

TC-FX120

SERVICE MANUAL

US Model
Canadian Model
AEP Model
UK Model
E Model

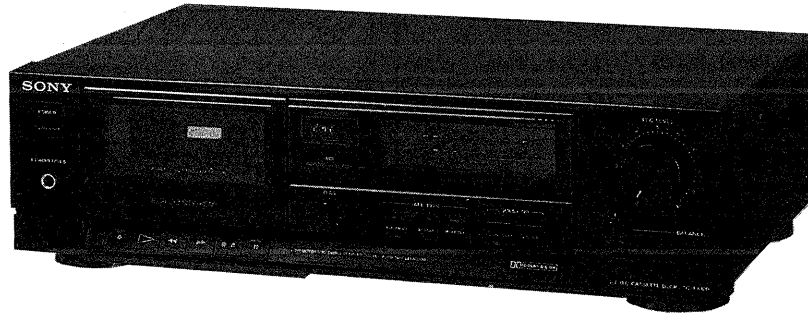

SPECIFICATIONS

Recording system 4-track 2-channel stereo
 Fast winding Approx. 120 sec. (with C-60 cassette)
 Bias AC Bias
 Signal-to-noise ratio (NAB, at peak level)

Cassette	Dolby NR switch		
	OFF	B-TYPE ON	C-TYPE ON
TYPE IV (Sony METAL-ES)	58 dB	65 dB	71 dB
TYPE II (Sony UX-S)	56 dB	63 dB	69 dB
TYPE I (Sony HF-S)	54 dB	61 dB	67 dB

Total harmonic distortion
 1.0% (with Sony METAL-ES cassettes)

Frequency response (DOLBY NR OFF)

TYPE IV cassette (Sony METAL-ES)	30–15,000 Hz (± 3 dB, DIN) 30–13,000 Hz (OVU recording)
TYPE II cassette (Sony UX-S)	30–14,000 Hz (± 3 dB, DIN)
TYPE I cassette (Sony HF-S)	30–13,000 Hz (± 3 dB, DIN)

Wow and flutter 0.12% WRMS (NAB)
 $\pm 0.2\%$ (DIN)

Inputs

Line inputs (phono jacks)	Sensitivity	77.5 mV (-20 dB)
	Input impedance	50k ohms

Outputs

Line outputs (phono jacks)	Rated output level	0.44 V (-5 dB) at a load impedance of 47k ohms
	Load impedance	Over 10k ohms
Headphone output (stereo phone jack)	Output level	0.3 mW at a load impedance of 32 ohms

Model Name Using Similar Mechanism	NEW
Tape Transport Mechanism Type	TCM-180VBN3

General

Power requirements

Model for the U.S.A. and Canada:
 120 V AC, 60 Hz

Model: for the AEP:
 220 V AC, 50/60Hz

Model for the United Kingdom:
 240 V AC, 50 Hz

Model for the E:
 110–220 V AC, 220–240 V
 AC, 50/60hz

Power consumption

14 W

Dimensions Approx. 430 × 123 × 286 mm (w/h/d)
 (17 × 4 $\frac{7}{8}$ × 11 $\frac{3}{8}$ inches)

including projecting parts and controls

Weight

Approx. 3.5 kg (7 lbs 12 oz)

Supplied accessory

Audio connecting cord (2)

Design and specifications subject to change without notice.

Note

This appliance conforms with EEC Directive 87/308/EEC regarding interference suppression.

Dolby noise reduction manufactured under license from Dolby Laboratories Licensing Corporation.

"DOLBY" and the double-D symbol  are trademarks of Dolby Laboratories Licensing Corporation.

STEREO CASSETTE DECK
SONY®

TABLE OF CONTENTS

<u>Section</u>	<u>Title</u>	<u>Page</u>
Specifications		1
Servicing Note		2
SECTION 1. GENERAL		
Identification of Front Panel Parts		3
SECTION 2. ADJUSTMENTS		
2-1. Mechanical Adjustments		4
2-2. Electrical Adjustments		4
SECTION 3. DIAGRAMS		
3-1. Block Diagram		6
3-2. Printed Wiring Boards		10
3-3. Schematic Diagram		13
SECTION 4. EXPLODED VIEWS		
SECTION 5. ELECTRICAL PARTS LIST		
		22

MODEL IDENTIFICATION

— Specification Label Printed on Back Panel —

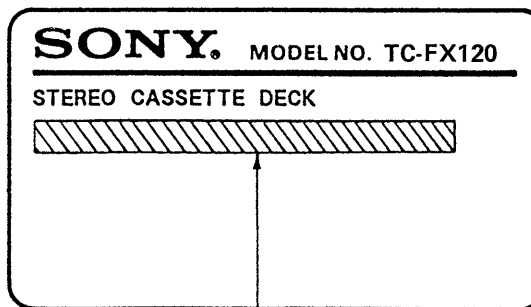

US/Canadian model: AC 120V 60Hz 12W

AEP model: AC 220V~50/60Hz

UK model: AC 240V~50/60Hz

E model: AC 110-120V, 220-240V~50/60Hz 13W

SAFETY CHECK-OUT

After correcting the original service problem, perform the following safety check before releasing the set to the customer:

Check the antenna terminals, metal trim, “metallized” knobs, screws, and all other exposed metal parts for AC leakage. Check leakage as described below.

LEAKAGE TEST

The AC leakage from any exposed metal part to earth ground and from all exposed metal parts to any exposed metal part having a return to chassis, must not exceed 0.5 mA (500 microamperes). Leakage current can be measured by any one of three methods.

1. A commercial leakage tester, such as the Simpson 229 or RCA WT-540A. Follow the manufacturers’ instructions to use these instruments.
2. A battery-operated AC milliammeter. The Data Precision 245 digital multimeter is suitable for this job.

3. Measuring the voltage drop across a resistor by means of a VOM or battery-operated AC voltmeter. The “limit” indication is 0.75 V, so analog meters must have an accurate low-voltage scale. The Simpson 250 and Sanwa SH-63Trd are examples of a passive VOM that is suitable. Nearly all battery operated digital multimeters that have a 2 V AC range are suitable. (See Fig. A)

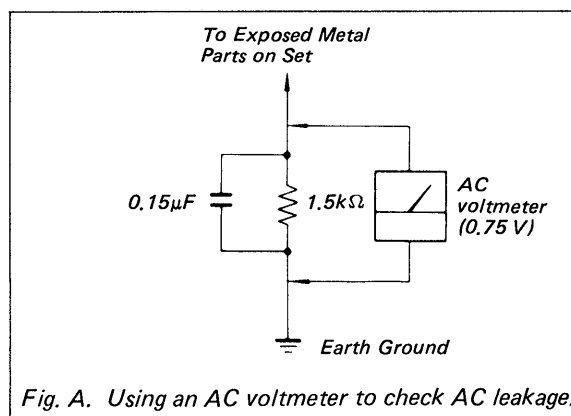

Fig. A. Using an AC voltmeter to check AC leakage.

SAFETY-RELATED COMPONENT WARNING!!

COMPONENTS IDENTIFIED BY MARK OR DOTTED LINE WITH MARK ON THE SCHEMATIC DIAGRAMS AND IN THE PARTS LIST ARE CRITICAL TO SAFE OPERATION. REPLACE THESE COMPONENTS WITH SONY PARTS WHOSE PART NUMBERS APPEAR AS SHOWN IN THIS MANUAL OR IN SUPPLEMENTS PUBLISHED BY SONY.

ATTENTION AU COMPOSANT AYANT RAPPORT À LA SÉCURITÉ!

LES COMPOSANTS IDENTIFIÉS PAR UNE MARQUE SUR LES DIAGRAMMES SCHÉMATIQUES ET LA LISTE DES PIÈCES SONT CRITIQUES POUR LA SÉCURITÉ DE FONCTIONNEMENT. NE REMPLACER CES COMPOSANTS QUE PAR DES PIÈCES SONY DONT LES NUMÉROS SONT DONNÉS DANS CE MANUEL OU DANS LES SUPPLÉMENTS PUBLIÉS PAR SONY.

SECTION 1 GENERAL

Identification of Front Panel Parts

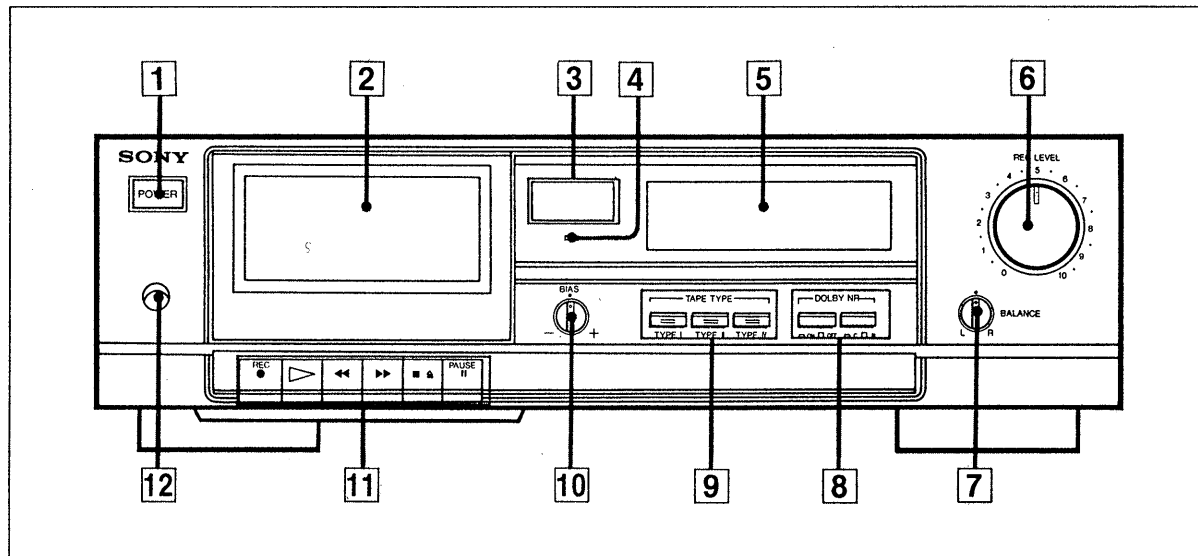

- | | |
|---|---|
| 1 POWER switch | 9 TAPE TYPE indicators |
| 2 Cassette holder | 10 BIAS control |
| 3 TAPE COUNTER and RESET button | 11 Tape operation buttons <ul style="list-style-type: none"> ● REC (record) button ▶ (play) button ◀◀ (rewind) button ▶▶ (fast-forward) button ■▲ (stop) and (eject) buttons PAUSE button |
| 4 RECORD INDICATOR | 12 HEADPHONES jack (stereo phone jack) |
| 5 PEAK LEVEL METER | |
| 6 REC (recording) LEVEL control | |
| 7 BALANCE control | |
| 8 DOLBY NR (Dolby Noise Reduction) buttons | |

SECTION 2 ADJUSTMENTS

2-1. MECHANICAL ADJUSTMENTS

PRECAUTION

1. Clean the following parts with a denatured-alcohol-moistened swab:

record/playback head	pinch roller
erase head	rubber belts
capstan	idler
2. Demagnetize the record/playback head with a head demagnetizer.
3. Do not use a magnetized screwdriver for the adjustments.
4. After the adjustments, apply suitable locking compound to the parts adjusted.
5. The adjustments should be performed with the rated power supply voltage unless otherwise noted.

Torque Measurement

Torque	Torque	Meter reading
FWD	CQ-102C	30 to 70 g·cm (0.43 to 0.97 oz·inch)
FWD Back tension	CQ-102C	1.5 to 5.5 g·cm (0.02 to 0.07 oz·inch)
FF, REW	CQ-201B	63 g·cm or more (0.87 oz·inch or more)

2-2. ELECTRICAL ADJUSTMENTS

Note: The adjustment should be performed in the order given in this service manual.
The adjustments should be performed for both L-CH and R-CH.

- Switches and controls should be set as follows unless otherwise specified.
DOLBY NR switch: OFF
- Standard Record:
Deliver the standard input signal level to the input jack and set the REC LEVEL control to obtain the standard output signal level.

— Record Mode —

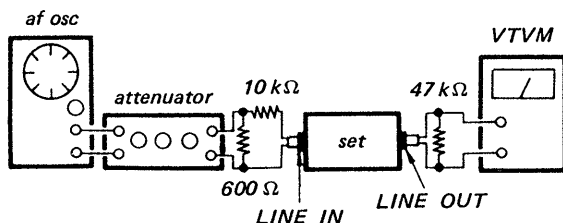

Standard Input Level

LINE IN	
source impedance	10 kΩ
input level	0.25 V (-10 dB)

Standard Output Level

LINE OUT	
load impedance	47 kΩ
output level	0.44 V (-5 dB)

Capstan Motor Speed Adjustment

Procedure:

Mode: playback

test tape
WS-48A
(3kHz, 0dB)

speed checker
LFM-30
or
digital frequency
counter

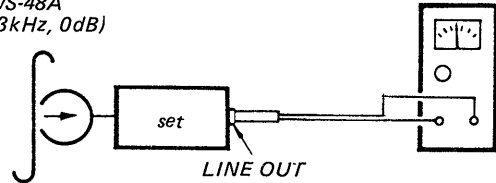

Specification:

Speed checker	Digital frequency counter
-0.3 ~ +0.3%	2,990 ~ 3,010Hz

Frequency difference between the beginning and the end of the tape should be within 0.3% (10 Hz).

Adjustment Location

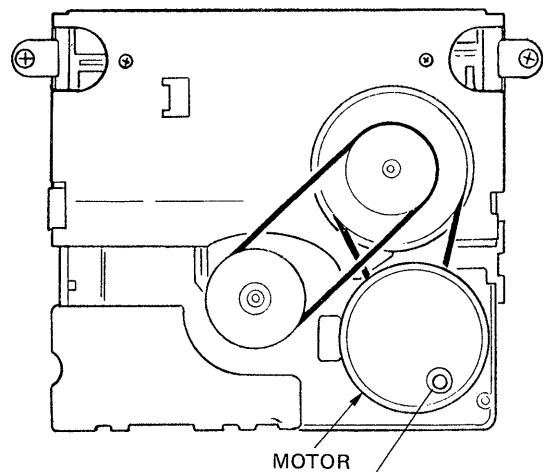

Adjust the speed by using screwdriver. When turning the screw clockwise, speed is faster.

Record/Playback Head Azimuth Adjustment

Procedure:

1. Mode: playback

test tape
P-4-A063
(6.3 kHz, -10 dB)

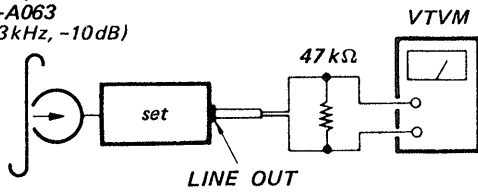

2. Turn the adjustment screw for the maximum output levels. If these levels do not match, turn the adjustment screw until both of output levels match together within 1 dB.

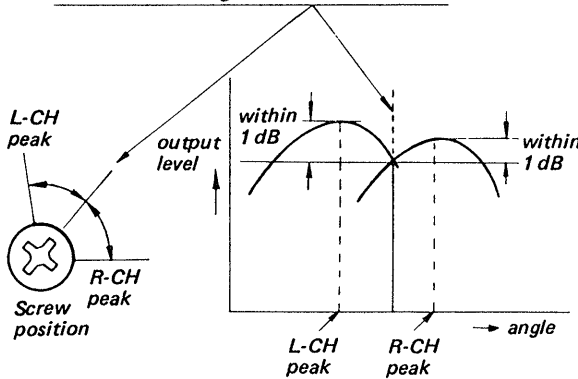

3. Phase Check

Mode: playback

test tape
P-4-063
(6.3 kHz, -10 dB)

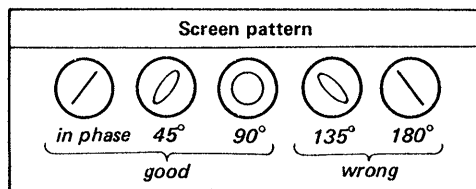
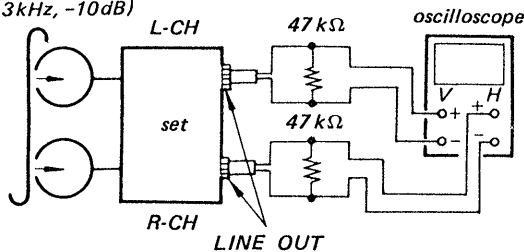

Adjustment Location:

— Record/Playback head —

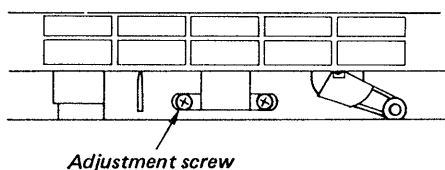

Playback Level Adjustment

Procedure:

1. Mode: playback

test tape
P-4-L300
(315 Hz, 0 dB)

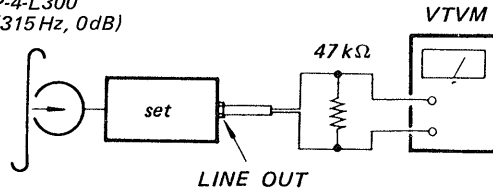

Adjust RV102 (L-CH) and RV202 (R-CH) so that the specification is met.

Specification:

Line OUT level: $-15 \text{ dB} \pm 0.5 \text{ dB}$

Level difference between channels:
less than 0.5 dB

Check that the LINE OUT level does not change in playback mode while changing the mode from playback to stop several times.

Record Bias Adjustment

Setting:

REC LEVEL control: standard record

Procedure:

1. Mode: record

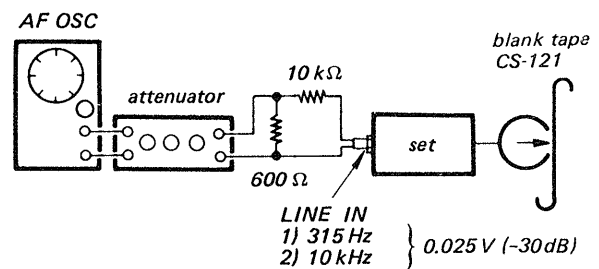

2. Mode: playback

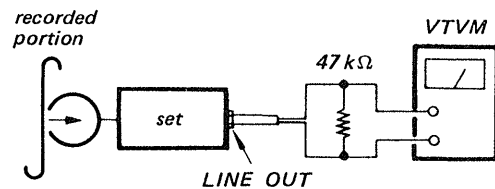

Confirm that the 10 kHz playback output is $0 \pm 0.5 \text{ dB}$ relative to the 315 Hz output. If necessary, adjust CT-301-1 (L-CH), CT301-2 (R-CH) and repeat the steps given above.

**SECTION 3
DIAGRAMS**

3-1. BLOCK DIAGRAM

Record Level Adjustment

Setting:
REC LEVEL control: standard record

Procedure:

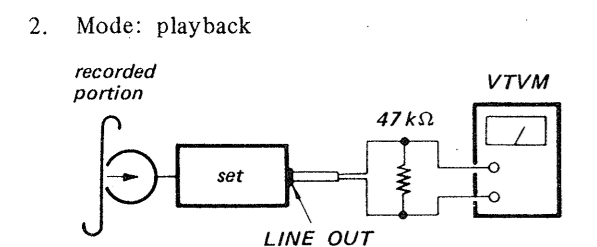
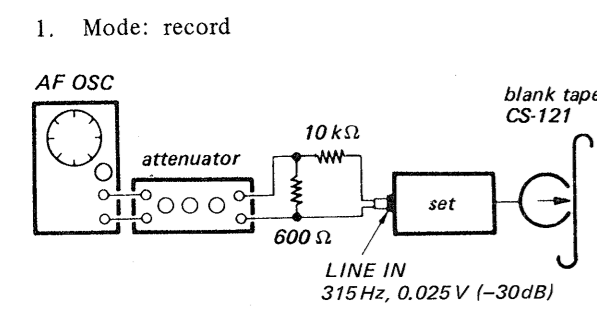

3. Playback the signal recorded in step 1.
Confirm that the signal level is within the specification below. If necessary, adjust RV101 (L-CH), RV201 (R-CH) and repeat the step 1-3.

Specification:
LINE OUT level: -25 dB ± 0.5 dB

Adjustment Location: audio board

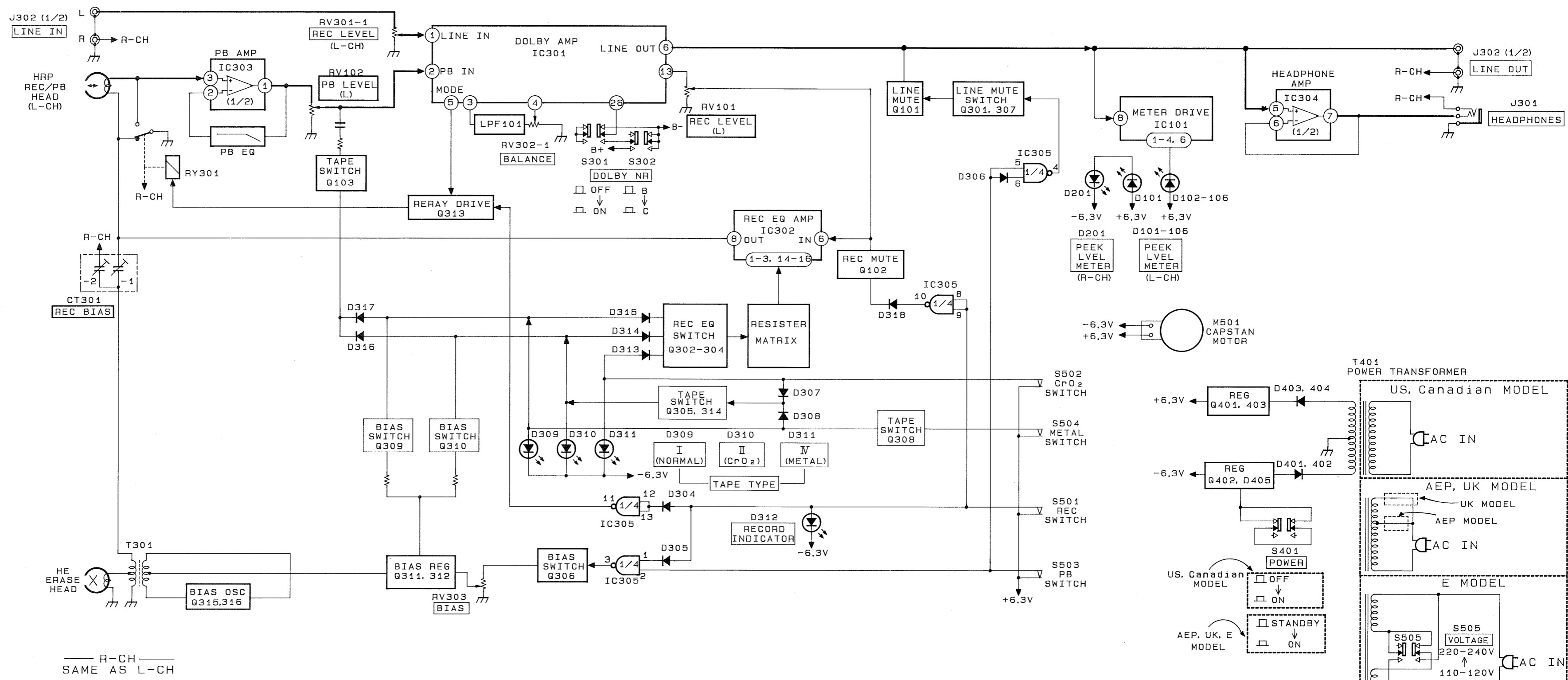
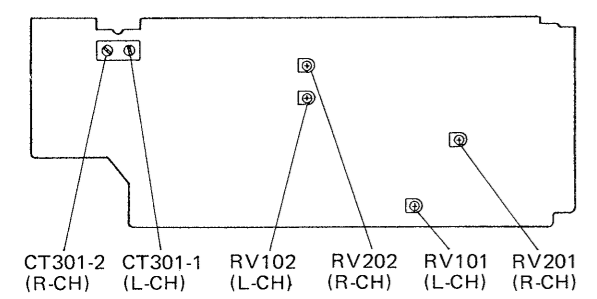

— R-CH —
— SAME AS L-CH —

• Semiconductor Lead Layouts

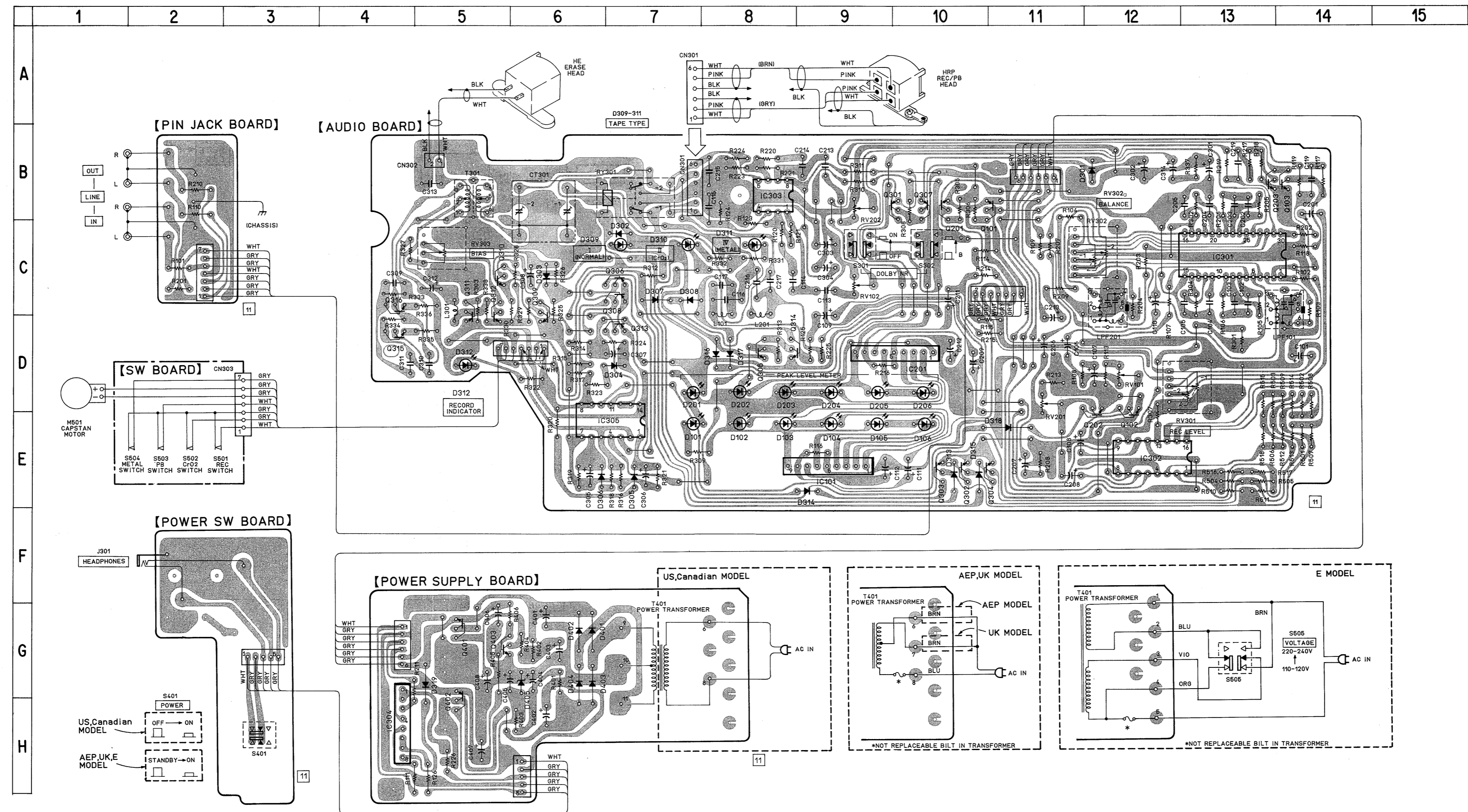
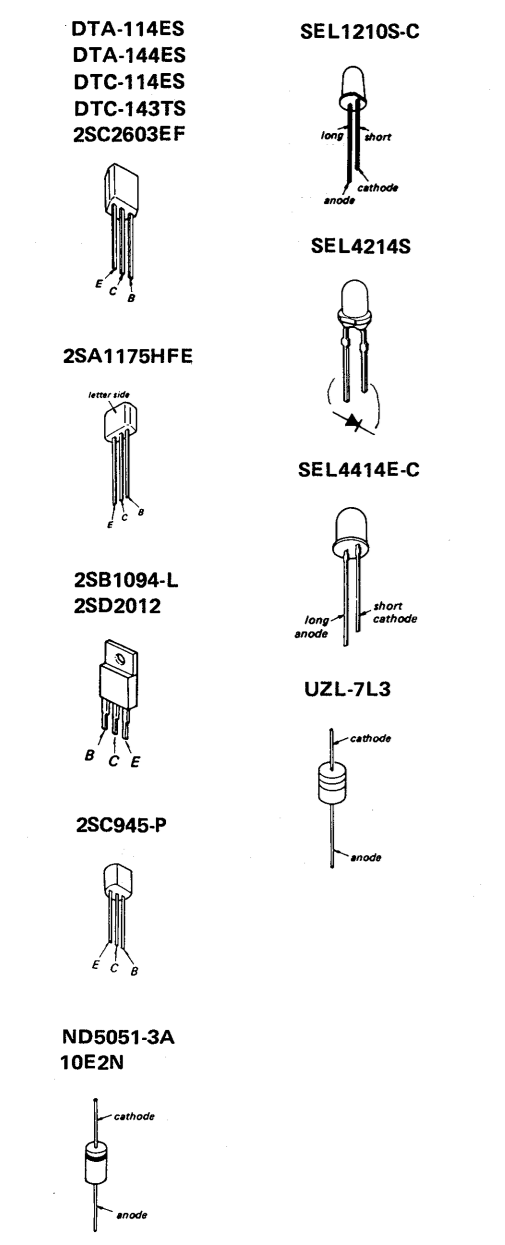

• Semiconductor Location

Ref. No.	Location	Ref. No.	Location
D101	E-7	D405	G-6
D102	E-8		
D103	E-8	IC101	E-9
D104	E-9	IC201	D-10
D105	E-9	IC301	C-13
D106	E-10	IC302	F-12
D201	D-7	IC303	B-8
D202	D-8	IC304	H-4
D203	D-8	IC305	E-7
D204	D-9		
D205	D-9	0101	C-11
D206	D-10	0102	E-12
D301	B-12	0103	B-14
D302	C-7	0201	B-10
D303	C-6	0202	E-12
D304	D-7	0203	B-13
D305	E-7	0301	B-10
D306	E-6	0302	E-10
D307	C-7	0303	E-10
D308	C-7	0304	D-7
D309	C-7	0305	D-8
D310	C-7	0306	C-7
D311	C-8	0307	B-10
D312	D-5	0308	C-7
D313	E-10	0309	C-6
D314	E-9	0310	C-5
D315	E-10	0311	C-5
D316	D-8	0312	C-5
D317	D-8	0313	D-7
D318	E-11	0314	D-8
D319	G-5	0315	D-4
D401	G-6	0316	D-4
D402	G-6	0401	G-5
D403	G-6	0402	H-5
D404	G-6	0403	G-5

Note:
 • ○ : parts extracted from the component side.
 • □ : indicates side identified with part number.

3-3. SCHEMATIC DIAGRAM

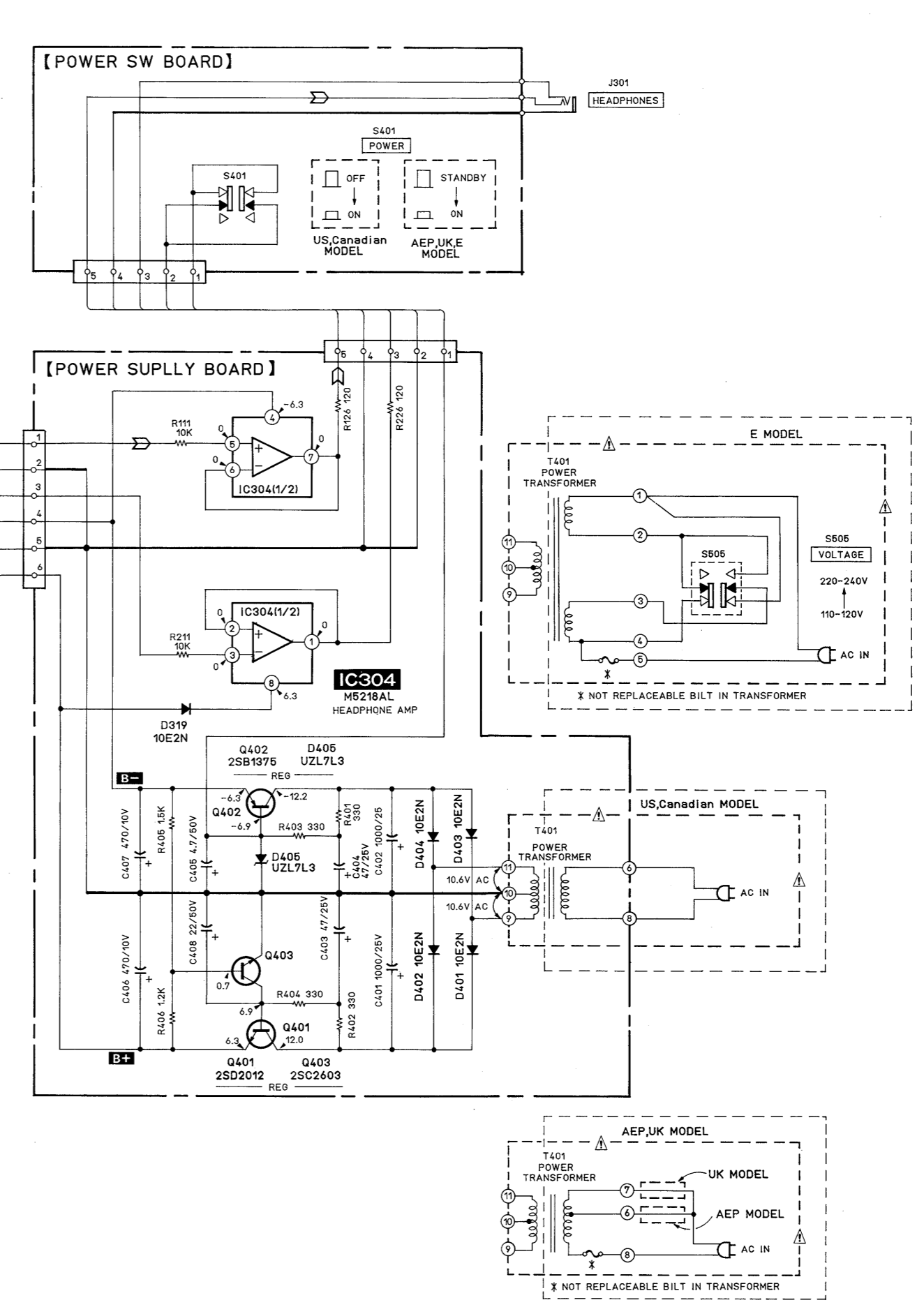
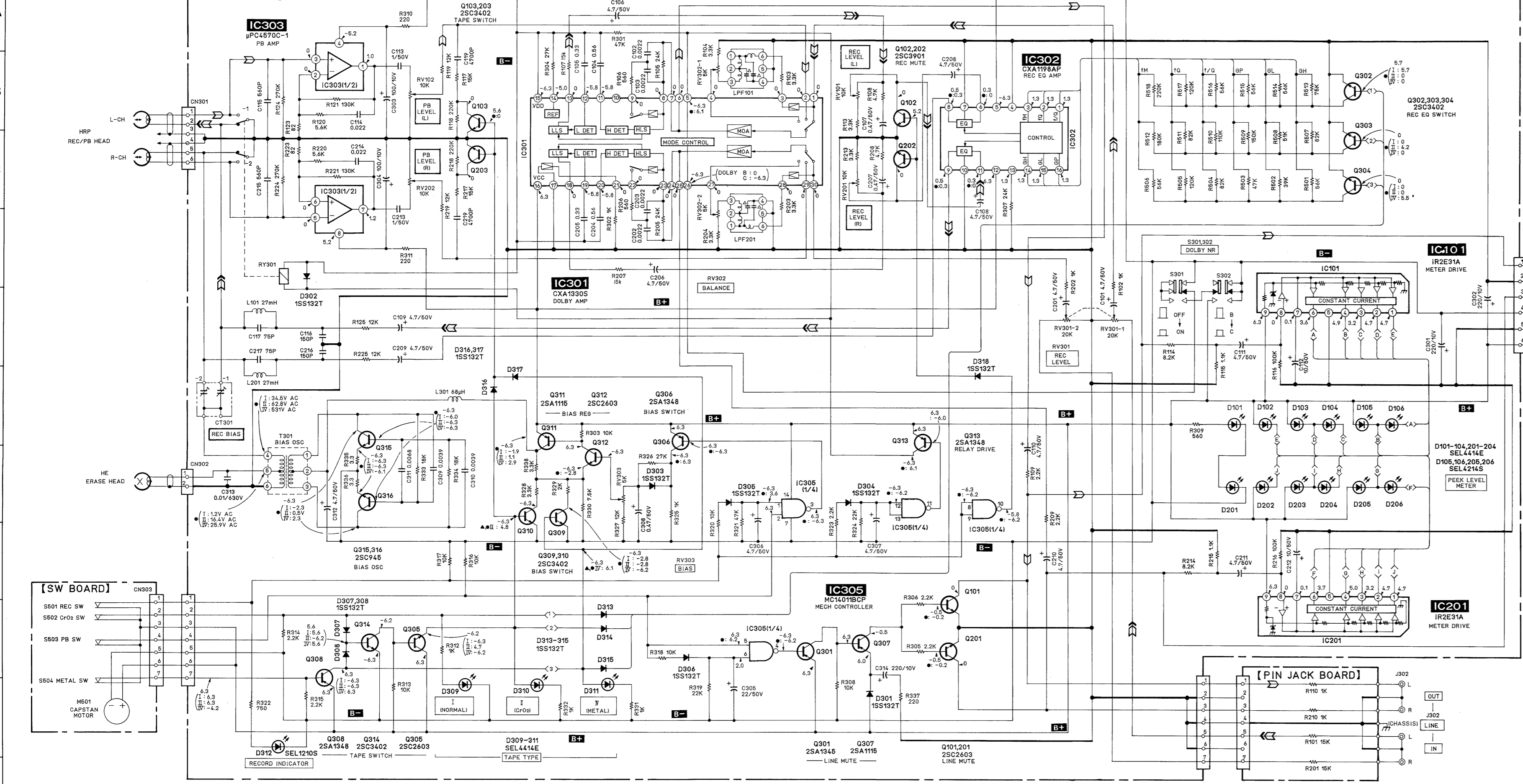

- Note:**
- All capacitors are in μF unless otherwise noted. pF : μF 50WV or less are not indicated except for electrolytics and tantalums.
 - All resistors are in Ω and $1/4\text{W}$ or less unless otherwise specified.
 - Δ : internal component.
 - B+**: B+ Line
 - B-**: B- Line
 - \square : adjustment for repair.
 - AC voltage readings in the bias oscillator with a VTVM.
 - Voltages are taken with a VOM. (Input impedance 10M Ω)
 - Voltage variations may be noted due to normal production tolerances.
 - no mark: PLAY
 - : REC
 - Signal path.
 - \Rightarrow : PB
 - \Rightarrow : REC

Note: The components identified by shading and mark Δ are critical for safety. Replace only with part number specified.

Note: Les composants identifiés par une trame et une marque Δ sont critiques pour la sécurité. Ne les remplacer que par une pièce portant le numéro spécifié.

SECTION 5 EXPLODED VIEWS

NOTE:

- The mechanical parts with no reference number in the exploded views are not supplied.
- The construction parts of an assembled part are indicated with a collation number in the remark column.
- Items marked "★" are not stocked since they are seldom required for routine service. Some delay should be anticipated when ordering these items.

- Due to standardization, parts with part number suffix -XX and -X may be different from the parts specified in the components used on the set.

- Color Indication of Appearance Parts
Example:

(RED) ... KNOB, BALANCE (WHITE)

↑
Cabinet's Color

↑
Parts' Color

The components identified by mark or dotted line with mark are critical for safety. Replace only with part number specified.

Les composants identifiés par une marque sont critiques pour la sécurité. Ne les remplacer que par une pièce portant le numéro spécifié.

(1) CABINET AND FRONT PANEL SECTION

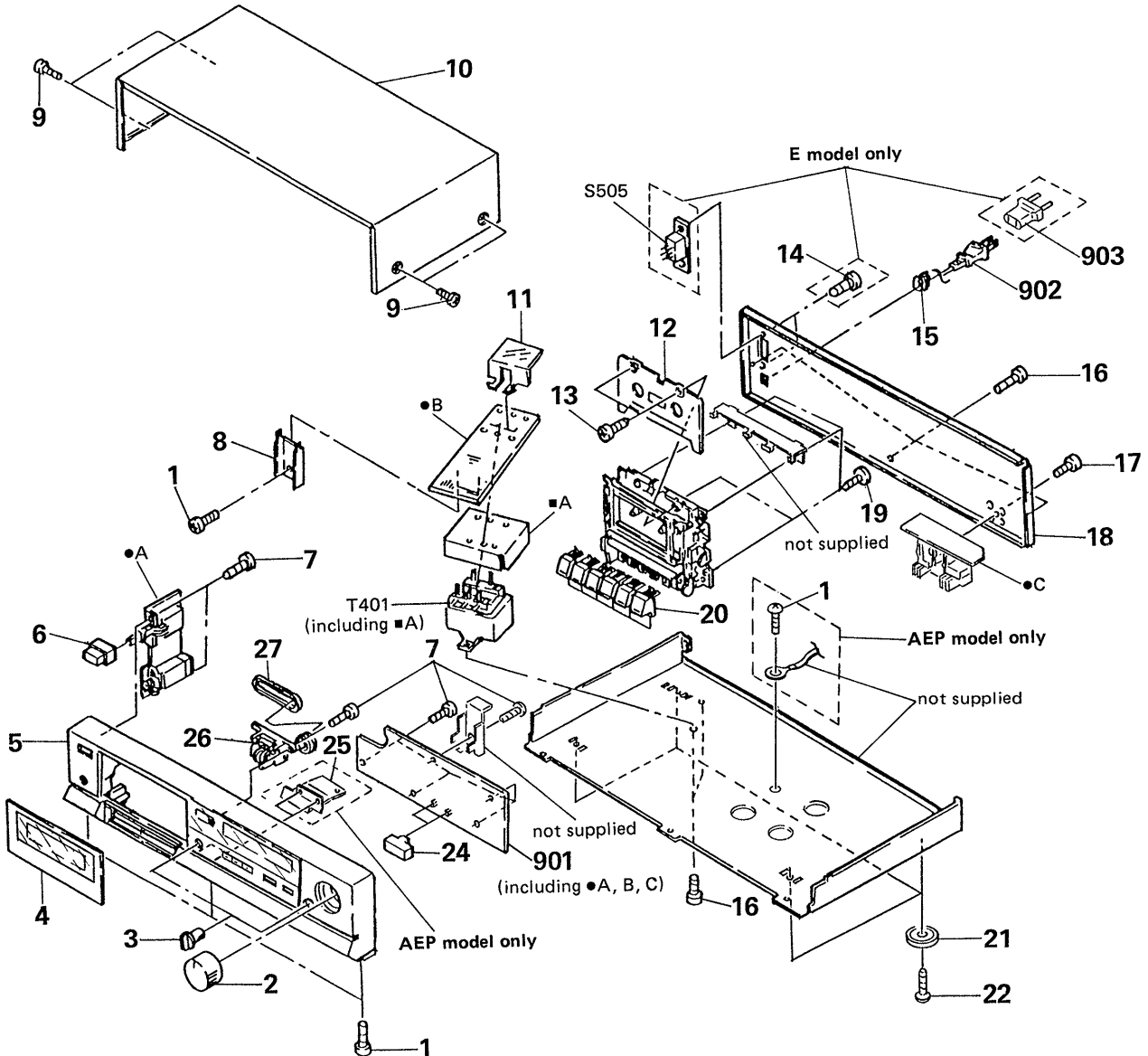

No.	Part No.	Description	Remarks
1	7-682-547-04	SCREW +BVTT 3X6 (S)	
2	3-327-846-01	KNOB	
3	3-346-380-01	KNOB (VOL)	
4	X-3318-963-1	LID ASSY, CASSETTE	
5	X-3318-964-1	(AEP,UK,E)...PANEL ASSY, FRONT	
	X-3318-965-1	(US,Canadian).PANEL ASSY, FRONT	
6	3-354-912-01	KNOB, POWER	
7	4-928-635-01	SCREW, +BV (2.6X8) TAPPING	
8	*3-309-144-21	HEAT SINK	
9	3-704-366-01	SCREW (CASE) (M3X8)	
10	3-332-578-42	CASE	
11	*3-327-872-01	COVER (TRANSFORMER)	
12	X-3358-214-1	PLATE ASSY, ORNAMENTAL	
13	7-685-133-19	SCREW +BTP 2.6X6 TYPE2 N-S	
14	7-685-534-19	(E)..... SCREW +BTP 2.6X8 TYPE2 V-S	
15	*3-703-244-00	(AEP,UK).....BUSHING (2104), CORD	
	*3-703-571-12	(US,Canadian,E)... BUSHING (S)(4516), CORD	
16	7-682-547-09	SCREW +BVTT 3X6 (S)	
17	7-621-849-00	SCREW, TAPPING	
18	*3-327-877-71	(AEP).....PANEL, BACK	
	*3-327-877-51	(US,Canadian).PANEL, BACK	
	*3-327-877-81	(E).....PANEL, BACK	
	*3-327-877-91	(UK).....PANEL, BACK	
19	4-928-635-21	SCREW, +BV (2.6X10) TAPPING	
20	3-349-043-11	BUTTON (BLOCK B)	
21	X-3304-938-2	(AEP,UK).....FOOT ASSY	
	X-4885-950-2	(US,Canadian,E)..FOOT ASSY	
22	7-682-548-04	SCREW +BVTT 3X8 (S)	
24	3-350-810-01	BUTTON	
25	*3-327-882-11	PLATE, SHIELD	
26	1-548-596-61	COUNTER, TAPE (MIDDLE TYPE)	
27	3-527-150-XX	BELT, CAPSTAN	
901	*A-2006-243-A	MOUNTED PCB, AUDIO	
902	△.1-555-795-00	(AEP).....CORD, POWER, EULO PLUG	
	△.1-551-884-32	(UK).....CORD, POWER	
	△.1-551-506-XX	(US,Canadian).CORD, POWER	
	△.1-551-188-XX	(E).....CORD, POWER	
903	△.1-526-565-00	(E).....AC PLUG ADAPTOR	
S505	△.1-552-535-00	(E)..SWITCH POWER & VOLTAGE CHANGE	
T401	△.1-449-390-11	(AEP,UK).....TRANSFORMER, POWER	
	△.1-449-593-11	(US,Canadian)...TRANSFORMER, POWER	
	△.1-449-388-11	(E).....TRANSFORMER, POWER	

Note:

The components identified by mark △ or dotted line with mark △ are critical for safety. Replace only with part number specified.

Note:

Les composants identifiés par une marque △ sont critiques pour la sécurité. Ne les remplacer que par une pièce portant le numéro spécifié.

(2) MECHANISM SECTION-1
(TCM-180VB-N3)

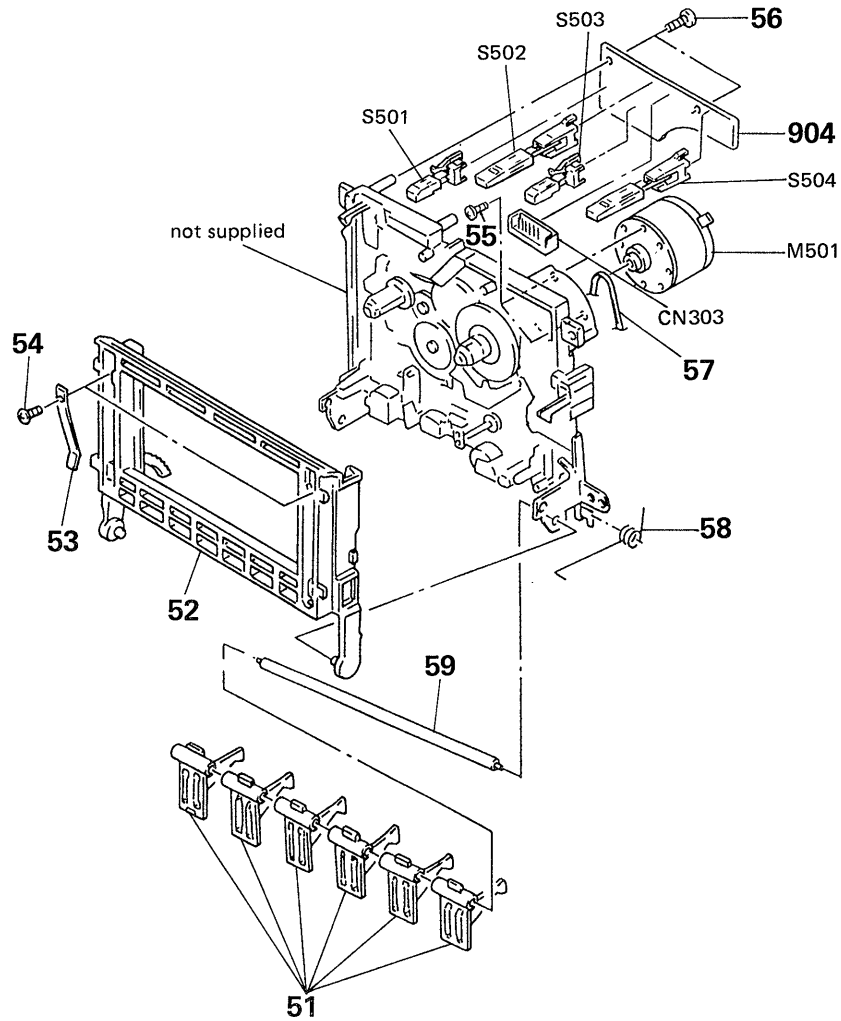

<u>No.</u>	<u>Part No.</u>	<u>Description</u>	<u>Remarks</u>	<u>No.</u>	<u>Part No.</u>	<u>Description</u>	<u>Remarks</u>
51	3-358-271-01	LEVER (BUTTON BASE A)		904	1-635-160-11	SW BOARD	
52	3-358-266-01	HOLDER, CASSETTE		CN303*1-564-500-11		PIN, CONNECTOR 7P	
53	3-358-209-01	SPRING (CASSETTE HOLDER), LEAF		M501	X-3358-211-1	MOTOR (A) ASSY	
54	7-685-103-19	SCREW +P 2X5 TYPE2 NON-SLIT		S501	1-571-736-11	SWITCH, LEAF	
55	7-621-775-20	SCREW +B 2.6X5		S502	*1-572-335-11	SWITCH, LEAF	
56	7-685-133-19	SCREW +BTP 2.6X6 TYPE2 N-S		S503	1-571-736-11	SWITCH, LEAF	
57	3-358-230-01	BELT (A1)		S504	*1-572-335-11	SWITCH, LEAF	
58	3-358-229-01	SPRING (LOADING), TORSION					
59	3-358-242-01	SHAFT (BUTTON SHAFT)					

(3) MECHANISM SECTION-2
(TCM-180VB-N3)

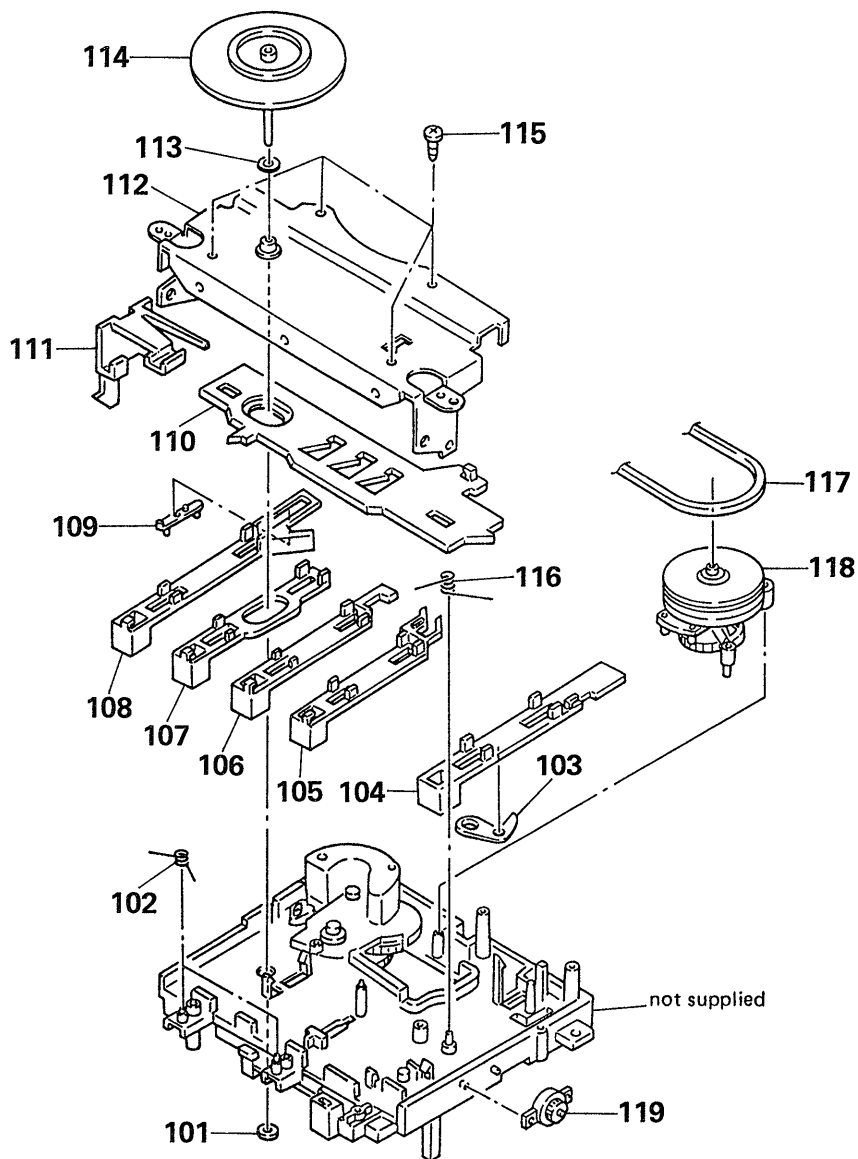

No.	Part No.	Description	Remarks	No.	Part No.	Description	Remarks
101	7-623-921-01	WASHER 1.7, NYLONE		111	*3-358-261-01	SLIDER (HOLDER LOCK)	
102	3-358-232-01	SPRING (S-P F-R), TORSION		112	*X-3358-213-1	BRACKET (A) ASSY	
103	*3-358-204-01	LEVER (REC SAFETY)		113	3-701-437-01	WASHER	
104	3-358-259-01	SLIDER (REC)		114	X-3358-205-1	FLYWHEEL (A) ASSY	
105	3-358-258-01	SLIDER (REW)		115	7-685-133-19	SCREW +P 2.6X6 TYPE1	
106	3-358-257-01	SLIDER (FF)		116	3-358-233-01	SPRING (REC-LOCK) TORSION	
107	3-358-256-01	SLIDER (STOP/EJECT)		117	3-358-230-01	BELT (A1)	
108	3-358-260-01	SLIDER (PAUSE)		118	X-3358-202-1	LEVER (FR ARM) ASSY	
109	*3-358-226-01	LEVER (PAUSE LEVER)		119	3-319-224-31	DAMPER, SMALL	
110	*3-358-249-01	SLIDER (LOCK PLATE)					

(4) MECHANISM SECTION-3
(TCM-180VB-N3)

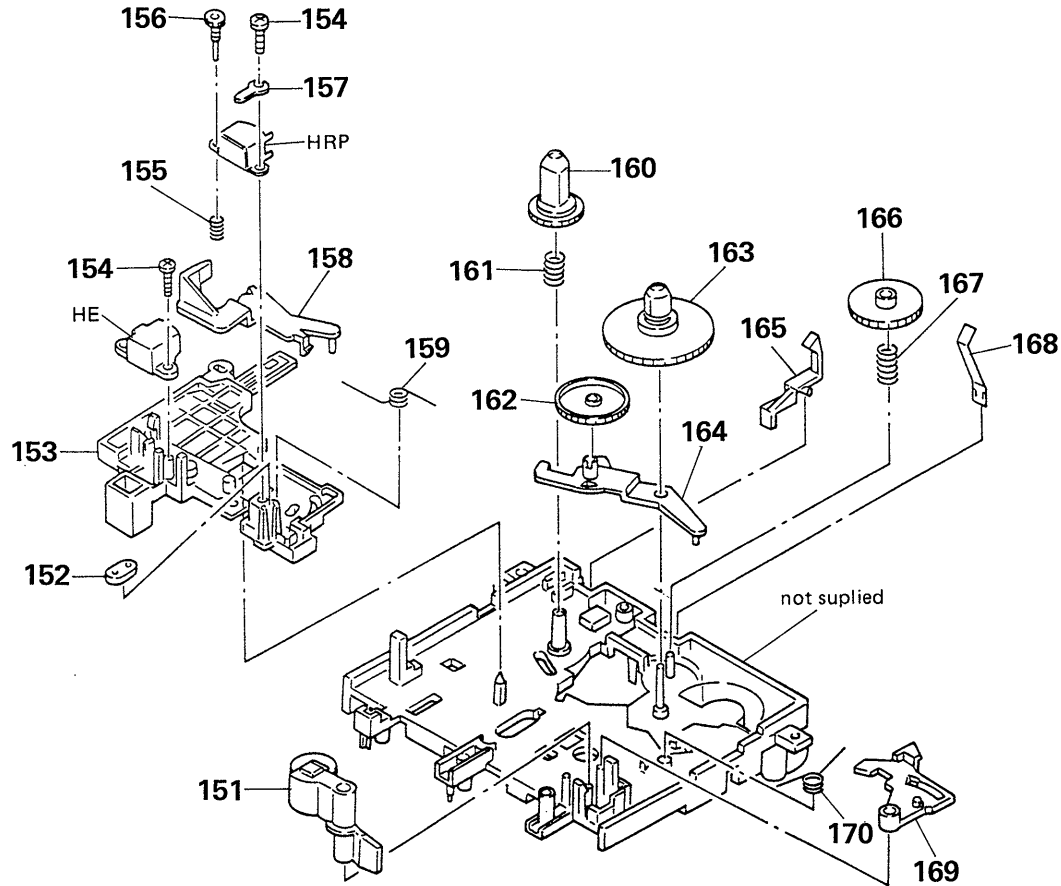

No.	Part No.	Description	Remarks	No.	Part No.	Description	Remarks
151	X-3358-204-1	LEVER (PINCH LEVER) ASSY		163	X-3358-203-1	TABLE (T) ASSY, REEL	
152	*3-358-215-01	BUSHING (WIRE KIT RETAINER)		164	*3-358-252-01	LEVER (TU ARM)	
153	3-358-265-01	SLIDER (HEAD PC BOARD A)		165	*3-358-255-01	LEVER (GB LEVER)	
154	7-685-105-19	TPG +P 2X8, TYPE 2, NON-SLIT		166	*3-358-224-01	GEAR (FF GEAR)	
155	3-358-234-01	SPRING (AZIMUTH), COMPRESSION		167	3-358-207-01	SPRING (FF GEAR), COMPRESSION	
156	3-358-213-01	SCREW, AZIMUTH		168	3-358-227-01	SPRING, LEAF	
157	7-623-505-01	LUG, 2		169	*3-358-253-01	LEVER (SHUT-OFF LEVER)	
158	*3-358-251-01	LEVER (TENSION DETECTION ARM)		170	3-358-243-01	SPRING (TU-SHUT), TORSION	
159	3-358-228-01	SPRING, TORSION					
160	3-358-248-01	GEAR (SUPPLY REEL)		HE	1-543-673-11	HEAD, MAGNETIC (ERASE)	
161	3-358-208-01	SPRING (SUPPLY), COMPRESSION		HRP	1-543-672-11	HEAD, MAGNETIC (REC/PB)	
162	*3-358-225-01	GEAR (TU GEAR)					

SECTION 6 ELECTRICAL PARTS LIST

NOTE:

- Due to standardization, replacements in the parts list may be different from the parts specified in the diagrams or the components used on the set.
- Items marked "★" are not stocked since they are seldom required for routine service. Some delay should be anticipated when ordering these items.
- If there are two or more same circuits in a set such as a stereophonic machine, only typical circuit parts may be indicated and capacitors and resistors in other same circuits may be omitted.

CAPACITORS:
MF: μ F, PF: μ μ F.

RESISTORS
• All resistors are in ohms.
• F: nonflammable

COILS
• MMH: mH, UH: μ H

SEMICONDUCTORS
In each case, U: μ , for example:
UA...: μ A..., UPA...: μ PA...,
UPC...: μ PC, UPD...: μ PD...

The components identified by mark Δ or dotted line with mark Δ are critical for safety. Replace only with part number specified.

Les composants identifiés par une marque Δ sont critiques pour la sécurité. Ne les remplacer que par une pièce portant le numéro spécifié.

Ref.No.	Part No.	Description				
901	*A-2006-243-A	MOUNTED PCB, AUDIO				
902	Δ .1-555-795-00 Δ .1-551-884-32 Δ .1-551-506-XX Δ .1-551-188-XX	CORD, POWER, EULO PLUG (UK).....CORD, POWER (US,Canadian).CORD, POWER (E).....CORD, POWER				
903	Δ .1-526-565-00	(E).....AC PLUG ADAPTOR				
904	1-635-160-11	SW BOARD				
C101	1-124-927-11	ELECT	4.7MF	20%	50V	
C102	1-130-475-00	MYLAR	0.0022MF	5%	50V	
C103	1-130-475-00	MYLAR	0.0022MF	5%	50V	
C104	1-136-174-00	FILM	0.56MF	5%	50V	
C105	1-136-840-11	FILM	0.33MF	5%	50V	
C106	1-124-927-11	ELECT	4.7MF	20%	50V	
C107	1-124-902-00	ELECT	0.47MF	20%	50V	
C108	1-124-927-11	ELECT	4.7MF	20%	50V	
C109	1-124-927-11	ELECT	4.7MF	20%	50V	
C110	1-124-927-11	ELECT	4.7MF	20%	50V	
C111	1-124-927-11	ELECT	4.7MF	20%	50V	
C112	1-123-875-11	ELECT	10MF	20%	50V	
C113	1-124-611-00	ELECT	1MF	20%	50V	
C114	1-136-157-00	FILM	0.022MF	5%	50V	
C115	1-162-291-31	CERAMIC	560PF	10%	50V	
C116	1-162-284-31	CERAMIC	150PF	10%	50V	
C117	1-136-273-91	FILM	75PF	5%	630V	
C119	1-161-377-00	CERAMIC	0.0047MF	30%	16V	
C201	1-124-927-11	ELECT	4.7MF	20%	50V	
C202	1-130-475-00	MYLAR	0.0022MF	5%	50V	
C203	1-130-475-00	MYLAR	0.0022MF	5%	50V	
C204	1-136-174-00	FILM	0.56MF	5%	50V	
C205	1-136-840-11	FILM	0.33MF	5%	50V	
C206	1-124-927-11	ELECT	4.7MF	20%	50V	
C207	1-124-902-00	ELECT	0.47MF	20%	50V	
C208	1-124-927-11	ELECT	4.7MF	20%	50V	
C209	1-124-927-11	ELECT	4.7MF	20%	50V	
C210	1-124-927-11	ELECT	4.7MF	20%	50V	
C211	1-124-927-11	ELECT	4.7MF	20%	50V	
C212	1-123-875-11	ELECT	10MF	20%	50V	
C213	1-124-611-00	ELECT	1MF	20%	50V	
C214	1-136-157-00	FILM	0.022MF	5%	50V	
C215	1-162-291-31	CERAMIC	560PF	10%	50V	
C216	1-162-284-31	CERAMIC	150PF	10%	50V	
C217	1-136-273-91	FILM	75PF	5%	630V	
C219	1-161-377-00	CERAMIC	0.0047MF	30%	16V	

Ref.No.	Part No.	Description				
C301	1-126-176-11	ELECT	220MF	20%	10V	
C302	1-126-176-11	ELECT	220MF	20%	10V	
C303	1-124-443-00	ELECT	100MF	20%	10V	
C304	1-124-443-00	ELECT	100MF	20%	10V	
C305	1-126-233-11	ELECT	22MF	20%	50V	
C306	1-124-927-11	ELECT	4.7MF	20%	50V	
C307	1-124-927-11	ELECT	4.7MF	20%	50V	
C308	1-124-902-00	ELECT	0.47MF	20%	50V	
C309	1-130-478-00	MYLAR	0.0039MF	5%	50V	
C310	1-130-478-00	MYLAR	0.0039MF	5%	50V	
C311	1-130-481-00	MYLAR	0.0068MF	5%	50V	
C312	1-124-927-11	ELECT	4.7MF	20%	50V	
C313	1-136-601-11	FILM	0.01MF	5%	630V	
C314	1-126-176-11	ELECT	220MF	20%	10V	
C401	1-124-557-11	ELECT	1000MF	20%	25V	
C402	1-124-557-11	ELECT	1000MF	20%	25V	
C403	1-124-477-11	ELECT	47MF	20%	25V	
C404	1-124-477-11	ELECT	47MF	20%	25V	
C405	1-124-927-11	ELECT	4.7MF	20%	50V	
C406	1-124-472-11	ELECT	470MF	20%	10V	
C407	1-124-472-11	ELECT	470MF	20%	10V	
C408	1-126-233-11	ELECT	22MF	20%	50V	
CN301	*1-564-509-11	PLUG, CONNECTOR 6P				
CN302	*1-564-505-11	PLUG, CONNECTOR 2P				
CN303	*1-564-500-11	PIN, CONNECTOR 7P				
CT301	1-141-225-00	CAP, TUNING, TRIMAR (REC BIAS)				
D101	8-719-304-37	DIODE SEL4414E-C				
D102	8-719-304-37	DIODE SEL4414E-C				
D103	8-719-304-37	DIODE SEL4414E-C				
D104	8-719-304-37	DIODE SEL4414E-C				
D105	8-719-304-32	DIODE SEL4214S				
D106	8-719-304-32	DIODE SEL4214S				
D201	8-719-304-37	DIODE SEL4414E-C				
D202	8-719-304-37	DIODE SEL4414E-C				
D203	8-719-304-37	DIODE SEL4414E-C				
D204	8-719-304-37	DIODE SEL4414E-C				
D205	8-719-304-32	DIODE SEL4214S				
D206	8-719-304-32	DIODE SEL4214S				
D301	8-719-119-40	DIODE ND5051-3A				
D302	8-719-119-40	DIODE ND5051-3A				
D303	8-719-119-40	DIODE ND5051-3A				
D304	8-719-119-40	DIODE ND5051-3A				
D305	8-719-119-40	DIODE ND5051-3A				
D306	8-719-119-40	DIODE ND5051-3A				

Ref.No.	Part No.	Description
D307	8-719-119-40	DIODE ND5051-3A
D308	8-719-119-40	DIODE ND5051-3A
D309	8-719-304-37	DIODE SEL4414E-C
D310	8-719-304-37	DIODE SEL4414E-C
D311	8-719-304-37	DIODE SEL4414E-C
D312	8-719-302-46	DIODE SEL1210S-C
D313	8-719-119-40	DIODE ND5051-3A
D314	8-719-119-40	DIODE ND5051-3A
D315	8-719-119-40	DIODE ND5051-3A
D316	8-719-119-40	DIODE ND5051-3A
D317	8-719-119-40	DIODE ND5051-3A
D318	8-719-119-40	DIODE ND5051-3A
D319	8-719-200-77	DIODE 10E2N
D401	8-719-200-77	DIODE 10E2N
D402	8-719-200-77	DIODE 10E2N
D403	8-719-200-77	DIODE 10E2N
D404	8-719-200-77	DIODE 10E2N
D405	8-719-000-81	DIODE UZL-7L3
HE	1-543-673-11	HEAD, MAGNETIC (ERASE)
HRP	1-543-672-11	HEAD, MAGNETIC (REC/PB)
IC101	8-759-917-42	IC IR2E31A
IC201	8-759-917-42	IC IR2E31A
IC301	8-752-036-34	IC CXA1330S
IC302	8-752-038-02	IC CXA1198AP
IC303	8-759-111-44	IC UPC4570C-1
IC304	8-759-634-50	IC M5218AL
IC305	8-759-140-11	IC UPD4011BC
J301	1-507-981-11	JACK (LARGE TYPE) (HEADPHONES)
J302	1-565-259-11	JACK, PIN 4P (LINE IN/OUT)
L101	1-410-780-11	INDUCTOR 27MMH
L201	1-410-780-11	INDUCTOR 27MMH
L301	1-410-976-11	INDUCTOR 68UH
LPF101	1-236-087-11	FILTER, LOW PASS
LPF201	1-236-087-11	FILTER, LOW PASS
M501	X-3358-211-1	MOTOR (A) ASSY
Q101	8-729-620-05	TRANSISTOR 2SC2603-EF
Q102	8-729-900-74	TRANSISTOR DTC143TS
Q103	8-729-900-80	TRANSISTOR DTC114ES
Q201	8-729-620-05	TRANSISTOR 2SC2603-EF
Q202	8-729-900-74	TRANSISTOR DTC143TS
Q203	8-729-900-80	TRANSISTOR DTC114ES
Q301	8-729-900-65	TRANSISTOR DTA144ES
Q302	8-729-900-80	TRANSISTOR DTC114ES
Q303	8-729-900-80	TRANSISTOR DTC114ES
Q304	8-729-900-80	TRANSISTOR DTC114ES
Q305	8-729-620-05	TRANSISTOR 2SC2603-EF
Q306	8-729-900-61	TRANSISTOR DTA114ES
Q307	8-729-119-76	TRANSISTOR 2SA1175-HFE
Q308	8-729-900-61	TRANSISTOR DTA114ES
Q309	8-729-900-80	TRANSISTOR DTC114ES
Q310	8-729-900-80	TRANSISTOR DTC114ES
Q311	8-729-119-76	TRANSISTOR 2SA1175-HFE
Q312	8-729-620-05	TRANSISTOR 2SC2603-EF
Q313	8-729-900-61	TRANSISTOR DTA114ES
Q314	8-729-900-80	TRANSISTOR DTC114ES
Q315	8-729-194-57	TRANSISTOR 2SC945-P



Ref.No.	Part No.	Description			
Q316	8-729-194-57	TRANSISTOR 2SC945-P			
Q401	8-729-209-15	TRANSISTOR 2SD2012			
Q402	8-729-111-67	TRANSISTOR 2SB1094-L			
Q403	8-729-620-05	TRANSISTOR 2SC2603-EF			
R101	1-249-431-11	CARBON	15K	5%	1/4W
R102	1-249-417-11	CARBON	1K	5%	1/4W
R103	1-249-423-11	CARBON	3.3K	5%	1/4W
R104	1-249-423-11	CARBON	3.3K	5%	1/4W
R105	1-247-864-11	CARBON	24K	5%	1/4W
R106	1-249-414-11	CARBON	560	5%	1/4W
R107	1-249-432-11	CARBON	18K	5%	1/4W
R108	1-249-425-11	CARBON	4.7K	5%	1/4W
R109	1-249-421-11	CARBON	2.2K	5%	1/4W
R110	1-249-417-11	CARBON	1K	5%	1/4W
R111	1-249-429-11	CARBON	10K	5%	1/4W
R113	1-249-423-11	CARBON	3.3K	5%	1/4W
R114	1-249-428-11	CARBON	8.2K	5%	1/4W
R115	1-247-832-11	CARBON	1.1K	5%	1/4W
R116	1-249-441-11	CARBON	100K	5%	1/4W
R117	1-249-431-11	CARBON	15K	5%	1/4W
R118	1-247-887-00	CARBON	220K	5%	1/4W
R119	1-249-430-11	CARBON	12K	5%	1/4W
R120	1-249-426-11	CARBON	5.6K	5%	1/4W
R121	1-247-882-11	CARBON	130K	5%	1/4W
R123	1-249-404-00	CARBON	82	5%	1/4W
R124	1-247-889-00	CARBON	270K	5%	1/4W
R125	1-249-430-11	CARBON	12K	5%	1/4W
R126	1-249-406-11	CARBON	120	5%	1/4W
R201	1-249-431-11	CARBON	15K	5%	1/4W
R202	1-249-417-11	CARBON	1K	5%	1/4W
R203	1-249-423-11	CARBON	3.3K	5%	1/4W
R204	1-249-423-11	CARBON	3.3K	5%	1/4W
R205	1-247-864-11	CARBON	24K	5%	1/4W
R206	1-249-414-11	CARBON	560	5%	1/4W
R207	1-249-432-11	CARBON	18K	5%	1/4W
R208	1-249-425-11	CARBON	4.7K	5%	1/4W
R209	1-249-421-11	CARBON	2.2K	5%	1/4W
R210	1-249-417-11	CARBON	1K	5%	1/4W
R211	1-249-429-11	CARBON	10K	5%	1/4W
R213	1-249-423-11	CARBON	3.3K	5%	1/4W
R214	1-249-428-11	CARBON	8.2K	5%	1/4W
R215	1-247-832-11	CARBON	1.1K	5%	1/4W
R216	1-249-441-11	CARBON	100K	5%	1/4W
R217	1-249-431-11	CARBON	15K	5%	1/4W
R218	1-247-887-00	CARBON	220K	5%	1/4W
R219	1-249-430-11	CARBON	12K	5%	1/4W
R220	1-249-426-11	CARBON	5.6K	5%	1/4W
R221	1-247-882-11	CARBON	130K	5%	1/4W
R223	1-249-404-00	CARBON	82	5%	1/4W
R224	1-247-889-00	CARBON	270K	5%	1/4W
R225	1-249-430-11	CARBON	12K	5%	1/4W
R226	1-249-406-11	CARBON	120	5%	1/4W
R301	1-249-437-11	CARBON	47K	5%	1/4W
R302	1-249-417-11	CARBON	1K	5%	1/4W
R303	1-249-429-11	CARBON	10K	5%	1/4W
R304	1-215-455-00	METAL	27K	1%	1/6W
R305	1-249-421-11	CARBON	2.2K	5%	1/4W
R306	1-249-421-11	CARBON	2.2K	5%	1/4W

Ref.No.	Part No.	Description				
R307	1-247-864-11	CARBON	24K	5%	1/4W	
R308	1-249-429-11	CARBON	10K	5%	1/4W	
R309	1-249-414-11	CARBON	560	5%	1/4W	
R310	1-249-409-11	CARBON	220	5%	1/4W	
R311	1-249-409-11	CARBON	220	5%	1/4W	
R312	1-249-417-11	CARBON	1K	5%	1/4W	
R313	1-249-429-11	CARBON	10K	5%	1/4W	
R314	1-249-421-11	CARBON	2.2K	5%	1/4W	
R315	1-249-421-11	CARBON	2.2K	5%	1/4W	
R316	1-249-429-11	CARBON	10K	5%	1/4W	
R317	1-249-429-11	CARBON	10K	5%	1/4W	
R318	1-249-429-11	CARBON	10K	5%	1/4W	
R319	1-249-433-11	CARBON	22K	5%	1/4W	
R320	1-249-429-11	CARBON	10K	5%	1/4W	
R321	1-249-437-11	CARBON	47K	5%	1/4W	
R322	1-247-828-11	CARBON	750	5%	1/4W	
R323	1-249-421-11	CARBON	2.2K	5%	1/4W	
R324	1-249-433-11	CARBON	22K	5%	1/4W	
R325	1-249-417-11	CARBON	1K	5%	1/4W	
R326	1-249-434-11	CARBON	27K	5%	1/4W	
R327	1-249-430-11	CARBON	12K	5%	1/4W	
R328	1-249-423-11	CARBON	3.3K	5%	1/4W	
R329	1-247-838-00	CARBON	2K	5%	1/4W	
R330	1-247-852-11	CARBON	7.5K	5%	1/4W	
R331	1-249-417-11	CARBON	1K	5%	1/4W	
R332	1-249-417-11	CARBON	1K	5%	1/4W	
R333	1-249-432-11	CARBON	18K	5%	1/4W	
R334	1-249-432-11	CARBON	18K	5%	1/4W	
R335	1-249-387-11	CARBON	3.3	5%	1/4W	
R336	1-249-387-11	CARBON	3.3	5%	1/4W	
R337	1-249-409-11	CARBON	220	5%	1/4W	
R338	1-249-423-11	CARBON	3.3K	5%	1/4W	
R401	1-249-411-11	CARBON	330	5%	1/4W	
R402	1-249-411-11	CARBON	330	5%	1/4W	
R403	1-249-411-11	CARBON	330	5%	1/4W	
R404	1-249-411-11	CARBON	330	5%	1/4W	
R405	1-249-419-11	CARBON	1.5K	5%	1/4W	
R406	1-249-418-11	CARBON	1.2K	5%	1/4W	
R501	1-249-438-11	CARBON	56K	5%	1/4W	
R502	1-249-436-11	CARBON	39K	5%	1/4W	
R503	1-249-437-11	CARBON	47K	5%	1/4W	
R504	1-249-440-11	CARBON	82K	5%	1/4W	
R505	1-247-881-00	CARBON	120K	5%	1/4W	
R506	1-249-438-11	CARBON	56K	5%	1/4W	
R507	1-249-440-11	CARBON	82K	5%	1/4W	
R508	1-247-872-11	CARBON	51K	5%	1/4W	
R509	1-247-883-00	CARBON	150K	5%	1/4W	
R510	1-247-880-11	CARBON	110K	5%	1/4W	
R511	1-249-440-11	CARBON	82K	5%	1/4W	
R512	1-247-885-00	CARBON	180K	5%	1/4W	
R513	1-247-876-11	CARBON	75K	5%	1/4W	
R514	1-249-438-11	CARBON	56K	5%	1/4W	
R515	1-249-438-11	CARBON	56K	5%	1/4W	
R516	1-249-438-11	CARBON	56K	5%	1/4W	
R517	1-247-881-00	CARBON	120K	5%	1/4W	
R518	1-247-887-00	CARBON	220K	5%	1/4W	

Ref.No.	Part No.	Description				
RV101	1-228-994-00	RES, ADJ, CARBON 10K				(REC LEVEL)
RV102	1-228-994-00	RES, ADJ, CARBON 10K				(PB LEVEL)
RV201	1-228-994-00	RES, ADJ, CARBON 10K				(REC LEVEL)
RV202	1-228-994-00	RES, ADJ, CARBON 10K				(PB LEVEL)
RV301	1-238-262-11	RES, VAR, CARBON 20K/20K				(REC LEVEL)
RV302	1-238-263-11	RES, VAR, CARBON 5K/5K				(BALANCE)
RV303	1-241-032-11	RES, VAR, CARBON 5K				(BIAS)
RY301	1-515-726-11	RELAY				
S301	1-571-292-11	SWITCH, PUSH (1 KEY) (DOLBY NR)				
S302	1-571-292-11	SWITCH, PUSH (1 KEY) (DOLBY NR)				
S401	1-570-393-21	SWITCH, PUSH (1 KEY) (POWER)				
S501	1-571-736-11	SWITCH, LEAF				
S502	*1-572-335-11	SWITCH, LEAF				
S503	1-571-736-11	SWITCH, LEAF				
S504	*1-572-335-11	SWITCH, LEAF				
S505	△.1-552-535-00	(E)..SWITCH POWER & VOLTAGE CHANGE				
T301	1-433-365-11	TRANSFORMER, BIAS OSCILLATION				
T401	△.1-449-390-11	(AEP,UK).....TRANSFORMER, POWER				
	△.1-449-593-11	(US,Canadian)...TRANSFORMER, POWER				
	△.1-449-388-11	(E).....TRANSFORMER, POWER				

ACCESSORY & PACKING MATERIAL

- 1-559-533-11 CORD, CONNECTION
- * 3-701-630-00 BAG, POLYETHYLENE
- 3-751-635-41 (AEP).....MANUAL, INSTRUCTION
- 3-751-635-21 (US,Canadian,UK)..MANUAL, INSTRUCTION
- 3-751-635-51 (WG).....MANUAL, INSTRUCTION
- 3-751-635-31 (Canadian)...MANUAL, INSTRUCTION
- 3-703-450-04 (US).....INSTRUCTION
- *3-349-028-81 INDIVIDUAL CARTON
- *3-349-037-01 CUSHION

<p>Note: The components identified by mark  or dotted line with mark  are critical for safety. Replace only with part number specified.</p>	<p>Note: Les composants identifiés par une marque  sont critiques pour la sécurité. Ne les remplacer que par une pièce portant le numéro spécifié.</p>
--	--