

TC-FX44 / FX44B

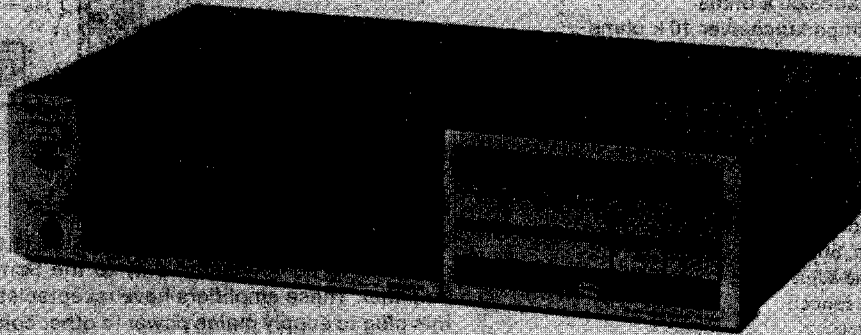

PHOTO : TC-FX44

TC-FX44 (Silver type)
 US Model
 Canadian Model
 AEP Model
 UK Model
 E Model

TC-FX44B (Black type)
 AEP Model

1444

Dolby and the double-D symbol are the trade marks of Dolby Laboratories Licensing Corporation. Noise reduction system manufactured under license from Dolby Laboratories Licensing Corporation.

STEREO CASSETTE DECK

SPECIFICATIONS

Recording system 4-track 2-channel stereo
 Fast-forward and rewind time Approx. 100 sec. (with C-60 cassette)
 Bias frequency 105 kHz
 Signal-to-noise ratio (NAB, at peak level)

Cassette	Dolby NR switch	OFF	B-TYPE ON	C-TYPE ON
TYPE IV (Sony METALLIC)		58 dB	65 dB	71 dB
TYPE III (Sony FeCr)		59 dB	66 dB	72 dB
TYPE II (Sony EHF or CD-α)		56 dB	63 dB	69 dB
TYPE I (Sony HFX or BHF)		54 dB	61 dB	67 dB

Total harmonic distortion 1.0% (with Sony METALLIC and FeCr cassettes)
 Frequency response DOLBY NR OFF, FILTER OFF
 • With TYPE IV cassette (Sony METALLIC)
 20 - 18,000 Hz
 30 - 16,000 Hz (±3 dB)
 30 - 13,000 Hz (±3 dB, 0 VU recording)
 30 - 16,000 Hz (DIN)
 • With TYPE III cassette (Sony FeCr)
 20 - 18,000 Hz
 30 - 16,000 Hz (±3 dB)
 30 - 16,000 Hz (DIN)
 • With TYPE II cassette (Sony EHF or CD-α)
 20 - 17,000 Hz
 30 - 15,000 Hz (±3 dB)
 30 - 15,000 Hz (DIN)
 • With TYPE I cassette (Sony HFX or BHF)
 20 - 16,000 Hz
 30 - 14,000 Hz (DIN)

SAFETY-RELATED COMPONENT WARNING!!

COMPONENTS IDENTIFIED BY SHADING AND MARK  ON THE SCHEMATIC DIAGRAMS, EXPLODED VIEWS AND IN THE PARTS LIST ARE CRITICAL TO SAFE OPERATION. REPLACE THESE COMPONENTS WITH SONY PARTS WHOSE PART NUMBERS APPEAR AS SHOWN IN THIS MANUAL OR IN SUPPLEMENTS PUBLISHED BY SONY.

ATTENTION AU COMPOSANT AYANT RAPPORT À LA SÉCURITÉ!

LES COMPOSANTS IDENTIFIÉS PAR UNE TRAME ET UNE MARQUE  SUR LES DIAGRAMMES SCHEMATIQUES, LES VUES EXPLODÉES ET LA LISTE DES PIÈCES SONT CRITIQUES POUR LA SÉCURITÉ DE FONCTIONNEMENT. NE REMPLACER CES COMPOSANTS QUE PAR DES PIÈCES SONY DONT LES NUMÉROS SONT DONNÉS DANS CE MANUEL OU DANS LES SUPPLÉMENTS PUBLIÉS PAR SONY.



MICROFILM

Tape Transport Mechanism TCM-130V2

SONY

SERVICE MANUAL

- Contined on page 2 -

TC-FX44 / FX44B

Wow and flutter	US, Canadian model: 0.05 % WRMS AEP, UK, E model: 0.05 % WRMS (NAB) ± 0.14 % (DIN)
Inputs	Microphone inputs (phone jacks) Sensitivity 0.25 mV (-70 dB) For a low-impedance microphone Line inputs (phono jacks) Sensitivity 77.5 mV (-20 dB) Input impedance 50 k ohms
Outputs	Line outputs (phono jacks) Output level 0.435 V (-5 dB) at load impedance 50 k ohms Load impedance over 10 k ohms Headphone output Output level -28 dB at load impedance of 8 ohms

General

Power requirements	US, Canadian model: 120 V ac, 60 Hz AEP model: 220 V ac, 50/60 Hz (240 V ac adjustable by authorized Sony personnel) UK model: 240 V ac, 50/60 Hz (220 V ac adjustable by authorized Sony personnel) E model: 110, 120, 220 or 240 V ac adjustable, 50/60 Hz
Power consumption	14 watts US, Canadian model 15 watts AEP, UK, E model
Dimensions	Approx. 430 × 105 × 275 mm (w/h/d) (17 × 4 ¹ / ₄ × 10 ⁷ / ₈ inches) including projecting parts and controls
Weight	Approx. 4.3 kg (9 lbs 8 oz)

0 dB = 0.775 V

MODEL IDENTIFICATION — Specification Label —

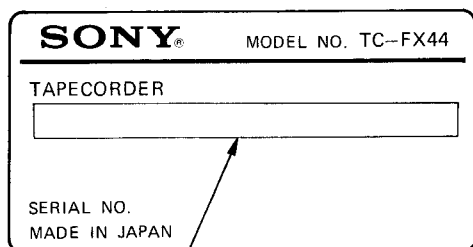

US, Canadian model:	AC: 120V	60Hz	14W
AEP model:	AC: 220V ~	50/60Hz	15W
UK model:	AC: 240V ~	50/60Hz	15W
E model:	AC: 110, 120, 220, 240V ~	50/60Hz	15W

— Power Cord —

E1 model: euro-plug 1-555-734-00 E2 model: parallel-blade plug 1-551-473-31

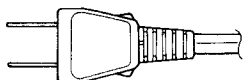
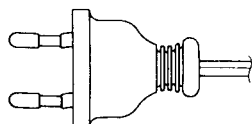

NOTES ON REPAIR

When the mech deck is operated with the set in an upside-down position, misoperation may result. For repair while operating the mech deck, perform with the set in its normal position or standing on its side.

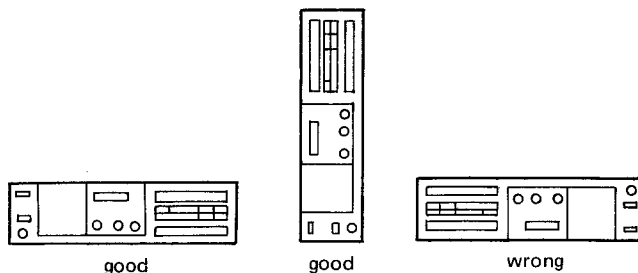

For the Customers in the UK Model

The mains lead plug of your apparatus is a 3-pin type especially designed to be connected only to the Sony TA-AX22 or TA-AX44 amplifier. These amplifiers have receptacles on the rear to receive this plug to supply mains power to other components of your audio system. To connect the apparatus directly to a mains power point in your house, firmly insert the 3-pin plug into the supplied mains lead adaptor.

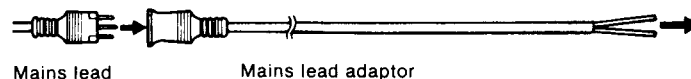

CAUTION

Connect the 3-pin plug only to the mains outlet on the components mentioned above or to the supplied mains lead adaptor.

Important

The wires in the mains lead adaptor are coloured in accordance with the following code:

Blue: Neutral
Brown: Live

As the colours of the wires in the mains lead adaptor of this apparatus may not correspond with the coloured markings identifying the terminals in your plug, proceed as follows:

The wire which is coloured blue must be connected to the terminal which is marked with the letter N or coloured black.

The wire which is coloured brown must be connected to the terminal which is marked with the letter L or coloured red.

OPERATING VOLTAGE (E Model)

Before connecting the unit to the power source, check that the operating voltage of your unit is the same as the local power line voltage.

The voltage selector is located on the rear panel. If the selector must be reset, **disconnect the ac power cord** and turn the selector with a coin so that the arrow on the selector points to the appropriate voltage.

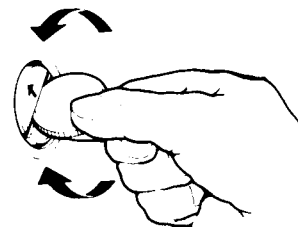

TC-FX44 / FX44B TC-FX44 / FX44B

SECTION 1 OUTLINE

1-1. BLOCK DIAGRAM

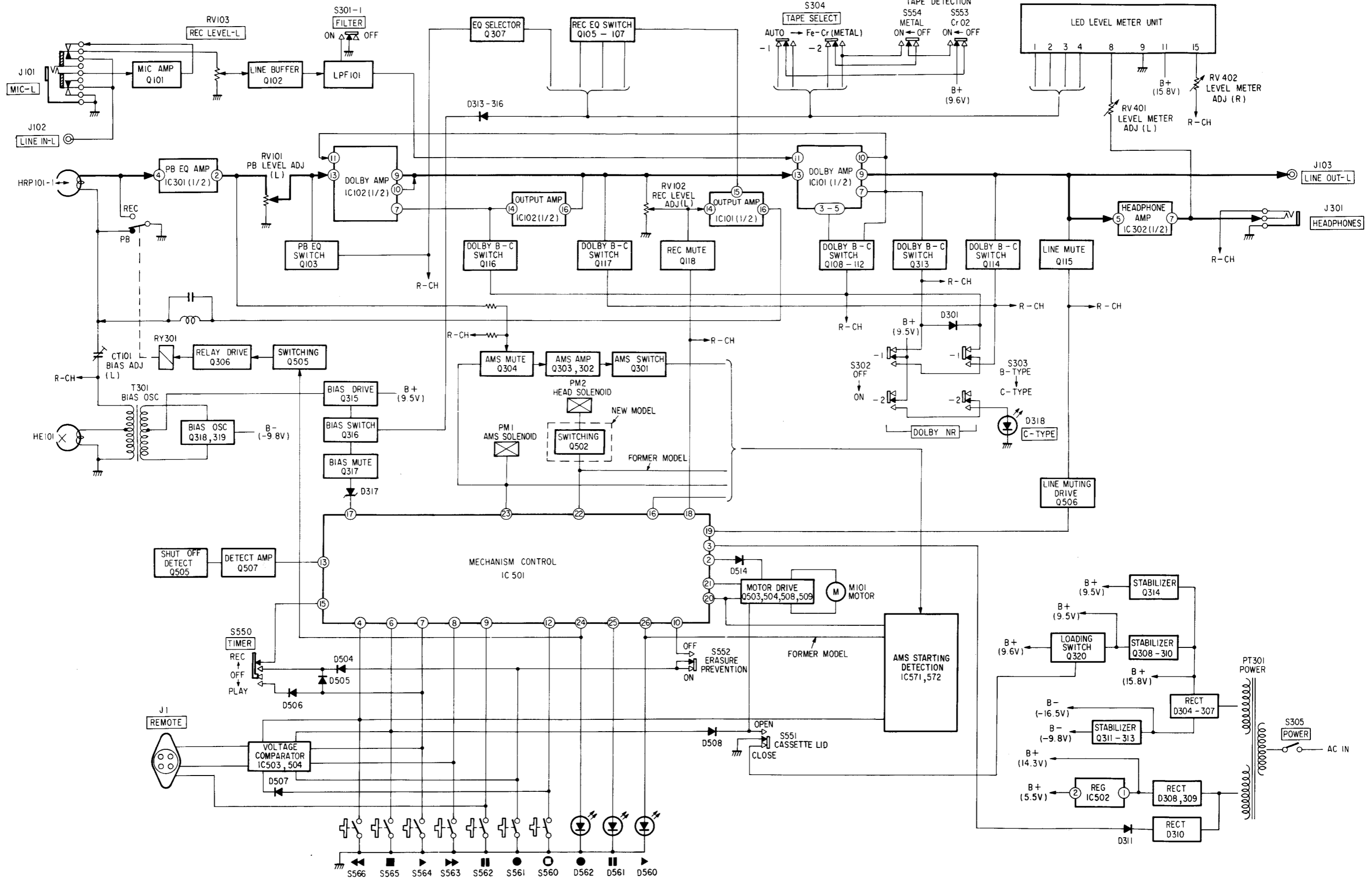

1-2. GENERAL DESCRIPTION

FEATURES

Dolby NR C-type noise reduction system

In addition to the conventional B-type Dolby NR system, the TC-FX44/FX44B employs the newly-developed C-type Dolby NR system which reduces tape noise twice as effectively as the B-type system. The C-type system also incorporates an anti-saturation network to improve the high-frequency dynamic range by 4 dB at 10 kHz.

Full-logic "feather-touch" operation

At the slightest touch, the "feather-touch" function buttons which control a microprocessor enable you to switch directly from one mode to another without going through the stop mode.

Automatic tape select system

The tape type is automatically detected and the recorder is adjusted to its optimum bias current for recording and the optimum equalization for both recording and playback by simply inserting the cassette in the cassette holder.

The AMS (Automatic Music Sensor) system

Using this system, it is possible to locate the beginning of the selection being played or the following selection. The AMS searches either forward or reverse for the blank space between selections. Playback will begin automatically from the beginning of the selection.

Auto play

The auto play function makes automatic replay possible promptly after the tape is rewound to the beginning.

Remote control operation

Using the optional RM-44, RM-50 or RM-80 remote control unit, various operations—recording, playback, AMS, record muting operation, etc.—can be remotely controlled. When the RM-65 synchro remote control unit is used to connect this cassette deck with a turntable equipped with a synchro remote control jack or a TC-PB5 stereo cassette player, the operation of the cassette deck and the turntable or TC-PB5 will be synchronized.

FUNCTION OF CONTROLS

The numbers in the photo are keyed to the following explanations.

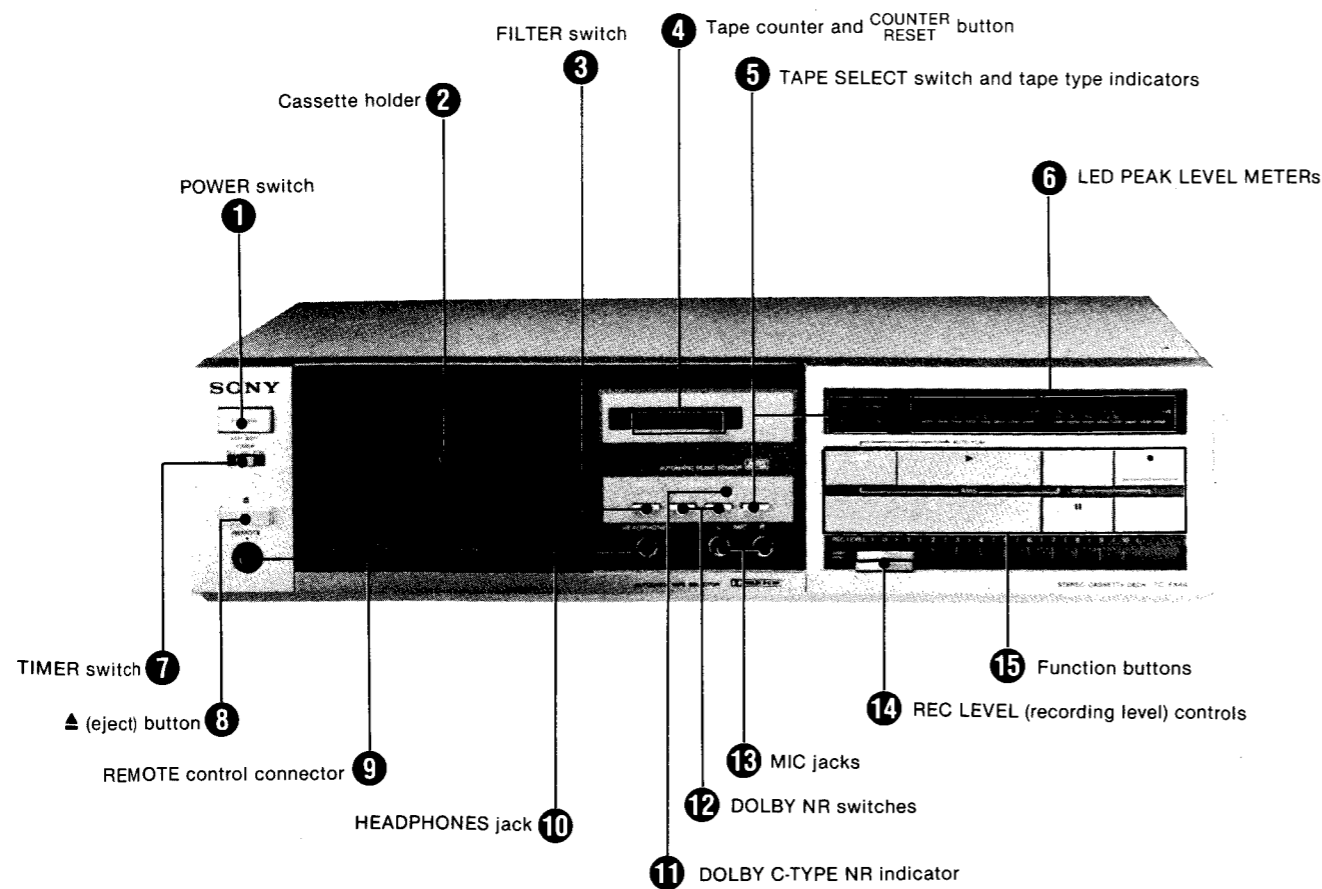

CONNECTIONS

Notes

- Turn the amplifier off before making any connection.
- Be sure to insert the plugs firmly into the jacks. Loose connections may cause hum and noise.
- The red plug of the supplied connecting cord should be connected to the red jack (R : right channel) and the other plug to the white jack (L : left channel).

When recording through the LINE IN jacks, be sure to disconnect any connector to the MIC jacks. If both the LINE IN and MIC jacks are engaged, only input to the MIC jack will be recorded.

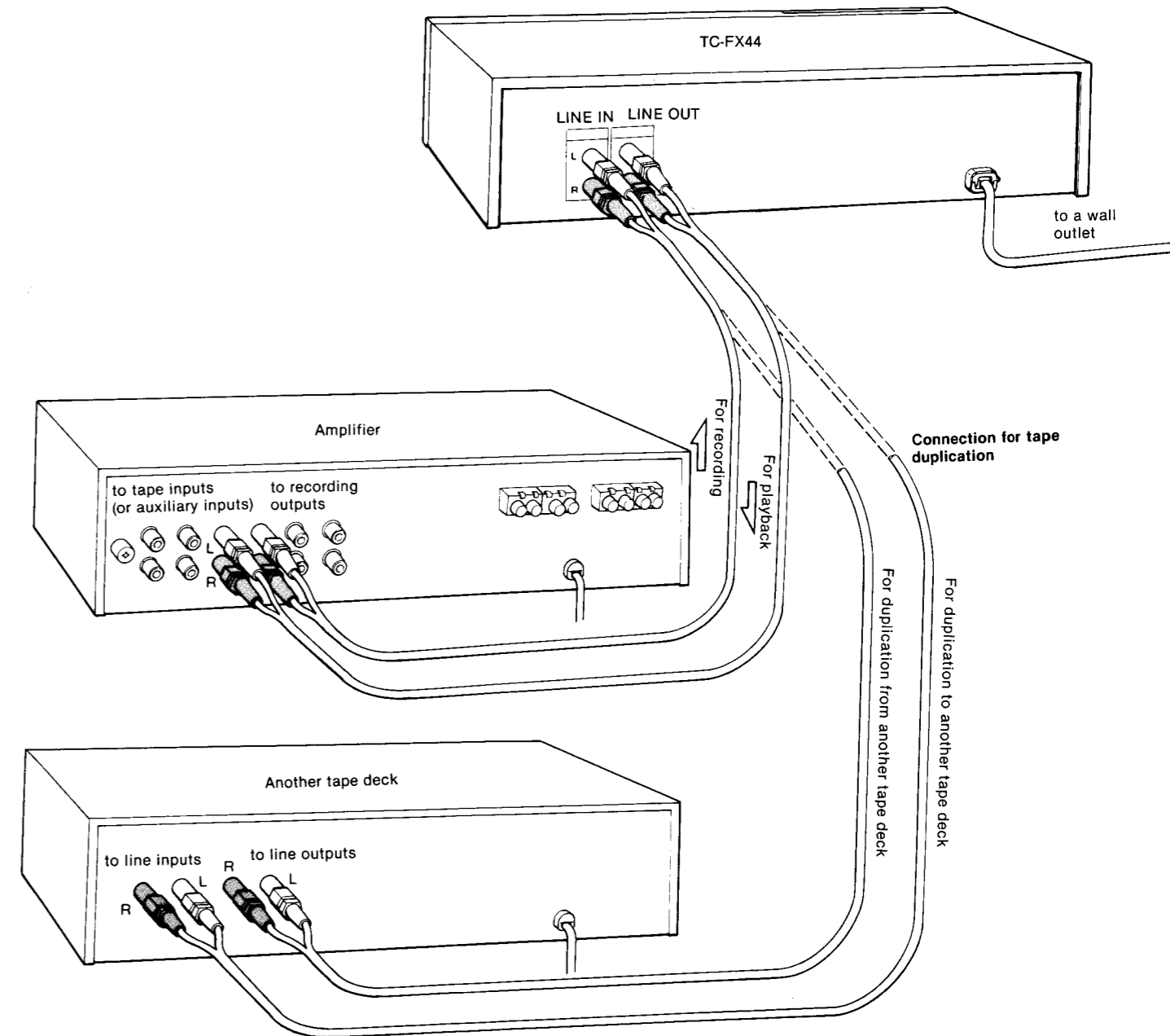

1 POWER switch

This turns the power on or off. The peak level meters illuminate when the unit is turned on.

2 Cassette holder

3 FILTER switch

Normally set this switch to OFF (□).

When recording FM stereo broadcasts with the Dolby NR system, set it to ON (▣) if the 19 kHz pilot signal and the 38 kHz subcarrier have not been adequately suppressed by the FM tuner or receiver. If the tuner or the receiver suppresses such signals adequately (most high-quality tuners and receivers will), you do not have to set this switch to ON.

4 Tape counter and COUNTER RESET button

The tape counter provides a numerical reference point while recording which can be used to index a recorded cassette. To reset to zero, press the COUNTER
RESET button.

5 TAPE SELECT switch and tape type indicators

Generally set this switch to AUTO (□). The automatic tape select system will then operate. When using a TYPE III (Fe-Cr) cassette or a TYPE IV (METAL) cassette which has no METAL tape detector slots, depress this switch to set it to the III Fe-Cr (IV METAL) position (▣). See page 9.

When inserting a cassette, one of the tape type indicators will light up depending on the type of tape and the position of the TAPE SELECT switch.

6 LED PEAK LEVEL METERS

These meters show the peak input level of each channel during recording, and recorded levels in the playback mode. They follow the transient peaks of high-level inputs that are too brief to be followed by conventional VU meters so that the optimum recording level can be accurately set.

7 TIMER switch

You can set the unit to record or play back at a predetermined time by connecting any commercially available timer. To record, set this timer switch to REC. To playback, set it to PLAY. See "Timer-activated recording and playback" on page 13.

8 ▲ (eject) button

Press this button to open the cassette holder.

9 REMOTE control connector

Connect the optional RM-44 (wireless), RM-50 (wired) or RM-80 (wireless) remote control unit to operate the tape transport functions from a distance. The tape deck function buttons are still operative when the remote control unit is connected.

The RM-65 synchro remote control unit can also be connected to this connector. Using this unit, the operation of the TC-FX44 and a turntable equipped with a synchro remote control jack or a TC-PB5 stereo cassette player will be synchronized.

Read the instruction manual of the remote control unit before operating.

10 HEADPHONES jack

Headphones may be inserted either to monitor the input signals to be recorded or to listen to a recording in the playback mode.

11 DOLBY C-TYPE NR indicator

This indicator illuminates when the DOLBY NR switches are at the C-TYPE DOLBY NR position.

12 DOLBY NR switches

The left switch turns the Dolby NR* (Noise Reduction) system on and off and the right switch selects either the B-type or C-type Dolby NR system.

To record with the Dolby NR process, depress the ON/OFF switch to the ON position and choose between B-TYPE (□) and C-TYPE (▣).

To record without the Dolby NR process, press the ON/OFF switch again to release.

When playing back, set these switches to the same position used in recording.

For details about the Dolby NR system, see page 14.

* "Dolby" and the double-D symbol are trade marks of the Dolby Laboratories. Noise reduction system manufactured under license from Dolby Laboratories.

13 MIC jacks

Any low-impedance microphone equipped with a phone plug may be used. If your microphone is equipped with a mini plug, you will need a plug adaptor.

14 REC LEVEL (recording level) controls

These controls adjust the recording level. The upper slide bar is for the left channel and the lower for the right channel.

15 Function buttons

It is possible to switch directly from one mode to another. The indicator lamps light when the tape deck is in the forward, record or pause mode.

- ◀ (rewind) button : Press this button to rewind the tape.
- ▶ (forward) button : Press this button to play the tape back. To record, press this button while holding the ● button down.
- ▶▶ (fast-forward) button : Press this button to advance the tape rapidly.
- (record) button : Press this button together with the ▶ button to start recording. Also press this button before adjusting the recording level.
- (stop) button : To stop the tape, press this button. The tape will stop automatically when it is completely wound up in either direction.
- || (pause) button : To pause for a moment during recording or playback, press this button. This button is also used to control more precisely the start of recording and to release the record muting mode.
- (record muting) button : Press this button to eliminate unwanted material and to insert a blank space during recording. See "Record muting" on page 11.

TC-FX44/FX44B

RECORDING

TO RECORD

The numbers in this diagram indicate the sequence to be followed.

Set the input selector of the amplifier to the desired program source.

1

Set the TIMER switch to OFF and depress the POWER switch to ON.

Note



The logic-controlled function buttons do not activate until 4 seconds after the POWER switch is turned on. Wait until the indicator goes off.

5

Play the program source to be recorded.

If you want to record the program source connected to the LINE IN jacks, unplug the microphone.

2

Press the button and insert a cassette.

4 Depress when recording using the Dolby NR system (ON). Press again for the OFF position (OFF).

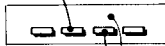

Depress for C-type Dolby NR system (ON). The C-TYPE indicator will illuminate. Press again and release for B-type (OFF).

3

Check that the tape type indicator corresponds to the type of tape inserted. Depress the TAPE SELECT switch when using a TYPE III (Fe-Cr) cassette or a TYPE IV (METAL) cassette which has no METAL tape detector slots. For more details, see "Automatic tape select system" on the next page.

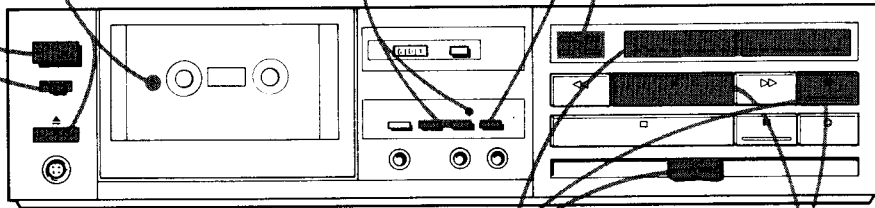

6

Adjust the recording level.

1 Press.

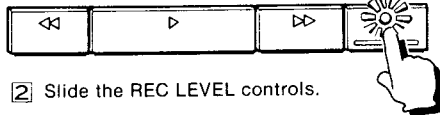

2 Slide the REC LEVEL controls.

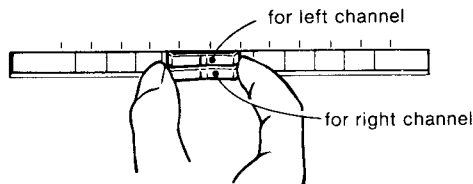

Adjust the recording level so that the peaks fall momentarily within the recommended maximum peak level meter reading shown on page 10, depending on the type of tape being used.

7

Start recording.

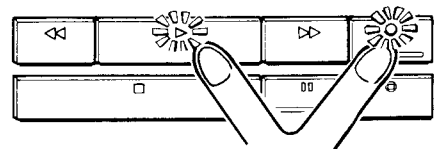

Press simultaneously.

Note on the TIMER switch

If the power is turned on when this switch is set to the REC or PLAY position, recording or playback will start automatically in 4 seconds. To avoid accidental erasure of previously-recorded material, check that the TIMER switch is set to OFF before turning on the POWER switch.

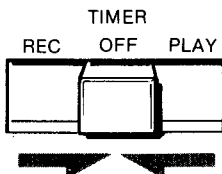

CASSETTE INSERTION

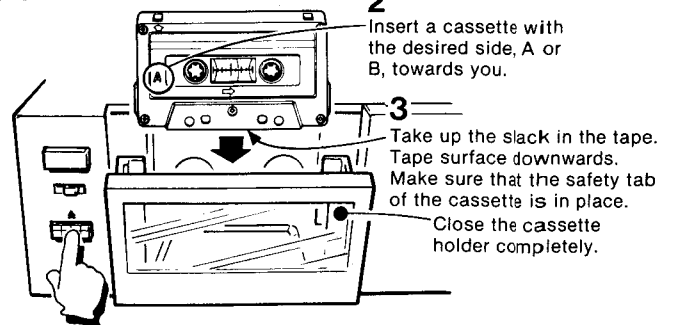

1 Press to open the cassette holder.

AUTOMATIC TAPE SELECT SYSTEM

With the TAPE SELECT switch at the AUTO position (\square), this automatic tape select system is actuated by the detector slots of certain cassettes and automatically sets the optimum recording and playback characteristics. The tape type detected will be shown by the indicator.

	TYPE I (NORM) cassette	TYPE II (CrO ₂) cassette	TYPE III (Fe-Cr) cassette	TYPE IV (METAL) cassette	
Tape detector slots	 the tab	 CrO ₂ tape detector slots	same as the TYPE I cassette	 METAL tape detector slots	 METAL tape which has no METAL tape detector slots
Tape type indicator	 I	 II	 III	 IV	 IV

Note

As shown in the above illustrations, when inserting TYPE III (Fe-Cr) cassettes and TYPE IV (METAL) cassettes which have no METAL tape detector slots, the correct tape type indicator does not light up and the automatic tape select system cannot work properly.

Set the TAPE SELECT switch to the III Fe-Cr (IV METAL) (\square) position when using these cassettes.

When no cassette is in the holder, IV METAL indicator lights up.

Tape list (US, Canadian model)

Tapes (C-60 and C-90)	Type of tape
SONY: LNX, SHF, HFX MAXELL: UD, UD-XL I, XL I-S SCOTCH: MASTER I AMPEX: GRAND MASTER I FUJI: FX-I MEMOREX: MRX-1 TDK: AD, AD-X	TYPE I (NORMAL)
SONY: UCX-S, EHF MAXELL: UD-XL II, XLII-S SCOTCH: MASTER II AMPEX: GRAND MASTER II FUJI: FX-II MEMOREX: HIGH BIAS II TDK: SA, SA-X	TYPE II (CrO ₂)
SONY: FeCr SCOTCH: MASTER III BASF: PROFESSIONAL III	TYPE III (Fe-Cr)
SONY: METALLIC Other metal tapes	TYPE IV (METAL)

Tape list (AEP, UK, E model)

Tapes (C-60 and C-90)	Type of tape
SONY: AHF, BHF, CHF BASF: LH-X, Professional I MAXELL: UD, UD-XL I, XL I-S SCOTCH: MASTER I AGFA: SUPER FERRO DYNAMIC FUJI: FX-I PHILIPS: SUPER FERRO-I TDK: AD	TYPE I (NORMAL)
SONY: UCX-S, CD- α BASF: Professional II MAXELL: UD-XLII, XLII-S SCOTCH: MASTER II AGFA: STEREO CHROM FUJI: FX-II PHILIPS: CHROMIUM TDK: SA, SA-X	TYPE II (CrO ₂)
SONY: FeCr BASF: Professional III SCOTCH: MASTER III AGFA: CARAT PHILIPS: FERRO CHROMIUM	TYPE III (Fe-Cr)
SONY: METALLIC Other metal tapes	TYPE IV (METAL)

MORE ACCURATE RECORDING STARTS

You can use the **II** (pause) button to start recording more accurately than is possible when recording is started by pressing both the **●** button and the **▶** button.

- 1 After completing step 5, press the **II** button.
- 2 Hold the **●** button down and press the **▶** button.
- 3 Adjust the recording level.
- 4 At the moment you wish to start recording, you need only press the **II** button again.

TC-FX44/FX44B

TO ADJUST THE RECORDING LEVEL

Adjust the recording level while reading the input level of the program source to be recorded on the peak level meters.

The peak level meters instantaneously register the input signal level while conventional VU meters have a lag so that they many times do not accurately reflect a strong input of short duration.

This difference in response time is reflected in the different scales of the VU meters and the peak level meters. The -4 dB point on the peak level meter scale corresponds to the 0 VU point on a VU meter scale.

The recording level should be set as high as possible while still avoiding distortion, and this will depend on the type of tape being used.

The following table will provide you with a starting point in setting the recording level of various kinds of programs when using Sony cassettes.

Recommended maximum peak level meter reading (US, Canadian model)

Type of tape	Sony cassettes	PEAK LEVEL METER							
		-dB		0 VU					+dB
		∞	20	7	4	0	3	5	8
TYPE I	LNx, HFX, SHF	[Hatched]		[Hatched]		[Hatched]		[Hatched]	
		[Solid]		[Solid]		[Solid]		[Solid]	
TYPE II	EHF	[Hatched]		[Hatched]		[Hatched]		[Hatched]	
		[Solid]		[Solid]		[Solid]		[Solid]	
TYPE III	FeCr	[Hatched]		[Hatched]		[Hatched]		[Hatched]	
		[Solid]		[Solid]		[Solid]		[Solid]	
TYPE IV	METALLIC	[Hatched]		[Hatched]		[Hatched]		[Hatched]	

[Hatched] for low and mid freq. range programs (vocal, etc.)
 [Solid] for mid and high freq. range programs (piano, guitar, etc.)

Recommended maximum peak level meter reading (AEP, UK, E model)

Type of tape	Sony cassettes	PEAK LEVEL METER							
		-dB		0 VU					+dB
		∞	20	7	4	0	3	5	8
TYPE I	AHF, BHF, CHF	[Hatched]		[Hatched]		[Hatched]		[Hatched]	
		[Solid]		[Solid]		[Solid]		[Solid]	
TYPE II	CD-α	[Hatched]		[Hatched]		[Hatched]		[Hatched]	
		[Solid]		[Solid]		[Solid]		[Solid]	
TYPE III	FeCr	[Hatched]		[Hatched]		[Hatched]		[Hatched]	
		[Solid]		[Solid]		[Solid]		[Solid]	
TYPE IV	METALLIC	[Hatched]		[Hatched]		[Hatched]		[Hatched]	

[Hatched] for low and mid freq. range programs (vocal, etc.)
 [Solid] for mid and high freq. range programs (piano, guitar, etc.)

In general, adjust the recording level by making sure that at the highest signal level, the meters deflect only to the readings shown in the above table.

If the meters deflect continuously to high-level readings, the setting is too high and the recording will be distorted. If the meters deflect only to about -10 dB, the setting is too low and the recording will be noisy. However, when recording programs containing many strong, sharp pulses, the recording level may be too high if adjusted in this way. Since the maximum output level of any tape is lower in the higher frequencies than in the lower frequencies, tape saturation at the higher frequencies occurs at lower input levels. Consideration has to be given to the program source to be recorded, as well as to the characteristics of the cassette to be used, since each cassette, even cassettes with the same type tape, may have different characteristics.

Notes

● While these settings are optimum for Sony cassettes, you may want to change these settings when using cassettes produced by other manufacturers.

● The peak level meters show the input level during recording and the recorded level during playback. If the recording is distorted at high input levels, when the recording is played back the meters will indicate these distorted passages as levels lower than the actual input levels.

PLAYBACK

The numbers in this diagram indicate the sequence to be followed.

Set the input selector of the amplifier to TAPE.

1

Set the TIMER switch to OFF and depress the POWER switch to ON.

2

Press the  button and insert a cassette.

3

Check that the tape type indicator corresponds to the type of tape inserted. Depress the TAPE SELECT switch when using a TYPE III (Fe-Cr) cassette or a TYPE IV (METAL) cassette which has no METAL tape detector slots.

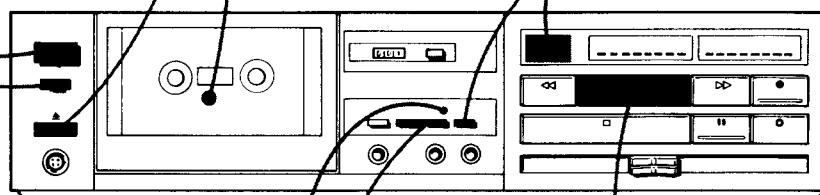

Note

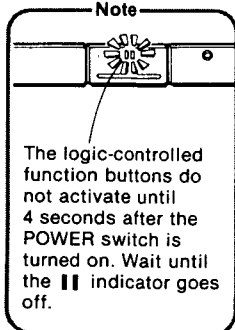

5

Press the  button. Playback will begin.

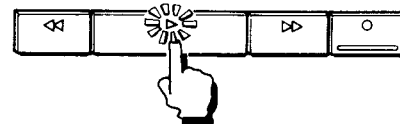

4



C-TYPE
B-TYPE



Depress for a tape recorded with C-type Dolby NR (). The C-TYPE indicator will illuminate.

Depress () when playing back a tape which has been recorded using the Dolby NR system.

ERASING



When the tape deck functions in recording mode, the erase head automatically erases any previously recorded material.

To erase without recording:

- 1 Make sure that the safety tab of the cassette is in place, or that the tab slot is covered with plastic tape.
- 2 Set the REC LEVEL controls fully to "0". (Disconnecting all inputs will result in a more complete erasure.)
- 3 Insert the cassette to be erased and check that the tape type indicator corresponds to the type of tape inserted. Depress the TAPE SELECT switch if the indicator and the tape do not correspond.
- 4 While holding the  button down, press the  button.



RECORD MUTING

By pressing the  (record muting) button during recording, four seconds interspacing is provided automatically, eliminating unwanted program material such as broadcasting commercials. While the record muting is operating, the incoming signal is not recorded on the tape but it continues to register on the meters and feed to the monitor so that you know exactly what is going on.





1 Press the  button when the segment you do not want to record begins. The indicator of the  button will blink, and the tape path will pause automatically after four seconds.

2 When you want to resume recording, press the  button.

To insert a blank less than four seconds long

Press the  button to mute recording. Press the  button when you want to resume recording.

To insert a blank over four seconds long

Hold down the  button for as long as you want the blank segment on the tape to be. After four seconds, the indicator of the  button will blink more rapidly. When you release the  button, the tape deck will be in the pause mode. When you want to resume recording, press the  button to release the pause mode.

AUTO PLAY AND AMS (AUTOMATIC MUSIC SENSOR)

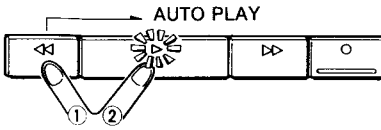
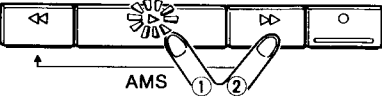
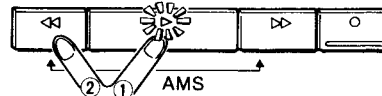
To start the playback from the beginning after rewinding	To play from the beginning of the following selection	To play from the beginning of the selection being played
<p style="text-align: center;">AUTO PLAY</p>	<p style="text-align: center;">AMS in the fast-forward mode</p>	<p style="text-align: center;">AMS in the rewind mode</p>
 <p>Press the ► button while holding down the ◀ button.</p> <p>After the tape is completely rewound, the rewind mode will be disengaged and the tape will automatically replay.</p>	 <p>Press the ►► button while holding down the ► button.</p> <p>After the tape runs in the fast-forward mode to the beginning of the following selection, playback begins.</p>	 <p>Press the ◀◀ button while holding down the ► button.</p> <p>After the tape is rewound to the beginning of the selection being played, playback begins.</p>

EXAMPLES OF THE AMS

If you operate the AMS while a program selection is being played. (during "Yesterday")

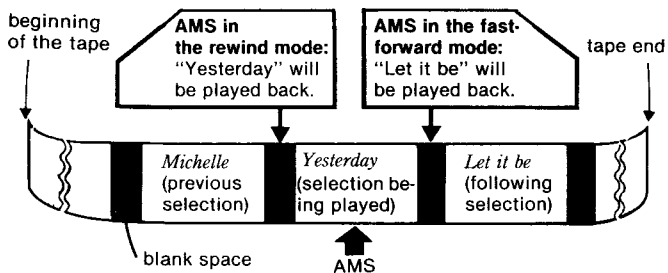

To assure the AMS operation

- For the AMS in the rewind mode, wait about 15 seconds after the selection starts before pressing the ◀◀ button; otherwise the previous selection will be played back.
- For the AMS in the fast-forward mode, do not press the ►► button immediately before the starting point of the following selection; otherwise playback might begin from the beginning of the selection after the following one.

Notes on the blank spaces

- Since the AMS works by searching out the blank spaces on a tape, it may not operate if there is noise in the space between selections, or if the space is less than 4 seconds long. The record muting facility of this tape deck can make a 4-second blank space that will assure the AMS operation on any recorded tape.
- If the recorded music includes a long pause, or if it continues for a time at sufficiently low volume, as may happen for instance with classical music, or if any selection is less than 20 seconds long, the AMS will treat it as a blank.

Others

- The ► button, ►► button and ◀◀ button of the RM-44, RM-50 and RM-80 remote control units (optional) are also useful for the AMS operation.

TIMER-ACTIVATED RECORDING AND PLAYBACK

By connecting any commercially available timer to the tape deck, the deck can be set to play back or record automatically at any desired time. As timers work in different ways, be sure to read the timer's instruction manual carefully.

To record a broadcast using a timer

- 1 Connect the tape deck, receiver and timer. Set the timer so that power is supplied to the connected equipment.

Power connection

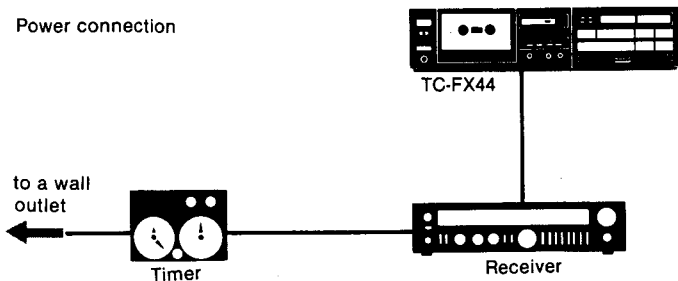

- 2 Turn on the receiver and tune in the station which will broadcast the program you want to record.
 - 3 Set the tape deck's TIMER switch to OFF.
 - 4 Insert a cassette. Make sure that the tab is intact or that plastic tape covers the tab slot.
 - 5 Turn on the tape deck and adjust the recording level.
 - 6 Set the timer for the desired time. (At this point power to the connected equipment will be cut off.)
 - 7 Set the tape deck's TIMER switch to REC.
- The tape deck is now ready to start recording at the time set on the timer.

To play back using a timer

The connections between equipment are the same as for recording using a timer.

- 1 Set the tape deck's TIMER switch to OFF.
- 2 Turn on the receiver and set the appropriate switches for playback.
- 3 Turn on the tape deck and insert the recorded cassette.
- 4 Set the timer for the desired time. (At this point power to the connected equipment will be cut off.)
- 5 Set the tape deck's TIMER switch to PLAY. The tape deck is now ready to start playback at the time set on the timer.

Note

The tape deck's TIMER switch will function properly only if the tape deck is turned on **after** the switch is set to REC or PLAY. If you want to change the setting of the switch, turn the power off first. Do not change the setting of the TIMER switch during the four second stand-by period immediately after the power is turned on.

MAINTENANCE

Cleaning of heads and tape path

We recommend cleaning after every 10 hours of operation. To make the best possible recordings, however, you should clean all surfaces over which the tape travels before every recording.

- 1 Press the \blacktriangle button to open the cassette holder. Remove the window as illustrated.

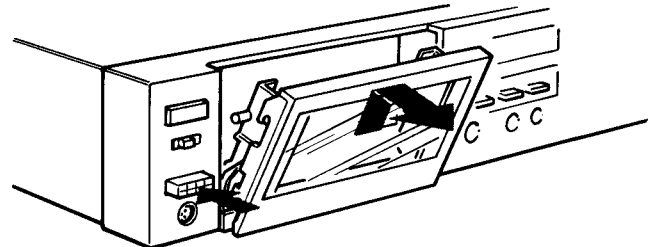

- 2 Wipe the heads, the pinch roller and the capstan with a cleaning tip slightly moistened with cleaning fluid or alcohol.

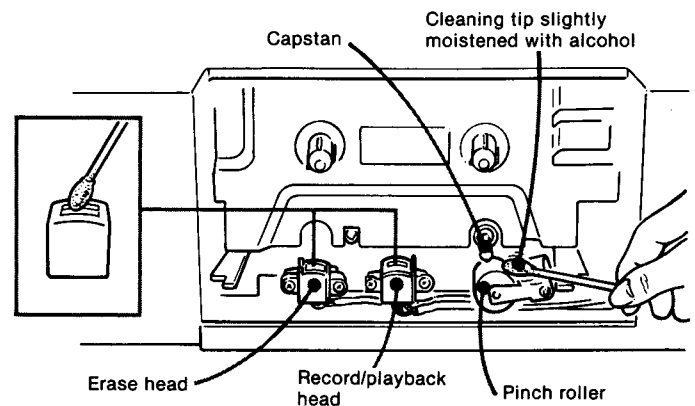

- 3 Replace the window.

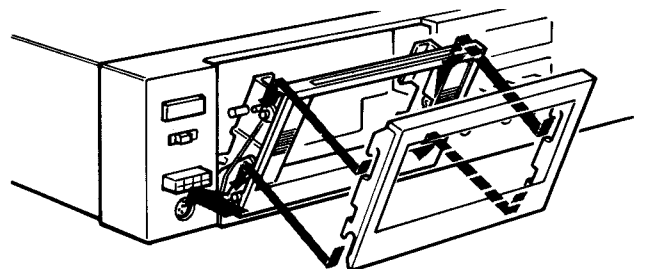

- After cleaning the heads and tape path, do not insert a cassette until the areas cleaned are completely dry.

Demagnetizing heads

After 20 to 30 hours of use, enough residual magnetism will have built up on the heads to begin to cause loss of high frequencies and hiss. At this time you should demagnetize the heads and all metal parts in the tape path with a commercially available head demagnetizer. Be sure that the tape deck is turned off while you demagnetize.

Cleaning the cabinet

Clean the cabinet, panel and controls with a soft cloth lightly moistened with a mild detergent solution. Do not use any type of abrasive pad, scouring powder or solvent such as alcohol or benzine.

DOLBY NR (NOISE REDUCTION) SYSTEM

There have been until recently just two types of Dolby NR system: the A-type for professional use, and the B-type, a simplified version of the A-type, employed by most consumer-grade cassette decks. Now, a third type of Dolby NR system is available, the C-type. The C-type system reduces tape noise much more effectively than the B-type system.

The basis of the Dolby NR system

During recording, low-level high-frequency signals, which tend to be obscured by tape hiss, are boosted so that they are substantially higher in level than any tape noise. When these signals are played back, the level is lowered to the original input level, while simultaneously the level of any tape noise is reduced to the same extent.

The Dolby B-type NR system thus reduces tape noise by 10 dB at 5 kHz. The C-type system reduces noise by 20 dB at 5 kHz. The Dolby C-type NR system also begins to take effect at frequencies lower than the B-type system.

Anti-saturation network

Normally, recording tape will saturate more easily at the higher frequencies. The Dolby C-type NR system incorporates a high frequency anti-saturation network. During recording, the anti-saturation network automatically reduces high-level high-frequency signals. When these signals are played back, the level is automatically boosted to the original input level. At 10 kHz, the tendency of the tape to saturate is reduced by 4 dB by the use of this network.

Playback of Dolby NR encoded tapes

For the best sound, lowest distortion, and most effective noise reduction, it is essential that a tape recorded using either the B-type or the C-type Dolby NR system be played back using the same system that was used during the recording process. We recommend that you label the cassettes you record as being either non-Dolby NR, Dolby B NR, or Dolby C NR.

Fig. 1 Encoding characteristics

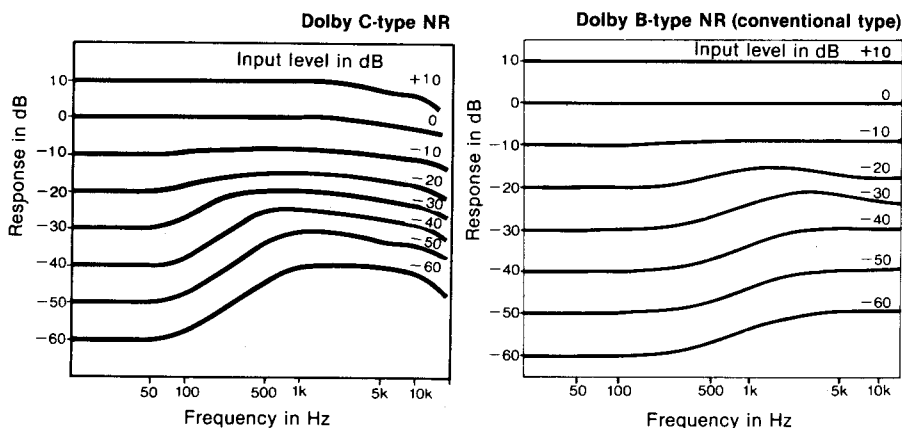

Fig. 2 Noise improvement

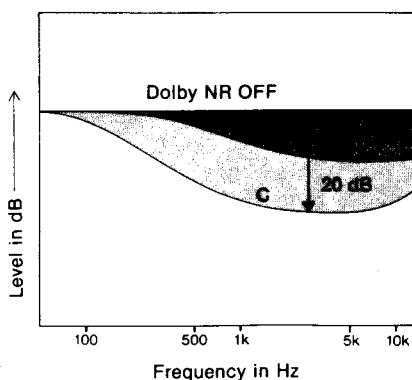
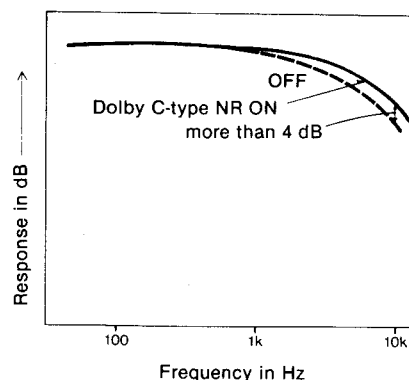

Fig. 3 Saturation level improvement



1-3. TROUBLE CHECKS

The following trouble checks will help you correct the most common problems encountered with a tape deck. Should any problem persist after you have made these checks, consult your nearest Sony service facility.

Before proceeding with these trouble checks, first check these basic points:

- The power cord must be firmly connected.
- Amplifier connections must be firmly made.
- Heads, capstan and pinch roller should be clean.
- The amplifier controls and switches should be set correctly.

FUNCTION BUTTONS AND TAPE TRANSPORT PROBLEMS

The function buttons do not activate right after the POWER switch is turned on.

- Logic-controlled function buttons operate approximately 4 seconds after the POWER switch is turned on.

Recording or playback begins as soon as the POWER switch is turned on.

- The TIMER switch is set at either REC or PLAY.

The ● button and the ► button do not activate.

- The cassette holder is not fully closed.

The ● button does not activate.

- No cassette in the holder.
- The tab has been removed from the cassette.

The automatic shut-off mechanism activates before the end of the tape.

- The tape is slack.
- This situation may also be caused by a deformed cassette shell.

Tape transport noise seems excessively loud in rewind or fast-forward mode.

- This situation depends upon the cassette used and not a problem.

RECORDING AND PLAYBACK PROBLEMS

Recording or playback cannot be made or there is a decrease in sound level.

- Contamination or magnetic build-up on the record/playback head.
- Improper connection.
- Improper setting of the amplifier controls.

The AMS does not operate.

- The blank space between the selections is less than four seconds long.
- Severe noise or hum exists in the blank spaces.
- A recorded selection is less than 20 seconds long.

Excessive wow or flutter or drop out

- Contamination of the capstan or pinch roller.

Incomplete erasure

- Contamination of the erase head.

Increase of noise or erasure of high frequencies

- Magnetic build-up on the head.

Unbalanced tone in higher frequencies

- Improper setting of the DOLBY NR switch. When playing back, set the switch to the same position used in recording.
- Improper setting of the TAPE SELECT switch. Depress the TAPE SELECT switch when using a TYPE III (Fe-Cr) cassette or a TYPE IV (METAL) cassette which has no METAL tape detector slots.

HOWLING OR HUM NOISE

Oscillation occurs when trying to record from microphones.

- The microphone is too near the loudspeakers. Move the microphone away from the loudspeakers or reduce the amplifier volume.

Hum noise

- The tape deck is stacked on or under the amplifier. Relocate it.

**SECTION 2
DISASSEMBLY**

Note: Follow the disassembly procedure in the numerical order given.

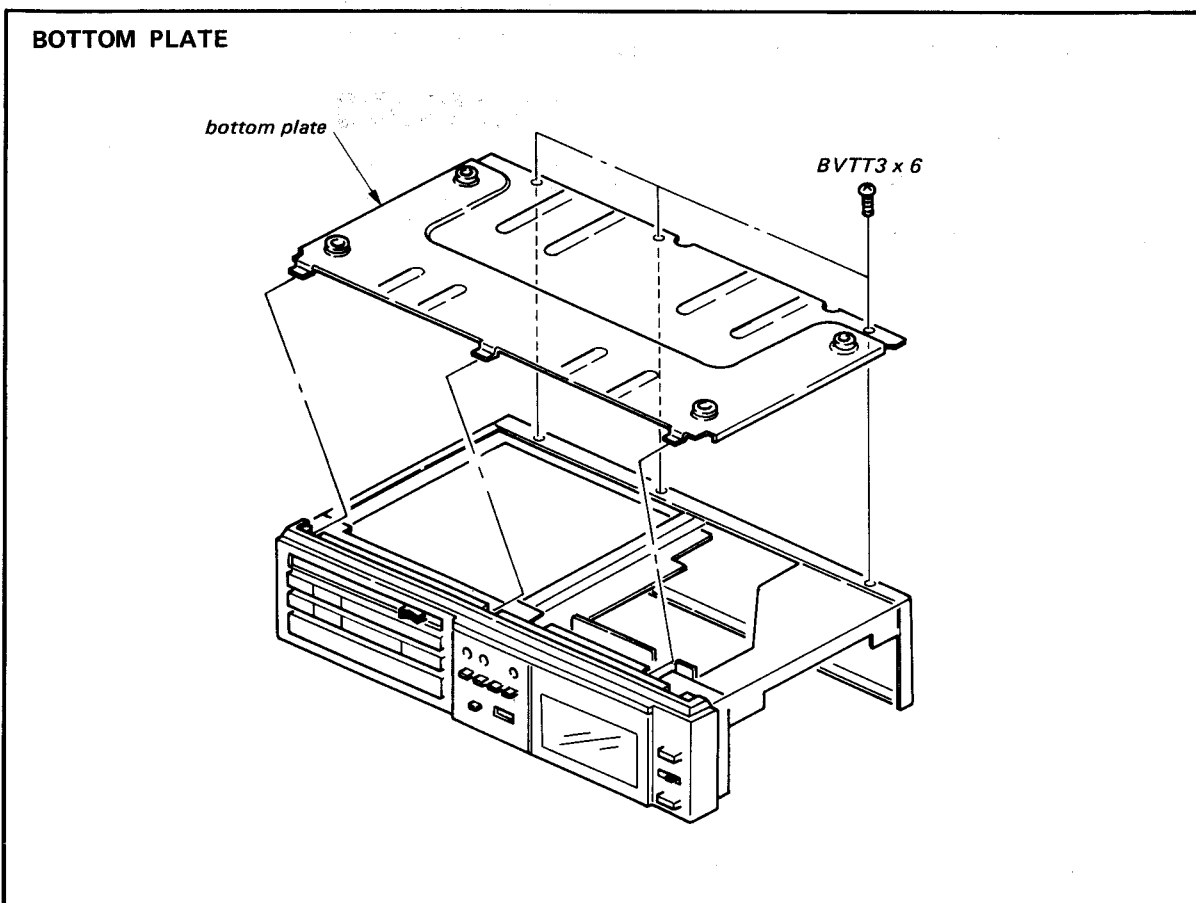
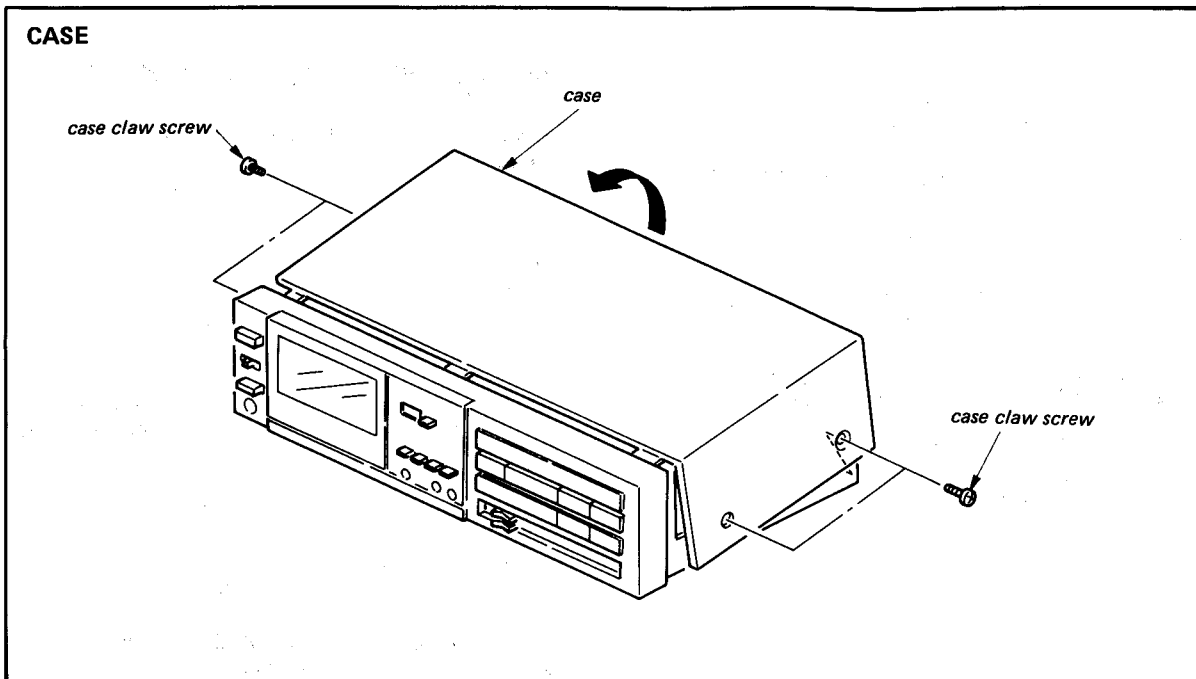

FRONT PANEL

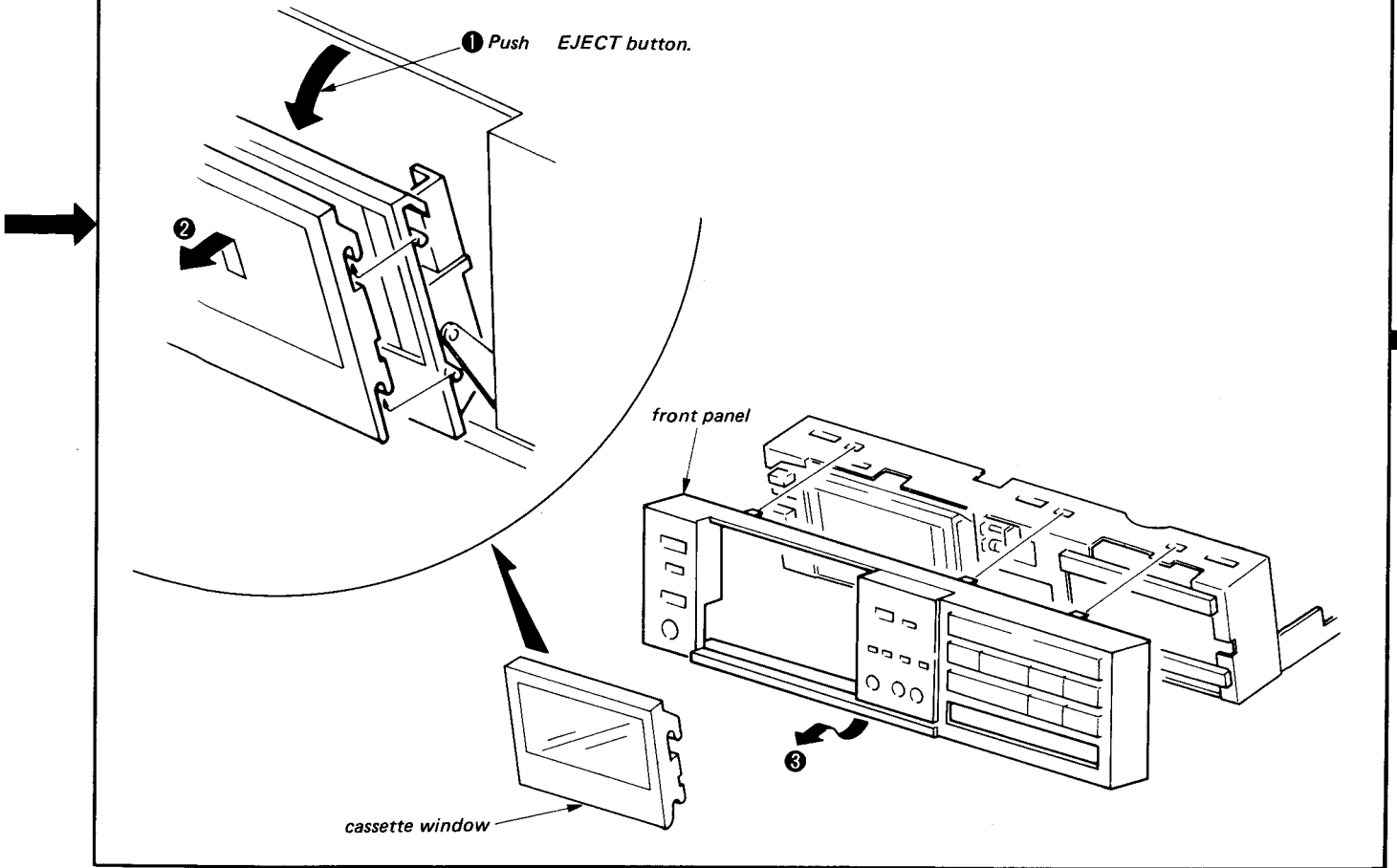

MD ORNAMENTAL PLATE

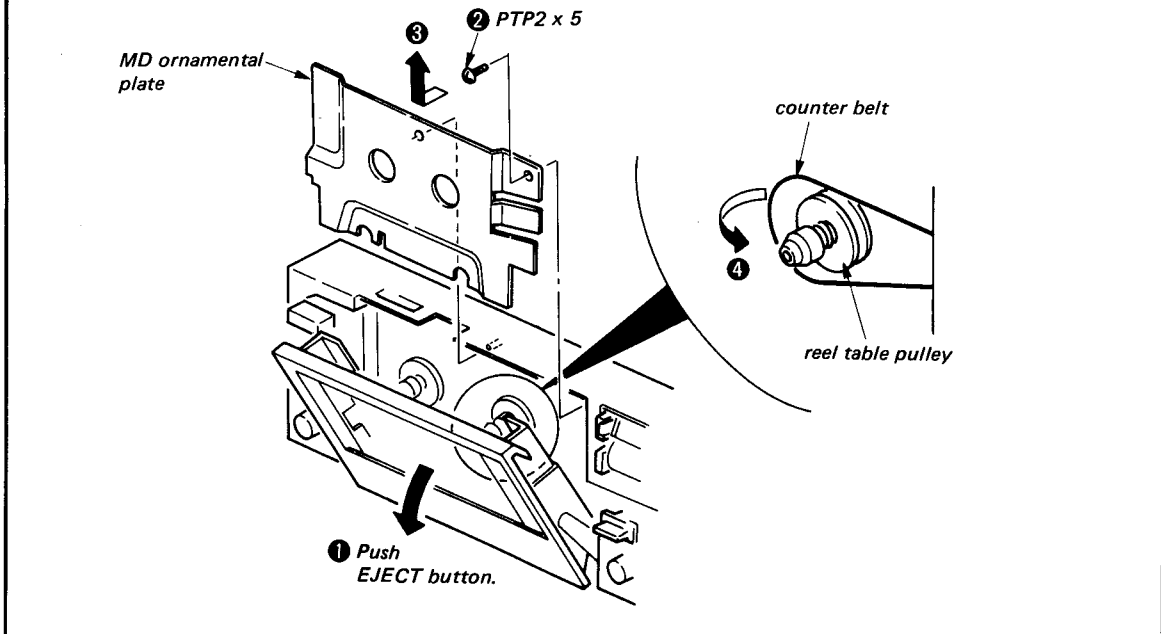

LED LEVEL METER UNIT, METER DRIVE BOARD

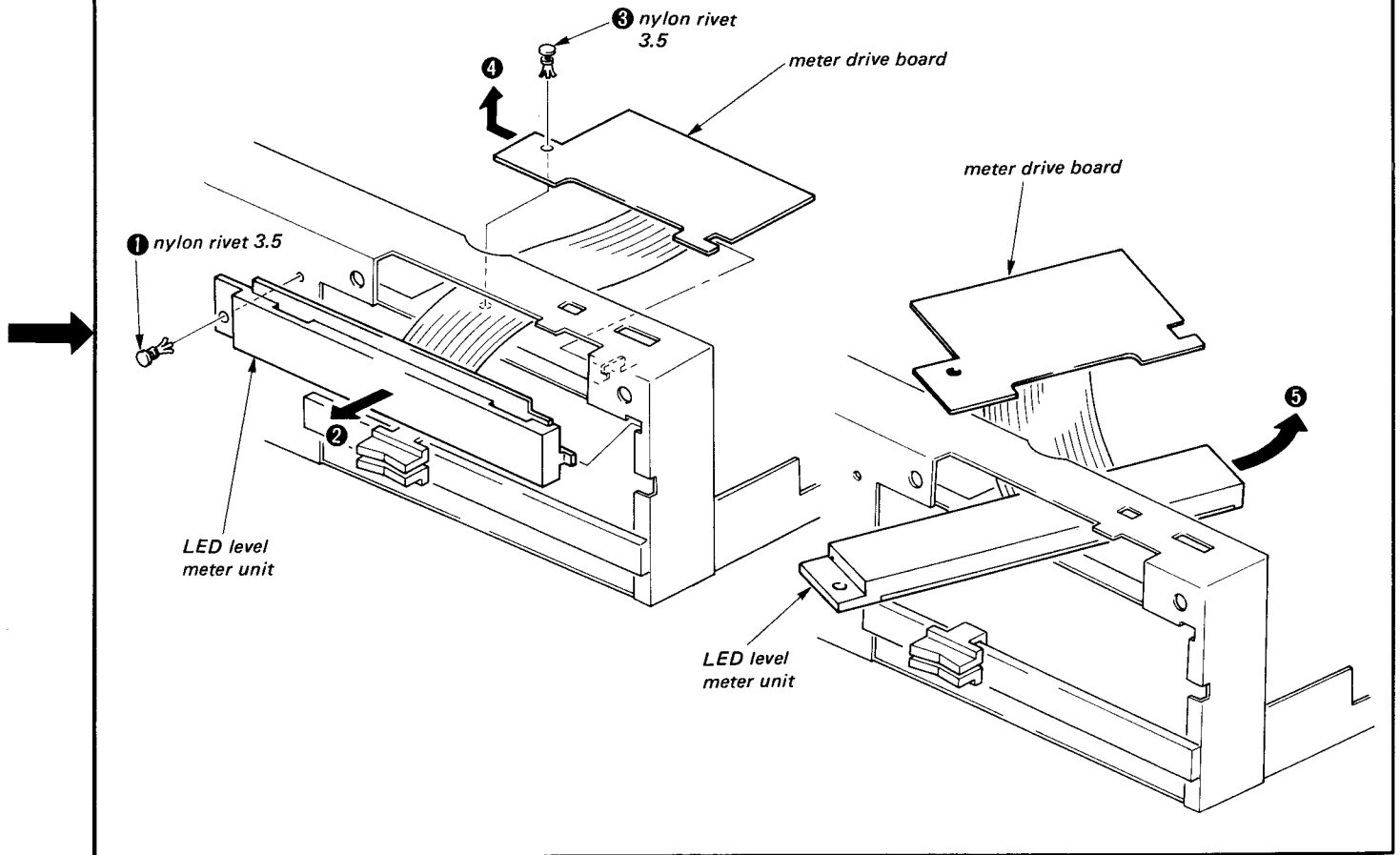

MECHANISM DECK

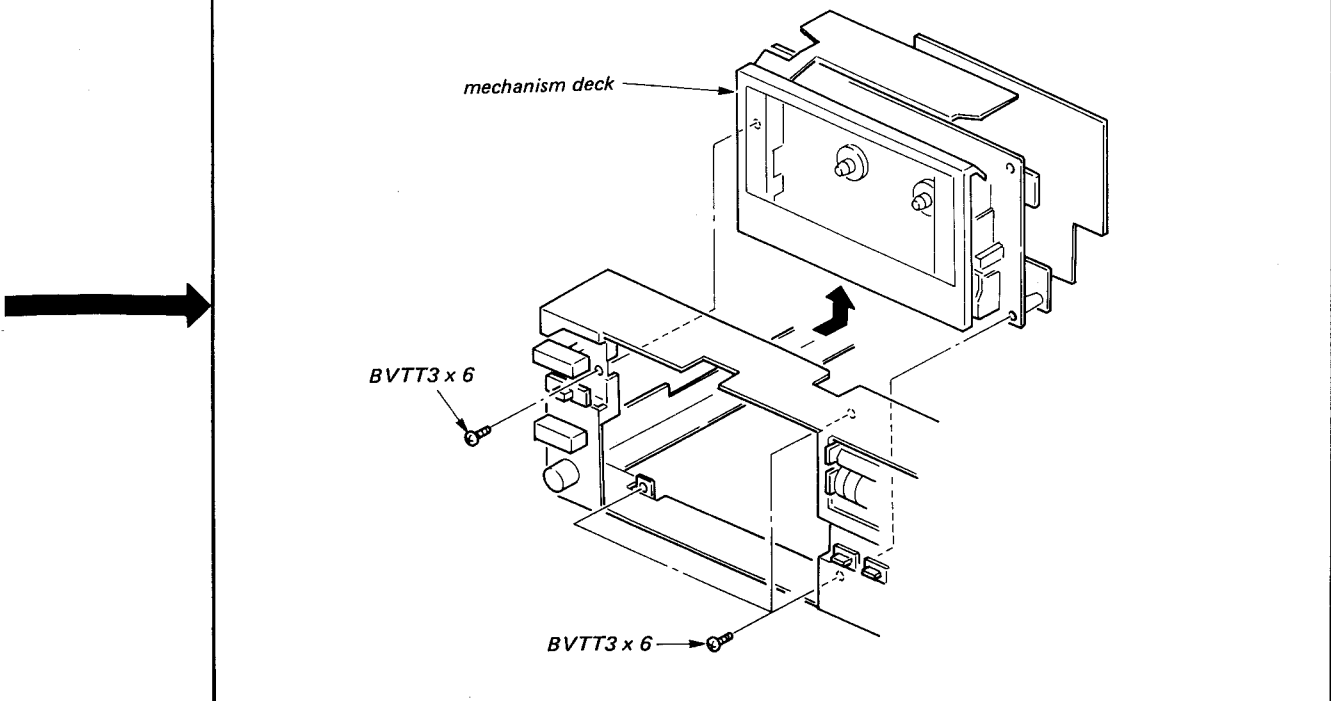

CASSETTE HOLDER, PISTON

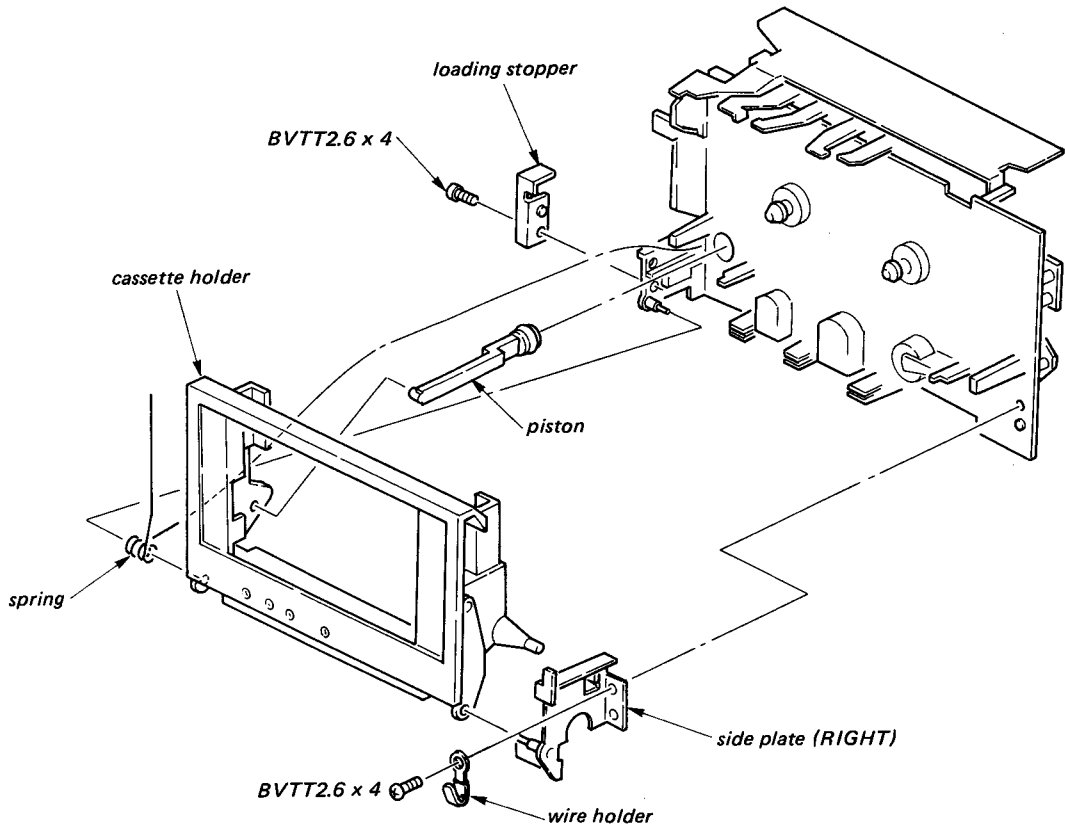

MECHANISM CONTROL BOARD, MICRO SWITCH BOARD

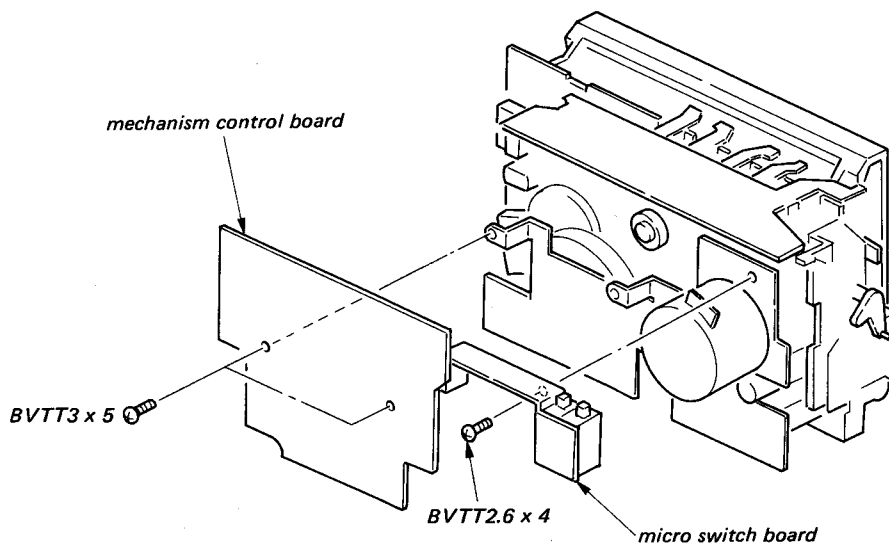

REC/PB HEAD, ERASE HEAD, PINCH ROLLER

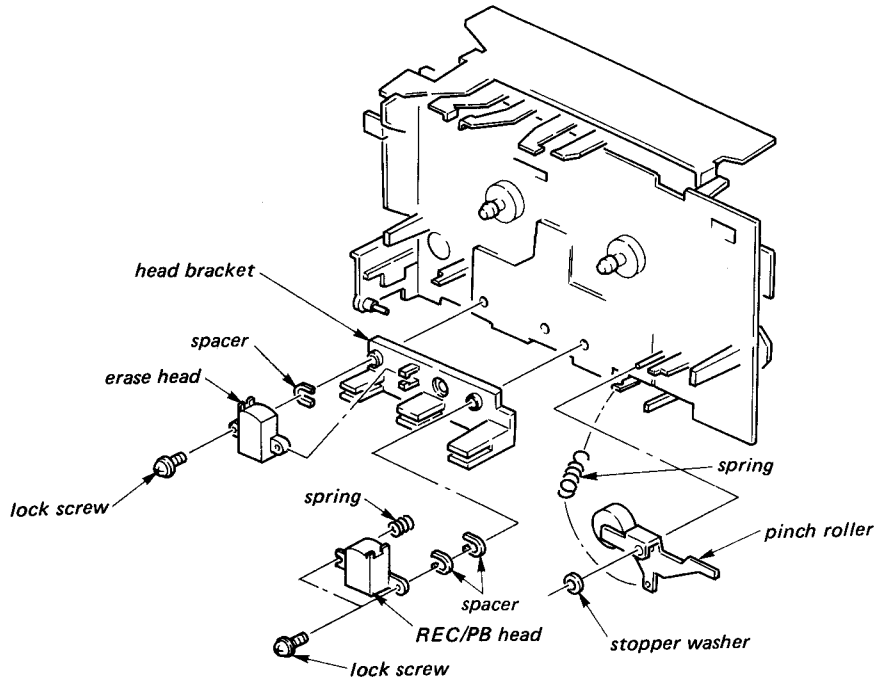

MOTOR, CAPSTAN BELT, FAST FORWARD BELT

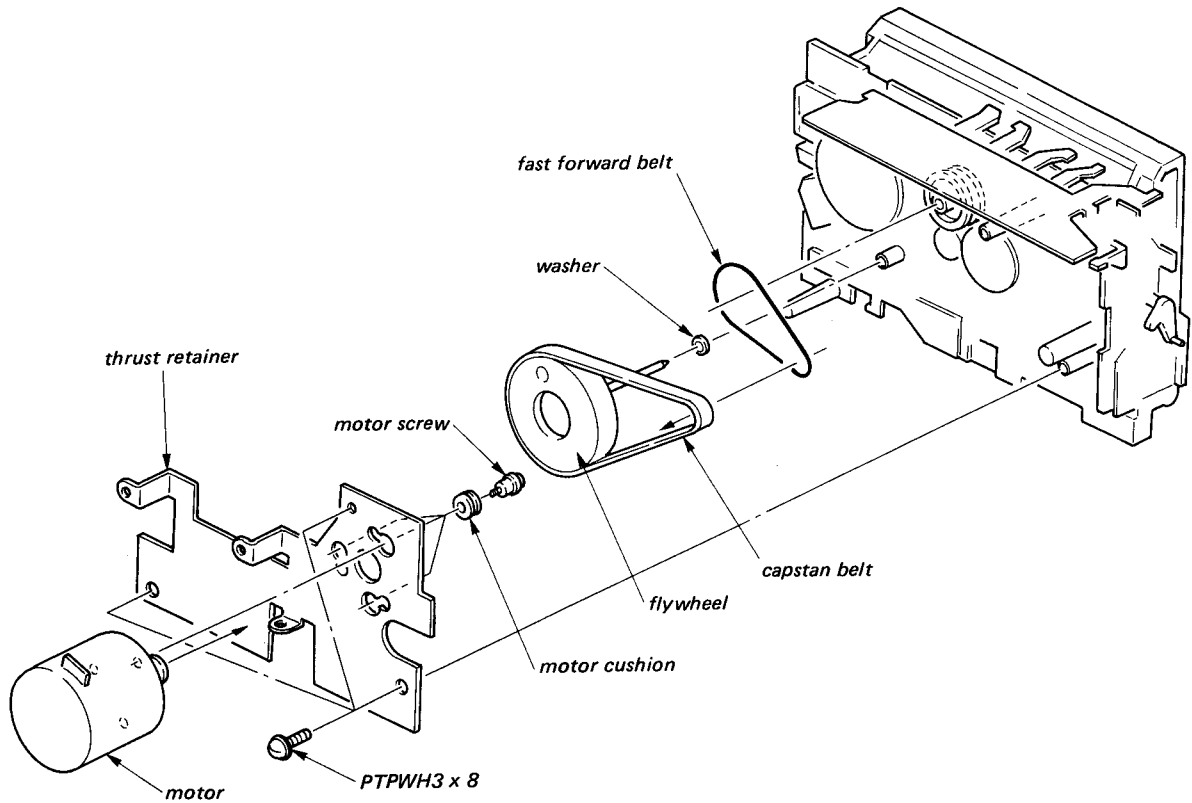

SECTION 3 ADJUSTMENTS

TC-FX44/FX44B

3-1. MECHANICAL ADJUSTMENTS

PRECAUTION

1. Clean the following parts with a denatured-alcohol-moistened swab:

record/playback head	pinch roller
erase head	rubber belts
capstan	idlers
2. Demagnetize the record/playback head with a head demagnetizer. (Do not bring the head demagnetizer close to the erase head.)

3. Do not use a magnetized screwdriver for the adjustments.
4. After the adjustments, apply suitable locking compound to the parts adjusted.
5. The adjustments should be performed with the rated power supply voltage unless otherwise noted.

Torque Measurement and Back Tension Torque Adjustment

Torque	Torque meter	Meter reading
Forward	CQ-102C	30 – 50 g·cm (0.42 – 0.69 oz·inch)
Back Tension		2.5 – 5 g·cm (0.035 – 0.07 oz·inch)
Fast Forward and Rewind	CQ-102B	80 – 150 g·cm (1.11 – 2.08 oz·inch)

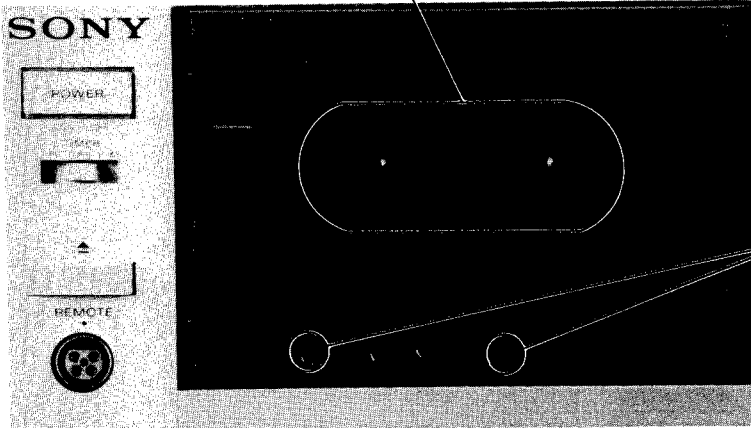

Head Height Adjustment Procedure:

1. Prepare an adjustment cassette as shown below.

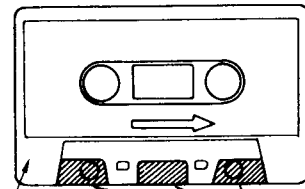

*C-120
tape cassette*

*Cut out hatched
portions.*

2. In playback mode and viewing from the front, adjust the head heights to eliminate tape curl and tape twist at the portions shown by the arrows.

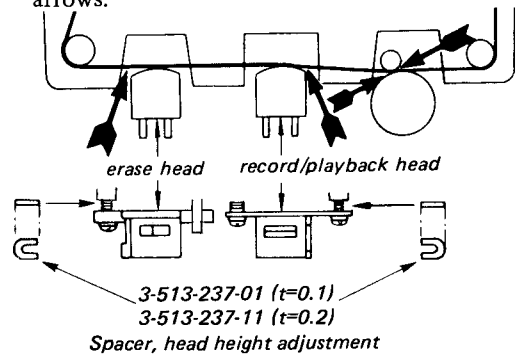

Soft Eject Adjustment

Procedure:

1. Insert a tape cassette.
2. Make sure that the cassette-lid opening time is 0.4 – 2.5 seconds when the EJECT button is pushed.
3. If the specification is not met, turn the adjustment screw.

opening time	turning direction
slow	clockwise
fast	counterclockwise

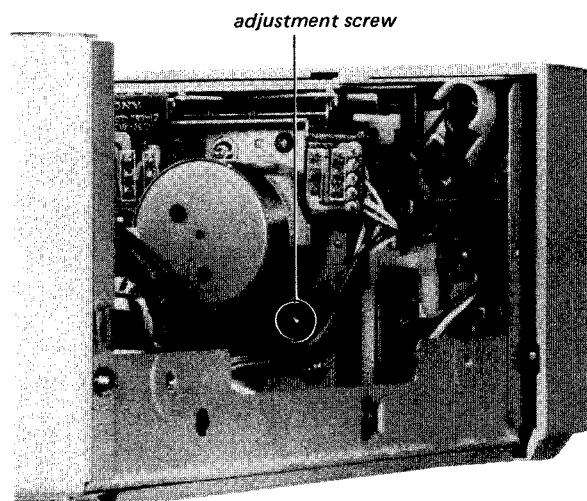

3-2. ELECTRICAL ADJUSTMENTS

Note: The adjustment should be performed in the order given in this service manual. The adjustments should be performed for both L-CH and R-CH.

- Set the TAPE SELECT switches according to the tape as follows.

Tape	TAPE SELECT switch	LED indication
CS-15	AUTO	I : NORM
CS-25	AUTO	II : CrO ₂
CS-30	Fe-Cr (METAL)	III : Fe-Cr
CS-40	AUTO or Fe-Cr (METAL)	IV : METAL

- Switches and controls should be set as follows unless otherwise specified.

DOLBY NR switch: OFF
 TAPE SELECT switch: AUTO (I : NORM)
 TIMER switch: OFF

- Standard Record:

Deliver the standard input signal level to the input jack and set the REC LEVEL control to obtain the standard output signal level.

Standard Input Level

	MIC	LINE IN
source impedance	300Ω	10kΩ
input level	0.77mV (-60dB)	0.25V (-10dB)

Standard Output Level

	LINE OUT	HEAD-PHONES
load impedance	47kΩ	8Ω
output level	0.44V (-5dB)	31mV (-28dB)

Tape Speed Adjustment

Procedure:

Mode: playback

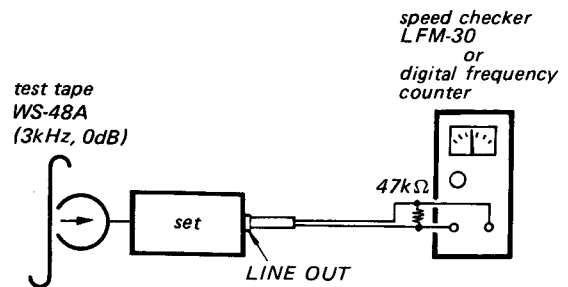

Specification:

Speed checker	Digital frequency counter
-1 to +1 %	2970 - 3030 Hz

Frequency difference between the beginning and the end of the tape should be within 1% (30Hz).

Adjustment Location:

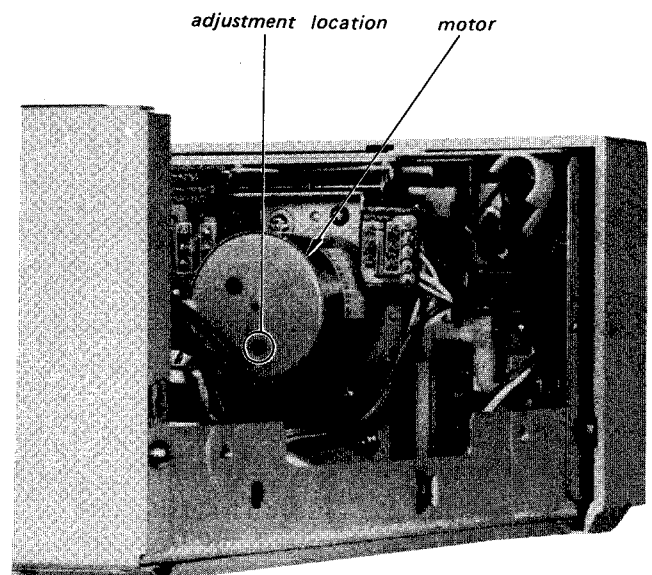

Record/playback Head Azimuth Adjustment

Procedure:
1. Mode: playback

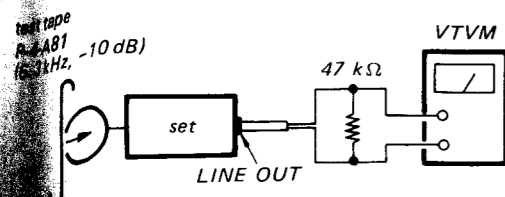

Turn the adjustment screw for the maximum output levels. If these levels do not match, turn the adjustment screw until both of output levels match together within 0.5 dB.

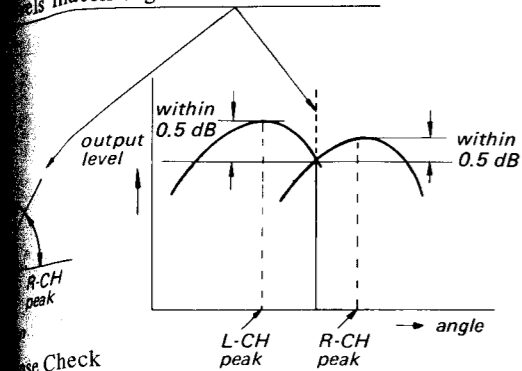

Check
Mode: playback

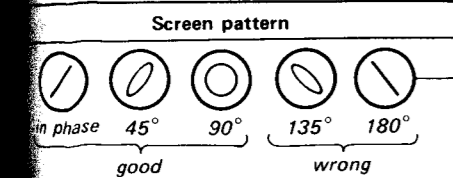
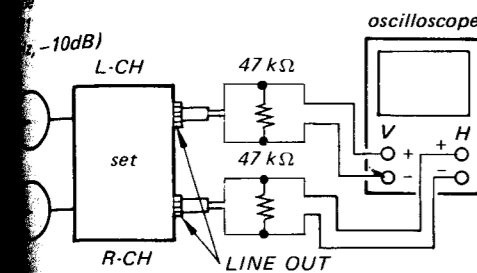

Adjustment Location:

adjustment screw

Playback Level Adjustment

Procedure:

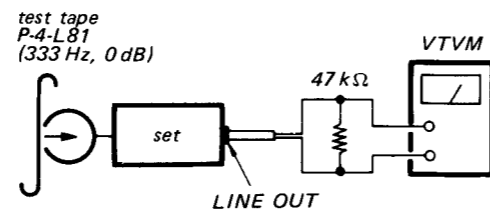

Specification:

LINE OUT level: 0.52 – 0.58V
(–3.5 to –2.5dB)

Level difference between channels:
less than 0.5dB

Check that the LINE OUT level does not change in playback mode while changing the mode from playback to stop several times.

Adjustment Location:

– REC/PB board –

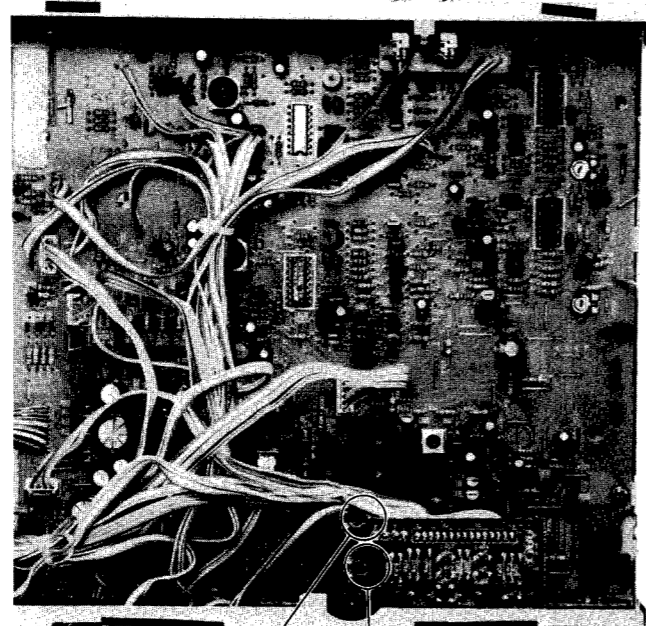

RV101 (L-CH) RV201 (R-CH)

Record Bias Adjustment

Setting:

REC LEVEL control: standard record
(See page 22)

Procedure:

1. Mode: record

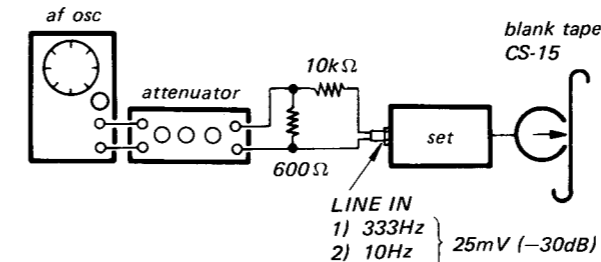

2. Mode: playback

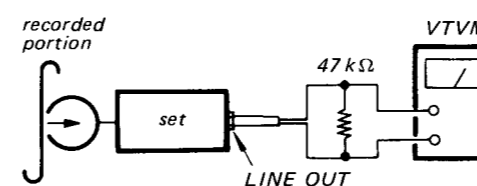

Adjust CT101 (L-CH) and CT201 (R-CH) so that the LINE OUT level of 10kHz signal is –0.5 to +0.5dB relative to that of 333Hz.

Note: After CT101 and CT201 are turned fully counterclockwise, adjust by turning clockwise.

Adjustment Location:

– REC/PB board –

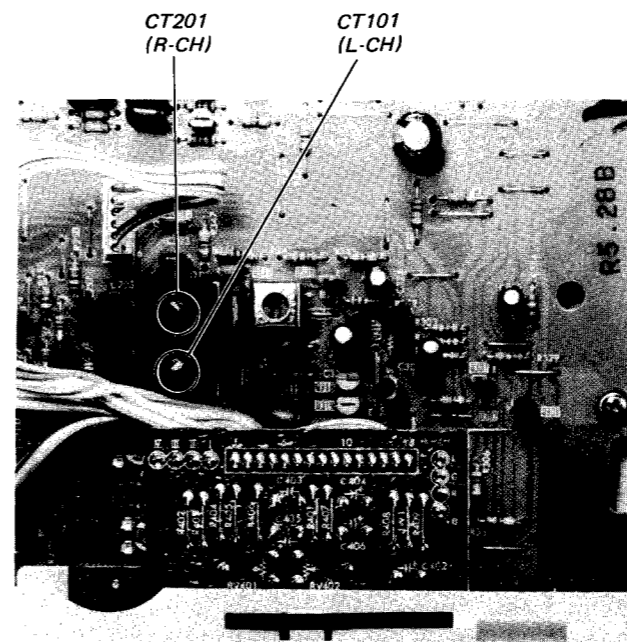

CT201 (R-CH) CT101 (L-CH)

Record Level Adjustment

Setting:

REC LEVEL control: standard record
(See page 22)

Procedure:

1. Mode: record

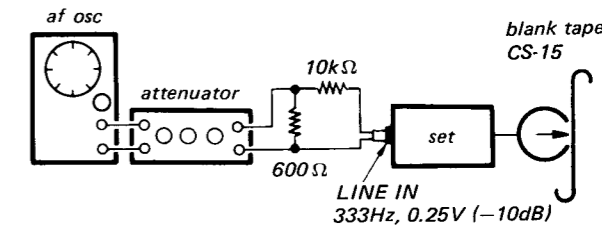

2. Mode: playback

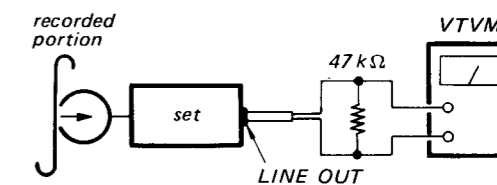

Specification:

LINE OUT level: 0.39 – 0.49V
(–6 to –4dB)

Adjustment Location:

– REC/PB board –

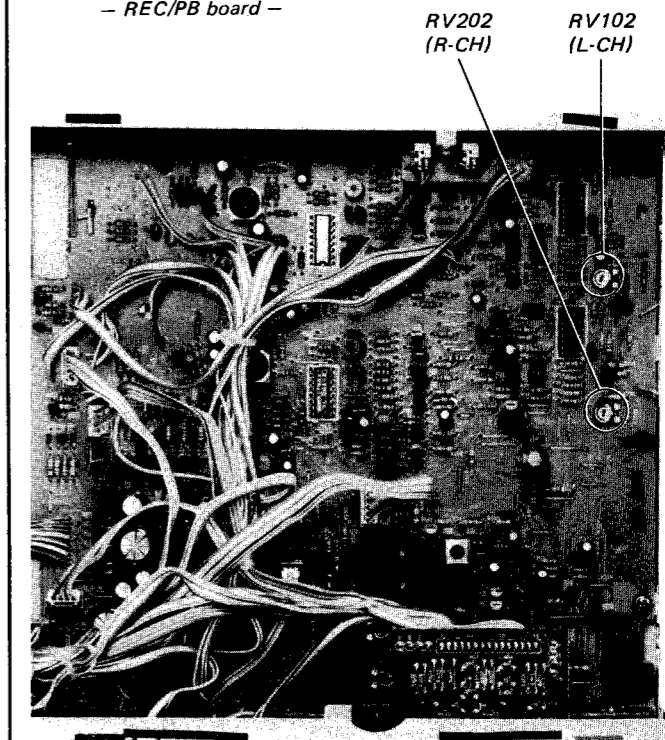

RV202 (R-CH) RV102 (L-CH)

Record/playback Head Azimuth Adjustment

Procedure:

1. Mode: playback

test tape
P-4-A81
(6.3 kHz, -10 dB)

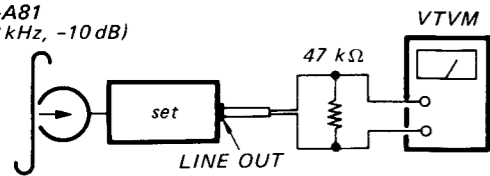

2. Turn the adjustment screw for the maximum output levels. If these levels do not match, turn the adjustment screw until both of output levels match together within 0.5 dB.

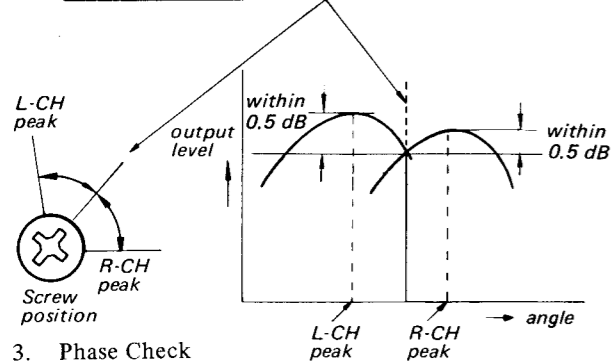

3. Phase Check
Mode: playback

test tape
P-4-A81
(6.3 kHz, -10 dB)

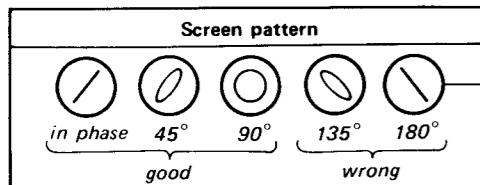
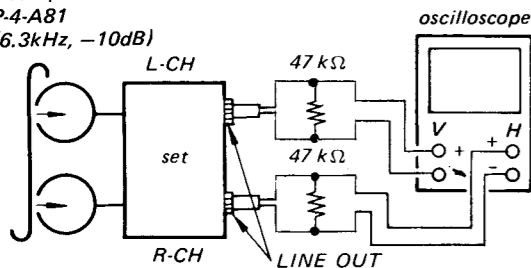

Adjustment Location:

adjustment screw

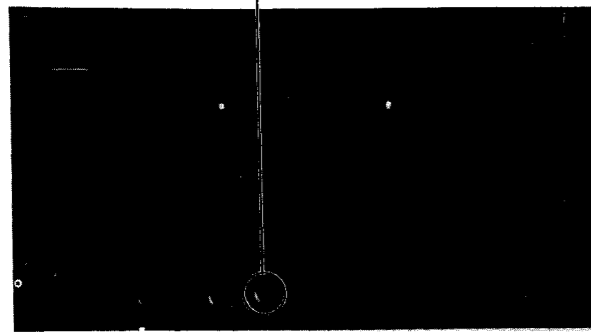

Playback Level Adjustment

Procedure:

test tape
P-4-L81
(333 Hz, 0 dB)

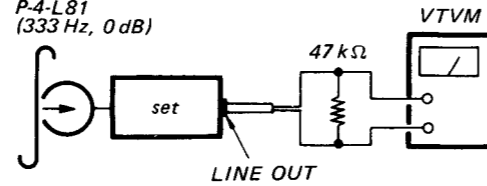

Specification:

LINE OUT level: 0.52 – 0.58V
(-3.5 to -2.5dB)

Level difference between channels:
less than 0.5dB

Check that the LINE OUT level does not change in playback mode while changing the mode from playback to stop several times.

Adjustment Location:

- REC/PB board -

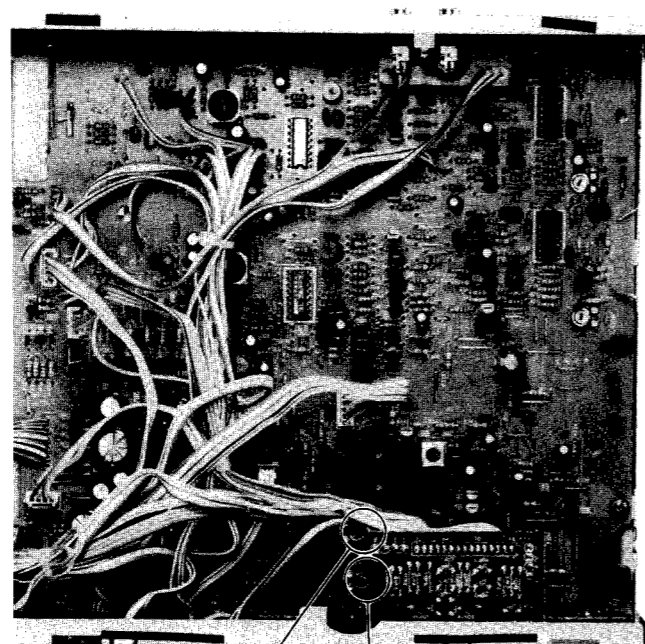

RV101 (L-CH) RV201 (R-CH)

Record Bias Adjustment

Setting:

REC LEVEL control: standard record
(See page 22)

Procedure:

1. Mode: record

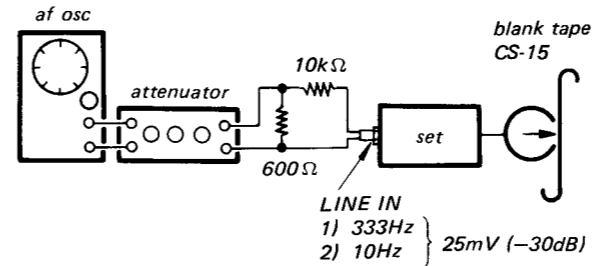

2. Mode: playback

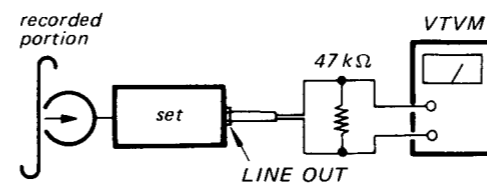

Adjust CT101 (L-CH) and CT201 (R-CH) so that the LINE OUT level of 10kHz signal is -0.5 to +0.5dB relative to that of 333Hz.

Note: After CT101 and CT201 are turned fully counterclockwise, adjust by turning clockwise.

Adjustment Location:

- REC/PB board -

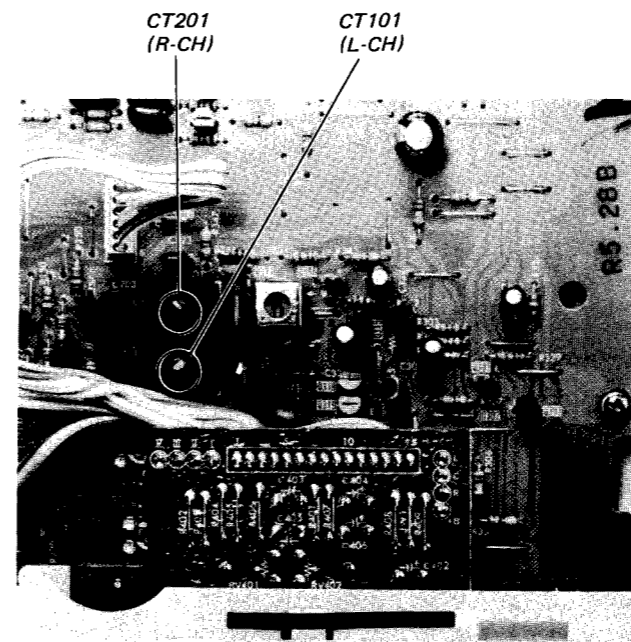

CT201 (R-CH) CT101 (L-CH)

Record Level Adjustment

Setting:

REC LEVEL control: standard record
(See page 22)

Procedure:

1. Mode: record

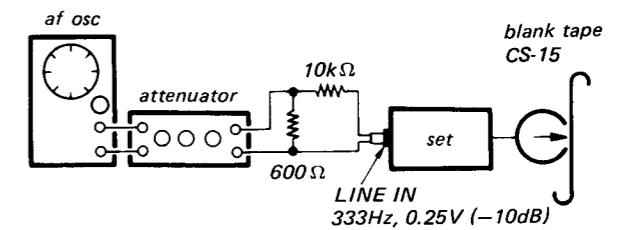

2. Mode: playback

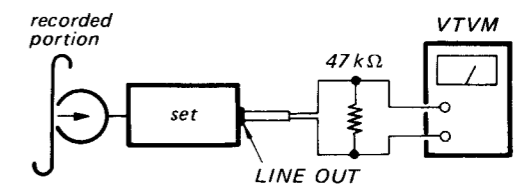

Specification:

LINE OUT level: 0.39 – 0.49V
(-6 to -4dB)

Adjustment Location:

- REC/PB board -

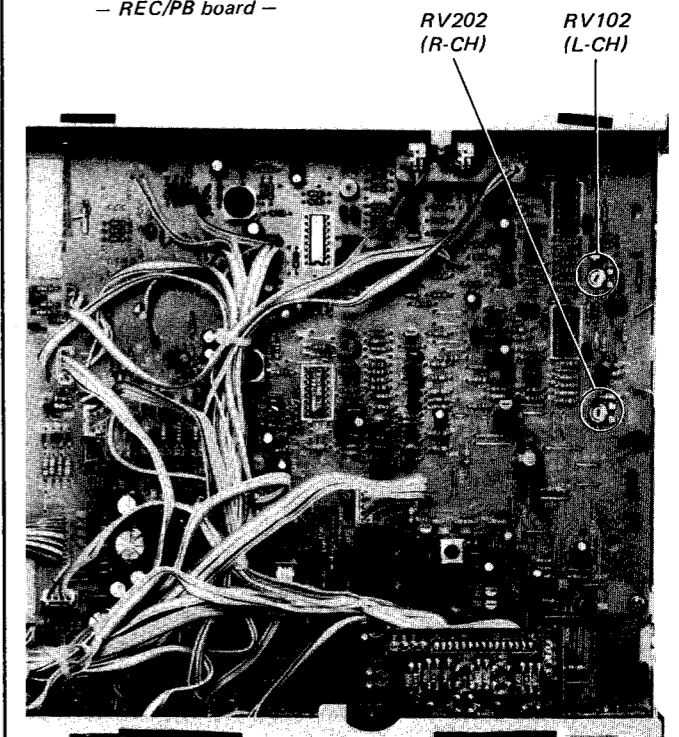

RV202 (R-CH) RV102 (L-CH)

Record Bias Adjustment

Setting:

REC LEVEL control: standard record
(See page 22)

Procedure:

1. Mode: record

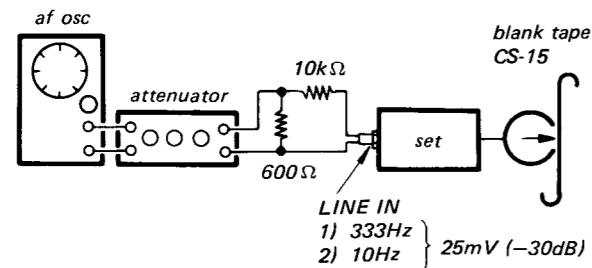

2. Mode: playback

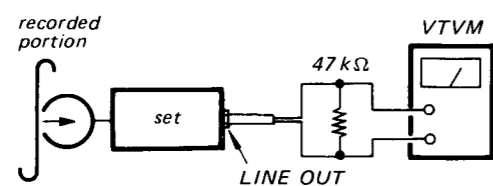

Adjust CT101 (L-CH) and CT201 (R-CH) so that the LINE OUT level of 10kHz signal is -0.5 to +0.5dB relative to that of 333Hz.

Note: After CT101 and CT201 are turned fully counterclockwise, adjust by turning clockwise.

Adjustment Location:

- REC/PB board -

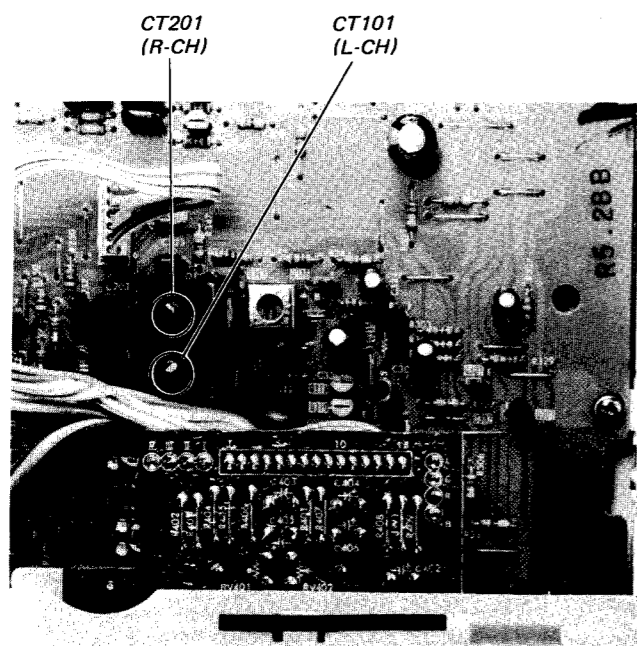

Record Level Adjustment

Setting:

REC LEVEL control: standard record
(See page 22)

Procedure:

1. Mode: record

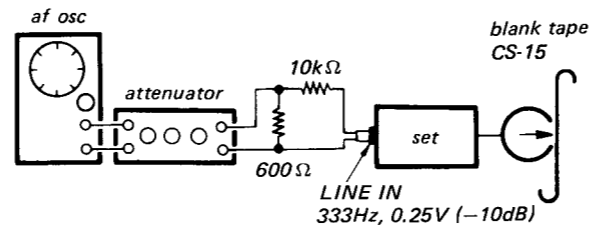

2. Mode: playback

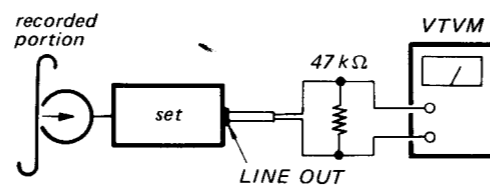

Specification:

LINE OUT level: 0.39 - 0.49V
(-6 to -4dB)

Adjustment Location:

- REC/PB board -

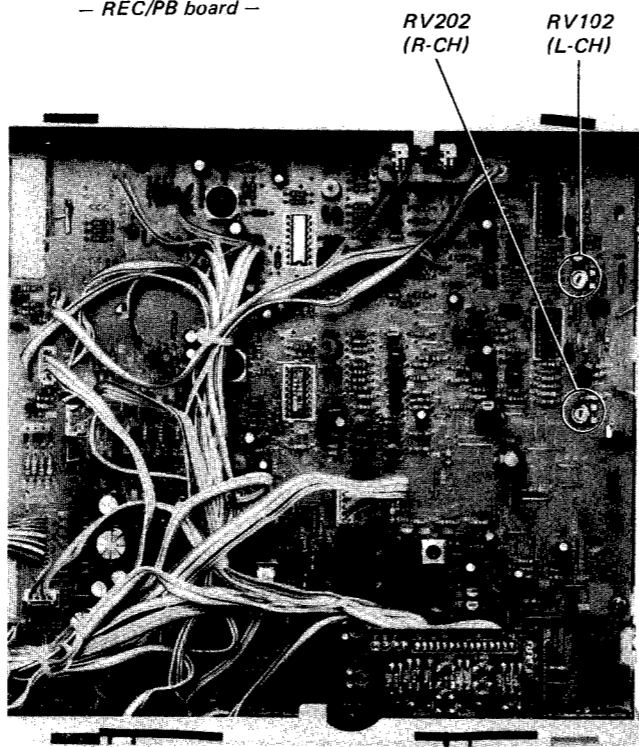

Peak Level Meter Calibration

Setting:

REC LEVEL control: standard record
(See page 22)

Procedure:

1. Mode: record

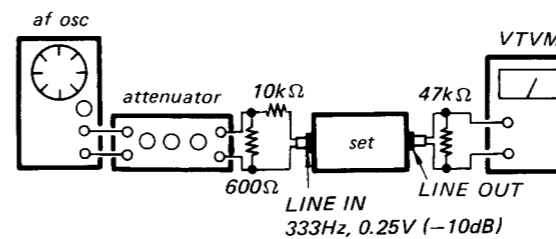

2. Set the REC LEVEL control so that the LINE OUT level is 0.44V (-5dB).
3. Set RV401 (L-CH), RV402 (R-CH) to the position just where when the forth LED from the right side turns off on the PEAK LEVEL meter.

4. Set the REC LEVEL control so that the LINE OUT level is 1.9V (+8dB).

Make sure that all the LEDs turn on.

Note: The adjustment should be started with the REC LEVEL control set to the maximum position.

Adjustment Location:

- meter drive board -

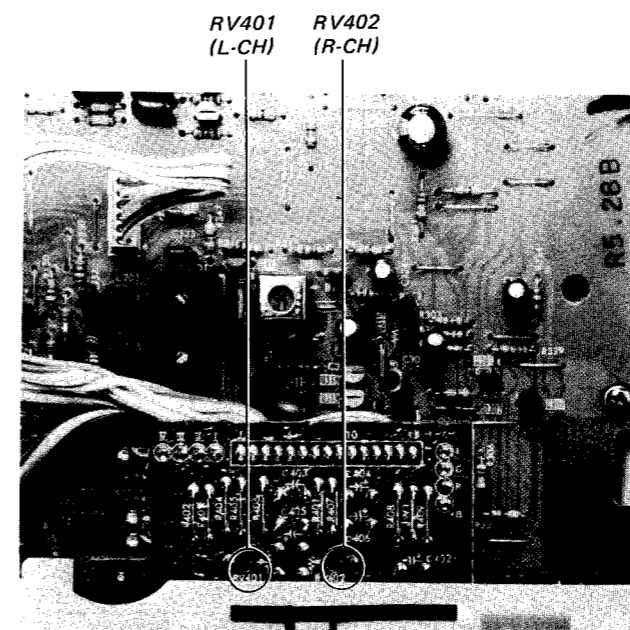

4-1. AUDIO AMP SECTION
MOUNTING DIAGRAM

— Conductor Side —

- Refer to page 32 for semiconductor lead layouts.

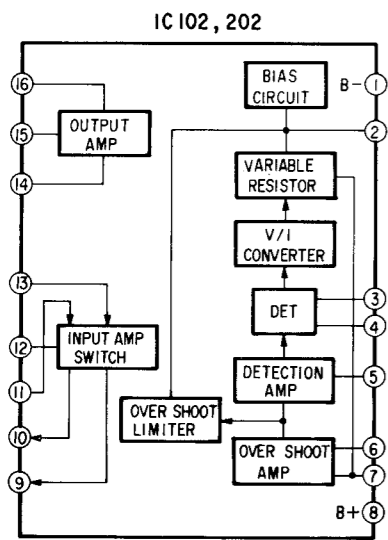
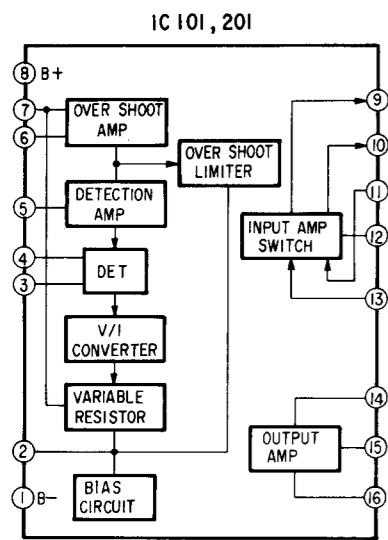

Note:

- Color code of sleeving over the end of the jacket.

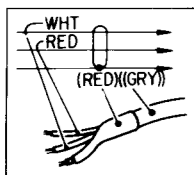

- ○ : parts extracted from the component side.
- ● : parts extracted from the conductor side.
- ■ : part mounted on the conductor side.
- □ : indicates side identified with part number.
- ▨ : B + pattern

- ——— : signal path
- ——— : L-CH signal path
- ——— : R-CH signal path

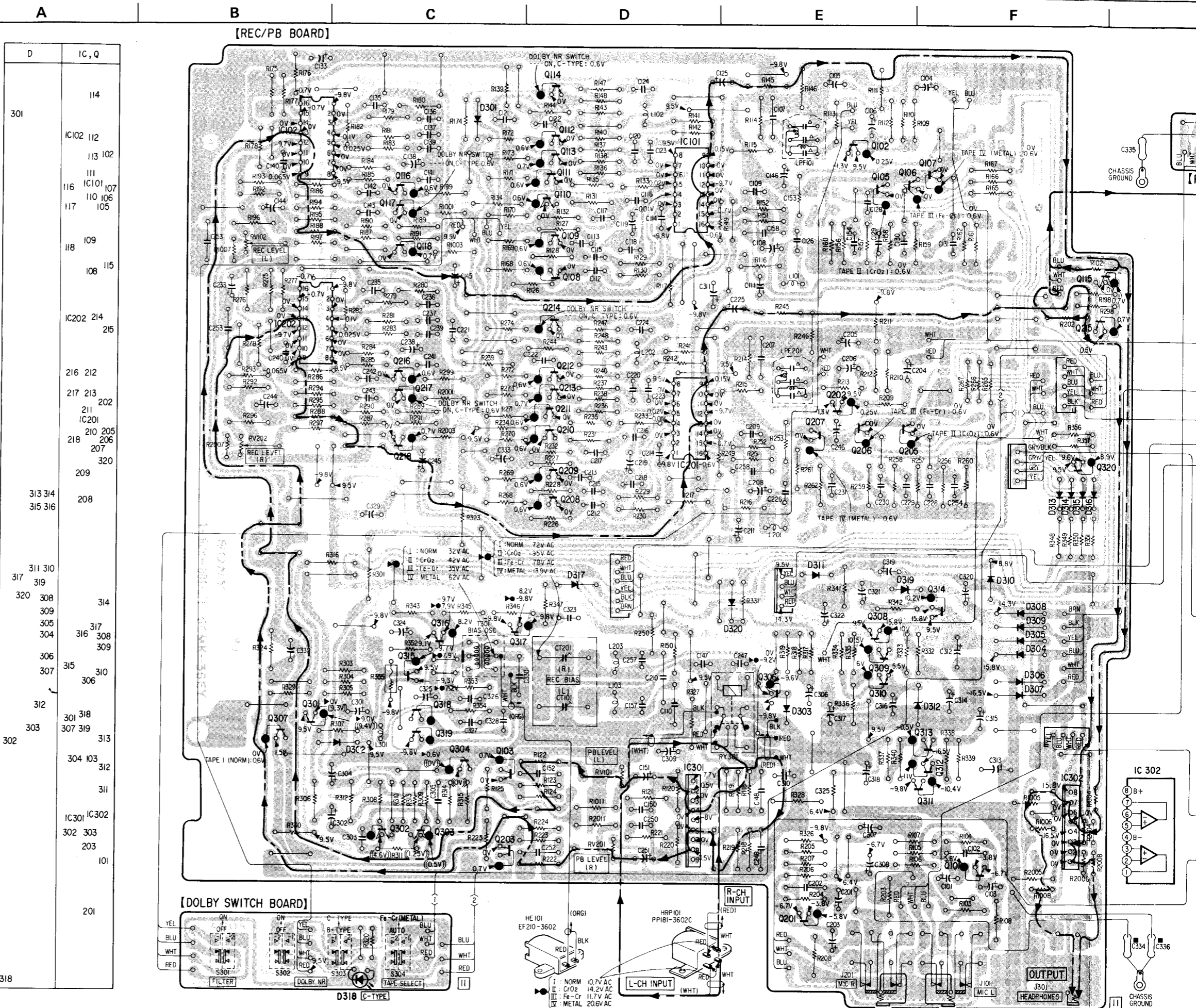

TC-FX44/FX44B TC-FX44/FX44B

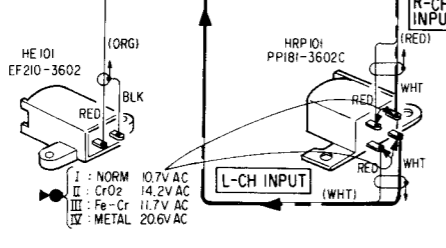
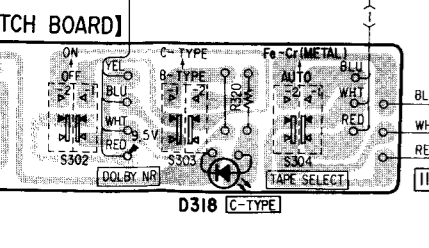
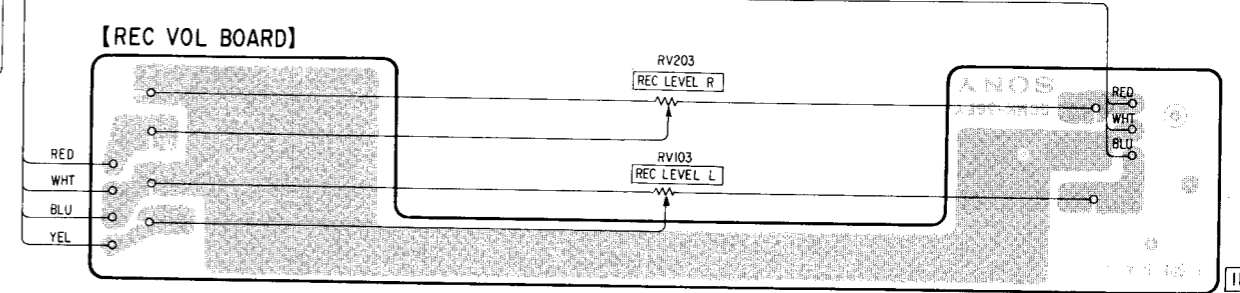
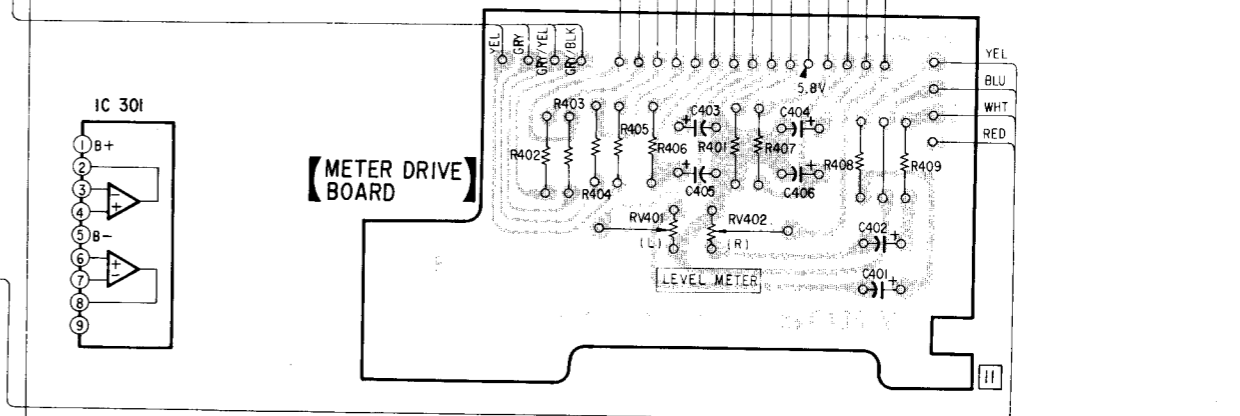
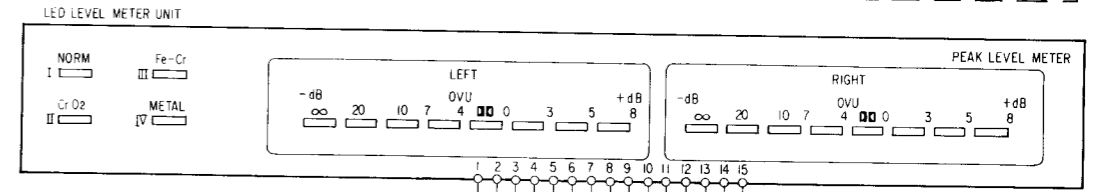
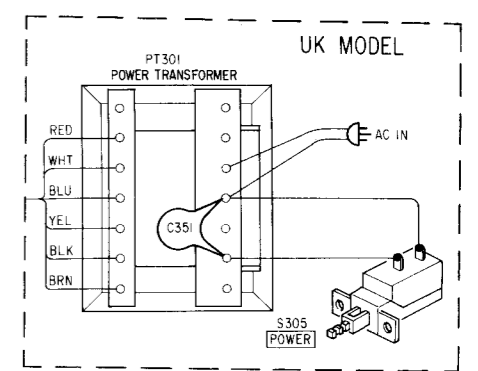
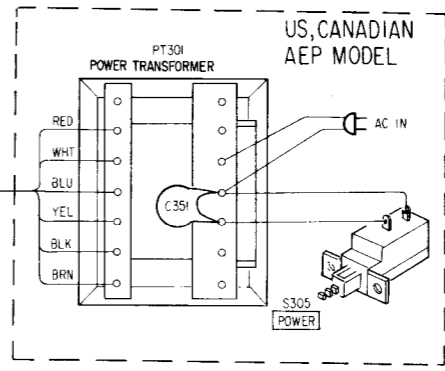
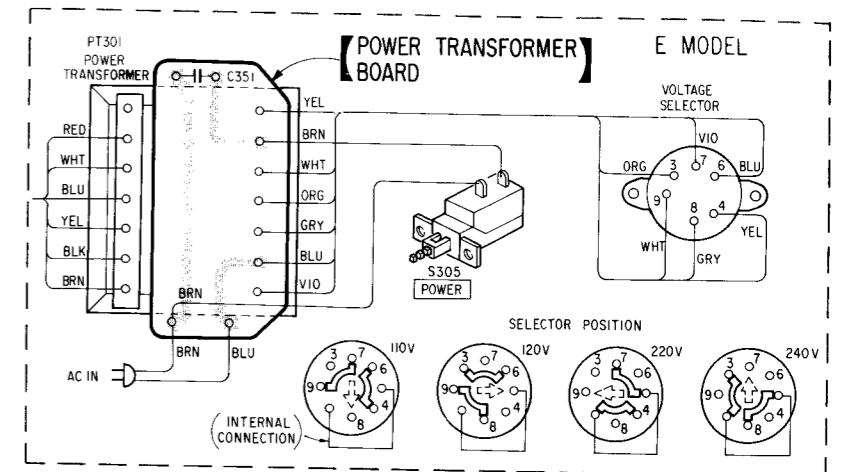
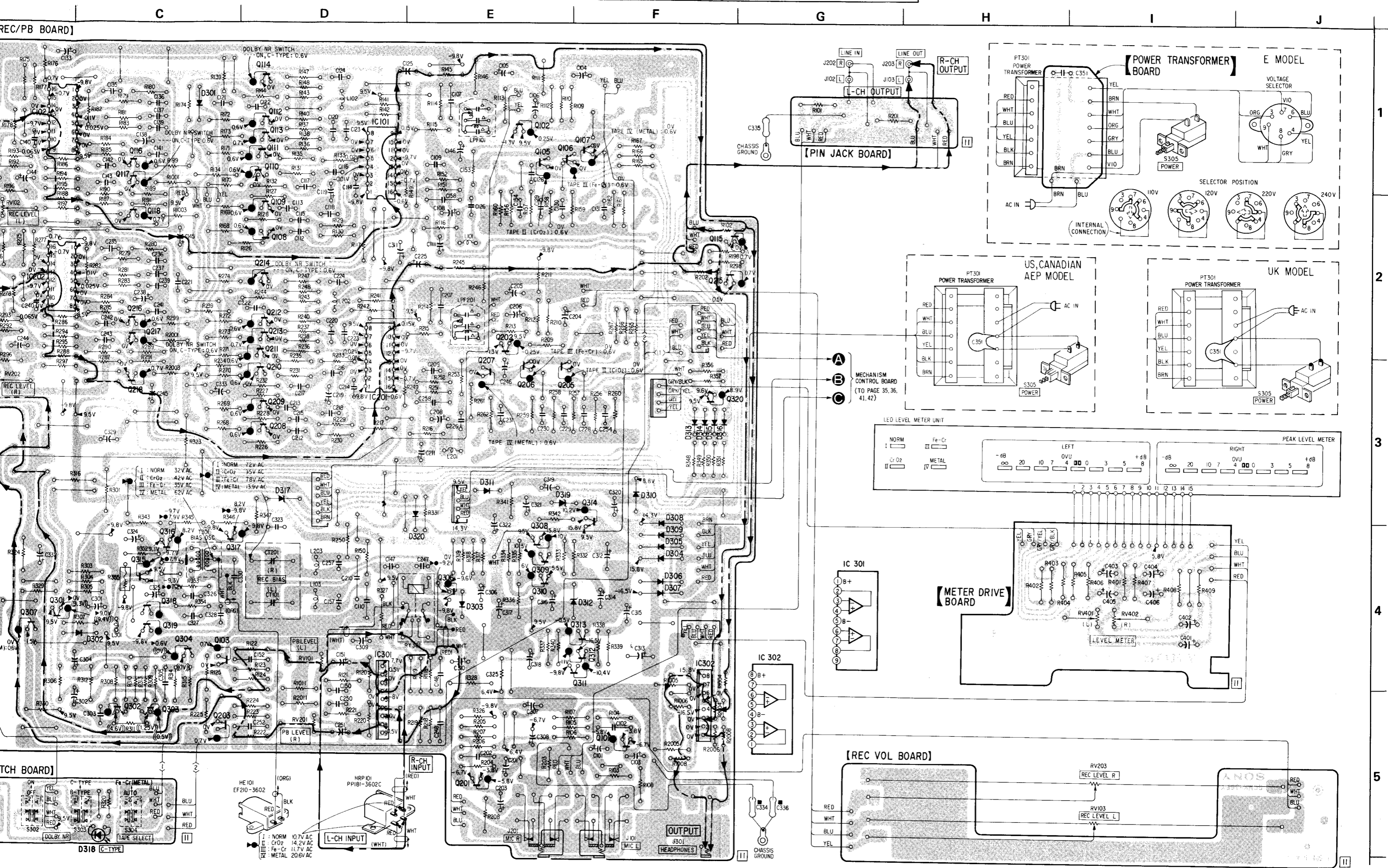

A
B
C

MECHANISM CONTROL BOARD (TO PAGE 35, 36, 41, 42)

1
2
3
4
5

4-2. AUDIO AMP SECTION
SCHEMATIC DIAGRAM

TC-FX44/FX44B TC-FX44/FX44B

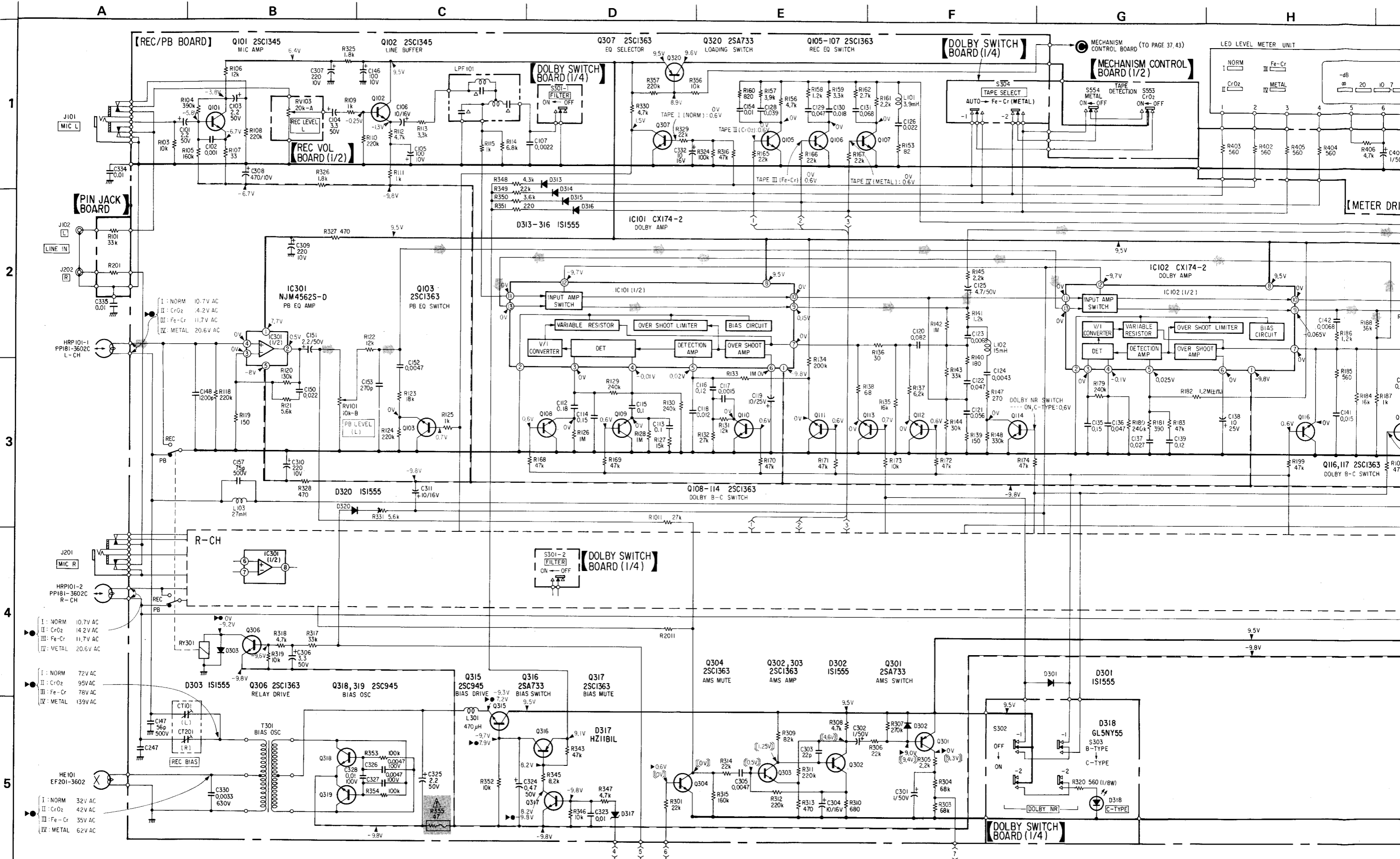

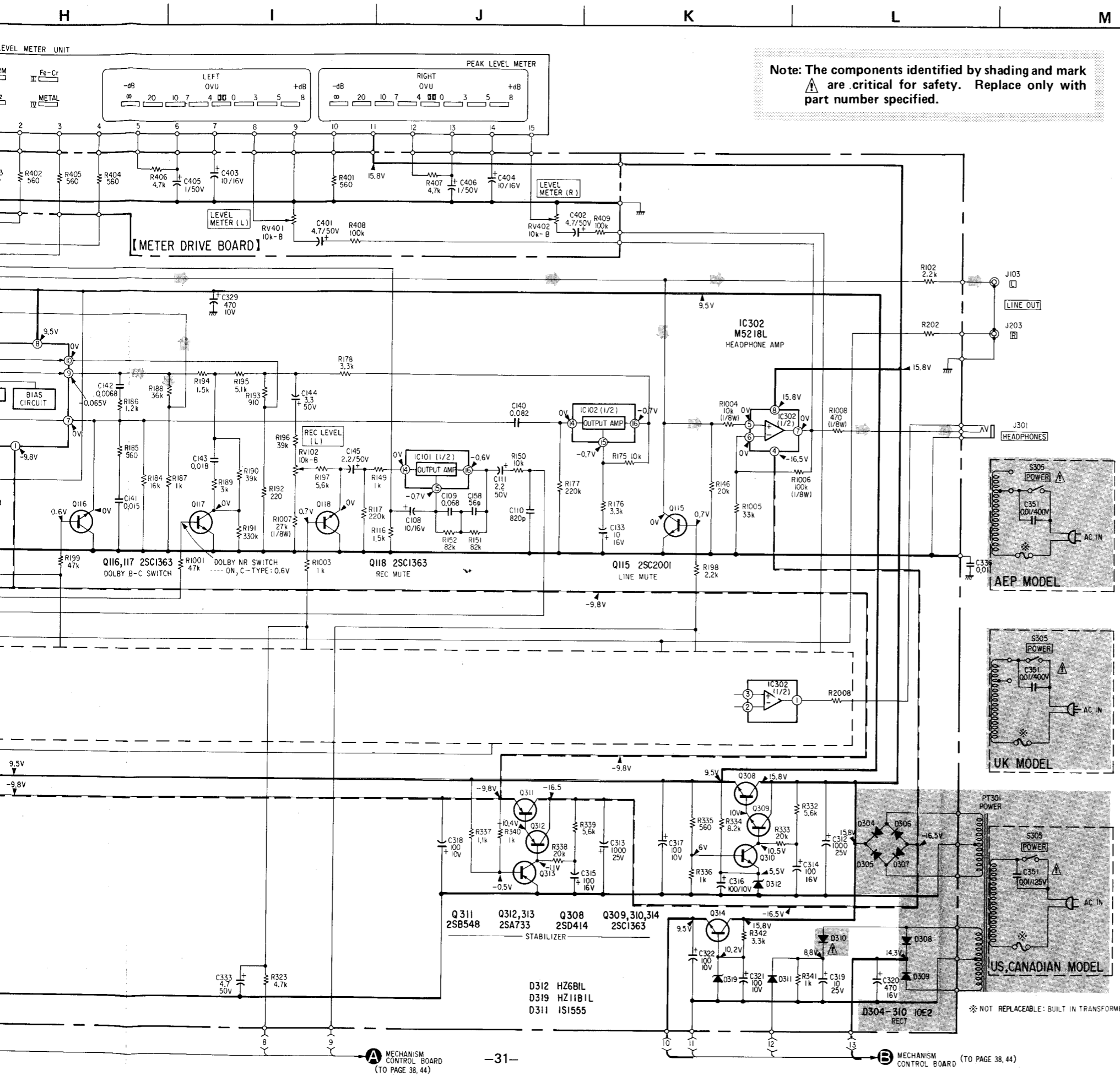

Note: The components identified by shading and mark are critical for safety. Replace only with part number specified.

Note: Les composants identifiés par une trame et une marque sont critiques pour la sécurité. Ne les remplacer que par une pièce portant le numéro spécifié.

- Note:**
- Components for right channel have same values as for left channel. Reference numbers are coded from 201, 2001.
 - All capacitors are in μF unless otherwise noted. pF : $\mu\mu\text{F}$ 50VV or less are not indicated except for electrolytics and tantalums.
 - All resistors are in ohms, $\frac{1}{4}\text{W}$ unless otherwise noted. $\text{k}\Omega$: 1000 Ω , $\text{M}\Omega$: 1000 $\text{k}\Omega$
 - : fusible resistor.
 - : internal component.
 - : adjustment for repair.
 - : B+ bus.
 - : B- bus.
 - Voltages are dc with respect to ground unless otherwise noted.
 - Readings are taken under the POWER switch to ON conditions with cassette installed.
 - no mark : stop
 - : playback
 - : record
 - : AMS operation
 - Voltage variations may be noted due to normal production tolerances.
 - AC voltage readings in the bias oscillator with a VTVM.
 - : signal path

Note: Voltages are measured with a VOM (50k Ω /V).

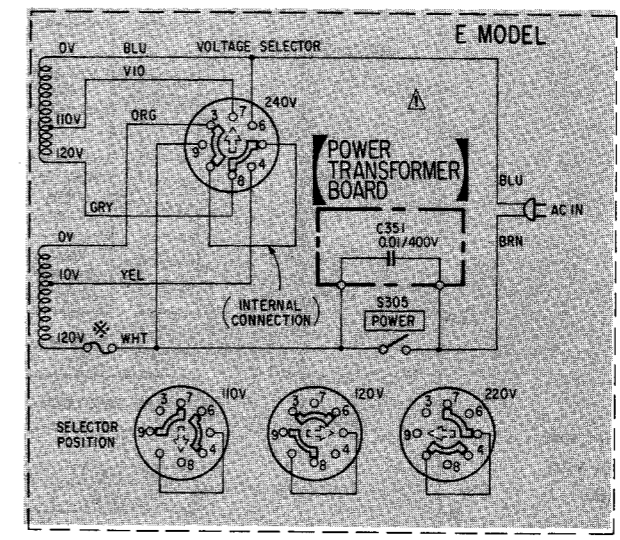
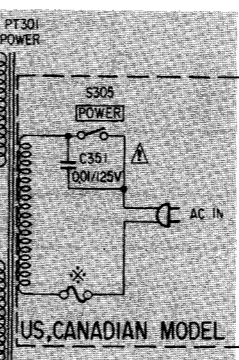
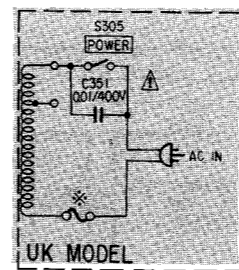
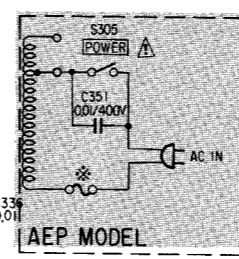

1
2
3
4
5

<p>CX174-2 CX174A</p> <p>(Top view)</p>
<p>M5218L</p>
<p>NJM4562S-D</p>
<p>2SA733 2SC1363 2SC945 2SC1364 2SC1345 2SC2001</p>
<p>2SA1027R</p>
<p>2SB548 2SD414</p> <p>letter side</p>
<p>1S1555 10E2 HZ6B1L HZ11B1L</p>
<p>GL5NY55</p>

4-3. MECHANISM CONTROL SECTION MOUNTING DIAGRAM (Former Model) — Conductor Side —

Semiconductor Lead Layouts

<p>NJM2903D TC4069UBP TC4073BP TC9310N001 μPC339C</p> <p>(Top view)</p>	<p>1SS133</p>
<p>NJM78M05A</p>	<p>SLR34PC5 SLR34URC5</p>
<p>2SA1175</p>	<p>SPI201</p>
<p>2SC945 2SC1364</p>	<p>AA3432S</p>

- Note:
- — : parts extracted from the component side.
 - — : parts extracted from the conductor side.
 - — : part mounted on the conductor side.
 - ▨ — : B + pattern

A B C D E F G

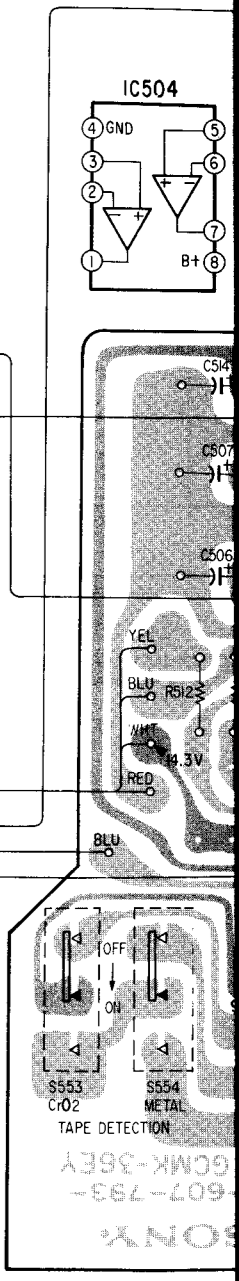
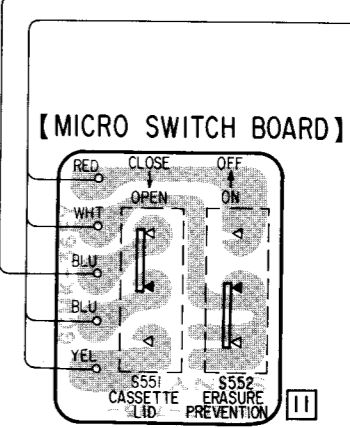
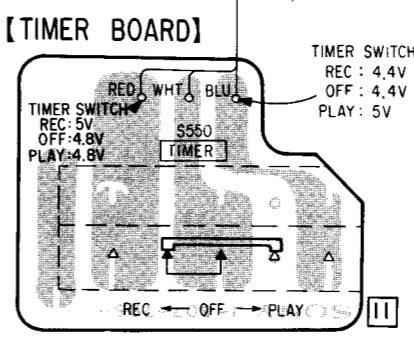
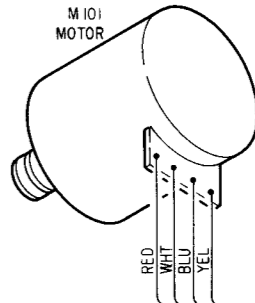
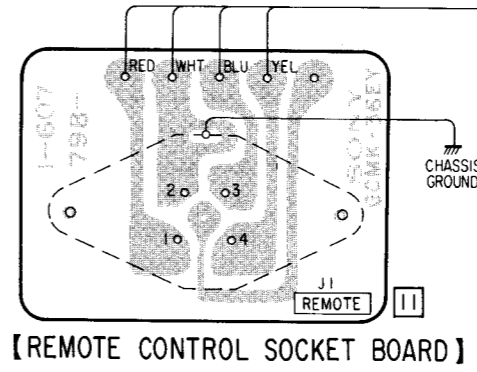
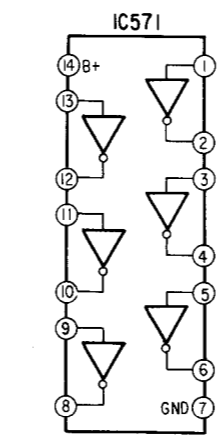
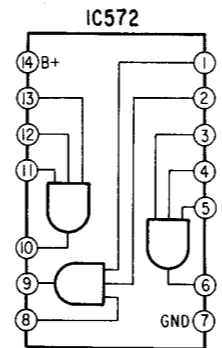
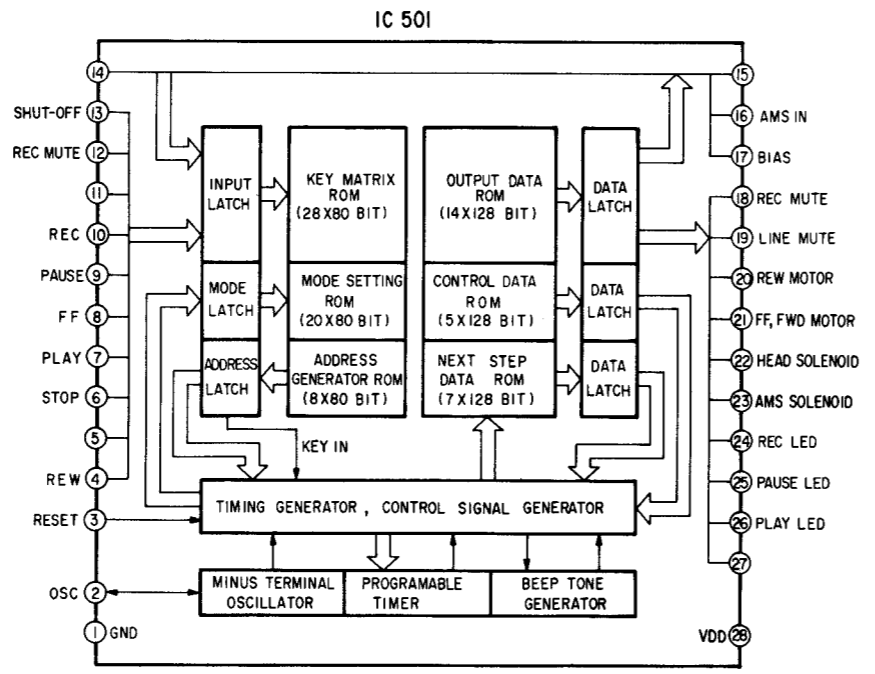
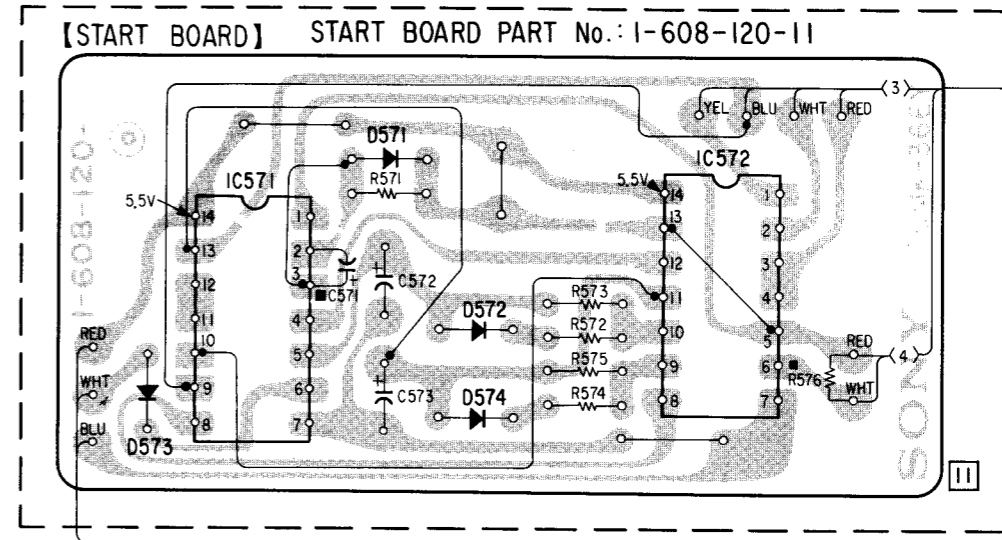
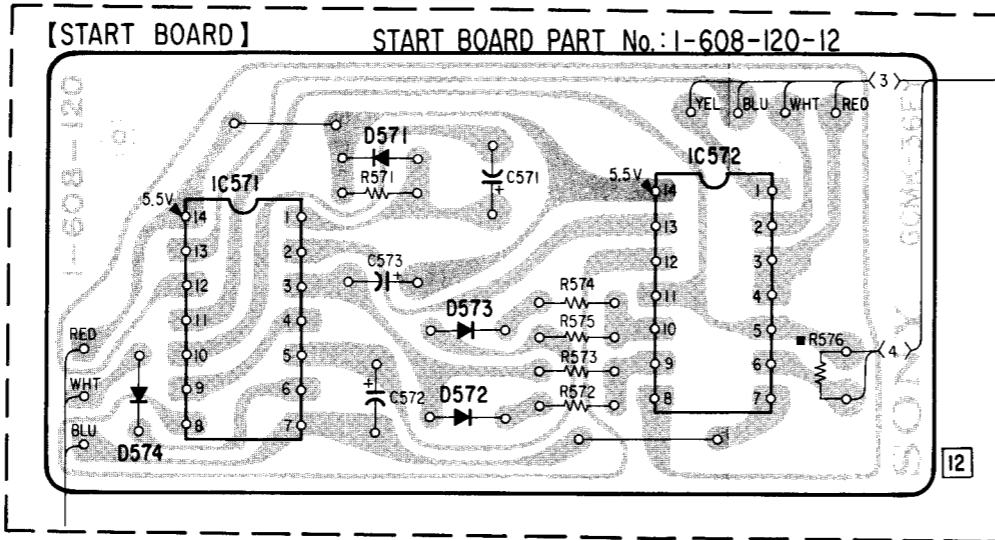

G

H

I

J

K

L

M

N

510	509 508 514	507	504 505 506	502 503	560	561	562	D
IC504	509 508 503 504	IC503 507 IC501	506 505	IC502	550			IC,Q

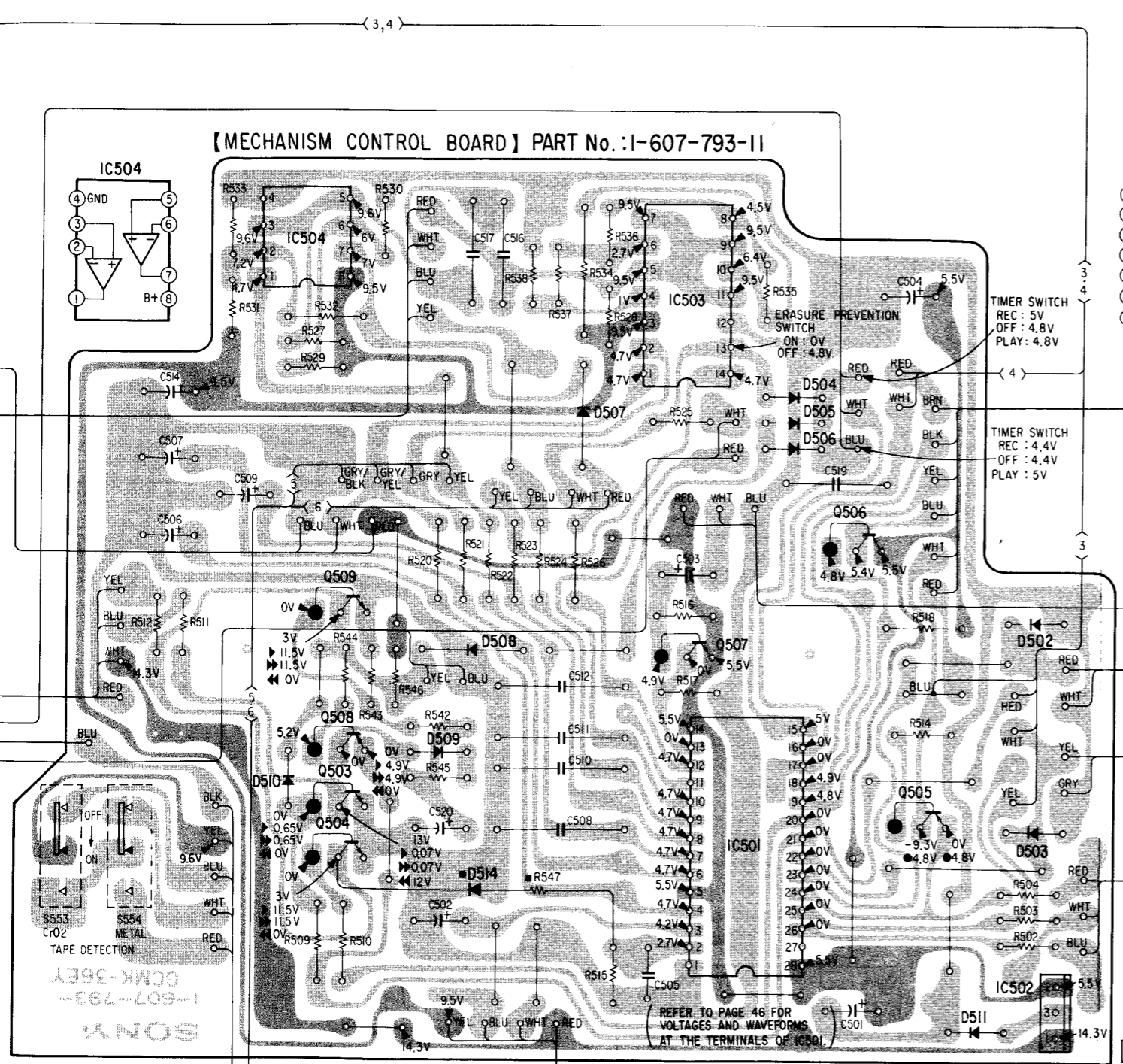

[INTERRUPT BOARD]

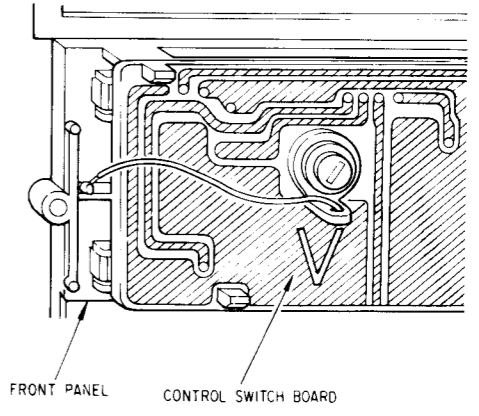
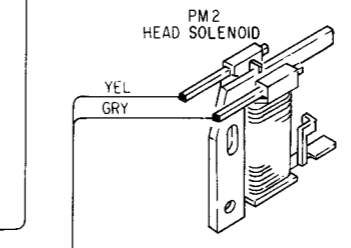
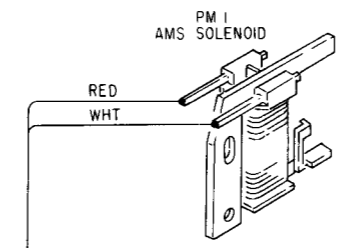
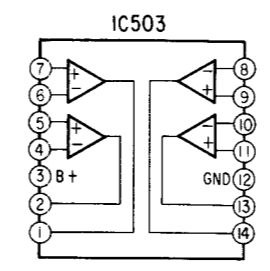
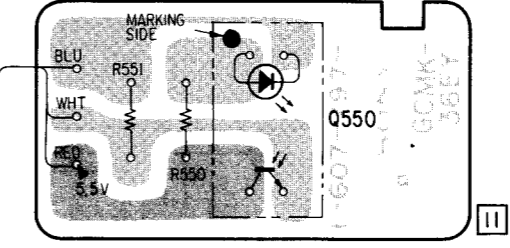

[CONTROL SWITCH BOARD]

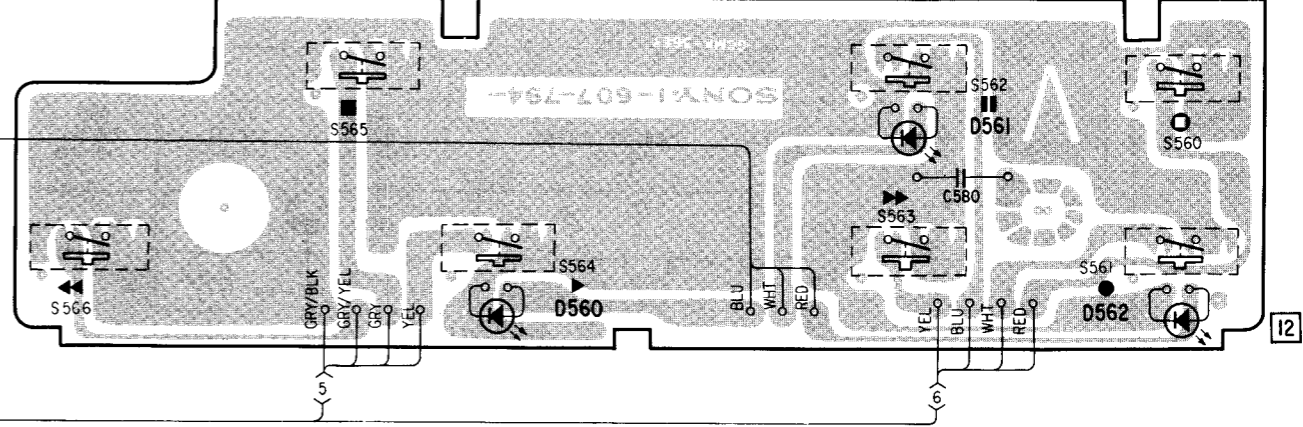

A REC/PB BOARD (TO PAGE 28)

C REC/PB BOARD (TO PAGE 28)

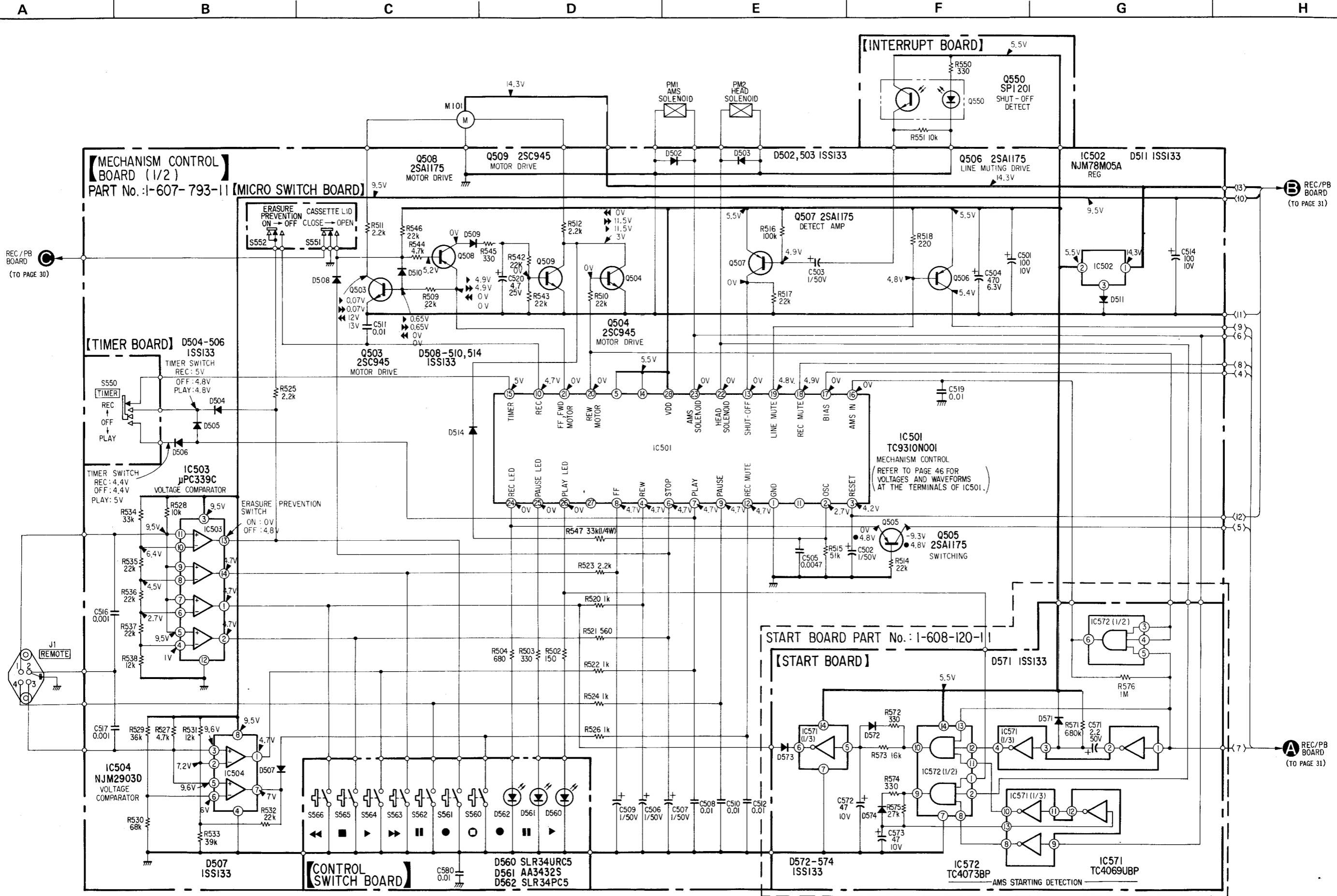

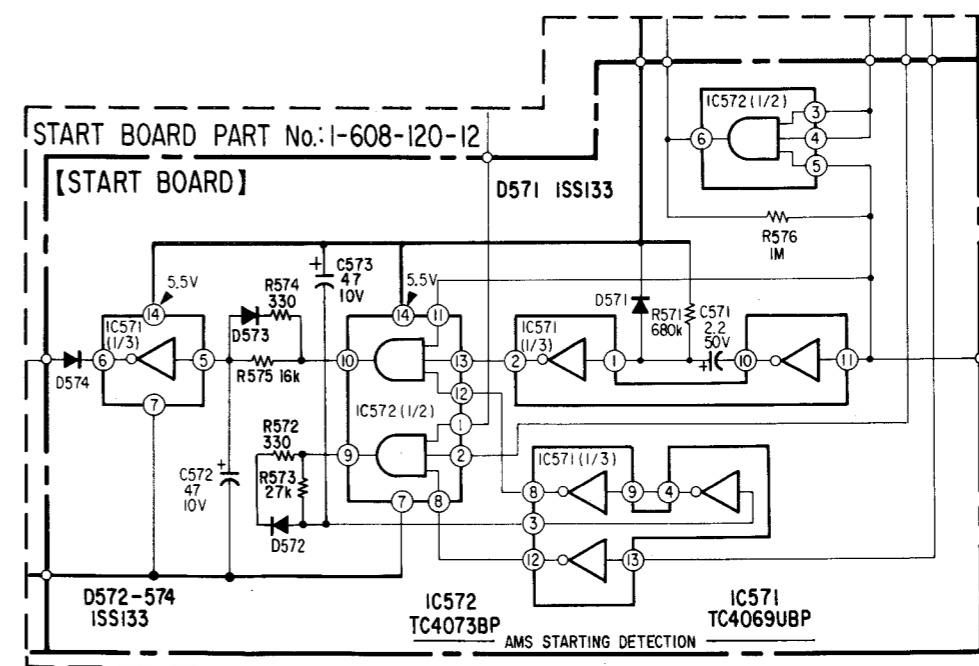
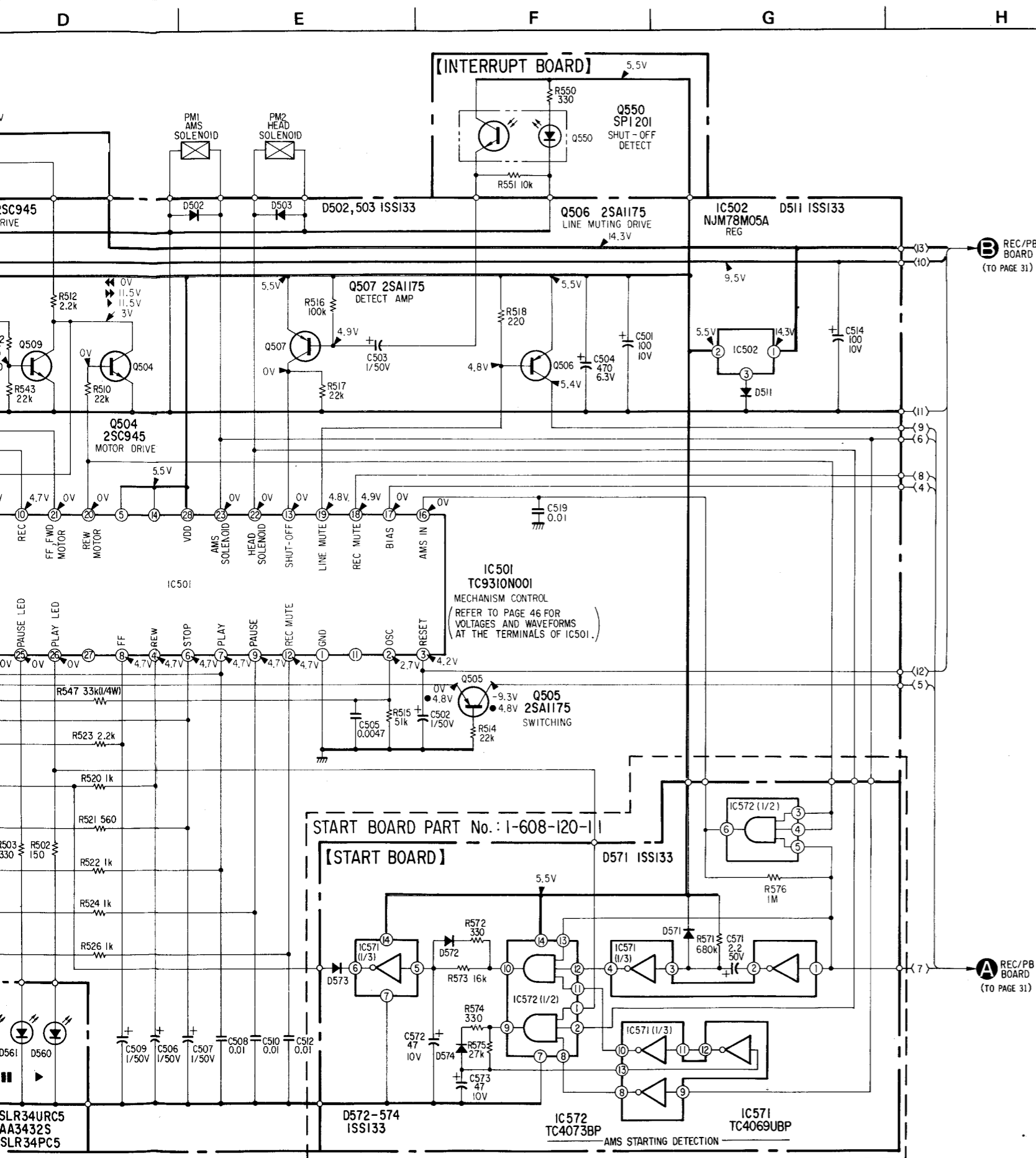

Note:

- All capacitors are in μF unless otherwise noted. $pF : \mu\mu F$ 50WV or less are not indicated except for electrolytics and tantalums.
- All resistors are in ohms, $\frac{1}{4} W$ unless otherwise noted. $k\Omega : 1000 \Omega$, $M\Omega : 1000 k\Omega$
- — : B+ bus.
- Voltages are dc with respect to ground unless otherwise noted.
- Readings are taken under the POWER switch to ON conditions with cassette installed.
no mark : stop
▶ : playback
▶▶ : fast forward
◀◀ : rewind
● : record
- Voltage variations may be noted due to normal production tolerances.

Note: Voltages are measured with a VOM (50k Ω/V).

1

2

3

4

5

A

B

C

D

E

F

G

H

	D	574	571	573	572	510	509	508	507	504	505	506	502	503
		IC571		IC572		IC504	509	508		IC503	506	505	502	503
1		IC,Q					508	514		507	IC501		511	IC502

1

【START BOARD】 PART No.: I-608-120-14

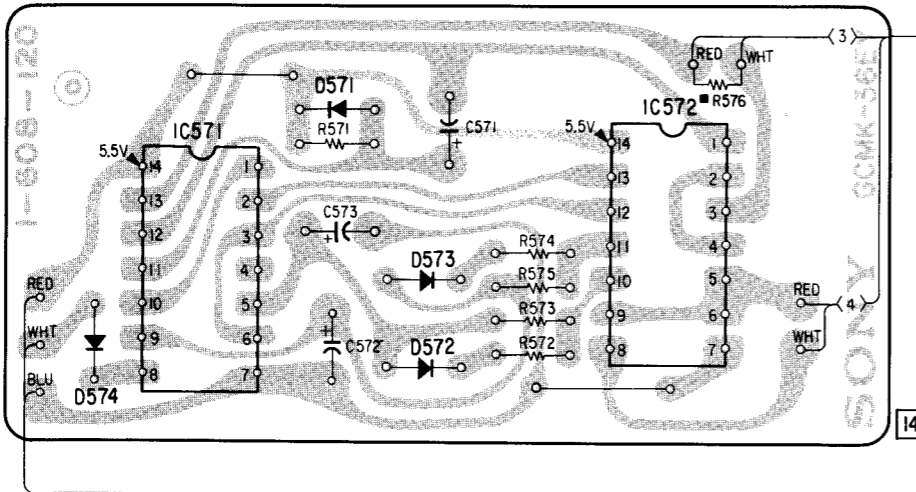

2

【MECHANISM CONTROL BOARD】 PART No. I-607-793-12

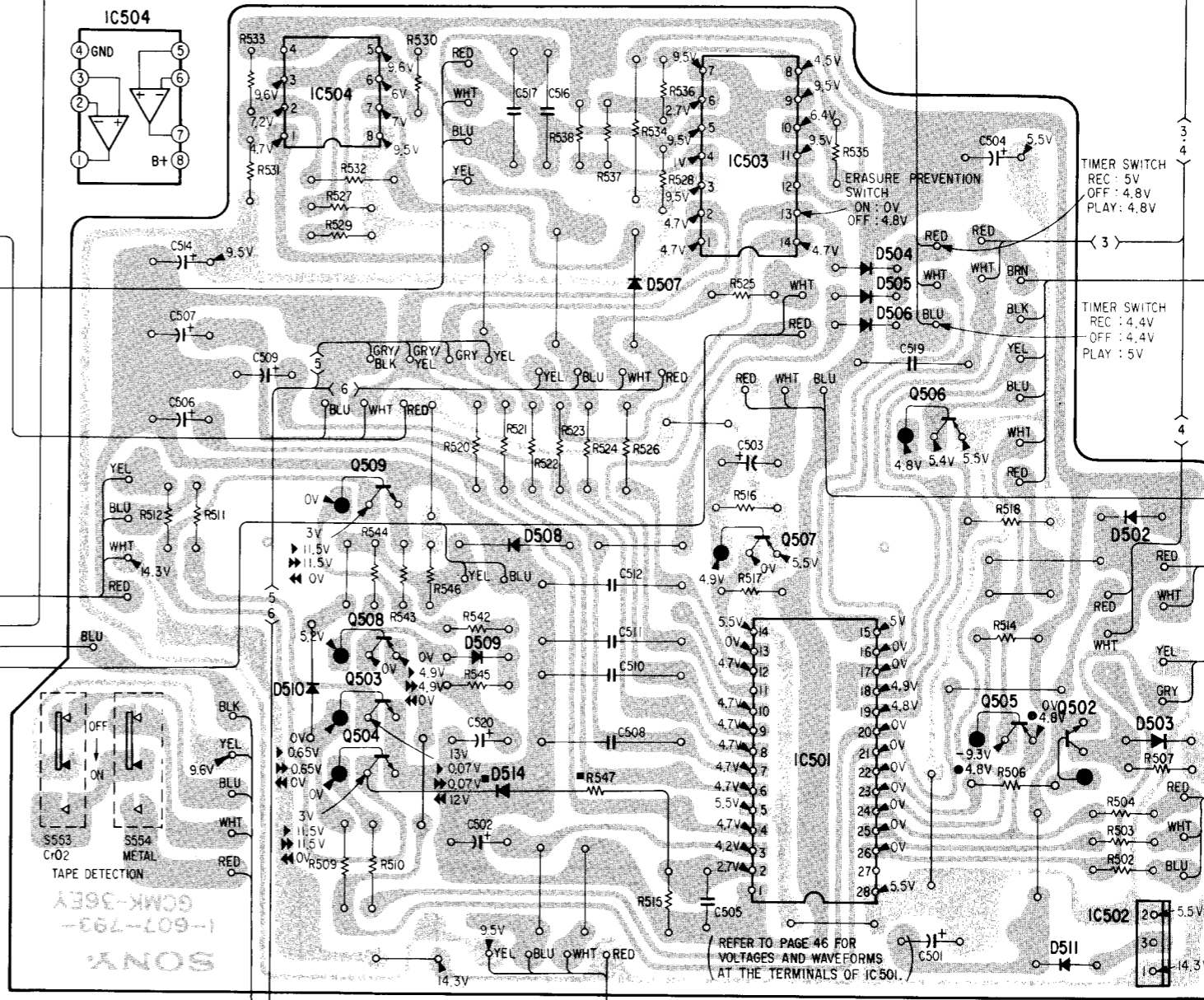

3

【REMOTE CONTROL SOCKET BOARD】

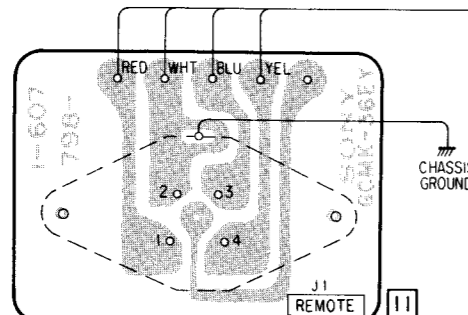

4

【TIMER BOARD】

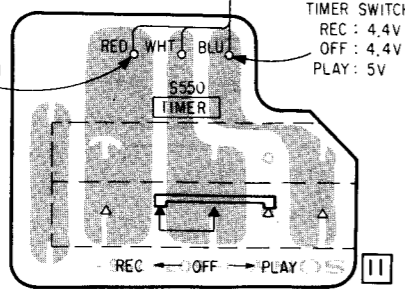

5

【MICRO SWITCH BOARD】

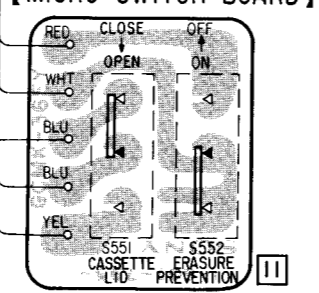

D E F G H I J K L

510	509	508	514	507	504	505	506	511	502	503	560	561	562	D
IC504	509	508			IC503		506	505	502	IC502	550			IC,Q
	503	504			507	IC501								

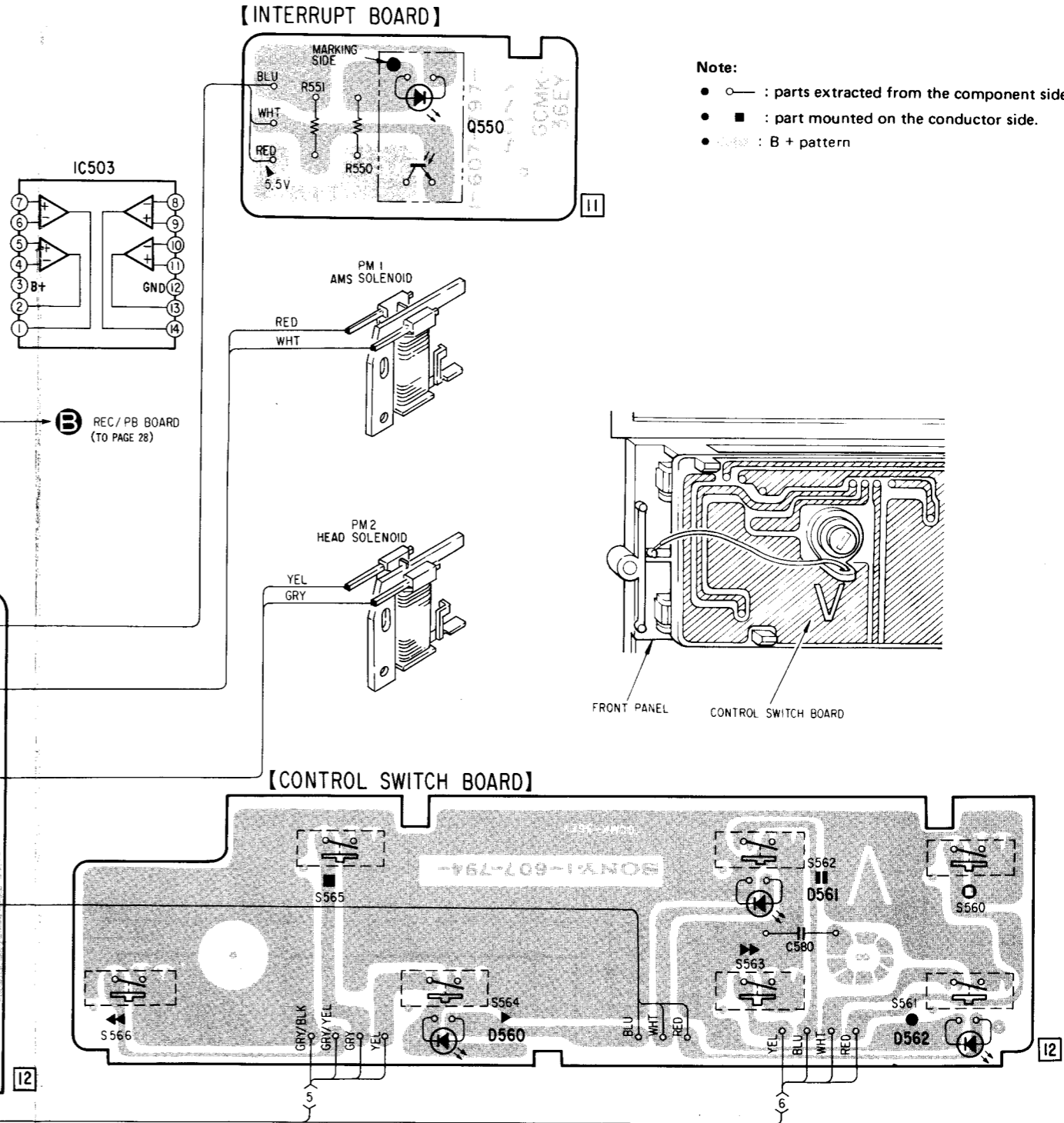
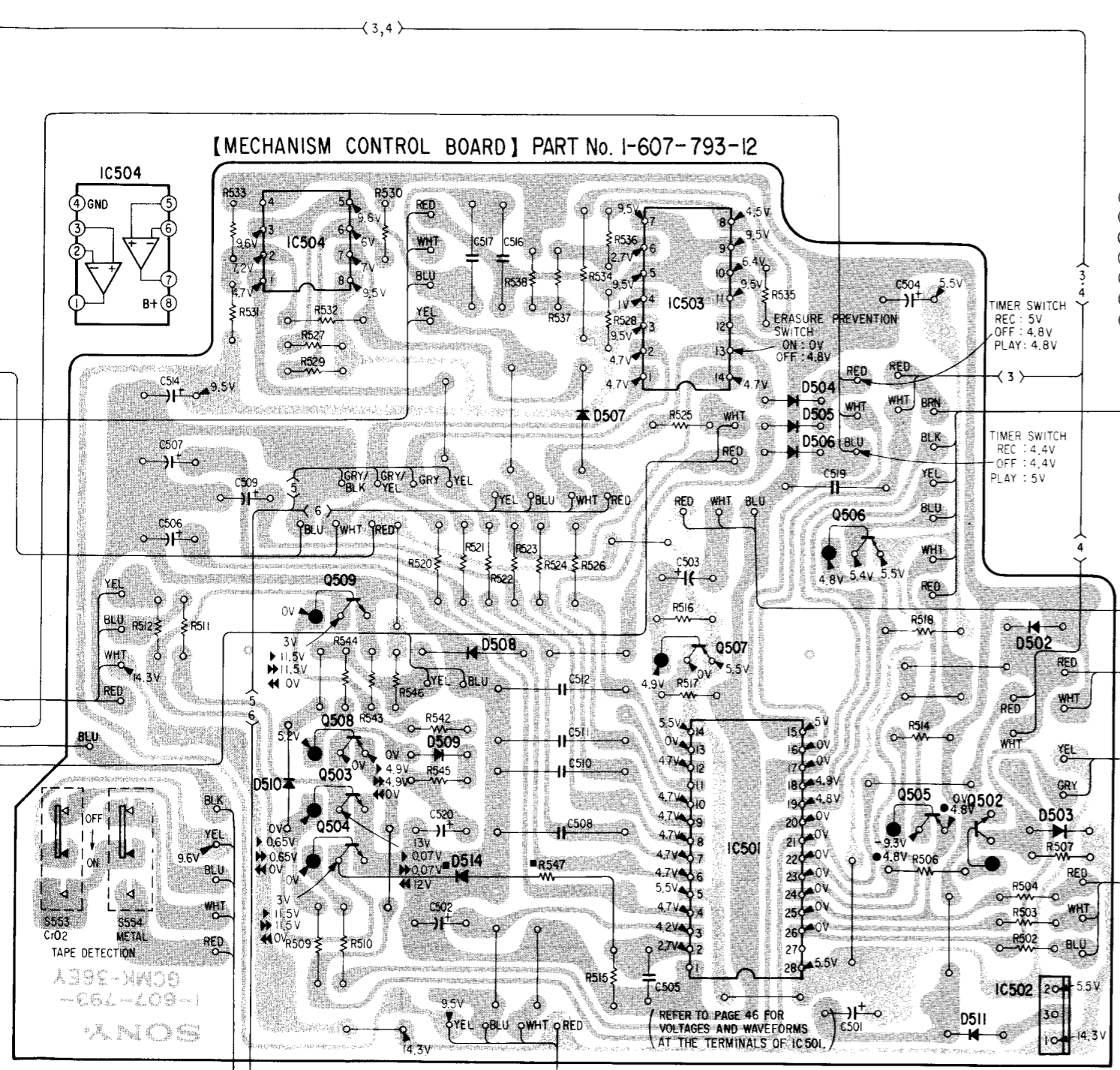

【INTERRUPT BOARD】

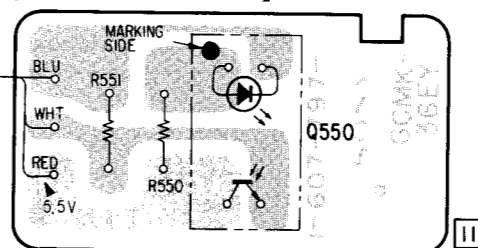

Note:
 ○ : parts extracted from the component side.
 ● : part mounted on the conductor side.
 ● : B + pattern

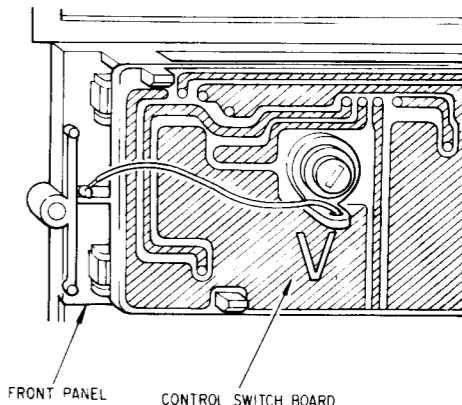

A REC/PB BOARD (TO PAGE 28)

C REC/PB BOARD (TO PAGE 28)

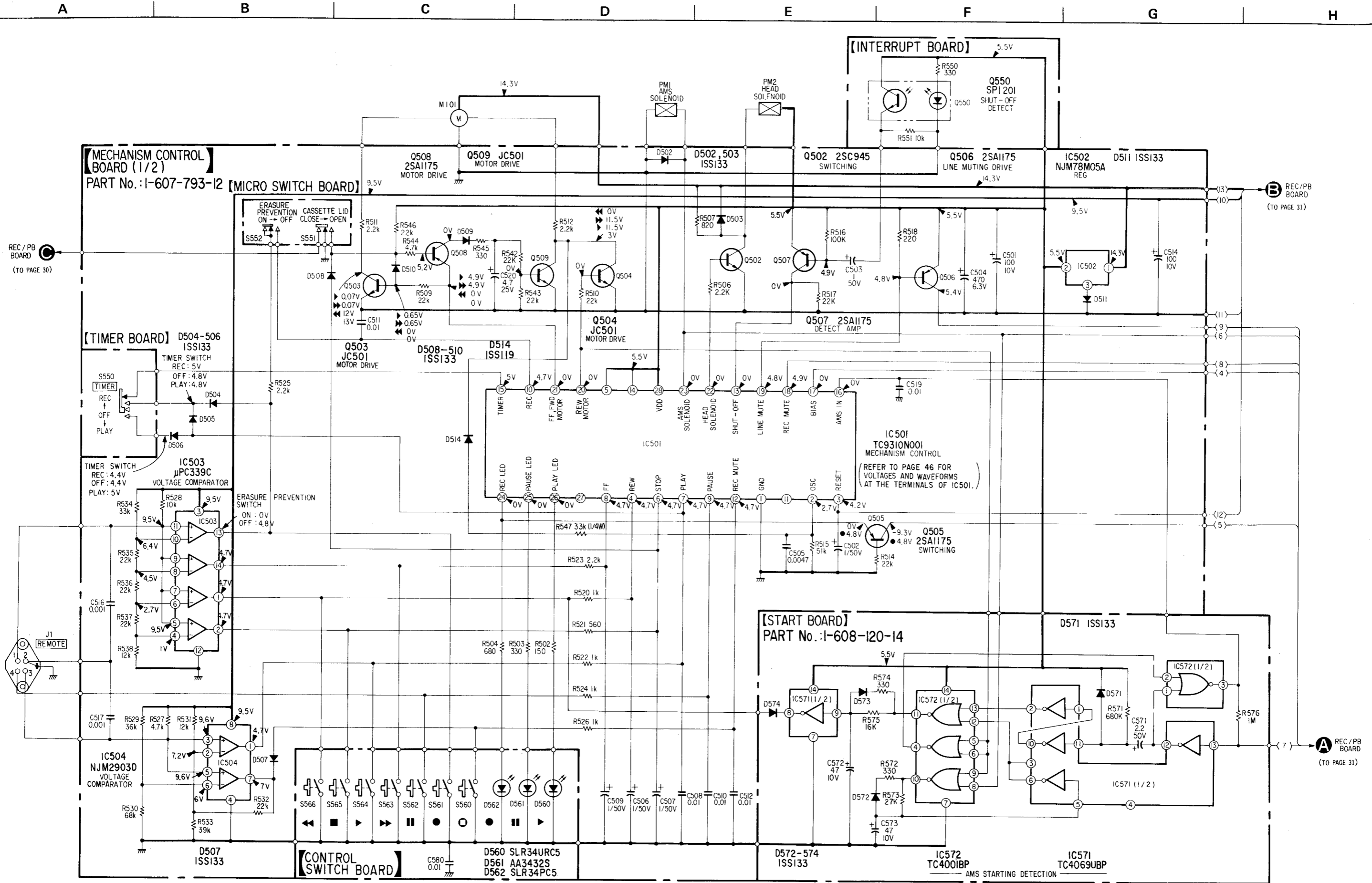

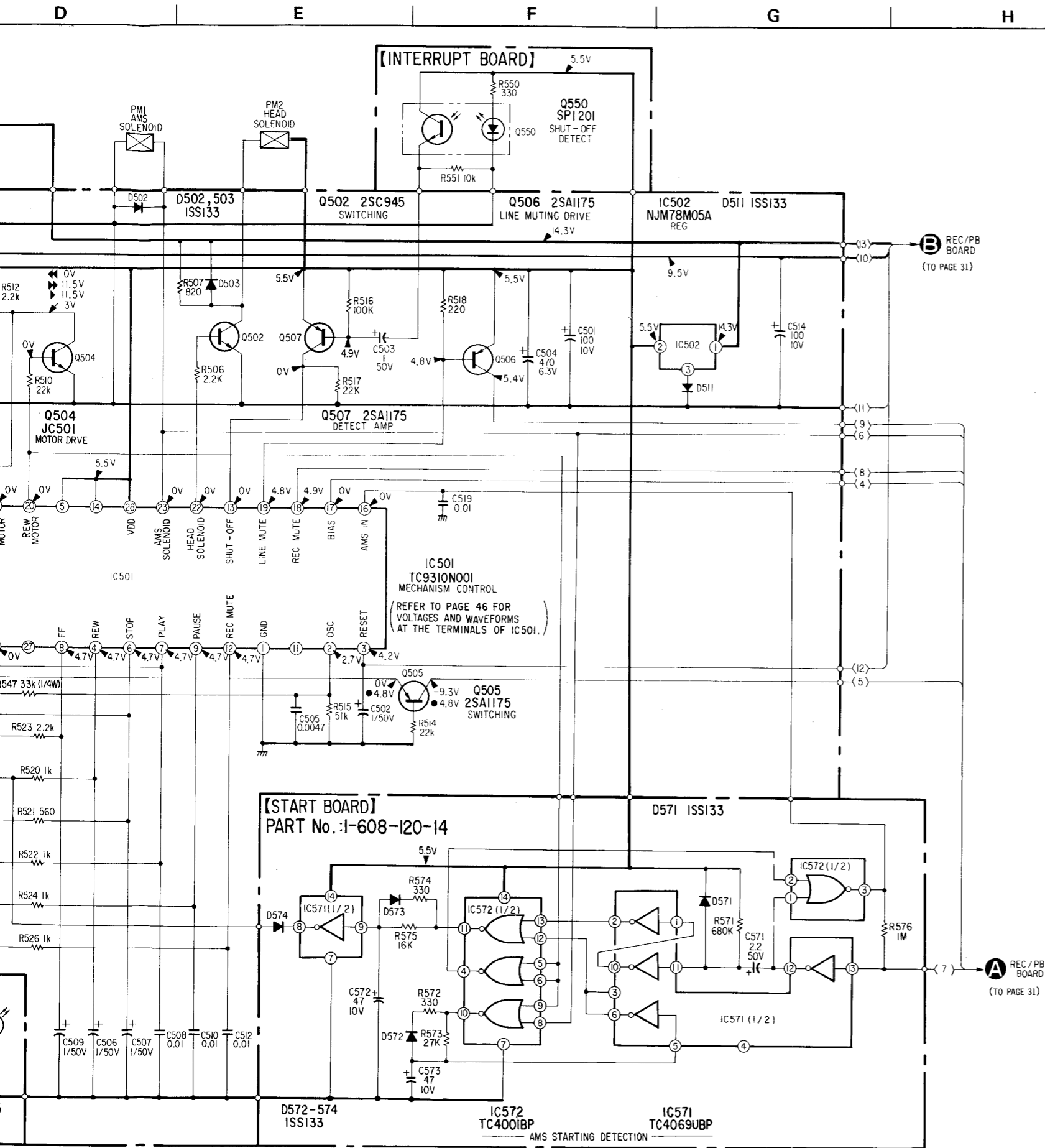

Semiconductor Lead Layouts

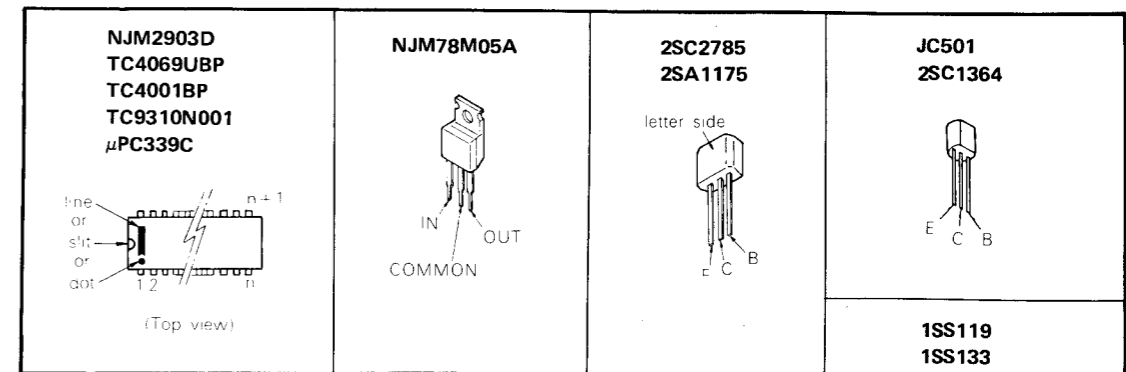

Note:

- All capacitors are in μF unless otherwise noted. pF : μμF 50WV or less are not indicated except for electrolytics and tantalums.
- All resistors are in ohms, 1/8 W unless otherwise noted. kΩ : 1000 Ω, MΩ : 1000 kΩ
- — : B+ bus.
- Voltages are dc with respect to ground unless otherwise noted.
- Readings are taken under the POWER switch to ON conditions with cassette installed.
 no mark : stop
 ▶ : playback
 ▶▶ : fast forward
 ◀◀ : rewind
 ● : record
- Voltage variations may be noted due to normal production tolerances.

Note: Voltages are measured with a VOM (50kΩ/V).

1
2
3
4
5

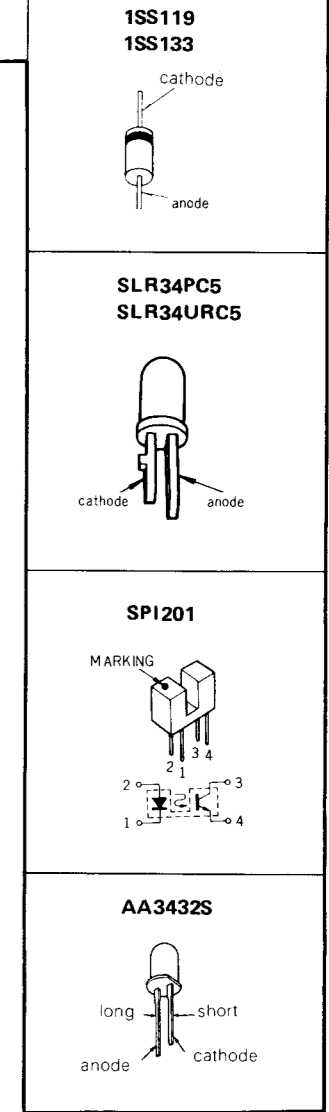
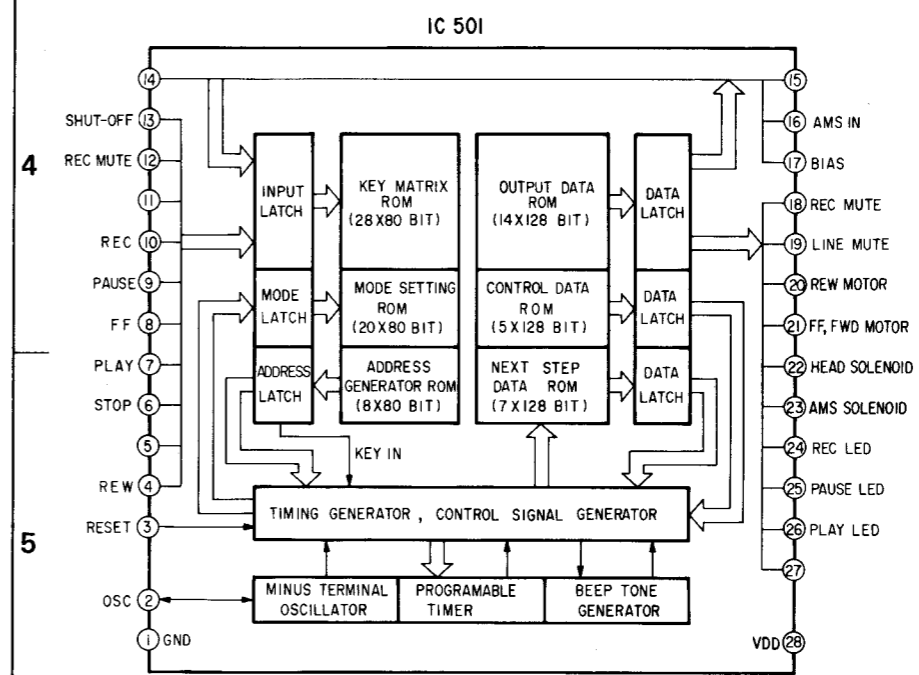

SECTION 5
EXPLODED VIEWS AND PARTS LIST

Voltages and Waveforms at the Terminals of IC501

Terminal No.	Waveform or Voltage	Terminal No.	Waveform or Voltage	Terminal No.	Waveform or Voltage
①	GND				
②		⑫		⑳	
③	4.2V dc				
④		⑬		㉑	
⑤	5.5V dc	⑭	5.5V dc	㉒	
⑥		⑮		㉓	
⑦		⑯	AMS signal 5.5V dc	㉔	
⑧		⑰		㉕	
⑨		⑱		㉖	
⑩		⑲		㉗	blank
⑪	blank			㉘	5.5V dc

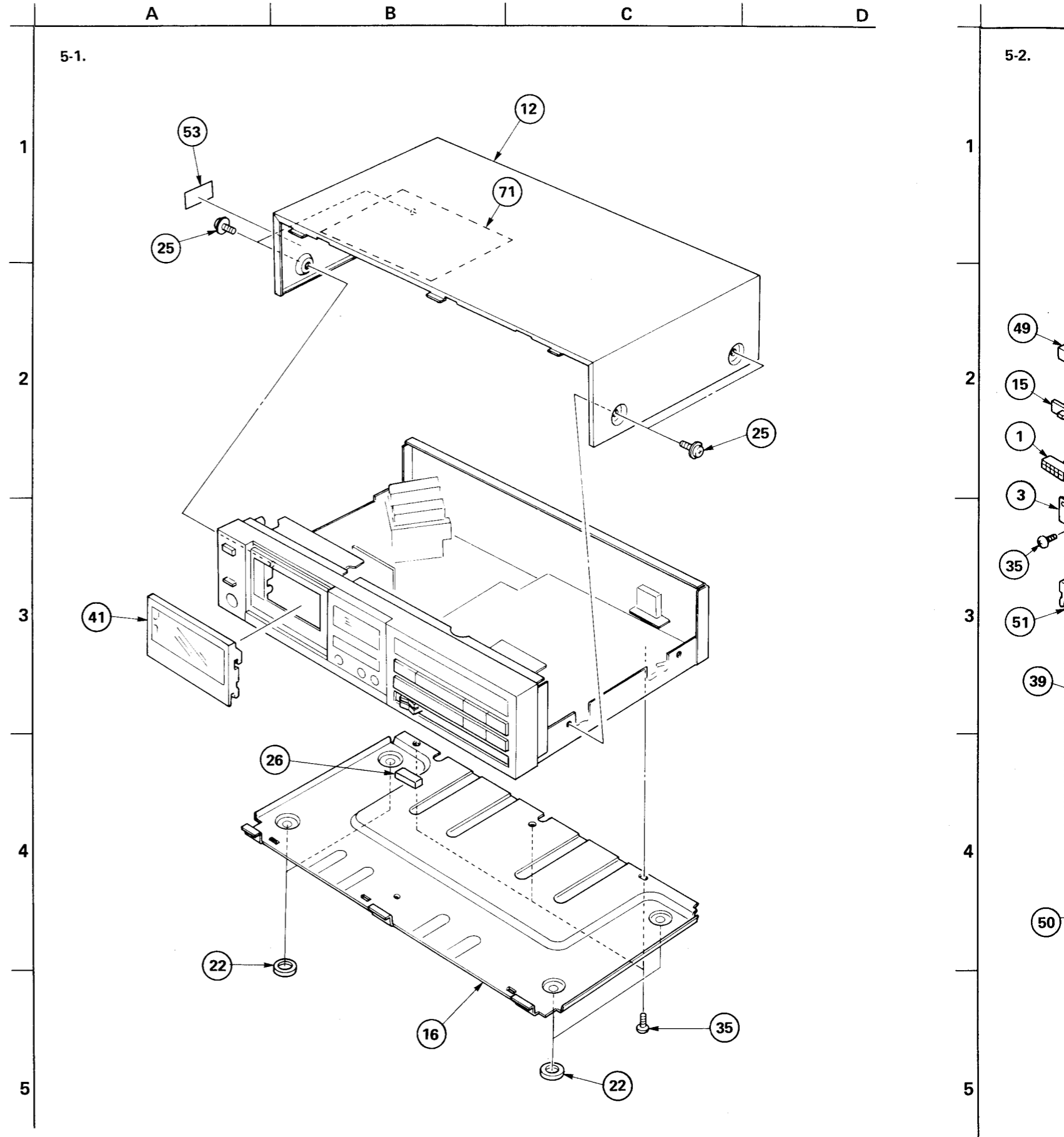

SECTION 5
EXPLODED VIEWS AND PARTS LIST

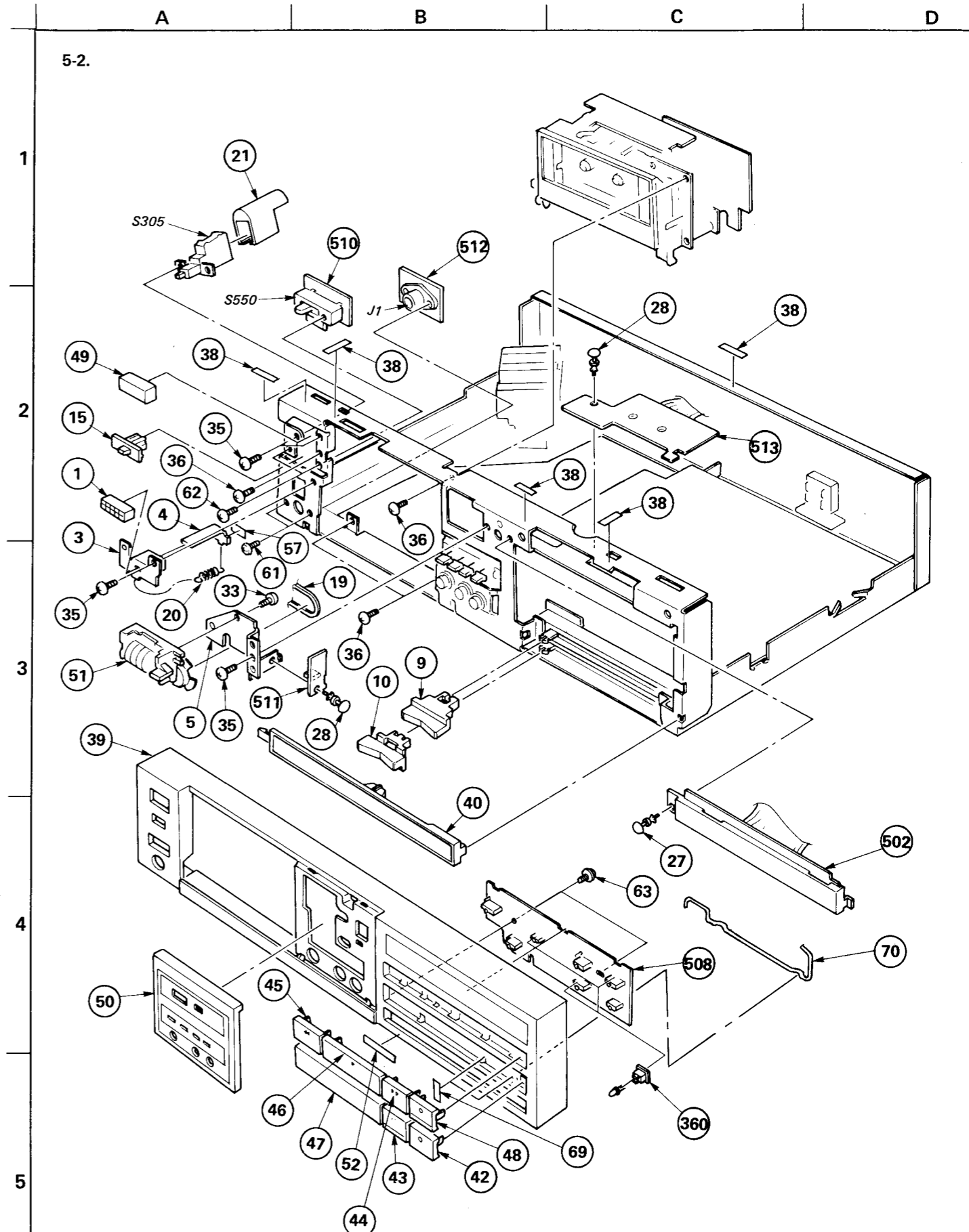
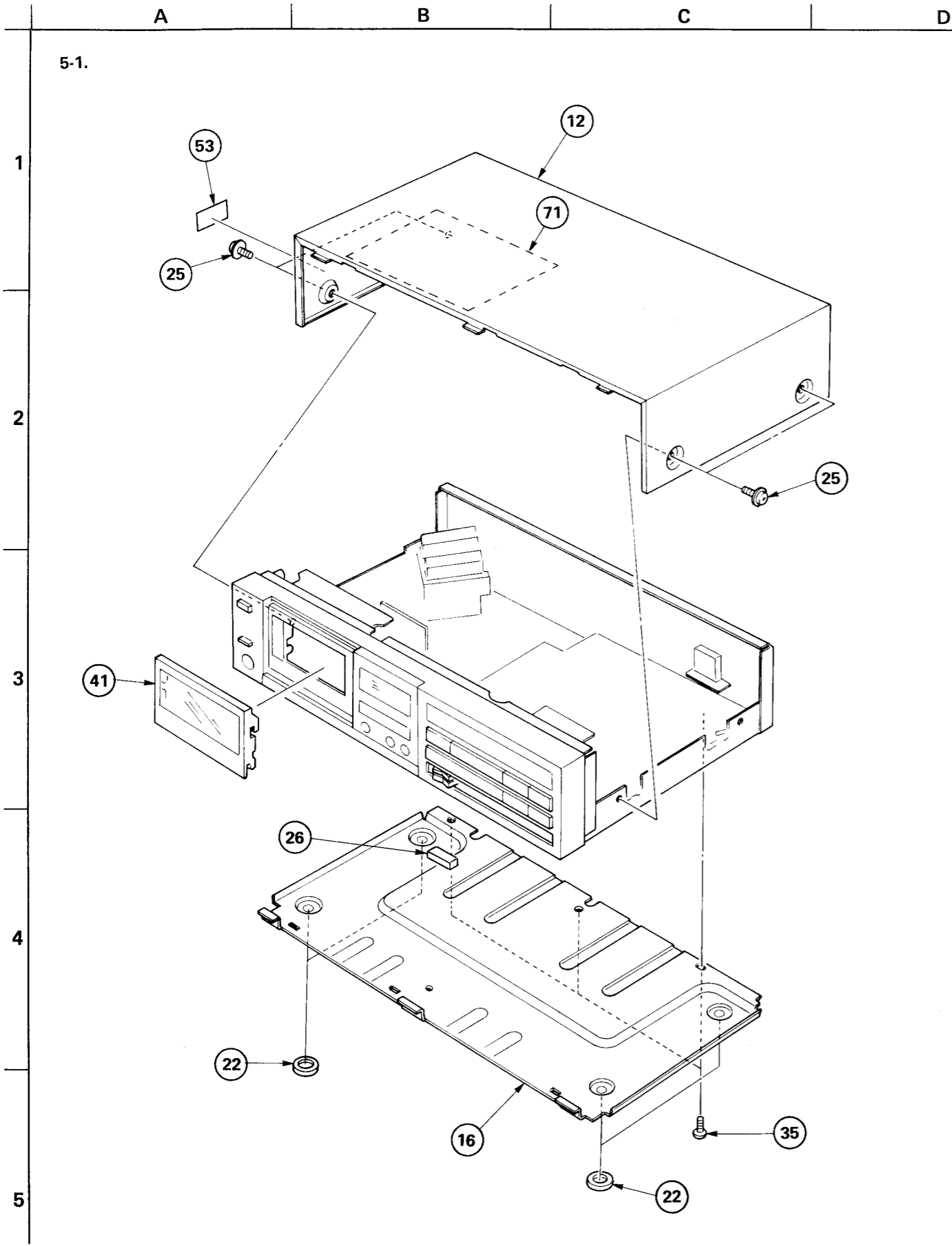

5-3.

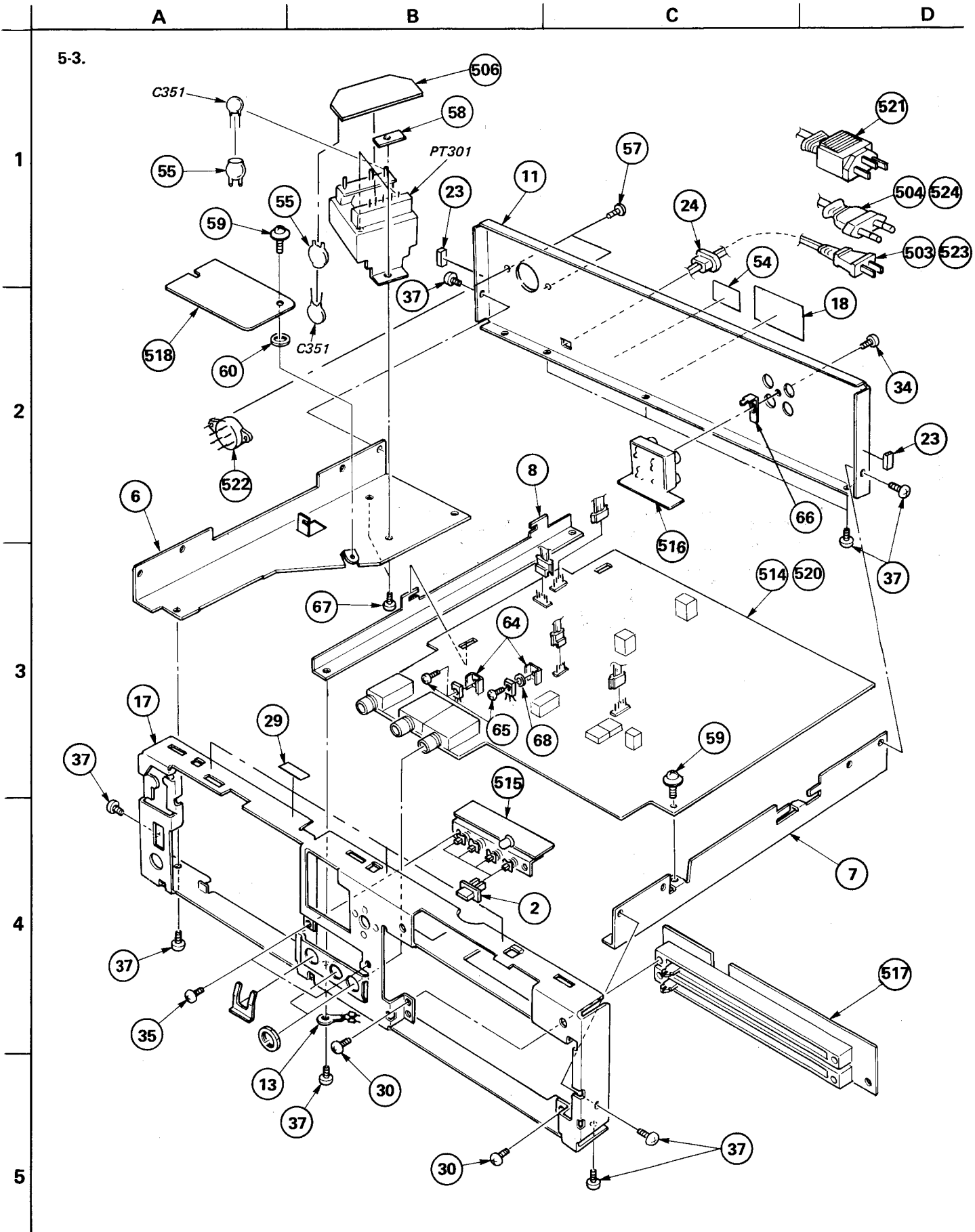

TC-FX44/FX44B

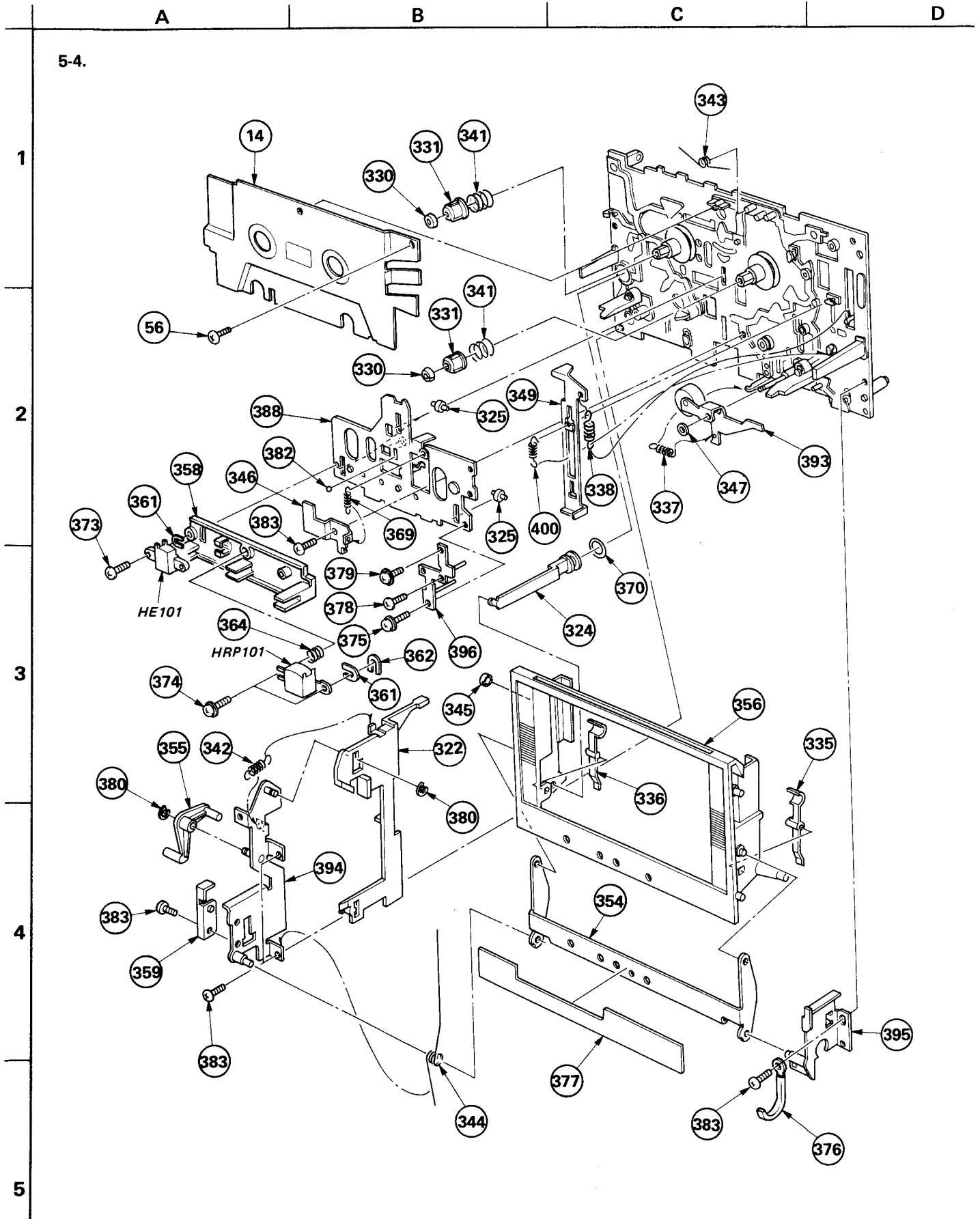

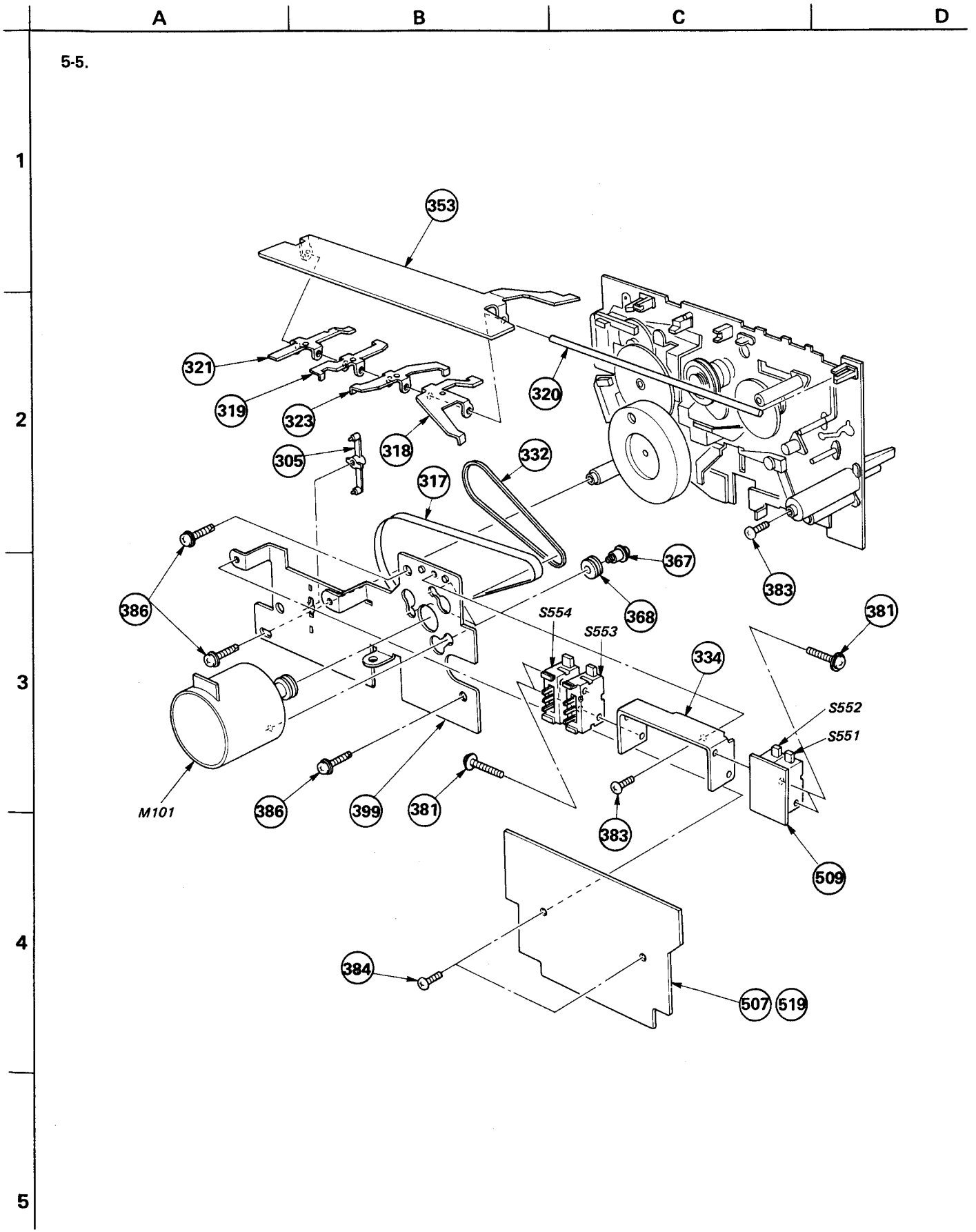

TC-FX44/FX44B

5-6.

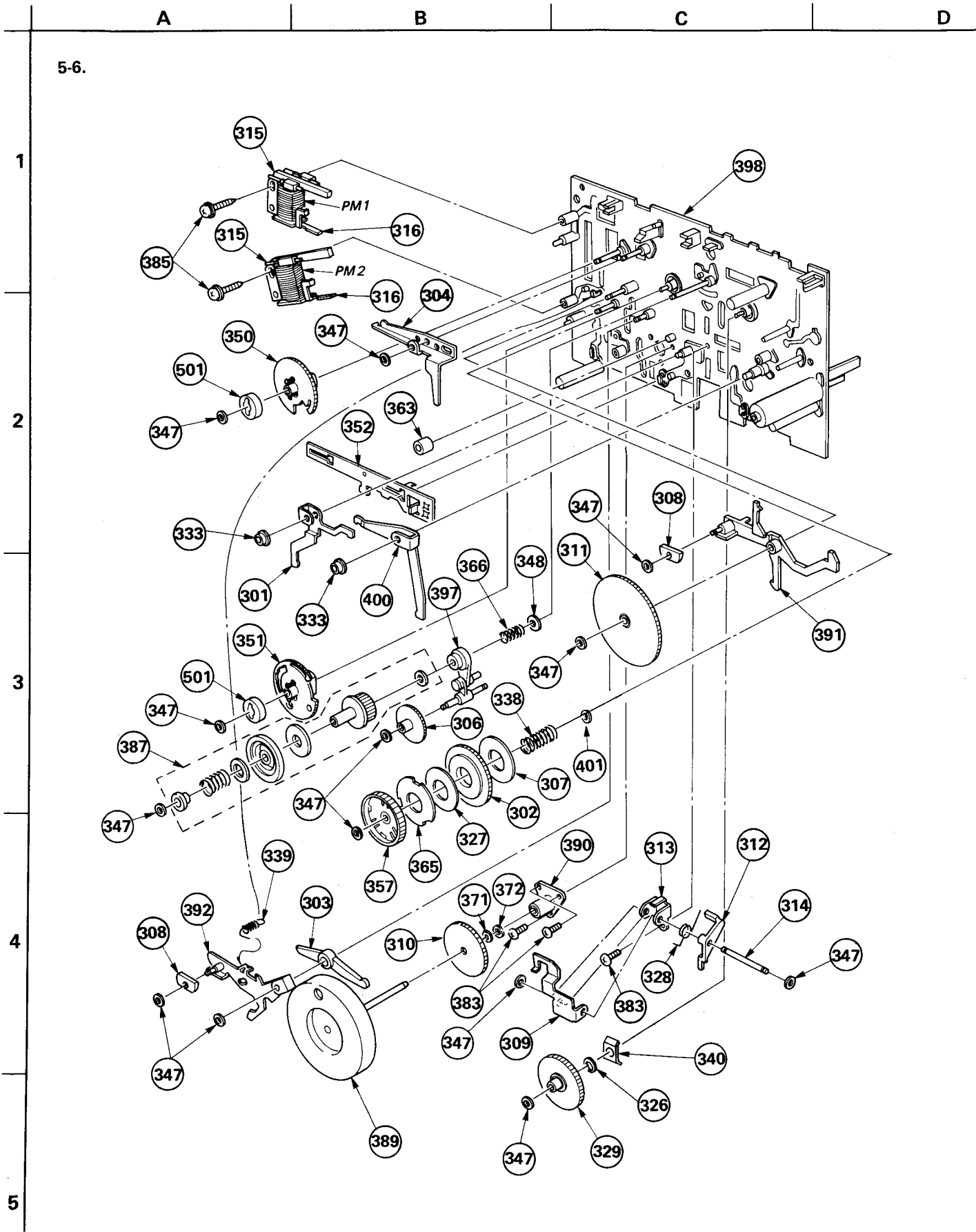

GENERAL SECTION

No.	Part No.	Description
1	3-304-419-00	(SILVER)...BUTTON, EJECT
1	3-304-419-31	(BLACK)...BUTTON, EJECT
2	3-307-515-00	BUTTON, DOLBY
3	♣;3-307-517-00	GUIDE, SLIDER
4	♣;3-307-518-00	PLATE, SLIDE
5	♣;3-307-519-00	BRACKET, COUNTER
6	♣;3-307-525-00	PLATE, SIDE, LEFT
7	♣;3-307-526-00	PLATE, SIDE, RIGHT
8	♣;3-307-527-00	PLATE, RELAY
9	3-307-528-00	(SILVER)...KNOB (LEFT), REC CONTROL
9	3-307-528-11	(BLACK)...KNOB (LEFT), REC CONTROL
10	3-307-529-00	(SILVER)...KNOB (RIGHT), REC CONTROL
10	3-307-529-11	(BLACK)...KNOB (RIGHT), REC CONTROL
11	♣;3-307-530-11	(US,Canadian,AEP,UK)...PLATE, JACK
11	♣;3-307-530-21	(E).....PLATE, JACK
12	3-307-532-00	(SILVER)...CASE
12	3-307-532-11	(BLACK)...CASE
13	3-460-077-00	CLAMP, WIRE
14	3-307-533-00	PLATE, ORNAMENTAL, MD
15	3-307-538-00	(SILVER)...KNOB, SWITCH, TIMER
15	3-307-538-21	(BLACK)...KNOB, SWITCH, TIMER
16	♣;3-307-540-00	PLATE, BOTTOM
17	♣;3-307-541-00	CHASSIS, AMPLIFIER
18	3-307-575-00	(AEP;BLACK).....LABEL, MODEL NUMBER
18	3-307-544-00	(AEP;SILVER).....LABEL, MODEL NUMBER
18	3-307-543-00	(US,Canadian)...LABEL, MODEL NUMBER
18	3-307-545-00	(UK).....LABEL, MODEL NUMBER
18	3-307-546-00	(E).....LABEL, MODEL NUMBER
19	3-480-135-00	BELT
20	3-540-244-00	SPRING, TENSION
21	3-575-524-00	COVER, POWER SWITCH
22	3-576-731-00	FELT (H)
23	9-911-840-XX	RUBBER (B)
24	3-703-244-00	BUSHING, CORD
25	3-703-354-01	(BLACK)...SCREW (OS), CASE, CLAW
25	3-703-354-11	(SILVER)...SCREW (OS), CASE, CLAW
26	9-911-851-XX	CUSHION
27	4-812-134-00	RIVET NYLON, 3.5
28	4-812-134-11	RIVET NYLON, 3.5
29	9-911-838-XX	SHEET, RUBBER
30	7-682-646-01	SCREW +PS 3X5
31	7-685-134-21	SCREW +P 2.6X8 TYPE2 SLIT
32	7-685-532-19	SCREW +BTP 2.6X5 TYPE2 N-S
33	7-685-533-19	SCREW +BTP 2.6X6 TYPE2 N-S
34	7-685-546-19	SCREW +BTP 3X8 TYPE2 N-S
35	7-685-871-01	SCREW +BVTT 3X6 (S)

GENERAL SECTION

No.	Part No.	Description
36	7-685-871-09	SCREW +BVTT 3X6 (S)
37	7-685-872-01	SCREW +BVTT 3X8 (S)
38	9-911-837-XX	CUSHION, FILTER
39	A-2310-202-A	(SILVER)...PANEL ASSY, FRONT
39	A-2310-213-A	(BLACK)...PANEL ASSY, FRONT
40	X-3307-501-0	(SILVER)...PLATE ASSY, ORNAMENTAL, BUTTON
40	X-3307-521-0	(BLACK)...PLATE ASSY, ORNAMENTAL, BUTTON
41	X-3307-502-0	(SILVER)...WINDOW ASSY, CASSETTE
41	X-3307-525-0	(BLACK)...WINDOW ASSY, CASSETTE
42	X-3307-503-0	(SILVER)...BUTTON ASSY, REC MUTE
42	X-3307-520-0	(BLACK)...BUTTON ASSY, REC MUTE
43	X-3307-504-0	(SILVER)...BUTTON ASSY, PAUSE
43	X-3307-519-0	(BLACK)...BUTTON ASSY, PAUSE
44	X-3307-505-0	(SILVER)...BUTTON ASSY, FF
44	X-3307-517-0	(BLACK)...BUTTON ASSY, FF
45	X-3307-506-0	(SILVER)...BUTTON ASSY, REW
45	X-3307-522-0	(BLACK)...BUTTON ASSY, REW
46	X-3307-507-0	(SILVER)...BUTTON ASSY, FWD
46	X-3307-524-0	(BLACK)...BUTTON ASSY, FWD
47	X-3307-508-0	(SILVER)...BUTTON ASSY, STOP
47	X-3307-523-0	(BLACK)...BUTTON ASSY, STOP
48	X-3307-509-0	(SILVER)...BUTTON ASSY, REC
48	X-3307-518-0	(BLACK)...BUTTON ASSY, REC
49	X-3575-502-0	(SILVER)...KNOB ASSY, POWER
49	X-3575-502-7	(BLACK)...KNOB ASSY, POWER
50	X-3307-513-0	ESCUTCHEON ASSY
51	1-548-536-71	COUNTER, TAPE
52	3-701-690-00	(UK).....LABEL (MADE IN JAPAN)
53	3-703-079-21	(UK,US).....LABEL, SUB-CAUTION
54	3-703-456-01	(AEP,UK)...LABEL, AMS LICENSE
55	4-875-455-21	(AEP,UK)...CAPACITOR COVER
56	7-685-103-69	SCREW +PTP 2X5 TYPE2
57	7-682-547-09	(E)...SCREW +B 3X6
58	3-536-212-00	NUT, PLATE
59	3-703-249-01	SCREW +PTTWH 3X6
60	7-623-955-11	WASHER
61	7-685-534-21	SCREW +B 2.6X8 TYPE2
62	7-621-775-25	SCREW +B 2.6X5
63	7-687-246-21	SCREW -PTPWH 3X8 TYPE2
64	♣;3-307-560-00	HEAT SINK
65	7-682-547-01	SCREW +B 3X6
66	♣;3-307-558-00	PLATE, GROUND, PIN JACK
67	7-682-948-01	SCREW +PSW 3X8
68	3-572-365-11	SHEET, INSULATING (A)
69	3-307-559-00	SHEET, GROUND
70	3-307-561-00	ROD, GROUND
71	♣;3-307-563-00	CUSHION, VIBRATION

NOTE:

- Items with no part number and no description are not stocked because they are seldom required for routine service.
- Items marked "♣" are not stocked since they are seldom required for routine service. Some delay should be anticipated when ordering these items.
- Due to standardization, parts with part numbers (Δ-ΔΔΔ-ΔΔΔ-XX or Δ-ΔΔΔΔ-ΔΔΔ-X) may be different from those used in the set.

CAPACITORS:

- All capacitors are in μF. Common capacitors are omitted. Refer to the following lists for their part numbers. MF:μF, PF:μμF.

RESISTORS

- All resistors are in ohms. Common 1/4W, 1/8W and 1/16W carbon resistors are omitted. Refer to the following lists for their part numbers.

- F : nonflammable

COILS

- MMH : mH, UH : μH

The components identified by shading and mark **♣** are critical for safety. Replace only with part number specified.

Les composants identifiés par une trame et une marque **♣** sont critiques pour la sécurité. Ne les remplacer que par une pièce portant le numéro spécifié.

SEMICONDUCTORS

In each case, U : μ, for example:
 UA...: μA...; UPA...: μPA...; UPC...: μPC,
 UPD...: μPD...

TC-FX44/FX44B

ACCESSORY & PACKING MATERIAL

Part No.	Description
1-551-734-11	CORD, CONNECTION (RK-74A)
▲ 1-551-967-00	(UK)....CORD, POWER
3-307-553-00	(SILVER)...INDIVIDUAL CARTON
3-307-574-00	(BLACK)....INDIVIDUAL CARTON
3-307-554-00	CUSHION, UPPER, RIGHT
3-307-555-00	CUSHION, UPPER, LEFT
3-307-556-00	CUSHION, LOWER, RIGHT
3-307-557-00	CUSHION, LOWER, LEFT
3-307-562-00	LABEL, CAUTION, TAPE SELECT
3-701-630-00	BAG, POLYETHYLENE, FOR INSTRUCTION MANUAL
3-773-051-11	(UK,E,AEP;SILVER)...MANUAL, INSTRUCTION
3-773-255-11	(AEP;BLACK).....MANUAL, INSTRUCTION
3-773-051-41	(AEP;SILVER).....MANUAL, INSTRUCTION
3-773-255-41	(AEP;BLACK).....MANUAL, INSTRUCTION
3-773-051-21	(US,Canadian).....MANUAL, INSTRUCTION
3-773-051-31	(Canadian).....MANUAL, INSTRUCTION
3-793-828-11	QUESTIONNAIRE
4-876-352-00	SHEET, PROTECTION, FOR SET
8-890-454-10	(Canadian)...TAPE (UCX-S)
X-3701-105-0	ROD ASSY, CLEANING, HEAD

MECHANISM SECTION

No.	Part No.	Description
301	▲;3-307-301-00	LEVER (RELAY), FWD SELECT
302	3-307-953-00	MAGNET, REEL TABLE
303	3-307-307-00	LEVER, FWD
304	▲;3-307-308-00	LEVER, FF
305	3-307-309-00	RETAINER (A), THRUST
306	3-307-312-00	GEAR, FR
307	3-307-313-00	PLATE, YOKE
308	3-307-315-00	ARBOR, MOVABLE
309	3-307-319-00	RETAINER, TAKE-UP GEAR
310	3-307-320-00	GEAR (T), PINION
311	3-307-321-00	GEAR (T), DRIVING
312	3-307-328-00	LEVER, TAKE-UP SELECTION
313	▲;3-307-329-00	PLATE, FULCRUM, SELECTION LEVER
314	3-307-330-00	PIN, FULCRUM PLATE
315	3-307-332-00	ARBOR, FIXED
316	3-307-333-00	ARBOR, TRIGGER
317	3-307-483-00	BELT (R), CAPSTAN
318	▲;3-307-337-00	LEVER, REC DETECTION
319	▲;3-307-338-00	LEVER, METAL DETECTION
320	▲;3-307-339-00	SHAFT, DETECTION LEVER
321	▲;3-307-344-00	LEVER, HALF RETAINER
322	3-307-345-00	SLIDER, EJECT
323	▲;3-307-346-00	LEVER, DETECTION
324	3-307-347-00	PISTON
325	3-307-348-00	ROLLER
326	3-307-369-00	FELT, LIMITER
327	3-307-958-00	WASHER, POLYETHYLENE
328	3-307-355-00	SPRING
329	3-307-360-00	GEAR (S), REEL
330	3-307-362-00	CAP, REEL
331	3-307-363-00	CLAW (N), REEL
332	3-307-366-00	BELT, FAST FORWARD
333	3-307-367-00	BUSHING, SELECT LEVER
334	▲;3-307-370-00	BRACKET, SWITCH
335	3-307-371-00	SPRING (LEFT)
336	3-307-372-00	SPRING (RIGHT)
337	3-527-189-00	SPRING, TENSION
338	3-307-471-00	SPRING, TENSION
339	3-307-378-00	SPRING, TENSION
340	3-307-475-00	PLATE, TENSION, BACK
341	3-307-380-00	SPRING, COMPRESSION
342	3-531-541-00	SPRING, TENSION
343	3-307-382-00	SPRING
344	3-307-383-00	SPRING
345	3-307-390-00	BUSHING, LOADING SPRING

NOTE:

- Items with no part number and no description are not stocked because they are seldom required for routine service.
- Items marked "▲" are not stocked since they are seldom required for routine service. Some delay should be anticipated when ordering these items.
- Due to standardization, parts with part numbers (▲-▲▲▲-▲▲▲-XX or ▲-▲▲▲-▲▲▲-X) may be different from those used in the set.

CAPACITORS:

- All capacitors are in μF . Common capacitors are omitted. Refer to the following lists for their part numbers.
MF: μF , PF: $\mu\mu\text{F}$.

RESISTORS

- All resistors are in ohms. Common 1/4W, 1/8W and 1/16W carbon resistors are omitted. Refer to the following lists for their part numbers.

- F : nonflammable

COILS

- MMH : mH, UH : μH

The components identified by shading and mark ▲ are critical for safety. Replace only with part number specified.

Les composants identifiés par une trame et une marque ▲ sont critiques pour la sécurité. Ne les remplacer que par une pièce portant le numéro spécifié.

SEMICONDUCTORS

- In each case, U : μ , for example:
UA.... : μA ..., UPA.... : μPA ..., UPC.... : μPC ,
UPD.... : μPD ...

MECHANISM SECTION

Table with columns: No., Part No., Description. Lists various mechanical parts like springs, retainers, gears, levers, etc.

MECHANISM SECTION

Table with columns: No., Part No., Description. Lists various mechanical parts like lever assemblies, plates, chassis, etc.

ELECTRICAL PARTS

Table with columns: Ref.No., Part No., Description. Lists electrical components like magnets, meter units, PC boards, etc.

ELECTRICAL PARTS

Table with columns: Ref.No., Part No., Description. Lists electrical components like selectors, capacitors, resistors, diodes, etc.

ELECTRICAL PARTS

Table with columns: Ref.No., Part No., Description. Lists electrical components like capacitors, connectors, tuning capacitors, diodes, etc.

NOTE: Items with no part number and no description are not stocked because they are seldom required for routine service.

CAPACITORS: All capacitors are in µF. Common capacitors are omitted. Refer to the following lists for their part numbers.

The components identified by shading and mark ▲ are critical for safety. Replace only with part number specified.

NOTE: Items with no part number and no description are not stocked because they are seldom required for routine service.

CAPACITORS: All capacitors are in µF. Common capacitors are omitted. Refer to the following lists for their part numbers.

The components identified by shading and mark ▲ are critical for safety. Replace only with part number specified.

SEMICONDUCTORS In each case, U : µ, for example: UA...: µA...: UPA...: µPA...: UPC...: µPC, UPD...: µPD...

SEMICONDUCTORS In each case, U : µ, for example: UA...: µA...: UPA...: µPA...: UPC...: µPC, UPD...: µPD...

TC-FX44/FX44B TC-FX44/FX44B

ELECTRICAL PARTS

Ref.No.	Part No.	Description
D573	8-719-901-33	DIODE 1SS133
D574	8-719-901-33	DIODE 1SS133
HE101	8-825-724-00	HEAD, ERASE EF-201-36
HRP101	8-829-373-30	HEAD, REC/PB (PP181-3602C)
IC101	8-759-300-74	IC CX174A
IC102	8-759-300-74	IC CX174A
IC201	8-759-300-74	IC CX174A
IC202	8-759-300-74	IC CX174A
IC301	8-759-700-39	IC NJM4562S-D
IC302	8-759-600-02	IC M5218L
IC501	8-759-200-63	IC TC9310N001
IC502	8-759-700-11	IC NJM78M05A
IC503	8-759-133-90	IC UPC339C
IC504	8-759-729-03	IC NJM2903D
IC571	8-759-240-69	IC TC4069UBP
IC572	8-759-240-73	(SILVER;FORMER MODEL).....IC TC4073BP
IC572	8-759-240-01	(SILVER,BLACK;NEW MODEL)...IC TC4001BP
J1	1-561-965-00	SOCKET 5P
J101	1-507-797-00	JACK (LARGE)
J201	1-507-797-00	JACK (LARGE)
J102	1-507-762-00	JACK, PIN 4P
J103		
J202		
J203		
J301	1-507-796-00	JACK
L101	1-408-214-00	MICRO INDUCTOR 3.9MMH
L102	1-407-963-00	MICRO INDUCTOR 15MMH
L103	1-408-262-00	MICRO INDUCTOR 27MMH
L201	1-408-214-00	MICRO INDUCTOR 3.9MMH
L202	1-407-963-00	MICRO INDUCTOR 15MMH
L203	1-408-262-00	MICRO INDUCTOR 27MMH
L301	1-407-177-XX	MICRO INDUCTOR 470UH
LPF101	1-231-388-00	FILTER, LOWPASS
LPF201	1-231-388-00	FILTER, LOWPASS
M101	X-3307-308-0	MOTOR (N) ASSY
PM1	1-454-316-00	SOLENOID, PLUNGER
PM2	1-454-316-00	SOLENOID, PLUNGER
PT301A	1-447-356-00	(US,Canadian)...TRANSFORMER, POWER
PT301A	1-447-357-00	(E).....TRANSFORMER, POWER
PT301A	1-447-358-00	(AEP,UK).....TRANSFORMER, POWER
Q101	8-729-334-58	TRANSISTOR 2SC1345
Q102	8-729-334-58	TRANSISTOR 2SC1345
Q103	8-729-663-47	TRANSISTOR 2SC1364

ELECTRICAL PARTS

Ref.No.	Part No.	Description
Q105	8-729-663-47	TRANSISTOR 2SC1364
Q106	8-729-663-47	TRANSISTOR 2SC1364
Q107	8-729-663-47	TRANSISTOR 2SC1364
Q108	8-729-663-47	TRANSISTOR 2SC1364
Q109	8-729-663-47	TRANSISTOR 2SC1364
Q110	8-729-663-47	TRANSISTOR 2SC1364
Q111	8-729-663-47	TRANSISTOR 2SC1364
Q112	8-729-663-47	TRANSISTOR 2SC1364
Q113	8-729-663-47	TRANSISTOR 2SC1364
Q114	8-729-663-47	TRANSISTOR 2SC1364
Q115	8-729-100-13	TRANSISTOR 2SC2001
Q116	8-729-663-47	TRANSISTOR 2SC1364
Q117	8-729-663-47	TRANSISTOR 2SC1364
Q118	8-729-663-47	TRANSISTOR 2SC1364
Q119	8-729-663-47	TRANSISTOR 2SC1364
Q201	8-729-334-58	TRANSISTOR 2SC1345
Q202	8-729-334-58	TRANSISTOR 2SC1345
Q203	8-729-663-47	TRANSISTOR 2SC1364
Q205	8-729-663-47	TRANSISTOR 2SC1364
Q206	8-729-663-47	TRANSISTOR 2SC1364
Q207	8-729-663-47	TRANSISTOR 2SC1364
Q208	8-729-663-47	TRANSISTOR 2SC1364
Q209	8-729-663-47	TRANSISTOR 2SC1364
Q210	8-729-663-47	TRANSISTOR 2SC1364
Q211	8-729-663-47	TRANSISTOR 2SC1364
Q212	8-729-663-47	TRANSISTOR 2SC1364
Q213	8-729-663-47	TRANSISTOR 2SC1364
Q214	8-729-663-47	TRANSISTOR 2SC1364
Q215	8-729-100-13	TRANSISTOR 2SC2001
Q216	8-729-663-47	TRANSISTOR 2SC1364
Q217	8-729-663-47	TRANSISTOR 2SC1364
Q218	8-729-663-47	TRANSISTOR 2SC1364
Q301	8-729-612-77	TRANSISTOR 2SA1027R
Q302	8-729-663-47	TRANSISTOR 2SC1364
Q303	8-729-663-47	TRANSISTOR 2SC1364
Q304	8-729-663-47	TRANSISTOR 2SC1364
Q306	8-729-663-47	TRANSISTOR 2SC1364
Q307	8-729-663-47	TRANSISTOR 2SC1364
Q308	8-729-141-43	TRANSISTOR 2SD414
Q309	8-729-663-47	TRANSISTOR 2SC1364
Q310	8-729-663-47	TRANSISTOR 2SC1364
Q311	8-729-154-83	TRANSISTOR 2SB548
Q312	8-729-612-77	TRANSISTOR 2SA1027R
Q313	8-729-612-77	TRANSISTOR 2SA1027R
Q314	8-729-663-47	TRANSISTOR 2SC1364
Q315	8-729-663-47	TRANSISTOR 2SC1364

ELECTRICAL PARTS

Ref.No.	Part No.	Description
Q316	8-729-612-77	TRANSISTOR 2SA1027R
Q317	8-729-663-47	TRANSISTOR 2SC1364
Q318	8-729-663-47	TRANSISTOR 2SC1364
Q319	8-729-663-47	TRANSISTOR 2SC1364
Q320	8-729-612-77	TRANSISTOR 2SA1027R
Q502	8-729-663-47	(NEW MODEL)...TRANSISTOR 2SC1364
Q503	8-729-178-54	TRANSISTOR 2SC2785
Q504	8-729-178-54	TRANSISTOR 2SC2785
Q505	8-729-117-54	TRANSISTOR 2SA1175
Q506	8-729-117-54	TRANSISTOR 2SA1175
Q507	8-729-117-54	TRANSISTOR 2SA1175
Q508	8-729-117-54	TRANSISTOR 2SA1175
Q509	8-729-178-54	TRANSISTOR 2SC2785
Q550	8-719-902-01	PHOTO INTERRUPTOR SPI201
R182	1-214-966-00	METAL FILM 1.2M 1% 1/4W
R282	1-214-966-00	METAL FILM 1.2M 1% 1/4W
R355	1-217-531-00	FUSIBLE 47 5% 1/4W
RV101	1-226-236-00	RES, ADJ, CARBON 10K
RV102	1-226-236-00	RES, ADJ, CARBON 10K
RV103	1-226-991-00	RES, VAR, SLIDE 20K/20K
RV203	1-226-991-00	RES, VAR, SLIDE 20K/20K
RV201	1-226-236-00	RES, ADJ, CARBON 10K
RV202	1-226-236-00	RES, ADJ, CARBON 10K
RV401	1-226-236-00	RES, ADJ, CARBON 10K
RV402	1-226-236-00	RES, ADJ, CARBON 10K
RY301	1-515-473-00	RELAY
S301	1-554-209-00	SWITCH, PUSH (4 KEY)
S302		
S303		
S304		
S305	1-553-318-00	(AEP,UK,E).....SWITCH, PUSH (AC POWER)
S305	1-553-319-00	(US,Canadian)...SWITCH, PUSH (AC POWER)
S550	1-554-208-00	SWITCH, SLIDE
S551	1-554-205-00	SWITCH, SLIDE
S552	1-554-205-00	SWITCH, SLIDE
S553	1-554-205-00	SWITCH, SLIDE
S554	1-554-205-00	SWITCH, SLIDE
S560	1-554-210-00	SWITCH, PUSH
S561	1-554-210-00	SWITCH, PUSH
S562	1-554-210-00	SWITCH, PUSH
S563	1-554-210-00	SWITCH, PUSH
S564	1-554-210-00	SWITCH, PUSH
S565	1-554-210-00	SWITCH, PUSH
S566	1-554-210-00	SWITCH, PUSH
T301	1-433-242-00	TRANSFORMER, BIAS OSCILLATOR

NOTE:

- Items with no part number and no description are not stocked because they are seldom required for routine service.
- Items marked "▲" are not stocked since they are seldom required for routine service. Some delay should be anticipated when ordering these items.
- Due to standardization, parts with part numbers (Δ-ΔΔΔ-ΔΔΔ-XX or Δ-ΔΔΔΔ-ΔΔΔ-X) may be different from those used in the set.

CAPACITORS:

- All capacitors are in μF. Common capacitor values are omitted. Refer to the following lists for their part numbers. MF:μF, PF:μμF.

RESISTORS

- All resistors are in ohms. Common 1/4W, 1/8W and 1/16W carbon resistors are omitted. Refer to the following lists for their part numbers.

- F : nonflammable

COILS

- MMH : mH, UH : μH

The components identified by shading and mark ▲ are critical for safety. Replace only with part number specified.

Les composants identifiés par une trame et une marque ▲ sont critiques pour la sécurité. Ne les remplacer que par une pièce portant le numéro spécifié.

SEMICONDUCTORS

In each case, U : μ, for example: UA... : μA..., UPA... : μPA..., UPC... : μPC, UPD... : μPD...

NOTE:

- Items with no part number and no description are not stocked because they are seldom required for routine service.
- Items marked "▲" are not stocked since they are seldom required for routine service. Some delay should be anticipated when ordering these items.
- Due to standardization, parts with part numbers (Δ-ΔΔΔ-ΔΔΔ-XX or Δ-ΔΔΔΔ-ΔΔΔ-X) may be different from those used in the set.

CAPACITORS:

- All capacitors are in μF. Common capacitor values are omitted. Refer to the following lists for their part numbers. MF:μF, PF:μμF.

RESISTORS

- All resistors are in ohms. Common 1/4W, 1/8W and 1/16W carbon resistors are omitted. Refer to the following lists for their part numbers.

- F : nonflammable

COILS

- MMH : mH, UH : μH

The components identified by shading and mark ▲ are critical for safety. Replace only with part number specified.

Les composants identifiés par une trame et une marque ▲ sont critiques pour la sécurité. Ne les remplacer que par une pièce portant le numéro spécifié.

SEMICONDUCTORS

In each case, U : μ, for example: UA... : μA..., UPA... : μPA..., UPC... : μPC, UPD... : μPD...

1/4 WATT CARBON RESISTORS

Ω	Part No.	Ω	Part No.	Ω	Part No.	Ω	Part No.	Ω	Part No.	Ω	Part No.	Ω	Part No.
1.0	1-246-401-00	10	1-246-425-00	100	1-246-449-00	1.0k	1-246-473-00	10k	1-246-497-00	100k	1-246-521-00	1.0M	1-246-545-00
1.1	1-246-402-00	11	1-246-426-00	110	1-246-450-00	1.1k	1-246-474-00	11k	1-246-498-00	110k	1-246-522-00	1.1M	1-210-814-00
1.2	1-246-403-00	12	1-246-427-00	120	1-246-451-00	1.2k	1-246-475-00	12k	1-246-499-00	120k	1-246-523-00	1.2M	1-210-815-00
1.3	1-246-404-00	13	1-246-428-00	130	1-246-452-00	1.3k	1-246-476-00	13k	1-246-500-00	130k	1-246-524-00	1.3M	1-210-816-00
1.5	1-246-405-00	15	1-246-429-00	150	1-246-453-00	1.5k	1-246-477-00	15k	1-246-501-00	150k	1-246-525-00	1.5M	1-210-817-00
1.6	1-246-406-00	16	1-246-430-00	160	1-246-454-00	1.6k	1-246-478-00	16k	1-246-502-00	160k	1-246-526-00	1.6M	1-210-818-00
1.8	1-246-407-00	18	1-246-431-00	180	1-246-455-00	1.8k	1-246-479-00	18k	1-246-503-00	180k	1-246-527-00	1.8M	1-210-819-00
2.0	1-246-408-00	20	1-246-432-00	200	1-246-456-00	2.0k	1-246-480-00	20k	1-246-504-00	200k	1-246-528-00	2.0M	1-210-820-00
2.2	1-246-409-00	22	1-246-433-00	220	1-246-457-00	2.2k	1-246-481-00	22k	1-246-505-00	220k	1-246-529-00	2.2M	1-210-821-00
2.4	1-246-410-00	24	1-246-434-00	240	1-246-458-00	2.4k	1-246-482-00	24k	1-246-506-00	240k	1-246-530-00	2.4M	1-244-754-00
2.7	1-246-411-00	27	1-246-435-00	270	1-246-459-00	2.7k	1-246-483-00	27k	1-246-507-00	270k	1-246-531-00	2.7M	1-244-755-00
3.0	1-246-412-00	30	1-246-436-00	300	1-246-460-00	3.0k	1-246-484-00	30k	1-246-508-00	300k	1-246-532-00	3.0M	1-244-756-00
3.3	1-246-413-00	33	1-246-437-00	330	1-246-461-00	3.3k	1-246-485-00	33k	1-246-509-00	330k	1-246-533-00	3.3M	1-244-757-00
3.6	1-246-414-00	36	1-246-438-00	360	1-246-462-00	3.6k	1-246-486-00	36k	1-246-510-00	360k	1-246-534-00	3.6M	1-244-758-00
3.9	1-246-415-00	39	1-246-439-00	390	1-246-463-00	3.9k	1-246-487-00	39k	1-246-511-00	390k	1-246-535-00	3.9M	1-244-759-00
4.3	1-246-416-00	43	1-246-440-00	430	1-246-464-00	4.3k	1-246-488-00	43k	1-246-512-00	430k	1-246-536-00	4.3M	1-244-760-00
4.7	1-246-417-00	47	1-246-441-00	470	1-246-465-00	4.7k	1-246-489-00	47k	1-246-513-00	470k	1-246-537-00	4.7M	1-244-761-00
5.1	1-246-418-00	51	1-246-442-00	510	1-246-466-00	5.1k	1-246-490-00	51k	1-246-514-00	510k	1-246-538-00	5.1M	1-244-762-00
5.6	1-246-419-00	56	1-246-443-00	560	1-246-467-00	5.6k	1-246-491-00	56k	1-246-515-00	560k	1-246-539-00		
6.2	1-246-420-00	62	1-246-444-00	620	1-246-468-00	6.2k	1-246-492-00	62k	1-246-516-00	620k	1-246-540-00		
6.8	1-246-421-00	68	1-246-445-00	680	1-246-469-00	6.8k	1-246-493-00	68k	1-246-517-00	680k	1-246-541-00		
7.5	1-246-422-00	75	1-246-446-00	750	1-246-470-00	7.5k	1-246-494-00	75k	1-246-518-00	750k	1-246-542-00		
8.2	1-246-423-00	82	1-246-447-00	820	1-246-471-00	8.2k	1-246-495-00	82k	1-246-519-00	820k	1-246-543-00		
9.1	1-246-424-00	91	1-246-448-00	910	1-246-472-00	9.1k	1-246-496-00	91k	1-246-520-00	910k	1-246-544-00		

1/8 WATT CARBON RESISTOR

Ω	Part No.	Ω	Part No.	Ω	Part No.	Ω	Part No.	Ω	Part No.	Ω	Part No.	Ω	Part No.
2.0	—	13	1-246-821-00	91	1-246-831-00	620	1-246-841-00	4.3k	1-246-851-00	30k	1-246-861-00	200k	1-246-871-00
2.2	1-246-751-00	15	1-246-761-00	100	1-246-771-00	680	1-246-781-00	4.7k	1-246-791-00	33k	1-246-801-00	220k	1-246-811-00
2.4	—	16	1-246-822-00	110	1-246-832-00	750	1-246-842-00	5.1k	1-246-852-00	36k	1-246-862-00	240k	1-247-054-00
2.7	1-246-752-00	18	1-246-762-00	120	1-246-772-00	820	1-246-782-00	5.6k	1-246-792-00	39k	1-246-802-00	270k	1-247-046-00
3.0	—	20	1-246-823-00	130	1-246-833-00	910	1-246-843-00	6.2k	1-246-853-00	43k	1-246-863-00	300k	1-247-055-00
3.3	1-246-753-00	22	1-246-763-00	150	1-246-773-00	1.0k	1-246-783-00	6.8k	1-246-793-00	47k	1-246-803-00	330k	1-247-047-00
3.6	—	24	1-246-824-00	160	1-246-834-00	1.1k	1-246-844-00	7.5k	1-246-854-00	51k	1-246-864-00	360k	1-247-056-00
3.9	1-246-754-00	27	1-246-764-00	180	1-246-774-00	1.2k	1-246-784-00	8.2k	1-246-794-00	56k	1-246-804-00	390k	1-247-048-00
4.3	—	30	1-246-825-00	200	1-246-835-00	1.3k	1-246-845-00	9.1k	1-246-855-00	62k	1-246-865-00	430k	1-247-057-00
4.7	1-246-755-00	33	1-246-765-00	220	1-246-775-00	1.5k	1-246-785-00	10k	1-246-795-00	68k	1-246-805-00	470k	1-247-049-00
5.1	—	36	1-246-826-00	240	1-246-836-00	1.6k	1-246-846-00	11k	1-246-856-00	75k	1-246-866-00	510k	1-247-058-00
5.6	1-246-756-00	39	1-246-766-00	270	1-246-776-00	1.8k	1-246-786-00	12k	1-246-796-00	82k	1-246-806-00	560k	1-247-050-00
6.2	—	43	1-246-827-00	300	1-246-837-00	2.0k	1-246-847-00	13k	1-246-857-00	91k	1-246-867-00	620k	1-247-059-00
6.8	1-246-757-00	47	1-246-767-00	330	1-246-777-00	2.2k	1-246-787-00	15k	1-246-797-00	100k	1-246-807-00	680k	1-247-051-00
7.5	1-246-818-00	51	1-246-828-00	360	1-246-838-00	2.4k	1-246-848-00	16k	1-246-858-00	110k	1-246-868-00	750k	1-247-060-00
8.2	1-246-758-00	56	1-246-768-00	390	1-246-778-00	2.7k	1-246-788-00	18k	1-246-798-00	120k	1-246-808-00	820k	1-247-052-00
9.1	1-246-819-00	62	1-246-829-00	430	1-246-839-00	3.0k	1-246-849-00	20k	1-246-859-00	130k	1-246-869-00	910k	1-247-061-00
10	1-246-759-00	68	1-246-769-00	470	1-246-779-00	3.3k	1-246-789-00	22k	1-246-799-00	150k	1-246-809-00	1M	1-247-053-00
11	1-246-820-00	75	1-246-830-00	510	1-246-840-00	3.6k	1-246-850-00	24k	1-246-860-00	160k	1-246-870-00		
12	1-246-760-00	82	1-246-770-00	560	1-246-780-00	3.9k	1-246-790-00	27k	1-246-800-00	180k	1-246-810-00		