

TC-H1700

SERVICE MANUAL

Canadian Model
AEP Model
UK Model
E Model
Australian Model
East European Model



This set is the deck section
in MHC-H1700, FH-E656.

Model Name Using Similar Mechanism	TC-WR520/WR520S	
Tape Transport Mechanism Type	DECK A	TCM-190RA12AS
	DECK B	TCM-190RB22A

SPECIFICATIONS

Recording system	4-track 2-channel stereo
Frequency response (DOLBY NR OFF)	40 — 13,000 Hz (± 3 dB) using TYPE I cassette (Sony HF-S)
	40 — 14,000 Hz (± 3 dB) using TYPE II cassette
	40 — 15,000 Hz (± 3 dB) Using TYPE IV cassette (For U.S.A. and Canada, Sony METAL-SLT. For Europe, U.K., and other countries, Sony METAL-S)
Wow and flutter	0.1% WRMS $\pm 0.3\%$ (DIN)
Dimensions	Approx. 225 x 125 x 230 mm (w/h/d) (8 $\frac{7}{8}$ x 5 x 9 $\frac{1}{8}$ inches) incl. projecting parts and controls
Weight	Approx. 2.5 kg (5 lb 8 oz)

Design and specifications subject to change
without notice.

Dolby noise reduction manufactured under license
from Dolby Laboratories Licensing Corporation.
"DOLBY" and the double-D symbol $\square\square$ are trademarks
of Dolby Laboratories Licensing Corporation.

SAFETY-RELATED COMPONENT WARNING!!

COMPONENTS IDENTIFIED BY MARK \triangle OR DOTTED LINE
WITH MARK \triangle ON THE SCHEMATIC DIAGRAMS AND IN
THE PARTS LIST ARE CRITICAL TO SAFE OPERATION. REPLACE
THESE COMPONENTS WITH SONY PARTS WHOSE PART
NUMBERS APPEAR AS SHOWN IN THIS MANUAL OR IN
SUPPLEMENTS PUBLISHED BY SONY.

ATTENTION AU COMPOSANT AYANT RAPPORT À LA SÉCURITÉ!

LES COMPOSANTS IDENTIFIÉS PAR UNE MARQUE \triangle SUR
LES DIAGRAMMES SCHÉMATIQUES ET LA LISTE DES PIÈCES
SONT CRITIQUES POUR LA SÉCURITÉ DE FONCTIONNE-
MENT. NE REMPLACER CES COMPOSANTS QUE PAR DES
PIÈCES SONY DONT LES NUMÉROS SONT DONNÉS DANS
CE MANUEL OU DANS LES SUPPLÉMENTS PUBLIÉS PAR
SONY.



STEREO CASSETTE DECK
SONY®

TABLE OF CONTENTS

Section	Title	Page
1.	SERVICE NOTE	2
2.	GENERAL	2
3.	DISASSEMBLY	3
4.	ADJUSTMENTS	
4-1.	Mechanical Adjustment	4
4-2.	Electrical Adjustment	4
5.	DIAGRAMS	
5-1.	Block Diagram	9
5-2.	Semiconductor Lead Layouts	12
5-3.	Circuit Boards Location	13
5-4.	Printed Wiring Boards (MD/Power Supply Section) – AEP, UK, G, EE Model –	14
5-5.	Schematic Diagram (MD/Power Supply Section) – AEP, UK, G, EE Model –	17
5-6.	Printed Wiring Boards (MD/Power Supply Section) – Canadian, AUS, E, EA Model –	20
5-7.	Schematic Diagram (MD/Power Supply Section) – Canadian, AUS, E, EA Model –	23
5-8.	Printed Wiring Boards (Main Section) – AEP, UK, G, EE Model –	27
5-9.	Schematic Diagram (Main Section) – AEP, UK, G, EE Model –	29
5-10.	Schematic Diagram (Main Section) – Canadian, AUS, E, EA Model –	33
5-11.	Schematic Diagram (Main Section) – Canadian, AUS, E, EA Model –	38
5-12.	Pin Functions	40
5-13.	Waveforms	44
6.	EXPLODED VIEWS	
6-1.	Chassis Section	45
6-2.	Mechanism Section 1	47
6-3.	Mechanism Section 2	48
7.	ELECTRICAL PARTS LIST	49

NOTE :

- G : Germany model
- AUS : Australian model
- EA : Saudi Arabia model
- EE : East European model

SECTION 1

SERVICING NOTE

SUPPLY OF POWER DURING SERVICES

Because the equipment is not provided with any power supply, it is operated with power supplied from the amplifier HCD-H1700 used. The equipment requires the following 2 types of voltage. Therefore, connect the equipment to HCD-H1700 for services such as repairing with power supplied, because it will be too complicated to supply these voltages individually.

VOLTAGE	MAJOR CIRCUIT IN USE
AC 3V	FL tube filament voltage (VF)
AC 9V	Micro-computer, audio, motor section Vcc

SECTION 2

GENERAL

This section is extracted from instruction manual.

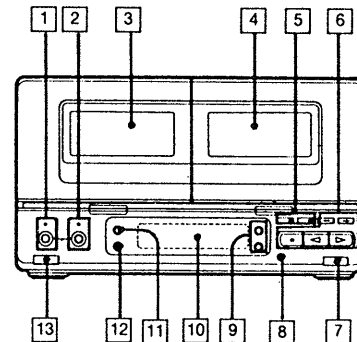

- 1 DUBBING MODE button and indicator
- 2 CD SYNCHRO (CD synchronized recording) button and indicator
- 3 Cassette holder (Deck A)
- 4 Cassette holder (Deck B)
- 5 Tape operation buttons (for Deck B only)
PAUSE ||
REC ● (recording)
- 6 Tape operation buttons (for Deck A and B)
AMS ◀▶▶▶ : Fast winding
■ : Stop
▷ : Forward play
◁ : Reverse play
- 7 △ (eject) button (Deck B)
- 8 DIRECTION MODE button
- 9 DECK A/B selection buttons and indicators
- 10 Display window
- 11 RESET (counter reset) button
- 12 DOLBY NR (Dolby Noise Reduction) button
- 13 △ (eject) button (Deck A)

SECTION 3 DISASSEMBLY

- Remove the following devices shown by ❶, etc. in the order of the numbers.

CASSETTE LID

Remove 2 hooks and remove the cassette lid.

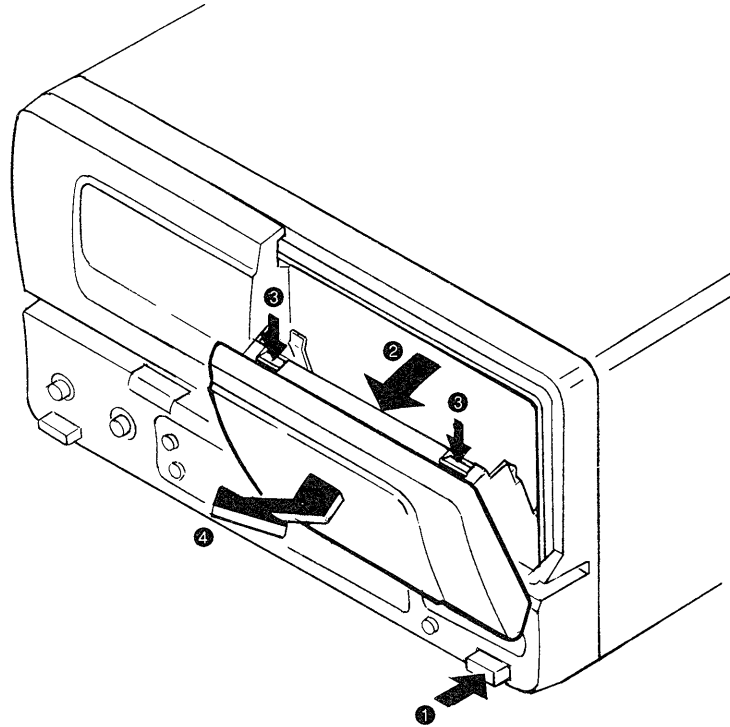

AZIMUTH COVER

After completion of removing the cassette lid, remove the azimuth cover by pushing the hooks toward inside.

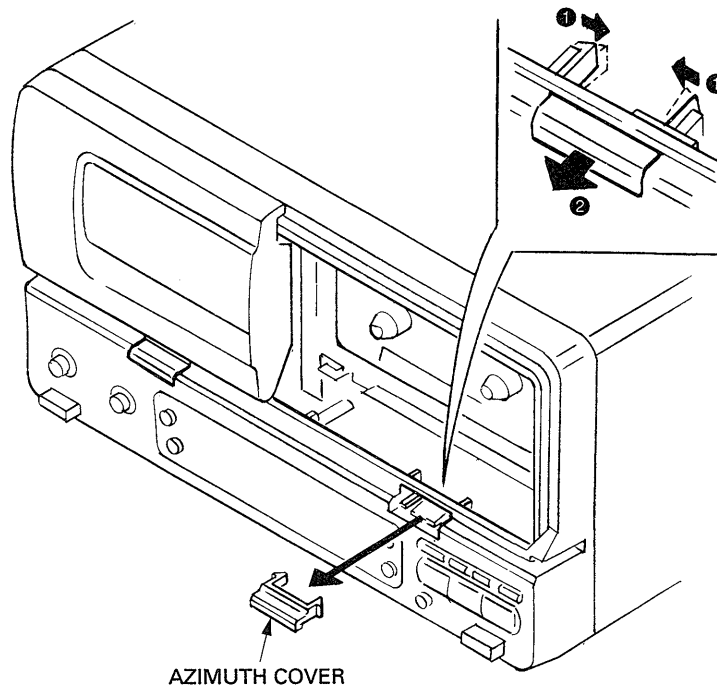

SECTION 4 ADJUSTMENTS

4-1. MECHANICAL ADJUSTMENT

PRECAUTION

1. Clean the following parts with a denatured-alcohol-moistened swab:

record / playback head	pinch roller
erase head	rubber belts
capstan	idler
2. Demagnetize the record / playback head with a head demagnetizer
3. Do not use a magnetized screwdriver for the adjustments.
4. After the adjustments, apply suitable locking compound to the parts adjusted.
5. The adjustments should be performed in the rated power supply voltage unless otherwise noted.

Torque Measurement

Torque	Torque meter	Meter reading
FWD	CQ-102C	35 to 60g•cm (0.49 to 0.83 oz•inch)
FWD Back tension	CQ-102C	2 to 6g•cm (0.028 to 0.08 oz•inch)
REV	CQ-102RC	35 to 60g•cm (0.49 to 0.83 oz•inch)
REV Back tension	CQ-102RC	2 to 6g•cm (0.028 to 0.08 oz•inch)
FF, REW	CQ-201B	70 to 110g•cm (0.98 to 1.52 oz•inch)

4-2. ELECTRICAL ADJUSTMENT

Note : The adjustment should be performed in the order given in the service manual. As a rule, adjustment about playback should be performed before adjustment about recording. The adjustments should be performed for both L-CH and R-CH.

- Switches and controls should be set as follows unless otherwise specified.

DOLBY NR switch	: OFF
DIRECTION MODE switch	: ⇄
- Standard Record :
Deliver the standard input signal level to the input jack and set the REC LEVEL control to obtain the standard output signal level.

– Record Mode –

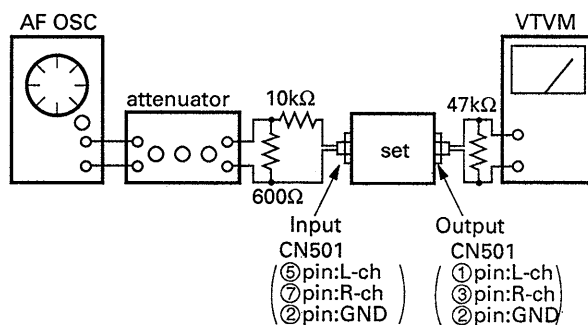

Standard Input Level

input terminal	Input (CN501)
source impedance	10kΩ
input level	0.39V (−6dB)

Standard Output Level

output terminal	Output (CN501)
load impedance	47kΩ
output level	0.39V (−6dB)

Test tape

Type	Signal	Used for
P-4-A100	10kHz, −10dB	Azimuth Adjustment
P-4-L300	315Hz, 0dB	PB Level Adjustment
WS-48B	3kHz, 0dB	Tape Speed Adjustment

Record / Playback Head Azimuth Adjustment

DECK A DECK B

Procedure :

1. Mode : FWD Playback

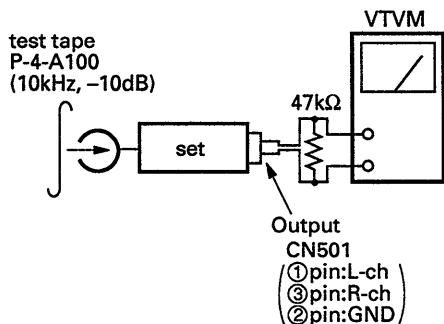

2. Turn the adjustment screw for the maximum output levels. If these levels do not match, turn the adjustment screw until both of output levels match together within 1dB.

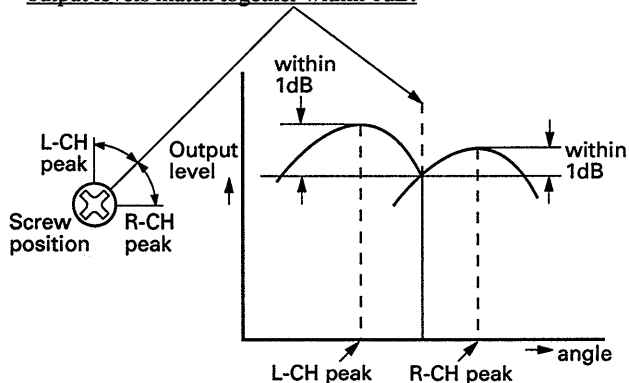

3. Phase Check
Mode : FWD playback

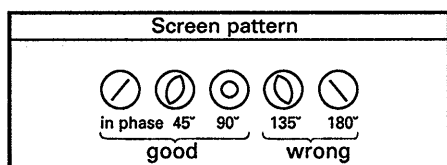
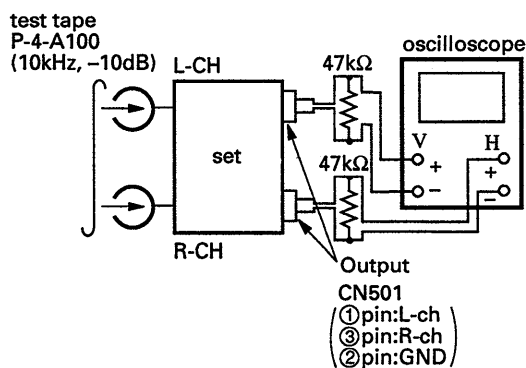

4. Set in the REV mode and repeat the step 1-3.
5. After the adjustment, lock the screws with locking compound.

Adjustment Location : Record / Playback head

- Remove 2 hooks and remove the cassette lid.

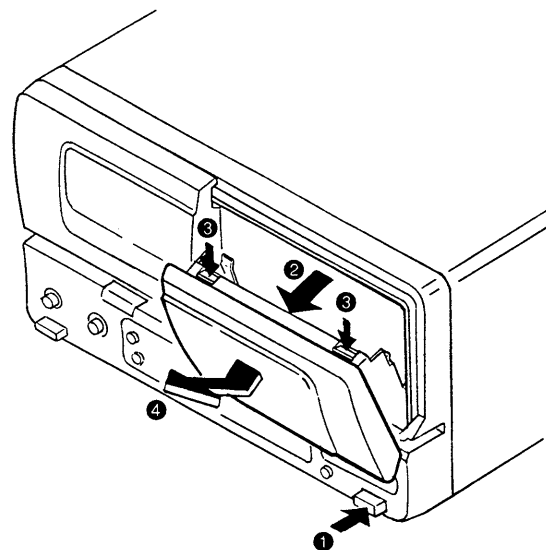

- Remove the azimuth cover by pushing the hooks toward inside.

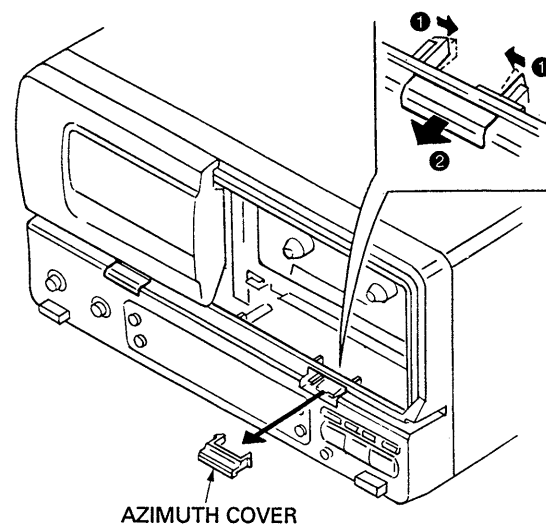

- Azimuth adjustment screw

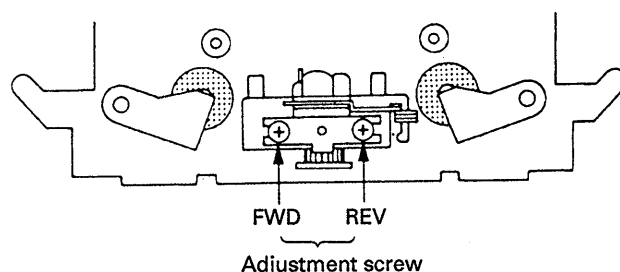

Tape Speed Adjustment

DECK A

DECK B

Perform high speed adjustment before normal speed adjustment

Procedure :

Mode : FWD playback

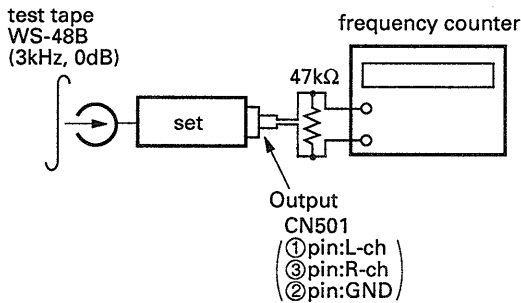

(High speed adjustment)

DECK A

1. Turn ON the power switch with TP601 of the main board shorted.
2. Set a WS-48B tape onto the deck A and press the ▷ switch to activate FWD.
3. Upon beginning FWD, press the S601 of the main board.
4. Confirm that the reading of the frequency counter satisfies $6,000 \pm 30$ Hz.
5. Adjust the RV72 (DECK A) so that the frequency counter reading becomes $6,000 \pm 30$ Hz .
6. Set in the REV mode and repeat the Step 2-5.

(High speed adjustment)

DECK B

1. Turn ON the power switch with TP601 of the main board shorted.
2. Set a WS-48B tape onto the deck B and press the ▷ switch to activate FWD.
3. Upon beginning FWD, press the S601 of the main board.
4. Confirm that the reading of the frequency counter satisfies $6,000 \pm 30$ Hz.
5. Adjust the RV72 (DECK B) so that the frequency counter reading becomes $6,000 \pm 30$ Hz .
6. Set in the REV mode and repeat the Step 2-5.
7. Disconnect the TP601.

Note: POWER ON/OFF switch of the HCD-H1700 is a micro-computer control switch. Therefore, if test mode cannot be actuated, disconnect the power supply plug out of the socket, plug it in again, and then repeat the operation 1.

(Normal speed adjustment)

DECK A

DECK B

1. Set a WS-48B tape onto the deck A.
2. Press the ▷ switch to activate FWD.
3. Confirm that the reading of the frequency counter satisfies $3,000 \pm 15$ Hz.
4. If the above is not satisfied, adjust the RV71 so that the readings of the frequency counter for both decks A and B become $3,000 \pm 15$ Hz.
5. Set in the REV mode and repeat the step 1-4.

Frequency difference between the beginning and the end of the tape should be within 3%.

Frequency difference between deck A and deck B the beginning of the tape should be within 1%.

Adjustment Location : AUDIO board (DECK A),
AUDIO board (DECK B)

DECK B

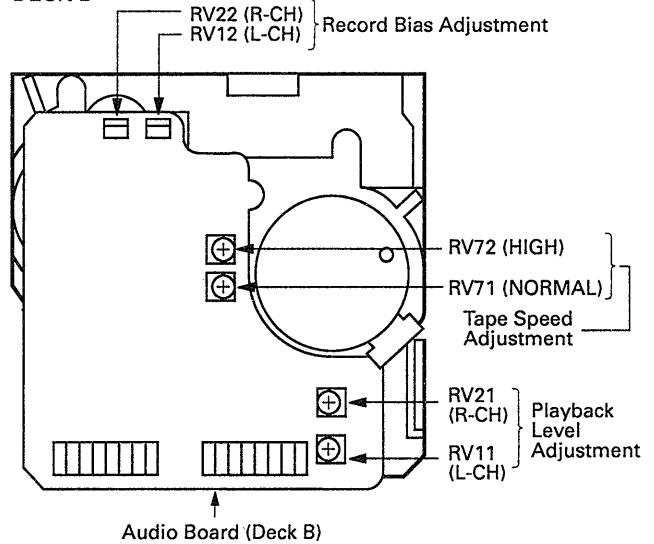

DECK A

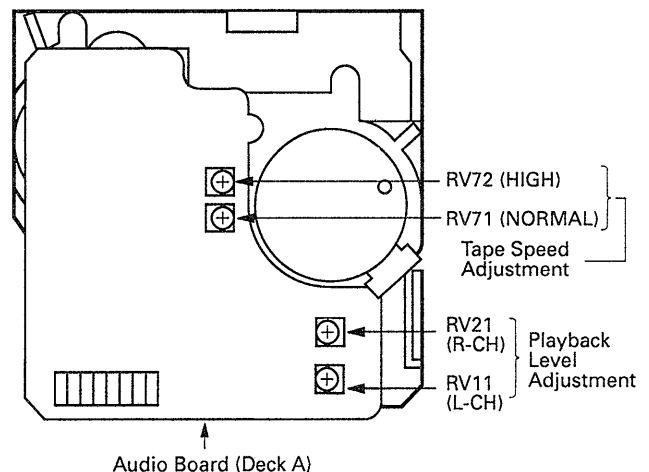

Playback Level Adjustment

DECK A DECK B

Procedure :

Mode : FWD playback

test tape
P-4-L300
(315Hz, 0dB)

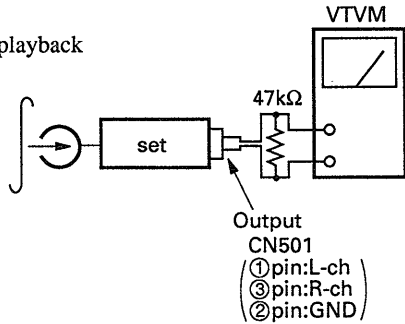

Adjust RV11 (L-CH), RV21 (R-CH) so that the reading on VTVM meets the adjustment limits below.

Adjustment Limits :

Output level : -6 ± 1 dB (0.35-0.44V)

Level difference between channels : less than 1dB

Confirm that the OUTPUT level does not change in playback mode while changing the mode from playback to stop several times.

Adjustment Location : AUDIO board (DECK A),
AUDIO board (DECK B)

DECK B

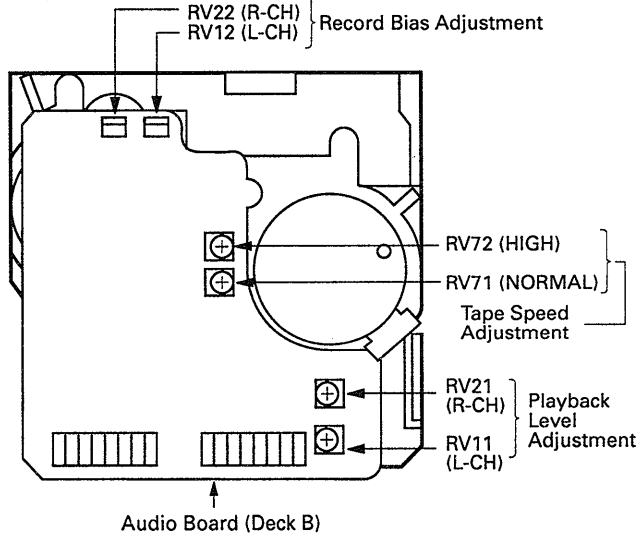

DECK A

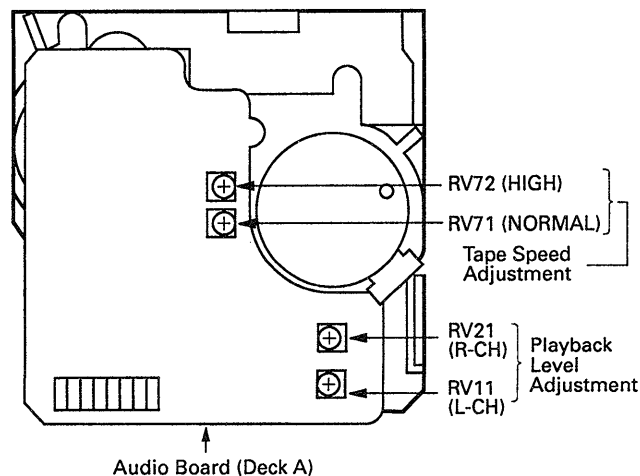

Record Bias Adjustment

DECK B

Setting :

REC LEVEL control : Standard Record (See page 4).

Procedure :

1. Mode : record

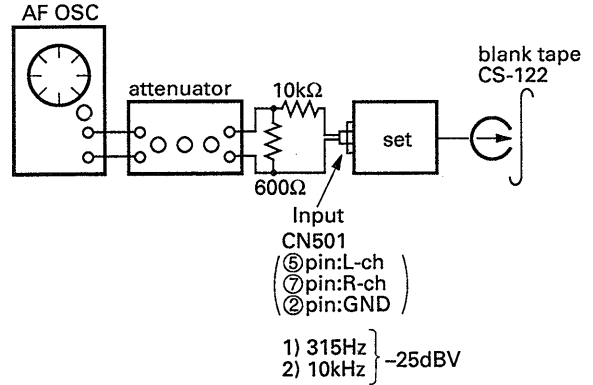

2. Mode : FWD playback

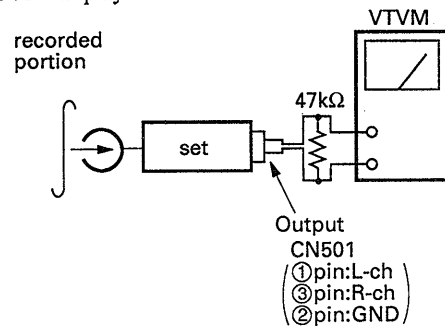

3. Playback the signal recorded in step 1.

Confirm that the 10kHz playback output is 0 ± 0.5 dB relative to the 315Hz output. If necessary, adjust RV12 (L-CH), RV22 (R-CH) and repeat the steps given above.

Adjustment Location : AUDIO board (DECK B)

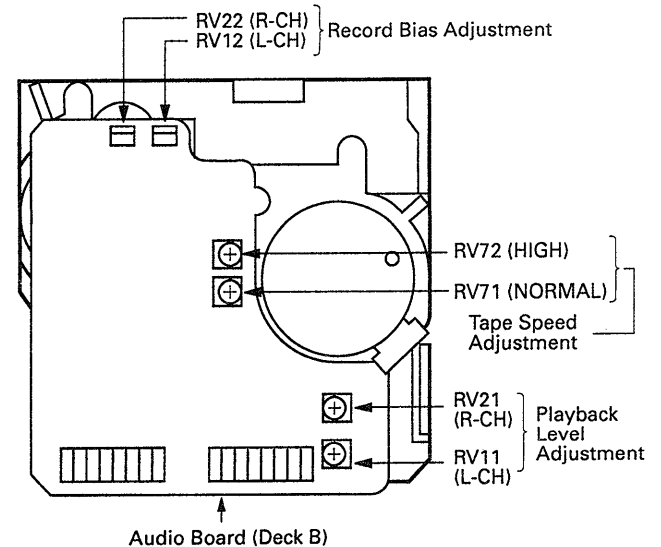

Record Level Adjustment

DECK B

Setting :

REC LEVEL control : Standard Record (See page 4).

Procedure :

1. Mode : record

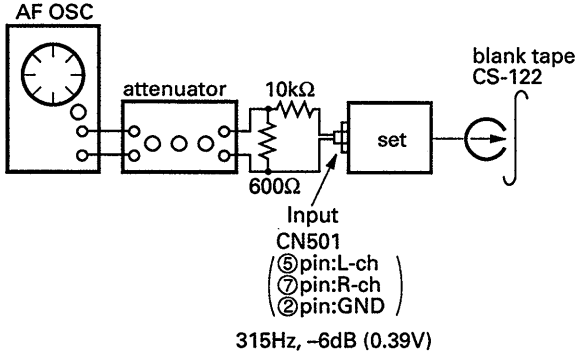

3. Playback the signal recorded in step 1.

Confirm that the signal level is within the adjustment limits below.
If necessary, adjust RV101 (L-CH), RV201 (R-CH) and repeat the steps given above.

Adjustment Limits : -6dB±0.5dB (0.37-0.42V)

2. Mode : FWD playback

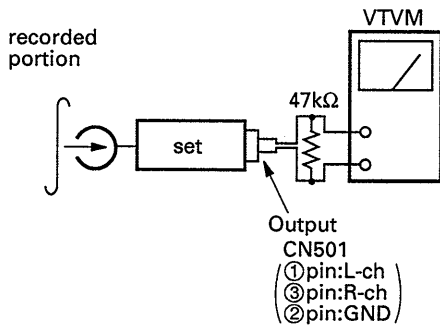

Adjustment Location : MAIN board

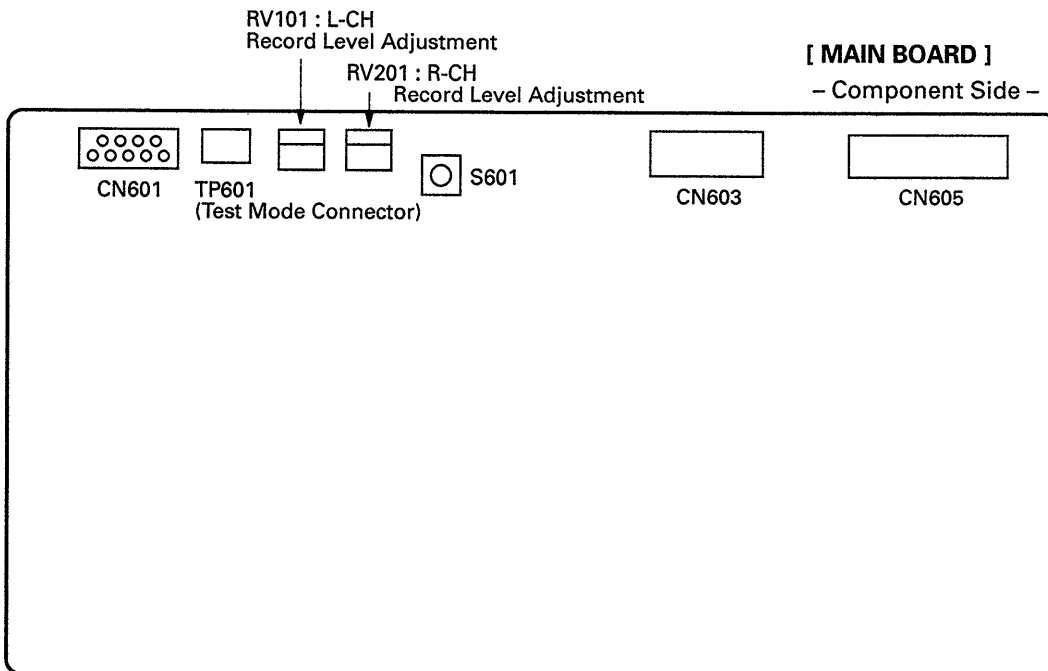

**SECTION 5
DIAGRAMS**

5-1. BLOCK DIAGRAM

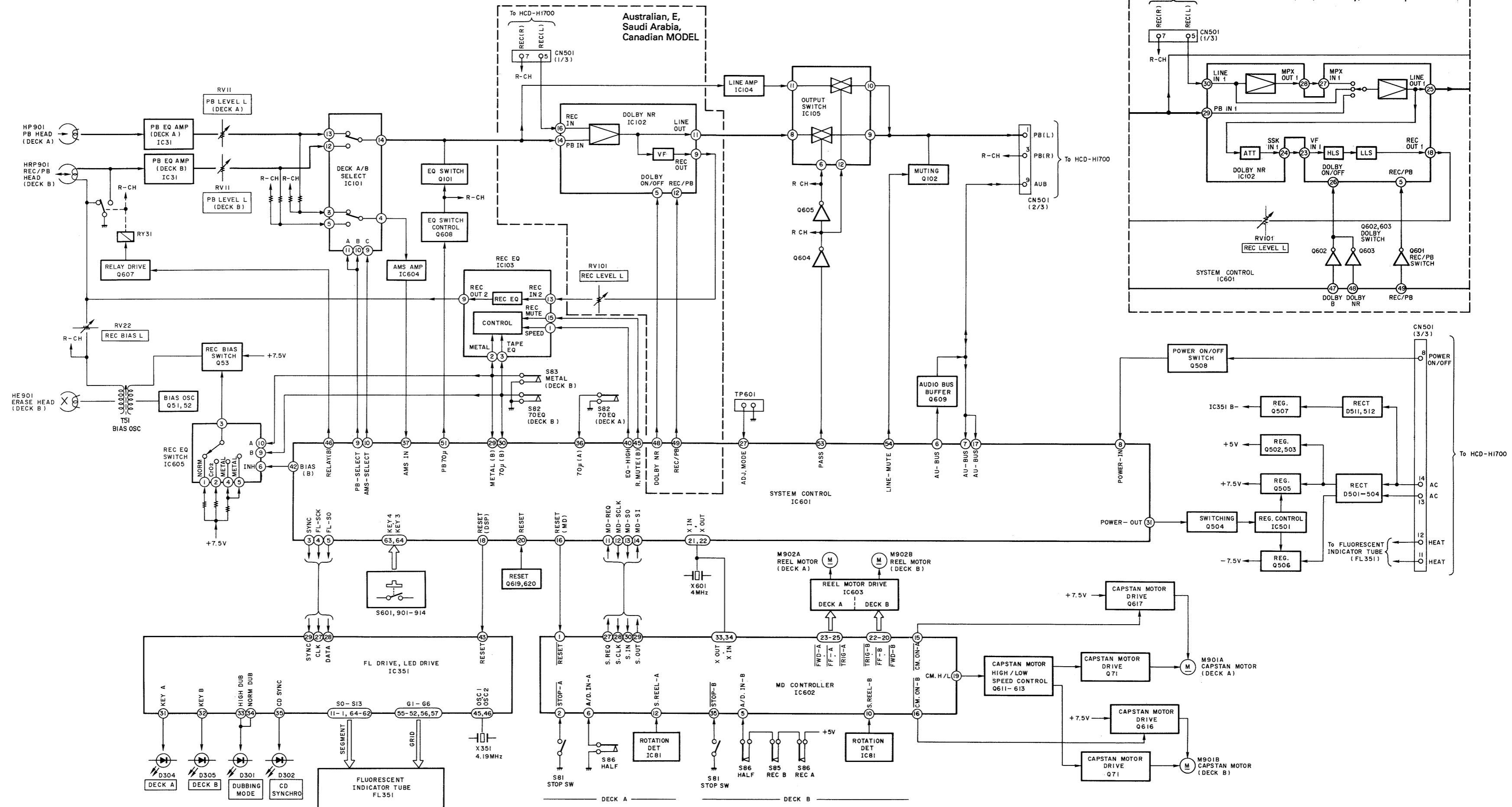

5-2. SEMICONDUCTOR LEAD LAYOUTS

CD4052BCM
CXA1101M
CXA1578M
HD14053BFP

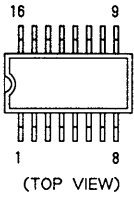

M50944-128FP

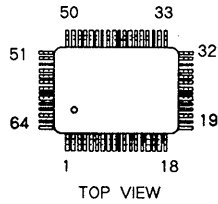

2SA1344

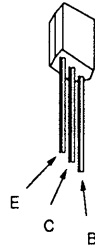

MA153

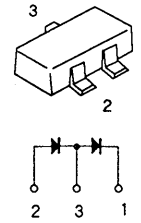

CD4066BCM

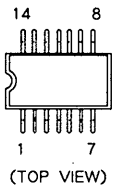

RC4558PS
 μ **PC4570G2**

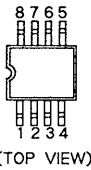

2SB1094-LK
2SD2012

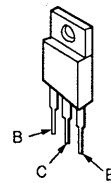

MA3056L
MA3068L
MA3082
MA3091
MA3180

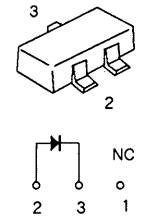

TA7272P

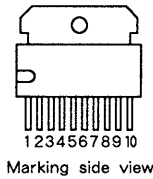

2SB1116A-L

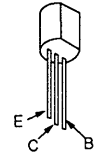

NJL5165K-B

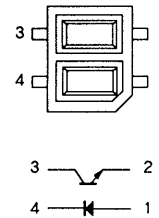

CXA1331M

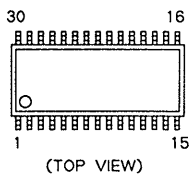

UN2211
2SC1602-F
2SC3397
2SC3900
2SC4154-F

2SB1121-ST
2SD1622-S

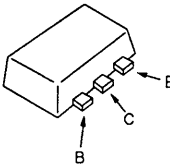

1SS355

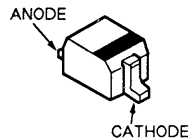

HD614023-FA93

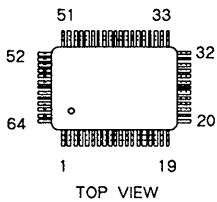

2SA1341

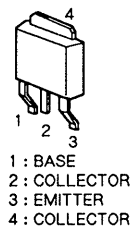

EC10DS2

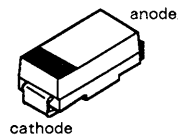

SEL2210S-C

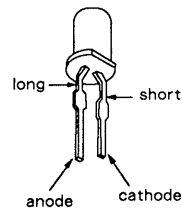

M50925-482FP

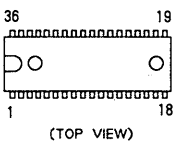

MA152WK

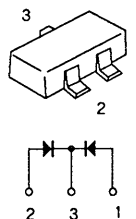

5-3. CIRCUIT BOARDS LOCATION

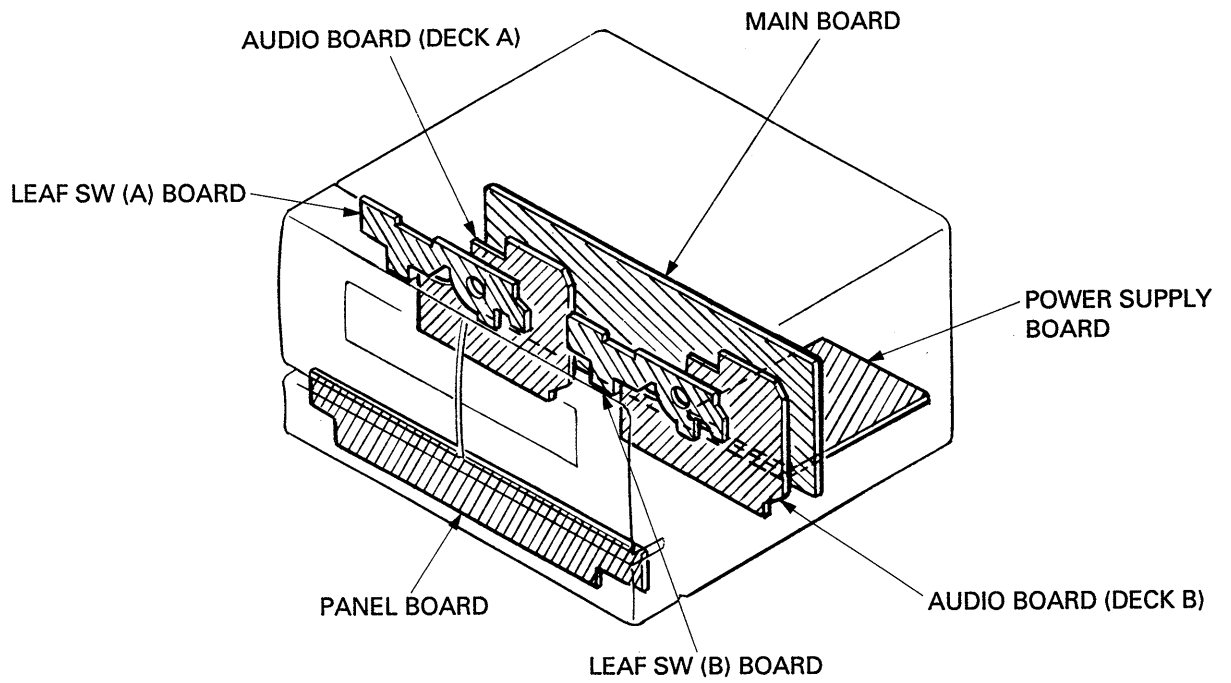

● SEMICONDUCTOR LOCATION

(MD/POWER SUPPLY SECTION)

- AEP, UK, Germany, East European Model -

(AUDIO BOARD (DECK A),
LEAF SW (A) BOARD)

Ref. No.	Location
IC31	G-2
IC81	B-4
Q71	G-4

(AUDIO BOARD (DECK B),
LEAF SW (B) BOARD)

Ref. No.	Location
D31	G-7
IC31	G-8
IC81	B-10
Q51	E-8
Q52	E-8
Q53	F-8
Q71	G-11

(POWER SUPPLY BOARD)

Ref. No.	Location	Ref. No.	Location
D501	F-16	D515	F-15
D502	F-15	D516	F-15
D503	F-16	D517	F-16
D504	F-16		
D505	F-15	IC501	E-14
D506	F-16	Q502	E-17
D507	G-15	Q503	E-16
D508	E-16	Q504	E-16
D509	E-16	Q505	E-15
D510	E-14	Q506	E-14
D511	H-16	Q507	I-16
D512	H-16	Q508	G-15
D513	H-16		
D514	F-16		

- Notes on printed wiring boards:
- : Indicated a lead wire mounted on the component side
 - : Parts mounted on the conductor side
 - : Through hole
 - ▨ : Pattern from the side which enables seeing
 - ⋯ : Pattern of the rear side

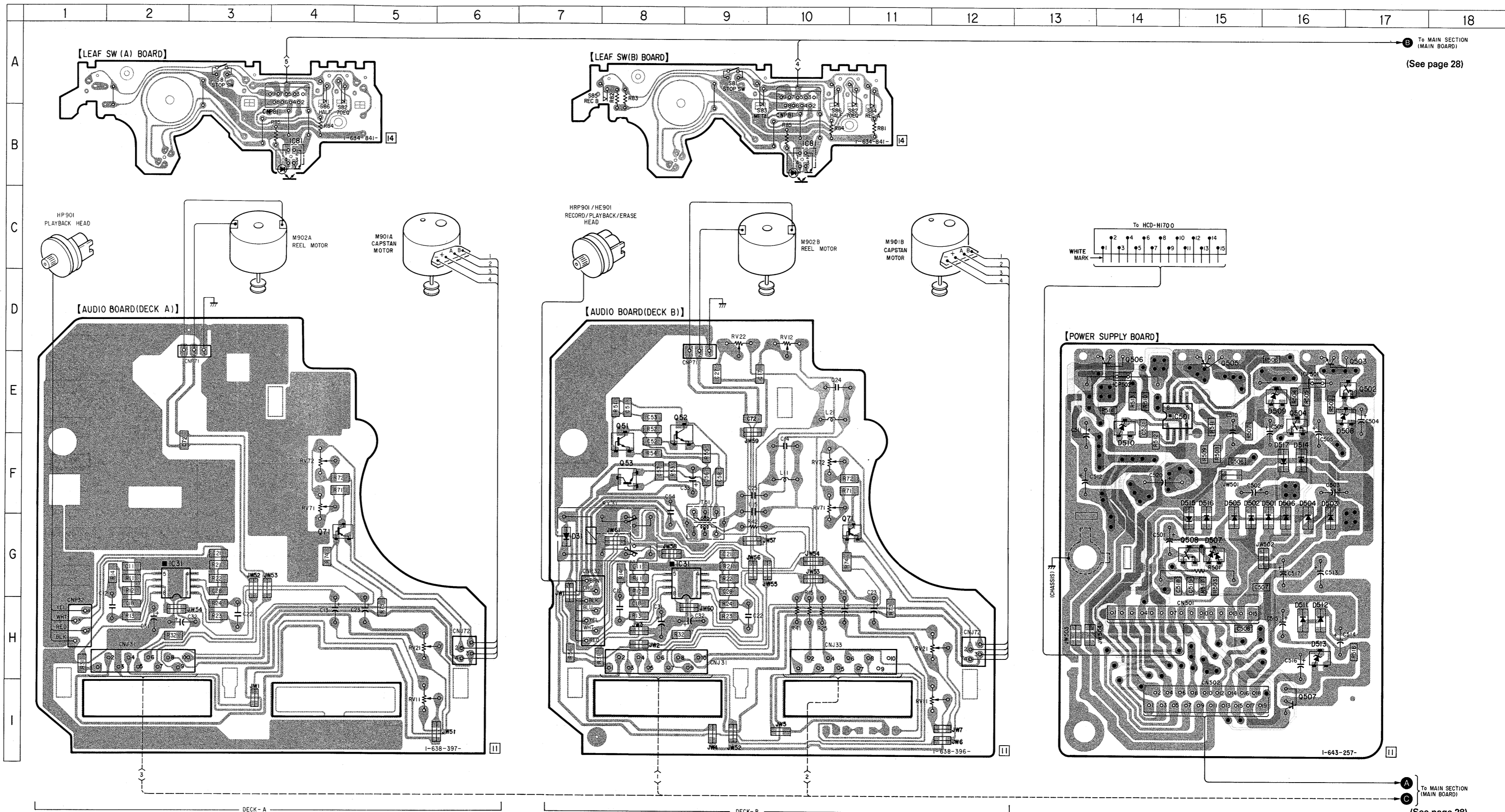

To MAIN SECTION (MAIN BOARD)
(See page 28)

To MAIN SECTION (MAIN BOARD)
(See page 28)

1	2	3	4	5	6	7	8	9	10	11	12	13	14	15	16	17	18
---	---	---	---	---	---	---	---	---	----	----	----	----	----	----	----	----	----

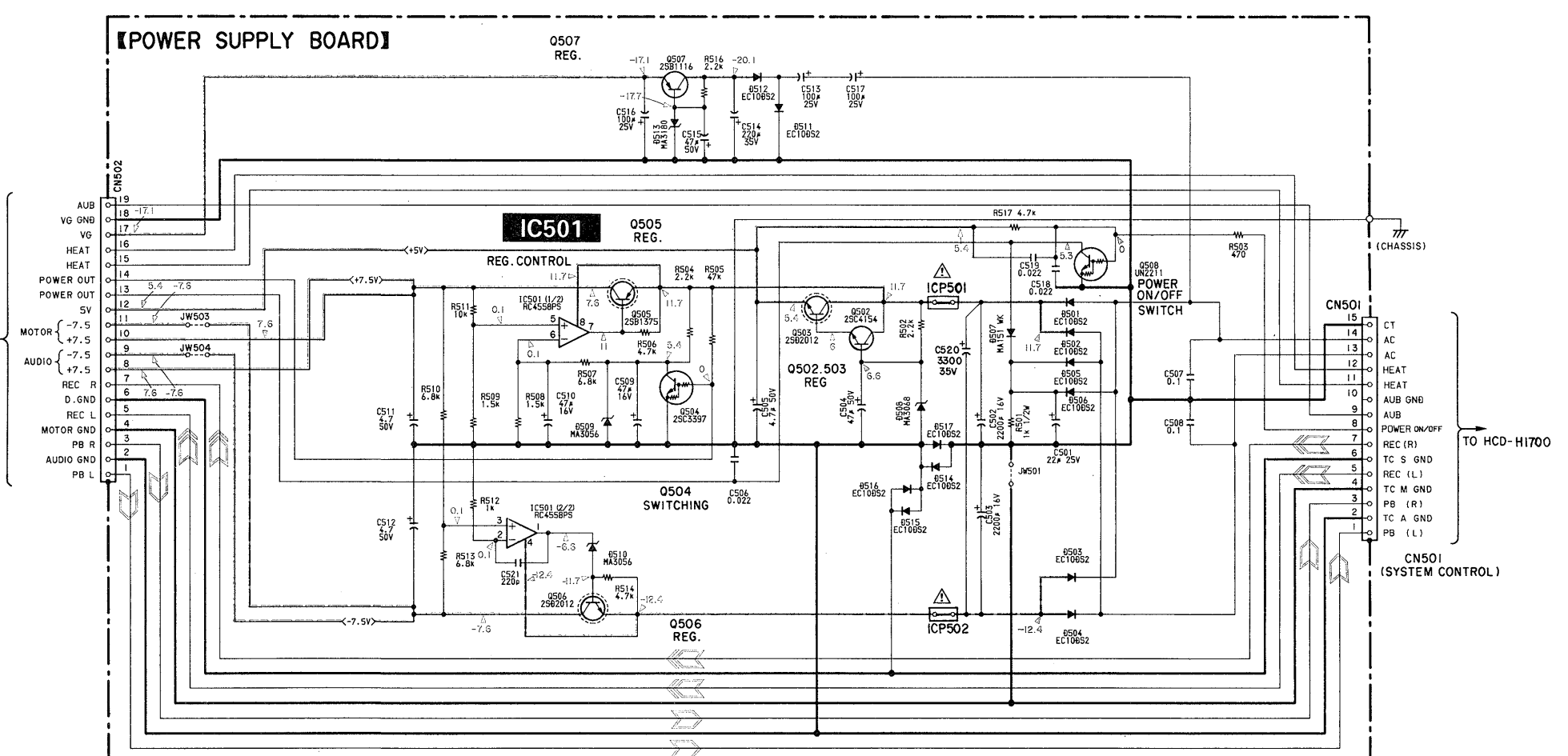
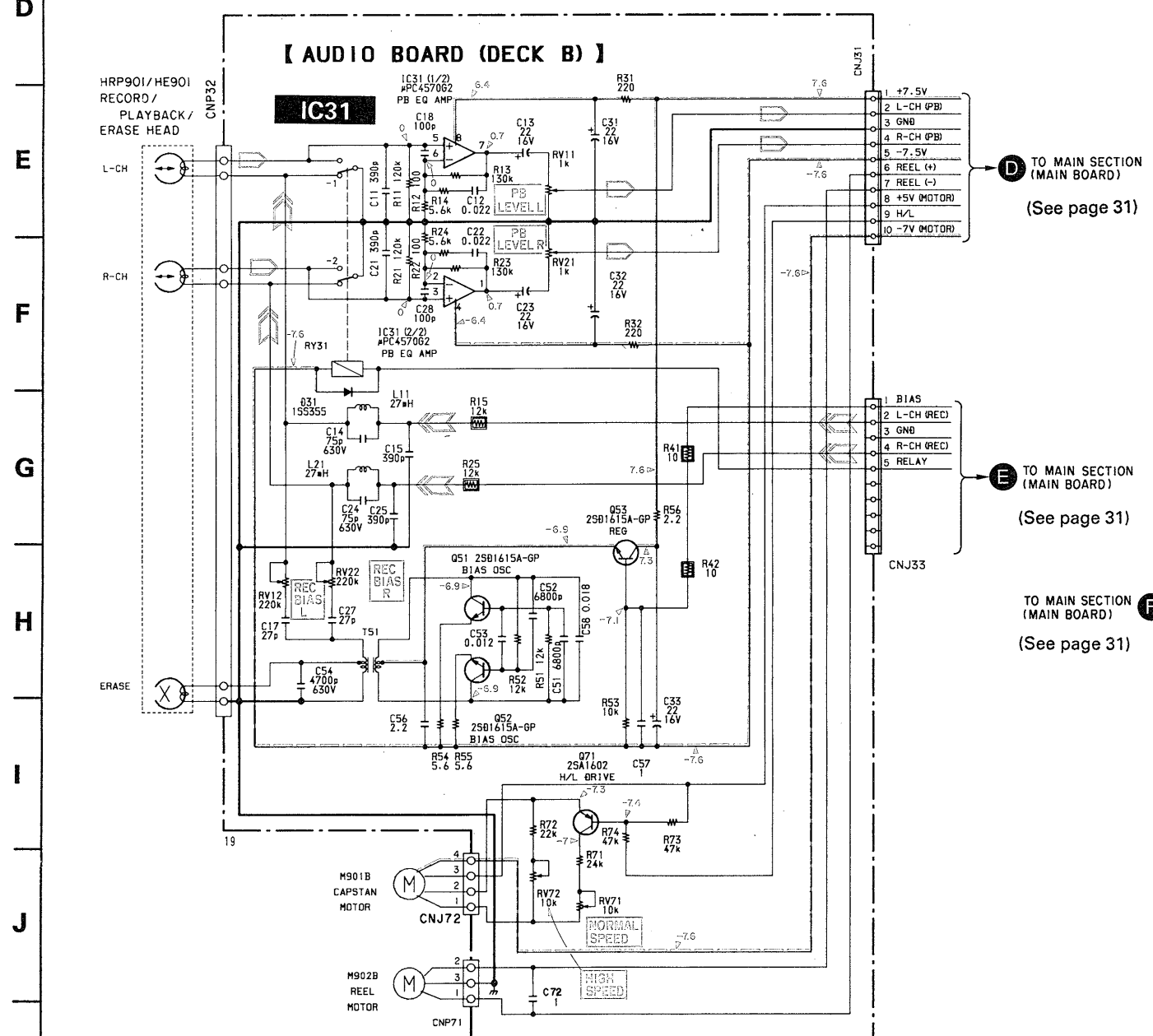
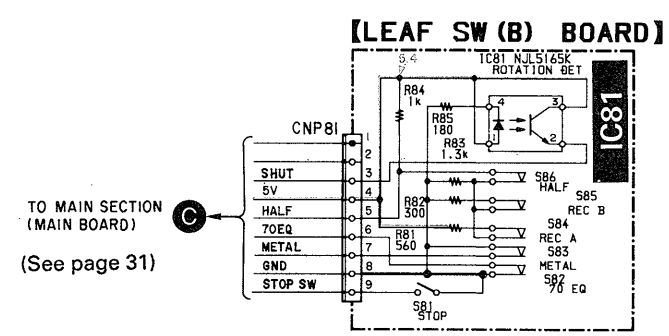
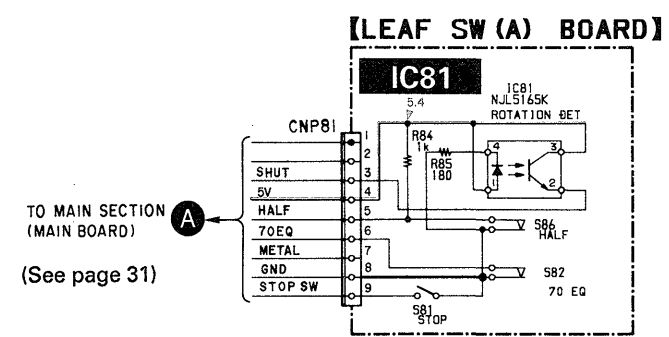
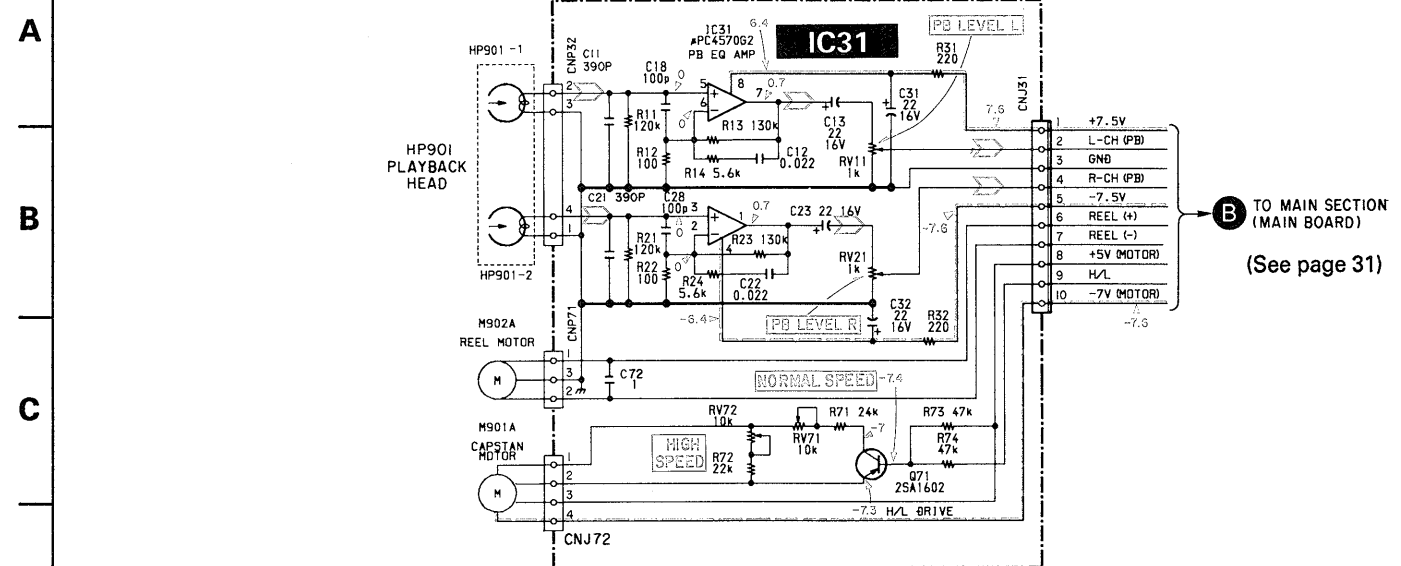

Notes on schematic diagram:

- All capacitors are in μF unless otherwise noted. pF: μF 50WV or less are not indicated except for electrolytics and tantalums.
- All resistors are in ohms, 1/4W or less unless otherwise noted.
- Δ : Fuse resistor

The components identified by mark Δ or dotted line with mark Δ are critical for safety. Replace only with part number specified.

Les composants identifiés par une marque Δ sont critiques pour la sécurité. Ne les remplacer que par une pièce portant le numéro spécifié.

- : B+ Line
- - - - -: B- Line
- : Adjustment for repair
- Voltage are dc with respect to ground under no-signal conditions.
- No mark : PLAY
- { } : REC
- Voltages are taken with a VOMi (input impedance 10M Ω). Voltage variations may be noted due to normal production tolerances.
- Signal path
- ▶ : PLAY (DECK A)
- ◀ : PLAY (DECK B)
- ◀▶ : REC (DECK B)

● SEMICONDUCTOR LOCATION

- Canadian, Australian, E, Saudi Arabia Model -

(AUDIO BOARD (DECK A),
LEAF SW (A) BOARD)

Ref. No.	Location
IC31	G-2
IC81	B-4
Q71	G-4

(AUDIO BOARD (DECK B),
LEAF SW (B) BOARD)

Ref. No.	Location
D31	G-7
IC31	G-8
IC81	B-10
Q51	E-8
Q52	E-8
Q53	F-8
Q71	G-11

(POWER SUPPLY BOARD)

Ref. No.	Location	Ref. No.	Location
D501	F-16	D515	F-15
D502	F-15	D516	F-15
D503	F-16	D517	F-16
D504	F-16		
D505	F-15	IC501	E-14
D506	F-16	Q502	E-17
D507	G-15	Q503	E-16
D508	E-16	Q504	E-16
D509	E-16	Q505	E-15
D510	E-14	Q506	E-14
D511	H-16	Q507	I-16
D512	H-16	Q508	G-15
D513	H-16		
D514	F-16		

- Notes on printed wiring boards:
- : Indicated a lead wire mounted on the component side
 - : Parts mounted on the conductor side
 - : Through hole
 - ▨ : Pattern from the side which enables seeing
 - ▩ : Pattern of the rear side

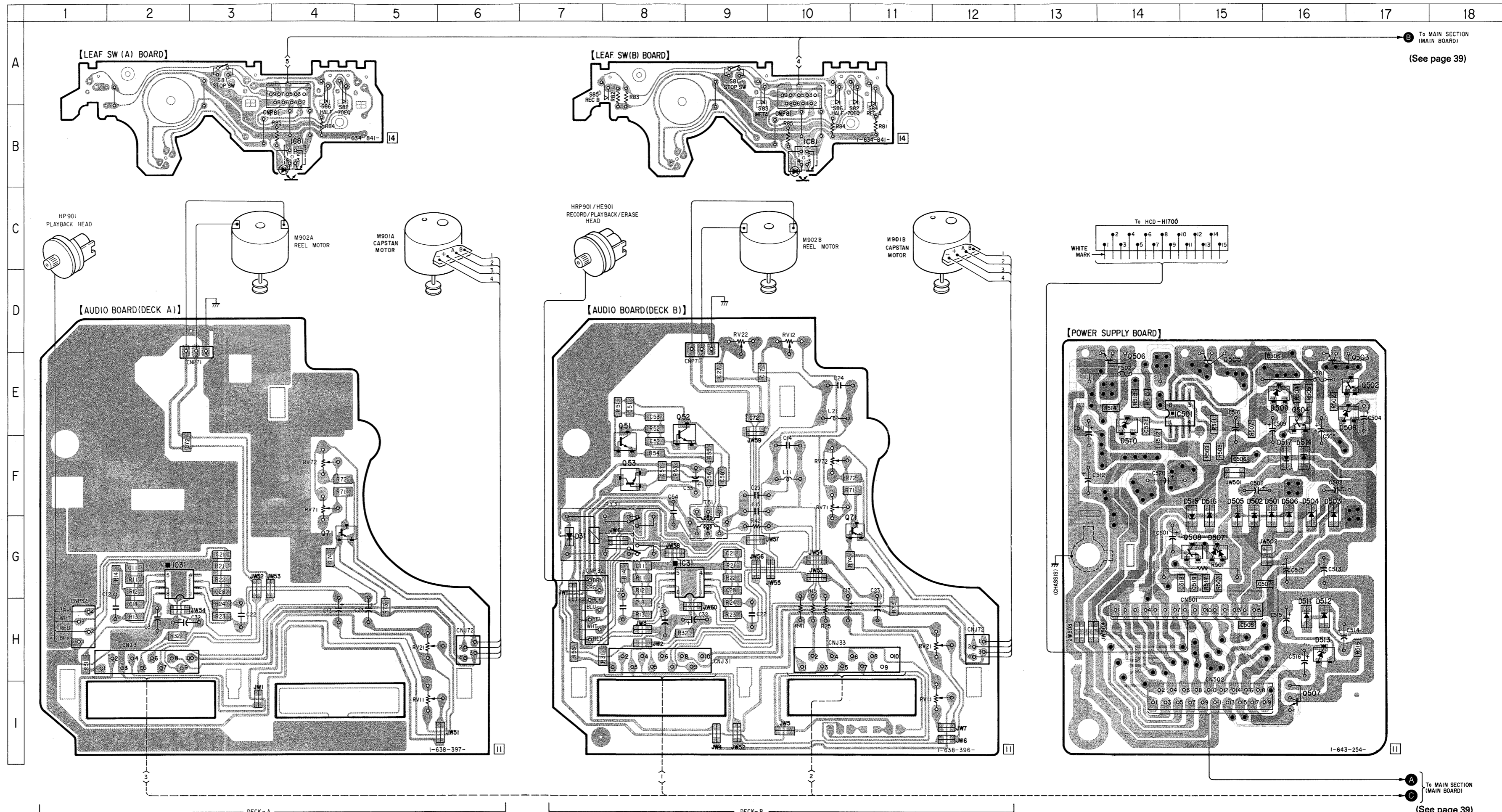

1 2 3 4 5 6 7 8 9 10 11 12 13 14 15 16 17 18

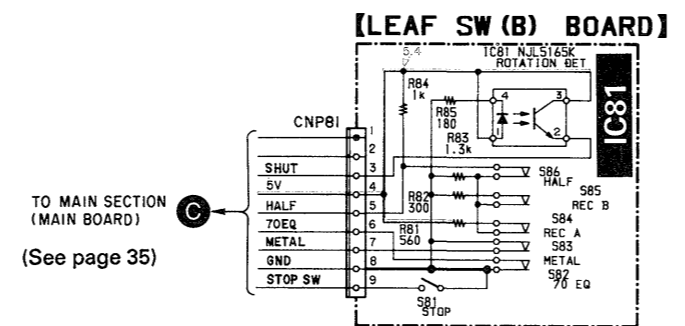
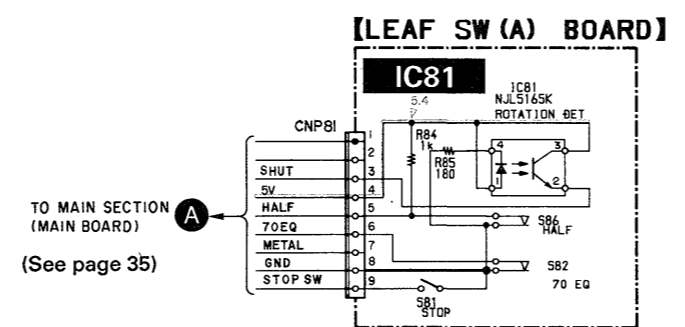
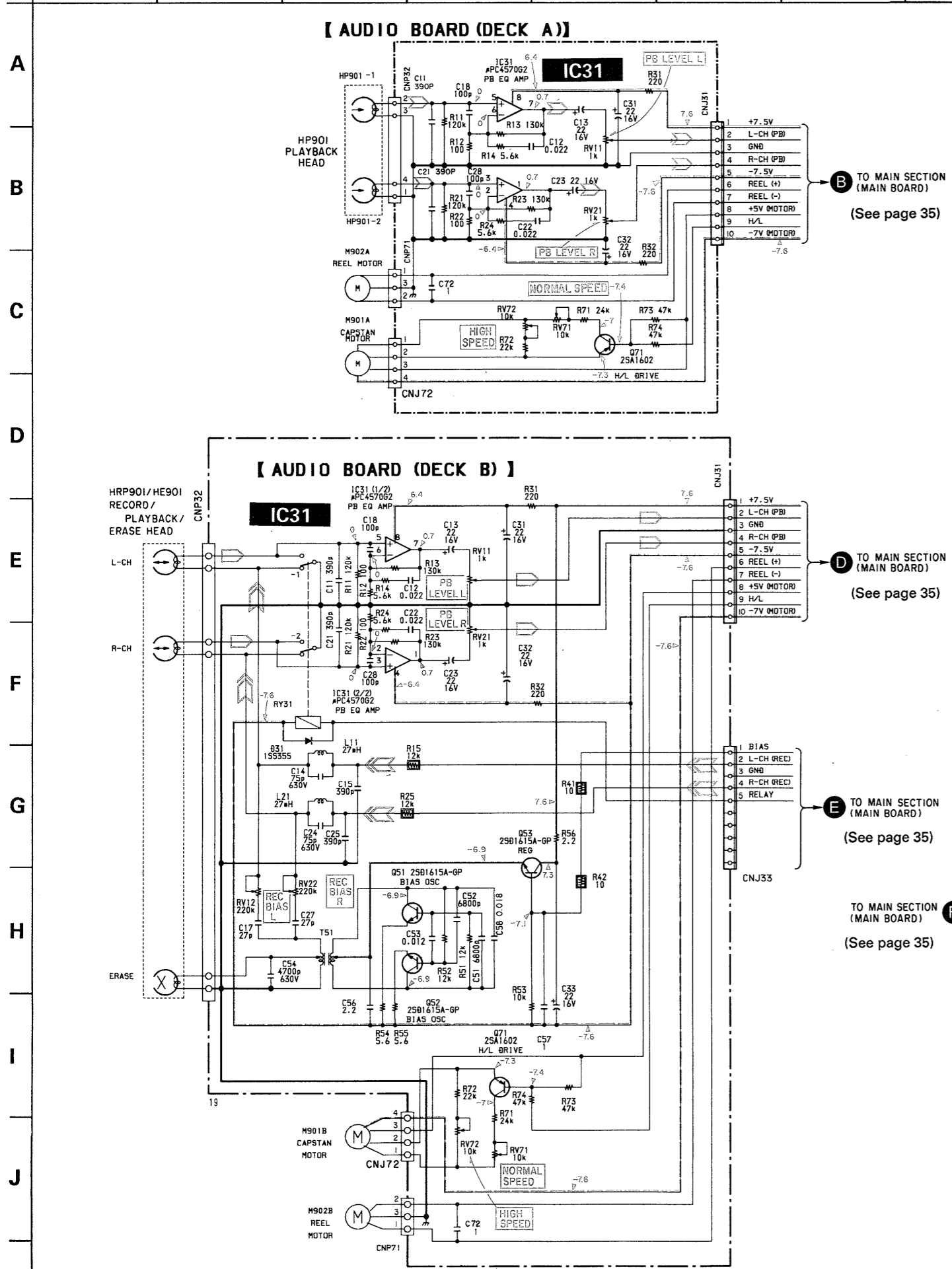

Notes on schematic diagram:

- All capacitors are in μF unless otherwise noted. pF: μF 50WV or less are not indicated except for electrolytics and tantalums.
- All resistors are in ohms, 1/4W or less unless otherwise noted.
- : Fuse resistor

The components identified by mark Δ or dotted line with mark Δ are critical for safety. Replace only with part number specified.

Les composants identifiés par une marque Δ sont critiques pour la sécurité. Ne les remplacer que par une pièce portant le numéro spécifié.

- : B+ Line
- : B- Line
- : Adjustment for repair
- Voltage are dc with respect to ground under no-signal conditions.
- No mark: PLAY
- () : REC
- Voltages are taken with a VOM (input impedance 10M Ω). Voltage variations may be noted due to normal production tolerances.
- Signal path
- : PLAY (DECK A)
- : PLAY (DECK B)
- : REC (DECK B)

● SEMICONDUCTOR LOCATION - AEP, UK, Germany, East European Model -

(MAIN SECTION)

Ref. No.	Location
D301	C-1
D302	C-3
D304	C-10
D305	B-10
D601	H-10
D602	H-4
D603	E-5
D605	E-4
D606	F-2
D607	F-3
D608	F-2
D610	G-8
D611	G-8
D612	G-9
IC101	G-8
IC102	H-11
IC103	H-7
IC104	F-10
IC105	F-9
IC351	B-6
IC601	G-6
IC602	G-2
IC603	G-1
IC604	H-3
IC605	H-4
Q101	F-9
Q102	G-9
Q201	F-8
Q202	F-9
Q601	I-10
Q602	I-9
Q603	H-9
Q604	E-9
Q605	F-9
Q607	H-6
Q608	G-7
Q609	F-4
Q611	G-3
Q612	H-2
Q613	H-2
Q616	G-4
Q617	G-3
Q619	G-4
Q620	G-5

Notes on printed wiring boards:

- — : Indicated a lead wire mounted on the component side
- : Parts mounted on the conductor side
- : Through hole
- ▨ : Pattern from the side which enables seeing
- ▩ : Pattern of the rear side

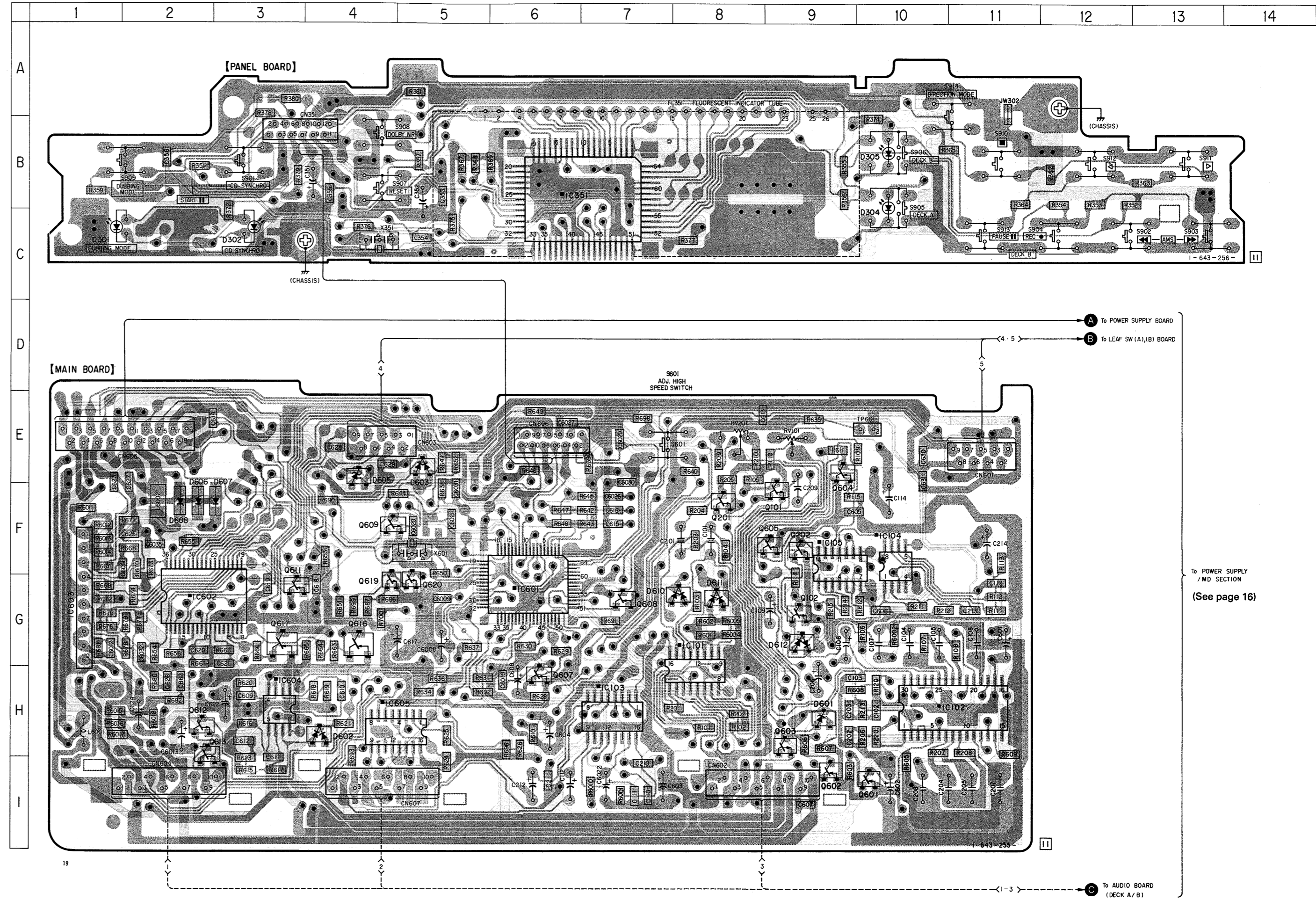

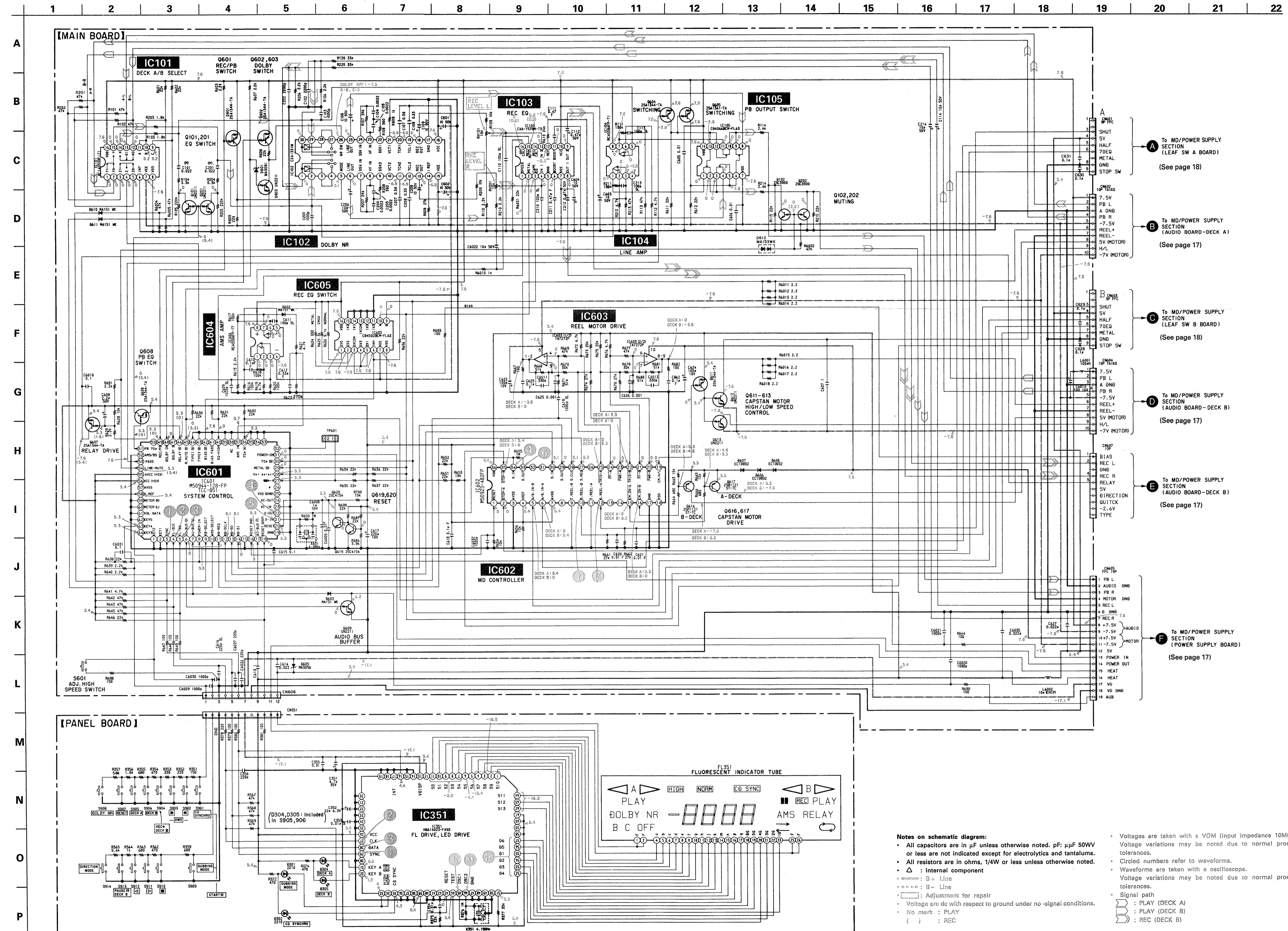

● IC BLOCK DIAGRAMS - AEP, UK, Germany, East European Model -

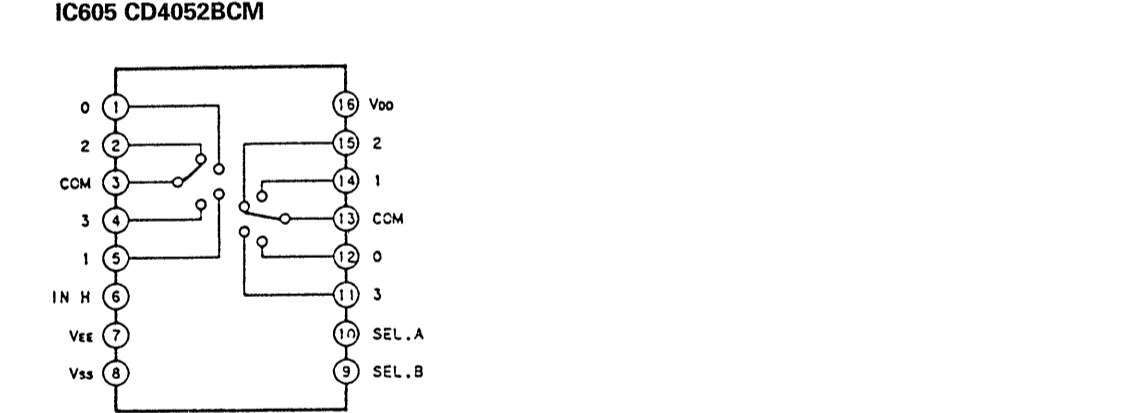
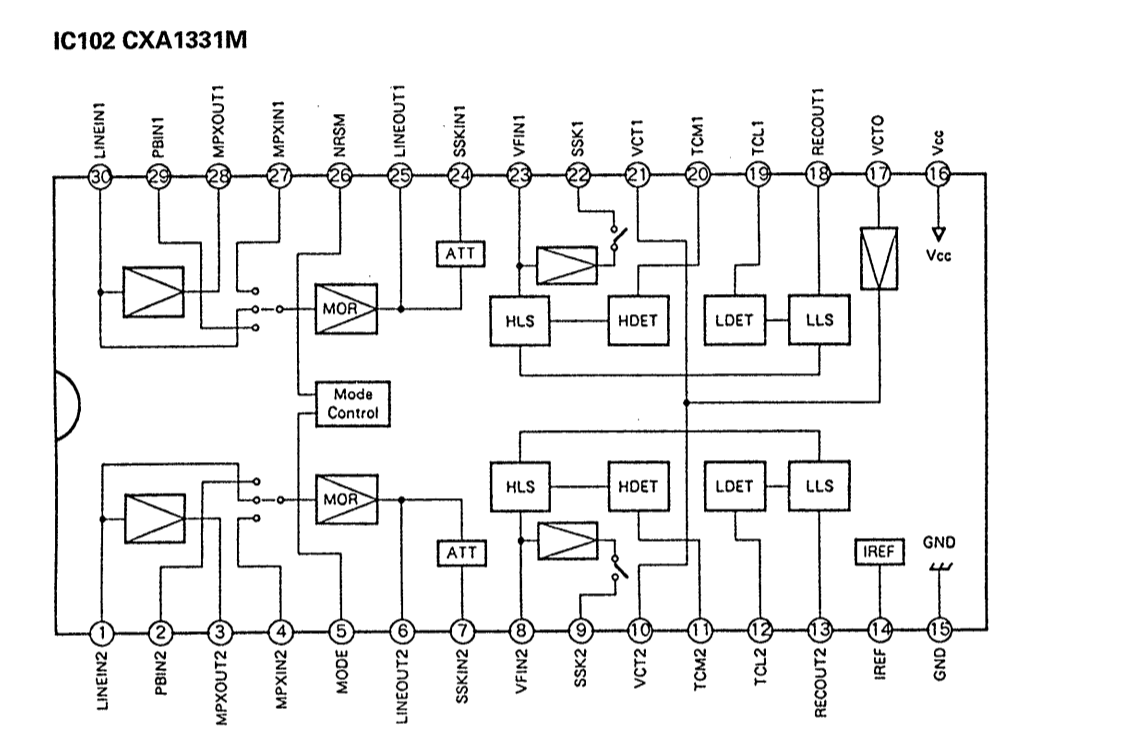
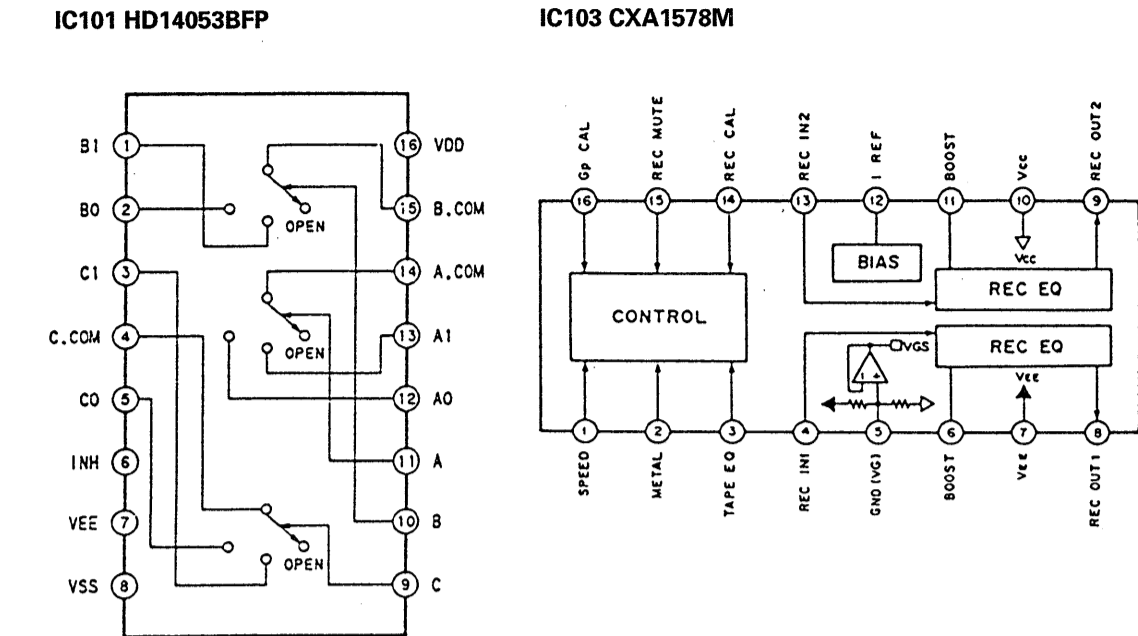

● FLUORESCENT INDICATOR TUBE (FL351)

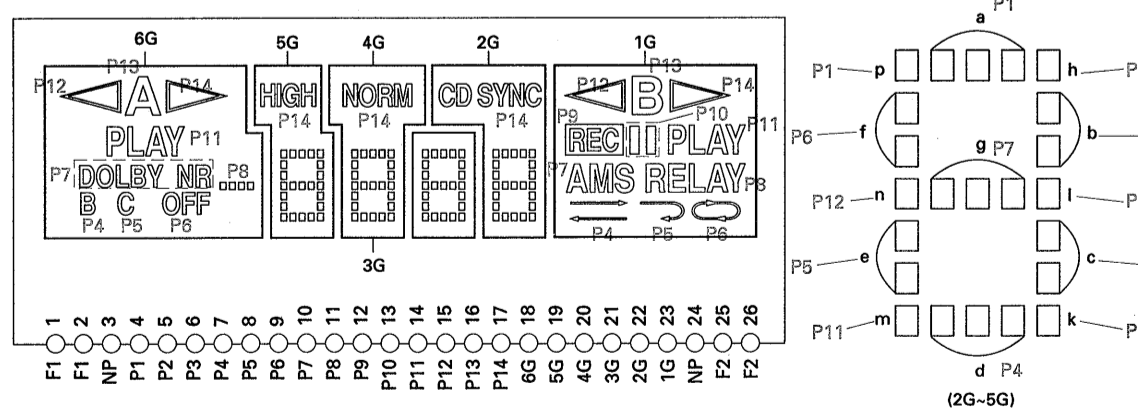

Notes on schematic diagram:

- All capacitors are in μF unless otherwise noted. pF: μpF 50WV or less are not indicated except for electrolytics and tantalums.
- All resistors are in ohms, 1/4W or less unless otherwise noted.
- Δ : Internal component
- : Line
- - -: Line
- : Adjustment for repair
- Voltage are dc with respect to ground under no-signal conditions.
- No mark: PLAY
- { } : REC

Voltagcs are taken with a VOM (input impedance 10M Ω). Voltage variations may be noted due to normal production tolerances.

- Circled numbers refer to waveforms.
- Waveforms are taken with a oscilloscope.
- Voltage variations may be noted due to normal production tolerances.
- Signal path
- : PLAY (DECK A)
- : PLAY (DECK B)
- : REC (DECK B)

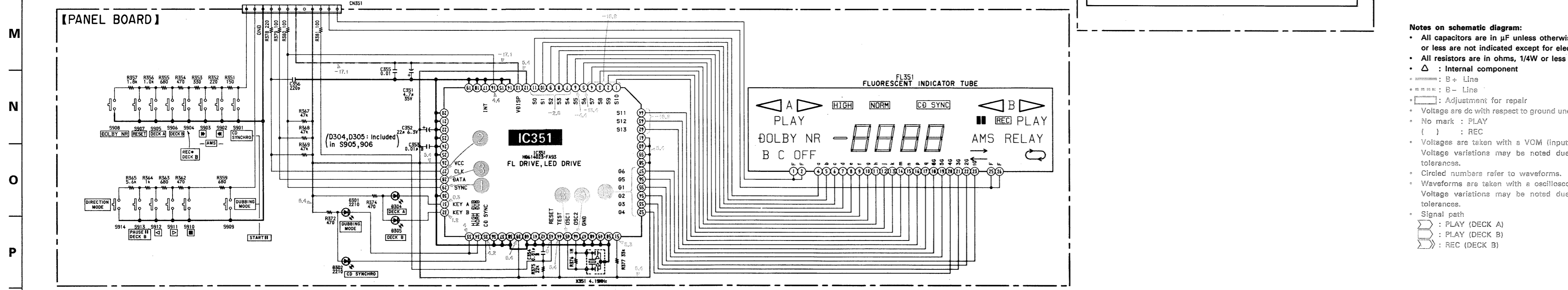
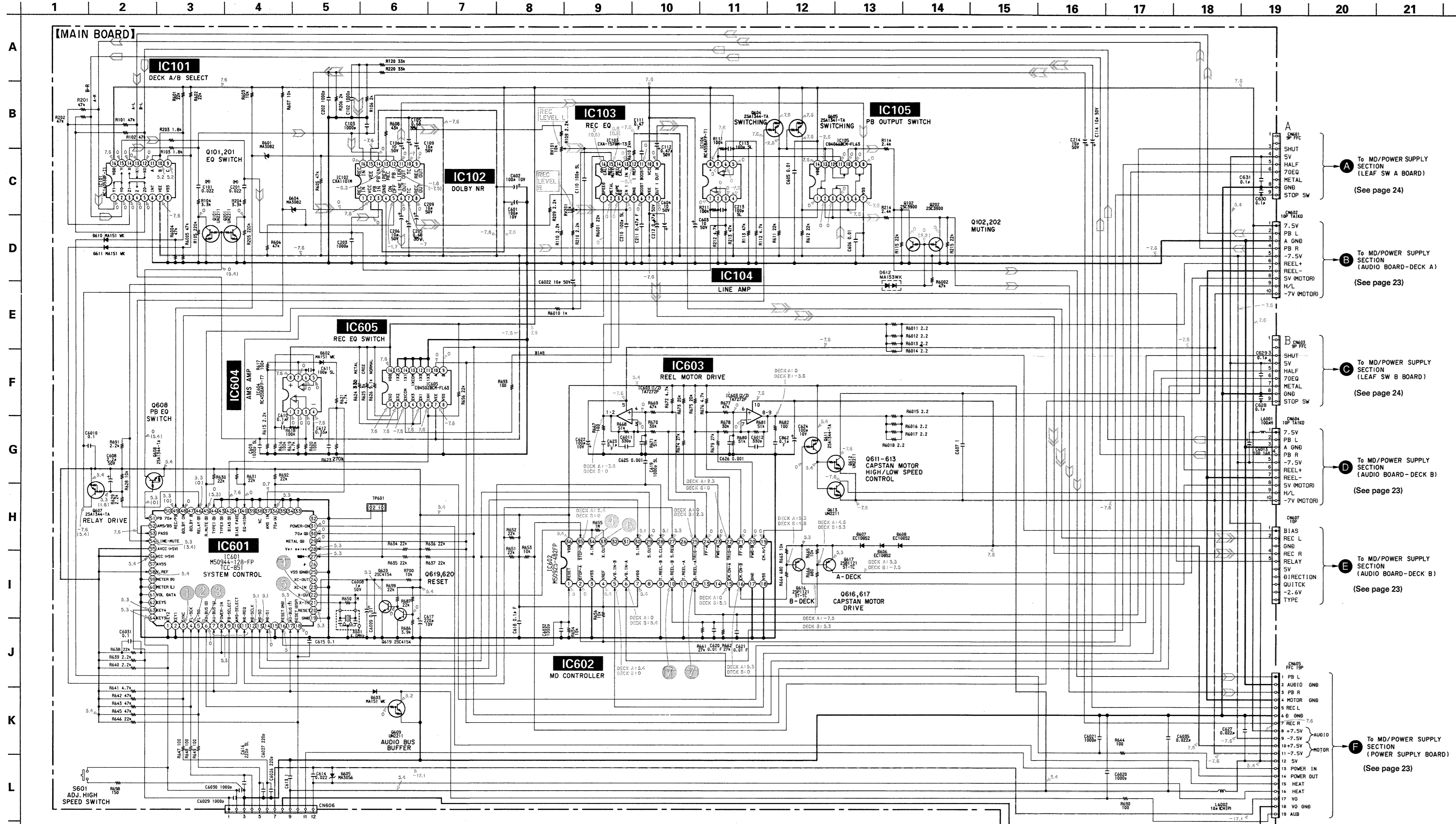

IC BLOCK DIAGRAMS - Canadian, AEP, UK, Germany Model -

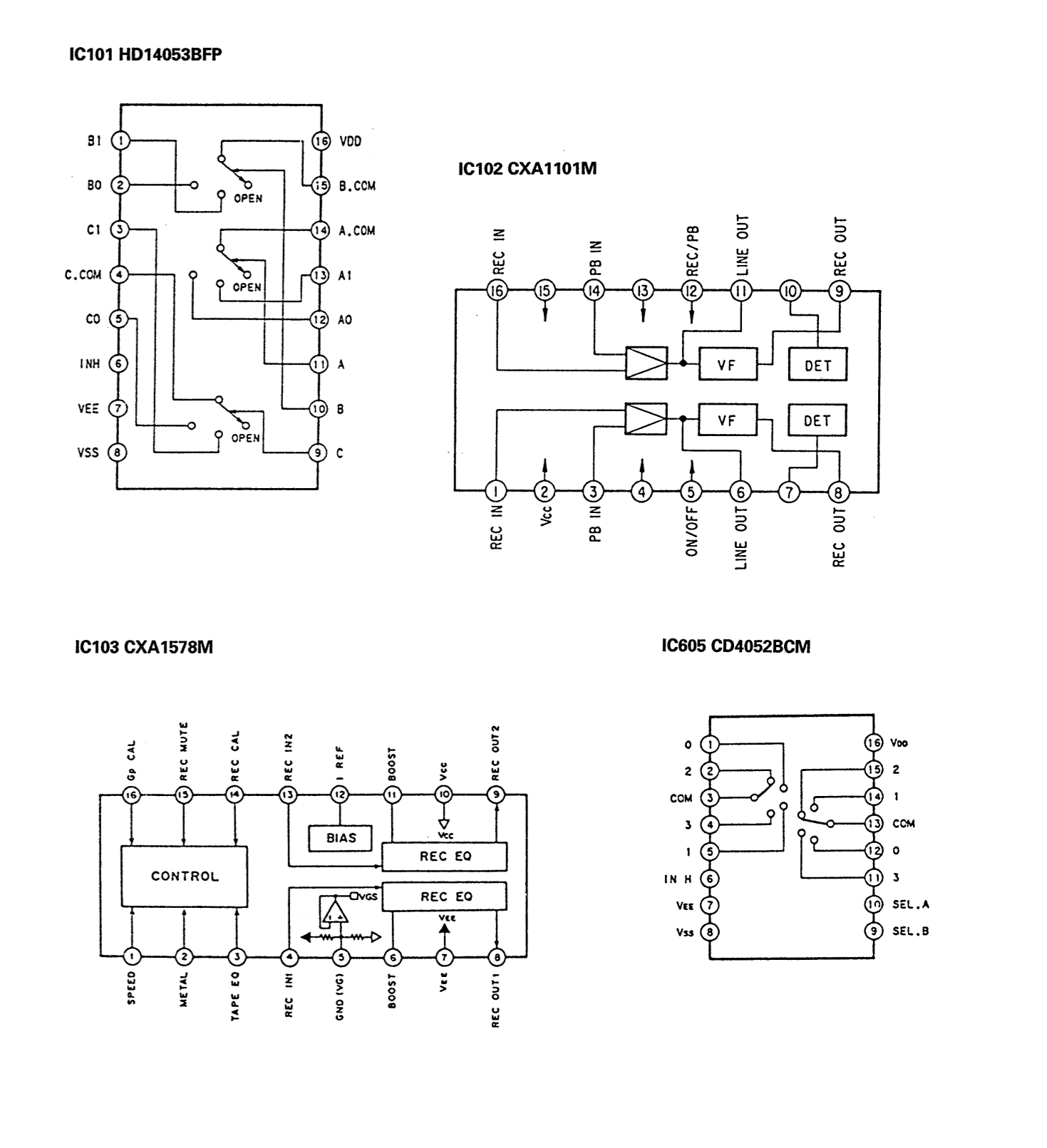

FLUORESCENT INDICATOR TUBE (FL351)

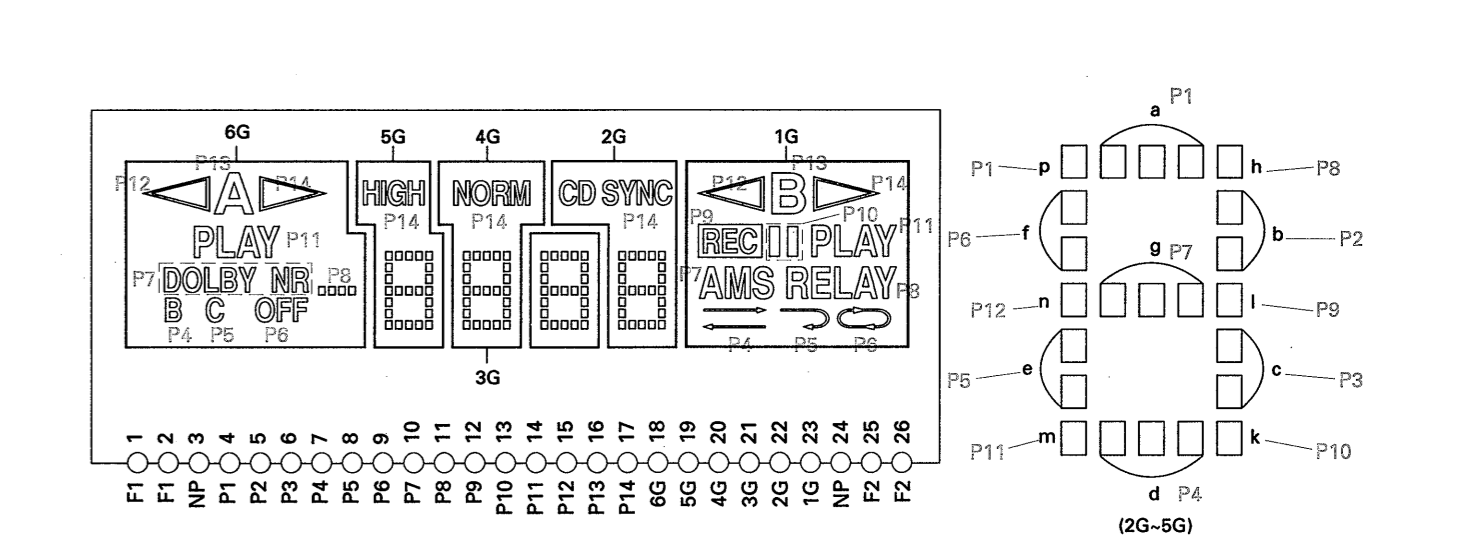

- Notes on schematic diagram:**
- All capacitors are in μF unless otherwise noted. pF: μpF 50WV or less are not indicated except for electrolytics and tantalums.
 - All resistors are in ohms, 1/4W or less unless otherwise noted.
 - Δ : Internal component
 - ---: B+ Line
 - ----: B- Line
 - []: Adjustment for repair
 - Voltage are dc with respect to ground under no-signal conditions.
 - No mark: PLAY
 - (): REC
 - Voltages are taken with a VOM (input impedance 10M Ω). Voltage variations may be noted due to normal production tolerances.
 - Circled numbers refer to waveforms.
 - Waveforms are taken with an oscilloscope. Voltage variations may be noted due to normal production tolerances.
 - Signal path
 - ▶ : PLAY (DECK A)
 - ◀ : PLAY (DECK B)
 - ◁ : REC (DECK B)

● SEMICONDUCTOR LOCATION

- Canadian, Australian, E, Saudi Arabia Model -

(MAIN SECTION)

Ref. No.	Location
D301	C-1
D302	C-3
D304	C-10
D305	B-10
D601	H-10
D602	H-4
D603	E-5
D604	I-10
D605	E-4
D606	F-2
D607	F-3
D608	F-2
D610	G-8
D611	G-8
D612	G-9
IC101	G-8
IC102	H-10
IC103	H-7
IC104	F-10
IC105	F-9
IC351	B-6
IC601	G-6
IC602	G-2
IC603	G-1
IC604	H-3
IC605	H-4
Q101	F-9
Q102	G-9
Q201	F-8
Q202	F-9
Q604	E-9
Q605	F-9
Q607	H-6
Q608	G-7
Q609	F-4
Q611	G-3
Q612	H-2
Q613	H-2
Q616	G-4
Q617	G-3
Q619	G-4
Q620	G-5

Notes on printed wiring boards:

- : Indicated a lead wire mounted on the component side
- : Parts mounted on the conductor side
- : Through hole
- ▨ : Pattern from the side which enables seeing
- ▩ : Pattern of the rear side

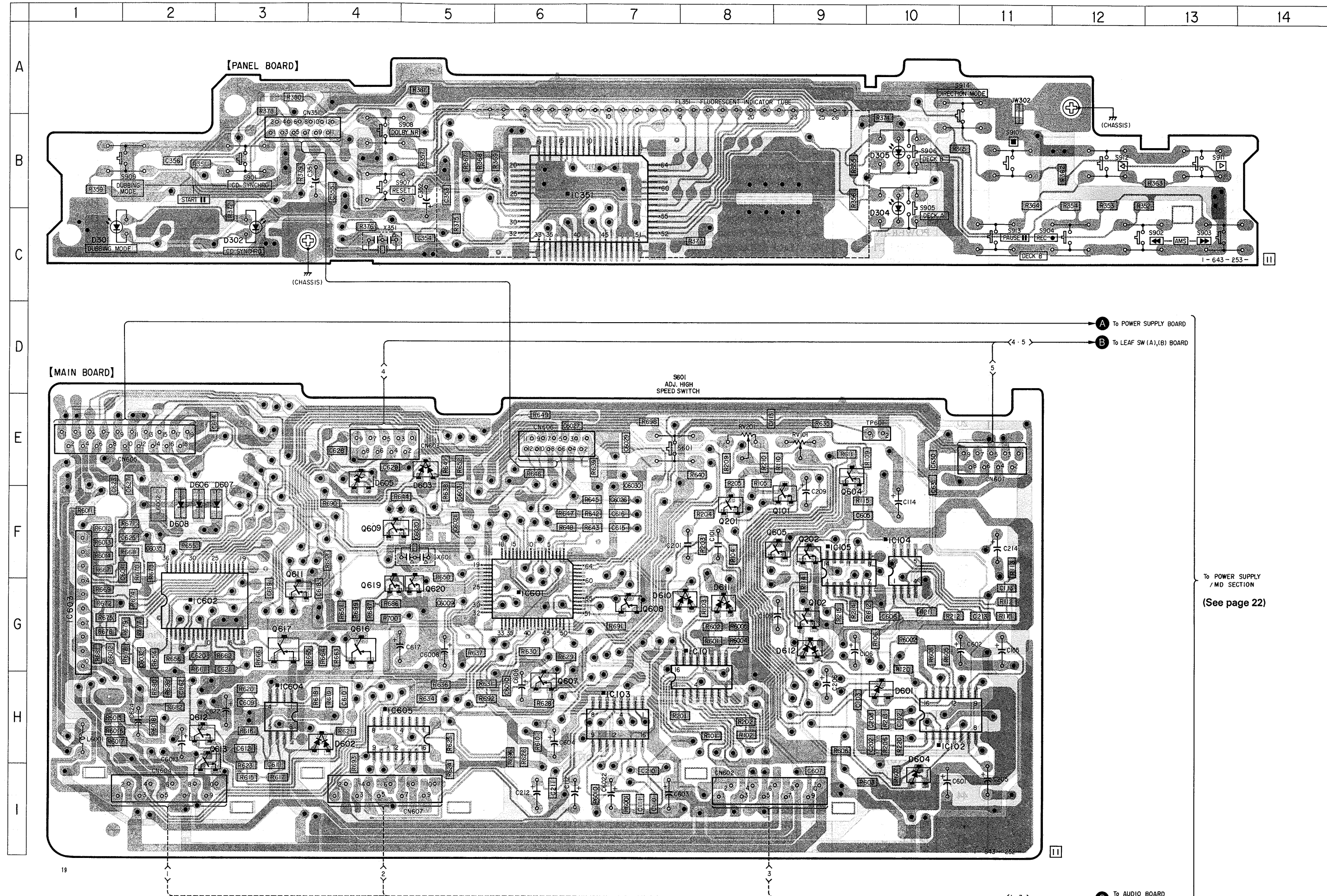

To POWER SUPPLY / MD SECTION
(See page 22)

5-12. PIN FUNCTIONS

IC351 display microprocessor HD614023-FA93

Fluorescent lamp indicator is activated by receiving data from IC601 (system controller).

Pin No.	Pin Name	I/O	Description
1-11 12 13 14, 15 16	S10-S0 VDISP SYNC	O — I	FL indicator tube (FL351) segment output Not used. (+5.6 V) Power supply for activating the FL indicator tube (−20 V) Not used. (GND) Interrupt input. Data transmission from IC601 (system controller) is checked.
17 18-25 26 27 28	INT Vcc CLK DATA	I I — I I	Not used. (GND) Not used. (GND) Power supply terminal (+5.6 V) Data transmission clock input from IC601 (system controller) Serial data input from IC601 (system controller)
29 30 31 32 33	SYNC KEY A KEY B HIGH DUB	I O O O	Sync signal input which indicates the first byte of data sent from IC601 (system controller) Not used. (GND) LED (D304) light output in the DECK A. LED (D305) light output in the DECK B. LED (D301) light output in the high speed dubbing mode.
34 35 36-38 39 40-42	NORM DUB CD SYNC FLCHECK	O O I	LED (D301) light output in the normal speed dubbing mode. LED (D302) light output in the CD sync mode. Not used. (GND) All the FL indicator tubes are lit when this port is set to "L". (Normally +5.6 V) Not used. (GND)
43 44 45 46 47	RESET TEST OSC1 OSC2 GND	I I I O —	Reset input from IC601 (system controller). "L": Reset. Not used. (+5.6 V) Clock input (4.19 MHz) Clock output Power supply terminal (GND)
48-50 51 52-57 58-61 62-64	G0-G6 S13-S11	O O	Not used. (GND) Not used. (Pull-up) FL indicator tube (FL351) grid output Not used. (+5.6 V) FL indicator tube (FL351) segment output

IC601 system controller M50944-128FP

The system is wholly controlled by communication between IC351 (display microprocessor) and IC602 (mechanism controller).

Pin No.	Pin Name	I/O	Description
1	KEY2	I	Not used. (GND)
2	KEY1	I	Not used. (GND)
3	SYNC	O	Sync signal output which indicates the first byte of data sent to IC351 (display microprocessor).
4	FL-SCK	O	Data transmission clock output to IC351 (display microprocessor).
5	FL-SO	O	Serial data output to IC351 (display microprocessor).
6	AU-BUS	O	Audio bus output.
7	AU-BUS	I	Audio bus input (negative edge).
8	POWER-IN	I	Power-off detection input. "L": Power OFF.
9	PB-SELECT	O	Deck A/B switch output in the playback mode. "L": deck B, "H": deck A.
10	AMS-SELECT	O	AMS amplifier input switch output
11	MD-REQ	I	Data request input from IC602 (mechanism controller)
12	MD-SCLK	O	Data transmission clock output to IC602 (mechanism controller)
13	MD-SO	O	Serial data output to IC602 (mechanism controller)
14	MD-SI	I	Serial data input from IC602 (mechanism controller)
15		O	Not used. (GND)
16	RESET (MD)	O	IC602 (mechanism controller) reset signal output.
17	AU-BUS	I	Audio bus input (positive-edge)
18	RESET (DSP)	O	IC351 (display microprocessor) reset signal output.
19	GND	—	Power supply terminal. (GND)
20	RESET	I	System reset input. "L": Reset.
21	X-IN	I	Clock input (4 MHz)
22	X-OUT	O	Clock output
23	XC-IN	I	Not used. (GND)
24	XC-OUT	O	Not used. (open)
25	VSS	—	Power supply terminal (GND)
26	N. C.		Not used. (open)
27	TEST	I	Electrical adjustment test mode setting input. This set enters into the test mode when the power is on and it is set to "L". *1
28	VAR SELECT	I	Not used. (pull-up)
29	METAL (B)	I	Metal switch (S83) input for deck B. "H": Metal.
30	70 μ (B)	I	Chrome switch (S82) input for deck B. "L": Normal.
31	POWER-ON	O	Power on output terminal. "L": Power ON.
32-35			Note used. (GND)
36	70 μ (A)	I	Chrome switch (S82) input for deck A. "L": Normal.
37	AMS IN	I	Signal input from the AMS amplifier. "H": Detected, "L": Not detected.
38	N. C.		Not used. (GND)
39			Not used. (GND)
40	EQ-HIGH	O	REC equalizer characteristic switch output "H": High speed, "L": Normal speed.
41	BIAS FADE	O	Not used. (GND)
42	BIAS (B)	O	Bias ON/OFF switch output. "H": OFF, "L": ON.
43	TYPE II (B)	O	Not used. (GND)
44	TYPE I (B)	O	Not used. (GND)
45	R. MUTE (B)	O	REC mute control output. "L": Mute ON, "H": Mute OFF.
46	RELAY (B)	O	Mechanism deck head switch control output. "L": ON.
47	DOLBY B	O	Dolby B/C switch control output. "L": Dolby C, "H": Dolby B.
48	DOLBY ON	O	Dolby ON/OFF switch control output. "L": ON, "H": OFF.

Pin No.	Pin Name	I/O	Description	
49	REC/PB	O	Dolby amplifier REC/PB switch output. "L": REC, "H": PB.	
50		O	Not used. (open)	
51		PB 70 μ	O	Playback equalizer characteristic switch output. "H": Normal, "L": Chrome or metal.
52		AMS/BS	O	Not used.
53		PASS	O	PASS amplifier switch output for LINE OUT. "L": PASS amplifier, "H": Through.
54	LINE-MUTE	O	Line mute control output. "L": MUTE OFF, "H": MUTE ON.	
55	AVCC	—	Power supply terminal. (+5 V)	
56	VCC	—	Power supply terminal. (+5 V)	
57	AVSS	—	Power supply terminal. (GND)	
58	V. REF	I	Reference voltage input for A/D input port (+5 V)	
59	METER (R)	I	Level meter signal input (R-CH). Not used on this set.	
60	METER (L)	I	Level meter signal input (L-CH). Not used on this set.	
61	VOL DATA	I	Not used. (GND)	
62	KEY5	I	Not used. (GND)	
63	KEY4	I	Key input. (analog) *2	
64	KEY3	I	Key input. (analog) *2	

*1 Test mode

When the power is on and pin ⑦ is set to "L" (TP601 is shortened.), the set enters the electrical adjustment test mode and the followings can be available.

(1) High speed playback

When the S601 (in the main board) is turned ON in playback mode, high-speed playback mode is actuated.

(2) Source monitor

Recording signals can be monitored through the OUTPUT terminal (see page 4) because the line short is removed in recording.

(3) Recording memory

Recording memory is set to ON when the tape counter is reset at the record start point.

(4) Mode display

The counter displays as shown below when the counter mode is set to the deck A and the deck A button of deck A/B switch is pressed, or when the counter mode is the B deck and the B deck button is pressed.

(5) When this terminal is set back to "H" after it is set to the test mode in "L" of the power-on mode, all the FL indicator tubes are lit. (The mechanism block continues to operate as before it is set to "H".)

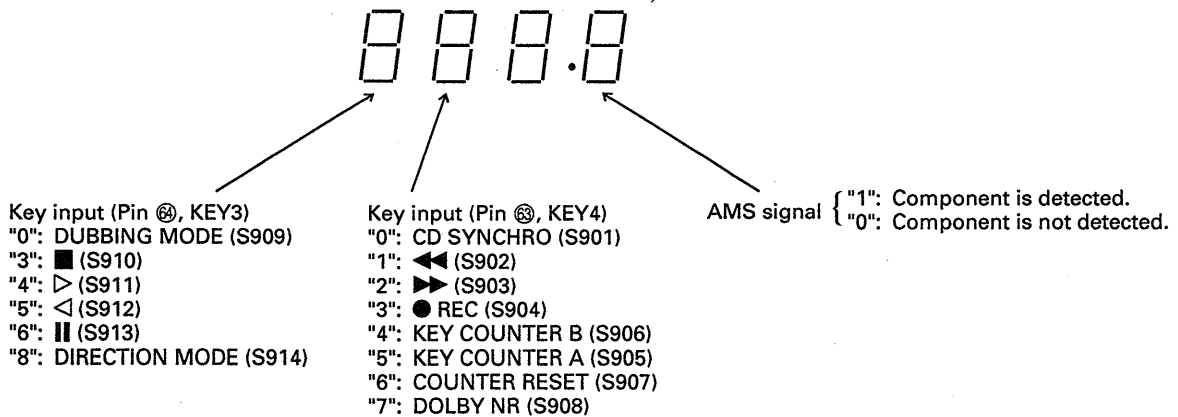

*2 Key input (analog port)

Voltage (V)	0	0.3	0.7	1.2	1.7	2.3	2.8	4.0
Pin ⑤, KEY4	CD SYNCHRO	◀	▶	● REC	KEY COUNTER B	KEY COUNTER A	COUNTER RESET	DOLBY NR
Pin ⑥, KEY3	DUBBING MODE			■	▷	◁	PAUSE	DIRECTION MODE

IC602 mechanism controller M50925-482FP

The mechanism deck is controlled by receiving data from IC601 (system controller).

Pin No.	Pin Name	I/O	Description
1	RESET	I	Reset input from IC601 (system controller). "L": Reset.
2	STOP-A	I	Deck A stop switch (S81) input. "H": Stop.
3	AVSS	—	Power supply terminal (GND)
4	Vref	I	A/D input port reference voltage input.
5	A/D. IN-B	I	Deck B leaf switch input (analog). *1
6	A/D. IN-A	I	Deck A leaf switch input (analog). *1
7	AVDD	—	Power supply terminal. (+5 V)
8	N. C.		
9	T. REEL-B	I	Not used. (GND)
10	S. REEL-B	I	Deck B supply reel table sensor (IC81)
11	T. REEL-A	I	Not used. (GND)
12	S. REEL-A	I	Deck A supply reel table sensor (IC81)
13, 14	N. C.		
15	CM. ON-A	O	Deck A capstan motor (M901A) ON/OFF control output. "L": OFF, "H": ON.
16	CM. ON-B	O	Deck B capstan motor (M901B) ON/OFF control output. "L": OFF, "H": ON.
17	GND	—	Power supply terminal. (GND)
18	VSS	—	Power supply terminal. (GND)
19	CM. H/L	O	Capstan motor (M901A, M901B) speed control switch output. "H": High speed, "L": Normal speed.
20	FWD-B	O	Deck B reel motor (M902B) control output. *2 The reel motor is activated by combining these three outputs.
21	FF-B	O	
22	TRIG-B	O	
23	FWD-A	O	Deck A reel motor (M902A) control output. *2 The reel motor is activated by combining these three outputs.
24	FF-A	O	
25	TRIG-A	O	
26	N. C.		
27	S. REQ	O	Data request output to IC601 (system controller).
28	S. CLK	I	Data transmission clock input from IC601 (system controller).
29	S. OUT	O	Serial data output to IC601 (system controller).
30	S. IN	I	Serial data input from IC601 (system controller).
31, 32	N. C.		
33	XOUT	O	Clock output.
34	XIN	I	Clock input. (4 MHz)
35	STOP-B	I	Deck B stop switch (S81) input. "H": Stop.
36	VDD	—	Power supply terminal. (+5 V)

*1 HALF, REC safety tab leaf switch input

Leaf switch	Voltage	1	1.9	2.8	3.9	5
		Half S86	ON			
REC safety tab, side A S84		OFF	ON	OFF	ON	OFF
REC safety tab, side B S85		ON	ON	OFF	OFF	OFF

↑ ↑ ↑ ↑ ↑
 REC available REC available REC inhibit for REC available Tape is not set.
 for only side B. for both sides A. both sides A for only side A.
 and B.
 ───
 Tape is set.

*2 Reel motor drive

Output port	Mode	FF	TRIG (kick)	STOP	FWD
Pin ② and ④	FF	L	H	L	L
Pin ② and ④	TRIG	H	L	L	H
Pin ② and ④	FWD	H	H	L	L

Reel motor drive amplifier output voltage

Output	Voltage
TRIG	+6 V
FF.REW	-5 V
FWD	-3 V

5-13. WAVEFORMS

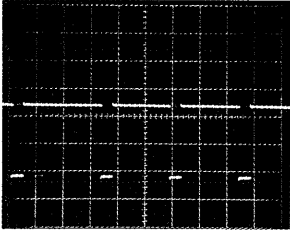

1 IC601 ③pin (SYNC),
IC351 ⑳pin (SYNC)
5.2Vp-p, 2.5msec

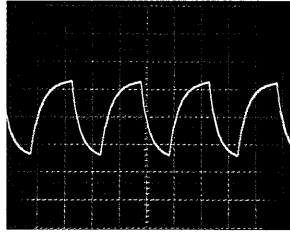

6 IC602 ⑳pin (X OUT)
5.2Vp-p, 0.25μsec

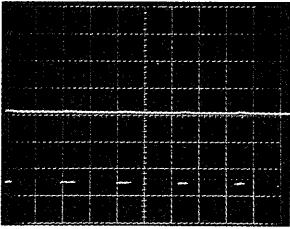

2 IC601 ④pin (FL-SCK),
IC351 ㉑pin (CLK)
5.2Vp-p, 2.2msec

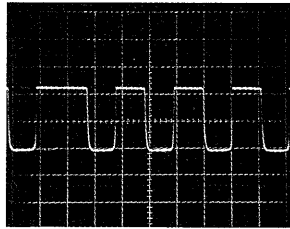

7 IC602 ⑩, ⑫ pin
(S-REEL-A/B)
FF/REW MODE
4.8Vp-p, 19msec

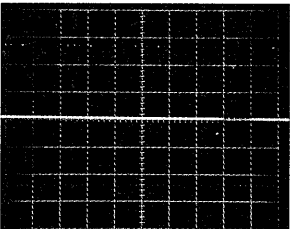

3 IC601 ⑤pin (FL-SO),
IC351 ㉒pin (DATA)
5.4Vp-p, 26msec

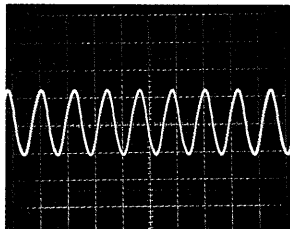

8 IC351 ④⑤pin (OSC1)
4.8Vp-p, 0.24μsec

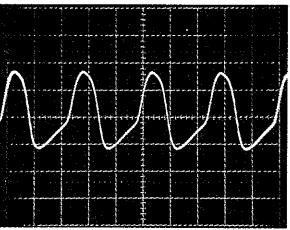

4 IC601 ㉓pin (X OUT),
IC602 ⑳pin (X IN)
5.6Vp-p, 0.25μsec

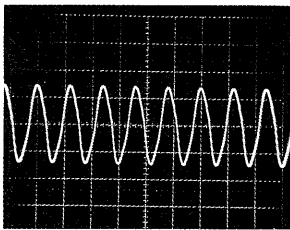

9 IC351 ④⑥pin (OSC2)
5.8Vp-p, 0.24μsec

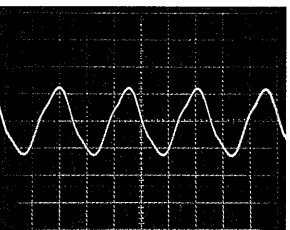

5 IC601 ㉔pin (X IN)
5.2Vp-p, 0.25μsec

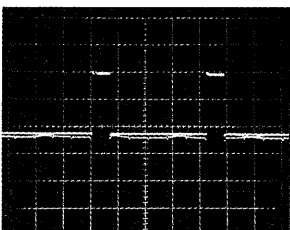

10 IC351 ⑤②-⑤⑦pin
(G4-1, 5, 6)
24Vp-p, 8.4msec

SECTION 6 EXPLODED VIEWS

NOTE:

- -XX, -X mean standardized parts, so they may have some differences from the original one.
- Color Indication of Appearance Parts
Example:
KNOB,BALANCE(WHITE)...(RED)
 ↑ ↑
 Parts color Cabinet's color
- Items marked "*" are not stocked since they are seldom required for routine service. Some delay should be anticipated when ordering these items.
- The mechanical parts with no reference number in the exploded views are not supplied.
- Hardware(# mark) list is given in the last of this parts list.
- G : Germany Model
- AUS : Australian Model
- EA : Saudi Arabia Model
- EE : East European Model

The components identified by mark Δ or dotted line with mark Δ are critical for safety.
Replace only with part number specified.

Les composants identifiés par une marque Δ sont critiques pour la sécurité.
Ne les remplacer que par une pièce portant le numéro spécifié.

6-1. CHASSIS SECTION

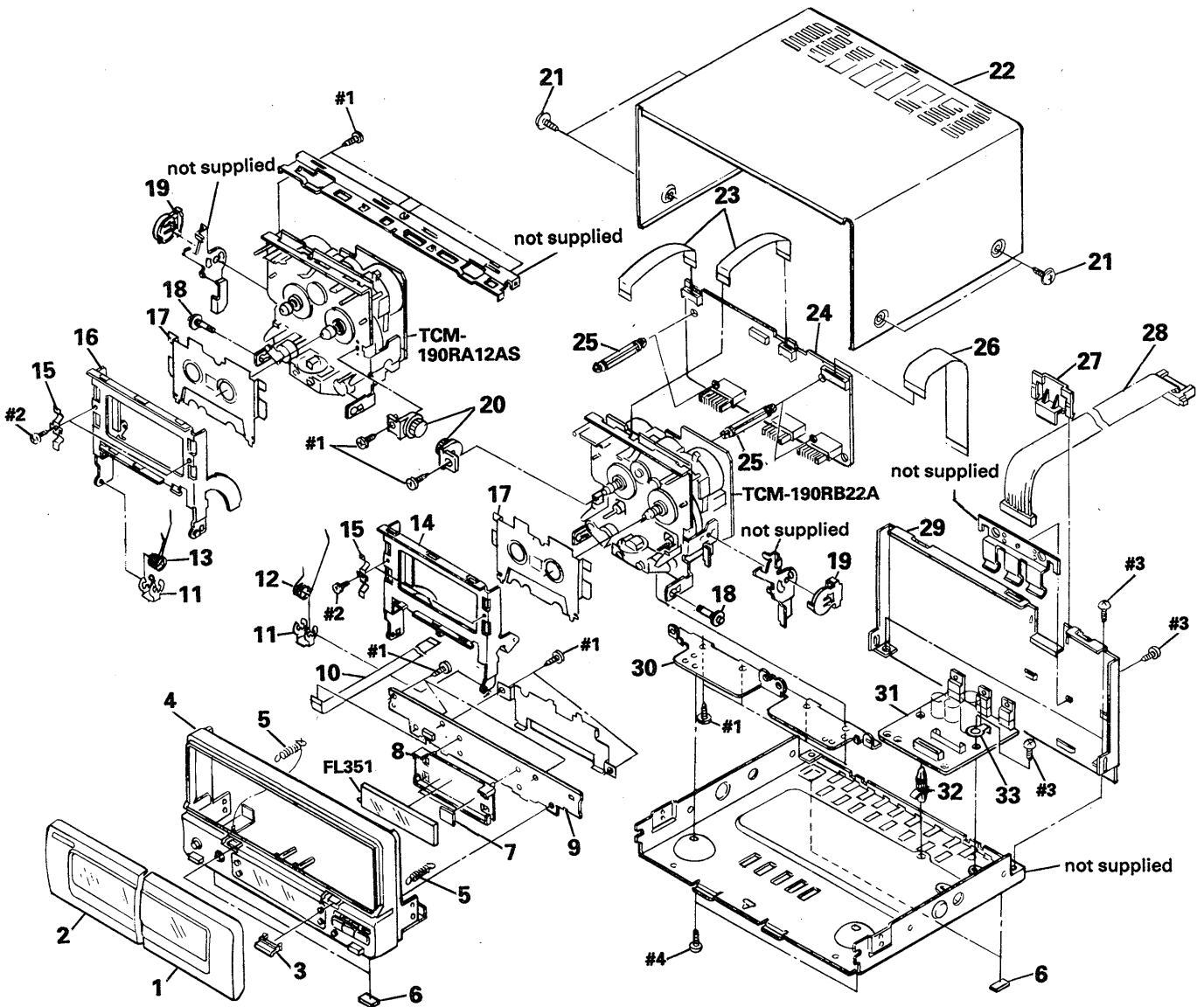

Ref. No.	Part No.	Description	Remarks	Ref. No.	Part No.	Description	Remarks
1	X-3364-805-1	LID(B) ASSY, CASSETTE(Canadian, AUS, E, EA)		19	3-354-957-01	JOINT (LOCK LEVER)	
1	X-3364-807-1	LID(B) ASSY, CASSETTE(AEP, UK, G, EE)		20	3-354-963-01	DAMPER	
2	X-3364-804-1	LID(A) ASSY, CASSETTE		21	3-704-366-01	SCREW (CASE) (M3X8)	
3	3-377-868-01	COVER (AZIMUTH)		* 22	4-951-094-11	CASE	
4	X-3364-803-1	PANEL ASSY, FRONT		23	1-590-902-11	WIRE, FLAT TYPE (9 CORE)	
5	3-489-099-11	SPRING, TENSION		* 24	A-2006-711-A	MAIN BOARD, COMPLETE(Canadian, AUS, E, EA)	
6	4-930-336-11	FOOT (FELT)		* 24	A-2006-714-A	MAIN BOARD, COMPLETE(AEP, G, EE)	
* 7	4-932-810-11	CUSHION (FL)		* 24	A-2006-791-A	MAIN BOARD, COMPLETE(UK)	
* 8	3-367-839-01	HOLDER, FL TUBE		* 25	3-682-419-21	HOLDER, P. C. B	
* 9	A-2006-712-A	PANEL BOARD, COMPLETE(Canadian, AUS, E, EA)		26	1-690-893-11	WIRE (FLAT TYPE) (19 CORE)	
* 9	A-2006-715-A	PANEL BOARD, COMPLETE (AEP, G, EE)		* 27	3-377-869-01	CLAMP (CONNECTOR)	
* 9	A-2006-792-A	PANEL BOARD, COMPLETE (UK)		28	1-690-878-11	CORD (WITH CONNECTOR)	
10	1-690-892-11	WIRE (FLAT TYPE) (12 CORE)		* 29	3-376-858-11	PANEL, BACK	
11	3-367-720-01	RING (W), RETAINING		* 30	3-367-724-01	JOINT (LOWER)	
12	3-354-960-01	SPRING (LOADING R), TORSION		* 31	A-2006-713-A	POWER BOARD, COMPLETE(Canadian, AUS, E, EA)	
13	3-354-959-01	SPRING (LOADING L), TORSION		* 31	A-2006-716-A	POWER BOARD, COMPLETE(AEP, G, EE)	
14	X-3362-856-1	HOLDER (R) ASSY, CASSETTE		* 31	A-2006-793-A	POWER BOARD, COMPLETE(UK)	
15	3-340-137-01	SPRING, CASSETTE RETAINER		* 32	3-346-265-11	HOLDER, PC BOARD	
16	X-3362-857-1	HOLDER (L) ASSY, CASSETTE		* 33	4-942-204-01	PLATE, GROUND	
17	3-367-711-01	RETAINER, CASSETTE		FL351	1-519-708-11	INDICATOR, TUBE FLUORESCENT	
18	3-367-721-01	SHAFT (FULCRUM SHAFT)					

6-2. MECHANISM SECTION 1

DECK A : TCM-190RA12AS
DECK B : TCM-190RB22A

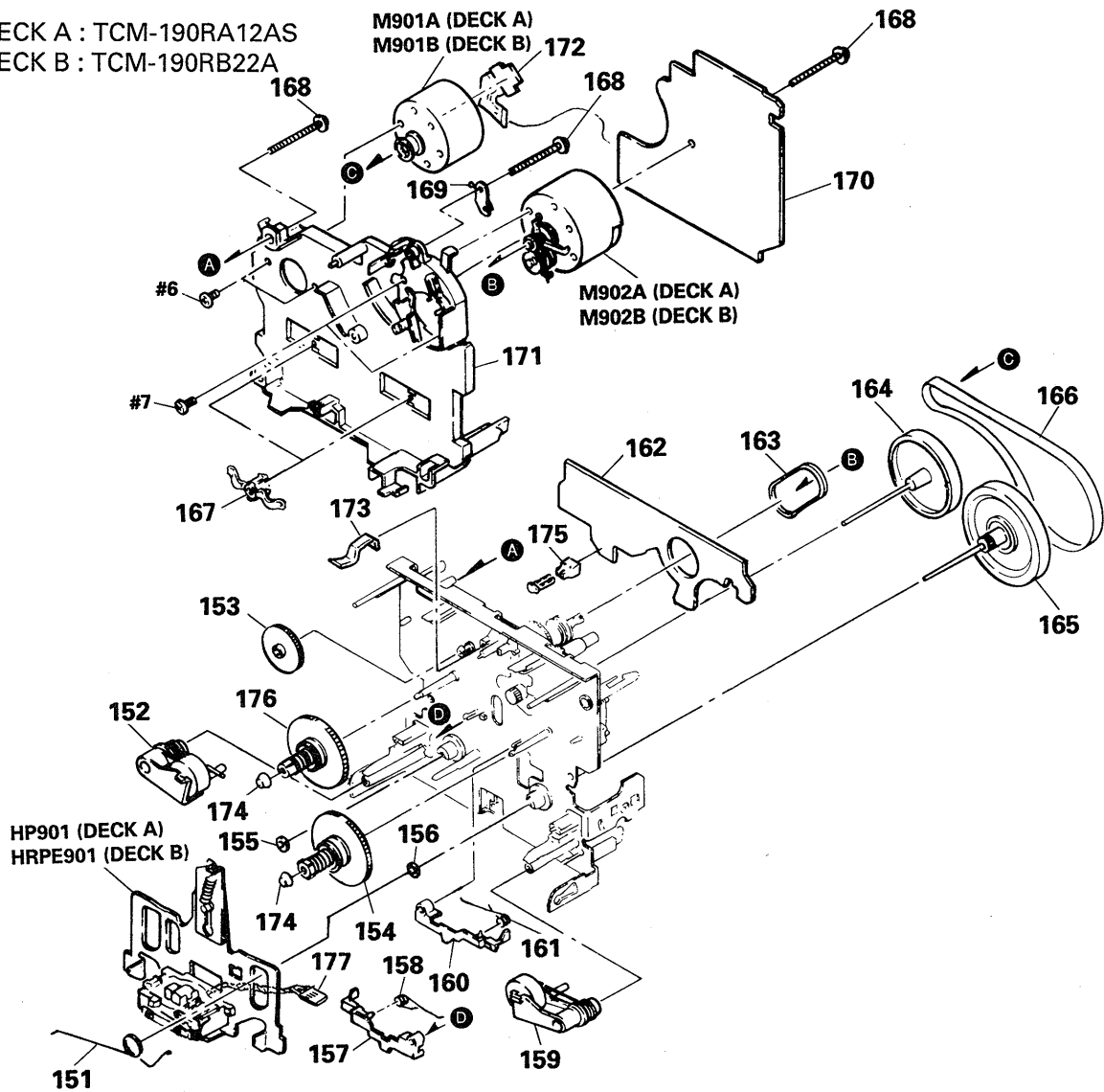

Ref. No.	Part No.	Description	Remarks	Ref. No.	Part No.	Description	Remarks
151	3-359-455-01	SPRING, TORSION		168	3-359-414-01	SCREW (+PTPWH 2X23)	
152	X-3359-409-1	LEVER (PINCH LEVER REV) ASSY		169	3-359-450-01	PLATE, GROUND	
153	3-359-424-01	GEAR (REV GEAR)		* 170	A-2006-399-A	AUDIO BOARD(RA12A), COMPLETE (DECK A)	
154	X-3359-404-1	TABLE ASSY, REEL		* 170	A-2006-400-A	AUDIO BOARD(RB22A), COMPLETE (DECK B)	
155	3-356-714-01	WASHER		* 171	3-359-436-01	BASE (THRUST RETAINER), FITTING	
156	3-356-713-01	WASHER		172	1-638-983-11	PC BOARD, MOTOR FLEXIBLE	
157	3-354-956-01	LEVER (EJ SAFTY LEVER R)		173	3-359-430-01	SPRING(CASSETTE RETAINER), LEAF	
158	3-354-962-01	SPRING (EJ SAFTY SPRING R)		174	3-362-308-01	CAP (REEL)	
159	X-3359-408-1	LEVER (PINCH LEVER FWD) ASSY		175	3-343-419-01	HOLDER (S SENSOR A)	
160	3-354-955-01	LEVER (EJ SAFTY LEVER L)		176	X-3362-078-1	TABLE ASSY (B), REEL	
161	3-354-961-01	SPRING (EJ SAFTY SPRING L)		* 177	1-690-419-11	WIRE, LEAD(WITH CONNECTOR)4CORE	
* 162	1-634-841-14	LEAF SW (A) BOARD (DECK A)		HP901	A-2003-958-B	BASE ASSY, HEAD (DECK A)	
* 162	1-634-841-14	LEAF SW (B) BOARD (DECK B)		HRPE901A	2003-838-A	BASE ASSY, HEAD (DECK B)	
163	3-359-466-01	BELT (FR), SQUARE		M901A	X-3359-417-1	CAPSTAN MOTOR ASSY (DECK A)	
164	X-3359-410-1	FLYWHEEL (REV) ASSY		M901B	X-3359-417-1	CAPSTAN MOTOR ASSY (DECK B)	
165	X-3364-554-1	FLYWHEEL (FWD) ASSY		M902A	X-3363-501-1	REEL MOTOR ASSY (DECK A)	
166	3-359-417-01	BELT (FLAT), CAPSTAN		M902B	X-3363-501-1	REEL MOTOR ASSY (DECK B)	
167	3-575-321-00	RETAINER, THRUST, CAPSTAN					

6-3. MECHANISM SECTION 2

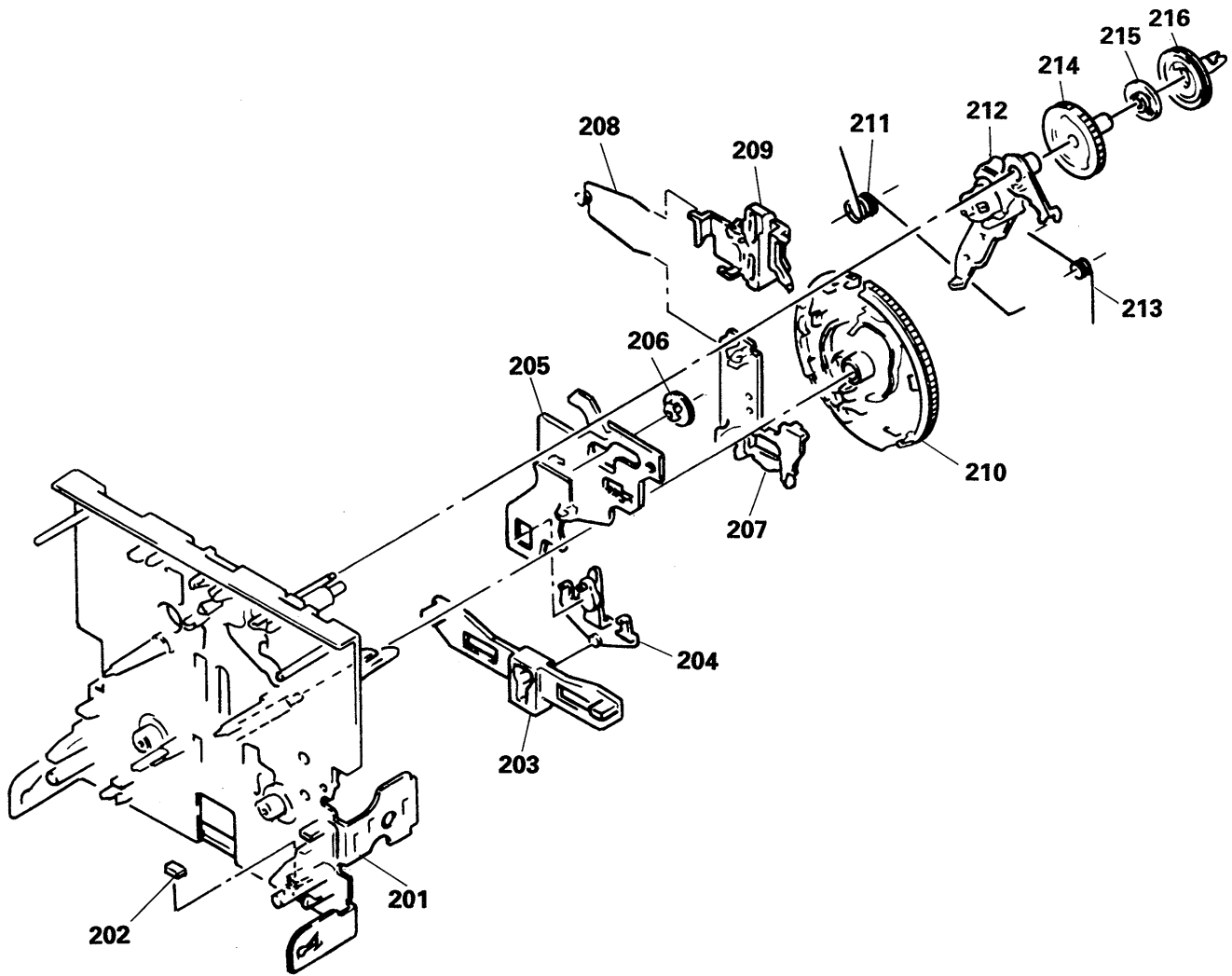

Ref.No.	Part No.	Description	Remarks	Ref.No.	Part No.	Description	Remarks
201	X-3363-790-1	CHASSIS ASSY, MECHANICAL		209	3-359-429-01	SLIDER (BRAKE PLATE)	
202	3-359-469-01	SPACER		210	3-359-420-01	GEAR (CAM GEAR)	
* 203	3-359-425-01	SLIDER (REVERSE SLIDER)		211	3-359-456-01	SPRING (TRIGGER SPRING), TORSION	
204	3-359-426-01	LEVER (REVERSE LEVER)		212	X-3359-405-1	LEVER (FR ARM) ASSY	
* 205	3-359-415-01	SLIDER (TRIGGER SLIDER)		213	3-359-453-01	SPRING (FR ARM), TORSION	
206	3-359-448-01	GEAR (TRIGGER)		214	3-359-419-01	GEAR (FR GEAR)	
* 207	3-359-427-01	SLIDER (LEVERSE SLIDER)		215	3-359-421-01	CLUTCH (REEL DISK)	
208	3-359-454-01	SPRING, TORSION		216	3-359-418-01	PULLEY (FR PULLEY)	

SECTION 7 ELECTRICAL PARTS LIST

NOTE:

The components identified by mark Δ or dotted line with mark Δ are critical for safety.
Replace only with part number specified.

Les composants identifiés par une marque Δ sont critiques pour la sécurité.
Ne les remplacer que par une pièce portant le numéro spécifié.

When indicating parts by reference number, please include the board name.

- G : Germany Model
- AUS : Australian Model
- EA : Saudi Arabia Model
- EE : East European Model

- Due to standardization, replacements in the parts list may be different from the parts specified in the diagrams or the components used on the set.
- -XX, -X mean standardized parts, so they may have some difference from the original one.
- RESISTORS
All resistors are in ohms
METAL : Metal-film resistor
METAL OXIDE : Metal Oxide-film resistor
F : nonflammable

- Items marked "*" are not stocked since they are seldom required for routine service. Some delay should be anticipated when ordering these items.
- SEMICONDUCTORS
In each case, u : μ , for example :
uA...: μ A..., uPA...: μ PA...,
uPB...: μ PB..., uPC...: μ PC...,
uPD...: μ PD...
- CAPACITORS
uF : μ F
- COILS
uH : μ H

LEAF SW(A)	LEAF SW(B)	AUDIO(RA12A)
-------------------	-------------------	---------------------

Ref. No.	Part No.	Description	Remarks	Ref. No.	Part No.	Description	Remarks
*	1-634-841-14	LEAF SW(A) BOARD (DECK A) *****		S83	1-571-281-21	SWITCH, LEAF (METAL)	
		< CONNECTOR >		S84	1-571-281-21	SWITCH, LEAF (REC A)	
				S85	1-571-281-21	SWITCH, LEAF (REC B)	
				S86	1-571-281-21	SWITCH, LEAF (HALF)	

* CNP81	1-568-852-11	SOCKET, CONNECTOR 9P < IC >		*	A-2006-399-A	AUDIO BOARD(RA12A), COMPLETE (DECK A) *****	
						< CAPACITOR >	
IC81	8-719-710-03	DI ODE NJL5165K-B < RESISTOR >		C11	1-163-131-00	CERAMIC CHIP 390PF 5% 50V	
				C12	1-136-157-00	FILM 0.022uF 5% 50V	
R84	1-249-417-11	CARBON 1K 5% 1/4W		C13	1-124-234-00	ELECT 22uF 20% 16V	
R85	1-249-408-11	CARBON 180 5% 1/4W		C18	1-163-117-00	CERAMIC CHIP 100PF 5% 50V	
		< SWITCH >		C21	1-163-131-00	CERAMIC CHIP 390PF 5% 50V	
S81	1-571-958-11	SWITCH, PUSH (1 KEY) (STOP)		C22	1-136-157-00	FILM 0.022uF 5% 50V	
S82	1-571-281-21	SWITCH, LEAF (70EQ)		C23	1-124-234-00	ELECT 22uF 20% 16V	
S86	1-571-281-21	SWITCH, LEAF (HALF)		C28	1-163-117-00	CERAMIC CHIP 100PF 5% 50V	
*****				C31	1-124-234-00	ELECT 22uF 20% 16V	
				C32	1-124-234-00	ELECT 22uF 20% 16V	
*	1-634-841-14	LEAF SW(B) BOARD (DECK B) *****		C72	1-124-499-11	ELECT, NONPOLAR 1uF 20% 50V	
		< CONNECTOR >				< CONNECTOR >	
* CNP81	1-568-852-11	SOCKET, CONNECTOR 9P < IC >		* CNJ31	1-580-782-11	CONNECTOR, BOARD TO BOARD	
				* CNJ72	1-580-411-11	SOCKET, CONNECTOR 4P	
				* CNP32	1-580-772-11	PIN, CONNECTOR (PC BOARD) 4P	
				* CNP71	1-564-719-11	PIN, CONNECTOR (SMALL TYPE) 3P	
						< IC >	
IC81	8-719-710-03	DI ODE NJL5165K-B < RESISTOR >		IC31	8-759-106-02	IC uPC4570G2	
						< JUMPER WIRE >	
R81	1-249-414-11	CARBON 560 5% 1/4W		JW1	1-216-295-00	METAL CHIP 0 5% 1/10W	
R82	1-247-818-11	CARBON 300 5% 1/4W		JW51	1-216-296-00	METAL CHIP 0 5% 1/8W	
R83	1-247-834-11	CARBON 1.3K 5% 1/4W		JW52	1-216-296-00	METAL CHIP 0 5% 1/8W	
R84	1-249-417-11	CARBON 1K 5% 1/4W		JW53	1-216-296-00	METAL CHIP 0 5% 1/8W	
R85	1-249-408-11	CARBON 180 5% 1/4W		JW54	1-216-296-00	METAL CHIP 0 5% 1/8W	
		< SWITCH >				< TRANSISTOR >	
S81	1-571-958-11	SWITCH, PUSH (1 KEY) (STOP)		Q71	8-729-602-36	TRANSISTOR 2SA1602-F	
S82	1-571-281-21	SWITCH, LEAF (70EQ)					

AUDIO(RA12A)

AUDIO(RB22A)

Ref. No.	Part No.	Description	Remarks
< RESISTOR >			
R11	1-216-099-00	METAL CHIP 120K 5%	1/10W
R12	1-216-025-00	METAL CHIP 100 5%	1/10W
R13	1-216-100-00	METAL GLAZE 130K 5%	1/10W
R14	1-216-067-00	METAL CHIP 5.6K 5%	1/10W
R21	1-216-099-00	METAL CHIP 120K 5%	1/10W
R22	1-216-025-00	METAL CHIP 100 5%	1/10W
R23	1-216-100-00	METAL GLAZE 130K 5%	1/10W
R24	1-216-067-00	METAL CHIP 5.6K 5%	1/10W
R31	1-216-033-00	METAL CHIP 220 5%	1/10W
R32	1-216-033-00	METAL CHIP 220 5%	1/10W
R71	1-216-082-00	METAL GLAZE 24K 5%	1/10W
R72	1-216-081-00	METAL CHIP 22K 5%	1/10W
R73	1-216-089-00	METAL CHIP 47K 5%	1/10W
R74	1-216-089-00	METAL CHIP 47K 5%	1/10W
< VARIABLE RESISTOR >			
RV11	1-238-012-11	RES, ADJ, CARBON 1K (PB LEVEL L)	
RV21	1-238-012-11	RES, ADJ, CARBON 1K (PB LEVEL R)	
RV71	1-238-016-11	RES, ADJ, CARBON 10K (NORMAL SPEED)	
RV72	1-238-016-11	RES, ADJ, CARBON 10K (HIGH SPEED)	

*	A-2006-400-A	AUDIO BOARD(RB22A), COMPLETE (DECK B)	

< CAPACITOR >			
C11	1-163-131-00	CERAMIC CHIP 390PF 5%	50V
C12	1-136-157-00	FILM 0.022uF 5%	50V
C13	1-124-234-00	ELECT 22uF 20%	16V
C14	1-136-273-91	FILM 75PF 5%	630V
C15	1-164-080-11	CERAMIC 390PF 10%	50V
C17	1-163-103-00	CERAMIC CHIP 27PF 5%	50V
C18	1-163-117-00	CERAMIC CHIP 100PF 5%	50V
C21	1-163-131-00	CERAMIC CHIP 390PF 5%	50V
C22	1-136-157-00	FILM 0.022uF 5%	50V
C23	1-124-234-00	ELECT 22uF 20%	16V
C24	1-136-273-91	FILM 75PF 5%	630V
C25	1-164-080-11	CERAMIC 390PF 10%	50V
C27	1-163-103-00	CERAMIC CHIP 27PF 5%	50V
C28	1-163-117-00	CERAMIC CHIP 100PF 5%	50V
C31	1-124-234-00	ELECT 22uF 20%	16V
C32	1-124-234-00	ELECT 22uF 20%	16V
C33	1-124-234-00	ELECT 22uF 20%	16V
C51	1-163-019-00	CERAMIC CHIP 0.0068uF 10%	50V
C52	1-163-019-00	CERAMIC CHIP 0.0068uF 10%	50V
C53	1-163-022-00	CERAMIC CHIP 0.012uF 10%	50V
C54	1-136-559-11	FILM 0.0047uF 5%	630V
C56	1-164-505-11	CERAMIC CHIP 2.2uF	16V
C57	1-164-346-11	CERAMIC CHIP 1uF	16V

Ref. No.	Part No.	Description	Remarks
C58	1-163-024-00	CERAMIC CHIP 0.018uF	10% 50V
C72	1-124-499-11	ELECT, NONPOLAR 1uF	20% 50V
< CONNECTOR >			
* CNJ31	1-580-782-11	CONNECTOR, BOARD TO BOARD	
* CNJ33	1-580-782-11	CONNECTOR, BOARD TO BOARD	
* CNJ72	1-580-411-11	SOCKET, CONNECTOR 4P	
* CNP32	1-580-781-11	PIN, CONNECTOR (PC BOARD) 7P	
* CNP71	1-564-719-11	PIN, CONNECTOR (SMALL TYPE) 3P	
< DIODE >			
D31	8-719-988-62	DIODE 1SS355	
< IC >			
IC31	8-759-106-02	IC uPC4570G2	
< JUMPER WIRE >			
JW1	1-216-296-00	METAL CHIP 0 5%	1/8W
JW2	1-216-295-00	METAL CHIP 0 5%	1/10W
JW3	1-216-295-00	METAL CHIP 0 5%	1/10W
JW4	1-216-295-00	METAL CHIP 0 5%	1/10W
JW5	1-216-295-00	METAL CHIP 0 5%	1/10W
JW6	1-216-295-00	METAL CHIP 0 5%	1/10W
JW7	1-216-295-00	METAL CHIP 0 5%	1/10W
JW52	1-216-296-00	METAL CHIP 0 5%	1/8W
JW53	1-216-296-00	METAL CHIP 0 5%	1/8W
JW54	1-216-296-00	METAL CHIP 0 5%	1/8W
JW55	1-216-296-00	METAL CHIP 0 5%	1/8W
JW56	1-216-296-00	METAL CHIP 0 5%	1/8W
JW57	1-216-296-00	METAL CHIP 0 5%	1/8W
JW58	1-216-296-00	METAL CHIP 0 5%	1/8W
JW59	1-216-296-00	METAL CHIP 0 5%	1/8W
JW60	1-216-296-00	METAL CHIP 0 5%	1/8W
JW61	1-216-296-00	METAL CHIP 0 5%	1/8W
< COIL >			
L11	1-410-780-11	INDUCTOR 27mH	
L21	1-410-780-11	INDUCTOR 27mH	
< TRANSISTOR >			
Q51	8-729-808-01	TRANSISTOR 2SD1622-S	
Q52	8-729-808-01	TRANSISTOR 2SD1622-S	
Q53	8-729-808-01	TRANSISTOR 2SD1622-S	
Q71	8-729-602-36	TRANSISTOR 2SA1602-F	
< RESISTOR >			
R11	1-216-099-00	METAL CHIP 120K 5%	1/10W
R12	1-216-025-00	METAL CHIP 100 5%	1/10W
R13	1-216-100-00	METAL GLAZE 130K 5%	1/10W

When indicating parts by reference number, please include the board name.

AUDIO(RB22A)

MAIN

Ref. No.	Part No.	Description	Remarks	Ref. No.	Part No.	Description	Remarks
R14	1-216-067-00	METAL CHIP	5.6K 5% 1/10W	C105	1-130-475-00	MYLAR 0.0022uF 5% 50V(AEP, UK, G, EE)	
R15	1-249-430-11	CARBON	12K 5% 1/4W	C105	1-131-587-11	TANTALUM 0.68uF 5% 35V	
R21	1-216-099-00	METAL CHIP	120K 5% 1/10W			(Canadian, AUS, E, EA)	
R22	1-216-025-00	METAL CHIP	100 5% 1/10W	C106	1-126-059-11	ELECT 10uF	20% 50V
R23	1-216-100-00	METAL GLAZE	130K 5% 1/10W	C107	1-136-174-00	FILM 0.56uF 5% 50V(AEP, UK, G, EE)	
R24	1-216-067-00	METAL CHIP	5.6K 5% 1/10W	C108	1-136-171-00	FILM 0.33uF 5% 50V(AEP, UK, G, EE)	
R25	1-249-430-11	CARBON	12K 5% 1/4W	C109	1-126-059-11	ELECT 10uF	20% 50V
R31	1-216-033-00	METAL CHIP	220 5% 1/10W	C110	1-163-117-00	CERAMIC CHIP 100PF	5% 50V
R32	1-216-033-00	METAL CHIP	220 5% 1/10W	C111	1-164-005-11	CERAMIC CHIP 0.47uF	25V
R41	1-249-393-11	CARBON	10 5% 1/4W	C112	1-126-300-11	ELECT 0.47uF	20% 50V
R42	1-249-393-11	CARBON	10 5% 1/4W	C113	1-163-117-00	CERAMIC CHIP 100PF	5% 50V
R51	1-216-075-00	METAL CHIP	12K 5% 1/10W	C114	1-126-059-11	ELECT 10uF	20% 50V
R52	1-216-075-00	METAL CHIP	12K 5% 1/10W	C201	1-136-157-00	FILM 0.022uF	5% 50V
R53	1-216-073-00	METAL CHIP	10K 5% 1/10W	C202	1-164-161-11	CERAMIC CHIP 0.0022uF	10% 100V
R54	1-216-309-00	METAL CHIP	5.6 5% 1/10W			(AEP, UK, G, EE)	
R55	1-216-309-00	METAL CHIP	5.6 5% 1/10W	C202	1-163-141-00	CERAMIC CHIP 0.001uF	5% 50V
R56	1-216-298-00	METAL CHIP	2.2 5% 1/10W			(Canadian, AUS, E, EA)	
R71	1-216-082-00	METAL GLAZE	24K 5% 1/10W	C203	1-163-141-00	CERAMIC CHIP 0.001uF	5% 50V
R72	1-216-081-00	METAL CHIP	22K 5% 1/10W	C204	1-130-475-00	MYLAR 0.0022uF 5% 50V(AEP, UK, G, EE)	
R73	1-216-089-00	METAL CHIP	47K 5% 1/10W	C205	1-130-475-00	MYLAR 0.0022uF 5% 50V(AEP, UK, G, EE)	
R74	1-216-089-00	METAL CHIP	47K 5% 1/10W	C205	1-131-587-11	TANTALUM 0.68uF 5% 35V	
		< VARIABLE RESISTOR >				(Canadian, AUS, E, EA)	
RV11	1-238-012-11	RES, ADJ, CARBON 1K	(PB LEVEL L)	C206	1-126-059-11	ELECT 10uF	20% 50V
RV12	1-238-551-11	RES, ADJ, CARBON 220K	(REC BIAS L)	C207	1-136-174-00	FILM 0.56uF 5% 50V(AEP, UK, G, EE)	
RV21	1-238-012-11	RES, ADJ, CARBON 1K	(PB LEVEL R)	C208	1-136-171-00	FILM 0.33uF 5% 50V(AEP, UK, G, EE)	
RV22	1-238-551-11	RES, ADJ, CARBON 220K	(REC BIAS R)	C209	1-126-059-11	ELECT 10uF	20% 50V
RV71	1-238-016-11	RES, ADJ, CARBON 10K	(NORMAL SPEED)	C210	1-163-117-00	CERAMIC CHIP 100PF	5% 50V
RV72	1-238-016-11	RES, ADJ, CARBON 10K	(HIGH SPEED)	C211	1-164-005-11	CERAMIC CHIP 0.47uF	25V
		< RELAY >		C212	1-126-300-11	ELECT 0.47uF	20% 50V
RY31	1-515-726-11	RELAY		C213	1-163-117-00	CERAMIC CHIP 100PF	5% 50V
		< TRANSFORMER >		C214	1-126-059-11	ELECT 10uF	20% 50V
T51	1-406-419-11	COIL, BIAS OSCILLATION		C601	1-126-059-11	ELECT 10uF 20% 50V(AEP, UK, G, EE)	
*****				C601	1-124-994-11	ELECT 100uF 20% 10V(Canadian, AUS, E, EA)	
*	A-2006-711-A	MAIN BOARD, COMPLETE	(Canadian, AUS, E, EA)	C602	1-126-059-11	ELECT 10uF 20% 50V(AEP, UK, G, EE)	
*	A-2006-714-A	MAIN BOARD, COMPLETE	(AEP, G, EE)	C602	1-124-994-11	ELECT 100uF 20% 10V(Canadian, AUS, E, EA)	
*	A-2006-791-A	MAIN BOARD, COMPLETE	(UK)	C603	1-126-059-11	ELECT 10uF	20% 50V
		*****		C604	1-126-059-11	ELECT 10uF	20% 50V
		< CAPACITOR >		C605	1-164-232-11	CERAMIC CHIP 0.01uF	50V
C101	1-136-157-00	FILM 0.022uF	5% 50V	C606	1-164-232-11	CERAMIC CHIP 0.01uF	50V
C102	1-164-161-11	CERAMIC CHIP 0.0022uF	10% 100V	C607	1-164-346-11	CERAMIC CHIP 1uF	16V
			(AEP, UK, G, EE)	C608	1-126-161-11	ELECT 2.2uF	20% 50V
C102	1-163-141-00	CERAMIC CHIP 0.001uF	5% 50V	C609	1-163-141-00	CERAMIC CHIP 0.001uF	5% 50V
			(Canadian, AUS, E, EA)	C610	1-163-038-00	CERAMIC CHIP 0.1uF	25V
C103	1-163-141-00	CERAMIC CHIP 0.001uF	5% 50V	C611	1-163-117-00	CERAMIC CHIP 100PF	5% 50V
C104	1-130-475-00	MYLAR 0.0022uF	5% 50V(AEP, UK, G, EE)	C612	1-162-568-11	CERAMIC CHIP 0.33uF	10% 16V
				C613	1-164-346-11	CERAMIC CHIP 1uF	16V
				C614	1-163-037-11	CERAMIC CHIP 0.022uF	10% 25V
				C615	1-163-038-00	CERAMIC CHIP 0.1uF	25V
				C616	1-163-125-00	CERAMIC CHIP 220PF	5% 50V
				C617	1-126-101-11	ELECT 100uF	20% 16V
				C618	1-163-038-00	CERAMIC CHIP 0.1uF	25V

When indicating parts by reference number, please include the board name.

MAIN

Ref. No.	Part No.	Description	Remarks	Ref. No.	Part No.	Description	Remarks	
C619	1-163-141-00	CERAMIC CHIP	0.001uF 5%	50V	D610	8-719-400-18	DIODE MA152WK	
C620	1-164-232-11	CERAMIC CHIP	0.01uF	50V	D611	8-719-400-18	DIODE MA152WK	
C621	1-164-232-11	CERAMIC CHIP	0.01uF	50V	D612	8-719-400-16	DIODE MA153	
C622	1-124-994-11	ELECT	100uF	20% 10V			< IC >	
C623	1-163-038-00	CERAMIC CHIP	0.1uF	25V	IC101	8-759-300-71	IC HD14053BFP	
C624	1-124-994-11	ELECT	100uF	20% 10V	IC102	8-752-037-90	IC CXA1331M (AEP, UK, G, EE)	
C625	1-163-141-00	CERAMIC CHIP	0.001uF	5%	50V	IC102	8-752-050-13	IC CXA1101M (Canadian, AUS, E, EA)
C626	1-163-141-00	CERAMIC CHIP	0.001uF	5%	50V	IC103	8-752-055-60	IC CXA1578M
C627	1-163-037-11	CERAMIC CHIP	0.022uF	10%	25V	IC104	8-759-996-43	IC RC4558PS
C628	1-163-038-00	CERAMIC CHIP	0.1uF	25V	IC105	8-759-516-47	IC CD4066BCM	
C629	1-163-038-00	CERAMIC CHIP	0.1uF	25V	IC601	8-759-058-40	IC M50944-128FP	
C630	1-163-038-00	CERAMIC CHIP	0.1uF	25V	IC602	8-759-636-67	IC M50925-482FP	
C631	1-163-038-00	CERAMIC CHIP	0.1uF	25V	IC603	8-759-207-05	IC TA7272P	
C862	1-163-038-00	CERAMIC CHIP	0.1uF	25V	IC604	8-759-996-43	IC RC4558PS	
C6008	1-126-301-11	ELECT	1uF	20%	50V	IC605	8-759-516-41	IC CD4052BCM
C6009	1-164-232-11	CERAMIC CHIP	0.01uF	50V			< COIL >	
C6010	1-163-038-00	CERAMIC CHIP	0.1uF	25V	L6001	1-410-482-31	INDUCTOR 100uH	
C6011	1-163-129-00	CERAMIC CHIP	330PF	5%	50V	L6002	1-408-777-00	INDUCTOR CHIP 10uH
C6012	1-163-129-00	CERAMIC CHIP	330PF	5%	50V		< TRANSISTOR >	
C6013	1-126-023-11	ELECT	100uF	20%	16V	Q101	8-729-421-22	TRANSISTOR UN2211
C6020	1-163-141-00	CERAMIC CHIP	0.001uF	5%	50V	Q102	8-729-805-40	TRANSISTOR 2SC3900
C6021	1-163-141-00	CERAMIC CHIP	0.001uF	5%	50V	Q201	8-729-421-22	TRANSISTOR UN2211
C6022	1-126-059-11	ELECT	10uF	20%	50V	Q202	8-729-805-40	TRANSISTOR 2SC3900
C6026	1-163-125-00	CERAMIC CHIP	220PF	5%	50V	Q601	8-729-805-65	TRANSISTOR 2SA1344 (AEP, UK, G, EE)
C6027	1-163-125-00	CERAMIC CHIP	220PF	5%	50V	Q602	8-729-805-65	TRANSISTOR 2SA1344 (AEP, UK, G, EE)
C6029	1-163-141-00	CERAMIC CHIP	0.001uF	5%	50V	Q603	8-729-421-22	TRANSISTOR UN2211 (AEP, UK, G, EE)
C6030	1-163-141-00	CERAMIC CHIP	0.001uF	5%	50V	Q604	8-729-805-65	TRANSISTOR 2SA1344
C6031	1-163-038-00	CERAMIC CHIP	0.1uF	25V	Q605	8-729-805-69	TRANSISTOR 2SA1341	
C6032	1-163-141-00	CERAMIC CHIP	0.001uF	5%	50V	Q607	8-729-805-65	TRANSISTOR 2SA1344
C6035	1-163-037-11	CERAMIC CHIP	0.022uF	10%	25V	Q608	8-729-805-65	TRANSISTOR 2SA1344
		< CONNECTOR >			Q609	8-729-421-22	TRANSISTOR UN2211	
CN601	1-573-101-11	SOCKET, CONNECTOR 9P			Q611	8-729-805-65	TRANSISTOR 2SA1344	
CN602	1-580-783-11	CONNECTOR, BOARD TO BOARD			Q612	8-729-421-22	TRANSISTOR UN2211	
CN603	1-573-101-11	SOCKET, CONNECTOR 9P			Q613	8-729-421-22	TRANSISTOR UN2211	
CN604	1-580-783-11	CONNECTOR, BOARD TO BOARD			Q616	8-729-820-86	TRANSISTOR 2SB1121-ST	
* CN605	1-568-862-11	SOCKET, CONNECTOR 19P			Q617	8-729-820-86	TRANSISTOR 2SB1121-ST	
CN606	1-568-795-11	SOCKET, CONNECTOR 12P			Q619	8-729-602-21	TRANSISTOR 2SC4154	
CN607	1-580-783-11	CONNECTOR, BOARD TO BOARD			Q620	8-729-602-21	TRANSISTOR 2SC4154	
		< DIODE >					< RESISTOR >	
D601	8-719-402-00	DIODE MA3091 (AEP, UK, G, EE)			R101	1-216-089-00	METAL CHIP 47K 5% 1/10W	
D601	8-719-401-90	DIODE MA3082 (Canadian, AUS, E, EA)			R102	1-216-089-00	METAL CHIP 47K 5% 1/10W	
D602	8-719-400-18	DIODE MA152WK			R103	1-216-055-00	METAL CHIP 1.8K 5% 1/10W	
D603	8-719-400-18	DIODE MA152WK			R104	1-216-061-00	METAL CHIP 3.3K 5% 1/10W	
D604	8-719-401-90	DIODE MA3082 (Canadian, AUS, E, EA)			R105	1-216-105-00	METAL CHIP 220K 5% 1/10W	
D605	8-719-401-51	DIODE MA3056L			R106	1-216-057-00	METAL CHIP 2.2K 5% 1/10W ((AEP, UK, G, EE)	
D606	8-719-210-33	DIODE EC10DS2						
D607	8-719-210-33	DIODE EC10DS2						
D608	8-719-210-33	DIODE EC10DS2						

When indicating parts by reference number, please include the board name.

MAIN

Ref. No.	Part No.	Description	Remarks	Ref. No.	Part No.	Description	Remarks
R106	1-216-056-00	METAL GLAZE	2K 5% 1/10W (Canadian, AUS, E, EA)	R610	1-216-082-00	METAL GLAZE	24K 5% 1/10W
R107	1-216-082-00	METAL GLAZE	24K 5% 1/10W(AEP, UK, G, EE)	R611	1-216-081-00	METAL CHIP	22K 5% 1/10W
R108	1-216-043-00	METAL CHIP	560 5% 1/10W(AEP, UK, G, EE)	R612	1-216-081-00	METAL CHIP	22K 5% 1/10W
R109	1-216-073-00	METAL CHIP	10K 5% 1/10W(AEP, UK, G, EE)	R615	1-216-057-00	METAL CHIP	2.2K 5% 1/10W
R109	1-216-057-00	METAL CHIP	2.2K 5% 1/10W (Canadian, AUS, E, EA)	R616	1-216-097-00	METAL CHIP	100K 5% 1/10W
R110	1-216-057-00	METAL CHIP	2.2K 5% 1/10W	R617	1-216-097-00	METAL CHIP	100K 5% 1/10W
R111	1-216-097-00	METAL CHIP	100K 5% 1/10W	R618	1-216-097-00	METAL CHIP	100K 5% 1/10W
R112	1-216-065-00	METAL CHIP	4.7K 5% 1/10W	R619	1-216-065-00	METAL CHIP	4.7K 5% 1/10W
R113	1-216-089-00	METAL CHIP	47K 5% 1/10W	R620	1-216-097-00	METAL CHIP	100K 5% 1/10W
R114	1-216-058-00	METAL GLAZE	2.4K 5% 1/10W	R621	1-216-065-00	METAL CHIP	4.7K 5% 1/10W
R115	1-216-081-00	METAL CHIP	22K 5% 1/10W	R623	1-216-107-00	METAL CHIP	270K 5% 1/10W
R120	1-216-085-00	METAL CHIP	33K 5% 1/10W	R624	1-216-037-00	METAL CHIP	330 5% 1/10W
R201	1-216-089-00	METAL CHIP	47K 5% 1/10W	R625	1-216-060-00	METAL GLAZE	3K 5% 1/10W
R202	1-216-089-00	METAL CHIP	47K 5% 1/10W	R626	1-216-072-00	METAL CHIP	9.1K 5% 1/10W
R203	1-216-055-00	METAL CHIP	1.8K 5% 1/10W	R628	1-216-073-00	METAL CHIP	10K 5% 1/10W
R204	1-216-061-00	METAL CHIP	3.3K 5% 1/10W	R629	1-216-057-00	METAL CHIP	2.2K 5% 1/10W
R205	1-216-105-00	METAL CHIP	220K 5% 1/10W	R630	1-216-081-00	METAL CHIP	22K 5% 1/10W
R206	1-216-057-00	METAL CHIP	2.2K 5% 1/10W(AEP, UK, G, EE)	R631	1-216-081-00	METAL CHIP	22K 5% 1/10W
R206	1-216-056-00	METAL GLAZE	2K 5% 1/10W (Canadian, AUS, E, EA)	R634	1-216-081-00	METAL CHIP	22K 5% 1/10W
R207	1-216-082-00	METAL GLAZE	24K 5% 1/10W(AEP, UK, G, EE)	R635	1-216-081-00	METAL CHIP	22K 5% 1/10W
R208	1-216-043-00	METAL CHIP	560 5% 1/10W(AEP, UK, G, EE)	R636	1-216-081-00	METAL CHIP	22K 5% 1/10W
R209	1-216-073-00	METAL CHIP	10K 5% 1/10W(AEP, UK, G, EE)	R637	1-216-081-00	METAL CHIP	22K 5% 1/10W
R209	1-216-057-00	METAL CHIP	2.2K 5% 1/10W (Canadian, AUS, E, EA)	R638	1-216-081-00	METAL CHIP	22K 5% 1/10W
R210	1-216-057-00	METAL CHIP	2.2K 5% 1/10W	R639	1-216-057-00	METAL CHIP	2.2K 5% 1/10W
R211	1-216-097-00	METAL CHIP	100K 5% 1/10W	R640	1-216-057-00	METAL CHIP	2.2K 5% 1/10W
R212	1-216-065-00	METAL CHIP	4.7K 5% 1/10W	R641	1-216-065-00	METAL CHIP	4.7K 5% 1/10W
R213	1-216-089-00	METAL CHIP	47K 5% 1/10W	R642	1-216-089-00	METAL CHIP	47K 5% 1/10W
R214	1-216-058-00	METAL GLAZE	2.4K 5% 1/10W	R643	1-216-089-00	METAL CHIP	47K 5% 1/10W
R215	1-216-081-00	METAL CHIP	22K 5% 1/10W	R644	1-216-025-00	METAL CHIP	100 5% 1/10W
R220	1-216-085-00	METAL CHIP	33K 5% 1/10W	R645	1-216-089-00	METAL CHIP	47K 5% 1/10W
R601	1-216-081-00	METAL CHIP	22K 5% 1/10W	R646	1-216-081-00	METAL CHIP	22K 5% 1/10W
R602	1-216-081-00	METAL CHIP	22K 5% 1/10W	R647	1-216-025-00	METAL CHIP	100 5% 1/10W
R603	1-216-057-00	METAL CHIP	2.2K 5% 1/10W(AEP, UK, G, EE)	R648	1-216-025-00	METAL CHIP	100 5% 1/10W
R603	1-216-073-00	METAL CHIP	10K 5% 1/10W (Canadian, AUS, E, EA)	R649	1-216-025-00	METAL CHIP	100 5% 1/10W
R605	1-216-081-00	METAL CHIP	22K 5% 1/10W(AEP, UK, G, EE)	R650	1-216-121-00	METAL CHIP	1M 5% 1/10W
R605	1-216-089-00	METAL CHIP	47K 5% 1/10W (Canadian, AUS, E, EA)	R651	1-216-081-00	METAL CHIP	22K 5% 1/10W
R606	1-216-081-00	METAL CHIP	22K 5% 1/10W(AEP, UK, G, EE)	R652	1-216-081-00	METAL CHIP	22K 5% 1/10W
R606	1-216-089-00	METAL CHIP	47K 5% 1/10W (Canadian, AUS, E, EA)	R653	1-216-073-00	METAL CHIP	10K 5% 1/10W
R607	1-216-081-00	METAL CHIP	22K 5% 1/10W(AEP, UK, G, EE)	R654	1-216-073-00	METAL CHIP	10K 5% 1/10W
R607	1-216-073-00	METAL CHIP	10K 5% 1/10W (Canadian, AUS, E, EA)	R655	1-216-121-00	METAL CHIP	1M 5% 1/10W
R608	1-216-049-00	METAL CHIP	1K 5% 1/10W(AEP, UK, G, EE)	R656	1-216-073-00	METAL CHIP	10K 5% 1/10W
R608	1-216-088-00	METAL CHIP	43K 5% 1/10W (Canadian, AUS, E, EA)	R661	1-216-083-00	METAL CHIP	27K 5% 1/10W
R609	1-216-083-00	METAL CHIP	27K 5% 1/10W(AEP, UK, G, EE)	R662	1-216-083-00	METAL CHIP	27K 5% 1/10W
				R663	1-216-073-00	METAL CHIP	10K 5% 1/10W
				R664	1-216-045-00	METAL CHIP	680 5% 1/10W
				R665	1-216-073-00	METAL CHIP	10K 5% 1/10W
				R666	1-216-045-00	METAL CHIP	680 5% 1/10W
				R667	1-216-025-00	METAL CHIP	100 5% 1/10W
				R668	1-216-090-00	METAL CHIP	51K 5% 1/10W
				R669	1-216-089-00	METAL CHIP	47K 5% 1/10W

When indicating parts by reference number, please include the board name.

MAIN

PANEL

Ref. No.	Part No.	Description	Remarks
R670	1-216-084-00	METAL CHIP	30K 5% 1/10W
R671	1-216-090-00	METAL CHIP	51K 5% 1/10W
R672	1-216-065-00	METAL CHIP	4.7K 5% 1/10W
R673	1-216-080-00	METAL CHIP	20K 5% 1/10W
R674	1-216-083-00	METAL CHIP	27K 5% 1/10W
R675	1-216-080-00	METAL CHIP	20K 5% 1/10W
R676	1-216-065-00	METAL CHIP	4.7K 5% 1/10W
R677	1-216-089-00	METAL CHIP	47K 5% 1/10W
R678	1-216-084-00	METAL CHIP	30K 5% 1/10W
R679	1-216-083-00	METAL CHIP	27K 5% 1/10W
R680	1-216-090-00	METAL CHIP	51K 5% 1/10W
R681	1-216-090-00	METAL CHIP	51K 5% 1/10W
R682	1-216-025-00	METAL CHIP	100 5% 1/10W
R686	1-216-063-00	METAL CHIP	3.9K 5% 1/10W
R687	1-216-081-00	METAL CHIP	22K 5% 1/10W
R690	1-216-025-00	METAL CHIP	100 5% 1/10W
R691	1-216-057-00	METAL CHIP	2.2K 5% 1/10W
R692	1-216-081-00	METAL CHIP	22K 5% 1/10W
R693	1-216-025-00	METAL CHIP	100 5% 1/10W
R696	1-216-081-00	METAL CHIP	22K 5% 1/10W
R698	1-216-029-00	METAL CHIP	150 5% 1/10W
R699	1-216-081-00	METAL CHIP	22K 5% 1/10W
R700	1-216-073-00	METAL CHIP	10K 5% 1/10W
R6001	1-216-081-00	METAL CHIP	22K 5% 1/10W
R6002	1-216-089-00	METAL CHIP	47K 5% 1/10W
R6004	1-216-089-00	METAL CHIP	47K 5% 1/10W
R6005	1-216-089-00	METAL CHIP	47K 5% 1/10W
R6010	1-216-049-00	METAL CHIP	1K 5% 1/10W
R6011	1-216-298-00	METAL CHIP	2.2 5% 1/10W
R6012	1-216-298-00	METAL CHIP	2.2 5% 1/10W
R6013	1-216-298-00	METAL CHIP	2.2 5% 1/10W
R6014	1-216-298-00	METAL CHIP	2.2 5% 1/10W
R6015	1-216-298-00	METAL CHIP	2.2 5% 1/10W
R6016	1-216-298-00	METAL CHIP	2.2 5% 1/10W
R6017	1-216-298-00	METAL CHIP	2.2 5% 1/10W
R6018	1-216-298-00	METAL CHIP	2.2 5% 1/10W
< VARIABLE RESISTOR >			
RV101	1-241-136-11	RES, ADJ, CARBON 10K (REC LEVEL L)	
RV201	1-241-136-11	RES, ADJ, CARBON 10K (REC LEVEL R)	
< SWITCH >			
S601	1-554-303-21	SWITCH, TACTILE (ADJ. HIGH SPEED)	
< TEST PIN >			
* TP601	1-564-517-11	PLUG, CONNECTOR 2P	

Ref. No.	Part No.	Description	Remarks
< CRYSTAL >			
X601	1-577-358-21	VIBRATOR, CERAMIC (4MHz)	

*	A-2006-712-A	PANEL BOARD, COMPLETE (Canadian, AUS, E, EA)	
*	A-2006-715-A	PANEL BOARD, COMPLETE (AEP, G, EE)	
*	A-2006-792-A	PANEL BOARD, COMPLETE (UK)	

< CAPACITOR >			
C351	1-126-163-11	ELECT	4.7uF 20% 50V
C352	1-124-638-11	ELECT	22uF 20% 10V
C353	1-164-232-11	CERAMIC CHIP	0.01uF 50V
C354	1-164-232-11	CERAMIC CHIP	0.01uF 50V
C355	1-164-232-11	CERAMIC CHIP	0.01uF 50V
C356	1-163-125-00	CERAMIC CHIP	220PF 5% 50V
< CONNECTOR >			
CN351	1-568-795-11	SOCKET, CONNECTOR 12P	
< DIODE >			
D301	8-719-301-38	LED SEL2210S-C (DUBBING MODE)	
D302	8-719-301-38	LED SEL2210S-C (CD SYNCHRO)	
< FLUORESCENT INDICATOR >			
FL351	1-519-708-11	INDICATOR TUBE, FLUORESCENT	
< IC >			
IC351	8-759-323-35	IC HD614023-FA93	
< JUMPER WIRE >			
JW302	1-216-295-00	METAL CHIP	0 5% 1/10W
< RESISTOR >			
R351	1-216-029-00	METAL CHIP	150 5% 1/10W
R352	1-216-033-00	METAL CHIP	220 5% 1/10W
R353	1-216-037-00	METAL CHIP	330 5% 1/10W
R354	1-216-041-00	METAL CHIP	470 5% 1/10W
R355	1-216-045-00	METAL CHIP	680 5% 1/10W
R356	1-216-049-00	METAL CHIP	1K 5% 1/10W
R357	1-216-067-00	METAL CHIP	5.6K 5% 1/10W (AEP, UK, G, EE)
R357	1-216-055-00	METAL CHIP	1.8K 5% 1/10W (Canadian, AUS, E, EA)
R359	1-216-045-00	METAL CHIP	680 5% 1/10W
R362	1-216-041-00	METAL CHIP	470 5% 1/10W
R363	1-216-045-00	METAL CHIP	680 5% 1/10W
R364	1-216-049-00	METAL CHIP	1K 5% 1/10W
R365	1-216-067-00	METAL CHIP	5.6K 5% 1/10W
R367	1-216-089-00	METAL CHIP	47K 5% 1/10W

When indicating parts by reference number, please include the board name.

PANEL **POWER**

Ref. No.	Part No.	Description	Remarks	Ref. No.	Part No.	Description	Remarks
R368	1-216-089-00	METAL CHIP	47K 5% 1/10W	C514	1-126-053-11	ELECT 220uF	20% 35V
R369	1-216-089-00	METAL CHIP	47K 5% 1/10W	C515	1-124-910-11	ELECT 47uF	20% 50V
R372	1-216-041-00	METAL CHIP	470 5% 1/10W	C516	1-124-478-11	ELECT 100uF	20% 25V
R374	1-216-041-00	METAL CHIP	470 5% 1/10W	C517	1-124-478-11	ELECT 100uF	20% 25V
R375	1-216-081-00	METAL CHIP	22K 5% 1/10W	C518	1-163-037-11	CERAMIC CHIP 0.022uF	10% 25V
R376	1-216-121-00	METAL CHIP	1M 5% 1/10W	C519	1-163-037-11	CERAMIC CHIP 0.022uF	10% 25V
R377	1-216-085-00	METAL CHIP	33K 5% 1/10W	C520	1-126-954-11	ELECT 3300uF	20% 35V
R378	1-216-033-00	METAL CHIP	220 5% 1/10W	C521	1-163-125-00	CERAMIC CHIP 220PF	5% 50V
R379	1-216-025-00	METAL CHIP	100 5% 1/10W	< CONNECTOR >			
R380	1-216-025-00	METAL CHIP	100 5% 1/10W	CN501	1-691-907-11	PIN, CONNECTOR 15P	
R381	1-216-025-00	METAL CHIP	100 5% 1/10W	CN502	1-568-802-11	SOCKET, CONNECTOR 19P	
< SWITCH >				< DIODE >			
S901	1-554-303-21	SWITCH, TACTILE (CD SYNCHRO)		D501	8-719-210-33	DIODE EC10DS2	
S902	1-554-303-21	SWITCH, TACTILE (AMS ◀◀)		D502	8-719-210-33	DIODE EC10DS2	
S903	1-554-303-21	SWITCH, TACTILE (AMS ▶▶)		D503	8-719-210-33	DIODE EC10DS2	
S904	1-554-303-21	SWITCH, TACTILE (REC ● DECK B)		D504	8-719-210-33	DIODE EC10DS2	
S905	1-692-064-11	SWITCH, TACTILE (DECK A)		D505	8-719-210-33	DIODE EC10DS2	
S906	1-692-064-11	SWITCH, TACTILE (DECK B)		D506	8-719-210-33	DIODE EC10DS2	
S907	1-554-303-21	SWITCH, TACTILE (RESET)		D507	8-719-400-18	DIODE MA152WK	
S908	1-554-303-21	SWITCH, TACTILE (DOLBY NR)		D508	8-719-401-71	DIODE MA3068L	
S909	1-554-303-21	SWITCH, TACTILE (DUBBING MODE)		D509	8-719-401-51	DIODE MA3056L	
S910	1-554-303-21	SWITCH, TACTILE (■)		D510	8-719-401-51	DIODE MA3056L	
S911	1-554-303-21	SWITCH, TACTILE (▷)		D511	8-719-210-33	DIODE EC10DS2	
S912	1-554-303-21	SWITCH, TACTILE (◁)		D512	8-719-210-33	DIODE EC10DS2	
S913	1-554-303-21	SWITCH, TACTILE (PAUSE ■■ DECK B)		D513	8-719-402-70	DIODE MA3180	
S914	1-554-303-21	SWITCH, TACTILE (DIRECTION MODE)		D514	8-719-210-33	DIODE EC10DS2	
< CRYSTAL >				D515	8-719-210-33	DIODE EC10DS2	
X351	1-577-101-11	VIBRATOR, CERAMIC (4.19MHz)		D516	8-719-210-33	DIODE EC10DS2	

*	A-2006-713-A	POWER BOARD, COMPLETE(Canadian, AUS, E, EA)					
*	A-2006-716-A	POWER BOARD, COMPLETE(AEP, G, EE)					
*	A-2006-793-A	POWER BOARD, COMPLETE(UK)					

< CAPACITOR >				< FUSE >			
C501	1-124-598-11	ELECT	22uF 20% 25V	△F501	1-532-778-21	FUSE, MICRO 1.6A 125V(Canadian, AUS, E, EA)	
C502	1-124-556-11	ELECT	2200uF 20% 16V	△F502	1-532-778-21	FUSE, MICRO 1.6A 125V(Canadian, AUS, E, EA)	
C503	1-124-556-11	ELECT	2200uF 20% 16V	< IC >			
C504	1-124-910-11	ELECT	47uF 20% 50V	IC501	8-759-996-43	IC RC4558PS	
C505	1-126-163-11	ELECT	4.7uF 20% 50V	< IC LINK >			
C506	1-163-037-11	CERAMIC CHIP	0.022uF 10% 25V	△ICP501	1-532-841-21	LINK, IC (AEP, UK, G, EE)	
C507	1-163-038-00	CERAMIC CHIP	0.1uF 25V	△ICP502	1-532-841-21	LINK, IC (AEP, UK, G, EE)	
C508	1-163-038-00	CERAMIC CHIP	0.1uF 25V	< JUMPER WIRE >			
C509	1-126-022-11	ELECT	47uF 20% 16V	JW501	1-216-296-00	METAL CHIP	0 5% 1/8W
C510	1-126-022-11	ELECT	47uF 20% 16V	JW502	1-216-296-00	METAL CHIP	0 5% 1/8W
C511	1-126-163-11	ELECT	4.7uF 20% 50V	JW503	1-216-296-00	METAL CHIP	0 5% 1/8W
C512	1-126-163-11	ELECT	4.7uF 20% 50V	JW504	1-216-296-00	METAL CHIP	0 5% 1/8W
C513	1-124-478-11	ELECT	100uF 20% 25V				

<p>The components identified by mark Δ or dotted line with mark Δ are critical for safety. Replace only with part number specified.</p>	<p>Les composants identifiés par une marque Δ sont critiques pour la sécurité. Ne les remplacer que par une pièce portant le numéro spécifié.</p>
---	---

When indicating parts by reference number, please include the board name.

POWER

Ref. No.	Part No.	Description	Remarks
< TRANSISTOR >			
Q502	8-729-602-21	TRANSISTOR 2SC4154	
Q503	8-729-209-15	TRANSISTOR 2SD2012	
Q504	8-729-805-44	TRANSISTOR 2SC3397	
Q505	8-729-141-83	TRANSISTOR 2SB1094-LK	
Q506	8-729-209-15	TRANSISTOR 2SD2012	
Q507	8-729-140-04	TRANSISTOR 2SB1116A-L	
Q508	8-729-421-22	TRANSISTOR UN2211	
< RESISTOR >			
R501	1-247-752-11	CARBON 1K 5% 1/2W	
R502	1-216-057-00	METAL CHIP 2.2K 5% 1/10W	
R503	1-216-041-00	METAL CHIP 470 5% 1/10W	
R504	1-216-057-00	METAL CHIP 2.2K 5% 1/10W	
R505	1-216-089-00	METAL CHIP 47K 5% 1/10W	
R506	1-216-065-00	METAL CHIP 4.7K 5% 1/10W	
R507	1-216-069-00	METAL CHIP 6.8K 5% 1/10W	
R508	1-216-053-00	METAL CHIP 1.5K 5% 1/10W	
R509	1-216-053-00	METAL CHIP 1.5K 5% 1/10W	
R510	1-216-069-00	METAL CHIP 6.8K 5% 1/10W	
R511	1-216-073-00	METAL CHIP 10K 5% 1/10W	
R512	1-216-049-00	METAL CHIP 1K 5% 1/10W	
R513	1-216-069-00	METAL CHIP 6.8K 5% 1/10W	
R514	1-216-065-00	METAL CHIP 4.7K 5% 1/10W	
R516	1-216-057-00	METAL CHIP 2.2K 5% 1/10W	
R517	1-216-065-00	METAL CHIP 4.7K 5% 1/10W	

Ref. No.	Part No.	Description	Remarks
MISCELLANEOUS *****			
10	1-690-892-11	WIRE (FLAT TYPE) (12 CORE)	
23	1-590-902-11	WIRE, FLAT TYPE (9 CORE)	
26	1-690-893-11	WIRE (FLAT TYPE) (19 CORE)	
28	1-690-878-11	CORD (WITH CONNECTOR)	
172	1-638-983-11	PC BOARD, MOTOR FLEXIBLE	

- * 177 1-690-419-11 WIRE, LEAD(WITH CONNECTOR)4CORE
- HP901 A-2003-958-B BASE ASSY, HEAD (DECK A)
- HRPE901A-2003-838-A BASE ASSY, HEAD (DECK B)
- M901A X-3359-417-1 CAPSTAN MOTOR ASSY (DECK A)
- M901B X-3359-417-1 CAPSTAN MOTOR ASSY (DECK B)
- M902A X-3363-501-1 REEL MOTOR ASSY (DECK A)
- M902B X-3363-501-1 REEL MOTOR ASSY (DECK B)

HARDWARE LIST

- #1 7-621-773-93 SCREW (PANEL 2.6 TP2)
- #2 7-621-255-15 SCREW +PTT 2X3 (S)
- #3 7-685-646-79 SCREW +BVTP 3X8 TYPE2 N-S
- #4 7-682-547-04 SCREW +BVTT 3X6 (S)
- #6 7-621-775-00 SCREW +B 2.6X3
- #7 7-627-556-08 SCREW +P 2.6X2.8

When indicating parts by reference number, please include the board name.

TC-H1700

SONY® SERVICE MANUAL

AEP Model
UK Model
E Model
Australian Model

SUPPLEMENT-1

File this supplement with the service manual.

Additional of Italian model.

- For Italian model, see the description on Germany model in the 9-957-006-11 service manual.