

# TC-K470/RX470

## SERVICE MANUAL

US Model  
Canadian Model  
TC-RX470  
AEP Model  
UK Model  
Germany Model  
TC-K470



Photo: TC-RX470

\* Dolby noise reduction and HX Pro headroom extension manufactured under license from Dolby Laboratories Licensing Corporation. HX Pro originated by Bang & Olufsen.

"DOLBY", the double-D symbol  $\square\square$  and "HX PRO" are trademarks of Dolby Laboratories Licensing Corporation.

### SPECIFICATIONS

Recording system	4-track 2-channel stereo
Fast-winding time	Approx. 90 sec. (with Sony C-60 cassette)
Bias	AC bias
Heads	Erasing head $\times$ 1 (ferrite head) Playback/Recording head $\times$ 1 (SD head)
Motors	Capstan motor $\times$ 1 (DC servo motor) Reel motor $\times$ 1 (DC motor) ASIST (mechanical drive) motor $\times$ 1 (DC motor)

Signal-to-noise ratio (NAB (TC-RX470) , at peak level)  
TC-RX470

Cassette	Dolby NR switch		
	OFF	B-type ON	C-type ON
Type IV (Sony METAL-SLT)	58 dB	66 dB	73 dB
Type II (Sony UX-S)	57 dB	65 dB	72 dB
Type I (Sony HF-S)	55 dB	63 dB	70 dB

#### TC-K470

Cassette	Dolby NR switch		
	OFF	B-type ON	C-type ON
Type IV (Sony METAL-S)	59 dB	67 dB	74 dB
Type II (Sony UX-S)	58 dB	66 dB	73 dB
Type I (Sony HF-S)	56 dB	64 dB	71 dB

Total harmonic distortion

1.0% (with Sony METAL-SLT cassette)

Frequency response (DOLBY NR OFF)  
TC-RX470

Type IV cassette (Sony METAL-SLT)	30 - 16,000 Hz ( $\pm$ 3 dB) 30 - 14,000 Hz [0 VU (- 4dB) recording]
Type II cassette (Sony UX-S)	30 - 15,000 Hz ( $\pm$ 3 dB)
Type I cassette (Sony HF-S)	30 - 14,000 Hz ( $\pm$ 3 dB)

Model Name Using Similar Mechanism	TC-WR870
Tape Transport Mechanism Type	TC-RX470: TCM-200R7 TC-K470 TCM-200V6

#### TC-K470

Type IV cassette (Sony METAL-S)	30 - 18,000 Hz ( $\pm$ 3 dB, IEC) 30 - 15,000 Hz [0 VU (- 4dB) recording]
Type II cassette (Sony UX-S)	30 - 17,000 Hz ( $\pm$ 3 dB, IEC)
Type I cassette (Sony HF-S)	30 - 15,000 Hz ( $\pm$ 3 dB, IEC)

Wow and flutter  
 $\pm$  0.09% W.Peak (IEC)  
0.06% WRMS (NAB)  
 $\pm$  0.16% W.Peak (DIN)

#### Inputs

Line inputs (phono jacks)	Sensitivity	77.5 mV
	Input impedance	47 k ohms
Microphone inputs (phone jacks) TC-RX470	Sensitivity (For a low-impedance microphone)	0.25 mV

#### Outputs

Line outputs (phono jacks)	Rated output level	0.32 V at a load impedance of 47 k ohms
	Load impedance	Over 10 k ohms
Headphones (stereo phone jack)	Output level	0.3 mW (TC-RX470) or 0 - 1.25 mW (TC-K470) at a load impedance of 32 ohms

- Continued on next page -

STEREO CASSETTE DECK  
**SONY**<sup>®</sup>

**General**

**Power requirements**

US, Canadian models:  
120 V AC, 60 Hz  
AEP, Germany models:  
220 – 230 V AC, (or 240 V AC  
adjustable by Sony personnel),  
50/60 Hz  
UK model:  
240 V AC (or 220 V AC  
adjustable by Sony personnel),  
50/60 Hz

**Power consumption** 17 W

**Dimensions**

Approx. 430 × 123 × 300 mm  
(w/h/d)  
(17 × 4<sup>7</sup>/<sub>8</sub> × 11<sup>7</sup>/<sub>8</sub> inches)  
including projecting parts and  
controls

**Weight**

TC-RX470: Approx. 4.6 kg  
(10 lbs. 3 oz.)  
TC-K470: Approx. 4.5 kg  
(10 lbs. 3 oz.)

**Supplied accessory**

Audio connecting cords (2)

Design and specifications subject to change without notice.

**MODEL IDENTIFICATION**

– Specification Labels –

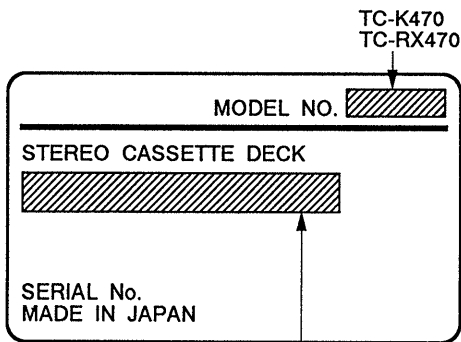

US, Canadian models: AC 120 V 60 Hz 17 W  
Germany, AEP models: AC 220 – 230 V ~50/60 Hz  
UK model: AC 240 V ~50/60 Hz

**TABLE OF CONTENTS**

<u>Section</u>	<u>Title</u>	<u>Page</u>
Specifications	.....	1
Safety Check-out	.....	2
<b>1. GENERAL</b>		
	Identification of Front Panel Parts .....	3
<b>2. DISASSEMBLY</b>	.....	4
<b>3. ADJUSTMENTS</b>		
3-1.	Mechanical Adjustment .....	6
3-2.	Electrical Adjustments .....	6
<b>4. DIAGRAMS</b>		
4-1.	Printed Wiring Board .....	10
4-2.	Schematic Diagram .....	13
<b>5. EXPLODED VIEWS</b>	.....	17
<b>6. ELECTRICAL PARTS LIST</b>	.....	21

**SAFETY-RELATED COMPONENT WARNING!!**

COMPONENTS IDENTIFIED BY MARK OR DOTTED LINE WITH MARK ON THE SCHEMATIC DIAGRAMS AND IN THE PARTS LIST ARE CRITICAL TO SAFE OPERATION. REPLACE THESE COMPONENTS WITH SONY PARTS WHOSE PART NUMBERS APPEAR AS SHOWN IN THIS MANUAL OR IN SUPPLEMENTS PUBLISHED BY SONY.

**ATTENTION AU COMPOSANT AYANT RAPPORT À LA SÉCURITÉ!**

LES COMPOSANTS IDENTIFIÉS PAR UNE MARQUE SUR LES DIAGRAMMES SCHÉMATIQUES ET LA LISTE DES PIÈCES SONT CRITIQUES POUR LA SÉCURITÉ DE FONCTIONNEMENT. NE REMPLACER CES COMPOSANTS QUE PAR DES PIÈCES SONY DONT LES NUMÉROS SONT DONNÉS DANS CE MANUEL OU DANS LES SUPPLÉMENTS PUBLIÉS PAR SONY.

## SAFETY CHECK-OUT

After correcting the original service problem, perform the following safety check before releasing the set to the customer:

Check the antenna terminals, metal trim, "metallized" knobs, screws, and all other exposed metal parts for AC leakage. Check leakage as described below.

### LEAKAGE TEST

The AC leakage from any exposed metal part to earth ground and from all exposed metal parts to any exposed metal part having a return to chassis, must not exceed 0.5 mA (500 microamperes). Leakage current can be measured by any one of three methods.

1. A commercial leakage tester, such as the Simpson 229 or RCA WT-540A. Follow the manufacturers' instructions to use these instruments.
2. A battery-operated AC milliammeter. The Data Precision 245 digital multimeter is suitable for this job.
3. Measuring the voltage drop across a resistor by means of a VOM or battery-operated AC voltmeter. The "limit" indication is 0.75 V, so analog meters must have an accurate low-voltage scale. The Simpson 250 and Sanwa SH-63Trd are examples of a passive VOM that is suitable. Nearly all battery operated digital multimeters that have a 2 V AC range are suitable. (See Fig. A)

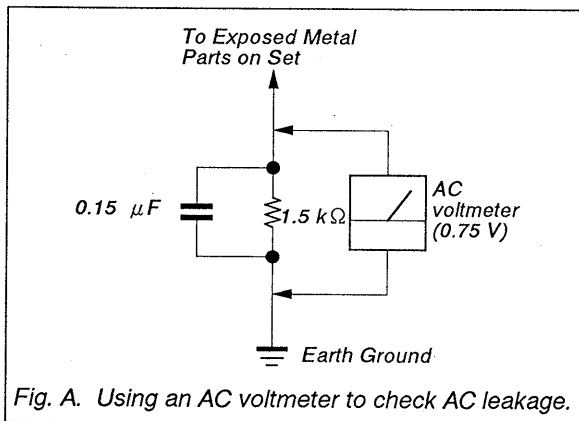
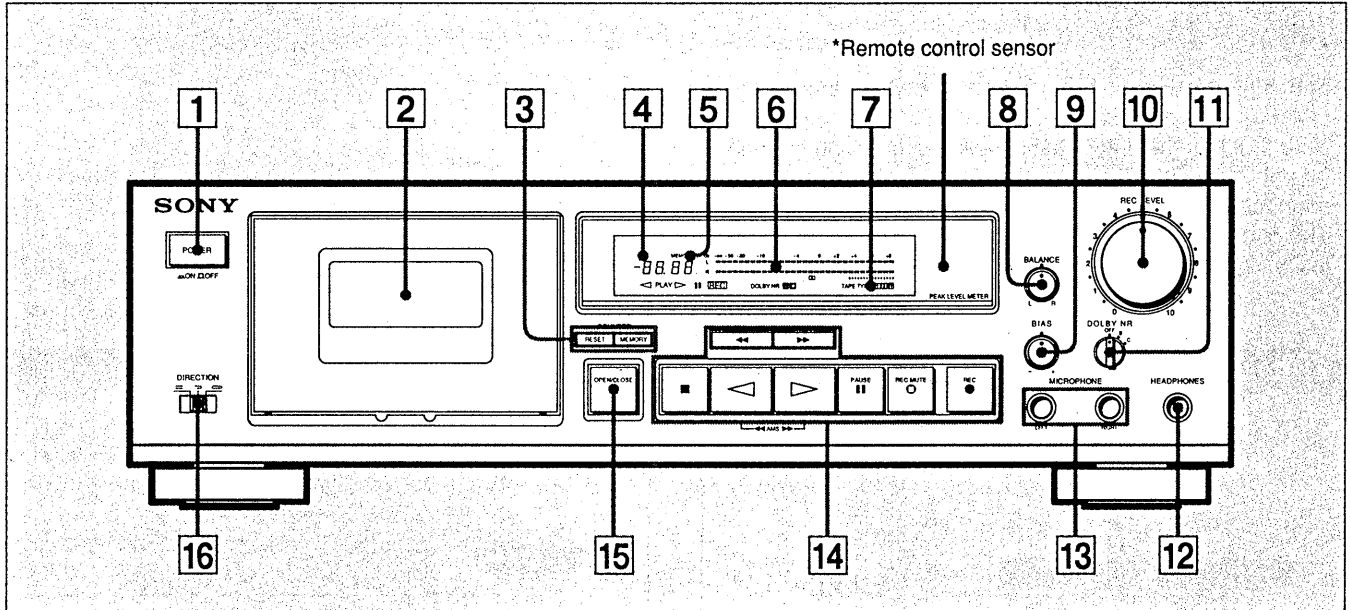

Fig. A. Using an AC voltmeter to check AC leakage.

## Identification of Front Panel Parts

TC-RX470



For details, refer to the page number indicated in ●.

- |   |  |
|---|--|
| <p>1 POWER switch</p> <p>2 Cassette holder</p> <p>3 Counter buttons<br/>RESET button ⑨<br/>MEMORY button ⑧ ⑨</p> <p>4 DIGITAL LINEAR COUNTER ⑨</p> <p>5 MEMORY indicator ⑧ ⑨</p> <p>6 PEAK LEVEL METER ⑪</p> <p>7 TAPE TYPE indicators</p> <p>8 BALANCE control ⑩</p> <p>9 BIAS control ⑪</p> <p>10 REC (recording) LEVEL control ⑩ ⑪</p> <p>11 DOLBY NR (noise reduction switch) ⑦ ⑩</p> | <p>12 HEADPHONES jack (stereo phone jack)</p> <p>13 MICROPHONE jacks (phone jacks) (left and right) ⑩</p> <p>14 Tape operation buttons<br/>◀◀ (leftward fast winding) button<br/>▶▶ (rightward fast winding) button<br/>■ (stop) button<br/>◀ (reverse play) button<br/>▶ (forward play) button<br/>   PAUSE button<br/>○ REC MUTE (record muting) button ⑫<br/>● REC (recording) button</p> <p>15 ▲ OPEN/CLOSE button</p> <p>16 DIRECTION mode switch ⑦ ⑩</p> |
|---|--|

\*Remote control sensor

You can remotely control this cassette deck with:  
— A remote commander that came with a Sony amplifier or receiver if it has the  mark and cassette deck control capability.

TC-K470

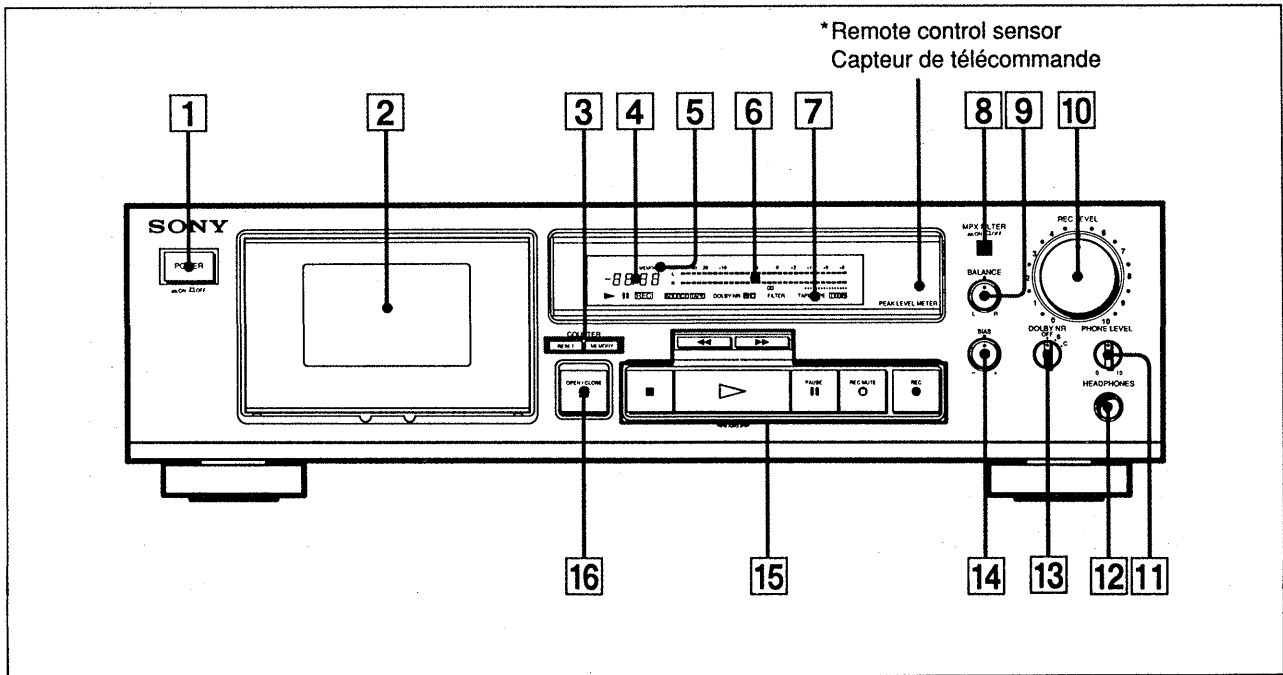



For details, refer to the page number indicated in ●.

- |   |   |
|---|---|
| <p><b>1</b> POWER switch</p> <p><b>2</b> Cassette holder</p> <p><b>3</b> Counter buttons<br/>RESET button ●<br/>MEMORY button ● ●</p> <p><b>4</b> LINEAR COUNTER ●</p> <p><b>5</b> MEMORY indicator ● ●</p> <p><b>6</b> PEAK LEVEL METER ●</p> <p><b>7</b> TAPE TYPE indicator ●</p> <p><b>8</b> MPX FILTER button ●</p> <p><b>9</b> BALANCE control</p> <p><b>10</b> REC (recording) LEVEL control ●</p> | <p><b>11</b> PHONE (headphones) LEVEL control</p> <p><b>12</b> HEADPHONES jack (stereo phone jack) ●</p> <p><b>13</b> DOLBY NR (noise reduction) switch ● ●</p> <p><b>14</b> BIAS control ●</p> <p><b>15</b> Tape operation buttons<br/>◀◀ (rewind) button<br/>▶▶ (fast-forward) button<br/>■ (stop) button<br/>▶ (play) button<br/>   PAUSE button<br/>○ REC MUTE (record muting) button ●<br/>● REC (recording) button</p> <p><b>16</b> ▲ OPEN/CLOSE button</p> |
|---|---|

**\*Remote control sensor**

You can remotely control this cassette deck with:

- A remote commander that came with a Sony amplifier or receiver if it has the  mark and cassette deck control capability.
- An optional Sony remote commander with the  mark and cassette deck control capability.

## SECTION 2 DISASSEMBLY

**Note:** Follow the disassembly procedure in the numerical order given.

### CASSETTE HOLDER (Illustration: TC-RX470)

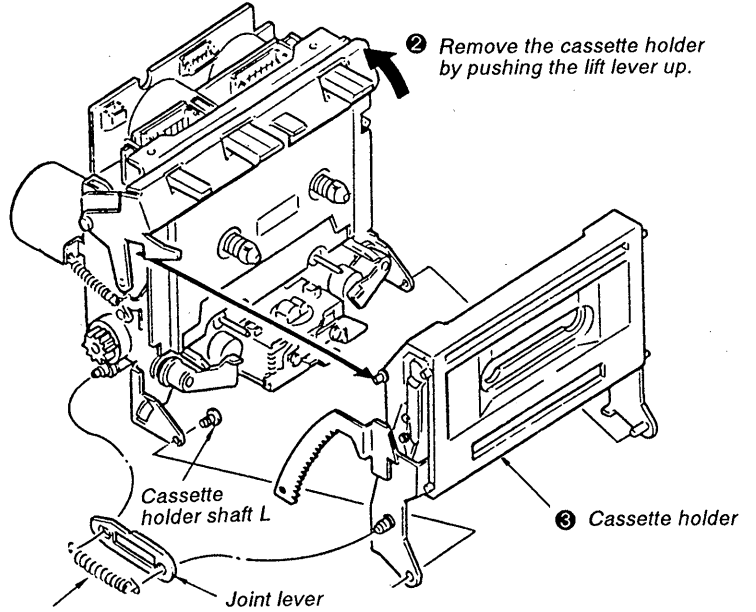

### ORNAMENTAL PLATE (Illustration: TC-RX470) ① Tension spring

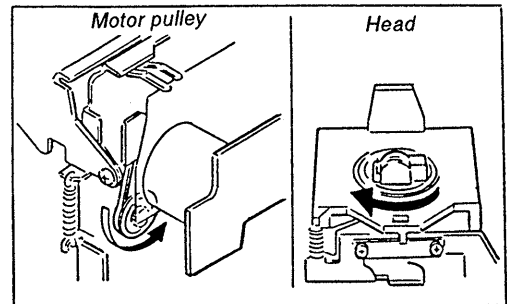
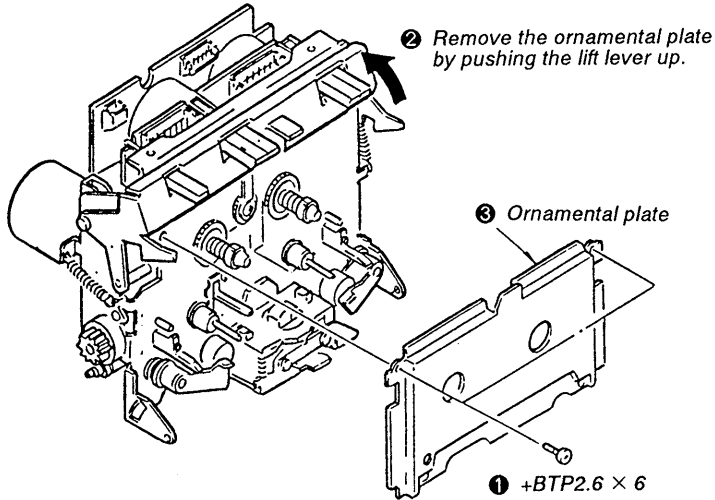

⑤ Turn the motor pulley by a finger and confirm that the head has turned in the direction of arrow.

### PINCH LEVER (TC-K470)

### PINCH LEVER, HEAD (TC-RX470)

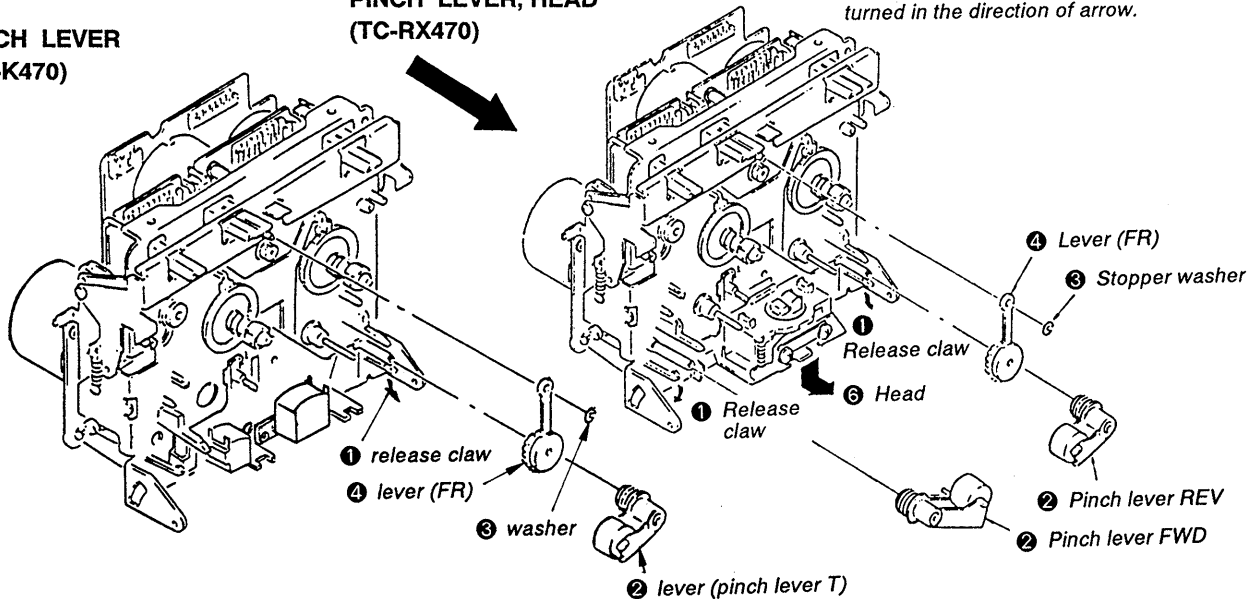

**CAPSTAN PLATE, FLYWHEEL**

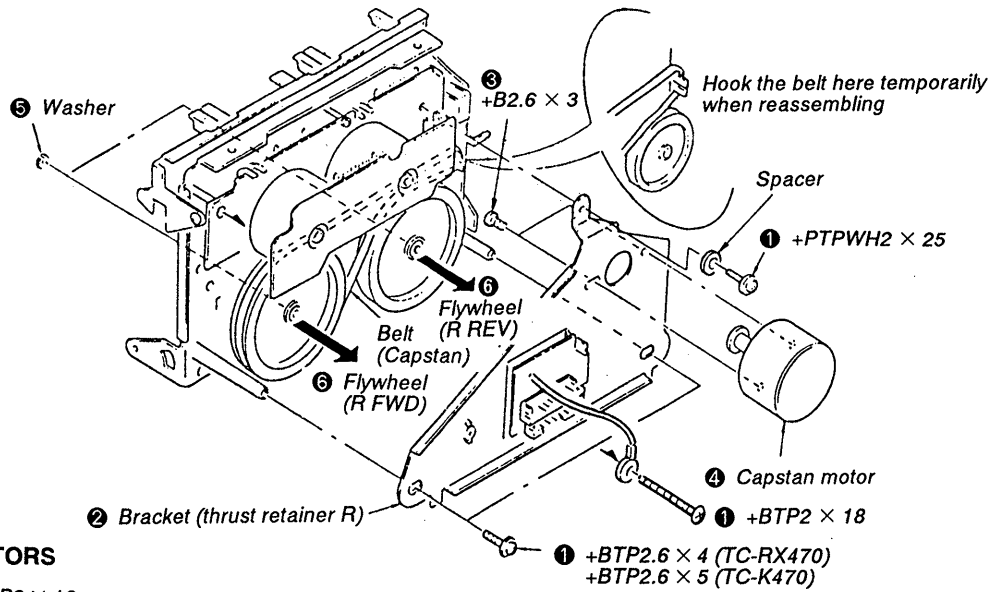

**REEL AND ASSIST MOTORS**

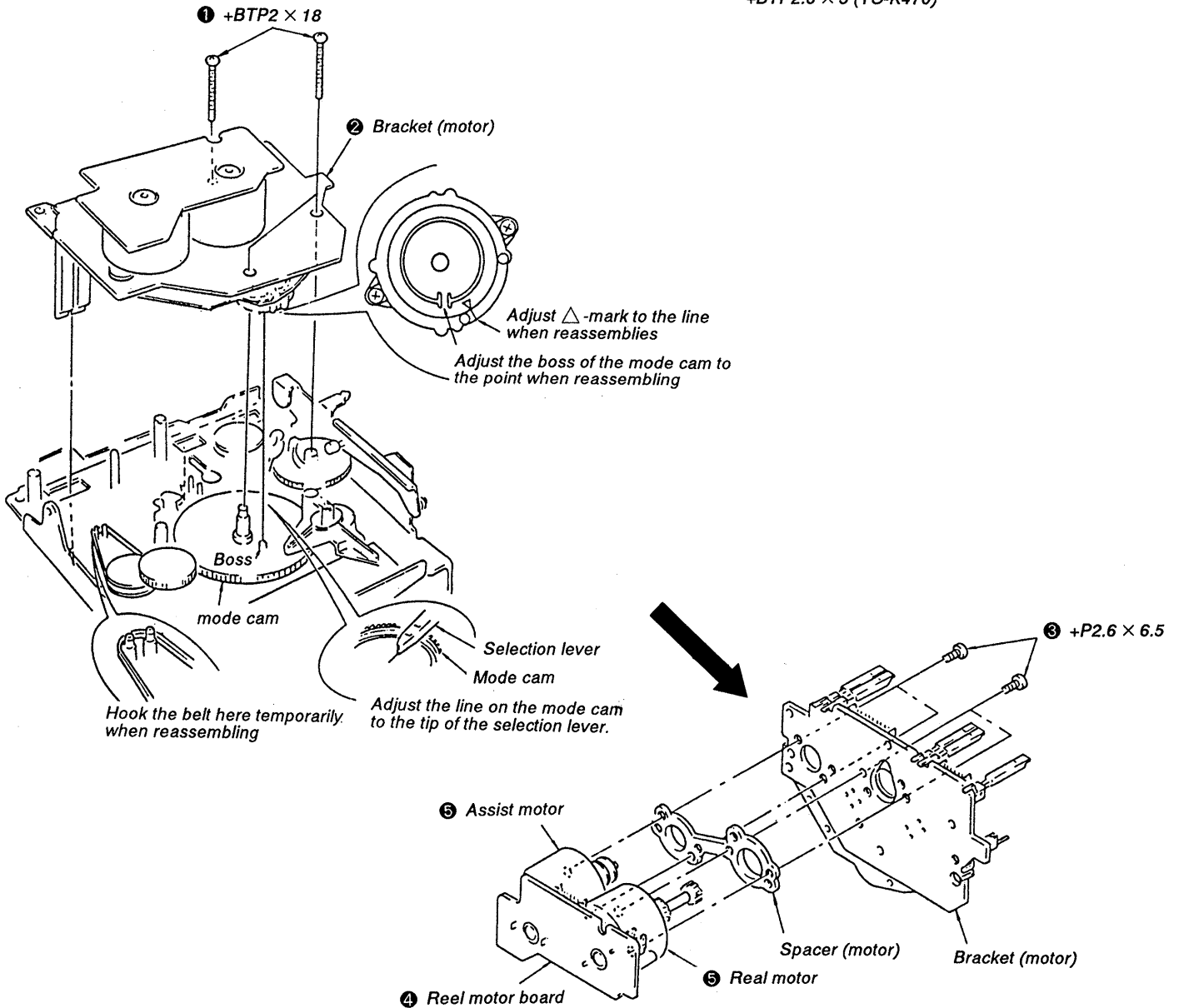

## SECTION 3 ADJUSTMENTS

### 3-1. MECHANICAL ADJUSTMENT

#### PRECAUTION

1. Clean the following parts with a denatured-alcohol-moistened swab:
 

record/playback head	pinch rollers
erase head	rubber belts
capstans	idlers
2. Demagnetize the record/playback head with a head demagnetizer.
3. Do not use a magnetized screwdriver for the adjustments.
4. After the adjustments, apply suitable locking compound to the parts adjusted.
5. The adjustments should be performed in the rated power supply voltage unless otherwise noted.

#### Torque Measurement

Torque	Torque Meter	Meter reading
FWD	CQ-102C	30 – 60 g•cm (0.42 – 0.83 oz•inch)
FWD back tension		1 – 5 g•cm (0.014 – 0.063 oz•inch)
REV (TC-RX470)	CQ-102RC	30 – 60 g•cm (0.42 – 0.83 oz•inch)
REV back tension (TC-RX470)		1 – 5 g•cm (0.014 – 0.063 oz•inch)
FF/REW	CQ-201B	65 – 90 g•cm (0.90 – 1.25 oz•inch)

### 3-2. ELECTORICAL ADJUSTMENTS

#### PRECAUTION

**Note:** The adjustment should be performed in the order given in the service manual. As a rule, adjustments about playback should be performed before those about recording.  
The adjustments should be performed for both L-ch and R-ch.

Switches and controls should be set as follows unless otherwise specified.

DOLBY NR switch ..... OFF  
 DIRECTION MODE (TC-RX470) ..... ⇄  
 MPX switch (TC-K470) ..... OFF

**Standard Record:**  
 Deliver the standard input signal level to the input jack and set the REC LEVEL control to obtain the standard output signal level.

#### – Record Mode –

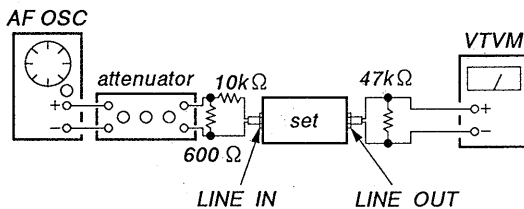

0 dB=775m V

#### Standard Input Level

input terminal	LINE IN
source impedance	10kΩ
input level	0.25V ( – 10dB)

#### Standard Output Level

output terminal	LINE OUT
load impedance	47kΩ
output level	0.32V ( – 7.7dB)

#### Test Tape

Type	Signal	Used for
P-4-A100	10 kHz, – 10 dB	Azimuth adjustment
P-4-L300	315 Hz, 0 dB	PB level adjustment
WS-48B	3 kHz, 0 dB	Tape speed adjustment

The set will get into TEST MODE by shorting the pins of TP801 (TEST) on Main board before turning the power on, and TEST MODE functions as follows:

#### Record/Playback Head Azimuth Adjustment

##### Procedure:

1. Mode: FWD playback

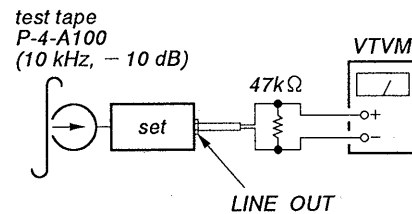

2. Turn the adjustment screw for the maximum output levels. If these levels do not match, turn the adjustment screw until both of output levels match together within 1 dB.

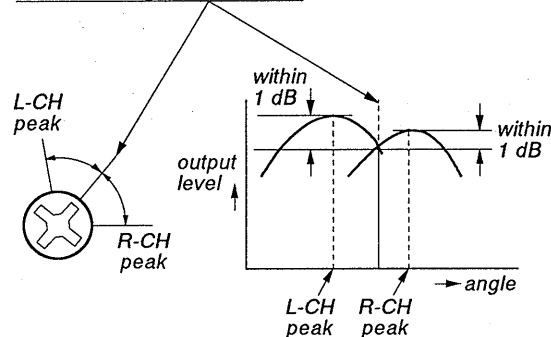



3. Phase Check  
Mode: playback

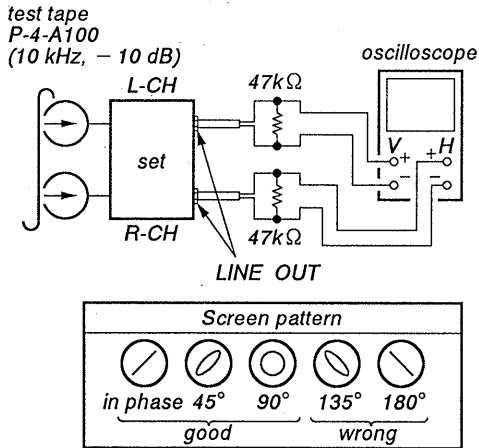

4. Set in the REV mode and repeat the step 1 to 3. (TC-RX470)  
5. After the adjustment, lock the screws with locking compound.

**Adjustment Location:** Record/Playback head

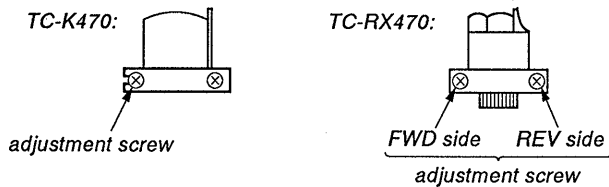

### Tape Speed Adjustment

**FWD** **REV (TC-RX470)**

#### Procedure:

Mode: playback

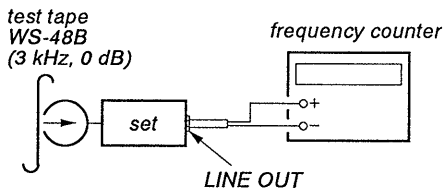

#### Specification:

Speed checker	Digital frequency counter
± 0.5%	2,985 - 3,015 Hz

Frequency difference between the beginning and the end of the tape should be within 0.5% (15 Hz).

#### Adjustment Location:

Adjustment the adjustable resistor of built in motor (adjustment by the insert to driver speed in fastest that turn the clockwise).

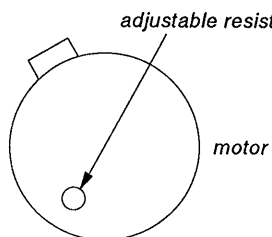

### Playback Level Adjustments

#### Procedure:

Mode: playback

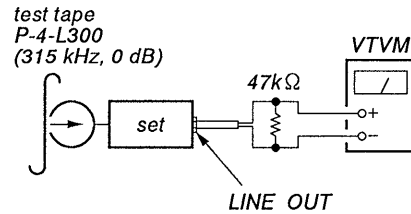

Adjust with RV101 (L-ch), RV201 (R-ch) so that the reading on VTVM meets the adjustment limits below.

#### Adjustment Limits:

LINE OUT level:  $-7.7 \pm 0.5\text{dB}$  (0.30 - 0.34 V)

Level difference between channels: less than 0.5 dB

Check that the LINE OUT level does not change even if Playback and Stop operation is repeated several times.

**Adjustment Location:** MAIN board

### Bias Current Adjustment

#### Procedure:

1. Set RV103 and RV203 to mechanical center and turn the set recording mode.
2. Connect digital voltmeter as shown by the following table.
3. Adjust the following transformers for the minimum readings on the digital voltmeter.

DECK	Mesurement Point	Adjustment	Value
L	① and ②, TP501	T101	Less than 160 mV
R	② and ③, TP501	T201	

**Adjustment Location:** MAIN board

### Record Bias Adjustment

#### Setting:

REC LEVEL control: standard Record (See page 8.)

test pin TP801: short

#### Procedure:

1. Mode: record

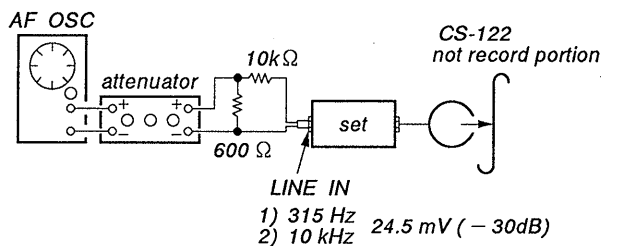

2. Mode: playback

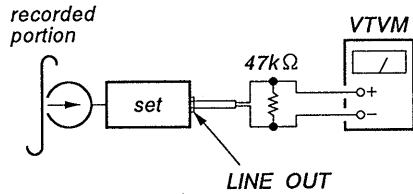

Playback the signal recorded in step 1.  
 Confirm that the 10 kHz playback output is  $0 \pm 0.5$  dB relative to the 315 Hz output. If necessary, adjust RV103 (L-ch) and RV203 (R-ch) and repeat the steps given above.

**Adjustment Location:** MAIN board

### Record Level Adjustment

**Setting:**

REC LEVEL control: Standard Record (See page 8.)  
 test pin TP801: short

**Procedure:**

1. Mode: Record

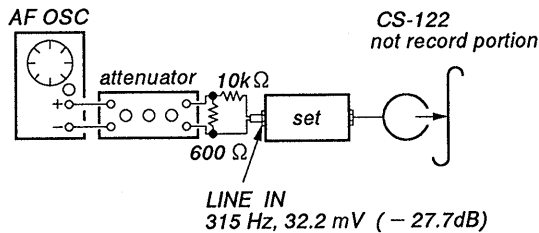

2. Mode: Playback

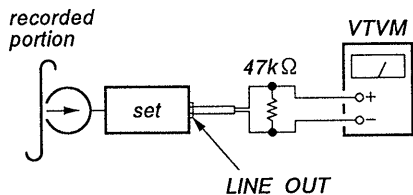

3. Playback the signal recorded in step 1.  
 Confirm that the signal level is within the adjustment limits below.  
 IF necessary, adjust RV141 (L-ch) and RV241 (R-ch) and repeat the step 1 to 2.

**Adjustment Limits:**  $-27.7$  dB  $\pm$  0.5 dB (30.4 – 34.2 mV)

**Adjustment Location:** MAIN board (component side)

### Quick Reverse Sensitivity Adjustment (TC-RX470)

**Conditions :**

DIRECTION MODE switch:  $\rightleftarrows$

**Adjustment procedure :**



1. Connect the digital voltmeter to test point TP802.
2. Load C-120 tape cassette and playback the leading portion in FWD mode.
3. Adjust the RV871 for  $4.5 \pm 0.5$  V reading on the digital voltmeter.
4. Playback C-120 tape cassette in FWS mode again.
5. Confirm that the reading on the digital voltmeter is "L" level at the magnetic portion of the tape.
6. Confirm that the tape stop around the tape end (border of the leading and the magnetic portions).

**Adjustment Location:** MAIN board

### [Adjustment Parts Location Diagram]

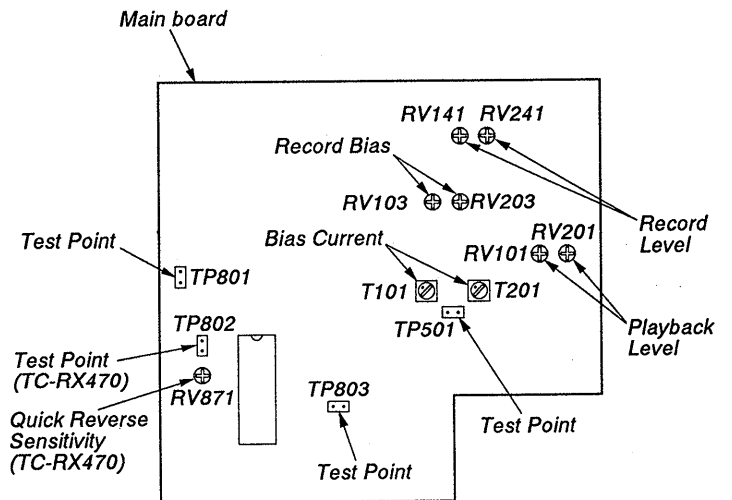

# SECTION 4 DIAGRAMS

## 4-1. BLOCK DIAGRAM

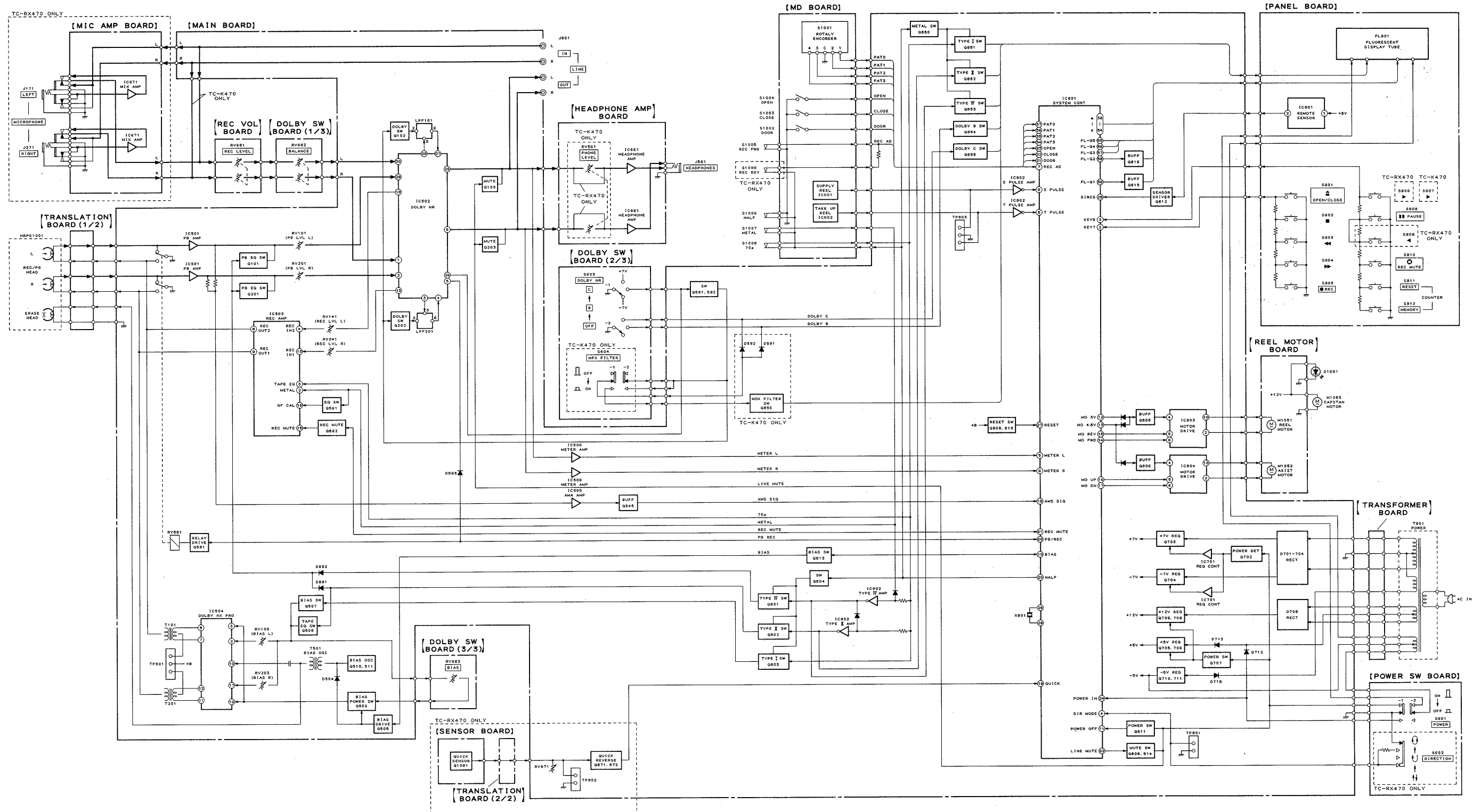

● Semiconductor Lead Layouts

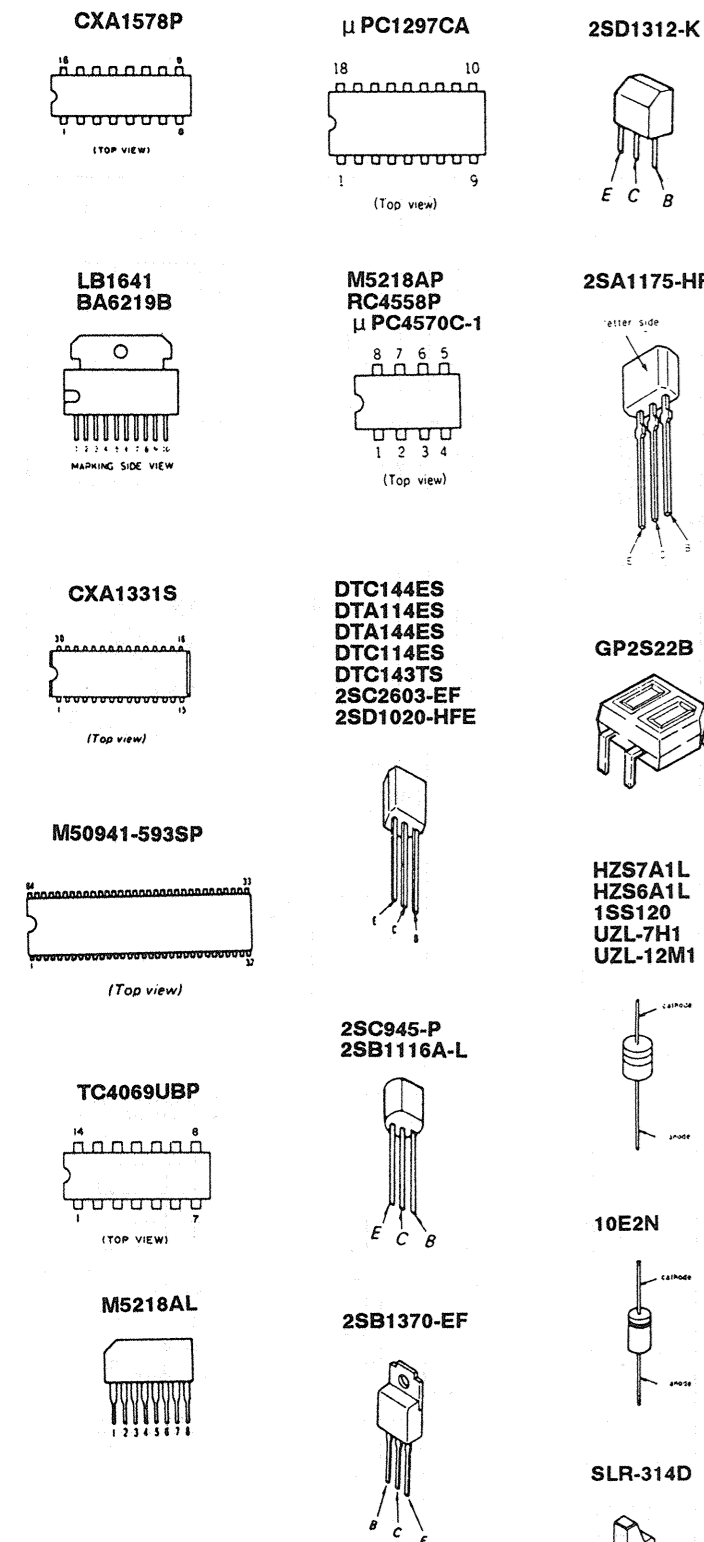

● Semiconductor Location

Ref. No.	Location	Ref. No.	Location
D101	B-13	IC804	E-16
D102	F-15	IC901	H-8
D201	B-14	IC1001	I-21
D202	F-15	IC1002	I-22
D504	E-14		
D545	E-10	Q101	F-11
D581	H-10	Q102	D-11
D582	H-13	Q103	C-13
D591	I-13	Q201	F-10
D592	I-13	Q202	D-9
D701	B-18	Q203	C-13
D702	B-18	Q505	E-14
D703	C-18	Q506	E-14
D704	C-18	Q507	E-12
D705	C-16	Q508	E-12
D706	B-16	Q510	G-12
D708	D-18	Q511	G-12
D709	D-18	Q545	E-18
D710	C-18	Q581	D-13
D711	C-18	Q582	D-13
D712	D-18	Q581	J-13
D713	D-18	Q591	I-13
D714	C-16	Q592	I-13
D715	C-16	Q702	C-16
D716	B-18	Q703	A-16
D717	B-18	Q704	A-16
D718	D-17	Q705	C-16
D719	D-15	Q706	C-16
D720	D-15	Q707	D-16
D801	G-14	Q708	A-17
D802	G-14	Q709	B-17
D803	E-18	Q710	D-16
D804	E-18	Q711	D-15
D805	E-18	Q801	G-15
D806	G-16	Q802	G-15
D810	F-15	Q803	G-15
D871	G-19	Q804	G-15
D891	H-13	Q805	E-17
D892	H-14	Q806	E-17
D893	F-14	Q808	G-16
D901	H-5	Q809	H-18
D902	H-5	Q810	I-18
D903	H-6	Q811	F-17
D904	H-6	Q812	H-18
D1001	J-26	Q813	E-14
D1091	G-22	Q814	F-16
		Q815	I-16
		Q816	I-16
IC501	G-10	Q816	I-16
IC502	C-10	Q850	I-16
IC503	C-12	Q851	I-15
IC504	E-12	Q852	I-15
IC505	E-15	Q853	I-15
IC506	B-13	Q854	I-15
IC661	B-2	Q855	I-14
IC671	B-8	Q856	I-14
IC701	B-15	Q871	G-18
IC801	G-17	Q872	G-18
IC802	H-14	Q1091	G-22
IC803	E-17		

● Circuit Boards Location

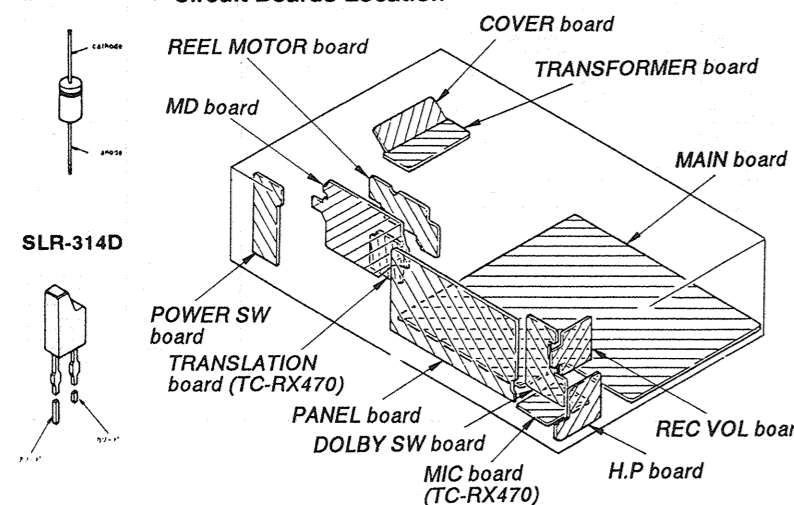

4-2. PRINTED WIRING BOARD

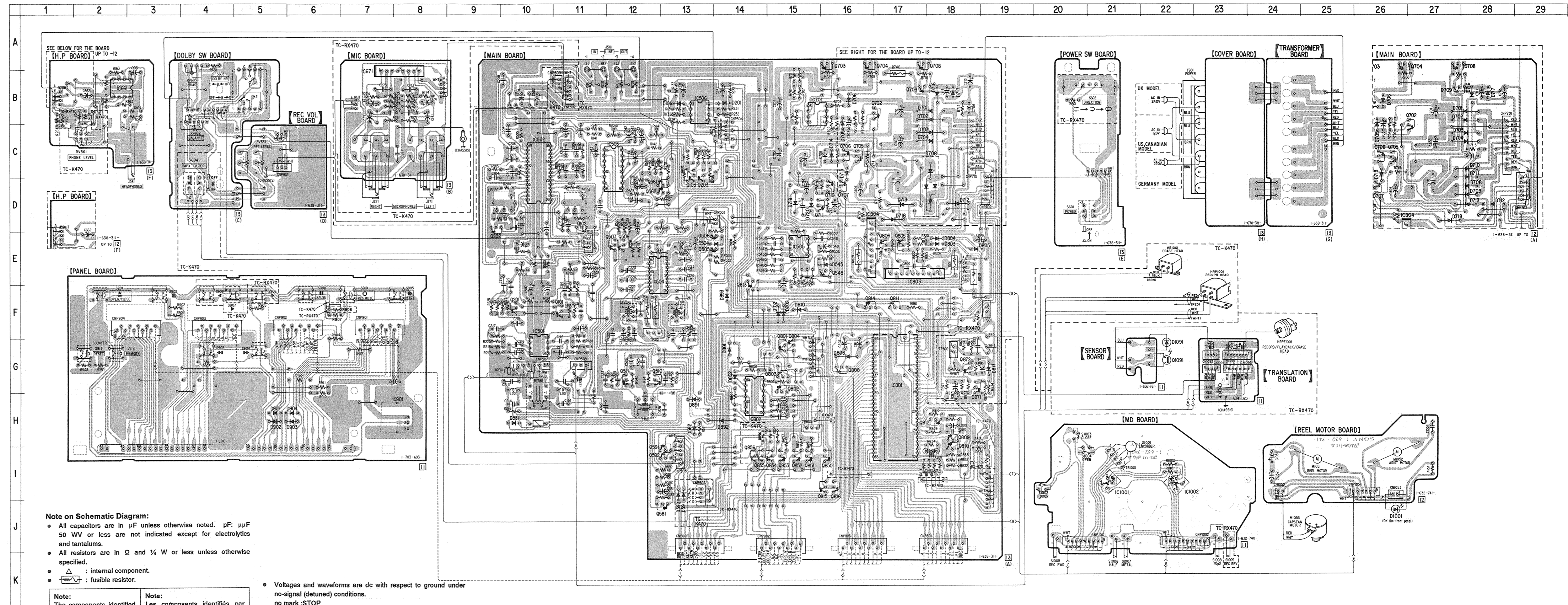

Note on Schematic Diagram:

- All capacitors are in  $\mu\text{F}$  unless otherwise noted. pF:  $\mu\text{F}$  50 WV or less are not indicated except for electrolytics and tantalums.
- All resistors are in  $\Omega$  and  $\frac{1}{4} \text{W}$  or less unless otherwise specified.
- $\Delta$ : internal component.
- $\text{---}/\text{---}$ : fusible resistor.

**Note:**  
The components identified by mark  $\Delta$  or dotted line with mark  $\Delta$  are critical for safety. Replace only with part number specified.

**Note:**  
Les composants identifiés par une marque  $\Delta$  sont critiques pour la sécurité. Ne les remplacer que par une pièce portant le numéro spécifié.

- Voltages and waveforms are dc with respect to ground under no-signal (detuned) conditions. no mark :STOP ( ) :REC ( ( ) ) :PB
- Voltages are taken with a VOM (Input Impedance 10 M $\Omega$ /V). Voltage variations may be noted due to normal production tolerances.
- Signal path.  $\text{---}$  : PB  $\text{---}$  : REC

- $\text{---}$  : B + Line.
- $\text{---}$  : B - Line.
- $\text{---}$  : adjustment for repair.

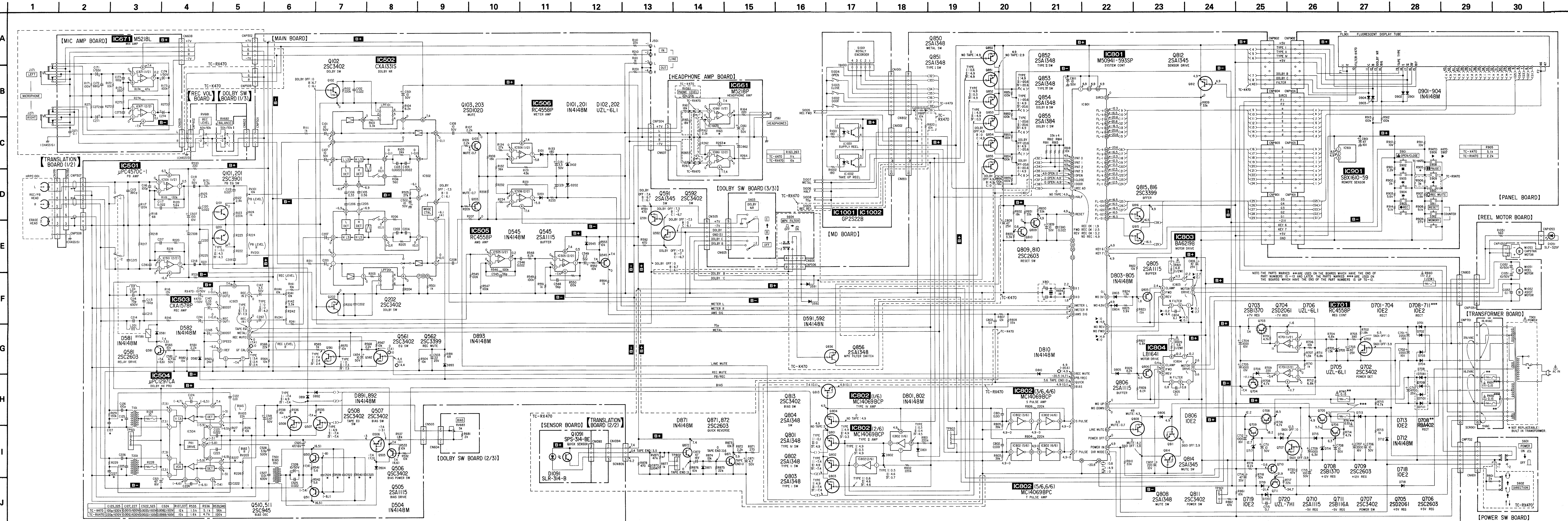

## SECTION 5 EXPLODED VIEWS

**NOTE:**

- -XX and -X mean standardized parts, so they may have some difference from the original one.

- Color Indication of Appearance Parts  
Example:  
KNOB, BALANCE (WHITE) . . . (RED)

↑ Parts Color    ↑ Cabinet's Color

- Items marked "\*" are not stocked since they are seldom required for routine service. Some delay should be anticipated when ordering these items.

- The mechanical parts with no reference number in the exploded views are not supplied.

- Hardware (# mark) list is given in the last of this parts list.

The components identified by mark  $\triangle$  or dotted line with mark  $\triangle$  are critical for safety. Replace only with part number specified.

Les composants identifiés par une marque  $\triangle$  sont critiques pour la sécurité. Ne les remplacer que par une pièce portant le numéro spécifié.

**(1) CABINET SECTION**

▲G: TRANSFORMER BOARD  
▲H: COVER BOARD

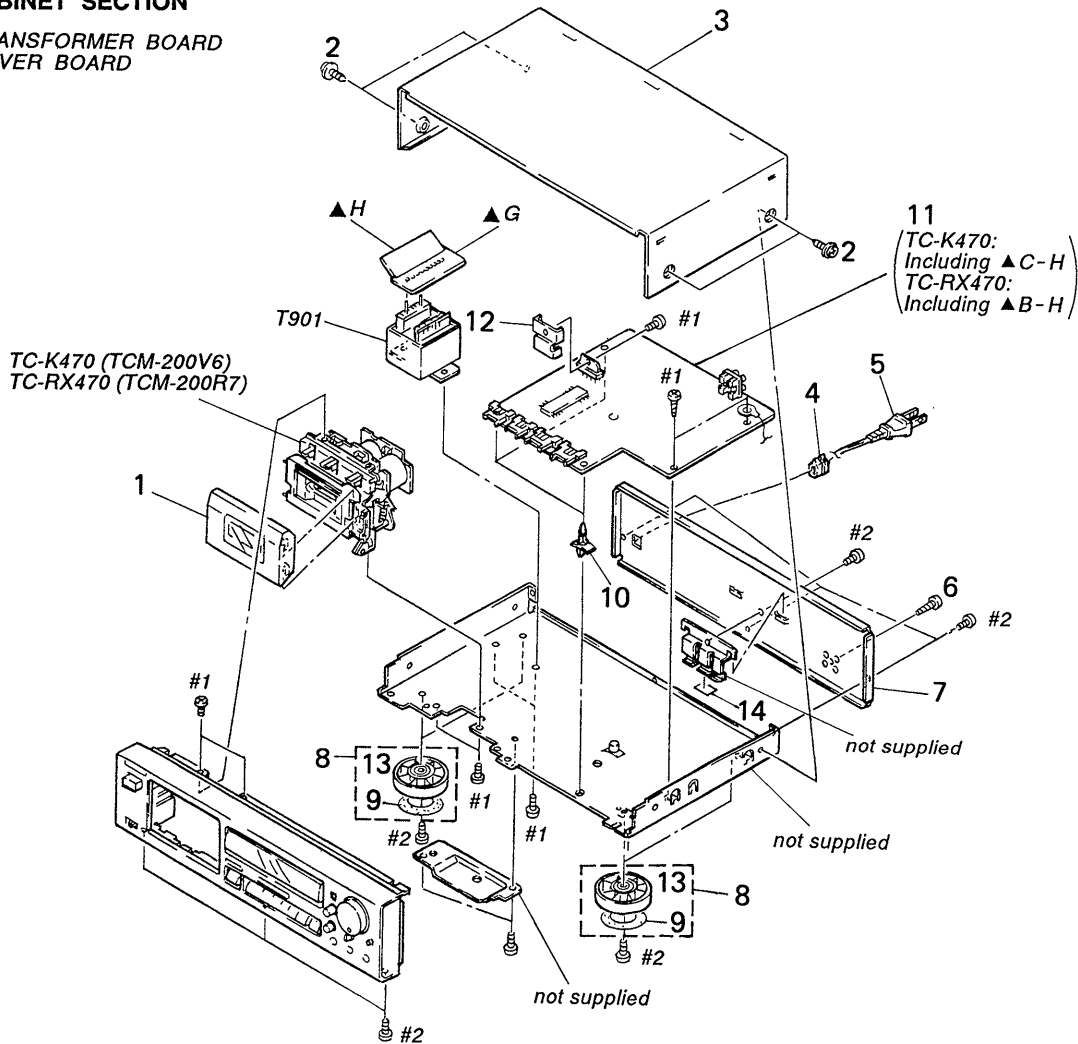

Ref. No.	Part No.	Description	Remark	Ref. No.	Part No.	Description	Remark
1	X-3363-009-1	LID (A) ASSY, CASSETTE (RX470)		8	X-3304-938-2	FOOT ASSY (K470)	
1	X-3363-219-1	LID (A) ASSY, CASSETTE (K470)		8	X-4885-950-1	FOOT ASSY (RX470)	
2	3-704-366-01	SCREW (CASE) (M3X8)		9	4-923-836-11	CUSHION	
3	3-332-578-61	CASE		10	* 3-346-265-11	HOLDER, PC BOARD	
4	* 3-703-244-00	BUSHING (S) (2104), CORD		11	* A-2006-466-A	MAIN BOARD, COMPLETE (RX470)	
4	* 3-703-571-11	BUSHING (S) (4516), CORD		11	* A-2006-532-A	MAIN BOARD, COMPLETE (K470)	
5	$\triangle$ 1-551-506-XX	CORD, POWER (RX470)		12	* 3-356-925-01	HEAT SINK	
5	$\triangle$ 1-555-795-00	CORD, POWER, EURO PLUG (K470:AEP, Germany)		13	4-943-148-01	FOOT (F58175SHW) (BLACK) (RX470)	
5	$\triangle$ 1-556-035-00	CORD, POWER (K470:UK)		13	4-943-148-12	FOOT (F58175SHW) (SILVER) (K470)	
6	7-621-849-00	SCREW (BV/RING)		14	9-911-843-XX	CUSHION, RUBBER	
7	* 3-366-793-01	PANEL, BACK (RX470)		T901	$\triangle$ 1-450-100-11	TRANSFORMER, POWER (RX470)	
7	* 3-367-973-11	PANEL, BACK (K470:AEP, Germany)		T901	$\triangle$ 1-450-399-11	TRANSFORMER, POWER (K470)	
7	3-367-973-21	PANEL, BACK (K470:UK)					

**(2) FRONT PANEL SECTION**

- ▲B: MIC BOARD (TC-RX470)
- ▲C: DOLBY SW BOARD
- ▲D: REC VOL BOARD
- ▲E: POWER SW BOARD
- ▲F: H.P BOARD

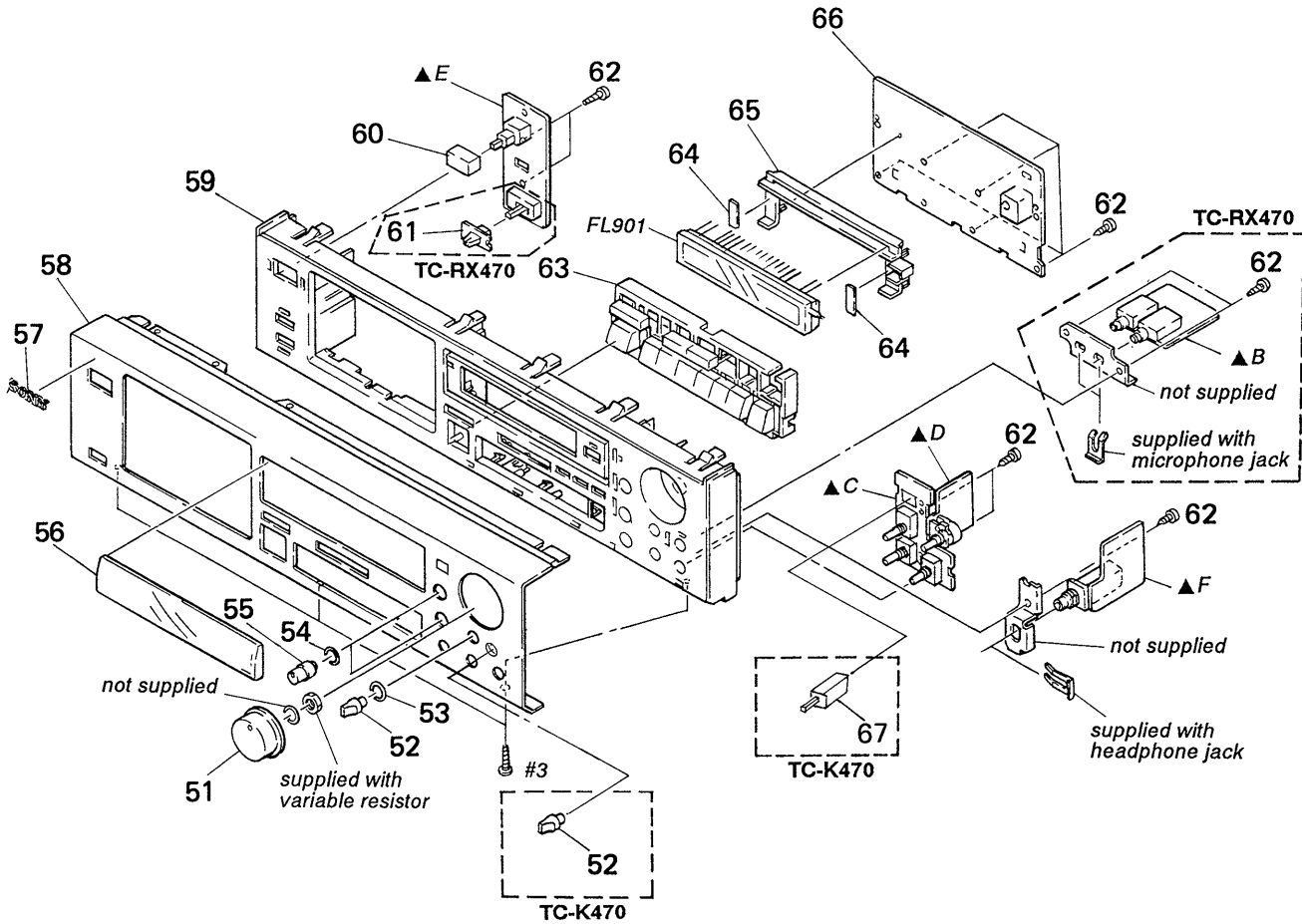

Ref.No.	Part No.	Description	Remark	Ref.No.	Part No.	Description	Remark
51	3-367-438-11	KNOB (REC)		60	4-922-921-01	BUTTON (POWER)	
52	3-350-495-01	KNOB (VOL)		61	4-931-421-11	KNOB (T & S) (RX470)	
53	3-370-186-01	SPRING (SWPA), RING		62	4-928-635-01	SCREW, +BV (2. 6X8) TAPPING	
54	3-356-957-01	SPRING		63	3-367-434-11	BUTTON (A) (RX470)	
55	3-367-431-01	KNOB (BAL)		63	3-368-281-11	BUTTON (B) (K470)	
56	3-367-433-11	WINDOW (METER)		64	9-911-844-XX	CUSHION	
57	4-908-848-01	EMBLEM, SONY		65	* 4-932-502-01	HOLDER, FL TUBE	
58	3-367-439-41	PANEL, FRONT (RX470)		66	* 1-638-310-11	PANEL BOARD	
58	3-368-282-61	PANEL, FRONT (K470)		67	3-350-473-01	BUTTON	
59	3-367-440-01	PANEL (BASE)					

(3) MECHANISM SECTION (1)  
 (TC-K470: TCM-200V6)  
 (TC-RX470: TCM-200R7)

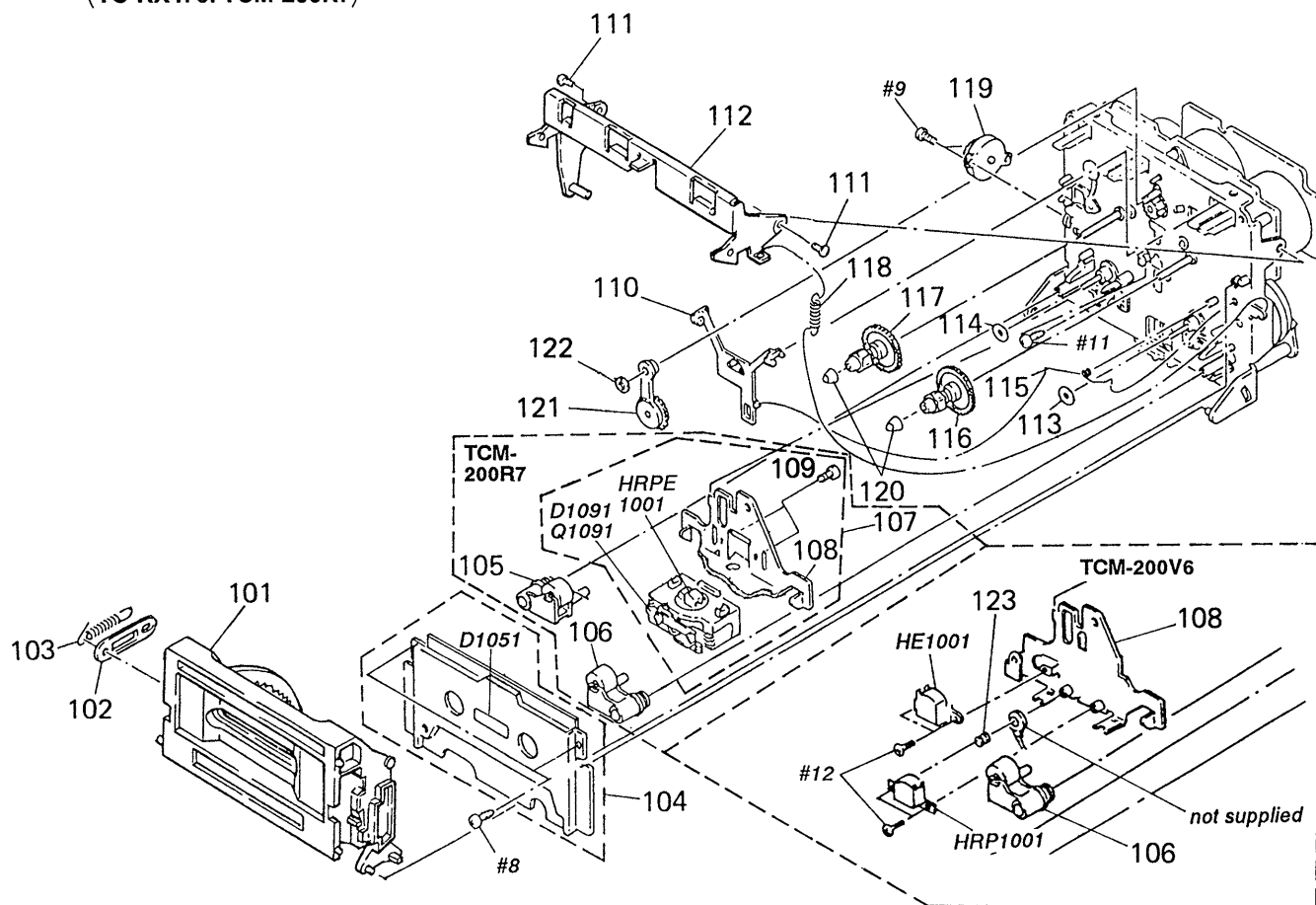

Ref. No.	Part No.	Description	Remark	Ref. No.	Part No.	Description	Remark
101	X-3362-814-1	HOLDER (CD) ASSY, CASSETTE		114	3-356-714-01	WASHER (200R7)	
102	* 3-356-717-01	LEVER (JOINT)		115	3-356-619-01	SPRING (B), TORSION	
103	3-356-626-01	SPRING, TENSION		116	X-3356-627-1	GEAR (T) ASSY	
104	X-3356-613-1	PLATE ASSY, ORNAMENTAL		117	X-3356-628-1	GEAR (S) ASSY	
105	* X-3343-456-1	LEVER (PINCH R) ASSY (200R7)		118	3-356-625-01	SPRING, TENSION	
106	* X-3343-455-1	LEVER (PINCH F) ASSY (200R7)		119	3-319-224-31	DAMPER, SMALL (200R7)	
106	* X-3356-649-1	LEVER (PINCH LEVER T) ASSY (200V6)		119	3-712-786-01	DAMPER, OIL (200V6)	
107	A-2003-723-A	BASE ASSY, HEAD	108, 109, D1091, Q1091 (200R7)	120	3-362-308-01	CAP (REEL)	
108	X-3356-647-1	SLIDER (HEAD CHASSIS V1) ASSY (200V6)		121	X-3356-641-1	LEVER (FR2) ASSY	
108	X-3362-819-2	SLIDER (HEAD CHASSIS R) ASSY (200R7)		122	3-669-465-00	WASHER (1.5), STOPPER	
109	3-356-716-01	SCREW (2X4) (B TIGHT), +P (200R7)		123	3-362-238-01	SPRING (VH), COMPRESSION (200V6)	
110	3-356-614-01	SLIDER (BRAKE)		D1051	8-719-980-85	DIODE SLF-325C	
111	3-356-601-11	SCREW, STEP		D1091	8-719-950-74	DIODE SLR-314D-B (200R7)	
112	* X-3356-608-1	LEVER (LIFTER) ASSY		HE1001	1-543-535-11	HEAD, MAGNETIC (ERASE) (200V6)	
113	3-356-713-01	WASHER		HRP1001	1-543-537-11	HEAD, MAGNETIC (REC/PB) (200V6)	
				Q1091	8-729-809-43	SPS-314B-BE (200R7)	



(4) MECHANISM SECTION (2)  
 (TC-K470: TCM-200V6)  
 (TC-RX470: TCM-200R7)

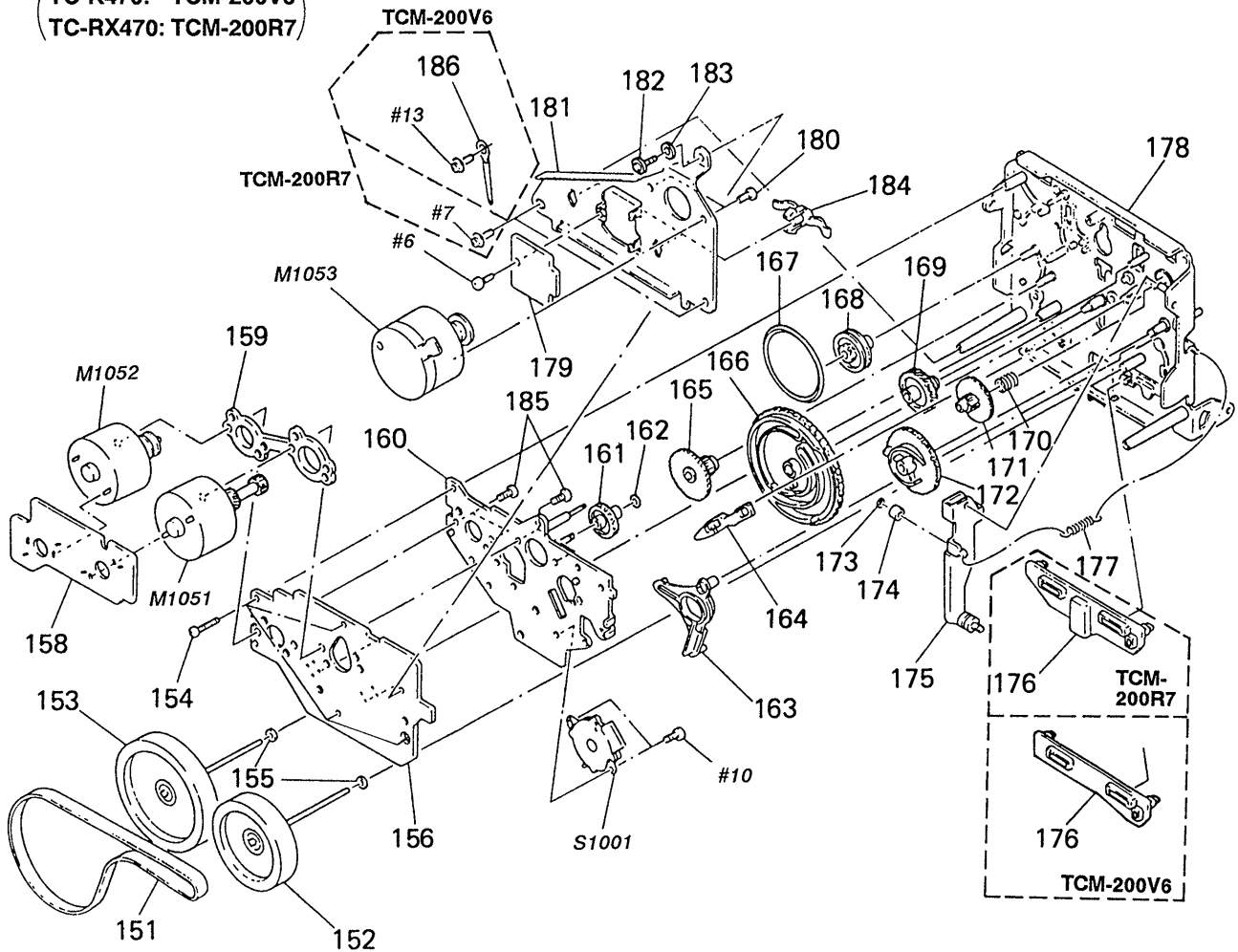

Ref.No.	Part No.	Description	Remark	Ref.No.	Part No.	Description	Remark
151	3-356-730-01	BELT (CAPSTAN R2) (200R7)		172	3-356-616-01	GEAR (LOADING CAM)	
151	3-356-744-01	BELT (CAPSTAN V) (200V6)		173	3-558-708-11	WASHER, STOPPER	
152	X-3356-642-1	FLYWHEEL (R FWD) ASSY		174	3-356-630-01	ROLLER (LOADING)	
153	X-3356-643-1	FLYWHEEL (R REV) ASSY (200R7)		175	* X-3356-606-1	LEVER (LOADING) ASSY	
154	3-355-801-01	SCREW (BTP 2X18)		176	3-356-612-01	SLIDER (REVERSE) (200R7)	
155	3-356-705-01	WASHER (CAPSTAN)		176	3-356-653-01	SLIDER (PAUSE) (200V6)	
156	* 1-632-740-11	MD BOARD		177	3-356-624-01	SPRING, TENSION	
158	* 1-632-741-11	REEL MOTOR BOARD		178	X-3356-634-1	CHASSIS (R2) COMPLETE ASSY, MECH (200R7)	
159	* 3-356-628-01	SPACER (MOTOR)		178	X-3356-644-1	CHASSIS COMPLETE ASSY, MECH (200V6)	
160	* X-3356-602-4	BRACKET (MOTOR R) ASSY		179	* 1-634-323-11	TRANSLATION BOARD (200R7)	
161	3-356-702-01	GEAR (COMMUNICATION B)		180	4-885-599-00	SCREW, FITTING, REINFORCEMENT	
162	3-669-465-00	WASHER (1.5), STOPPER		181	* 3-356-629-01	BRACKET (THRUST RETAINER R)	
163	3-356-613-01	LEVER (MODE)		182	3-356-707-01	SCREW (+PTPWH 2X25)	
164	3-356-617-01	LEVER (SELECTION)		183	* 3-356-718-01	SPACER (THRUST RETAINER R)	
165	3-356-606-01	GEAR (MODE)		184	3-575-321-00	RETAINER, THRUST, CAPSTAN	
166	3-356-615-01	GEAR (MODE CAM RR) (200R7)		185	3-363-804-01	SCREW (+P 2.6X6.5)	
166	3-356-747-01	GEAR (MODE CAM C) (200V6)		186	3-701-822-00	HOLDER, WIRE (200V6)	
167	3-356-603-01	BELT (MODE)		M1051	X-3356-638-1	MOTOR (REEL R) ASSY	
168	3-356-607-01	PULLEY (MODE)		M1052	X-3356-604-1	MOTOR (ASSIST) ASSY	
169	3-356-703-01	GEAR (COMMUNICATION C)		M1053	X-3356-646-1	MOTOR (CAPSTAN V1) ASSY	
170	3-356-605-01	SPRING, COMPRESSION		S1001	1-466-238-11	ENCODER, ROTARY (200V6)	
171	3-356-609-01	GEAR (LOADING)		S1001	1-466-525-11	ENCODER, ROTARY (200R7)	

## SECTION 6 ELECTRICAL PARTS LIST

MAIN

**NOTE:**

- Due to standardization, replacements in the parts list may be different from the parts specified in the diagrams or the components used on the set.
- -XX and -X mean standardized parts, so they may have some difference from the original one.
- **RESISTORS**  
All resistors are in ohms.  
METAL: Metal-film resistor  
METAL OXIDE: Metal Oxide-film resistor  
F: nonflammable

- Items marked "\*" are not stocked since they are seldom required for routine service. Some delay should be anticipated when ordering these items.
- **SEMICONDUCTORS**  
In each case, u:  $\mu$ , for example:  
uA...:  $\mu$ A..., uPA...:  $\mu$ PA...,  
uPB...:  $\mu$ PB..., uPC...:  $\mu$ PC...,  
uPD...:  $\mu$ PD...
- **CAPACITORS**  
uF:  $\mu$ F
- **COILS**  
uH:  $\mu$ H
- **FORMER:** The end of MAIN, MIC, DOLBY SW, REC VOL, POWER SW, H.P, TRANSFORMER, and COVER boards part Number; UP to -12.

The components identified by mark  $\Delta$  or dotted line with mark  $\Delta$  are critical for safety. Replace only with part number specified.

Les composants identifiés par une marque  $\Delta$  sont critiques pour la sécurité. Ne les remplacer que par une pièce portant le numéro spécifié.

When including parts by reference number, please include the board name.

Ref. No.	Part No.	Description	Remark	Ref. No.	Part No.	Description	Remark
* A-2006-466-A		MAIN BOARD, COMPLETE *****		C172	1-162-292-31	CERAMIC 680PF	10% 50V(RX470)
				C173	1-162-282-31	CERAMIC 100PF	10% 50V(RX470)
				C174	1-124-903-11	ELECT 1uF	20% 50V(RX470)
* 3-356-925-01		HEAT SINK		C201	1-124-907-11	ELECT 10uF	20% 50V
	7-682-547-04	SCREW +BVTT 3X6 (S)		C202	1-130-475-00	MYLAR 0.0022uF	5% 50V
		< CAPACITOR >		C203	1-130-475-00	MYLAR 0.0022uF	5% 50V
C101	1-124-907-11	ELECT 10uF	20% 50V	C204	1-130-475-00	MYLAR 0.0022uF	5% 50V
C102	1-130-475-00	MYLAR 0.0022uF	5% 50V	C205	1-136-174-00	FILM 0.56uF	5% 50V
C103	1-130-475-00	MYLAR 0.0022uF	5% 50V	C206	1-136-171-00	FILM 0.33uF	5% 50V
C104	1-130-475-00	MYLAR 0.0022uF	5% 50V	C207	1-124-907-11	ELECT 10uF	20% 50V
C105	1-136-174-00	FILM 0.56uF	5% 50V	C208	1-124-657-00	ELECT 10uF	20% 50V
C106	1-136-171-00	FILM 0.33uF	5% 50V	C213	1-162-284-31	CERAMIC 150PF	10% 50V
C107	1-124-907-11	ELECT 10uF	20% 50V	C214	1-136-273-91	FILM 75PF	5% 630V
C108	1-124-657-00	ELECT 10uF	20% 50V	C215	1-162-289-31	CERAMIC 390PF	10% 50V
C113	1-162-284-31	CERAMIC 150PF	10% 50V	C216	1-162-282-31	CERAMIC 100PF	10% 50V
C114	1-136-273-91	FILM 75PF	5% 630V	C217	1-136-157-00	FILM 0.022uF	5% 50V
C115	1-162-289-31	CERAMIC 390PF	10% 50V	C218	1-124-657-00	ELECT 10uF	20% 50V
C116	1-162-282-31	CERAMIC 100PF	10% 50V	C219	1-136-158-00	FILM 0.027uF	5% 50V
C117	1-136-157-00	FILM 0.022uF	5% 50V	C220	1-161-494-00	CERAMIC 0.022uF	25V
C118	1-124-657-00	ELECT 10uF	20% 50V	C222	1-136-153-00	FILM 0.01uF	5% 50V
C119	1-136-158-00	FILM 0.027uF	5% 50V	C223	1-136-157-00	FILM 0.022uF	5% 50V
C120	1-161-494-00	CERAMIC 0.022uF	25V	C224	1-136-165-00	FILM 0.1uF	5% 50V
C122	1-136-153-00	FILM 0.01uF	5% 50V	C225	1-136-433-11	FILM 100PF	5% 630V(K470)
C123	1-136-157-00	FILM 0.022uF	5% 50V	C225	1-136-437-11	FILM 220PF	5% 630V(RX470)
C124	1-136-165-00	FILM 0.1uF	5% 50V	C226	1-110-335-11	MYLAR 100PF	5% 50V
C125	1-136-433-11	FILM 100PF	5% 630V(K470)	C227	1-136-552-11	FILM 0.0012uF	5% 630V(RX470)
C125	1-136-437-11	FILM 220PF	5% 630V(RX470)	C227	1-136-553-11	FILM 0.0015uF	5% 630V(K470)
C126	1-110-335-11	MYLAR 100PF	5% 50V	C231	1-123-382-00	ELECT 3.3uF	20% 100V
C127	1-136-552-11	FILM 0.0012uF	5% 630V(RX470)	C241	1-124-611-00	ELECT 1uF	20% 50V(K470)
C127	1-136-553-11	FILM 0.0015uF	5% 630V(K470)	C241	1-124-657-00	ELECT 10uF	20% 50V(RX470)
C131	1-123-382-00	ELECT 3.3uF	20% 100V	C242	1-123-382-00	ELECT 3.3uF	20% 100V
C141	1-124-611-00	ELECT 1uF	20% 50V(K470)	C243	1-124-252-00	ELECT 0.33uF	20% 50V
C141	1-124-657-00	ELECT 10uF	20% 50V(RX470)	C271	1-124-903-11	ELECT 1uF	20% 50V(RX470)
C142	1-123-382-00	ELECT 3.3uF	20% 100V	C272	1-162-292-31	CERAMIC 680PF	10% 50V(RX470)
C143	1-124-252-00	ELECT 0.33uF	20% 50V	C273	1-162-282-31	CERAMIC 100PF	10% 50V(RX470)
C171	1-124-903-11	ELECT 1uF	20% 50V(RX470)				

## MAIN

Ref.No.	Part No.	Description	Remark	Ref.No.	Part No.	Description	Remark
C274	1-124-903-11	ELECT	1uF 20% 50V (RX470)	C809	1-124-907-11	ELECT	10uF 20% 50V
C501	1-124-907-11	ELECT	10uF 20% 50V	C810	1-161-494-00	CERAMIC	0.022uF 25V
C502	1-124-907-11	ELECT	10uF 20% 50V	C811	1-124-907-11	ELECT	10uF 20% 50V
C503	1-126-233-11	ELECT	22uF 20% 50V	C871	1-124-927-11	ELECT	4.7uF 20% 100V(RX470)
C507	1-124-443-00	ELECT	100uF 20% 10V	C872	1-124-477-11	ELECT	47uF 20% 25V(RX470)
C508	1-124-443-00	ELECT	100uF 20% 10V	C873	1-161-377-00	CERAMIC	0.0047uF 30% 16V(RX470)
C519	1-124-902-00	ELECT	0.47uF 20% 50V			< CONNECTOR >	
C520	1-124-477-11	ELECT	47uF 20% 25V	CNP501 *	1-564-337-00	PIN, CONNECTOR 3P	
C521	1-124-477-11	ELECT	47uF 20% 25V	CNP502 *	1-564-339-00	PIN, CONNECTORE 5P (RX470)	
C522	1-136-230-00	FILM	0.0022uF 5% 100V(RX470)	CNP503 *	1-564-336-00	PIN, CONNECTOR 2P	
C522	1-136-593-11	FILM	0.0033uF 5% 100V(K470)	CNP504 *	1-564-339-61	PIN, CONNECTOR 5P	
C523	1-136-230-00	FILM	0.0022uF 5% 100V(RX470)	CNP505 *	1-564-340-00	PIN, CONNECTOR 6P	
C523	1-136-593-11	FILM	0.0033uF 5% 100V(K470)	CNP506 *	1-564-338-00	PIN, CONNENTOR 4P (K470)	
C524	1-130-848-00	FILM	0.0082uF 5% 100V(K470)	CNP507 *	1-564-509-11	PLUG, CONNECTOR 6P	
C524	1-130-856-00	FILM	0.0068uF 5% 100V(RX470)	CNP508 *	1-564-506-11	PLUG, CONNECTOR 3P	
C525	1-136-157-00	FILM	0.022uF 5% 50V	CNP509 *	1-564-337-61	PIN, CONNECTOR 3P (K470)	
C526	1-124-907-11	ELECT	10uF 20% 50V	CNP602 *	1-564-337-61	PIN, CONNENTOR 3P (RX470)	
C527	1-136-601-11	FILM	0.01uF 5% 630V	CNP701 *	1-564-513-11	PLUG, CONNECTOR 10P	
C528	1-107-045-00	MICA	3.9PF 500V	CNP702 *	1-564-340-61	PIN, CONNENTOR 6P	
C545	1-162-217-31	CERAMIC	56PF 5% 50V	CNP801 *	1-580-784-11	PLUG, CONNECTOR	
C546	1-161-494-00	CERAMIC	0.022uF 25V	CNP802 *	1-580-784-11	PLUG, CONNECTOR	
C548	1-162-217-31	CERAMIC	56PF 5% 50V	CNP803 *	1-580-784-11	PLUG, CONNECTOR	
C549	1-124-925-11	ELECT	2.2uF 20% 100V	CNP804 *	1-580-784-11	PLUG, CONNECTOR	
C564	1-124-907-11	ELECT	10uF 20% 50V			< DIODE >	
C581	1-124-927-11	ELECT	4.7uF 20% 100V	D101	8-719-912-20	DIODE 1SS120	
C661	1-124-907-11	ELECT	10uF 20% 50V	D102	8-719-933-33	DIODE HZS6A1L	
C662	1-124-907-11	ELECT	10uF 20% 50V	D201	8-719-912-20	DIODE 1SS120	
C671	1-164-159-11	CERAMIC	0.1uF 50V(RX470)	D202	8-719-933-33	DIODE HZS6A1L	
C701	1-124-556-11	ELECT	2200uF 20% 16V	D504	8-719-912-20	DIODE 1SS120	
C702	1-124-556-11	ELECT	2200uF 20% 16V	D545	8-719-912-20	DIODE 1SS120	
C703	1-124-477-11	ELECT	47uF 20% 25V	D581	8-719-912-20	DIODE 1SS120	
C704	1-124-473-11	ELECT	1000uF 20% 10V	D582	8-719-912-20	DIODE 1SS120	
C705	1-124-473-11	ELECT	1000uF 20% 10V	D591	8-719-912-20	DIODE 1SS120 (K470)	
C706	1-124-907-11	ELECT	10uF 20% 50V	D592	8-719-912-20	DIODE 1SS120 (K470)	
C707	1-126-936-11	ELECT	3300uF 20% 16V	D701	8-719-200-77	DIODE 10E2N	
C708	1-124-907-11	ELECT	10uF 20% 50V	D702	8-719-200-77	DIODE 10E2N	
C709	1-126-916-11	ELECT	1000uF 20% 6.3V	D703	8-719-200-77	DIODE 10E2N	
C710	1-124-564-11	ELECT	4700uF 20% 25V	D704	8-719-200-77	DIODE 10E2N	
C711	1-124-907-11	ELECT	10uF 20% 50V	D705	8-719-933-33	DIODE HZS6A1L	
C712	1-124-360-00	ELECT	1000uF 20% 16V	D706	8-719-933-33	DIODE HZS6A1L	
C713	1-124-122-11	ELECT	100uF 20% 50V	D708	8-719-200-77	DIODE 10E2N (FORMER)	
C714	1-124-910-11	ELECT	47uF 20% 50V	D708	8-719-312-09	DIODE RBA-402	
C715	1-164-159-11	CERAMIC	0.1uF 50V	D709	8-719-200-77	DIODE 10E2N (FORMER)	
C801	1-162-294-31	CERAMIC	0.001uF 10% 50V	D710	8-719-200-77	DIODE 10E2N (FORMER)	
C802	1-162-294-31	CERAMIC	0.001uF 10% 50V	D711	8-719-200-77	DIODE 10E2N (FORMER)	
C803	1-164-159-11	CERAMIC	0.1uF 50V	D712	8-719-912-20	DIODE 1SS120	
C804	1-164-159-11	CERAMIC	0.1uF 50V	D713	8-719-200-77	DIODE 10E2N	
C805	1-164-159-11	CERAMIC	0.1uF 50V	D714	8-719-000-78	DIODE UZL-7L2-TP	
C806	1-124-477-11	ELECT	47uF 20% 25V	D715	8-719-912-20	DIODE 1SS120	
C807	1-126-176-11	ELECT	220uF 20% 10V				
C808	1-124-477-11	ELECT	47uF 20% 25V				

MAIN

Ref. No.	Part No.	Description	Remark	Ref. No.	Part No.	Description	Remark
D716	8-719-912-20	DIODE 1SS120		Q202	8-729-900-80	TRANSISTOR DTC114ES	
D717	8-719-001-70	DIODE UZL-12M1		Q203	8-729-142-25	TRANSISTOR 2SD1020-HFE	
D718	8-719-200-77	DIODE 10E2N		Q505	8-729-119-76	TRANSISTOR 2SA1175-HFE	
D719	8-719-200-77	DIODE 10E2N		Q506	8-729-900-80	TRANSISTOR DTC114ES	
D720	8-719-000-93	DIODE UZL-7H1		Q507	8-729-900-80	TRANSISTOR DTC114ES	
D801	8-719-912-20	DIODE 1SS120		Q508	8-729-900-80	TRANSISTOR DTC114ES	
D802	8-719-912-20	DIODE 1SS120		Q510	8-729-194-57	TRANSISTOR 2SC945-OP	
D803	8-719-912-20	DIODE 1SS120		Q511	8-729-194-57	TRANSISTOR 2SC545-OP	
D804	8-719-912-20	DIODE 1SS120		Q545	8-729-119-76	TRANSISTOR 2SA1175-HFE	
D805	8-719-912-20	DIODE 1SS120		Q561	8-729-900-80	TRANSISTOR DTC114ES	
D806	8-719-200-77	DIODE 10E2N		Q562	8-729-900-89	TRANSISTOR DTC144ES	
D810	8-719-912-20	DIODE 1SS120		Q581	8-729-620-05	TRANSISTOR 2SC2603-EF	
D871	8-719-912-20	DIODE 1SS120 (RX470)		Q591	8-729-900-65	TRANSISTOR DTA144ES	
D891	8-719-912-20	DIODE 1SS120		Q592	8-729-900-80	TRANSISTOR DTC114ES	
D892	8-719-912-20	DIODE 1SS120		Q702	8-729-900-80	TRANSISTOR DTC114ES	
D893	8-719-912-20	DIODE 1SS120		Q703	8-729-924-90	TRANSISTOR 2SB1370-EF	
		< IC >		Q704	8-729-111-55	TRANSISTOR 2SD1312-K	
IC501	8-759-111-44	IC $\mu$ PC4570C-1		Q705	8-729-111-55	TRANSISTOR 2SD1312-K	
IC502	8-752-035-94	IC CXA1331S		Q706	8-729-620-05	TRANSISTOR 2SC2603-EF	
IC503	8-752-055-61	IC CXA1578P		Q707	8-729-900-80	TRANSISTOR DTC114ES	
IC504	8-759-106-56	IC $\mu$ PC1297CA		Q708	8-729-924-90	TRANSISTOR 2SB1370-EF	
IC505	8-759-945-58	IC RC4558P		Q709	8-729-620-05	TRANSISTOR 2SC2603-EF	
IC506	8-759-945-58	IC RC4558P		Q710	8-729-119-76	TRANSISTOR 2SA1175-HFE	
IC661	8-759-634-51	IC M5218AP		Q711	8-729-140-04	TRANSISTOR 2SB1116A-LK	
IC671	8-759-634-50	IC M5218AL (RX470)		Q801	8-729-900-61	TRANSISTOR DTA114ES	
IC701	8-759-945-58	IC RC4558P		Q802	8-729-900-61	TRANSISTOR DTA114ES	
IC801	8-759-636-65	IC M50941-593SP		Q803	8-729-900-61	TRANSISTOR DTA114ES	
IC802	8-759-240-69	IC TC4069UBP		Q804	8-729-900-61	TRANSISTOR DTA114ES	
IC803	8-759-973-95	IC BA6219B		Q805	8-729-119-76	TRANSISTOR 2SA1175-HFE	
IC804	8-759-822-09	IC LB1641		Q806	8-729-119-76	TRANSISTOR 2SA1175-HFE	
		< JACK >		Q808	8-729-900-61	TRANSISTOR DTA114ES	
J171	1-507-854-00	JACK, PHONE (MICROPHONES-LEFT) (RX470)		Q809	8-729-620-05	TRANSISTOR 2SC2603-EF	
J271	1-507-854-00	JACK, PHONE (MICROPHONES-RIGHT) (RX470)		Q810	8-729-620-05	TRANSISTOR 2SC2603-EF	
J501	1-565-258-11	JACK, PIN 4P (LINE)		Q811	8-729-900-80	TRANSISTOR DTC114ES	
J561	1-507-796-71	JACK (HEADPHONES)		Q812	8-729-900-65	TRANSISTOR DTA144ES	
		< COIL >		Q813	8-729-900-80	TRANSISTOR DTC114ES	
L101	1-410-780-11	INDUCTOR 27mH		Q814	8-729-900-65	TRANSISTOR DTA144ES	
L201	1-410-780-11	INDUCTOR 27mH		Q815	8-729-900-89	TRANSISTOR DTC144ES	
		< FILTER >		Q816	8-729-900-89	TRANSISTOR DTC144ES	
LPF101	1-231-388-00	FILTER, LOW PASS		Q850	8-729-900-61	TRANSISTOR DTA114ES	
LPF201	1-231-388-00	FILTER, LOW PASS		Q851	8-729-900-61	TRANSISTOR DTA114ES	
		< TRANSISTOR >		Q852	8-729-900-61	TRANSISTOR DTA114ES	
Q101	8-729-900-74	TRANSISTOR DTC143TS		Q853	8-729-900-61	TRANSISTOR DTA114ES	
D102	8-729-900-80	TRANSISTOR DTC114ES		Q854	8-729-900-61	TRANSISTOR DTA114ES	
Q103	8-729-142-25	TRANSISTOR 2SD1020-HFE		Q855	8-729-900-61	TRANSISTOR DTA114ES	
Q201	8-729-900-74	TRANSISTOR DTC43TS		Q856	8-729-900-61	TRANSISTOR DTA114ES (K470)	
				Q871	8-729-620-05	TRANSISTOR 2SC2603-EF (RX470)	
				Q872	8-729-620-05	TRANSISTOR 2SC2603-EF (RX470)	

**MAIN**

Ref. No.	Part No.	Description	Remark	Ref. No.	Part No.	Description	Remark
< RESISTOR >							
R101	1-249-417-11	CARBON 1K	5% 1/4W	R207	1-249-421-11	CARBON 2. 2K	5% 1/4W
R102	1-247-887-00	CARBON 220K	5% 1/4W	R208	1-249-432-11	CARBON 18K	5% 1/4W
R103	1-249-423-11	CARBON 3. 3K	5% 1/4W	R209	1-249-421-11	CARBON 2. 2K	5% 1/4W
R104	1-249-428-11	CARBON 8. 2K	5% 1/4W	R210	1-249-433-11	CARBON 22K	5% 1/4W
R105	1-247-864-11	CARBON 24K	5% 1/4W	R211	1-249-417-11	CARBON 1K	5% 1/4W
R106	1-249-414-11	CARBON 560	5% 1/4W	R216	1-249-430-11	CARBON 12K	5% 1/4W
R107	1-249-421-11	CARBON 2. 2K	5% 1/4W	R217	1-247-881-00	CARBON 120K	5% 1/4W
R108	1-249-432-11	CARBON 18K	5% 1/4W	R218	1-249-403-11	CARBON 68	5% 1/4W
R109	1-249-421-11	CARBON 2. 2K	5% 1/4W	R219	1-247-882-11	CARBON 130K	5% 1/4W
R110	1-249-433-11	CARBON 22K	5% 1/4W	R220	1-249-426-11	CARBON 5. 6K	5% 1/4W
R111	1-249-417-11	CARBON 1K	5% 1/4W	R221	1-249-421-11	CARBON 2. 2K	5% 1/4W
R116	1-249-430-11	CARBON 12K	5% 1/4W	R222	1-247-840-00	CARBON 2. 4K	5% 1/4W
R117	1-247-881-00	CARBON 120K	5% 1/4W	R223	1-247-887-00	CARBON 220K	5% 1/4W
R118	1-249-403-11	CARBON 68	5% 1/4W	R224	1-249-417-11	CARBON 1K	5% 1/4W
Q119	1-247-882-11	CARBON 130K	5% 1/4W	R225	1-249-421-11	CARBON 2. 2K	5% 1/4W
R120	1-249-426-11	CARBON 5. 6K	5% 1/4W	R226	1-249-429-11	CARBON 10K	5% 1/4W
R121	1-249-421-11	CARBON 2. 2K	5% 1/4W	R227	1-249-430-11	CARBON 12K	5% 1/4W(K470)
R122	1-247-840-00	CARBON 2. 4K	5% 1/4W	R227	1-249-431-11	CARBON 15K	5% 1/4W(RX470)
R123	1-247-887-00	CARBON 220K	5% 1/4W	R228	△1-212-857-00	FUSIBLE 10	5% 1/4W F
R124	1-249-417-11	CARBON 1K	5% 1/4W	R229	1-247-883-00	CARBON 150K	5% 1/4W
R125	1-249-421-11	CARBON 2. 2K	5% 1/4W	R231	1-247-870-11	CARBON 43K	5% 1/4W
R126	1-249-429-11	CARBON 10K	5% 1/4W	R232	1-247-868-11	CARBON 36K	5% 1/4W
R127	1-249-430-11	CARBON 12K	5% 1/4W(K470)	R233	1-249-408-11	CARBON 180	5% 1/4W
	1-249-431-11	CARBON 15K	5% 1/4W(RX470)	R234	1-249-434-11	CARBON 27K	5% 1/4W
R128	△1-212-857-00	FUSIBLE 10	5% 1/4W F	R241	1-249-429-11	CARBON 10K	5% 1/4W
R129	1-247-883-00	CARBON 150K	5% 1/4W	R242	1-249-423-11	CARBON 3. 3K	5% 1/4W
R131	1-247-870-11	CARBON 43K	5% 1/4W	R261	1-249-432-11	CARBON 18K	5% 1/4W
R132	1-247-868-11	CARBON 36K	5% 1/4W	R262	1-249-421-11	CARBON 2. 2K	5% 1/4W
R133	1-249-408-11	CARBON 180	5% 1/4W	R263	1-249-429-11	CARBON 10K	5% 1/4W(RX470)
R134	1-249-434-11	CARBON 27K	5% 1/4W	R263	1-247-856-00	CARBON 11K	5% 1/4W(K470)
R141	1-249-429-11	CARBON 10K	5% 1/4W	R264	1-249-409-11	CARBON 220	5% 1/4W
R142	1-249-423-11	CARBON 3. 3K	5% 1/4W	R265	1-249-432-11	CARBON 18K	5% 1/4W(RX470)
R161	1-249-432-11	CARBON 18K	5% 1/4W	R271	1-249-441-11	CARBON 100K	5% 1/4W(RX470)
R162	1-249-421-11	CARBON 2. 2K	5% 1/4W	R272	1-249-429-11	CARBON 10K	5% 1/4W(RX470)
R163	1-247-856-00	CARBON 11K	5% 1/4W(K470)	R273	1-249-441-11	CARBON 100K	5% 1/4W(RX470)
R163	1-249-429-11	CARBON 10K	5% 1/4W(RX470)	R274	1-249-437-11	CARBON 47K	5% 1/4W(RX470)
R164	1-249-409-11	CARBON 220	5% 1/4W	R275	1-249-411-11	CARBON 330	5% 1/4W(RX470)
R165	1-249-432-11	CARBON 18K	5% 1/4W(RX470)	R501	1-249-417-11	CARBON 1K	5% 1/4W
R171	1-249-441-11	CARBON 100K	5% 1/4W(RX470)	R504	1-249-429-11	CARBON 10K	5% 1/4W
R172	1-249-429-11	CARBON 10K	5% 1/4W(RX470)	R505	1-215-455-00	METAL 27K	5% 1/4W
R173	1-249-441-11	CARBON 100K	5% 1/4W(RX470)	R530	1-249-409-11	CARBON 220	5% 1/4W
R174	1-249-437-11	CARBON 47K	5% 1/4W(RX470)	R531	1-249-409-11	CARBON 220	5% 1/4W
R175	1-249-411-11	CARBON 330	5% 1/4W(RX470)	R532	1-249-429-11	CARBON 10K	5% 1/4W
R201	1-249-417-11	CARBON 1K	5% 1/4W	R533	1-249-429-11	CARBON 10K	5% 1/4W
R202	1-247-887-00	CARBON 220K	5% 1/4W	R535	1-247-836-11	CARBON 1. 6K	5% 1/4W(RX470)
R203	1-249-423-11	CARBON 3. 3K	5% 1/4W	R535	1-249-419-11	CARBON 1. 5K	5% 1/4W(K470)
R204	1-249-428-11	CARBON 8. 2K	5% 1/4W	R536	1-247-848-11	CARBON 5. 1K	5% 1/4W(K470)
R205	1-247-864-11	CARBON 24K	5% 1/4W	R536	1-249-425-11	CARBON 4. 7K	5% 1/4W(RX470)
R206	1-249-414-11	CARBON 560	5% 1/4W	R537	1-249-420-11	CARBON 1. 8K	5% 1/4W
				R538	1-247-860-11	CARBON 16K	5% 1/4W

<p><b>Note:</b> The components identified by mark △ or dotted line with mark △ are critical for safety. Replace only with part number specified.</p>	<p><b>Note:</b> Les composants identifiés par une marque △ sont critiques pour la sécurité. Ne les remplacer que par une pièce portant le numéro spécifié.</p>
--	--

MAIN

Ref. No.	Part No.	Description	Remark			Ref. No.	Part No.	Description	Remark		
R539	1-249-438-11	CARBON	56K	5%	1/4W (K470)	R719	1-249-428-11	CARBON	8. 2K	5%	1/4W
R539	1-249-441-11	CARBON	100K	5%	1/4W (RX470)	R720	1-249-437-11	CARBON	47K	5%	1/4W
R540	1-249-438-11	CARBON	56K	5%	1/4W (K470)	R740	△ 1-219-135-11	FUSIBLE	0. 15	10%	1/4W
R540	1-249-441-11	CARBON	100K	5%	1/4W (RX470)	R741	△ 1-219-137-11	FUSIBLE	0. 33	10%	1/4W
R541	1-249-390-11	CARBON	5. 6	5%	1/6W	R801	1-247-887-00	CARBON	220K	5%	1/4W
R542	1-249-390-11	CARBON	5. 6	5%	1/6W	R802	1-247-887-00	CARBON	220K	5%	1/4W
R545	1-249-441-11	CARBON	100K	5%	1/4W	R803	1-249-436-11	CARBON	39K	5%	1/4W
R546	1-249-441-11	CARBON	100K	5%	1/4W	R804	1-247-887-00	CARBON	220K	5%	1/4W
R547	1-249-429-11	CARBON	10K	5%	1/4W	R805	1-249-436-11	CARBON	39K	5%	1/4W
R548	1-249-428-11	CARBON	8. 2K	5%	1/4W	R806	1-247-887-00	CARBON	220K	5%	1/4W
R549	1-249-441-11	CARBON	100K	5%	1/4W	R807	1-249-430-11	CARBON	12K	5%	1/4W
R550	1-249-441-11	CARBON	100K	5%	1/4W	R808	1-249-435-11	CARBON	33K	5%	1/4W
R551	1-249-423-11	CARBON	3. 3K	5%	1/4W	R809	1-249-435-11	CARBON	33K	5%	1/4W
R552	1-249-429-11	CARBON	10K	5%	1/4W	R810	1-249-435-11	CARBON	33K	5%	1/4W
R553	1-249-429-11	CARBON	10K	5%	1/4W	R811	1-249-435-11	CARBON	33K	5%	1/4W
R554	1-249-417-11	CARBON	1K	5%	1/4W	R812	1-249-435-11	CARBON	33K	5%	1/4W
R563	1-215-454-00	METAL	24K	5%	1/6W	R813	1-249-435-11	CARBON	33K	5%	1/4W
R564	1-249-429-11	CARBON	10K	5%	1/4W	R814	1-249-435-11	CARBON	33K	5%	1/4W
R565	1-247-842-11	CARBON	3K	5%	1/4W	R818	1-249-429-11	CARBON	10K	5%	1/4W
R566	1-249-433-11	CARBON	22K	5%	1/4W	R819	1-249-429-11	CARBON	10K	5%	1/4W (RX470)
R567	1-249-429-11	CARBON	10K	5%	1/4W	R820	1-249-432-11	CARBON	18K	5%	1/4W (RX470)
R568	1-249-421-11	CARBON	2. 2K	5%	1/4W	R821	△ 1-212-954-11	FUSIBLE	6. 8	5%	1/2W F
R570	1-249-429-11	CARBON	10K	5%	1/4W	R822	1-249-429-11	CARBON	10K	5%	1/4W
R581	1-249-421-11	CARBON	2. 2K	5%	1/4W	R823	1-249-431-11	CARBON	15K	5%	1/4W
R582	1-249-431-11	CARBON	15K	5%	1/4W	R824	1-247-834-11	CARBON	1. 3K	5%	1/4W
R583	1-249-429-11	CARBON	10K	5%	1/4W	R825	1-249-424-11	CARBON	3. 9K	5%	1/4W
R591	1-249-413-11	CARBON	470	5%	1/4W	R826	1-249-428-11	CARBON	8. 2K	5%	1/4W
R592	1-249-413-11	CARBON	470	5%	1/4W	R827	1-249-427-11	CARBON	6. 8K	5%	1/4W
R601	1-247-838-00	CARBON	2K	5%	1/4W (RX470)	R828	1-249-428-11	CARBON	8. 2K	5%	1/4W
R681	1-247-838-00	CARBON	2K	5%	1/4W	R829	1-212-952-00	FUSIBLE	5. 6	5%	1/2W F
R691	1-219-135-11	FUSIBLE	0. 15	10%	1/4W (FORMER)	R830	1-249-435-11	CARBON	33K	5%	1/4W
R692	1-219-135-11	FUSIBLE	0. 15	10%	1/4W (FORMER)	R831	1-249-435-11	CARBON	33K	5%	1/4W
R701	1-249-425-11	CARBON	4. 7K	5%	1/4W	R832	1-249-432-11	CARBON	18K	5%	1/4W
R702	1-249-420-11	CARBON	1. 8K	5%	1/4W	R833	1-249-423-11	CARBON	3. 3K	5%	1/4W
R703	1-249-412-11	CARBON	390	5%	1/4W	R834	1-247-903-00	CARBON	1M	5%	1/4W
R704	1-249-427-11	CARBON	6. 8K	5%	1/4W	R840	△ 1-212-942-00	FUSIBLE	2. 2	5%	1/2W
R705	1-249-419-11	CARBON	1. 5K	5%	1/4W	R851	1-249-441-11	CARBON	100K	5%	1/4W
R706	1-249-429-11	CARBON	10K	5%	1/4W	R852	1-249-441-11	CARBON	100K	5%	1/4W
R707	1-249-419-11	CARBON	1. 5K	5%	1/4W	R853	1-249-441-11	CARBON	100K	5%	1/4W
R708	1-249-425-11	CARBON	4. 7K	5%	1/4W	R854	1-249-441-11	CARBON	100K	5%	1/4W
R709	1-249-409-11	CARBON	220	5%	1/4W	R855	1-249-441-11	CARBON	100K	5%	1/4W
R710	1-249-417-11	CARBON	1K	5%	1/4W	R856	1-249-441-11	CARBON	100K	5%	1/4W (K470)
R711	1-249-427-11	CARBON	6. 8K	5%	1/4W	R861	1-249-429-11	CARBON	10K	5%	1/4W
R712	1-249-427-11	CARBON	6. 8K	5%	1/4W	R862	1-249-437-11	CARBON	47K	5%	1/4W
R713	1-249-417-11	CARBON	1K	5%	1/4W	R871	1-249-410-11	CARBON	270	5%	1/4W (RX470)
R714	1-249-425-11	CARBON	4. 7K	5%	1/4W	R872	1-249-421-11	CARBON	2. 2K	5%	1/4W (RX470)
R715	1-249-425-11	CARBON	4. 7K	5%	1/4W	R873	1-249-429-11	CARBON	10K	5%	1/4W (RX470)
R716	1-249-425-11	CARBON	4. 7K	5%	1/4W	R874	1-249-429-11	CARBON	10K	5%	1/4W (RX470)
R717	1-249-433-11	CARBON	22K	5%	1/4W	R875	1-249-433-11	CARBON	22K	5%	1/4W (RX470)
R718	1-247-866-11	CARBON	30K	5%	1/4W	R876	1-249-429-11	CARBON	10K	5%	1/4W (RX470)

**Note:**  
The components identified by mark △ or dotted line with mark △ are critical for safety. Replace only with part number specified.

**Note:**  
Les composants identifiés par une marque △ sont critiques pour la sécurité. Ne les remplacer que par une pièce portant le numéro spécifié.

MAIN

MD

PANEL

Ref. No.	Part No.	Description	Remark
R877	1-249-417-11	CARBON 1K 5% 1/4W(RX470)	
R878	1-249-413-11	CARBON 470 5% 1/4W(RX470)	
R891	1-249-403-11	CARBON 68 5% 1/4W	
R999	1-249-417-11	CARBON 1K 5% 1/4W(K470)	
< VARIABLE RESISTOR >			
RV101	1-238-600-11	RES, ADJ, CARBON 10K	
RV103	1-238-601-11	RES, ADJ, CARBON 22K	
RV141	1-238-600-11	RES, ADJ, CARBON 10K	
RV201	1-238-600-11	RES, ADJ, CARBON 10K	
RV203	1-238-601-11	RES, ADJ, CARBON 22K	
RV241	1-238-600-11	RES, ADJ, CARBON 10K	
RV681	1-241-431-11	RES, VAR, CARBON 50K/50K (REC LEVEL)	
RV682	1-238-904-11	RES, VAR, CARBON 50K/50K (BALANCE)	
RV683	1-241-046-11	RES, VAR, CARBON 5K (BIAS)	
RV871	1-238-602-11	RES, ADJ, CARBON 47K (RX470)	
RV561	1-238-085-11	RES, VAR, CARBON 20K/20K (PHONE LEVEL) (K470)	
< RELAY >			
RY581	1-515-683-11	RELAY	
< SWITCH >			
S601	1-554-118-00	SWITCH, PUSH (1 KEY) (POWER)	
S602	1-571-520-11	SWITCH, SLIDE (DIRECTION) (RX470)	
S603	1-572-154-11	SWITCH, ROTARY (DOLBY NR)	
S604	1-554-118-00	SWITCH, PUSH (1 KEY) (MPX FILTER) (K470)	
< TRANSFORMER >			
T101	1-433-367-11	TRANSFORMER, BIAS OSCILLATION (RX470)	
T101	1-433-385-11	TRANSFORMER, BIAS OSCILLATION (K470)	
T201	1-433-367-11	TRANSFORMER, BIAS OSCILLATION (RX470)	
T201	1-433-385-11	TRANSFORMER, BIAS OSCILLATION (K470)	
T501	1-433-355-11	TRANSFORMER, BIAS OSCILLATION (K470)	
T501	1-433-366-11	TRANSFORMER, BIAS OSCILLATION (RX470)	
< TEST PIN >			
TP501	* 1-564-506-11	PLUG, CONNECTOR 3P	
TP801	* 1-564-505-11	PLUG, CONNECTOR 2P	
TP802	* 1-564-505-11	PLUG, CONNECTOR 2P (RX470)	
TP803	* 1-564-506-11	PLUG, CONNECTOR 3P	
< CERAMIC >			
X801	1-577-359-21	VIBRATOR, CERAMIC (4.19MHz)	
*****			
	* 1-632-740-11	MD BOARD	
		*****	
	3-356-631-01	HOLDER (SENSOR)	

Ref. No.	Part No.	Description	Remark
< CONNECTOR >			
CN1001	1-506-615-11	PIN, CONNECTOR 9P	
CN1002	1-564-501-11	PIN, CONNECTOR 8P (K470)	
CN1002	1-564-502-11	PIN, CONNECTOR 10P (RX470)	
< IC >			
IC1001	8-749-920-97	IC PHOTO REFLECTOR GP2S22B	
IC1002	8-749-920-97	IC PHOTO REFLECTOR GP2S22B	
< RESISTOR >			
R1001	1-249-408-11	CARBON 180 5% 1/4W	
R1002	1-249-408-11	CARBON 180 5% 1/4W	
< SWITCH >			
S1002	1-570-953-11	SWITCH, PUSH (1 KEY) (DOOR)	
S1003	1-571-958-11	SWITCH, PUSH (1 KEY) (CLOSE)	
S1004	1-572-126-11	SWITCH, PUSH (1 KEY) (OPEN)	
S1005	1-572-125-11	SWITCH, LEAF (REC FWD)	
S1006	1-572-202-11	SWITCH, LEAF (HALF)	
S1007	1-572-125-11	SWITCH, LEAF (METAL)	
S1008	1-572-125-11	SWITCH, LEAF (70u)	
S1009	1-572-125-11	SWITCH, LEAF (REC REV) (RX470)	
< CONNECTOR >			
TB1001	* 1-659-066-11	PIN, CONNECTOR 5P	
*****			
	* 1-638-310-11	PANEL BOARD	
		*****	
	* 4-932-502-01	HOLDER, FL TUBE	
	9-911-844-XX	CUSHION	
< CAPACITOR >			
C901	1-124-589-11	ELECT 47u 20% 16V	
< CONNECTOR >			
CN901	* 1-580-782-11	SOCKET, CONNECTOR	
CN902	* 1-580-782-11	SOCKET, CONNECTOR	
CN903	* 1-580-782-11	SOCKET, CONNECTOR	
CN904	* 1-580-782-11	SOCKET, CONNECTOR	
< DIODE >			
D901	8-719-912-20	DIODE 1SS120	
D902	8-719-912-20	DIODE 1SS120	
D903	8-719-912-20	DIODE 1SS120	
D904	8-719-912-20	DIODE 1SS120	

**PANEL**

**REEL MOTOR**

**TRANSLATION**

**SENSOR**

Ref.No.	Part No.	Description	Remark
		< FLUORESCENT INDICATOR >	
FL901	1-519-657-11	INDICATOR TUBE, FLUORESCENT (K470)	
FL901	1-519-658-11	INDICATOR TUBE, FLUORESCENT (RX470)	
		< IC >	
IC901	8-741-100-48	IC SBX1610-59	
		< RESISTOR >	
R901	1-249-421-11	CARBON 2.2K 5% 1/4W	
R902	1-247-842-11	CARBON 3K 5% 1/4W	
R903	1-249-426-11	CARBON 5.6K 5% 1/4W	
R904	1-247-854-11	CARBON 9.1K 5% 1/4W	
R905	1-249-848-11	CARBON 5.1K 5% 1/4W(K470)	
R905	1-249-421-11	CARBON 2.2K 5% 1/4W(RX470)	
R906	1-247-842-11	CARBON 3K 5% 1/4W(RX470)	
R907	1-249-426-11	CARBON 5.6K 5% 1/4W	
R908	1-249-854-11	CARBON 9.1K 5% 1/4W	
R909	1-249-434-11	CARBON 27K 5% 1/4W	
R910	1-249-429-11	CARBON 10K 5% 1/4W	
R911	1-249-429-11	CARBON 10K 5% 1/4W	
R912	1-249-441-11	CARBON 100K 5% 1/4W	
R913	1-249-441-11	CARBON 100K 5% 1/4W	
		< SWITCH >	
S901	1-554-303-21	SWITCH, TACTILE (OPEN/CLOSE)	
S902	1-554-303-21	SWITCH, TACTILE (STOP)	
S903	1-554-303-21	SWITCH, TACTILE (REW)	
S904	1-554-303-21	SWITCH, TACTILE (FF)	
S905	1-554-303-21	SWITCH, TACTILE (REC)	
S906	1-554-303-21	SWITCH, TACTILE (FWD) (RX470)	
S907	1-554-303-21	SWITCH, TACTILE (FWD) (K470)	
S908	1-554-303-21	SWITCH, TACTILE (PAUSE)	
S909	1-554-303-21	SWITCH, TACTILE (REV)	
S910	1-554-303-21	SWITCH, TACTILE (REC MUTE)	
S911	1-554-303-21	SWITCH, TACTILE (RESET)	
S912	1-554-303-21	SWITCH, TACTILE (MEMORY)	
*****			
	* 1-632-741-11	REEL MOTOR BOARD	*****
M1051	X-3356-638-1	MOTOR (REEL R) ASSY	
M1052	X-3356-604-1	MOTOR (ASSIST) ASSY	
		< CAPACITOR >	
C1051	1-124-907-11	ELECT 10uF 20% 50V	
C1052	1-124-907-11	ELECT 10uF 20% 50V	
C1053	1-164-159-11	CERAMIC 0.1uF 50V	

Ref.No.	Part No.	Description	Remark
		< CONNECTOR >	
CN1051	1-564-499-11	PIN, CONNECTOR 6P	
CN1052	* 1-564-718-11	PIN, CONNECTOR (SMALL TYPE) 2P	
CN1053	* 1-564-718-11	PIN, CONNECTOR (SMALL TYPE) 2P	
		< RESISTOR >	
R1051	1-249-414-11	CARBON 560 5% 1/4W	
*****			
	* 1-634-323-11	TRANSLATION BOARD	*****
		< CONNECTOR >	
CN1091	* 1-564-709-11	PIN, CONNECTOR (SMALL TYPE) 7P	
CN1092	* 1-564-509-11	PLUG, CONNECTOR 6P	
CN1093	* 1-564-705-11	PIN, CONNECTOR (SMALL TYPE) 3P	
CN1094	* 1-564-506-11	PLUG, CONNECTOR 3P	
*****			
	1-638-161-11	SENSOR BOARD	*****
		< DIODE >	
D1091	8-719-950-74	DIODE SLR-314D-B (200R7)	
		< TRANSISTOR >	
Q1091	8-729-809-43	SPS-314B-BE (200R7)	
*****			
		MISCELLANEOUS	
		*****	
5	△1-551-506-XX	CORD, POWER	
5	△1-555-795-00	CORD, POWER, EURO PLUG (K470:AEP, Germany)	
5	△1-556-035-00	CORD, POWER (K470:UK)	
D1051	8-719-980-85	DIODE SLF-325C	
M1053	X-3356-646-1	MOTOR (CAPSTAN V1) ASSY	
S1001	1-466-238-11	ENCODER, ROTARY (200V6)	
S1001	1-466-525-11	ENCODER, ROTARY (200R7)	
T901	△1-450-100-11	TRANSFORMER, POWER (RX470)	
T901	△1-450-399-11	TRANSFORMER, POWER (K470)	
*****			
		ACCESSORY & PACKING MATERIAL	
		*****	
	1-559-533-11	CORD, CONNECTION	
	* 3-350-830-01	CUSHION	
	* 3-366-700-31	INDIVIDUAL CARTON (RX470)	
	* 3-366-700-71	INDIVIDUAL CARTON (K470)	

<p><b>Note:</b> The components identified by mark △ or dotted line with mark △ are critical for safety. Replace only with part number specified.</p>	<p><b>Note:</b> Les composants identifiés par une marque △ sont critiques pour la sécurité. Ne les remplacer que par une pièce portant le numéro spécifié.</p>
--	--



<u>Ref.No.</u>	<u>Part No.</u>	<u>Description</u>	<u>Remark</u>
	3-703-450-01	INSTRUCTION (RX470)	
*	3-704-343-01	SHEET (STANDARD), PROTECTION	
	3-753-217-21	MANUAL, INSTRUCTION (ENGLISH) (RX470:US)	
	3-753-217-31	MANUAL, INSTRUCTION (ENGLISH, FRENCH) (RX470:Canadian)	
	3-753-360-11	MANUAL, INSTRUCTION (ENGLISH, FRENCH, SPANISH, PORTUGUESE) (K470:AEP, UK)	
	3-753-360-41	MANUAL, INSTRUCTION (GERMAN, DUTCH, SWEDISH, ITALIAN) (K470:AEP)	
	3-753-360-51	MANUAL, INSTRUCTION (GERMAN) (K470:GERMANY)	

\*\*\*\*\*

**HARDWARE LIST**

#1	7-682-547-04	SCREW +BVTT 3X6 (S)
#2	7-685-646-79	SCREW +BVTP 3X8 TYPE2 N-S
#3	7-685-534-19	SCREW +BTP 2. 6X8 TYPE2 N-S
#6	7-621-770-67	SCREW +BVTT 2. 6X6 (S)
#7	7-685-131-19	SCREW +BTP 2. 6X4 TYPE2 N-S
#8	7-685-133-19	SCREW +BTP 2. 6X6 TYPE2 N-S
#9	7-621-255-20	SCREW +BVTT 2X4 (S)
#10	7-621-255-35	SCREW +BVTT 2X5 (S)
#11	7-621-283-00	SCREW +BVTT 2X5 (S)
#12	7-621-772-20	SCREW +B2X5
#13	7-685-132-19	SCREW +BTP 2. 6X5 TYPE2 N-S