

# TC-K500

## SERVICE MANUAL

Germany Model



Model Name Using Similar Mechanism	TC-W 550
Tape Transport Mechanism Type	TCM-CMAY B-26

### SPECIFICATIONS

Aufnahmesystem 4 Spuren, 2-Kanal-Stereo  
 Vormagnetisierung Wechselstrom  
 Köpfe Löschkopf × 1 (F & F)  
 Aufnahme/Wiedergabe-Kopf × 1 (Laseramorphous)  
 Motoren Capstan-Motor × 1 (Gleichstromservo-Typ)  
 Aufwickel/Abwickel-Motor × 1 (Gleichstrom-Typ)  
 Gleichlaufschwankungen ±0,14% W Peak (DIN)  
 Umspulzeit ca. 90 Sek. (mit C-60-Cassette)

Frequenzgang (Dolby ausgeschaltet)

TYPE IV-Cassette (Sony METAL-ES)	30–18.000 Hz (±3 dB, DIN) 30–15.000 Hz (±3 dB, 0VU Aufnahme)
TYPE II-Cassette (Sony UX-S)	30–17.000 Hz (±3 dB, DIN)
TYPE I-Cassette (Sony HF-S)	30–15.000 Hz (±3 dB, DIN)

Signal-Rauschabstand (bei Spitzenpegel)

Dolby NR-Schalter Cassette	OFF	B-TYPE ON	C-TYPE ON
TYPE IV (Sony METAL-ES)	59 dB	66 dB	72 dB
TYPE II (Sony UX-S)	58 dB	65 dB	71 dB
TYPE I (Sony HF-S)	54 dB	61 dB	67 dB

Gesamtklirgrad 1,0% (mit Sony METAL-ES-Cassette)  
 Eingänge

Line-Eingänge (Cinchbuchsen)	Empfindlichkeit	77,5 mV (–20 dB)
	Eingangsimpedanz	50 kOhm

Ausgänge

Line-Ausgänge (Cinchbuchsen)	Nennausgangspegel	0,44 V (–5 dB) bei Lastimpedanz von 47 kOhm
	Lastimpedanz	über 10 kOhm
Kopfhörerausgang (Stereo-Klinkenbuchse)	Ausgangspegel	0–2,5 mW bei Lastimpedanz von 32 Ohm

Allgemeine Daten

Stromversorgung 220 V Wechselspannung, 50/60 Hz  
 Leistungsaufnahme 20 W  
 Abmessungen ca. 430 × 118 × 345 mm (B/H/T) einschl. vorspringender Teile und Bedienungselemente  
 Gewicht ca. 5,2 kg  
 Mitgeliefertes Zubehör Audio-Verbindungskabel (2)

STEREO CASSETTE DECK  
**SONY**®

TABLE OF CONTENTS

<u>Section</u>	<u>Title</u>	<u>Page</u>	<u>Section</u>	<u>Title</u>	<u>Page</u>
SPECIFICATIONS .....		1	<b>SECTION 5 EXPLODED VIEWS</b> .....		18
<b>SECTION 1 GENERAL</b> .....		2	5-1. CABINET SECTION .....		18
1-1. LOCATION AND FUNCTION OF CONTROLS		2	5-2. FRONT PANEL SECTION .....		19
<b>SECTION 2 MECHANICAL ADJUSTMENTS</b> .....		3	<b>SECTION 6 ELECTRICAL PARTS LIST</b> .....		20
<b>SECTION 3 ELECTRICAL ADJUSTMENTS</b> .....		3			
<b>SECTION 4 DIAGRAMS</b>					
4-1. SEMICONDUCTOR LEAD LAYOUTS .....		6			
4-2. PRINTED WIRING BOARDS .....		7			
4-3. SCHEMATIC DIAGRAM					
—AUDIO/SYSTEM CONTROL SECTION— .....		11			
4-4. SCHEMATIC DIAGRAM					
—DISPLAY SECTION— .....		16			

**SAFETY-RELATED COMPONENT WARNING!!**

COMPONENTS IDENTIFIED BY MARK  $\Delta$  OR DOTTED LINE WITH MARK  $\Delta$  ON THE SCHEMATIC DIAGRAMS AND IN THE PARTS LIST ARE CRITICAL TO SAFE OPERATION. REPLACE THESE COMPONENTS WITH SONY PARTS WHOSE PART NUMBERS APPEAR AS SHOWN IN THIS MANUAL OR IN SUPPLEMENTS PUBLISHED BY SONY.

**SECTION 1  
GENERAL**

**1-1. LOCATION AND FUNCTION OF CONTROLS**

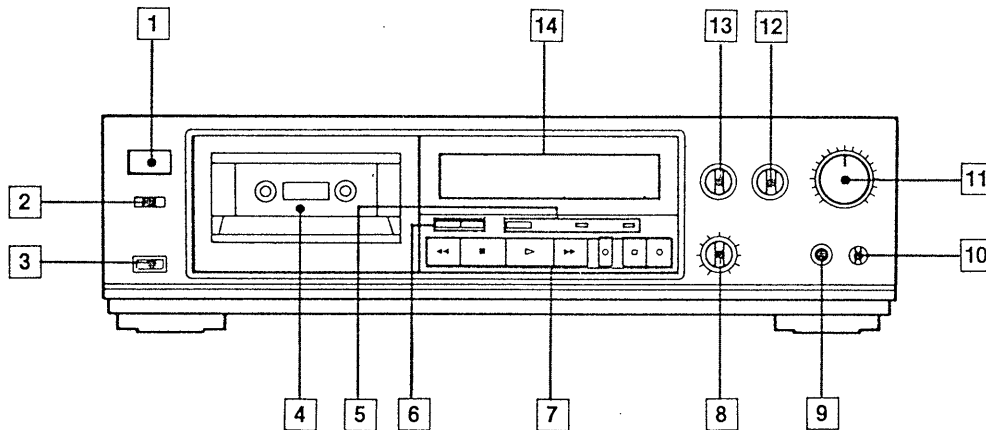

- |  |   |
|--|---|
| <p><b>1</b> Netzschalter (POWER)</p> <p><b>2</b> Timerschalter (TIMER)</p> <p><b>3</b> Auswurfaste (<math>\blacktriangle</math>)</p> <p><b>4</b> Cassettenhalter</p> <p><b>5</b> Betriebsartentaste (TAPE OPERATION)<br/>AMS/Leerstellensprung-Anzeige (AMS/BLANK SKIP)<br/>und Anspielautomatik-Anzeige (MUSIC SCAN)</p> <p><b>6</b> Zählertasten (COUNTER)<br/>Rückstellaste/Speichertaste (RESET/MEMORY)</p> <p><b>7</b> Bandlauf-Funktionstasten und Anzeigen<br/>Rückspultaste (<math>\blacktriangleleft</math>)<br/>Stopptaste (<math>\blacksquare</math>)<br/>Wiedergabetaste und Anzeige (<math>\blacktriangleright</math>)<br/>Vorspultaste (<math>\blacktriangleright\blacktriangleright</math>)<br/>Aufnahmetaste und Anzeige (<math>\bullet</math> REC)<br/>Pausentaste und Anzeige (<math>\blacksquare</math> PAUSE)<br/>Aufnahmeausspartaste (<math>\circ</math> REC MUTE)</p> | <p><b>8</b> Vormagnetisierungsstrom-Einstellregler (BIAS)</p> <p><b>9</b> Kopfhörerbuchse (PHONES)</p> <p><b>10</b> Kopfhörerpegelregler (PHONES LEVEL)</p> <p><b>11</b> Aufnahmepegelregler (REC LEVEL)</p> <p><b>12</b> Multi-Filternschalter (MPX FILTER)</p> <p><b>13</b> Dolby-Rauschverminderungsschalter (DOLBY NR)</p> <p><b>14</b> Linearzähler (LINEAR COUNTER) und Programm-Spitzenpegelmeter (PEAK PROGRAM METER)</p> |
|--|---|

## SECTION 2 MECHANICAL ADJUSTMENTS

### PRECAUTION

1. Clean the following parts with a denatured-alcohol-moistened swab:
 

record/playback head	pinch roller
erase head	rubber belts
capstan	idlers
2. Demagnetize the record/playback head with a head demagnetizer. (Do not bring the head demagnetizer close to the erase head.)
3. Do not use a magnetized screwdriver for the adjustments.
4. After the adjustments, apply suitable locking compound to the parts adjusted.
5. The adjustments should be performed with the rated power supply voltage unless otherwise noted.

### Torque Measurement

Torque	Torque meter	Meter reading
Forward	CQ-102C	30—70g·cm (0.42—0.97oz·inch)
Forward back tension	CQ-102C	2—6g·cm (0.028—0.083oz·inch)
FF/REW	CQ-201B	90—180g·cm (1.25—2.5oz·inch)

## SECTION 3 ELECTRICAL ADJUSTMENTS

1. The adjustment should be performed in the publication (Be sure to make playback adjustment at first.)
2. The adjustment and measurement should be performed for both L-CH and R-CH.
  - Switch position  
DOLBY NR switch: OFF  
TIMER switch: OFF
  - Standard record position  
Deliver the standard input signal level to the input jack and set the REC LEVEL control to obtain the standard output signal level as follows.

—Record mode—

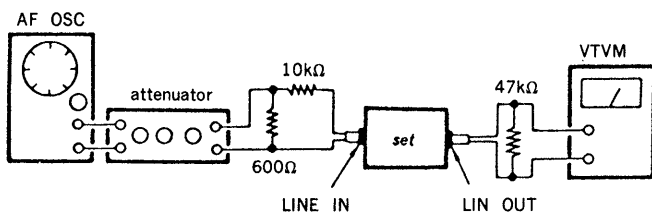

#### • Standard Input Level

Input terminal	LINE IN
source impedance	10kΩ
input signal level	0.25V (−10dB)

#### • Standard Output Level

Output terminal	LINE OUT
load impedance	47kΩ
output signal level	0.44V (−5dB)

### Test Tape

Tape	Contents	Use
P-4-A100	10kHz, −10dB	Record/Playback Head Azimuth Adjustment
WS-48B	3kHz, 0dB	Tape Speed Adjustment
P-4-L300	315Hz, 0dB	Playback Level Adjustment

### Record/Playback Head Azimuth Adjustment procedure :

1. Playback Mode

test tape  
P-4-A100  
(10kHz, −10dB)

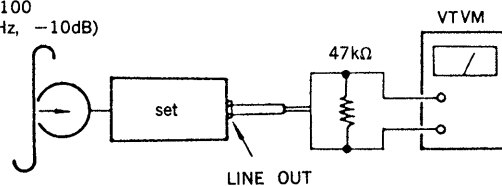

2. Turn the adjustment screw for the maximum output levels. If these levels do not match, turn the adjustment screw until both of output levels match together within 1dB.

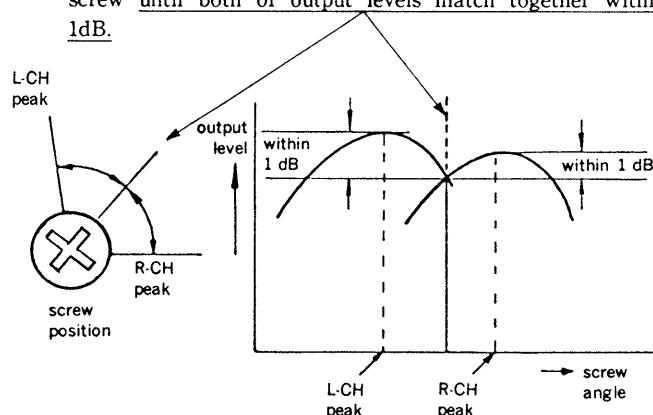

3. Phase Check

Playback mode

test tape  
P-4-A100  
(10kHz, -10dB)

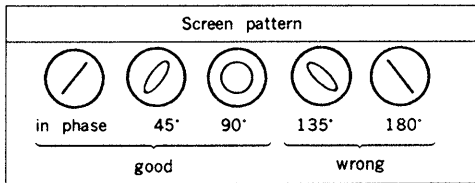
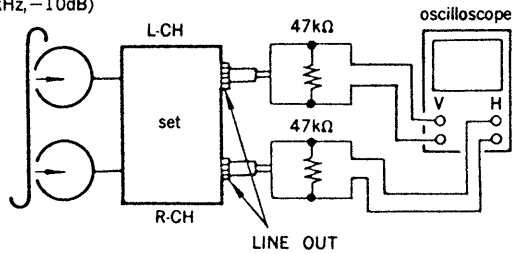

4. After the adjustment, lock the adjustment screw with suitable locking compound.

Adjustment Location: -record/playback head-

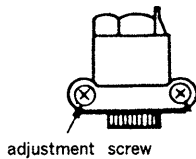

Playback Level Adjustment

Procedure:

Playback mode

test tape  
P-4-L300  
(315Hz, 0dB)

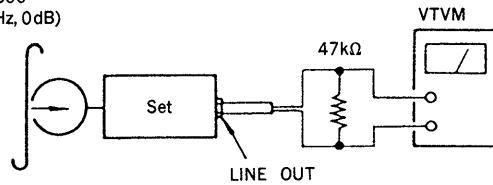

Specification:

Adjust RV101, 201 so that within adjustment level as follows.

LINE OUT level: 0.41 to 0.46V

(-5.5 to -4.5dB)

Level Difference between Channels: Within 0.5dB

Confirm the LINE OUT level does not change in playback mode while changing the mode from playback to stop several times.

Bias Consumption Current Adjustment

Bias Consumption current adjustment is sure to front of record bias adjustment.

Behind the bias consumption current adjustment, record bias adjustment do over again.

1. Connect CN514 with digital volt meter,
2. Adjust T151, 251 so that the minimum or digital volt meter.

Tape Speed Adjustment

Procedure:

Playback Mode

test tape  
WS-48B  
(3kHz, 0dB)

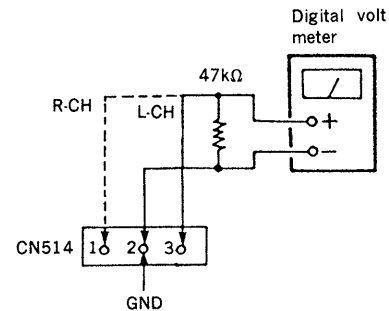
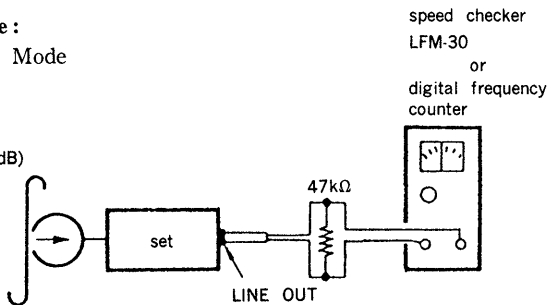

Specification:

Speed checker	Digital frequency counter
±0.5%	2,985-3,015Hz

Frequency difference between the beginning and the end of the tape should be within 0.5% (15Hz).

Adjustment Location:

adjustment the adjustable resistor of built in motor (adjustment by the insert to driver Speed in fastest that turn the clockwise.)

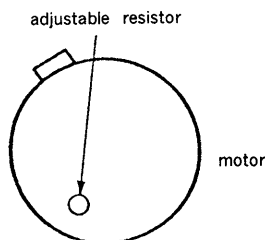

**Record Bias Adjustrent**

**Setting :**

REC LEVEL knob shall be the specied record position.

**Procedure :**

1. Record Mode

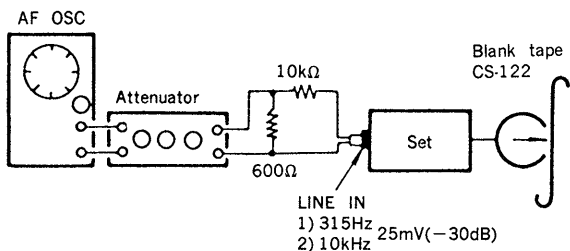

2. Playback Mode

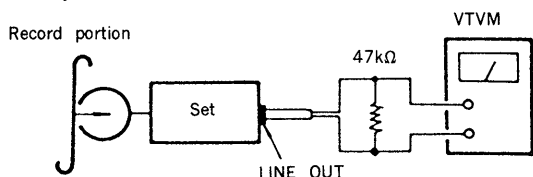

Adjust RV152, 252 so that playback output of 10kHz is  $0 \pm 0.5$ dB.

**Record Level Adjustment**

**Setting :**

REC LEVEL knob shall be at the specified record position.

**Procedure :**

1. Record Mode

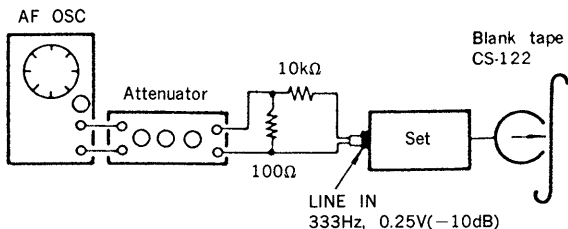

2. Playback Mode

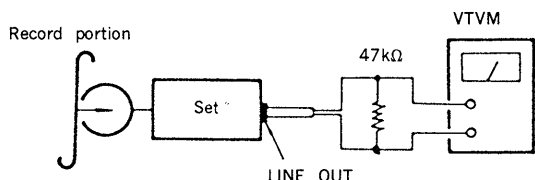

**Specification :**

Adjust RV151, 251 so that within adjustment level as follows.

LINE OUT Level: CS-122

0.41 to 0.46V  
(-5.5 to -4.5dB)

**Adjustment Location : main board**

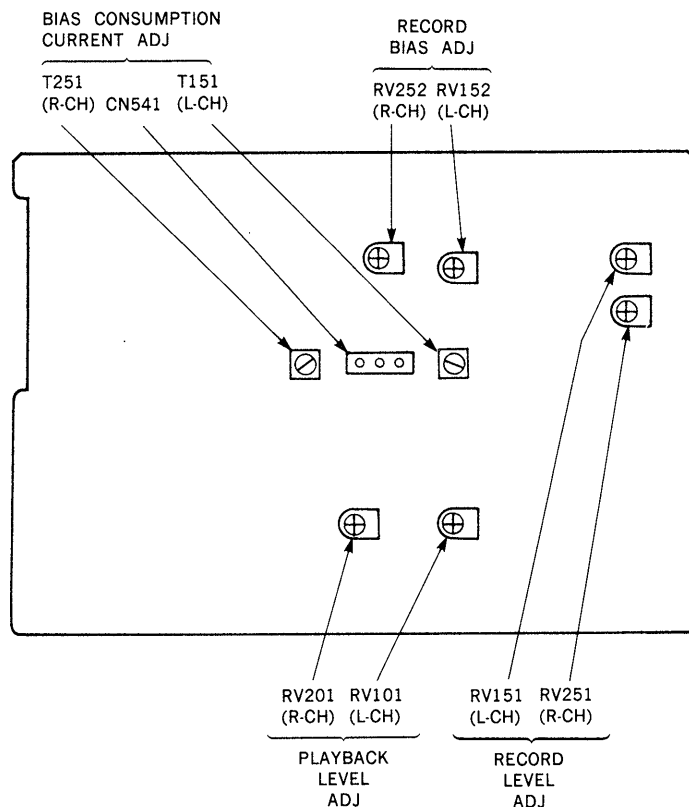

# SECTION 4 DIAGRAMS

## 4-1. SEMICONDUCTOR LEAD LAYOUTS

**CXA1198AP  
CX10034  
TC4019BP**

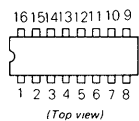

**μPC1297CA**

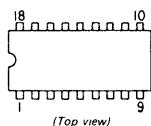

**2SB548  
2SD414  
2SD809-K**

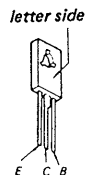

**HZ11B2L  
US1060M  
1SS132  
10E2**

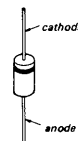

**CX20187  
LC6520C-3901**

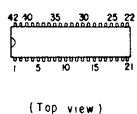

**DTA114ES  
DTB114ES  
DTC114ES  
DTC143TS  
DTC144ES  
2SC634SP**



**2SD774-3**



**GL-5HY41**

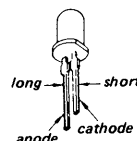

**TC4069UBP**

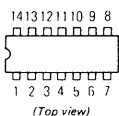

**2SA952  
2SB874A-C**



**2SD1585-L**

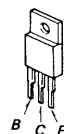

**SEL1210S  
SEL1410E**



**M5218P  
NJM2903D  
TC4071BP  
μPC4570C-1**

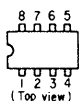

**2SA1150  
2SA1175  
2SC2785**

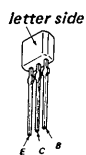

**2SK246-GR2**

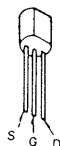

**SEL2410E-C**

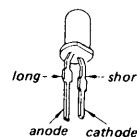

**HD614042SA87**

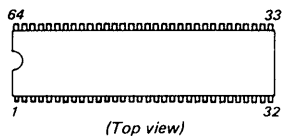

**2SA1409-L  
2SB1013  
2SC2001  
2SC3623-L  
2SD1387**

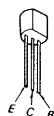

**HZS6A1L  
HZS7B 2 L  
HZS7C1L  
HZS12C1L**

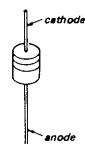

4-2. PRINTED WIRING BOARDS

• See page 6 for semiconductor lead layouts.

• Semiconductor Location

Ref. No.	Location	Ref. No.	Location
D301	C-19	Q201	H-24
D351	F-14	Q251	I-21
D401	B-19	Q252	D-19
D451	F-14	Q301	F-19
D511	G-22	Q401	H-18
D512	D-22	Q511	E-22
D-513	D-22	Q512	E-22
D-514	B-24	Q513	E-22
D515	D-22	Q514	D-20
D516	D-22	Q515	C-23
D517	D-22	Q516	C-23
D518	F-24	Q517	C-23
D701	B-28	Q518	B-24
D703	C-29	Q519	B-23
D704	C-29	Q520	B-23
D705	C-30	Q531	F-24
D706	C-29	Q532	G-22
D708	C-25	Q651	E-27
D709	C-25	Q652	E-27
D710	A-30	Q653	E-26
D711	B-28	Q654	F-26
D712	B-28	Q701	C-29
D713	B-28	Q702	D-30
D714	C-28	Q703	B-29
D715	B-27	Q704	C-29
D716	B-26	Q705	A-30
D717	B-26	Q706	A-30
D718	B-26	Q707	B-27
D719	D-29	Q708	C-28
D720	F-27	Q709	C-29
D751	B-21	Q710	D-30
D752	A-25	Q711	F-26
D753	A-25	Q712	B-25
D754	B-25	Q751	B-21
D755	B-25	Q752	A-21
D801	F-29	Q753	A-21
D803	F-28	Q754	B-22
D804	F-28	Q755	B-21
D805	D-29	Q756	B-21
D806	D-29	Q757	C-21
D807	I-28	Q758	C-22
D808	I-28	Q801	F-28
D901	E-9	Q802	F-28
D902	E-11	Q804	H-28
D903	E-10	Q805	H-28
D904	F-10	Q806	H-28
D905	F-11	Q807	I-28
D906	E-12	Q808	I-28
D907	E-12	Q809	I-27
		Q810	I-28
		Q811	I-28
IC501	G-23	Q812	I-29
IC511	G-20	Q813	I-22
IC512	E-19	Q814	D-28
IC513	D-23	Q901	G-7
IC552	C-19	Q902	G-7
IC553	G-16	Q903	G-7
IC651	E-27	Q904	G-7
IC801	G-27	Q905	G-8
IC802	H-26	Q906	G-8
IC803	H-29	Q907	G-13
IC804	G-29	Q908	G-11
IC901	F-8	Q909	E-12
IC902	F-13	Q910	E-11
IC903	F-11	Q1001	B-2
		Q1002	B-5
Q101	H-23		
Q151	F-21		
Q152	F-20		

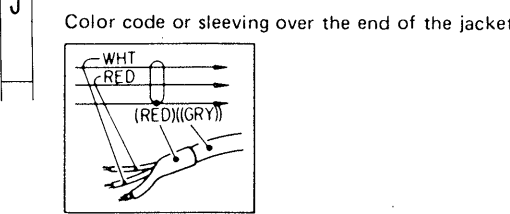

- : parts extracted from the component side.
- : indicates side identified with part number.

TC-K500 TC-K500

TC-K500 TC-K500

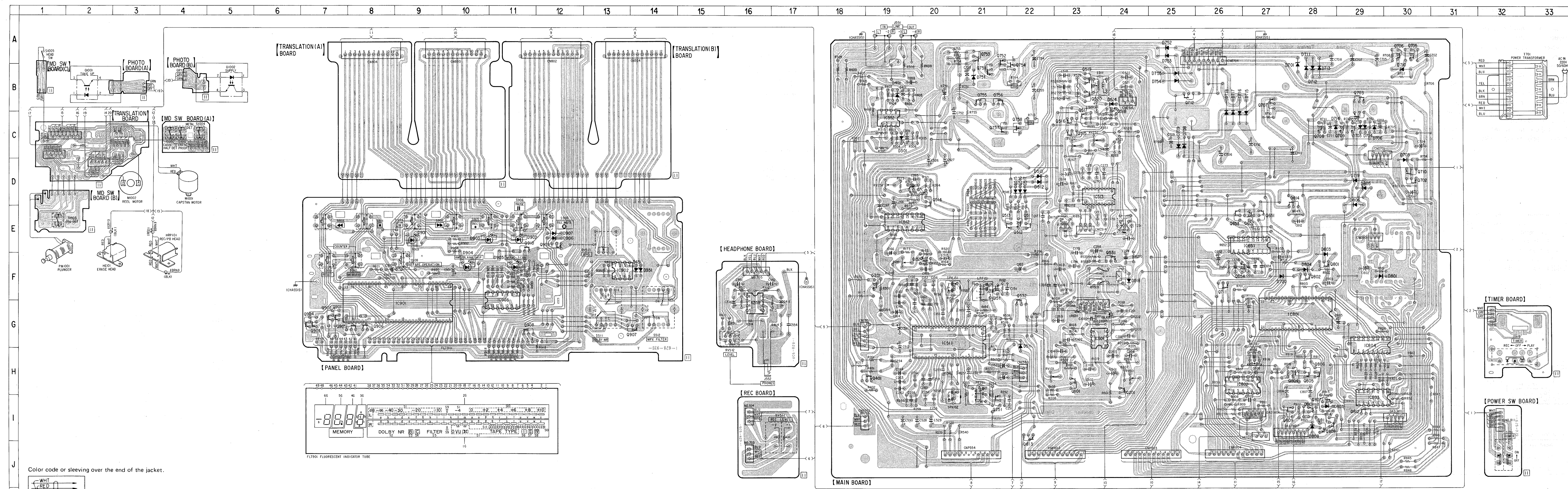

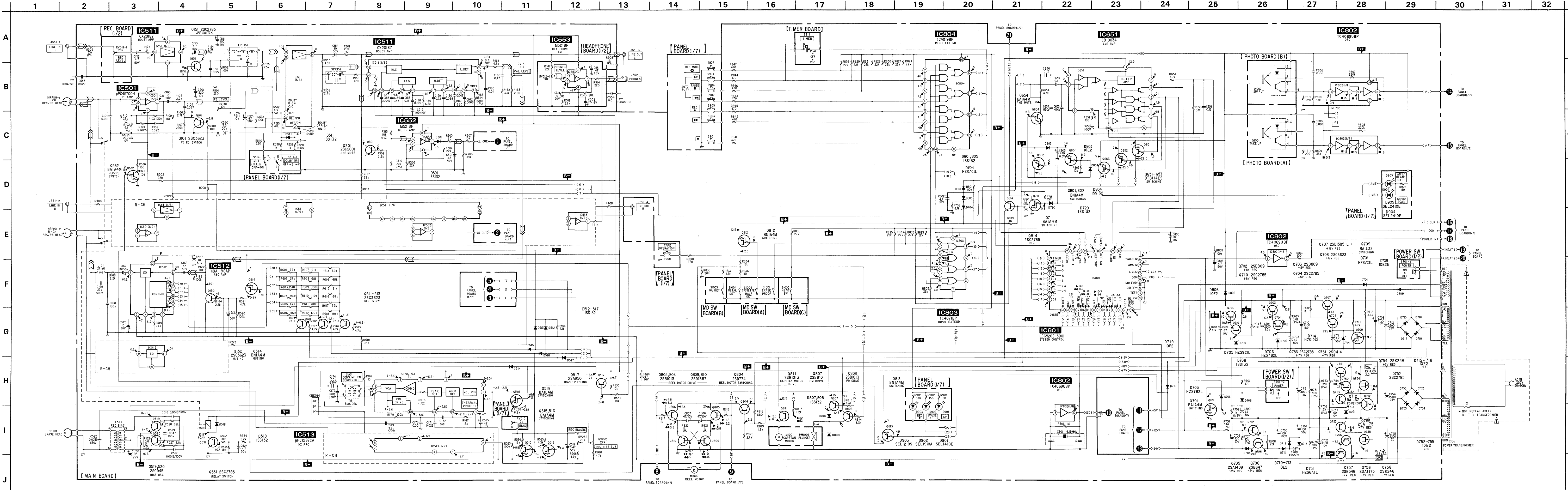

Note: Audio/System Control Section

- All capacitors are in  $\mu\text{F}$  unless otherwise noted.  $\text{pF} = \mu\text{F}$  50WV or less are not indicated except for electrolytics and tantalums.
- All resistors are in  $\Omega$  and  $1/4\text{W}$  or less unless otherwise specified.
- % : indicates tolerance.
- Components for right channel have same values as for left channel. Reference numbers are coded from C200 and C400.
- $\Delta$  : internal component.
- $\square$  : nonflammable resistor.
- $\text{---|}$  : fusible resistor.
- Switch

Ref. No.	Switch	Position
S511-1	DOLBY NR	OFF
S512-1	MPX FILTER	OFF
S701	POWER	OFF
S901	■	OFF
S902	▶▶	OFF
S903	◀◀	OFF
S904	▷	OFF
S905	△	OFF
S906	PAUSE II	OFF
S907	REC MUTE ○	OFF
S908	TAPE OPERATION	OFF
S911	TIMER	OFF

- $\square$  : adjustment for repair.
- Voltage and waveforms are dc with respect to ground under no-signal conditions.
- no mark : PLAY ◀◀ : REW ( ) : REC ■ : STOP
- ▶ : FWD ▶▶ : FF
- Voltages are taken with a VOM (50 k $\Omega$ /V).
- Voltage variations may be noted due to normal production tolerances.
- Signal path
- ▷ : PB
- ◁ : REC

Note: Display Section

- All capacitors are in  $\mu\text{F}$  unless otherwise noted.  $\text{pF} = \mu\text{F}$  50WV or less are not indicated except for electrolytics and tantalums.
- All resistors are in  $\Omega$  and  $1/4\text{W}$  or less unless otherwise specified.
- % : indicates tolerance.
- Voltage and waveforms are dc with respect to ground under no-signal conditions.
- no mark : PLAY
- Voltage variations may be noted due to normal production tolerances.
- Switch

Ref. No.	Switch	Position
S511-2	DOLBY NR	OFF
S512-2	MPX FILTER	OFF
S909	COUNTER RESET	OFF
S910	COUNTER MEMORY	OFF

Note: The components identified by mark  $\Delta$  or dotted line with mark  $\Delta$  are critical for safety. Replace only with part number specified.



4-4. SCHEMATIC DIAGRAM — DISPLAY SECTION—

• See page 15 for notes for Display Section

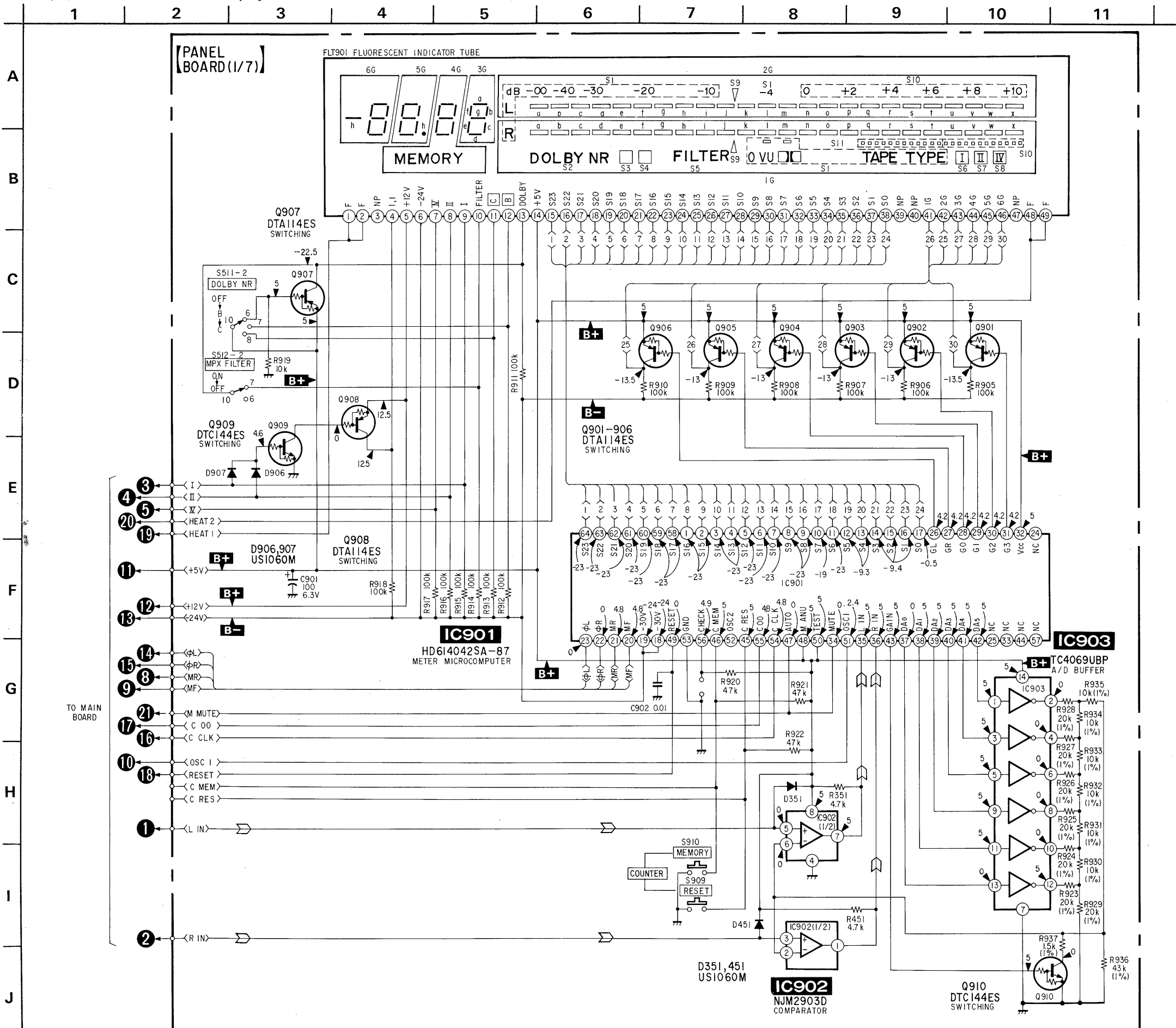

## SECTION 5 EXPLODED VIEWS

**NOTE:**

- The mechanical parts with no reference number in the exploded views are not supplied.
- The construction parts of an assembled part are indicated with a collation number in the remark column.
- Items marked “\*” are not stocked since they are seldom required for routine service. Some delay should be anticipated when ordering these items.

- Due to standardization, parts with part number suffix -XX and -X may be different from the parts specified in the components used on the set.
- Color Indication of Appearance Parts  
Example:  
(RED) ... KNOB, BALANCE (WHITE)  
↑ Cabinet's Color                      ↑ Parts Color

The components identified by mark or dotted line with mark are critical for safety. Replace only with part number specified.

### 5-1. CABINET SECTION

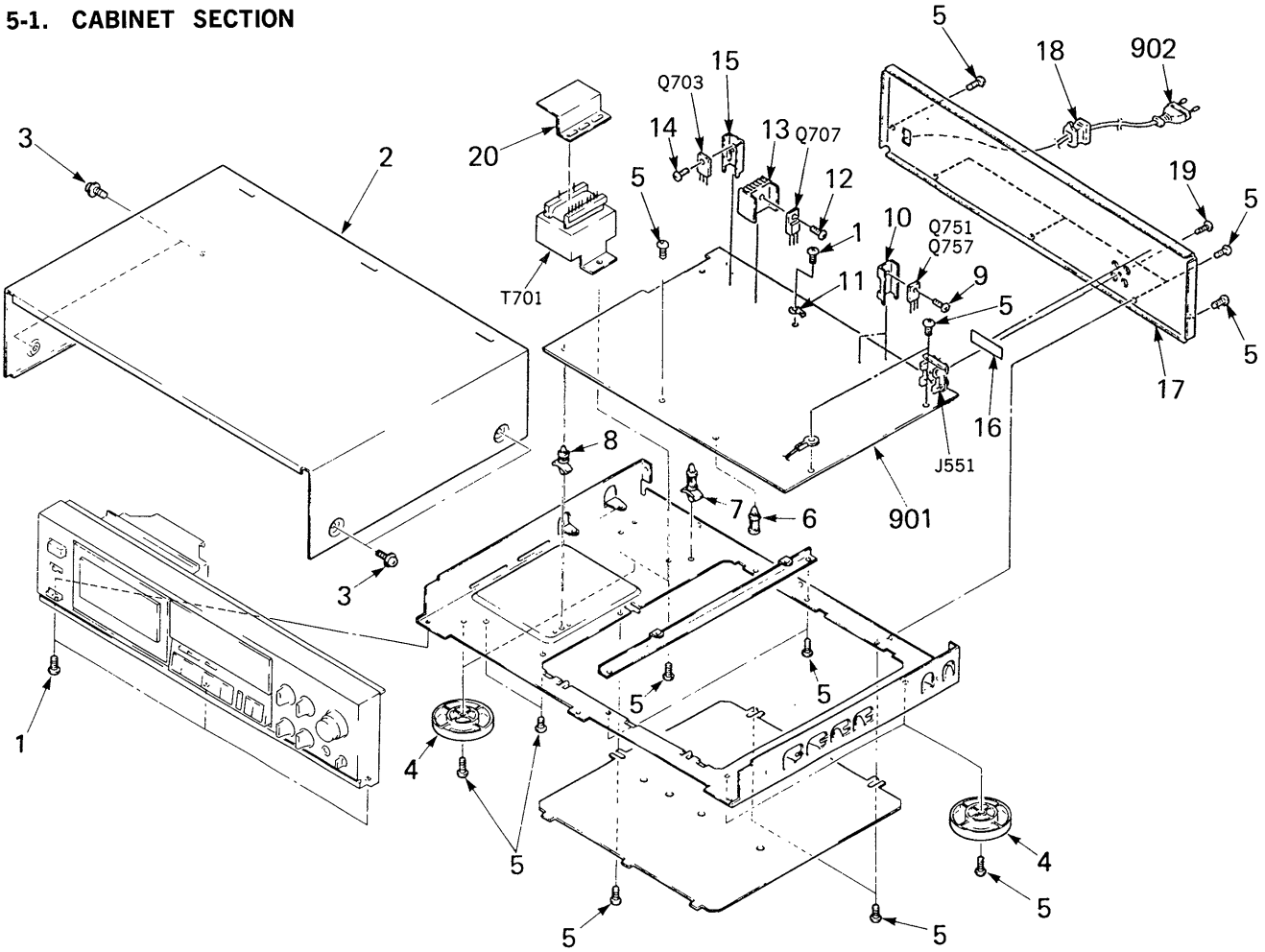

No.	Part No.	Description	Remarks	No.	Part No.	Description	Remarks
1	3-703-685-21	SCREW (+BV 3X8)		13	*4-363-146-21	HEAT SINK, V.OUT	
2	3-350-407-01	CASE		14	7-682-147-01	SCREW +BVTT 3X6 (S)	
3	3-704-366-01	SCREW (CASE) (M3X8)		15	*4-861-002-00	HEAT SINK	
4	X-4885-935-1	FOOT ASSY		16	*3-701-030-00	LABEL, SERIAL NUMBER	
5	7-682-548-04	SCREW +BVTT 3X8 (S)		17	*3-318-692-01	PANEL, BACK	
6	*3-669-610-00	SPACER		18	*3-703-244-00	BUSHING (2104), CORD	
7	*3-346-265-11	HOLDER, PC BOARD		19	7-621-849-00	SCREW, TAPPING	
8	*4-924-098-11	HOLDER, PC BOARD		20	*3-337-136-01	COVER, TRANSFORMER SAFETY	
9	7-682-147-15	SCREW, TR		901	*A-2056-435-A	MOUNTED PCB, MAIN	
10	*4-861-002-00	HEAT SINK		902	1-555-795-00	CORD, POWER, EULO PLUG	
11	4-870-539-00	PLATE, GROUND		J551	1-565-258-21	JACK, PIN 4P (LINE IN/OUT)	
12	7-685-646-79	SCREW +BVTP 3X8 TYPE2 IT-3		T701	1-449-468-11	TRANSFORMER, POWER	

5-2. FRONT PANEL SECTION

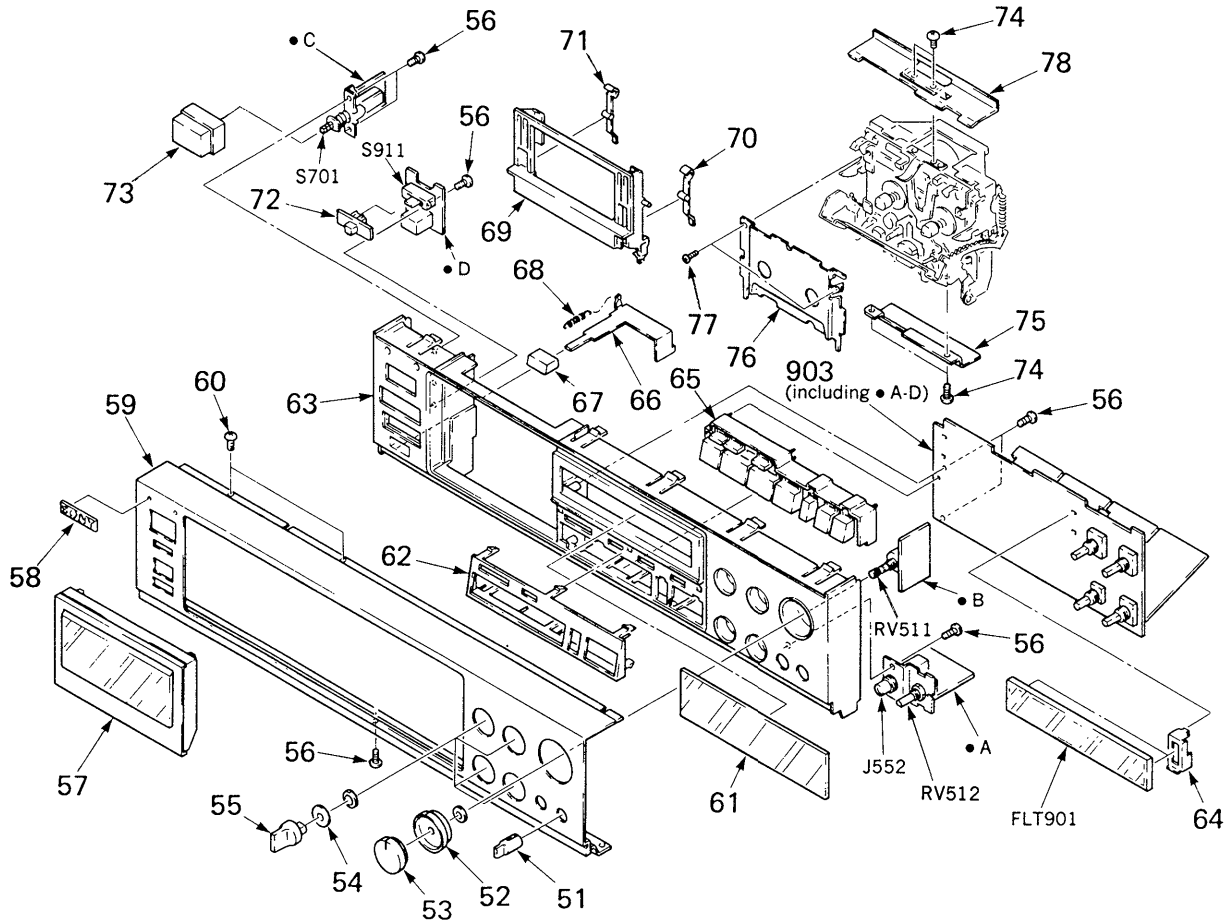

No.	Part No.	Description	Remarks	No.	Part No.	Description	Remarks
51	4-921-921-11	KNOB (M)		69	X-3332-448-1	HOLDER ASSY, CASSETTE	
52	3-332-589-01	KNOB (REC VOL-LEFT)		70	3-307-372-00	SPRING (RIGHT)	
53	3-332-590-01	KNOB (REC VOL-RIGHT)		71	3-307-371-00	SPRING (LEFT)	
54	3-350-416-01	SPACER		72	3-307-538-21	KNOB, SWITCH, TIMER	
55	4-908-097-21	KNOB		73	4-917-460-01	KNOB, POWER	
56	7-685-534-19	SCREW +BTP 2.6X8 TYPE2 N-S		74	7-682-147-01	SCREW +BVTT 3X6 (S)	
57	A-2169-139-A	LID ASSY, CASSETTE		75	*3-332-560-01	BRACKET (MDB)	
58	4-925-334-01	EMBLEM (5-A), SONY		76	*3-332-547-01	PLATE, ORNAMENTAL	
59	3-350-404-21	PANEL, FRONT		77	7-621-772-00	SCREW +B 2X3	
60	7-685-873-01	SCREW +BVTT 3X8		78	*3-332-561-01	BRACKET (MDU)	
61	3-318-698-01	WINDOW (M)		903	*A-2056-438-A	MOUNTED PCB, PANEL	
62	X-3304-941-1	PLATE (B) ASSY, ORNAMENTAL		FLT901	1-519-491-11	INDICATOR TUBE, FLUORESCENT	
63	3-350-405-11	PANEL (BASE)		J552	1-507-796-71	JACK (LARGE TYPE) (PHONES)	
64	*3-318-695-01	HOLDER (FL)		RV511	1-238-097-11	RES, VAR, CARBON 20K/20K (REC LEVEL)	
65	X-3304-939-1	BUTTON ASSY		RV512	1-238-085-11	RES, VAR, CARBON 20K/20K (PHONES LEVEL)	
66	*3-332-564-01	SLIDER (EJC)		S701	1-570-103-21	SWITCH, PUSH (1 KEY)(POWER)	
67	3-343-698-11	BUTTON (EJECT)		S911	1-554-208-00	SWITCH, SLIDE (TIMER)	
68	3-571-829-00	SPRING, TENSION					

5-3. MECHANISM SECTION ①  
(TCM-CMAY B-26)

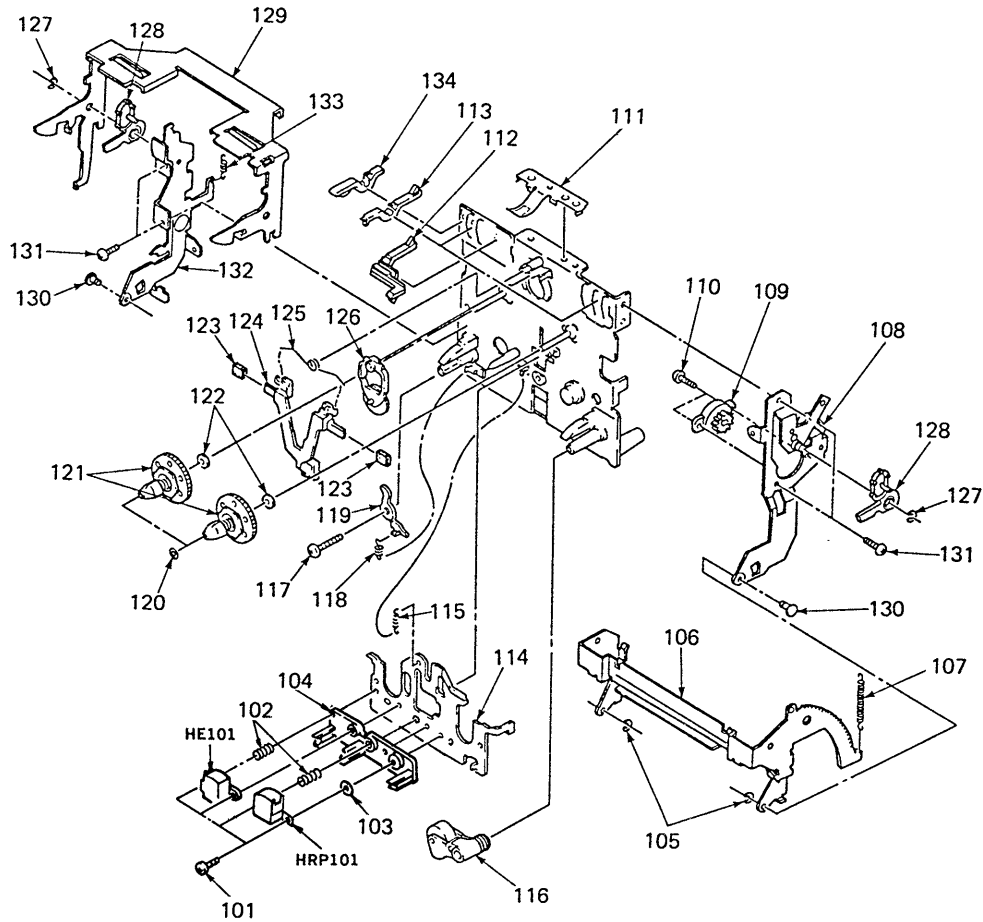

Ref.No	Part No.	Description	Remarks	Ref.No	Part No.	Description	Remarks
101	7-621-255-75	SCREW,TOTSU PWH 2X12		119	3-391-121-01	ARM (B), EJECT SAFETY	
102	3-391-101-01	SPRING		120	3-701-436-11	WASHER, 1.6 POLYETHYLENE	
103	3-701-437-01	WASHER		121	X-3391-107-1	REEL ASSY, T.U	
104	*3-391-104-01	SPACER, HEAD		122	3-392-711-01	WASHER (2.1X0.25) (T)	
105	7-624-102-04	STOP RING 1.5, TYPE -E		123	3-392-728-01	RUBBER, BRAKE	
106	*3-391-182-01	HOLDER, CASSETTE		124	3-392-723-01	LEVER (B), HOLD	
107	3-391-184-01	SPRING		125	3-391-124-01	SPRING	
108	*3-392-722-01	PLATE HOLD BLK		126	X-3391-111-1	IDLER ASSY	
109	X-3391-151-1	DAMPER ASSY		127	7-624-105-04	STOP RING 2.3, TYPE -E	
110	7-621-255-15	SCREW +PTT 2X3 (S)		128	3-391-185-01	LEVER, STOP	
111	3-391-177-01	SPRING		129	*3-391-180-01	ARM, EJECT	
112	3-392-726-01	LEVER		130	3-391-183-01	SHAFT (B), HOLDER FULCRUM	
113	3-392-724-01	LEVER		131	7-621-773-86	SCREW +PTT 2.6X4 (S)	
114	*3-392-708-01	BASE, HEAD		132	*X-3391-152-1	ARM ASSY, EJECT	
115	3-391-114-01	SPRING		133	3-391-181-01	SP, LEVER RETURN	
116	3-392-731-01	PINCH ROLLER (R) ASSY		134	3-392-725-01	LEVER	
117	3-392-733-01	SCREW		HE101		HEAD, ERASE	
118	3-391-122-01	SPRING (A)		HRP101	1-543-594-11	HEAD, MAGNETIC (REC/PB)	

**5-4. MECHANISM SECTION ②**  
**(TCM-CMAY B-26)**

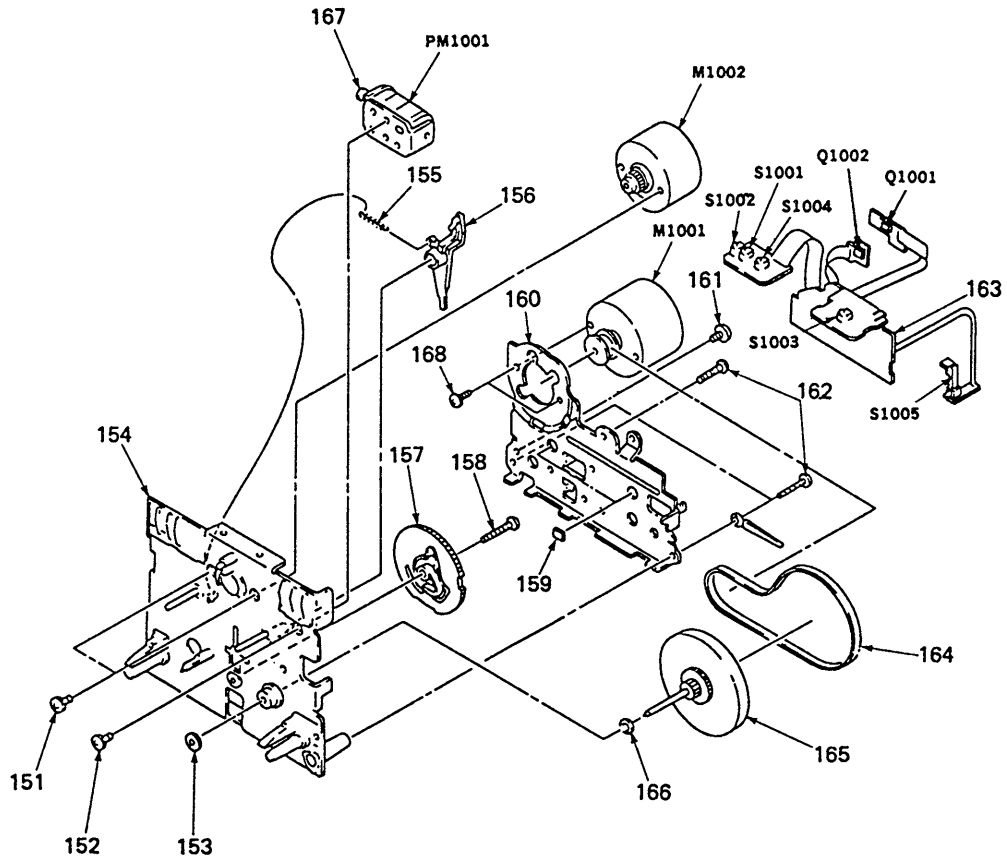

Ref.No	Part No.	Description	Remarks	Ref.No	Part No.	Description	Remarks
151	7-621-770-67	SCREW + P 2.6X6		165	X-3391-145-1	ASSY F/W	
152	7-621-759-25	+PSW, 2.6X4		166	3-701-438-11	WASHER, 2.5	
153	3-391-119-01	SEAL, WASHER OIL		167	*3-392-707-01	SOLENOID (ARBOR)	
154	3-392-710-01	CHASSIS BASE BLK		168	7-628-253-90	SCREW + PS 2.6X4	
155	3-392-730-01	SP, PLAY ARM		M1001	X-3391-130-1	MOTOR ASSY	
156	3-392-727-01	ARM, PLAY		M1002	3-392-709-01	MTR REEL BLK	
157	3-391-197-01	GEAR (I), CAM		PM1001	1-454-440-11	SOLENOID, PLUNGER	
158	3-392-732-01	SCREW (2X15), TT, WASHER		Q1001	1-807-509-11	PHOTO SENSOR	
159	3-391-129-01	SPACER		Q1002	1-807-509-11	PHOTO SENSOR	
160	*3-392-720-01	F/W BKT		S1001	1-571-081-11	SWITCH	
161	7-682-546-04	SCREW +PTT 3X5 (S)		S1002	1-571-081-11	SWITCH	
162	7-685-131-19	SCREW +P 2.6X4 TYPE2 NON-SLIT		S1003	1-571-081-11	SWITCH	
163	*3-392-721-01	PCB CONTROL BLK		S1004	1-571-081-11	SWITCH	
164	3-392-729-01	BELT, MAIN		S1005	1-571-820-11	SWITCH, LEAF	

## SECTION 6 ELECTRICAL PARTS LIST

**NOTE:**

- Due to standardization, replacements in the parts list may be different from the parts specified in the diagrams or the components used on the set.
- Items marked "\*" are not stocked since they are seldom required for routine service. Some delay should be anticipated when ordering these items.
- If there are two or more same circuits in a set such as a stereophonic machine, only typical circuit parts may be indicated and capacitors and resistors in other same circuits may be omitted.

**CAPACITORS:**  
MF:  $\mu$ F, PF:  $\mu$ PF.

**RESISTORS**  
• All resistors are in ohms.  
• F: nonflammable

**COILS**  
• MMH: mH, UH:  $\mu$ H

**SEMICONDUCTORS**  
In each case, U:  $\mu$ , for example:  
UA....:  $\mu$ A...., UPA....:  $\mu$ PA....,  
UPC....:  $\mu$ PC, UPD....:  $\mu$ PD...

The components identified by mark  $\Delta$  or dotted line with mark  $\Delta$  are critical for safety. Replace only with part number specified.

Ref.No.	Part No.	Description				Ref.No.	Part No.	Description			
901	*A-2056-435-A	MOUNTED PCB, MAIN				C520	1-126-233-11	ELECT	22MF	20%	25V
902	$\Delta$ 1-555-795-00	CORD, POWER, EULO PLUG				C521	1-107-045-00	MICA	3.9PF	0.5PF	500V
903	*A-2056-438-A	MOUNTED PCB, PANEL				C522	1-136-558-11	FILM	0.0039MF	5%	630V
C101	1-106-343-00	MYLAR	0.001MF	5%	50V	C524	1-124-927-11	ELECT	4.7MF	20%	50V
C102	1-130-487-00	MYLAR	0.022MF	5%	50V	C525	1-124-927-11	ELECT	4.7MF	20%	50V
C103	1-124-657-00	ELECT	10MF	20%	50V	C526	1-123-875-11	ELECT	10MF	20%	50V
C104	1-130-488-00	MYLAR	0.027MF	5%	50V	C527	1-123-875-11	ELECT	10MF	20%	50V
C151	1-106-353-00	MYLAR	0.0027MF	5%	50V	C528	1-124-499-11	ELECT	1MF	20%	50V
C152	1-124-927-11	ELECT	4.7MF	20%	50V	C529	1-124-499-11	ELECT	1MF	20%	50V
C153	1-124-927-11	ELECT	4.7MF	20%	50V	C530	1-123-382-00	ELECT	3.3MF	20%	50V
C154	1-124-657-00	ELECT	10MF	20%	50V	C551	1-124-477-11	ELECT	47MF	20%	16V
C155	1-106-359-00	MYLAR	0.0047MF	5%	50V	C552	1-124-477-11	ELECT	47MF	20%	16V
C156	1-136-173-00	FILM	0.47MF	5%	50V	C553	1-130-487-00	MYLAR	0.022MF	5%	50V
C157	1-136-167-00	FILM	0.15MF	5%	50V	C554	1-161-379-00	CERAMIC	0.01MF	30%	25V
C158	1-136-155-00	FILM	0.015MF	5%	50V	C651	1-136-166-00	FILM	0.12MF	5%	50V
C159	1-136-169-00	FILM	0.22MF	5%	50V	C652	1-124-499-11	ELECT	1MF	20%	50V
C160	1-136-163-00	FILM	0.068MF	5%	50V	C653	1-162-290-31	CERAMIC	470PF	10%	50V
C161	1-136-161-00	FILM	0.047MF	5%	50V	C654	1-162-293-31	CERAMIC	820PF	10%	50V
C162	1-130-481-00	MYLAR	0.0068MF	5%	50V	C655	1-136-165-00	FILM	0.1MF	5%	50V
C163	1-136-153-00	FILM	0.01MF	5%	50V	C656	1-136-166-00	FILM	0.12MF	5%	50V
C164	1-124-927-11	ELECT	4.7MF	20%	50V	C701	1-124-446-11	ELECT	47MF	20%	10V
C165	1-136-173-00	FILM	0.47MF	5%	50V	C702	1-124-122-11	ELECT	100MF	20%	35V
C166	1-123-382-00	ELECT	3.3MF	20%	50V	C703	1-124-927-11	ELECT	4.7MF	20%	50V
C167	1-123-875-11	ELECT	10MF	20%	50V	C704	1-124-893-11	ELECT	2200MF	20%	6.3V
C168	1-162-285-31	CERAMIC	180PF	10%	50V	C705	1-123-605-00	ELECT	100MF	20%	100V
C169	1-107-210-00	MICA	22PF	5%	500V	C706	1-124-898-11	ELECT	4700MF	20%	16V
C170	1-136-165-00	FILM	0.1MF	5%	50V	C707	1-124-122-11	ELECT	100MF	20%	50V
C171	1-136-157-00	FILM	0.022MF	5%	50V	C708	1-124-122-11	ELECT	100MF	20%	50V
C172	1-136-153-00	FILM	0.01MF	5%	50V	C709	1-124-927-11	ELECT	4.7MF	20%	50V
C173	1-130-471-00	MYLAR	0.001MF	5%	50V	C710	1-124-887-00	ELECT	3300MF	20%	16V
C174	1-136-433-11	FILM	100PF	5%	630V	C711	1-124-927-11	ELECT	4.7MF	20%	50V
C175	1-136-435-11	FILM	150PF	5%	630V	C712	1-124-618-11	ELECT	2200MF	20%	35V
C301	1-123-382-00	ELECT	3.3MF	20%	50V	C751	1-124-473-11	ELECT	1000MF	20%	10V
C311	1-123-875-11	ELECT	10MF	20%	50V	C752	1-124-473-11	ELECT	1000MF	20%	10V
C501	1-126-176-11	ELECT	220MF	20%	10V	C753	1-124-443-00	ELECT	100MF	20%	10V
C502	1-126-176-11	ELECT	220MF	20%	10V	C754	1-124-563-11	ELECT	2200MF	20%	25V
C511	1-124-443-00	ELECT	100MF	20%	10V	C755	1-124-563-11	ELECT	2200MF	20%	25V
C512	1-124-443-00	ELECT	100MF	20%	10V	C802	1-124-927-11	ELECT	4.7MF	20%	50V
C513	1-124-499-11	ELECT	1MF	20%	50V	C803	1-124-472-11	ELECT	470MF	20%	6.3V
C514	1-124-477-11	ELECT	47MF	20%	16V	C804	1-124-927-11	ELECT	4.7MF	20%	50V
C515	1-124-446-11	ELECT	47MF	20%	10V	C805	1-124-443-00	ELECT	100MF	20%	10V
C516	1-124-902-00	ELECT	0.47MF	20%	50V	C806	1-124-446-11	ELECT	47MF	20%	10V
C517	1-136-253-11	FILM	0.0018MF	5%	100V	C807	1-124-446-11	ELECT	47MF	20%	10V
C518	1-136-253-11	FILM	0.0018MF	5%	100V	C808	1-162-294-31	CERAMIC	0.001MF	10%	50V
C519	1-136-233-11	FILM	0.0047MF	5%	100V	C809	1-162-294-31	CERAMIC	0.001MF	10%	50V

Ref.No.	Part No.	Description				Ref.No.	Part No.	Description
C812	1-124-927-11	ELECT	4.7MF	20%	50V	D803	8-719-200-02	DIODE 10E2
C901	1-123-661-00	ELECT	100MF	20%	6.3V	D804	8-719-940-76	DIODE 1SS132
C902	1-161-379-00	CERAMIC	0.01MF	30%	16V	D805	8-719-940-76	DIODE 1SS132
CN554	*1-566-827-11	SOCKET, CONNECTOR	12P			D806	8-719-200-02	DIODE 10E2
CN802	*1-566-827-11	SOCKET, CONNECTOR	12P			D807	8-719-940-76	DIODE 1SS132
CN803	*1-566-827-11	SOCKET, CONNECTOR	12P			D808	8-719-940-76	DIODE 1SS132
CN804	*1-566-827-11	SOCKET, CONNECTOR	12P					
CND701	*1-564-339-00	PIN, CONNECTOR	5P			D901	8-719-305-52	DIODE SEL1410E
CND801	*1-564-337-00	PIN, CONNECTOR	3P			D902	8-719-941-46	DIODE GL-5HY41
						D903	8-719-302-45	DIODE SEL1210S
CNE501	*1-564-509-11	PLUG, CONNECTOR	6P			D904	8-719-301-43	DIODE SEL2410E-C
CNE514	*1-564-506-11	PLUG, CONNECTOR	3P			D905	8-719-301-43	DIODE SEL2410E-C
CNE516	*1-564-506-11	PLUG, CONNECTOR	3P			D906	8-719-000-26	DIODE US1060M
						D907	8-719-000-26	DIODE US1060M
CNE551	*1-564-508-11	PLUG, CONNECTOR	5P			FLT901	1-519-491-11	INDICATOR TUBE, FLUORESCENT
CNE552	*1-564-506-11	PLUG, CONNECTOR	3P			IC501	8-759-111-44	IC UPC4570C-1
CNE553	*1-564-506-11	PLUG, CONNECTOR	3P			IC511	8-752-018-70	IC CX20187
						IC512	8-752-033-61	IC CXA1198AP
CNE703	*1-564-506-11	PLUG, CONNECTOR	3P			IC513	8-759-106-56	IC UPC1297CA
CNE704	*1-564-512-11	PLUG, CONNECTOR	9P			IC552	8-759-601-02	IC M5218P
						IC553	8-759-601-02	IC M5218P
CNP554	*1-566-826-11	PLUG, CONNECTOR	12P			IC651	8-759-700-46	IC CX10034
CNP802	*1-566-826-11	PLUG, CONNECTOR	12P			IC801	8-759-821-29	IC LC6520C-3901
CNP803	*1-566-826-11	PLUG, CONNECTOR	12P			IC802	8-759-240-69	IC TC4069UBP
CNP804	*1-566-826-11	PLUG, CONNECTOR	12P			IC803	8-759-240-71	IC TC4071BP
						IC804	8-759-240-19	IC TC4019BP
D301	8-719-940-76	DIODE	1SS132			IC901	8-759-302-98	IC HD614042SA87
D351	8-719-000-26	DIODE	US1060M			IC902	8-759-729-03	IC NJM2903D
D401	8-719-940-76	DIODE	1SS132			IC903	8-759-240-69	IC TC4069UBP
D451	8-719-000-26	DIODE	US1060M			J551	1-565-258-21	JACK, PIN 4P(LINE IN/OUT)
D511	8-719-940-76	DIODE	1SS132			J552	1-507-796-71	JACK (LARGE TYPE) (PHONES)
D512	8-719-940-76	DIODE	1SS132			L151	1-410-780-11	INDUCTOR 27MMH
D513	8-719-940-76	DIODE	1SS132			L251	1-410-780-11	INDUCTOR 27MMH
D514	8-719-940-76	DIODE	1SS132			LPF151	1-236-147-11	FILTER, LOW PASS
D515	8-719-940-76	DIODE	1SS132			LPF251	1-236-147-11	FILTER, LOW PASS
D516	8-719-940-76	DIODE	1SS132			Q101	8-729-107-77	TRANSISTOR 2SC3623-L
D517	8-719-940-76	DIODE	1SS132			Q151	8-729-178-54	TRANSISTOR 2SC2785
D518	8-719-940-76	DIODE	1SS132			Q152	8-729-107-77	TRANSISTOR 2SC3623-L
D701	8-719-933-49	DIODE	HZS7C1L			Q201	8-729-107-77	TRANSISTOR 2SC3623-L
D703	8-719-933-47	DIODE	HZS7B2L			Q251	8-729-178-54	TRANSISTOR 2SC2785
D704	8-719-933-49	DIODE	HZS7C1L			Q252	8-729-107-77	TRANSISTOR 2SC3623-L
D705	8-719-910-15	DIODE	HZ11B2L			Q301	8-729-100-13	TRANSISTOR 2SC2001
D706	8-719-933-47	DIODE	HZS7B2L			Q401	8-729-100-13	TRANSISTOR 2SC2001
D708	8-719-940-76	DIODE	1SS132			Q511	8-729-107-77	TRANSISTOR 2SC3623-L
D709	8-719-200-02	DIODE	10E2			Q512	8-729-107-77	TRANSISTOR 2SC3623-L
D710	8-719-200-02	DIODE	10F2			Q513	8-729-107-77	TRANSISTOR 2SC3623-L
D711	8-719-200-02	DIODE	10E2			Q514	8-729-900-61	TRANSISTOR DTA114ES
D712	8-719-200-02	DIODE	10F2			Q515	8-729-900-80	TRANSISTOR DTC114ES
D713	8-719-200-02	DIODE	10E2			Q516	8-729-900-80	TRANSISTOR DTC114ES
D714	8-719-933-79	DIODE	HZS12C1L			Q517	8-729-195-23	TRANSISTOR 2SA952
D715	8-719-200-02	DIODE	10E2			Q518	8-729-900-89	TRANSISTOR DTC114ES
D716	8-719-200-02	DIODE	10E2			Q519	8-729-600-27	TRANSISTOR 2SC634SP
D717	8-719-200-02	DIODE	10E2			Q520	8-729-600-27	TRANSISTOR 2SC634SP
D718	8-719-200-02	DIODE	10F2			Q531	8-729-178-54	TRANSISTOR 2SC2785
D719	8-719-200-02	DIODE	10E2			Q532	8-729-900-80	TRANSISTOR DTC114ES
D720	8-719-940-76	DIODE	1SS132			Q651	8-729-920-26	TRANSISTOR DTB114ES
D751	8-719-933-33	DIODE	HZS6A1L					
D752	8-719-200-02	DIODE	10E2					
D753	8-719-200-02	DIODE	10E2					
D754	8-719-200-02	DIODE	10E2					
D755	8-719-200-02	DIODE	10E2					
D801	8-719-940-76	DIODE	1SS132					

Ref.No.	Part No.	Description			
Q652	8-729-920-26	TRANSISTOR DTB114ES			
Q653	8-729-920-26	TRANSISTOR DTB114ES			
Q654	8-729-900-80	TRANSISTOR DTC114ES			
Q701	8-729-900-80	TRANSISTOR DTC114ES			
Q702	8-729-180-92	TRANSISTOR 2SD809-K			
Q703	8-729-180-92	TRANSISTOR 2SD809-K			
Q704	8-729-178-54	TRANSISTOR 2SC2785			
Q705	8-729-110-68	TRANSISTOR 2SA1409-L			
Q706	8-729-300-72	TRANSISTOR 2SB874A-C			
Q707	8-729-107-25	TRANSISTOR 2SD1585-L			
Q708	8-729-107-77	TRANSISTOR 2SC3623-L			
Q709	8-729-900-74	TRANSISTOR DTC143TS			
Q710	8-729-178-54	TRANSISTOR 2SC2785			
Q711	8-729-900-80	TRANSISTOR DTC114ES			
Q712	8-729-900-74	TRANSISTOR DTC143TS			
Q751	8-729-141-43	TRANSISTOR 2SD414			
Q752	8-729-178-54	TRANSISTOR 2SC2785			
Q753	8-729-178-54	TRANSISTOR 2SC2785			
Q754	8-729-201-56	TRANSISTOR 2SK246-GR2			
Q755	8-729-117-54	TRANSISTOR 2SA1175			
Q756	8-729-117-54	TRANSISTOR 2SA1175			
Q757	8-729-154-88	TRANSISTOR 2SB548			
Q758	8-729-201-56	TRANSISTOR 2SK246-GR2			
Q801	8-729-900-61	TRANSISTOR DTA114ES			
Q802	8-729-900-61	TRANSISTOR DTA114ES			
Q804	8-729-177-42	TRANSISTOR 2SD774-3			
Q805	8-729-801-88	TRANSISTOR 2SB1013			
Q806	8-729-801-88	TRANSISTOR 2SB1013			
Q807	8-729-205-02	TRANSISTOR 2SA1150			
Q808	8-729-801-88	TRANSISTOR 2SB1013			
Q809	8-729-801-93	TRANSISTOR 2SD1387			
Q810	8-729-801-93	TRANSISTOR 2SD1387			
Q811	8-729-801-88	TRANSISTOR 2SB1013			
Q812	8-729-900-61	TRANSISTOR DTA114ES			
Q813	8-729-900-61	TRANSISTOR DTA114ES			
Q814	8-729-178-54	TRANSISTOR 2SC2785			
Q901	8-729-900-61	TRANSISTOR DTA114ES			
Q902	8-729-900-61	TRANSISTOR DTA114ES			
Q903	8-729-900-61	TRANSISTOR DTA114ES			
Q904	8-729-900-61	TRANSISTOR DTA114ES			
Q905	8-729-900-61	TRANSISTOR DTA114ES			
Q906	8-729-900-61	TRANSISTOR DTA114ES			
Q907	8-729-900-61	TRANSISTOR DTA114ES			
Q908	8-729-900-61	TRANSISTOR DTA114ES			
Q909	8-729-900-89	TRANSISTOR DTC144ES			
Q910	8-729-900-89	TRANSISTOR DTC144ES			
R101	1-214-761-00	METAL	22K	1%	1/4W
R102	1-214-700-11	METAL	62	1%	1/4W
R103	1-249-603-11	CARBON	130K	5%	1/4W
R104	1-249-940-11	CARBON	5.1K	1%	1/4W
R105	1-247-717-11	CARBON	2.2K	5%	1/4W
R106	1-247-718-11	CARBON	2.7K	5%	1/4W
R107	1-247-887-00	CARBON	220K	5%	1/4W
R108	1-249-429-11	CARBON	10K	5%	1/4W
R109	1-249-431-11	CARBON	15K	5%	1/4W
R117	1-249-433-11	CARBON	22K	5%	1/4W
R151	1-249-417-11	CARBON	1K	5%	1/4W
R152	1-249-441-11	CARBON	100K	5%	1/4W

Ref.No.	Part No.	Description			
R154	1-247-719-11	CARBON	3.3K	5%	1/4W
R155	1-247-152-00	CARBON	7.5K	5%	1/4W
R156	1-249-543-11	CARBON	430	5%	1/4W
R157	1-247-146-00	CARBON	4.3K	5%	1/4W
R158	1-249-561-11	CARBON	2.4K	5%	1/4W
R159	1-249-427-11	CARBON	6.8K	5%	1/4W
R160	1-249-415-11	CARBON	680	5%	1/4W
R161	1-249-425-11	CARBON	4.7K	5%	1/4W
R162	1-249-423-11	CARBON	3.3K	5%	1/4W
R163	1-249-421-11	CARBON	2.2K	5%	1/4W
R164	1-249-421-11	CARBON	2.2K	5%	1/4W
R165	1-249-441-11	CARBON	100K	5%	1/4W
R166	1-247-152-00	CARBON	8.2K	5%	1/4W
R167	1-249-432-11	CARBON	18K	5%	1/4W
R168	1-249-425-11	CARBON	4.7K	5%	1/4W
R169	1-249-393-11	CARBON	10	5%	1/4W
R170	1-247-883-00	CARBON	150K	5%	1/4W
R171	1-247-713-11	CARBON	1K	5%	1/4W
R173	1-249-429-11	CARBON	10K	5%	1/4W
R268	1-249-425-11	CARBON	4.7K	5%	1/4W
R301	1-247-717-11	CARBON	2.2K	1%	1/4W
R302	1-249-421-11	CARBON	2.2K	5%	1/4W
R303	1-249-433-11	CARBON	22K	5%	1/4W
R304	1-247-864-11	CARBON	24K	5%	1/4W
R305	1-249-408-11	CARBON	180	5%	1/4W
R306	1-249-436-11	CARBON	39K	5%	1/4W
R307	1-249-429-11	CARBON	10K	5%	1/4W
R308	1-247-713-11	CARBON	1K	1%	1/4W
R309	1-249-959-11	CARBON	33K	1%	1/4W
R310	1-215-452-00	METAL	20K	1%	1/6W
R311	1-249-433-11	CARBON	22K	5%	1/4W
R312	1-249-421-11	CARBON	2.2K	5%	1/4W
R313	1-247-862-11	CARBON	20K	5%	1/4W
R314	1-247-704-11	CARBON	220	5%	1/4W
R315	1-215-445-00	METAL	10K	1%	1/6W
R351	1-249-425-11	CARBON	4.7K	5%	1/4W
R414	1-247-704-11	CARBON	220	5%	1/4W
R451	1-249-425-11	CARBON	4.7K	5%	1/4W
R501	1-247-704-11	CARBON	220	5%	1/4W
R502	1-247-704-11	CARBON	220	5%	1/4W
R503	1-249-433-11	CARBON	22K	5%	1/4W
R511	1-249-429-11	CARBON	10K	5%	1/4W
R512	1-249-437-11	CARBON	47K	5%	1/4W
R513	1-249-437-11	CARBON	47K	5%	1/4W
R514	1-215-469-00	METAL	100K	1%	1/6W
R515	1-249-425-11	CARBON	4.7K	5%	1/4W
R516	1-249-425-11	CARBON	4.7K	5%	1/4W
R517	1-249-425-11	CARBON	4.7K	5%	1/4W
R518	1-249-433-11	CARBON	22K	5%	1/4W
R519	1-247-864-11	CARBON	24K	5%	1/4W
R520	1-249-441-11	CARBON	100K	5%	1/4W
R521	1-249-425-11	CARBON	4.7K	5%	1/4W
R523	1-249-441-11	CARBON	100K	5%	1/4W
R524	1-247-858-11	CARBON	13K	5%	1/4W
R525	1-247-846-11	CARBON	4.3K	5%	1/4W
R526	1-247-850-11	CARBON	6.2K	5%	1/4W
R527	1-249-440-11	CARBON	82K	5%	1/4W



Ref.No.	Part No.	Description				
R528	1-249-440-11	CARBON	82K	3%	1/4W	
R529	△ 1-212-851-00	FUSIBLE	5.6	5%	1/4W	F
R530	1-249-429-11	CARBON	10K	5%	1/4W	
R531	1-249-429-11	CARBON	10K	5%	1/4W	
R533	1-249-429-11	CARBON	10K	5%	1/4W	
R534	1-249-421-11	CARBON	2.2K	5%	1/4W	
R535	1-249-431-11	CARBON	15K	5%	1/4W	
R536	1-249-405-11	CARBON	100	5%	1/4W	
R537	1-249-441-11	CARBON	100K	5%	1/4W	
R538	1-249-417-11	CARBON	1K	5%	1/4W	
R539	1-249-417-11	CARBON	1K	5%	1/4W	
R540	1-249-409-11	CARBON	220	5%	1/4W	
R601	1-247-876-11	CARBON	75K	5%	1/4W	
R602	1-249-436-11	CARBON	39K	5%	1/4W	
R603	1-247-887-00	CARBON	220K	5%	1/4W	
R604	1-247-885-00	CARBON	180K	5%	1/4W	
R605	1-249-437-11	CARBON	47K	5%	1/4W	
R606	1-249-438-11	CARBON	56K	5%	1/4W	
R607	1-247-878-00	CARBON	91K	5%	1/4W	
R608	1-249-439-11	CARBON	68K	5%	1/4W	
R609	1-247-882-11	CARBON	130K	5%	1/4W	
R610	1-247-880-11	CARBON	110K	5%	1/4W	
R611	1-249-439-11	CARBON	68K	5%	1/4W	
R612	1-247-881-00	CARBON	120K	5%	1/4W	
R613	1-247-874-11	CARBON	62K	5%	1/4W	
R614	1-249-439-11	CARBON	68K	5%	1/4W	
R615	1-247-878-00	CARBON	91K	5%	1/4W	
R616	1-249-439-11	CARBON	68K	5%	1/4W	
R617	1-247-876-11	CARBON	75K	5%	1/4W	
R618	1-247-880-11	CARBON	110K	5%	1/4W	
R651	1-249-425-11	CARBON	4.7K	5%	1/4W	
R652	1-249-405-11	CARBON	100	5%	1/4W	
R653	1-249-435-11	CARBON	33K	5%	1/4W	
R654	1-249-425-11	CARBON	4.7K	5%	1/4W	
R701	1-249-413-11	CARBON	470	5%	1/4W	
R702	1-249-425-11	CARBON	4.7K	5%	1/4W	
R703	1-249-429-11	CARBON	10K	5%	1/4W	
R704	1-249-421-11	CARBON	2.2K	5%	1/4W	
R705	1-249-421-11	CARBON	2.2K	5%	1/4W	
R706	1-249-941-11	CARBON	5.6K	1%	1/4W	
R707	1-249-947-11	CARBON	10K	1%	1/4W	
R708	1-249-433-11	CARBON	22K	5%	1/4W	
R709	1-247-752-11	CARBON	1K	5%	1/2W	
R710	1-249-417-11	CARBON	1K	5%	1/4W	
R711	1-249-425-11	CARBON	4.7K	5%	1/4W	
R712	1-249-426-11	CARBON	5.6K	5%	1/4W	
R713	1-249-433-11	CARBON	22K	5%	1/4W	
R714	△ 1-202-850-00	SOLID	2.2		1/4W	F
R715	△ 1-202-850-00	SOLID	2.2		1/4W	F
R751	1-214-723-00	METAL	560	1%	1/4W	
R752	1-214-731-00	METAL	1.2K	1%	1/4W	
R753	1-214-713-00	METAL	220	1%	1/4W	
R754	1-249-429-11	CARBON	10K	5%	1/4W	
R755	1-214-721-00	METAL	470	1%	1/4W	
R801	1-249-441-11	CARBON	100K	5%	1/4W	
R802	1-249-429-11	CARBON	10K	5%	1/4W	
R803	1-249-441-11	CARBON	100K	5%	1/4W	

Ref.No.	Part No.	Description				
R805	1-249-433-11	CARBON	22K	5%	1/4W	
R806	1-247-903-00	CARBON	1M	5%	1/4W	
R807	1-247-887-00	CARBON	220K	5%	1/4W	
R808	1-247-887-00	CARBON	220K	5%	1/4W	
R809	1-249-435-11	CARBON	33K	5%	1/4W	
R810	1-249-435-11	CARBON	33K	5%	1/4W	
R811	1-249-409-11	CARBON	220	5%	1/4W	
R812	1-249-409-11	CARBON	220	5%	1/4W	
R813	1-249-418-11	CARBON	1.2K	5%	1/4W	
R814	1-249-423-11	CARBON	3.3K	5%	1/4W	
R815	1-249-423-11	CARBON	3.3K	5%	1/4W	
R816	1-249-417-11	CARBON	1K	5%	1/4W	
R817	1-249-417-11	CARBON	1K	5%	1/4W	
R818	1-249-415-11	CARBON	680	5%	1/4W	
R819	1-247-886-11	CARBON	1.6K	5%	1/4W	
R820	1-249-422-11	CARBON	2.7K	5%	1/4W	
R821	1-249-417-11	CARBON	1K	5%	1/4W	
R822	1-249-417-11	CARBON	1K	5%	1/4W	
R823	1-249-433-11	CARBON	22K	5%	1/4W	
R824	1-249-433-11	CARBON	22K	5%	1/4W	
R825	1-249-433-11	CARBON	22K	5%	1/4W	
R826	1-249-433-11	CARBON	22K	5%	1/4W	
R827	1-249-433-11	CARBON	22K	5%	1/4W	
R828	1-249-433-11	CARBON	22K	5%	1/4W	
R829	1-249-433-11	CARBON	22K	5%	1/4W	
R830	1-249-433-11	CARBON	22K	5%	1/4W	
R831	1-249-433-11	CARBON	22K	5%	1/4W	
R832	1-249-433-11	CARBON	22K	5%	1/4W	
R833	1-249-433-11	CARBON	22K	5%	1/4W	
R834	1-249-430-11	CARBON	12K	5%	1/4W	
R835	1-247-862-11	CARBON	20K	5%	1/4W	
R836	1-249-431-11	CARBON	15K	5%	1/4W	
R837	1-249-425-11	CARBON	4.7K	5%	1/4W	
R838	1-249-433-11	CARBON	22K	5%	1/4W	
R839	1-249-405-11	CARBON	100	5%	1/4W	
R841	1-249-413-11	CARBON	470	5%	1/4W	
R842	1-249-413-11	CARBON	470	5%	1/4W	
R843	1-249-413-11	CARBON	470	5%	1/4W	
R844	1-249-413-11	CARBON	470	5%	1/4W	
R845	1-249-413-11	CARBON	470	5%	1/4W	
R846	1-249-413-11	CARBON	470	5%	1/4W	
R847	1-249-413-11	CARBON	470	5%	1/4W	
R848	1-249-413-11	CARBON	470	5%	1/4W	
R849	1-249-429-11	CARBON	10K	5%	1/4W	
R901	1-249-407-11	CARBON	150	5%	1/4W	
R902	1-249-407-11	CARBON	150	5%	1/4W	
R903	1-249-411-11	CARBON	330	5%	1/4W	
R904	1-249-407-11	CARBON	150	5%	1/4W	
R905	1-249-441-11	CARBON	100K	5%	1/4W	
R906	1-249-441-11	CARBON	100K	5%	1/4W	
R907	1-249-441-11	CARBON	100K	5%	1/4W	
R908	1-249-441-11	CARBON	100K	5%	1/4W	
R909	1-249-441-11	CARBON	100K	5%	1/4W	
R910	1-249-441-11	CARBON	100K	5%	1/4W	
R911	1-249-441-11	CARBON	100K	5%	1/4W	
R912	1-249-441-11	CARBON	100K	5%	1/4W	
R913	1-249-441-11	CARBON	100K	5%	1/4W	

**Note:** The components identified by mark △ or dotted line with mark △ are critical for safety. Replace only with part number specified.

Ref.No.	Part No.	Description
R914	1-249-441-11	CARBON 100K 5% 1/4W
R915	1-249-441-11	CARBON 100K 5% 1/4W
R916	1-249-441-11	CARBON 100K 5% 1/4W
R917	1-249-441-11	CARBON 100K 5% 1/4W
R918	1-249-441-11	CARBON 100K 5% 1/4W
R919	1-249-429-11	CARBON 10K 5% 1/4W
R920	1-249-437-11	CARBON 47K 5% 1/4W
R921	1-249-437-11	CARBON 47K 5% 1/4W
R922	1-249-437-11	CARBON 47K 5% 1/4W
R923	1-215-452-00	METAL 20K 1% 1/6W
R924	1-215-452-00	METAL 20K 1% 1/6W
R925	1-215-452-00	METAL 20K 1% 1/6W
R926	1-215-452-00	METAL 20K 1% 1/6W
R927	1-215-452-00	METAL 20K 1% 1/6W
R928	1-215-452-00	METAL 20K 1% 1/6W
R929	1-215-452-00	METAL 20K 1% 1/6W
R930	1-215-445-00	METAL 10K 1% 1/6W
R931	1-215-445-00	METAL 10K 1% 1/6W
R932	1-215-445-00	METAL 10K 1% 1/6W
R933	1-215-445-00	METAL 10K 1% 1/6W
R934	1-215-445-00	METAL 10K 1% 1/6W
R935	1-215-445-00	METAL 10K 1% 1/6W
R936	1-215-460-00	METAL 43K 1% 1/6W
R937	1-215-425-00	METAL 1.5K 1% 1/6W
RV101	1-228-994-00	RES, ADJ, CARBON 10K
RV151	1-228-994-00	RES, ADJ, CARBON 10K
RV152	1-228-995-00	RES, ADJ, CARBON 22K
RV201	1-228-994-00	RES, ADJ, CARBON 10K
RV251	1-228-994-00	RES, ADJ, CARBON 10K
RV252	1-228-995-00	RES, ADJ, CARBON 22K
RV511	1-238-097-11	RES, VAR, CARBON 20K/20K (REC LEVEL)
RV512	1-238-085-11	RES, VAR, CARBON 20K/20K (PHONES LEVEL)
RV513	1-238-373-11	RES, VAR, CARBON 5K (BIAS)
RY501	1-515-688-11	RELAY
S511	1-571-741-11	SWITCH, ROTARY (DOLBY NR)
S512	1-571-742-11	SWITCH, ROTARY (MPX FILTER)
S701	1-570-103-21	SWITCH, PUSH (1 KEY) (POWER)
S901	1-554-596-21	SWITCH, KEY BOARD ( ■ )
S902	1-554-596-21	SWITCH, KEY BOARD ( ◀ )
S903	1-554-596-21	SWITCH, KEY BOARD ( ▶ )
S904	1-554-596-21	SWITCH, KEY BOARD ( ▷ )
S905	1-554-596-21	SWITCH, KEY BOARD (REC ●)
S906	1-554-596-21	SWITCH, KEY BOARD (PAUSE ■)

Ref.No.	Part No.	Description
S907	1-554-596-21	SWITCH, KEY BOARD (REC MUTE ○)
S908	1-554-596-21	SWITCH, KEY BOARD (TAPE OPERATION)
S909	1-554-596-21	SWITCH, KEY BOARD (RESET)
S910	1-554-596-21	SWITCH, KEY BOARD (MEMORY)
S911	1-554-208-00	SWITCH, SLIDE (TIMER)
SPK151	1-235-186-00	ENCAPSULATED COMPONENT
SPK251	1-235-186-00	ENCAPSULATED COMPONENT
T151	1-433-342-11	TRANSFORMER, BIAS OSCILLATION
T251	1-433-342-11	TRANSFORMER, BIAS OSCILLATION
T511	1-433-343-11	TRANSFORMER, BIAS OSCILLATION
T701	△, 1-449-468-11	TRANSFORMER, POWER
X801	1-567-772-11	VIBRATOR, CERAMIC (4.19MHz)

ACCESSORY & PACKING MATERIAL

1-551-734-11	CORD, CONNECTION (RK-74A)
3-786-643-11	MANUAL, INSTRUCTION
*3-349-005-01	CUSHION
*3-577-909-01	INDIVIDUAL CARTON

Note: The components identified by mark △ or dotted line with mark △ are critical for safety. Replace only with part number specified.