

TC-K590

SERVICE MANUAL

Canadian Model
AEP Model
UK Model



* Dolby noise reduction and HX Pro headroom extension manufactured under license from Dolby Laboratories Licensing Corporation. HX-Pro originated by Bang & Olufsen.

"DOLBY", the double-D symbol  and "HX PRO" are trademarks of Dolby Laboratories Licensing Corporation.

Model Name Using Similar Mechanism	TC-K570
Tape Transport Mechanism Type	TCM-200V8

SPECIFICATIONS

Recording system 4-track 2-channel stereo
Fast winding time Approx. 90 sec. (with Sony C-60 cassette)
Bias AC bias
Heads Erasing head × 1 (S&F head)
Recording head × 1 (SD head)
Playback head × 1 (SD head)
Motors Capstan motor × 1 (DC servo motor)
Reel motor × 1 (DC motor)
ASIST (mechanical drive) motor × 1 (DC motor)

Signal-to-noise ratio (at peak level)

Cassette (Dolby NR OFF)	Type IV (Sony Metal-S/Select)	Type II (Sony UX-S)	Type I (Sony HF-S)
	60 dB	59 dB	57 dB

Measured at peak level weighted without NR. The S/N is improved by about 15 dB at 500 Hz and by about 20 dB about 1 kHz with Dolby-C NR on, and by 5 dB at 1 kHz and by 10 dB about 5 kHz with Dolby-B NR on.

Harmonic distortion 0.4% (with Sony Type I, 160 nWb/m 315 Hz, 3rd H.D.)
1.5% (with Sony Type IV, 250 nWb/m 315 Hz, 3rd H.D.)

Frequency response (DOLBY NR OFF)

Type IV cassette (Sony Metal-S/Select)	20 - 20,000 Hz (±3 dB, IEC) 20 - 16,000 Hz (±3 dB (-4dB recording))
Type II cassette (Sony UX-S)	20 - 18,000 Hz (±3 dB, IEC)
Type I cassette (Sony HF-S)	20 - 17,000 Hz (±3 dB, IEC)

Wow and flutter ± 0.09% W.Peak (IEC)
0.05% W.RMS (NAB)
± 0.14% W.Peak (DIN)

Inputs

Line inputs (phono jacks)	Sensitivity	0.16 V
	Input impedance	47 k ohms

Outputs

Line outputs (phono jacks)	Rated output level	0.5 V at a load impedance of 47 k ohms
	Load impedance	Over 10 k ohms
Headphones (stereo phone jack)	Output level	0 - 3 mW at a load impedance of 32 ohms

General

Power requirements

AEP, Germany model :
220 - 230 V AC, (or 240 V AC adjustable by Sony personnel), 50/60 Hz
Canadian model : 120 V AC, 60 Hz
UK model :
240 V AC (or 220 V AC adjustable by Sony personnel), 50/60 Hz

Power consumption

19 W

Dimensions

Approx. 430 × 123 × 300 mm (w/h/d)
(17 × 4⁷/₈ × 11⁷/₈ inches)

Weight

including projecting parts and controls
TC-K690: Approx 4.9 kg (10 lbs 13 oz)
TC-K590: Approx 4.7 kg (10 lbs ? oz)

Supplied accessories

Audio connecting cords (2)

Optional accessory

Wireless remote control unit RM-J701

Design and specifications are subject to change without notice.

Note

This appliance conforms with EEC Directive 87/308/EEC regarding interference suppression.



STEREO CASSETTE DECK
SONY®

TABLE OF CONTENTS

<u>Section</u>	<u>Title</u>	<u>Page</u>
1. GENERAL		3
2. DISASSEMBLY		4
3. PIN DESCRIPTION		7
4. ADJUSTMENTS		
4-1. Mechanical Adjustments		8
4-2. Electrical Adjustment		11
5. DIAGRAMS		
5-1. Circuit Boards Location		15
5-2. IC Block Diagram		15
5-3. Printed Wiring Boards		17
5-4. Schematic Diagram		21
5-5. Semiconductor Lead Layouts		26
6. EXPLODED VIEWS		
6-1. Chassis Section		27
6-2. Front Panel Section		28
6-3. Mechanism Section 1		29
6-4. Mechanism Section 2		30
7. ELECTRICAL PARTS LIST		
		31

MODEL IDENTIFICATION

- Specification Label -

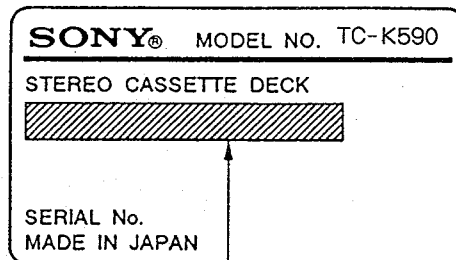

Canadian model : AC120V 60Hz 19W
 UK model : AC240~50/60Hz
 AEP, Germany model : AC220-230~50/60Hz

SAFETY-RELATED COMPONENT WARNING!!

COMPONENTS IDENTIFIED BY MARK Δ OR DOTTED LINE WITH MARK Δ ON THE SCHEMATIC DIAGRAMS AND IN THE PARTS LIST ARE CRITICAL TO SAFE OPERATION. REPLACE THESE COMPONENTS WITH SONY PARTS WHOSE PART NUMBERS APPEAR AS SHOWN IN THIS MANUAL OR IN SUPPLEMENTS PUBLISHED BY SONY.

ATTENTION AU COMPOSANT AYANT RAPPORT À LA SÉCURITÉ!



LES COMPOSANTS IDENTIFIÉS PAR UNE MARQUE Δ SUR LES DIAGRAMMES SCHÉMATIQUES ET LA LISTE DES PIÈCES SONT CRITIQUES POUR LA SÉCURITÉ DE FONCTIONNEMENT. NE REMPLACER CES COMPOSANTS QUE PAR DES PIÈCES SONY DONT LES NUMÉROS SONT DONNÉS DANS CE MANUEL OU DANS LES SUPPLÉMENTS PUBLIÉS PAR SONY.

Identifying the Parts

Front Panel

For details, refer to the page number indicated in parenthesis.

- 1 POWER switch
- 2 Cassette holder
- 3 Counter buttons
- 4 MEMORY button (26, 28)
- 5 LINEAR COUNTER (26)
- 6 MEMORY indicator
- 7 PEAK LEVEL METER (34)
- 8 TAPE TYPE indicator
- 9 MONITOR button (36)
- 10 DISPLAY MODE button (18)
- 11 CALIBRATION button (42)
- 12 MPX FILTER button (34)
- 13 BALANCE control (30)
- 14 REC (recording) LEVEL control (30, 34)

- * Remote control sensor
- You can remotely control this cassette deck with:
 - A remote commander that came with a Sony amplifier or receiver if it has the  mark and cassette deck control capability.
 - An optional Sony remote commander with the  mark and cassette deck control capability.

(Continued on next page.)

Hooking Up the System

Before You Begin

- Turn off the power to all equipment to be connected before making any connection.
 - Note that the red plug of the supplied connecting cord is for right-channel (R) connection and the white plug for left-channel (L) connection.
- See Fig. **A**.
- a) White
 - b) Red
- The connecting cords should be fully inserted into the jacks. A loose connection may cause hum pickup.

Hook-up Example

- Fig. **B** shows how to connect the unit to an amplifier.
- a) to an AC outlet
 - b) for recording
 - c) for playback
 - d) Amplifier
 - e) to a wall outlet

The arrow  shows the direction of the signal flow.

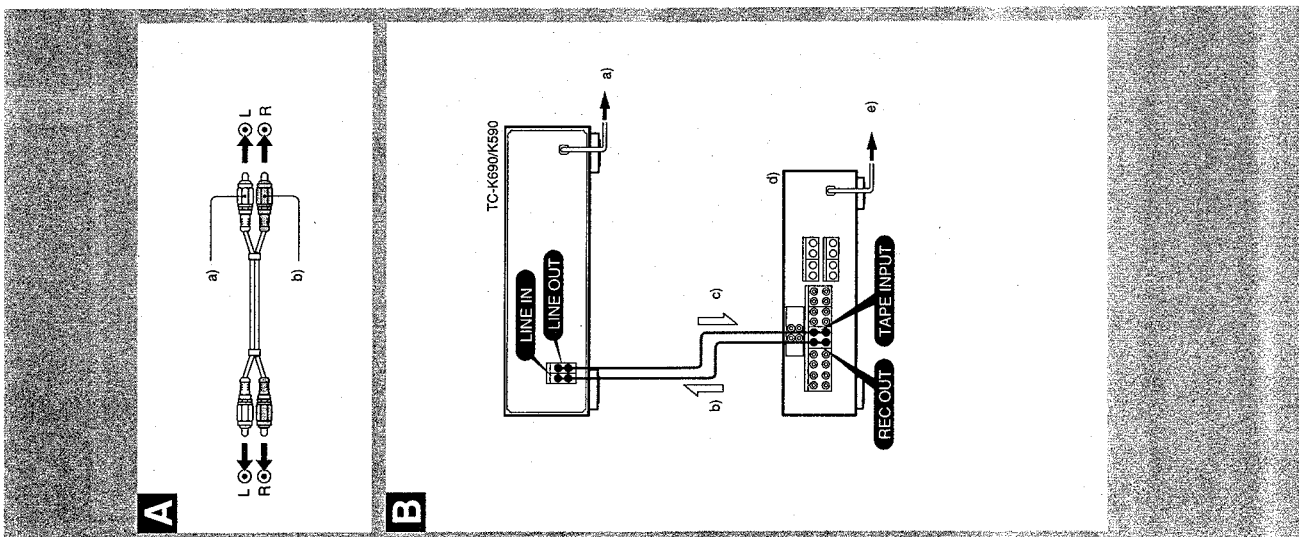
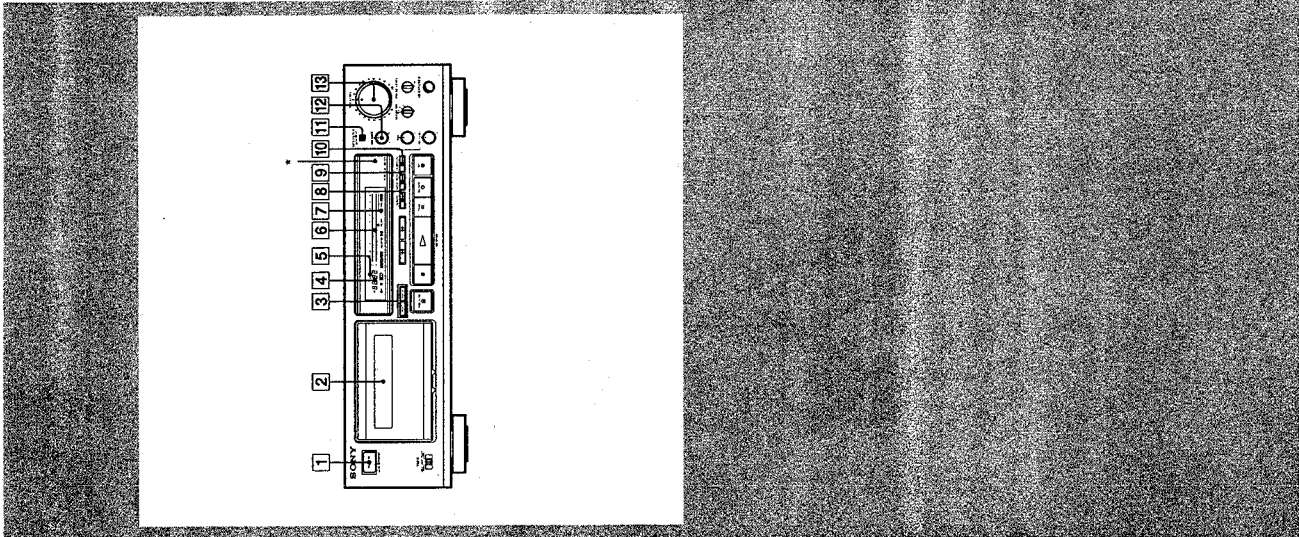

SECTION 2 DISASSEMBLY

NOTE: Follow the disassembly procedure in the numerical order given.

MECHANISM BLOCK

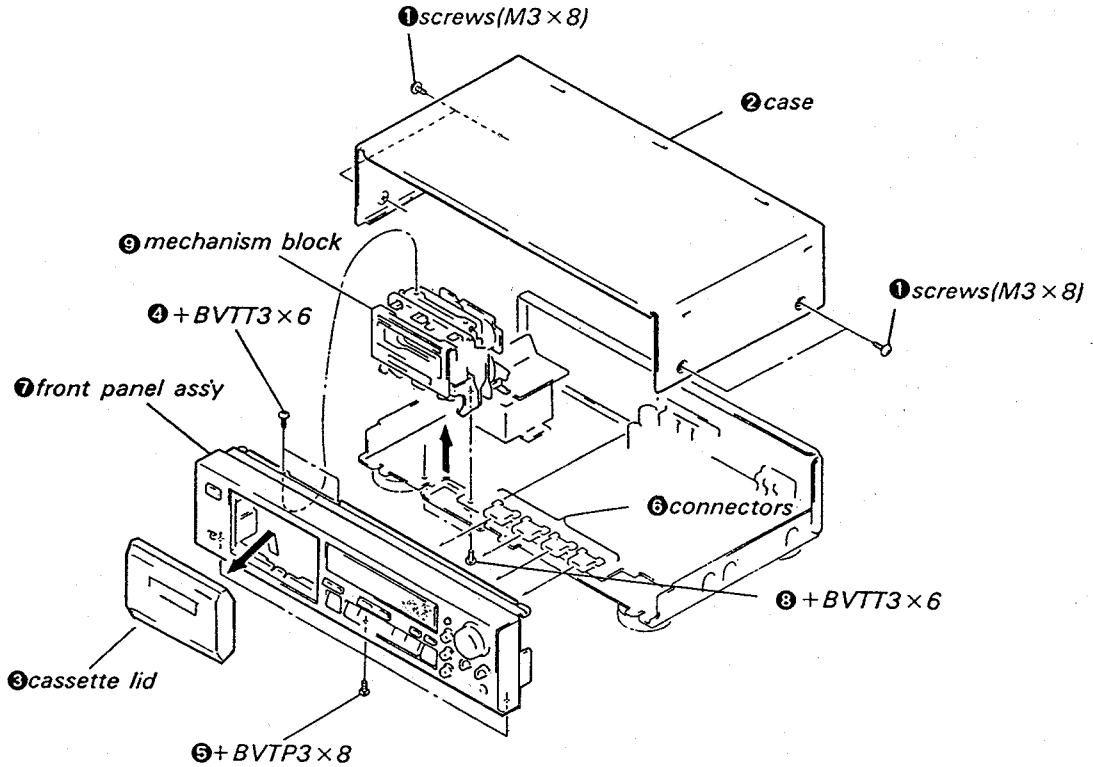

CASSETTE HOLDER

⑤ Push lever (lifter) in the direction of arrow and remove cassette holder.

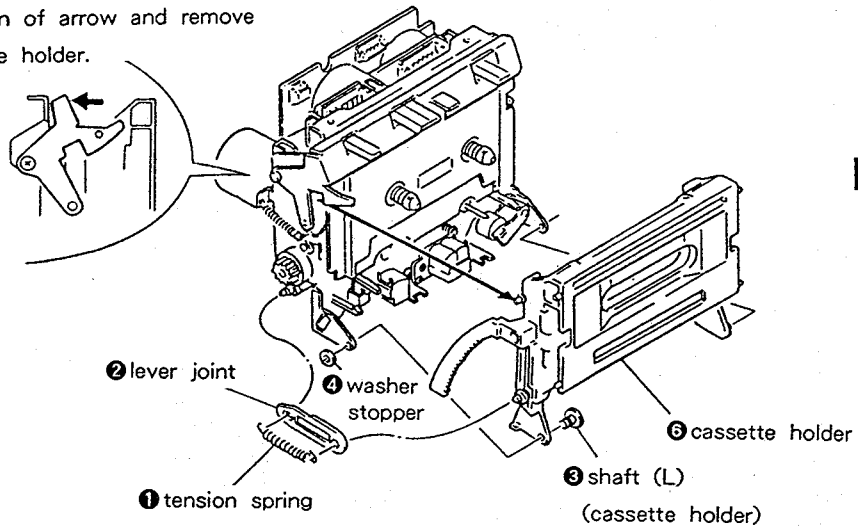

ORNAMENTAL PLATE

② Push lever (lifter) in the direction of arrow and remove ornamental plate.

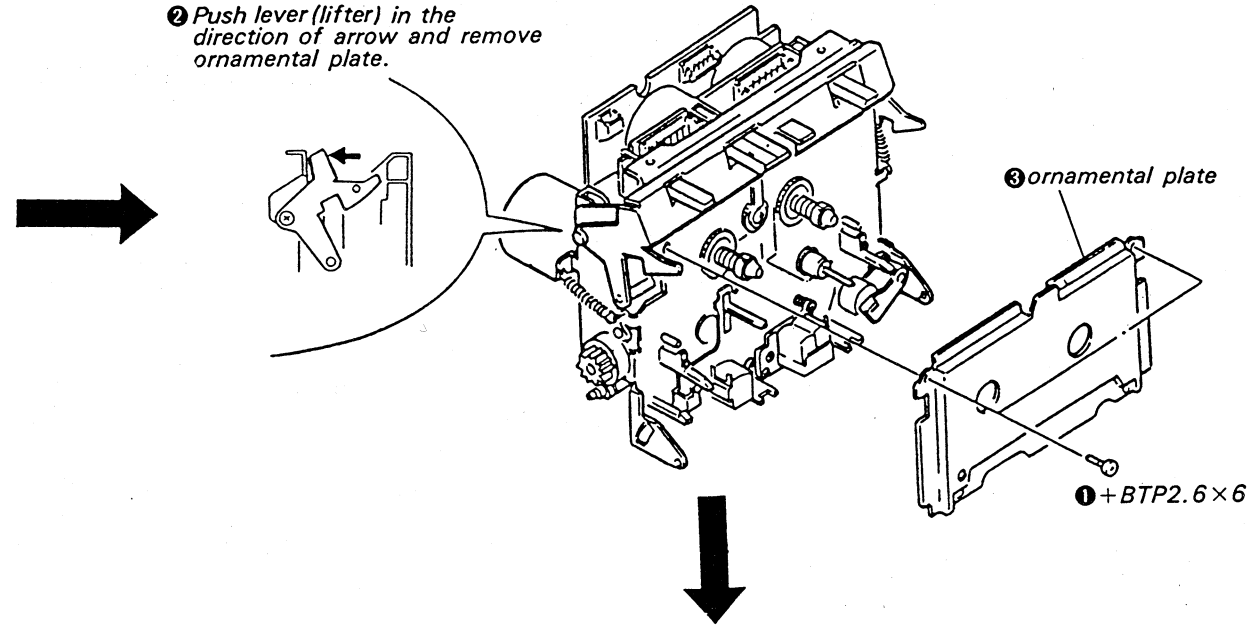

CAPSTAN MOTOR / FLYWHEEL

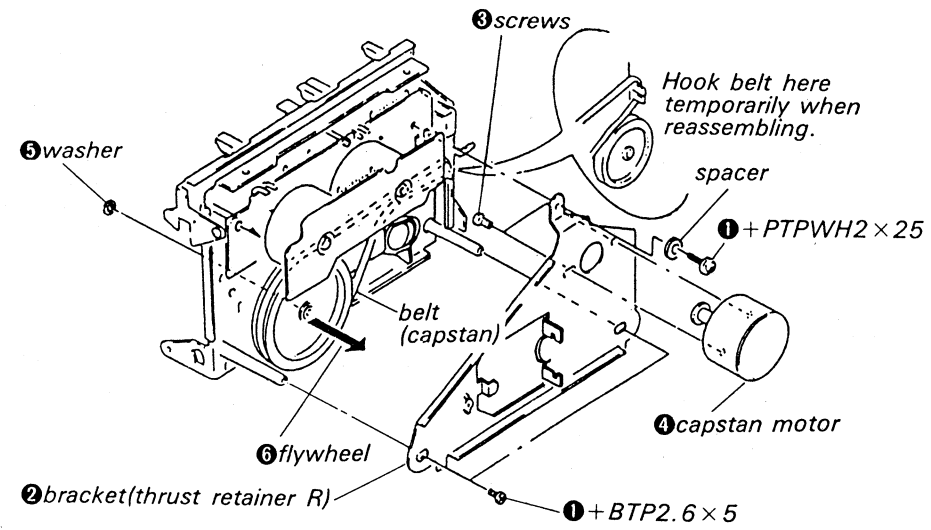

REEL AND ASSIST MOTORS

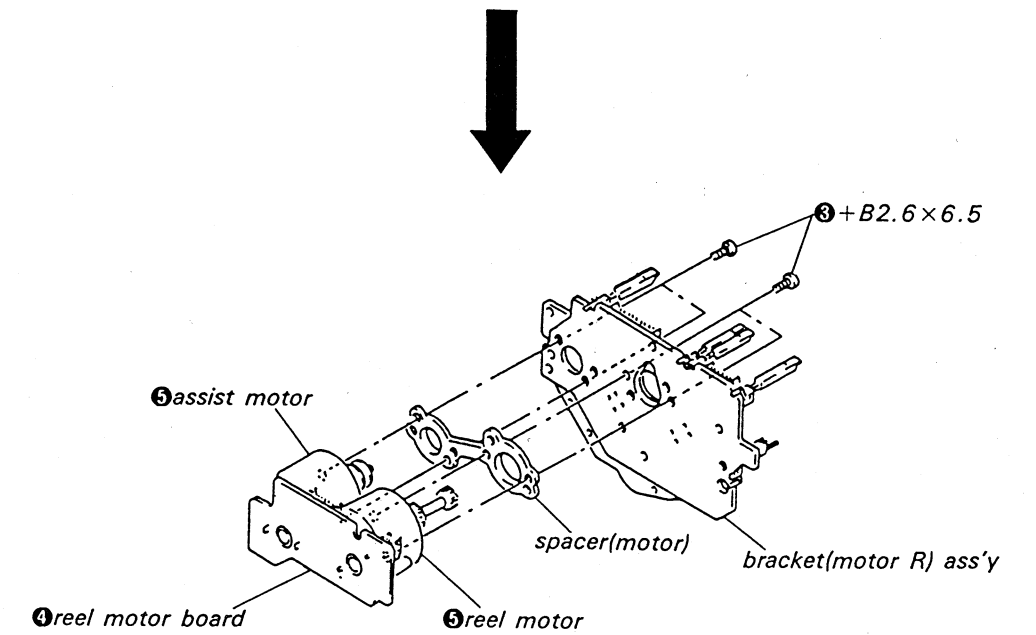
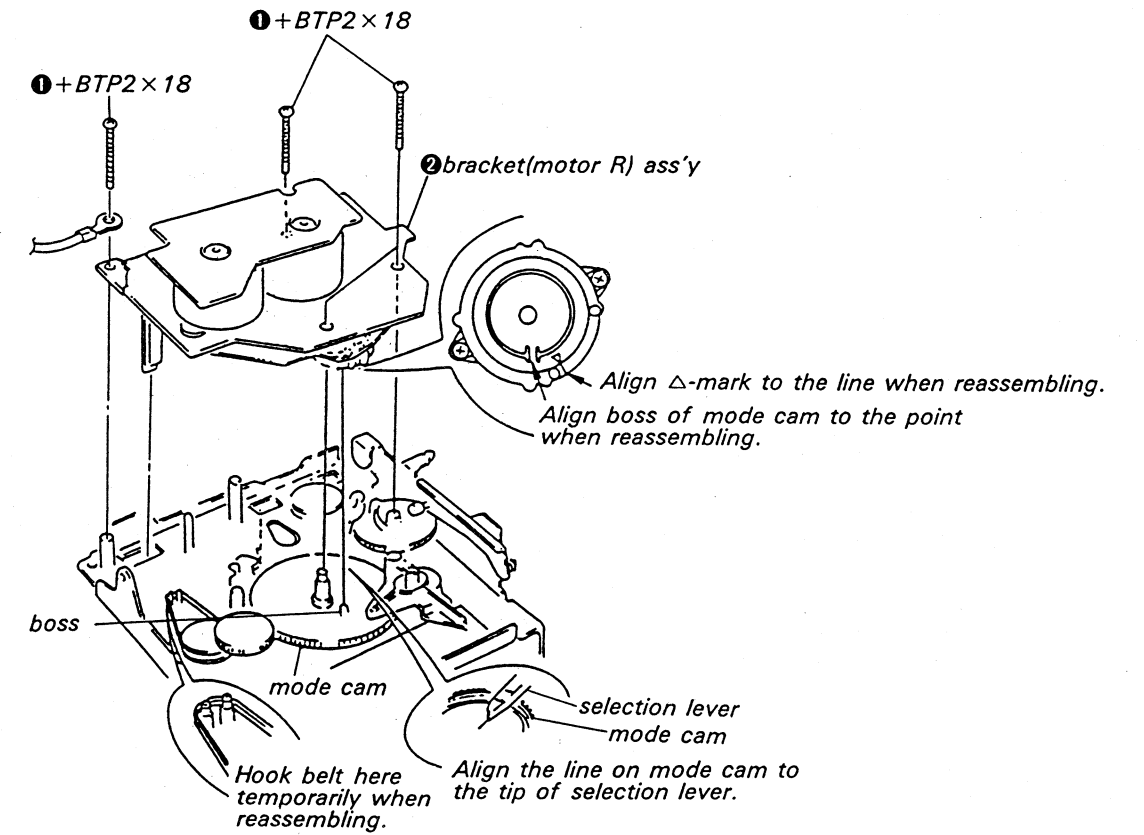

SECTION 3

PIN DESCRIPTION

IC701 M50941-728SP(MICRO COMPUTER)

The M50941-728SP function are described below.

Pin No.	Pin Name	I/O	Description
1	V _{REF}	I	Internal A/D port reference voltage input.
2	KEY 7	I	Key input port. 0V = OPEN/CLOSE. 1V = STOP, 2V = REW, 3V = FF, 4V = REC.
3	KEY 6	I	key input port. 0V = PLAY, 1V = PAUSE, 2V = REC MUTE.
4	KEY 5	I	Key input port. 0V = RESET, 1V = MEMORY, 2V = DISPLAY MODE, 3V = MONITOR.
5	METER-L	I	Signal input for level meter-L.
6	METER-R	I	Signal input for level meter-R.
7	TIMER	I	Timer REC/PLAY switch input. 0V = TIMER REC, 1V = TIMER PLAY, 2V = OFF.
8	T. PULSE	I	Take-up reel base sensor input.
9	S. PULSE	I	Supply reel base sensor input.
10	AMS. SIG	I	AMS signal input. No song detected = Low. Song detected = High.
11	BIAS	O	Bias oscillation on and off control.
12	MO3V	O	Motor speed control. STOP/PLAY = Low, FF/REW = High.
13	MO4. 5V	O	Motor speed control. STOP/PLAY = High, FF/REW = Low.
14	MO-FWD	O	Reel motor rotates.
15	MO-REV	O	Reel motor rotates in reverse.
16	MO-DOWN	O	Head base DOWN output of the mechanical block.
17	MO-UP	O	Head base UP output of the mechanical block.
18	HALF-SW	I	HALF switch input of the mechanical block.
19	REC-SW	I	REC switch input of the mechanical block.
20	DOOR-SW	I	DOOR switch input of the mechanical block.
21	CLOSE-SW	I	CLOSE switch input of the mechanical block.
22	OPEN-SW	I	OPEN switch input of the mechanical block.
23	POWER-OUT	O	"Low" for power off procedure after POWER switch is turned off.
24	POWER-IN	I	Power(AC) off detection.
25	SIRCS	I	Remote control signal input.
26	V _{ss}	-	GND
27	RESET	I	System reset input.
28	XI	I	Clock input(4.19MHz).
29	XO	O	Clock output.
30	XCI	-	Not used.
31	XCO	-	Not used.
32	V _{ss}	-	GND
33	-	-	Not used.
34	PAT3	I	Rotary encoder input to detect the position of the head base of the mechanical block.
35	PAT1	I	
37	PAT0	I	
38	-25V	-	Power supply for driving the fluorescent indicator tube.
39	FL-p	O	Segment data output for the fluorescent indicator tube FL751.
40	FL	I	
54	FL-a	O	
55	FL-G5	O	Common data output for the fluorescent indicator tube FL751.
56	FL	I	
59	FL-G1	O	
60	MONITOR	O	Source monitor control. Low = TAPE, High = SOURCE.
61	REC-MUTE	O	REC MUTE control. Low = MUTE.
62	LINE-MUTE	O	LINE MUTE control. Low = MUTE.
63	AV _{cc}	-	Analog power supply(+5V).
64	V _{cc}	-	Power supply(+5V).

SECTION 4 ADJUSTMENTS

4-1. MECHANICAL ADJUSTMENTS

PRECAUTION

1. Clean the following parts with a denatured-alcohol-moistened swab:

record/playback head	pinch roller
erase head	rubber belts
capstan	idler
2. Demagnetize the record/playback head with a head demagnetizer.
3. Do not use a magnetized screwdriver for the adjustments.
4. After the adjustments, apply suitable locking compound to the parts adjusted.

Tape Path Adjustment

Note: When using the adjustment methods for other than replacement reasons, please do not tamper unnecessarily with the adjustment screws or the erasehead because either the supply pinch roller guide or the record/playback head will be made the standard tape paths. Moreover, when it is necessary to adjust and replace two or more of any of the heads and/or pinch rollers, replace them one by one, completely taking out the first tape path, and then replacing the second one.

Preparation:

1. Mirror cassette CQ009C 8-909-708-01
(or CQ012C 8-909-708-02)

If one does not have this, cut out the sections of a 120-minute cassette shell as indicated below and use that cassette.

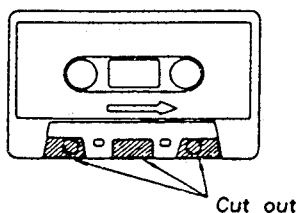

2. Phillips screwdriver (medium-size):
For the head adjustment screws
- Blade-type screwdriver (large-size):
For the supply pinch roller adjustment screws
3. Pen light
4. WS-48B (3 kHz, 0 dB)
5. P-4-A100 (10 kHz, -10 dB)

Adjustment Position: As seen from the cassette, side (top) and MD as seen head on (bottom).

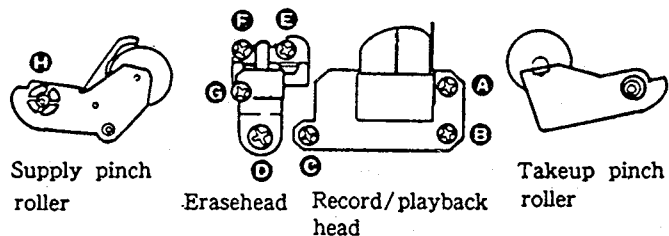
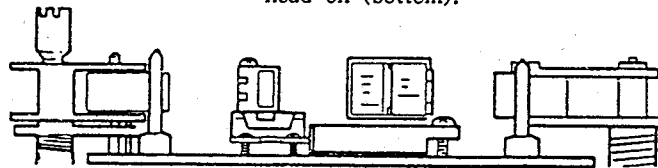

Definition of Terms: The figures are of a record/playback head.

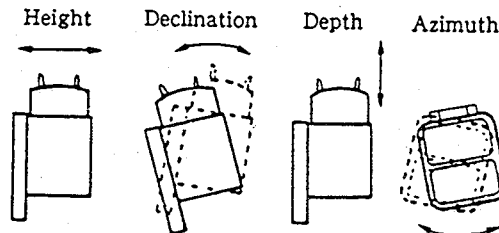

Adjustment Method :

Supply Pinch Roller

Note : Only perform this adjustment when the supply pinch roller is to be replaced.

1. Insert the mirror cassette and put the unit in record/playback mode.
2. Check to see whether the tape is curling at the record/playback head guide or the pinch roller guide.

If it is curling, remove the curl by adjusting the Ⓜ tape curl adjustment screw. Then, check that the tape is running past the middle of the erasehead.

Record/playback Head

Note : Only perform this adjustment when the record /playback head is to be replaced.

1. Insert the mirror cassette and put the unit in record/playback mode.
2. (**Height Adjustment**) Check to see if the tape is curling at the tape guide of the head. If it is curling, tighten screws Ⓐ , Ⓑ , and Ⓒ , respectively by the same angle, moving the head so that it remains at the same angle throughout the procedure. If it curls on the bottom side of the mirror cassette (actually the inner side), tighten all the screws equally ; but loosen them if the tape begins to curl on the top side (outer side).

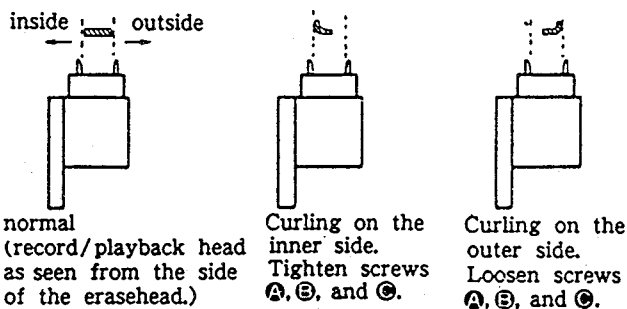

3. (**Declination Adjustment**) While in the record/ playback position, set the back tension to 0 (wind the supply reel with something thin like a pencil in a counterclockwise direction) and make sure there is no curling or shifting (shifting up/ shifting down) at the guide of the record/ playback head.

Because shifting can only occur due to a difference in the width of the tape and that of the tape guides (curling will otherwise occur), it is necessary to pay close attention since it can be easily overlooked.

When there is a shift, tighten screws Ⓑ and Ⓒ equally and change the declination of the head. If the tape is shifting up, tighten the screws, and if it is shifting down, loosen them.

4. Repeat the adjustments in steps 2 and 3 and fine adjust the height and the declination.
5. (**Preliminary Azimuth Adjustment**) After demagnetizing and cleaning the adjustment head, play back WS-48B (3 kHz, 0 dB). Turn screw Ⓒ so that the reading on the level meter of the unit or that of the level meter connected to LINE OUT is maximized. If the screw is turned at least half a revolution, repeat the adjustments from step 1.
6. (**Tape Path Check**) Connect the oscilloscope to LINE OUT and play back P-4-A100 (10 kHz, -10 dB) to display a resurge waveform. After 20 seconds of record/playback (after the tension within the loop has been increased sufficiently), make sure the variation in the resurge is within ± 90 degrees (within ± 45 degrees is desired). If the variation is greater than this, it is because the declination and/or the height adjustment is not perfect. Repeat the adjustments from step 1.

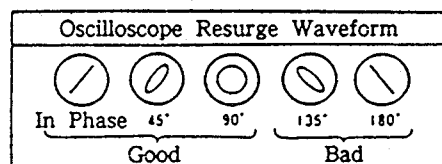
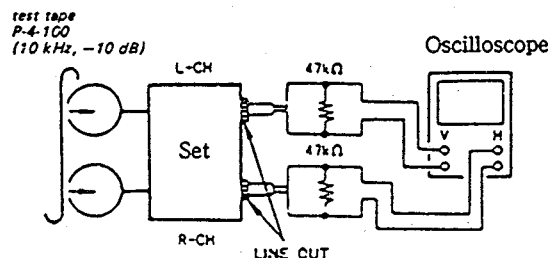

Adjustment Method :

Supply Pinch Roller

Note : Only perform this adjustment when the supply pinch roller is to be replaced.

1. Insert the mirror cassette and put the unit in record/playback mode.
2. Check to see whether the tape is curling at the record/playback head guide or the pinch roller guide.

If it is curling, remove the curl by adjusting the Ⓢ tape curl adjustment screw. Then, check that the tape is running past the middle of the erasehead.

Record/playback Head

Note : Only perform this adjustment when the record /playback head is to be replaced.

1. Insert the mirror cassette and put the unit in record/playback mode.
2. (**Height Adjustment**) Check to see if the tape is curling at the tape guide of the head. If it is curling, tighten screws Ⓐ , Ⓑ , and Ⓒ , respectively by the same angle, moving the head so that it remains at the same angle throughout the procedure. If it curls on the bottom side of the mirror cassette (actually the inner side), tighten all the screws equally ; but loosen them if the tape begins to curl on the top side (outer side).

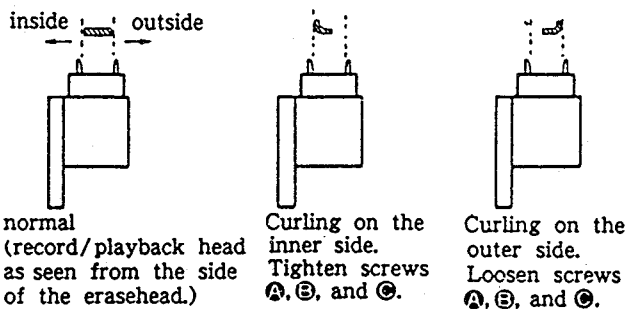

3. (**Declination Adjustment**) While in the record/ playback position, set the back tension to 0 (wind the supply reel with something thin like a pencil in a counterclockwise direction) and make sure there is no curling or shifting (shifting up/ shifting down) at the guide of the record/ playback head.

Because shifting can only occur due to a difference in the width of the tape and that of the tape guides (curling will otherwise occur), it is necessary to pay close attention since it can be easily overlooked.

When there is a shift, tighten screws Ⓑ and Ⓒ equally and change the declination of the head. If the tape is shifting up, tighten the screws, and if it is shifting down, loosen them.

4. Repeat the adjustments in steps 2 and 3 and fine adjust the height and the declination.
5. (**Preliminary Azimuth Adjustment**) After demagnetizing and cleaning the adjustment head, play back WS-48B (3 kHz, 0 dB). Turn screw Ⓒ so that the reading on the level meter of the unit or that of the level meter connected to LINE OUT is maximized. If the screw is turned at least half a revolution, repeat the adjustments from step 1.
6. (**Tape Path Check**) Connect the oscilloscope to LINE OUT and play back P-4-A100 (10 kHz, -10 dB) to display a resurge waveform. After 20 seconds of record/playback (after the tension within the loop has been increased sufficiently), make sure the variation in the resurge is within ± 90 degrees (within ± 45 degrees is desired). If the variation is greater than this, it is because the declination and/or the height adjustment is not perfect. Repeat the adjustments from step 1.

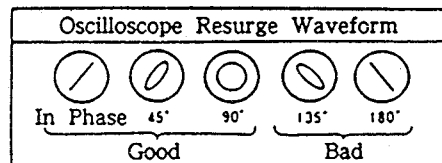
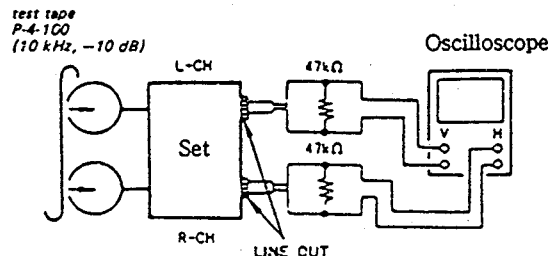

Erasehead

Note: Only perform this adjustment when the erasehead is to be replaced.

1. Insert the mirror cassette and put the unit in record/playback mode.
2. (**Azimuth Adjustment**) Adjust the azimuth of the erasehead by adjusting screws ③ and ④ so that the tape runs as evenly as possible.

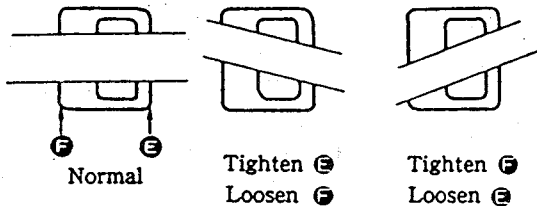

(The erasehead as seen when erasing the mirror cassette.)

3. (**Height adjustment**) Turn screws ①, ②, and ⑤ all by the same angle so that the portions of the erasehead visible at top and bottom are nearly of equal width. If the width at the top is greater, tighten the screws; if the width at the bottom is greater, loosen the screws.

Erasehead (The erasehead as seen through the mirror cassette.)

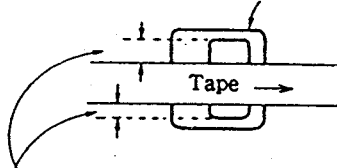

Make these the same width.

4. (**Declination Adjustment**) Leaving it in the playback position, put the back tension to 0 and make certain the erasehead part and supply pinch roller guide part do not shift. If there is a shift, turn the screw ⑥ and change the declination. Looking at it using the mirror cassette, if the tape shifts up, tighten the screw, and if it shifts down, loosen the screw.
5. Repeat the adjustments beginning with step 2 and fine adjust the height and declination. And make sure the tape does not curl up on the pinch roller guide or the guide part of the record/playback head.
6. (**Depth Adjustment**) In order to make the entire head play the tape smoothly, and to make sure the depth of the erasehead is neither too shallow nor too deep, loosen screw ⑦ a bit.

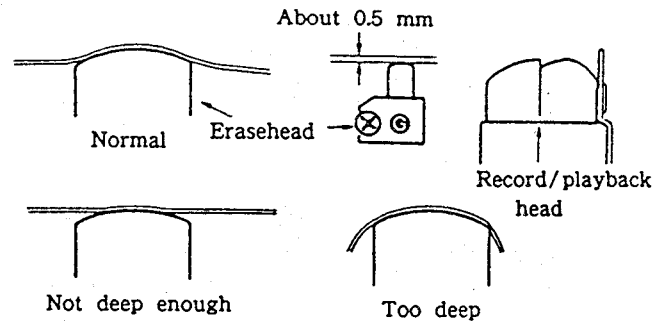

Check

1. Check to make sure that there are no curls or shifts throughout the whole tape path and that the tape runs smoothly.
2. Reapply the locking compound to the adjusted screws. (The locking compound should only be applied to screw ③ after the azimuth has been adjusted.)

TORQUE MEASUREMENT

Torque	Torque meter	Meter reading
FWD	CQ-102C	28-60 g · cm (0.39-0.83 oz · inch)
FWD Back tension	CQ-102C	7-11 g · cm (0.097-0.15 oz · inch)
FF, REW	CQ-201B	65-90 g · cm (0.9-1.25 oz · inch)

Pinch Roller Pressing Force Measurement

Mode: playback

Hook needle of the tension gauge to the pinch roller shaft and push back pinch roller to detach it from capstan. Then, return it gradually to capstan and read the gauge when the pinch roller begins turning.

Standard Limits:

Take-up side: 270-350 g (9.5-120 oz)

Supply side: 180-280 g (6.4-9.9 oz)

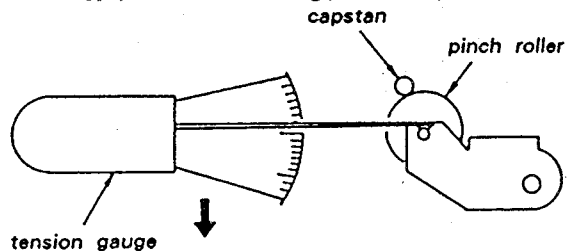

4-2. ELECTRICAL ADJUSTMENTS

Note: The adjustment should be performed in the order given in the service manual. As a rule, adjustments about playback should be performed before those about recording. The adjustments should be performed before for both L-CH and R-CH.

- Switches and controls should be set as follows unless otherwise specified.
 - DOLBY NR switch: OFF
 - MPX FILTER switch: OFF
 - MONITOR switch: Tape
- Standard Record: Deliver the standard input signal level to the input jack and set the REC LEVEL control to obtain the standard output signal level.

Record Mode

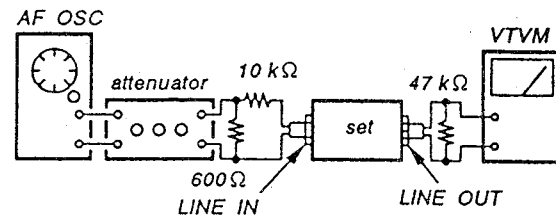

Standard Input Level

input terminal	LINE IN
source impedance	10 kΩ
input level	0.5V (-3.8dB)

Standard Output Level

output terminal	LINE OUT
load impedance	47 kΩ
output level	0.5V (-3.8dB)

Test Tape

Type	Signal	Used for
P-4-A100	10 kHz, -10 dB	Azimuth Adjustment
P-4-L300	315 Hz, 0 dB	PB Level Adjustmet
WS-48B	3 kHz, 0 dB	Tape Speed Adjustment

Test Mode

This set will get into test mode by shorting the pins of CNE702 (TEST) on MAIN board before turning the power on.

Record/Playback Head Azimuth Adjustment

Porcedure:

- Mode: FWD playback

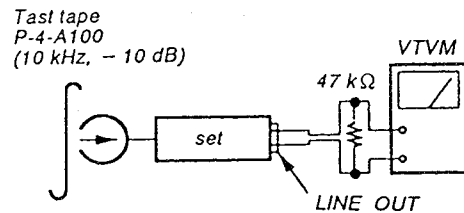

- Turn the adjustment screw for the maximum output levels. If these levels do not match, turn the adjustment screw until both of output levels match together within 1 dB.

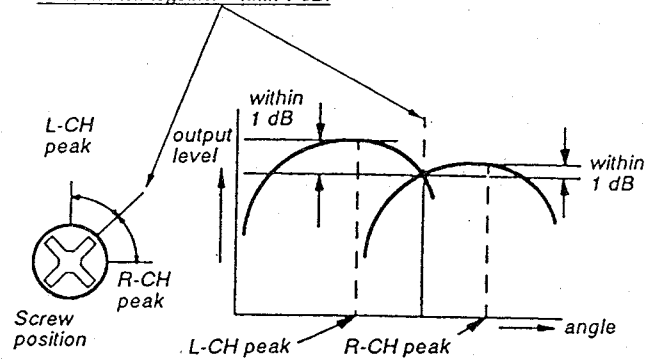

- Phase Check
Mode: playback

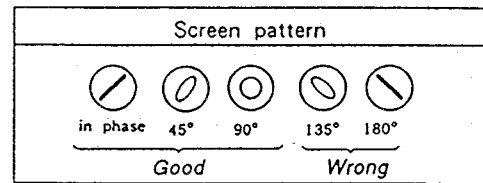
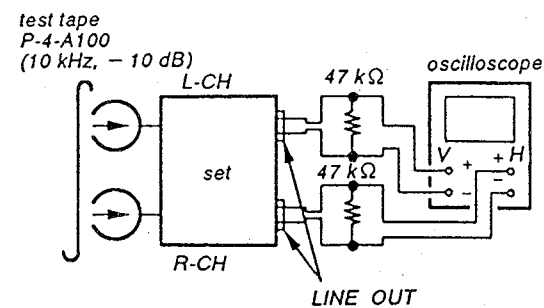

- After the adjustment, lock the screws with locking compound.

Adjustment Location: Record/Playback head

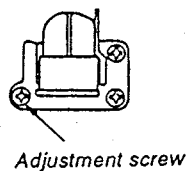

Tape Speed Adjustment

Setting:

Test pin CNE702: short

Procedure:

Mode: playback

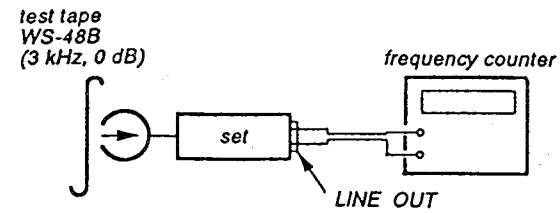

- Set to FWD playback mode.
- Adjust motor rear side (variable resistor) so that the frequency counter reading becomes $3,000 \pm 15$ Hz.

Adjustment Location: motor rear side (M1053)

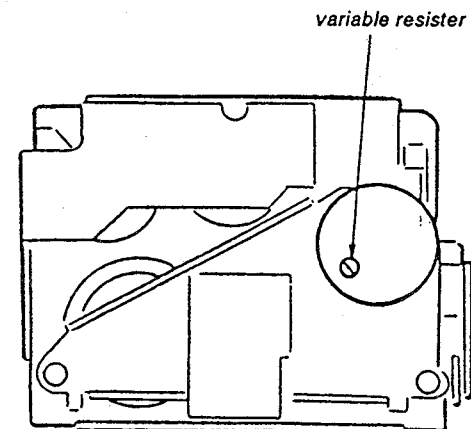

Playback Level Adjustment

Procedure:

Mode: playback
test tape P-4-L300 (315 Hz, 0 dB)

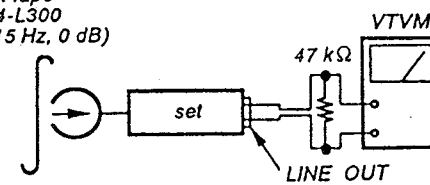

Adjust RV121 (L-ch) and RV221 (R-ch) so that the reading on VTVM meets the adjustment limits below.

Adjustment Limits:

LINE OUT level: -8.2dB to -7.2dB (0.301 to 0.338V)
Level difference between channels: less than 0.5 dB

Check that the LINE OUT level does not change even if Playback and Stop operation is repeated several times.

Adjustment Location: MAIN board

Bias Consumption Current Adjustment

Procedure:

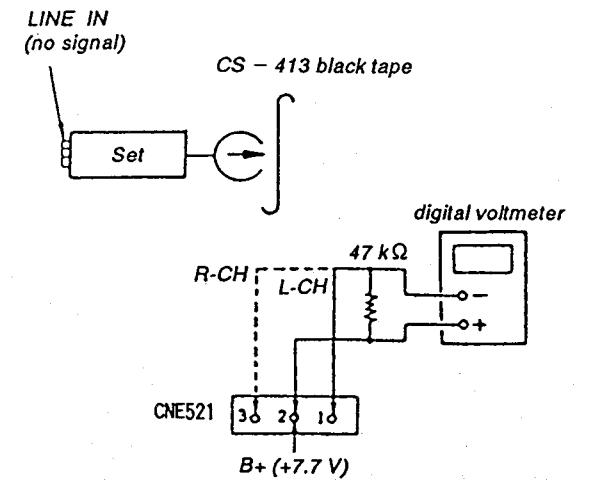

- Set RV181(L-CH) and RV281(R-CH) to mechanical center and turn the set recording mode.
- Connect digital voltmeter as shown by the following table.
- Adjust the following transformers for the minimum readings on the digital voltmeter.

	Measurement Point	Adjustment Part	Value
L-ch	① and ②, CNE521	T181	not more than 200mV
R-ch	③ and ②, CNE521	T281	

Adjustment Location: MAIN (A) board

Record Bias Adjustment

Setting:

REC LEVEL control: Standard Record (see page 11)
test pin CNE702: short

Procedure:

- Mode: record

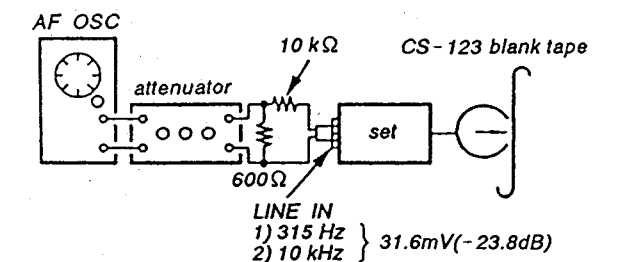

- Mode: playback

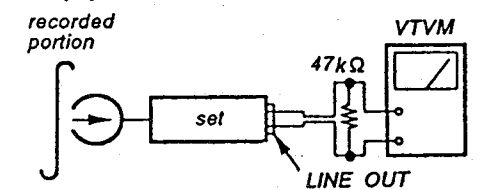

Playback the signal recorded in step 1. Confirm that the 10 kHz playback output is 0 ± 0.5 dB relative to the 315 Hz output. If necessary, adjust RV181 (L-ch) and RV281 (R-ch) for repeat the steps given above.

Adjustment Location: MAIN BOARD

Record Level Adjustment

Setting:
 REC LEVEL control: Standard Record (see page 11)
 test pin CNE702 : short

Procedure:
 1. Mode: record

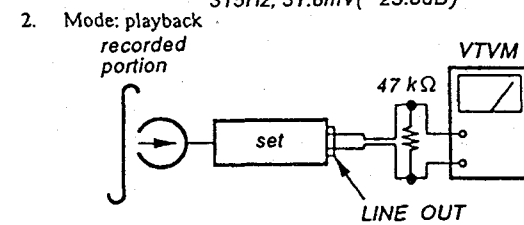
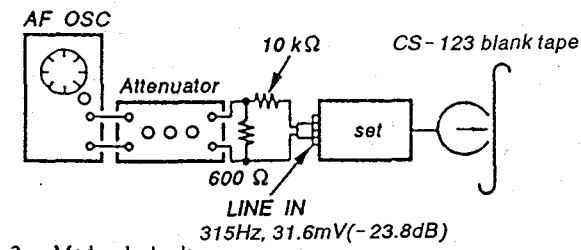

2. Mode: playback
 recorded portion

3. Playback the signal recorded in step 1.
 Confirm that the signal level is within the adjustment limits below. If necessary, adjust RV141 (L-ch) and RV241 (R-ch) repeat the step 1 - 2.

Adjustment Limits: $-23.8\text{dB} \pm 0.5\text{dB}$ (29 to 33.4mV)

Adjustment Location: MAIN board

Record EQ (IV) Adjustment

Setting:
 REC LEVEL control: Standard Record (See page 11)
 test pin CNE702 : short

Procedure:
 1. Mode: record

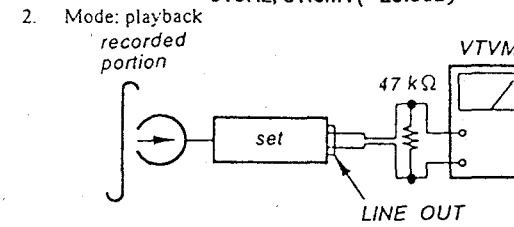
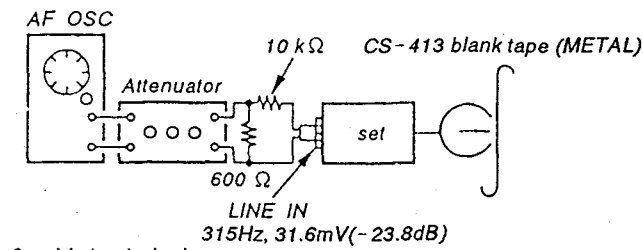

2. Mode: playback
 recorded portion

3. Playback the signal recorded in step 1.
 Adjust RV508 so that the R-channel meet the specification.

Adjustment Limits:

1. 10KHz level difference against 315Hz reference.
 $0\text{dB} \pm 0.5\text{dB}$

Adjustment Location: MAIN board

Adjustment Location

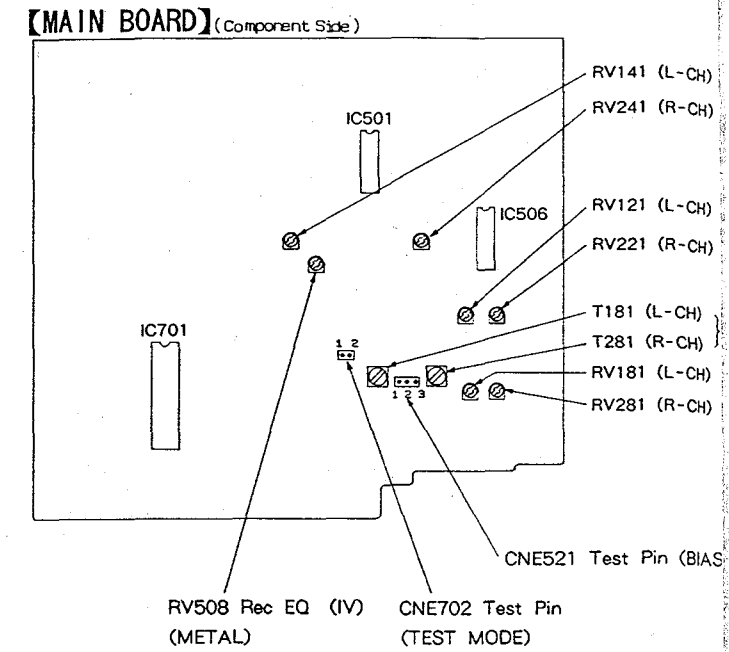

ent Location

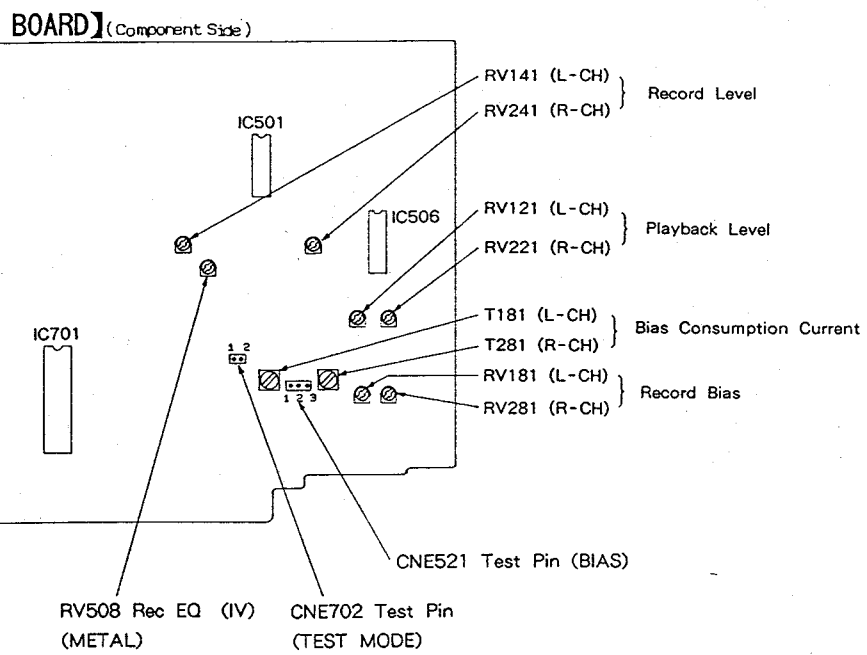

SECTION 5 DIAGRAMS

5-1. CIRCUIT BOARDS LOCATION

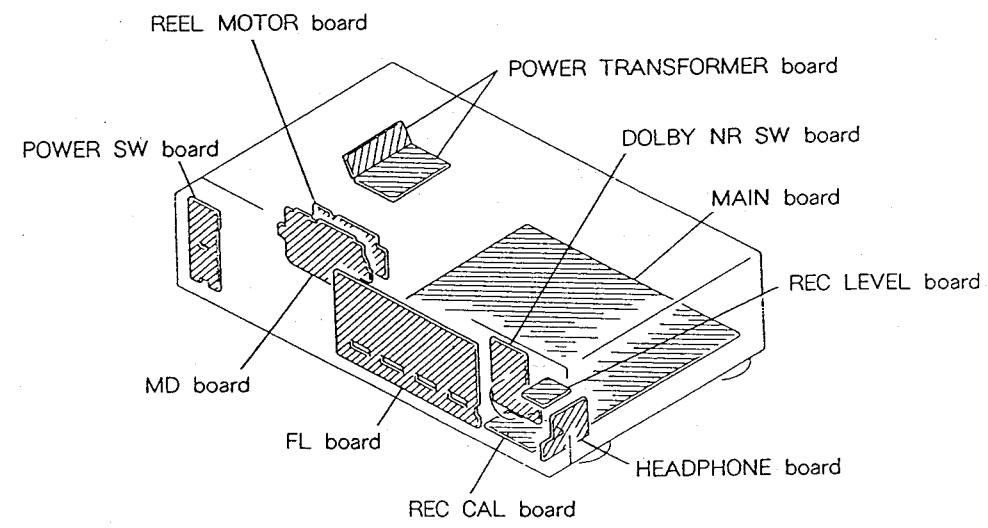

5-2. IC BLOCK DIAGRAM

- IC703 BA6219B
- IC704 LB1641

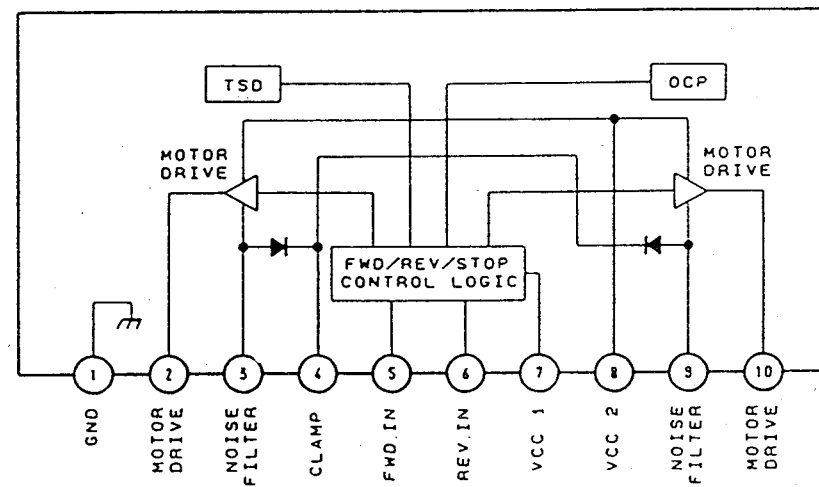



• Semiconductor Location



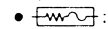

Ref. No.	Location	Ref. No.	Location	Ref. No.	Location	Ref. No.	Location
D101	D-3	D752	B-17	IC751	B-14	Q708	C-9
D102	E-3	D801	B-4	IC801	C-3	Q709	A-10
D201	E-3	D802	B-4	IC1001	C-23	Q710	C-7
D202	E-3	D803	B-4	IC1002	C-24	Q711	B-10
D501	G-3	D804	B-4			Q712	C-7
D502	F-7	D805	C-3	Q101	I-3	Q713	C-8
D503	F-7	D806	D-3	Q102	G-6	Q714	A-10
D504	F-3	D807	B-5	Q103	I-7	Q715	D-11
D505	F-3	D812	B-5	Q201	H-3	Q716	D-11
D506	F-7	D813	B-5	Q202	H-6	Q717	B-7
D507	F-7	D814	C-5	Q203	J-7	Q718	B-7
D508	F-7	D815	B-5	Q501	F-3	Q719	C-10
D509	J-10	D816	B-3	Q502	F-3	Q720	D-10
D510	G-10	D817	B-3	Q503	G-3	Q721	D-10
D511	G-10	D818	C-5	Q504	I-4	Q722	D-10
D512	D-6	D819	D-5	Q505	D-6	Q723	E-10
D513	E-6	D820	B-5	Q506	J-10	Q724	E-10
D514	E-6	D822	B-5	Q507	J-9	Q725	E-9
D515	E-6	D823	B-4	Q508	G-10	Q726	E-10
D516	F-10	D1051	C-29	Q509	G-11	Q727	D-9
D701	E-8			Q510	G-11	Q729	E-10
D702	E-8	IC501	G-4	Q511	G-10	Q801	C-3
D703	B-7	IC502	I-4	Q512	G-9	Q802	C-3
D704	B-7	IC503	H-7	Q513	F-6	Q803	C-2
D705	A-7	IC504	H-9	Q514	F-6	Q804	D-2
D706	C-9	IC505	J-8	Q515	F-6	Q805	D-5
D707	C-8	IC506	J-6	Q516	E-6	Q806	D-5
D708	D-7	IC507	I-19	Q517	F-11	Q807	B-3
D709	D-7	IC508	D-6	Q701	E-8	Q808	B-2
D712	E-9	IC509	E-3	Q702	D-9	Q809	B-3
D713	E-10	IC510	G-3	Q703	D-8	Q810	C-4
D714	D-10	IC701	B-10	Q704	E-8	Q811	D-4
D715	D-10	IC702	E-9	Q705	B-6		
D718	D-10	IC703	B-6	Q706	B-6		
D751	B-17	IC704	A-6	Q707	C-9		

Note on Schematic Diagram :



- All capacitors are in μF unless otherwise noted. pF: μpF 50WV or less are not indicated except for electrolytics and tantalums.
- All resistors are in Ω and $\frac{1}{2}$ W or less unless otherwise specified.
-  : fusible resistor.

Note:
The components identified by mark  or dotted line with mark  are critical for safety. Replace only with part number specified.

Note:
Les composants identifiés par une marque  sont critiques pour la sécurité. Ne les remplacer que par une pièce portant le numéro spécifié.

-  : B + Line
-  : B - Line
-  : adjustment for repair.
- Voltage and waveforms are dc with respect to ground under no-signal conditions.
no mark : PB
() : REC
- Voltages are taken with a VOM (input impedance 10 M Ω).
Voltage variations may be noted due to normal production tolerances.
- Waveforms are taken with an oscilloscope.
Voltage variations may be noted due to normal production tolerances.
- Signal path.
 : PB
 : REC

Note on Mounting Diagram :

-  : Parts extracted from the component side.
-  : Parts mounted on the conductor side.

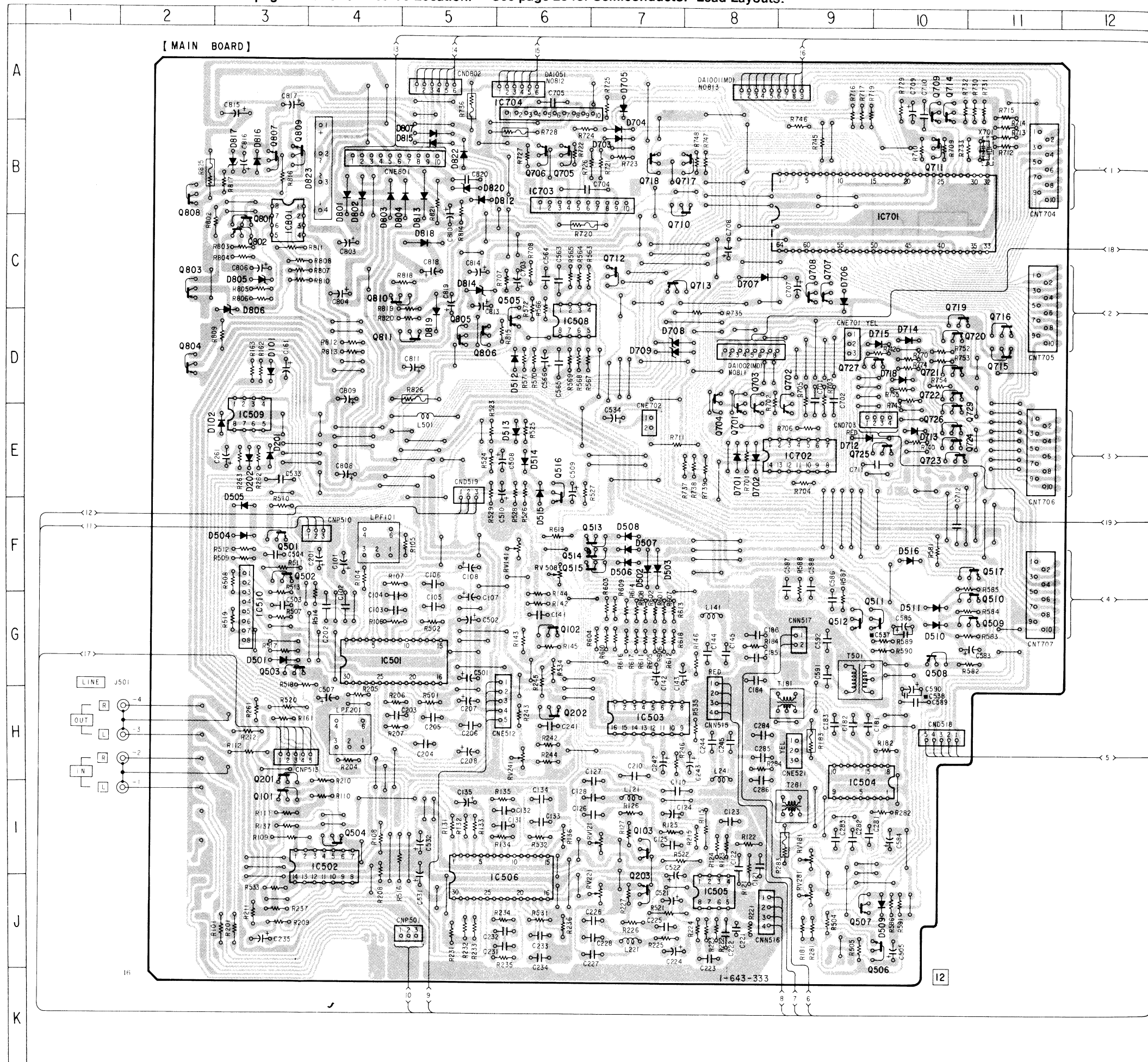

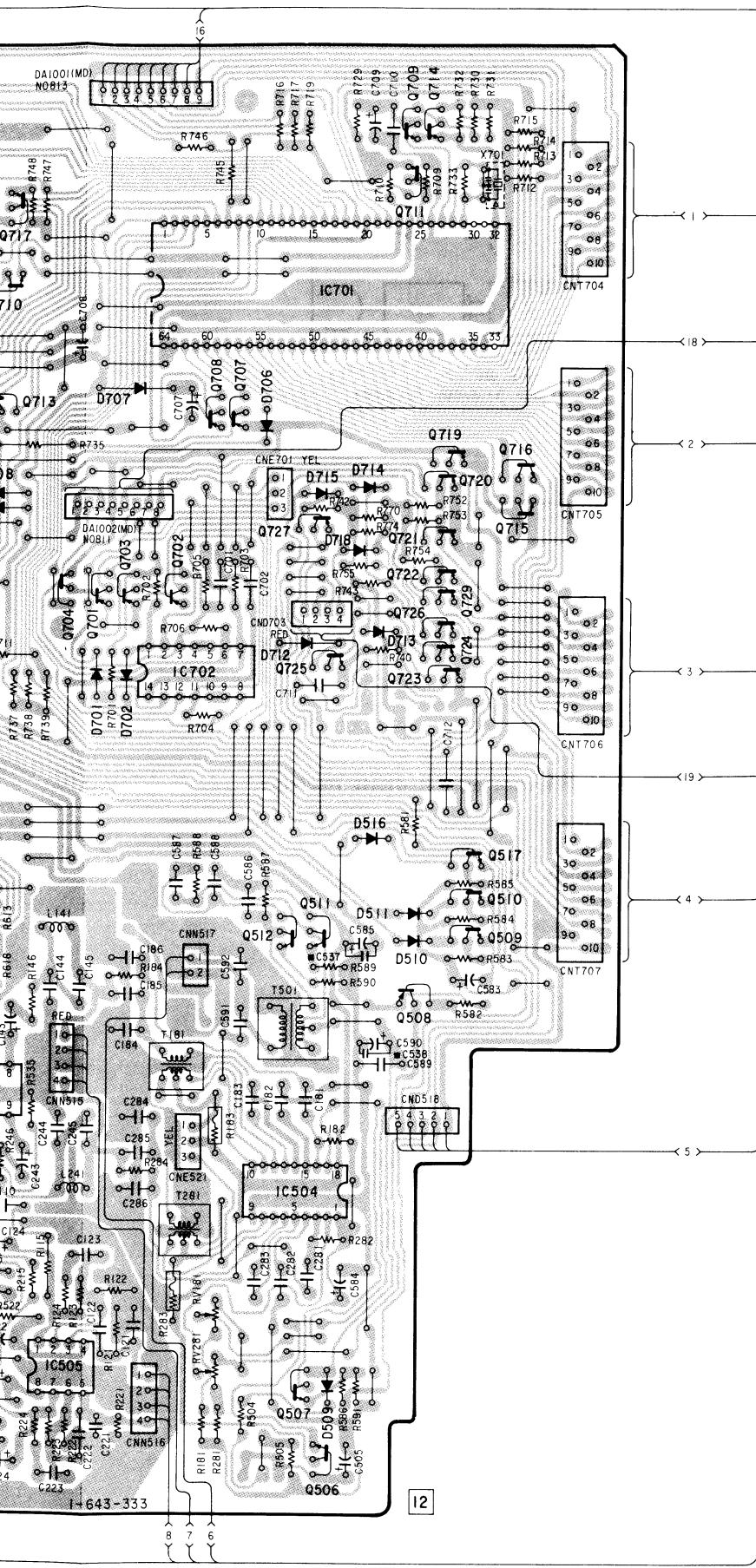

[DISPLAY BOARD]

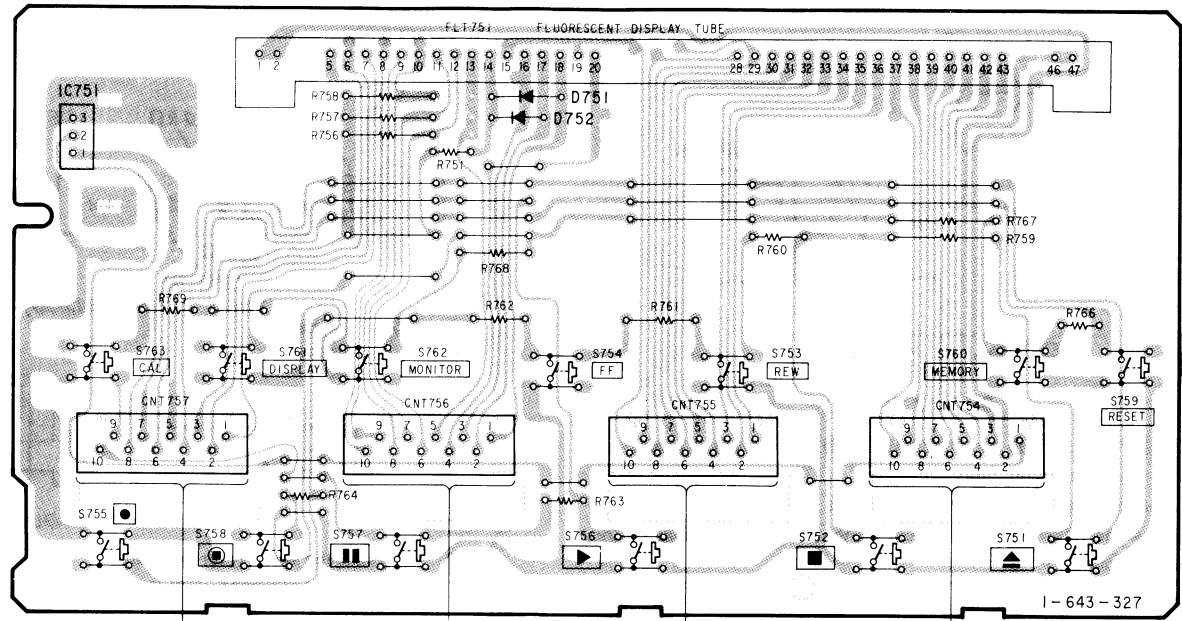

[MD BOARD]

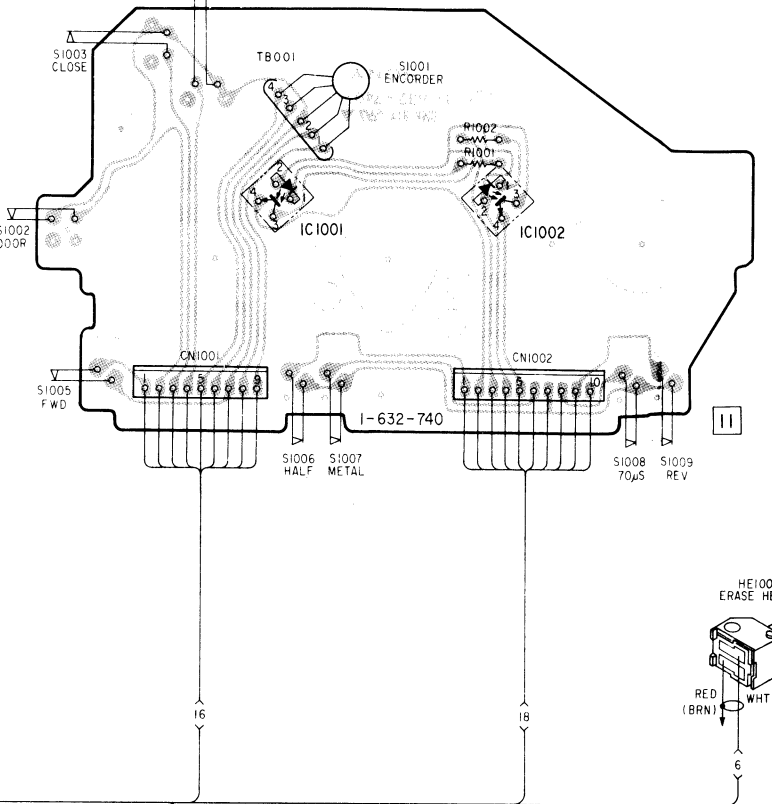

[DOLBY NR BOARD]

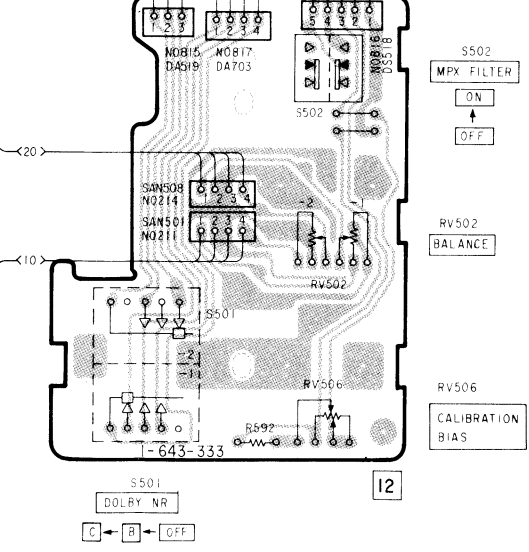

[REC CAL BOARD]

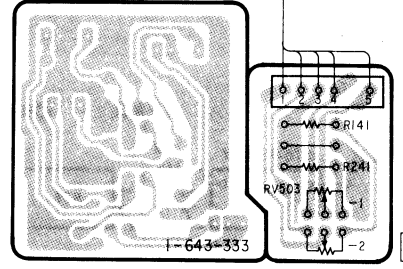

[REC LEVEL BOARD]

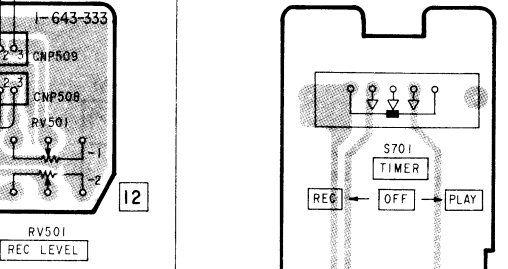

[HEADPHONE BOARD]

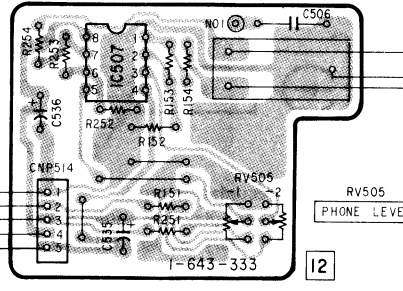

[PANEL BOARD]

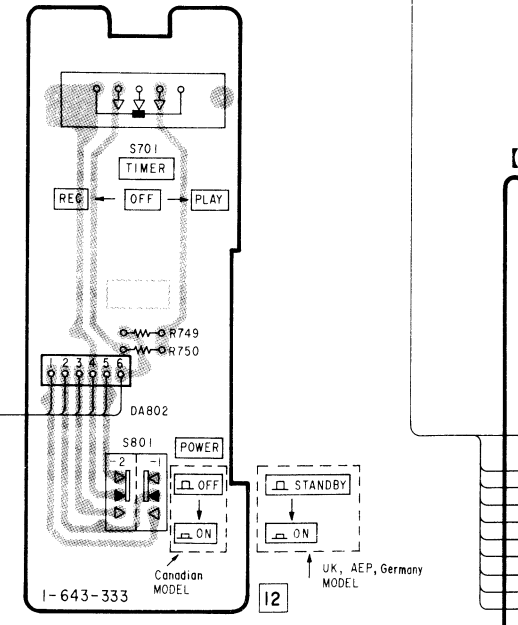

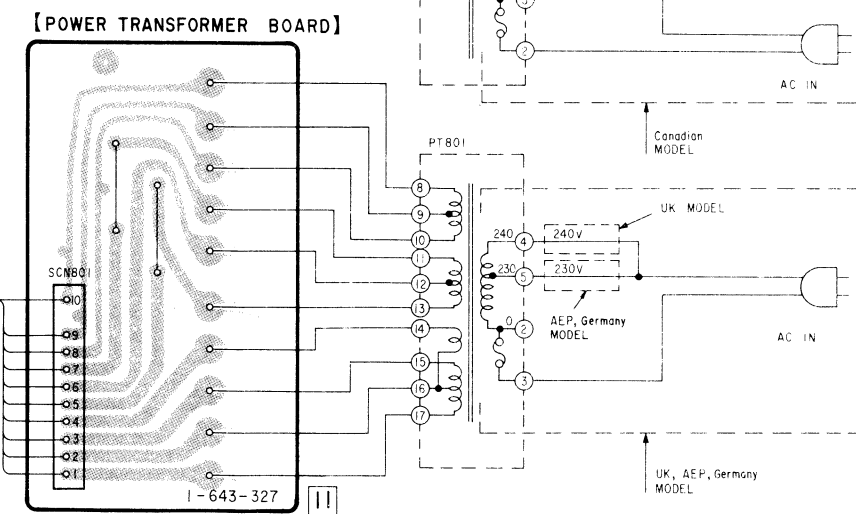
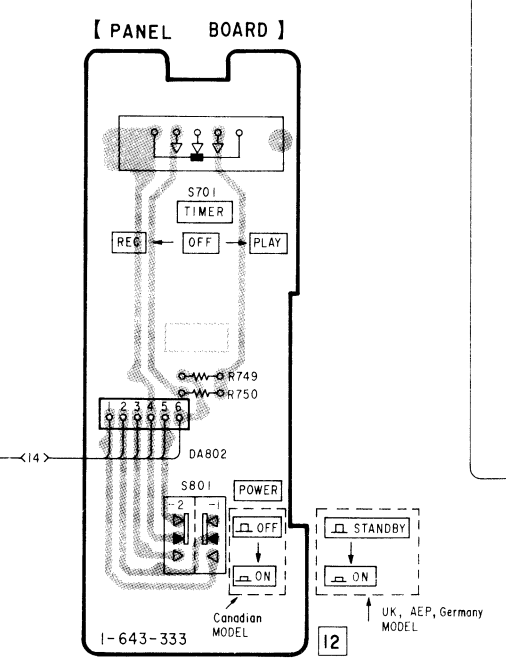
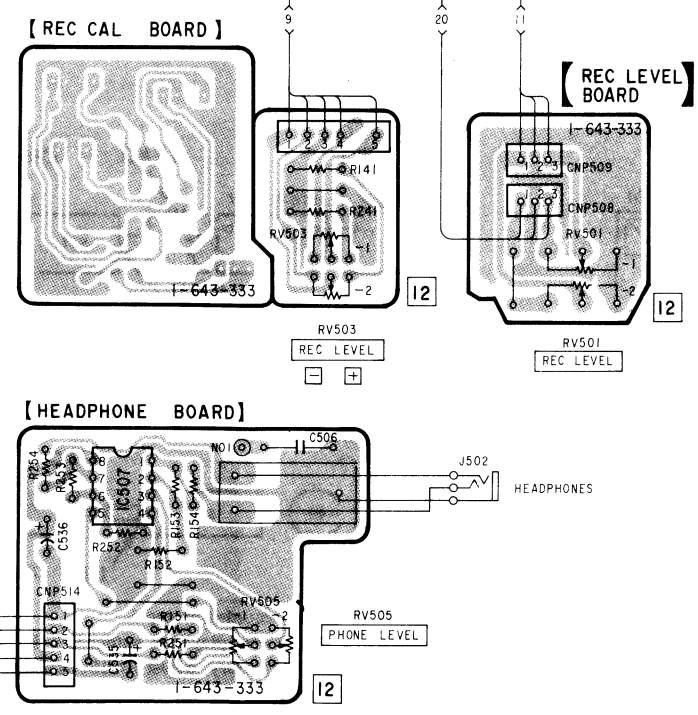
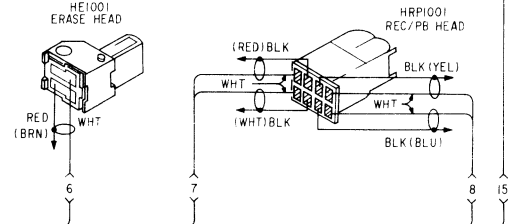
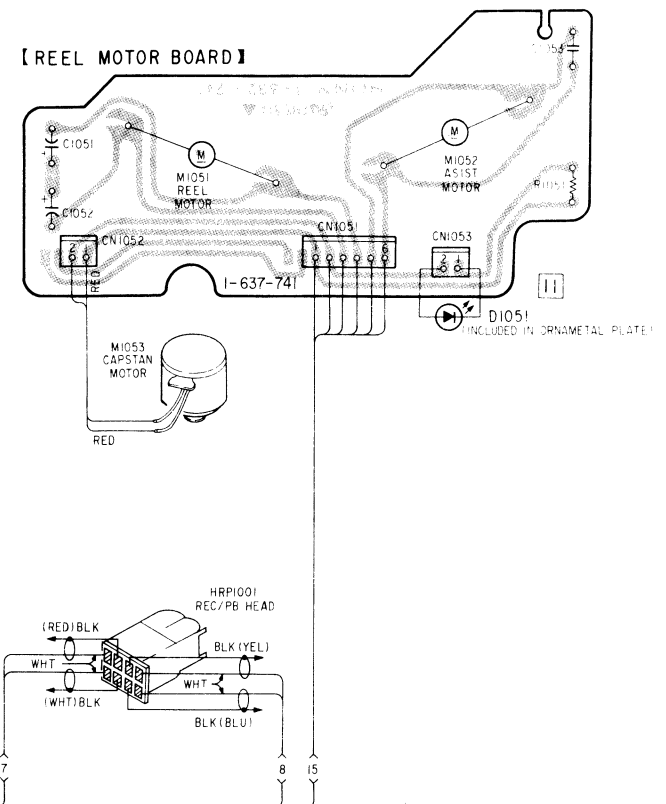
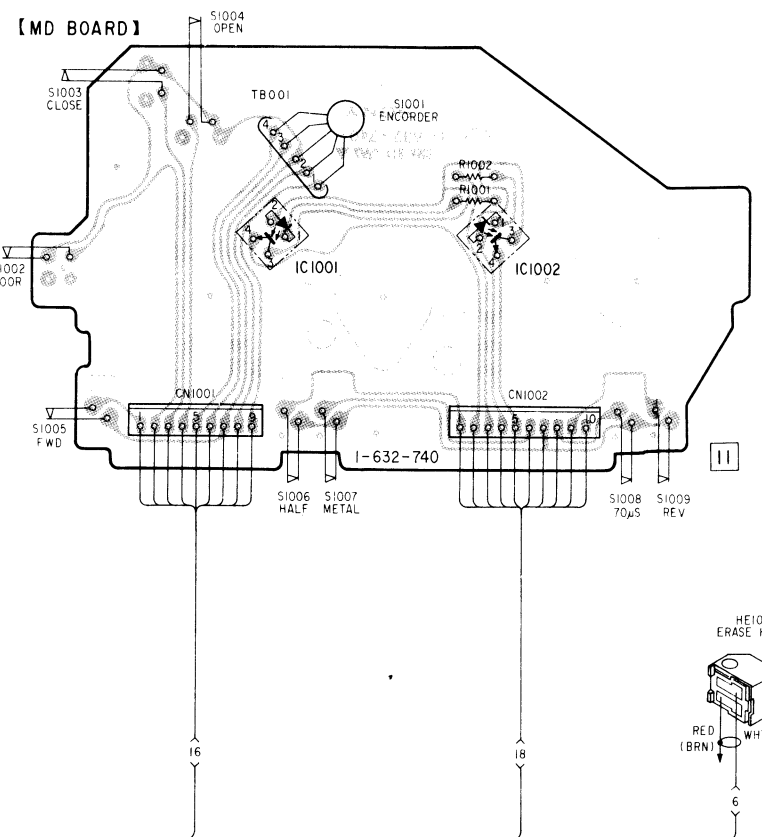
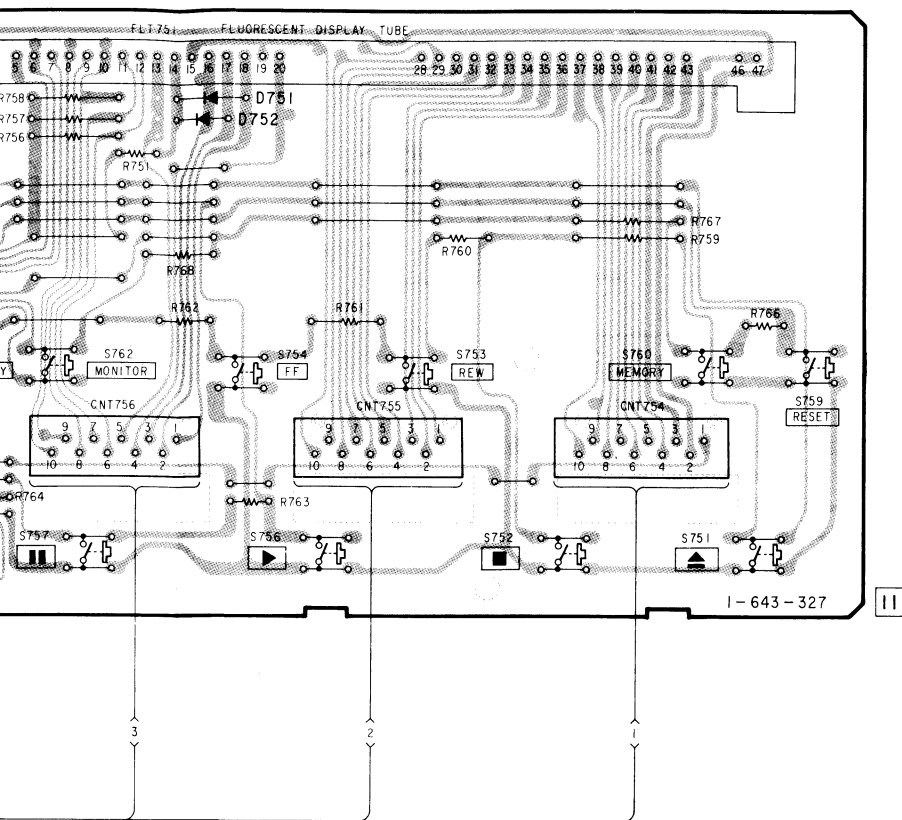

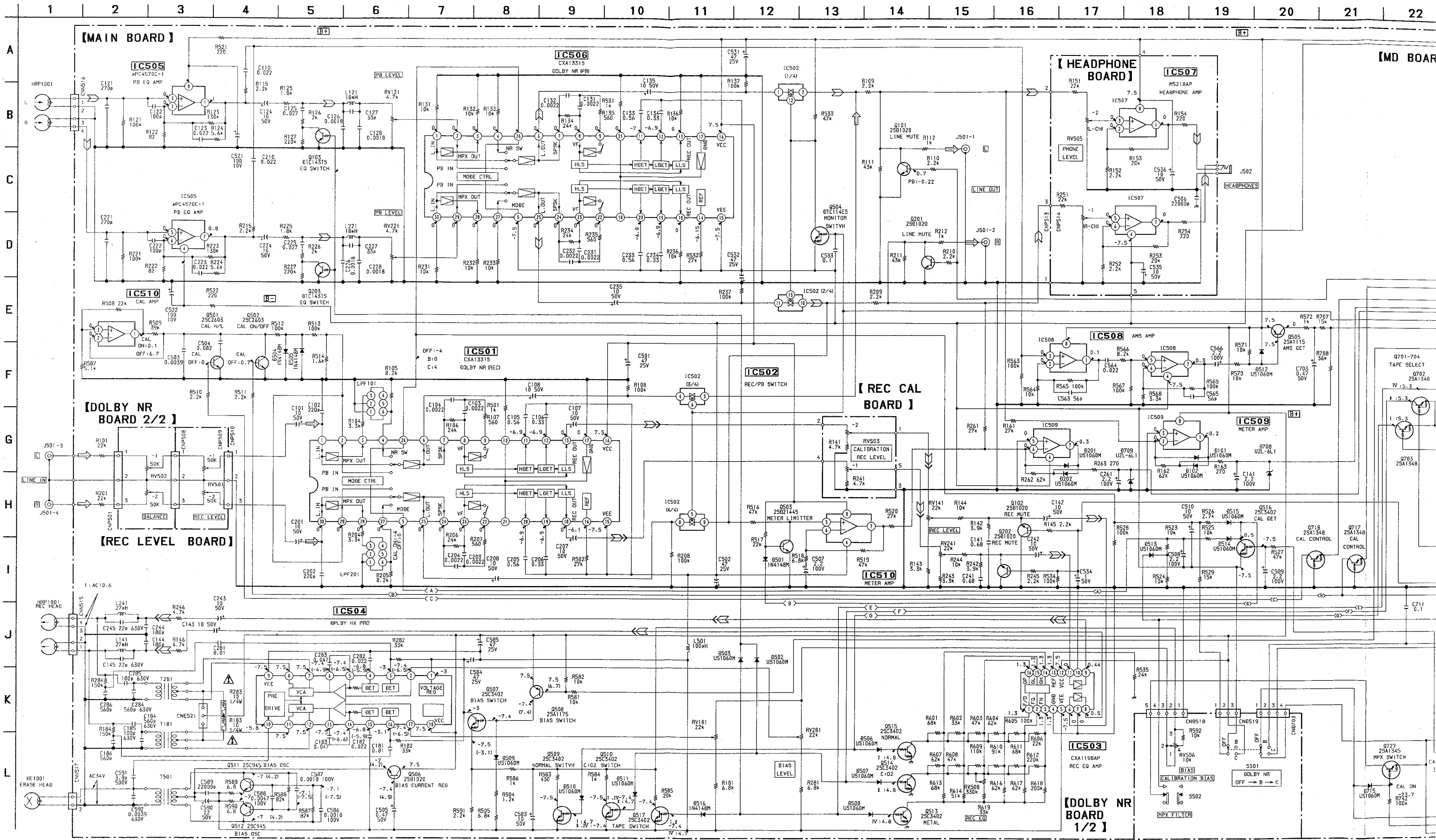

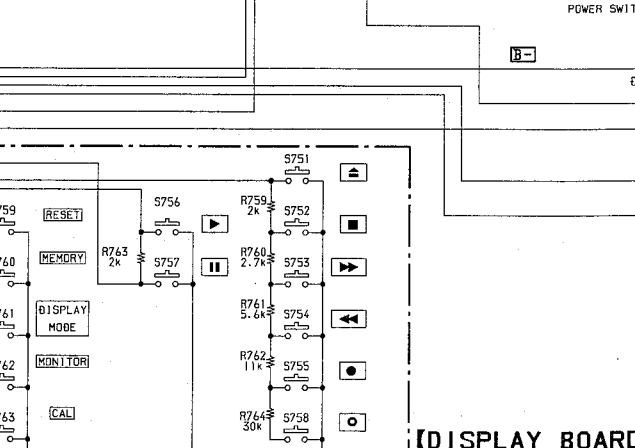
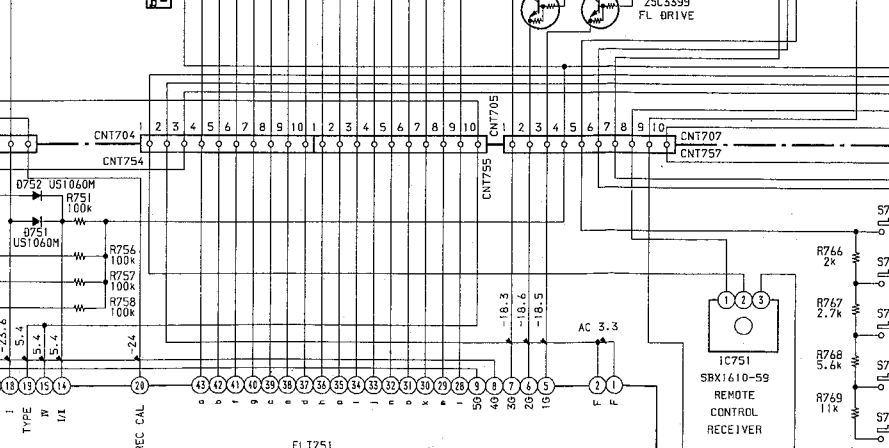
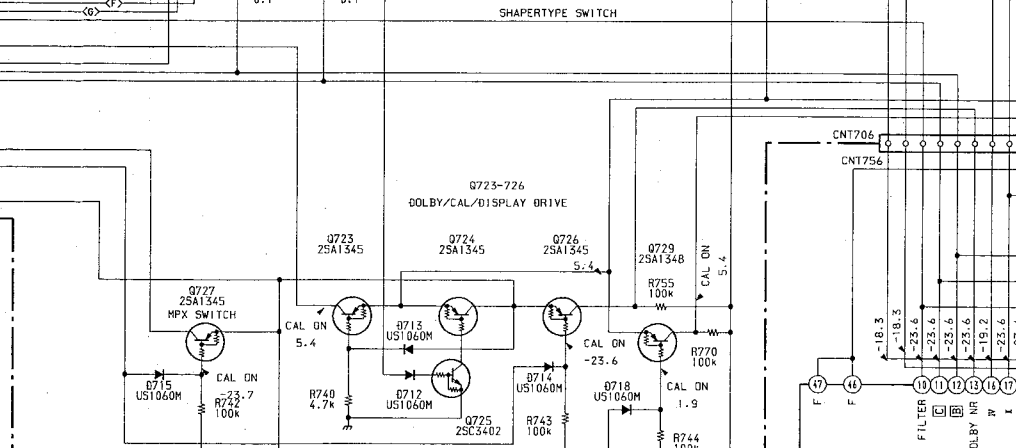
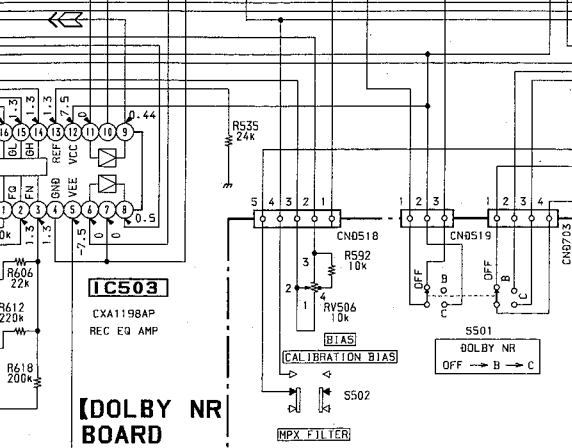
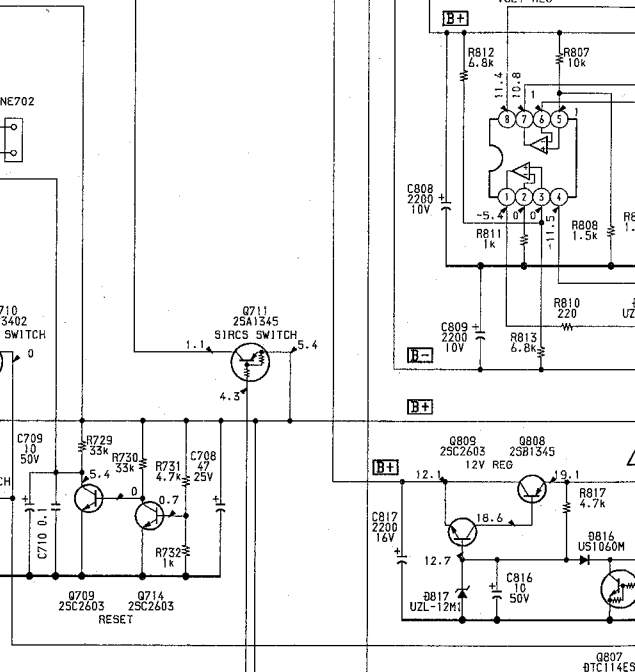
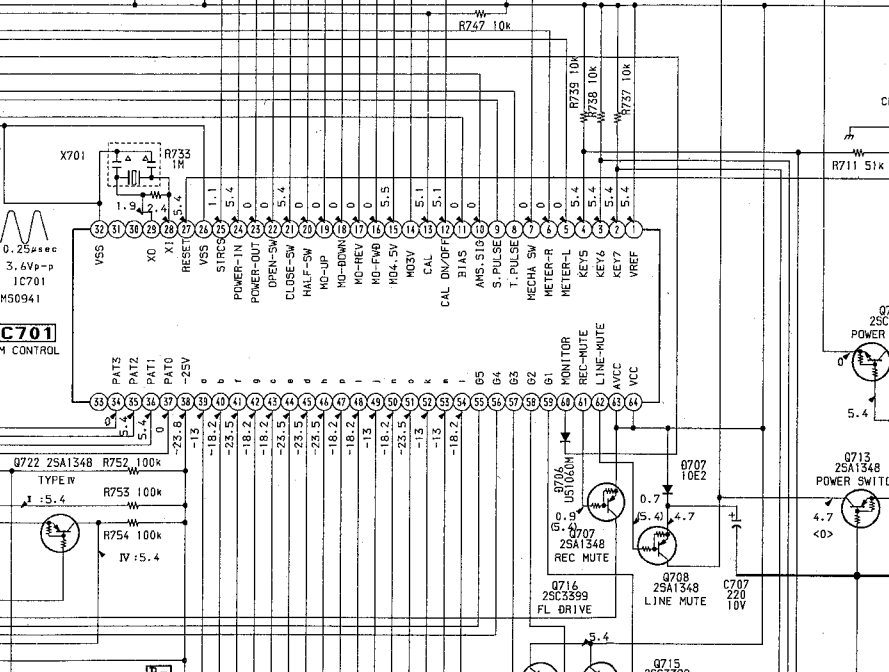
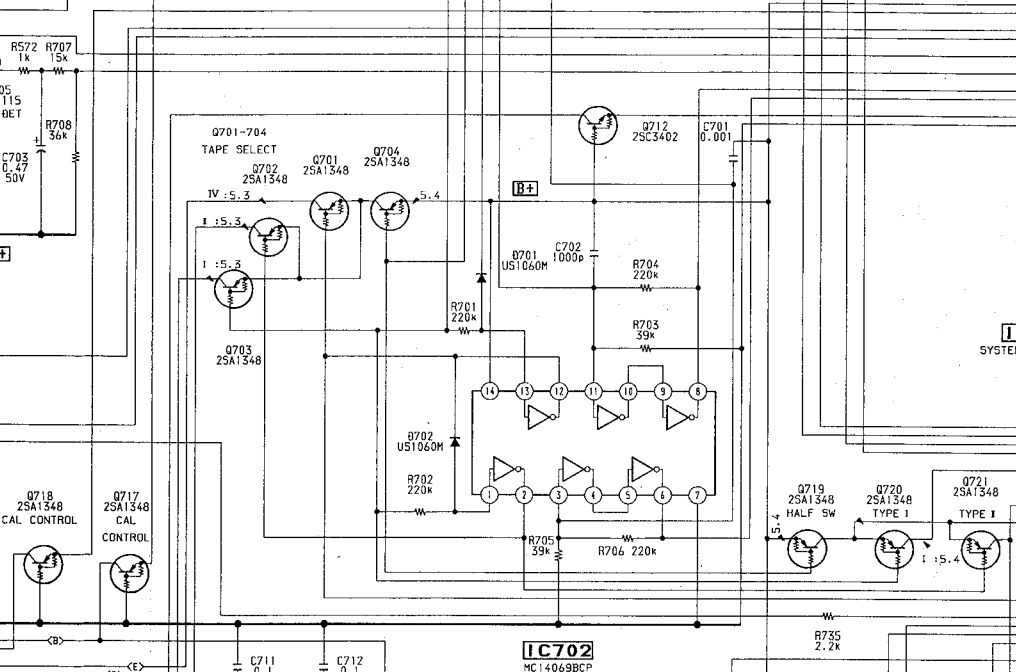
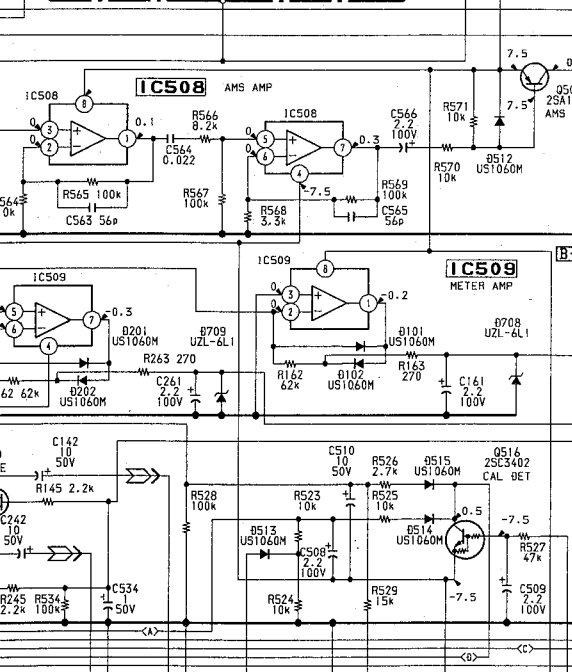
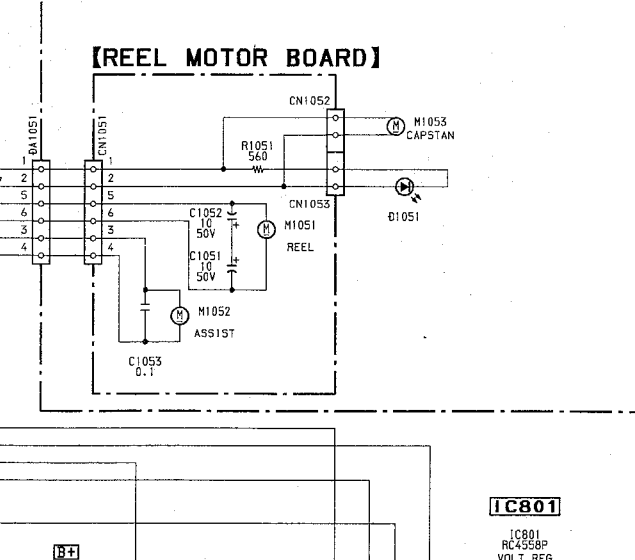
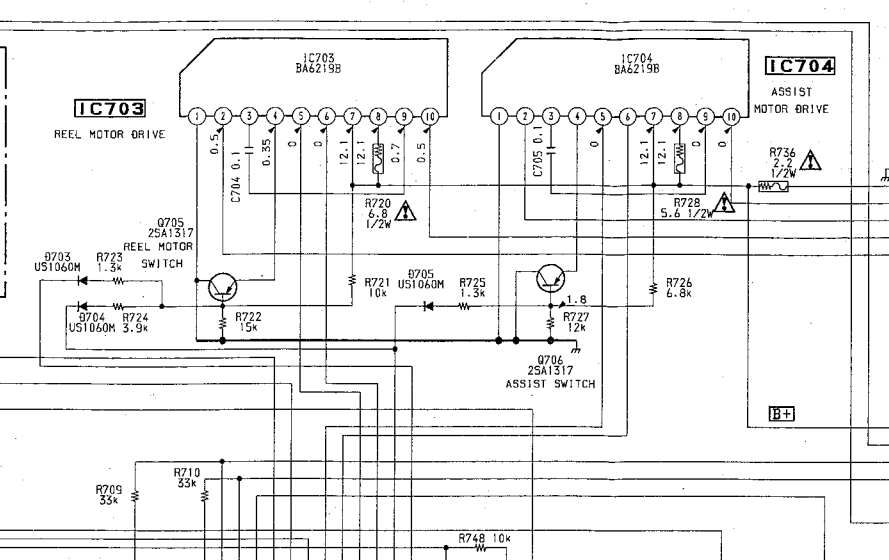
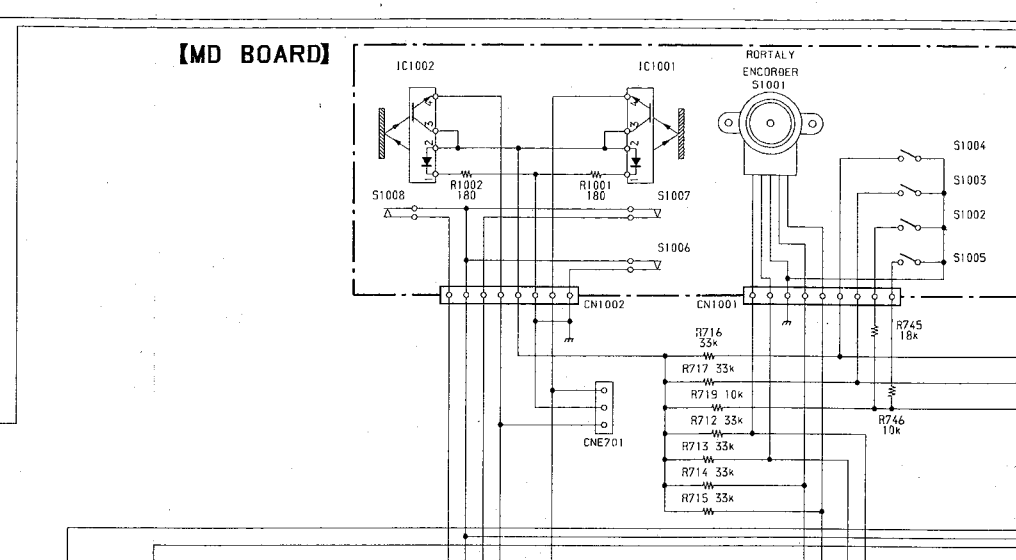
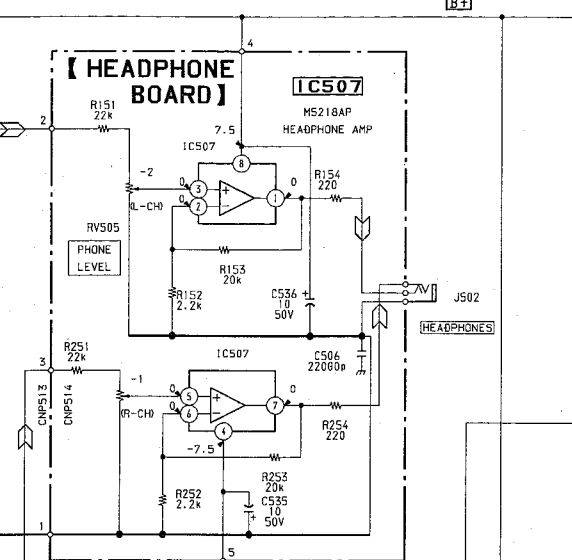

30 31 32 33 34 35 36 37 38 39 40 41 42 43 44 45

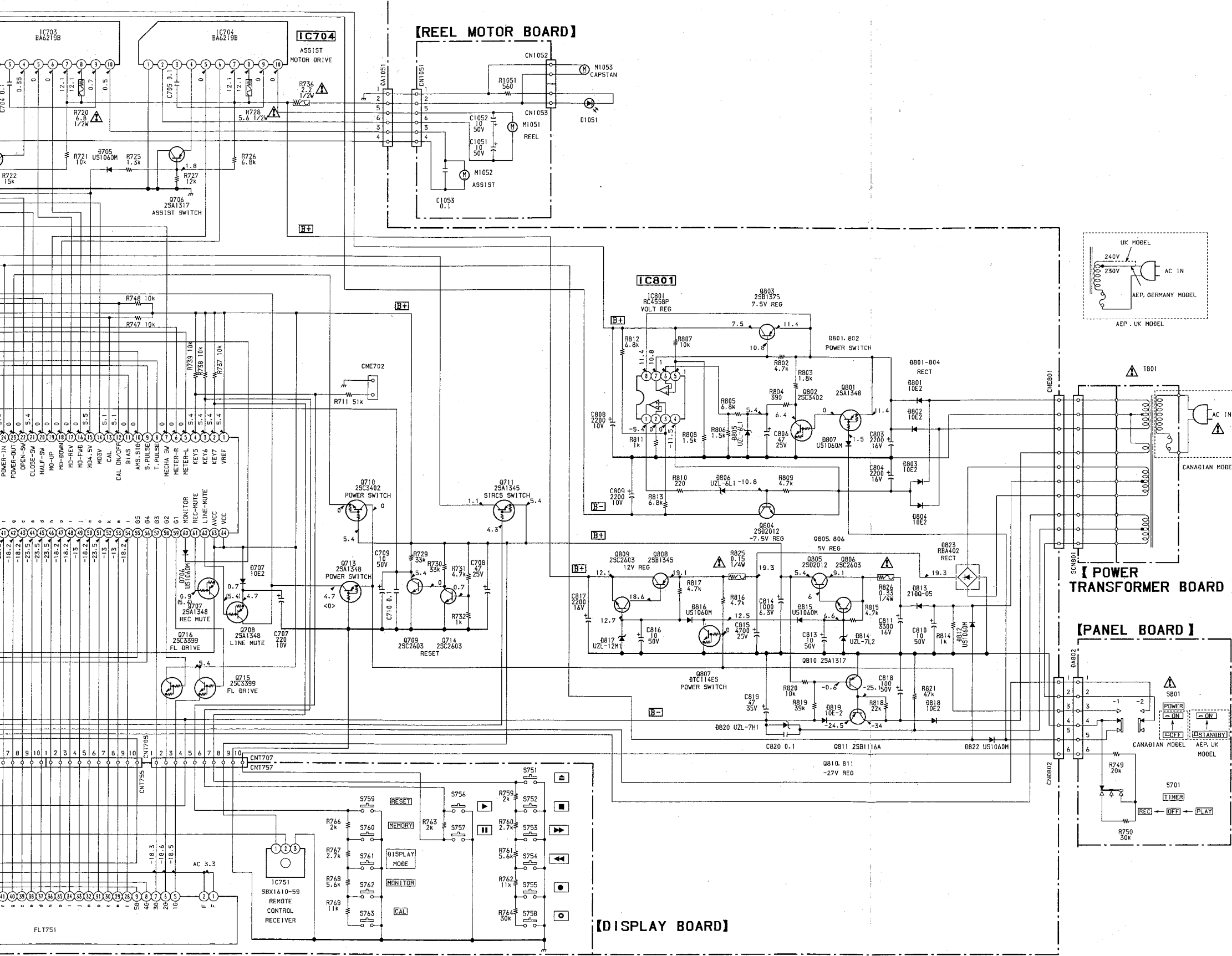

A B C D E F G H I J K L

30 31 32 33 34 35 36 37 38 39 40 41 42 43 44 45

A
B
C
D
E
F
G
H
I
J
K
L

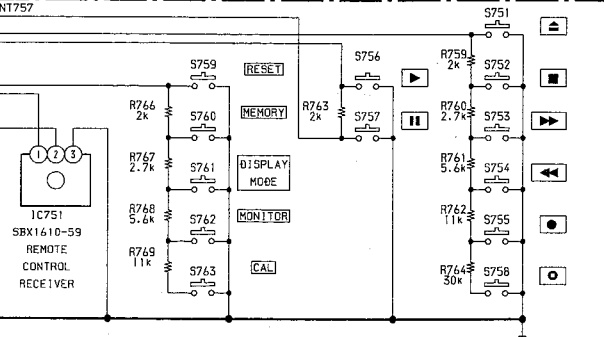
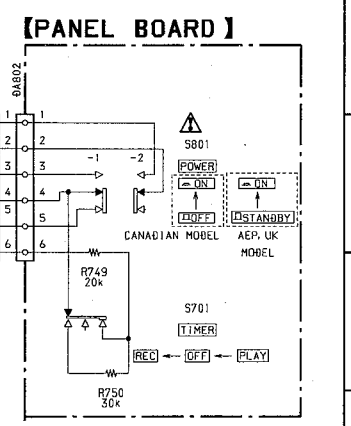
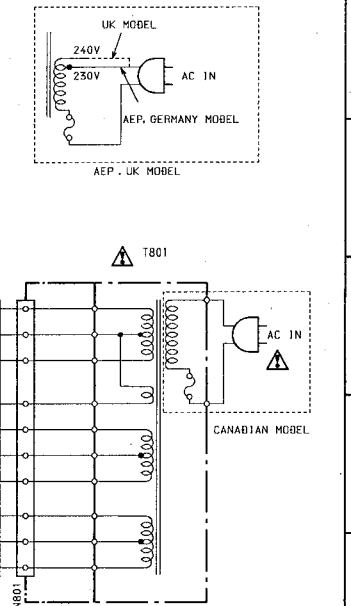
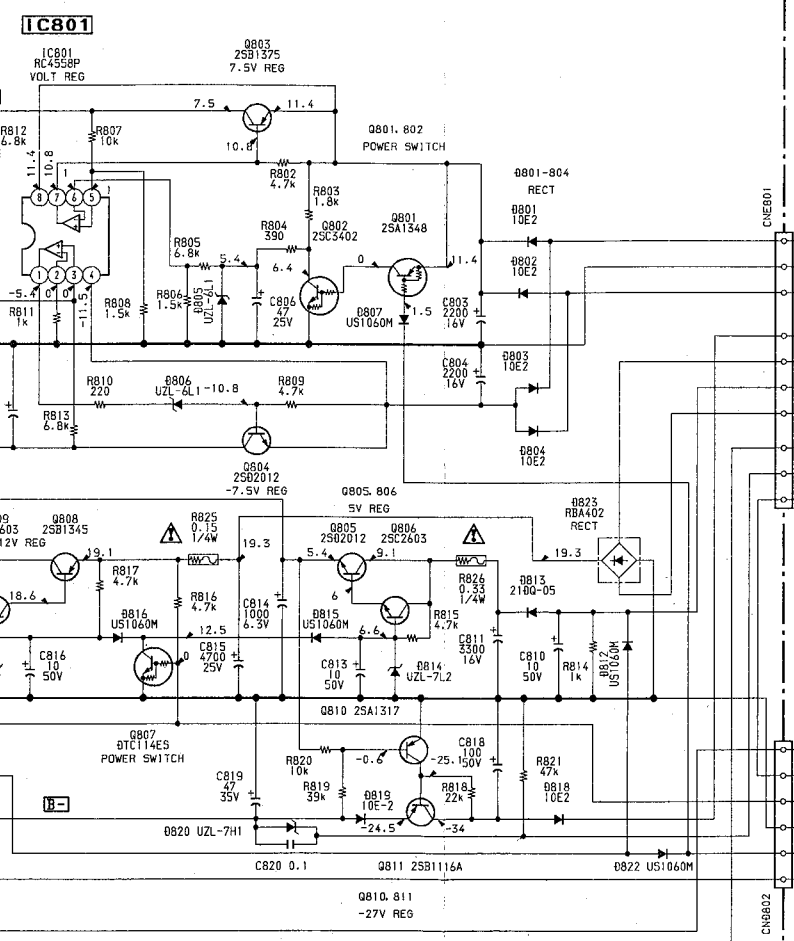
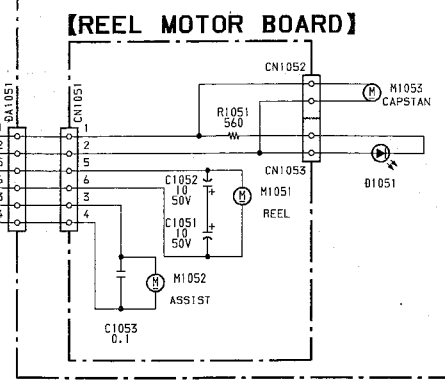
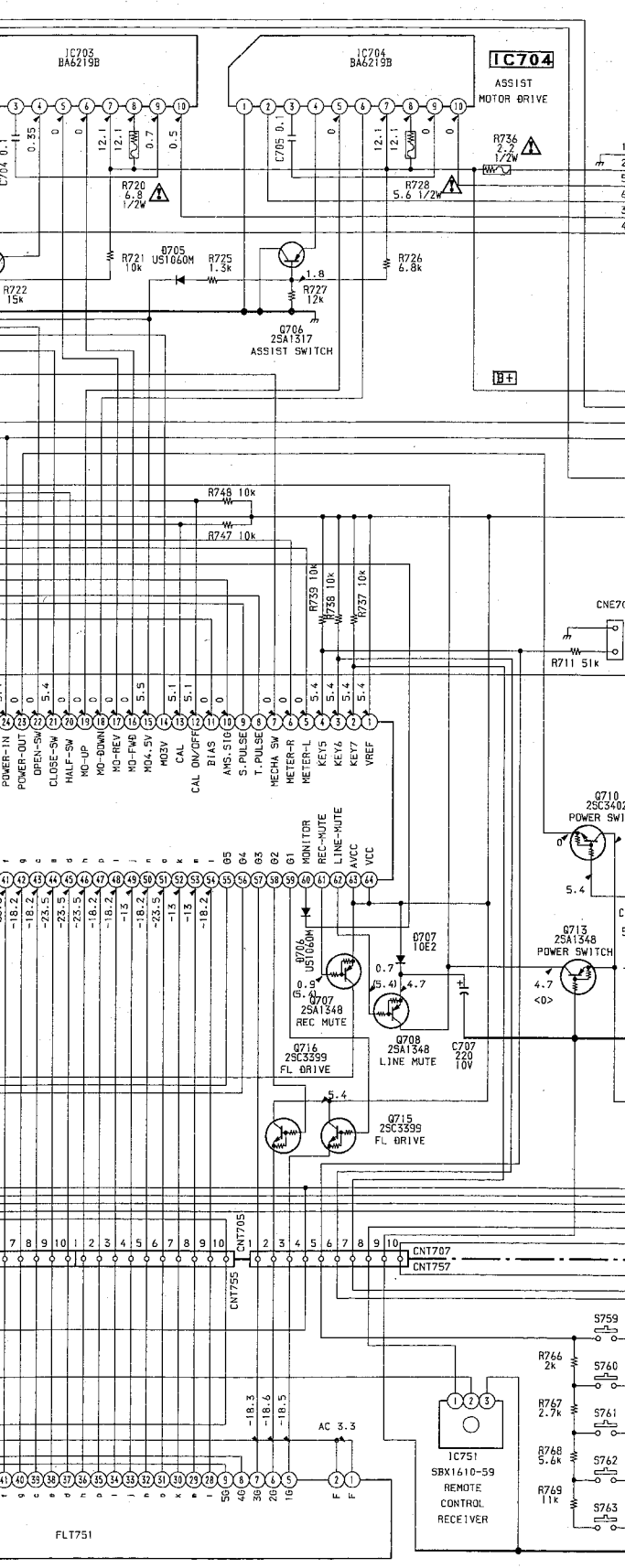

[DISPLAY BOARD]

SECTION 6
EXPLODED VIEWS

5-5. SEMICONDUCTOR LEAD LAYOUTS

BA6219B
LB1641

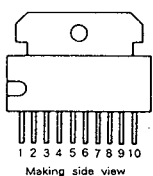

M5218AL

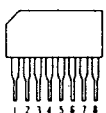

SBX1610-59

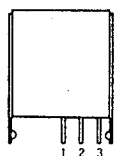

1 Vout
2 Vcc
3 GND

DTA114ES
DTA144ES
DTC114ES
DTC143TS
2SA1317-STU
2SC2603-EF
2SD2144S



DTC144ES
2SA1175-HFE

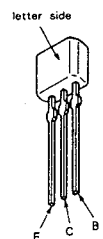

2SB1094-LK
2SD2012

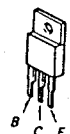

2SB1116A-L
2SC945-P

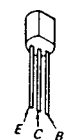

GP2S22B

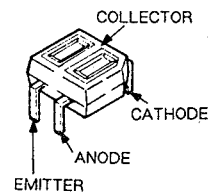

HZS6A1L
UZL-7L2

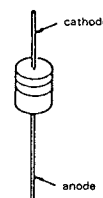

1N4148M
10E2N
21DQ05

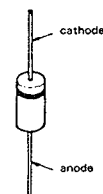

NOTE:

- XX, - X mean standardized parts, so they may have some differences from the original one.
- Color Indication of Appearance Parts
Example:
KNOB, BALANCE (WHITE)...(RED)
Parts color ↑ Cabinet's color ↑

- Items marked "*" are not stocked since they are seldom required for routine service. Some delay should be anticipated when ordering these items.
- The mechanical parts with no reference number in the exploded views are not supplied.
- Hardware (# mark) list is given in the last of this parts list.
- G: Germany model

The co
mark ▲
are cr
Replac
specifie

Les co
une ma
pour la s
Ne les
pièce po

6-1. CHASSIS SECTION

▲ B: POWER TRANSFORMER board

■ B-F: See next page

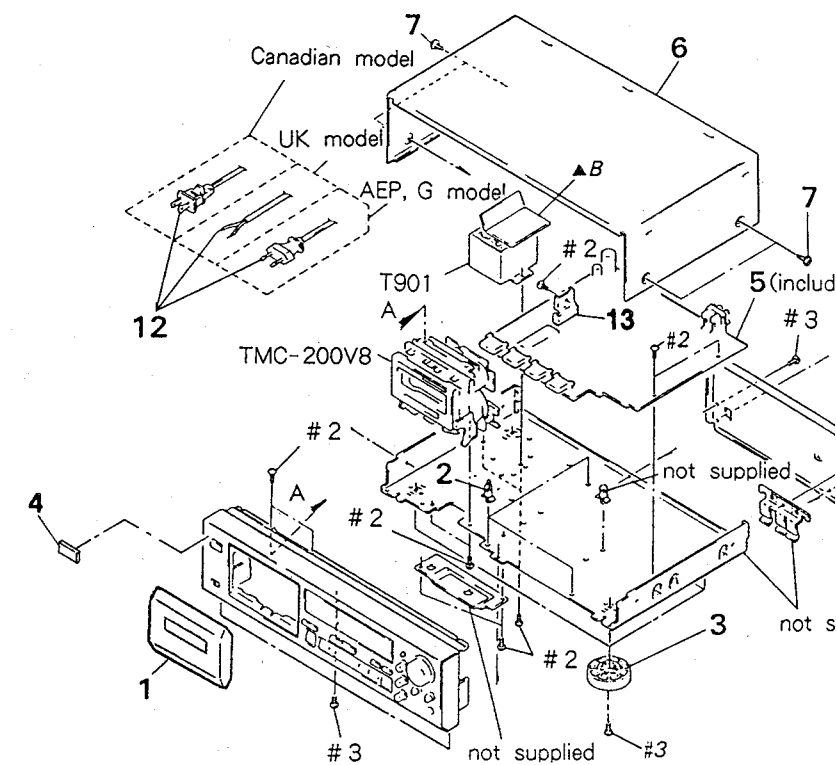

Ref. No.	Part No.	Description	Remarks	Ref. No.	Part No.	Description
1	X-3363-221-1	LID (A) ASSY, CASSETTE (Canadian)		* 8	3-375-667-11	PANEL, BACK (AEP)
1	X-3365-067-2	LID ASSY, CASSETTE (AEP, UK, Germany)		* 8	3-375-667-21	PANEL, BACK (UK)
* 2	3-346-265-11	HOLDER, PC BOARD		* 8	3-375-667-31	PANEL, BACK (Canadian)
3	4-943-148-32	FOOT (F58175SW) (Canadian)		* 10	3-703-244-00	BUSHING (2104), COR
3	4-943-148-42	FOOT (AEP, UK, Germany)		* 10	3-703-571-11	BUSHING (S) (4516)
4	4-908-848-01	EMBLEM, SONY		▲12	1-555-795-00	CORD, POWER, EULO P
* 5	A-2006-757-A	MAIN BOARD, COMPLETE		▲12	1-556-035-00	CORD, POWER (UK)
6	3-332-578-61	CASE		▲12	1-558-945-11	CORD, POWER (POLAR)
7	3-704-366-01	SCREW (CASE) (M3X8)		* 13	3-356-925-01	HEAT SINK
* 8	3-375-667-01	PANEL, BACK (AEP, Germany)		▲T901	1-450-100-11	TRANSFORMER, POWER
				▲T901	1-450-399-11	TRANSFORMER, POWER

SECTION 6 EXPLODED VIEWS

Items marked with "*" are not stocked and are seldom required for routine service. Some delay should be expected when ordering these items.

Items marked with "▲" are critical parts with no reference in the exploded views are given in this parts list.

7 model

The components identified by mark ▲ or dotted line with mark ▲ are critical for safety. Replace only with part number specified.

Les composants identifiés par une marque ▲ sont critiques pour la sécurité. Ne les remplacer que par une pièce portant le numéro spécifié.

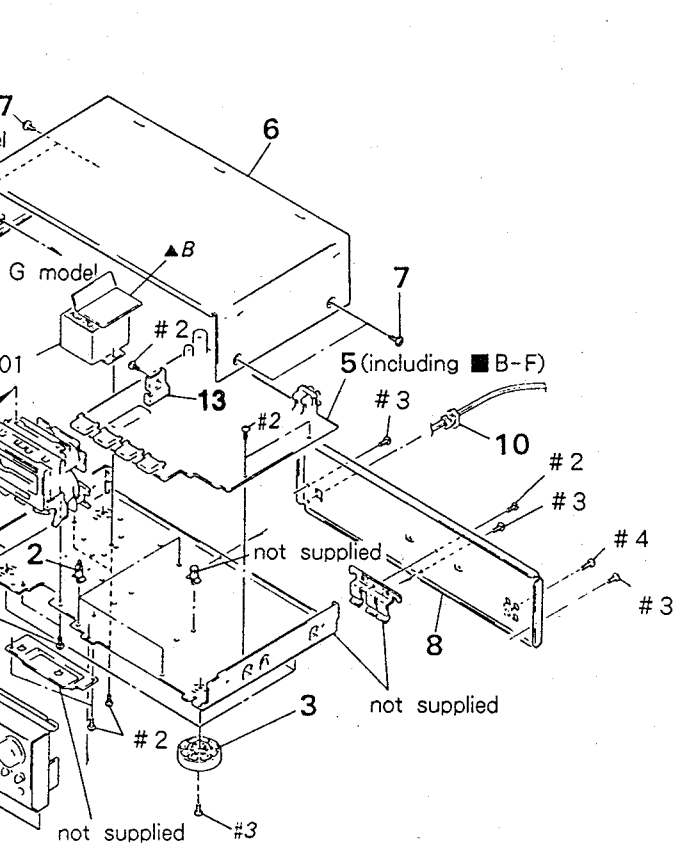

6-2. FRONT PANEL SECTION

- B : PANEL board
- C : DOLBY NR board
- D : REC LEVEL board
- E : HEADPHONE board
- F : REC CAL board

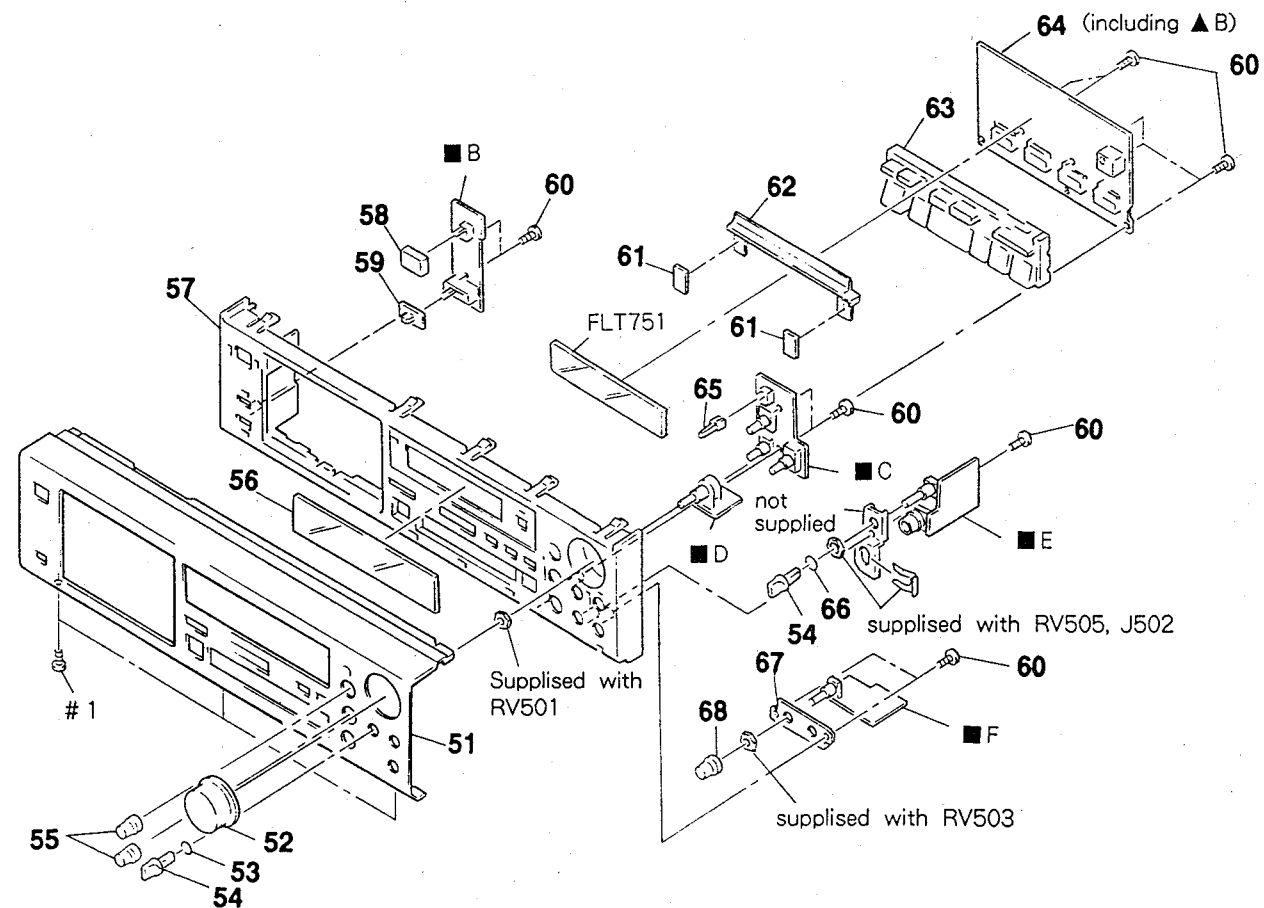

Ref. No.	Part No.	Description	Remarks
* 8	3-375-667-11	PANEL, BACK (AEP)	
* 8	3-375-667-21	PANEL, BACK (UK)	
* 8	3-375-667-31	PANEL, BACK (Canadian)	
* 10	3-703-244-00	BUSHING (2104), CORD (AEP, UK, Germany)	
* 10	3-703-571-11	BUSHING (S) (4516), CORD (Canadian)	
▲12	1-555-795-00	CORD, POWER, EULO PLUG (AEP, Germany)	
▲12	1-556-035-00	CORD, POWER (UK)	
▲12	1-558-945-11	CORD, POWER (POLAR.SPT-1) (Canadian)	
* 13	3-356-925-01	HEAT SINK	
▲T901	1-450-100-11	TRANSFORMER, POWER (Canadian)	
▲T901	1-450-399-11	TRANSFORMER, POWER (AEP, UK, Germany)	

Ref. No.	Part No.	Description	Remarks
51	3-379-229-21	PANEL, FRONT (AEP, UK, Germany)	
51	3-379-229-31	PANEL, FRONT (Canadian)	
52	3-367-438-11	KNOB (REC)	
53	3-370-186-01	SPRING (SWPA), RING	
54	3-350-495-01	KNOB (VOL)	
55	3-367-431-01	KNOB (BAL)	
56	3-367-433-11	WINDOW (METER) (Canadian)	
56	3-378-144-11	WINDOW (METER) (AEP, UK, Germany)	
57	3-367-440-01	PANEL (BASE)	
58	4-922-921-01	BUTTON (POWER)	

Ref. No.	Part No.	Description	Remarks
59	4-931-421-11	KNOB (T & S)	
60	4-928-635-01	SCREW, +BV (2.6X8) TAPPING	
61	9-911-844-XX	CUSHION	
* 62	4-932-502-01	HOLDER, FL TUBE	
63	3-368-281-31	BUTTON (B)	
* 64	1-643-327-11	DISPLAY BOARD	
65	3-350-473-01	BUTTON (MPX)	
66	3-356-957-01	SPRING	
* 67	3-368-280-01	BRACKET (C)	
68	3-370-003-01	KNOB (BAL)	
FLT751 1-519-710-11 INDICATOR TUBE, FLUORESCENT			

6-3. MECHANISM SECTION 1 (TCM-200V8)

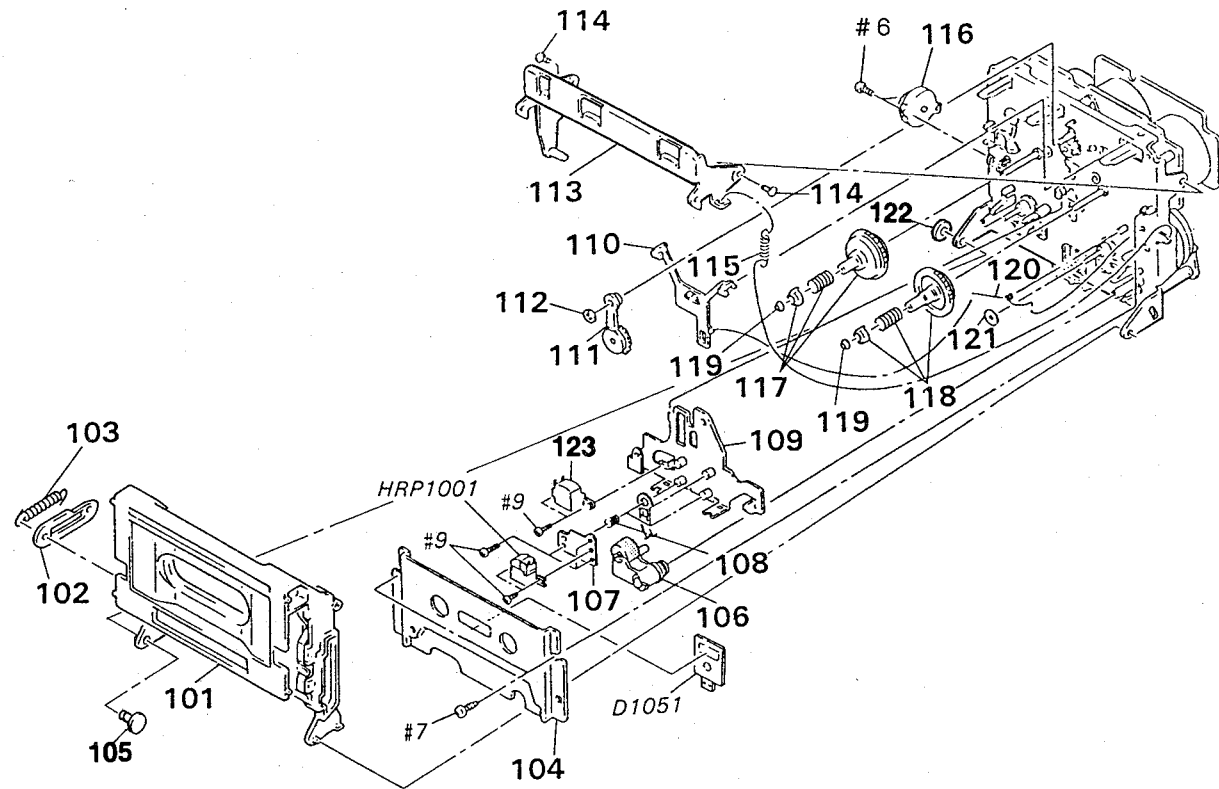

Ref. No.	Part No.	Description
101	X-3364-799-1	HOLDER (CD) (2) ASSY, CASSETTE
* 102	3-356-717-01	LEVER (JOINT)
103	3-356-626-01	SPRING, TENSION
104	X-3356-613-1	PLATE ASSY, ORNAMENTAL
105	3-378-341-01	SHAFT (L) (CASSETTE HOLDER)
106	X-3356-649-1	LEVER (PINCH LEVER T) ASSY
* 107	3-356-742-01	BRACKET (GUIDE R)
108	3-356-659-01	SPRING (RPH), COMPRESSION
109	X-3356-648-1	SLIDER (HEAD CHASSIS V2) ASSY
110	3-356-614-01	SLIDER (BRAKE)
111	X-3356-641-1	LEVER (FR2) ASSY
112	3-669-465-11	WASHER (1.5), STOPPER

Ref. No.	Part No.	Description
* 113	X-3356-608-1	LEVER (LIFTER) ASSY
114	3-356-601-11	SCREW, STEP
115	3-356-625-01	SPRING, TENSION
116	3-712-786-01	DAMPER, OIL
117	X-3356-628-1	GEAR (S) ASSY
118	X-3356-627-1	GEAR (T) ASSY
119	3-362-308-01	CAP (REEL)
D1051	8-719-980-85	DIODE SLF325C
120	3-356-619-01	SPRING (B), TORSION
121	3-356-713-01	WASHER
122	3-558-708-21	WASHER, STOPPER
123	1-543-673-11	HEAD, MAGNETIC (ERASE)
HRP1001	1-543-673-11	HEAD, MAGNETIC (RECORD/PLAYBACK)

6-4. MECHANISM SECTION 2 (TCM-200V8)

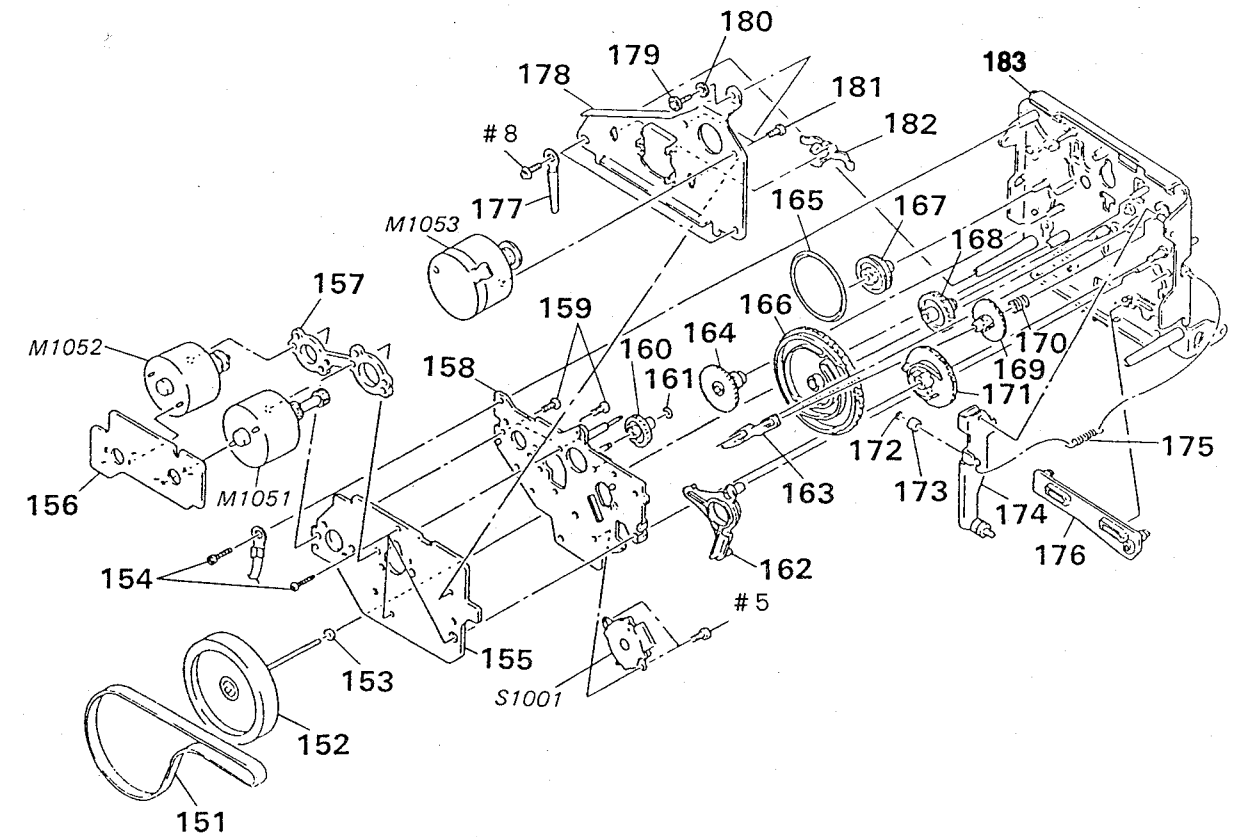

Ref. No.	Part No.	Description
151	3-356-744-01	BELT (CAPSTAN V)
152	X-3356-642-1	FLYWHEEL (R FWD) ASSY
153	3-356-705-01	WASHER (CAPSTAN)
154	3-355-801-01	SCREW (BTP 2X18)
* 155	1-632-740-11	MD BOARD
* 156	1-632-741-11	REAL MOTOR BOARD
* 157	3-356-628-01	SPACER (MOTOR)
* 158	X-3356-602-1	BRACKET (MOTOR R) ASSY
159	3-363-804-01	SCREW (+P 2.6X6.5)
160	3-356-702-01	GEAR (COMMUNICATION B)
161	3-669-465-00	WASHER (1.5), STOPPER
162	3-356-613-01	LEVER (MODE)
163	3-356-617-01	LEVER (SELECTION)
164	3-356-606-01	GEAR (MODE)
165	3-356-603-01	BELT (MODE)
166	3-356-747-01	GEAR (MODE CAM C)
167	3-356-607-01	PULLEY (MODE)
168	3-356-703-01	GEAR (COMMUNICATION C)
169	3-356-609-01	GEAR (LOADING)
170	3-356-605-01	SPRING, COMPRESSION

Ref. No.	Part No.	Description
171	3-356-616-01	GEAR (LOADING CAM)
172	3-558-708-11	WASHER, STOPPER
173	3-356-630-01	ROLLER (LOADING)
* 174	X-3356-606-1	LEVER (LOADING) ASSY
175	3-376-854-01	SPRING, TENSION
176	3-356-653-01	SLIDER (PAUSE)
177	3-703-150-11	STOPPER, WIRING
* 178	3-356-629-01	BRACKET (THRUST RETAINER R)
179	3-356-707-01	SCREW (+PTPWH 2X25)
* 180	3-356-718-01	SPACER (THRUST RETAINER R)
181	4-885-599-00	SCREW, FITTING, REINFORCEMENT
182	3-575-321-00	RETAINER, THRUST, CAPSTAN
183	X-3356-644-1	CHASSIS COMPLETE ASSY, MECH
M1051	X-3356-638-1	MOTOR (REEL R) ASSY
M1052	X-3356-604-1	MOTOR (ASSIST) ASSY
M1053	X-3356-646-1	MOTOR (CAPSTAN V1) ASSY
S1001	1-466-238-11	ENCODER, ROTARY

SECTION 7 ELECTRICAL PARTS LIST

DISPLAY MD

NOTE:

The components identified by mark Δ or dotted line with mark Δ are critical for safety. Replace only with part number specified.

Les composants identifiés par une marque Δ sont critiques pour la sécurité. Ne les remplacer que par une pièce portant le numéro spéci-fie.

When indicating parts by reference number, please include the board name.

- Due to standardization, replacements in the parts list may be different from the parts specified in the diagrams or the components used on the set.
- -XX, -X mean standardized parts, so they may have some difference from the original one.
- Items marked "*" are not stocked since they are seldom required for routine service. Some delay should be anticipated when ordering these items.
- CAPACITORS :
uF : μ F
- RESISTORS
All resistors are in ohms.
METAL : metal-film resistor
METAL OXIDE : Metal Oxide-film resistor
F : nonflammable
- COILS
uH : μ H
- SEMICONDUCTORS
In each case, u : μ , for example :
uA... : μ A..., uPA..., μ PA...,
uPB..., μ PB..., uPC..., μ PC...,
uPD..., μ PD...

Ref. No.	Part No.	Description	Remarks	Ref. No.	Part No.	Description	Remarks
*	1-643-327-11	DIPLAY BOARD *****				< SWITCH >	
	9-911-844-XX	CUSHION		S751	1-554-303-21	SWITCH, TACTILE (Δ)	
*	4-932-502-01	HOLDER, FL TUBE < CONNECTOR >		S752	1-554-303-21	SWITCH, TACTILE (\blacksquare)	
				S753	1-554-303-21	SWITCH, TACTILE (\blacktriangleright)	
* CNT754	1-580-782-11	CONNECTOR, BOARD TO BOARD		S754	1-554-303-21	SWITCH, TACTILE (\blacktriangleleft)	
* CNT755	1-580-782-11	CONNECTOR, BOARD TO BOARD		S755	1-554-303-21	SWITCH, TACTILE (\bullet)	
* CNT756	1-580-782-11	CONNECTOR, BOARD TO BOARD		S756	1-554-303-21	SWITCH, TACTILE (\blacktriangleright)	
* CNT757	1-580-782-11	CONNECTOR, BOARD TO BOARD		S757	1-554-303-21	SWITCH, TACTILE (\blacksquare)	
		< DIODE >		S758	1-554-303-21	SWITCH, TACTILE (\odot)	
D751	8-719-987-63	DIODE 1N4148M		S759	1-554-303-21	SWITCH, TACTILE (RESET)	
D752	8-719-987-63	DIODE 1N4148M		S760	1-554-303-21	SWITCH, TACTILE (MEMORY)	
		< FILTER >		S761	1-554-303-21	SWITCH, TACTILE (DISPLAY MODE)	
FLT751	1-519-710-11	INDICATOR TUBE, FLUORESCENT		S762	1-554-303-21	SWITCH, TACTILE (MONITOR)	
		< IC >		S763	1-554-303-21	SWITCH, TACTILE (CAL)	
IC751	8-741-100-48	IC SBX1610-59		*****			
		< RESISTOR >		*	1-632-740-11	MD BOARD *****	
R751	1-249-441-11	CARBON 100K 5% 1/4W			3-356-631-01	HOLDER (SENSOR)	
R756	1-249-441-11	CARBON 100K 5% 1/4W			< CONNECTOR >		
R757	1-249-441-11	CARBON 100K 5% 1/4W		CN1001	1-506-615-11	PIN, CONNECTOR 9P	
R758	1-249-441-11	CARBON 100K 5% 1/4W		CN1002	1-564-501-11	PIN, CONNECTOR 8P	
R759	1-247-838-00	CARBON 2K 5% 1/4W			< IC >		
R760	1-249-422-11	CARBON 2.7K 5% 1/4W		IC1001	8-749-920-97	DI ODE GP2S22B	
R761	1-249-426-11	CARBON 5.6K 5% 1/4W		IC1002	8-749-920-97	DI ODE GP2S22B	
R762	1-247-856-00	CARBON 11K 5% 1/4W			< RESISTOR >		
R763	1-247-838-00	CARBON 2K 5% 1/4W		R1001	1-249-408-11	CARBON 180 5% 1/4W	
R764	1-247-866-11	CARBON 30K 5% 1/4W		R1002	1-249-408-11	CARBON 180 5% 1/4W	
R766	1-247-838-00	CARBON 2K 5% 1/4W			< SWITCH >		
R767	1-249-422-11	CARBON 2.7K 5% 1/4W		S1002	1-570-953-11	SWITCH, PUSH (1 KEY)	
R768	1-249-426-11	CARBON 5.6K 5% 1/4W		S1003	1-571-958-11	SWITCH, PUSH (1 KEY)	
R769	1-247-856-00	CARBON 11K 5% 1/4W		S1004	1-572-126-11	SWITCH, PUSH (1 KEY)	
				S1005	1-572-125-11	SWITCH, LEAF	
				S1006	1-572-202-11	SWITCH, LEAF	

MD **MAIN**

Ref. No.	Part No.	Description	Remarks	Ref. No.	Part No.	Description	Remarks
S1007	1-572-125-11	SWITCH, LEAF		C202	1-162-286-31	CERAMIC 220PF 10% 50V	
S1008	1-572-125-11	SWITCH, LEAF		C203	1-130-475-00	MYLAR 0.0022uF 5% 50V	
< TERMINAL >				C204	1-130-475-00	MYLAR 0.0022uF 5% 50V	
* TB1001	1-694-018-11	TERMINAL (5P)		C205	1-136-174-00	FILM 0.56uF 5% 50V	
*****				C206	1-136-171-00	FILM 0.33uF 5% 50V	
* A-2006-757-A	MAIN BOARD, COMPLETE			C207	1-126-059-11	ELECT 10uF 20% 50V	
*****				C208	1-124-657-00	ELECT 10uF 20% 50V	
* 1-562-327-00	SOCKET, CONNECTOR 3P			C210	1-161-494-00	CERAMIC 0.022uF 25V	
* 1-690-880-31	READ (WITH CONNECTOR)			C221	1-110-340-11	MYLAR 270PF 5% 50V	
* 3-356-925-01	HEAT SINK			C222	1-162-282-31	CERAMIC 100PF 10% 50V	
7-682-547-04	SCREW +BVTT 3X6 (S)			C223	1-130-487-00	MYLAR 0.022uF 5% 50V	
< CAPACITOR >				C224	1-124-657-00	ELECT 10uF 20% 50V	
C101	1-126-059-11	ELECT 10uF 20% 50V		C225	1-130-488-00	MYLAR 0.027uF 5% 50V	
C102	1-162-286-31	CERAMIC 220PF 10% 50V		C226	1-130-474-00	MYLAR 0.0018uF 5% 50V	
C103	1-130-475-00	MYLAR 0.0022uF 5% 50V		C227	1-102-518-11	CERAMIC 33PF 5% 50V	
C104	1-130-475-00	MYLAR 0.0022uF 5% 50V		C228	1-130-474-00	MYLAR 0.0018uF 5% 50V	
C105	1-136-174-00	FILM 0.56uF 5% 50V		C231	1-130-475-00	MYLAR 0.0022uF 5% 50V	
C106	1-136-171-00	FILM 0.33uF 5% 50V		C232	1-130-475-00	MYLAR 0.0022uF 5% 50V	
C107	1-126-059-11	ELECT 10uF 20% 50V		C233	1-136-174-00	FILM 0.56uF 5% 50V	
C108	1-124-657-00	ELECT 10uF 20% 50V		C234	1-136-171-00	FILM 0.33uF 5% 50V	
C110	1-161-494-00	CERAMIC 0.022uF 25V		C235	1-124-657-00	ELECT 10uF 20% 50V	
C121	1-110-340-11	MYLAR 270PF 5% 50V		C241	1-136-175-00	FILM 0.68uF 5% 50V	
C122	1-162-282-31	CERAMIC 100PF 10% 50V		C242	1-126-059-11	ELECT 10uF 20% 50V	
C123	1-130-487-00	MYLAR 0.022uF 5% 50V		C243	1-126-059-11	ELECT 10uF 20% 50V	
C124	1-124-657-00	ELECT 10uF 20% 50V		C244	1-110-338-51	MYLAR 180PF 5% 50V	
C125	1-130-488-00	MYLAR 0.027uF 5% 50V		C245	1-136-935-11	FILM 22PF 5% 630V	
C126	1-130-474-00	MYLAR 0.0018uF 5% 50V		C261	1-124-925-11	ELECT 2.2uF 20% 100V	
C127	1-102-518-11	CERAMIC 33PF 5% 50V		C281	1-136-153-00	FILM 0.01uF 5% 50V	
C128	1-130-474-00	MYLAR 0.0018uF 5% 50V		C282	1-136-157-00	FILM 0.022uF 5% 50V	
C131	1-130-475-00	MYLAR 0.0022uF 5% 50V		C283	1-136-161-00	FILM 0.047uF 5% 50V	
C132	1-130-475-00	MYLAR 0.0022uF 5% 50V		C284	1-136-803-11	FILM 560PF 5% 630V	
C133	1-136-174-00	FILM 0.56uF 5% 50V		C285	1-136-433-11	FILM 100PF 5% 630V	
C134	1-136-171-00	FILM 0.33uF 5% 50V		C286	1-130-468-00	MYLAR 560PF 5% 50V	
C135	1-124-657-00	ELECT 10uF 20% 50V		C501	1-126-022-11	ELECT 47uF 20% 25V	
C141	1-136-175-00	FILM 0.68uF 5% 50V		C502	1-126-022-11	ELECT 47uF 20% 25V	
C142	1-126-059-11	ELECT 10uF 20% 50V		C503	1-130-478-00	MYLAR 0.0039uF 5% 50V	
C143	1-126-059-11	ELECT 10uF 20% 50V		C504	1-136-164-00	FILM 0.082uF 5% 50V	
C144	1-110-338-51	MYLAR 180PF 5% 50V		C505	1-124-902-00	ELECT 0.47uF 20% 50V	
C145	1-136-935-11	FILM 22PF 5% 630V		C506	1-161-494-00	CERAMIC 0.022uF 25V	
C161	1-124-925-11	ELECT 2.2uF 20% 100V		C507	1-124-925-11	ELECT 2.2uF 20% 100V	
C181	1-136-153-00	FILM 0.01uF 5% 50V		C508	1-124-925-11	ELECT 2.2uF 20% 100V	
C182	1-136-157-00	FILM 0.022uF 5% 50V		C509	1-124-925-11	ELECT 2.2uF 20% 100V	
C183	1-136-161-00	FILM 0.047uF 5% 50V		C510	1-124-907-11	ELECT 10uF 20% 50V	
C184	1-136-803-11	FILM 560PF 5% 630V		C521	1-124-994-11	ELECT 100uF 20% 10V	
C185	1-136-433-11	FILM 100PF 5% 630V		C522	1-124-994-11	ELECT 100uF 20% 10V	
C186	1-130-468-00	MYLAR 560PF 5% 50V		C531	1-126-022-11	ELECT 47uF 20% 25V	
C201	1-126-059-11	ELECT 10uF 20% 50V		C532	1-126-022-11	ELECT 47uF 20% 25V	
				C533	1-164-159-11	CERAMIC 0.1uF 50V	
				C534	1-124-903-11	ELECT 1uF 20% 50V	
				C535	1-124-907-11	ELECT 10uF 20% 50V	

Ref. No.	Part No.	Description	Remarks
C536	1-124-907-11	ELECT 10uF 20%	50V
C563	1-162-217-31	CERAMIC 56PF 5%	50V
C564	1-136-157-00	FILM 0.022uF 5%	50V
C565	1-162-217-31	CERAMIC 56PF 5%	50V
C566	1-124-925-11	ELECT 2.2uF 20%	100V
C583	1-124-907-11	ELECT 10uF 20%	50V
C584	1-124-477-11	ELECT 47uF 20%	25V
C585	1-124-477-11	ELECT 47uF 20%	25V
C586	1-136-253-11	FILM 0.0018uF 5%	100V
C587	1-136-253-11	FILM 0.0018uF 5%	100V
C588	1-136-233-11	FILM 0.0047uF 5%	100V
C589	1-161-494-00	CERAMIC 0.022uF	25V
C590	1-126-233-11	ELECT 22uF 20%	50V
C591	1-107-045-00	MICA 3.9PF	500V
C592	1-136-558-11	FILM 0.0039uF 5%	630V
C701	1-162-294-31	CERAMIC 0.001uF 10%	50V
C702	1-162-294-31	CERAMIC 0.001uF 10%	50V
C703	1-124-902-00	ELECT 0.47uF 20%	50V
C704	1-164-159-11	CERAMIC 0.1uF	50V
C705	1-164-159-11	CERAMIC 0.1uF	50V
C707	1-126-923-11	ELECT 220uF 20%	10V
C708	1-124-477-11	ELECT 47uF 20%	25V
C709	1-124-907-11	ELECT 10uF 20%	50V
C710	1-164-159-11	CERAMIC 0.1uF	50V
C711	1-164-159-11	CERAMIC 0.1uF	50V
C712	1-164-159-11	CERAMIC 0.1uF	50V
C803	1-124-556-11	ELECT 2200uF 20%	16V
C804	1-124-556-11	ELECT 2200uF 20%	16V
C806	1-124-477-11	ELECT 47uF 20%	25V
C808	1-124-999-11	ELECT 2200uF 20%	10V
C809	1-124-999-11	ELECT 2200uF 20%	10V
C810	1-124-907-11	ELECT 10uF 20%	50V
C811	1-126-936-11	ELECT 3300uF 20%	16V
C813	1-124-907-11	ELECT 10uF 20%	50V
C814	1-126-916-11	ELECT 1000uF 20%	6.3V
C815	1-124-564-11	ELECT 4700uF 20%	25V
C816	1-124-907-11	ELECT 10uF 20%	50V
C817	1-126-768-11	ELECT 2200uF 20%	16V
C818	1-124-122-11	ELECT 100uF 20%	50V
C819	1-126-947-11	ELECT 47uF 20%	35V
C820	1-164-159-11	CERAMIC 0.1uF	50V

< CONNECTOR >

* CND518 1-564-339-00 PIN, CONNECTOR 5P
 * CND519 1-564-337-61 PIN, CONNECTOR 3P
 * CND703 1-564-338-71 PIN, CONNECTOR 4P
 * CND802 1-564-340-00 PIN, CONNECTOR 6P
 * CNE512 1-564-508-11 PLUG, CONNECTOR 5P

Ref. No.	Part No.	Description	Remarks
* CNE521	1-564-506-11	PLUG, CONNECTOR 3P	
* CNE701	1-564-506-11	PLUG, CONNECTOR 3P	
* CNE702	1-564-505-11	PLUG, CONNECTOR 2P	
* CNE801	1-564-513-11	PLUG, CONNECTOR 10P	
* CNN515	1-560-062-00	PIN, CONNECTOR 4P	
* CNN516	1-560-062-00	PIN, CONNECTOR 4P	
* CNN517	1-560-060-00	PIN, CONNECTOR 2P	
* CNP501	1-564-705-11	PIN, CONNECTOR (SMALL TYPE) 3P	
* CNP508	1-564-705-11	PIN, CONNECTOR (SMALL TYPE) 3P	
* CNP509	1-564-719-11	PIN, CONNECTOR (SMALL TYPE) 3P	
* CNP510	1-564-705-11	PIN, CONNECTOR (SMALL TYPE) 3P	
* CNP513	1-564-707-11	PIN, CONNECTOR (SMALL TYPE) 5P	
* CNP514	1-564-707-11	PIN, CONNECTOR (SMALL TYPE) 5P	
* CNT704	1-580-784-11	CONNECTOR, BOARD TO BOARD	
* CNT705	1-580-784-11	CONNECTOR, BOARD TO BOARD	
* CNT706	1-580-784-11	CONNECTOR, BOARD TO BOARD	
* CNT707	1-580-784-11	CONNECTOR, BOARD TO BOARD	

< DIODE >

D101	8-719-987-63	DIODE 1N4148M
D102	8-719-987-63	DIODE 1N4148M
D201	8-719-987-63	DIODE 1N4148M
D202	8-719-987-63	DIODE 1N4148M
D501	8-719-987-63	DIODE 1N4148M
D502	8-719-987-63	DIODE 1N4148M
D503	8-719-987-63	DIODE 1N4148M
D504	8-719-987-63	DIODE 1N4148M
D505	8-719-987-63	DIODE 1N4148M
D506	8-719-987-63	DIODE 1N4148M
D507	8-719-987-63	DIODE 1N4148M
D508	8-719-987-63	DIODE 1N4148M
D509	8-719-987-63	DIODE 1N4148M
D510	8-719-987-63	DIODE 1N4148M
D511	8-719-987-63	DIODE 1N4148M
D512	8-719-987-63	DIODE 1N4148M
D513	8-719-987-63	DIODE 1N4148M
D514	8-719-987-63	DIODE 1N4148M
D515	8-719-987-63	DIODE 1N4148M
D516	8-719-987-63	DIODE 1N4148M
D701	8-719-987-63	DIODE 1N4148M
D702	8-719-987-63	DIODE 1N4148M
D703	8-719-987-63	DIODE 1N4148M
D704	8-719-987-63	DIODE 1N4148M
D705	8-719-987-63	DIODE 1N4148M
D706	8-719-987-63	DIODE 1N4148M
D707	8-719-200-77	DIODE 10E2N
D708	8-719-933-33	DIODE HZS6A1L
D709	8-719-933-33	DIODE HZS6A1L
D712	8-719-987-63	DIODE 1N4148M

MAIN

Ref. No.	Part No.	Description	Remarks	Ref. No.	Part No.	Description	Remarks
D713	8-719-987-63	DIODE 1N4148M				< FILTER >	
D714	8-719-987-63	DIODE 1N4148M		LPF101	1-236-147-11	FILTER, LOW PASS	
D715	8-719-987-63	DIODE 1N4148M		LPF201	1-236-147-11	FILTER, LOW PASS	
D718	8-719-987-63	DIODE 1N4148M				< TRANSISTOR >	
D801	8-719-200-77	DIODE 10E2N					
D802	8-719-200-77	DIODE 10E2N		Q101	8-729-142-25	TRANSISTOR 2SD1020-HFE	
D803	8-719-200-77	DIODE 10E2N		Q102	8-729-142-25	TRANSISTOR 2SD1020-HFE	
D804	8-719-200-77	DIODE 10E2N		Q103	8-729-900-74	TRANSISTOR DTC143TS	
D805	8-719-933-33	DIODE HZS6A1L		Q201	8-729-142-25	TRANSISTOR 2SD1020-HFE	
D806	8-719-933-33	DIODE HZS6A1L		Q202	8-729-142-25	TRANSISTOR 2SD1020-HFE	
D807	8-719-987-63	DIODE 1N4148M		Q203	8-729-900-74	TRANSISTOR DTC143TS	
D812	8-719-987-63	DIODE 1N4148M		Q501	8-729-620-05	TRANSISTOR 2SC2603-EF	
D813	8-719-200-31	DIODE 21DQ05		Q502	8-729-620-05	TRANSISTOR 2SC2603-EF	
D814	8-719-000-78	DIODE UZL-7L2		Q503	8-729-922-37	TRANSISTOR 2SD2144S	
D815	8-719-987-63	DIODE 1N4148M		Q504	8-729-900-80	TRANSISTOR DTC114ES	
D816	8-719-987-63	DIODE 1N4148M		Q505	8-729-119-76	TRANSISTOR 2SA1175-HFE	
D817	8-719-001-70	DIODE UZL-12M1		Q506	8-729-142-25	TRANSISTOR 2SD1020-HFE	
D818	8-719-200-77	DIODE 10E2N		Q507	8-729-900-80	TRANSISTOR DTC114ES	
D819	8-719-200-77	DIODE 10E2N		Q508	8-729-821-04	TRANSISTOR 2SA1317-STU	
D820	8-719-000-93	DIODE UZL-7H1		Q509	8-729-900-80	TRANSISTOR DTC114ES	
D822	8-719-987-63	DIODE 1N4148M		Q510	8-729-900-80	TRANSISTOR DTC114ES	
D823	8-719-312-09	DIODE RBA-402		Q511	8-729-194-57	TRANSISTOR 2SC945-P	
		< IC >		Q512	8-729-194-57	TRANSISTOR 2SC945-P	
IC501	8-752-059-55	IC CXA1331S		Q513	8-729-900-80	TRANSISTOR DTC114ES	
IC502	8-759-000-49	IC MC14066BCP		Q514	8-729-900-80	TRANSISTOR DTC114ES	
IC503	8-752-060-64	IC CXA1198AP		Q515	8-729-900-80	TRANSISTOR DTC114ES	
IC504	8-759-106-56	IC uPC1297CA		Q516	8-729-900-80	TRANSISTOR DTC114ES	
IC505	8-759-111-44	IC uPC4570C-1		Q517	8-729-900-80	TRANSISTOR DTC114ES	
IC506	8-752-059-55	IC CXA1331S		Q701	8-729-900-61	TRANSISTOR DTA114ES	
IC507	8-759-634-51	IC M5218AP		Q702	8-729-900-61	TRANSISTOR DTA114ES	
IC508	8-759-945-58	IC RC4558P		Q703	8-729-900-61	TRANSISTOR DTA114ES	
IC509	8-759-945-58	IC RC4558P		Q704	8-729-900-61	TRANSISTOR DTA114ES	
IC510	8-759-634-50	IC M5218AL		Q705	8-729-119-76	TRANSISTOR 2SA1175-HFE	
IC701	8-759-060-83	IC M50941-728SP		Q706	8-729-119-76	TRANSISTOR 2SA1175-HFE	
IC702	8-759-240-69	IC TC4069UBP		Q707	8-729-900-61	TRANSISTOR DTA114ES	
IC703	8-759-973-95	IC BA6219B		Q708	8-729-900-61	TRANSISTOR DTA114ES	
IC704	8-759-822-09	IC LB1641		Q709	8-729-620-05	TRANSISTOR 2SC2603-EF	
IC801	8-759-945-58	IC RC4558P		Q710	8-729-900-80	TRANSISTOR DTC114ES	
		< JACK >		Q711	8-729-900-65	TRANSISTOR DTA144ES	
J501	1-565-258-11	JACK, PIN 4P (LINE OUT)		Q712	8-729-900-80	TRANSISTOR DTC114ES	
J502	1-507-796-71	JACK (HEADPHONES)		Q713	8-729-900-65	TRANSISTOR DTA144ES	
		< COIL >		Q714	8-729-620-05	TRANSISTOR 2SC2603-EF	
L121	1-410-778-11	INDUCTOR 18mH		Q715	8-729-900-89	TRANSISTOR DTC144ES	
L141	1-410-780-11	INDUCTOR 27mH		Q716	8-729-900-89	TRANSISTOR DTC144ES	
L221	1-410-778-11	INDUCTOR 18mH		Q717	8-729-900-61	TRANSISTOR DTA114ES	
L241	1-410-780-11	INDUCTOR 27mH		Q718	8-729-900-61	TRANSISTOR DTA114ES	
L501	1-408-080-00	INDUCTOR 100uH		Q719	8-729-900-61	TRANSISTOR DTA114ES	
				Q720	8-729-900-61	TRANSISTOR DTA114ES	
				Q721	8-729-900-61	TRANSISTOR DTA114ES	
				Q722	8-729-900-61	TRANSISTOR DTA114ES	

Ref. No.	Part No.	Description	Remarks
Q723	8-729-900-65	TRANSISTOR DTA144ES	
Q724	8-729-900-65	TRANSISTOR DTA144ES	
Q725	8-729-900-80	TRANSISTOR DTC114ES	
Q726	8-729-900-65	TRANSISTOR DTA144ES	
Q727	8-729-900-65	TRANSISTOR DTA144ES	
Q729	8-729-900-61	TRANSISTOR DTA114ES	
Q801	8-729-900-61	TRANSISTOR DTA114ES	
Q802	8-729-900-80	TRANSISTOR DTC114ES	
Q803	8-729-141-83	TRANSISTOR 2SB1094-LK	
Q804	8-729-209-15	TRANSISTOR 2SD2012	
Q805	8-729-209-15	TRANSISTOR 2SD2012	
Q806	8-729-620-05	TRANSISTOR 2SC2603-EF	
Q807	8-729-900-80	TRANSISTOR DTC114ES	
Q808	8-729-141-83	TRANSISTOR 2SB1094-LK	
Q809	8-729-620-05	TRANSISTOR 2SC2603-EF	
Q810	8-729-119-76	TRANSISTOR 2SA1175-HFE	
Q811	8-729-140-04	TRANSISTOR 2SB1116A-L	
< RESISTOR >			
R101	1-259-460-11	CARBON 22K 5% 1/6W	
R104	1-259-440-11	CARBON 3.3K 5% 1/6W	
R105	1-259-450-11	CARBON 8.2K 5% 1/6W	
R106	1-259-461-11	CARBON 24K 5% 1/6W	
R107	1-259-422-11	CARBON 560 5% 1/6W	
R108	1-259-476-11	CARBON 100K 5% 1/6W	
R109	1-259-436-11	CARBON 2.2K 5% 1/6W	
R110	1-249-421-11	CARBON 2.2K 5% 1/4W	
R111	1-259-467-11	CARBON 43K 5% 1/6W	
R112	1-259-428-11	CARBON 1K 5% 1/6W	
R115	1-249-421-11	CARBON 2.2K 5% 1/4W	
R121	1-259-476-11	CARBON 100K 5% 1/6W	
R122	1-259-402-11	CARBON 82 5% 1/6W	
R123	1-259-479-11	CARBON 130K 5% 1/6W	
R124	1-259-446-11	CARBON 5.6K 5% 1/6W	
R125	1-259-434-11	CARBON 1.8K 5% 1/6W	
R126	1-259-435-11	CARBON 2K 5% 1/6W	
R127	1-259-484-11	CARBON 220K 5% 1/6W	
R131	1-249-429-11	CARBON 10K 5% 1/4W	
R132	1-249-429-11	CARBON 10K 5% 1/4W	
R133	1-249-429-11	CARBON 10K 5% 1/4W	
R134	1-259-461-11	CARBON 24K 5% 1/6W	
R135	1-259-422-11	CARBON 560 5% 1/6W	
R136	1-259-452-11	CARBON 10K 5% 1/6W	
R137	1-259-476-11	CARBON 100K 5% 1/6W	
R141	1-259-444-11	CARBON 4.7K 5% 1/6W	
R142	1-259-442-11	CARBON 3.9K 5% 1/6W	
R143	1-259-440-11	CARBON 3.3K 5% 1/6W	
R144	1-259-452-11	CARBON 10K 5% 1/6W	
R145	1-249-421-11	CARBON 2.2K 5% 1/4W	

Ref. No.	Part No.	Description	Remarks
R146	1-259-444-11	CARBON 4.7K 5% 1/6W	
R151	1-249-433-11	CARBON 22K 5% 1/4W	
R152	1-249-421-11	CARBON 2.2K 5% 1/4W	
R153	1-247-862-11	CARBON 20K 5% 1/4W	
R154	1-249-409-11	CARBON 220 5% 1/4W	
R161	1-249-434-11	CARBON 27K 5% 1/4W	
R162	1-247-874-11	CARBON 62K 5% 1/4W	
R163	1-249-410-11	CARBON 270 5% 1/4W	
R181	1-249-427-11	CARBON 6.8K 5% 1/4W	
R182	1-249-435-11	CARBON 33K 5% 1/4W	
ΔR183	1-219-153-11	FUSEBLE 10 5% 1/4W	F
R184	1-247-883-00	CARBON 150K 5% 1/4W	
R201	1-259-460-11	CARBON 22K 5% 1/6W	
R204	1-259-440-11	CARBON 3.3K 5% 1/6W	
R205	1-259-450-11	CARBON 8.2K 5% 1/6W	
R206	1-259-461-11	CARBON 24K 5% 1/6W	
R207	1-259-422-11	CARBON 560 5% 1/6W	
R208	1-259-476-11	CARBON 100K 5% 1/6W	
R209	1-259-436-11	CARBON 2.2K 5% 1/6W	
R210	1-249-421-11	CARBON 2.2K 5% 1/4W	
R211	1-259-467-11	CARBON 43K 5% 1/6W	
R212	1-259-428-11	CARBON 1K 5% 1/6W	
R215	1-249-421-11	CARBON 2.2K 5% 1/4W	
R221	1-259-476-11	CARBON 100K 5% 1/6W	
R222	1-259-402-11	CARBON 82 5% 1/6W	
R223	1-259-479-11	CARBON 130K 5% 1/6W	
R224	1-259-446-11	CARBON 5.6K 5% 1/6W	
R225	1-259-434-11	CARBON 1.8K 5% 1/6W	
R226	1-259-435-11	CARBON 2K 5% 1/6W	
R227	1-259-484-11	CARBON 220K 5% 1/6W	
R231	1-249-429-11	CARBON 10K 5% 1/4W	
R232	1-249-429-11	CARBON 10K 5% 1/4W	
R233	1-249-429-11	CARBON 10K 5% 1/4W	
R234	1-259-461-11	CARBON 24K 5% 1/6W	
R235	1-259-422-11	CARBON 560 5% 1/6W	
R236	1-259-452-11	CARBON 10K 5% 1/6W	
R237	1-259-476-11	CARBON 100K 5% 1/6W	
R241	1-259-444-11	CARBON 4.7K 5% 1/6W	
R242	1-259-442-11	CARBON 3.9K 5% 1/6W	
R243	1-259-440-11	CARBON 3.3K 5% 1/6W	
R244	1-259-452-11	CARBON 10K 5% 1/6W	
R245	1-249-421-11	CARBON 2.2K 5% 1/4W	
R246	1-259-444-11	CARBON 4.7K 5% 1/6W	
R251	1-249-433-11	CARBON 22K 5% 1/4W	
R252	1-249-421-11	CARBON 2.2K 5% 1/4W	
R253	1-247-862-11	CARBON 20K 5% 1/4W	
R254	1-249-409-11	CARBON 220 5% 1/4W	
R261	1-249-434-11	CARBON 27K 5% 1/4W	
R262	1-247-874-11	CARBON 62K 5% 1/4W	
R263	1-249-410-11	CARBON 270 5% 1/4W	

Note:
The components identified by mark Δ or dotted line with mark Δ are critical for safety. Replace only with part number specified.

Note:
Les composants identifiés par une marque Δ sont critiques pour la sécurité. Ne les remplacer que par une pièce portant le numéro spécifié.

MAIN

Ref. No.	Part No.	Description	Remarks	Ref. No.	Part No.	Description	Remarks
R281	1-249-427-11	CARBON	6.8K 5% 1/4W	R586	1-249-417-11	CARBON	1K 5% 1/4W
R282	1-249-435-11	CARBON	33K 5% 1/4W	R587	1-249-440-11	CARBON	82K 5% 1/4W
△R283	1-219-153-11	FUSEBLE	10 5% 1/4W F	R588	1-249-440-11	CARBON	82K 5% 1/4W
R284	1-247-883-00	CARBON	150K 5% 1/4W	R589	1-249-390-11	CARBON	5.6 5% 1/6W
R501	1-259-428-11	CARBON	1K 5% 1/6W	R590	1-249-390-11	CARBON	5.6 5% 1/6W
R502	1-215-455-00	METAL	27K 1% 1/6W	R591	1-249-421-11	CARBON	2.2K 5% 1/4W
R504	1-249-418-11	CARBON	1.2K 5% 1/4W	R592	1-249-429-11	CARBON	10K 5% 1/4W
R505	1-249-427-11	CARBON	6.8K 5% 1/4W	R601	1-249-439-11	CARBON	68K 5% 1/4W
R507	1-247-848-11	CARBON	5.1K 5% 1/4W	R602	1-249-435-11	CARBON	33K 5% 1/4W
R508	1-249-433-11	CARBON	22K 5% 1/4W	R603	1-249-437-11	CARBON	47K 5% 1/4W
R509	1-249-436-11	CARBON	39K 5% 1/4W	R604	1-247-874-11	CARBON	62K 5% 1/4W
R510	1-249-421-11	CARBON	2.2K 5% 1/4W	R605	1-249-441-11	CARBON	100K 5% 1/4W
R511	1-249-421-11	CARBON	2.2K 5% 1/4W	R606	1-249-433-11	CARBON	22K 5% 1/4W
R512	1-249-441-11	CARBON	100K 5% 1/4W	R607	1-247-874-11	CARBON	62K 5% 1/4W
R513	1-249-441-11	CARBON	100K 5% 1/4W	R608	1-249-437-11	CARBON	47K 5% 1/4W
R514	1-247-836-11	CARBON	1.6K 5% 1/4W	R609	1-247-880-11	CARBON	110K 5% 1/4W
R516	1-249-437-11	CARBON	47K 5% 1/4W	R610	1-247-878-00	CARBON	91K 5% 1/4W
R517	1-249-433-11	CARBON	22K 5% 1/4W	R611	1-249-439-11	CARBON	68K 5% 1/4W
R518	1-249-427-11	CARBON	6.8K 5% 1/4W	R612	1-247-887-00	CARBON	220K 5% 1/4W
R519	1-249-437-11	CARBON	47K 5% 1/4W	R613	1-249-439-11	CARBON	68K 5% 1/4W
R520	1-249-434-11	CARBON	27K 5% 1/4W	R614	1-247-872-11	CARBON	51K 5% 1/4W
R521	1-247-704-11	CARBON	220 5% 1/4W	R616	1-247-874-11	CARBON	62K 5% 1/4W
R522	1-247-704-11	CARBON	220 5% 1/4W	R617	1-247-874-11	CARBON	62K 5% 1/4W
R523	1-249-429-11	CARBON	10K 5% 1/4W	R618	1-247-886-11	CARBON	200K 5% 1/4W
R524	1-249-429-11	CARBON	10K 5% 1/4W	R619	1-249-435-11	CARBON	33K 5% 1/4W
R525	1-249-429-11	CARBON	10K 5% 1/4W	R701	1-247-887-00	CARBON	220K 5% 1/4W
R526	1-249-422-11	CARBON	2.7K 5% 1/4W	R702	1-247-887-00	CARBON	220K 5% 1/4W
R527	1-249-437-11	CARBON	47K 5% 1/4W	R703	1-249-436-11	CARBON	39K 5% 1/4W
R528	1-249-441-11	CARBON	100K 5% 1/4W	R704	1-247-887-00	CARBON	220K 5% 1/4W
R529	1-249-431-11	CARBON	15K 5% 1/4W	R705	1-249-436-11	CARBON	39K 5% 1/4W
R531	1-259-428-11	CARBON	1K 5% 1/6W	R706	1-247-887-00	CARBON	220K 5% 1/4W
R532	1-215-455-00	METAL	27K 1% 1/6W	R707	1-249-431-11	CARBON	15K 5% 1/4W
R533	1-249-437-11	CARBON	47K 5% 1/4W	R708	1-247-868-11	CARBON	36K 5% 1/4W
R534	1-249-441-11	CARBON	100K 5% 1/4W	R709	1-249-435-11	CARBON	33K 5% 1/4W
R535	1-215-454-00	METAL	24K 1% 1/6W	R710	1-249-435-11	CARBON	33K 5% 1/4W
R563	1-249-441-11	CARBON	100K 5% 1/4W	R711	1-247-872-11	CARBON	51K 5% 1/4W
R564	1-249-429-11	CARBON	10K 5% 1/4W	R712	1-249-435-11	CARBON	33K 5% 1/4W
R565	1-249-441-11	CARBON	100K 5% 1/4W	R713	1-249-435-11	CARBON	33K 5% 1/4W
R566	1-249-428-11	CARBON	8.2K 5% 1/4W	R714	1-249-435-11	CARBON	33K 5% 1/4W
R567	1-249-441-11	CARBON	100K 5% 1/4W	R715	1-249-435-11	CARBON	33K 5% 1/4W
R568	1-249-423-11	CARBON	3.3K 5% 1/4W	R716	1-249-435-11	CARBON	33K 5% 1/4W
R569	1-249-441-11	CARBON	100K 5% 1/4W	R717	1-249-435-11	CARBON	33K 5% 1/4W
R570	1-249-429-11	CARBON	10K 5% 1/4W	R719	1-249-429-11	CARBON	10K 5% 1/4W
R571	1-249-429-11	CARBON	10K 5% 1/4W	△R720	1-212-954-11	FUSEBLE	6.8 5% 1/2W F
R572	1-249-417-11	CARBON	1K 5% 1/4W	R721	1-249-429-11	CARBON	10K 5% 1/4W
R581	1-249-429-11	CARBON	10K 5% 1/4W	R722	1-249-431-11	CARBON	15K 5% 1/4W
R582	1-249-429-11	CARBON	10K 5% 1/4W	R723	1-247-834-11	CARBON	1.3K 5% 1/4W
R583	1-247-822-11	CARBON	430 5% 1/4W	R724	1-249-424-11	CARBON	3.9K 5% 1/4W
R584	1-249-417-11	CARBON	1K 5% 1/4W	R725	1-247-834-11	CARBON	1.3K 5% 1/4W
R585	1-247-862-11	CARBON	20K 5% 1/4W	R726	1-249-427-11	CARBON	6.8K 5% 1/4W

Note:
The components identified by mark △ or dotted line with mark △ are critical for safety. Replace only with part number specified.

Note:
Les composants identifiés par une marque △ sont critiques pour la sécurité. Ne les remplacer que par une pièce portant le numéro spécifié.

Ref. No.	Part No.	Description	Remarks
R727	1-249-430-11	CARBON 12K 5% 1/4W	
△R728	1-212-952-00	FUSEBLE 5.6 5% 1/2W F	
R729	1-249-435-11	CARBON 33K 5% 1/4W	
R730	1-249-435-11	CARBON 33K 5% 1/4W	
R731	1-249-425-11	CARBON 4.7K 5% 1/4W	
R732	1-249-417-11	CARBON 1K 5% 1/4W	
R733	1-247-903-00	CARBON 1M 5% 1/4W	
R735	1-249-421-11	CARBON 2.2K 5% 1/4W	
△R736	1-212-942-00	FUSEBLE 2.2 5% 1/2W F	
R737	1-249-429-11	CARBON 10K 5% 1/4W	
R738	1-249-429-11	CARBON 10K 5% 1/4W	
R739	1-249-429-11	CARBON 10K 5% 1/4W	
R740	1-249-425-11	CARBON 4.7K 5% 1/4W	
R742	1-249-441-11	CARBON 100K 5% 1/4W	
R743	1-249-441-11	CARBON 100K 5% 1/4W	
R744	1-249-441-11	CARBON 100K 5% 1/4W	
R745	1-249-432-11	CARBON 18K 5% 1/4W	
R746	1-249-429-11	CARBON 10K 5% 1/4W	
R747	1-249-429-11	CARBON 10K 5% 1/4W	
R748	1-249-429-11	CARBON 10K 5% 1/4W	
R749	1-247-862-11	CARBON 20K 5% 1/4W	
R750	1-247-866-11	CARBON 30K 5% 1/4W	
R752	1-249-441-11	CARBON 100K 5% 1/4W	
R753	1-249-441-11	CARBON 100K 5% 1/4W	
R754	1-249-441-11	CARBON 100K 5% 1/4W	
R755	1-249-441-11	CARBON 100K 5% 1/4W	
R770	1-249-441-11	CARBON 100K 5% 1/4W	
R802	1-249-425-11	CARBON 4.7K 5% 1/4W	
R803	1-249-420-11	CARBON 1.8K 5% 1/4W	
R804	1-249-412-11	CARBON 390 5% 1/4W	
R805	1-249-427-11	CARBON 6.8K 5% 1/4W	
R806	1-249-419-11	CARBON 1.5K 5% 1/4W	
R807	1-259-452-11	CARBON 10K 5% 1/6W	
R808	1-259-432-11	CARBON 1.5K 5% 1/6W	
R809	1-249-425-11	CARBON 4.7K 5% 1/4W	
R810	1-249-409-11	CARBON 220 5% 1/4W	
R811	1-259-428-11	CARBON 1K 5% 1/6W	
R812	1-259-448-11	CARBON 6.8K 5% 1/6W	
R813	1-259-448-11	CARBON 6.8K 5% 1/6W	
R814	1-249-417-11	CARBON 1K 5% 1/4W	
R815	1-249-425-11	CARBON 4.7K 5% 1/4W	
R816	1-249-425-11	CARBON 4.7K 5% 1/4W	
R817	1-249-425-11	CARBON 4.7K 5% 1/4W	
R818	1-249-433-11	CARBON 22K 5% 1/4W	
R819	1-249-436-11	CARBON 39K 5% 1/4W	
R820	1-249-429-11	CARBON 10K 5% 1/4W	
R821	1-249-437-11	CARBON 47K 5% 1/4W	
△R825	1-219-135-11	FUSEBLE 0.15 10% 1/4W	
△R826	1-219-137-11	FUSEBLE 0.33 10% 1/4W	

Ref. No.	Part No.	Description	Remarks
< VARIABLE RESISTOR >			
RV121	1-238-015-11	RES, ADJ, CARBON 4.7K	
RV141	1-238-017-11	RES, ADJ, CARBON 22K	
RV181	1-238-017-11	RES, ADJ, CARBON 22K	
RV221	1-238-015-11	RES, ADJ, CARBON 4.7K	
RV241	1-238-017-11	RES, ADJ, CARBON 22K	
RV281	1-238-017-11	RES, ADJ, CARBON 22K	
RV501	1-241-403-11	RES, VAR, CARBON 50K/50K (REC LEVEL)	
RV502	1-238-904-11	RES, VAR, CARBON 50K/50K (BALANCE)	
RV503	1-241-404-11	RES, VAR, CARBON 5K/5K (CALIBRATION REC LEVEL)	
RV505	1-238-085-11	REA, VAR, CARBON 20K/20K (PHONE LEVEL)	
RV506	1-241-747-11	RES, VAR, CARBON 10K (CALIBRATION BIAS)	
RV508	1-238-022-51	RES, ADJ, CARBON 330K	
< SWITCH >			
S501	1-572-154-11	SWITCH, ROTARY (DOLBY NR)	
S502	1-554-118-00	SWITCH, PUSH (1 KEY) (MPX FILTER)	
S701	1-571-520-11	SWITCH, SLIDE (TIMER)	
S801	1-554-118-00	SWITCH, PUSH (1 KEY) (POWER)	
< TRANSFORMER >			
T181	1-433-344-11	TRANSFORMER, BIAS OSCILLATION	
T281	1-433-344-11	TRANSFORMER, BIAS OSCILLATION	
T501	1-433-343-11	TRANSFORMER, BIAS OSCILLATION	
< VIBRATOR >			
X701	1-577-359-21	VIBRATOR, CERAMIC 4.19MHz	

*	1-632-741-11	REEL MOTOR BOARD	

< CAPACITOR >			
C1051	1-124-907-11	ELECT 10uF 20% 50V	
C1052	1-124-907-11	ELECT 10uF 20% 50V	
C1053	1-164-159-11	CERAMIC 0.1uF 50V	
< CONNECTOR >			
* CN1051	1-564-499-11	PIN, CONNECTOR 6P	
* CN1052	1-564-718-11	PIN, CONNECTOR (SMALL TYPE) 2P	
* CN1053	1-564-718-11	PIN, CONNECTOR (SMALL TYPE) 2P	
< RESISTOR >			
R1051	1-249-414-11	CARBON 560 5% 1/4W	



<p>Note: The components identified by mark △ or dotted line with mark △ are critical for safety. Replace only with part number specified.</p>	<p>Note: Les composants identifiés par une marque △ sont critiques pour la sécurité. Ne les remplacer que par une pièce portant le numéro spécifié.</p>
--	---

Ref. No.	Part No.	Description	Remarks
MISCELLANEOUS *****			
△12	1-555-795-00	CORD, POWER, EULO PLUG (AEP, Germany)	
△12	1-556-035-00	CORD, POWER (UK)	
△12	1-558-945-11	CORD, POWER (POLAR. SPT-1) (Canadian)	
D1051	8-719-980-85	DIODE SLF325C	
HRP10011-543-733-11		HEAD, MAGNETIC(RECORD/PLAYBACK)	
M1051	X-3356-638-1	MOTOR (REEL R) ASSY	
M1052	X-3356-604-1	MOTOR (ASSIST) ASSY	
M1053	X-3356-646-1	MOTOR (CAPSTAN V1) ASSY	
S1001	1-466-238-11	ENCODER, ROTARY	
△T901	1-450-100-11	TRANSFORMER, POWER (Canadian)	
△T901	1-450-399-11	TRANSFORMER, POWER (AEP, UK, Germany)	

ACCESSORIES & PACKING MATERIALS

	1-558-271-11	CORD, CONNECTION
	1-558-271-11	CORD, CONNECTION
*	3-350-830-01	CUSHION
*	3-376-443-51	INDIVIDUAL CARTON
	3-755-084-11	MANUAL, INSTRUCTION (ENGLISH/FRENCH /SPANISH/PORTUGUESE) (Canadian, AEP, UK)
	3-755-084-41	MANUAL, INSTRUCTION (GERMAN/SWEDISH /DUTCH/ITALIAN) (AEP)
	3-755-084-51	MANUAL, INSTRUCTION (GERMAN) (Germany)

Ref. No.	Part No.	Description	Remarks
***** HARDWARE LIST *****			
#1	7-685-534-19	SCREW +BTP 2.6X8 TYPE2 N-S	
#2	7-682-547-04	SCREW +BVTT 3X6 (S)	
#3	7-682-548-09	SCREW +BVTT 3X8 (S)	
#4	7-621-849-00	SCREW (BV/RING)	
#5	7-621-255-35	SCREW +BVTT 2X5 (S)	
#6	7-621-255-20	SCREW +BVTT 2X4 (S)	
#7	7-685-133-19	SCREW +BTP 2.6X6 TYPE2 N-S	
#8	7-685-132-19	SCREW +BTP 2.6X5 TYPE2 N-S	
#9	7-621-772-20	SCREW +B 2X5	

Note:
The components identified by mark  or dotted line with mark  are critical for safety. Replace only with part number specified.

Note:
Les composants identifiés par une marque  sont critiques pour la sécurité. Ne les remplacer que par une pièce portant le numéro spécifié.