

TC-K600ES

SERVICE MANUAL

West Germany Model



Model Name Using Similar Mechanism	TC-W 550
Tape Transport Mechanism Type	TCM-CMAY B-27

SPECIFICATIONS

Aufnahmesystem	4 Spuren, 2-Kanal-Stereo
Vormagnetisierung	Wechselstrom
Köpfe	Löschkopf × 1 (F & F) Aufnahmekopf × 1 (Permalloy) Wiedergabekopf × 1 (Laseramorphous)
Motoren	Capstan-Motor × 1 (Gleichstromservo-Typ) Aufwickel/Abwickel-Motor × 1 (Gleichstrom-Typ)
Gleichlaufschwankungen	±0,14% W Peak (DIN)
Umspulzeit	ca. 90 Sek. (mit C-60-Cassette)

Frequenzgang (Dolby ausgeschaltet)

TYPE IV-Cassette (Sony METAL-ES)	20–21.000 Hz (±3 dB, DIN) 20–16.000 Hz (±3 dB, 0VU Aufnahme)
TYPE II-Cassette (Sony UX-S)	20–19.000 Hz (±3 dB, DIN)
TYPE I-Cassette (Sony HF-S)	20–17.000 Hz (±3 dB, DIN)

Signal-Rauschabstand (bei Spitzenpegel)

Dolby NR-Schalter Cassette	OFF	B-TYPE ON	C-TYPE ON
TYPE IV (Sony METAL-ES)	59 dB	66 dB	72 dB
TYPE II (Sony UX-S)	58 dB	65 dB	71 dB
TYPE I (Sony HF-S)	55 dB	62 dB	68 dB

Gesamtklirrgrad 1,0% (mit Sony METAL-ES-Cassette)
Eingänge

Line-Eingänge (Cinchbuchsen)	Empfindlichkeit	77,5 mV (–20 dB)
	Eingangsimpedanz	50 kOhm

Ausgänge

Line-Ausgänge (Cinchbuchsen)	Nennausgangs- pegel	0,44 V (–5 dB) bei Lastimpedanz von 47 kOhm
	Lastimpedanz	über 10 kOhm
Kopfhörerausgang (Stereo- Klinkenbuchse)	Ausgangspegel	0–2,5 mW bei Lastimpedanz von 32 Ohm

Allgemeine Daten

Stromversorgung 220 V Wechselspannung, 50/60 Hz

Leistungsaufnahme

20 W

Abmessungen

ca. 430 × 118 × 345 mm (B/H/T)
einschl. vorspringender Teile und
Bedienungselemente

Gewicht

ca. 5,2 kg

Mitgeliefertes Zubehör

Audio-Verbindungskabel (2)



Änderungen, die dem technischen Fortschritt dienen,
bleiben vorbehalten.

STEREO CASSETTE DECK
SONY®

TABLE OF CONTENTS

<i>Section</i>	<i>Title</i>	<i>Page</i>	<i>Section</i>	<i>Title</i>	<i>Page</i>
SPECIFICATIONS		1	SECTION 5 EXPLODED VIEWS		18
SECTION 1 GENERAL		2	5-1. CABINET SECTION		18
1-1. LOCATION AND FUNCTION OF CONTROLS ..		2	5-2. FRONT PANEL SECTION		19
SECTION 2 MECHANICAL ADJUSTMENTS		3	SECTION 6 ELECTRICAL PARTS LIST		20
SECTION 3 ELECTRICAL ADJUSTMENTS		3			
SECTION 4 DIAGRAMS					
4-1. SEMICONDUCTOR LEAD LAYOUTS		6			
4-2. PRINTED WIRING BOARDS		7			
4-3. SCHEMATIC DIAGRAM					
—AUDIO/SYSTEM CONTROL SECTION—		11			
4-4. SCHEMATIC DIAGRAM					
—DISPLAY SECTION—		16			







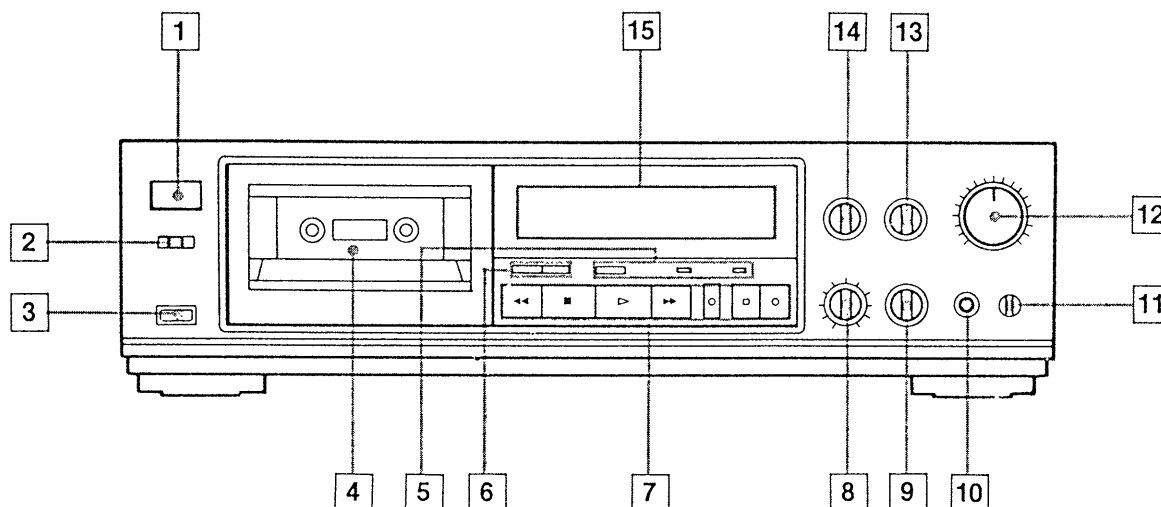

SAFETY-RELATED COMPONENT WARNING!!

COMPONENTS IDENTIFIED BY MARK  OR DOTTED LINE WITH MARK  ON THE SCHEMATIC DIAGRAMS AND IN THE PARTS LIST ARE CRITICAL TO SAFE OPERATION. REPLACE THESE COMPONENTS WITH SONY PARTS WHOSE PART NUMBERS APPEAR AS SHOWN IN THIS MANUAL OR IN SUPPLEMENTS PUBLISHED BY SONY.

SECTION 1 GENERAL

1-1. LOCATION AND FUNCTION OF CONTROLS



- | | |
|------------------------------------------------------------------------------------------------------------------------------------------------------------------------------------------------------------------------------------------------------------------------------------------------------------------------------------------------------------------------------------------------------------------------------------------------------------------------------------------------------------------------------------------------------------------------------------------------------------------------------------------------------------------------------------------------------------------------------------------------------------------------------------------------------------------------------------------------------|---------------------------------------------------------------------------------------------|
| 1 Netzschalter (POWER) | 8 Vormagnetisierungsstrom-Einstellregler (BIAS) |
| 2 Timerschalter (TIMER) | 9 Monitorschalter (MONITOR) |
| 3 Auswurf-taste () | 10 Kopfhörerbuchse (PHONES) |
| 4 Cassettenhalter | 11 Kopfhörerpegelregler (PHONES LEVEL) |
| 5 Betriebsartentaste (TAPE OPERATION)
AMS/Leerstellensprung-Anzeige (AMS/BLANK SKIP)
und Anspielautomatik-Anzeige (MUSIC SCAN) | 12 Aufnahmepegelregler (REC LEVEL) |
| 6 Zählertasten (COUNTER)
Rückstell-taste/Speichertaste (RESET/MEMORY) | 13 Multi-Filter-schalter (MPX FILTER) |
| 7 Bandlauf-Funktionstasten und Anzeigen
Rückspultaste ()
Stopptaste ()
Wiedergabetaste und Anzeige ()
Vorspultaste ()
Aufnahmetaste und Anzeige ()
Pausentaste und Anzeige ()
Aufnahmeausspartaste () | 14 Dolby-Rauschverminderungsschalter (DOLBY NR) |
| | 15 Linearzähler (LINEAR COUNTER) und Programm-Spitzenpegelmeter (PEAK PROGRAM METER) |

SECTION 2 MECHANICAL ADJUSTMENTS

PRECAUTION

1. Clean the following parts with a denatured-alcohol-moistened swab:

record/playback head	pinch roller
erase head	rubber belts
capstan	idlers
2. Demagnetize the record/playback head with a head demagnetizer. (Do not bring the head demagnetizer close to the erase head.)
3. Do not use a magnetized screwdriver for the adjustments.
4. After the adjustments, apply suitable locking compound to the parts adjusted.
5. The adjustments should be performed with the rated power supply voltage unless otherwise noted.

Torque Measurement

Torque	Torque meter	Meter reading
Forward	CQ-102C	30-70g·cm (0.42-0.97oz·inch)
Forward back tension	CQ-102C	2-6g·cm (0.028-0.083oz·inch)
FF/REW	CQ-201B	90-180g·cm (1.25-2.5oz·inch)

SECTION 3 ELECTRICAL ADJUSTMENTS

1. The adjustment should be performed in the publication (Be sure to make playback adjustment at first.)
2. The adjustment and measurement should be performed for both L-CH and R-CH.
 - Switch position
DOLBY NR switch: OFF
TIMER switch: OFF
 - Standard record position
Deliver the standard input signal level to the input jack and set the REC LEVEL control to obtain the standard output signal level as follows.

—Record mode—

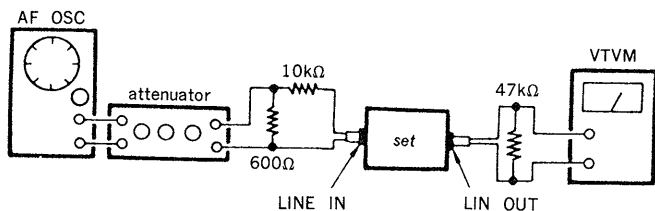

• Standard Input Level

Input terminal	LINE IN
source impedance	10kΩ
input signal level	0.25V (-10dB)

• Standard Output Level

Output terminal	LINE OUT
load impedance	47kΩ
output signal level	0.44V (-5dB)

Test Tape

Tape	Contents	Use
P-4-A100	10kHz, -10dB	Record/Playback Head Azimuth Adjustment
WS-48B	3kHz, 0dB	Tape Speed Adjustment
P-4-L300	315Hz, 0dB	Playback Level Adjustment

Record/Playback Head Azimuth Adjustment procedure:

1. Playback Mode

test tape
P-4-A100
(10kHz, -10dB)

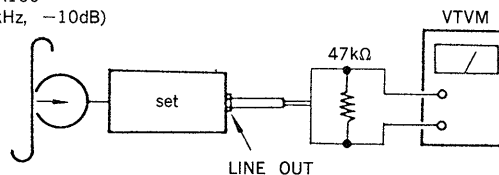

2. Turn the adjustment screw for the maximum output levels. If these levels do not match, turn the adjustment screw until both of output levels match together within 1dB.

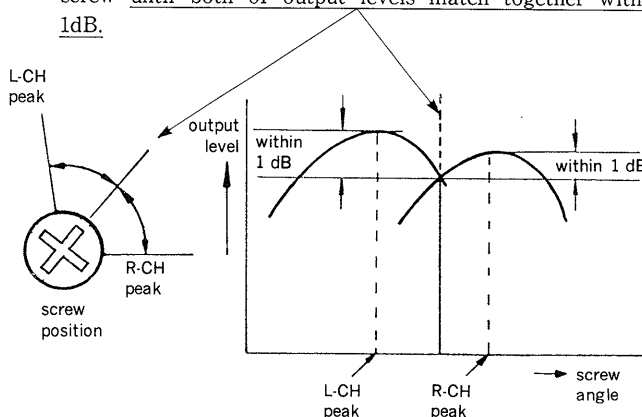

3. Phase Check

Playback mode
test tape
P-4-A100
(10kHz, -10dB)

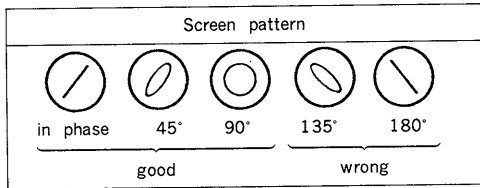
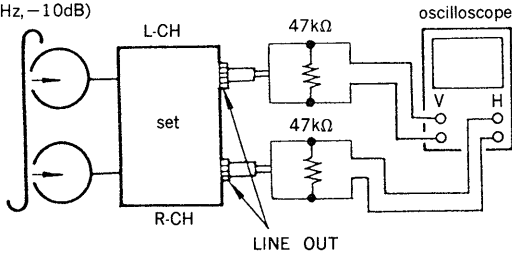

4. After the adjustment, lock the adjustment screw with suitable locking compound.

Adjustment Location: —record/playback head—

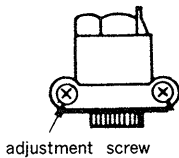

Tape Speed Adjustment

Procedure :

Playback Mode

test tape
WS-48B
(3kHz, 0dB)

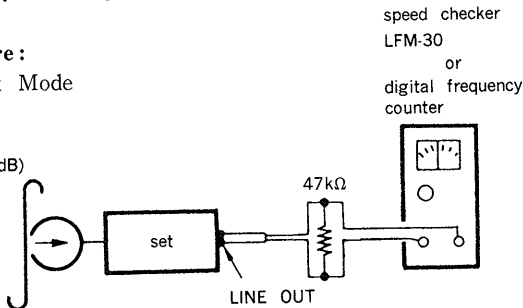

Specification :

Speed checker	Digital frequency counter
±0.5%	2,985—3,015Hz

Frequency difference between the beginning and the end of the tape should be within 0.5% (15Hz).

Adjustment Location :

adjustment the adjustable resistor of built in motor (adjustment by the insert to driver Speed in fastest that turn the clockwise.)

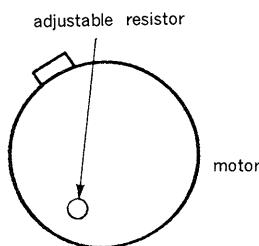

Playback Level Adjustment

Procedure :

Playback mode

test tape
P-4-L300
(315Hz, 0dB)

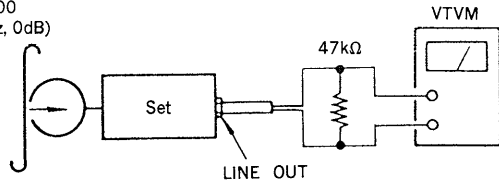

Specification :

Adjust RV101, 201 so that within adjustment level as follows.

LINE OUT level: 0.41 to 0.46V

(-5.5 to -4.5dB)

Level Difference between Channels: Within 0.5dB

Confirm the LINE OUT level does not change in playback mode while changing the mode from playback to stop several times.

Bias Consumption Current Adjustment

Bias Consumption current adjustment is sure to front of record bias adjustment.

Behind the bias consumption current adjustment, record bias adjustment do over again.

1. Connect CN514 with digital volt meter,
2. Adjust T151, 251 so that the minimum or digital volt meter.

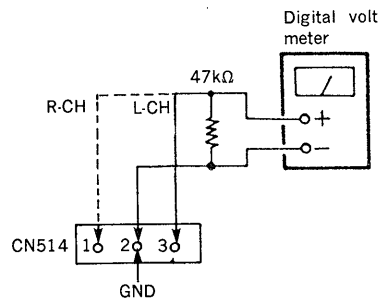

Record Bias Adjustent

Setting :

REC LEVEL knob shall be the specilied record position.

Procedure :

1. Record Mode

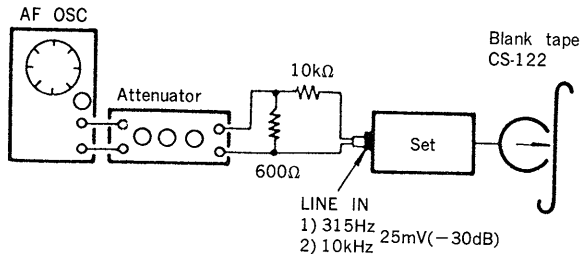

2. Playback Mode

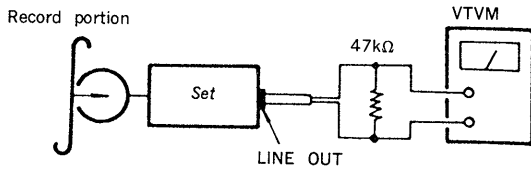

Adjust RV152, 252 so that playback output of 10kHz is 0.5 ± 0.3 dB.

Record Level Adjustment

Setting :

REC LEVEL knob shall be at the specified record position.

Procedure :

1. Record Mode

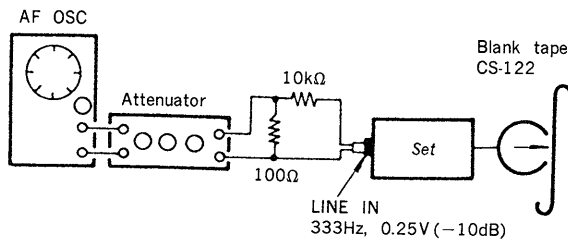

2. Playback Mode

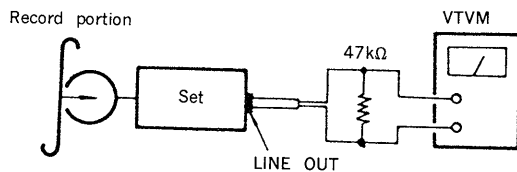

Specification :

Adjust RV151, 251 so that within adjustment level as follows.

LINE OUT Level: CS-122



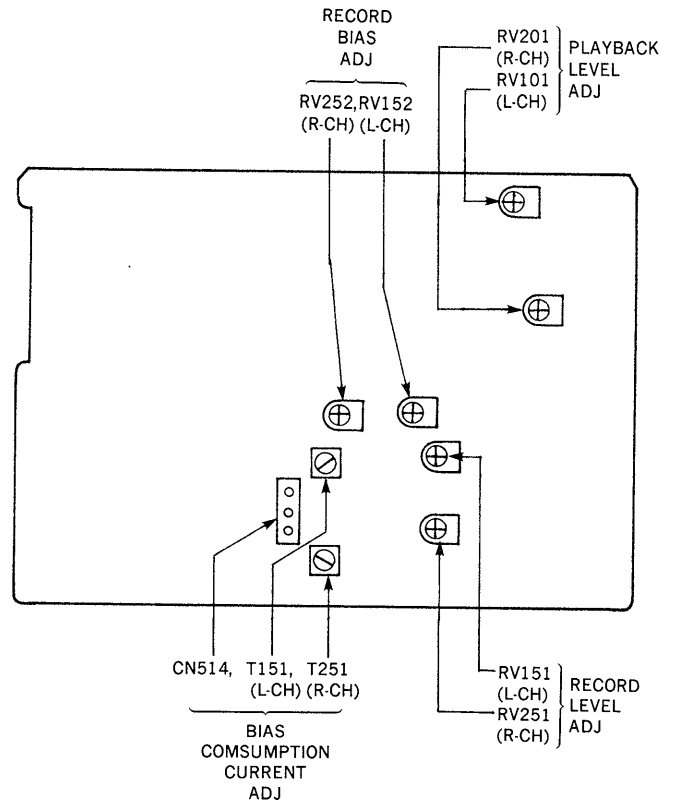

0.42 to 0.45V
(-5.3 to -4.7dB)

Adjustment Location : main board

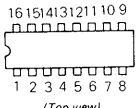
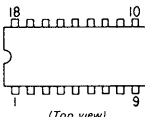
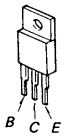
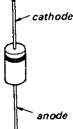
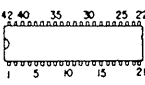

SECTION 4
DIAGRAMS

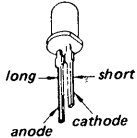
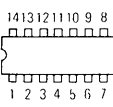
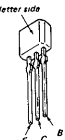
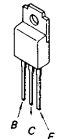
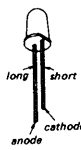
4-1. SEMICONDUCTOR LEAD LAYOUTS

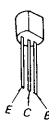
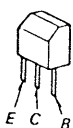
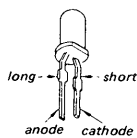
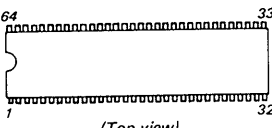
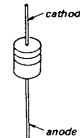
<p>CXA1198AP CX10034 M4019BP</p>  <p>(Top view)</p>	<p>μPC1297CA</p>  <p>(Top view)</p>	<p>2SB1094-L 2SD1585-L</p> 	<p>US1060M 10E2N</p> 
<p>CX20187 LC6520C-3901</p>  <p>(Top view)</p>	<p>DTA114ES DTA144ES DTB114ES DTC114ES DTC143TS DTC144ES 2SC634SP</p> 	<p>2SB1116</p> 	<p>GL-5HY41</p> 
<p>M4066BP M4071BP TC4069UBP</p>  <p>(Top view)</p>	<p>2SA1150 2SA1175 2SC2785</p> 	<p>2SD1761-E</p> 	<p>SEL1210S SEL1410E</p> 
<p>M5218P NJM2903D μPC4570C-1</p>  <p>(Top view)</p>	<p>2SA1409-L 2SB1013 2SC3623-L 2SD1387</p> 	<p>2SD774-3</p> 	<p>SEL2410E-C</p> 
<p>HD614042SA87</p>  <p>(Top view)</p>	<p>HZS6A1L HZS7B2L HZS7C1L HZS9C1L HZS12C1L</p> 		

● Semiconductor Location

Ref. No.	Location	Ref. No.	Location
D301	E-18	Q251	I-18
D351	F-13	Q252	I-22
D401	F-18	Q301	E-19
D451	F-13	Q401	F-19
D511	H-18	Q511	F-22
D512	F-21	Q512	F-22
D513	F-21	Q513	F-22
D514	F-24	Q514	I-22
D515	F-21	Q515	F-23
D516	F-21	Q516	F-23
D517	F-21	Q517	F-24
D701	C-26	Q518	G-24
D703	C-30	Q519	E-23
D704	C-29	Q520	E-22
D705	B-28	Q521	F-22
D706	B-29	Q551	F-20
D708	C-26	Q651	E-27
D709	C-26	Q652	E-27
D710	A-27	Q653	E-27
D711	C-26	Q654	F-26
D714	B-30	Q655	F-26
D715	B-26	Q701	C-30
D716	A-26	Q702	B-28
D717	B-26	Q703	B-29
D718	B-26	Q704	B-29
D715	C-23	Q705	B-27
D752	B-26	Q706	B-27
D753	B-26	Q707	B-30
D754	B-26	Q708	B-30
D755	B-26	Q709	B-30
D801	E-29	Q710	B-28
D802	H-25	Q751	B-24
D803	E-28	Q752	B-24
D804	E-28	Q753	B-23
D805	D-28	Q754	B-24
D806	C-28	Q755	C-23
D807	I-28	Q756	C-24
D808	J-28	Q757	C-24
D809	F-27	Q801	E-28
D901	E-9	Q802	F-28
D902	E-11	Q803	E-28
D903	E-10	Q804	H-27
D904	F-10	Q805	H-28
D905	F-11	Q806	H-28
D906	E-12	Q807	I-28
D907	E-12	Q808	I-28
		Q809	I-27
		Q810	I-28
IC501	C-18	Q811	J-28
IC502	C-20	Q812	I-29
IC511	H-19	Q901	G-7
IC512	H-21	Q902	G-7
IC513	G-23	Q903	G-6
IC551	F-20	Q904	G-6
IC552	E-18	Q905	G-7
IC553	F-16	Q906	G-8
IC651	E-26	Q907	G-13
IC801	G-28	Q908	G-11
IC802	I-26	Q909	F-12
IC803	I-29	Q910	F-11
IC804	H-29	Q1001	B-2
IC901	G-8	Q1002	B-5
IC902	F-13		
IC903	G-10		
Q101	B-19		
Q151	G-18		
Q152	F-22		
Q201	D-29		

4-2. PRINTED WIRING BOARDS

● See page 6 for semiconductor lead layouts.

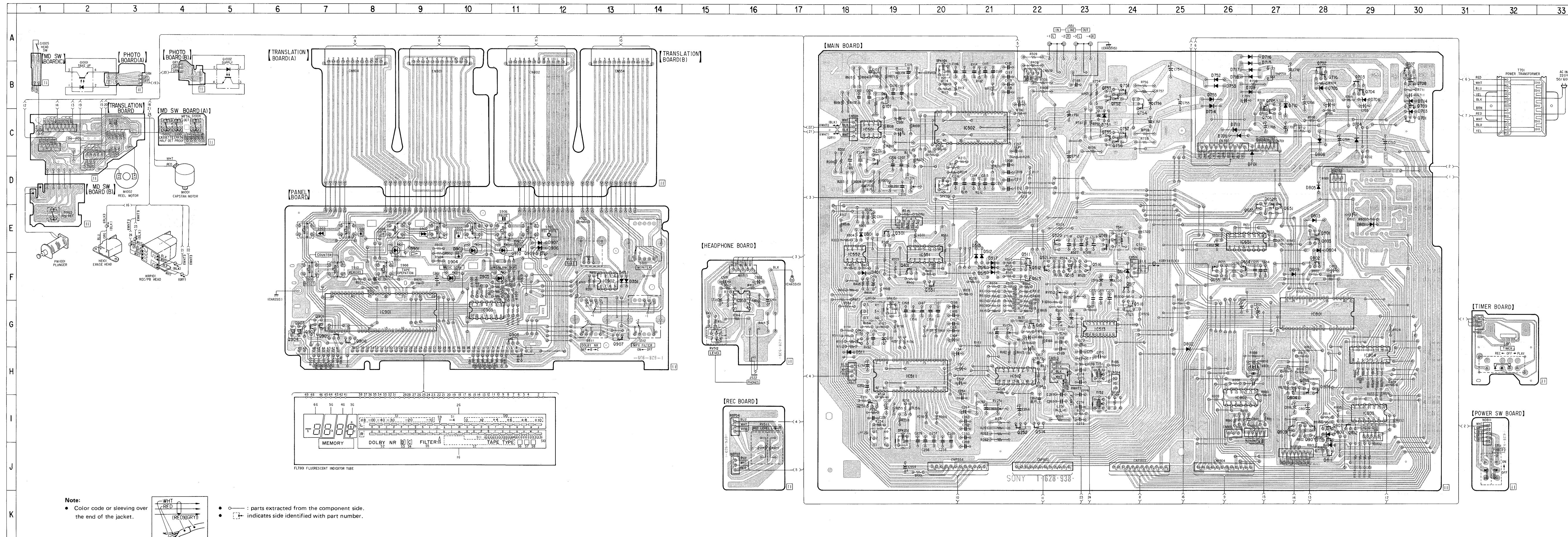

Note:

- Color code or sleeving over the end of the jacket.

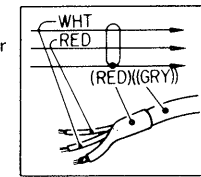

- : parts extracted from the component side.
- ⊕ : indicates side identified with part number.

4-4. SCHEMATIC DIAGRAM —DISPLAY SECTION—

• See page 15 for note for Display Section.

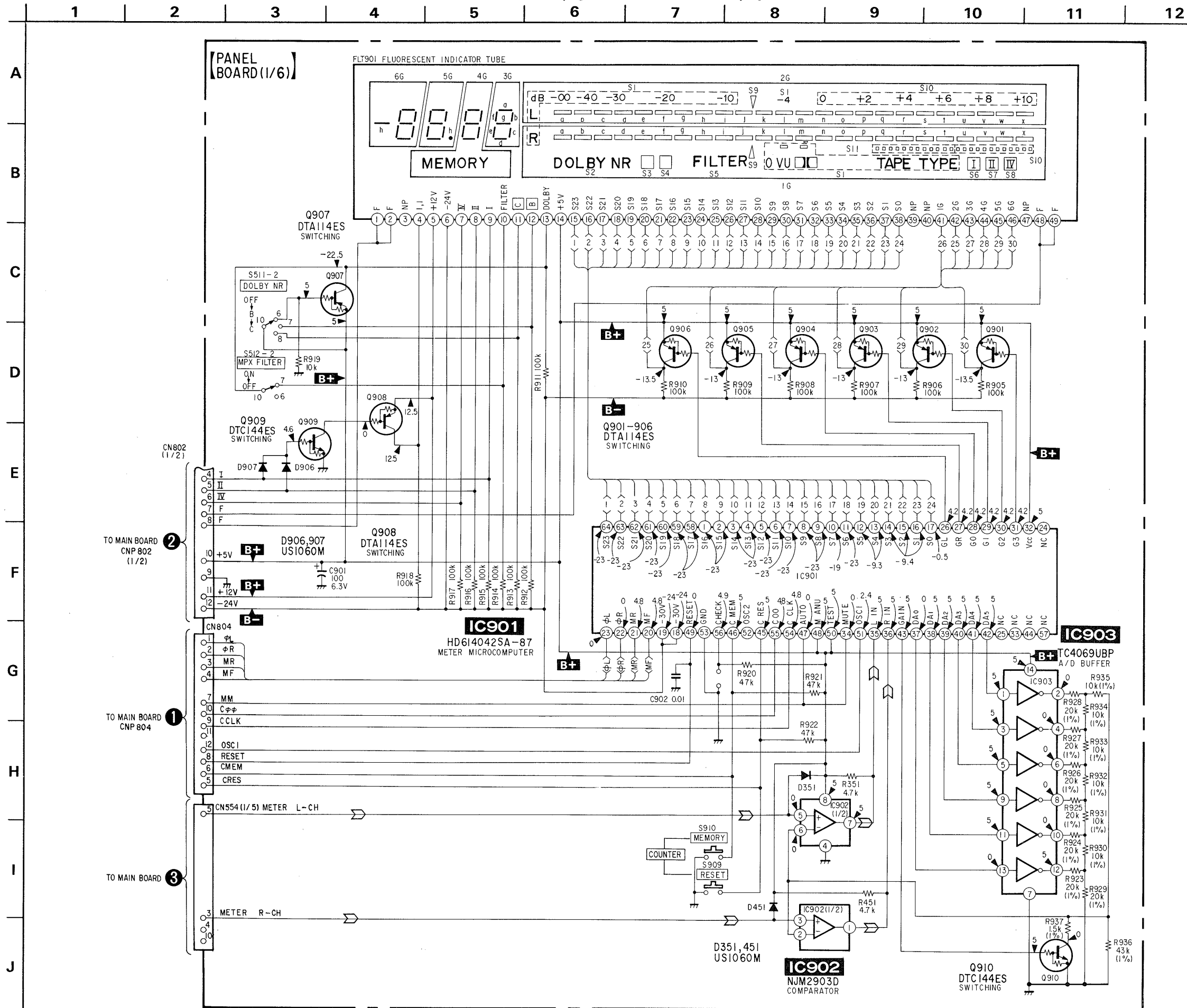

5-2. FRONT PANEL SECTION

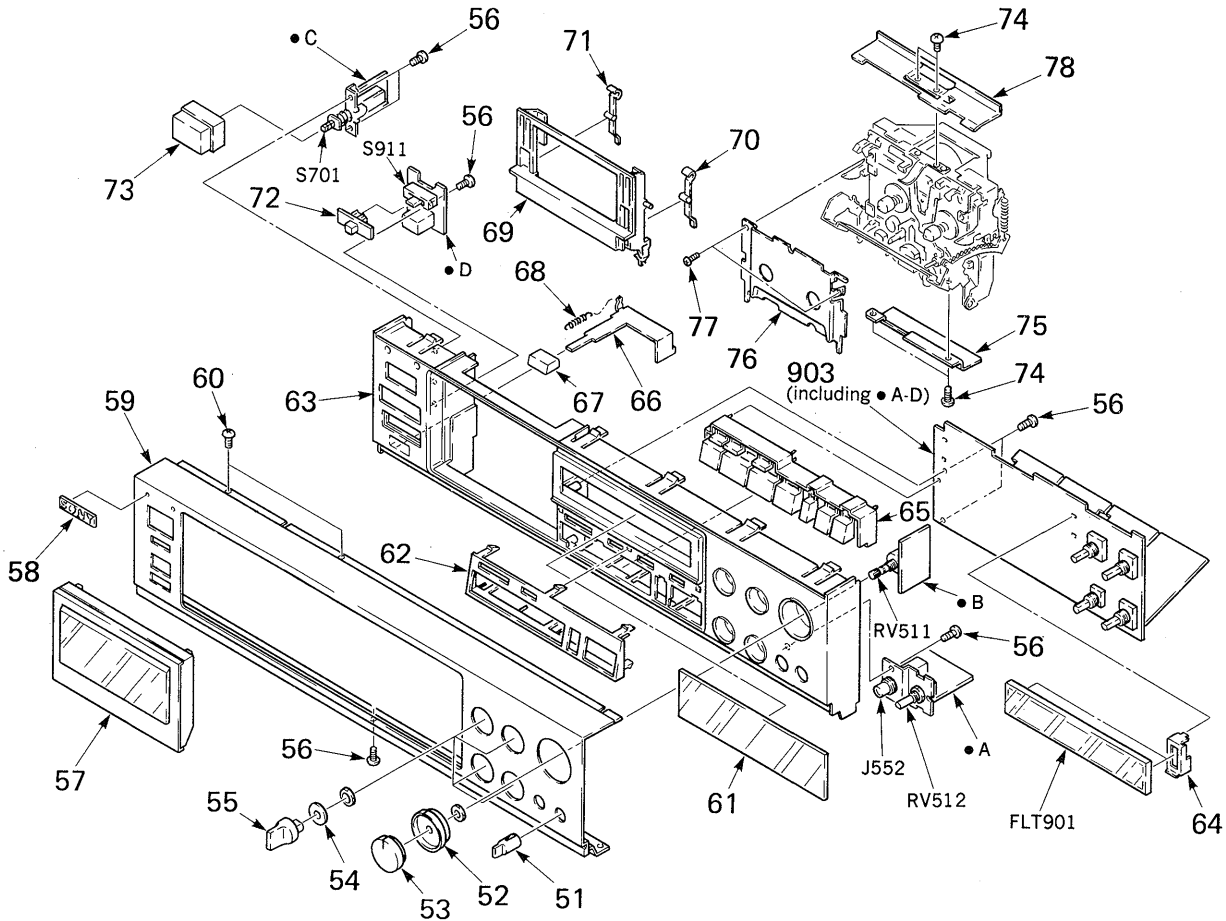

No.	Part No.	Description	Remarks	No.	Part No.	Description	Remarks
51	4-921-921-11	KNOB (M)		69	X-3332-448-1	HOLDER ASSY, CASSETTE	
52	3-332-589-01	KNOB (REC VOL-LEFT)		70	3-307-372-00	SPRING (RIGHT)	
53	3-332-590-01	KNOB (REC VOL-RIGHT)		71	3-307-371-00	SPRING (LEFT)	
54	3-350-416-01	SPACER		72	3-307-538-21	KNOB, SWITCH, TIMER	
55	4-908-097-21	KNOB		73	4-917-460-01	KNOB, POWER	
56	7-685-534-19	SCREW +BTP 2.6X8 TYPE2 N-S		74	7-682-147-01	SCREW +BVTT 3X6 (S)	
57	A-2169-137-A	LID ASSY, CASSETTE		75	*3-332-560-01	BRACKET (MDB)	
58	4-908-848-01	EMBLEM, SONY		76	*3-332-547-01	PLATE, ORNAMENTAL	
59	3-350-404-01	PANEL, FRONT		77	7-621-772-00	SCREW +B 2X3	
60	7-685-873-01	SCREW +BVTT 3X8		78	*3-332-561-01	BRACKET (MDU)	
61	3-318-698-01	WINDOW (M)		903	*A-2056-436-A	MOUNTED PCB, PANEL	
62	X-3304-941-1	PLATE (B) ASSY, ORNAMENTAL		FLT901	1-519-491-11	INDICATOR TUBE, FLUORESCENT	
63	3-350-405-01	PANEL (BASE)		J552	1-507-796-71	JACK (LARGE TYPE) (PHONES)	
64	*3-318-695-01	HOLDER (FL)		RV511	1-238-097-11	RES, VAR, CARBON 20K/20K (REC LEVEL)	
65	X-3304-939-1	BUTTON ASSY		RV512	1-238-085-11	RES, VAR, CARBON 20K/20K (PHONES LEVEL)	
66	*3-332-564-01	SLIDER (EJC)		S701	1-570-103-21	SWITCH, PUSH (1 KEY)(POWER)	
67	3-343-698-11	BUTTON (EJECT)		S911	1-554-208-00	SWITCH, SLIDE (TIMER)	
68	3-571-829-00	SPRING, TENSION					

5-3. MECHANISM SECTION ①
(TCM-CMAY B-27)

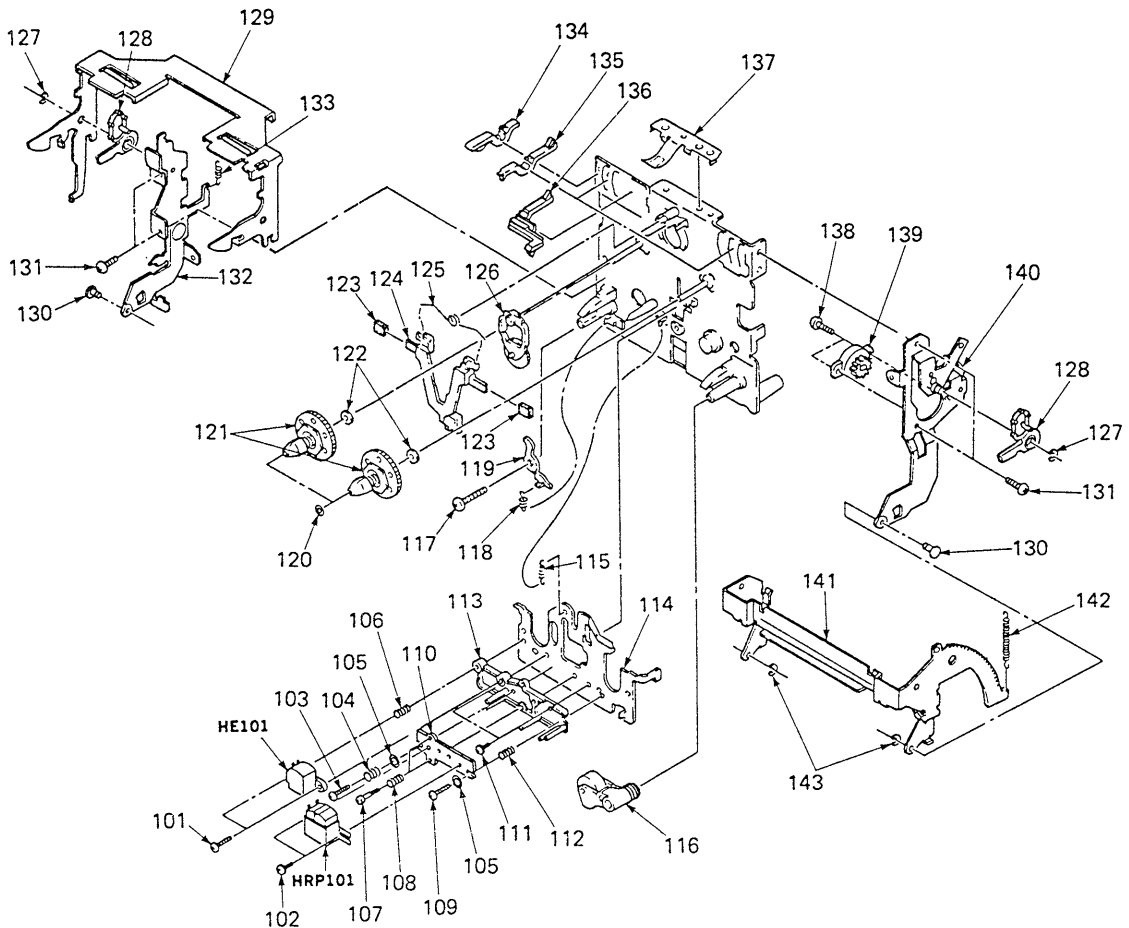

Ref.No	Part No.	Description	Remarks	Ref.No	Part No.	Description	Remarks
101	7-621-255-75	SCREW,TOTSU PWH 2X12		124	3-392-723-01	LEVER (B), HOLD	
102	7-621-255-15	SCREW +P 2X3		125	3-391-124-01	SPRING	
103	3-392-718-01	SCREW (M2X12) (SPECIAL), BIND		126	X-3391-111-1	IDLER ASSY	
104	3-392-716-01	SPRING (LEFT)		127	7-624-105-04	STOP RING 2.3, TYPE -E	
105	7-688-001-01	W 2, SMALL		128	3-391-185-01	LEVER, STOP	
106	3-391-101-01	SPRING		129	*3-391-180-01	ARM, EJECT	
107	3-392-719-01	SCREW, TILT		130	3-391-183-01	SHAFT (B), HOLDER FULCRUM	
108	3-392-715-01	SPRING		131	7-621-773-86	SCREW +PTT 2.6X4 (S)	
109	7-621-255-55	SCREW +P 2X3		132	*X-3391-152-1	ARM ASSY, EJECT	
110	*3-392-714-01	SPACER, 3 HEAD		133	3-391-181-01	SP, LEVER RETURN	
111	3-392-734-01	SCREW (2.0X3) (ZNT), 0 PAN		134	3-392-725-01	LEVER	
112	3-392-717-01	SPRING (RIGHT)		135	3-392-724-01	LEVER	
113	*3-392-713-01	PLATE, BASE HEAD		136	3-392-726-01	LEVER	
114	*3-392-712-01	BASE, HEAD		137	3-391-177-01	SPRING	
115	3-391-114-01	SPRING		138	7-621-255-15	SCREW +PTT 2X3 (S)	
116	3-392-731-01	PINCH ROLLER (R) ASSY		139	X-3391-151-1	DAMPER ASSY	
117	3-392-733-01	SCREW		140	*3-392-722-01	PLATE HOLD BLK	
118	3-391-122-01	SPRING (A)		141	*3-391-182-01	HOLDER, CASSETTE	
119	3-391-121-01	ARM, EJECT SAFETY		142	3-391-184-01	SPRING	
120	3-701-436-11	WASHER, 1.6 POLYETHYLENE		143	7-624-102-04	STOP RING 1.5, TYPE -E	
121	X-3391-107-1	REEL ASSY, T.U		HE101	1-543-375-11	HEAD, ERASE (EF-701-36)	
122	3-392-711-01	WASHER (2.1X0.25) (T)		HRP101	1-543-593-11	HEAD, MAGNETIC (REC/PB)	
123	3-392-728-01	RUBBER, BRAKE					

5-4. MECHANISM SECTION ②
(TCM-CMAY B-27)

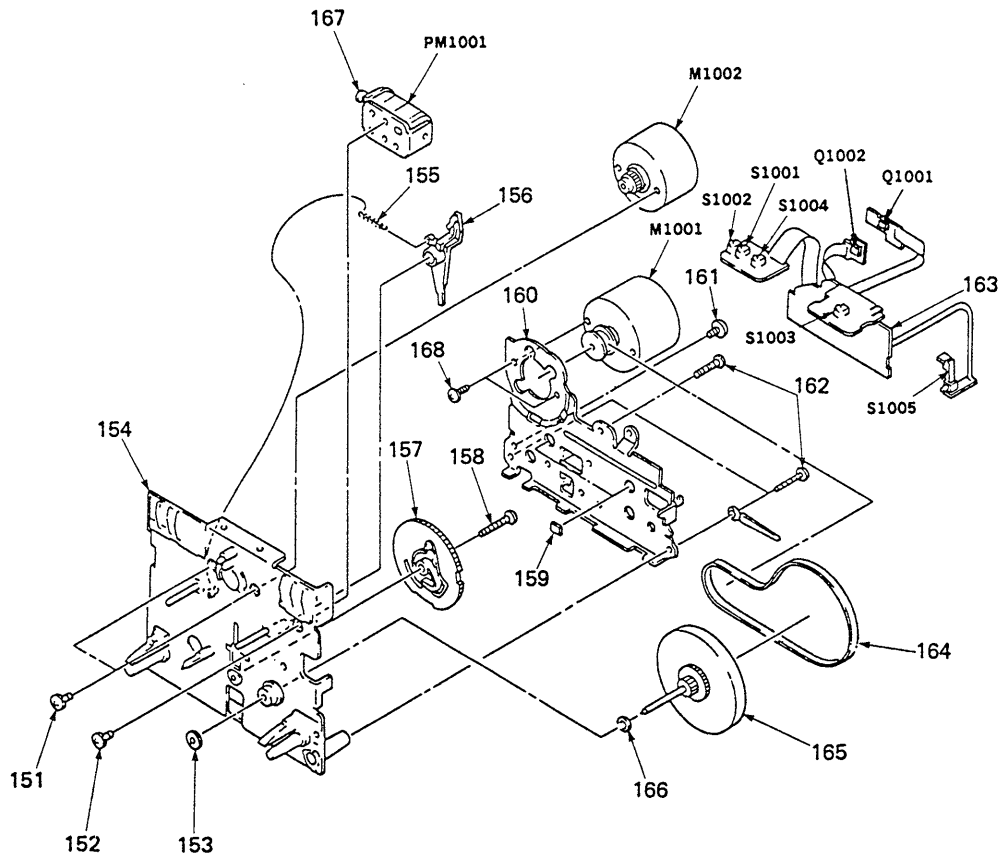

Ref.No	Part No.	Description	Remarks	Ref.No	Part No.	Description	Remarks
151	7-621-770-67	SCREW +P 2.6X6		165	X-3391-145-1	ASSY F/W	
152	7-621-759-25	+PSW, 2.6X4		166	3-701-438-11	WASHER	
153	3-391-119-01	SEAL, WASHER OIL		167	*3-392-707-01	SOLENOID (ARBOR)	
154	3-392-710-01	CHASSIS BASE BLK		168	7-628-253-90	SCREW +PS 2.6X4	
155	3-392-730-01	SP, PLAY ARM		M1001	X-3391-130-1	MOTOR ASSY	
156	3-392-727-01	ARM, PLAY		M1002	3-392-709-01	MTR REEL BLK	
157	3-391-197-01	GEAR (I), CAM		PM1001	1-454-440-11	SOLENOID, PLUNGER	
158	3-392-732-01	SCREW (2X15), TT, WASHER		Q1001	1-807-509-11	PHOTO SENSOR	
159	3-391-129-01	SPACER		Q1002	1-807-509-11	PHOTO SENSOR	
160	*3-392-720-01	F/W BKT		S1001	1-571-081-11	SWITCH	
161	7-682-546-04	SCREW +PTT 3X5 (S)		S1002	1-571-081-11	SWITCH	
162	7-685-131-19	SCREW +P 2.6X4 TYPE2 NON-SLIT		S1003	1-571-081-11	SWITCH	
163	*3-392-721-01	PCB CONTROL BLK		S1004	1-571-081-11	SWITCH	
164	3-392-729-01	BELT, MAIN		S1005	1-571-820-11	SWITCH, LEAF	

SECTION 6 ELECTRICAL PARTS LIST

NOTE:

- Due to standardization, replacements in the parts list may be different from the parts specified in the diagrams or the components used on the set.
- Items marked "★" are not stocked since they are seldom required for routine service. Some delay should be anticipated when ordering these items.
- If there are two or more same circuits in a set such as a stereophonic machine, only typical circuit parts may be indicated and capacitors and resistors in other same circuits may be omitted.

CAPACITORS:

MF: μ F, PF: μ μ F.

RESISTORS

- All resistors are in ohms.
- F: nonflammable

COILS

- MMH: mH, UH: μ H

SEMICONDUCTORS

In each case, U: μ , for example:

UA....: μ A..., UPA....: μ PA...,
UPC....: μ PC, UPD....: μ PD...

The components identified by mark or dotted line with mark are critical for safety. Replace only with part number specified.

Ref.No.	Part No.	Description	Ref.No.	Part No.	Description						
901	*A-2056-433-A	MOUNTED PCB, MAIN	C311	1-123-875-11	ELECT	10MF	20%	50V			
902	1-555-795-00	CORD, POWER, EULO PLUG	C501	1-123-875-11	FLECT	10MF	20%	50V			
903	*A-2056-436-A	MOUNTED PCB, PANEL	C502	1-123-875-11	ELECT	10MF	20%	50V			
C102	1-130-973-00	FILM	0.022MF	5%	100V	C511	1-126-176-11	ELECT	220MF	20%	10V
C103	1-124-657-00	ELECT	10MF	20%	50V	C512	1-126-176-11	ELECT	220MF	20%	10V
C104	1-130-488-00	MYLAR	0.027MF	5%	50V	C513	1-124-925-11	ELECT	2.2MF	20%	50V
C105	1-102-966-00	CERAMIC	43PF	5%	50V	C514	1-124-477-11	ELECT	47MF	20%	16V
C106	1-130-474-00	MYLAR	0.0018MF	5%	50V	C515	1-124-477-11	ELECT	47MF	20%	16V
C107	1-130-474-00	MYLAR	0.0018MF	5%	50V	C516	1-124-902-00	ELECT	0.47MF	20%	50V
C108	1-136-153-00	FILM	0.01MF	5%	50V	C517	1-136-253-11	FILM	0.0018MF	5%	100V
C109	1-130-481-00	MYLAR	0.0068MF	5%	50V	C518	1-136-253-11	FILM	0.0018MF	5%	100V
C110	1-136-161-00	FILM	0.047MF	5%	50V	C519	1-136-233-11	FILM	0.0047MF	5%	100V
C111	1-136-163-00	FILM	0.068MF	5%	50V	C520	1-126-233-11	ELECT	22MF	20%	50V
C112	1-136-169-00	FILM	0.22MF	5%	50V	C521	1-107-045-00	MICA	3.9PF	0.5PF	500V
C113	1-136-155-00	FILM	0.015MF	5%	50V	C522	1-136-558-11	FILM	0.0039MF	5%	630V
C114	1-136-167-00	FILM	0.15MF	5%	50V	C551	1-124-477-11	ELECT	47MF	20%	16V
C115	1-136-173-00	FILM	0.47MF	5%	50V	C552	1-124-477-11	ELECT	47MF	20%	16V
C116	1-130-479-00	MYLAR	0.0047MF	5%	50V	C553	1-130-487-00	MYLAR	0.022MF	5%	50V
C117	1-124-657-00	ELECT	10MF	20%	50V	C554	1-124-925-11	ELECT	2.2MF	20%	50V
C151	1-130-475-00	MYLAR	0.0022MF	5%	50V	C651	1-136-166-00	FILM	0.12MF	5%	50V
C152	1-124-927-11	ELECT	4.7MF	20%	50V	C652	1-124-499-11	ELECT	1MF	20%	50V
C153	1-124-927-11	ELECT	4.7MF	20%	50V	C653	1-162-294-31	CERAMIC	0.001MF	10%	50V
C154	1-124-657-00	ELECT	10MF	20%	50V	C654	1-162-294-31	CERAMIC	0.001MF	10%	50V
C155	1-130-479-00	MYLAR	0.0047MF	5%	50V	C655	1-136-165-00	FILM	0.1MF	5%	50V
C156	1-136-173-00	FILM	0.47MF	5%	50V	C656	1-136-166-00	FILM	0.12MF	5%	50V
C157	1-136-167-00	FILM	0.15MF	5%	50V	C701	1-124-446-11	ELECT	47MF	20%	10V
C158	1-136-155-00	FILM	0.015MF	5%	50V	C702	1-124-122-11	ELECT	100MF	20%	50V
C159	1-136-169-00	FILM	0.22MF	5%	50V	C703	1-124-927-11	ELECT	4.7MF	20%	50V
C160	1-136-163-00	FILM	0.068MF	5%	50V	C704	1-124-893-11	ELECT	2200MF	20%	6.3V
C161	1-136-161-00	FILM	0.047MF	5%	50V	C705	1-124-122-11	ELECT	100MF	20%	50V
C162	1-130-481-00	MYLAR	0.0068MF	5%	50V	C706	1-124-898-11	ELECT	4700MF	20%	16V
C163	1-136-153-00	FILM	0.01MF	5%	50V	C709	1-124-927-11	ELECT	4.7MF	20%	50V
C164	1-126-233-11	ELECT	22MF	20%	50V	C710	1-124-887-00	ELECT	3300MF	20%	16V
C165	1-124-499-11	ELECT	1MF	20%	50V	C711	1-124-927-11	ELECT	4.7MF	20%	50V
C166	1-124-927-11	ELECT	4.7MF	20%	50V	C712	1-124-618-11	ELECT	2200MF	20%	35V
C167	1-124-657-00	ELECT	10MF	20%	50V	C751	1-124-557-11	ELECT	1000MF	20%	25V
C168	1-162-285-31	CERAMIC	180PF	10%	50V	C752	1-124-557-11	ELECT	1000MF	20%	25V
C169	1-107-210-00	MICA	22PF	5%	500V	C753	1-124-443-00	ELECT	100MF	20%	10V
C170	1-136-165-00	FILM	0.1MF	5%	50V	C754	1-124-563-11	ELECT	2200MF	20%	25V
C171	1-136-157-00	FILM	0.022MF	5%	50V	C755	1-124-563-11	ELECT	2200MF	20%	25V
C172	1-136-153-00	FILM	0.01MF	5%	50V	C756	1-126-101-11	ELECT	100MF	20%	16V
C173	1-130-468-00	MYLAR	560PF	5%	50V	C757	1-126-101-11	ELECT	100MF	20%	16V
C174	1-136-433-11	FILM	100PF	5%	630V	C802	1-124-927-11	ELECT	4.7MF	20%	50V
C175	1-136-803-11	FILM	560PF	5%	630V	C803	1-124-472-11	ELECT	470MF	20%	6.3V
C301	1-123-382-00	ELECT	3.3MF	20%	50V	C804	1-124-927-11	ELECT	4.7MF	20%	50V

Ref.No.	Part No.	Description					Ref.No.	Part No.	Description
C805	1-124-443-00	ELECT	100MF	20%	10V		D805	8-719-000-26	DIODE US1060M
C806	1-124-446-11	ELECT	47MF	20%	10V		D806	8-719-200-77	DIODE 10E2N
C807	1-124-446-11	ELECT	47MF	20%	10V		D807	8-719-000-26	DIODE US1060M
C808	1-162-294-31	CERAMIC	0.001MF	10%	50V		D808	8-719-000-26	DIODE US1060M
C809	1-162-294-31	CERAMIC	0.001MF	10%	50V		D809	8-719-000-26	DIODE US1060M
C901	1-123-661-00	ELECT	100MF	20%	6.3V		D901	8-719-305-52	DIODE SEL1410E
C902	1-161-379-00	CERAMIC	0.01MF	30%	16V		D902	8-719-941-46	DIODE GL-5HY41
CN501	*1-564-507-11	PLUG, CONNECTOR	4P				D903	8-719-302-45	DIODE SEL1210S
CN513	*1-564-507-11	PLUG, CONNECTOR	4P				D904	8-719-301-43	DIODE SEL2410E-C
CN514	*1-564-506-11	PLUG, CONNECTOR	3P				D905	8-719-301-43	DIODE SEL2410E-C
CN516	*1-564-506-11	PLUG, CONNECTOR	3P				D906	8-719-000-26	DIODE US1060M
CN551	*1-564-508-11	PLUG, CONNECTOR	5P				D907	8-719-000-26	DIODE US1060M
CN552	*1-564-506-11	PLUG, CONNECTOR	3P				FLT901	1-519-491-11	INDICATOR TUBE, FLUORESCENT
CN553	*1-564-506-11	PLUG, CONNECTOR	3P				IC501	8-759-111-44	IC UPC4570C-1
CN554	*1-566-827-11	SOCKET, CONNECTOR	12P				IC502	8-752-018-70	IC CX20187
CN701	*1-564-339-00	PIN, CONNECTOR	5P				IC511	8-752-018-70	IC CX20187
CN702	*1-564-513-11	PLUG, CONNECTOR	10P				IC512	8-752-033-61	IC CXA1198AP
CN801	*1-564-337-00	PIN, CONNECTOR	3P				IC513	8-759-106-56	IC UPC1297CA
CN802	*1-566-827-11	SOCKET, CONNECTOR	12P				IC551	8-759-601-43	IC M4066BP
CN803	*1-566-827-11	SOCKET, CONNECTOR	12P				IC552	8-759-601-02	IC M5218P
CN804	*1-566-827-11	SOCKET, CONNECTOR	12P				IC553	8-759-601-02	IC M5218P
CN805	*1-564-506-11	PLUG, CONNECTOR	3P				IC651	8-759-700-46	IC CX10034
CNP554	*1-566-826-11	PLUG, CONNECTOR	12P				IC801	8-759-821-29	IC LC6520C-3901
CNP802	*1-566-826-11	PLUG, CONNECTOR	12P				IC802	8-759-240-69	IC TC4069UBP
CNP803	*1-566-826-11	PLUG, CONNECTOR	12P				IC803	8-759-240-71	IC M4071BP
CNP804	*1-566-826-11	PLUG, CONNECTOR	12P				IC804	8-759-601-19	IC M4019BP
D301	8-719-000-26	DIODE	US1060M				IC901	8-759-302-98	IC HD614042SA87
D351	8-719-000-26	DIODE	US1060M				IC902	8-759-729-03	IC NJM2903D
D401	8-719-000-26	DIODE	US1060M				IC903	8-759-240-69	IC TC4069UBP
D451	8-719-000-26	DIODE	US1060M				J551	1-565-258-21	JACK, PIN 4P (LINE IN/OUT)
D511	8-719-000-26	DIODE	US1060M				J552	1-507-796-71	JACK (LARGE TYPE) (PHONES)
D512	8-719-000-26	DIODE	US1060M				L101	1-410-779-21	INDUCTOR 22MMH
D513	8-719-000-26	DIODE	US1060M				L151	1-410-780-11	INDUCTOR 27MMH
D514	8-719-000-26	DIODE	US1060M				L201	1-410-779-21	INDUCTOR 22MMH
D515	8-719-000-26	DIODE	US1060M				L251	1-410-780-11	INDUCTOR 27MMH
D516	8-719-000-26	DIODE	US1060M				LPF151	1-235-980-11	FILTER, LOW PASS
D517	8-719-000-26	DIODE	US1060M				LPF251	1-235-980-11	FILTER, LOW PASS
D701	8-719-933-49	DIODE	HZS7C1L				Q101	8-729-107-77	TRANSISTOR 2SC3623-L
D703	8-719-933-47	DIODE	HZS7B2L				Q151	8-729-178-54	TRANSISTOR 2SC2785
D704	8-719-933-49	DIODE	HZS7C1L				Q152	8-729-107-77	TRANSISTOR 2SC3623-L
D705	8-719-933-59	DIODE	HZS9C1L				Q201	8-729-107-77	TRANSISTOR 2SC3623-L
D706	8-719-933-47	DIODE	HZS7B2L				Q251	8-729-178-54	TRANSISTOR 2SC2785
D708	8-719-000-26	DIODE	US1060M				Q252	8-729-107-77	TRANSISTOR 2SC3623-L
D709	8-719-200-77	DIODE	10E2N				Q301	8-729-107-77	TRANSISTOR 2SC3623-L
D710	8-719-200-77	DIODE	10E2N				Q401	8-729-107-77	TRANSISTOR 2SC3623-L
D711	8-719-200-77	DIODE	10E2N				Q511	8-729-107-77	TRANSISTOR 2SC3623-L
D714	8-719-933-79	DIODE	HZS12C1L				Q512	8-729-107-77	TRANSISTOR 2SC3623-L
D715	8-719-200-77	DIODE	10E2N				Q513	8-729-107-77	TRANSISTOR 2SC3623-L
D716	8-719-200-77	DIODE	10E2N				Q514	8-729-900-61	TRANSISTOR DTA114ES
D717	8-719-200-77	DIODE	10E2N				Q515	8-729-900-80	TRANSISTOR DTC114ES
D718	8-719-200-77	DIODE	10E2N				Q516	8-729-900-80	TRANSISTOR DTC114ES
D751	8-719-933-33	DIODE	HZS6A1L				Q517	8-729-117-54	TRANSISTOR 2SA1175
D752	8-719-200-77	DIODE	10E2N				Q518	8-729-900-80	TRANSISTOR DTC114ES
D753	8-719-200-77	DIODE	10E2N				Q519	8-729-600-27	TRANSISTOR 2SC634SP
D754	8-719-200-77	DIODE	10E2N				Q520	8-729-600-27	TRANSISTOR 2SC634SP
D755	8-719-200-77	DIODE	10E2N						
D801	8-719-000-26	DIODE	US1060M						
D802	8-719-000-26	DIODE	US1060M						
D803	8-719-200-77	DIODE	10E2N						
D804	8-719-000-26	DIODE	US1060M						

Ref.No.	Part No.	Description			
Q521	8-729-900-80	TRANSISTOR DTC114ES			
Q551	8-729-900-89	TRANSISTOR DTC144ES			
Q651	8-729-920-26	TRANSISTOR DTB114ES			
Q652	8-729-920-26	TRANSISTOR DTB114ES			
Q653	8-729-920-26	TRANSISTOR DTB114ES			
Q654	8-729-900-80	TRANSISTOR DTC114ES			
Q655	8-729-900-80	TRANSISTOR DTC114ES			
Q701	8-729-900-80	TRANSISTOR DTC114ES			
Q702	8-729-904-27	TRANSISTOR 2SD1761-E			
Q703	8-729-904-27	TRANSISTOR 2SD1761-E			
Q704	8-729-178-54	TRANSISTOR 2SC2785			
Q705	8-729-110-69	TRANSISTOR 2SA1409			
Q706	8-729-118-01	TRANSISTOR 2SB1116			
Q707	8-729-904-27	TRANSISTOR 2SD1761-E			
Q708	8-729-107-77	TRANSISTOR 2SC3623-L			
Q709	8-729-900-74	TRANSISTOR DTC143TS			
Q710	8-729-178-54	TRANSISTOR 2SC2785			
Q751	8-729-107-25	TRANSISTOR 2SD1585-L			
Q752	8-729-178-54	TRANSISTOR 2SC2785			
Q753	8-729-178-54	TRANSISTOR 2SC2785			
Q754	8-729-900-74	TRANSISTOR DTC143TS			
Q755	8-729-117-54	TRANSISTOR 2SA1175			
Q756	8-729-117-54	TRANSISTOR 2SA1175			
Q757	8-729-111-67	TRANSISTOR 2SB1094-L			
Q801	8-729-900-65	TRANSISTOR DTA144ES			
Q802	8-729-900-65	TRANSISTOR DTA144ES			
Q803	8-729-900-65	TRANSISTOR DTA144ES			
Q804	8-729-177-42	TRANSISTOR 2SD774-3			
Q805	8-729-801-83	TRANSISTOR 2SB1013			
Q806	8-729-801-83	TRANSISTOR 2SB1013			
Q807	8-729-205-02	TRANSISTOR 2SA1150			
Q808	8-729-801-83	TRANSISTOR 2SB1013			
Q809	8-729-801-93	TRANSISTOR 2SD1387			
Q810	8-729-801-93	TRANSISTOR 2SD1387			
Q811	8-729-801-83	TRANSISTOR 2SB1013			
Q812	8-729-900-61	TRANSISTOR DTA114ES			
Q901	8-729-900-61	TRANSISTOR DTA114ES			
Q902	8-729-900-61	TRANSISTOR DTA114ES			
Q903	8-729-900-61	TRANSISTOR DTA114ES			
Q904	8-729-900-61	TRANSISTOR DTA114ES			
Q905	8-729-900-61	TRANSISTOR DTA114ES			
Q906	8-729-900-61	TRANSISTOR DTA114ES			
Q907	8-729-900-61	TRANSISTOR DTA114ES			
Q908	8-729-900-61	TRANSISTOR DTA114ES			
Q909	8-729-900-89	TRANSISTOR DTC144ES			
Q910	8-729-900-89	TRANSISTOR DTC144ES			
R101	1-249-590-11	CARBON	39K	5%	1/4W
R102	1-247-700-11	CARBON	100	5%	1/4W
R103	1-249-603-11	CARBON	130K	5%	1/4W
R104	1-247-722-11	CARBON	5.6K	5%	1/4W
R105	1-247-716-11	CARBON	1.8K	5%	1/4W
R106	1-247-138-00	CARBON	2K	5%	1/4W
R107	1-247-887-00	CARBON	220K	5%	1/4W
R108	1-249-429-11	CARBON	10K	5%	1/4W
R109	1-249-431-11	CARBON	15K	5%	1/4W
R110	1-247-717-11	CARBON	2.2K	5%	1/4W
R111	1-249-415-11	CARBON	680	5%	1/4W
R112	1-249-427-11	CARBON	6.8K	5%	1/4W

Ref.No.	Part No.	Description			
R113	1-259-419-11	CARBON	430	5%	1/6W
R114	1-259-437-11	CARBON	2.4K	5%	1/6W
R115	1-259-443-11	CARBON	4.3K	5%	1/6W
R116	1-249-441-11	CARBON	100K	5%	1/4W
R117	1-249-429-11	CARBON	10K	5%	1/4W
R151	1-249-421-11	CARBON	2.2K	5%	1/4W
R152	1-249-441-11	CARBON	100K	5%	1/4W
R153	1-249-441-11	CARBON	100K	5%	1/4W
R154	1-249-423-11	CARBON	3.3K	5%	1/4W
R155	1-249-428-11	CARBON	8.2K	5%	1/4W
R156	1-259-419-11	CARBON	430	5%	1/6W
R157	1-259-443-11	CARBON	4.3K	5%	1/6W
R158	1-259-437-11	CARBON	2.4K	5%	1/6W
R159	1-249-427-11	CARBON	6.8K	5%	1/4W
R160	1-249-415-11	CARBON	680	5%	1/4W
R161	1-247-722-11	CARBON	5.6K	5%	1/4W
R162	1-249-561-11	CARBON	2.4K	5%	1/4W
R163	1-247-725-11	CARBON	10K	5%	1/4W
R164	1-249-417-11	CARBON	1K	5%	1/4W
R165	1-249-469-11	CARBON	100K	5%	1/4W
R166	1-247-721-11	CARBON	4.7K	5%	1/4W
R167	1-249-435-11	CARBON	33K	5%	1/4W
R168	1-249-432-11	CARBON	18K	5%	1/4W
R169	1-249-393-11	CARBON	10	5%	1/4W
R170	1-247-883-00	CARBON	150K	5%	1/4W
R171	1-247-725-11	CARBON	10K	5%	1/4W
R301	1-259-436-11	CARBON	2.2K	5%	1/6W
R302	1-249-421-11	CARBON	2.2K	5%	1/4W
R303	1-215-453-00	METAL	22K	1%	1/6W
R304	1-215-457-00	METAL	33K	1%	1/6W
R305	1-249-408-11	CARBON	180	5%	1/4W
R306	1-249-436-11	CARBON	39K	5%	1/4W
R307	1-249-429-11	CARBON	10K	5%	1/4W
R308	1-247-713-11	CARBON	1K	5%	1/4W
R309	1-249-497-11	CARBON	33K	5%	1/4W
R311	1-249-433-11	CARBON	22K	5%	1/4W
R312	1-249-421-11	CARBON	2.2K	5%	1/4W
R313	1-247-862-11	CARBON	20K	5%	1/4W
R314	1-247-704-11	CARBON	220	5%	1/4W
R315	1-215-453-00	METAL	22K	1%	1/6W
R316	1-215-454-00	METAL	24K	1%	1/6W
R351	1-249-425-11	CARBON	4.7K	5%	1/4W
R451	1-249-425-11	CARBON	4.7K	5%	1/4W
R503	1-249-437-11	CARBON	47K	5%	1/4W
R504	1-215-469-00	METAL	100K	1%	1/6W
R511	1-249-429-11	CARBON	10K	5%	1/4W
R512	1-249-437-11	CARBON	47K	5%	1/4W
R513	1-249-437-11	CARBON	47K	5%	1/4W
R514	1-215-469-00	METAL	100K	1%	1/6W
R515	1-249-429-11	CARBON	10K	5%	1/4W
R516	1-249-429-11	CARBON	10K	5%	1/4W
R517	1-249-429-11	CARBON	10K	5%	1/4W
R519	1-247-864-11	CARBON	24K	5%	1/4W
R520	1-249-441-11	CARBON	100K	5%	1/4W
R521	1-249-421-11	CARBON	2.2K	5%	1/4W
R522	1-249-427-11	CARBON	6.8K	5%	1/4W
R523	1-249-437-11	CARBON	47K	5%	1/4W

Ref.No.	Part No.	Description			
R524	1-249-426-11	CARBON	5.6K	5%	1/4W
R525	1-247-840-00	CARBON	2.4K	5%	1/4W
R526	1-249-425-11	CARBON	4.7K	5%	1/4W
R527	1-249-440-11	CARBON	82K	5%	1/4W
R528	1-249-440-11	CARBON	82K	5%	1/4W
R529	1-249-390-11	CARBON	5.6	5%	1/4W
R530	1-249-429-11	CARBON	10K	5%	1/4W
R531	1-249-429-11	CARBON	10K	5%	1/4W
R532	1-249-431-11	CARBON	15K	5%	1/4W
R533	1-249-434-11	CARBON	27K	5%	1/4W
R534	1-249-439-11	CARBON	68K	5%	1/4W
R551	1-249-437-11	CARBON	47K	5%	1/4W
R552	1-249-437-11	CARBON	47K	5%	1/4W
R553	1-249-429-11	CARBON	10K	5%	1/4W
R554	1-249-421-11	CARBON	2.2K	5%	1/4W
R555	1-249-409-11	CARBON	220	5%	1/4W
R601	1-249-439-11	CARBON	68K	5%	1/4W
R602	1-247-874-11	CARBON	62K	5%	1/4W
R603	1-247-880-11	CARBON	110K	5%	1/4W
R604	1-247-876-11	CARBON	75K	5%	1/4W
R605	1-249-435-11	CARBON	33K	5%	1/4W
R606	1-247-870-11	CARBON	43K	5%	1/4W
R607	1-247-887-00	CARBON	220K	5%	1/4W
R608	1-249-439-11	CARBON	68K	5%	1/4W
R609	1-249-440-11	CARBON	82K	5%	1/4W
R610	1-249-441-11	CARBON	100K	5%	1/4W
R611	1-249-437-11	CARBON	47K	5%	1/4W
R612	1-249-439-11	CARBON	68K	5%	1/4W
R613	1-247-881-00	CARBON	120K	5%	1/4W
R614	1-249-441-11	CARBON	100K	5%	1/4W
R615	1-249-437-11	CARBON	47K	5%	1/4W
R616	1-249-438-11	CARBON	56K	5%	1/4W
R617	1-247-872-11	CARBON	51K	5%	1/4W
R618	1-247-876-11	CARBON	75K	5%	1/4W
R651	1-249-425-11	CARBON	4.7K	5%	1/4W
R652	1-249-405-11	CARBON	100	5%	1/4W
R653	1-249-435-11	CARBON	33K	5%	1/4W
R654	1-249-425-11	CARBON	4.7K	5%	1/4W
R655	1-249-427-11	CARBON	6.8K	5%	1/4W
R701	1-249-413-11	CARBON	470	5%	1/4W
R702	1-249-425-11	CARBON	4.7K	5%	1/4W
R703	1-249-429-11	CARBON	10K	5%	1/4W
R704	1-249-421-11	CARBON	2.2K	5%	1/4W
R705	1-249-421-11	CARBON	2.2K	5%	1/4W
R706	1-249-426-11	CARBON	5.6K	5%	1/4W

Ref.No.	Part No.	Description			
R707	1-249-429-11	CARBON	10K	5%	1/4W
R708	1-249-433-11	CARBON	22K	5%	1/4W
R709	1-247-752-11	CARBON	1K	5%	1/2W
R710	1-249-417-11	CARBON	1K	5%	1/4W
R711	1-249-425-11	CARBON	4.7K	5%	1/4W
R712	1-249-426-11	CARBON	5.6K	5%	1/4W
R751	1-247-710-11	CARBON	560	5%	1/4W
R752	1-247-714-11	CARBON	1.2K	5%	1/4W
R753	1-247-704-11	CARBON	220	5%	1/4W
R754	1-247-725-11	CARBON	10K	5%	1/4W
R755	1-247-708-11	CARBON	470	5%	1/4W
R756	1-247-717-11	CARBON	2.2K	5%	1/4W
R757	1-247-717-11	CARBON	2.2K	5%	1/4W
R758	1-247-717-11	CARBON	2.2K	5%	1/4W
R759	1-247-717-11	CARBON	2.2K	5%	1/4W
R801	1-249-441-11	CARBON	100K	5%	1/4W
R802	1-249-425-11	CARBON	4.7K	5%	1/4W
R803	1-249-441-11	CARBON	100K	5%	1/4W
R805	1-249-437-11	CARBON	47K	5%	1/4W
R806	1-247-903-00	CARBON	1M	5%	1/4W
R807	1-247-887-00	CARBON	220K	5%	1/4W
R808	1-247-887-00	CARBON	220K	5%	1/4W
R809	1-249-435-11	CARBON	33K	5%	1/4W
R810	1-249-435-11	CARBON	33K	5%	1/4W
R811	1-249-409-11	CARBON	220	5%	1/4W
R812	1-249-409-11	CARBON	220	5%	1/4W
R813	1-249-418-11	CARBON	1.2K	5%	1/4W
R814	1-249-423-11	CARBON	3.3K	5%	1/4W
R815	1-249-423-11	CARBON	3.3K	5%	1/4W
R816	1-249-417-11	CARBON	1K	5%	1/4W
R817	1-249-417-11	CARBON	1K	5%	1/4W
R818	1-249-414-11	CARBON	560	5%	1/4W
R819	1-247-884-11	CARBON	1.3K	5%	1/4W
R820	1-247-840-00	CARBON	2.4K	5%	1/4W
R821	1-249-417-11	CARBON	1K	5%	1/4W
R822	1-249-417-11	CARBON	1K	5%	1/4W
R823	1-249-437-11	CARBON	47K	5%	1/4W
R824	1-249-437-11	CARBON	47K	5%	1/4W
R825	1-249-437-11	CARBON	47K	5%	1/4W
R826	1-249-437-11	CARBON	47K	5%	1/4W
R827	1-249-437-11	CARBON	47K	5%	1/4W
R828	1-249-437-11	CARBON	47K	5%	1/4W
R829	1-249-437-11	CARBON	47K	5%	1/4W
R830	1-249-437-11	CARBON	47K	5%	1/4W
R831	1-249-437-11	CARBON	47K	5%	1/4W

Ref.No.	Part No.	Description				
R832	1-249-437-11	CARBON	47K	5%	1/4W	
R833	1-249-437-11	CARBON	47K	5%	1/4W	
R834	1-249-430-11	CARBON	12K	5%	1/4W	
R835	1-247-862-11	CARBON	20K	5%	1/4W	
R836	1-249-431-11	CARBON	15K	5%	1/4W	
R837	1-249-425-11	CARBON	4.7K	5%	1/4W	
R838	1-249-437-11	CARBON	47K	5%	1/4W	
R839	1-249-405-11	CARBON	100	5%	1/4W	
R840	1-249-429-11	CARBON	10K	5%	1/4W	
R901	1-249-407-11	CARBON	150	5%	1/4W	
R902	1-249-407-11	CARBON	150	5%	1/4W	
R903	1-249-411-11	CARBON	330	5%	1/4W	
R904	1-249-407-11	CARBON	150	5%	1/4W	
R905	1-249-441-11	CARBON	100K	5%	1/4W	
R906	1-249-441-11	CARBON	100K	5%	1/4W	
R907	1-249-441-11	CARBON	100K	5%	1/4W	
R908	1-249-441-11	CARBON	100K	5%	1/4W	
R909	1-249-441-11	CARBON	100K	5%	1/4W	
R910	1-249-441-11	CARBON	100K	5%	1/4W	
R911	1-249-441-11	CARBON	100K	5%	1/4W	
R912	1-249-441-11	CARBON	100K	5%	1/4W	
R913	1-249-441-11	CARBON	100K	5%	1/4W	
R914	1-249-441-11	CARBON	100K	5%	1/4W	
R915	1-249-441-11	CARBON	100K	5%	1/4W	
R916	1-249-441-11	CARBON	100K	5%	1/4W	
R917	1-249-441-11	CARBON	100K	5%	1/4W	
R918	1-249-441-11	CARBON	100K	5%	1/4W	
R919	1-249-429-11	CARBON	10K	5%	1/4W	
R920	1-249-437-11	CARBON	47K	5%	1/4W	
R921	1-249-437-11	CARBON	47K	5%	1/4W	
R922	1-249-437-11	CARBON	47K	5%	1/4W	
R923	1-215-452-00	METAL	20K	1%	1/6W	
R924	1-215-452-00	METAL	20K	1%	1/6W	
R925	1-215-452-00	METAL	20K	1%	1/6W	
R926	1-215-452-00	METAL	20K	1%	1/6W	
R927	1-215-452-00	METAL	20K	1%	1/6W	
R928	1-215-452-00	METAL	20K	1%	1/6W	
R929	1-215-452-00	METAL	20K	1%	1/6W	
R930	1-215-445-00	METAL	10K	1%	1/6W	
R931	1-215-445-00	METAL	10K	1%	1/6W	
R932	1-215-445-00	METAL	10K	1%	1/6W	
R933	1-215-445-00	METAL	10K	1%	1/6W	
R934	1-215-445-00	METAL	10K	1%	1/6W	
R935	1-215-445-00	METAL	10K	1%	1/6W	
R936	1-215-460-00	METAL	43K	1%	1/6W	
R937	1-215-425-00	METAL	1.5K	1%	1/6W	

Ref.No.	Part No.	Description
RV101	1-228-993-00	RES, ADJ, CARBON 5K
RV151	1-228-995-00	RES, ADJ, CARBON 20K
RV152	1-228-995-00	RES, ADJ, CARBON 22K
RV201	1-228-993-00	RES, ADJ, CARBON 5K
RV251	1-228-995-00	RES, ADJ, CARBON 20K
RV252	1-228-995-00	RES, ADJ, CARBON 22K
RV511	1-238-097-11	RES, VAR, CARBON 20K/20K (REC LEVEL)
RV512	1-238-085-11	RES, VAR, CARBON 20K/20K (PHONES LEVEL)
RV513	1-238-373-11	RES, VAR, CARBON 5K (BIAS)
S511	1-571-741-11	SWITCH, ROTARY (DOLBY NR)
S512	1-571-742-11	SWITCH, ROTARY (MPX FILTER)
S701	1-570-103-21	SWITCH, PUSH (1 KEY)(POWER)
S801	1-571-742-11	SWITCH, ROTARY (MONITOR)
S901	1-554-596-21	SWITCH, KEY BOARD (■)
S902	1-554-596-21	SWITCH, KEY BOARD (▶▶)
S903	1-554-596-21	SWITCH, KEY BOARD (◀◀)
S904	1-554-596-21	SWITCH, KEY BOARD (▷)
S905	1-554-596-21	SWITCH, KEY BOARD (REC ●)
S906	1-554-596-21	SWITCH, KEY BOARD (PAUSE ■)
S907	1-554-596-21	SWITCH, KEY BOARD (REC MUTE ●)
S908	1-554-596-21	SWITCH, KEY BOARD (TAPE OPERATION)
S909	1-554-596-21	SWITCH, KEY BOARD (RESET)
S910	1-554-596-21	SWITCH, KEY BOARD (MEMORY)
S911	1-554-208-00	SWITCH, SLIDE (TIMER)

SPK101	1-235-186-00	ENCAPSULATED COMPONENT
SPK151	1-235-186-00	ENCAPSULATED COMPONENT
SPK201	1-235-186-00	ENCAPSULATED COMPONENT
SPK251	1-235-186-00	ENCAPSULATED COMPONENT



T151	1-433-344-11	TRANSFORMER, BIAS OSCILLATION
T251	1-433-344-11	TRANSFORMER, BIAS OSCILLATION
T511	1-433-343-11	TRANSFORMER, BIAS OSCILLATION
T701	1-449-484-11	TRANSFORMER, POWER

THP701 1-808-612-21 THERMISTOR, POSITIVE (1.85A)

X801 1-567-772-11 VIBRATOR, CERAMIC (4.19MHz)

ACCESSORY & PACKING MATERIAL

1-551-734-11	CORD, CONNECTION (RK-74A)
3-786-642-11	MANUAL, INSTRUCTION
*3-349-005-01	CUSHION
*3-577-909-11	INDIVIDUAL CARTON

Note: The components identified by mark  or dotted line with mark  are critical for safety. Replace only with part number specified.