

# TC-K666ES

518 ~~278~~  
AEP Model  
E Model



"Dolby" and the double-D symbol are the trade marks of Dolby Laboratories Licensing Corporation. Noise reduction system manufactured under license from Dolby Laboratories Licensing Corporation.

## STEREO CASSETTE DECK

### SPECIFICATIONS

Recording system 4-track 2-channel stereo  
Fast-forward and rewind time (with C-60 cassette)  
Approx. 60 sec. at normal speed  
Approx. 35 sec. at high speed  
Bias frequency 105 kHz  
Signal-to-noise ratio (NAB, at peak level)

Cassette	Dolby NR switch		
	OFF	B-TYPE ON	C-TYPE ON
TYPE IV (Sony METALLIC)	60 dB	67 dB	73 dB
TYPE III (Sony FeCr)	62 dB	69 dB	75 dB
TYPE II (Sony UCX)	59 dB	66 dB	72 dB
TYPE I (Sony BHF)	56 dB	63 dB	69 dB

Total harmonic distortion 0.8 % (with Sony METALLIC and FeCr cassettes)  
Frequency response DOLBY NR OFF  

- With TYPE IV cassette (Sony METALLIC)  
20 - 20,000 Hz  
25 - 19,000 Hz ( $\pm 3$  dB)  
25 - 14,000 Hz ( $\pm 3$  dB, 0 VU recording)  
25 - 19,000 Hz (DIN)
- With TYPE III cassette (Sony FeCr)  
20 - 20,000 Hz  
25 - 19,000 Hz ( $\pm 3$  dB)  
25 - 19,000 Hz (DIN)

### SAFETY-RELATED COMPONENT WARNING!

COMPONENTS IDENTIFIED BY SHADING AND MARKED WITH AN X ON THE SCHEMATIC DIAGRAMS AND IN THE PARTS LIST ARE CRITICAL TO SAFE OPERATION. REPLACE THESE COMPONENTS WITH SONY PARTS WHEN PART NUMBERS APPEAR AS SHOWN IN THIS MANUAL OR IN SUPPLEMENTS PUBLISHED BY SONY.

### ATTENTION AU COMPOSANT AYANT RAPPORT A LA SECURITE!

LES COMPOSANTS IDENTIFIES PAR UNE TRAME ET UNE X MARQUEE SUR LES DIAGRAMMES SCHEMATIQUES ET LA LISTE DES PIECES SONT CRITIQUES POUR LA SECURITE DE FONCTIONNEMENT. NE REMPLACEZ CES COMPOSANTS QUE PAR DES PIECES SONY DONT LES NUMEROS SONT DONNES DANS CE MANUEL OU DANS LES SUPPLEMENTS PUBLIES PAR SONY.

Tape Transport Mechanism Type	TCM-140D1
-------------------------------	-----------

# SONY

## SERVICE MANUAL

518 ~~278~~



# TC-K666ES

- With TYPE II cassette (Sony UCX)
    - 20 - 19,000 Hz
    - 25 - 18,000 Hz ( $\pm 3$  dB)
    - 25 - 18,000 Hz (DIN)
  - With TYPE I cassette (Sony BHF)
    - 20 - 19,000 Hz
    - 25 - 17,000 Hz (DIN)
- Wow and flutter 0.025 % WRMS (NAB)  
 $\pm 0.07$  % (DIN)
- Inputs Line inputs (phono jacks)  
 Sensitivity 77.5 mV (-20 dB)  
 Input impedance 50 k ohms
- Outputs Line outputs (phono jacks)  
 Output level 0.435 V (-5 dB) at a load impedance of 50 k ohms  
 Load impedance over 10 k ohms  
 Headphone output  
 Output level, variable from 0.3 to 0.003 mW at a load impedance of 8 ohms

**General**

- Power requirements AEP model: 220 V ac, 50/60 Hz  
 (240 V ac adjustable by authorized Sony personnel)  
 E model: 110, 120, 220 or 240 V ac adjustable, 50/60 Hz
- Power consumption 50 watts
- Dimensions Approx. 430 x 105 x 285 mm (w/h/d)  
 (17 x 4 $\frac{1}{4}$  x 11 $\frac{1}{4}$  inches)  
 including projecting parts and controls
- Weight Approx. 6.5 kg (14 lbs 6 oz)

**MODEL IDENTIFICATION**

— Specification Label —

AEP, E model

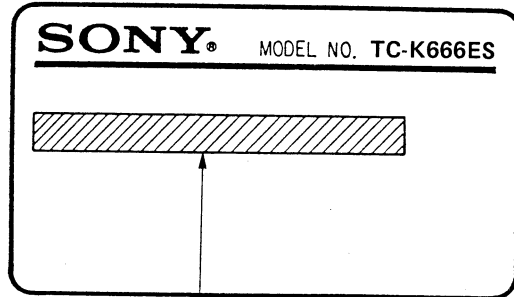

AEP model: AC: 220V ~ 50/60Hz 50W  
 E model: AC: 110, 120, 220, 240V ~ 50/60Hz 50W

G-AEP model

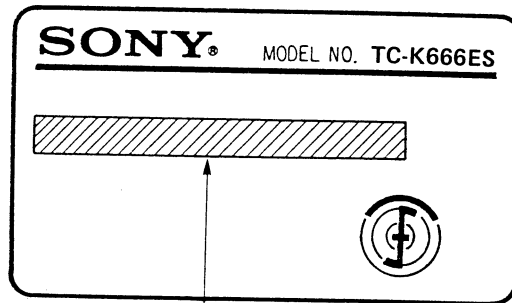

AC: 220V ~ 50/60Hz 50W

— Power Cord —

E1 model: 1-555-795-00

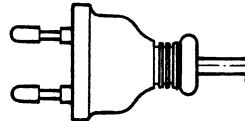

E2 model: 1-556-091-00



## SECTION 1

### OUTLINE

#### 1-1. GENERAL DESCRIPTION

##### FEATURES

###### Three-head system

Separate record and playback heads allow optimum gap settings and impedance ratings for distortion-free recording and greatly extended frequency response. For good tape-to-head contact, the heads are mounted in one block and each head is separately adjusted for precise azimuth alignment. The three-head system also enables you to monitor the recorded tape while actually recording.

###### Newly-developed LA (LaserAmorphous) head

The record and playback heads are made of a special amorphous magnetic alloy developed by Sony, and their cores are solidly welded by laser. This new highly-durable head provides a wider dynamic range and a more extended frequency response, especially in the high-frequency range. The head is designed to take full advantage of the potential of the metal tapes.

###### Closed-loop dual-capstan tape drive system

Two pairs of capstans and pinch rollers ensure uniform tape tension and stable tape-to-head contact. As a result, wow and flutter and modulation noise are greatly reduced.

###### Three motor drive

The three-motor drive system assures accurate and stable tape transport. The motors for the capstan and reel drives are linear torque BSL (brushless and slotless) motors with an extremely smooth torque. The speed of the capstan motor is regulated by a crystal oscillator. The shaft of the capstan motor drives the tape directly to eliminate any fluctuation in the tape speed which might be caused by belts or idlers.

###### Bias and recording level calibration

Bias current can be precisely adjusted to the optimum level for any tape on the market, assuring the flattest possible frequency response. Furthermore, the sensitivity of the tape can be compensated for, permitting optimum performance of the Dolby NR system.

###### Electronic back-tension control

The electronic back-tension control system detects the reel motor rotations and adjusts the torque to the motor properly at all times during tape transport in order to obtain even back-tension. Stable and optimum tape-to-head contact is ensured with this system.

###### Vibration-free diecast chassis

The chassis of the tape transport mechanism is diecast in aluminum and zinc alloy, which suppresses resonance of the chassis and greatly reduces the transmission of vibration to the tape.

###### High-quality amplifier section

The recording section and the playback section of the right and left channels are physically separated with the signal paths of the right and left channels parallel, using the symmetric Dolby NR ICs. The channel circuits themselves are well separated by a busbar to eliminate interference.

###### Useful functions

- The automatic monitor system automatically selects the source sound when recording, or the recorded sound when the tape is played back.
- The cueing function facilitates locating the very beginning of the selection while the recorded sound is being heard in rewind or fast-forward mode.
- The dual-speed rewind and fast-forward functions allows you to rewind and advance the tape more rapidly than by the normal rewind and fast-forward speed.
- A digital linear counter indicates the elapsed recording or playback time in minutes and seconds, and also indicates the remaining recording time with a minus sign.
- The pre-end winker system gives warning that the tape is nearing the end during recording, in which case the digits displayed on the tape counter flash on and off.
- The FL-display peak program meters follow the transient peaks of the music and maintain the peak readings for about 4 seconds.

##### OPERATING VOLTAGE

Before connecting the unit to the power source, check that the operating voltage of your unit is the same as the local power line voltage.

The AEP model operates on 220V ac (or 240V ac adjustable by authorized Sony personnel).

The E model operates on either 110, 120, 220 or 240V ac. The voltage selector is located on the rear panel. If the selector must be reset, **disconnect the ac power cord** and turn the selector with a coin so that the arrow on the selector points to the appropriate voltage.

## FUNCTION OF CONTROLS

The numbers in the photo are keyed to the following explanations.

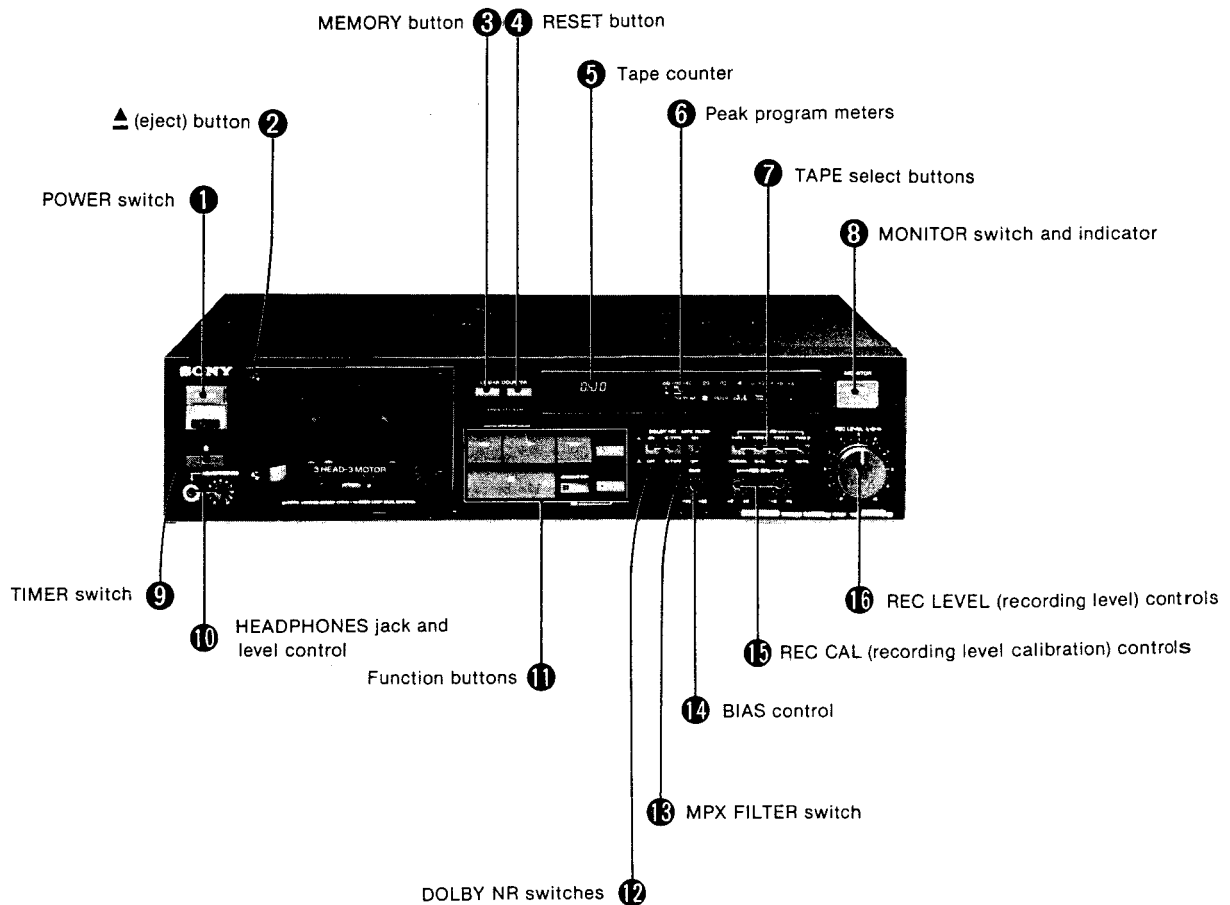

### 1 POWER switch

Depress this switch to turn on the power. The lamp in the cassette holder, the display of the peak program meters and the tape counter will light up. The indicator lamp of the PAUSE button will blink for about 4 seconds, indicating that the function buttons are inoperative during this period.

Press this switch again to turn the power off.

### 2 ▲ (eject) button

Press this button to open the cassette holder.

### 3 MEMORY button

Press to rewind the tape to the "0.00" point on the tape counter. The word "MEMORY" is displayed below the tape counter. Pressing the ► button together with the ◀◀ button automatically starts playback from "0.00."

When you do not use the memory function, press this button again. The word "MEMORY" will disappear.

### 4 RESET button

Press this button to reset the tape counter to "0.00."

### 5 Tape counter

This counter indicates the tape running time.

See "Using the digital linear counter" on page 12.

### 6 Peak program meters

With the SOURCE indicator illuminated, the meters show the peak input level of each channel, and with the TAPE indicator illuminated the meters show recorded levels. They follow the transient peaks of high-level inputs that are too brief to be followed by conventional VU meters so that the optimum recording level can be accurately set. The highest input of each channel is held about 4 seconds on the scale, except when a higher peak occurs before 4 seconds have passed, in which case that peak is immediately indicated.

### 7 TAPE select buttons

Depress one of the TAPE select buttons according to the type of tape to be used. When the appropriate button is depressed, the optimum equalization and bias current settings are obtained for recording, and the optimum equalization setting is obtained for playback.

### 8 MONITOR switch and indicator

This cassette deck's automatic monitor system automatically selects the source sound when the ● REC button is pressed to start recording, and the "SOURCE" indicator is illuminated on the MONITOR switch. When the ► button is pressed to start playback, the recorded sound will be selected automatically and the "TAPE" indicator will be illuminated. During recording you can change the monitor sound manually by pressing the MONITOR switch.



## 9 TIMER switch

You can set the unit to record or play back at a predetermined time by connecting any commercially available timer. To record, set this switch to REC. To play back, set it to PLAY. See "Timer-activated recording and playback" on page 14.

## 10 HEADPHONES jack and level control

Headphones may be inserted either to monitor the input signals to be recorded or to listen to a recording in the playback mode. Headphone volume is adjustable with the level control.

The HEADPHONES level control setting does not affect the peak program meters or the output level of the LINE OUT jacks at the rear.

## 11 Function buttons

It is possible to switch directly from one mode to another.

◀ (rewind) button: Press this button to rewind the tape. This button is also used for "Auto play" (page 13) and "Cueing" (page 10.)

■ (stop) button: To stop the tape, press this button. The tape will stop automatically when it is completely wound in either direction.

▶ (forward) button: Press this button to play the tape back. To record, press this button while holding the ● REC button down.

▶▶ (fast-forward) button: Press this button to advance the tape rapidly. This button is also used for "Cueing". See page 10.

● REC (record) button: Press this button together with the ▶ button to start recording.

⏸ PAUSE (pause) button: To pause for a moment during recording or playback, press this button. This button is also used to control more precisely the start of recording, to release the record muting mode and to initiate the cueing.

○ REC MUTE (record muting) button: Press this button to eliminate unwanted material and to insert a blank space during recording. See "Record muting" on page 13.

## 12 DOLBY NR switches

The left switch turns the Dolby NR\* (Noise Reduction) system on and off and the right switch selects either the B-type or C-type Dolby NR system.

To record with the Dolby NR process, depress the ON/OFF switch to the ON position and choose between B-TYPE (□) and C-TYPE (▢).

To record without the Dolby NR process, press the ON/OFF switch again to release it.

When playing back, set these switches to the same position used in recording.

For details about the Dolby NR system, see page 15.

\*"Dolby" and the double-D symbol are trade marks of the Dolby Laboratories Licensing Corporation. Noise reduction system manufactured under license from Dolby Laboratories Licensing Corporation.

## 13 MPX FILTER switch

Normally set this switch to OFF (□).

When recording FM stereo broadcasts with the Dolby NR system, set it to ON (▢) if the 19 kHz pilot signal and the 38 kHz subcarrier have not been adequately suppressed by the FM tuner or receiver. If the tuner or the receiver suppresses such signals adequately (most high-quality tuners and receivers will), you do not have to set this switch to ON.

## 14 BIAS control

When recording, turn this control to adjust the bias current precisely depending on the characteristics of the tape being used.

## 15 REC CAL (recording level calibration) controls

When recording, turn these controls to adjust the recording level depending on the sensitivity of the tape being used.

## 16 REC LEVEL (recording level) controls

These controls adjust the recording level. The knob nearest the panel is for the left channel and the other knob for the right channel. To adjust the level of the left or right channel only, turn the appropriate knob while holding the other knob.

## REMOTE control connector (on the rear panel)

Connect the optional RM-50 (wired) or RM-80 (wireless) remote control unit to operate the tape transport functions from a distance. Synchronized operation is also possible with selected Sony turntables, using the optional RM-65 synchro remote control unit. Read the instruction manual of your remote control unit before operating it.

## CONNECTIONS

### Notes

- Turn the amplifier off before making any connection.
- Be sure to insert the plugs firmly into the jacks. Loose connections may cause hum and noise.

- The red plug of the supplied connecting cord should be connected to the red jack (R: right channel) and the other plug to the white jack (L: left channel).

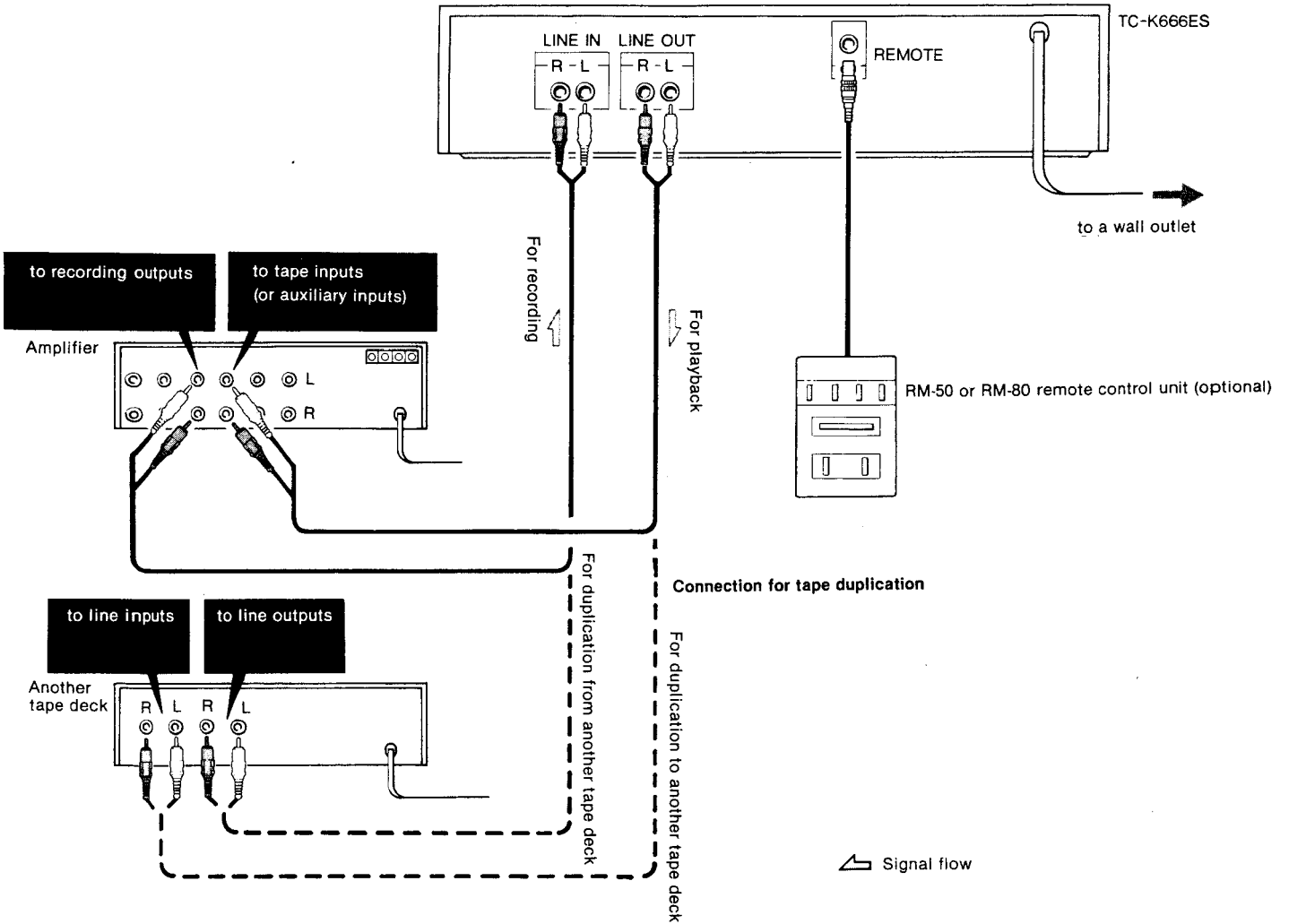

### Synchronized operation using the optional RM-65 synchro remote control unit

When this cassette deck is connected to a turntable equipped with a synchro remote control jack using the RM-65, the operation of the cassette deck and the turntable will be synchronized. For more details refer to the instruction manuals of the RM-65 and the turntable.

### Power cord

A white mark is visible on one lead of the power cord. This will help you drive the cassette deck and other components in the system "in phase" by aligning the ac power cord polarities with ac outlet polarities. In most cases, the marked plug of the cassette deck's power cord should be inserted into the negative potential of the ac outlet.

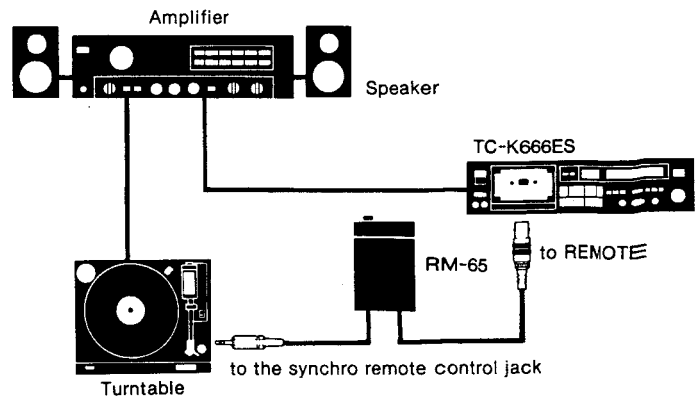

## RECORDING

### TO RECORD

The numbers in this diagram indicate the sequence to be followed.

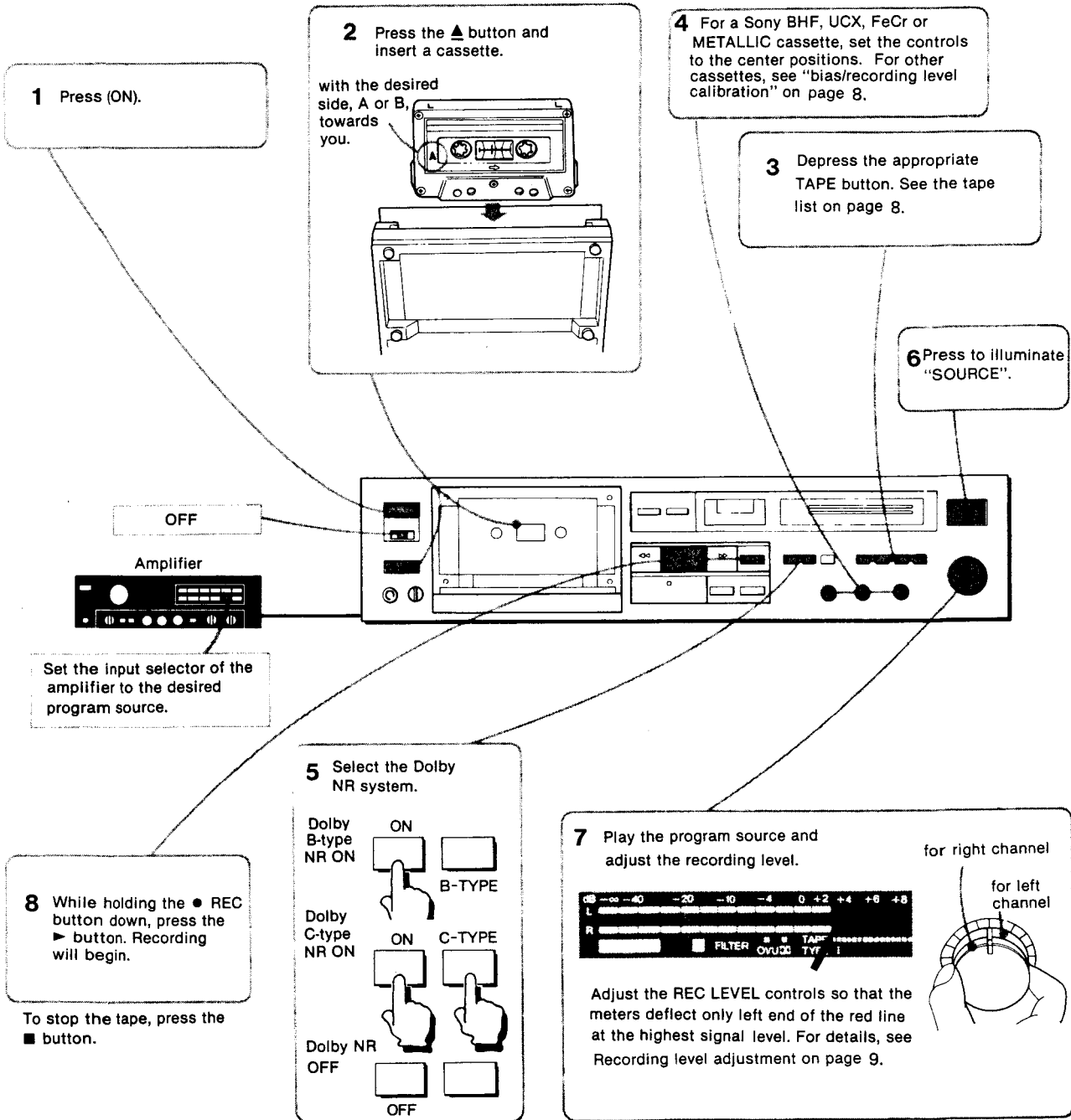

#### Note on the TIMER switch

If the power is turned on when this switch is set to the REC or PLAY position, recording or playback will start automatically after 4 seconds. To avoid accidental erasure of previously-recorded material, check that the TIMER switch is set to OFF before turning on the POWER switch.

To cancel the recording or playback, press the **■** button within 4 seconds after the power is turned on.

#### Pre-end winker

When the tape approaches the end during recording, the digits on the counter will blink, warning that the tape is about to run out (We call this function the pre-end winker.) The blinking will begin 2 to 3 minutes before the end of the tape for a C-46 or C-60 cassette, and 3 to 5 minutes before the end of the tape for a C-90 cassette. Note that the pre-end winker may not function if a cassette with very thick hub is being used.

## RECOMMENDED SETTINGS FOR THE TAPE SELECT BUTTONS

Press the appropriate TAPE select button referring to the recommended settings listed below.

While the settings are optimum for Sony cassettes, you may want to change them when using cassettes produced by other manufacturers.

### Tape list

Tapes (C-60 and C-90)		Type of tape
<b>SONY:</b> AHF, BHF, BASF: LH-X, Professional I MAXELL: UD, UD-XL I, XL I-S SCOTCH: MASTER I	AGFA: SUPER FERRO DYNAMIC FUJI: FX-I PHILIPS: SUPER FERRO-I TDK: AD	TYPE I (NORMAL)
<b>SONY:</b> UCX-S, UCX BASF: Professional II MAXELL: UD-XLII, XLII-S SCOTCH: MASTER II	AGFA: STEREO CHROM FUJI: FX-II PHILIPS: CHROMIUM TDK: SA, SA-X	TYPE II (CrO <sub>2</sub> )
<b>SONY:</b> FeCr BASF: Professional III SCOTCH: MASTER III	AGFA: CARAT PHILIPS: FERRO CHROMIUM	TYPE III (Fe-Cr)
<b>SONY:</b> METALLIC	Other metal tapes	TYPE IV (METAL)

## BIAS/RECORDING LEVEL CALIBRATION

There are many different cassettes on the market and their characteristics vary. The proper equalization characteristics and bias current will be obtained when the appropriate TAPE button is pressed. With this cassette deck you can adjust the recording characteristics much more precisely using the bias and recording level calibrating function.

### Bias calibration

Too high a bias level gives a rolled-off high-frequency response, and too little bias reduces the signal-to-noise ratio and increases distortion.

To adjust the bias current to the level which gives the best possible frequency response, proceed as follows.

- 1 Insert the cassette to be recorded.
- 2 Press the appropriate TAPE button according to the type of tape.
- 3 Play the program source.  
For easier bias calibration, choose a monotone as a source program, such as the calibration tone generated by the oscillator built in the FM/AM tuner, if provided.
- 4 Press the ● REC and ► buttons to start recording.
- 5 While recording, press the MONITOR switch to TAPE and adjust the BIAS control so that the recorded sound heard is as identical as possible to the source sound.

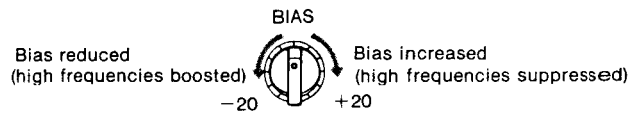

### Recording level calibration

The Dolby NR function is most effective when the recording level and the playback level are the same. After completing the bias calibration, calibrate the recording level as follows. Tape sensitivity will be compensated for automatically.

- 6 Adjust the REC CAL controls so that the peak program meters deflect to the same point and the recorded sound heard is as close as possible, to the sound heard when the MONITOR switch is pressed to SOURCE.

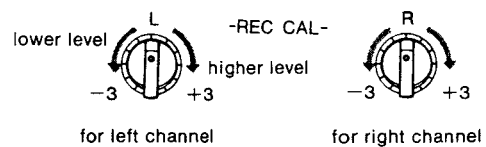

The bias current is now adjusted to the optimum level and the tape sensitivity is compensated for.

In order to erase the recorded program, rewind the tape and start recording.

## RECORDING LEVEL ADJUSTMENT

Adjust the recording level while monitoring on the peak program meters the input level of the program source to be recorded. If the recording level setting is too high, the recording will be distorted, and if the setting is too low, the recording will be noisy. The recording level should be set as high as possible while still avoiding distortion. This level will depend on the type of tape being used. When the TAPE button is pressed, the range above the saturation level of the selected type of tape is indicated by the red line. Generally speaking, adjust the recording level by making sure that the meters deflect only to the left end of the red line at the highest signal level.

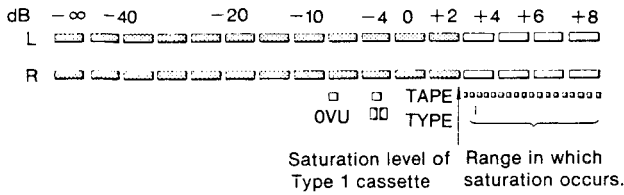

Since the saturation level of any tape is lower in the higher frequencies than in the lower frequencies, the recording level may still be too high if adjusted in this way if the program to be recorded contains many high frequency signals. Consideration has to be given to the program source to be recorded as well as to the characteristics of the cassette to be used, since each cassette, even cassettes using the same type of tape, may have different characteristics. The following table will provide you with a starting point in setting the recording level of various kinds of programs when using Sony cassettes.

Type of tape	Sony cassettes	Low and mid freq. range programs (vocal, etc.)	Mid and high freq. range programs (piano, guitar, etc.)
I	BHF	+ 3 dB	+ 1 dB
	AHF	+ 4 dB	+ 2 dB
II	UCX	+ 3 dB	+ 2 dB
III	FeCr	+ 5 dB	+ 1 dB
IV	METALLIC	+ 6 dB	+ 6 dB

## RECORD MONITORING

As this cassette deck has separate record and playback heads, you can easily compare the source and the recorded sounds in the recording mode by using the MONITOR switch. You can check the recording level and whether there is any contamination on the heads that is affecting the recording.

This cassette deck's **automatic monitor system** automatically selects the source sound (SOURCE) when the ● REC button is pressed to start recording. To monitor the recorded sounds in the recording mode, press the MONITOR switch or the ● REC button to illuminate the "TAPE" indicator.

● If the connected amplifier has a tape monitor selector, source/tape comparison is possible with the amplifier monitor selector. In this case, set the cassette deck MONITOR switch to TAPE.

## MONITOR switch setting and signal flow

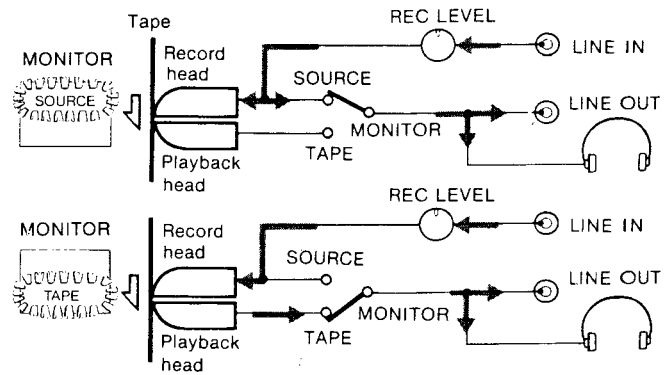

## TO RECORD MATERIAL ONTO A SPECIFIC PORTION OF TAPE

When you want to re-record a specific portion of tape or to insert new material between two points on a tape you will find it handy to be able to change directly from the playback to the record mode by pressing the ● REC button while holding the ► button down.

## PLAYBACK

The numbers in this diagram indicate the sequence to be followed.

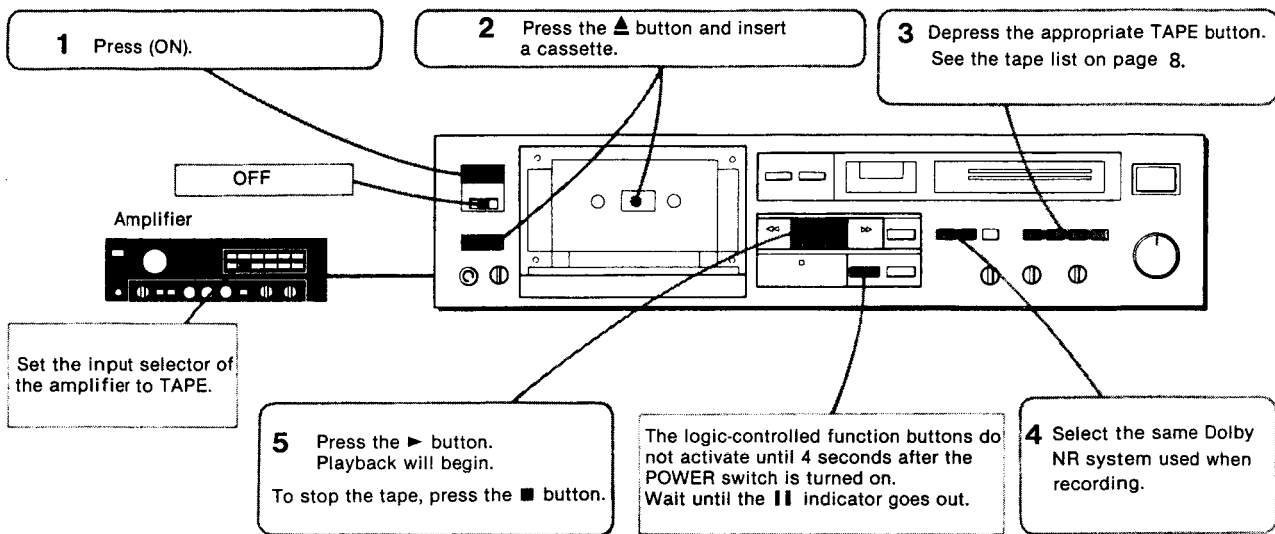

## CUEING

You can accurately locate the beginning of the selection using this cueing function.

- 1 Rewind the tape or move it "fast-forward" to a position approximate to the beginning of the selection you wish to play.
- 2 While holding the **||** PAUSE button down, press the **◀** or **▶** button. (cueing standby mode)

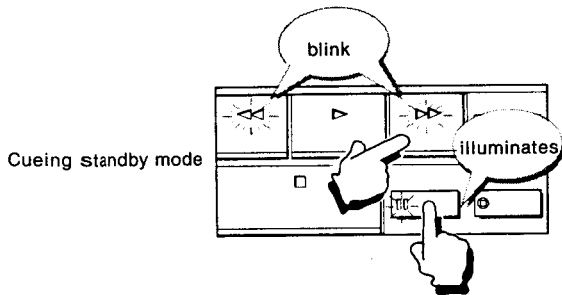

- 3 Press the **◀** and **▶** buttons alternately and locate the exact beginning of the selection while carefully listening to the chattering sound. When the button is released, the deck will revert to the cueing standby mode.

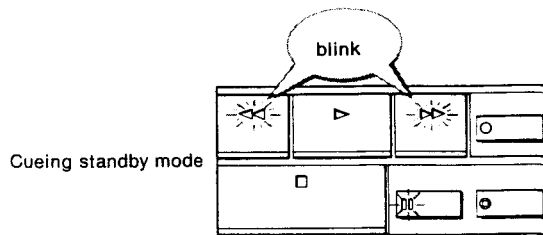

- 4 To play back, press the **▶** button.

If the **◀** or **▶** button is kept depressed, the tape will rewind or move forward slowly, while a chattering sound will be heard, caused by the recorded section.

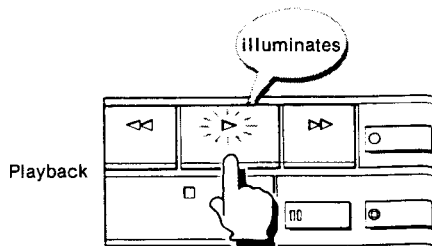
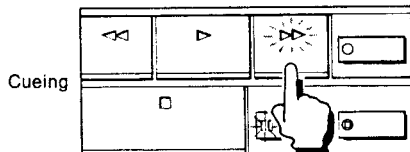

## DUAL-SPEED REWIND AND FAST-FORWARD

With this cassette deck, you can rewind the tape or run it "fast-forward" at two different speeds, that is, at normal speed also and at a speed which is twice that of normal speed.

### Note

High-speed rewind and fast-forward actions require only half the time as for normal-speed rewind and fast-forward actions, when the tape is wound from one end to the other. However, near the end of the tape, it will slow down to avoid causing excessive jerk to the tape when it stops. Note that the high-speed rewind or fast-forward action cannot reduce the time effectively when it starts from the middle of the tape.

**Do not use the high-speed rewind or fast-forward function with the following types of tapes:**

- Those with a playback time of less than 5 minutes on one side. (The tape might break when it is wound to the end by using the high-speed rewind or fast-forward action.)
- Those which make excessive noise when using the normal rewind or fast-forward action.
- Those with very thick hubs.

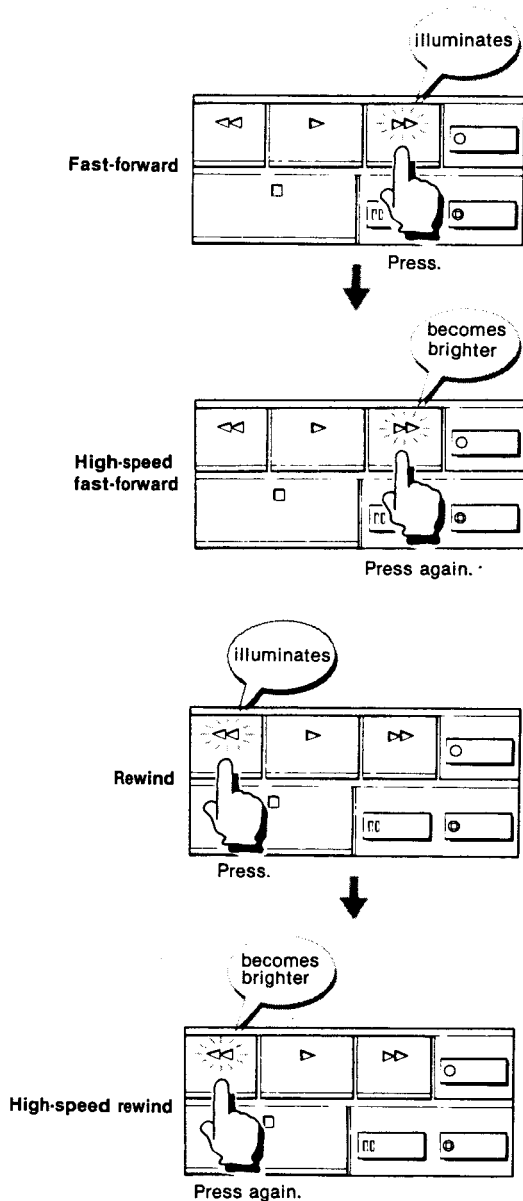

If the ◀◀ or ▶▶ button is pressed again during high-speed rewinding or fast-forward movement, the rewind or fast-forward speed will revert to normal speed.

## USING THE DIGITAL LINEAR COUNTER

The first two digits of this tape counter show the approximate recording or playback time in minutes, and the last two digits show the seconds.

### TO INDEX THE WHOLE TAPE



Before recording or playback, set the counter to "0.00" by pressing the RESET button.

As the tape runs, the figures of the counter change. Note the numbers and the program being recorded or played back. Any point of the tape can thus be readily located later by reference to these numbers.

### TO VERIFY THE AMOUNT OF RECORDING TIME POSSIBLE ON ONE SIDE OF A CASSETTE

At the beginning of the tape, set the counter to "0.00" and run the tape "fast-forward" to the end. The digits on the counter will show the approximate available recording time.



30 min. 15 sec.

### TO DETERMINE THE REMAINING RECORDING TIME

Stop the tape at the point at which you wish to begin recording later. Set the counter to "0.00" and run the tape "fast-forward" to the end. The digits on the counter will show the approximate recording time still remaining.



2 min. 30 sec. remain.

● To rewind the tape to "0.00" and start recording automatically, use the "memory stop" function described on page 13.

### TO MONITOR THE REMAINING RECORDING TIME WHILE RECORDING—Using the minus display

This counter shows the recording or playback time from the "0.00" point with a minus sign in front of the digits when the tape is rewound beyond "0.00."

Before recording, move the tape "fast-forward" to the end, then set the counter to "0.00," and rewind the tape to the beginning. The digits on the counter will show the approximate recording time on one side of the cassette.

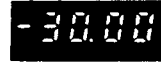

30 min. available

The digits will change from -30.00 to -29.59, -29.58 ... as the recording goes on, and you can monitor the remaining recording time at any point on the tape.

#### Note

Do not turn off the power while measuring the time because the numbers will return to "0.00" when the power is turned on again.

#### The accuracy of the counter

This counter is not actually a digital clock, so that the displayed figures are not exactly equal to the actual elapsed time. The accuracy will vary depending on the type of tape being used. This counter has been designed using C-60 cassettes as the standard. Make sure that the displayed time is greater than the time required, when using a C-46 cassette.

#### Difference between the counter indication and actual running time on one side of a cassette

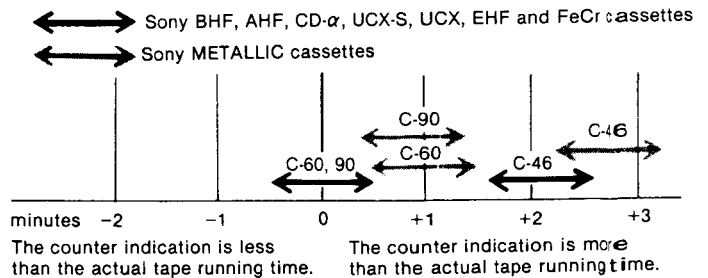



## AUTO PLAY AND MEMORY PLAY/STOP

### Auto play

To start the playback from the beginning

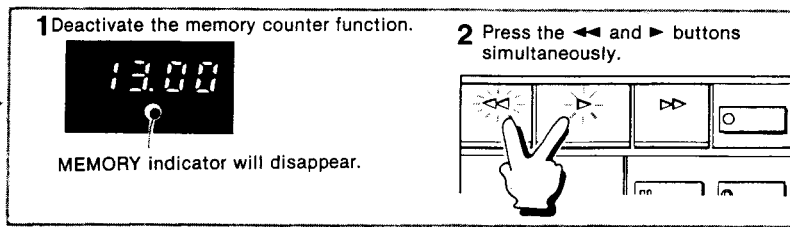

After the tape is rewound completely, the rewind mode will be disengaged and the tape will automatically replay.

### Memory play

To start the playback from a particular point after rewinding

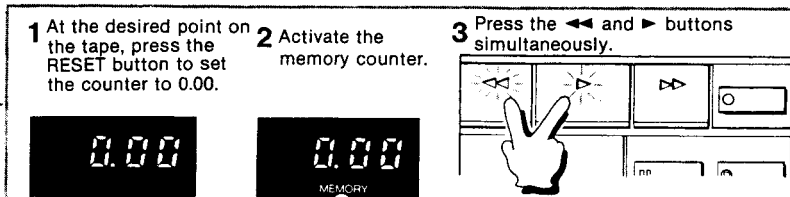

The tape replays automatically after rewinding to the "0.00" point.

### Memory stop

To stop the tape at the desired point when rewinding

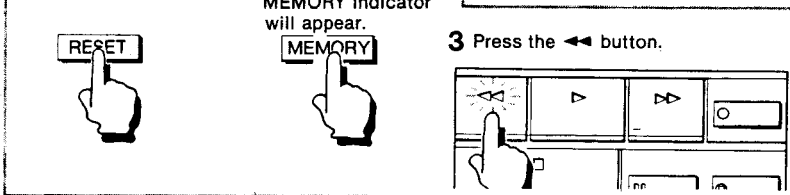

The tape stops automatically when it is rewound to the "0.00" point.

### Why does the tape stop around -0.01?

In order to avoid any chance of cutting off the starting point.

### How can the tape be rewound further than 0.00?

Press the ◀ button again.

## RECORD MUTING

By pressing the ● REC MUTE button during recording, four seconds interspacing is provided automatically, eliminating unwanted program material such as broadcasting commercials. While the record muting is operating, the incoming signal is not recorded on the tape but it continues to register on the meters and feed to the monitor so that you know exactly what is going on.

1 Press the ● REC MUTE button when the segment you do not want to record begins. The || indicator will blink, and the tape path will pause automatically after four seconds.

2 When you want to resume recording, press the || PAUSE button.

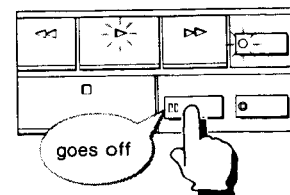

A blank is made while the tape continues to run.

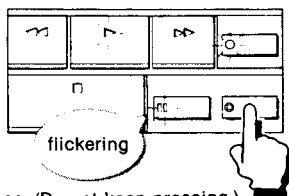

### To insert a blank less than four seconds long

Press the ● REC MUTE button to mute recording. Press the || PAUSE button when you want to resume recording.

### To insert a blank over four seconds long

Hold down the ● REC MUTE button for as long as you want the blank segment on the tape to be. After four seconds, the || indicator will blink more rapidly. When you release the ● REC MUTE button, the tape deck will be in the pause mode. When you want to resume recording, press the || PAUSE button to release the pause mode.

The tape pauses after 4 seconds.

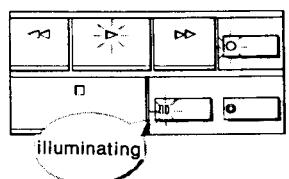

## ERASING

When the tape deck functions in recording mode, the erase head automatically erases any previously recorded material.

To erase without recording :

- 1 Make sure that the safety tab of the cassette is in place, or that the tab slot is covered with plastic tape.
- 2 Set the REC LEVEL controls fully to "0." (Disconnecting all inputs will result in a more complete erasure.)
- 3 Press the appropriate TAPE select button according to the type of tape to be erased. (The TYPE IV button assures good erasing for any type of tape.)
- 4 While holding the ● REC button down, press the ► button.

## TIMER-ACTIVATED RECORDING AND PLAYBACK

By connecting any commercially available timer to the tape deck, the deck can be set to play back or record automatically at any desired time. As timers work in different ways, be sure to read the timer's instruction manual carefully.

### To record a broadcast using a timer

- 1 Connect the tape deck, amplifier, tuner and timer. Set the timer so that power is supplied to the connected equipment.
- 2 Turn on the amplifier and tuner and tune in the station which will broadcast the program you want to record.
- 3 Set the tape deck's TIMER switch to OFF.
- 4 Insert a cassette. Make sure that the tab is intact or that plastic tape covers the tab slot.
- 5 Turn on the tape deck and adjust the recording level.
- 6 Set the timer for the desired time. (At this point power to the connected equipment will be cut off.)
- 7 Set the tape deck's TIMER switch to REC.  
The tape deck is now ready to start recording at the time set on the timer.

### To play back using a timer

The connections between equipment are the same as for recording using a timer.

- 1 Set the tape deck's TIMER switch to OFF.
- 2 Turn on the amplifier and set the appropriate switches for playback.
- 3 Turn on the tape deck and insert the recorded cassette.
- 4 Set the timer for the desired time. (At this point power to the connected equipment will be cut off.)
- 5 Set the tape deck's TIMER switch to PLAY. The tape deck is now ready to start playback at the time set on the timer.

### Notes

- The tape deck's TIMER switch will function properly only if the tape deck is turned on **after** the switch is set to REC or PLAY. If you want to change the setting of the switch, turn the power off first.
- After a timer-activated recording or playback, be sure to set the TIMER switch to OFF. If the switch is still set to REC, recording will start automatically when the deck is turned on the next time. In this case you can cancel the recording by pressing the ■ button within 4 seconds after the power is turned on.

**DOLBY NR (NOISE REDUCTION) SYSTEM**

There have been until recently just two types of Dolby NR system: the A-type for professional use, and the B-type, a simplified version of the A-type, employed by most consumer-grade cassette decks. Now, a third type of Dolby NR system is available, the C-type. The C-type system reduces tape noise much more effectively than the B-type system.

**The basis of the Dolby NR system**

During recording, low-level high-frequency signals, which tend to be obscured by tape hiss, are boosted so that they are substantially higher in level than any tape noise. When these signals are played back, the level is lowered to the original input level, while simultaneously the level of any tape noise is reduced to the same extent.

The Dolby B-type NR system thus reduces tape noise by 10 dB at 5 kHz. The C-type system reduces noise by 20 dB at 5 kHz. The Dolby C-type NR system also begins to take effect at frequencies lower than the B-type system.

**Anti-saturation network**

Normally, recording tape will saturate more easily at the higher frequencies. The Dolby C-type NR system incorporates a high frequency anti-saturation network. During recording, the anti-saturation network automatically reduces high-level high-frequency signals. When these signals are played back, the level is automatically boosted to the original input level. At 10 kHz, the tendency of the tape to saturate is reduced by 4 dB by the use of this network.

**Playback of Dolby NR encoded tapes**

For the best sound, lowest distortion, and most effective noise reduction, it is essential that a tape recorded using either the B-type or the C-type Dolby NR system be played back using the same system that was used during the recording process. We recommend that you label the cassettes you record as being either non-Dolby NR, Dolby B NR, or Dolby C NR.

**Fig. 1 Encoding characteristics**

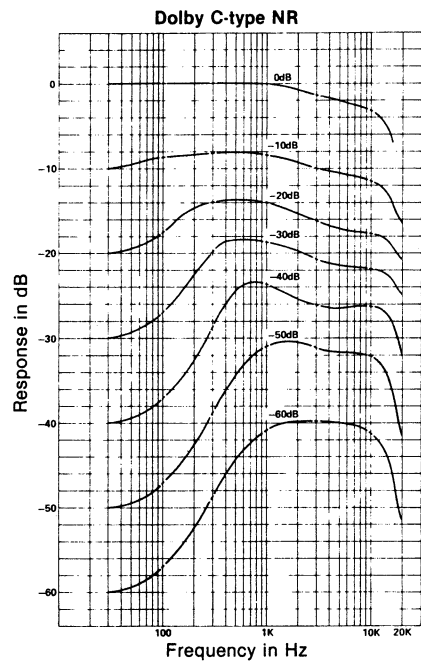
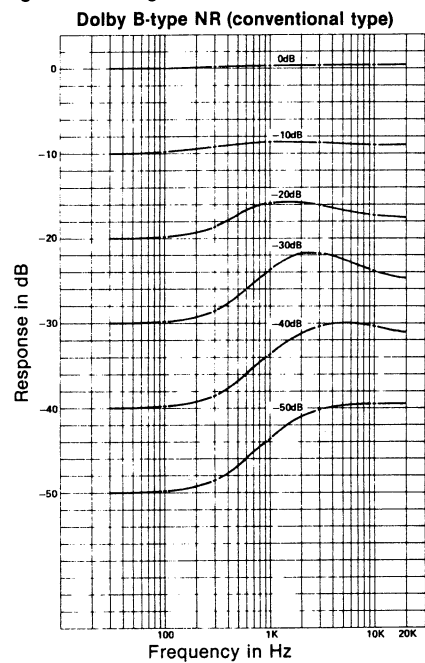

**Fig. 2 Noise improvement**

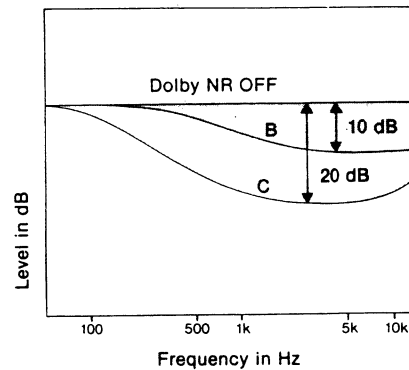

**Fig. 3 Saturation level improvement**

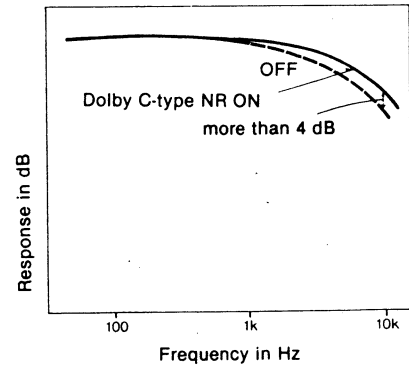

**1-2. BLOCK DIAGRAM**

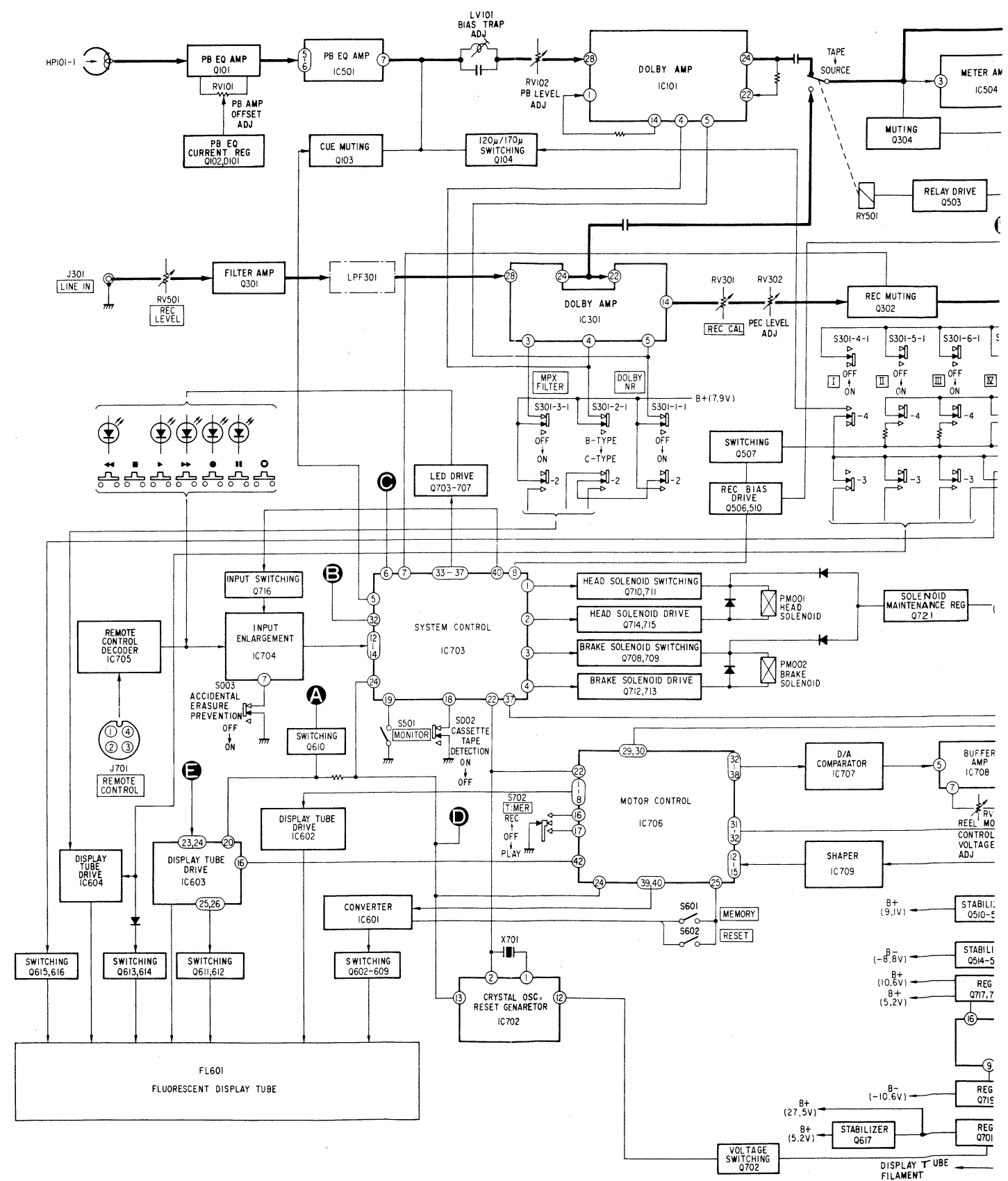



Note: Follow the disassembly procedure in the numerical order given.

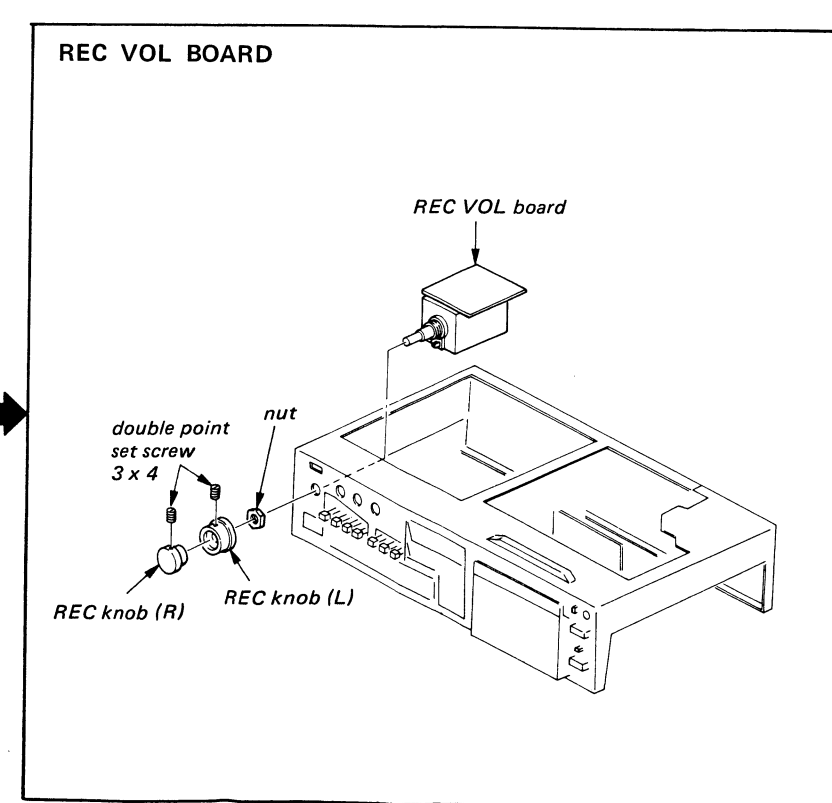
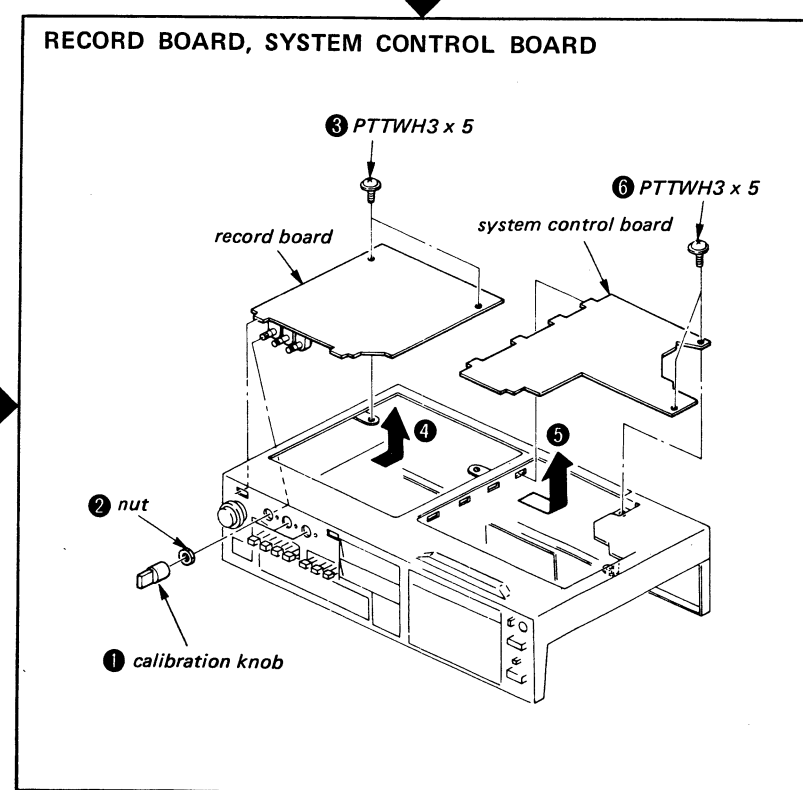
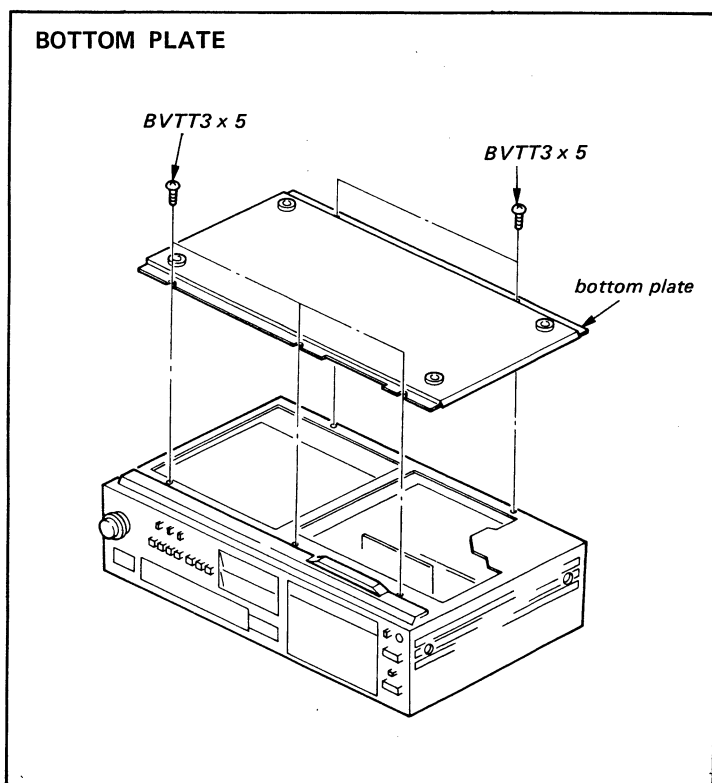
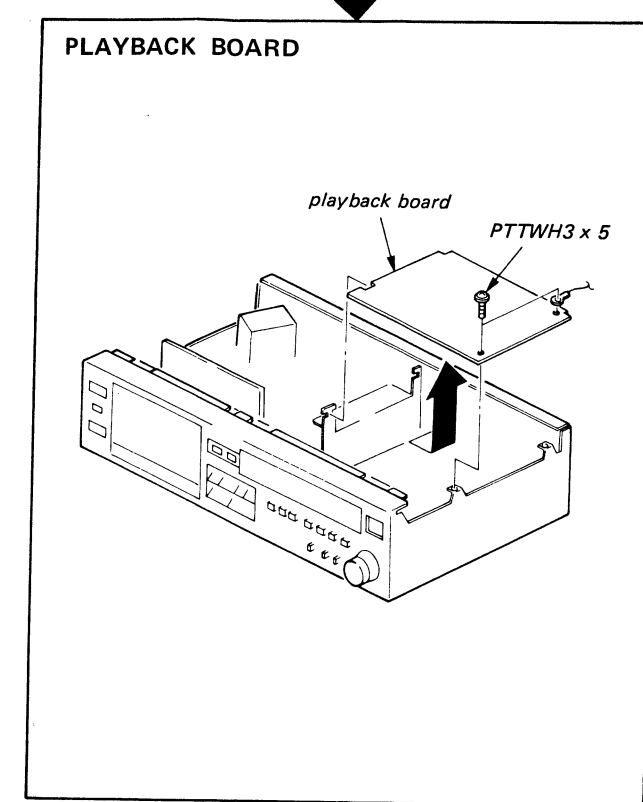
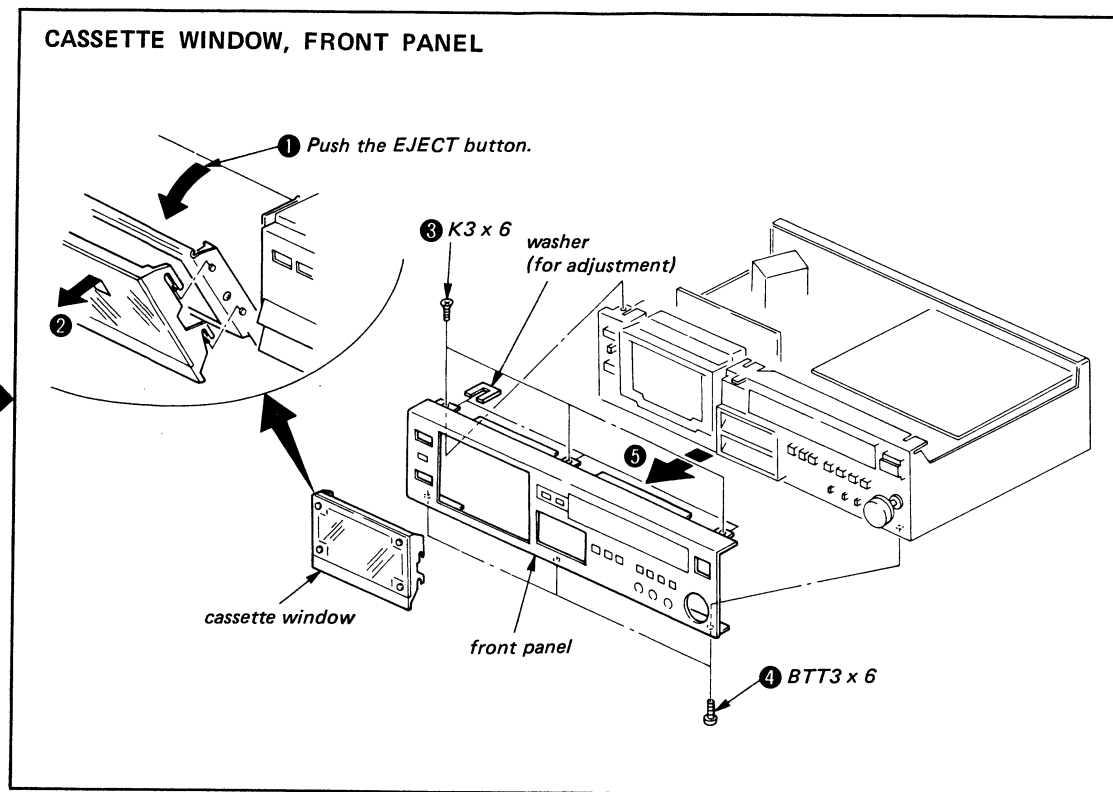
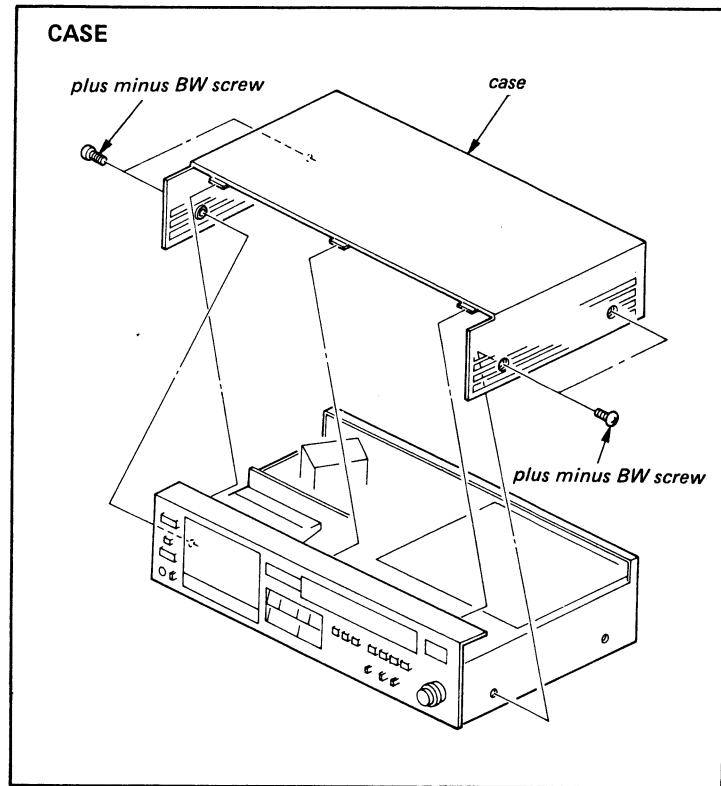

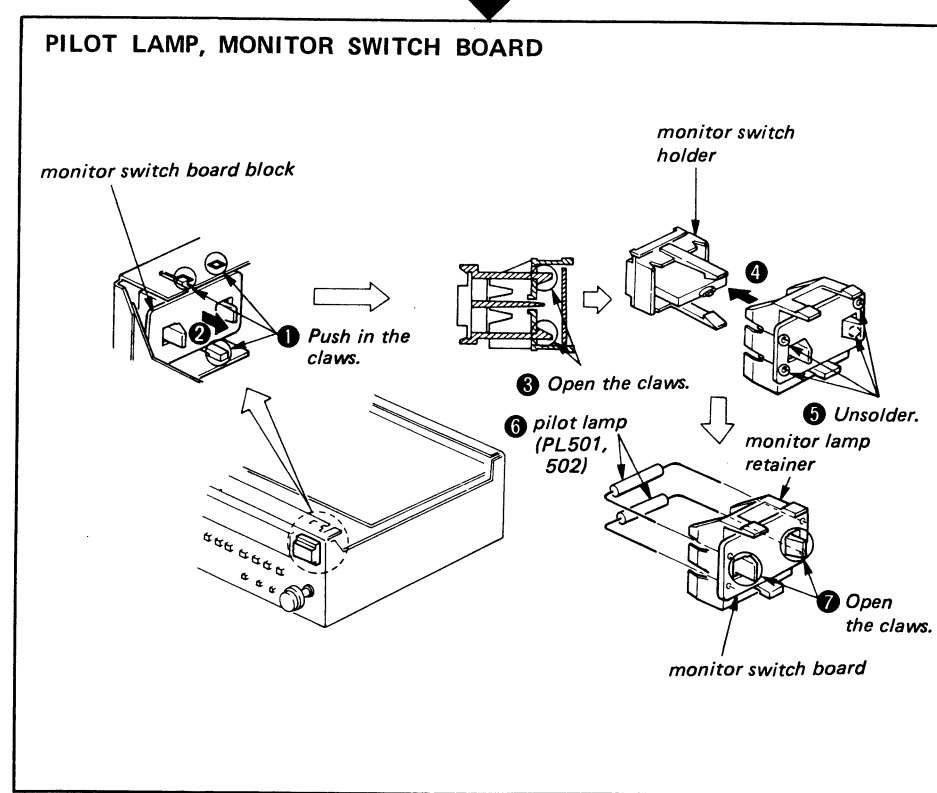
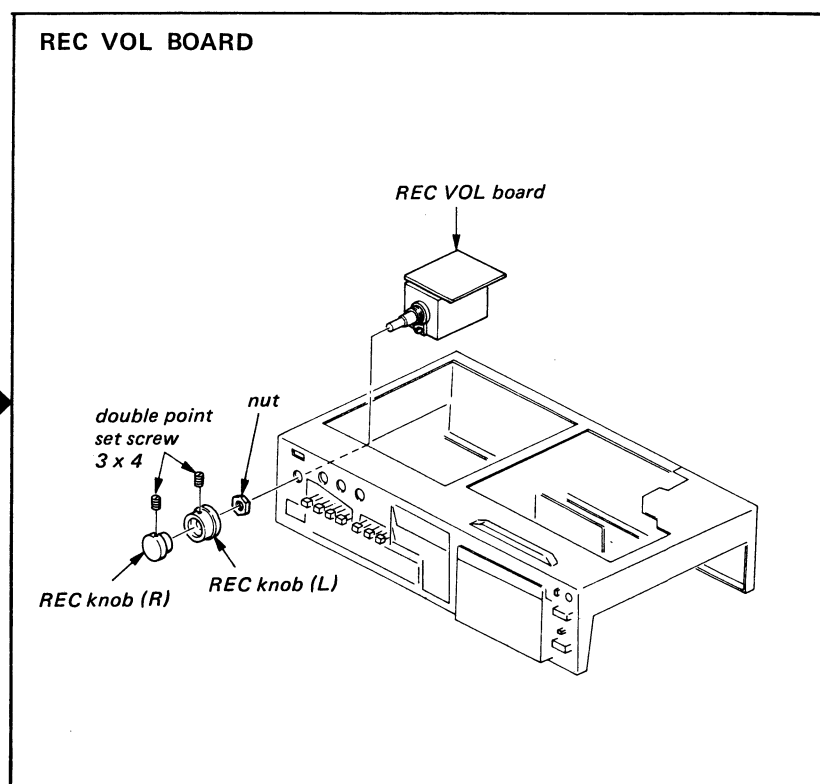
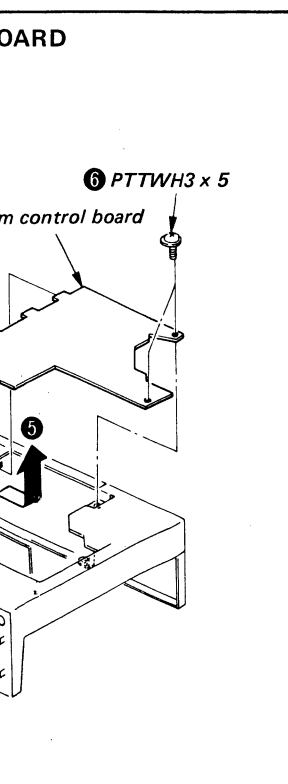
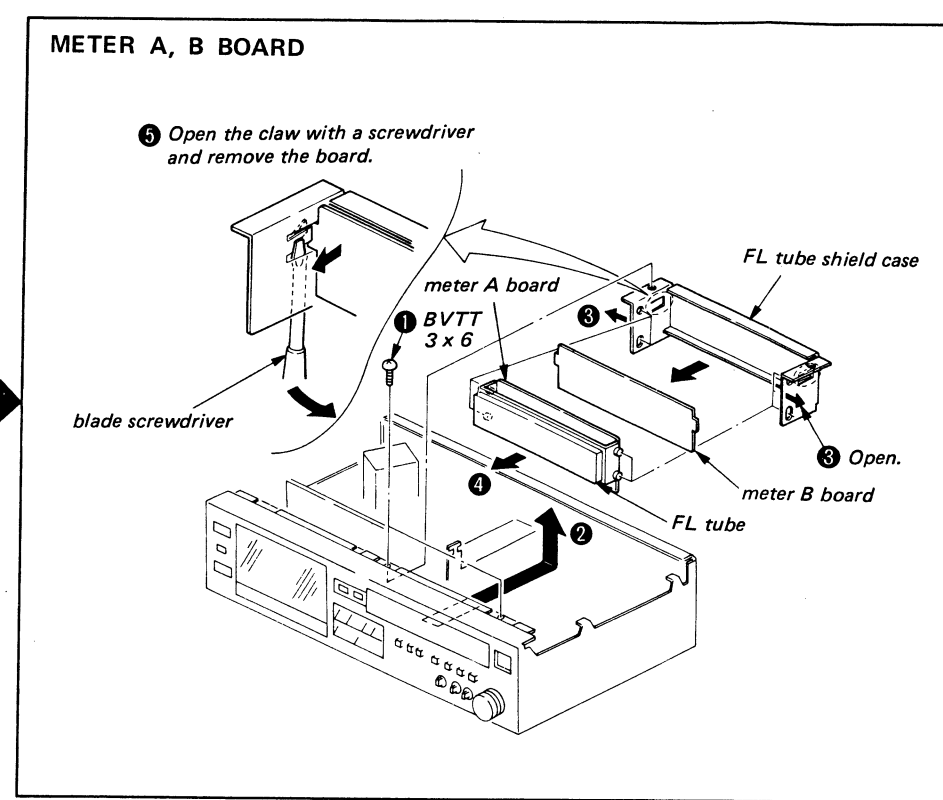
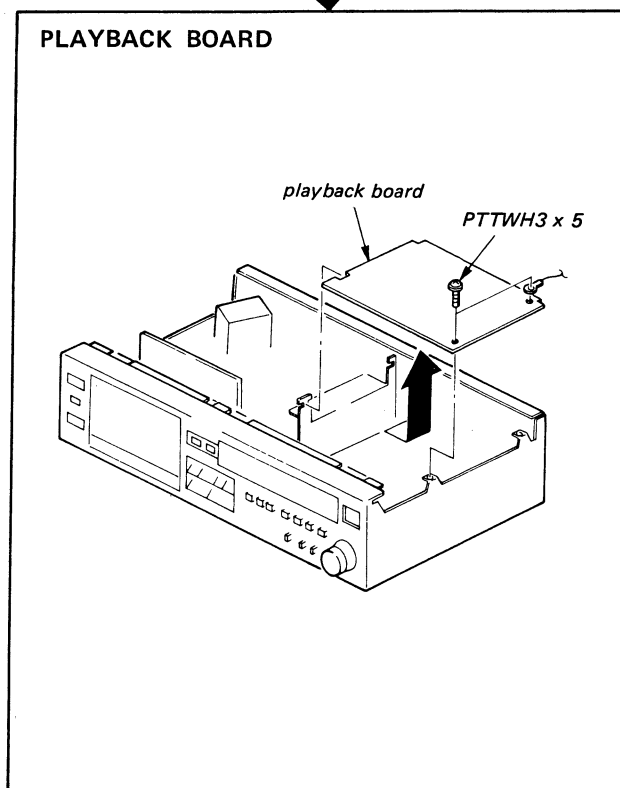
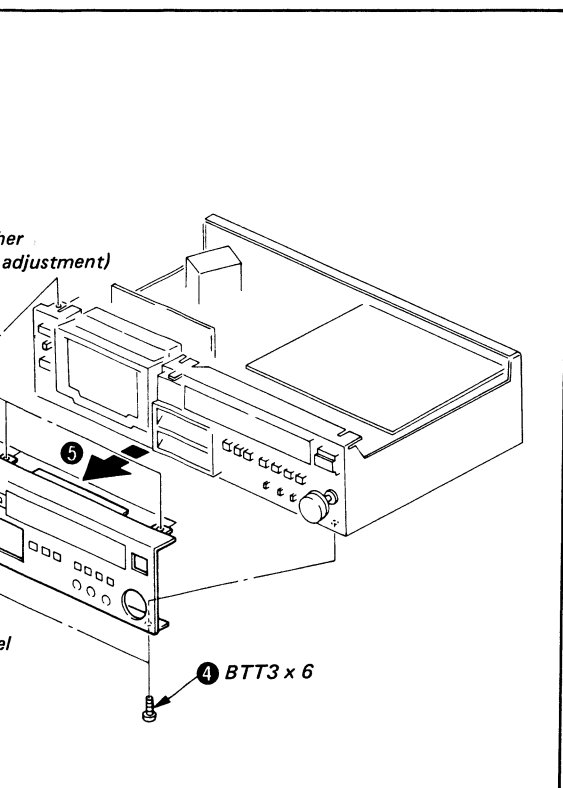

TAPE SELECT BOARD

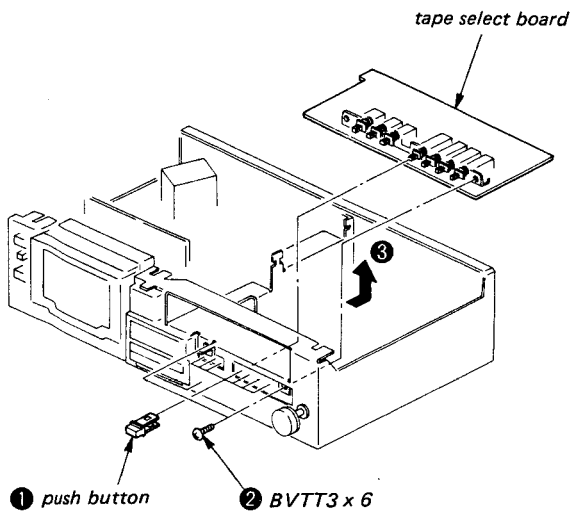

HEADPHONE BOARD

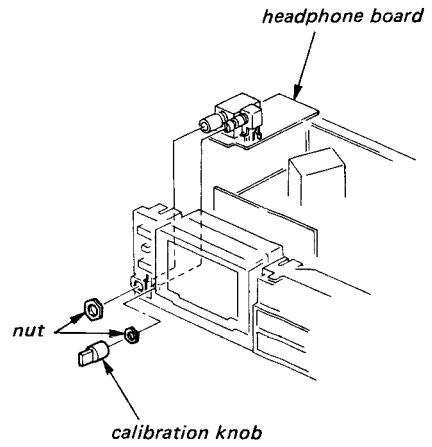

COUNTER RESET BOARD, FUNCTION SWITCH BOARD

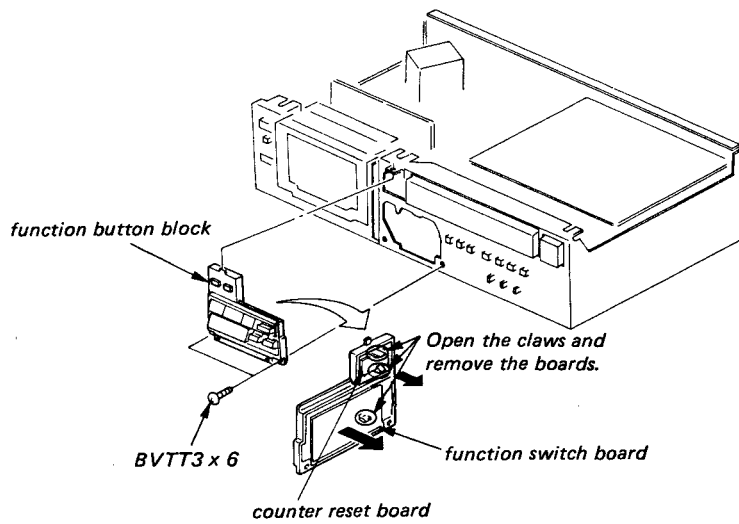

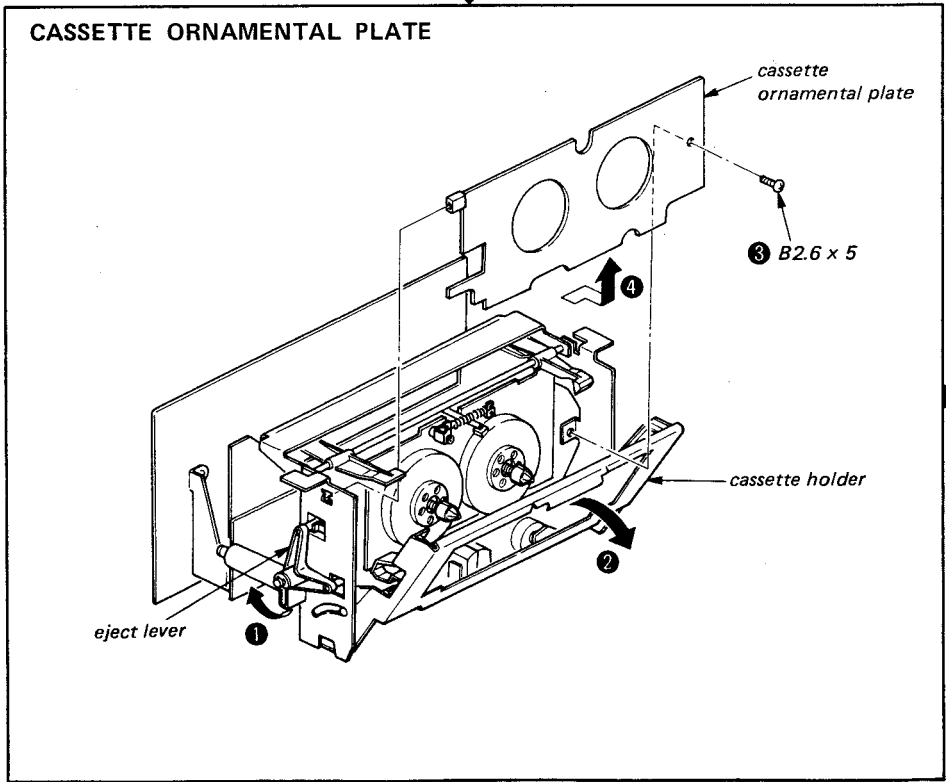
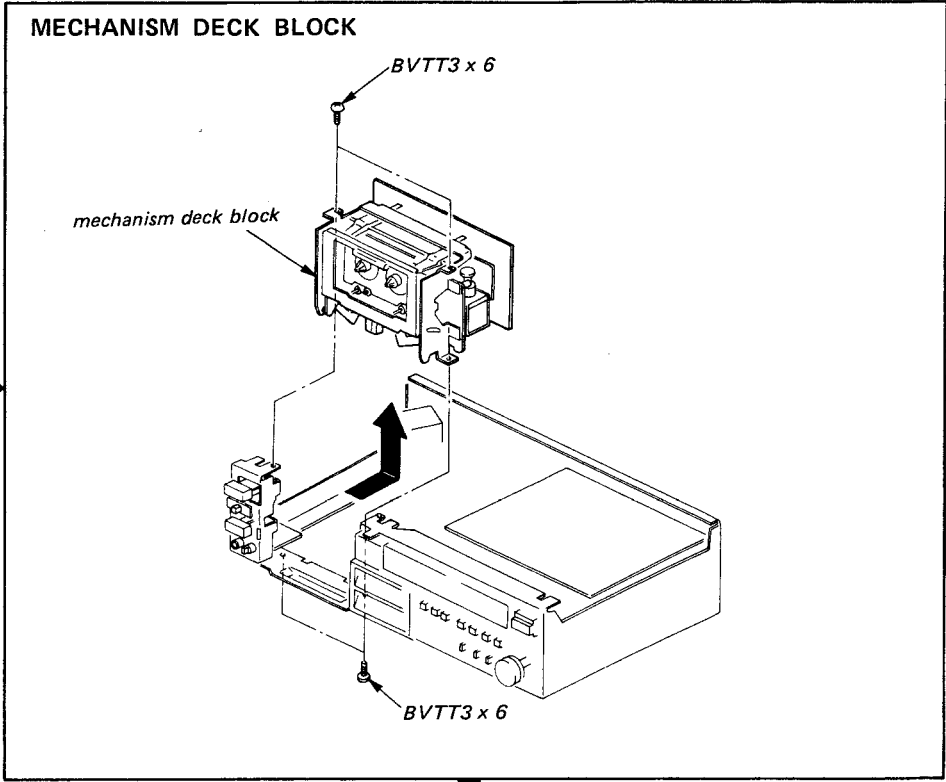



SERVO BOARD, SWITCH BOARD, CAPSTAN MOTOR BOARD

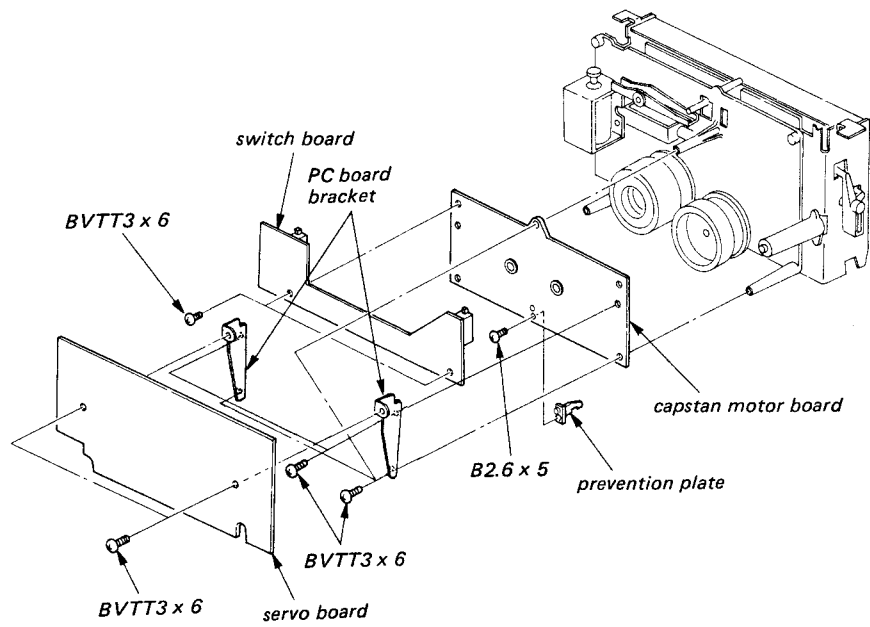

FLYWHEEL (S), (T)

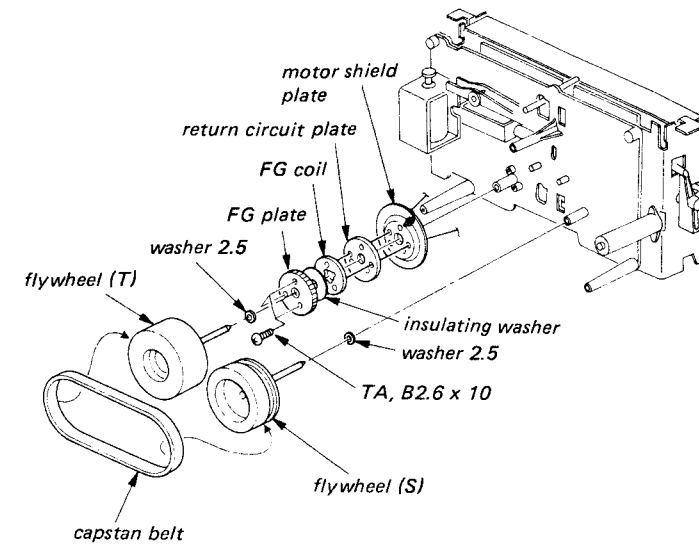

BRAKE SOLENOID

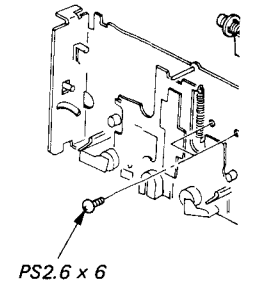

CASSETTE HOLDER BLOCK, RELEASE PLATE

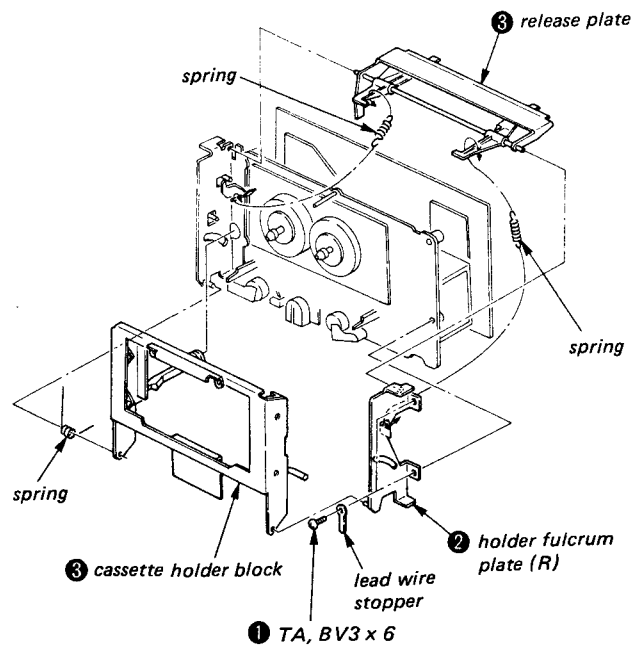

REEL MOTOR BOARD, HEAD SOLENOID

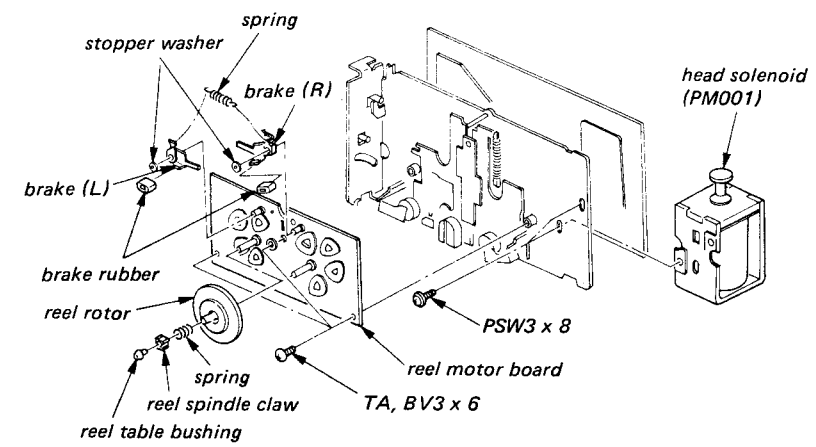

• Notes on Head Solenoid Replacement

If the mounting position is not correct, the amount of head movement changes, so the two mounting screws should be in the same position as before removal when mounting the head solenoid. (Make marks next to the two screws before removing.) After mounting, apply screw lock.

CASSETTE HOLDER, PILOT

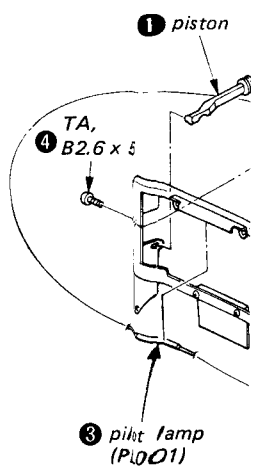

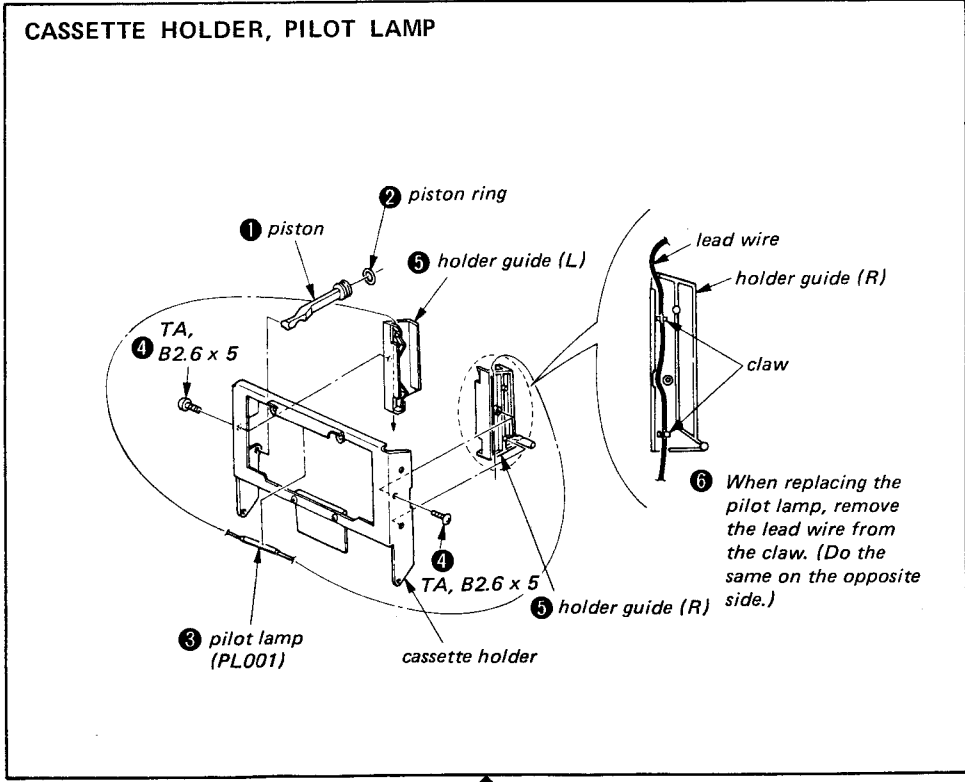
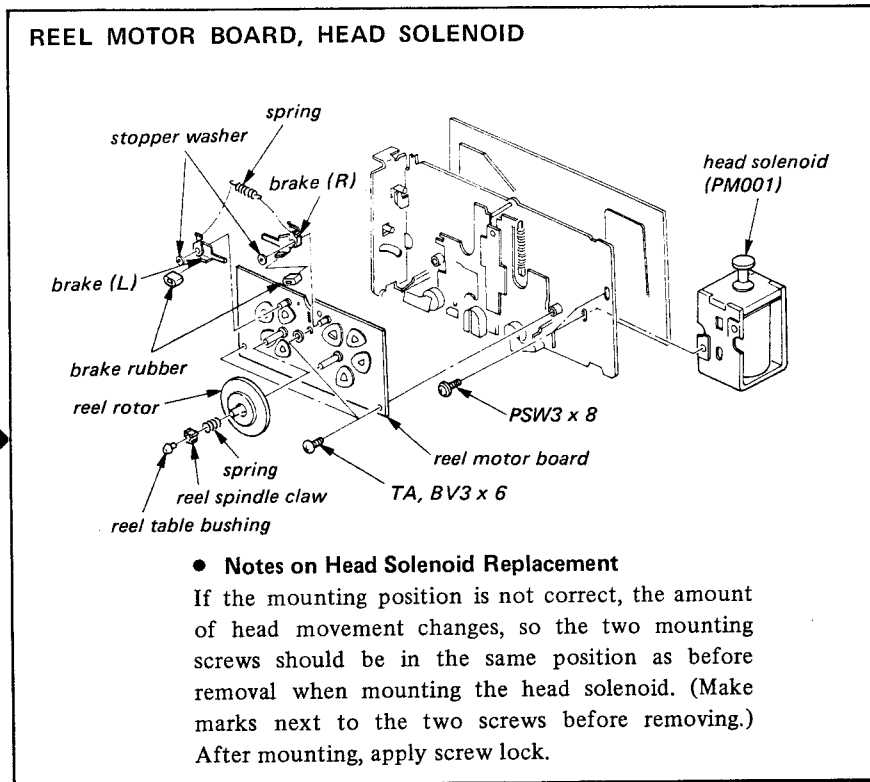
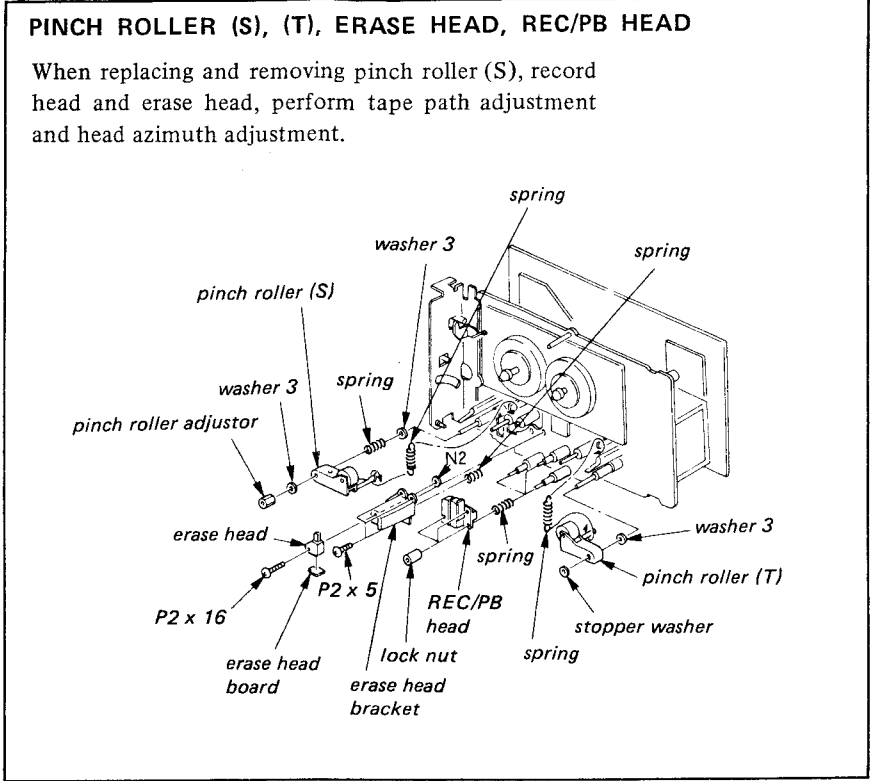
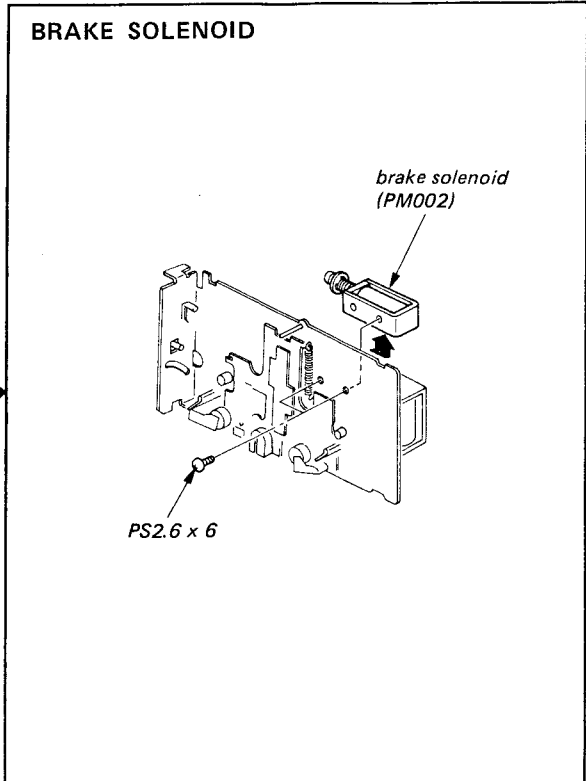
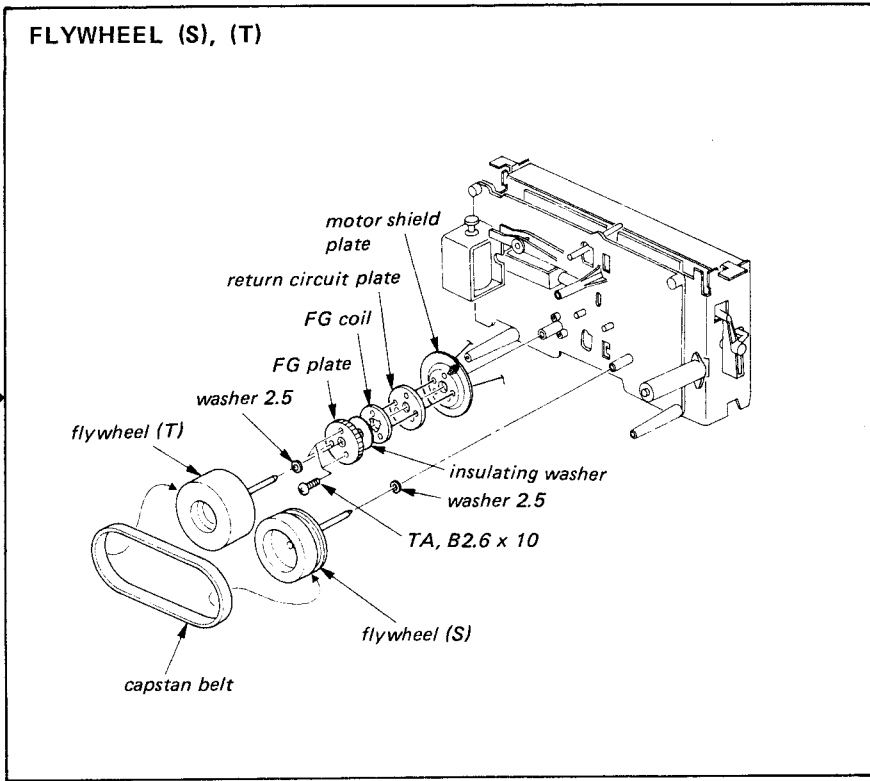

3-1. MECHANICAL ADJUSTMENTS

PRECAUTION

1. Clean the following parts with a denatured-alcohol-moistened swab:
2. Demagnetize the record/playback head with a head demagnetizer. (Do not bring the head demagnetizer close to the erase head.)
3. Do not use a magnetized screwdriver for the adjustments.
4. After the adjustments, apply suitable locking compound to the parts adjusted.
5. The adjustments should be performed with the rated power supply voltage unless otherwise noted.

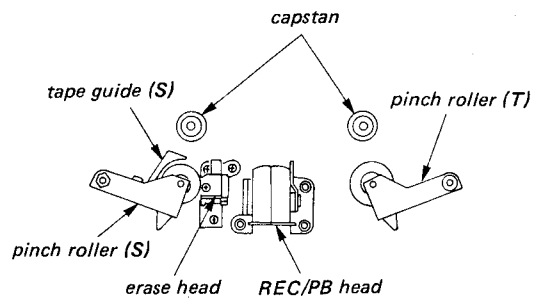

Pinch Roller Compression Measurement

— Playback mode —

1. Hang the spring scale on the pinch roller.
2. Pull the spring scale out parallel to the mechanical chassis edge and separate the pinch roller from the capstan. Then return it slowly and read the spring scale value when the pinch roller begins to rotate.
3. If necessary, replace the spring.

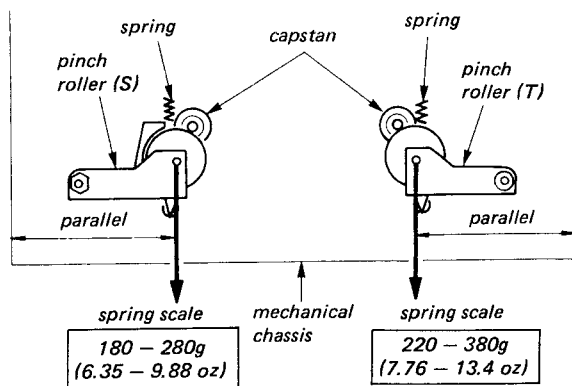

Flywheel Thrust Adjustment

1. T-side flywheel thrust adjustment.  
Turn the thrust screw until the clearance between the flywheel (T) and capstan motor board is 3.2 - 3.4mm.
2. S-side flywheel thrust adjustment  
Lightly tighten the thrust screw clockwise until there is no play on the flywheel (S). Then loosen the thrust screw 1/2 - 3/4 turns from that position.

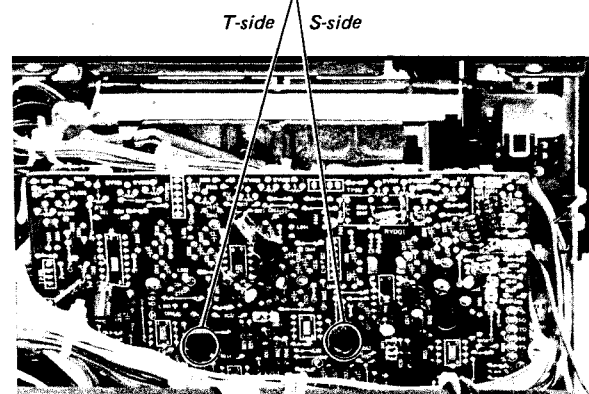
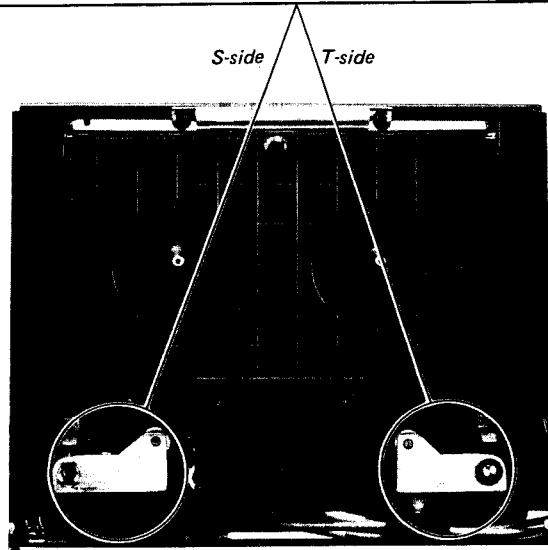
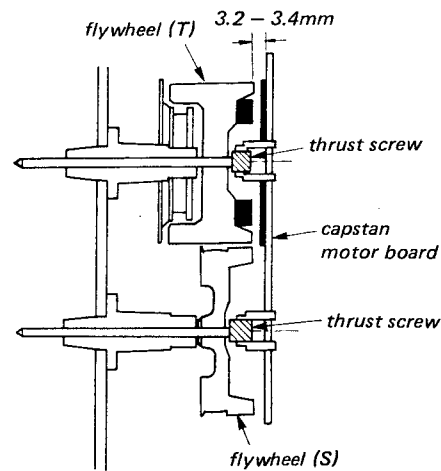

Perform this adjustment after replacing pinch roller (S), record/playback head or erase head.

Tape Path Adjustment

Insert a mirror cassette (CQ-009C) and put into play mode.

— After replacing pinch roller (S) —

1. Confirm that there is no tape curl at the tape guides.
2. If there is tape curl, loosen the hexagonal socket set screw inside the pinch roller adjustor which secures the pinch roller (S) (with tape guide), and adjust the pinch roller adjustor until tape curl disappears. After adjusting, tighten the screw without turning the pinch roller adjustor.

— After replacing record/playback head —

1. Confirm that there is no tape curl at the record/playback head.
2. If there is tape curl, loosen the hexagonal socket set screws inside lock nuts (A), (B), (C), and adjust the lock nuts until tape curl disappears. After adjusting, tighten the hexagonal socket set screws without turning the lock nuts.
3. Set back tension at 0 and confirm that there is no tape wave at sections (1), (2), (3) and (4).
4. If there is wave, do zenith adjustment with lock nuts (A), (B) and (C).

— After replacing erase head —

1. Confirm that the erase head is in the position shown in Fig. a.
2. If it is not, adjust screws (D), (E) and (F).
3. Set back tension at 0 and confirm that there is no tape wave at sections (1), (2), (3) and (4).
4. If there is wave, do zenith adjustment with screws (D), (E) and (F).
5. After adjusting, lock screws (D), (E) and (F).

— Reflection on Mirror Cassette —

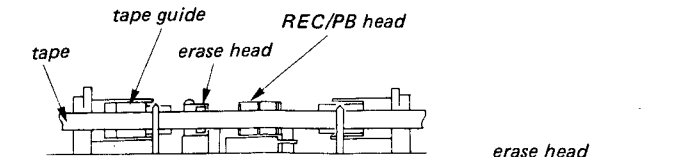

— As seen from front of set —

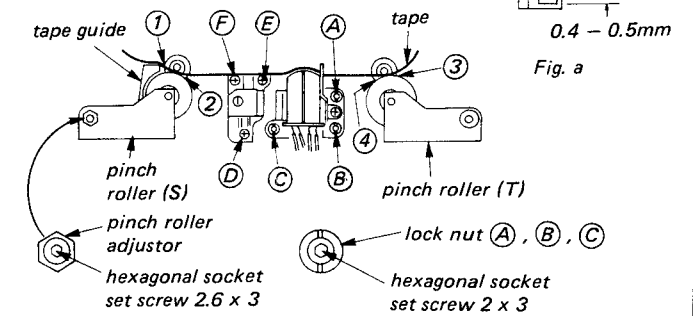

Soft Eject Adjustment

1. Insert a cassette tape and close the cassette window.
2. Turn the adjustment screw so that the opening time of the cassette window is 0.5 - 1.5 sec. when the eject button is pressed.

Adjustment Screw	Opening Time
clockwise	slower
counterclockwise	faster

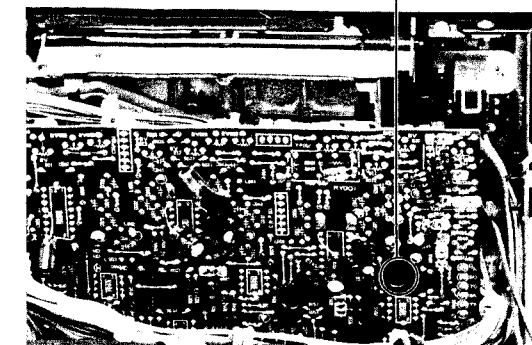

3-2. E

1. The to the
2. The give
3. The L-C

- Set tap

- Swi unl
- RE
- BIA
- RE
- DO
- TA
- MP
- TIM
- Sta
- Del
- inp
- obt

- Stand:
- sou
- inp

- Stand:
- loa
- out

Perform this adjustment after replacing pinch roller (S), record/playback head or erase head.

**Tape Path Adjustment**

Insert a mirror cassette (CQ-009C) and put into play mode.

— After replacing pinch roller (S) —

1. Confirm that there is no tape curl at the tape guides.
2. If there is tape curl, loosen the hexagonal socket set screw inside the pinch roller adjustor which secures the pinch roller (S) (with tape guide), and adjust the pinch roller adjustor until tape curl disappears. After adjusting, tighten the screw without turning the pinch roller adjustor.

— After replacing record/playback head —

1. Confirm that there is no tape curl at the record/playback head.
2. If there is tape curl, loosen the hexagonal socket set screws inside lock nuts (A), (B), (C), and adjust the lock nuts until tape curl disappears. After adjusting, tighten the hexagonal socket set screws without turning the lock nuts.
3. Set back tension at 0 and confirm that there is no tape wave at sections (1), (2), (3) and (4).
4. If there is wave, do zenith adjustment with lock nuts (A), (B) and (C).

— After replacing erase head —

1. Confirm that the erase head is in the position shown in Fig. a.
2. If it is not, adjust screws (D), (E) and (F).
3. Set back tension at 0 and confirm that there is no tape wave at sections (1), (2), (3) and (4).
4. If there is wave, do zenith adjustment with screws (D), (E) and (F).
5. After adjusting, lock screws (D), (E) and (F).

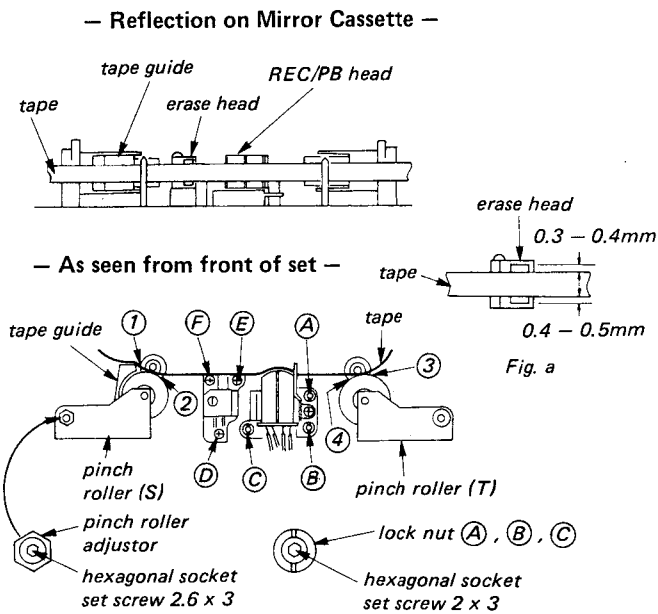

**Soft Eject Adjustment**

1. Insert a cassette tape and close the cassette window.
2. Turn the adjustment screw so that the opening time of the cassette window is 0.5 – 1.5 sec. when the eject button is pressed.

Adjustment Screw	Opening Time
clockwise	slower
counterclockwise	faster

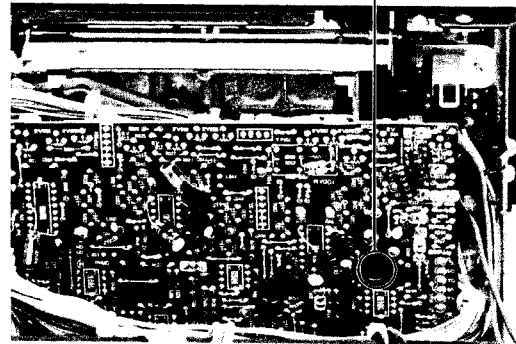

**3-2. ELECTRICAL ADJUSTMENTS**

1. The adjustments in the following sections are to be performed with the mechanism deck in the set.

2. The adjustment should be performed in the order given in this service manual.

3. The adjustments should be performed for both L-CH and R-CH.

- Set the TAPE select switches according to the tape as follows.

tape	TAPE select switch
CS-15	TYPE I
CS-26	TYPE II
CS-30	TYPE III
CS-42	TYPE IV

- Switches and controls should be set as follows unless otherwise specified.

- REC LEVEL (L/R) control : mechanical mid
- BIAS control : mechanical mid
- REC CAL control : mechanical mid
- DOLBY NR switch : OFF
- TAPE select switch : TYPE I
- MPX FILTER switch : OFF
- TIMER switch : OFF

- Standard Record:  
Deliver the standard input signal level to the input jack and set the REC LEVEL control to obtain the standard output signal level.

**Standard Input Level**

	LINE IN
source impedance	10kΩ
input level	0.25V (-10dB)

**Standard Output Level**

	LINE OUT
load impedance	47kΩ
output level	0.44V (-5dB)

**Meter Level Adjustment**

Setting:

MONITOR switch: SOURCE

Procedure:

1. Mode: STOP

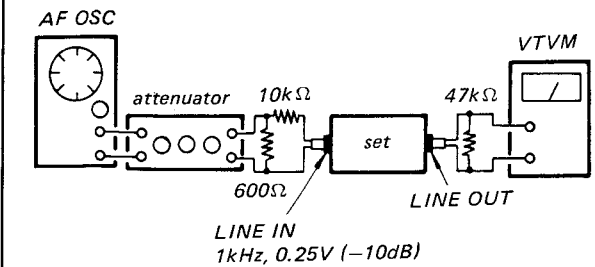

2. Adjust the REC LEVEL control for -6dB (0.39V) LINE OUT level. At this time, adjust RV303 (L-CH) and RV403 (R-CH) for the point where meter 0VU (-5dB) section segments lights up.

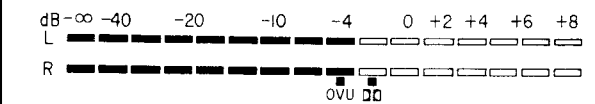

3. Adjust REC LEVEL control for 7dB (1.7V) LINE OUT level. Confirm that all the meter segments light up at this time.

Adjustment Location: record board

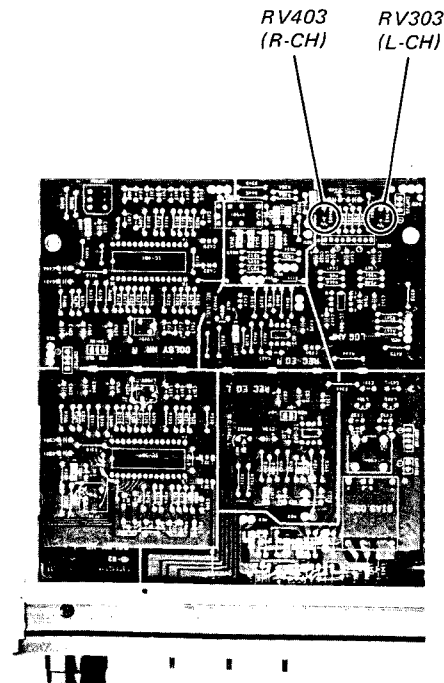

**Capstan Motor Adjustment**

**Procedure:**

1. Mode: stop
2. Set S001 to TEST (turn fully counterclockwise).
3. Connect the oscilloscope to test point TP001 pin ② (H001) and pin ④ (H002) and adjust RV002 (H001) and RV003 (H002) for the specified voltage values.  
..... gain adjustment
4. Next adjust RV004 (H001) and RV005 (H002) for the specified voltage values.  
..... offset adjustment
5. Set S001 to SERVO (turn fully clockwise).
6. Connect the oscilloscope to test point TP001 pin ① and adjust RV001 so that the waveform is as specified.  
..... duty adjustment

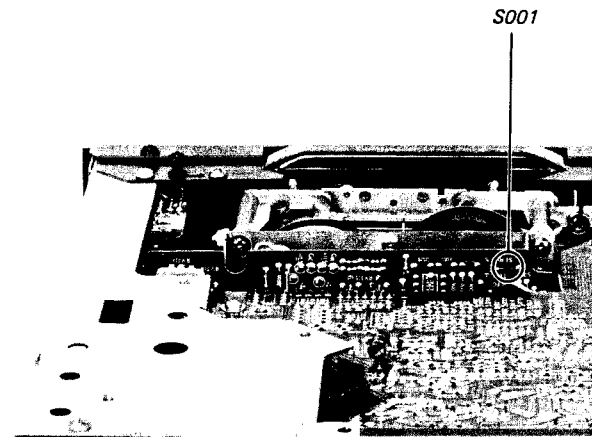

**Specification:**

	measure terminal	adjustment resistor	oscilloscope reading
gain	TP001 ②	RV002	 A = 10 - 10.6Vp-p
	TP001 ④	RV003	
offset	TP001 ②	RV004	 B - C = -0.2 to 0.2V
	TP001 ④	RV005	
duty	TP001 ①	RV001	 E : F = 1 : 3 to 1 : 4 3.8V 2V

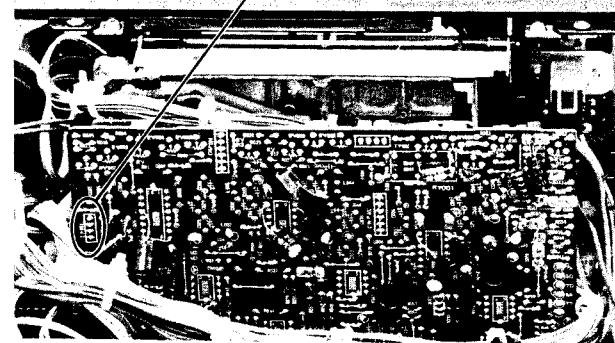
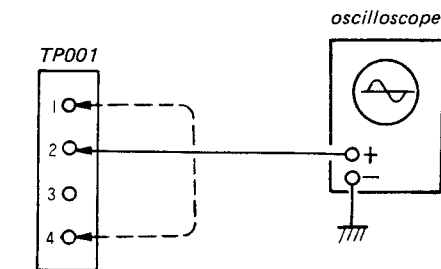

**Adjustment Location: servo board**

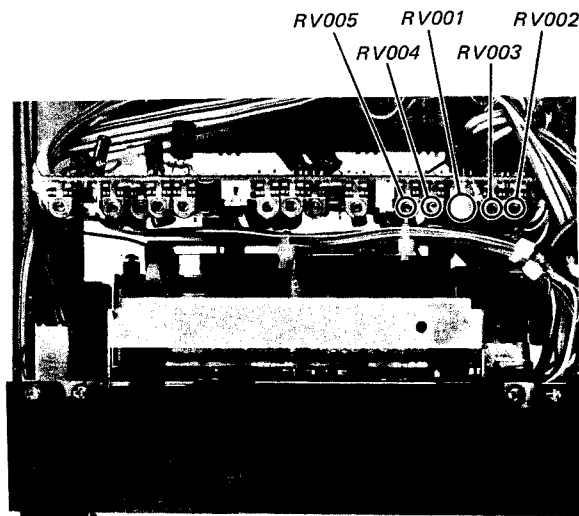

**T-Side Reel Motor Adjustment**

**Procedure:**

1. Confirm that R068, 069 (back mounted) constant is 330Ω. If it is 240Ω, replace with 330Ω.
2. Remove the red lead (D/A output) shown in the figure below and apply 1.5V DC.
3. Turn the cassette detection switch (S002) on without inserting a cassette, and put into fast forward mode.
4. Connect the oscilloscope to test point TP002 pin ③ (H005) and pin ④ (H006), and adjust RV008 (H005) and RV009 (H006) for the specified voltage value.  
..... gain adjustment
5. Next adjust RV012 (H005) and RV013 (H006) for the specified voltage value.  
..... offset adjustment

**Specification:**

	measure terminal	adjustment resistor	oscilloscope reading
gain	TP002 ③	RV008	 A = 15 - 17Vp-p
	TP002 ④	RV009	
offset	TP002 ③	RV012	 B - C = -1 to 1V
	TP002 ④	RV013	

**Adjustment Location: servo board**

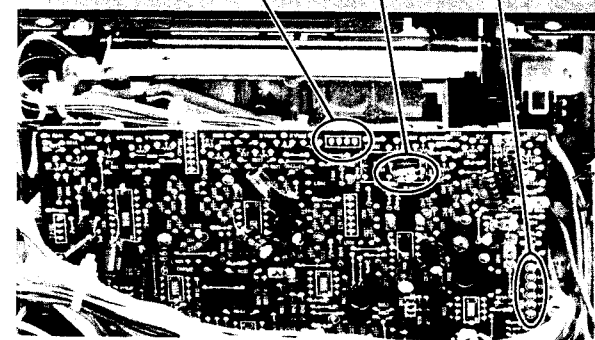
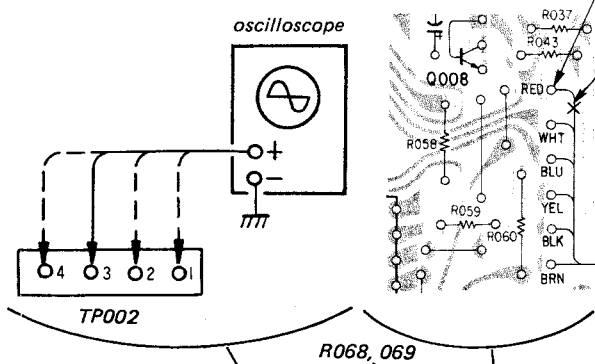

**S-Side Reel Motor Adjustment**

**Procedure:**

1. Confirm that R068, 069 (back mounted) constant is 330Ω. If it is 240Ω, replace with 330Ω.
2. Remove the red lead (D/A output) shown in the figure below and apply 1.5V DC.
3. Turn the cassette detection switch (S002) on without inserting a cassette, and put into rewind mode.
4. Connect the oscilloscope to test point TP002 pin ① (H003) and pin ② (H004) and adjust RV006 (H003) and RV007 (H004) for the specified voltage value.  
..... gain adjustment
5. Next, adjust RV010 (H003) and RV011 (H004) for the specified voltage value.  
..... offset adjustment

**Specification:**

	measure terminal	adjustment resistor	oscilloscope reading
gain	TP002 ①	RV006	 A = 15 - 17Vp-p
	TP002 ②	RV007	
offset	TP002 ①	RV010	 B - C = -1 to 1V
	TP002 ②	RV011	

Apply 1.5V DC.

Remove red lead (D/A output).

cassette detection switch (S002)

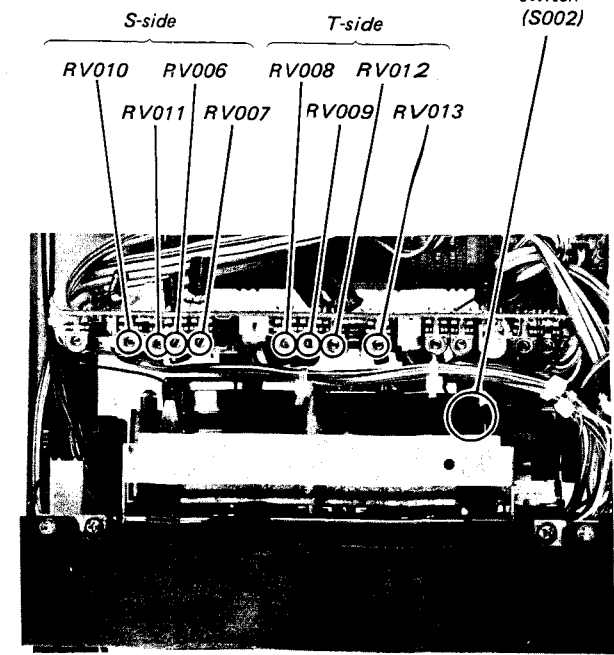

**FWD Torque Adjustment**

**Procedure:**

1. Turn the cassette detection switch (S002) on without inserting a cassette, and put into playback mode.
2. Connect the oscilloscope to test point TP002 pin ③ (H005) and pin ④ (H006) and adjust RV014 so that both pins are the specified voltage value.  
..... gain (FWD torque) adjustment
3. Next, adjust RV012 (H005) and RV013 (H006) for the specified voltage values.  
..... offset adjustment

**Specification:**

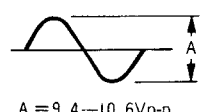
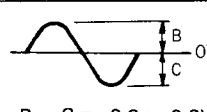
	measure terminal	adjustment resistor	oscilloscope reading
gain (FWD torque)	TP002 ③	RV014	 A = 9.4 -- 10.6Vp-p
	TP002 ④		
offset	TP002 ③	RV012	 B - C = -0.3 to 0.3V
	TP002 ④	RV013	

**Adjustment Location:**  
servo board

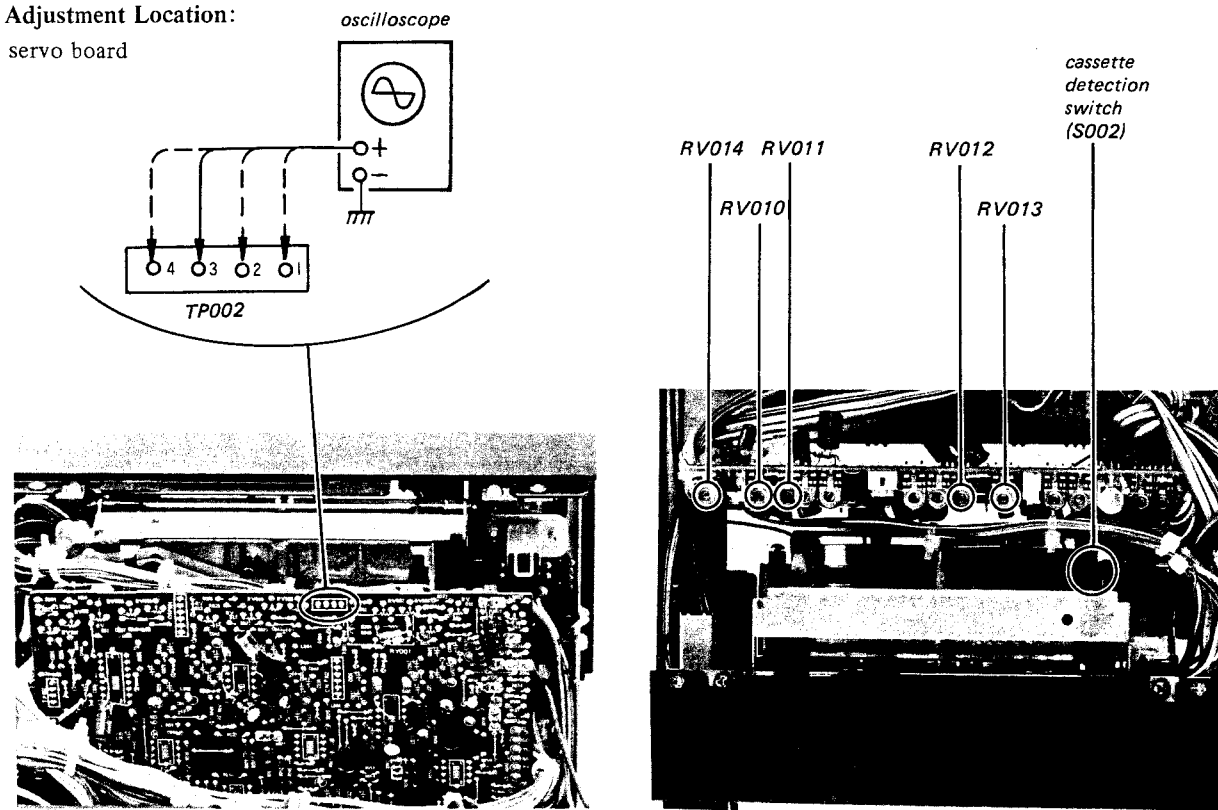

**FWD Back Tension Torque Adjustment**

**Procedure:**

1. Insert a cassette (C-60, etc.) and put into playback mode.
2. Connect the oscilloscope to test point TP002 pin ① (H003) and pin ② (H004) and adjust RV010 (H003) and RV011 (H004) for the specified voltage values.

**Specification:**

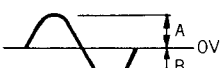
measure terminal	adjustment resistor	oscilloscope reading
TP002 ①	RV010	 A - B = -0.3 to 0.3V
TP002 ②	RV011	

**Sensor Offset Adjustment**

**Procedure:**

1. Insert a cassette and put into fast forward mode.
2. Connect the oscilloscope to test point TP701 pins ④ and ③. Adjust RV015 and RV016 so that the waveforms of both pins are as specified.
3. Next put into rewind mode.
4. Connect the oscilloscope to test point TP701 pins ② and ① and adjust RV017 and RV018 so that the waveforms of both pins are as specified.

**Specification:**

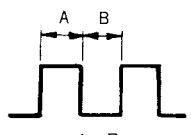
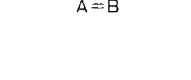
mode	measure terminal	adjustment resistor	oscilloscope reading
FF	TP701 ④	RV015	 A B
	TP701 ③	RV016	
REW	TP701 ②	RV017	 A=B
	TP701 ①	RV018	

**Adjustment Location:** servo board

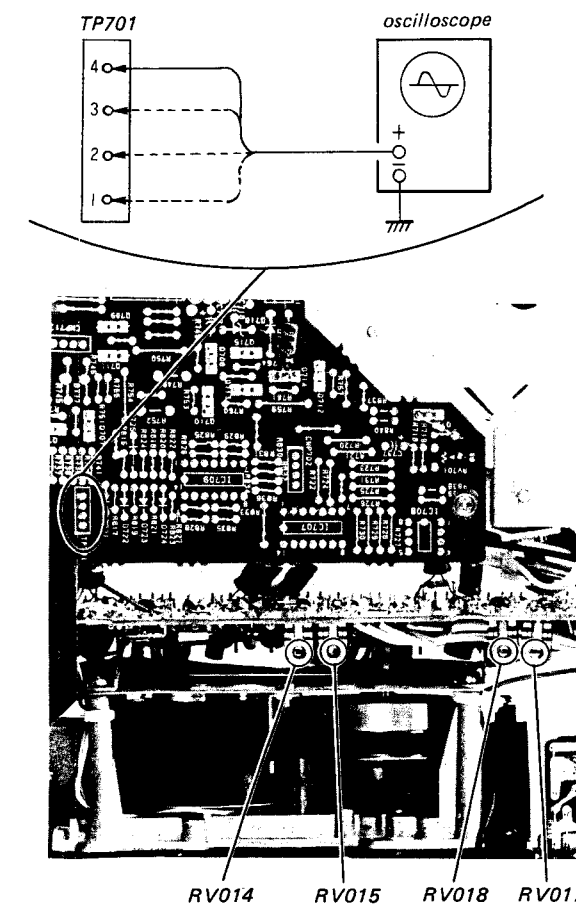

**Reel Motor Control Voltage (D/A output) Adjustment**

**Procedure:**

1. Turn the cassette detection switch (S002) on without inserting a cassette and put into fast forward or rewind mode.
2. Connect the oscilloscope to IC708 pin ① and adjust RV701 for the specified voltage value.

**Specification:** 3.9 - 4.1V dc

cassette detection switch (S002)

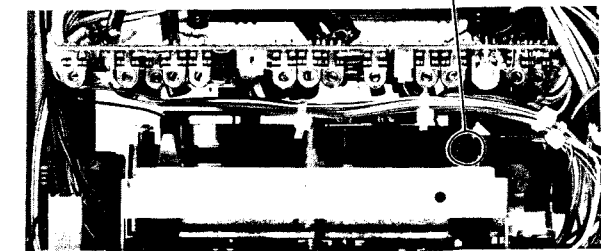

**Adjustment Location:** system control board

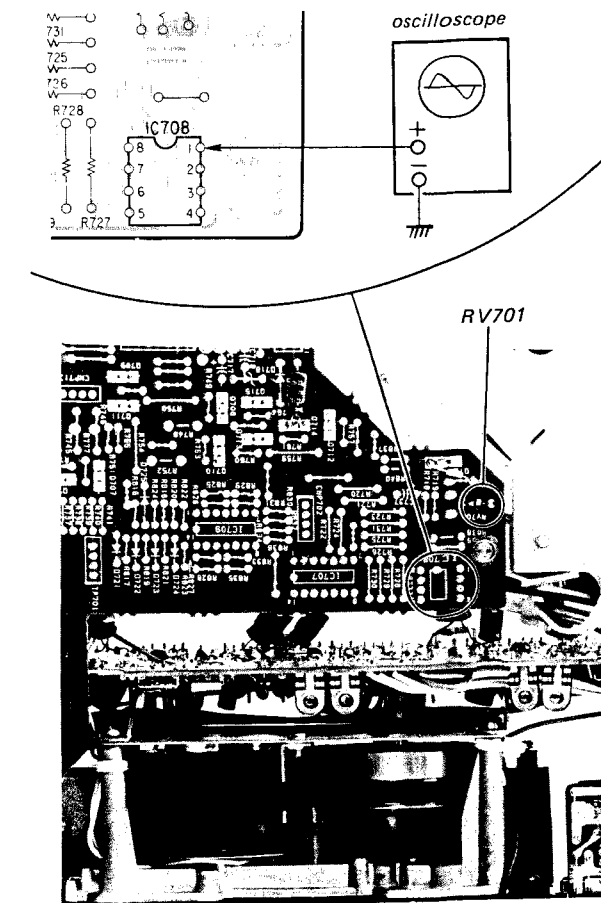

**Playback Amp Offset Adjustment**

**Procedure:** – stop mode –

Connect the oscilloscope to IC501 pin ⑦ (L-CH) and pin ① (R-CH).

Adjust RV101 (L-CH) and RV201 (R-CH) for the specified voltage values.

**Specification:** –0.1 to 0.1V dc

**Adjustment Location:** playback board

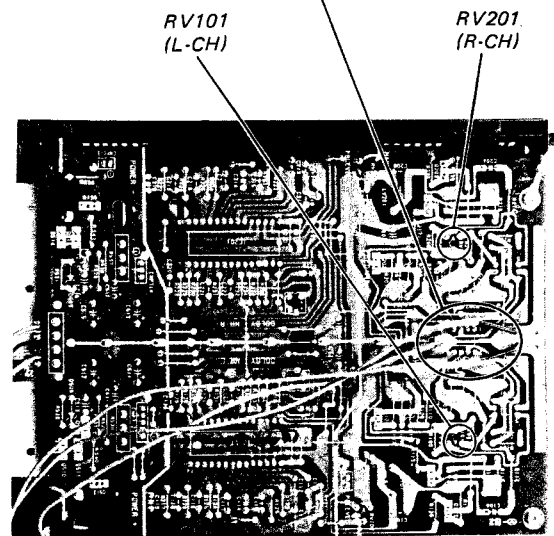
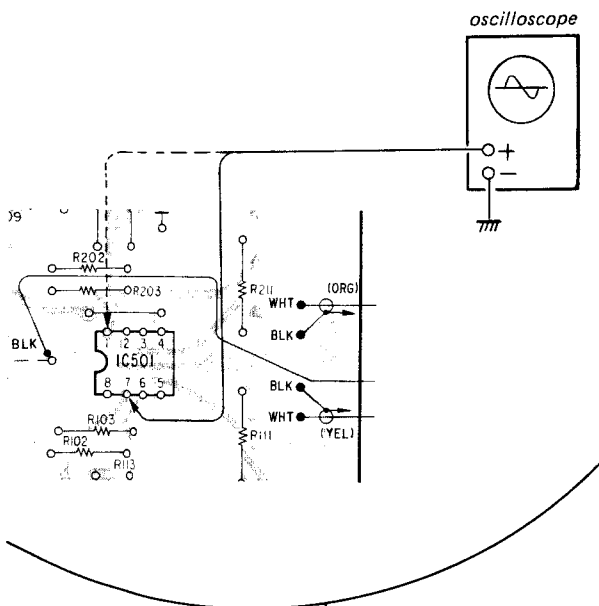

**Playback Head Azimuth Adjustment**

**Procedure:**

1. Mode: playback

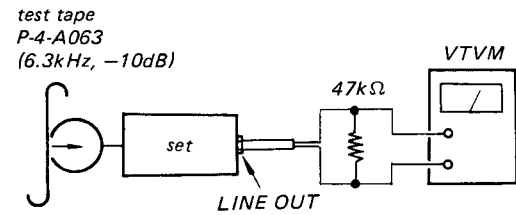

2. Adjust the lock nut so that L-CH and R-CH output is maximum. When the maximum points of L-CH and R-CH are not the same, adjust to the point where they match within 0.5dB of each channel's maximum output value.

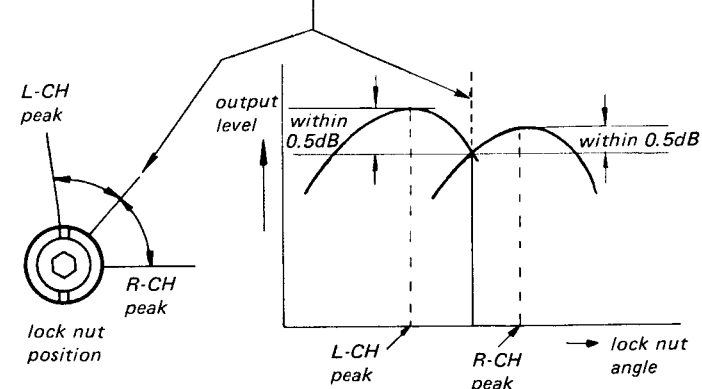

3. Phase Check

Mode: playback

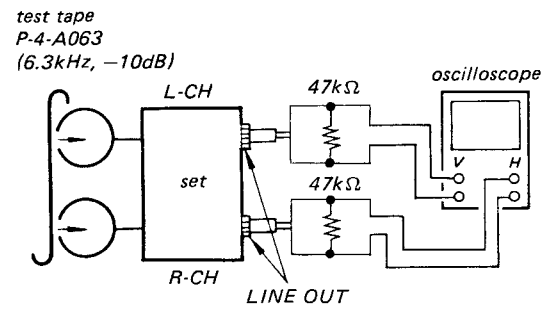

4. Confirm that L-CH and R-CH phase difference is between in-phase and 90°.

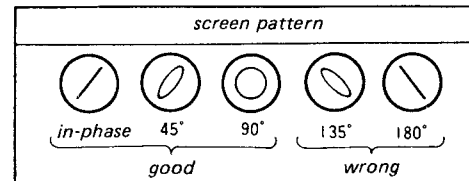

**Adjustment Location:**

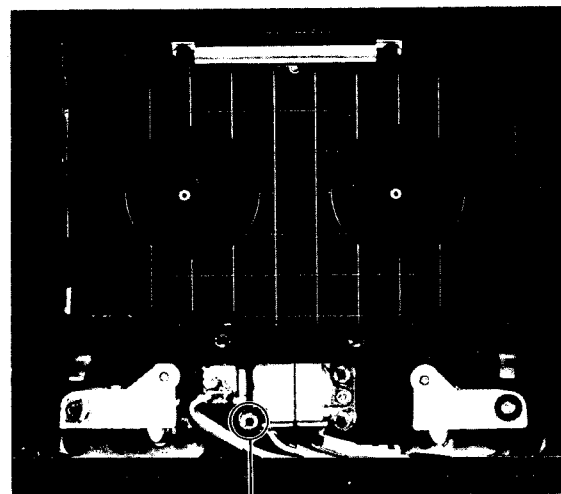

lock nut  
hexagon-socket set screw 2 x 3  
Loosen the hexagonal socket set screw and adjust with the lock nut. After adjusting, tighten the hexagonal socket set screw without turning the lock nut.

**Playback Level Adjustment**

**Procedure:**

1. Mode: playback

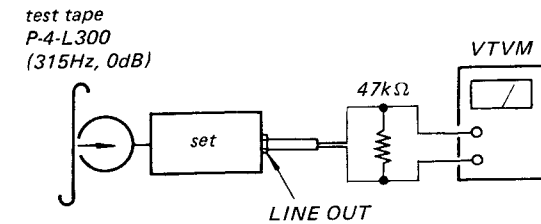

2. Adjust RV102 (L-CH) and RV202 (R-CH) to obtain the specified LINE OUT level.

**Specification:** LINE OUT level: 0.42 – 0.46V  
(–5.5 to –4.5dB)  
Level difference between channels:  
less than 0.5dB

**Adjustment Location:** playback board

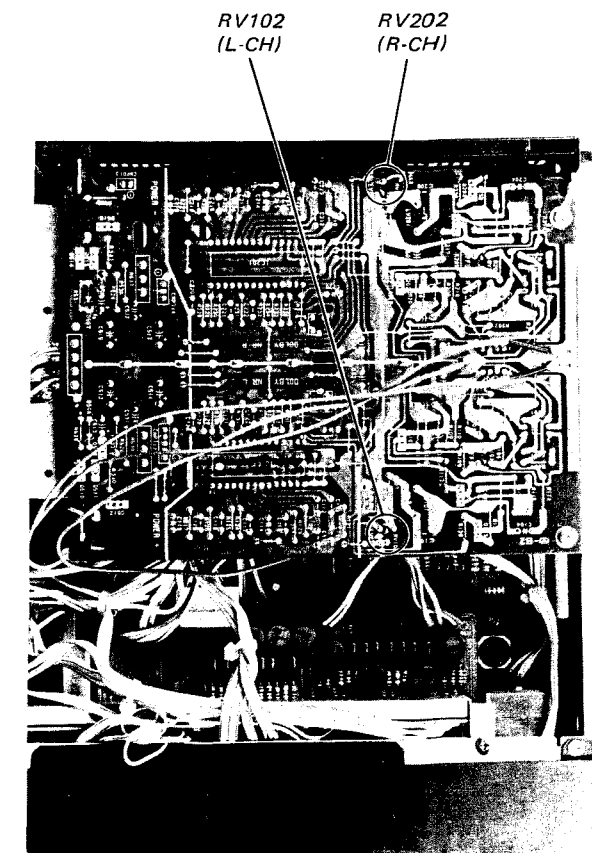



**Record Bias OSC Frequency and Bias Trap Adjustment**

**Setting:**

TAPE select switch: TYPE IV

**Procedure:**

1. Mode: record (no signal)

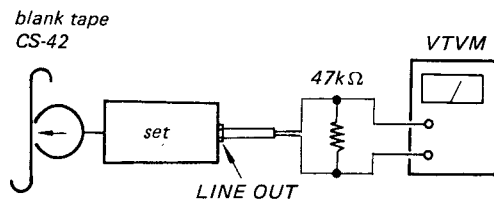

2. Connect the frequency counter to bias OSC unit pin ④. Adjust the bias OSC unit core (red) so that bias OSC frequency is 100 – 110kHz.

**Note:** Do not move the brown core.

3. Set the MONITOR switch to TAPE and adjust LV101 (L-CH) and LV201 (R-CH) so that bias leaking to LINE OUT level is minimum. The value at this time should be less than 4.4mV (less than -45dB).

**Adjustment Location:** record board  
playback board

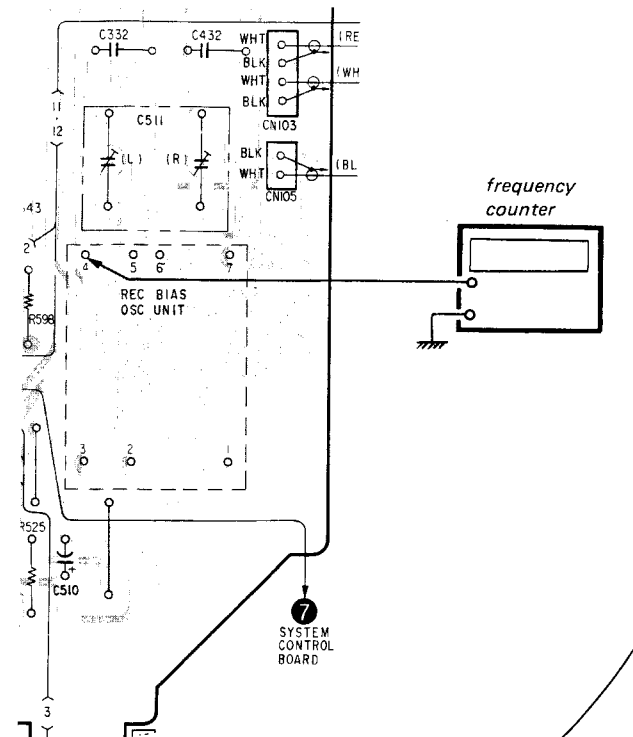

rec core of bias OSC unit  
LV101 (L-CH)  
LV201 (R-CH)

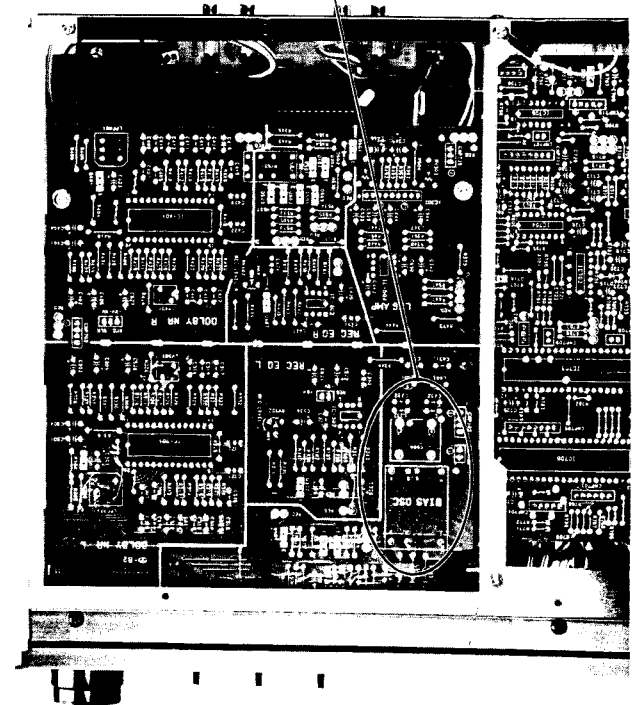
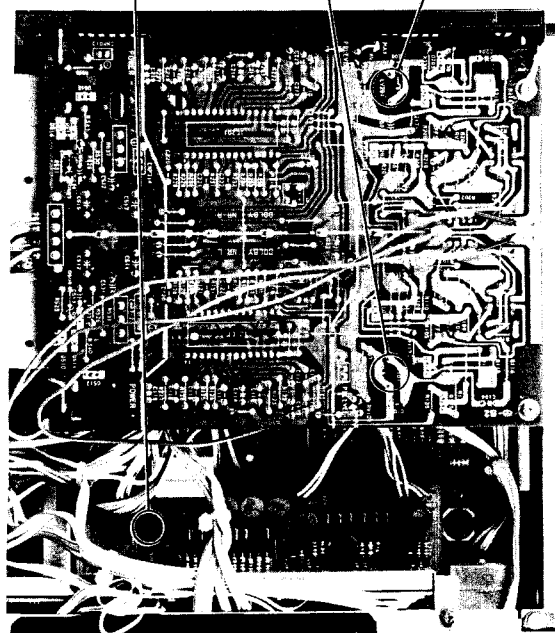

**Record Head Azimuth Temporary Adjustment**

**Setting:**

REC LEVEL control: standard record  
(See page 28.)

**Procedure:**

1. Loosen C511 (L-CH, R-CH) 1/2 – 1 turn after tightening completely.

2. Mode: record

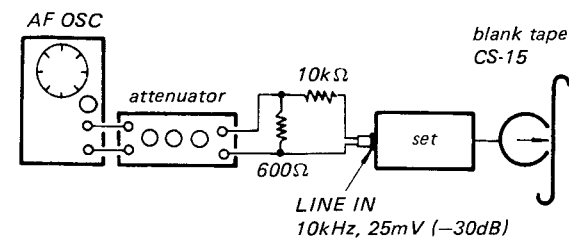

3. Mode: playback

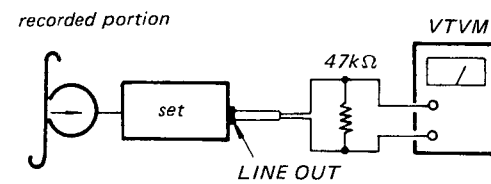

**Adjustment Location:**

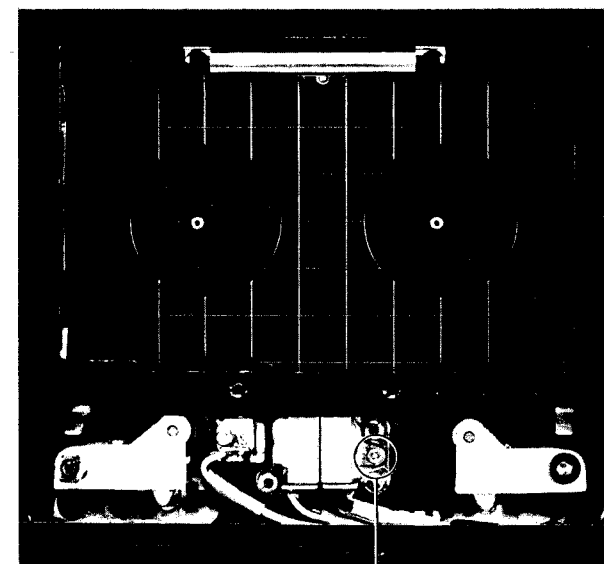

adjustment screw

4. Adjust the screw for maximum L-CH, R-CH output.

5. When the maximum points of L-CH and R-CH output are not the same, adjust the screw so that they match, and so that the level down amount is the same for both channels.

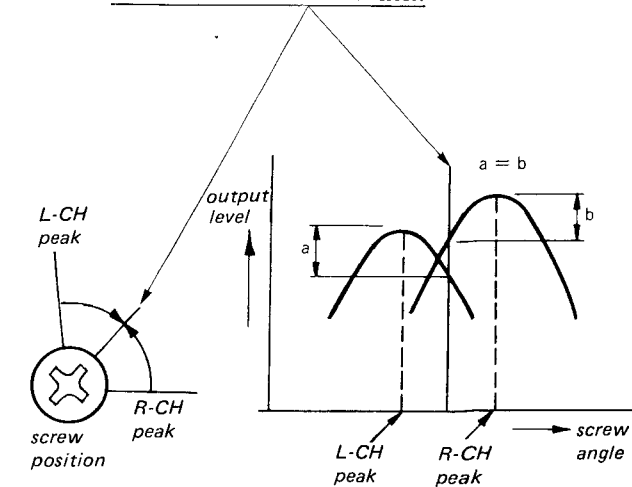



- Perform Record Level and Record Bias Adjustments after completing Record Head Azimuth Temporary Adjustment.

## Record Level Adjustment

### Setting:

REC LEVEL control: standard record  
(See page 28.)

### Procedure:

1. Mode: record

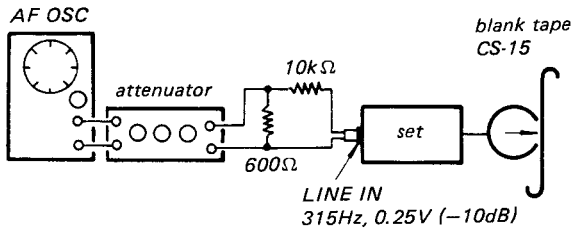

2. Mode: playback

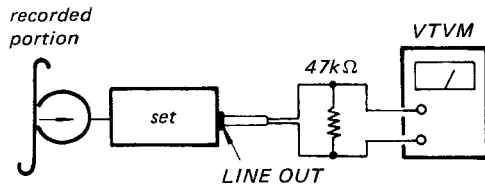

3. Adjust RV302 (L-CH) and RV402 (R-CH) to obtain the specified LINE OUT level.

### Specification:

LINE OUT level: 0.42 – 0.46V  
(-5.5 to -4.5dB)

Adjustment Location: record board

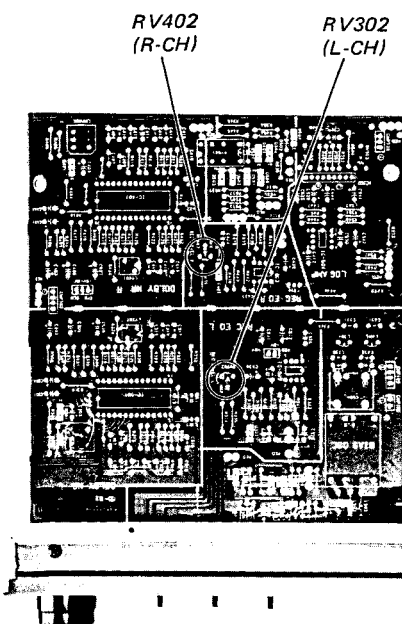

## Record Bias Adjustment

### Setting:

REC LEVEL control: standard record  
(See page 28.)

### Procedure:

1. Mode: record

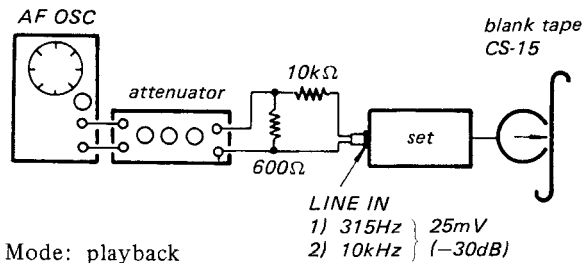

2. Mode: playback

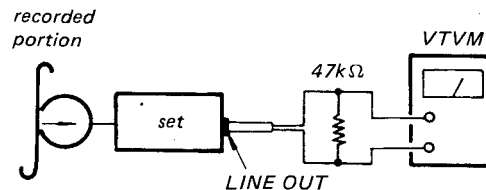

3. Adjust C511 (L-CH and R-CH) so that the LINE OUT level of 10kHz signal is  $0 \pm 0.5$ dB relative to that of 315Hz.

**Note:** Be sure to finish adjusting C511 by turning them clockwise.

Adjustment Location: record board

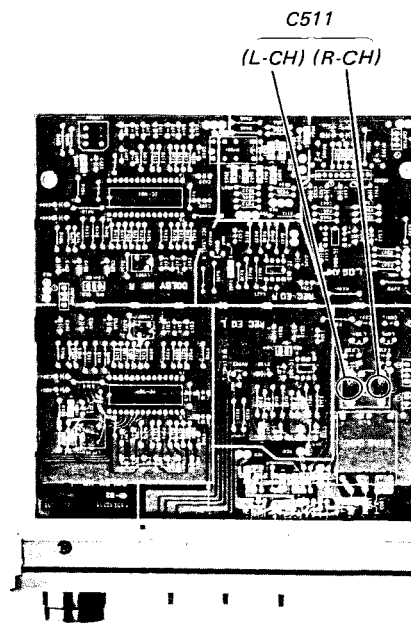

## Record Head Azimuth Main Adjustment

### Setting:

REC LEVEL control: standard record  
(See page 28.)

### Procedure:

1. Mode: record

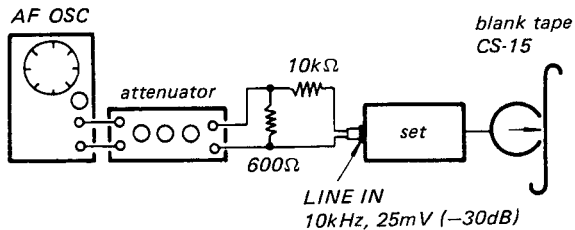

2. Mode: playback

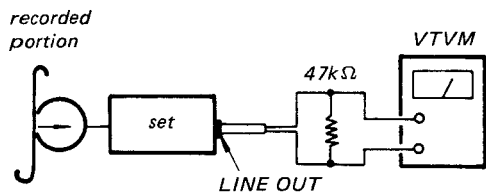

3. Adjust the screw for maximum L-CH, R-CH output.
4. When L-CH and R-CH output maximum values are not the same, adjust the screw so that they match, within 1dB level down from the maximum value.

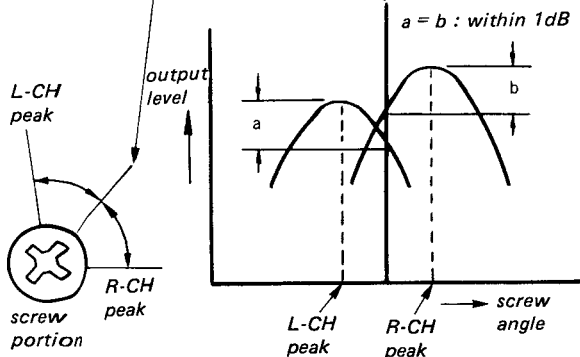

5. Phase Check

Mode: playback

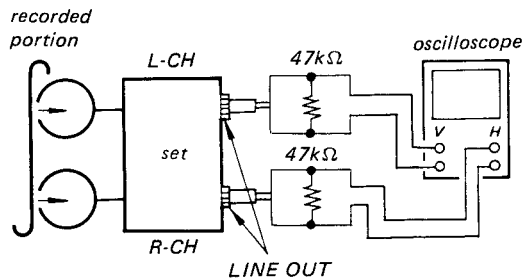

6. Confirm that L-CH and R-CH phase difference is between in-phase and 90°.

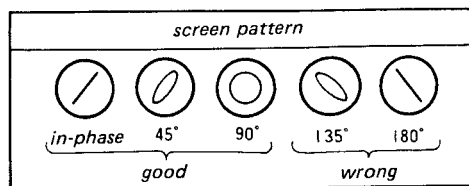

### Adjustment Location:

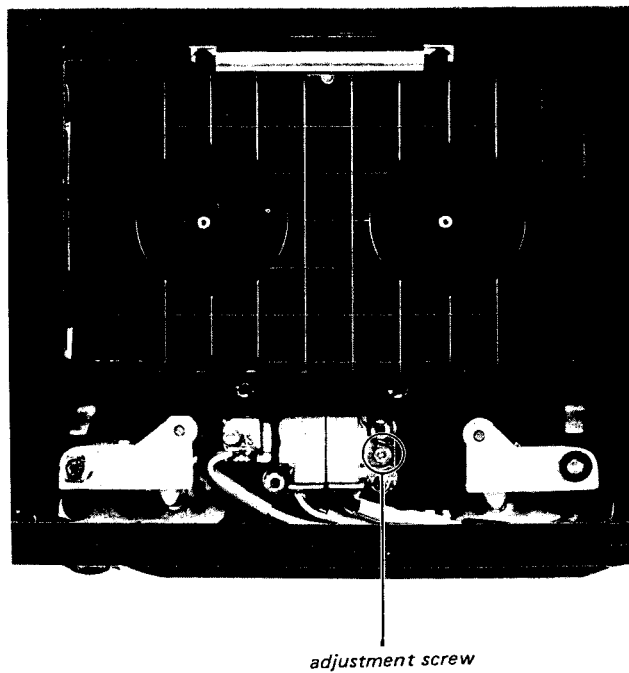



IC603	
Waveform or Voltage	

Voltages and Waveforms at the Terminals of IC703					
Terminal No.	Waveform or Voltage	Terminal No.	Waveform or Voltage	Terminal No.	Waveform or Voltage
①	head solenoid drive signal 3.2V 0.2sec FWD button ON	⑮	TIMER switch { REC: 0V OFF: 5.1V	③①	REW mode dual-speed REW mode 5.2V 4msec
②	5.2V 0.01V FWD or REC mode	⑰	TIMER switch { PLAY: 0V OFF: 5.1V	③②	MONITOR switch lamp drive signal 2.6V 0V SOURCE mode
③	brake solenoid drive signal 3.2V 0.2sec FWD button ON	⑱	cassette half detection switch OFF 5.1V 0V	③③	4.3V 0V FWD or FF mode
④	5.2V 0.01V FWD, REC, FF or REW mode	⑳	MONITOR switch kept pressed 5.1V 0V	③④	4.3V 0V REC or REW mode
⑤	cueing mode 3.8V 0V	㉑	GND	③⑤	4.3V 0V FWD or REC mode
⑥	5V 0V MONITOR switch SOURCE	㉒	clock signal 5.5Vp-p 0.28µsec	③⑥	4.3V 0V FWD button kept pressed
⑦	record muting signal 3.5V 0V REC MUTE button ON in REC mode	㉓	not used in this set	③⑦	3.7V 0V FWD or REC mode
⑧	4.5V 0V REC mode	㉔	reset signal: 4.8V	③⑧	dual-speed FF or dual-speed REW mode 4.3V 0V
⑨	GND	㉕	0.045V	③⑨	not used in this set
⑩	GND	㉖	B+ supply voltage: 6V	④①	4V 0V 0.13msec
⑪	GND	⑲	PAUSE lamp drive signal 5.2V 0V PAUSE mode	④②	B+ supply voltage: 5.2V
⑫	1.6µsec 130µsec 5.2V 0V	⑳	REC lamp drive signal 5.2V 0V REC mode		
⑬	11µsec 130µsec 5.2V 0V	㉑	FF mode dual-speed FF mode 5.2V 4msec		
⑭		㉒	FWD lamp drive signal 5.2V 0V FWD mode		

Voltages and Waveforms at the Terminals of IC706					
Terminal No.	Waveform or Voltage	Terminal No.	Waveform or Voltage	Terminal No.	Waveform or Voltage
①	drive signal for "DP" (dot), "-" (minus), and "MEMORY" of fluorescent display tube 0.8msec 3.5msec 4V 0V	⑰	4.3V 0V FWD or REC mode	③⑩	4.3V 0V FWD or REC mode
②	1) "DP" (dot) display 2) "DP" (dot) and "-" (minus) or "DP" (dot) and "MEMORY" display 3) "DP" (dot), "-" (minus) and "MEMORY" display 0.8msec 3.5msec 4V 0V	⑱	4.3V 0V REC or REW mode	③⑪	4.3V 0V FWD or FF mode
③	drive signal for "a" segment of fluorescent display tube. 1) in case of all "a" segments are not lit, i.e., all of the four digits are "1" or "4". 2) in case of only one out of four "a" segments lit, i.e., one of the four digits is "0", "2", "3", "5", "6", "7", "8", or "9" and all others are "1" or "4". 3) in case of only two out of four "a" segments lit as in the case of 2) above. 4) in case of only three out of four "a" segments lit as in the case of 2) above. 5) in case of all of the four "a" segments lit likewise. 0.8msec 3.5msec 4V 0V	㉑	GND	③⑫	clock signal 0.28µsec
④	drive signal for "b" segments of fluorescent display tube same as terminal ② for segment "a".	㉒	not used in this set	③⑬	not used in this set
⑤	drive signal for "c" segments of fluorescent display tube same as terminal ② for segment "a".	㉓	reset signal: 4.8V	③⑭	MEMORY or RESET switch kept 3.5msec
⑥	drive signal for "d" segments of fluorescent display tube same as terminal ② for segment "a".	㉔	0.045V	③⑮	dual-speed FF or dual-sp 4.3V 0V
⑦	drive signal for "e" segments of fluorescent display tube same as terminal ② for segment "a".	㉕	B+ supply voltage: 6V	③⑯	GND
⑧	drive signal for "f" segments of fluorescent display tube same as terminal ② for segment "a".	㉖	0.045V	③⑰	0.045V
⑨	drive signal for "g" segments of fluorescent display tube same as terminal ② for segment "a".	㉗	5.1V	③⑱	5.1V
⑩	GND	㉘	5.1V	③⑲	1.95V
⑪	GND	㉙	1.95V	③⑳	1.95V
⑫	FF or REW mode 5V 0V The pulse width is vary by the tape speed.	㉚	0V or 4.2V	③㉑	0V or 4.2V
⑬	4.3V 0V REW button kept pressed	㉛	drive signal for grid G4— G7 of fl 1.8msec	③㉒	drive signal for grid G4— G7 of fl 3.6msec
⑭		㉜	B+ supply voltage: 5.2V	③㉓	B+ supply voltage: 5.2V
⑮		㉝		③㉔	4.3V 0V 0.9msec

Signals at the Terminals of IC703

Form or Voltage	Terminal No.	Waveform or Voltage
Switch { REC : 0V OFF : 5.1V	31	
Switch { PLAY : 0V OFF : 5.1V	32	MONITOR switch lamp drive signal 
Pause half detection switch OFF	33	
Monitor switch pressed	34	
Clock signal	35	
Not used in this set	36	
Reset signal: 4.8V	37	
Lamp drive signal	38	dual-speed FF or dual-speed REW mode 
Not used in this set	39	not used in this set
Lamp drive signal	40	
Lamp drive signal	41	
B+ supply voltage: 6V	42	B+ supply voltage: 5.2V

Voltages and Waveforms at the Terminals of IC706

Terminal No.	Waveform or Voltage	Terminal No.	Waveform or Voltage
1	drive signal for "DP" (dot), "-" (minus), and "MEMORY" of fluorescent display tube 	17	
2	drive signal for "a" segment of fluorescent display tube. 1) in case of all "a" segments are not lit, i.e., all of the four digits are "1" or "4". 2) in case of only one out of four "a" segments lit, i.e., one of the four digits is "0", "2", "3", "5", "6", "7", "8", or "9" and all others are "1" or "4". 3) in case of only two out of four "a" segments lit as in the case of 2) above. 4) in case of only three out of four "a" segments lit as in the case of 2) above. 5) in case of all of the four "a" segments lit likewise.	18	
3	drive signal for "b" segments of fluorescent display tube same as terminal 2 for segment "a".	19	
4	drive signal for "c" segments of fluorescent display tube same as terminal 2 for segment "a".	20	GND
5	drive signal for "d" segments of fluorescent display tube same as terminal 2 for segment "a".	21	GND
6	drive signal for "e" segments of fluorescent display tube same as terminal 2 for segment "a".	22	clock signal 
7	drive signal for "f" segments of fluorescent display tube same as terminal 2 for segment "a".	23	not used in this set
8	drive signal for "g" segments of fluorescent display tube same as terminal 2 for segment "a".	24	reset signal: 4.8V
9	GND	25	MEMORY or RESET switch kept pressed 
10	GND	26	dual-speed FF or dual-speed REW mode 
11	FF or REW mode The pulse width is vary by the tape speed.	27	GND
12		28	0.045V
13		29	5.1V
14		30	5.1V
15		31	1.95V
16		32	1.95V
		33	0V or 4.2V
		34	drive signal for grid G4 - G7 of fluorescent display tube 
		35	drive signal for grid G4 - G7 of fluorescent display tube 
		36	B+ supply voltage: 5.2V.
		37	

SECTION 4  
DIAGRAMS

Semiconductor Lead Layouts

CX20087  
CX20088  
NJM4560D  
NJM2043D-D  
μPC4557C  
μPC4558C

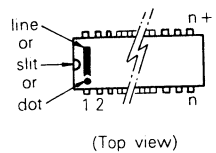

BA6138

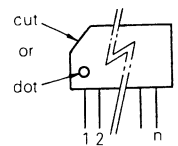

2SC1364  
2SC1364-8  
2SD666A  
2SC1345  
2SC2001  
2SC1815-GR

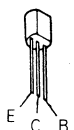

2SK245

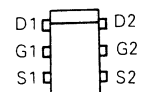

Circuit Boards Location

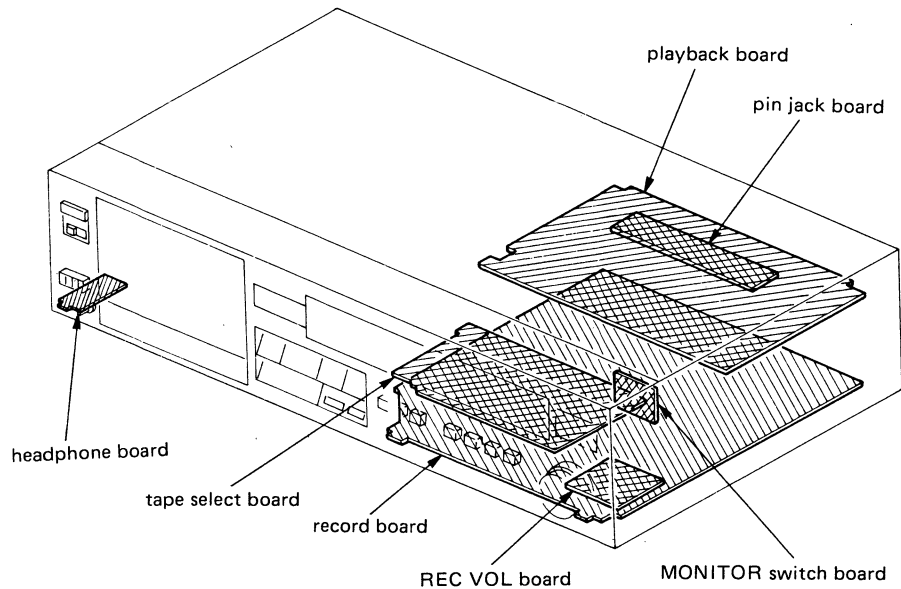

2SA1026-7

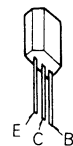

2SK120-2

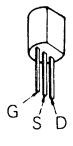

2SC2676  
2SA1138

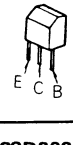

2SD809  
2SB731

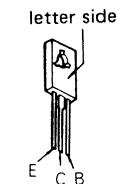

HZ6B1L  
1S1555

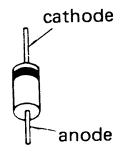

Note:

- Color code of sleeving over the end of the jacket.

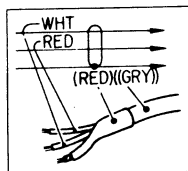

- : parts extracted from the component side.
- : parts extracted from the conductor side.
- ▨ : B+ pattern
- ▩ : B- pattern
- : signal path
- : L-CH signal path
- : R-CH signal path

4-1. AMP SECTION MOUNTING DIAGRAM

- Conductor Side -

TC-K666ES

TC-K666ES

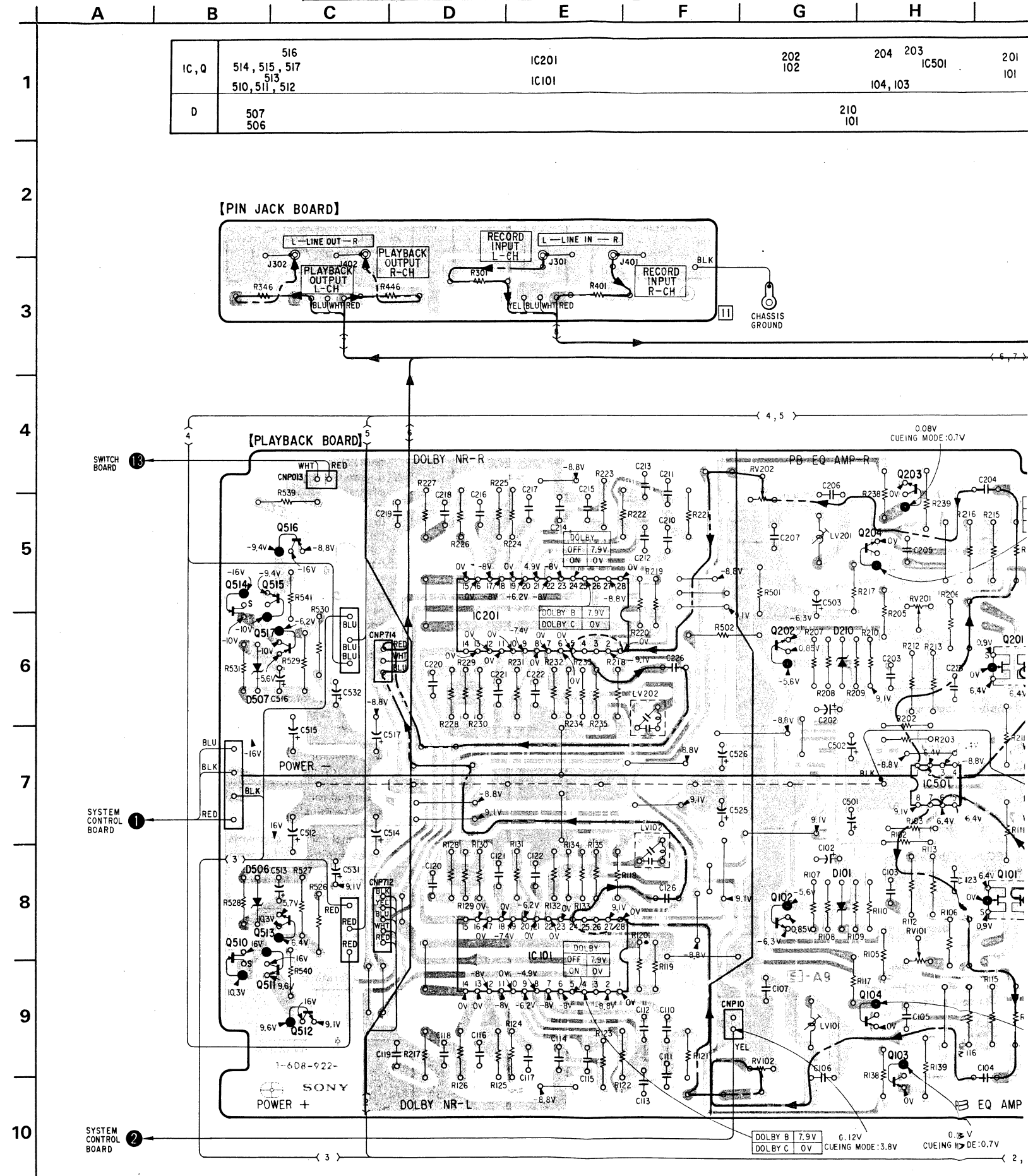



202 102 204 104, 103 203 IC501 201 101 401 301 IC401 IC301 503 402 502 302 501 507 404, 304 505 IC402 IC302 504 509, 508 501 502 505, 504 IC502 IC504

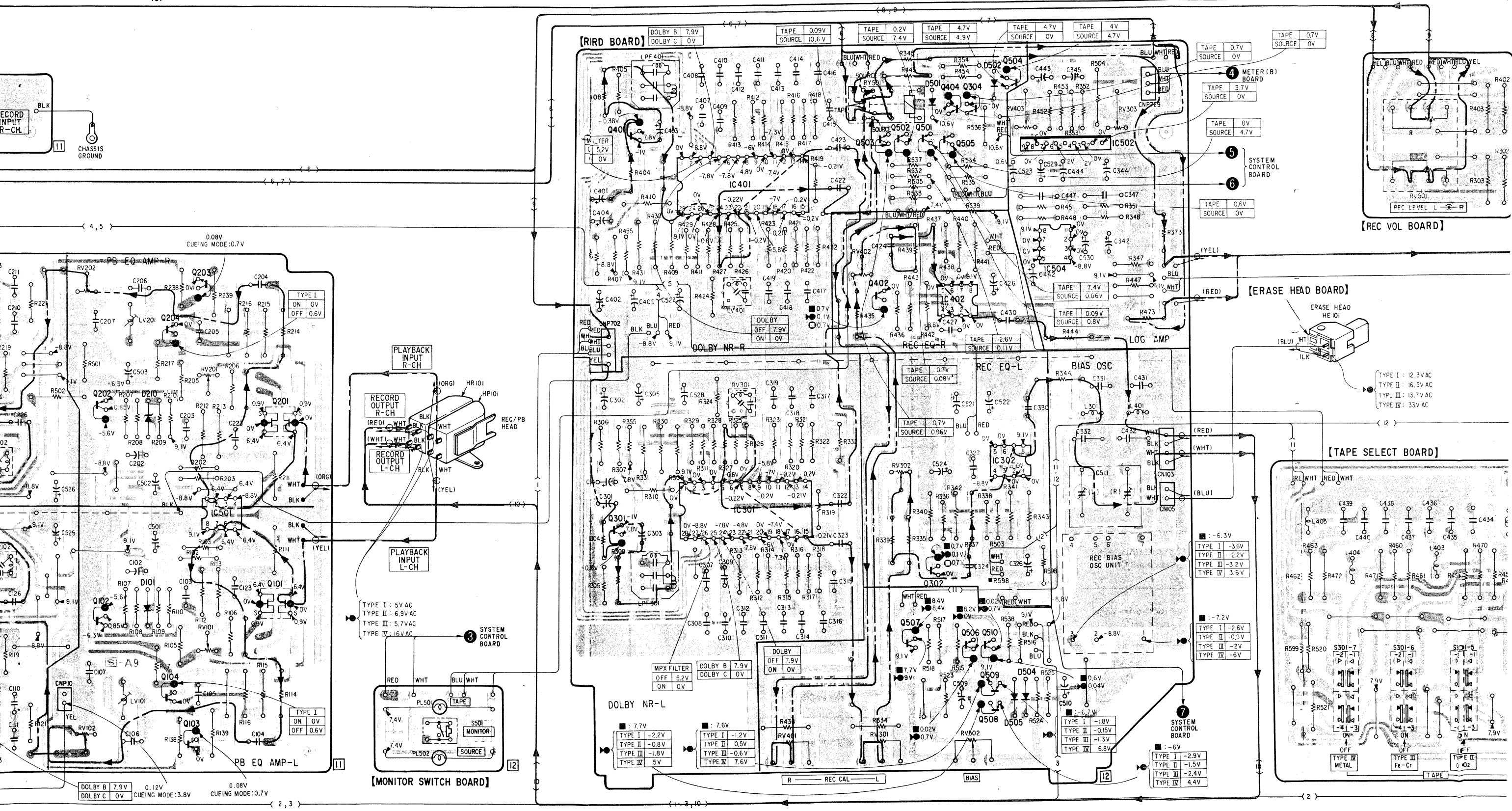





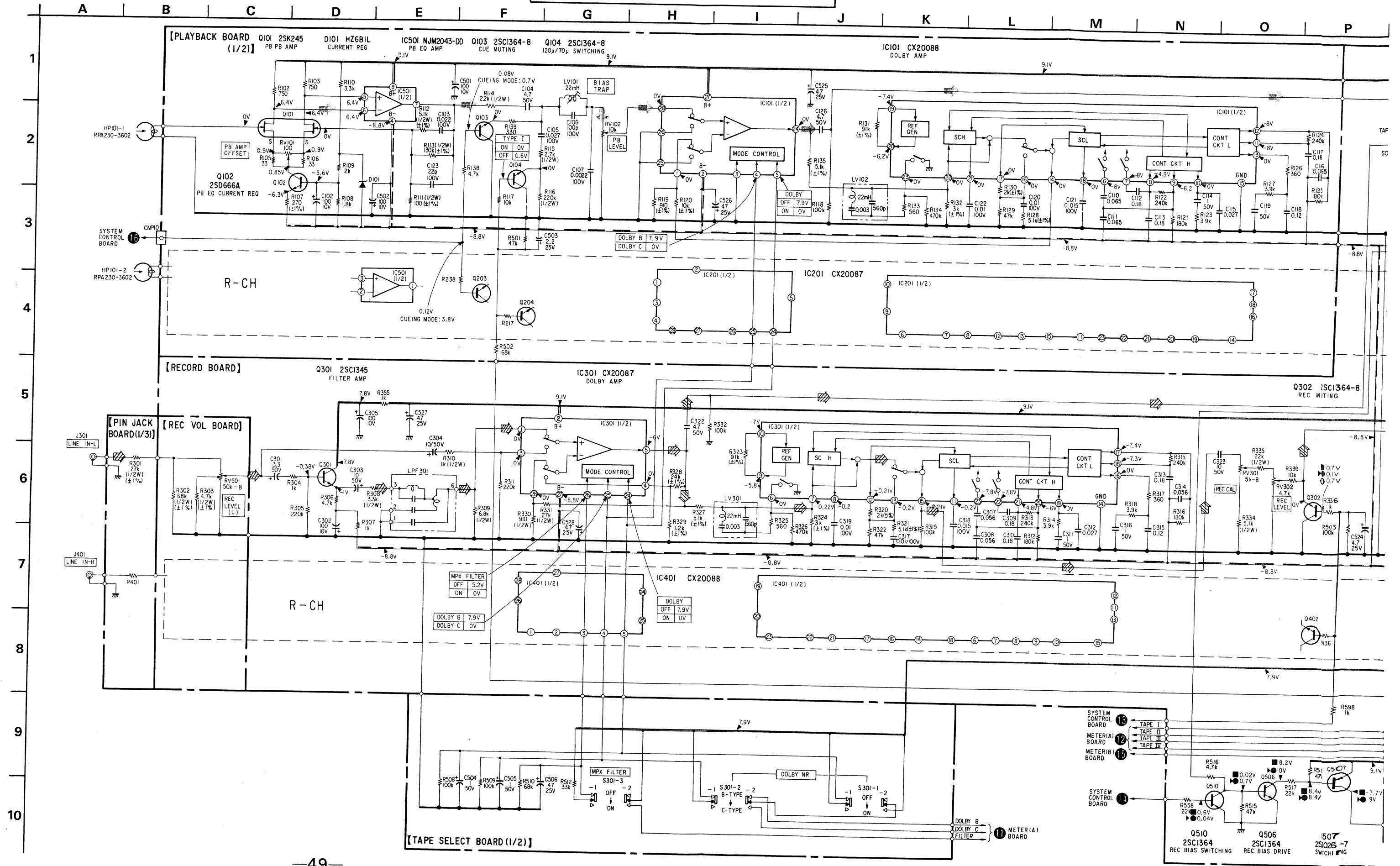



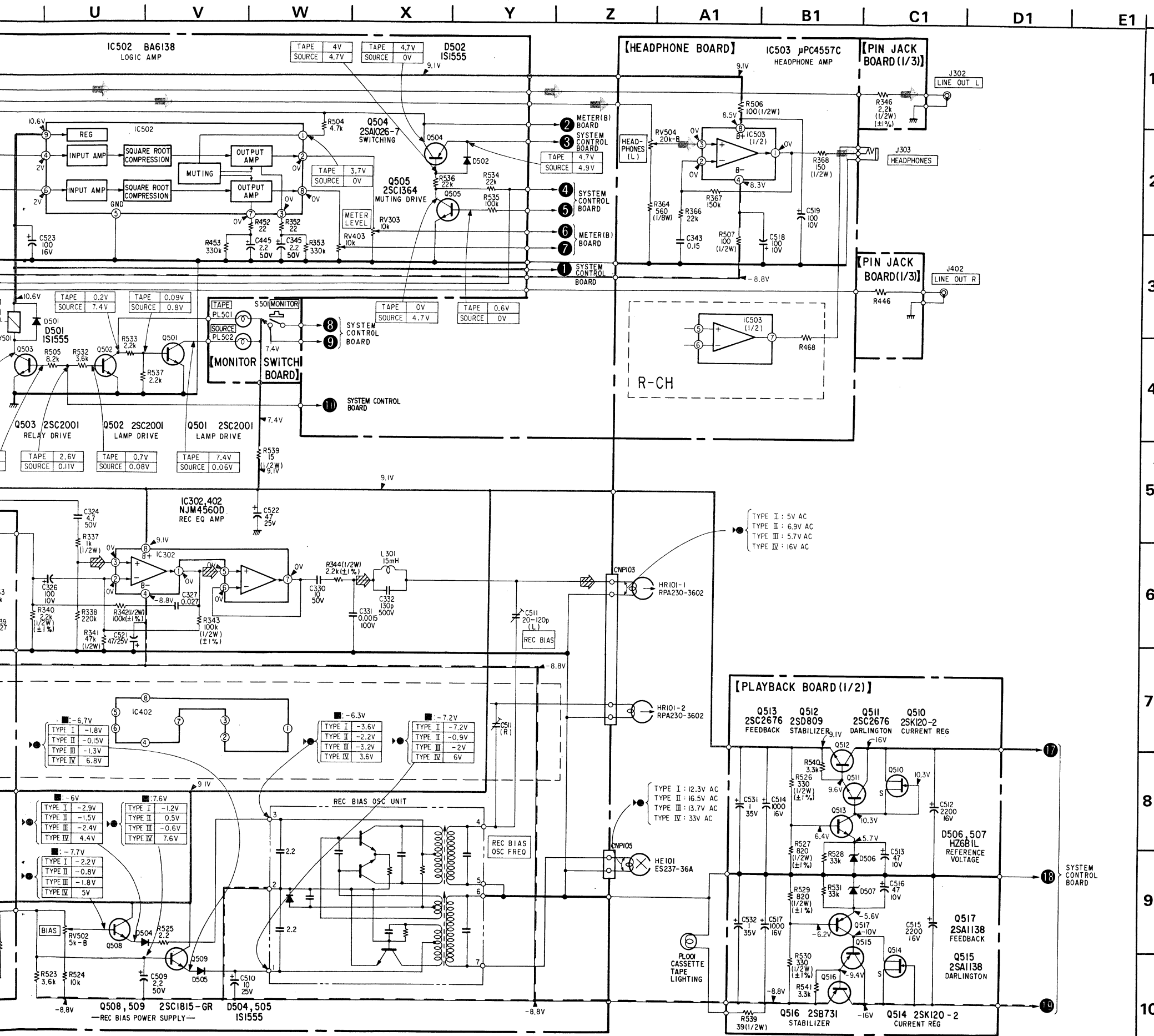

Note:

- Components for right channel have same values as for left channel. Reference numbers are coded from 201, 401.
- All capacitors are in μF unless otherwise noted. pF : μμF 50WV or less are not indicated except for electrolytics and tantalums.
- All resistors are in ohms, ¼W unless otherwise noted. kΩ : 1000 Ω, MΩ : 1000 kΩ
- □ : adjustment for repair.
- — : B+ bus.
- - - - : B- bus.
- Voltages are dc with respect to ground unless otherwise noted.
- Readings are taken under STOP mode.
- : STOP
- ▶ : FWD
- ▶▶ : FF
- dual-speed ▶▶ : dual-speed FF
- ◀◀ : REW
- dual-speed ◀◀ : dual-speed REW
- : REC
- ◐ : REC
- : REC MUTE
- || : PAUSE

- Voltage variations may be noted due to normal production tolerances.
- AC voltage readings with a VTVM.
- Signal path
- ▣ : playback
- ▤ : record

Note: Voltages are measured with a VOM (50kΩ/V).

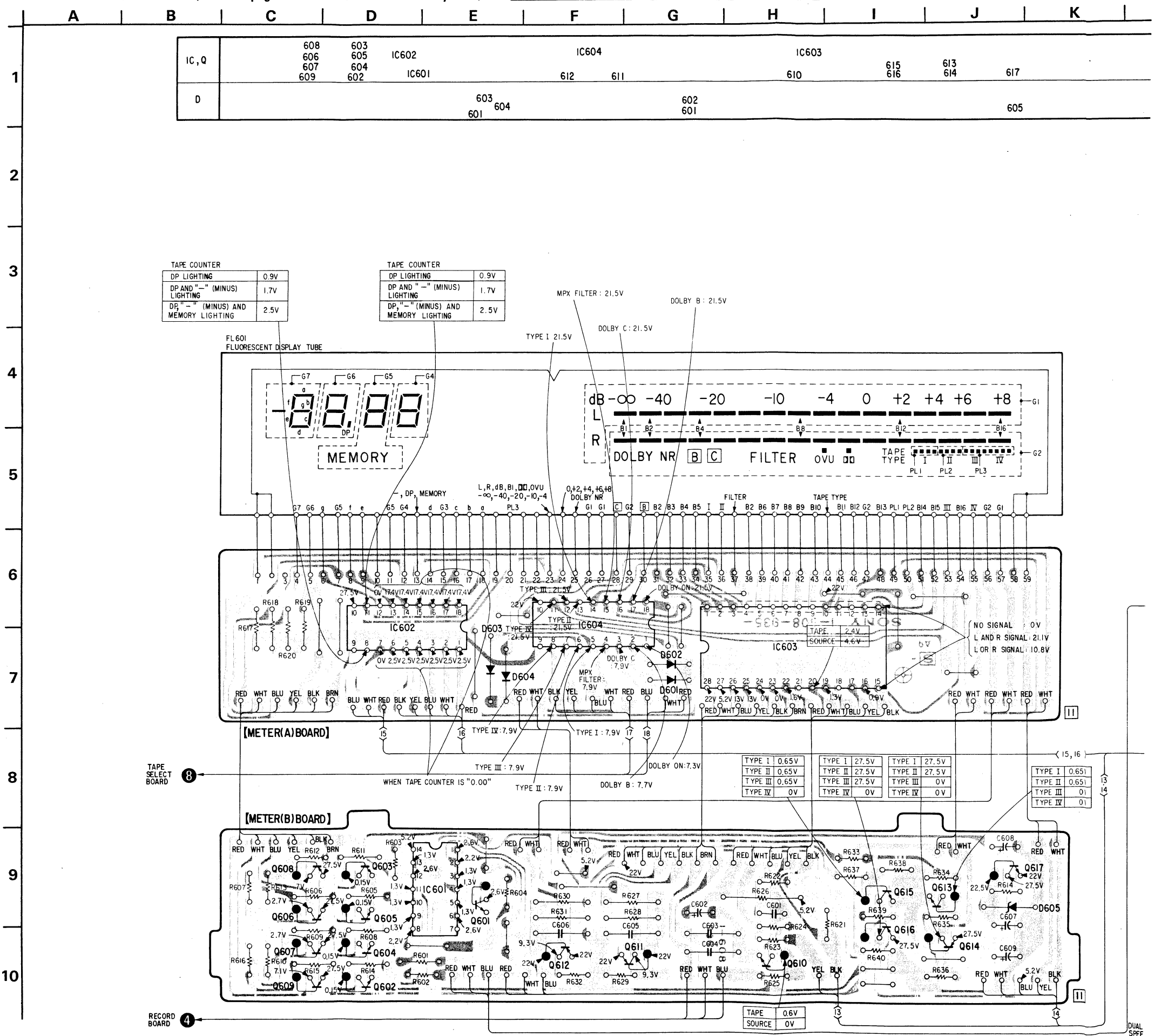
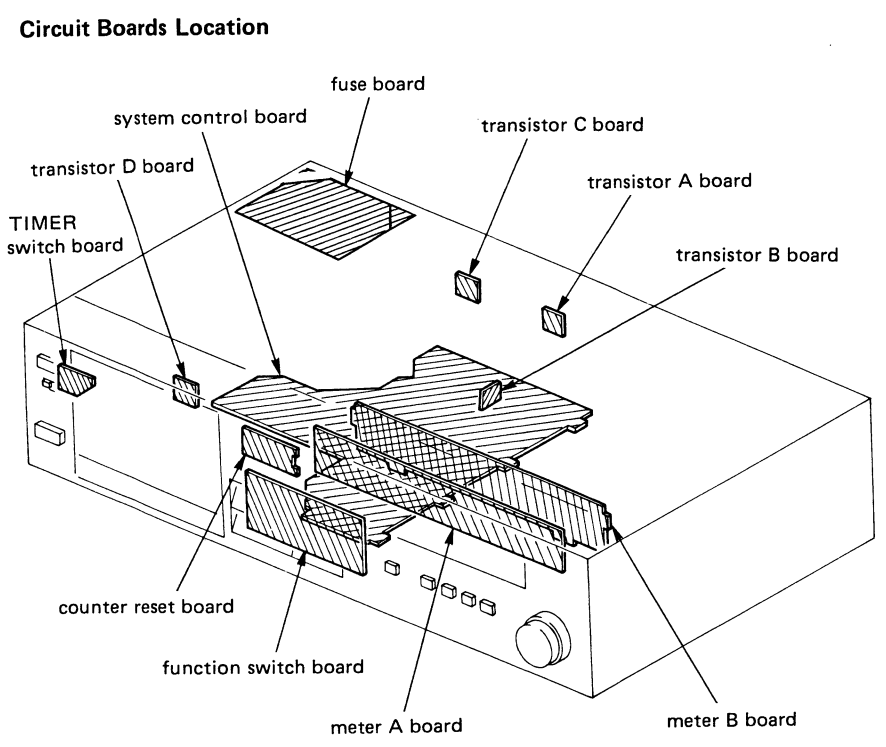

TAPE COUNTER

DP LIGHTING	0.9V
DP AND "-" (MINUS) LIGHTING	1.7V
DP "-" (MINUS) AND MEMORY LIGHTING	2.5V

TAPE COUNTER

DP LIGHTING	0.9V
DP AND "-" (MINUS) LIGHTING	1.7V
DP "-" (MINUS) AND MEMORY LIGHTING	2.5V

Note:  
 ● ○ : parts extracted from the component side.  
 ● : B+ pattern  
 ○ : B- pattern







4-4. SYSTEM CONTROL/METER SECTION SCHEMATIC DIAGRAM  
(Refer to page 64 for notes.)

TC-K666ES TC-K666ES

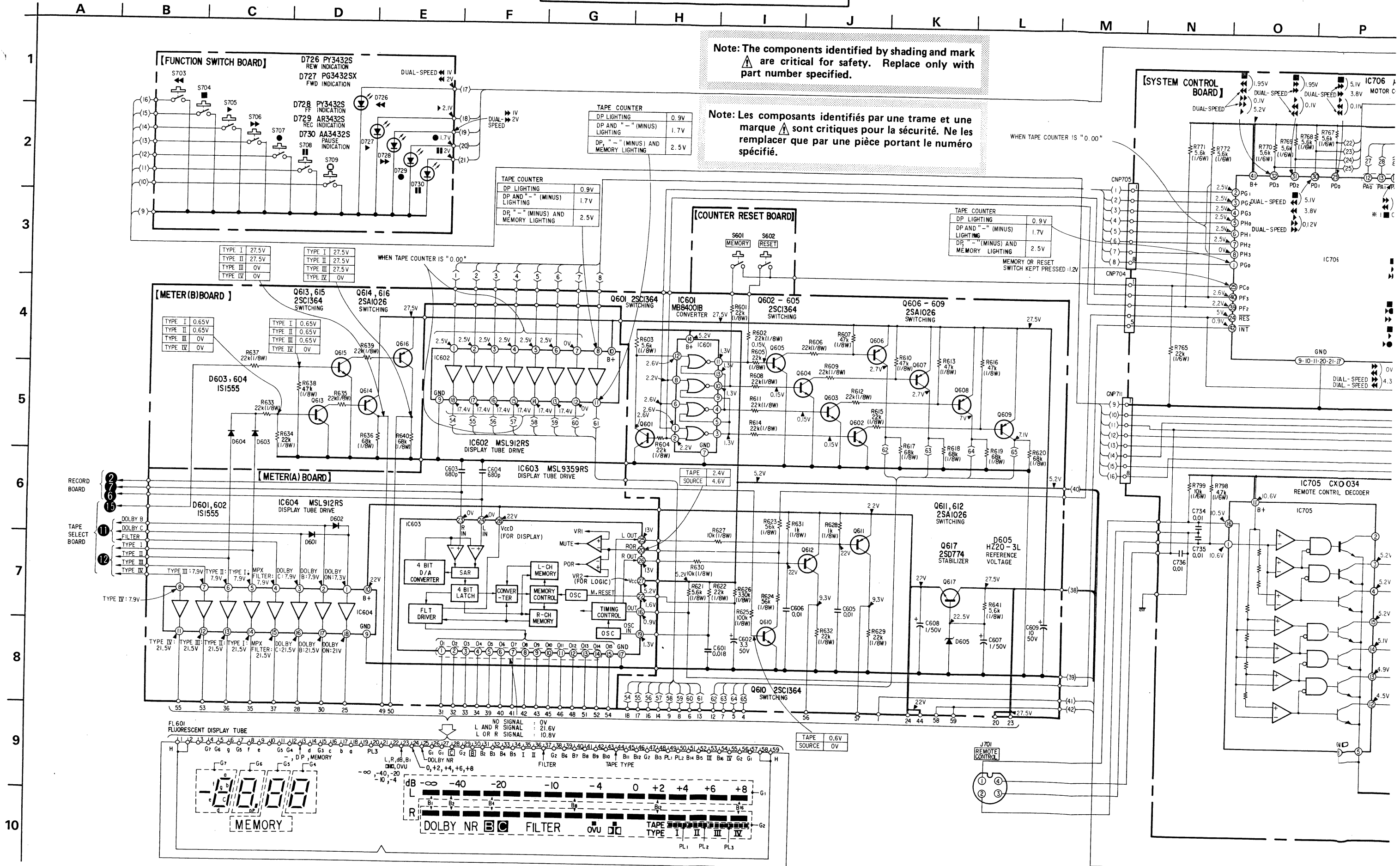

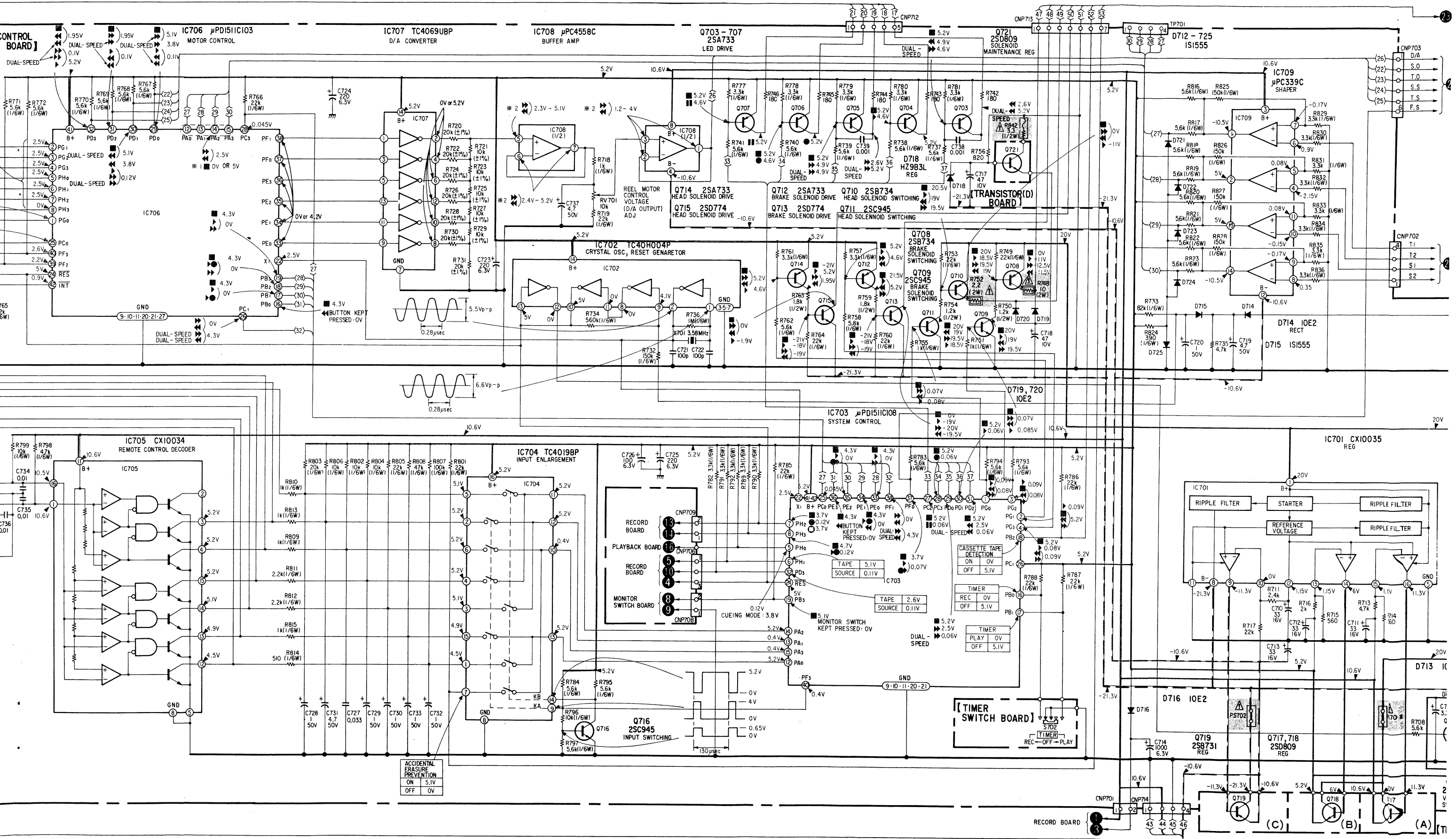

ACCIDENTAL ERASURE PREVENTION  
ON 5.1V  
OFF 0V



T U V W X Y Z A1 B1 C1 D1 E1 F1 G1 H1 I1

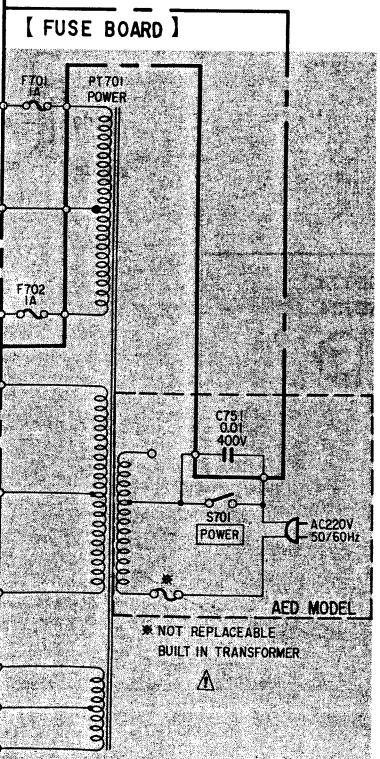
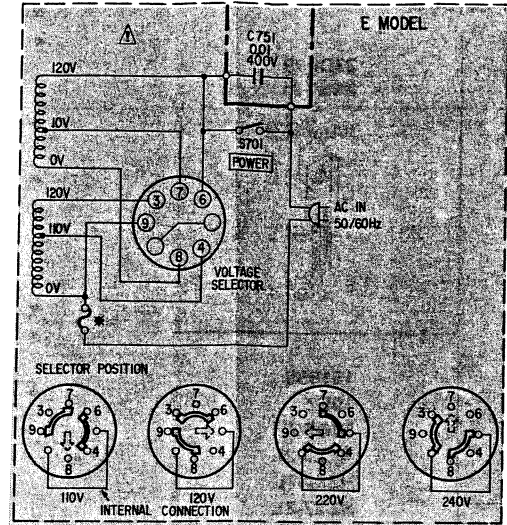
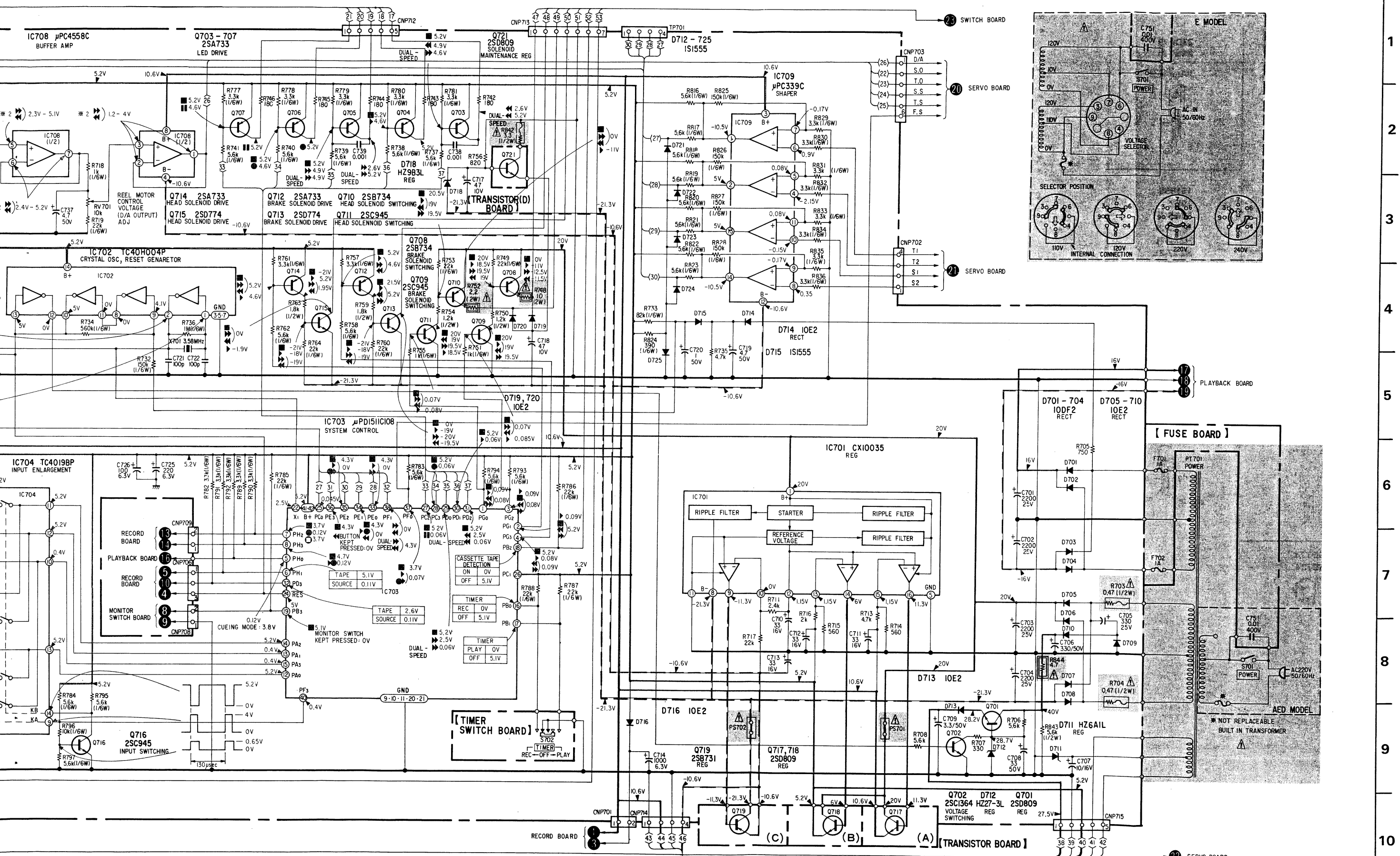

1  
2  
3  
4  
5  
6  
7  
8  
9  
10

Semiconductor Lead Layouts

MSL912RS  
MSL9359RS  
CX10034  
CX10035  
TC40H004P  
TC4019BP  
TC4069UBP  
μPC339C  
μPC4558C  
μPD1511C103  
μPD1511C108

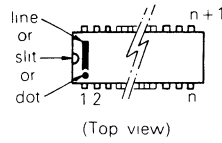

MB84001B

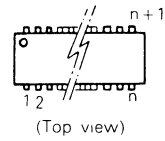

2SC1364



2SA1027R

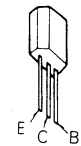

2SD774  
2SB734

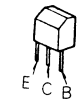

2SD809  
2SB731

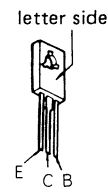

1S1555  
10E2  
10DF2  
HZ20-3L  
HZ6A1L  
HZ27-3L  
HZ9B3L

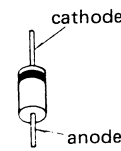

PY3432S  
PG3432S  
AA3432S  
AR3432S

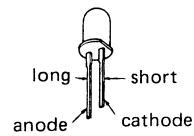

Note:

- All capacitors are in  $\mu\text{F}$  unless otherwise noted.  $\text{pF} : \mu\mu\text{F}$  50WV or less are not indicated except for electrolytics and tantalums.
- All resistors are in ohms,  $\frac{1}{4}\text{W}$  unless otherwise noted.  $\text{k}\Omega : 1000\Omega$ ,  $\text{M}\Omega : 1000\text{k}\Omega$
- : nonflammable resistor.
- : fusible resistor.
- : adjustment for repair.
- : B+ bus.
- : B- bus.
- Voltages are dc with respect to ground unless otherwise noted.
- Readings are taken under STOP mode.
  - : STOP
  - : FWD
  - : FF
  - : REW
  - : dual-speed REW
  - : REC
  - : REC MUTE
  - : PAUSE
- Voltage variations may be noted due to normal production tolerances.
  - \*1: Varied by the stop position of the reel motor.
  - \*2: Varied by the speed of the reel motor.
- Waveforms are taken with respect to ground at STOP mode.

Note: Voltages are measured with a VOM (50k $\Omega$ /V).

Circuit Boards Location

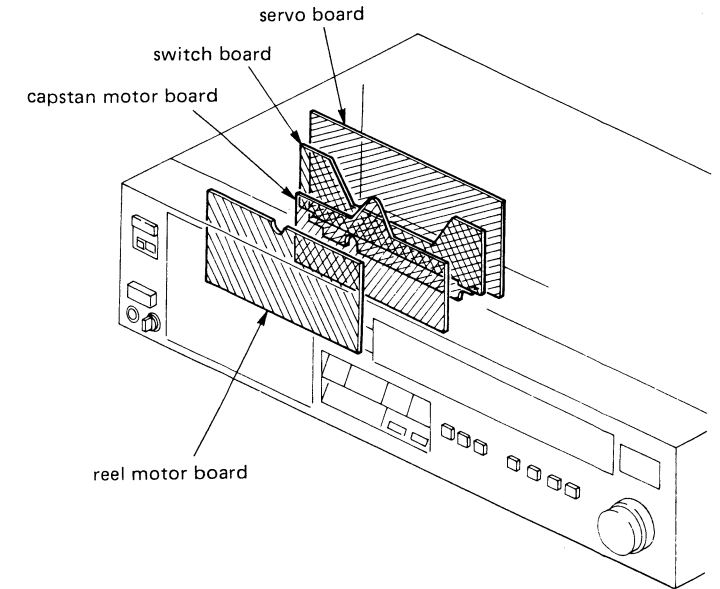

Semiconductor Lead

μPC4558C  
MSM58141RS

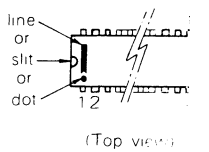

CX10031

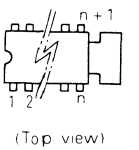

2SA1026-8

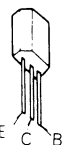

Note:

- : parts extracted from the component side.
- : parts extracted from the conductor side.
- : part mounted on the conductor side.
- : B + pattern
- : B - pattern

Circuit Boards Location

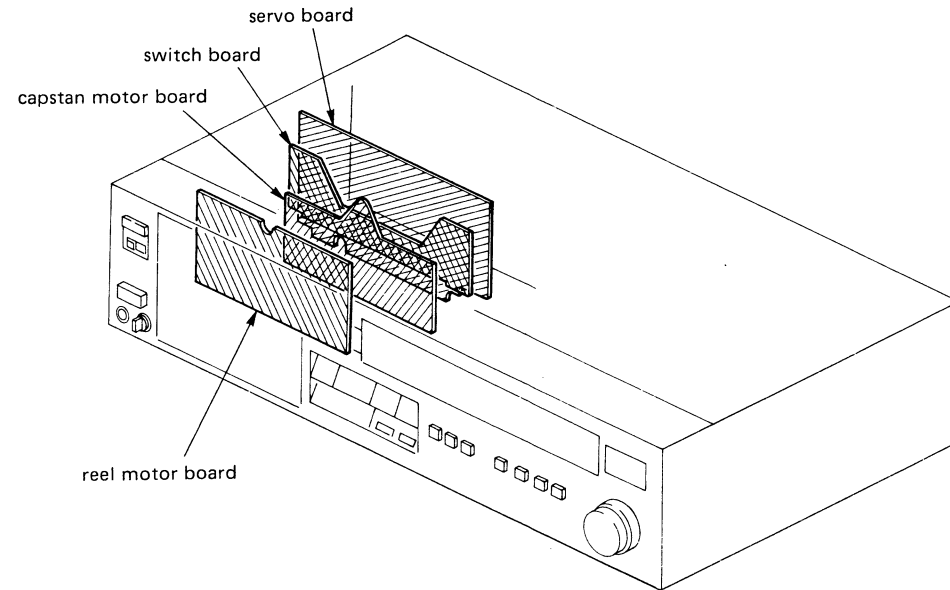

Semiconductor Lead Layouts

μPC4558C  
MSM58141RS

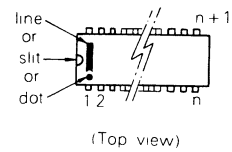

2SC1364 8

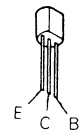

CX10031

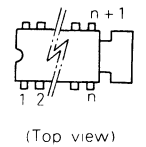

1S1555  
10E2

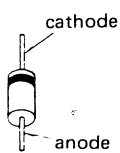

2SA1026-8

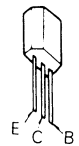

THS105

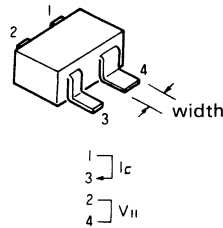

Note:

- — : parts extracted from the component side.
- — : parts extracted from the conductor side.
- : part mounted on the conductor side.
- ▨ : B + pattern
- ▩ : B - pattern

4-5. SERVO SECTION MOUNTING DIAGRAM

- Conductor Side -

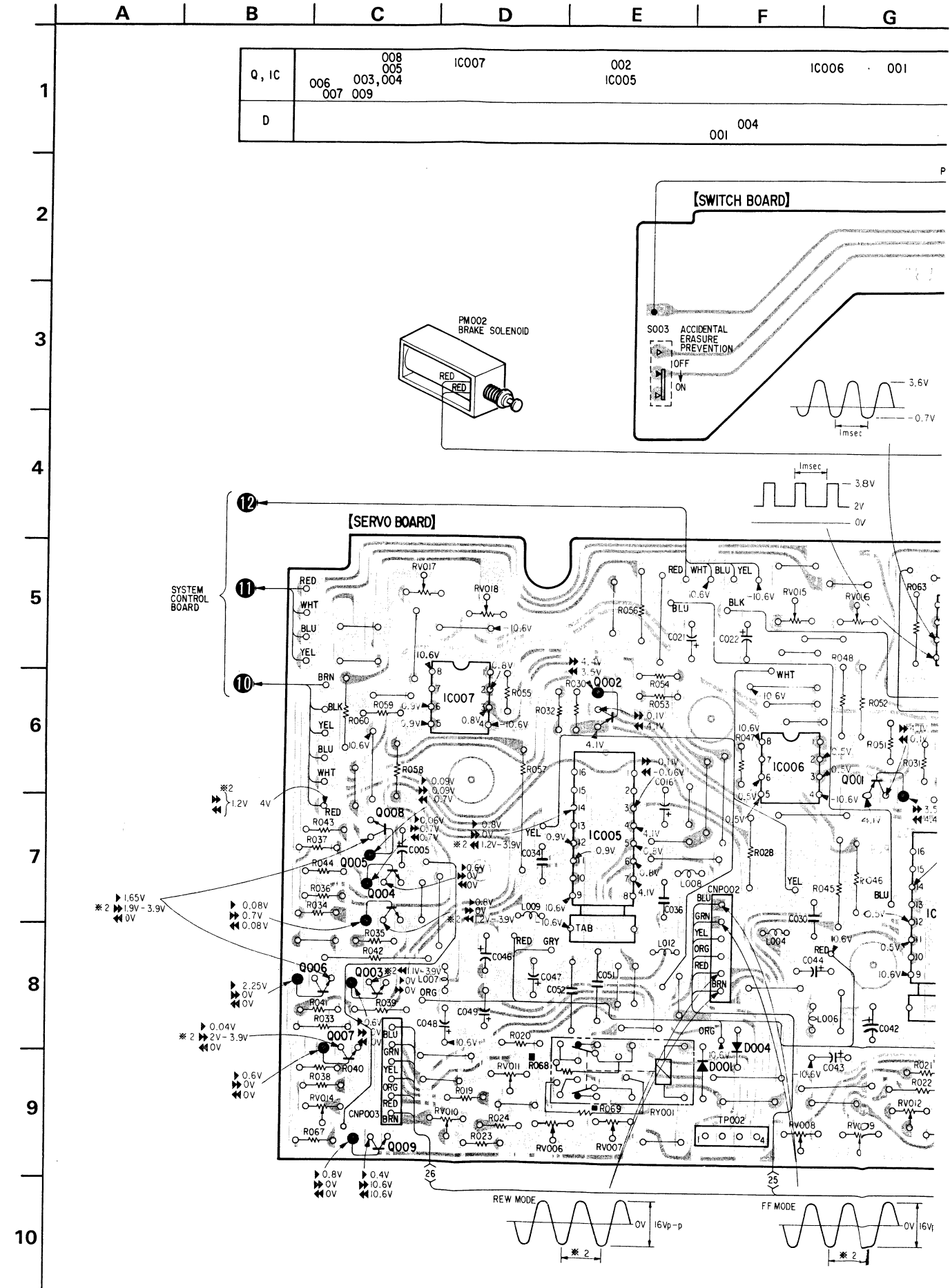

SERVO SECTION MOUNTING DIAGRAM

- Conductor Side -

A B C D E F G H I J K L M N O P

Q, IC	006 007	008 005 003,004 009	IC007	002 IC005	IC006	001	IC003 IC004	IC002	IC001	Q, IC
D				004 001					003,002	D

1  
2  
3  
4  
5  
6  
7  
8  
9  
10

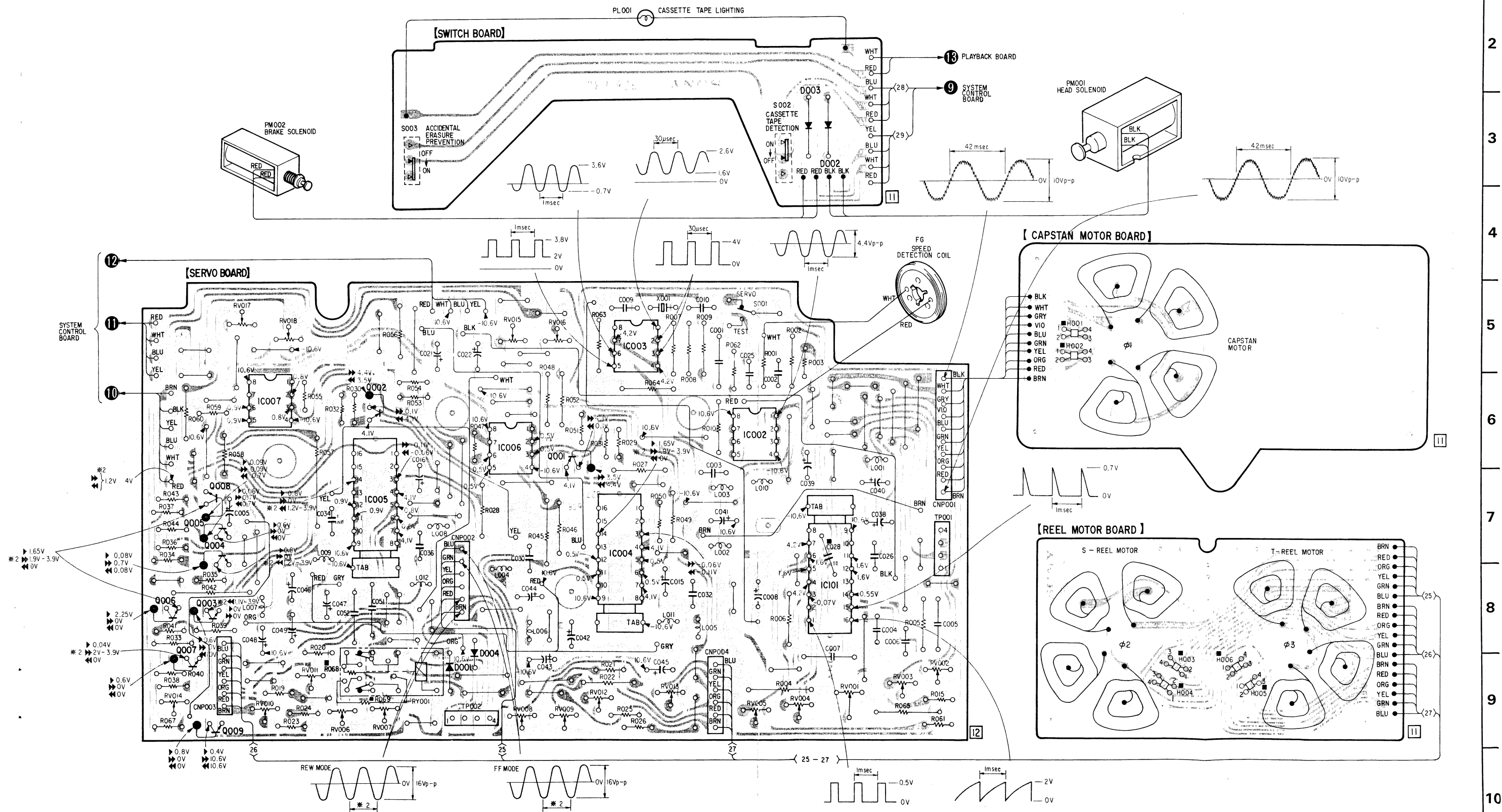





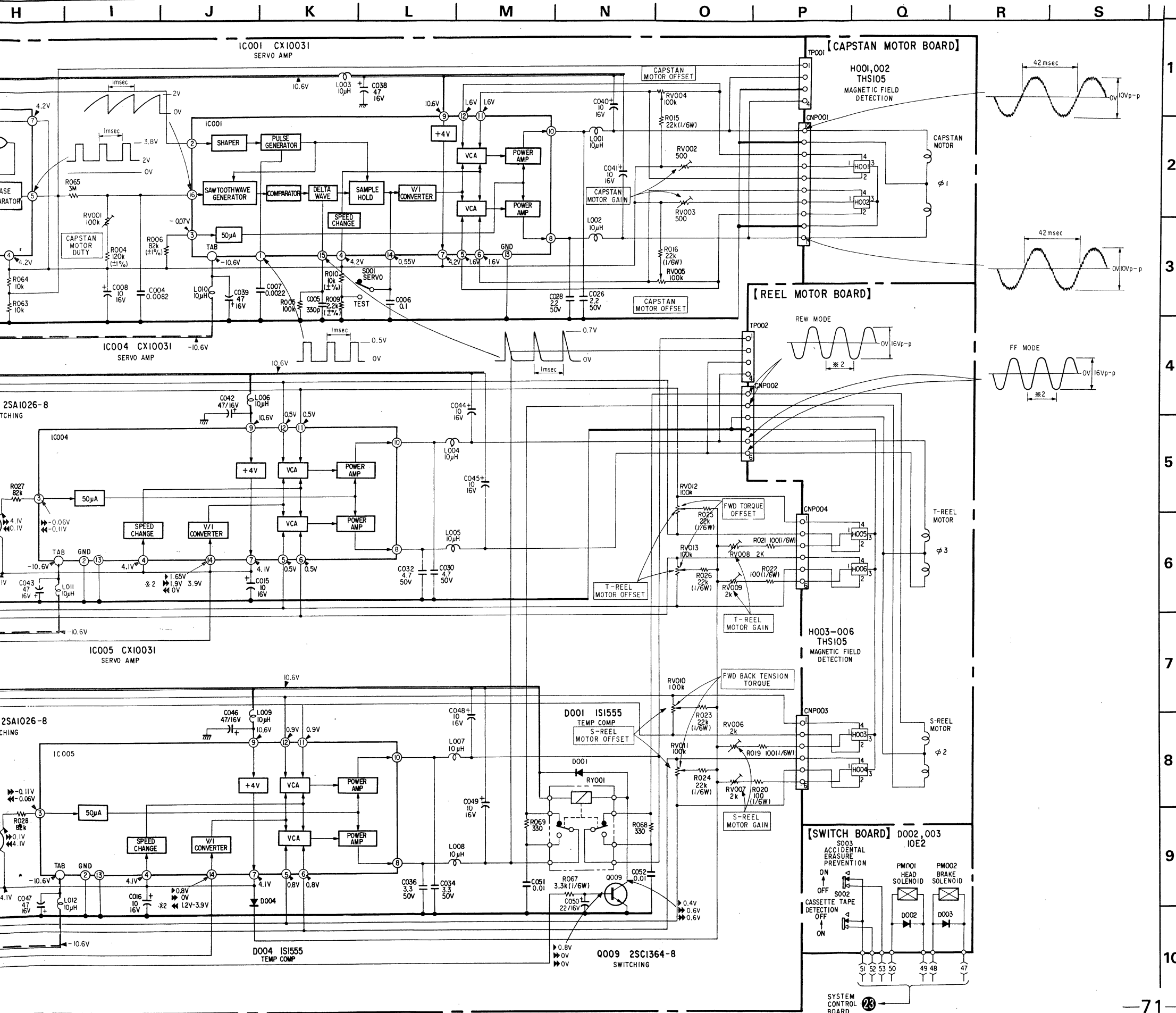

**Note:**

- All capacitors are in  $\mu\text{F}$  unless otherwise noted.  $\text{pF}$  :  $\mu\text{pF}$  50WV or less are not indicated except for electrolytics and tantalums.
- All resistors are in ohms,  $\frac{1}{4}\text{W}$  unless otherwise noted.  $\text{k}\Omega$  : 1000  $\Omega$ ,  $\text{M}\Omega$  : 1000  $\text{k}\Omega$
- $\square$  : adjustment for repair.
- $\text{---}$  : B+ bus.
- $\text{---}$  : B- bus.
- Voltages are dc with respect to ground unless otherwise noted.
- Readings are taken under STOP mode.
  - : STOP
  - ▶ : FWD
  - ▶▶ : FF
  - ▶▶▶ : dual-speed FF
  - ◀◀ : REW
  - ◀◀◀ : dual-speed REW
  - : REC
  - : REC
  - : REC MUTE
  - || : PAUSE
- Voltage variations may be noted due to normal production tolerances.
- \*2: Varied by the speed of the reel motor.
- Waveforms are taken with respect to ground at STOP mode.

Note: Voltages are measured with a VOM (50kΩ/V).

SECTION 5  
EXPLODED VIEWS AND PARTS LIST

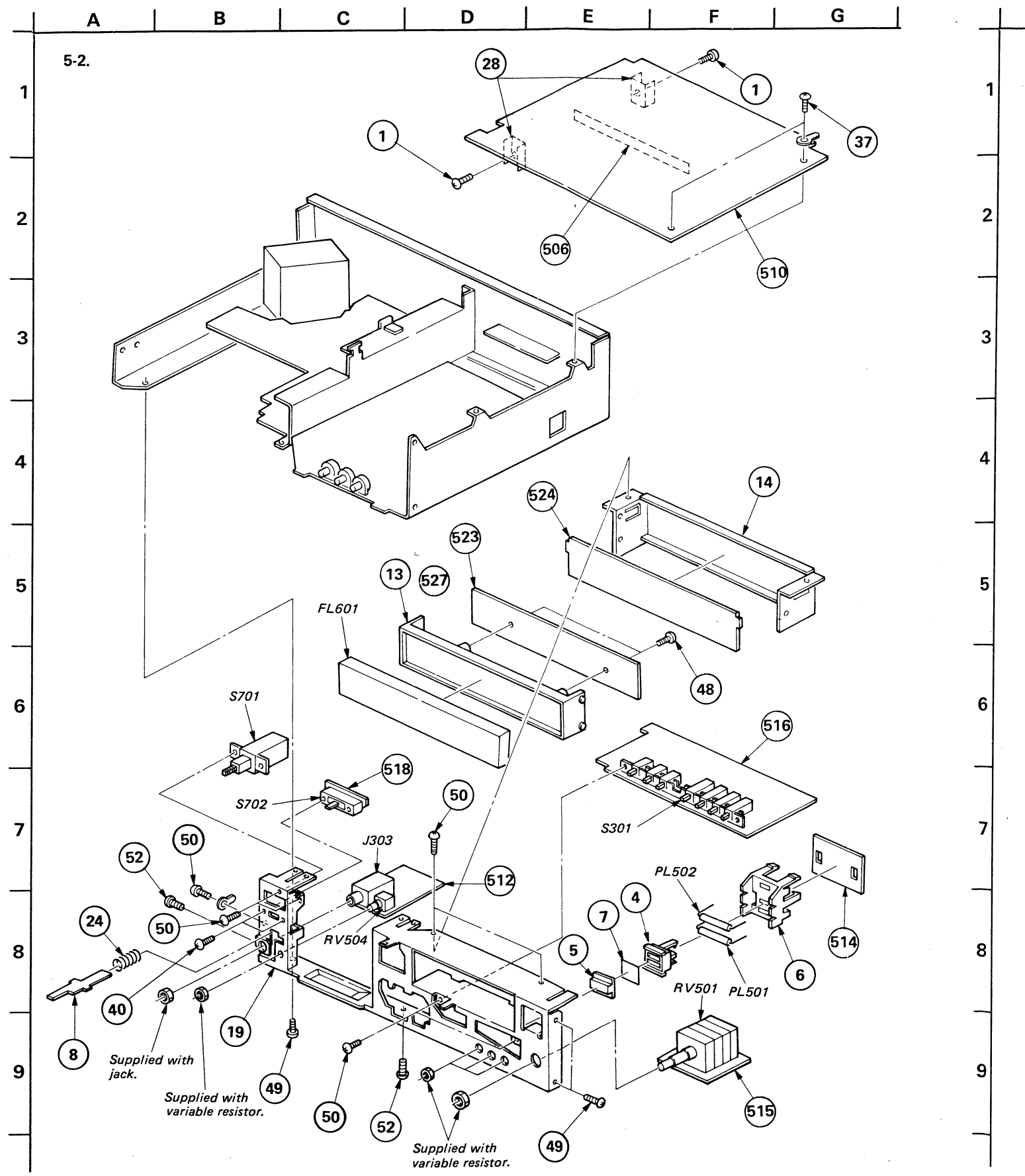
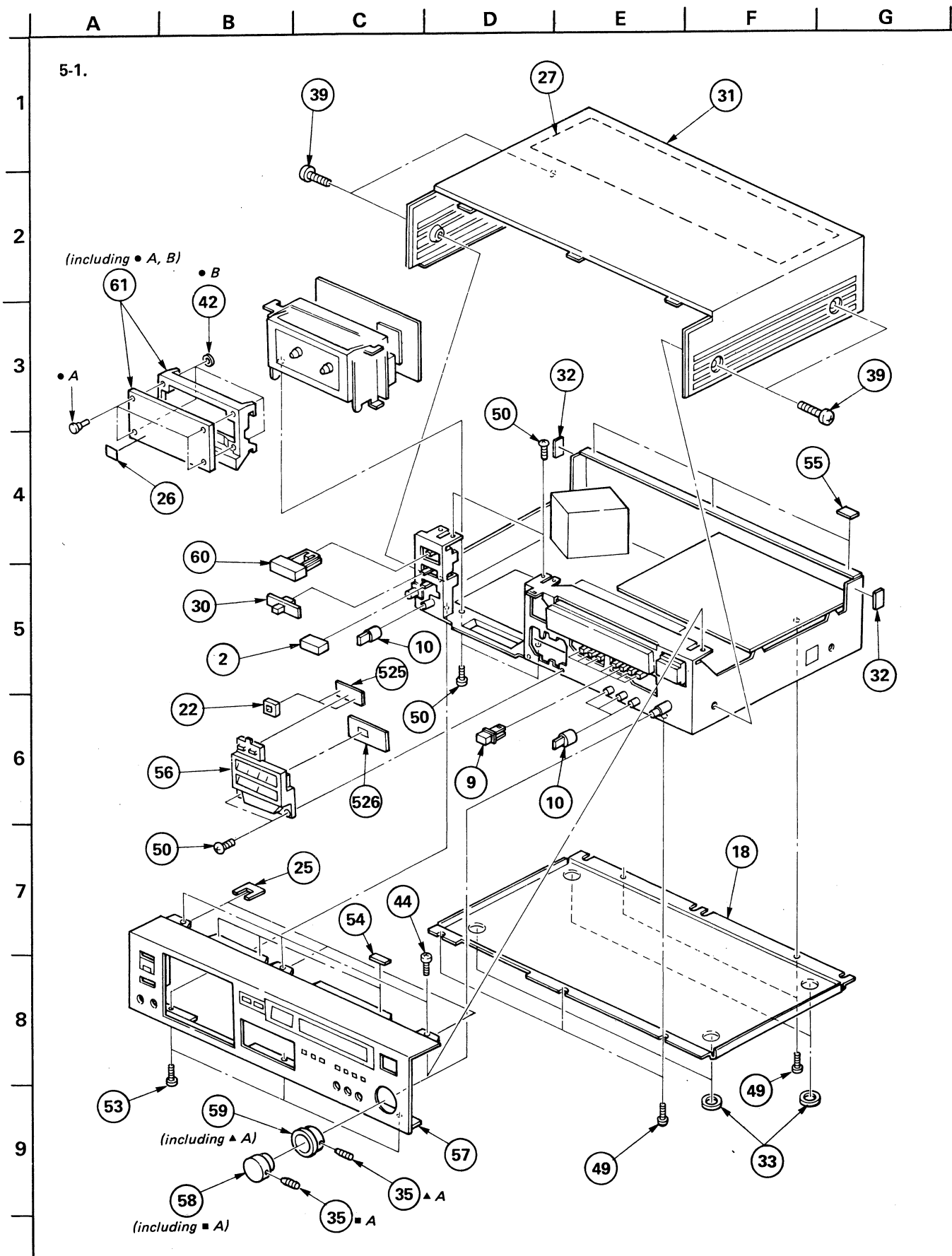

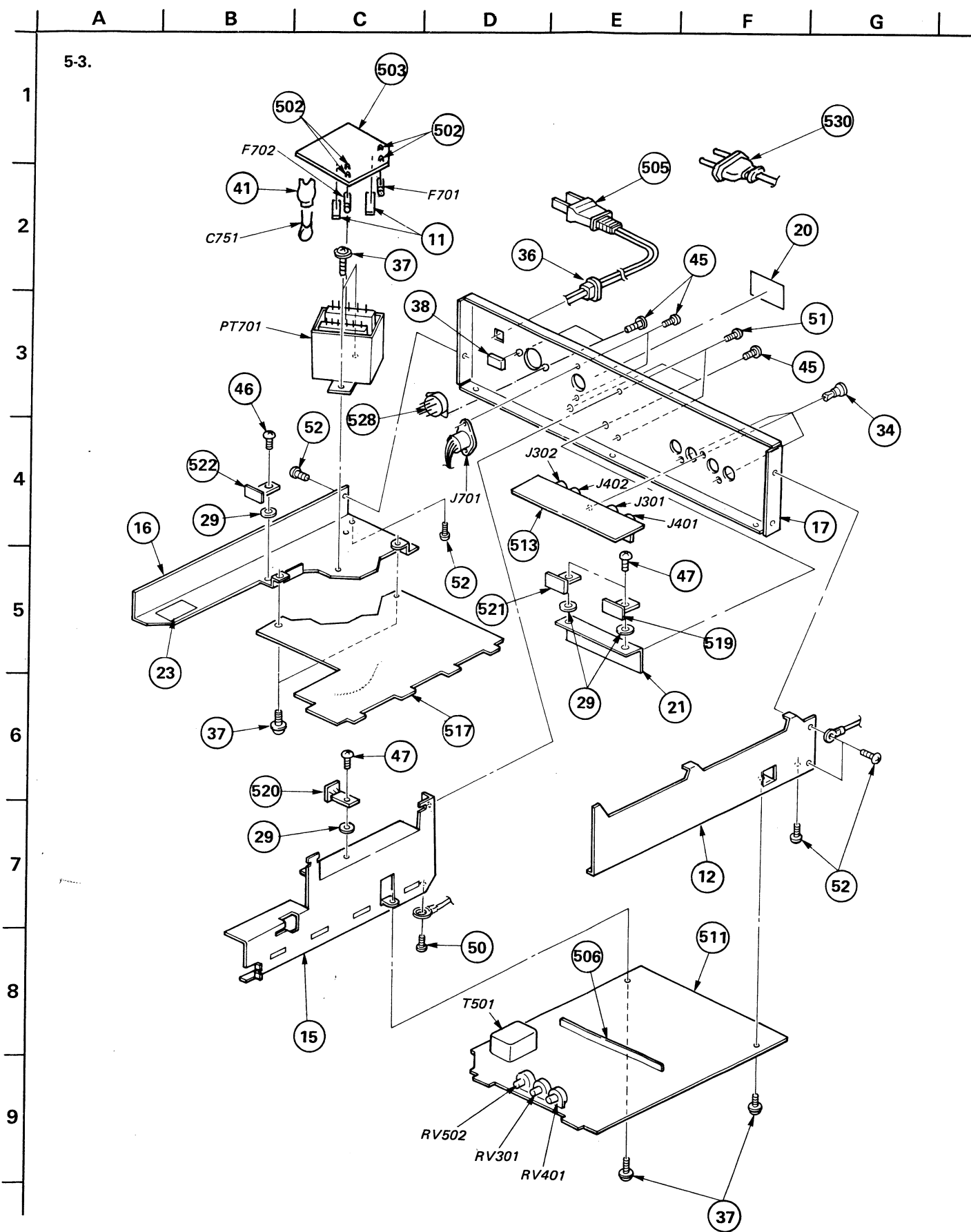
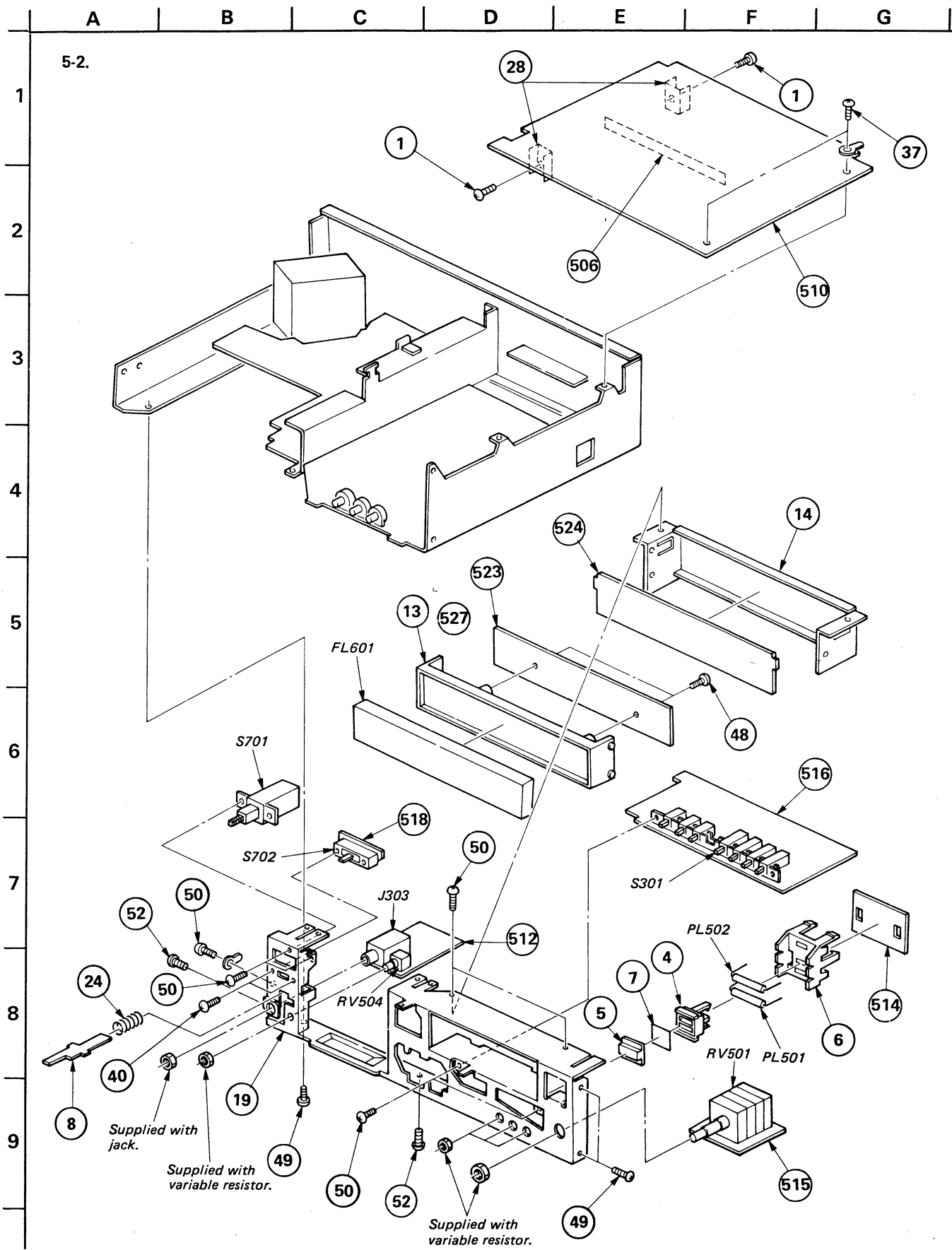



5-4.

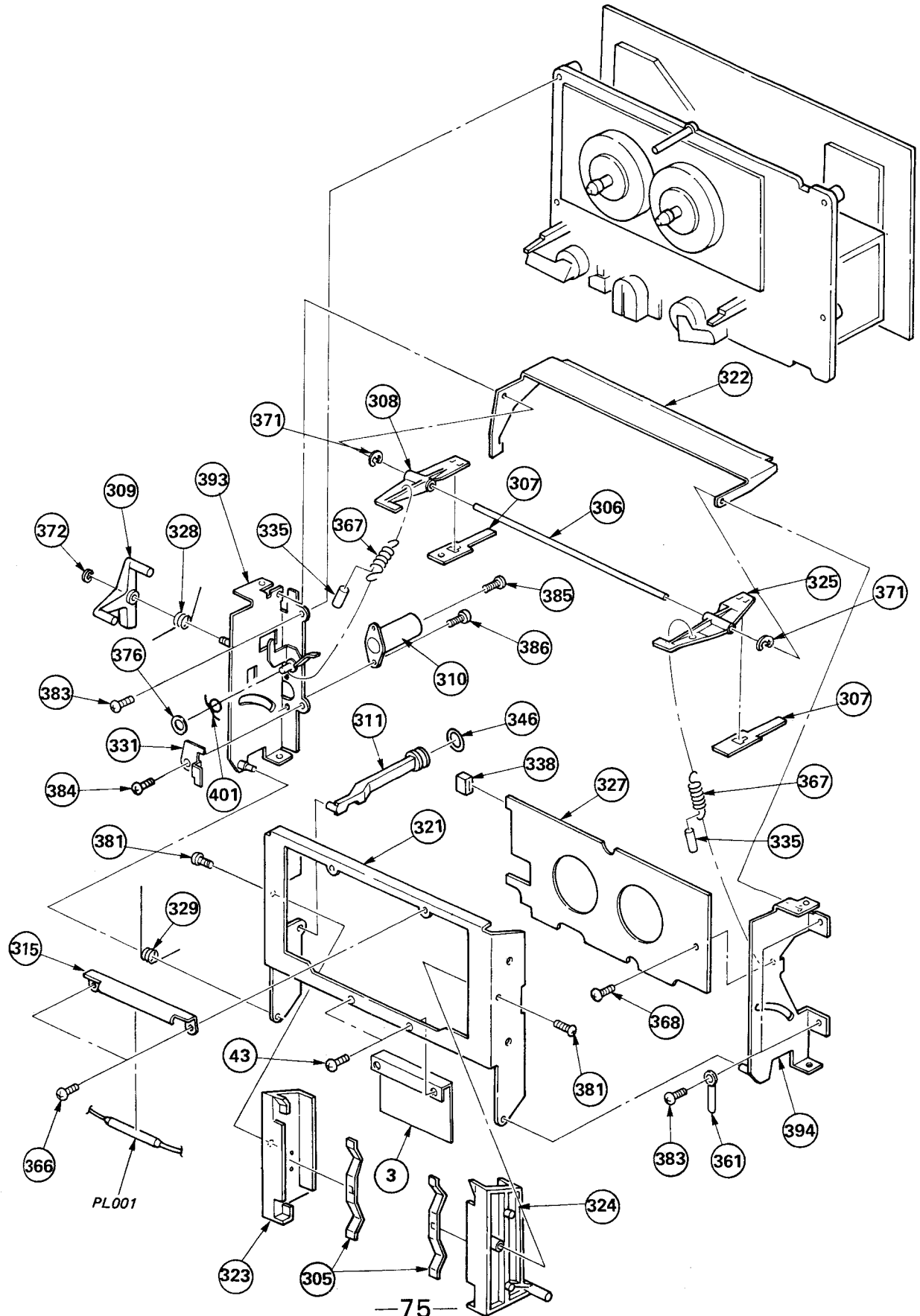

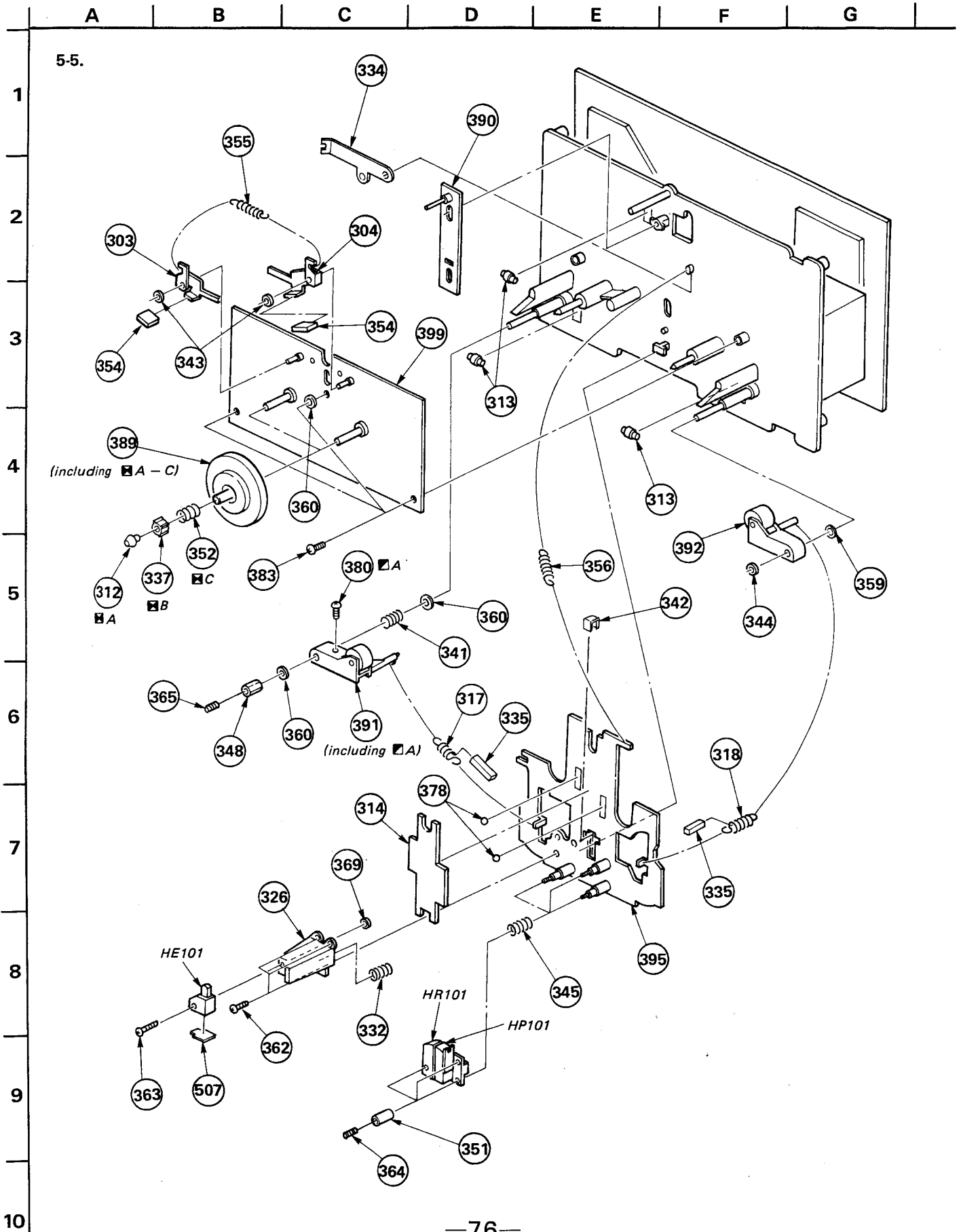

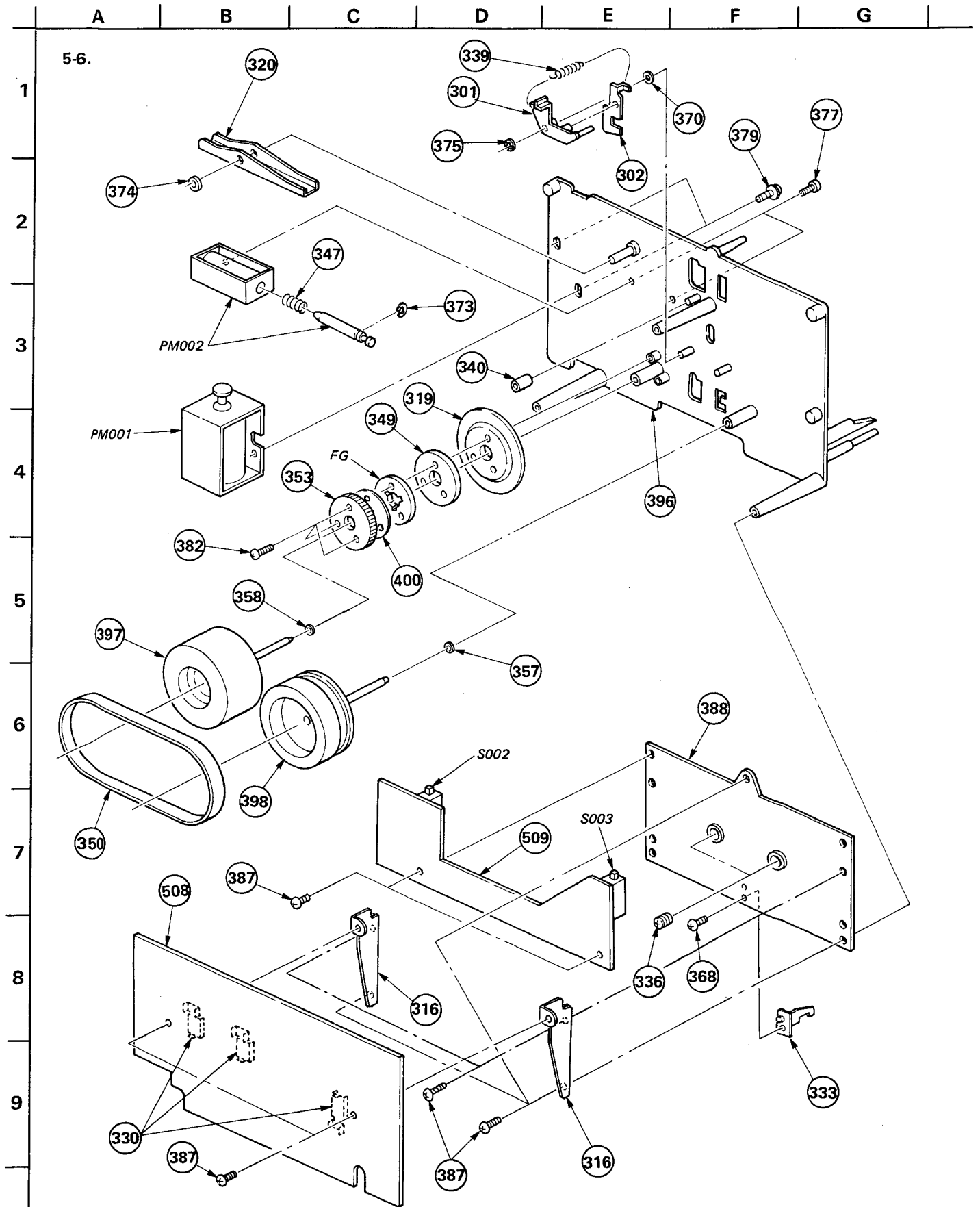

## GENERAL SECTION

No.	Part No.	Description
1	2-259-121-00	SCREW, TR
2	3-304-419-31	BUTTON, EJECT
3	♣;3-310-823-00	PLATE, SHIELD, HEAD
4	♣;3-311-501-00	HOLDER, MONITOR SWITCH
5	3-311-502-00	WINDOW, MONITOR SWITCH
6	3-311-504-00	RETAINER, LAMP, MONITOR
7	♣;3-311-505-00	ILLUMINATOR
8	♣;3-311-508-00	SLIDER, EJECT
9	3-311-509-00	PUSH BUTTON
10	3-311-513-00	KNOB, CALIBRATION
11	♣;3-701-948-14	LABEL, FUSE
12	♣;3-311-529-00	PLATE, SIDE, RIGHT
13	♣;3-311-532-00	HOLDER, FL TUBE
14	♣;3-311-533-00	CASE, SHIELD, FL TUBE
15	♣;3-311-535-00	PLATE, RELAY
16	♣;3-311-536-00	PLATE, SIDE, LEFT
17	♣;3-311-537-21	(AEP)...PLATE, JACK
17	♣;3-311-537-33	(E).....PLATE, JACK
18	♣;3-311-541-00	PLATE, BOTTOM
19	♣;3-311-542-00	CHASSIS, FRONT
20	3-311-555-00	(AEP).....LABEL, MODEL NUMBER
20	3-311-556-00	(E).....LABEL, MODEL NUMBER
20	3-311-559-00	(G-AEP)...LABEL, MODEL NUMBER
21	♣;3-311-545-00	HEAT SINK
22	3-311-546-00	CUSHION, SWITCH, MONITOR
23	3-311-547-00	SHEET, INSULATING
24	3-543-966-00	SPRING, COMPRESSION
25	3-544-028-01	SPACER, PANEL (T=0.3)
25	3-544-028-11	SPACER, PANEL (T=0.5)
25	3-544-028-21	SPACER, PANEL (T=1)
26	3-703-710-41	STICKER, SONY SYMBOL (GOLD)
27	3-831-441-XX	SHEET (T=0.5)
28	♣;3-567-242-00	HEAT SINK
29	3-572-365-01	SHEET (A), INSULATING
30	3-575-515-41	KNOB, SLIDE SWITCH
31	3-575-539-51	CASE
32	9-911-841-XX	RUBBER, PROTECTION (T=5)
33	3-576-731-00	FELT (H)
34	3-646-090-11	RIVET, NYLON
35	3-701-506-01	SET SCREW, DOUBLE POINT 3X4
36	3-703-244-00	BUSHING, CORD
37	3-703-486-01	SCREW +PTTWH 3X5
38	9-911-840-XX	CUSHION, RUBBER (T=3)
39	4-820-330-31	SCREW, BW, PLUS MINUS
40	7-621-775-10	SCREW +B 2.6X4

### NOTE:

- Items with no part number and no description are not stocked because they are seldom required for routine service.
- Items marked "♣" are not stocked since they are seldom required for routine service. Some delay should be anticipated when ordering these items.
- Due to standardization, parts with part numbers (Δ-ΔΔΔ-ΔΔΔ-XX or Δ-ΔΔΔΔ-ΔΔΔ-X) may be different from those used in the set.
- If there are two or more same circuits in a set such as a stereophonic machine, only typical circuit parts may be indicated and capacitors and resistors in other same circuits may be omitted.

### CAPACITORS:

MF:μF, PF:μμF.

### RESISTORS

- All resistors are in ohms.
- F: nonflammable

### COILS

MMH: mH, UH: μH

### SEMICONDUCTORS

In each case, U: μ, for example:  
 UA...: μA..., UPA...: μPA..., UPC...: μPC,  
 UPD...: μPD...

## GENERAL SECTION

No.	Part No.	Description
41	4-875-455-21	COVER (DIA. 20), CAPACITOR
42	7-624-190-11	STOP RING 3, TYPE-CS
43	7-627-452-28	SCREW, PRECISION +K 2X4
44	7-682-247-04	SCREW +K 3X6
45	7-682-547-09	SCREW +B 3X6
46	7-682-947-01	SCREW +PSW 3X6
47	7-682-948-01	SCREW +PSW 3X8
48	7-685-545-19	SCREW +BTP 3X6 TYPE2 N-S
49	7-685-870-01	SCREW +BVTT 3X5 (S)
50	7-685-871-01	SCREW +BVTT 3X6 (S)
51	7-685-871-09	SCREW +BVTT 3X6 (S)
52	7-685-872-01	SCREW +BVTT 3X8 (S)
53	7-687-712-39	SCREW BTT 3X6
54	9-911-837-XX	CUSHION (A), FILTER (T=1)
55	9-911-837-XX	CUSHION, FILTER (T=1)
56	X-3311-505-1	BUTTON ASSY, CONTROL
57	X-3311-504-0	PANEL ASSY, FRONT
58	X-3304-909-0	KNOB (RIGHT) ASSY, REC
59	X-3304-910-0	KNOB (LEFT) ASSY, REC
60	X-3304-911-0	KNOB ASSY, POWER
61	X-3311-503-0	WINDOW ASSY, CASSETTE

## ACCESSORY & PACKING MATERIAL

Part No.	Description
1-551-734-11	CORD, CONNECTION (RK- 74A)
2-259-253-00	BAG, PROTECTION (FOR SET)
3-311-550-00	CUSHION (LEFT), UPPER
3-311-551-00	CUSHION (RIGHT), UPPER
3-311-552-00	CUSHION (LEFT), LOWER
3-311-553-00	CUSHION (RIGHT), LOWER
3-311-554-00	INDIVIDUAL CARTON
3-701-630-00	BAG, POLYETHYLENE (FOR INSTRUCTION MANUAL)
3-703-330-01	LABEL, SEAL
3-773-240-11	(E).....MANUAL, INSTRUCTION
3-773-240-41	(AEP)...MANUAL, INSTRUCTION
3-793-481-13	INSTRUCTION
3-793-828-11	QUESTIONNAIRE
X-3701-105-0	ROD ASSY, CLEANING, HEAD

The components identified by shading and mark  are critical for safety. Replace only with part number specified.

## MECHANISM SECTION

No.	Part No.	Description
301	3-310-801-00	LEVER (A), PAUSE
302	3-310-802-00	LEVER (B), PAUSE
303	3-310-807-00	BRAKE (LEFT)
304	3-310-808-00	BRAKE (RIGHT)
305	3-310-809-00	SPRING
306	▲;3-310-810-00	SHAFT, DETECTION LEVER
307	3-310-811-00	SPRING
308	3-310-812-00	LEVER (L), REC DETECTION
309	3-310-813-00	LEVER, EJECT
310	3-310-815-00	CYLINDER
311	3-310-816-00	PISTON
312	3-310-817-00	BUSHING, REEL TABLE
313	3-310-820-00	ROLLER, HEAD BASE
314	▲;3-310-821-00	SPRING
315	3-310-824-00	HOLDER, LAMP
316	▲;3-310-827-00	BRACKET, PC BOARD
317	3-310-829-00	SPRING, COMPRESSION
318	3-310-830-00	SPRING, COMPRESSION
319	▲;3-310-831-01	PLATE, SHIELD, MOTOR
320	▲;3-310-834-00	LEVER, FWD
321	3-310-843-00	HOLDER, CASSETTE
322	▲;3-310-844-00	PLATE, RELEASE
323	3-310-845-00	GUIDE (LEFT), HOLDER
324	3-310-846-00	GUIDE (RIGHT), HOLDER
325	3-310-847-00	LEVER, HALF DETECTION
326	▲;3-310-852-00	BRACKET, E HEAD
327	3-310-855-00	PLATE, ORNAMENTAL, CASSETTE
328	3-310-856-00	SPRING
329	3-310-857-00	SPRING
330	▲;3-310-859-00	HEAT SINK, IC
331	▲;3-310-860-01	RETAINER, HEAD CHASSIS
332	3-310-861-00	SPRING, COMPRESSION
333	▲;3-310-862-00	PLATE, PREVENTION
334	▲;3-310-863-00	LEVER, EB
335	9-911-815-02	CUSHION (T=5)
336	3-489-073-21	SCREW, THRUST
337	3-531-760-00	CLAW, REEL SPINDLE
338	3-531-766-00	RUBBER, BRAKE
339	3-534-027-00	SPRING, TENSION
340	3-537-173-00	CUSHION, CASSETTE-UP
341	3-537-213-00	SPRING, COMPRESSION
342	3-310-864-00	STOPPER, H.B
343	3-558-708-01	WASHER, STOPPER
344	3-558-708-21	WASHER, STOPPER
345	3-564-121-00	SPRING, COMPRESSION

## MECHANISM SECTION

No.	Part No.	Description
346	3-575-392-00	RING, PISTON
347	3-575-414-00	SPRING, COMPRESSION
348	3-576-808-00	ADJUSTOR, PINCH ROLLER
349	▲;3-576-810-00	PLATE, RETURN CIRCUIT
350	3-576-812-00	BELT, CAPSTAN
351	3-576-834-00	NUT, LOCK
352	3-576-921-00	SPRING, COMPRESSION
353	▲;3-576-961-11	PLATE, FG
354	3-579-008-00	RUBBER, BRAKE
355	3-583-540-00	SPRING, TENSION
356	3-642-491-00	SPRING, TENSION
357	3-701-438-01	WASHER
358	3-701-438-31	WASHER
359	3-701-439-11	WASHER
360	3-701-439-21	WASHER
361	3-701-822-00	STOPPER, LEAD WIRE
362	7-621-255-35	SCREW +P 2X5
363	7-621-256-05	SCREW +P 2X16
364	7-621-732-08	SET-SCT, HEX. 2X3 FLAT POINT
365	7-621-737-08	SET-SCT, HEX. 2.6X3, FLAT POINT
366	7-621-772-00	SCREW +B 2X3
367	3-140-235-XX	SPRING, TENSION
368	7-621-775-20	SCREW +B 2.6X5
369	7-622-205-05	N 2, TYPE 2
370	3-701-439-01	WASHER
371	7-624-104-04	STOP RING 2.0, TYPE -E
372	7-624-106-04	STOP RING 3.0, TYPE -E
373	7-624-108-04	STOP RING 4.0, TYPE -E
374	7-624-190-11	STOP RING 3, TYPE-CS
375	7-624-190-81	STOP RING 2, TYPE-CS
376	7-624-190-31	STOP RING 4, TYPE-ES
377	7-628-254-15	SCREW +PS 2.6X6
378	7-671-112-11	BALL, STEEL
379	7-682-948-01	SCREW +PSW 3X8
380	7-685-203-14	SCREW +KTP 2X5 TYPE2 NON-SLIT
381	7-685-532-19	SCREW +BTP 2.6X5 TYPE2 N-S
382	7-685-535-19	SCREW +BTP 2.6X10 TYPE2 N-S
383	7-685-645-71	SCREW +BVTP 3X6 TYPE2 SLIT
384	7-685-646-71	SCREW +BVTP 3X8 TYPE2 SLIT
385	7-685-860-01	SCREW +BVTT 2.6X4 (S)
386	7-685-861-01	SCREW +BVTT 2.6X5 (S)
387	7-685-871-01	SCREW +BVTT 3X6 (S)
388	A-2109-008-A	RETAINER COMPLETE ASSY, THRUST
389	A-2130-015-A	ROTOR COMPLETE ASSY, REEL
390	X-3310-801-0	LEVER ASSY, BRAKE

### NOTE:

- Items with no part number and no description are not stocked because they are seldom required for routine service.
- Items marked "▲" are not stocked since they are seldom required for routine service. Some delay should be anticipated when ordering these items.
- Due to standardization, parts with part numbers (Δ-ΔΔΔ-ΔΔΔ-XX or Δ-ΔΔΔΔ-ΔΔΔ-X) may be different from those used in the set.
- If there are two or more same circuits in a set such as a stereophonic machine, only typical circuit parts may be indicated and capacitors and resistors in other same circuits may be omitted.

### CAPACITORS:

MF:μF, PF:μμF.

### RESISTORS

All resistors are in ohms.

F : nonflammable

### COILS

MMH : mH, UH : μH

### SEMICONDUCTORS

In each case, U : μ, for example:

UA...: μA..., UPA...: μPA..., UPC...: μPC,

UPD...: μPD...

The components identified by shading and mark ▲ are critical for safety. Replace only with part number specified.

## MECHANISM SECTION

No.	Part No.	Description
391	X-3310-805-0	PINCH ROLLER (S) ASSY
392	X-3310-806-0	PINCH ROLLER (T) ASSY
393	♣;X-3310-807-0	PLATE (L) ASSY, FULCRUM, HOLDER
394	♣;X-3310-808-0	PLATE (R) ASSY, FULCRUM, HOLDER
395	X-3310-809-0	CHASSIS ASSY, HEAD
396	♣;X-3310-810-0	CHASSIS ASSY, MECHANICAL
397	X-3310-811-0	FLYWHEEL (T) ASSY
398	X-3310-812-0	FLYWHEEL (S) ASSY
399	X-3310-802-0	CHASSIS ASSY, REEL
400	3-310-865-00	WASHER, INSULATING
401	3-310-866-00	SPRING

## ELECTRICAL PARTS

Ref.No.	Part No.	Description
501	♣;1-508-801-00	U TYPE BASE POST 4P
502	♣;1-533-131-00	HOLDER, FUSE
503	♣;1-609-889-00	PC BOARD, FUSE
504	♣;1-535-116-00	TERMINAL
505	♣;1-556-091-00	(E2)...CORD, POWER
506	♣;1-560-242-51	BUS BAR 7P
507	♣;1-608-268-00	PC BOARD, ERASE HEAD
508	♣;1-608-827-00	PC BOARD, SERVO
508	♣;A-2020-075-A	MOUNTED PCB, SERVO
509	♣;1-608-830-00	PC BOARD, SWITCH
510	♣;1-608-922-00	PC BOARD, PLAYBACK
510	♣;A-2056-185-A	MOUNTED PCB, PLAYBACK
511	♣;1-608-923-00	PC BOARD, RECORD
511	♣;A-2056-183-A	MOUNTED PCB, RECORD
512	♣;1-608-924-00	PC BOARD, HEADPHONE
513	♣;1-608-925-00	PC BOARD, PIN JACK
514	♣;1-608-926-00	PC BOARD, MONITER SW
515	♣;1-608-927-00	PC BOARD, REC VOL
516	♣;1-608-928-00	PC BOARD, TAPE SELECT
517	♣;1-608-929-00	PC BOARD, SYSTEM CONTROL
517	♣;A-2056-184-A	MOUNTED PCB, SYSTEM CONTROL
518	♣;1-608-930-00	PC BOARD, TIMER SW
519	♣;1-608-931-00	PC BOARD, TRANSISTOR A
520	♣;1-608-932-00	PC BOARD, TRANSISTOR B
521	♣;1-608-933-00	PC BOARD, TRANSISTOR C
522	♣;1-608-934-00	PC BOARD, TRANSISTOR D
523	♣;1-608-935-00	PC BOARD, METER A

## ELECTRICAL PARTS

Ref.No.	Part No.	Description				
524	♣;1-608-936-00	PC BOARD, METER B				
525	♣;1-608-937-00	PC BOARD, COUNTER RESET				
526	♣;1-608-938-00	PC BOARD, CONTROL SWITCH				
527	♣;A-2056-182-A	MOUNTED PCB, METER				
528	♣;1-526-576-31	(E)...SELECTOR, POWER VOLTAGE				
529	♣;1-535-303-00	WIRE, JUMPER				
530	♣;1-555-795-00	(AEP,E1)...CORD, POWER				
C001	1-161-375-00	CERAMIC	0.0022MF	20%	50V	
C002	1-130-634-00	FILM	0.15MF	5%	50V	
C003	1-130-620-00	FILM	0.01MF	5%	50V	
C004	1-129-029-00	FILM	0.0082MF	5%	50V	
C005	1-161-317-00	CERAMIC	330PF	10%	50V	
C006	1-130-632-00	FILM	0.1MF	5%	50V	
C007	1-161-375-00	CERAMIC	0.0022MF	20%	50V	
C008	1-123-356-00	ELECT	10MF	20%	16V	
C009	1-102-851-00	CERAMIC	15PF	5%	50V	
C010	1-102-851-00	CERAMIC	15PF	5%	50V	
C015	1-123-356-00	ELECT	10MF	20%	16V	
C016	1-123-356-00	ELECT	10MF	20%	16V	
C021	1-123-319-00	ELECT	47MF	20%	16V	
C022	1-123-319-00	ELECT	47MF	20%	16V	
C025	1-130-620-00	FILM	0.01MF	5%	50V	
C026	1-124-183-00	ELECT(NONPOLAR)	2.2MF	20%	50V	
C028	1-124-183-00	ELECT(NONPOLAR)	2.2MF	20%	50V	
C030	1-124-185-00	ELECT(NONPOLAR)	4.7MF	20%	50V	
C032	1-124-185-00	ELECT(NONPOLAR)	4.7MF	20%	50V	
C034	1-124-184-00	ELECT(NONPOLAR)	3.3MF	20%	50V	
C036	1-124-184-00	ELECT(NONPOLAR)	3.3MF	20%	50V	
C038	1-123-319-00	ELECT	47MF	20%	16V	
C039	1-123-319-00	ELECT	47MF	20%	16V	
C040	1-123-356-00	ELECT	10MF	20%	16V	
C041	1-123-356-00	ELECT	10MF	20%	16V	
C042	1-123-319-00	ELECT	47MF	20%	16V	
C043	1-123-319-00	ELECT	47MF	20%	16V	
C044	1-123-356-00	ELECT	10MF	20%	16V	
C045	1-123-356-00	ELECT	10MF	20%	16V	
C046	1-123-319-00	ELECT	47MF	20%	16V	
C047	1-123-319-00	ELECT	47MF	20%	16V	
C048	1-123-356-00	ELECT	10MF	20%	16V	
C049	1-123-356-00	ELECT	10MF	20%	16V	
C050	1-123-317-00	ELECT	22MF	20%	16V	
C051	1-161-330-00	CERAMIC	0.01MF	30%	25V	
C052	1-161-330-00	CERAMIC	0.01MF	30%	25V	
C102	1-124-069-00	ELECT	100MF	20%	10V	
C103	1-130-305-00	FILM	0.022MF	5%	100V	
C104	1-123-830-00	ELECT(NONPOLAR)	4.7MF	20%	50V	
C105	1-130-307-00	FILM	0.027MF	5%	100V	

### NOTE:

- Items with no part number and no description are not stocked because they are seldom required for routine service.
- Items marked "♣" are not stocked since they are seldom required for routine service. Some delay should be anticipated when ordering these items.
- Due to standardization, parts with part numbers (Δ-ΔΔΔ-ΔΔΔ-XX or Δ-ΔΔΔΔ-ΔΔΔ-X) may be different from those used in the set.
- If there are two or more same circuits in a set such as a stereophonic machine, only typical circuit parts may be indicated and capacitors and resistors in other same circuits may be omitted.

### CAPACITORS:

MF:μF, PF:μμF.

### RESISTORS

- All resistors are in ohms.
- F: nonflammable

### COILS

- MMH: mH, UH: μH

### SEMICONDUCTORS

In each case, U: μ, for example:  
 UA...: μA..., UPA...: μPA..., UPC...: μPC,  
 UPD...: μPD...

The components identified by shading and mark ♣ are critical for safety. Replace only with part number specified.

## ELECTRICAL PARTS

Ref.No.	Part No.	Description			
C106	1-107-300-00	MICA	100PF	5%	100V
C107	1-130-281-00	FILM	0.0022MF	5%	100V
C110	1-130-630-00	FILM	0.068MF	5%	50V
C111	1-130-630-00	FILM	0.068MF	5%	50V
C112	1-130-635-00	FILM	0.18MF	5%	50V
C113	1-130-635-00	FILM	0.18MF	5%	50V
C114	1-123-828-00	ELECT(NONPOLAR)	1MF	20%	50V
C115	1-130-625-00	FILM	0.027MF	5%	50V
C116	1-130-630-00	FILM	0.068MF	5%	50V
C117	1-130-635-00	FILM	0.18MF	5%	50V
C118	1-130-633-00	FILM	0.12MF	5%	50V
C119	1-123-828-00	ELECT(NONPOLAR)	1MF	20%	50V
C120	1-130-297-00	FILM	0.01MF	5%	100V
C121	1-130-892-00	FILM	0.015MF	3%	100V
C122	1-130-955-00	FILM	0.01MF	3%	100V
C123	1-107-284-00	MICA	22PF	5%	100V
C126	1-123-830-00	ELECT(NONPOLAR)	4.7MF	20%	50V
C301	1-124-090-00	ELECT	3.3MF	20%	50V
C302	1-124-069-00	ELECT	100MF	20%	10V
C303	1-124-092-00	ELECT	10MF	20%	50V
C304	1-124-092-00	ELECT	10MF	20%	50V
C305	1-124-069-00	ELECT	100MF	20%	10V
C307	1-130-630-00	FILM	0.068MF	5%	50V
C308	1-130-630-00	FILM	0.068MF	5%	50V
C309	1-130-635-00	FILM	0.18MF	5%	50V
C310	1-130-635-00	FILM	0.18MF	5%	50V
C311	1-123-828-00	ELECT(NONPOLAR)	1MF	20%	50V
C312	1-130-625-00	FILM	0.027MF	5%	50V
C313	1-130-635-00	FILM	0.18MF	5%	50V
C314	1-130-630-00	FILM	0.068MF	5%	50V
C315	1-130-633-00	FILM	0.12MF	5%	50V
C316	1-123-828-00	ELECT(NONPOLAR)	1MF	20%	50V
C317	1-130-297-00	FILM	0.01MF	5%	100V
C318	1-130-892-00	FILM	0.015MF	3%	100V
C319	1-130-955-00	FILM	0.01MF	3%	100V
C322	1-123-830-00	ELECT(NONPOLAR)	4.7MF	20%	50V
C323	1-123-831-00	ELECT(NONPOLAR)	10MF	20%	50V
C324	1-123-830-00	ELECT(NONPOLAR)	4.7MF	20%	50V
C326	1-124-069-00	ELECT	100MF	20%	10V
C327	1-130-625-00	FILM	0.027MF	5%	50V
C330	1-123-831-00	ELECT(NONPOLAR)	10MF	20%	50V
C331	1-130-277-00	FILM	0.0015MF	5%	100V
C332	1-107-172-00	MICA	130PF	5%	500V
C334	1-130-621-00	FILM	0.012MF	5%	50V
C335	1-130-622-00	FILM	0.015MF	5%	50V

## ELECTRICAL PARTS

Ref.No.	Part No.	Description			
C336	1-130-621-00	FILM	0.012MF	5%	50V
C337	1-130-628-00	FILM	0.047MF	5%	50V
C338	1-130-621-00	FILM	0.012MF	5%	50V
C339	1-130-625-00	FILM	0.027MF	5%	50V
C340	1-130-622-00	FILM	0.015MF	5%	50V
C342	1-123-353-00	ELECT	2.2MF	20%	50V
C343	1-130-634-00	FILM	0.15MF	5%	50V
C344	1-123-328-00	ELECT	4.7MF	20%	25V
C345	1-123-353-00	ELECT	2.2MF	20%	50V
C347	1-161-327-00	CERAMIC	0.0033MF	30%	50V
C501	1-124-069-00	ELECT	100MF	20%	10V
C502	1-124-069-00	ELECT	100MF	20%	10V
C503	1-123-353-00	ELECT	2.2MF	20%	50V
C504	1-123-380-00	ELECT	1MF	20%	50V
C505	1-123-380-00	ELECT	1MF	20%	50V
C506	1-123-332-00	ELECT	47MF	20%	25V
C509	1-123-353-00	ELECT	2.2MF	20%	50V
C510	1-123-356-00	ELECT	10MF	20%	25V
C511	1-141-225-00	CAP, TRIMMER			
C512	1-124-078-00	ELECT	2200MF	20%	16V
C513	1-124-068-00	ELECT	47MF	20%	10V
C514	1-123-324-00	ELECT	1000MF	20%	16V
C515	1-124-078-00	ELECT	2200MF	20%	16V
C516	1-124-068-00	ELECT	47MF	20%	10V
C517	1-123-324-00	ELECT	1000MF	20%	16V
C518	1-124-069-00	ELECT	100MF	20%	10V
C519	1-124-069-00	ELECT	100MF	20%	10V
C521	1-124-081-00	ELECT	47MF	20%	25V
C522	1-124-081-00	ELECT	47MF	20%	25V
C523	1-123-320-00	ELECT	100MF	20%	16V
C524	1-123-328-00	ELECT	4.7MF	20%	25V
C525	1-124-081-00	ELECT	47MF	20%	25V
C526	1-124-081-00	ELECT	47MF	20%	25V
C527	1-124-081-00	ELECT	47MF	20%	25V
C528	1-124-081-00	ELECT	47MF	20%	25V
C529	1-123-306-00	ELECT	47MF	20%	10V
C530	1-123-306-00	ELECT	47MF	20%	10V
C531	1-131-347-00	TANTALUM	1MF	20%	35V
C532	1-131-347-00	TANTALUM	1MF	20%	35V
C601	1-130-623-00	FILM	0.018MF	5%	50V
C602	1-123-354-00	ELECT	3.3MF	20%	50V
C603	1-161-321-00	CERAMIC	680PF	10%	50V
C604	1-161-321-00	CERAMIC	680PF	10%	50V
C605	1-161-330-00	CERAMIC	0.01MF	30%	25V
C606	1-161-330-00	CERAMIC	0.01MF	30%	25V

### NOTE:

- Items with no part number and no description are not stocked because they are seldom required for routine service.
- Items marked "▲" are not stocked since they are seldom required for routine service. Some delay should be anticipated when ordering these items.
- Due to standardization, parts with part numbers (Δ-ΔΔΔ-ΔΔΔ-XX or Δ-ΔΔΔΔ-ΔΔΔ-X) may be different from those used in the set.
- If there are two or more same circuits in a set such as a stereophonic machine, only typical circuit parts may be indicated and capacitors and resistors in other same circuits may be omitted.

### CAPACITORS:

MF: μF, PF: μμF.

### RESISTORS

- All resistors are in ohms.
- F: nonflammable

### COILS

- MMH: mH, UH: μH

### SEMICONDUCTORS

In each case, U: μ, for example:  
 UA...: μA..., UPA...: μPA..., UPC...: μPC,  
 UPD...: μPD...

The components identified by shading and mark ▲ are critical for safety. Replace only with part number specified.

## ELECTRICAL PARTS

Ref.No.	Part No.	Description			
C607	1-123-380-00	ELECT	1MF	20%	50V
C608	1-123-380-00	ELECT	1MF	20%	50V
C609	1-123-356-00	ELECT	10MF	20%	50V
C701	1-123-338-00	ELECT	2200MF	20%	25V
C702	1-123-338-00	ELECT	2200MF	20%	25V
C703	1-123-338-00	ELECT	2200MF	20%	25V
C704	1-123-338-00	ELECT	2200MF	20%	25V
C705	1-123-335-00	ELECT	330MF	20%	25V
C706	1-123-362-00	ELECT	330MF	20%	50V
C707	1-123-356-00	ELECT	10MF	20%	16V
C708	1-123-358-00	ELECT	33MF	20%	50V
C709	1-123-354-00	ELECT	3.3MF	20%	50V
C710	1-123-318-00	ELECT	33MF	20%	16V
C711	1-123-318-00	ELECT	33MF	20%	16V
C712	1-123-318-00	ELECT	33MF	20%	16V
C713	1-123-318-00	ELECT	33MF	20%	16V
C714	1-123-299-00	ELECT	1000MF	20%	6.3V
C717	1-123-306-00	ELECT	47MF	20%	10V
C718	1-123-306-00	ELECT	47MF	20%	10V
C719	1-123-369-00	ELECT	4.7MF	20%	50V
C720	1-123-380-00	ELECT	1MF	20%	50V
C721	1-161-271-00	CERAMIC	100PF	5%	50V
C722	1-161-271-00	CERAMIC	100PF	5%	50V
C723	1-123-296-00	ELECT	220MF	20%	6.3V
C724	1-123-296-00	ELECT	220MF	20%	6.3V
C725	1-123-296-00	ELECT	220MF	20%	6.3V
C726	1-123-295-00	ELECT	100MF	20%	6.3V
C727	1-130-626-00	FILM	0.033MF	5%	50V
C728	1-123-380-00	ELECT	1MF	20%	50V
C729	1-123-380-00	ELECT	1MF	20%	50V
C730	1-123-380-00	ELECT	1MF	20%	50V
C731	1-123-369-00	ELECT	4.7MF	20%	50V
C732	1-123-380-00	ELECT	1MF	20%	50V
C733	1-123-380-00	ELECT	1MF	20%	50V
C734	1-161-330-00	CERAMIC	0.01MF	30%	25V
C735	1-161-330-00	CERAMIC	0.01MF	30%	25V
C736	1-161-330-00	CERAMIC	0.01MF	30%	25V
C737	1-123-369-00	ELECT	4.7MF	20%	50V
C738	1-161-130-00	CERAMIC	0.001MF	20%	25V
C739	1-161-130-00	CERAMIC	0.001MF	20%	25V
C751	▲ 1-161-744-00	CERAMIC	0.01MF		400V

- ▲ CNP001;1-508-882-00 BASE POST
- ▲ CNP002;1-560-605-00 PIN, CONNECTOR 6P
- ▲ CNP003;1-560-605-00 PIN, CONNECTOR 6P

## ELECTRICAL PARTS

Ref.No.	Part No.	Description
▲ CNP004;1-560-605-00	PIN, CONNECTOR 6P	
▲ CNP013;1-560-060-00	PIN, CONNECTOR 2P	
▲ CNP10 ;1-560-060-00	PIN, CONNECTOR 2P	
▲ CNP103;1-560-062-00	PIN, CONNECTOR 4P	
▲ CNP105;1-560-060-00	PIN, CONNECTOR 2P	
▲ CNP701;1-560-060-00	PIN, CONNECTOR 2P	
▲ CNP702;1-560-062-00	PIN, CONNECTOR 4P	
▲ CNP703;1-560-064-00	PIN, CONNECTOR 6P	
▲ CNP704;1-560-063-00	PIN, CONNECTOR 5P	
▲ CNP705;1-560-065-00	PIN, CONNECTOR 8P	
▲ CNP706;1-560-061-00	PIN, CONNECTOR 3P	
▲ CNP708;1-560-060-00	PIN, CONNECTOR 2P	
▲ CNP709;1-560-060-00	PIN, CONNECTOR 2P	
▲ CNP711;1-560-065-00	PIN, CONNECTOR 8P	
▲ CNP712;1-560-063-00	PIN, CONNECTOR 5P (FOR PLAYBACK BOARD)	
▲ CNP712;1-560-063-00	PIN, CONNECTOR 5P (FOR SYSTEM CONTROL BOARD)	
▲ CNP713;1-560-338-00	PIN, CONNECTOR 7P	
▲ CNP714;1-560-061-00	PIN, CONNECTOR 3P (FOR PLAYBACK BOARD)	
▲ CNP714;1-560-062-00	PIN, CONNECTOR 4P (FOR SYSTEM CONTROL BOARD)	
▲ CNP715;1-560-063-00	PIN, CONNECTOR 5P	
▲ CNP729;1-560-061-00	PIN, CONNECTOR 3P	
▲ CNP730;1-508-881-00	BASE POST	
D001	8-719-815-55 DIODE 1S1555	
D002	8-719-200-02 DIODE 10E2	
D003	8-719-200-02 DIODE 10E2	
D004	8-719-815-55 DIODE 1S1555	
D101	8-719-910-64 DIODE HZ6B1L	
D201	8-719-910-64 DIODE HZ6B1L	
D501	8-719-815-55 DIODE 1S1555	
D502	8-719-815-55 DIODE 1S1555	
D504	8-719-815-55 DIODE 1S1555	
D505	8-719-815-55 DIODE 1S1555	
D506	8-719-910-64 DIODE HZ6B1L	
D507	8-719-910-64 DIODE HZ6B1L	
D601	8-719-815-55 DIODE 1S1555	
D602	8-719-815-55 DIODE 1S1555	
D603	8-719-815-55 DIODE 1S1555	
D604	8-719-815-55 DIODE 1S1555	
D605	8-719-910-03 DIODE HZ20-3L	
D701	8-719-210-12 DIODE 10DF2	
D702	8-719-210-12 DIODE 10DF2	
D703	8-719-210-12 DIODE 10DF2	
D704	8-719-210-12 DIODE 10DF2	

### NOTE:

- Items with no part number and no description are not stocked because they are seldom required for routine service.
- Items marked "▲" are not stocked since they are seldom required for routine service. Some delay should be anticipated when ordering these items.
- Due to standardization, parts with part numbers (Δ-ΔΔΔ-ΔΔΔ-XX or Δ-ΔΔΔΔ-ΔΔΔ-X) may be different from those used in the set.
- If there are two or more same circuits in a set such as a stereophonic machine, only typical circuit parts may be indicated and capacitors and resistors in other same circuits may be omitted.

### CAPACITORS:

MF: μF, PF: μμF.

### RESISTORS

- All resistors are in ohms.
- F: nonflammable

### COILS

- MMH: mH, UH: μH

### SEMICONDUCTORS

In each case, U: μ, for example:  
 UA...: μA..., UPA...: μPA..., UPC...: μPC,  
 UPD...: μPD...

The components identified by shading and mark ▲ are critical for safety. Replace only with part number specified.



## ELECTRICAL PARTS

Ref.No.	Part No.	Description
D705	8-719-200-02	DIODE 10E2
D706	8-719-200-02	DIODE 10E2
D707	8-719-200-02	DIODE 10E2
D708	8-719-200-02	DIODE 10E2
D709	8-719-200-02	DIODE 10E2
D710	8-719-200-02	DIODE 10E2
D711	8-719-910-61	DIODE HZ6A1L
D712	8-719-922-73	DIODE HZ27-3L
D713	8-719-200-02	DIODE 10E2
D714	8-719-200-02	DIODE 10E2
D715	8-719-815-55	DIODE 1S1555
D716	8-719-200-02	DIODE 10E2
D718	8-719-910-96	DIODE HZ9B3L
D719	8-719-200-02	DIODE 10E2
D720	8-719-200-02	DIODE 10E2
D721	8-719-815-55	DIODE 1S1555
D722	8-719-815-55	DIODE 1S1555
D723	8-719-815-55	DIODE 1S1555
D724	8-719-815-55	DIODE 1S1555
D725	8-719-815-55	DIODE 1S1555
D726	8-719-934-33	DIODE PY3432S
D727	8-719-914-32	DIODE PG3432S
D728	8-719-934-33	DIODE PY3432S
D729	8-719-934-32	DIODE AR3432S
D730	8-719-934-34	DIODE AA3432S
F701	▲.1-532-078-00	FUSE, TIME-LAG 1A
F702	▲.1-532-078-00	FUSE, TIME-LAG 1A
FG	1-459-426-00	COIL
FL601	1-519-273-00	INDICATOR TUBE, FLOURESCENT
H001	8-719-800-11	DIODE THS105
H002	8-719-800-11	DIODE THS105
H003	8-719-800-11	DIODE THS105
H004	8-719-800-11	DIODE THS105
H005	8-719-800-11	DIODE THS105
H006	8-719-800-11	DIODE THS105
HE101	8-825-535-30	HEAD, ERASE (ES237-36A)
HP101	8-825-500-30	HEAD, REC/PB (RPA230-3602)
HR101		
IC001	8-759-101-02	IC CX10031
IC002	8-759-145-58	IC UPC4558C
IC003	8-759-958-14	IC MSM58141RS
IC004	8-759-101-02	IC CX10031
IC005	8-759-101-02	IC CX10031
IC006	8-759-145-58	IC UPC4558C

## ELECTRICAL PARTS

Ref.No.	Part No.	Description
IC007	8-759-145-58	IC UPC4558C
IC101	8-752-008-80	IC CX20088
IC201	8-752-008-70	IC CX20087
IC301	8-752-008-70	IC CX20087
IC302	8-759-745-60	IC NJM4560D
IC401	8-752-008-80	IC CX20088
IC402	8-759-745-60	IC NJM4560D
IC501	8-759-700-04	IC NJM2043D-D
IC502	8-759-961-38	IC BA6138
IC503	8-759-145-57	IC UPC4557C
IC504	8-759-145-58	IC UPC4558C
IC601	8-759-985-01	IC MB84001B
IC602	8-759-981-12	IC MSL912RS
IC603	8-759-904-72	IC MSL9359RS
IC604	8-759-981-12	IC MSL912RS
IC701	8-759-700-47	IC CX10035
IC702	8-759-220-04	IC TC40H004P
IC703	8-759-101-09	IC UPD1511C108
IC704	8-759-240-19	IC TC4019BP
IC705	8-759-700-46	IC CX10034
IC706	8-759-100-99	IC UPD1511C103
IC707	8-759-240-69	IC TC4069UBP
IC708	8-759-145-58	IC UPC4558C
IC709	8-759-133-90	IC UPC339C
J301	1-507-531-31	PLATE, PIN-JACK
J302		
J401		
J402		
J303	1-507-659-00	JACK
J701	1-561-598-00	SOCKET 4P
L001	1-407-157-XX	MICRO INDUCTOR 10UH
L002	1-407-157-XX	MICRO INDUCTOR 10UH
L003	1-407-157-XX	MICRO INDUCTOR 10UH
L004	1-407-157-XX	MICRO INDUCTOR 10UH
L005	1-407-157-XX	MICRO INDUCTOR 10UH
L006	1-407-157-XX	MICRO INDUCTOR 10UH
L007	1-407-157-XX	MICRO INDUCTOR 10UH
L008	1-407-157-XX	MICRO INDUCTOR 10UH
L009	1-407-157-XX	MICRO INDUCTOR 10UH
L010	1-407-157-XX	MICRO INDUCTOR 10UH
L011	1-407-157-XX	MICRO INDUCTOR 10UH
L012	1-407-157-XX	MICRO INDUCTOR 10UH
L301	1-408-259-00	MICRO INDUCTOR 15MMH
L302	1-408-253-00	MICRO INDUCTOR 4.7MMH
L303	1-408-252-00	MICRO INDUCTOR 3.9MMH

### NOTE:

- Items with no part number and no description are not stocked because they are seldom required for routine service.
- Items marked "▲" are not stocked since they are seldom required for routine service. Some delay should be anticipated when ordering these items.
- Due to standardization, parts with part numbers (Δ-ΔΔΔ-ΔΔΔ-XX or Δ-ΔΔΔΔ-ΔΔΔ-X) may be different from those used in the set.
- If there are two or more same circuits in a set such as a stereophonic machine, only typical circuit parts may be indicated and capacitors and resistors in other same circuits may be omitted.

### CAPACITORS:

MF:μF, PF:μμF.

### RESISTORS

All resistors are in ohms.

F : nonflammable

### COILS

MMH : mH, UH : μH

### SEMICONDUCTORS

In each case, U : μ, for example:

UA...: μA..., UPA...: μPA..., UPC...: μPC,

UPD...: μPD...

The components identified by shading and mark ▲ are critical for safety. Replace only with part number specified.

## ELECTRICAL PARTS

Ref.No.	Part No.	Description
L304	1-408-252-00	MICRO INDUCTOR 3.9MMH
L305	1-408-249-00	MICRO INDUCTOR 2.2MMH
L401	1-408-259-00	MICRO INDUCTOR 15MMH
L402	1-408-253-00	MICRO INDUCTOR 4.7MMH
L403	1-408-252-00	MICRO INDUCTOR 3.9MMH
L404	1-408-252-00	MICRO INDUCTOR 3.9MMH
L405	1-408-249-00	MICRO INDUCTOR 2.2MMH
LPF301	1-231-388-00	FILTER, LOWPASS
LPF401	1-231-388-00	FILTER, LOWPASS
LV101	1-407-240-00	MICRO INDUCTOR 22MMH
LV102	1-235-186-00	ENCAPSULATED COMPONENT
LV201	1-407-240-00	MICRO INDUCTOR 22MMH
LV202	1-235-186-00	ENCAPSULATED COMPONENT
LV301	1-235-186-00	ENCAPSULATED COMPONENT
LV401	1-235-186-00	ENCAPSULATED COMPONENT
PL001	1-518-515-00	LAMP, PILOT
PL501	1-518-513-00	LAMP, PILOT
PL502	1-518-513-00	LAMP, PILOT
PM001	1-454-342-00	SOLENOID, PLUNGER
PM002	1-454-343-00	SOLENOID, PLUNGER
PS701 <sup>▲</sup>	1-532-685-00	LINK, IC
PS702 <sup>▲</sup>	1-532-685-00	LINK, IC
PT701 <sup>▲</sup>	1-447-555-00	(AEP)...TRANSFORMER, POWER
PT701 <sup>▲</sup>	1-447-556-00	(E).....TRANSFORMER, POWER
Q001	8-729-602-68	TRANSISTOR 2SA1026-8
Q002	8-729-602-68	TRANSISTOR 2SA1026-8
Q003	8-729-663-48	TRANSISTOR 2SC1364-8
Q004	8-729-663-48	TRANSISTOR 2SC1364-8
Q005	8-729-663-48	TRANSISTOR 2SC1364-8
Q006	8-729-663-48	TRANSISTOR 2SC1364-8
Q007	8-729-663-48	TRANSISTOR 2SC1364-8
Q008	8-729-663-48	TRANSISTOR 2SC1364-8
Q009	8-729-663-48	TRANSISTOR 2SC1364-8
Q101	8-765-660-10	TRANSISTOR 2SK245
Q102	8-729-300-62	TRANSISTOR 2SD666A
Q103	8-729-663-48	TRANSISTOR 2SC1364-8
Q104	8-729-663-48	TRANSISTOR 2SC1364-8
Q201	8-765-660-10	TRANSISTOR 2SK245
Q202	8-729-300-62	TRANSISTOR 2SD666A
Q203	8-729-663-48	TRANSISTOR 2SC1364-8
Q204	8-729-663-48	TRANSISTOR 2SC1364-8
Q301	8-729-334-58	TRANSISTOR 2SC1345
Q302	8-729-663-48	TRANSISTOR 2SC1364-8
Q304	8-729-100-13	TRANSISTOR 2SC2001
Q401	8-729-334-58	TRANSISTOR 2SC1345

## ELECTRICAL PARTS

Ref.No.	Part No.	Description
Q402	8-729-663-48	TRANSISTOR 2SC1364-8
Q404	8-729-100-13	TRANSISTOR 2SC2001
Q501	8-729-100-13	TRANSISTOR 2SC2001
Q502	8-729-100-13	TRANSISTOR 2SC2001
Q503	8-729-100-13	TRANSISTOR 2SC2001
Q504	8-729-602-67	TRANSISTOR 2SA1026-7
Q505	8-729-663-47	TRANSISTOR 2SC1364
Q506	8-729-663-47	TRANSISTOR 2SC1364
Q507	8-729-602-67	TRANSISTOR 2SA1026-7
Q508	8-729-281-53	TRANSISTOR 2SC1815-GR
Q509	8-729-281-53	TRANSISTOR 2SC1815-GR
Q510	8-729-663-47	TRANSISTOR 2SC1364 (FOR RECORD BOARD)
Q510	8-769-042-00	TRANSISTOR 2SK120-2 (FOR PLAYBACK BOARD)
Q511	8-729-167-62	TRANSISTOR 2SC2676
Q512	8-729-180-93	TRANSISTOR 2SD809
Q513	8-729-167-62	TRANSISTOR 2SC2676
Q514	8-769-042-00	TRANSISTOR 2SK120-2
Q515	8-729-113-82	TRANSISTOR 2SA1138
Q516	8-729-173-13	TRANSISTOR 2SB731
Q517	8-729-113-82	TRANSISTOR 2SA1138
Q601	8-729-663-47	TRANSISTOR 2SC1364
Q602	8-729-663-47	TRANSISTOR 2SC1364
Q603	8-729-663-47	TRANSISTOR 2SC1364
Q604	8-729-663-47	TRANSISTOR 2SC1364
Q605	8-729-663-47	TRANSISTOR 2SC1364
Q606	8-729-612-77	TRANSISTOR 2SA1027R
Q607	8-729-612-77	TRANSISTOR 2SA1027R
Q608	8-729-612-77	TRANSISTOR 2SA1027R
Q609	8-729-612-77	TRANSISTOR 2SA1027R
Q610	8-729-663-47	TRANSISTOR 2SC1364
Q611	8-729-612-77	TRANSISTOR 2SA1027R
Q612	8-729-612-77	TRANSISTOR 2SA1027R
Q613	8-729-663-47	TRANSISTOR 2SC1364
Q614	8-729-612-77	TRANSISTOR 2SA1027R
Q615	8-729-663-47	TRANSISTOR 2SC1364
Q616	8-729-612-77	TRANSISTOR 2SA1027R
Q617	8-729-177-43	TRANSISTOR 2SD774
Q701	8-729-180-93	TRANSISTOR 2SD809
Q702	8-729-663-47	TRANSISTOR 2SC1364
Q703	8-729-612-77	TRANSISTOR 2SA1027R
Q704	8-729-612-77	TRANSISTOR 2SA1027R
Q705	8-729-612-77	TRANSISTOR 2SA1027R
Q706	8-729-612-77	TRANSISTOR 2SA1027R
Q707	8-729-612-77	TRANSISTOR 2SA1027R
Q708	8-729-103-43	TRANSISTOR 2SB734
Q709	8-729-663-47	TRANSISTOR 2SC1364

### NOTE:

- Items with no part number and no description are not stocked because they are seldom required for routine service.
- Items marked "▲" are not stocked since they are seldom required for routine service. Some delay should be anticipated when ordering these items.
- Due to standardization, parts with part numbers (Δ-ΔΔΔ-ΔΔΔ-XX or Δ-ΔΔΔΔ-ΔΔΔ-X) may be different from those used in the set.
- If there are two or more same circuits in a set such as a stereophonic machine, only typical circuit parts may be indicated and capacitors and resistors in other same circuits may be omitted.

### CAPACITORS:

MF: μF, PF: μμF.

### RESISTORS

- All resistors are in ohms.
- F : nonflammable

### COILS

MMH : mH, UH : μH

### SEMICONDUCTORS

In each case, U : μ, for example:  
 UA... : μA..., UPA... : μPA..., UPC... : μPC,  
 UPD... : μPD...

The components identified by shading and mark ▲ are critical for safety. Replace only with part number specified.

## ELECTRICAL PARTS

Ref.No.	Part No.	Description			
Q710	8-729-103-43	TRANSISTOR	2SB734		
Q711	8-729-663-47	TRANSISTOR	2SC1364		
Q712	8-729-612-77	TRANSISTOR	2SA1027R		
Q713	8-729-177-43	TRANSISTOR	2SD774		
Q714	8-729-612-77	TRANSISTOR	2SA1027R		
Q715	8-729-177-43	TRANSISTOR	2SD774		
Q716	8-729-663-47	TRANSISTOR	2SC1364		
Q717	8-729-180-93	TRANSISTOR	2SD809		
Q718	8-729-180-93	TRANSISTOR	2SD809		
Q719	8-729-173-13	TRANSISTOR	2SB731		
Q721	8-729-180-93	TRANSISTOR	2SD809		
R001	1-247-831-00	CARBON	1K	5%	1/6W
R002	1-247-831-00	CARBON	1K	5%	1/6W
R003	1-247-887-00	CARBON	220K	5%	1/6W
R004	1-214-779-00	METAL	120K	1%	1/4W
R005	1-246-521-00	CARBON	100K	5%	1/4W
R006	1-214-775-00	METAL	82K	1%	1/4W
R007	1-246-545-00	CARBON	1M	5%	1/4W
R008	1-246-521-00	CARBON	100K	5%	1/4W
R009	1-214-737-00	METAL	2.2K	1%	1/4W
R010	1-214-753-00	METAL	10K	1%	1/4W
R015	1-247-863-00	CARBON	22K	5%	1/6W
R016	1-247-863-00	CARBON	22K	5%	1/6W
R019	1-247-807-00	CARBON	100	5%	1/6W
R020	1-247-807-00	CARBON	100	5%	1/6W
R021	1-247-807-00	CARBON	100	5%	1/6W
R022	1-247-807-00	CARBON	100	5%	1/6W
R023	1-247-863-00	CARBON	22K	5%	1/6W
R024	1-247-863-00	CARBON	22K	5%	1/6W
R025	1-247-863-00	CARBON	22K	5%	1/6W
R026	1-247-863-00	CARBON	22K	5%	1/6W
R027	1-246-519-00	CARBON	82K	5%	1/4W
R028	1-246-519-00	CARBON	82K	5%	1/4W
R029	1-247-863-00	CARBON	22K	5%	1/6W
R030	1-247-863-00	CARBON	22K	5%	1/6W
R031	1-247-855-00	CARBON	10K	5%	1/6W
R032	1-247-855-00	CARBON	10K	5%	1/6W
R033	1-247-867-00	CARBON	33K	5%	1/6W
R034	1-247-839-00	CARBON	2.2K	5%	1/6W
R035	1-247-855-00	CARBON	10K	5%	1/6W
R036	1-247-863-00	CARBON	22K	5%	1/6W
R037	1-247-839-00	CARBON	2.2K	5%	1/6W
R038	1-247-827-00	CARBON	680	5%	1/6W
R039	1-247-843-00	CARBON	3.3K	5%	1/6W

## ELECTRICAL PARTS

Ref.No.	Part No.	Description			
R040	1-247-867-00	CARBON	33K	5%	1/6W
R041	1-247-839-00	CARBON	2.2K	5%	1/6W
R042	1-247-807-00	CARBON	100	5%	1/6W
R043	1-247-839-00	CARBON	2.2K	5%	1/6W
R044	1-247-863-00	CARBON	22K	5%	1/6W
R045	1-247-839-00	CARBON	2.2K	5%	1/6W
R046	1-247-839-00	CARBON	2.2K	5%	1/6W
R047	1-247-895-00	CARBON	470K	5%	1/6W
R048	1-247-855-00	CARBON	10K	5%	1/6W
R049	1-247-839-00	CARBON	2.2K	5%	1/6W
R050	1-247-839-00	CARBON	2.2K	5%	1/6W
R051	1-247-895-00	CARBON	470K	5%	1/6W
R052	1-247-855-00	CARBON	10K	5%	1/6W
R053	1-247-839-00	CARBON	2.2K	5%	1/6W
R054	1-247-839-00	CARBON	2.2K	5%	1/6W
R055	1-247-895-00	CARBON	470K	5%	1/6W
R056	1-247-855-00	CARBON	10K	5%	1/6W
R057	1-247-839-00	CARBON	2.2K	5%	1/6W
R058	1-247-839-00	CARBON	2.2K	5%	1/6W
R059	1-247-895-00	CARBON	470K	5%	1/6W
R060	1-247-855-00	CARBON	10K	5%	1/6W
R062	1-247-831-00	CARBON	1K	5%	1/6W
R063	1-246-497-00	CARBON	10K	5%	1/4W
R064	1-246-497-00	CARBON	10K	5%	1/4W
R065	1-244-756-00	CARBON	3M	5%	1/4W
R067	1-247-843-00	CARBON	3.3K	5%	1/6W
R068	1-246-461-00	CARBON	330	5%	1/4W
R069	1-246-461-00	CARBON	330	5%	1/4W
R102	1-246-470-00	CARBON	750	5%	1/4W
R103	1-246-470-00	CARBON	750	5%	1/4W
R105	1-246-437-00	CARBON	33	5%	1/4W
R106	1-246-437-00	CARBON	33	5%	1/4W
R107	1-214-715-00	METAL	270	1%	1/4W
R108	1-246-479-00	CARBON	1.8K	5%	1/4W
R109	1-246-480-00	CARBON	2K	5%	1/4W
R110	1-246-485-00	CARBON	3.3K	5%	1/4W
R111	1-214-840-00	METAL	100	1%	1/2W
R112	1-214-881-00	METAL	5.1K	1%	1/2W
R113	1-214-916-00	METAL	130K	1%	1/2W
R114	1-244-881-00	CARBON	2.2K	5%	1/2W
R115	1-244-883-00	CARBON	2.7K	5%	1/2W
R116	1-244-929-00	CARBON	220K	5%	1/2W
R117	1-246-497-00	CARBON	10K	5%	1/4W
R118	1-246-521-00	CARBON	100K	5%	1/4W
R119	1-214-131-00	METAL	910	1%	1/4W

### NOTE:

- Items with no part number and no description are not stocked because they are seldom required for routine service.
- Items marked "♦" are not stocked since they are seldom required for routine service. Some delay should be anticipated when ordering these items.
- Due to standardization, parts with part numbers (Δ-ΔΔΔ-ΔΔΔ-XX or Δ-ΔΔΔΔ-ΔΔΔ-X) may be different from those used in the set.
- If there are two or more same circuits in a set such as a stereophonic machine, only typical circuit parts may be indicated and capacitors and resistors in other same circuits may be omitted.

### CAPACITORS:

MF:μF, PF:μμF.

### RESISTORS

- All resistors are in ohms.
- F : nonflammable

### COILS

• MMH : mH, UH : μH

### SEMICONDUCTORS

In each case, U : μ, for example:  
 UA...: μA..., UPA...: μPA..., UPC...: μPC,  
 UPD...: μPD...

The components identified by shading and mark **▲** are critical for safety. Replace only with part number specified.

## ELECTRICAL PARTS

Ref.No.	Part No.	Description			
R120	1-214-753-00	METAL	10K	1%	1/4W
R121	1-246-527-00	CARBON	180K	5%	1/4W
R122	1-246-528-00	CARBON	200K	5%	1/4W
R123	1-246-487-00	CARBON	3.9K	5%	1/4W
R124	1-246-528-00	CARBON	200K	5%	1/4W
R125	1-246-527-00	CARBON	180K	5%	1/4W
R126	1-246-462-00	CARBON	360	5%	1/4W
R127	1-246-487-00	CARBON	3.9K	5%	1/4W
R128	1-214-746-00	METAL	5.1K	1%	1/4W
R129	1-246-513-00	CARBON	47K	5%	1/4W
R130	1-214-736-00	METAL	2K	1%	1/4W
R131	1-214-776-00	METAL	91K	1%	1/4W
R132	1-214-740-00	METAL	3K	1%	1/4W
R133	1-246-467-00	CARBON	560	5%	1/4W
R134	1-246-537-00	CARBON	470K	5%	1/4W
R135	1-214-746-00	METAL	5.1K	1%	1/4W
R138	1-246-489-00	CARBON	4.7K	5%	1/4W
R139	1-246-461-00	CARBON	330	5%	1/4W
R301	1-214-899-00	METAL	27K	1%	1/2W
R302	1-214-909-00	METAL	68K	1%	1/2W
R303	1-214-880-00	METAL	4.7K	1%	1/2W
R304	1-246-473-00	CARBON	1K	5%	1/4W
R305	1-246-529-00	CARBON	220K	5%	1/4W
R306	1-246-489-00	CARBON	4.7K	5%	1/4W
R307	1-246-473-00	CARBON	1K	5%	1/4W
R308	1-244-885-00	CARBON	3.3K	5%	1/2W
R309	1-244-893-00	CARBON	6.8K	5%	1/2W
R310	1-244-873-00	CARBON	1K	5%	1/2W
R311	1-246-529-00	CARBON	220K	5%	1/4W
R312	1-246-527-00	CARBON	180K	5%	1/4W
R313	1-246-528-00	CARBON	200K	5%	1/4W
R314	1-246-487-00	CARBON	3.9K	5%	1/4W
R315	1-246-528-00	CARBON	200K	5%	1/4W
R316	1-246-527-00	CARBON	180K	5%	1/4W
R317	1-246-462-00	CARBON	360	5%	1/4W
R318	1-246-487-00	CARBON	3.9K	5%	1/4W
R319	1-246-521-00	CARBON	100K	5%	1/4W
R320	1-214-736-00	METAL	2K	1%	1/4W
R321	1-214-746-00	METAL	5.1K	1%	1/4W
R322	1-246-513-00	CARBON	47K	5%	1/4W
R323	1-214-776-00	METAL	91K	1%	1/4W
R324	1-214-740-00	METAL	3K	1%	1/4W
R325	1-246-467-00	CARBON	560	5%	1/4W
R326	1-246-537-00	CARBON	470K	5%	1/4W
R327	1-214-746-00	METAL	5.1K	1%	1/4W

## ELECTRICAL PARTS

Ref.No.	Part No.	Description			
R328	1-214-762-00	METAL	24K	1%	1/4W
R329	1-214-731-00	METAL	1.2K	1%	1/4W
R330	1-244-872-00	CARBON	910	5%	1/2W
R331	1-244-907-00	CARBON	27K	5%	1/2W
R332	1-246-521-00	CARBON	100K	5%	1/4W
R334	1-244-890-00	CARBON	5.1K	5%	1/2W
R335	1-244-905-00	CARBON	22K	5%	1/2W
R336	1-246-473-00	CARBON	1K	5%	1/4W
R337	1-244-873-00	CARBON	1K	5%	1/2W
R338	1-246-529-00	CARBON	220K	5%	1/4W
R339	1-246-497-00	CARBON	10K	5%	1/4W
R340	1-214-872-00	METAL	2.2K	1%	1/2W
R341	1-244-913-00	CARBON	47K	5%	1/2W
R342	1-214-913-00	METAL	100K	1%	1/2W
R343	1-214-913-00	METAL	100K	1%	1/2W
R344	1-214-872-00	METAL	2.2K	1%	1/2W
R345	1-244-881-00	CARBON	2.2K	5%	1/2W
R346	1-214-872-00	METAL	2.2K	1%	1/2W
R347	1-246-509-00	CARBON	33K	5%	1/4W
R348	1-246-518-00	CARBON	75K	5%	1/4W
R351	1-246-481-00	CARBON	2.2K	5%	1/4W
R352	1-246-433-00	CARBON	22	5%	1/4W
R353	1-246-533-00	CARBON	330K	5%	1/4W
R354	1-246-489-00	CARBON	4.7K	5%	1/4W
R355	1-246-473-00	CARBON	1K	5%	1/4W
R357	1-246-501-00	CARBON	15K	5%	1/4W
R358	1-246-491-00	CARBON	5.6K	5%	1/4W
R359	1-246-489-00	CARBON	4.7K	5%	1/4W
R360	1-246-529-00	CARBON	220K	5%	1/4W
R361	1-246-479-00	CARBON	1.8K	5%	1/4W
R362	1-246-485-00	CARBON	3.3K	5%	1/4W
R363	1-246-483-00	CARBON	2.7K	5%	1/4W
R364	1-246-780-00	CARBON	560	5%	1/8W
R366	1-246-505-00	CARBON	22K	5%	1/4W
R367	1-246-525-00	CARBON	150K	5%	1/4W
R368	1-244-853-00	CARBON	150	5%	1/2W
R369	1-246-453-00	CARBON	150	5%	1/4W
R370	1-246-455-00	CARBON	180	5%	1/4W
R371	1-246-460-00	CARBON	300	5%	1/4W
R372	1-246-451-00	CARBON	120	5%	1/4W
R373	1-246-505-00	CARBON	22K	5%	1/4W
R501	1-246-513-00	CARBON	47K	5%	1/4W
R502	1-246-517-00	CARBON	68K	5%	1/4W
R503	1-246-521-00	CARBON	100K	5%	1/4W
R504	1-246-489-00	CARBON	4.7K	5%	1/4W

### NOTE:

- Items with no part number and no description are not stocked because they are seldom required for routine service.
- Items marked "♦" are not stocked since they are seldom required for routine service. Some delay should be anticipated when ordering these items.
- Due to standardization, parts with part numbers (Δ-ΔΔΔ-ΔΔΔ-XX or Δ-ΔΔΔ-ΔΔΔ-X) may be different from those used in the set.
- If there are two or more same circuits in a set such as a stereophonic machine, only typical circuit parts may be indicated and capacitors and resistors in other same circuits may be omitted.

### CAPACITORS:

MF:μF, PF:μμF.

### RESISTORS

- All resistors are in ohms.
- F : nonflammable

### COILS

- MMH : mH, UH : μH

### SEMICONDUCTORS

In each case, U : μ, for example:  
 UA...: μA..., UPA...: μPA..., UPC...: μPC,  
 UPD...: μPD...

The components identified by shading and mark  are critical for safety. Replace only with part number specified.

## ELECTRICAL PARTS

Ref.No.	Part No.	Description			
R505	1-246-495-00	CARBON	8.2K	5%	1/4W
R506	1-244-849-00	CARBON	100	5%	1/2W
R507	1-244-849-00	CARBON	100	5%	1/2W
R508	1-246-521-00	CARBON	100K	5%	1/4W
R509	1-246-521-00	CARBON	100K	5%	1/4W
R510	1-246-517-00	CARBON	68K	5%	1/4W
R511	1-246-473-00	CARBON	1K	5%	1/4W
R512	1-246-509-00	CARBON	33K	5%	1/4W
R515	1-246-513-00	CARBON	47K	5%	1/4W
R516	1-246-489-00	CARBON	4.7K	5%	1/4W
R517	1-246-505-00	CARBON	22K	5%	1/4W
R518	1-246-513-00	CARBON	47K	5%	1/4W
R520	1-246-488-00	CARBON	4.3K	5%	1/4W
R521	1-246-507-00	CARBON	27K	5%	1/4W
R522	1-246-494-00	CARBON	7.5K	5%	1/4W
R523	1-246-486-00	CARBON	3.6K	5%	1/4W
R524	1-246-497-00	CARBON	10K	5%	1/4W
R525	1-246-409-00	CARBON	2.2	5%	1/4W
R526	1-214-852-00	METAL	330	1%	1/2W
R527	1-214-862-00	METAL	820	1%	1/2W
R528	1-246-509-00	CARBON	33K	5%	1/4W
R529	1-214-862-00	METAL	820	1%	1/2W
R530	1-214-852-00	METAL	330	1%	1/2W
R531	1-246-509-00	CARBON	33K	5%	1/4W
R532	1-246-486-00	CARBON	3.6K	5%	1/4W
R533	1-246-481-00	CARBON	2.2K	5%	1/4W
R534	1-246-505-00	CARBON	22K	5%	1/4W
R535	1-246-521-00	CARBON	100K	5%	1/4W
R536	1-246-505-00	CARBON	22K	5%	1/4W
R537	1-246-481-00	CARBON	2.2K	5%	1/4W
R538	1-246-505-00	CARBON	22K	5%	1/4W
R539	1-244-829-00	CARBON	15	5%	1/2W (FOR RECORD BOARD)
R539	1-244-839-00	CARBON	39	5%	1/2W (FOR PLAYBACK BOARD)
R540	1-246-485-00	CARBON	3.3K	5%	1/4W
R541	1-246-485-00	CARBON	3.3K	5%	1/4W
R598	1-246-473-00	CARBON	1K	5%	1/4W
R599	1-246-459-00	CARBON	270	5%	1/4W
R601	1-246-799-00	CARBON	22K	5%	1/8W
R602	1-246-799-00	CARBON	22K	5%	1/8W
R603	1-246-792-00	CARBON	5.6K	5%	1/8W
R604	1-246-799-00	CARBON	22K	5%	1/8W
R605	1-246-799-00	CARBON	22K	5%	1/8W
R606	1-246-799-00	CARBON	22K	5%	1/8W
R607	1-246-803-00	CARBON	47K	5%	1/8W
R608	1-246-799-00	CARBON	22K	5%	1/8W
R609	1-246-799-00	CARBON	22K	5%	1/8W

## ELECTRICAL PARTS

Ref.No.	Part No.	Description			
R610	1-246-803-00	CARBON	47K	5%	1/8W
R611	1-246-799-00	CARBON	22K	5%	1/8W
R612	1-246-799-00	CARBON	22K	5%	1/8W
R613	1-246-803-00	CARBON	47K	5%	1/8W
R614	1-246-799-00	CARBON	22K	5%	1/8W
R615	1-246-799-00	CARBON	22K	5%	1/8W
R616	1-246-803-00	CARBON	47K	5%	1/8W
R617	1-246-805-00	CARBON	68K	5%	1/8W
R618	1-246-805-00	CARBON	68K	5%	1/8W
R619	1-246-805-00	CARBON	68K	5%	1/8W
R620	1-246-805-00	CARBON	68K	5%	1/8W
R621	1-246-792-00	CARBON	5.6K	5%	1/8W
R622	1-246-799-00	CARBON	22K	5%	1/8W
R623	1-246-804-00	CARBON	56K	5%	1/8W
R624	1-246-804-00	CARBON	56K	5%	1/8W
R625	1-246-807-00	CARBON	100K	5%	1/8W
R626	1-247-047-00	CARBON	330K	5%	1/8W
R627	1-246-795-00	CARBON	10K	5%	1/8W
R628	1-246-783-00	CARBON	1K	5%	1/8W
R629	1-246-799-00	CARBON	22K	5%	1/8W
R630	1-246-795-00	CARBON	10K	5%	1/8W
R631	1-246-783-00	CARBON	1K	5%	1/8W
R632	1-246-799-00	CARBON	22K	5%	1/8W
R633	1-246-799-00	CARBON	22K	5%	1/8W
R634	1-246-803-00	CARBON	47K	5%	1/8W
R635	1-246-799-00	CARBON	22K	5%	1/8W
R636	1-246-805-00	CARBON	68K	5%	1/8W
R637	1-246-799-00	CARBON	22K	5%	1/8W
R638	1-246-803-00	CARBON	47K	5%	1/8W
R639	1-246-799-00	CARBON	22K	5%	1/8W
R640	1-246-805-00	CARBON	68K	5%	1/8W
R641	1-246-792-00	CARBON	5.6K	5%	1/8W
R703	△ 1-217-418-00	FUSIBLE	0.47	10%	1/2W F
R704	△ 1-217-418-00	FUSIBLE	0.47	10%	1/2W F
R705	1-246-470-00	CARBON	750	5%	1/4W
R706	1-246-491-00	CARBON	5.6K	5%	1/4W
R707	1-246-461-00	CARBON	330	5%	1/4W
R708	1-246-491-00	CARBON	5.6K	5%	1/4W
R711	1-246-482-00	CARBON	2.4K	5%	1/4W
R713	1-246-489-00	CARBON	4.7K	5%	1/4W
R714	1-246-467-00	CARBON	560	5%	1/4W
R715	1-246-467-00	CARBON	560	5%	1/4W
R716	1-246-480-00	CARBON	2K	5%	1/4W
R717	1-246-505-00	CARBON	22K	5%	1/4W
R718	1-247-831-00	CARBON	1K	5%	1/6W

### NOTE:

- Items with no part number and no description are not stocked because they are seldom required for routine service.
- Items marked "△" are not stocked since they are seldom required for routine service. Some delay should be anticipated when ordering these items.
- Due to standardization, parts with part numbers (Δ-ΔΔΔ-ΔΔΔ-XX or Δ-ΔΔΔΔ-ΔΔΔ-X) may be different from those used in the set.
- If there are two or more same circuits in a set such as a stereophonic machine, only typical circuit parts may be indicated and capacitors and resistors in other same circuits may be omitted.

### CAPACITORS:

MF: μF, PF: μμF.

### RESISTORS

All resistors are in ohms.

F: nonflammable

### COILS

MMH: mH, UH: μH

### SEMICONDUCTORS

In each case, U: μ, for example:

UA...: μA..., UPA...: μPA..., UPC...: μPC,

UPD...: μPD...

The components identified by shading and mark △ are critical for safety. Replace only with part number specified.

## ELECTRICAL PARTS

Ref.No.	Part No.	Description			
R719	1-247-863-00	CARBON	22K	5%	1/6W
R720	1-214-760-00	METAL	20K	1%	1/4W
R721	1-214-753-00	METAL	10K	1%	1/4W
R722	1-214-760-00	METAL	20K	1%	1/4W
R723	1-214-753-00	METAL	10K	1%	1/4W
R724	1-214-760-00	METAL	20K	1%	1/4W
R725	1-214-753-00	METAL	10K	1%	1/4W
R726	1-214-760-00	METAL	20K	1%	1/4W
R727	1-214-753-00	METAL	10K	1%	1/4W
R728	1-214-760-00	METAL	20K	1%	1/4W
R729	1-214-753-00	METAL	10K	1%	1/4W
R730	1-214-760-00	METAL	20K	1%	1/4W
R731	1-214-760-00	METAL	20K	1%	1/4W
R732	1-247-883-00	CARBON	150K	5%	1/6W
R733	1-247-877-00	CARBON	82K	5%	1/6W
R734	1-247-897-00	CARBON	560K	5%	1/6W
R735	1-246-489-00	CARBON	4.7K	5%	1/4W
R736	1-247-903-00	CARBON	1M	5%	1/6W
R737	1-247-849-00	CARBON	5.6K	5%	1/6W
R738	1-247-849-00	CARBON	5.6K	5%	1/6W
R739	1-247-849-00	CARBON	5.6K	5%	1/6W
R740	1-247-849-00	CARBON	5.6K	5%	1/6W
R741	1-247-849-00	CARBON	5.6K	5%	1/6W
R742	1-246-455-00	CARBON	180	5%	1/4W
R743	1-246-455-00	CARBON	180	5%	1/4W
R744	1-246-455-00	CARBON	180	5%	1/4W
R745	1-246-455-00	CARBON	180	5%	1/4W
R746	1-246-455-00	CARBON	180	5%	1/4W
R748	1-206-463-00	METAL OXIDE	10	5%	2W
R749	1-247-863-00	CARBON	22K	5%	1/6W
R750	1-244-875-00	CARBON	1.2K	5%	1/2W
R751	1-247-831-00	CARBON	1K	5%	1/6W
R752	1-206-447-00	METAL OXIDE	2.2	5%	2W
R753	1-247-863-00	CARBON	22K	5%	1/6W
R754	1-244-875-00	CARBON	1.2K	5%	1/2W
R755	1-247-831-00	CARBON	1K	5%	1/6W
R756	1-246-471-00	CARBON	820	5%	1/4W
R757	1-247-843-00	CARBON	3.3K	5%	1/6W
R758	1-247-849-00	CARBON	5.6K	5%	1/6W
R759	1-244-879-00	CARBON	1.8K	5%	1/2W
R760	1-247-863-00	CARBON	22K	5%	1/6W
R761	1-247-843-00	CARBON	3.3K	5%	1/6W
R762	1-247-849-00	CARBON	5.6K	5%	1/6W
R763	1-244-879-00	CARBON	1.8K	5%	1/2W
R764	1-247-863-00	CARBON	22K	5%	1/6W

## ELECTRICAL PARTS

Ref.No.	Part No.	Description			
R765	1-247-863-00	CARBON	22K	5%	1/6W
R766	1-247-863-00	CARBON	22K	5%	1/6W
R767	1-247-849-00	CARBON	5.6K	5%	1/6W
R768	1-247-849-00	CARBON	5.6K	5%	1/6W
R769	1-247-849-00	CARBON	5.6K	5%	1/6W
R770	1-247-849-00	CARBON	5.6K	5%	1/6W
R771	1-247-849-00	CARBON	5.6K	5%	1/6W
R772	1-247-849-00	CARBON	5.6K	5%	1/6W
R777	1-247-843-00	CARBON	3.3K	5%	1/6W
R778	1-247-843-00	CARBON	3.3K	5%	1/6W
R779	1-247-843-00	CARBON	3.3K	5%	1/6W
R780	1-247-843-00	CARBON	3.3K	5%	1/6W
R781	1-247-843-00	CARBON	3.3K	5%	1/6W
R782	1-247-843-00	CARBON	3.3K	5%	1/6W
R783	1-247-849-00	CARBON	5.6K	5%	1/6W
R784	1-247-849-00	CARBON	5.6K	5%	1/6W
R785	1-247-863-00	CARBON	22K	5%	1/6W
R786	1-247-863-00	CARBON	22K	5%	1/6W
R787	1-247-863-00	CARBON	22K	5%	1/6W
R788	1-247-863-00	CARBON	22K	5%	1/6W
R789	1-247-843-00	CARBON	3.3K	5%	1/6W
R790	1-247-843-00	CARBON	3.3K	5%	1/6W
R791	1-247-843-00	CARBON	3.3K	5%	1/6W
R792	1-247-843-00	CARBON	3.3K	5%	1/6W
R793	1-247-849-00	CARBON	5.6K	5%	1/6W
R794	1-247-849-00	CARBON	5.6K	5%	1/6W
R795	1-247-849-00	CARBON	5.6K	5%	1/6W
R796	1-247-855-00	CARBON	10K	5%	1/6W
R797	1-247-849-00	CARBON	5.6K	5%	1/6W
R798	1-247-847-00	CARBON	4.7K	5%	1/6W
R799	1-247-855-00	CARBON	10K	5%	1/6W
R801	1-247-863-00	CARBON	22K	5%	1/6W
R802	1-247-855-00	CARBON	10K	5%	1/6W
R803	1-247-862-00	CARBON	20K	5%	1/6W
R804	1-247-855-00	CARBON	10K	5%	1/6W
R805	1-247-863-00	CARBON	22K	5%	1/6W
R806	1-247-855-00	CARBON	10K	5%	1/6W
R807	1-247-879-00	CARBON	100K	5%	1/6W
R808	1-247-871-00	CARBON	47K	5%	1/6W
R809	1-247-831-00	CARBON	1K	5%	1/6W
R810	1-247-831-00	CARBON	1K	5%	1/6W
R811	1-247-839-00	CARBON	2.2K	5%	1/6W
R812	1-247-839-00	CARBON	2.2K	5%	1/6W
R813	1-247-831-00	CARBON	1K	5%	1/6W
R814	1-247-824-00	CARBON	510	5%	1/6W

### NOTE:

- Items with no part number and no description are not stocked because they are seldom required for routine service.
- Items marked with "▲" are not stocked since they are seldom required for routine service. Some delay should be anticipated when ordering these items.
- Due to standardization, parts with part numbers (Δ-ΔΔΔ-ΔΔΔ-XX or Δ-ΔΔΔΔ-ΔΔΔ-X) may be different from those used in the set.
- If there are two or more same circuits in a set such as a stereophonic machine, only typical circuit parts may be indicated and capacitors and resistors in other same circuits may be omitted.

### CAPACITORS:

MF:μF, PF:μμF.

### RESISTORS

All resistors are in ohms.

F : nonflammable

### COILS

MMH : mH, UH : μH

### SEMICONDUCTORS

In each case, U : μ, for example:

UA...: μA..., UPA...: μPA..., UPC...: μPC,

UPD...: μPD...

The components identified by shading and mark ▲ are critical for safety. Replace only with part number specified.

ELECTRICAL PARTS

Ref.No.	Part No.	Description			
R815	1-247-831-00	CARBON	1K	5%	1/6W
R816	1-247-849-00	CARBON	5.6K	5%	1/6W
R817	1-247-849-00	CARBON	5.6K	5%	1/6W
R818	1-247-849-00	CARBON	5.6K	5%	1/6W
R819	1-247-849-00	CARBON	5.6K	5%	1/6W
R820	1-247-849-00	CARBON	5.6K	5%	1/6W
R821	1-247-849-00	CARBON	5.6K	5%	1/6W
R822	1-247-849-00	CARBON	5.6K	5%	1/6W
R823	1-247-849-00	CARBON	5.6K	5%	1/6W
R824	1-247-821-00	CARBON	390	5%	1/6W
R825	1-247-883-00	CARBON	150K	5%	1/6W
R826	1-247-883-00	CARBON	150K	5%	1/6W
R827	1-247-883-00	CARBON	150K	5%	1/6W
R828	1-247-883-00	CARBON	150K	5%	1/6W
R829	1-247-843-00	CARBON	3.3K	5%	1/6W
R830	1-247-843-00	CARBON	3.3K	5%	1/6W
R831	1-247-843-00	CARBON	3.3K	5%	1/6W
R832	1-247-843-00	CARBON	3.3K	5%	1/6W
R833	1-247-843-00	CARBON	3.3K	5%	1/6W
R834	1-247-843-00	CARBON	3.3K	5%	1/6W
R835	1-247-843-00	CARBON	3.3K	5%	1/6W
R836	1-247-843-00	CARBON	3.3K	5%	1/6W
R842	1-217-428-00	FUSIBLE	3.3	5%	1/2W F
R843	1-244-891-00	CARBON	5.6K	5%	1/2W
R844	1-202-852-00	SOLID	4.7		1/4W F
RV001	1-226-938-00	RES, ADJ, METAL GLAZE	100K		
RV002	1-226-427-00	RES, ADJ, CARBON	500		
RV003	1-226-427-00	RES, ADJ, CARBON	500		
RV004	1-226-434-00	RES, ADJ, CARBON	100K		
RV005	1-226-434-00	RES, ADJ, CARBON	100K		
RV006	1-226-429-00	RES, ADJ, CARBON	2K		
RV007	1-226-429-00	RES, ADJ, CARBON	2K		
RV008	1-226-429-00	RES, ADJ, CARBON	2K		
RV009	1-226-429-00	RES, ADJ, CARBON	2K		
RV010	1-226-434-00	RES, ADJ, CARBON	100K		
RV011	1-226-434-00	RES, ADJ, CARBON	100K		
RV012	1-226-434-00	RES, ADJ, CARBON	100K		
RV013	1-226-434-00	RES, ADJ, CARBON	100K		
RV014	1-226-428-00	RES, ADJ, CARBON	1K		
RV015	1-226-431-00	RES, ADJ, CARBON	10K		
RV016	1-226-431-00	RES, ADJ, CARBON	10K		
RV017	1-226-431-00	RES, ADJ, CARBON	10K		
RV018	1-226-431-00	RES, ADJ, CARBON	10K		
RV101	1-224-247-XX	RES, ADJ, METAL GLAZE	100		
RV102	1-224-252-XX	RES, ADJ, METAL GLAZE	10K		
RV201	1-224-247-XX	RES, ADJ, METAL GLAZE	100		

ELECTRICAL PARTS

Ref.No.	Part No.	Description
RV202	1-224-252-XX	RES, ADJ, METAL GLAZE 10K
RV301	1-226-560-00	RES, VAR, CARBON 5K
RV302	1-224-251-XX	RES, ADJ, METAL GLAZE 4.7K
RV303	1-226-236-00	RES, ADJ, CARBON 10K
RV401	1-226-560-00	RES, VAR, CARBON 5K
RV402	1-224-251-XX	RES, ADJ, METAL GLAZE 4.7K
RV403	1-226-236-00	RES, ADJ, CARBON 10K
RV501	1-228-809-00	RES, VAR, CARBON 50K/50K
RV502	1-226-560-00	RES, VAR, CARBON 5K
RV504	1-226-980-00	RES, VAR, CARBON 20K/20K
RV701	1-226-236-00	RES, ADJ, CARBON 10K
RY001	1-515-473-00	RELAY
RY501	1-515-323-00	RELAY
S001	1-553-325-00	SWITCH
S002	1-554-205-00	SWITCH, PUSH
S003	1-554-205-00	SWITCH, PUSH
S301	1-554-290-00	SWITCH, PUSH (7 KEY)
S501	1-553-856-00	SWITCH, KEY BOARD
S601	1-553-856-00	SWITCH, KEY BOARD
S602	1-553-856-00	SWITCH, KEY BOARD
S701	1-553-318-00	SWITCH, PUSH (AC POWER)
S702	1-553-206-00	SWITCH, SLIDE
S703	1-553-856-00	SWITCH, KEY BOARD
S704	1-553-856-00	SWITCH, KEY BOARD
S705	1-553-856-00	SWITCH, KEY BOARD
S706	1-553-856-00	SWITCH, KEY BOARD
S707	1-553-856-00	SWITCH, KEY BOARD
S708	1-553-856-00	SWITCH, KEY BOARD
S709	1-553-856-00	SWITCH, KEY BOARD
T501	1-464-239-00	OSCILLATION UNIT, BIAS
TP001	1-508-879-00	BASE POST 4P
TP002	1-560-603-00	PIN, CONNECTOR 4P
TP701	1-560-062-00	PIN, CONNECTOR 4P
X001	1-567-082-00	VIBRATOR, CRYSTAL
X701	1-527-802-00	OSCILLATOR, CERAMIC

NOTE:

- Items with no part number and no description are not stocked because they are seldom required for routine service.
- Items marked "▲" are not stocked since they are seldom required for routine service. Some delay should be anticipated when ordering these items.
- Due to standardization, parts with part numbers (Δ-ΔΔΔ-ΔΔΔ-XX or Δ-ΔΔΔΔ-ΔΔΔ-X) may be different from those used in the set.
- If there are two or more same circuits in a set such as a stereophonic machine, only typical circuit parts may be indicated and capacitors and resistors in other same circuits may be omitted.

CAPACITORS:

MF:μF, PF:μuF.

RESISTORS

- All resistors are in ohms.
- F : nonflammable

COILS

- MMH : mH, UH : μH

SEMICONDUCTORS

In each case, U : μ, for example:  
 UA.... : μA...., UPA.... : μPA...., UPC.... : μPC,  
 UPD.... : μPD....

The components identified by shading and mark ▲ are critical for safety. Replace only with part number specified.

## TROUBLE CHECKS

The following trouble checks will help you correct the most common problems encountered with a tape deck. Should any problem persist after you have made these checks, consult your nearest Sony service facility.

Before proceeding with these trouble checks, first check these basic points:

- The power cord must be firmly connected.
- Amplifier connections must be firmly made.
- Heads, capstans and pinch-rollers should be clean.
- The amplifier controls and switches should be set correctly.

### FUNCTION BUTTONS AND TAPE TRANSPORT PROBLEMS

**The function buttons do not activate right after the POWER switch is turned on.**

- Logic-controlled function buttons operate approximately 4 seconds after the POWER switch is turned on.

**Recording or playback begins as soon as the POWER switch is turned on.**

- The TIMER switch is set at either REC or PLAY.

**The ● REC button and the ► button do not activate.**

- The cassette holder is not fully closed.

**The ● REC button does not activate.**

- No cassette in the holder.
- The tab has been removed from the cassette.

**The automatic shut-off mechanism activates before the end of the tape.**

- The tape is slack.
- The memory counter function is in operation.
- This situation may also be caused by a deformed cassette shell.

**Tape transport noise seems excessively loud in rewind or fast-forward mode.**

- This situation depends upon the cassette used and is not a problem.

### RECORDING AND PLAYBACK PROBLEMS

**Recording or playback cannot be made or there is a decrease in sound level.**

- Contamination or magnetic build-up on the record and playback heads.
- Improper connection.
- Improper setting of the amplifier controls.
- The tape is played back with the MONITOR switch set to SOURCE.

**Excessive wow or flutter or drop out**

- Contamination of the capstans or pinch rollers.

**Incomplete erasure**

- Contamination of the erase head.

**Increase of noise or erasure of high frequencies**

- Magnetic build-up on the heads.

**Unbalanced tone in higher frequencies**

- Improper setting of the DOLBY NR switches. When playing back, set the switches to the same position used in recording.
- Improper setting of the TAPE select buttons. If recorded with the wrong button pressed, adjust the tone controls of the amplifier in playback.

### NOISE

**Hum noise**

- The tape deck is stacked on or under the amplifier. Separate the units.