

# TC-K570 / K670 / K677ES

## SERVICE MANUAL

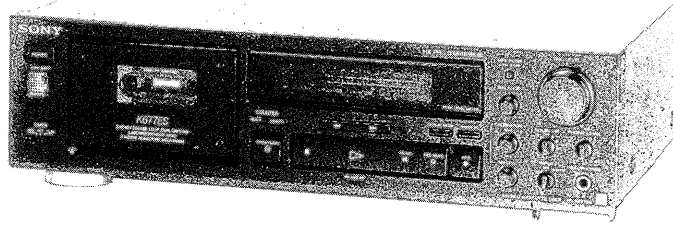

Photo: TC-K677ES

Canadian Model  
AEP Model  
UK Model  
E Model  
TC-K570

US Model  
AEP Model  
TC-K670

US Model  
Canadian Model  
UK Model  
TC-K677ES

### SPECIFICATIONS

Recording system 4-track 2-channel stereo  
Fast-winding time Approx. 90 sec. (with Sony C-60 cassette)  
Bias AC bias  
Heads Erasing head × 1 (S&F head)  
Recording head × 1 (Permalloy head)  
Playback head × 1 (LA head)  
Motors Capstan motor × 1 (DC servo motor)  
Reel motor × 1 (DC motor)  
ASIST(mechanical drive) motor × 1 (DC motor)

Signal-to-noise ratio (at peak level)

Cassette	Dolby NR switch		
	OFF	B-Type ON	C-Type ON
Type IV(Sony METAL-SLT/S)	60dB	69 dB	75 dB
Type II(Sony UX-S)	59 dB	68 dB	74 dB
Type I(Sony HF-S)	57 dB	66 dB	72 dB

Total harmonic distortion 1.0% (with Sony METAL-SLT/S cassette)

Frequency response (DOLBY NR OFF)

Type IV cassette (Sony METAL-SLT/S)	20-21,000 Hz (±3 dB, IEC) 20-16,000 Hz [±3 dB 0VU (-4dB) recording]
Type II cassette (Sony UX-S)	20-19,000 Hz (±3 dB, IEC)
Type I cassette (Sony HF-S)	20-17,000 Hz (±3 dB, IEC)

Wow and flutter ±0.09% W.Peak (IEC)  
0.05% WRMS (NAB)  
±0.14% W.Peak (DIN)

Model Name Using Similar Mechanism	TC-K620/K650ES	
Tape Transport Mechanism Type	TC-K570	TCM-200V7
	TC-K670	TCM-200V5
	TC-K677ES	TCM-200V4

#### Inputs

Line inputs (phono jacks)	Sensitivity	77.5 mV
	Input impedance	47 k ohms
CD DIRECT INPUT	Input impedance	47 k ohms

#### Outputs

Line outputs (phono jacks)	Rated output level	0.32 V at a load impedance of 47 k ohms
	Load impedance	Over 10 k ohms
Headphones (stereo phone jack)	Output level	0-1.25 mW at a load impedance of 32 ohms

#### General

Power requirements US, Canadian model: TC-K570: 120V AC 60Hz 18W  
TC-K670, K677ES: 120V AC 60Hz 19W  
AEP, Germany model: 220VAC~50/60Hz  
UK model: 240VAC~50/60Hz  
E model: 120, 220, 240V AC~50/60Hz 18W

Power consumption 19 W

Dimensions Approx. 430 × 123 × 300 mm (w/h/d)  
(17 × 4<sup>7</sup>/<sub>8</sub> × 11<sup>7</sup>/<sub>8</sub> inches)

Weight Approx. 4.9 kg (10 lbs 13 oz)  
including projecting parts and controls

#### Supplied accessories

Audio connecting cords (2)

Design and specifications subject to change without notice.

#### Note

This appliance conforms with EEC Directive 87/308/EEC regarding interference suppression.

STEREO CASSETTE DECK  
**SONY**®



Dolby noise reduction manufactured under license from Dolby Laboratories Licensing Corporation.  
"DOLBY" and the double-D symbol  are trademarks of Dolby Laboratories Licensing Corporation.

## SAFETY CHECK-OUT

After correcting the original service problem, perform the following safety check before releasing the set to the customer:

Check the antenna terminals, metal trim, "metallized" knobs, screws, and all other exposed metal parts for AC leakage. Check leakage as described below.

### LEAKAGE TEST

The AC leakage from any exposed metal part to earth ground and from all exposed metal parts to any exposed metal part having a return to chassis, must not exceed 0.5 mA (500 microamperes). Leakage current can be measured by any one of three methods.

1. A commercial leakage tester, such as the Simpson 229 or RCA WT-540A. Follow the manufacturers' instructions to use these instruments.
2. A battery-operated AC milliammeter. The Data Precision 245 digital multimeter is suitable for this job.
3. Measuring the voltage drop across a resistor by means of a VOM or battery-operated AC voltmeter. The "limit" indication is 0.75 V, so analog meters must have an accurate low-voltage scale. The Simpson 250 and Sanwa SH-63Trd are examples of a passive VOM that is suitable. Nearly all battery operated digital multimeters that have a 2V AC range are suitable. (See Fig. A)

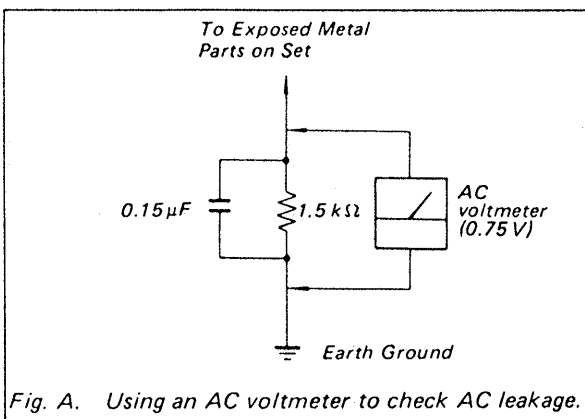

#### SAFETY-RELATED COMPONENT WARNING!!

COMPONENTS IDENTIFIED BY MARK  $\triangle$  OR DOTTED LINE WITH MARK  $\triangle$  ON THE SCHEMATIC DIAGRAMS AND IN THE PARTS LIST ARE CRITICAL TO SAFE OPERATION. REPLACE THESE COMPONENTS WITH SONY PARTS WHOSE PART NUMBERS APPEAR AS SHOWN IN THIS MANUAL OR IN SUPPLEMENTS PUBLISHED BY SONY.

## TABLE OF CONTENTS

<u>Section</u>	<u>Title</u>	<u>Page</u>
SECTION 1.	GENERAL . . . . .	3
SECTION 2.	DISASSEMBLY . . . . .	4
SECTION 3.	PIN DESCRIPTION . . . . .	8
SECTION 4.	ADJUSTMENTS	
	4-1. Mechanical Adjustments . . . . .	9
	4-2. Electrical Adjustments . . . . .	12
SECTION 5.	DIAGRAMS	
	5-1. Printed Wiring Boards . . . . .	16
	5-2. Circuit Boards Location . . . . .	21
	5-3. Semiconductor Lead Layouts . . . . .	21
	5-4. Schematic Diagram	
	—Audio Section— . . . . .	22
	5-5. Schematic Diagram	
	—System Control Section— . . . . .	25
SECTION 6.	EXPLODED VIEWS	
	6-1. Chassis Section . . . . .	29
	6-2. Front Panel Section . . . . .	30
	6-3. Mechanism Section 1 . . . . .	31
	6-4. Mechanism Section 2 . . . . .	32
SECTION 7.	ELECTRICAL PARTS LIST . . . . .	33

### MODEL IDENTIFICATION

— Specification Label —

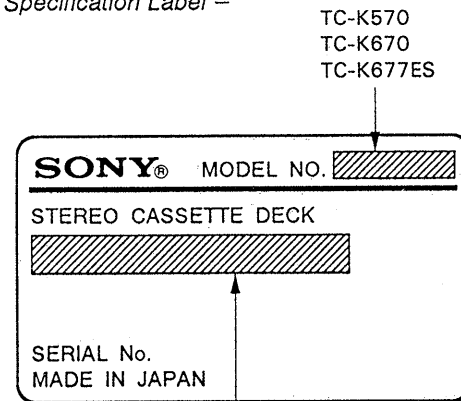

US, Canadian model: TC-K570: AC120V 60Hz 18W  
TC-K670, K677ES: AC120V 60Hz 19W  
AEP, Germany model: AC220V~50/60Hz  
UK model: AC240V~50/60Hz  
E model: AC120, 220, 240V~50/60Hz 18W

#### ATTENTION AU COMPOSANT AYANT RAPPORT À LA SÉCURITÉ!

LES COMPOSANTS IDENTIFIÉS PAR UNE MARQUE  $\triangle$  SUR LES DIAGRAMMES SCHÉMATIQUES ET LA LISTE DES PIÈCES SONT CRITIQUES POUR LA SÉCURITÉ DE FONCTIONNEMENT. NE REMPLACER CES COMPOSANTS QUE PAR DES PIÈCES SONY DONT LES NUMÉROS SONT DONNÉS DANS CE MANUEL OU DANS LES SUPPLÉMENTS PUBLIÉS PAR SONY.

## SECTION 1 GENERAL

This section is extracted  
from instruction manual.

### Identification of Front Panel Parts

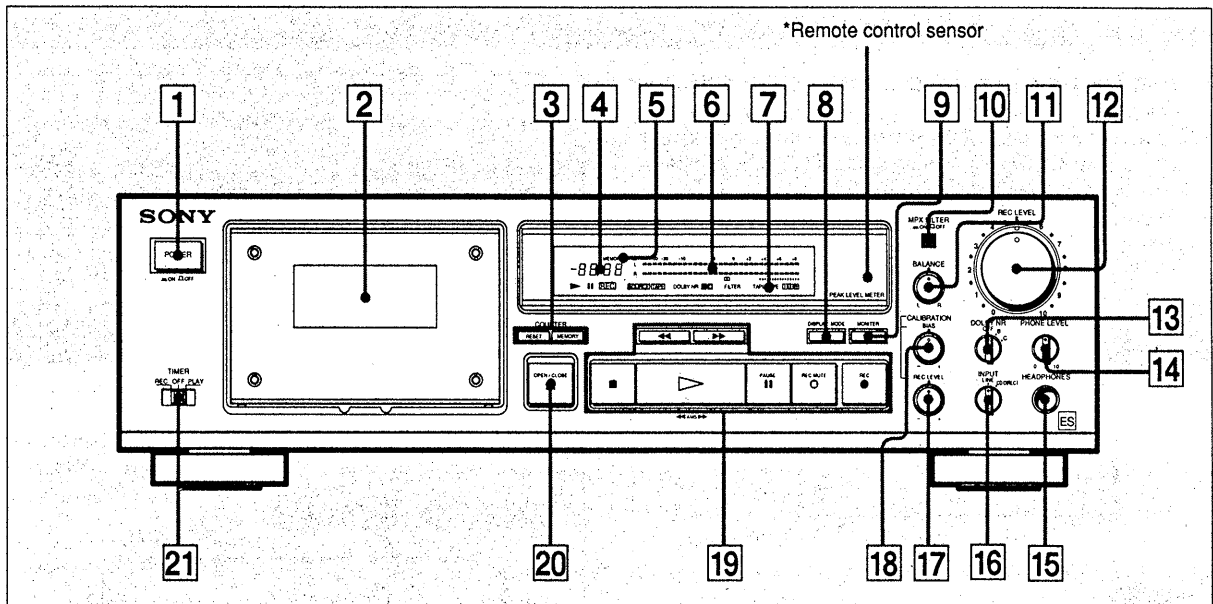



For details, refer to the page number indicated in ●.

- |  |   |
|--|---|
| <p>1 POWER switch</p> <p>2 Cassette holder</p> <p>3 Counter buttons<br/>RESET button ●<br/>MEMORY button ●</p> <p>4 LINEAR COUNTER ●</p> <p>5 MEMORY indicator ●</p> <p>6 PEAK LEVEL METER ●</p> <p>7 TAPE TYPE indicator ●</p> <p>8 DISPLAY MODE button ●</p> <p>9 MONITOR button ●</p> <p>10 MPX FILTER switch ●</p> <p>11 BALANCE control ●</p> <p>12 REC (recording) LEVEL control ● ●</p> <p>13 DOLBY NR (noise reduction) switch ● ●</p> <p>14 PHONE (headphones) LEVEL control ●</p> <p>15 HEADPHONES jack (stereo phone jack) ●</p> <p>16 INPUT selector ●</p> | <p>17 REC (recording) LEVEL control for calibration ●</p> <p>18 BIAS control ●</p> <p>19 Tape operation buttons<br/>◀◀ (rewind) button<br/>▶▶ (fast-forward) button<br/>■ (stop) button<br/>▶ (play) button<br/>   PAUSE button<br/>○ REC MUTE (record muting) button ●<br/>● REC (recording) button</p> <p>20 ▲ OPEN/CLOSE button</p> <p>21 TIMER switch ●</p> |
|--|---|

#### \*Remote control sensor

You can remotely control this cassette deck with:

- A remote commander that came with a Sony amplifier or receiver if it has the  mark and cassette deck control capability.
- An optional Sony remote commander with the  mark and cassette deck control capability.

## SECTION 2 DISASSEMBLY

**Note:** Follow the disassembly procedure in the numerical order given.

### MECHANISM BLOCK

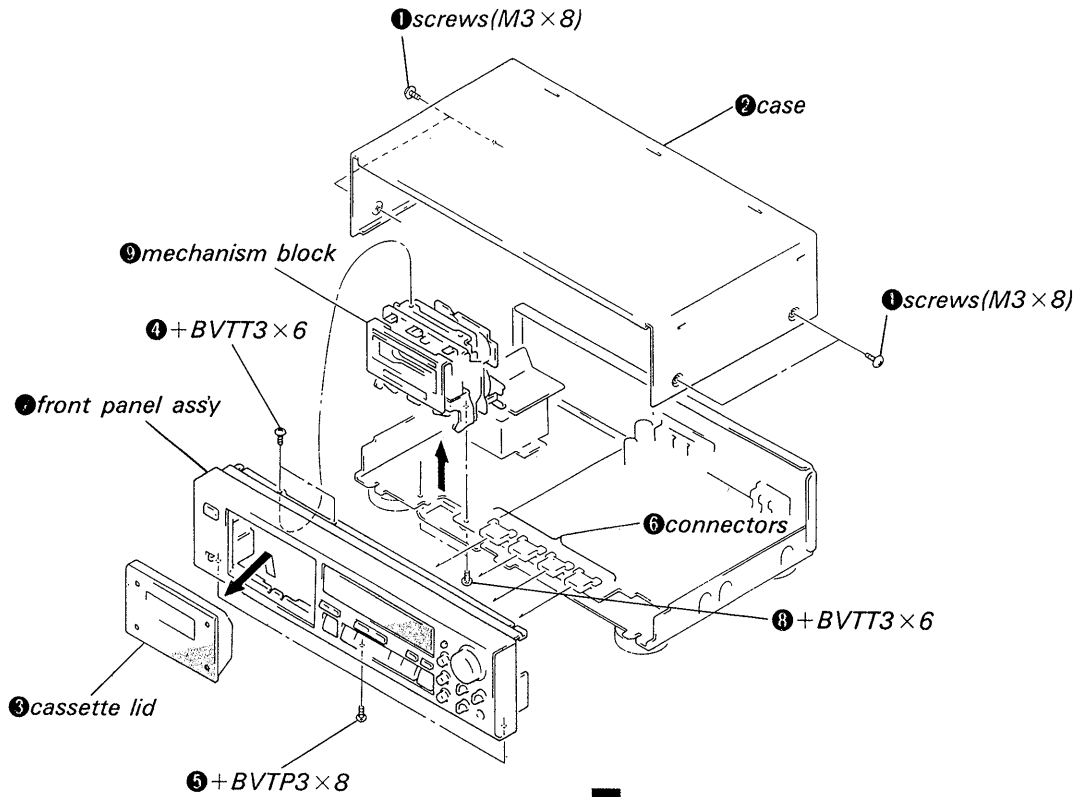

### CASSETTE HOLDER

③ Push lever (lifter) in the direction of arrow and remove cassette holder.

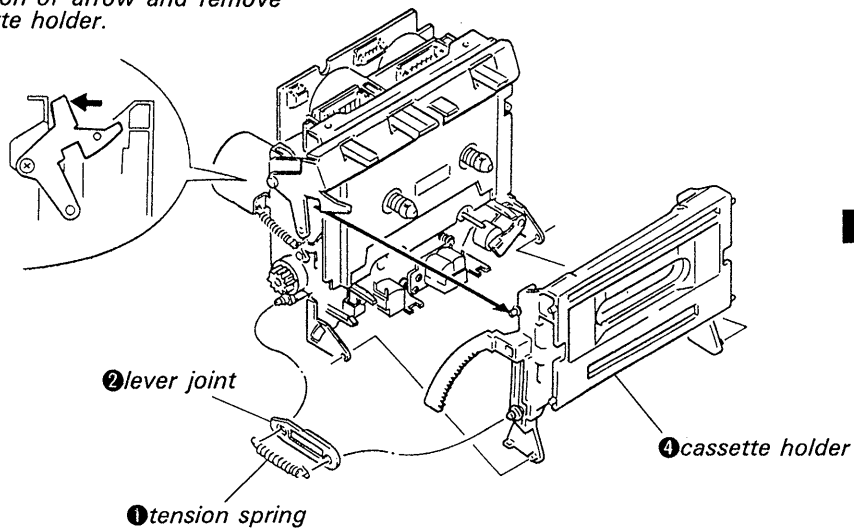

ORNAMENTAL PLATE

② Push lever (lifter) in the direction of arrow and remove ornamental plate.

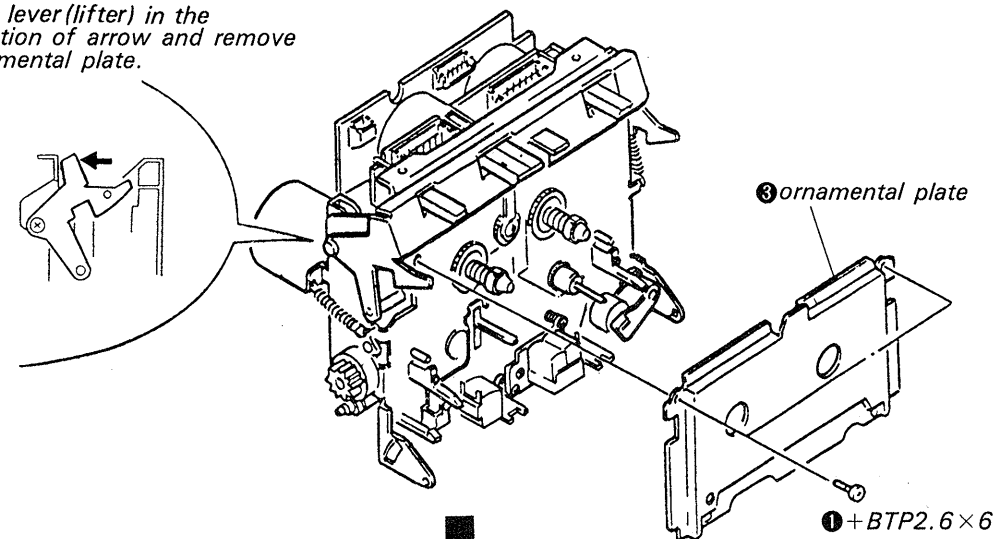

PINCH LEVER (TC-K570)

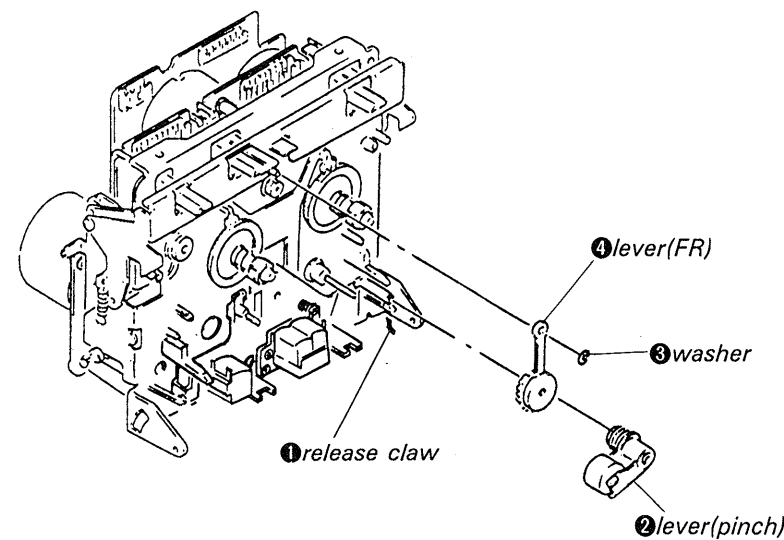

PINCH LEVER (TC-K670/K677ES)

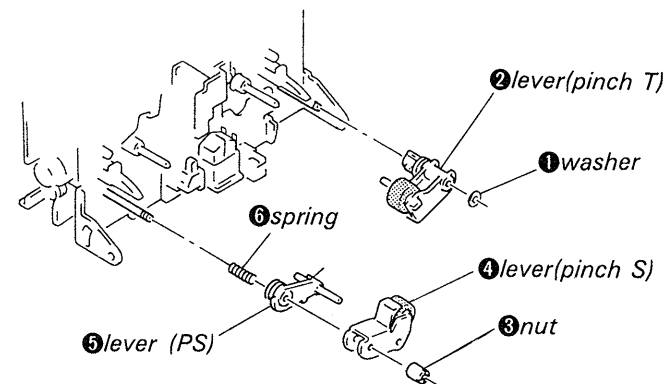

CAPSTAN MOTOR/FLYWHEEL (TC-K570)

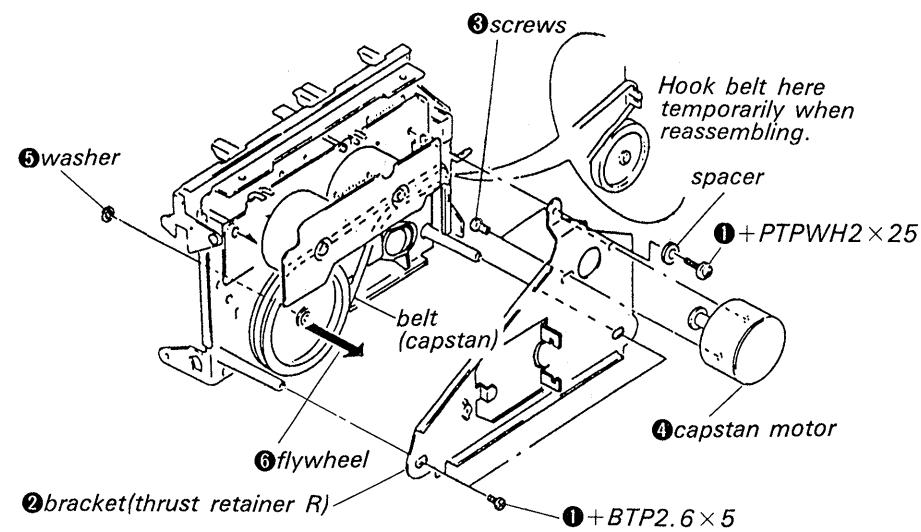

CAPSTAN MOTOR/FLYWHEEL (TC-K670/K677ES)

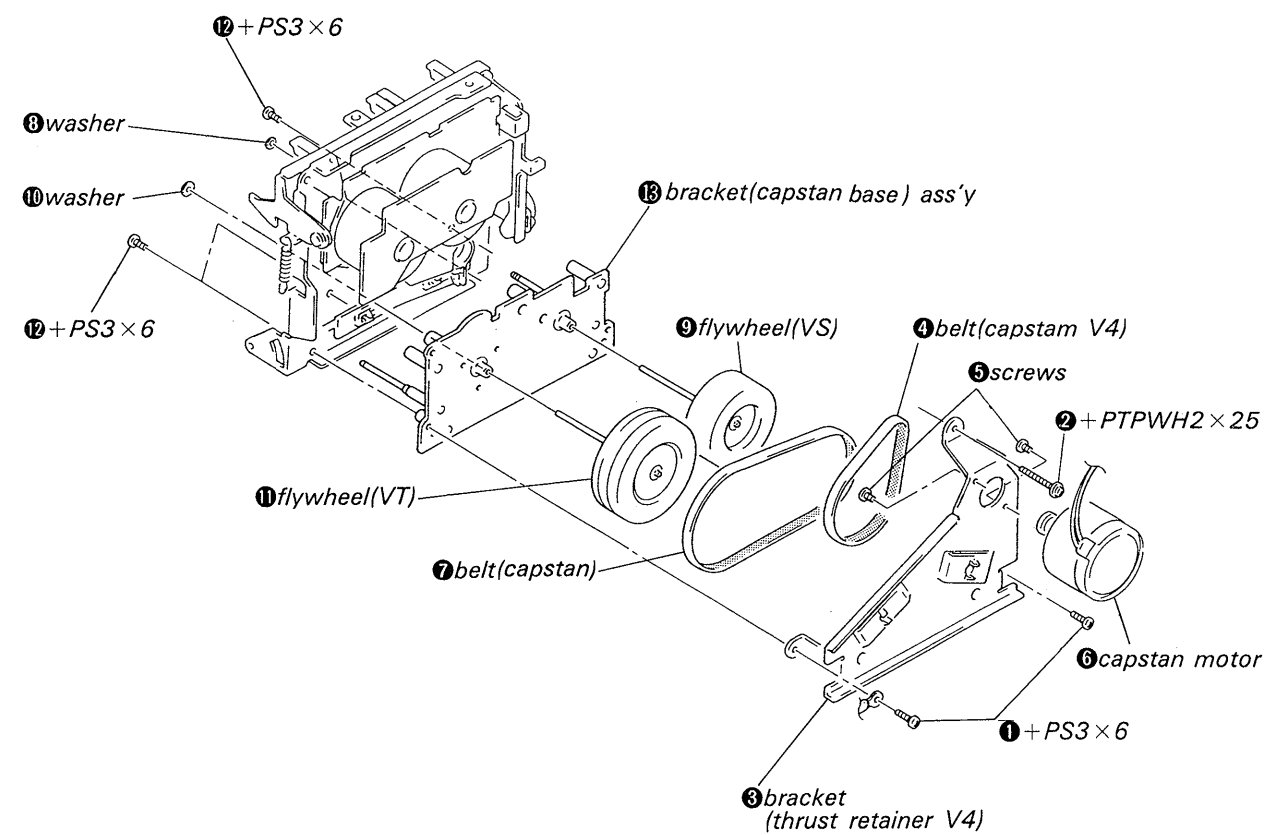

REEL AND ASSIST MOTORS

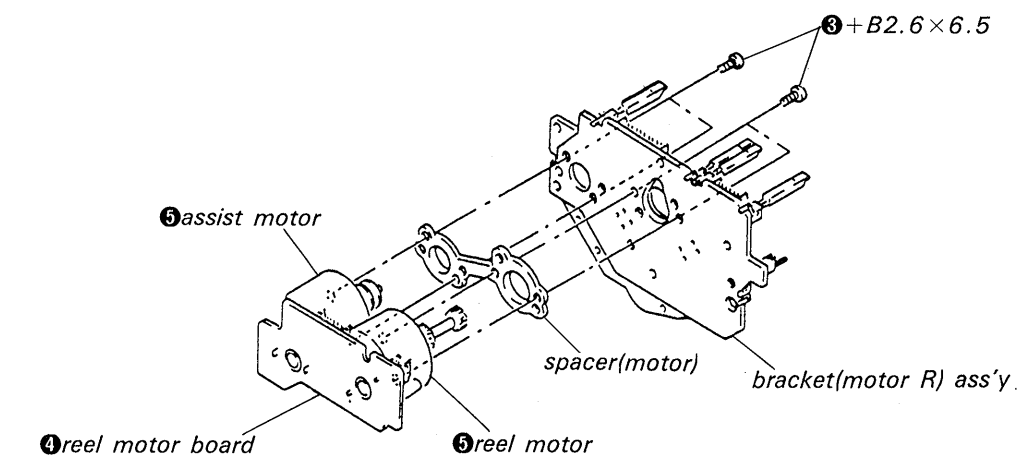
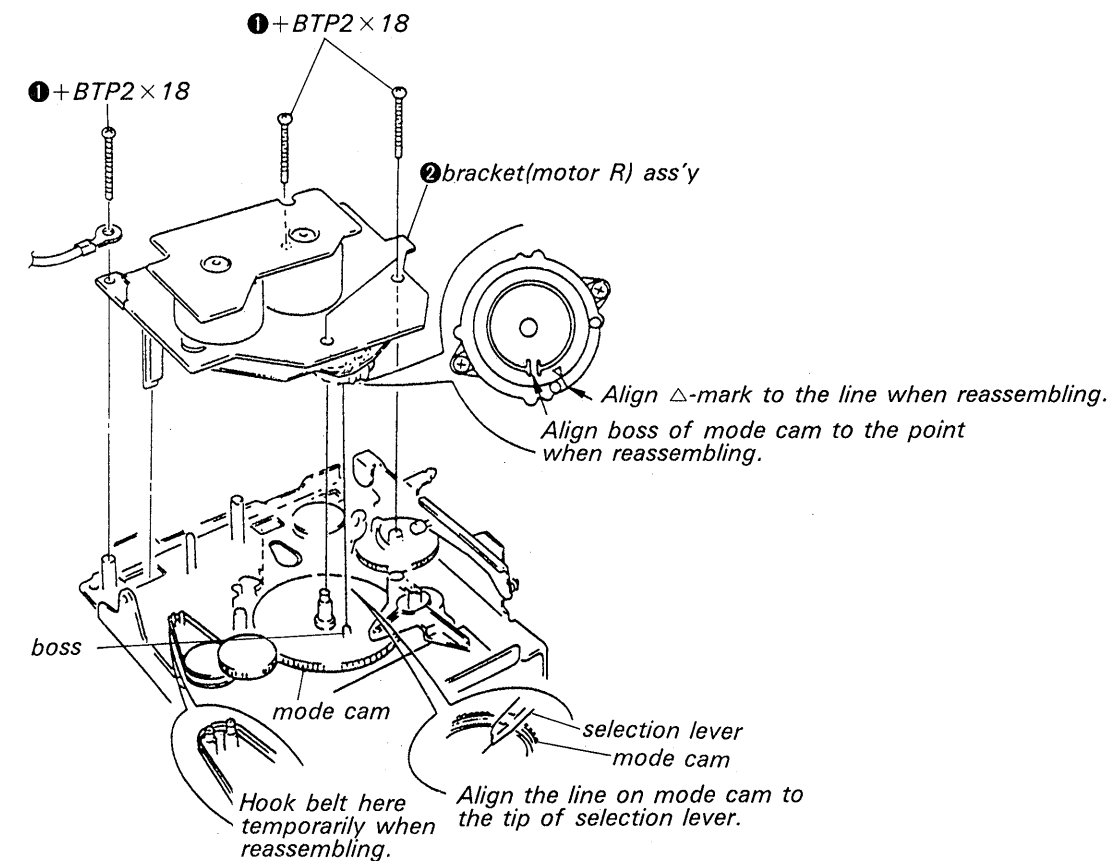

## SECTION 3 PIN DESCRIPTION

### ●IC701 M50941-483SP(MICRO COMPUTER)

The M50941-483SP function are described below.

Pin No.	Pin Name	I/O	Description
1	V <sub>REF</sub>	I	Internal A/D port reference voltage input.
2	KEY 7	I	Key input port. 0V = OPEN/CLOSE, 1V = STOP, 2V = REW, 3V = FF, 4V = REC.
3	KEY 6	I	key input port. 0V = PLAY, 1V = PAUSE, 2V = REC MUTE.
4	KEY 5	I	Key input port. 0V = RESET, 1V = MEMORY, 2V = DISPLAY MODE, 3V = MONITOR.
5	METER-L	I	Signal input for level meter-L.
6	METER-R	I	Signal input for level meter-R.
7	TIMER	I	Timer REC/PLAY switch input. 0V = TIMER REC, 1V = TIMER PLAY, 2V = OFF.
8	T. PULSE	I	Take-up reel base sensor input.
9	S. PULSE	I	Supply reel base sensor input.
10	AMS. SIG	I	AMS signal input. No song detected = Low. Song detected = High.
11	BIAS	O	Bias oscillation on and off control.
12	MO3V	O	Motor speed control. STOP/PLAY = Low, FF/REW = High.
13	MO4.5V	O	Motor speed control. STOP/PLAY = High, FF/REW = Low.
14	MO-FWD	O	Reel motor rotates.
15	MO-REV	O	Reel motor rotates in reverse.
16	MO-DOWN	O	Head base DOWN output of the mechanical block.
17	MO-UP	O	Head base UP output of the mechanical block.
18	HALF-SW	I	HALF switch input of the mechanical block.
19	REC-SW	I	REC switch input of the mechanical block.
20	DOOR-SW	I	DOOR switch input of the mechanical block.
21	CLOSE-SW	I	CLOSE switch input of the mechanical block.
22	OPEN-SW	I	OPEN switch input of the mechanical block.
23	POWER-OUT	O	"Low" for power off procedure after POWER switch is turned off.
24	POWER-IN	I	Power(AC) off detection.
25	SIRCS	I	Remote control signal input.
26	V <sub>ss</sub>	—	GND
27	RESET	I	System reset input.
28	XI	I	Clock input(4.19MHz).
29	XO	O	Clock output.
30	XCI	—	Not used.
31	XCO	—	Not used.
32	V <sub>ss</sub>	—	GND
33	—	—	Not used.
34	PAT3	I	
		I	Rotary encoder input to detect the position of the head base of the mechanical block.
37	PATO	I	
38	-25V	—	Power supply for driving the fluorescent indicator tube.
39	FL-p	O	
		I	Segment data output for the fluorescent indicator tube FL751.
54	FL-a	O	
55	FL-G5	O	
		I	Common data output for the fluorescent indicator tube FL751.
59	FL-G1	O	
60	MONITOR	O	Source monitor control. Low = TAPE, High = SOURCE.
61	REC-MUTE	O	REC MUTE control. Low = MUTE.
62	LINE-MUTE	O	LINE MUTE control. Low = MUTE.
63	AV <sub>cc</sub>	—	Analog power supply(+5V).
64	V <sub>cc</sub>	—	Power supply(+5V).

# SECTION 4 ADJUSTMENTS

## 1. MECHANICAL ADJUSTMENTS

### PRECAUTION

1. Clean the following parts with a denatured-alcohol-moistened swab:
 

record/playback head	pinch roller
erase head	rubber belts
capstan	idler
2. Demagnetize the record/playback head with a head demagnetizer.
3. Do not use a magnetized screwdriver for the adjustments.
4. After the adjustments, apply suitable locking compound to the parts adjusted.

### Tape Path Adjustment

**Note :** When using the adjustment methods for other than replacement reasons, please do not tamper unnecessarily with the adjustment screws or the erasehead because either the supply pinch roller guide or the record/playback head will be made the standard tape paths. Moreover, when it is necessary to adjust and replace two or more of any of the heads and/or pinch rollers, replace them one by one, completely taking out the first tape path, and then replacing the second one.

(TC-K670/K677ES)

### Preparation :

1. Mirror cassette CQ009C 8-909-708-01  
(or CQ012C 8-909-708-02)

If one does not have this, cut out the sections of a 120-minute cassette shell as indicated below and use that cassette.

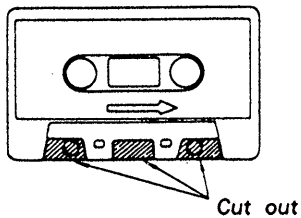

2. Phillips screwdriver (medium-size) :  
For the head adjustment screws  
Blade-type screwdriver (large-size) :  
For the supply pinch roller adjustment screws
3. Pen light
4. WS-48B (3 kHz, 0 dB)
5. P-4-A100 (10 kHz, -10 dB)

**Adjustment Position :** As seen from the cassette, side (top) and MD as seen head on (bottom).

TC-K670/K677ES

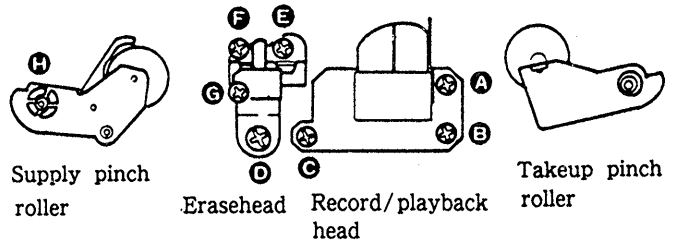
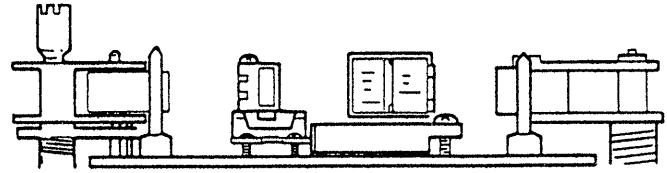

TC-K570

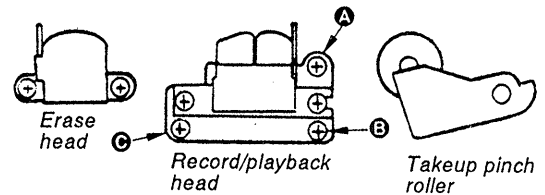
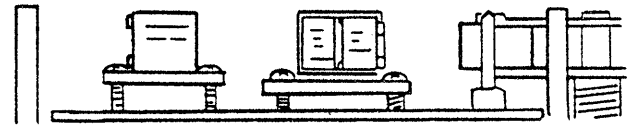

**Definition of Terms :** The figures are of a record/playback head.

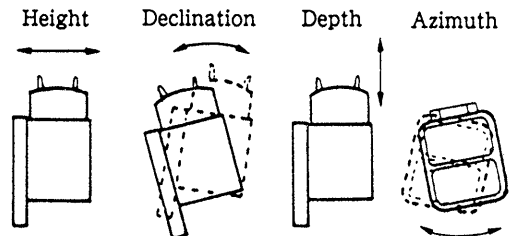

**Adjustment Method :**

**Supply Pinch Roller** : TC-K670/K677ES



**Note :** Only perform this adjustment when the supply pinch roller is to be replaced.

1. Insert the mirror cassette and put the unit in record/playback mode.
2. Check to see whether the tape is curling at the record/playback head guide or the pinch roller guide.

If it is curling, remove the curl by adjusting the  tape curl adjustment screw. Then, check that the tape is running past the middle of the erasehead.

**Record/playback Head**

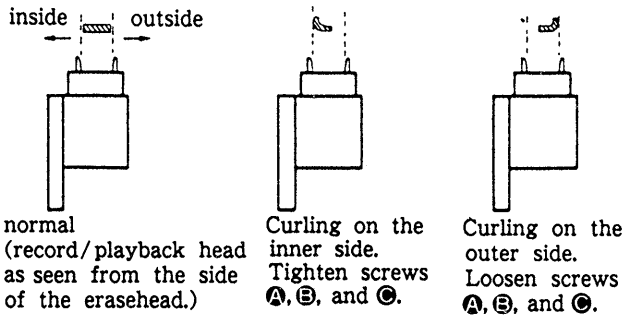

**Note :** Only perform this adjustment when the record /playback head is to be replaced.

1. Insert the mirror cassette and put the unit in record/playback mode.
2. **(Height Adjustment)** Check to see if the tape is curling at the tape guide of the head. If it is curling, tighten screws , , and , respectively by the same angle, moving the head so that it remains at the same angle throughout the procedure. If it curls on the bottom side of the mirror cassette (actually the inner side), tighten all the screws equally ; but loosen them if the tape begins to curl on the top side (outer side).



3. **(Declination Adjustment)** While in the record/playback position, set the back tension to 0 (wind the supply reel with something thin like a pencil in a counterclockwise direction) and make sure there is no curling or shifting (shifting up/shifting down) at the guide of the record/playback head.

Because shifting can only occur due to a difference in the width of the tape and that of the tape guides (curling will otherwise occur), it is necessary to pay close attention since it can be easily overlooked.

When there is a shift, tighten screws  and  equally and change the declination of the head. If the tape is shifting up, tighten the screws, and if it is shifting down, loosen them.

4. Repeat the adjustments in steps 2 and 3 and fine adjust the height and the declination.
5. **(Preliminary Azimuth Adjustment)**  
After demagnetizing and cleaning the adjustment head, play back WS-48B (3 kHz, 0 dB). Turn screw  so that the reading on the level meter of the unit or that of the level meter connected to LINE OUT is maximized. If the screw is turned at least half a revolution, repeat the adjustments from step 1.
6. **(Tape Path Check)** Connect the oscilloscope to LINE OUT and play back P-4-A100 (10 kHz, -10 dB) to display a resurge waveform. After 20 seconds of record/playback (after the tension within the loop has been increased sufficiently), make sure the variation in the resurge is within  $\pm 90$  degrees (within  $\pm 45$  degrees is desired). If the variation is greater than this, it is because the declination and/or the height adjustment is not perfect. Repeat the adjustments from step 1.

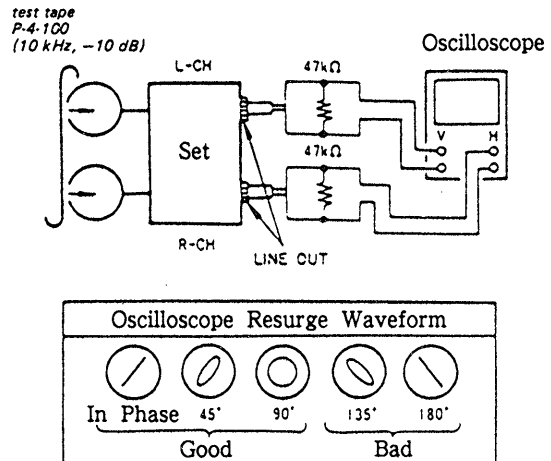



**Erasehead** : TC-K670/K677ES

**Note** : Only perform this adjustment when the erasehead is to be replaced.

1. Insert the mirror cassette and put the unit in record/playback mode.
2. (**Azimuth Adjustment**) Adjust the azimuth of the erasehead by adjusting screws **Ⓔ** and **Ⓕ** so that the tape runs as evenly as possible.

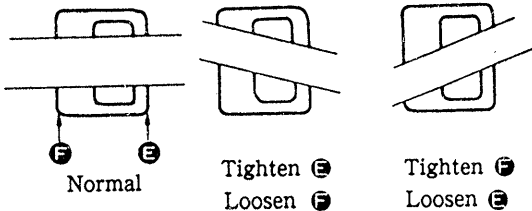

(The erasehead as seen when erasing the mirror cassette.)

3. (**Height adjustment**) Turn screws **Ⓓ**, **Ⓔ**, and **Ⓕ** all by the same angle so that the portions of the erasehead visible at top and bottom are nearly of equal width. If the width at the top is greater, tighten the screws ; if the width at the bottom is greater, loosen the screws.

Erasehead (The erasehead as seen through the mirror cassette.)

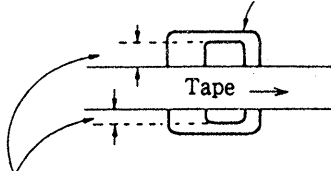

Make these the same width.

4. (**Declination Adjustment**) Leaving it in the playback position, put the back tension to 0 and make certain the erasehead part and supply pinch roller guide part do not shift. If there is a shift, turn the screw **Ⓓ** and change the declination. Looking at it using the mirror cassette, if the tape shifts up, tighten the screw, and if it shifts down, loosen the screw.
5. Repeat the adjustments beginning with step 2 and fine adjust the height and declination. And make sure the tape does not curl up on the pinch roller guide or the guide part of the record/playback head.
6. (**Depth Adjustment**) In order to make the entire head play the tape smoothly, and to make sure the depth of the erasehead is neither too shallow nor too deep, loosen screw **Ⓒ** a bit.

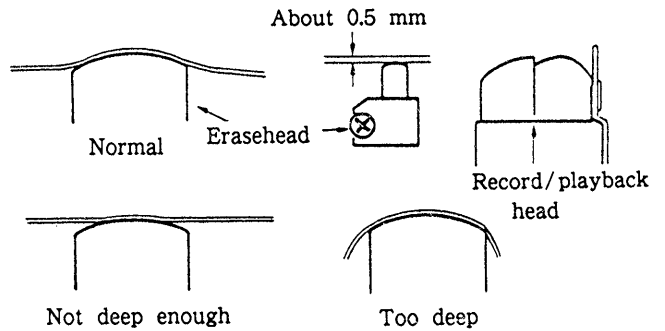

**Check**

1. Check to make sure that there are no curls or shifts throughout the whole tape path and that the tape runs smoothly.
2. Reapply the locking compound to the adjusted screws. (The locking compound should only be applied to screw **Ⓒ** after the azimuth has been adjusted.)

**TORQUE MEASUREMENT**

Torque	Torque meter	Meter reading
FWD	C Q-102C	28-60 g · cm(0.39-0.83 oz · inch)
FWD Back tension	C Q-102C	TC-K570:1-5 g · cm(0.014-0.069 oz · inch) TC-K670/K677ES:7-11 g · cm(0.097-0.15 oz · inch)
FF, REW	C Q-201B	85-90 g · cm(0.9-1.25 oz · inch)

**Pinch Roller Pressing Force Measurement**

Mode : playback

Hook needle of the tension gauge to the pinch roller shaft and push back pinch roller to detach it from capstan. Then, return it gradually to capstan and read the gauge when the pinch roller begins turning.

**Standard Limits :**

Tape-up side

TC-K570 : 210-320 g(7.4-11.3 oz)

TC-K670/K677ES : 270-350 g(9.5-120 oz)

Supply side

TC-K670/K677ES : 180-280 g(6.4-9.9 oz)

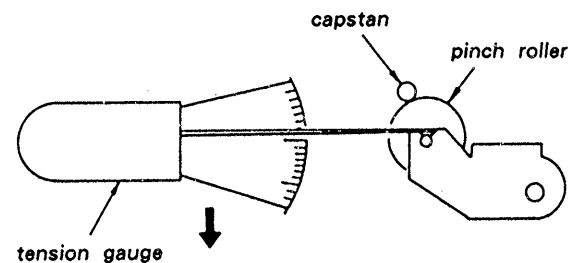

## 2. ELECTRICAL ADJUSTMENT

**Note:** The adjustment should be performed in the order given in the service manual. As a rule, adjustments about playback should be performed before those about recording.  
The adjustments should be performed before for both L-CH and R-CH.

- Switches and controls should be set as follows unless otherwise specified.
  - DOLBY NR switch: OFF
  - MPX FILTER switch: OFF
  - MONITOR switch: Tape
- Standard Record:
  - Deliver the standard input signal level to the input jack and set the REC LEVEL control to obtain the standard output signal level.

### — Record Mode —

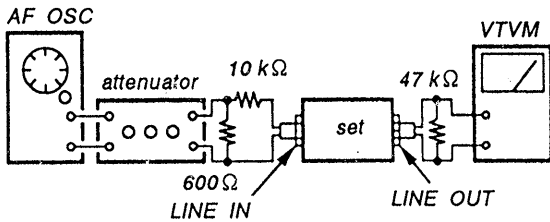

### Standard Input Level

input terminal	LINE IN
source impedance	10 kΩ
input level	0.25 V ( - 10 dB)

### Standard Output Level

output terminal	LINE OUT
load impedance	47 kΩ
output level	0.44V ( - 5 dB)

### Test Tape

Type	Signal	Used for
P-4-A100	10 kHz, - 10 dB	Azimuth Adjustment
P-4-L300	315 Hz, 0 dB	PB Level Adjustumet
WS-48B	3 kHz, 0 dB	Tape Speed Adjustment

### Test Mode

This set will get into test mode by shorting the pins of CNE707 (TEST) on MA I N (A) board before turning the power on.

### Record/Playback Head Azimuth Adjustment

#### Porcedure:

- Mode: FWD playback

Test tape  
P-4-A100  
(10 kHz, - 10 dB)

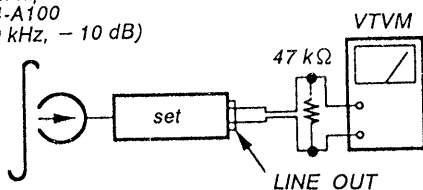

- Turn the adjustment screw for the maximum output levels. If these levels do not match, turn the adjustment screw until both of output levels match together within 1 dB.

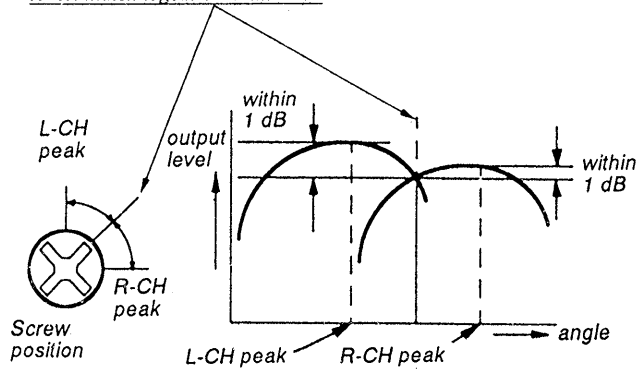

- Phase Check  
Mode: playback

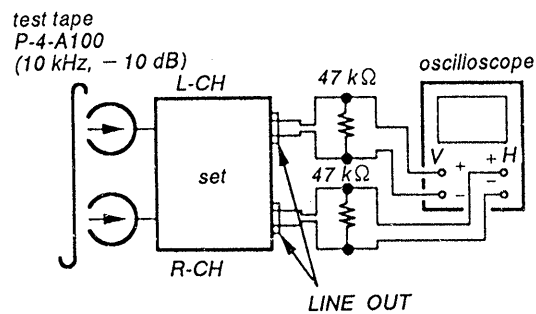

- After the adjustment, lock the screws with locking compound.

### Adjustment Location: Record/Playback head

TC-K570

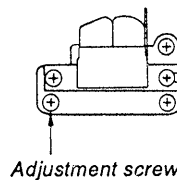

TC-K670/K677ES

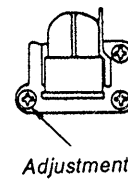

## Tape Speed Adjustment

### Setting:

Test pin CNE707: short

### Procedure:

Mode: playback

test tape  
WS-48B  
(3 kHz, 0 dB)

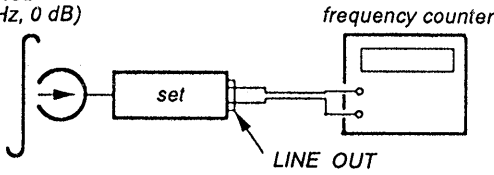

1. Set to FWD playback mode.
2. Adjust motor rear side (variable resistor) so that the frequency counter reading becomes  $3,000 \pm 15$  Hz.

**Adjustment Location:** motor rear side

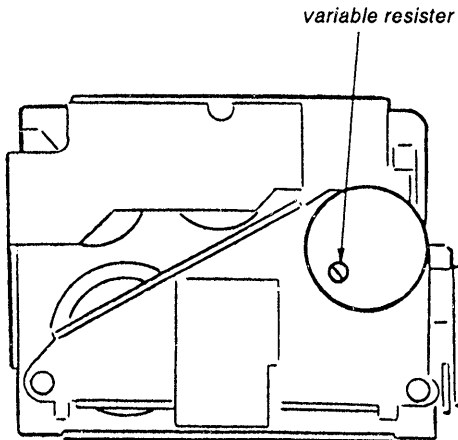

## Playback Level Adjustment

### Procedure:

Mode: playback

test tape  
P-4-L300  
(315 Hz, 0 dB)

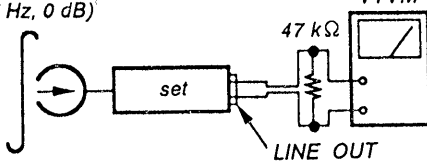

Adjust RV121 (L-ch) and RV221 (R-ch) so that the reading on VTVM meets the adjustment limits below.

### Adjustment Limits:

LINE OUT level:  $-5 \pm 0.5$  dB (0.41 – 0.46 V)

Level difference between channels: less than 0.5 dB

Check that the LINE OUT level does not change even if Playback and Stop operation is repeated several times.

**Adjustment Location:** MA I N (A) board

## Bias Consumption Current Adjustment

### Procedure:

LINE IN  
(no signal)

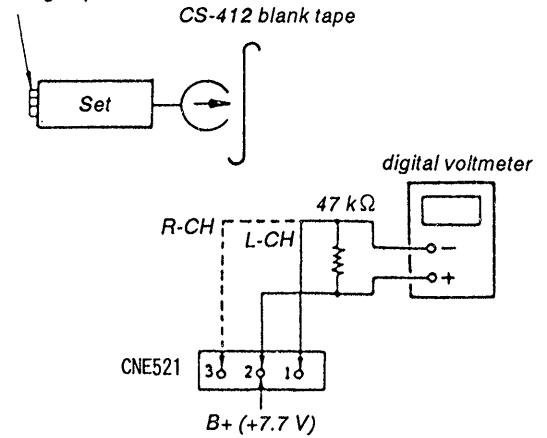

1. Set RV181 and RV281 to mechanical center and turn the set recording mode.
2. Connect digital voltmeter as shown by the following table.
3. Adjust the following transformers for the minimum readings on the digital voltmeter.

	Mesurement Point	Adjustment Part	Value
L-ch	① and ②, CNE521	T181	not more than
R-ch	③ and ② CNE521	T281	200mV

**Adjsutment Location:** MA I N (A) board

## Record Bias Adjustment

### Setting:

REC LEVEL control: Standard Record (see page 12).

test pin CNE707: short

### Procedure:

1. Mode: record

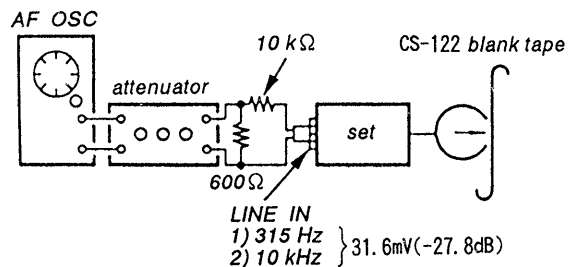

2. Mode: playback

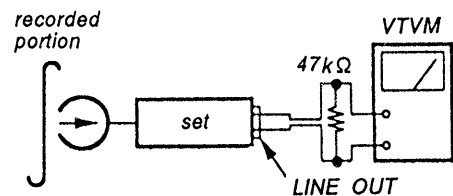

Playback the signal recorded in step 1.

Confirm that the 10 kHz playback output is  $0 \pm 0.5$  dB relative to the 315 Hz output. If necessary, adjust RV181 (L-ch) and RV281 (R-ch) for repeat the steps given above.

**Adjustment Location:** Audio system control (A) board

**Record Level Adjustment**

**Setting:**

REC LEVEL control: Standard Record (See page 12).  
test pin CNE707 : short

**Procedure:**

1. Mode: record

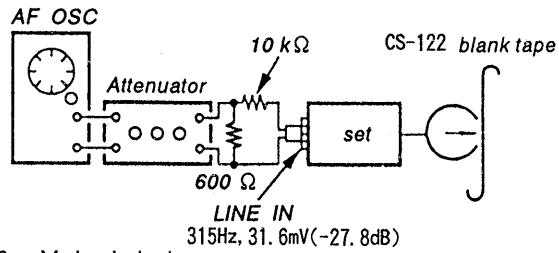

2. Mode: playback  
recorded portion

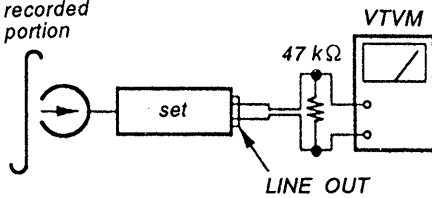

3. Playback the signal recorded in step 1.  
Confirm that the signal level is within the adjustment limits below. If necessary, adjust RV141 (L-ch) and RV241 (R-ch) repeat the step 1 - 2.

**Adjustment Limits:**  $-27.8 \pm 0.5\text{dB}$  (29 to 33.4mV)

**Adjustment Location:** MAIN (A) board

**Erase Current Adjustment : TC-K670/K677ES**

1. Mode : record

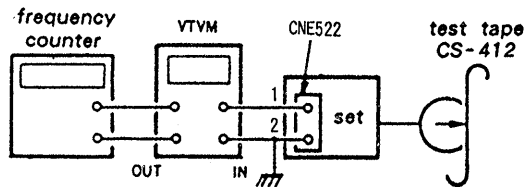

2. Adjust RV504 so that the reading on VTVM is 105mV (erase current=105mA).
3. And then confirm that the reading on the frequency counter is 160kHz.

**Adjustment Limits :**

Erase current : 105mA to 110mA  
Frequency :  $160 \pm 6\text{kHz}$

**Adjustment Location**

—MAIN (A) BOARD—

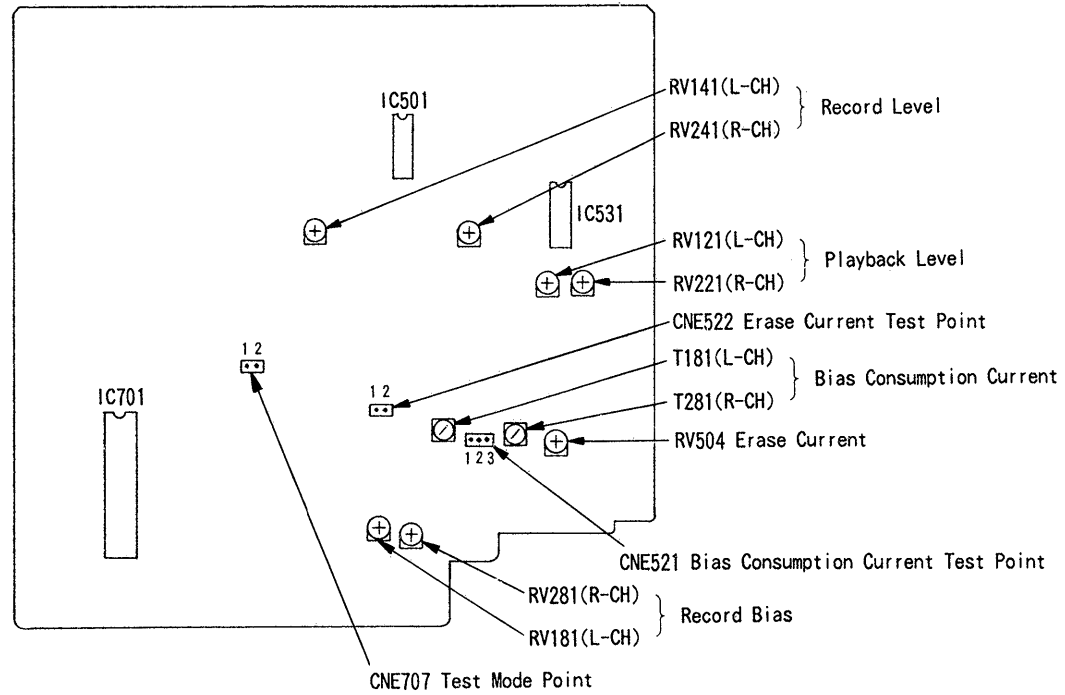

SECTION 5  
DIAGRAMS

5-1. PRINTED WIRING BOARDS • See page 21 for Semiconductor Lead Layouts and Circuit Boards Location.

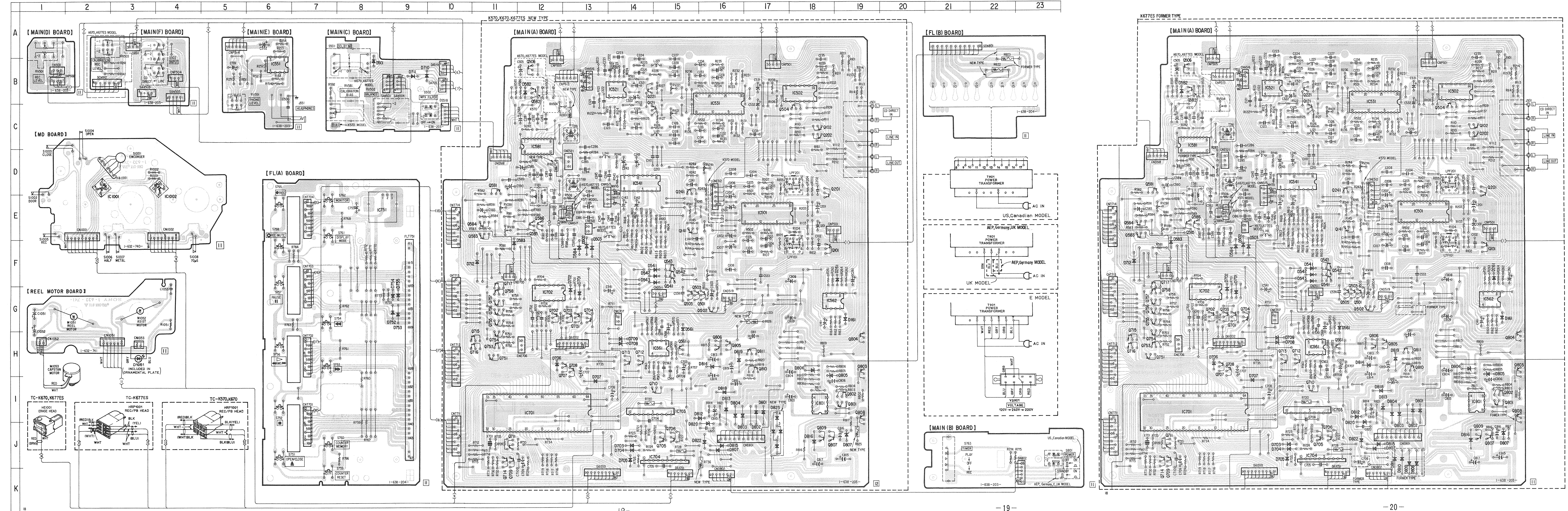

Note:

- — : parts extracted from the component side.
- K570 : TC-K570
- K670 : TC-K670
- K677ES : TC-K677ES

5-2. CIRCUIT BOARDS LOCATION

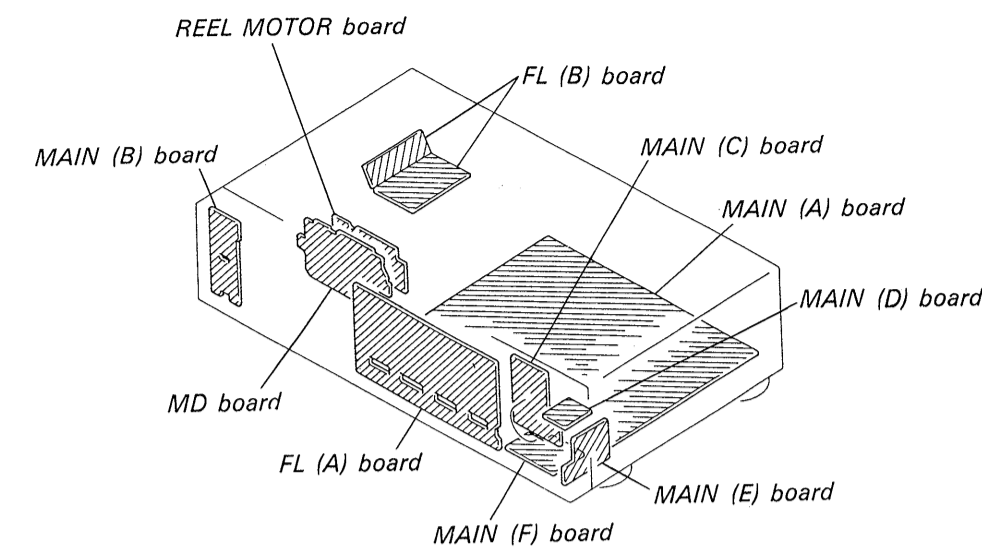

5-3. SEMICONDUCTOR LEAD LAYOUTS

• Semiconductor Location

Ref. No.	Location	Ref. No.	Location	Ref. No.	Location
D161	G-19	IC703	I-14	Q805	H-16
D261	F-19	IC704	J-15	Q806	H-16
D501	B-8	IC751	E-8	Q807	J-18
D502	F-13	IC801	I-18	Q808	I-19
D503	F-13	IC1001	D-2	Q809	H-19
D541	F-15	IC1002	D-4	Q810	H-17
D542	F-15			Q811	H-17
D543	F-15	Q101	F-18		
D561	G-15	Q102	C-18		
D582	B-12	Q121	C-14		
D583	F-11	Q141	E-15		
D584	F-13	Q201	D-18		
D701	G-13	Q202	C-18		
D702	G-13	Q221	B-14		
D703	J-14	Q241	D-15		
D704	J-14	Q501	G-16		
D705	J-14	Q502	G-16		
D706	H-12	Q503	G-15		
D707	I-13	Q504	C-18		
D708	H-14	Q505	G-15		
D709	H-14	Q506	B-12		
D710	B-9	Q541	F-15		
D711	B-9	Q542	F-15		
D712	F-11	Q543	F-15		
D752	G-9	Q561	H-15		
D753	G-9	Q581	D-11		
D754	G-9	Q582	B-12		
D755	G-9	Q583	E-11		
D801	I-17	Q584	E-11		
D802	I-17	Q585	E-12		
D803	I-16	Q586	E-12		
D804	I-16	Q701	G-13		
D805	H-18	Q702	G-12		
D806	H-18	Q703	G-13		
D807	J-16	Q704	G-13		
D812	I-15	Q705	J-15		
D813	I-16	Q706	J-15		
D814	H-16	Q707	H-13		
D815	J-16	Q708	H-13		
D816	J-18	Q709	J-11		
D817	J-19	Q710	I-15		
D818	I-16	Q711	J-11		
D819	H-16	Q712	H-14		
D820	J-16	Q713	H-14		
D822	J-16	Q714	J-11		
D823	J-17	Q715	H-11		
D1051	H-3	Q716	H-11		
		Q717	F-11		
IC501	E-17	Q751	H-11		
IC502	B-18	Q753	H-11		
IC521	B-14	Q754	H-11		
IC531	B-16	Q755	G-11		
IC541	D-14	Q756	G-11		
IC551	B-6	Q757	G-11		
IC561	H-15	Q758	G-11		
IC562	G-18	Q801	I-19		
IC581	C-12	Q802	I-19		
IC701	I-12	Q803	H-19		
IC702	G-12	Q804	H-19		

BA6219B

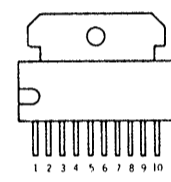

LB1641

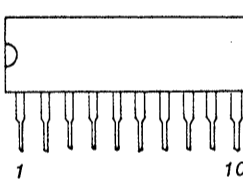

GP2S22B

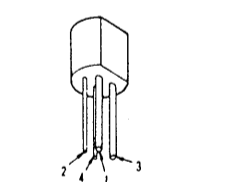

DTA114ES

DTA144ES

DTC114ES

DTC143TS

DTC144ES

2SA1317-STU

2SC2603-EF

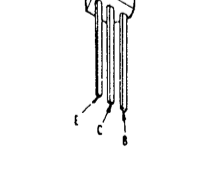

2SA1175-HFE

2SD1020-HFE

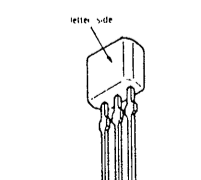

2SB1116A-L

2SC1815-Y

2SC945-P

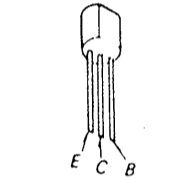

2SB1370-EF

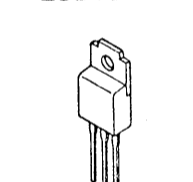

2SD1312-K

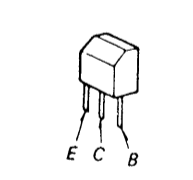

HZS6A1L

HZS8B1L

HZS7A1L

UZL-7H1

UZL-12M1

1SS120

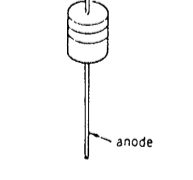

10E2N

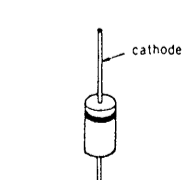

5-4. SCHEMATIC DIAGRAM—Audio Section— • See page 28 for note.

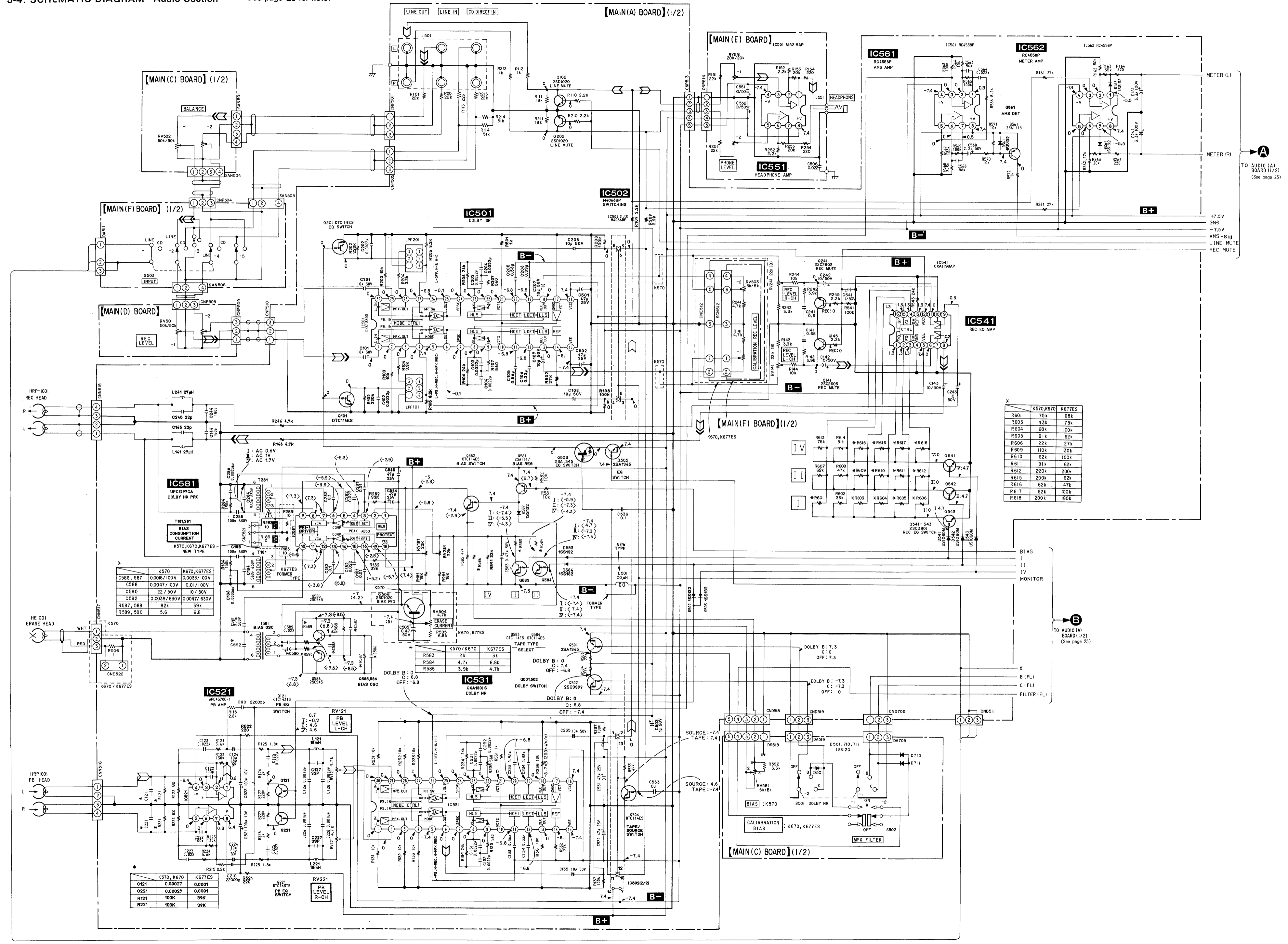

K570, K670	K677ES	C210	22000pF
C121	0.00027	0.0001	
C221	0.00027	0.0001	
R121	900K	99K	
R221	900K	99K	

K570, K670	K677ES
R601	75k 68k
R603	43k 75k
R604	68k 100k
R605	91k 27k
R606	22k 62k
R609	10k 130k
R610	62k 100k
R611	91k 62k
R612	220k 200k
R615	200k 62k
R616	62k 47k
R617	62k 100k
R618	200k 180k

5-5. SCHEMATIC DIAGRAM—System Control Section—

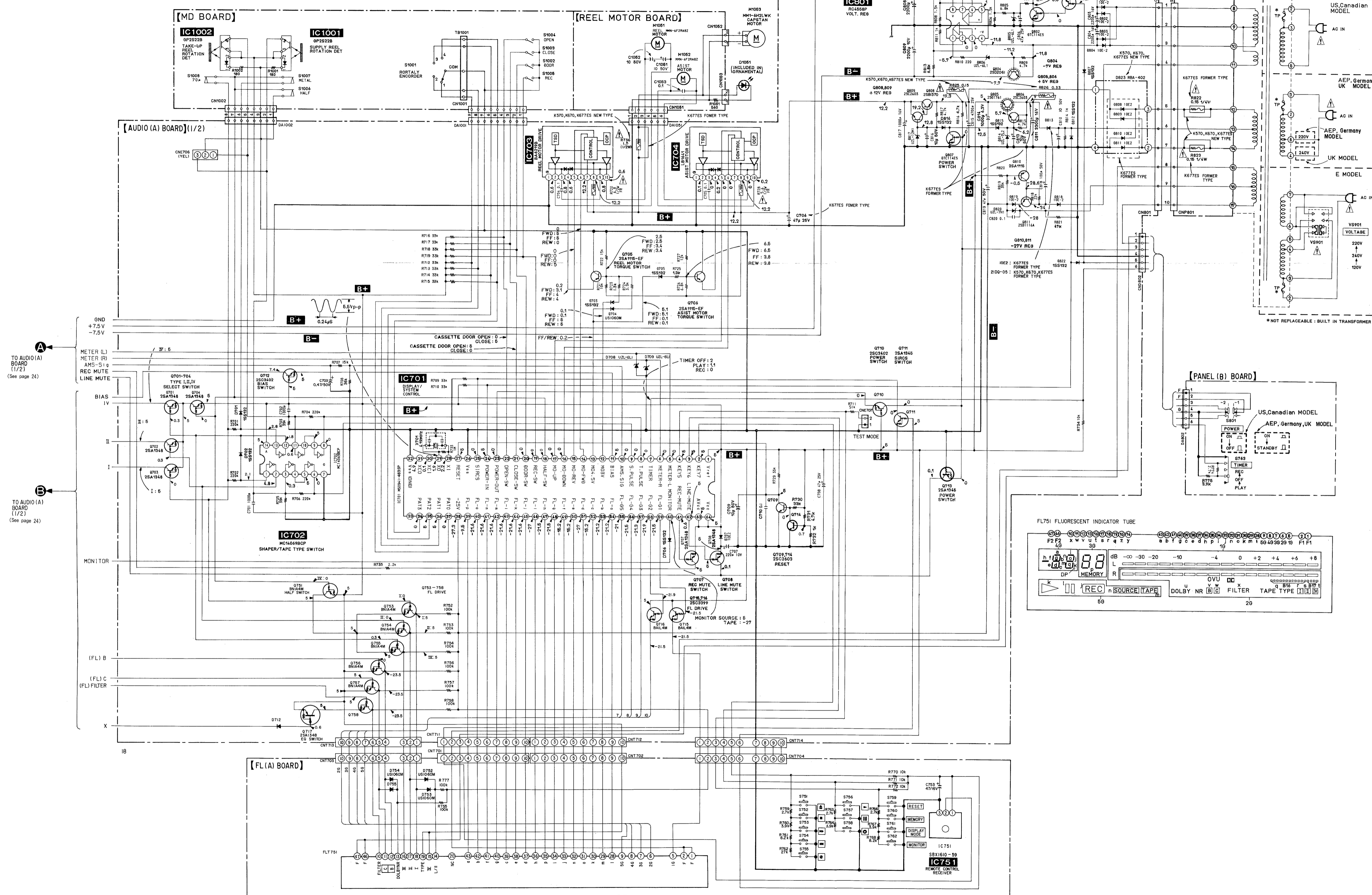

Note on Schematic Diagram:

- All capacitors are in  $\mu F$  unless otherwise noted. pF:  $\mu F$  50 kV or less are not indicated except for electrolytics and tantalums.
  - All resistors are in  $\Omega$  and  $\frac{1}{4} W$  or less unless otherwise specified.
  - $\Delta$ : internal component.
  - $\text{---}/\text{---}$ : fusible resistor.
- |   |   |
|---|---|
| <p>Note:</p> <p>The components identified by mark <math>\Delta</math> or dotted line with mark <math>\Delta</math> are critical for safety.</p> <p>Replace only with part number specified.</p> | <p>Note:</p> <p>Les composants identifiés par une marque <math>\Delta</math> sont critiques pour la sécurité.</p> <p>Ne les remplacer que par une pièce portant le numéro spécifié.</p> |
|---|---|

- **B+**: B + Line.
- **B-**: B - Line.
- $\text{---}/\text{---}$ : adjustment for repair.
- Voltages and waveforms for repair.
- no-signal conditions.
- no mark: STOP
- ( ): PLAY
- < >: REC
- | : NORMAL TAPE
- II : CrO<sub>2</sub> TAPE
- IV : METAL TAPE
- Voltages are taken with a VOM (impedance 10 M $\Omega$ ). Voltage variations may be noted due to normal production tolerances.
- Waveforms are taken with an oscilloscope. Voltage variations may be noted due to normal production tolerances.
- Signal path.
  - $\text{---}$ : PB
  - $\text{---}$ : REC
- K570 : TC-K570  
K670 : TC-K670  
K67ES : TC-K67ES

## SECTION 6 EXPLODED VIEWS

**NOTE:**

- -XX, -X mean standardized parts, so they may have some differences from the original one.
- The mechanical parts with no reference number in the exploded views are not supplied.
- Items marked "\*" are not stocked since they are seldom required for routine service. Some delay should be anticipated when ordering these items.

- Color Indication of Appearance Parts  
Example:  
KNOB, BALANCE(WHITE)...(RED)  
↑                    ↑  
Part's Color      Cabinet's Color
- Hardware (#mark) list is given in the last of this parts list.
- K570 : TC-K570  
K670 : TC-K670  
K677ES : TC-K677ES  
G : Germany

The components identified by mark or dotted line with mark are critical for safety. Replace only with part number specified.

Les composants identifiés par une marque sont critiques pour la sécurité. Ne les remplacer que par une pièce portant le numéro spécifié.

### 6-1. CHASSIS SECTION

▲B:FL(B)BOARD

■B-■F: See page 30

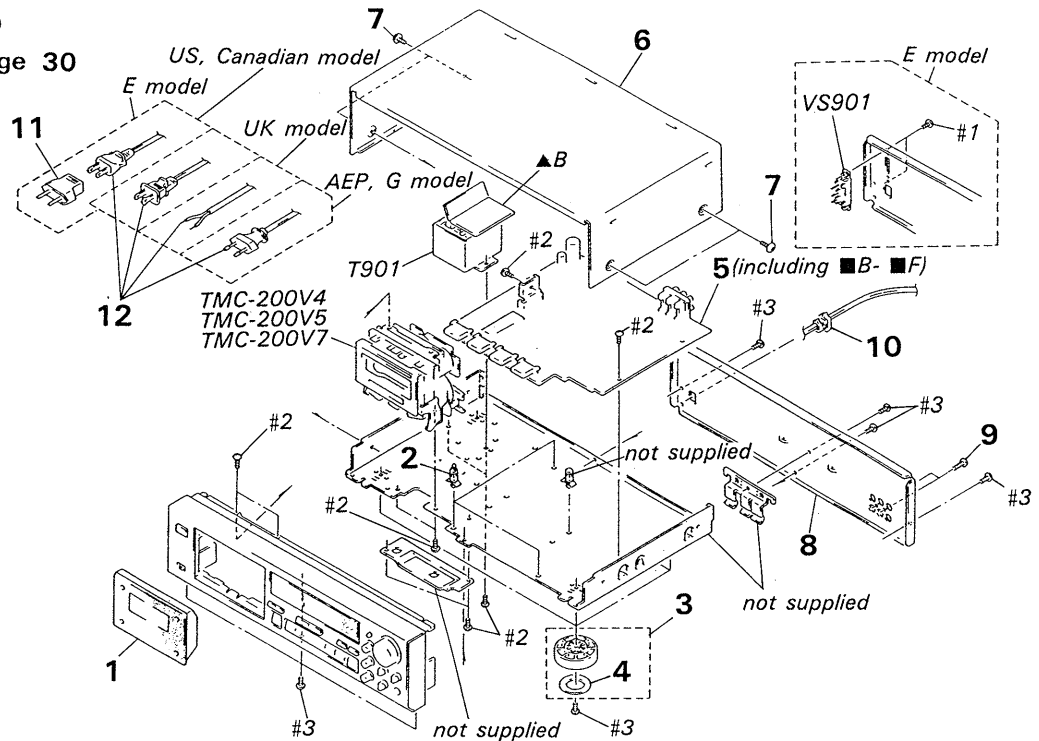

Ref. No.	Part No.	Description	Remark	Ref. No.	Part No.	Description	Remark
1	X-3363-010-1	LID (B) ASSY, CASSETTE (K677ES)		9	7-621-849-00	SCREW (BV/RING)	
1	X-3363-220-1	LID (A) ASSY, CASSETTE (K670)		10	* 3-703-571-11	BUSHING (S) (4516), CORD (K570:Canadian E/K670:US/K677ES:US, Canadian)	
1	X-3363-221-1	LID (A) ASSY, CASSETTE (K570)		10	* 3-703-244-00	BUSHING (2104), CORD (K570:AEP, G, UK/ K670:AEP, G/K677ES:UK)	
2	* 3-346-265-11	HOLDER, PC BOARD		11	▲ 1-569-007-11	ADAPTOR, CONVERSION 2P (K570:E3)	
3	X-3304-938-2	FOOT ASSY (K570:AEP, G, UK, E/ K670:AEP, G/K677ES)		12	▲ 1-551-188-XX	CORD, POWER (K570:E)	
3	X-4885-950-1	FOOT ASSY (K570:Canadian/K670:US)		12	▲ 1-551-506-XX	CORD, POWER (K570:Canadian/ K677ES:US, Canadian)	
4	4-923-836-11	CUSHION		12	▲ 1-555-465-00	CORD, POWER (K670:US)	
5	* A-2006-464-A	MAIN (A) BOARD, COMPLETE (K677ES)		12	▲ 1-555-795-00	CORD, POWER, EULO PLUG (K570:AEP, G/ K670:AEP, G)	
5	* A-2006-530-A	MAIN (A) BOARD, COMPLETE (INCLUDING MAIN (B)-MAIN (F) BOARD) (K570)		12	▲ 1-556-035-00	CORD, POWER (K570:UK/K677ES:UK)	
5	* A-2006-531-A	MAIN (A) BOARD, COMPLETE (INCLUDING MAIN (B)-MAIN (F) BOARD) (K670)		T901	▲ 1-450-100-11	TRANSFORMER, POWER (K570:Canadian/ K670:US/K677ES:US, Canadian)	
6	3-332-578-61	CASE		T901	▲ 1-450-101-11	TRANSFORMER, POWER (K570:E)	
7	3-704-366-01	SCREW (CASE) (M3X8)		T901	▲ 1-450-399-11	TRANSFORMER, POWER (K570:AEP, G, UK/ K670:AEP, G/K677ES:UK)	
8	* 3-367-791-01	PANEL, BACK (K670:US)		VS901	▲ 1-570-307-11	SWITCH, VOLTAGE CHANGE (K570:E)	
8	* 3-367-791-11	PANEL, BACK (K670:AEP, G)					
8	* 3-366-792-01	PANEL, BACK (K677ES:US, Canadian)					
8	* 3-367-792-01	PANEL, BACK (K570:AEP, G)					
8	* 3-366-792-11	PANEL, BACK (K677ES:UK)					
8	* 3-367-792-21	PANEL, BACK (K570:UK)					
8	* 3-367-792-31	PANEL, BACK (K570:Canadian)					
8	* 3-367-792-41	PANEL, BACK (K570:E)					



6-2. FRONT PANEL SECTION

- B: MAIN(B) BOARD
- C: MAIN(C) BOARD
- D: MAIN(D) BOARD
- E: MAIN(E) BOARD
- F: MAIN(F) BOARD

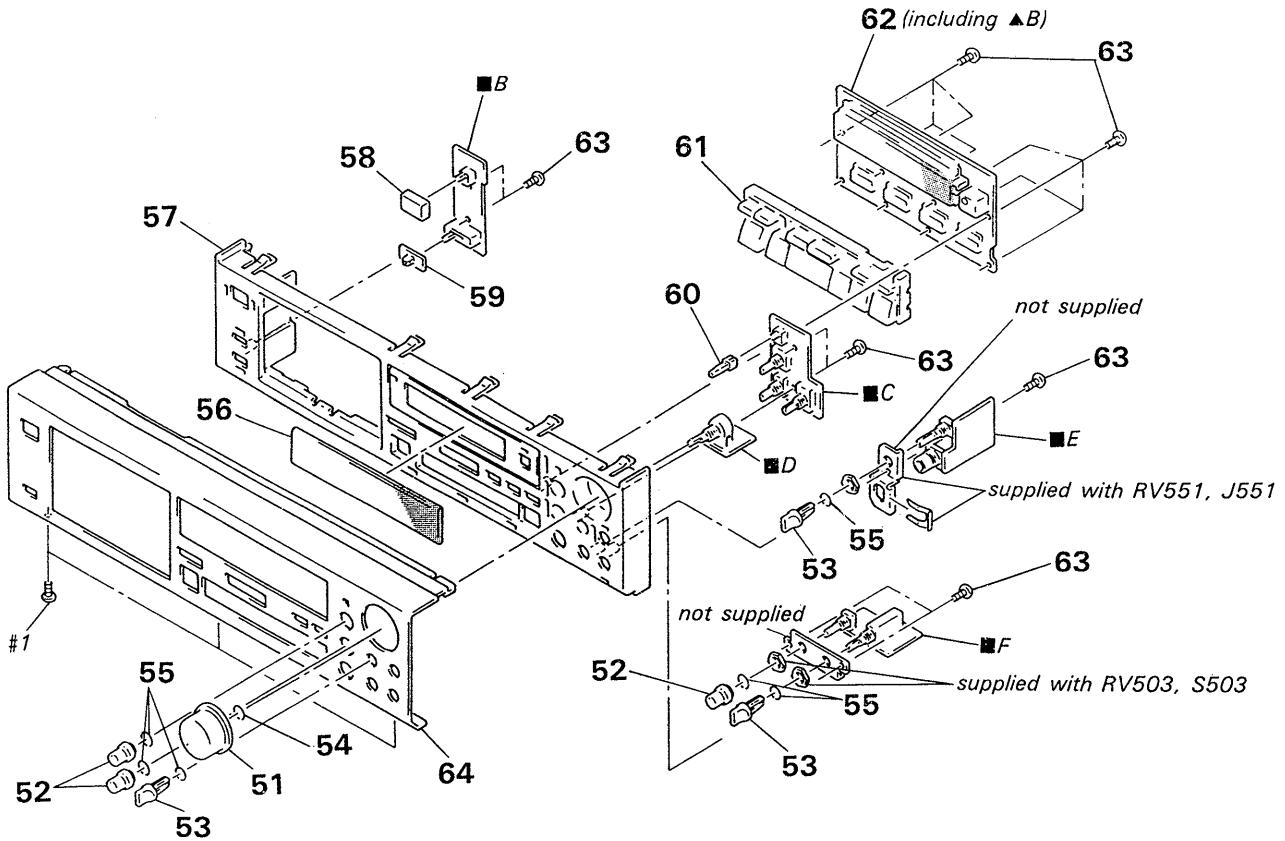

Ref.No.	Part No.	Description	Remark
51	3-367-438-12	KNOB (REC)	
52	3-367-431-01	KNOB (BAL)	
53	3-350-495-01	KNOB (VOL)	
54	3-350-426-01	SPRING	
55	3-356-957-01	SPRING	
56	3-367-433-12	WINDOW (METER) (K570/K670)	
56	3-367-430-02	WINDOW (METER) (K677ES)	
57	3-367-440-01	PANEL (BASE)	
58	4-922-921-01	BUTTON (POWER)	
59	4-931-421-11	KNOB (T & S)	
60	3-350-473-01	BUTTON	

Ref.No.	Part No.	Description	Remark
61	3-368-281-01	BUTTON (B)	
62	* 1-638-204-11	FL (A) BOARD (INCLUDING FL (B) BOARD)	
63	4-928-635-01	SCREW, +BV (2.6X8) TAPPING	
64	3-368-282-01	PANEL, FRONT (K677ES:US, Canadian)	
64	3-368-282-11	PANEL, FRONT (K677ES:UK)	
64	3-368-282-21	PANEL, FRONT (K670:US)	
64	3-368-282-31	PANEL, FRONT (K670:AEP, G)	
64	3-368-282-41	PANEL, FRONT (K570:Canadian)	
64	3-368-282-51	PANEL, FRONT (K570:AEP, G, UK, E)	

6-3. MECHANISM SECTION 1

- TC-K570 :TCM-200V7
- TC-K670 :TCM-200V5
- TC-K677ES :TCM-200V4

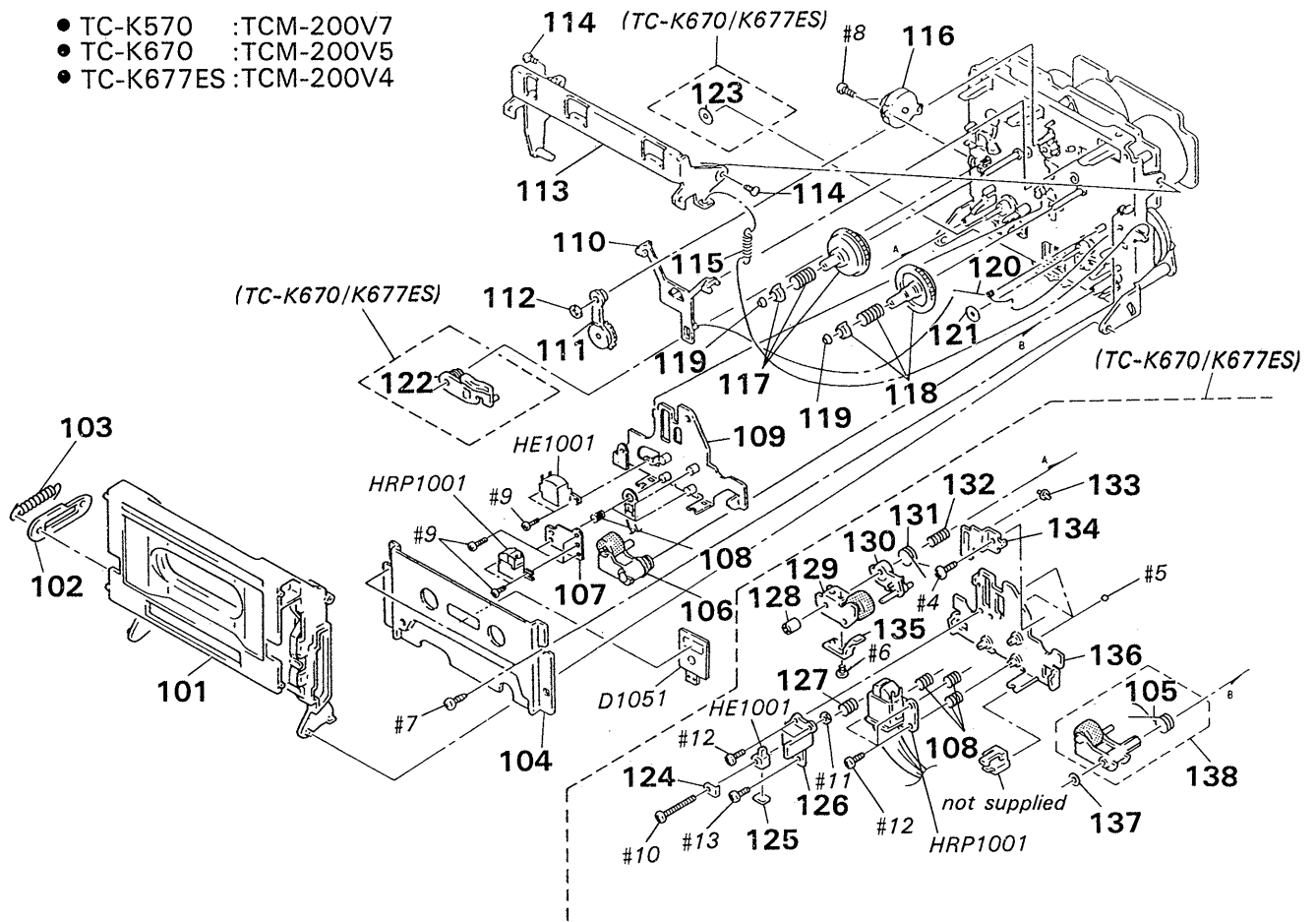

Ref.No.	Part No.	Description	Remark	Ref.No.	Part No.	Description	Remark
101	X-3362-814-1	HOLDER (CD) ASSY, CASSETTE		125	* 1-608-268-00	PC BOARD, ERASE HEAD (K670/K677ES)	
102	* 3-356-717-01	LEVER (JOINT)		125	3-564-121-00	SPRING, COMPRESSION (K670/K677ES)	
103	3-356-626-01	SPRING, TENSION		126	* 3-576-977-00	BRACKET, E. HEAD (K670/K677ES)	
104	X-3356-613-1	PLATE ASSY, ORNAMENTAL		128	3-356-652-01	NUT (PINCH LEVER S) (K670/K677ES)	
105	3-356-672-01	SPRING (PINCH LEVER T), TORSION (K670/K677ES)		129	X-3356-621-1	LEVER (PINCH LEVER S) ASSY (K670/K677ES)	
106	X-3356-649-1	LEVER (PINCH LEVER T) ASSY (K570)		130	3-356-660-01	LEVER (PS) (K670/K677ES)	
107	* 3-356-742-01	BRACKET (GUIDE R) (K570)		131	3-356-661-01	SPRING (PINCH LEVER S), TORSION (K670/K677ES)	
108	3-356-659-01	SPRING (RPH), COMPRESSION		132	3-356-657-01	SPRING (PS), COMPRESSION (K670/K677ES)	
109	X-3356-648-1	SLIDER (HEAD CHASSIS V2) ASSY (K570)		133	3-367-775-01	ROLLER (HEAD CHASSIS) (K670/K677ES)	
110	3-356-614-01	SLIDER (BRAKE)		134	3-356-656-01	SPRING (HEAD PC BOARD), LEAF (K670/K677ES)	
111	X-3356-641-1	LEVER (FR2) ASSY		135	3-564-138-00	GUIDE (S), TAPE (K670/K677ES)	
112	3-669-465-00	WASHER (1.5), STOPPER		136	* X-3362-861-1	SLIDER (HEAD CHASSIS V4) ASSY (K670/K677ES)	
113	* X-3356-608-1	LEVER (LIFTER) ASSY		137	3-669-596-00	WASHER (2.3), STOPPER (K670/K677ES)	
114	3-356-601-11	SCREW, STEP		138	X-3356-620-1	LEVER (PINCH LEVER T) ASSY (K670/K677ES)	
115	3-356-625-01	SPRING, TENSION		D1051	8-719-980-85	DIODE SLF-325C	
116	3-319-224-31	DAMPER, SMALL		HE1001	1-543-836-11	HEAD, MAGNETIC (ERASE) (K670/K677ES)	
117	X-3356-628-1	GEAR (S) ASSY (K570)		HE1001	1-543-535-11	HEAD, MAGNETIC (ERASE) (K570)	
117	X-3356-629-1	GEAR (S) ASSY (K670/K677ES)		HRP1001	1-543-733-11	HEAD, MAGNETIC (REC/PB) (K570)	
118	X-3356-627-1	GEAR (T) ASSY		HRP1001	1-543-834-11	HEAD, MAGNETIC (REC/PB) (K670)	
119	3-362-308-01	CAP (REEL)		HRP1001	1-543-835-11	HEAD, MAGNETIC (REC/PB) (K677ES)	
120	3-356-619-01	SPRING (B), TORSION					
121	3-332-763-01	RING, OIL RESERVOIR (K670/K677ES)					
121	3-356-713-01	WASHER (K570)					
122	X-3356-623-1	LEVER (BT) ASSY (K670/K677ES)					
123	3-356-713-01	WASHER (K670/K677ES)					
124	3-318-433-01	SPRING (K670/K677ES)					

6-4. MECHANISM SECTION 2

- TC-K570 :TCM-200V7
- TC-K670 :TCM-200V5
- TC-K677ES:TCM-200V4

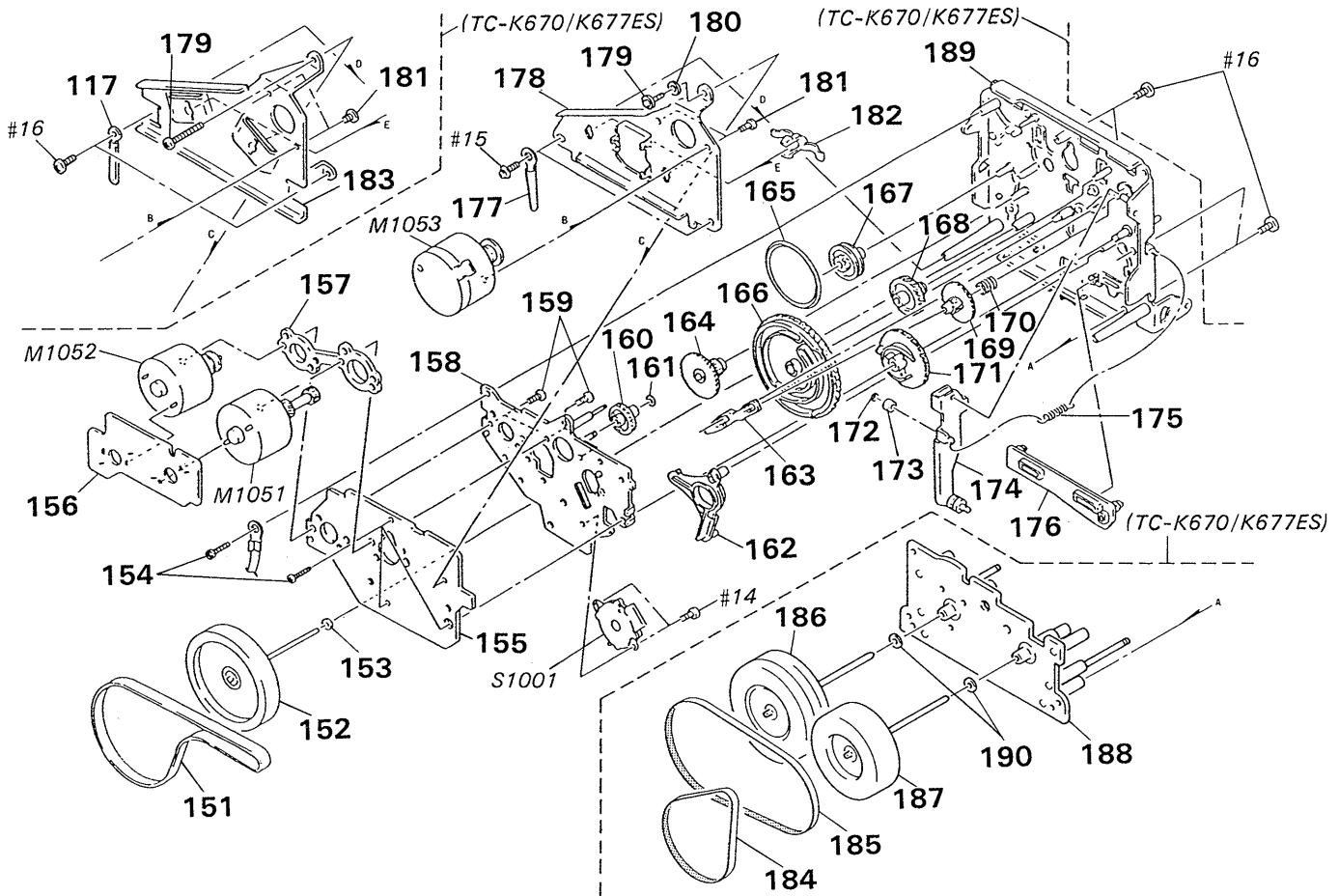

Ref. No.	Part No.	Description	Remark	Ref. No.	Part No.	Description	Remark
151	3-356-744-01	BELT (CAPSTAN V) (K570)		174	* X-3356-606-1	LEVER (LOADING) ASSY	
152	X-3356-642-1	FLYWHEEL (R FWD) ASSY (K570)		175	3-356-624-01	SPRING, TENSION	
153	3-356-705-01	WASHER (CAPSTAN) (K570)		176	3-356-653-01	SLIDER (PAUSE)	
154	3-355-801-01	SCREW (BTP 2X18)		177	* 3-701-822-00	HOLDER, WIRE	
155	* 1-632-740-11	MD BOARD		178	* 3-356-629-01	BRACKET (THRUST RETAINER R) (K570)	
156	* 1-632-741-11	REEL MOTOR BOARD		179	3-356-707-01	SCREW (+PTPWH 2X25)	
157	* 3-356-628-01	SPACER (MOTOR)		180	* 3-356-718-01	SPACER (THRUST RETAINER R) (K570)	
158	* X-3356-602-4	BRACKET (MOTOR R) ASSY (K570)		181	4-885-599-00	SCREW, FITTING, REINFORCEMENT	
158	* X-3356-616-4	BRACKET (MOTOR D) ASSY (K670/K677ES)		182	3-575-321-00	RETAINER, THRUST, CAPSTAN	
159	3-363-804-01	SCREW (+P 2.6X6.5)		183	* 3-367-773-01	BRACKET (THRUST RETAINER V4) (K670/K677ES)	
160	3-356-702-01	GEAR (COMMUNICATION B)		184	3-367-774-01	BELT (CAPSTAN V4) (K670/K677ES)	
161	3-669-465-00	WASHER (1.5), STOPPER		185	3-364-600-01	BELT (CAPSTAN) (K670/K677ES)	
162	3-356-613-01	LEVER (MODE)		186	X-3362-863-2	FLYWHEEL (VT) ASSY (K670/K677ES)	
163	3-356-617-01	LEVER (SELECTION)		187	X-3362-864-2	FLYWHEEL (VS) ASSY (K670/K677ES)	
164	3-356-606-01	GEAR (MODE)		188	* X-3362-865-1	BRACKET (CAPSTAN BASE) ASSY (K670/K677ES)	
165	3-356-603-01	BELT (MODE)		189	* X-3356-644-1	CHASSIS COMPLETE ASSY, MECH (K570)	
166	3-356-747-01	GEAR (MODE CAM C)		189	* X-3362-862-1	CHASSIS (V4) ASSY, MECHANICAL (K670/K677ES)	
167	3-356-607-01	PULLEY (MODE)		190	3-356-705-31	WASHER (CAPSTAN) (K670/K677ES)	
168	3-356-703-01	GEAR (COMMUNICATION C)		M1051	X-3356-638-1	MOTOR (REEL R) ASSY	
169	3-356-609-01	GEAR (LOADING)		M1052	X-3356-604-1	MOTOR (ASSIST) ASSY	
170	3-356-605-01	SPRING, COMPRESSION		M1053	X-3356-635-1	MOTOR (CAPSTAN R2) ASSY (K670/K677ES)	
171	3-356-616-01	GEAR (LOADING CAM)		M1053	X-3356-646-1	MOTOR (CAPSTAN V1) ASSY (K570)	
172	3-558-708-11	WASHER, STOPPER		S1001	1-466-238-11	ENCODER, ROTARY	
173	3-356-630-01	ROLLER (LOADING)					

## SECTION 7 ELECTRICAL PARTS LIST

**FL (A)**  
INCLUDING FL(B)

**NOTE:**

- Due to standardization, replacements in the parts list may be different from the parts specified in the diagrams or the components used on the set.
- Items marked "\*" are not stocked since they are seldom required for routine service. Some delay should be anticipated when ordering these items.
- -XX, -X mean standardized parts, so they may have some differences from the original one.
- RESISTORS  
All resistors are in ohms  
METAL : Metal-film resistor  
METAL OXIDE : Metal Oxide-film resistor  
F : nonflammable

- SEMICONDUCTORS  
In each case, u:μ, for example:  
uA... : μ A..., uPA... : μ P A...,  
uPB... : μ P B..., uPC... : μ P C...,  
uPD... : μ P D...
- CAPACITORS  
uF : μ F
- COILS  
uH : μ H
- K570 : TC-K570  
K670 : TC-K670  
K677ES : TC-K677ES  
G : Germany

When indicating parts by reference number, please include the board name.

The components identified by mark or dotted line with mark are critical for safety. Replace only with part number specified.

Les composants identifiés par une marque sont critiques pour la sécurité. Ne les remplacer que par une pièce portant le numéro spécifié.

Ref. No.	Part No.	Description	Remark
	* 1-638-204-11	FL (A) BOARD (INCLUDING FL (B) BOARD) *****	
	* 4-932-502-01	HOLDER, FL TUBE	
	9-911-844-XX	CUSHION	
		< CAPACITOR >	
C753	1-124-589-11	ELECT	47uF 20% 16V
		< CONNECTOR >	
CNT701	* 1-580-782-11	SOCKET, CONNECTOR	
CNT702	* 1-580-782-11	SOCKET, CONNECTOR	
CNT703	* 1-580-782-11	SOCKET, CONNECTOR	
CNT704	* 1-580-782-11	SOCKET, CONNECTOR	
		< DIODE >	
D752	8-719-912-20	DIODE 1SS120	
D753	8-719-912-20	DIODE 1SS120	
D754	8-719-912-20	DIODE 1SS120	
D755	8-719-912-20	DIODE 1SS120	
		< FLUORESCENT INDICATOR >	
FLT751	1-519-657-11	INDICATOR TUBE, FLUORESCENT	
		< IC >	
IC751	8-741-100-48	IC SBX1610-59	
		< RESISTOR >	
R755	1-249-441-11	CARBON	100K 5% 1/4W
R759	1-249-422-11	CARBON	2.7K 5% 1/4W
R760	1-249-424-11	CARBON	3.9K 5% 1/4W
R761	1-249-428-11	CARBON	8.2K 5% 1/4W
R762	1-249-434-11	CARBON	27K 5% 1/4W

Ref. No.	Part No.	Description	Remark
R763	1-249-422-11	CARBON	2.7K 5% 1/4W
R764	1-249-424-11	CARBON	3.9K 5% 1/4W
R766	1-249-422-11	CARBON	2.7K 5% 1/4W
R767	1-249-424-11	CARBON	3.9K 5% 1/4W
R768	1-249-428-11	CARBON	8.2K 5% 1/4W
		< SWITCH >	
R770	1-249-429-11	CARBON	10K 5% 1/4W
R771	1-249-429-11	CARBON	10K 5% 1/4W
R772	1-249-429-11	CARBON	10K 5% 1/4W
R777	1-249-441-11	CARBON	100K 5% 1/4W
R822	1-219-135-11	FUSIBLE	0.15 10% 1/4W (K677ES FORMER TYPE)
R823	1-219-135-11	FUSIBLE	0.15 10% 1/4W (K677ES FORMER TYPE)
S751	1-554-303-21	SWITCH, TACTILE (OPEN/CLOSE)	
S752	1-554-303-21	SWITCH, TACTILE (STOP)	
S753	1-554-303-21	SWITCH, TACTILE (FF)	
S754	1-554-303-21	SWITCH, TACTILE (REW)	
S755	1-554-303-21	SWITCH, TACTILE (REC)	
S756	1-554-303-21	SWITCH, TACTILE (PLAY/AMS)	
S757	1-554-303-21	SWITCH, TACTILE (PAUSE)	
S758	1-554-303-21	SWITCH, TACTILE (REC MUTE)	
S759	1-554-303-21	SWITCH, TACTILE (COUNTER RESET)	
S760	1-554-303-21	SWITCH, TACTILE (COUNTER MEMORY)	
S761	1-554-303-21	SWITCH, TACTILE (DISPLAY MODE)	
S762	1-554-303-21	SWITCH, TACTILE (MONITOR)	

**FL(A)**  
INCLUDING FL(B)

**MAIN(A)**

Ref. No.	Part No.	Description	Remark
	* 1-632-740-11	MD BOARD *****	
	3-356-631-01	HOLDER (SENSOR)  < CONNECTOR >	
CN1001	1-506-615-11	PIN, CONNECTOR 9P	
CN1002	1-564-501-11	PIN, CONNECTOR 8P  < IC >	
IC1001	8-749-920-97	IC PHOTO REFLECTOR GP2S22B	
IC1002	8-749-920-97	IC PHOTO REFLECTOR GP2S22B  < RESISTOR >	
R1001	1-249-408-11	CARBON 180 5% 1/4W	
R1002	1-249-408-11	CARBON 180 5% 1/4W  < SWITCH >	
S1002	1-570-953-11	SWITCH, PUSH (1 KEY) (DOOR)	
S1003	1-571-958-11	SWITCH, PUSH (1 KEY) (CLOSE)	
S1004	1-572-126-11	SWITCH, PUSH (1 KEY) (OPEN)	
S1005	1-572-125-11	SWITCH, LEAF (REC)	
S1006	1-572-202-11	SWITCH, LEAF (HALF)	
S1007	1-572-125-11	SWITCH, LEAF (METAL)	
S1008	1-572-125-11	SWITCH, LEAF (70uS)  < CONNECTOR >	
TB1001	* 1-569-066-11	PIN, CONNECTOR 5P	
*****			
	* A-2006-464-A	MAIN (A) BOARD, COMPLETE (INCLUDING MAIN (B)-MAIN(F) BOARD) (K677ES)	
	* A-2006-530-A	MAIN (A) BOARD, COMPLETE (INCLUDING MAIN (B)-MAIN(F) BOARD) (K570)	
	* A-2006-531-A	MAIN (A) BOARD, COMPLETE (INCLUDING MAIN (B)-MAIN(F) BOARD) (K670) *****	
	* 3-356-925-01	HEAT SINK  < CAPACITOR >	
C101	1-126-059-11	ELECT 10uF 20% 50V	
C102	1-106-351-00	MYLAR 2200PF 5% 200V	
C103	1-130-475-00	MYLAR 0.0022uF 5% 50V	
C104	1-130-475-00	MYLAR 0.0022uF 5% 50V	
C105	1-136-174-00	FILM 0.56uF 5% 50V	

Ref. No.	Part No.	Description	Remark
C106	1-136-171-00	FILM 0.33uF 5% 50V	
C107	1-126-059-11	ELECT 10uF 20% 50V	
C108	1-124-657-00	ELECT 10uF 20% 50V	
C110	1-161-494-00	CERAMIC 0.022uF 25V	
C121	1-110-335-11	MYLAR 100PF 5% 50V (K677ES)	
C121	1-110-340-11	MYLAR 270PF 5% 50V (K570/K670)	
C122	1-162-282-31	CERAMIC 100PF 10% 50V	
C123	1-130-487-00	MYLAR 0.022uF 5% 50V	
C124	1-124-657-00	ELECT 10uF 20% 50V	
C125	1-130-488-00	MYLAR 0.027uF 5% 50V	
C126	1-130-474-00	MYLAR 0.0018uF 5% 50V	
C127	1-102-518-11	CERAMIC 33PF 5% 50V	
C128	1-130-474-00	MYLAR 0.0018uF 5% 50V	
C131	1-130-475-00	MYLAR 0.0022uF 5% 50V	
C132	1-130-475-00	MYLAR 0.0022uF 5% 50V	
C133	1-136-174-00	FILM 0.56uF 5% 50V	
C134	1-136-171-00	FILM 0.33uF 5% 50V	
C135	1-124-657-00	ELECT 10uF 20% 50V	
C141	1-136-175-00	FILM 0.68uF 5% 50V	
C142	1-126-059-11	ELECT 10uF 20% 50V	
C143	1-126-059-11	ELECT 10uF 20% 50V	
C144	1-110-338-51	MYLAR 180PF 5% 50V	
C145	1-136-935-11	FILM 22PF 5% 630V	
C161	1-123-382-00	ELECT 3.3uF 20% 100V	
C181	1-136-153-00	FILM 0.01uF 5% 50V	
C182	1-136-157-00	FILM 0.022uF 5% 50V	
C183	1-136-165-00	FILM 0.1uF 5% 50V	
C184	1-136-803-11	FILM 560PF 5% 630V	
C185	1-136-433-11	FILM 100PF 5% 630V	
C186	1-130-468-00	MYLAR 560PF 5% 50V	
C201	1-126-059-11	ELECT 10uF 20% 50V	
C202	1-106-351-00	MYLAR 2200PF 5% 200V	
C203	1-130-475-00	MYLAR 0.0022uF 5% 50V	
C204	1-130-475-00	MYLAR 0.0022uF 5% 50V	
C205	1-136-174-00	FILM 0.56uF 5% 50V	
C206	1-136-171-00	FILM 0.33uF 5% 50V	
C207	1-126-059-11	ELECT 10uF 20% 50V	
C208	1-124-657-00	ELECT 10uF 20% 50V	
C210	1-161-494-00	CERAMIC 0.022uF 25V	
C221	1-110-335-11	MYLAR 100PF 5% 50V (K677ES)	
C221	1-110-340-11	MYLAR 270PF 5% 50V (K570/K670)	
C222	1-162-282-31	CERAMIC 100PF 10% 50V	
C223	1-130-487-00	MYLAR 0.022uF 5% 50V	
C224	1-124-657-00	ELECT 10uF 20% 50V	
C225	1-130-488-00	MYLAR 0.027uF 5% 50V	
C226	1-130-474-00	MYLAR 0.0018uF 5% 50V	

Ref. No.	Part No.	Description	Remark			Ref. No.	Part No.	Description	Remark		
C227	1-102-518-11	CERAMIC	33PF	5%	50V	C590	1-124-907-11	ELECT	10uF	20%	50V (K670/K677ES)
C228	1-130-474-00	MYLAR	0.0018uF	5%	50V	C590	1-126-233-11	ELECT	22uF	20%	50V (K570)
C231	1-130-475-00	MYLAR	0.0022uF	5%	50V	C591	1-107-045-00	MICA	3.9PF		500V
C232	1-130-475-00	MYLAR	0.0022uF	5%	50V	C592	1-136-558-11	FILM	0.0039uF	5%	630V (K570)
C233	1-136-174-00	FILM	0.56uF	5%	50V	C592	1-136-559-11	FILM	0.0047uF	5%	630V (K670/K677ES)
C234	1-136-171-00	FILM	0.33uF	5%	50V	C701	1-162-294-31	CERAMIC	0.001uF	10%	50V
C235	1-124-657-00	ELECT	10uF	20%	50V	C702	1-162-294-31	CERAMIC	0.001uF	10%	50V
C241	1-136-175-00	FILM	0.68uF	5%	50V	C703	1-124-902-00	ELECT	0.47uF	20%	50V
C242	1-126-059-11	ELECT	10uF	20%	50V	C704	1-164-159-11	CERAMIC	0.1uF		50V
C243	1-126-059-11	ELECT	10uF	20%	50V	C705	1-164-159-11	CERAMIC	0.1uF		50V
C244	1-110-338-51	MYLAR	180PF	5%	50V	C706	1-124-477-11	ELECT	47uF	20%	25V (K677ES FORMER TYPE)
C245	1-136-935-11	FILM	22PF	5%	630V	C707	1-126-176-11	ELECT	220uF	20%	10V
C261	1-123-382-00	ELECT	3.3uF	20%	100V	C708	1-124-477-11	ELECT	47uF	20%	25V
C281	1-136-153-00	FILM	0.01uF	5%	50V	C709	1-124-907-11	ELECT	10uF	20%	50V
C282	1-136-157-00	FILM	0.022uF	5%	50V	C710	1-164-159-11	CERAMIC	0.1uF		50V
C283	1-136-165-00	FILM	0.1uF	5%	50V	C803	1-124-556-11	ELECT	2200uF	20%	16V
C284	1-136-803-11	FILM	560PF	5%	630V	C804	1-124-556-11	ELECT	2200uF	20%	16V
C285	1-136-433-11	FILM	100PF	5%	630V	C806	1-124-477-11	ELECT	47uF	20%	25V
C286	1-130-468-00	MYLAR	560PF	5%	50V	C808	1-124-999-11	ELECT	2200uF	20%	10V
C501	1-126-022-11	ELECT	47uF	20%	25V	C809	1-124-999-11	ELECT	2200uF	20%	10V
C502	1-126-022-11	ELECT	47uF	20%	25V	C810	1-124-907-11	ELECT	10uF	20%	50V
C503	1-124-903-11	ELECT	1uF	20%	50V	C811	1-126-936-11	ELECT	3300uF	20%	16V
C505	1-124-902-00	ELECT	0.47uF	20%	50V (K670/K677ES)	C813	1-124-907-11	ELECT	10uF	20%	50V
C506	1-161-494-00	CERAMIC	0.022uF		25V	C814	1-126-916-11	ELECT	1000uF	20%	6.3V
C521	1-124-994-11	ELECT	100uF	20%	10V	C815	1-124-564-11	ELECT	4700uF	20%	25V
C522	1-124-994-11	ELECT	100uF	20%	10V	C816	1-124-907-11	ELECT	10uF	20%	50V
C531	1-126-022-11	ELECT	47uF	20%	25V	C817	1-124-360-00	ELECT	1000uF	20%	16V
C532	1-126-022-11	ELECT	47uF	20%	25V	C818	1-124-122-11	ELECT	100uF	20%	50V
C533	1-164-159-11	CERAMIC	0.1uF		50V	C819	1-124-910-11	ELECT	47uF	20%	50V
C536	1-164-159-11	CERAMIC	0.1uF		50V	C820	1-164-159-11	CERAMIC	0.1uF		50V
C541	1-124-903-11	ELECT	1uF	20%	50V	< CONNECTOR >					
C551	1-124-907-11	ELECT	10uF	20%	50V	CND511 *	1-564-337-00	PIN, CONNECTOR	3P		
C552	1-124-907-11	ELECT	10uF	20%	50V	CND518 *	1-564-339-00	PIN, CONNECTOR	5P		
C563	1-162-217-31	CERAMIC	56PF	5%	50V	CND519 *	1-564-337-61	PIN, CONNECTOR	3P		
C564	1-136-157-00	FILM	0.022uF	5%	50V	CND705 *	1-564-337-71	PIN, CONNECTOR	3P		
C566	1-162-217-31	CERAMIC	56PF	5%	50V	CND802 *	1-564-340-00	PIN, CONNECTOR	6P		
C568	1-124-925-11	ELECT	2.2uF	20%	100V	CNE512 *	1-564-508-11	PLUG, CONNECTOR	5P (K670/K677ES)		
C583	1-124-902-00	ELECT	0.47uF	20%	50V	CNE521 *	1-564-506-11	PLUG, CONNECTOR	3P		
C584	1-124-477-11	ELECT	47uF	20%	25V	CNE522 *	1-564-505-11	PLUG, CONNECTOR	2P (K670/K677ES)		
C585	1-124-477-11	ELECT	47uF	20%	25V	CNE706 *	1-564-506-11	PLUG, CONNECTOR	3P		
C586	1-136-253-11	FILM	0.0018uF	5%	100V (K570)	CNE707 *	1-564-505-11	PLUG, CONNECTOR	2P		
C586	1-136-593-11	FILM	0.0033uF	5%	100V (K670/K677ES)	CNE801 *	1-564-513-11	PLUG, CONNECTOR	10P		
C587	1-136-253-11	FILM	0.0018uF	5%	100V (K570)	CNN515 *	1-560-062-00	PIN, CONNECTOR	4P		
C587	1-136-593-11	FILM	0.0033uF	5%	100V (K670/K677ES)	CNN516 *	1-560-062-00	PIN, CONNECTOR	4P		
C588	1-130-955-00	FILM	0.01uF	5%	100V (K677ES)						
C588	1-136-233-11	FILM	0.0047uF	5%	100V (K570)						
C589	1-161-494-00	CERAMIC	0.022uF		25V						

## MAIN(A)

Ref. No.	Part No.	Description	Remark	Ref. No.	Part No.	Description	Remark
CNN517 *	1-560-060-00	PIN, CONNECTOR 2P (K570)		D807	8-719-912-20	DIODE 1SS120	
CNN517 *	1-560-061-00	PIN, CONNECTOR 3P (K670/K677ES)		D808	8-719-200-77	DIODE 10E2N (K677ES FORMER TYPE)	
CNP501 *	1-564-705-11	PIN, CONNECTOR (SMALL TYPE) 3P		D812	8-719-912-20	DIODE 1SS120	
CNP504 *	1-564-705-11	PIN, CONNECTOR (SMALL TYPE) 3P		D813	8-719-200-31	DIODE 21DQ05 (K570/K670/K677ES NEW TYPE)	
CNP505 *	1-564-705-11	PIN, CONNECTOR (SMALL TYPE) 3P		D813	8-719-200-77	DIODE 10E2N (K677ES FORMER TYPE)	
CNP508 *	1-564-705-11	PIN, CONNECTOR (SMALL TYPE) 3P		D814	8-719-933-43	DIODE HZS7A1L	
CNP509 *	1-564-719-11	PIN, CONNECTOR (SMALL TYPE) 3P		D815	8-719-912-20	DIODE 1SS120	
CNP510 *	1-564-705-11	PIN, CONNECTOR (SMALL TYPE) 3P		D816	8-719-912-20	DIODE 1SS120	
CNP513 *	1-564-707-11	PIN, CONNECTOR (SMALL TYPE) 5P		D817	8-719-001-70	DIODE UZL-12M1	
CNP514 *	1-564-707-11	PIN, CONNECTOR (SMALL TYPE) 5P		D818	8-719-200-77	DIODE 10E2N	
CNT711 *	1-580-784-11	PLUG, CONNECTOR		D819	8-719-200-77	DIODE 10E2N	
CNT712 *	1-580-784-11	PLUG, CONNECTOR		D820	8-719-000-93	DIODE UZL-7H1	
CNT713 *	1-580-784-11	PLUG, CONNECTOR		D822	8-719-912-20	DIODE 1SS120	
CNT714 *	1-580-784-11	PLUG, CONNECTOR		D823	8-719-312-09	DIODE RBA-402 (K570/K670/K677ES NEW TYPE)	
< DIODE >				< IC >			
D161	8-719-912-20	DIODE 1SS120		IC501	8-752-035-94	IC CXA1331S	
D261	8-719-912-20	DIODE 1SS120		IC502	8-759-000-49	IC MC14066BCP	
D501	8-719-912-20	DIODE 1SS120		IC521	8-759-111-44	IC uPC4570C-1	
D502	8-719-912-20	DIODE 1SS120		IC531	8-752-035-94	IC CXA1331S	
D503	8-719-912-20	DIODE 1SS120		IC541	8-752-038-02	IC CXA1198AP	
D541	8-719-912-20	DIODE 1SS120		IC551	8-759-634-51	IC M5218AP	
D542	8-719-912-20	DIODE 1SS120		IC561	8-759-945-58	IC RC4558P	
D543	8-719-912-20	DIODE 1SS120		IC562	8-759-945-58	IC RC4558P	
D561	8-719-912-20	DIODE 1SS120		IC581	8-759-106-56	IC uPC1297CA	
D582	8-719-912-20	DIODE 1SS120		IC701	8-759-635-71	IC M50941-483SP	
D583	8-719-912-20	DIODE 1SS120		IC702	8-759-240-69	IC TC4069UBP	
D584	8-719-912-20	DIODE 1SS120		IC703	8-759-973-95	IC BA6219B	
D701	8-719-912-20	DIODE 1SS120		IC704	8-759-822-09	IC LB1641	
D702	8-719-912-20	DIODE 1SS120		IC801	8-759-945-58	IC RC4558P	
D703	8-719-912-20	DIODE 1SS120		< JACK >			
D704	8-719-912-20	DIODE 1SS120		J501	1-565-320-11	JACK, PIN 6P (K570/K670)	
D705	8-719-912-20	DIODE 1SS120		J501	1-565-320-61	JACK, PIN 6P (LINE IN/LINE OUT/ CD DIRECT IN) (K677ES)	
D706	8-719-912-20	DIODE 1SS120		J551	1-507-796-71	JACK (HEADPHONES)	
D707	8-719-200-77	DIODE 10E2N		< COIL >			
D708	8-719-933-33	DIODE HZS6A1L		L121	1-410-778-11	INDUCTOR 18mH	
D709	8-719-933-33	DIODE HZS6A1L		L141	1-410-780-11	INDUCTOR 27mH	
D710	8-719-912-20	DIODE 1SS120		L221	1-410-778-11	INDUCTOR 18mH	
D711	8-719-912-20	DIODE 1SS120		L241	1-410-780-11	INDUCTOR 27mH	
D712	8-719-912-20	DIODE 1SS120		L501	1-408-080-00	INDUCTOR 100uH (K570/K670/K677ES NEW TYPE)	
D801	8-719-200-77	DIODE 10E2N		< FILTER >			
D802	8-719-200-77	DIODE 10E2N		LPF101	1-236-147-11	FILTER, LOW PASS	
D803	8-719-200-77	DIODE 10E2N		LPF201	1-236-147-11	FILTER, LOW PASS	
D804	8-719-200-77	DIODE 10E2N					
D805	8-719-933-33	DIODE HZS6A1L					
D806	8-719-933-33	DIODE HZS6A1L					

Ref. No.	Part No.	Description	Remark	Ref. No.	Part No.	Description	Remark
< TRANSISTOR >							
Q101	8-729-900-80	TRANSISTOR DTC114ES		Q756	8-729-900-61	TRANSISTOR DTA114ES	
Q102	8-729-142-25	TRANSISTOR 2SD1020-HFE		Q757	8-729-900-61	TRANSISTOR DTA114ES	
Q121	8-729-900-74	TRANSISTOR DTC143TS		Q758	8-729-900-61	TRANSISTOR DTA114ES	
Q141	8-729-620-05	TRANSISTOR 2SC2603-EF		Q801	8-729-900-61	TRANSISTOR DTA114ES	
Q201	8-729-900-80	TRANSISTOR DTC114ES		Q802	8-729-900-80	TRANSISTOR DTC114ES	
Q202	8-729-142-25	TRANSISTOR 2SD1020-HFE		Q803	8-729-924-90	TRANSISTOR 2SB1370-EF	
Q221	8-729-900-74	TRANSISTOR DTC143TS		Q804	8-729-111-55	TRANSISTOR 2SD1312-K	
Q241	8-729-620-05	TRANSISTOR 2SC2603-EF		Q805	8-729-111-55	TRANSISTOR 2SD1312-K	
Q501	8-729-900-65	TRANSISTOR DTA144ES		Q806	8-729-620-05	TRANSISTOR 2SC2603-EF	
Q502	8-729-900-89	TRANSISTOR DTC144ES		Q807	8-729-900-80	TRANSISTOR DTC114ES	
Q503	8-729-900-65	TRANSISTOR DTA144ES		Q808	8-729-924-90	TRANSISTOR 2SB1370-EF	
Q504	8-729-900-80	TRANSISTOR DTC114ES		Q809	8-729-620-05	TRANSISTOR 2SC2603-EF	
Q505	8-729-900-65	TRANSISTOR DTA144ES		Q810	8-729-119-76	TRANSISTOR 2SA1175-HFE	
Q506	8-729-142-25	TRANSISTOR 2SD1020-HFE (K670/K677ES)		Q811	8-729-140-04	TRANSISTOR 2SB1116A-L	
Q541	8-729-900-74	TRANSISTOR DTC143TS		< RESISTOR >			
Q542	8-729-900-74	TRANSISTOR DTC143TS		R101	1-259-460-11	CARBON 22K 5%	1/6W
Q543	8-729-900-74	TRANSISTOR DTC143TS		R102	1-259-484-11	CARBON 220K 5%	1/6W
Q561	8-729-119-76	TRANSISTOR 2SA1175-HFE		R103	1-249-429-11	CARBON 10K 5%	1/4W
Q581	8-729-821-04	TRANSISTOR 2SA1317-STU		R104	1-259-440-11	CARBON 3.3K 5%	1/6W
Q582	8-729-900-80	TRANSISTOR DTC114ES		R105	1-259-450-11	CARBON 8.2K 5%	1/6W
Q583	8-729-900-80	TRANSISTOR DTC114ES		R106	1-259-461-11	CARBON 24K 5%	1/6W
Q584	8-729-900-80	TRANSISTOR DTC114ES		R107	1-259-422-11	CARBON 560 5%	1/6W
Q585	8-729-194-57	TRANSISTOR 2SC945-P		R108	1-259-476-11	CARBON 100K 5%	1/6W
Q586	8-729-194-57	TRANSISTOR 2SC945-P		R109	1-259-436-11	CARBON 2.2K 5%	1/6W
Q701	8-729-900-61	TRANSISTOR DTA114ES		R110	1-249-421-11	CARBON 2.2K 5%	1/4W
Q702	8-729-900-61	TRANSISTOR DTA114ES		R111	1-259-458-11	CARBON 18K 5%	1/6W
Q703	8-729-900-61	TRANSISTOR DTA114ES		R112	1-259-428-11	CARBON 1K 5%	1/6W
Q704	8-729-900-61	TRANSISTOR DTA114ES		R113	1-259-460-11	CARBON 22K 5%	1/6W
Q705	8-729-119-76	TRANSISTOR 2SA1175-HFE		R114	1-259-469-11	CARBON 51K 5%	1/6W
Q706	8-729-119-76	TRANSISTOR 2SA1175-HFE		R115	1-249-421-11	CARBON 2.2K 5%	1/4W
Q707	8-729-900-61	TRANSISTOR DTA114ES		R121	1-259-466-11	CARBON 39K 5%	1/6W (K677ES)
Q708	8-729-900-61	TRANSISTOR DTA114ES		R121	1-259-476-11	CARBON 100K 5%	1/6W (K570/K670)
Q709	8-729-620-05	TRANSISTOR 2SC2603-EF		R122	1-259-402-11	CARBON 82 5%	1/6W
Q710	8-729-900-80	TRANSISTOR DTC114ES		R123	1-259-479-11	CARBON 130K 5%	1/6W
Q711	8-729-900-65	TRANSISTOR DTA144ES		R124	1-259-446-11	CARBON 5.6K 5%	1/6W
Q712	8-729-900-80	TRANSISTOR DTC114ES		R125	1-259-434-11	CARBON 1.8K 5%	1/6W
Q713	8-729-900-65	TRANSISTOR DTA144ES		R126	1-259-435-11	CARBON 2K 5%	1/6W
Q714	8-729-620-05	TRANSISTOR 2SC2603-EF		R127	1-259-484-11	CARBON 220K 5%	1/6W
Q715	8-729-900-89	TRANSISTOR DTC144ES		R131	1-249-429-11	CARBON 10K 5%	1/4W
Q716	8-729-900-89	TRANSISTOR DTC144ES		R132	1-249-429-11	CARBON 10K 5%	1/4W
Q717	8-729-900-61	TRANSISTOR DTA114ES		R133	1-249-429-11	CARBON 10K 5%	1/4W
Q751	8-729-900-61	TRANSISTOR DTA114ES		R134	1-259-461-11	CARBON 24K 5%	1/6W
Q753	8-729-900-61	TRANSISTOR DTA114ES		R135	1-259-422-11	CARBON 560 5%	1/6W
Q754	8-729-900-61	TRANSISTOR DTA114ES		R136	1-259-452-11	CARBON 10K 5%	1/6W
Q755	8-729-900-61	TRANSISTOR DTA114ES		R137	1-259-476-11	CARBON 100K 5%	1/6W
				R141	1-259-444-11	CARBON 4.7K 5%	1/6W (K670/K677ES)
				R142	1-259-442-11	CARBON 3.9K 5%	1/6W



MAIN(A)

Ref. No.	Part No.	Description	Remark		
R143	1-259-440-11	CARBON	3. 3K	5%	1/6W
R144	1-259-452-11	CARBON	10K	5%	1/6W
R145	1-249-421-11	CARBON	2. 2K	5%	1/4W
R146	1-259-444-11	CARBON	4. 7K	5%	1/6W
R151	1-249-433-11	CARBON	22K	5%	1/4W
R152	1-249-421-11	CARBON	2. 2K	5%	1/4W
R153	1-247-862-11	CARBON	20K	5%	1/4W
R154	1-249-409-11	CARBON	220	5%	1/4W
R161	1-249-434-11	CARBON	27K	5%	1/4W
R162	1-247-866-11	CARBON	30K	5%	1/4W
R163	1-249-436-11	CARBON	39K	5%	1/4W
R164	1-249-409-11	CARBON	220	5%	1/4W
R181	1-249-432-11	CARBON	18K	5%	1/4W
R182	1-249-435-11	CARBON	33K	5%	1/4W
R183	△ 1-219-153-11	FUSIBLE (K570/K670/K677ES NEW TYPE)	10	5%	1/4W F
R183	1-249-393-11	CARBON (K677ES FORMER TYPE)	10	5%	1/4W
R184	1-247-883-00	CARBON	150K	5%	1/4W
R201	1-259-460-11	CARBON	22K	5%	1/6W
R202	1-259-484-11	CARBON	220K	5%	1/6W
R203	1-249-429-11	CARBON	10K	5%	1/4W
R204	1-259-440-11	CARBON	3. 3K	5%	1/6W
R205	1-259-450-11	CARBON	8. 2K	5%	1/6W
R206	1-259-461-11	CARBON	24K	5%	1/6W
R207	1-259-422-11	CARBON	560	5%	1/6W
R208	1-259-476-11	CARBON	100K	5%	1/6W
R209	1-259-436-11	CARBON	2. 2K	5%	1/6W
R210	1-249-421-11	CARBON	2. 2K	5%	1/4W
R211	1-259-458-11	CARBON	18K	5%	1/6W
R212	1-259-428-11	CARBON	1K	5%	1/6W
R213	1-259-460-11	CARBON	22K	5%	1/6W
R214	1-259-469-11	CARBON	51K	5%	1/6W
R215	1-249-421-11	CARBON	2. 2K	5%	1/4W
R221	1-259-466-11	CARBON	39K	5%	1/6W (K677ES)
R221	1-259-476-11	CARBON	100K	5%	1/6W (K570/K670)
R222	1-259-402-11	CARBON	82	5%	1/6W
R223	1-259-479-11	CARBON	130K	5%	1/6W
R224	1-259-446-11	CARBON	5. 6K	5%	1/6W
R225	1-259-434-11	CARBON	1. 8K	5%	1/6W
R226	1-259-435-11	CARBON	2K	5%	1/6W
R227	1-259-484-11	CARBON	220K	5%	1/6W
R231	1-249-429-11	CARBON	10K	5%	1/4W
R232	1-249-429-11	CARBON	10K	5%	1/4W
R233	1-249-429-11	CARBON	10K	5%	1/4W
R234	1-259-461-11	CARBON	24K	5%	1/6W

Ref. No.	Part No.	Description	Remark		
R235	1-259-422-11	CARBON	560	5%	1/6W
R236	1-259-452-11	CARBON	10K	5%	1/6W
R237	1-259-476-11	CARBON	100K	5%	1/6W
R241	1-259-444-11	CARBON	4. 7K	5%	1/6W (K670/K677ES)
R242	1-259-442-11	CARBON	3. 9K	5%	1/6W
R243	1-259-440-11	CARBON	3. 3K	5%	1/6W
R244	1-259-452-11	CARBON	10K	5%	1/6W
R245	1-249-421-11	CARBON	2. 2K	5%	1/4W
R246	1-259-444-11	CARBON	4. 7K	5%	1/6W
R251	1-249-433-11	CARBON	22K	5%	1/4W
R252	1-249-421-11	CARBON	2. 2K	5%	1/4W
R253	1-247-862-11	CARBON	20K	5%	1/4W
R254	1-249-409-11	CARBON	220	5%	1/4W
R261	1-249-434-11	CARBON	27K	5%	1/4W
R262	1-247-866-11	CARBON	30K	5%	1/4W
R263	1-249-436-11	CARBON	39K	5%	1/4W
R264	1-249-409-11	CARBON	220	5%	1/4W
R281	1-249-432-11	CARBON	18K	5%	1/4W
R282	1-249-435-11	CARBON	33K	5%	1/4W
R283	△ 1-219-153-11	FUSIBLE (K570/K670/K677ES NEW TYPE)	10	5%	1/4W F
R283	1-249-393-11	CARBON (K677ES FORMER TYPE)	10	5%	1/4W
R284	1-247-883-00	CARBON	150K	5%	1/4W
R501	1-259-428-11	CARBON	1K	5%	1/6W
R502	1-215-455-00	METAL	27K	1%	1/6W
R503	1-249-421-11	CARBON	2. 2K	5%	1/4W
R504	1-249-421-11	CARBON	2. 2K	5%	1/4W
R505	1-249-427-11	CARBON	6. 8K	5%	1/4W (K670/K677ES)
R506	1-249-381-11	CARBON	1	5%	1/4W (K670/K677ES)
R521	1-247-704-11	CARBON	220	5%	1/4W
R522	1-247-704-11	CARBON	220	5%	1/4W
R531	1-259-428-11	CARBON	1K	5%	1/6W
R532	1-215-455-00	METAL	27K	1%	1/6W
R533	1-249-437-11	CARBON	47K	5%	1/4W
R541	1-249-441-11	CARBON	100K	5%	1/4W
R543	1-215-454-00	METAL	24K	1%	1/6W
R563	1-249-441-11	CARBON	100K	5%	1/4W
R564	1-249-429-11	CARBON	10K	5%	1/4W
R565	1-249-441-11	CARBON	100K	5%	1/4W
R566	1-249-428-11	CARBON	8. 2K	5%	1/4W
R567	1-249-441-11	CARBON	100K	5%	1/4W
R568	1-249-423-11	CARBON	3. 3K	5%	1/4W
R569	1-249-441-11	CARBON	100K	5%	1/4W
R570	1-249-429-11	CARBON	10K	5%	1/4W
R571	1-249-429-11	CARBON	10K	5%	1/4W
R572	1-249-417-11	CARBON	1K	5%	1/4W
R581	1-249-429-11	CARBON	10K	5%	1/4W
R582	1-249-429-11	CARBON	10K	5%	1/4W

**Note:**  
The components identified by mark **△** or dotted line with mark **△** are critical for safety. Replace only with part number specified.

**Note:**  
Les composants identifiés par une marque **△** sont critiques pour la sécurité. Ne les remplacer que par une pièce portant le numéro spécifié.

MAIN(A)

Ref. No.	Part No.	Description	Remark	Ref. No.	Part No.	Description	Remark
R583	1-247-838-11	CARBON	2K (K570/K670)	R613	1-247-876-11	CARBON	75K 5% 1/4W
R583	1-247-842-11	CARBON	3K 5% 1/4W (K677ES)	R614	1-247-872-11	CARBON	51K 5% 1/4W
R584	1-249-425-11	CARBON	4.7K 5% 1/4W (K570/K670)	R615	1-247-874-11	CARBON	62K 5% 1/4W (K677ES)
R584	1-249-427-11	CARBON	6.8K 5% 1/4W (K677ES)	R615	1-247-886-11	CARBON	200K 5% 1/4W (K570/K670)
R585	1-249-437-11	CARBON	47K 5% 1/4W	R616	1-247-874-11	CARBON	62K 5% 1/4W (K570/K670)
R586	1-249-424-11	CARBON	3.9K 5% 1/4W (K570/K670)	R616	1-249-437-11	CARBON	47K 5% 1/4W (K677ES)
R586	1-249-425-11	CARBON	4.7K 5% 1/4W (K677ES)	R617	1-247-874-11	CARBON	62K 5% 1/4W (K570/K670)
R587	1-249-436-11	CARBON	39K 5% 1/4W (K670/K677ES)	R617	1-249-441-11	CARBON	100K 5% 1/4W (K677ES)
R587	1-249-440-11	CARBON	82K 5% 1/4W (K570)	R618	1-247-885-00	CARBON	180K 5% 1/4W (K677ES)
R588	1-249-436-11	CARBON	39K 5% 1/4W (K670/K677ES)	R618	1-247-886-11	CARBON	200K 5% 1/4W (K570/K670)
R588	1-249-440-11	CARBON	82K 5% 1/4W (K570)	R701	1-247-887-00	CARBON	220K 5% 1/4W
R589	1-249-390-11	CARBON	5.6 5% 1/4W (K570)	R702	1-247-887-00	CARBON	220K 5% 1/4W
R589	1-249-391-11	CARBON	6.8 5% 1/4W (K670/K677ES)	R703	1-249-436-11	CARBON	39K 5% 1/4W
R590	1-249-390-11	CARBON	5.6 5% 1/4W (K570)	R704	1-247-887-00	CARBON	220K 5% 1/4W
R590	1-249-391-11	CARBON	6.8 5% 1/4W (K670/K677ES)	R705	1-249-436-11	CARBON	39K 5% 1/4W
R591	1-249-435-11	CARBON	33K 5% 1/4W	R706	1-247-887-00	CARBON	220K 5% 1/4W
R592	1-249-423-11	CARBON	3.3K 5% 1/4W	R707	1-249-431-11	CARBON	15K 5% 1/4W
R601	1-247-876-11	CARBON	75K 5% 1/4W (K570/K670)	R708	1-247-868-11	CARBON	36K 5% 1/4W
R601	1-249-439-11	CARBON	68K 5% 1/4W (K677ES)	R709	1-249-435-11	CARBON	33K 5% 1/4W
R602	1-249-435-11	CARBON	33K 5% 1/4W	R710	1-249-435-11	CARBON	33K 5% 1/4W
R603	1-247-870-11	CARBON	43K 5% 1/4W (K570/K670)	R711	1-247-872-11	CARBON	51K 5% 1/4W
R603	1-247-876-11	CARBON	75K 5% 1/4W (K677ES)	R712	1-249-435-11	CARBON	33K 5% 1/4W
R604	1-247-439-11	CARBON	68K 5% 1/4W (K570/K670)	R713	1-249-435-11	CARBON	33K 5% 1/4W
R604	1-249-441-11	CARBON	100K 5% 1/4W (K677ES)	R714	1-249-435-11	CARBON	33K 5% 1/4W
R605	1-247-874-11	CARBON	62K 5% 1/4W (K677ES)	R715	1-249-435-11	CARBON	33K 5% 1/4W
R605	1-247-878-00	CARBON	91K 5% 1/4W (K570/K670)	R716	1-249-435-11	CARBON	33K 5% 1/4W
R606	1-249-433-11	CARBON	22K 5% 1/4W (K570/K670)	R717	1-249-435-11	CARBON	33K 5% 1/4W
R606	1-249-434-11	CARBON	27K 5% 1/4W (K677ES)	R718	1-249-435-11	CARBON	33K 5% 1/4W
R607	1-247-874-11	CARBON	62K 5% 1/4W	R719	1-249-435-11	CARBON	33K 5% 1/4W
R608	1-249-437-11	CARBON	47K 5% 1/4W	R720	△ 1-212-954-11	FUSIBLE	6.8 5% 1/2W F
R609	1-247-880-11	CARBON	110K 5% 1/4W (K570/K670)	R721	1-249-429-11	CARBON	10K 5% 1/4W
R609	1-247-882-00	CARBON	130K 5% 1/4W (K677ES)	R722	1-249-431-11	CARBON	15K 5% 1/4W
R610	1-247-874-11	CARBON	62K 5% 1/4W (K570/K670)	R723	1-247-834-11	CARBON	1.3K 5% 1/4W
R610	1-249-441-11	CARBON	100K 5% 1/4W (K677ES)	R724	1-249-424-11	CARBON	3.9K 5% 1/4W
R611	1-247-874-11	CARBON	62K 5% 1/4W (K677ES)	R725	1-247-834-11	CARBON	1.3K 5% 1/4W
R611	1-247-878-11	CARBON	91K 5% 1/4W (K570/K670)	R726	1-249-427-11	CARBON	6.8K 5% 1/4W
R612	1-247-886-11	CARBON	200K 5% 1/4W (K677ES)	R727	1-249-430-11	CARBON	12K 5% 1/4W
R612	1-247-887-11	CARBON	220K 5% 1/4W (K570/K670)	R728	△ 1-212-952-00	FUSIBLE	5.6 5% 1/2W F
				R729	1-249-435-11	CARBON	33K 5% 1/4W
				R730	1-249-435-11	CARBON	33K 5% 1/4W
				R731	1-249-425-11	CARBON	4.7K 5% 1/4W
				R732	1-249-417-11	CARBON	1K 5% 1/4W
				R733	1-247-903-00	CARBON	1M 5% 1/4W
				R734	1-249-429-11	CARBON	10K 5% 1/4W
				R735	1-249-421-11	CARBON	2.2K 5% 1/4W

**Note:**  
The components identified by mark  $\Delta$  or dotted line with mark  $\Delta$  are critical for safety. Replace only with part number specified.

**Note:**  
Les composants identifiés par une marque  $\Delta$  sont critiques pour la sécurité. Ne les remplacer que par une pièce portant le numéro spécifié.

MAIN(A)

REAL MOTOR

Ref. No.	Part No.	Description	Remark
R736	△ 1-212-938-00	FUSIBLE	1.5 5% 1/2W F (K570/K670/K677ES NEW TYPE)
R752	1-249-441-11	CARBON	100K 5% 1/4W
R753	1-249-441-11	CARBON	100K 5% 1/4W
R754	1-249-441-11	CARBON	100K 5% 1/4W
R756	1-249-441-11	CARBON	100K 5% 1/4W
R757	1-249-441-11	CARBON	100K 5% 1/4W
R758	1-249-441-11	CARBON	100K 5% 1/4W
R774	1-249-422-11	CARBON	2.7K 5% 1/4W
R775	1-249-424-11	CARBON	3.9K 5% 1/4W
R802	1-249-425-11	CARBON	4.7K 5% 1/4W
R803	1-249-420-11	CARBON	1.8K 5% 1/4W
R804	1-249-412-11	CARBON	390 5% 1/4W
R805	1-249-427-11	CARBON	6.8K 5% 1/4W
R806	1-249-419-11	CARBON	1.5K 5% 1/4W
R807	1-259-452-11	CARBON	10K 5% 1/6W
R808	1-259-432-11	CARBON	1.5K 5% 1/6W
R809	1-249-425-11	CARBON	4.7K 5% 1/4W
R810	1-249-409-11	CARBON	220 5% 1/4W
R811	1-259-428-11	CARBON	1K 5% 1/6W
R812	1-259-448-11	CARBON	6.8K 5% 1/6W
R813	1-259-448-11	CARBON	6.8K 5% 1/6W
R814	1-249-417-11	CARBON	1K 5% 1/4W
R815	1-249-425-11	CARBON	4.7K 5% 1/4W
R816	1-249-425-11	CARBON	4.7K 5% 1/4W
R817	1-249-425-11	CARBON	4.7K 5% 1/4W
R818	1-249-433-11	CARBON	22K 5% 1/4W
R819	1-249-436-11	CARBON	39K 5% 1/4W
R820	1-249-429-11	CARBON	10K 5% 1/4W
R821	1-249-437-11	CARBON	47K 5% 1/4W
R825	△ 1-219-135-11	FUSIBLE	0.15 10% 1/4W (K570/K670/K677ES NEW TYPE)
R826	△ 1-219-137-11	FUSIBLE	0.33 10% 1/4W (K570/K670/K677ES NEW TYPE)
< VARIABLE RESISTOR >			
RV121	1-238-015-11	RES. ADJ. CARBON	4.7K
RV141	1-238-017-11	RES. ADJ. CARBON	22K
RV181	1-238-017-11	RES. ADJ. CARBON	22K
RV221	1-238-015-11	RES. ADJ. CARBON	4.7K
RV241	1-238-017-11	RES. ADJ. CARBON	22K
RV281	1-238-017-11	RES. ADJ. CARBON	22K
RV501	1-241-403-11	RES. VAR. CARBON	50K/50K (REC LEVEL)
RV502	1-238-904-11	RES. VAR. CARBON	50K/50K (BALANCE)
RV503	1-241-404-11	RES. VAR. CARBON	5K/5K (CALIBRATION REC LEVEL) (K670/K677ES)
RV504	1-238-015-11	RES. ADJ. CARBON	4.7K (K670/K677ES)
RV551	1-238-085-11	REA. VAR. CARBON	20K/20K (PHONE LEVEL)
RV581	1-241-046-11	RES. VAR. CARBON	5K (BIAS)

Ref. No.	Part No.	Description	Remark
< SWITCH >			
S501	1-572-154-11	SWITCH, ROTARY (DOLBY NR)	
S502	1-554-118-00	SWITCH, PUSH (1 KEY) (MPX FILTER)	
S503	1-572-708-11	SWITCH, ROTARY (INPUT)	
S763	1-571-520-11	SWITCH, SLIDE (TIMER)	
S801	1-554-118-00	SWITCH, PUSH (1 KEY) (POWER)	
< TRANSFORMER >			
T181	1-433-344-11	TRANSFORMER, BIAS OSCILLATION	
T281	1-433-344-11	TRANSFORMER, BIAS OSCILLATION	
T581	1-433-343-11	TRANSFORMER, BIAS OSCILLATION (K570)	
T581	1-433-380-11	TRANSFORMER, BIAS OSCILLATION (K670/K677ES)	
< CERAMIC >			
X701	1-577-359-21	VIBRATOR, CERAMIC 4.19MHz	
*****			
* 1-632-741-11 REAL MOTOR BOARD			
*****			
< CAPACITOR >			
C1051	1-124-907-11	ELECT	10uF 20% 50V
C1052	1-124-907-11	ELECT	10uF 20% 50V
C1053	1-164-159-11	CERAMIC	0.1uF 50V
< CONNECTOR >			
CN1051	* 1-564-499-11	PIN, CONNECTOR	6P
CN1052	* 1-564-718-11	PIN, CONNECTOR (SMALL TYPE)	2P
CN1053	* 1-564-718-11	PIN, CONNECTOR (SMALL TYPE)	2P
< RESISTOR >			
R1051	1-249-414-11	CARBON	560 5% 1/4W
*****			

<p><b>Note:</b> The components identified by mark <b>△</b> or dotted line with mark <b>△</b> are critical for safety. Replace only with part number specified.</p>	<p><b>Note:</b> Les composants identifiés par une marque <b>△</b> sont critiques pour la sécurité. Ne les remplacer que par une pièce portant le numéro spécifié.</p>
--	---

Ref. No.	Part No.	Description	Remark
		MISCELLANEOUS *****	
11	1-569-007-11	ADAPTOR, CONVERSION 2P (K570:E3)	
12	△ 1-551-188-XX	CORD, POWER (K570:E)	
12	△ 1-551-506-XX	CORD, POWER (K570:Canadian/ K677ES:US, Canadian)	
12	△ 1-555-465-00	CORD, POWER (K670:US)	
12	△ 1-555-795-00	CORD, POWER, EULO PLUG (K570:AEP, G/ K670:AEP, G)	
12	△ 1-556-035-00	CORD, POWER (K570:UK/K677ES:UK)	
125	* 1-608-268-00	PC BOARD, ERASE HEAD (K670/K677ES)	
D1051	8-719-980-85	DIODE SLF-325C	
HE1001	1-543-535-11	HEAD, MAGNETIC (ERASE) (K570)	
HE1001	1-543-836-11	HEAD, MAGNETIC (ERASE) (K670/K677ES)	
HRP1001	1-543-733-11	HEAD, MAGNETIC (REC/PB) (K570)	
HRP1001	1-543-834-11	HEAD, MAGNETIC (REC/PB) (K670)	
HRP1001	1-543-835-11	HEAD, MAGNETIC (REC/PB) (K677ES)	
M1051	X-3356-638-1	MOTOR (REEL R) ASSY	
M1052	X-3356-604-1	MOTOR (ASSIST) ASSY	
M1053	X-3356-635-1	MOTOR (CAPSTAN R2) ASSY (K670/K677ES)	
M1053	X-3356-646-1	MOTOR (CAPSTAN V1) ASSY (K570)	
S1001	1-466-238-11	ENCODER, ROTARY	
T901	△ 1-450-100-11	TRANSFORMER, POWER (K570:Canadian/ K670:US/K677ES:US, Canadian)	
T901	△ 1-450-101-11	TRANSFORMER, POWER (K570:E)	
T901	△ 1-450-399-11	TRANSFORMER, POWER (K570:AEP, G, UK/ K670:AEP, G/K677ES:UK)	
VS901	△ 1-570-307-11	SWITCH, VOLTAGE CHANGE (K570:E)	

\*\*\*\*\*

ACCESSORY & PACKING MATERIAL  
\*\*\*\*\*

- 1-559-533-11 CORD, CONNECTION
- \* 3-350-830-01 CUSHION
- \* 3-366-700-41 INDIVIDUAL CARTON (K677ES)
- \* 3-366-700-51 INDIVIDUAL CARTON (K670)
- \* 3-366-700-61 INDIVIDUAL CARTON (K570)
- 3-703-450-01 INSTRUCTION (K670:US/K677ES:US)
- \* 3-704-343-01 SHEET (STANDARD), PROTECTION
- 3-753-218-21 MANUAL, INSTRUCTION (ENGLISH, FRENCH)  
(K677ES)
- 3-753-363-11 MANUAL, INSTRUCTION (ENGLISH, FRENCH,  
SPANISH, PORTUGUESE) (K670:AEP)
- 3-753-363-21 MANUAL, INSTRUCTION (ENGLISH) (K670:US)
- 3-753-363-41 MANUAL, INSTRUCTION (GERMAN, DUTCH,  
SWEDISH, ITALIAN) (K670:AEP)
- 3-753-363-51 MANUAL, INSTRUCTION (GERMAN) (K670:G)
- 3-753-366-11 MANUAL, INSTRUCTION (ENGLISH, FRENCH,  
SPANISH, PORTUGUESE) (K570:Canadian, AEP, UK)
- 3-753-366-41 MANUAL, INSTRUCTION (GERMAN, DUTCH,  
SWEDISH, ITALIAN) (K570:AEP)
- 3-753-366-51 MANUAL, INSTRUCTION (GERMAN) (K570:G)
- 3-753-366-61 MANUAL, INSTRUCTION (ENGLISH, FRENCH,  
SPANISH, CHINESE) (K570:E)
- 3-793-481-13 INSTRUCTION (K670/K677ES)

Ref. No.	Part No.	Description	Remark
		<b>HARDWARE LIST</b>	
# 1	7-685-534-19	SCREW +BTP 2.6X8 TYPE2 N-S	
# 2	7-682-547-04	SCREW +BVTT 3X6 (S)	
# 3	7-685-646-79	SCREW +BVTP 3X8 TYPE2 N-S	
# 4	7-685-870-01	SCREW +BVTT 3X5 (S) (K670/K677ES)	
# 5	7-671-154-01	STENLESS BALL (K670/K677ES)	
# 6	7-628-253-00	SCREW +PS 2X4 (K670/K677ES)	
# 7	7-685-133-19	SCREW +BTP 2.6X6 TYPE2 N-S	
# 8	7-621-255-20	SCREW +BVTT 2X4 (S)	
# 9	7-621-772-20	SCREW +B 2X5 (K570)	
#10	7-621-772-70	SCREW +B 2X14 (K670/K677ES)	
#11	7-622-205-05	NUT M2 TYPE2 (K670/K677ES)	
#12	7-621-772-18	SCREW +B 2X4 (K670/K677ES)	
#13	7-621-775-10	SCREW +B 2.6X4 (K670/K677ES)	
#14	7-621-255-35	SCREW +BVTT 2X5 (S)	
#15	7-685-132-19	SCREW +BTP 2.6X5 TYPE2 N-S (K570)	
#16	7-682-647-09	SCREW +PS 3X6 (K670/K677ES)	

**Note:**  
The components identified by mark △ or dotted line with mark △ are critical for safety. Replace only with part number specified.

**Note:**  
Les composants identifiés par une marque △ sont critiques pour la sécurité. Ne les remplacer que par une pièce portant le numéro spécifié.



# TC-K570 / K670 / K677ES

## SONY<sup>®</sup> SERVICE MANUAL

*Canadian Model*  
*AEP Model*  
*UK Model*  
*E Model*  
*Australian Model*  
TC-K570

## SUPPLEMENT-1

File this supplement with the service manual.

*US Model*  
*AEP Model*  
TC-K670

*US Model*  
*Canadian Model*  
*UK Model*  
*Australian Model*  
TC-K677ES

For the TC-K570 and TC-677ES Service Manual released  
Previously, the Australian Model is added.  
Please utilize it since its contents are same as those  
of UK Model.

# TC-K570/K670/K677ES

## SONY SERVICE MANUAL

Canadian Model  
AEP Model  
UK Model  
E Model  
Australian Model  
TC-K570





### CORRECTION-1

Correct your service manual as shown below.

US Model  
AEP Model  
TC-K670

US Model  
Canadian Model  
UK Model  
Australian Model  
TC-K677ES

 : indicates corrected portion.

Page	INCORRECT			CORRECT	
	No.	Part No.	Description	Part No.	Description
29	8	3-367-791-01	PANEL, BACK (K670 : US)	3-367-971-01	PANEL, BACK (K670 : US)
	8	3-367-791-11	PANEL, BACK (K670 : AEP, G)	 3-367-971-21	PANEL, BACK (K670 : AEP, G)
	8	3-367-792-01	PANEL, BACK (K570 : AEP, G)	 3-367-972-11	PANEL, BACK (K570 : AEP, G)
	8	3-367-792-21	PANEL, BACK (K570 : UK)	 3-367-972-21	PANEL, BACK (K570 : UK)
	8	3-367-792-31	PANEL, BACK (K570 : Canadian)	 3-367-972-31	PANEL, BACK (K570 : Canadian)
	8	3-367-792-41	PANEL, BACK (K570 : E)	 3-367-972-41	PANEL, BACK (K570 : E)

# TC-K570/K670/K677ES

## SONY SERVICE MANUAL

*Canadian Model  
AEP Model  
UK Model  
E Model  
TC-K570*

### CORRECTION- 2

Correct your service manual as shown below.

*US Model  
AEP Model  
TC-K670*

*US Model  
Canadian Model  
UK Model  
TC-K677ES*

 : indicates corrected portion.

Page	INCORRECT			CORRECT		
	No.	Part No.	Description	No.	Part No.	Description
29	125	3-564-121-00	SPRING, COMPRESSION (K670/K677ES)	 127	3-567-121-00	SPRING, COMPRESSION (K670/K677ES)