

# TC-K679ES/K690

## SERVICE MANUAL

US Model

TC-K679ES

TC-K690

Canadian Model

UK Model

TC-K679ES

AEP Model

TC-K690

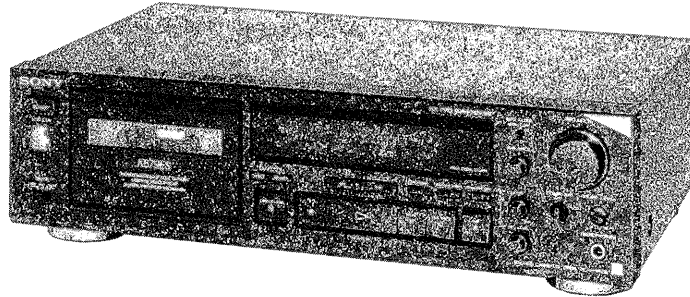

Dolby noise reduction manufactured under license from Dolby Laboratories Licensing Corporation. "DOLBY" and the double-D symbol  are trademarks of Dolby Laboratories Licensing Corporation.

Photo:TC-K679ES

### SPECIFICATIONS

Recording system 4-track 2-channel stereo  
Fast winding time Approx. 90 sec. (with Sony C-60 cassette)  
Bias AC bias  
Heads Erasing head × 1 (S&F head)  
Recording head × 1 (SD head)  
Playback head × 1 (LA head) (K679ES)  
Playback head × 1 (SD head) (K690)  
Motors Capstan motor × 1 (DC servo motor)  
Reel motor × 1 (DC motor)  
ASIST (mechanical drive) motor × 1 (DC motor)

Signal-to-noise ratio (at peak level)

Cassette (Dolby NR OFF)	Type IV (Sony Metal-Select/S)	Type II (Sony UX-S)	Type I (Sony HF-S)
	60 dB	59 dB	57 dB

Measured at peak level weighted without NR. The S/N is improved by about 15 dB at 500 Hz and by about 20 dB about 1 kHz with Dolby-C NR on, and by 5 dB at 1 kHz and by 10 dB about 5 kHz with Dolby-B NR on.

Harmonic distortion

0.4% (with Sony Type I, 160 nWb/m, 315 Hz, 3rd H.D.)  
1.5% (with Sony Type IV, 250 nWb/m, 315 Hz, 3rd H.D.)

Frequency response (Dolby NR OFF)

Type IV cassette (Sony Metal-Select/S)	20-21,000 Hz (± 3dB,IEC) (K679ES) 20-20,000 Hz (± 3dB,IEC) (K690) 20-16,000 Hz [± 3dB (-4dB recording)]
Type II cassette (Sony UX-S)	20-19,000Hz (± 3dB,IEC) (K679ES) 20-18,000 Hz (± 3dB,IEC) (K690)
Type I cassette (Sony HF-S)	20-17,000Hz (± 3 dB,IEC)

Wow and flutter  
±0.09% W.Peak (IEC)  
0.05% W.RMS (NAB)  
±0.14% W.Peak (DIN)

Model Name Using Similar Mecanism	TC-K677ES/K670	
Tape Transport	TC-K679ES	TCM-200V9
Mechanism Type	TC-K690	TCM-200V10

### Inputs

Line inputs (phono jacks)	Sensitivity	0.16 V
	Input impedance	47 kilohms

### Outputs

Line outputs (phono jacks)	Rated output level	0.5 V at a load impedance of 47 kilohms
	Load impedance	Over 10 kilohms
Headphones (stereo phone jack)	Output level	0 — 3 mW at a load impedance of 32 ohms

### General

Power requirements 120V AC, 60Hz : K679ES (US,Canadian) K690 (US)  
240V AC, 50Hz : K679ES (UK)  
220 - 230V AC, : K690 (AEP, Germany)  
(or 240V AC adjustable by Sony personnel), 50/60Hz.

Power consumption 19 W

Dimensions Approx. 430 × 123 × 300 mm (w/h/d)  
(17 × 4<sup>7</sup>/<sub>8</sub> × 11<sup>7</sup>/<sub>8</sub> inches)  
including projecting parts and controls

Weight Approx. 4.9 kg (10 lbs 13 oz)

### Supplied accessories

Audio connecting cords (2)

Design and specifications are subject to change without notice.

STEREO CASSETTE DECK  
**SONY**®

TABLE OF CONTENTS

<u>Section</u>	<u>Title</u>	<u>Page</u>
1. GENERAL .....		3
2. DISASSEMBLY .....		4
3. PIN DESCRIPTION .....		7
4. ADJUSTMENTS		
4-1. Mechanical Adjustments .....		8
4-2. Electrical Adjustment .....		11
5. DIAGRAMS		
5-1. Circuit Boards Location .....		15
5-2. IC Block Diagram .....		15
5-3. Printed Wiring Boards .....		17
5-4. Schematic Diagram .....		21
5-5. Semiconductor Lead Layouts .....		26
6. EXPLODED VIEWS		
6-1. Chassis Section .....		27
6-2. Front Panel Section .....		28
6-3. Mechanism Section 1 .....		29
6-4. Mechanism Section 2 .....		30
7. ELECTRICAL PARTS LIST .....		31

MODEL IDENTIFICATION  
- Specification Label -

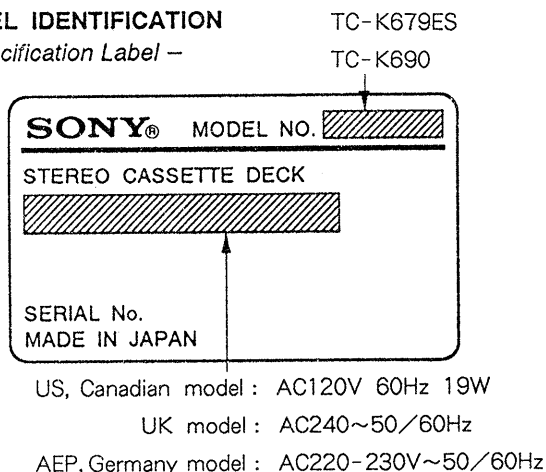

SAFETY-RELATED COMPONENT WARNING!!

COMPONENTS IDENTIFIED BY MARK OR DOTTED LINE WITH MARK ON THE SCHEMATIC DIAGRAMS AND IN THE PARTS LIST ARE CRITICAL TO SAFE OPERATION. REPLACE THESE COMPONENTS WITH SONY PARTS WHOSE PART NUMBERS APPEAR AS SHOWN IN THIS MANUAL OR IN SUPPLEMENTS PUBLISHED BY SONY.

SAFETY CHECK-OUT

After correcting the original service problem, perform the following safety check before releasing the set to the customer:

Check the antenna terminals, metal trim, "metallized" knobs, screws, and all other exposed metal parts for AC leakage. Check leakage as described below.

LEAKAGE TEST

The AC leakage from any exposed metal part to earth ground and from all exposed metal parts to any exposed metal part having a return to chassis, must not exceed 0.5 mA (500 microamperes). Leakage current can be measured by any one of three methods.

1. A commercial leakage tester, such as the Simpson 229 or RCA WT-540A. Follow the manufacturers' instructions to use these instruments.
2. A battery-operated AC milliammeter. The Data Precision 245 digital multimeter is suitable for this job.
3. Measuring the voltage drop across a resistor by means of a VOM or battery-operated AC voltmeter. The "limit" indication is 0.75 V, so analog meters must have an accurate low-voltage scale. The Simpson 250 and Sanwa SH-63Trd are examples of a passive VOM that is suitable. Nearly all battery operated digital multimeters that have a 2V AC range are suitable. (See Fig. A)

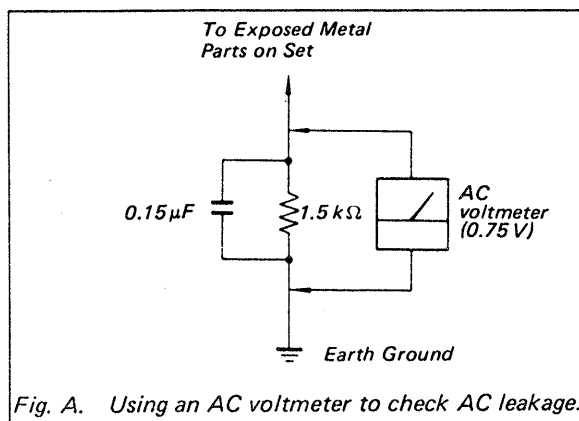

Fig. A. Using an AC voltmeter to check AC leakage.

ATTENTION AU COMPOSANT AYANT RAPPORT  
À LA SÉCURITÉ!

LES COMPOSANTS IDENTIFIÉS PAR UNE MARQUE SUR LES DIAGRAMMES SCHÉMATIQUES ET LA LISTE DES PIÈCES SONT CRITIQUES POUR LA SÉCURITÉ DE FONCTIONNEMENT. NE REMPLACER CES COMPOSANTS QUE PAR DES PIÈCES SONY DONT LES NUMÉROS SONT DONNÉS DANS CE MANUEL OU DANS LES SUPPLÉMENTS PUBLIÉS PAR SONY.

This section is extracted from instruction manual.

## SECTION 1 GENERAL

### Hooking Up the System

#### Front Panel

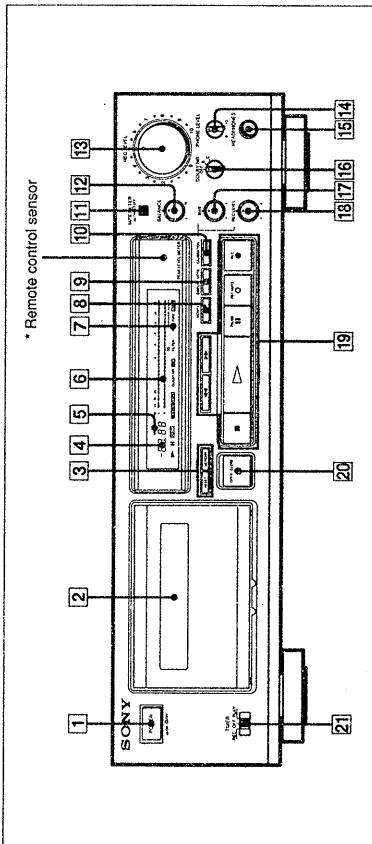

\* Remote control sensor

For details, refer to the page number indicated in parenthesis.

- 1 POWER switch
- 2 Cassette holder
- 3 Counter buttons
- 4 RESET button (page 10)
- 5 MEMORY COUNTER (page 10)
- 6 MEMORY indicator
- 7 PEAK LEVEL METER (page 12)
- 8 TAPE TYPE indicator
- 9 MONITOR button (page 13)
- 10 DISPLAY MODE button (page 14)
- 11 CALIBRATION button (page 14)
- 12 MPX FILTER button (page 11)
- 13 BALANCE control (page 11)
- 14 REC (recording) LEVEL control (pages 11 and 13)
- 15 PHONE (headphones) LEVEL control (page 7)
- 16 HEADPHONES jack (stereo phone jack) (page 7)
- 17 DOLBY NR (noise reduction) switch (pages 7 and 11)
- 18 BIAS control (pages 14 and 15)
- 19 REC (recording) LEVEL control for calibration (pages 14 and 15)
- 20 Tape operation buttons
  - ◀ (rewind) button
  - ▶ (fast-forward) button
  - (stop) button
  - ⏮ (play) button
  - ⏭ PAUSE button
  - ⏹ REC MUTE (record muling) button (page 16)
  - ⏻ REC (recording) button
  - ⏺ OPEN/CLOSE button
  - ⏸ TIMER switch (page 16)
- 21 Remote control sensor
  - A remote commander that came with a Sony amplifier or receiver; if it has the mark and cassette deck control capability.
  - An optional Sony remote commander with the mark and cassette deck control capability.

#### Before You Begin

- Turn off the power to all equipment to be connected before making any connection.
- Note that the red plug of the supplied connecting cord is for right-channel (R) connection and the white plug for left-channel (L) connection.
- The connecting cords should be fully inserted into the jacks. A loose connection may cause hum pickup.

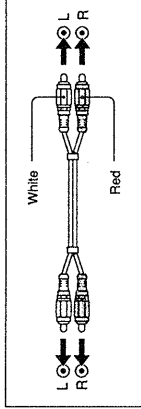

#### Hook-up Example

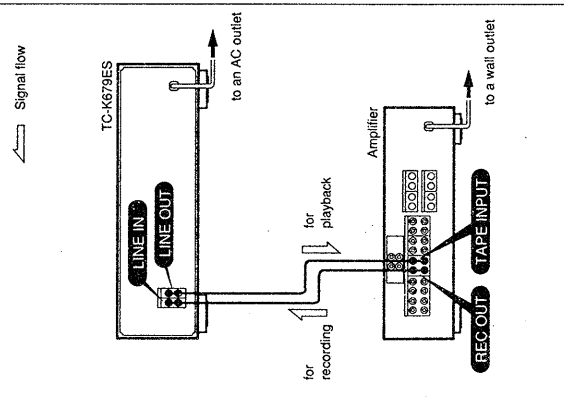

#### Hook-up for Tape Dubbing

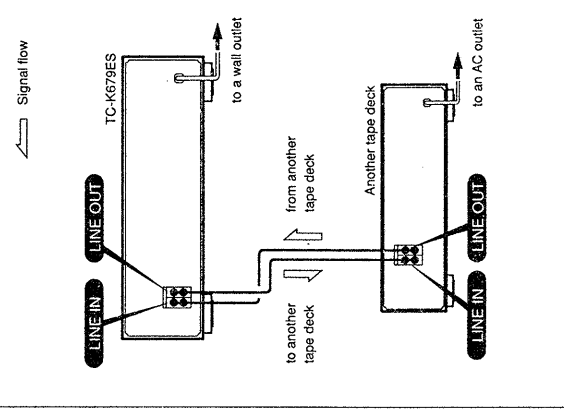

## SECTION 2 DISASSEMBLY

NOTE: Follow the disassembly procedure in the numerical order given.

### MECHANISM BLOCK

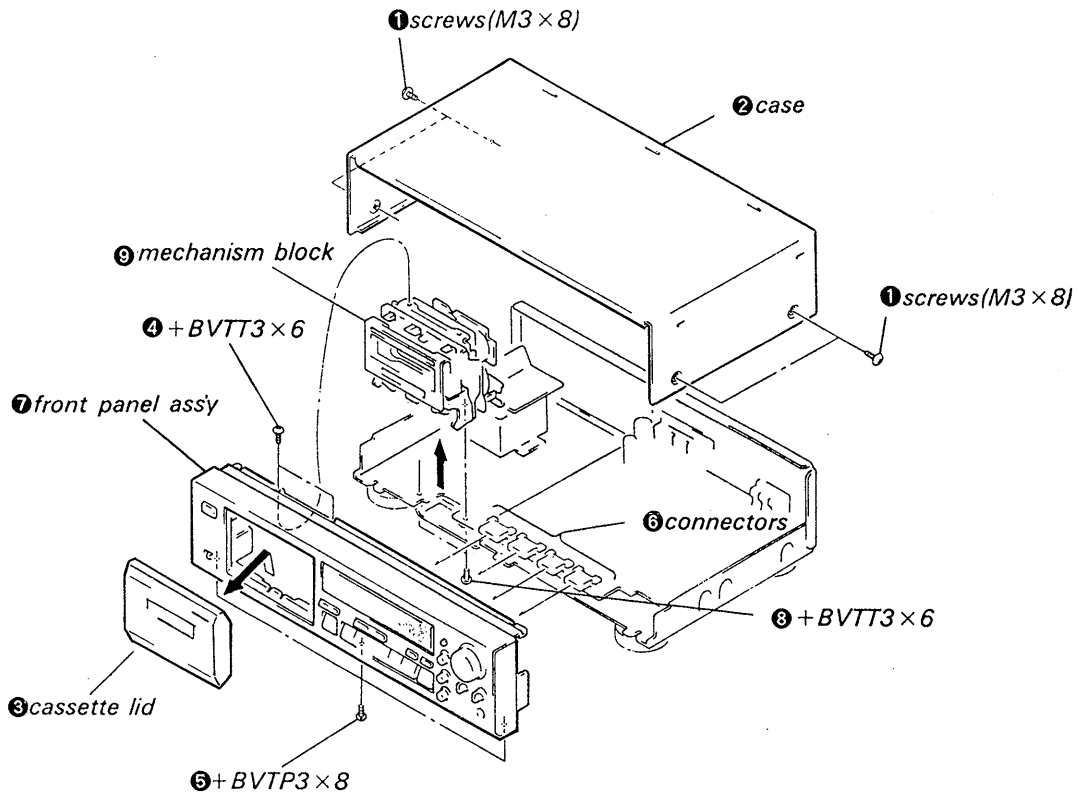

### CASSETTE HOLDER

5 Push lever (lifter) in the direction of arrow and remove cassette holder.

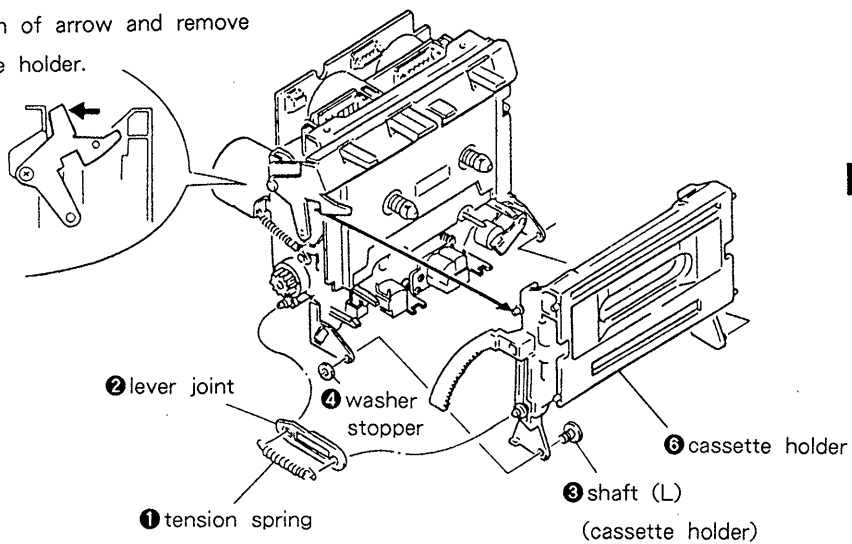

**ORNAMENTAL PLATE**

② Push lever (lifter) in the direction of arrow and remove ornamental plate.

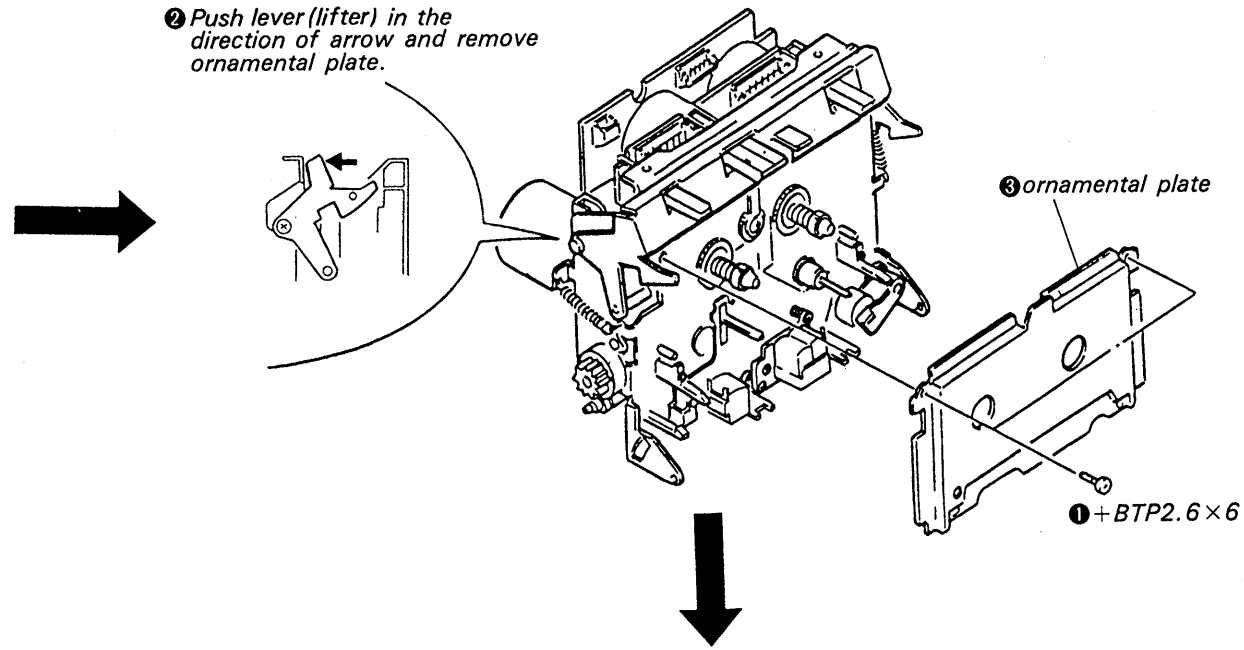

**CAPSTAN MOTOR / FLYWHEEL**

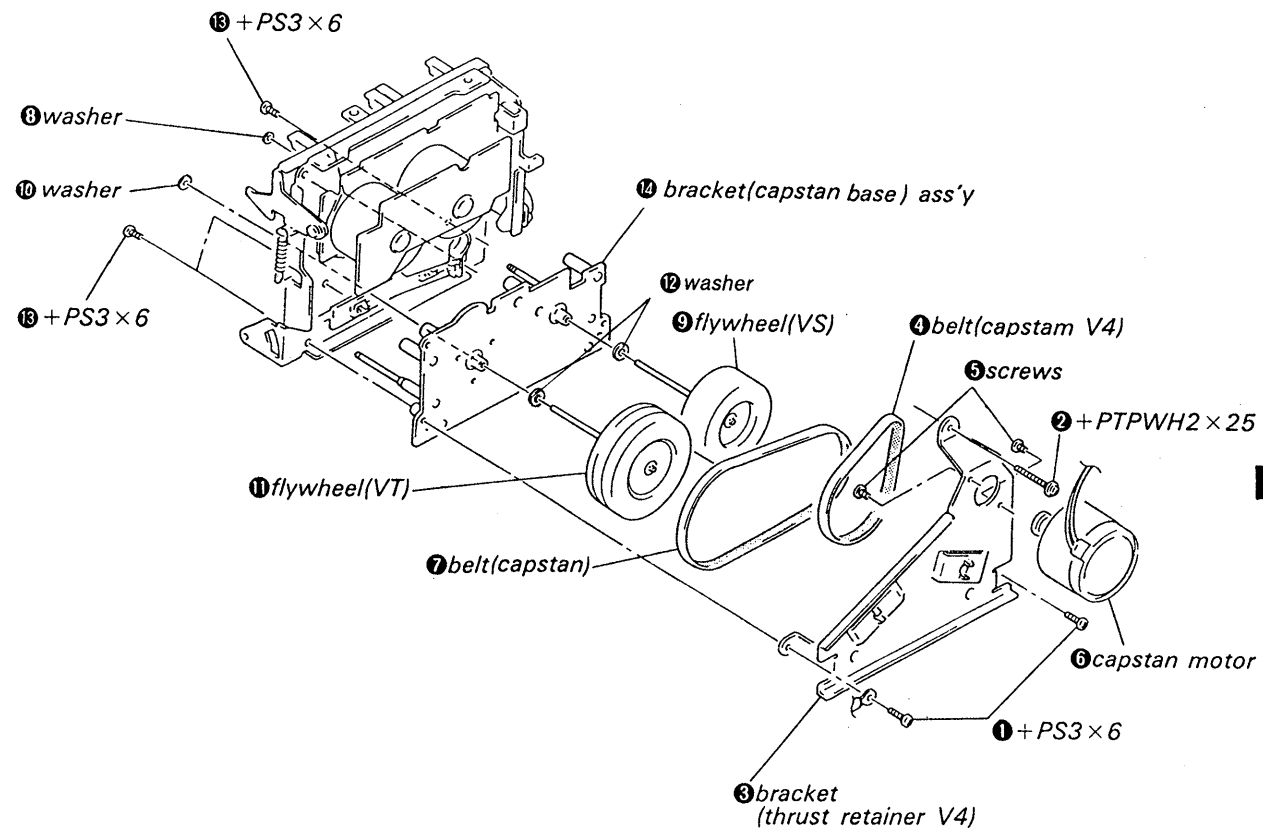

**REEL AND ASSIST MOTORS**

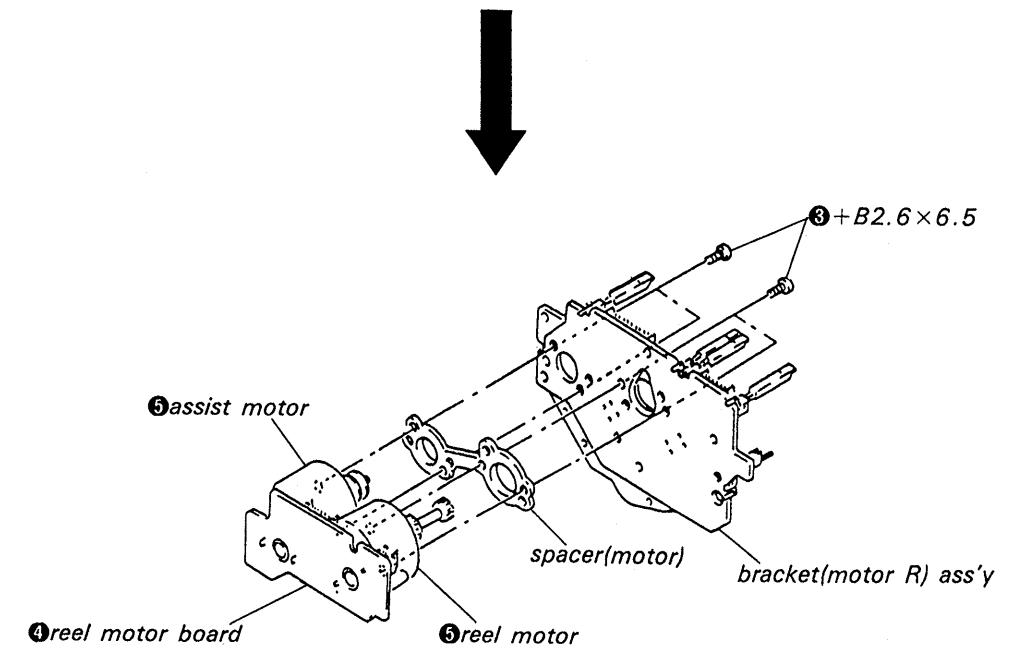
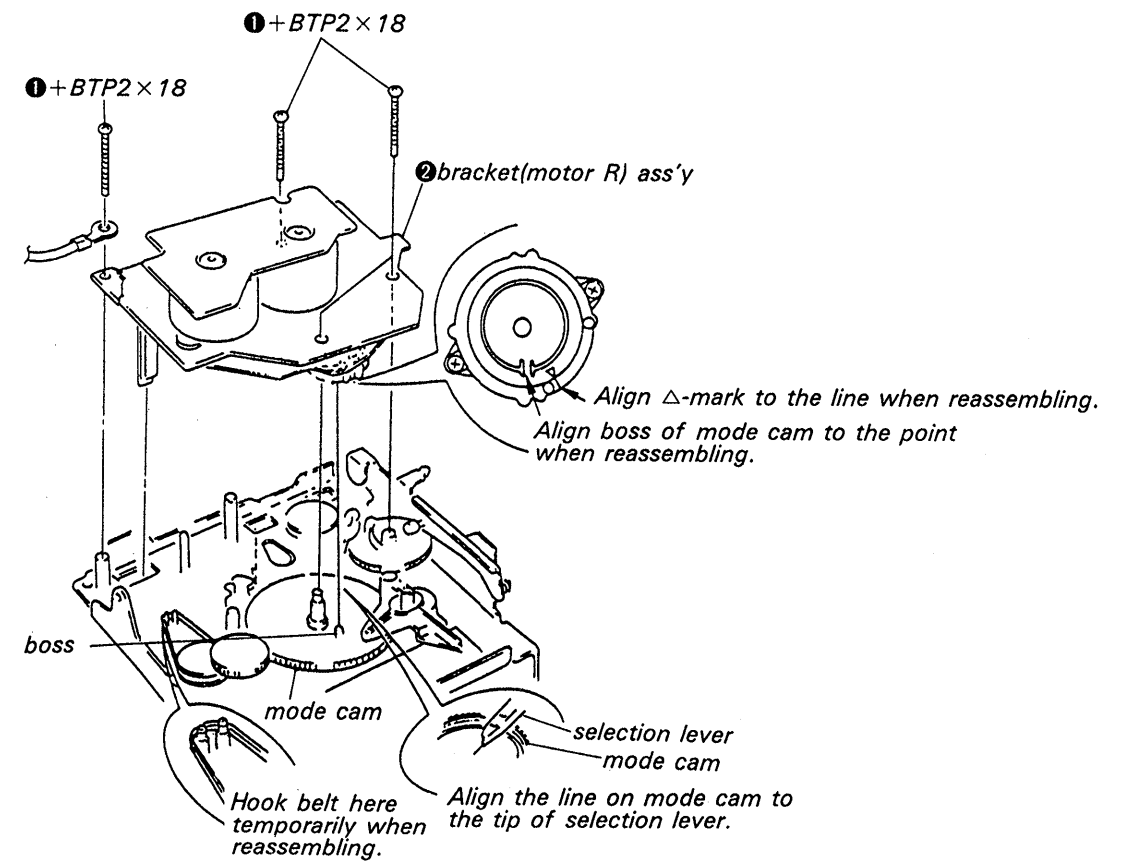

## SECTION 3

### PIN DESCRIPTION

#### ·IC701 M50941-728SP(MICRO COMPUTER)

The M50941-728SP function are described below.

Pin No.	Pin Name	I/O	Description
1	V <sub>REF</sub>	I	Internal A/D port reference voltage input.
2	KEY 7	I	Key input port. 0V = OPEN/CLOSE, 1V = STOP, 2V = REW, 3V = FF, 4V = REC.
3	KEY 6	I	key input port. 0V = PLAY, 1V = PAUSE, 2V = REC MUTE.
4	KEY 5	I	Key input port. 0V = RESET, 1V = MEMORY, 2V = DISPLAY MODE, 3V = MONITOR.
5	METER-L	I	Signal input for level meter-L.
6	METER-R	I	Signal input for level meter-R.
7	TIMER	I	Timer REC/PLAY switch input. 0V = TIMER REC, 1V = TIMER PLAY, 2V = OFF.
8	T.PULSE	I	Take-up reel base sensor input.
9	S.PULSE	I	Supply reel base sensor input.
10	AMS.SIG	I	AMS signal input. No song detected = Low. Song detected = High.
11	BIAS	O	Bias oscillation on and off control.
12	MO3V	O	Motor speed control. STOP/PLAY = Low, FF/REW = High.
13	MO4.5V	O	Motor speed control. STOP/PLAY = High, FF/REW = Low.
14	MO-FWD	O	Reel motor rotates.
15	MO-REV	O	Reel motor rotates in reverse.
16	MO-DOWN	O	Head base DOWN output of the mechanical block.
17	MO-UP	O	Head base UP output of the mechanical block.
18	HALF-SW	I	HALF switch input of the mechanical block.
19	REC-SW	I	REC switch input of the mechanical block.
20	DOOR-SW	I	DOOR switch input of the mechanical block.
21	CLOSE-SW	I	CLOSE switch input of the mechanical block.
22	OPEN-SW	I	OPEN switch input of the mechanical block.
23	POWER-OUT	O	"Low" for power off procedure after POWER switch is turned off.
24	POWER-IN	I	Power(AC) off detection.
25	SIRCS	I	Remote control signal input.
26	V <sub>SS</sub>	-	GND
27	RESET	I	System reset input.
28	XI	I	Clock input(4.19MHz).
29	XO	O	Clock output.
30	XCI	-	Not used.
31	XCO	-	Not used.
32	V <sub>SS</sub>	-	GND
33	-	-	Not used.
34	PAT3	I	Rotary encoder input to detect the position of the head base of the mechanical block.
35	3	I	
37	PAT0	I	
38	-25V	-	Power supply for driving the fluorescent indicator tube.
39	FL-p	O	Segment data output for the fluorescent indicator tube FL751.
40	1	I	
54	FL-a	O	Common data output for the fluorescent indicator tube FL751.
55	FL-G5	O	
56	1	I	
59	FL-G1	O	
60	MONITOR	O	Source monitor control. Low = TAPE, High = SOURCE.
61	REC-MUTE	O	REC MUTE control. Low = MUTE.
62	LINE-MUTE	O	LINE MUTE control. Low = MUTE.
63	AV <sub>CC</sub>	-	Analog power supply(+5V).
64	V <sub>CC</sub>	-	Power supply(+5V).

## SECTION 4 ADJUSTMENTS

### 4-1. MECHANICAL ADJUSTMENTS

#### PRECAUTION

1. Clean the following parts with a denatured-alcohol-moistened swab:
 

record/playback head	pinch roller
erase head	rubber belts
capstan	idler
2. Demagnetize the record/playback head with a head demagnetizer.
3. Do not use a magnetized screwdriver for the adjustments.
4. After the adjustments, apply suitable locking compound to the parts adjusted.

#### Tape Path Adjustment

**Note :** When using the adjustment methods for other than replacement reasons, please do not tamper unnecessarily with the adjustment screws or the erasehead because either the supply pinch roller guide or the record/playback head will be made the standard tape paths. Moreover, when it is necessary to adjust and replace two or more of any of the heads and/or pinch rollers, replace them one by one, completely taking out the first tape path, and then replacing the second one.

#### Preparation :

1. Mirror cassette CQ009C 8-909-708-01  
(or CQ012C 8-909-708-02)

If one does not have this, cut out the sections of a 120-minute cassette shell as indicated below and use that cassette.

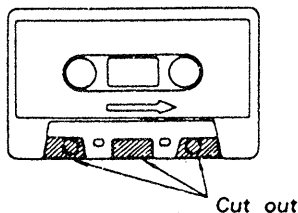

2. Phillips screwdriver (medium-size) :  
For the head adjustment screws  
Blade-type screwdriver (large-size) :  
For the supply pinch roller adjustment screws
3. Pen light
4. WS-48B (3 kHz, 0 dB)
5. P-4-A100 (10 kHz, -10 dB)

**Adjustment Position :** As seen from the cassette, side (top) and MD as seen head on (bottom).

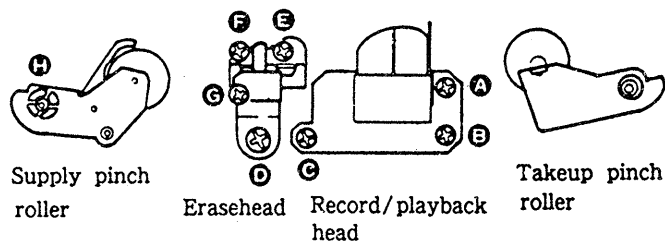
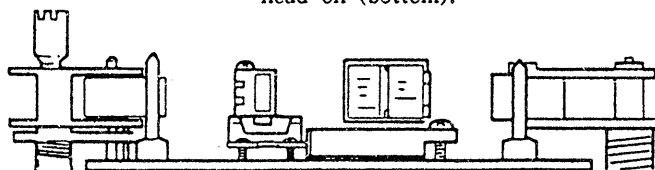

**Definition of Terms :** The figures are of a record/playback head.

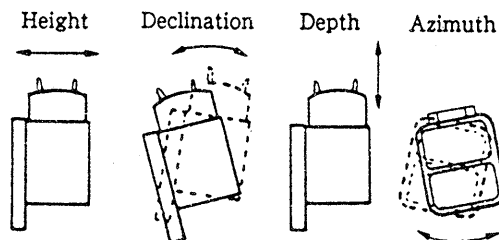

**Adjustment Method :**

**Supply Pinch Roller**

**Note :** Only perform this adjustment when the supply pinch roller is to be replaced.

1. Insert the mirror cassette and put the unit in record/playback mode.
2. Check to see whether the tape is curling at the record/playback head guide or the pinch roller guide.  
If it is curling, remove the curl by adjusting the  $\text{Ⓜ}$  tape curl adjustment screw. Then, check that the tape is running past the middle of the erasehead.

**Record/playback Head**

**Note :** Only perform this adjustment when the record /playback head is to be replaced.

1. Insert the mirror cassette and put the unit in record/playback mode.
2. **(Height Adjustment)** Check to see if the tape is curling at the tape guide of the head. If it is curling, tighten screws  $\text{Ⓐ}$ ,  $\text{Ⓜ}$ , and  $\text{Ⓢ}$ , respectively by the same angle, moving the head so that it remains at the same angle throughout the procedure. If it curls on the bottom side of the mirror cassette (actually the inner side), tighten all the screws equally ; but loosen them if the tape begins to curl on the top side (outer side).

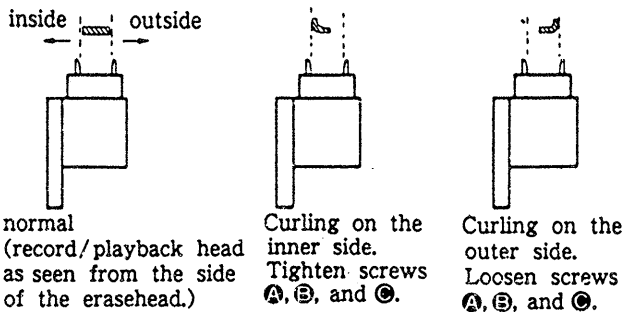

3. **(Declination Adjustment)** While in the record / playback position, set the back tension to 0 (wind the supply reel with something thin like a pencil in a counterclockwise direction) and make sure there is no curling or shifting (shifting up / shifting down) at the guide of the record / playback head.

Because shifting can only occur due to a difference in the width of the tape and that of the tape guides (curling will otherwise occur), it is necessary to pay close attention since it can be easily overlooked. When there is a shift, tighten screws  $\text{Ⓜ}$  and  $\text{Ⓢ}$  equally and change the declination of the head. If the tape is shifting up, tighten the screws, and if it is shifting down, loosen them.

4. Repeat the adjustments in steps 2 and 3 and fine adjust the height and the declination.
5. **(Preliminary Azimuth Adjustment)**  
After demagnetizing and cleaning the adjustment head, play back WS-48B (3 kHz, 0 dB). Turn screw  $\text{Ⓢ}$  so that the reading on the level meter of the unit or that of the level meter connected to LINE OUT is maximized. If the screw is turned at least half a revolution, repeat the adjustments from step 1.
6. **(Tape Path Check)** Connect the oscilloscope to LINE OUT and play back P-4-A100 (10 kHz, -10 dB) to display a resurge waveform. After 20 seconds of record / playback (after the tension within the loop has been increased sufficiently), make sure the variation in the resurge is within  $\pm 90$  degrees (within  $\pm 45$  degrees is desired). If the variation is greater than this, it is because the declination and/or the height adjustment is not perfect. Repeat the adjustments from step 1.

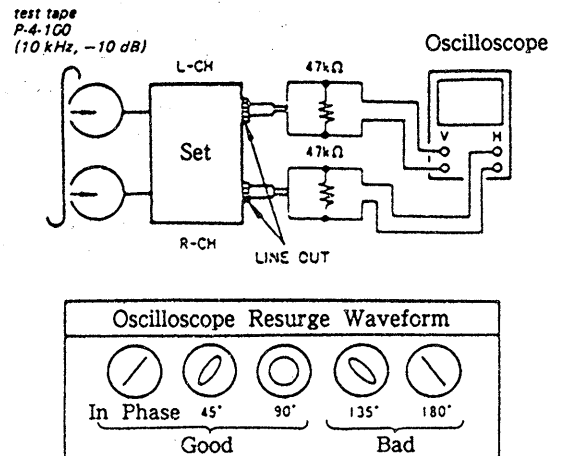



## Erasehead

**Note:** Only perform this adjustment when the erasehead is to be replaced.

1. Insert the mirror cassette and put the unit in record/playback mode.
2. (**Azimuth Adjustment**) Adjust the azimuth of the erasehead by adjusting screws  $\text{Ⓔ}$  and  $\text{Ⓕ}$  so that the tape runs as evenly as possible.

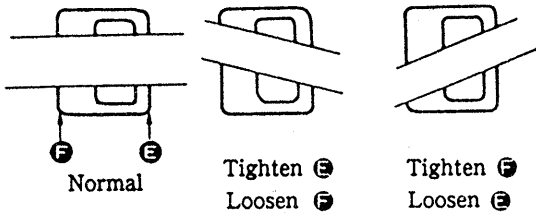

(The erasehead as seen when erasing the mirror cassette.)

3. (**Height adjustment**) Turn screws  $\text{Ⓓ}$ ,  $\text{Ⓔ}$ , and  $\text{Ⓕ}$  all by the same angle so that the portions of the erasehead visible at top and bottom are nearly of equal width. If the width at the top is greater, tighten the screws; if the width at the bottom is greater, loosen the screws.

Erasehead (The erasehead as seen through the mirror cassette.)

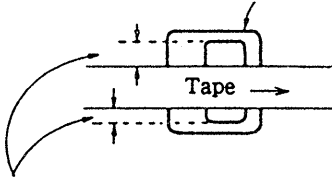

Make these the same width.

4. (**Declination Adjustment**) Leaving it in the playback position, put the back tension to 0 and make certain the erasehead part and supply pinch roller guide part do not shift. If there is a shift, turn the screw  $\text{Ⓓ}$  and change the declination. Looking at it using the mirror cassette, if the tape shifts up, tighten the screw, and if it shifts down, loosen the screw.
5. Repeat the adjustments beginning with step 2 and fine adjust the height and declination. And make sure the tape does not curl up on the pinch roller guide or the guide part of the record/playback head.
6. (**Depth Adjustment**) In order to make the entire head play the tape smoothly, and to make sure the depth of the erasehead is neither too shallow nor too deep, loosen screw  $\text{Ⓔ}$  a bit.

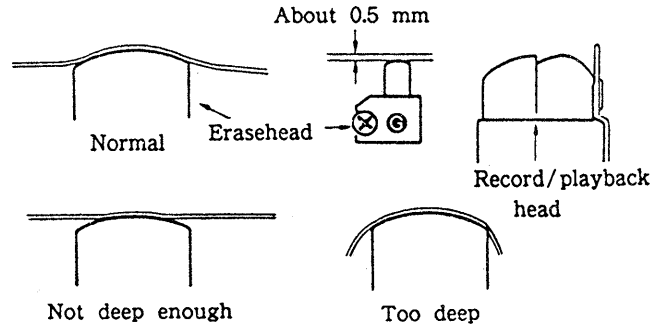

## Check

1. Check to make sure that there are no curls or shifts throughout the whole tape path and that the tape runs smoothly.
2. Reapply the locking compound to the adjusted screws. (The locking compound should only be applied to screw  $\text{Ⓔ}$  after the azimuth has been adjusted.)

## TORQUE MEASUREMENT

Torque	Torque meter	Meter reading
FWD	C Q-102C	28-60 g · cm (0.39-0.83 oz · inch)
FWD Back tension	C Q-102C	7-11 g · cm (0.097-0.15 oz · inch)
FF, REW	C Q-201B	85-90 g · cm (0.9-1.25 oz · inch)

## Pinch Roller Pressing Force Measurement

Mode: playback

Hook needle of the tension gauge to the pinch roller shaft and push back pinch roller to detach it from capstan. Then, return it gradually to capstan and read the gauge when the pinch roller begins turning.

### Standard Limits:

Tape-up side: 270-350 g (9.5-120 oz)

Supply side: 180-280 g (6.4-9.9 oz)

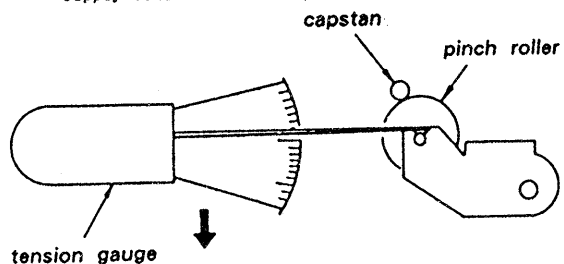

## 4-2. ELECTRICAL ADJUSTMENTS

**Note:** The adjustment should be performed in the order given in the service manual. As a rule, adjustments about playback should be performed before those about recording. The adjustments should be performed before for both L-CH and R-CH.

- Switches and controls should be set as follows unless otherwise specified.
  - DOLBY NR switch: OFF
  - MPX FILTER switch: OFF
  - MONITOR switch: Tape
- Standard Record:
  - Deliver the standard input signal level to the input jack and set the REC LEVEL control to obtain the standard output signal level.

### — Record Mode —

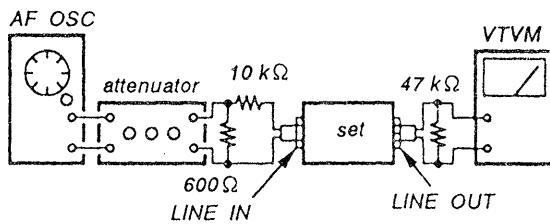

### Standard Input Level

input terminal	LINE IN
source impedance	10 kΩ
input level	0.5V ( - 3.8dB)

### Standard Output Level

output terminal	LINE OUT
load impedance	47 kΩ
output level	0.5V ( - 3.8dB)

### Test Tape

Type	Signal	Used for
P-4-A100	10 kHz, - 10 dB	Azimuth Adjustment
P-4-L300	315 Hz, 0 dB	PB Level Adjustmet
WS-48B	3 kHz, 0 dB	Tape Speed Adjustment

### Test Mode

This set will get into test mode by shorting the pins of CNE702 (TEST) on MA I N board before turning the power on.

### Record/Playback Head Azimuth Adjustment

#### Procedure:

- Mode: FWD playback

Test tape  
P-4-A100  
(10 kHz, - 10 dB)

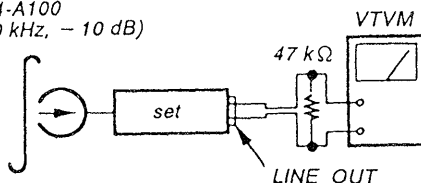

- Turn the adjustment screw for the maximum output levels. If these levels do not match, turn the adjustment screw until both of output levels match together within 1 dB.

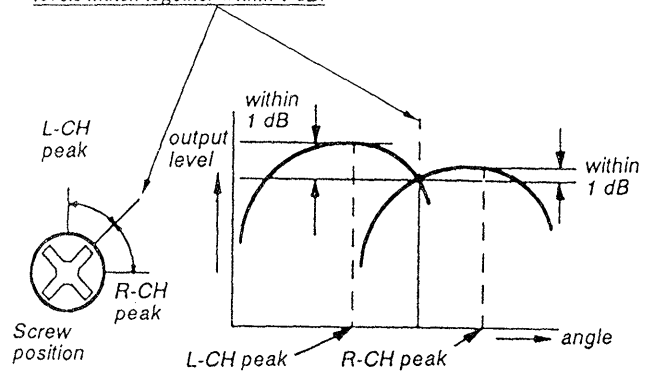

- Phase Check  
Mode: playback

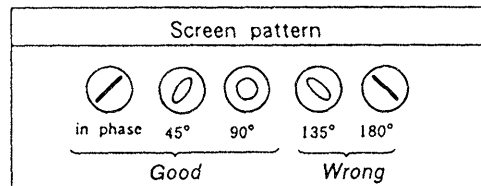
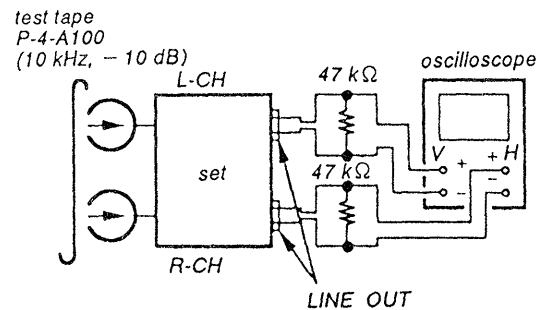

- After the adjustment, lock the screws with locking compound.

Adjustment Location: Record/Playback head

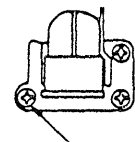

Adjustment screw

## Tape Speed Adjustment

### Setting:

Test pin CNE702: short

### Procedure:

Mode: playback

test tape  
WS-48B  
(3 kHz, 0 dB)

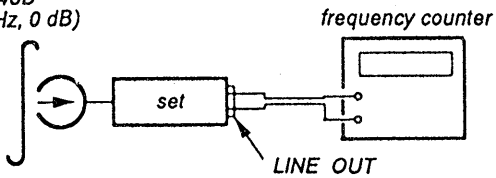

1. Set to FWD playback mode.
2. Adjust motor rear side (variable resistor) so that the frequency counter reading becomes  $3,000 \pm 15$  Hz.

Adjustment Location : motor rear side (M1053)

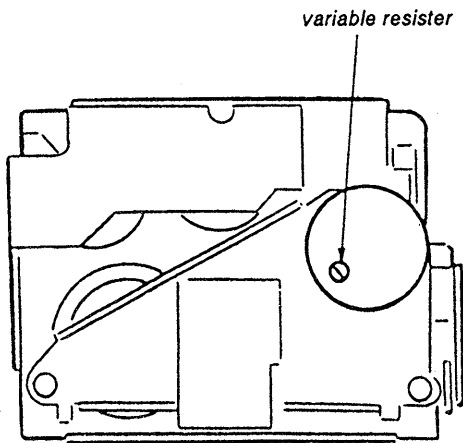

## Playback Level Adjustment

### Procedure:

Mode: playback

test tape  
P-4-L300  
(315 Hz, 0 dB)

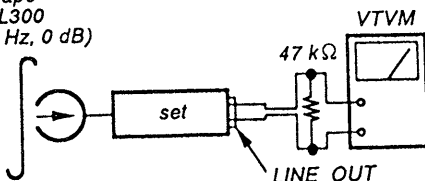

Adjust RV121 (L-ch) and RV221 (R-ch) so that the reading on VTVM meets the adjustment limits below.

### Adjustment Limits:

LINE OUT level:  $-8.2\text{dB}$  to  $-7.2\text{dB}$  (0.301 to 0.338V)

Level difference between channels: less than 0.5 dB

Check that the LINE OUT level does not change even if Playback and Stop operation is repeated several times.

Adjustment Location: MAIN board

## Bias Consumption Current Adjustment

### Procedure:

LINE IN  
(no signal)

CS - 413 black tape

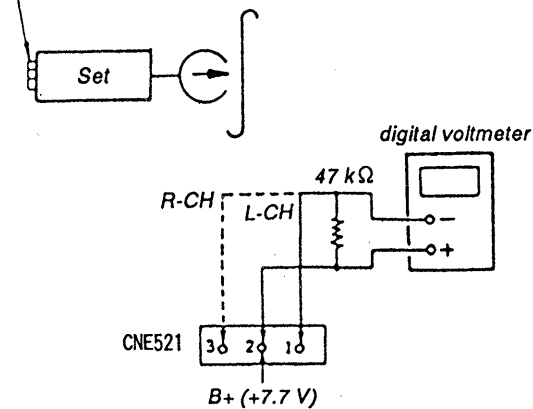

1. Set RV181(L-CH) and RV281(R-CH) to mechanical center and turn the set recording mode.
2. Connect digital voltmeter as shown by the following table.
3. Adjust the following transformers for the minimum readings on the digital voltmeter.

	Mesurement Point	Adjustment Part	Value
L-ch	① and ②, CNE521	T181	not more than 200mV
R-ch	③ and ②, CNE521	T281	

Adjsutment Location: MAIN (A) board

## Record Bias Adjustment

### Setting:

REC LEVEL control: Standard Record (see page 11)

test pin CNE702: short

### Procedure:

1. Mode: record

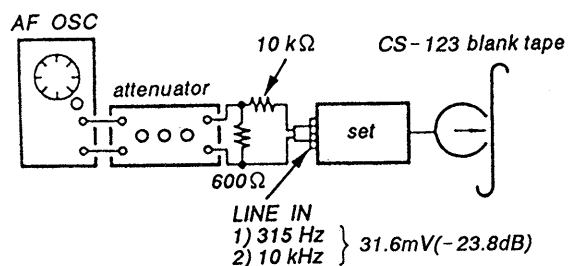

2. Mode: playback

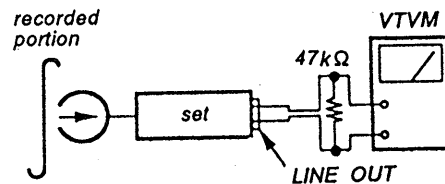

Playback the signal recorded in step 1.

Confirm that the 10 kHz playback output is  $0 \pm 0.5$  dB relative to the 315 Hz output. If necessary, adjust RV181 (L-ch) and RV281 (R-ch) for repeat the steps given above.

Adjustment Location: MAIN BOARD

## Record Level Adjustment

### Setting:

REC LEVEL control: Standard Record (see page 11)  
test pin CNE702 : short

### Procedure:

1. Mode: record

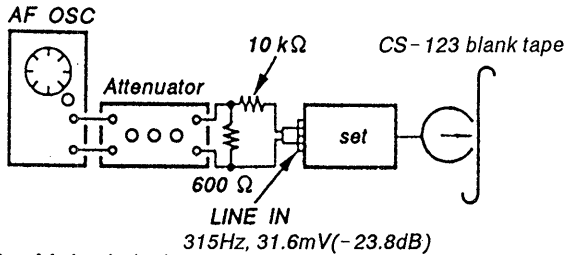

2. Mode: playback  
recorded portion

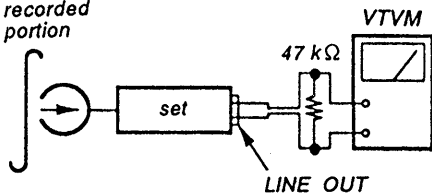

3. Playback the signal recorded in step 1.  
Confirm that the signal level is within the adjustment limits below. If necessary, adjust RV141 (L-ch) and RV241 (R-ch) repeat the step 1 - 2.

**Adjustment Limits:**  $-23.8\text{dB} \pm 0.5\text{dB}$  (29 to 33.4mV)

**Adjustment Location:** MAIN board

## Erase Current Adjustment

1. Mode : record

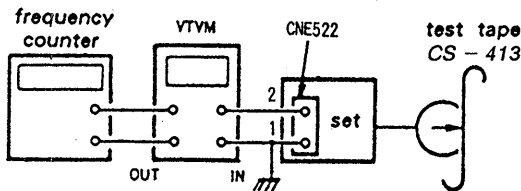

2. Adjust RV504 so that the reading on VTVM is 110mV (erase current=110mA.)
3. And then confirm that the reading on the frequency counter is 160kHz.

### Adjustment Limits:

Erase current: 105mA to 110mA

Frequency:  $160 \pm 6\text{kHz}$

**Adjustment Location:** MAIN board

## Record EQ (IV) Adjustment

### Setting:

REC LEVEL control: Standard Record (See page 11)  
test pin CNE702 : short

### Procedure:

1. Mode: record

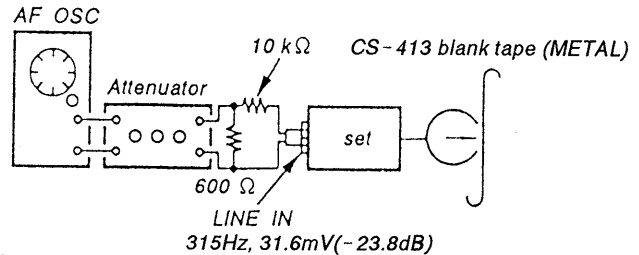

2. Mode: playback  
recorded portion

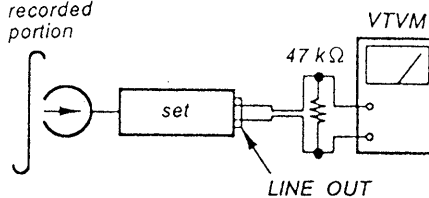

3. Playback the signal recorded in step 1.  
Adjust RV508 so that the R - channel meet the specification.

### Adjustment Limits:

1. 10KHz level difference against 315Hz reference.  
 $0\text{dB} \pm 0.3\text{dB}$

**Adjustment Location:** MAIN board

# Adjustment Location

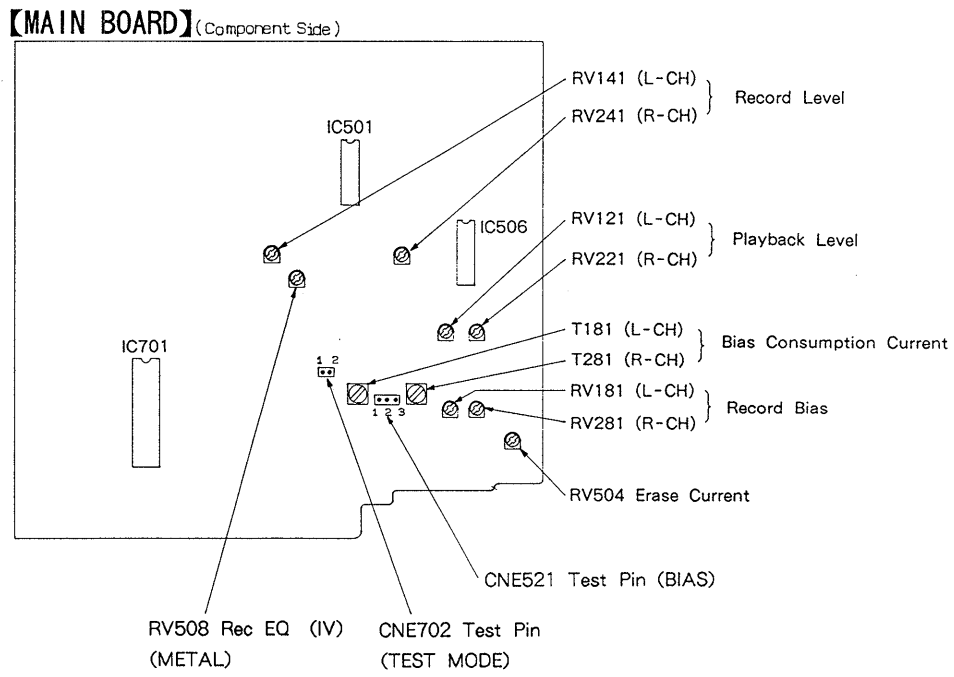

## SECTION 5 DIAGRAMS

### 5-1. CIRCUIT BOARDS LOCATION

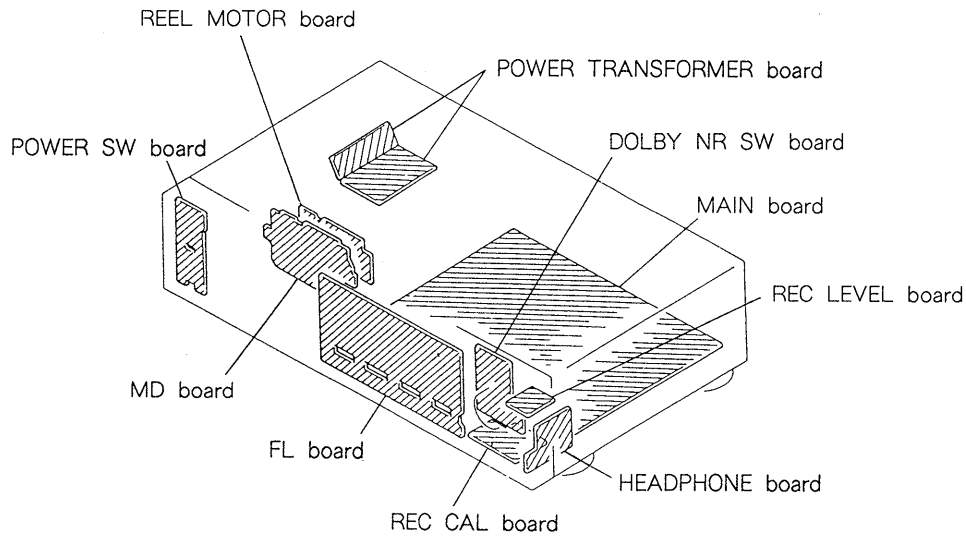

### 5-2. IC BLOCK DIAGRAM

- IC703 BA6219B
- IC704 LB1641

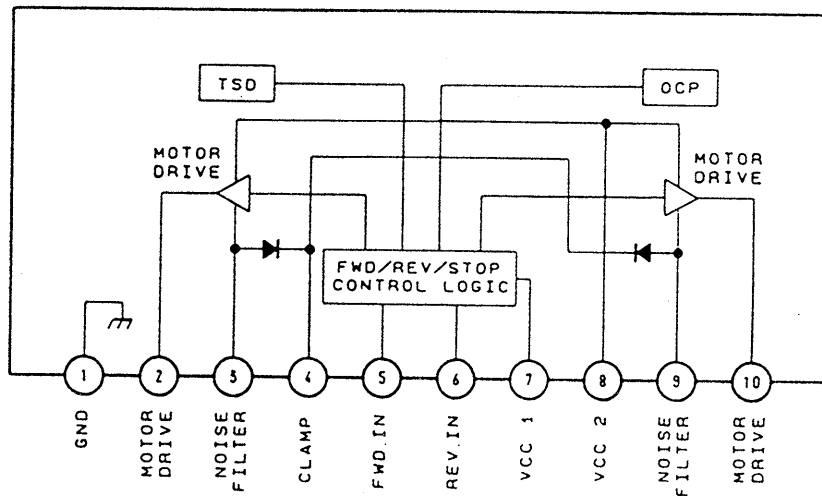



Semiconductor Location					
Ref. No.	Location	Ref. No.	Location	Ref. No.	Location
D101	D-3	D752	B-17	IC751	B-14
D102	E-3	D801	B-4	IC801	C-3
D201	E-3	D802	B-4	IC1001	C-23
D202	E-3	D803	B-4	IC1002	C-24
D501	G-3	D804	B-4		
D502	F-7	D805	C-3	Q101	I-3
D503	F-7	D806	D-3	Q102	G-6
D504	F-3	D807	B-5	Q103	I-7
D505	F-3	D812	B-5	Q201	H-3
D506	F-7	D813	B-5	Q202	H-6
D507	F-7	D814	C-5	Q203	J-7
D508	F-7	D815	B-5	Q501	F-3
D509	J-10	D816	B-3	Q502	F-3
D510	G-10	D817	B-3	Q503	G-3
D511	I-10	D818	C-5	Q504	I-4
D512	D-6	D819	D-5	Q505	D-6
D513	E-6	D820	B-5	Q506	J-10
D514	E-6	D822	B-5	Q507	J-9
D515	E-6	D823	B-4	Q508	G-10
D516	F-10	D1051	C-29	Q509	G-11
D701	E-8			Q510	G-11
D702	E-8	IC501	G-4	Q511	G-10
D703	B-7	IC502	I-4	Q512	G-9
D704	B-7	IC503	H-7	Q513	F-6
D705	A-7	IC504	H-9	Q514	F-6
D706	C-8	IC505	J-8	Q515	F-6
D707	C-8	IC506	J-6	Q516	F-6
D708	D-7	IC507	I-19	Q517	F-11
D709	D-7	IC508	D-6	Q701	E-8
D712	E-9	IC509	E-3	Q702	D-9
D713	E-10	IC510	G-3	Q703	D-8
D714	D-10	IC701	B-10	Q704	E-8
D715	D-10	IC702	E-9	Q705	B-6
D718	D-10	IC703	B-6	Q706	B-6
D751	B-17	IC704	A-6	Q707	C-9

**Note on Schematic Diagram :**

- All capacitors are in  $\mu\text{F}$  unless otherwise noted. pF:  $\mu\text{F}$  50WV or less are not indicated except for electrolytics and tantalums. ( ) : TC-K679ES
- All resistors are in  $\Omega$  and  $\text{W}$  or less unless otherwise specified. ( ) : TC-K679ES
- : fusible resistor.

**Note:** The components identified by mark  $\Delta$  or dotted line with mark  $\Delta$  are critical for safety. Replace only with part number specified.

**Note:** Les composants identifiés par une marque  $\Delta$  sont critiques pour la sécurité. Ne les remplacer que par une pièce portant le numéro spécifié.

- : B + Line
- : B - Line
- : adjustment for repair.
- Voltage and waveforms are dc with respect to ground under no-signal conditions. no mark : PB ( ) : REC
- Voltages are taken with a VOM (input impedance 10 M $\Omega$ ). Voltage variations may be noted due to normal production tolerances.
- Waveforms are taken with an oscilloscope. Voltage variations may be noted due to normal production tolerances.
- Signal path. : PB : REC

- Note on Mounting Diagram :**
- : Parts extracted from the component side.
  - : Parts mounted on the conductor side.

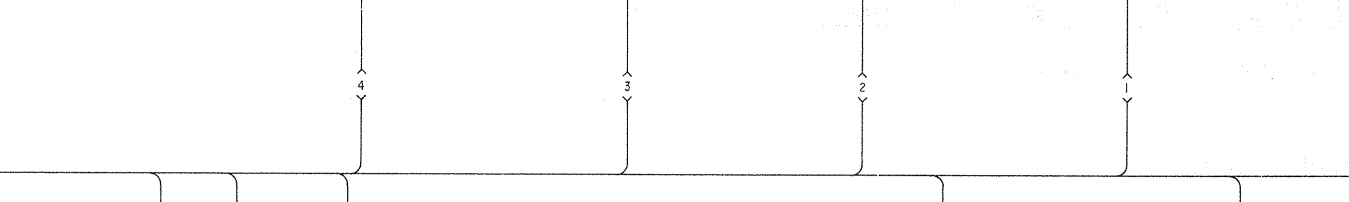
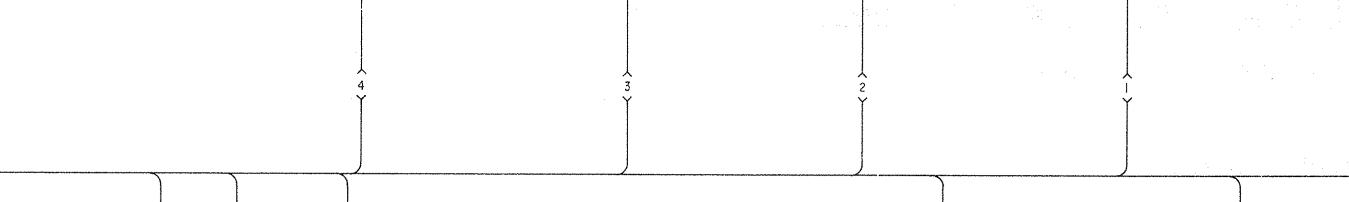
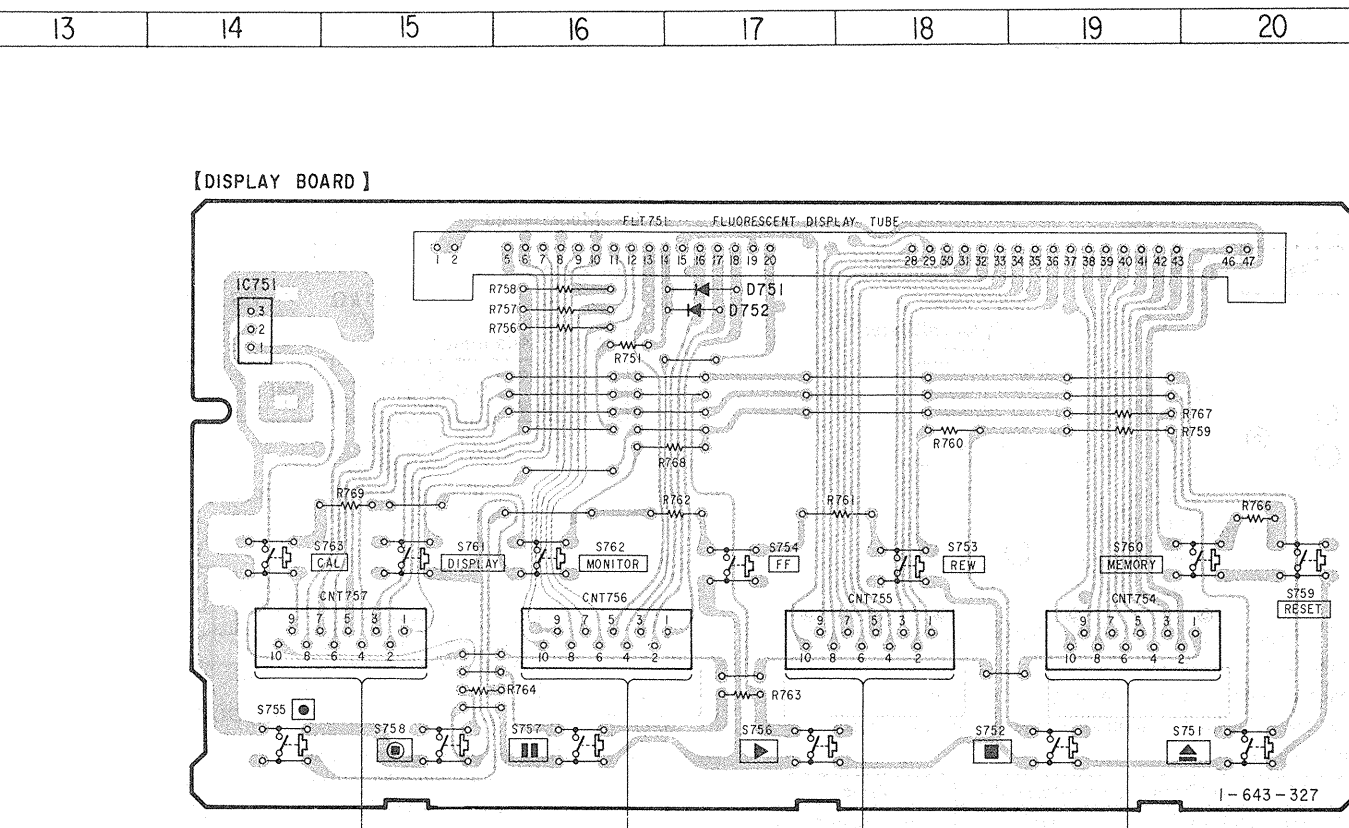
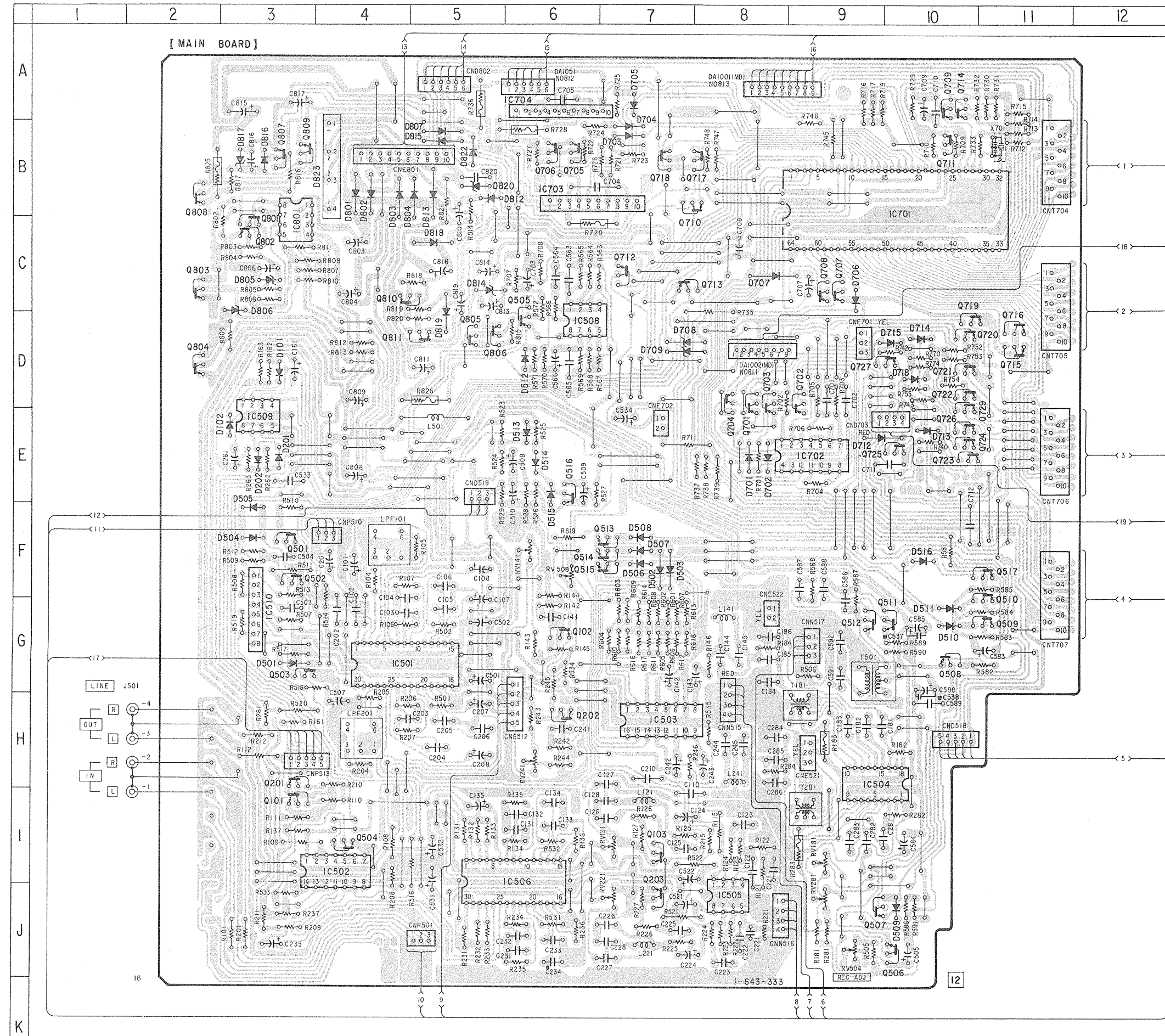



5-4. SCHEMATIC DIAGRAM •See page 15 for IC Block Diagram.

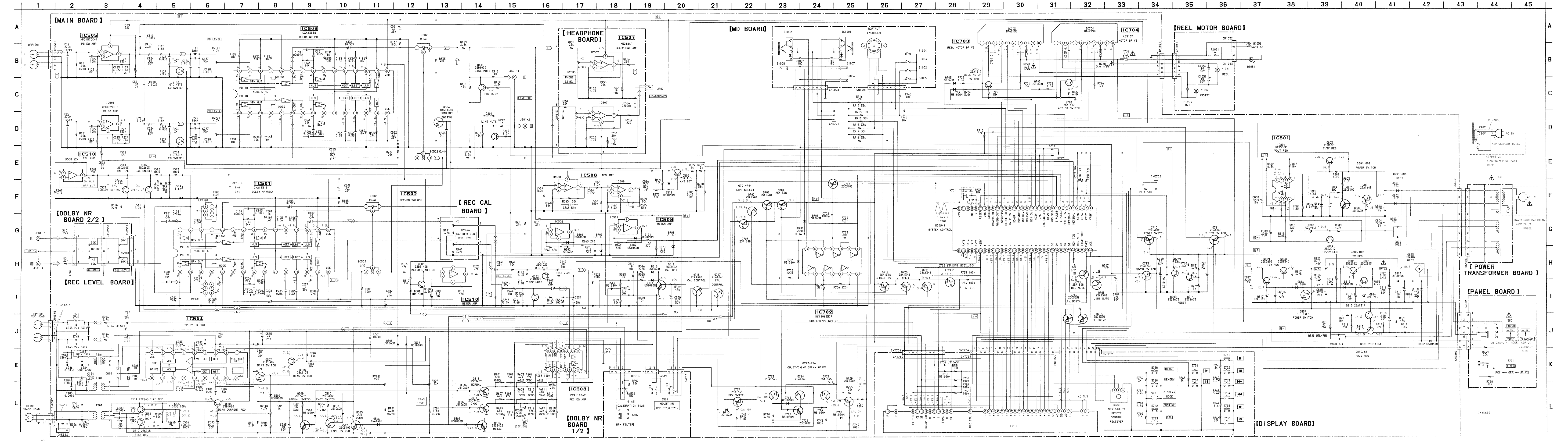



5-5. SEMICONDUCTOR LEAD LAYOUTS

BA6219B  
LB1641

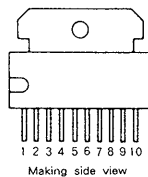

DTC144ES  
2SA1175-HFE

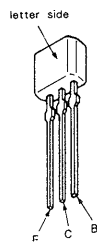

HZS6A1L  
HZS7A1L

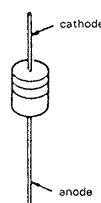

M5218AL

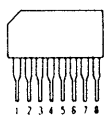

2SB1094-LK  
2SD2012

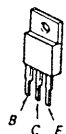

1N4148M  
10E2N  
21DQ05

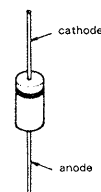

SBX1610-59

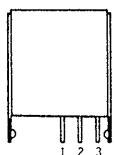

2SB1116A-L  
2SC945-P

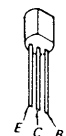

1 Vout  
2 Vcc  
3 GND

DTA114ES  
DTA144ES  
DTC114ES  
DTC143TS  
2SA1317-STU  
2SC2603-EF  
2SD2144S



GP2S22B

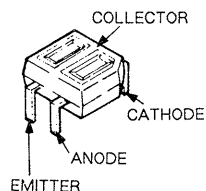

NOTE:

- XX, - X mean standardized parts, so they may have some differences from the original one.
- Color Indication of Appearance Parts  
Example :  
KNOB, BALANCE (WHITE)...(RED)  
Parts color      Cabinet's color

- Items marked "\*" are not stocked since they are seldom required for routine service. Some delay should be anticipated when ordering these items.
- The mechanical parts with no reference number in the exploded views are not supplied.
- Hardware (# mark) list is given in the last of this parts list.
- G : Germany model

The components identified by mark  $\Delta$  or dotted line with mark  $\Delta$  are critical for safety. Replace only with part number specified.

Les composants identifiés par une marque  $\Delta$  sont critiques pour la sécurité. Ne les remplacer que par une pièce portant le numéro spécifié.

6-1. CHASSIS SECTION

- $\blacktriangle$  B : POWER TRANSFORMER board
- $\blacksquare$  B-F : See next page

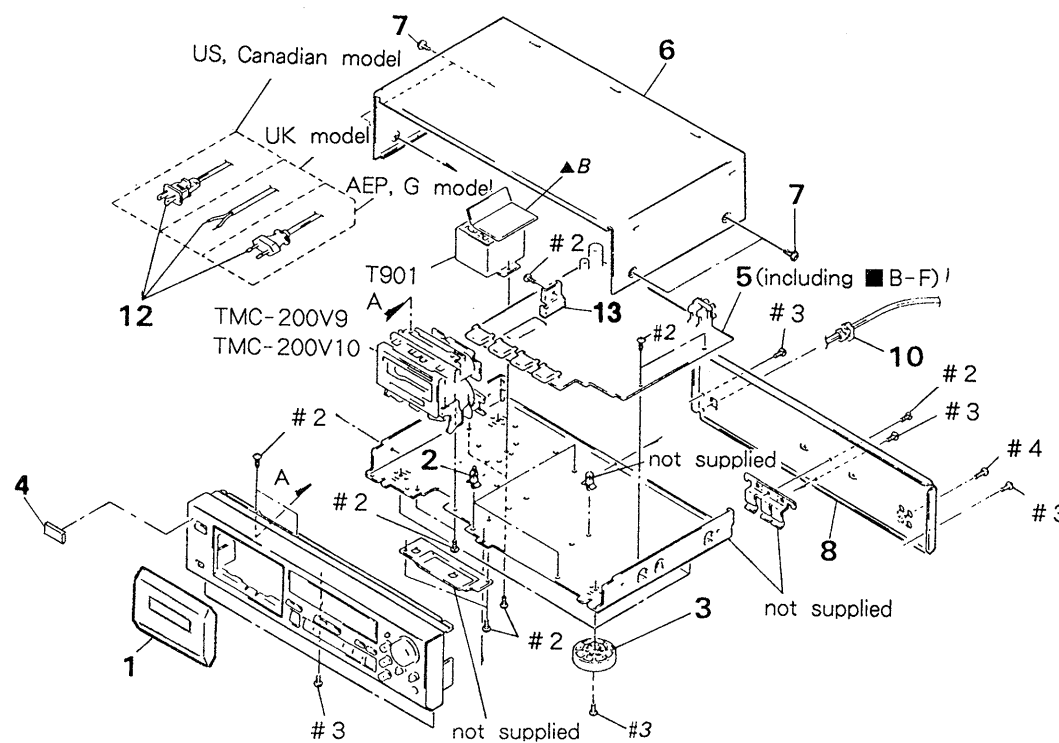

Ref. No.	Part No.	Description	Remarks	Ref. No.	Part No.	Description	Remarks
1	X-3363-220-1	LID (A) ASSY, CASSETTE (K690:US)		* 8	3-375-666-21	PANEL, BACK (K690:AEP)	
1	X-3365-066-1	LID ASSY, CASSETTE (K679ES)		* 10	3-703-244-00	BUSHING (2104), CORD (K679ES:UK	
1	X-3365-069-1	LID ASSY, CASSETTE (K690:AEP, Germany)				/K690:AEP, Germany)	
* 2	3-346-265-11	HOLDER, PC BOARD		* 10	3-703-571-11	BUSHING (S) (4516), CORD (K679ES:US,	
3	4-943-148-32	FOOT (F58175SW) (K690:US)				Canadian/K690:US)	
3	4-943-148-42	FOOT (K690:AEP, Germany, K679ES)		$\Delta$ 12	1-555-795-00	CORD, POWER, EULO PLUG (K690:AEP,	
4	4-908-848-01	EMBLEM, SONY				Germany)	
* 5	A-2006-759-A	MAIN BOARD, COMPLETE (K690)		$\Delta$ 12	1-556-035-00	CORD, POWER (K679ES:UK)	
* 5	A-2006-772-A	MAIN BOARD, COMPLETE (K679ES)		$\Delta$ 12	1-558-945-11	CORD, POWER (POLAR. SPT-1) (K679ES:US,	
6	3-332-578-61	CASE				Canadian/K690:US)	
7	3-704-366-01	SCREW (CASE) (M3X8)		* 13	3-356-925-01	HEAT SINK	
* 8	3-375-665-01	PANEL, BACK (K679ES:US, Canadian)		$\Delta$ T901	1-450-100-11	TRANSFORMER, POWER (K679ES:US, Canadian	
* 8	3-375-665-11	PANEL, BACK (K679ES:UK)				/K690:US)	
* 8	3-375-666-01	PANEL, BACK (K690:AEP, Germany)		$\Delta$ T901	1-450-399-11	TRANSFORMER, POWER (K679ES:UK	
* 8	3-375-666-11	PANEL, BACK (K690:US)				/K690:AEP, Germany)	

## 6-2. FRONT PANEL SECTION

- B : PANEL board
- C : DOLBY NR board
- D : REC LEVEL board
- E : HEADPHONE board
- F : REC CAL board

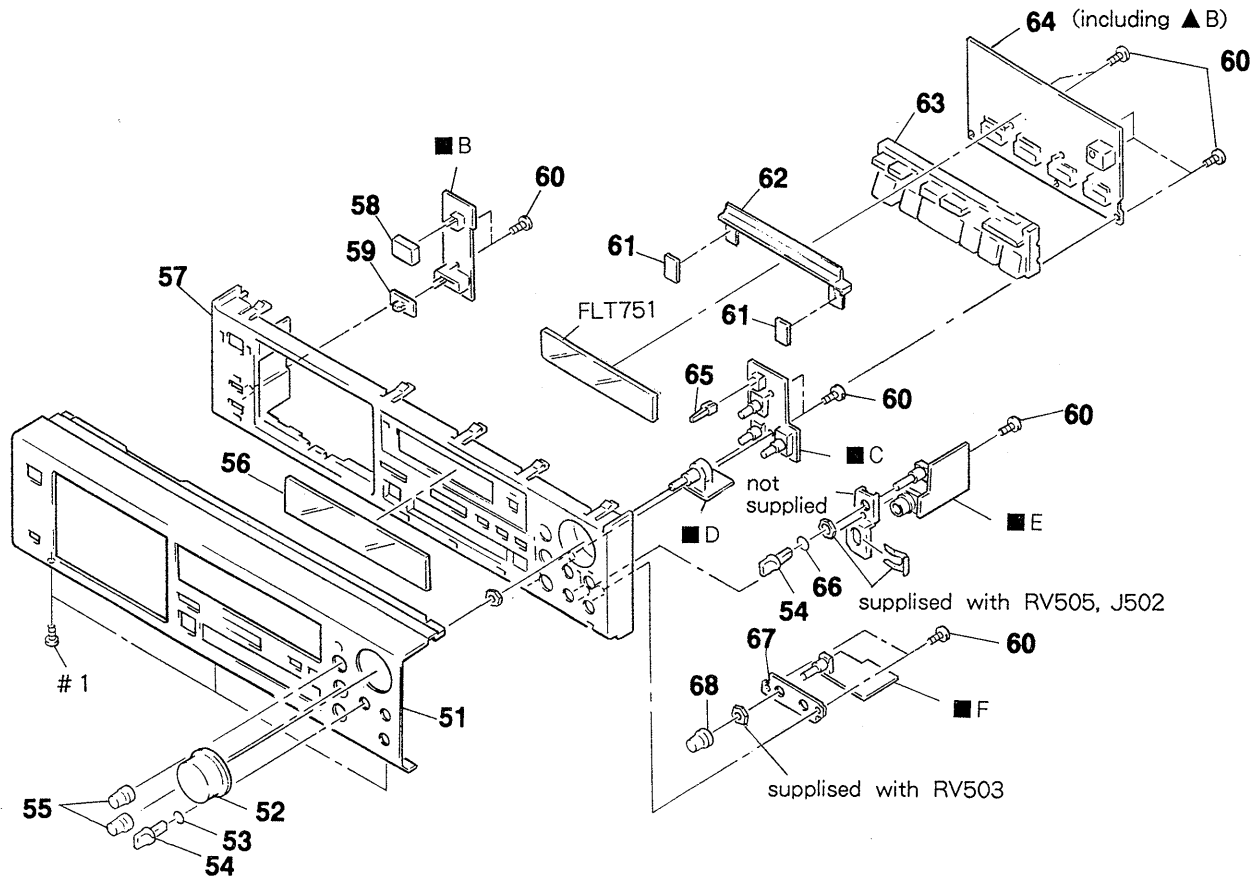

Ref. No.	Part No.	Description	Remarks
51	3-379-229-01	PANEL, FRONT (K690:AEP, Germany)	
51	3-379-229-11	PANEL, FRONT (K690:US)	
51	3-379-229-41	PANEL, FRONT (K679ES:US, Canadian)	
51	3-379-229-51	PANEL, FRONT (K679ES:UK)	
52	3-367-438-11	KNOB (REC)	
53	3-370-186-01	SPRING (SWPA), RING	
54	3-350-495-01	KNOB (VOL)	
55	3-367-431-01	KNOB (BAL)	
56	3-367-433-11	WINDOW (METER) (K690:US)	
56	3-378-144-11	WINDOW (METER) (K679ES/K690:AEP, Germany)	
57	3-367-440-01	PANEL (BASE)	
58	4-922-921-01	BUTTON (POWER)	

Ref. No.	Part No.	Description	Remarks
59	4-931-421-11	KNOB (T & S)	
60	4-928-635-01	SCREW, +BV (2. 6X8) TAPPING	
61	9-911-844-XX	CUSHION	
* 62	4-932-502-01	HOLDER, FL TUBE	
63	3-368-281-31	BUTTON (B)	
* 64	1-643-327-11	FL BOARD	
65	3-350-473-01	BUTTON (MPX)	
66	3-356-957-01	SPRING	
* 67	3-368-280-01	BRACKET (C)	
68	3-370-003-01	KNOB (BAL)	
FLT751	1-519-710-11	INDICATOR TUBE, FLUORESCENT	

6-3. MECHANISM SECTION 1 (TCM-200V9:TC-K679ES)  
(TCM-200V10:TC-K690)

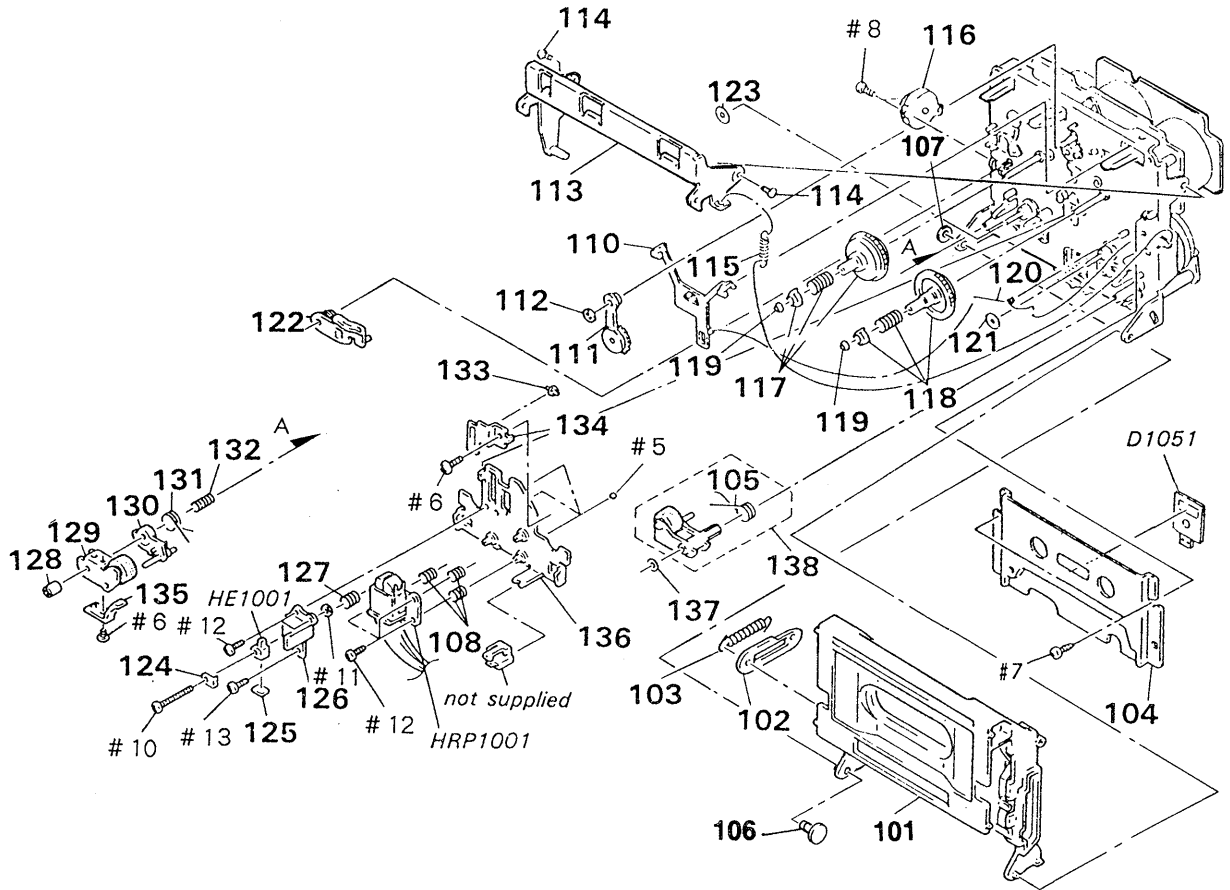

Ref. No.	Part No.	Description	Remarks	Ref. No.	Part No.	Description	Remarks
101	X-3364-799-1	HOLDER (CD) (2) ASSY, CASSETTE		122	X-3356-623-1	LEVER (BT) ASSY	
* 102	3-356-717-01	LEVER (JOINT)		123	3-356-713-01	WASHER	
103	3-356-626-01	SPRING, TENSION		124	3-318-433-01	SPRING	
104	X-3356-613-1	PLATE ASSY, ORNAMENTAL		* 125	1-608-268-00	PC BOARD, ERASE HEAD	
105	3-356-672-01	SPRING (PINCH LEVER T), TORSION		* 126	3-576-977-00	BRACKET, E. HEAD	
106	3-378-341-01	SHAFT (L) (CASSETTE HOLDER) (K690)		127	3-564-121-00	SPRING, COMPRESSION	
107	3-558-708-21	WASHER, STOPPER (K690)		128	3-356-652-01	NUT (PINCH LEVER S)	
108	3-356-659-01	SPRING (RPH), COMPRESSION		129	X-3356-621-1	LEVER (PINCH LEVER S) ASSY	
110	3-356-614-01	SLIDER (BRAKE)		130	3-356-660-01	LEVER (PS)	
111	X-3356-641-1	LEVER (FR2) ASSY		131	3-356-661-01	SPRING (PINCH LEVER S), TORSION	
112	3-669-465-11	WASHER (1.5), STOPPER		132	3-356-657-01	SPRING (PS), COMPRESSION	
* 113	X-3356-608-1	LEVER (LIFTER) ASSY		133	3-367-775-01	ROLLER (HEAD CHASSIS)	
114	3-356-601-11	SCREW, STEP		134	3-356-656-11	SPRING (HEAD PC BOARD), LEAF	
115	3-356-625-01	SPRING, TENSION		135	3-564-138-00	GUIDE (S), TAPE	
116	3-712-786-01	DAMPER, OIL		* 136	X-3362-861-1	SLIDER (HEAD CHASSIS V4) ASSY	
117	X-3356-629-1	GEAR (S) ASSY		137	3-669-596-00	WASHER (2.3), STOPPER	
118	X-3356-627-1	GEAR (T) ASSY		138	X-3356-620-1	LEVER (PINCH LEVER T) ASSY	
119	3-362-308-01	CAP (REEL)		D1051	8-719-980-85	DIODE SLF325C	
120	3-356-619-01	SPRING (B), TORSION		HE1001	1-543-836-11	HEAD, MAGNETIC (ERASE)	
121	3-332-763-01	RING, OIL RESERVOIR		HRP1001	1-543-834-11	HEAD, MAGNETIC (REC/PB) (K690)	
				HRP1001	1-543-835-11	HEAD, MAGNETIC (REC PB) (K679ES)	

**6-4. MECHANISM SECTION 2 (TCM-200V9:TC-K679ES)**  
**(TCM-200V10:TC-K690)**

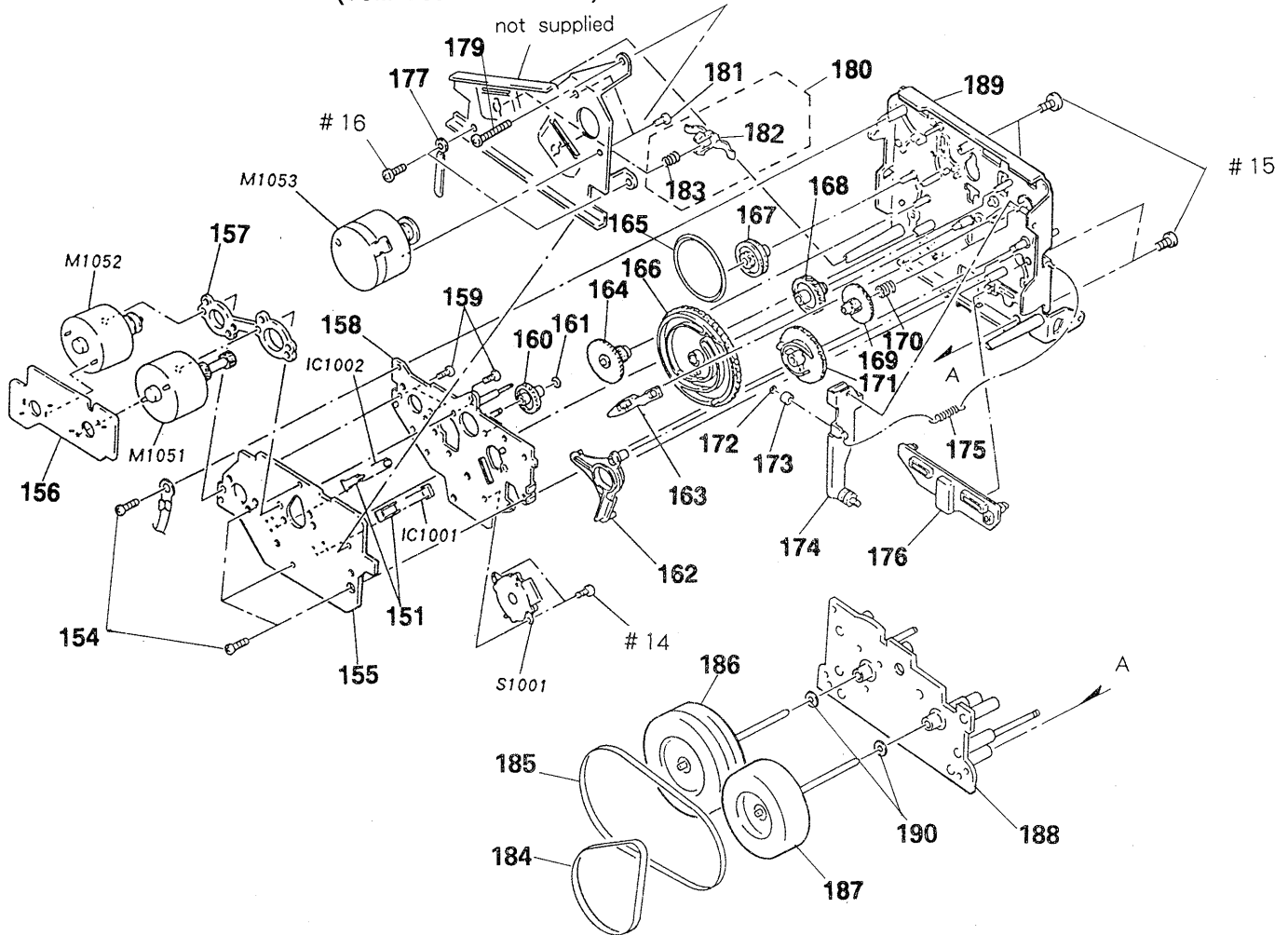

Ref. No.	Part No.	Description	Remarks	Ref. No.	Part No.	Description	Remarks
151	3-356-631-01	HOLDER (SENSOR)		175	3-376-854-01	SPRING, TENSION	
154	3-355-801-01	SCREW (BTP 2X18)		176	3-356-653-01	SLIDER (PAUSE)	
* 155	1-632-740-11	MD BOARD		177	3-703-150-11	STOPPER, WIRING	
* 156	1-632-741-11	REAL MOTOR BOARD		179	3-356-707-01	SCREW (+PTPWH 2X25)	
* 157	3-356-628-01	SPACER (MOTOR)		180	X-3365-071-1	RETAINER (V4) ASSY, THRUST	
* 158	X-3356-616-1	BRACKET (MOTOR D) ASSY		181	4-885-599-00	SCREW, FITTING, REINFORCEMENT	
159	3-363-804-01	SCREW (+P 2.6X6.5)		182	3-575-321-00	RETAINER, THRUST, CAPSTAN	
160	3-356-702-01	GEAR (COMMUNICATION B)		183	3-379-310-01	SPRING, COMPRESSION	
161	3-669-465-00	WASHER (1.5), STOPPER		184	3-367-774-01	BELT (CAPSTAN V4)	
162	3-356-613-01	LEVER (MODE)		185	3-364-600-01	BELT (CAPSTAN)	
163	3-356-617-01	LEVER (SELECTION)		186	X-3362-863-1	FLYWHEEL (VT) ASSY	
164	3-356-606-01	GEAR (MODE)		187	X-3362-864-1	FLYWHEEL (VS) ASSY	
165	3-356-603-01	BELT (MODE)		* 188	X-3362-865-1	BRACKET (CAPSTAN BASE) ASSY	
166	3-356-747-01	GEAR (MODE CAM C)		* 189	X-3362-862-1	CHASSIS (V4) ASSY, MECHANICAL	
167	3-356-607-01	PULLEY (MODE)		190	3-356-705-31	WASHER (CAPSTAN)	
168	3-356-703-01	GEAR (COMMUNICATION C)		M1051	X-3356-638-1	MOTOR (REEL R) ASSY	
169	3-356-609-01	GEAR (LOADING)		M1052	X-3356-604-1	MOTOR (ASSIST) ASSY	
170	3-356-605-01	SPRING, COMPRESSION		M1053	X-3356-635-1	MOTOR (CAPSTAN R2) ASSY	
171	3-356-616-01	GEAR (LOADING CAM)		S1001	1-466-238-11	ENCORDER, ROTARY	
172	3-558-708-11	WASHER, STOPPER		IC1001	8-749-920-97	DIODE GP2S22B	
173	3-356-630-01	ROLLER (LOADING)		IC1002	8-749-920-97	DIODE GP2S22B	
* 174	X-3356-606-1	LEVER (LOADING) ASSY					

FL MD

SECTION 7  
ELECTRICAL PARTS LIST

NOTE:

- Due to standardization, replacements in the parts list may be different from the parts specified in the diagrams or the components used on the set.
- -XX, -X mean standardized parts, so they may have some difference from the original one.
- Items marked "\*" are not stocked since they are seldom required for routine service. Some delay should be anticipated when ordering these items.
- CAPACITORS :  
uF :  $\mu$ F

- RESISTORS  
All resistors are in ohms.  
METAL : metal-film resistor  
METAL OXIDE : Metal Oxide-film resistor  
F : nonflammable
- COILS  
uH :  $\mu$ H
- SEMICONDUCTORS  
In each case, u :  $\mu$ , for example :  
uA... :  $\mu$ A..., uPA... ,  $\mu$ PA... ,  
uPB... ,  $\mu$ PB... , uPC... ,  $\mu$ PC... ,  
uPD... ,  $\mu$ PD...

The components identified by mark  $\Delta$  or dotted line with mark  $\Delta$  are critical for safety.  
Replace only with part number specified.

When indicating parts by reference number, please include the board name.

Ref. No.	Part No.	Description	Remarks
*	1-643-327-11	FL BOARD *****	
	9-911-844-XX	CUSHION	
*	4-932-502-01	HOLDER, FL TUBE  < CONNECTOR >	
* CNT704	1-580-782-11	CONNECTOR, BOARD TO BOARD	
* CNT705	1-580-782-11	CONNECTOR, BOARD TO BOARD	
* CNT706	1-580-782-11	CONNECTOR, BOARD TO BOARD	
* CNT707	1-580-782-11	CONNECTOR, BOARD TO BOARD  < CAPACITOR >	
C751	1-126-022-11	ELECT 47uF 20% 25V  < DIODE >	
D751	8-719-987-63	DIODE 1N4148M	
D752	8-719-987-63	DIODE 1N4148M  < FILTER >	
FLT751	1-519-710-11	INDICATOR TUBE, FLUORESCENT  < IC >	
IC751	8-741-100-48	IC SBX1610-59  < RESISTOR >	
R751	1-249-441-11	CARBON 100K 5% 1/4W	
R756	1-249-441-11	CARBON 100K 5% 1/4W	
R757	1-249-441-11	CARBON 100K 5% 1/4W	
R758	1-249-441-11	CARBON 100K 5% 1/4W	
R759	1-247-838-00	CARBON 2K 5% 1/4W	
R760	1-249-422-11	CARBON 2.7K 5% 1/4W	
R761	1-249-426-11	CARBON 5.6K 5% 1/4W	
R762	1-247-856-00	CARBON 11K 5% 1/4W	
R763	1-247-838-00	CARBON 2K 5% 1/4W	
R764	1-247-866-11	CARBON 30K 5% 1/4W	

Ref. No.	Part No.	Description	Remarks
R766	1-247-838-00	CARBON 2K 5% 1/4W	
R767	1-249-422-11	CARBON 2.7K 5% 1/4W	
R768	1-249-426-11	CARBON 5.6K 5% 1/4W	
R769	1-247-856-00	CARBON 11K 5% 1/4W  < SWITCH >	
S751	1-554-303-21	SWITCH, TACTILE ( $\blacktriangle$ )	
S752	1-554-303-21	SWITCH, TACTILE ( $\blacksquare$ )	
S753	1-554-303-21	SWITCH, TACTILE (REW)	
S754	1-554-303-21	SWITCH, TACTILE (FF)	
S755	1-554-303-21	SWITCH, TACTILE ( $\bullet$ )	
S756	1-554-303-21	SWITCH, TACTILE ( $\blacktriangleright$ )	
S757	1-554-303-21	SWITCH, TACTILE ( $\blacksquare$ )	
S758	1-554-303-21	SWITCH, TACTILE ( $\bullet$ )	
S759	1-554-303-21	SWITCH, TACTILE (RESET)	
S760	1-554-303-21	SWITCH, TACTILE (MEMORY)	
S761	1-554-303-21	SWITCH, TACTILE (DISPLAY)	
S762	1-554-303-21	SWITCH, TACTILE (MONITOR)	
S763	1-554-303-21	SWITCH, TACTILE (CAL)	
*****			
*	1-632-740-11	MD BOARD *****  3-356-631-01 HOLDER (SENSOR)	
		< CONNECTOR >	
CN1001	1-506-615-11	PIN, CONNECTOR 9P	
CN1002	1-564-501-11	PIN, CONNECTOR 8P  < IC >	
IC1001	8-749-920-97	DIODE GP2S22B	
IC1002	8-749-920-97	DIODE GP2S22B	

**MD MAIN**

Ref. No.	Part No.	Description	Remarks
< RESISTOR >			
R1001	1-249-408-11	CARBON 180 5% 1/4W	
R1002	1-249-408-11	CARBON 180 5% 1/4W	
< SWITCH >			
S1002	1-570-953-11	SWITCH, PUSH (1 KEY) (DOOR)	
S1003	1-571-958-11	SWITCH, PUSH (1 KEY) (CLOSE)	
S1004	1-572-126-11	SWITCH, PUSH (1 KEY) (OPEN)	
S1005	1-572-125-11	SWITCH, LEAF (FWD)	
S1006	1-572-202-11	SWITCH, LEAF (HALF)	
S1007	1-572-125-11	SWITCH, LEAF (METAL)	
S1008	1-572-125-11	SWITCH, LEAF (70uS)	
< TERMINAL >			
* TB1001	1-694-018-11	TERMINAL (5P)	
*****			
*	A-2006-772-A	MAIN BOARD, COMPLETE (K679ES)	
*****			
*	A-2006-759-A	MAIN BOARD, COMPLETE (K690)	
*****			
*	1-562-327-00	SOCKET, CONNECTOR 3P	
*	1-690-880-31	READ (WITH CONNECTOR)	
*	3-356-925-01	HEAT SINK	
	7-682-547-04	SCREW +BVTT 3X6 (S)	
< CAPACITOR >			
C101	1-126-059-11	ELECT 10uF 20% 50V	
C102	1-162-286-31	CERAMIC 220PF 10% 50V	
C103	1-130-475-00	MYLAR 0.0022uF 5% 50V	
C104	1-130-475-00	MYLAR 0.0022uF 5% 50V	
C105	1-136-174-00	FILM 0.56uF 5% 50V	
C106	1-136-171-00	FILM 0.33uF 5% 50V	
C107	1-126-059-11	ELECT 10uF 20% 50V	
C108	1-124-657-00	ELECT 10uF 20% 50V	
C110	1-161-494-00	CERAMIC 0.022uF 25V	
C121	1-110-335-11	MYLAR 100PF 5% 50V	(K679ES)
C121	1-110-340-11	MYLAR 270PF 5% 50V	(K690)
C122	1-162-282-31	CERAMIC 100PF 10% 50V	
C123	1-130-487-00	MYLAR 0.022uF 5% 50V	
C124	1-124-657-00	ELECT 10uF 20% 50V	
C125	1-130-488-00	MYLAR 0.027uF 5% 50V	
C126	1-130-474-00	MYLAR 0.0018uF 5% 50V	
C127	1-102-518-11	CERAMIC 33PF 5% 50V	
C128	1-130-474-00	MYLAR 0.0018uF 5% 50V	
C131	1-130-475-00	MYLAR 0.0022uF 5% 50V	

Ref. No.	Part No.	Description	Remarks
C132	1-130-475-00	MYLAR 0.0022uF 5% 50V	
C133	1-136-174-00	FILM 0.56uF 5% 50V	
C134	1-136-171-00	FILM 0.33uF 5% 50V	
C135	1-124-657-00	ELECT 10uF 20% 50V	
C141	1-136-175-00	FILM 0.68uF 5% 50V	
C142	1-126-059-11	ELECT 10uF 20% 50V	
C143	1-126-059-11	ELECT 10uF 20% 50V	
C144	1-110-338-51	MYLAR 180PF 5% 50V	
C145	1-136-935-11	FILM 22PF 5% 630V	
C161	1-124-925-11	ELECT 2.2uF 20% 100V	
C181	1-136-153-00	FILM 0.01uF 5% 50V	
C182	1-136-157-00	FILM 0.022uF 5% 50V	
C183	1-136-161-00	FILM 0.047uF 5% 50V	
C184	1-136-803-11	FILM 560PF 5% 630V	
C185	1-136-433-11	FILM 100PF 5% 630V	
C186	1-130-468-00	MYLAR 560PF 5% 50V	
C201	1-126-059-11	ELECT 10uF 20% 50V	
C202	1-162-286-31	CERAMIC 220PF 10% 50V	
C203	1-130-475-00	MYLAR 0.0022uF 5% 50V	
C204	1-130-475-00	MYLAR 0.0022uF 5% 50V	
C205	1-136-174-00	FILM 0.56uF 5% 50V	
C206	1-136-171-00	FILM 0.33uF 5% 50V	
C207	1-126-059-11	ELECT 10uF 20% 50V	
C208	1-124-657-00	ELECT 10uF 20% 50V	
C210	1-161-494-00	CERAMIC 0.022uF 25V	
C221	1-110-335-11	MYLAR 100PF 5% 50V	(K679ES)
C221	1-110-340-11	MYLAR 270PF 5% 50V	(K690)
C222	1-162-282-31	CERAMIC 100PF 10% 50V	
C223	1-130-487-00	MYLAR 0.022uF 5% 50V	
C224	1-124-657-00	ELECT 10uF 20% 50V	
C225	1-130-488-00	MYLAR 0.027uF 5% 50V	
C226	1-130-474-00	MYLAR 0.0018uF 5% 50V	
C227	1-102-518-11	CERAMIC 33PF 5% 50V	
C228	1-130-474-00	MYLAR 0.0018uF 5% 50V	
C231	1-130-475-00	MYLAR 0.0022uF 5% 50V	
C232	1-130-475-00	MYLAR 0.0022uF 5% 50V	
C233	1-136-174-00	FILM 0.56uF 5% 50V	
C234	1-136-171-00	FILM 0.33uF 5% 50V	
C235	1-124-657-00	ELECT 10uF 20% 50V	
C241	1-136-175-00	FILM 0.68uF 5% 50V	
C242	1-126-059-11	ELECT 10uF 20% 50V	
C243	1-126-059-11	ELECT 10uF 20% 50V	
C244	1-110-338-51	MYLAR 180PF 5% 50V	
C245	1-136-935-11	FILM 22PF 5% 630V	
C261	1-124-925-11	ELECT 2.2uF 20% 100V	
C281	1-136-153-00	FILM 0.01uF 5% 50V	
C282	1-136-157-00	FILM 0.022uF 5% 50V	

MAIN

Ref. No.	Part No.	Description	Remarks	Ref. No.	Part No.	Description	Remarks
C283	1-136-161-00	FILM	0.047uF 5% 50V	C803	1-124-556-11	ELECT	2200uF 20% 16V
C284	1-136-803-11	FILM	560PF 5% 630V	C804	1-124-556-11	ELECT	2200uF 20% 16V
C285	1-136-433-11	FILM	100PF 5% 630V	C806	1-124-477-11	ELECT	47uF 20% 25V
C286	1-130-468-00	MYLAR	560PF 5% 50V	C808	1-124-999-11	ELECT	2200uF 20% 10V
C501	1-126-022-11	ELECT	47uF 20% 25V	C809	1-124-999-11	ELECT	2200uF 20% 10V
C502	1-126-022-11	ELECT	47uF 20% 25V	C810	1-124-907-11	ELECT	10uF 20% 50V
C503	1-130-478-00	MYLAR	0.0039uF 5% 50V	C811	1-126-936-11	ELECT	3300uF 20% 16V
C504	1-136-164-00	FILM	0.082uF 5% 50V	C813	1-124-907-11	ELECT	10uF 20% 50V
C505	1-124-902-00	ELECT	0.47uF 20% 50V	C814	1-126-916-11	ELECT	1000uF 20% 6.3V
C506	1-161-494-00	CERAMIC	0.022uF 25V	C815	1-124-564-11	ELECT	4700uF 20% 25V
C507	1-124-925-11	ELECT	2.2uF 20% 100V	C816	1-124-907-11	ELECT	10uF 20% 50V
C508	1-124-925-11	ELECT	2.2uF 20% 100V	C817	1-126-768-11	ELECT	2200uF 20% 16V
C509	1-124-925-11	ELECT	2.2uF 20% 100V	C818	1-124-122-11	ELECT	100uF 20% 50V
C510	1-124-907-11	ELECT	10uF 20% 50V	C819	1-126-947-11	ELECT	47uF 20% 35V
C521	1-124-994-11	ELECT	100uF 20% 10V	C820	1-164-159-11	CERAMIC	0.1uF 50V
C522	1-124-994-11	ELECT	100uF 20% 10V	< CONNECTOR >			
C531	1-126-022-11	ELECT	47uF 20% 25V	* CND518	1-564-339-00	PIN, CONNECTOR	5P
C532	1-126-022-11	ELECT	47uF 20% 25V	* CND519	1-564-337-61	PIN, CONNECTOR	3P
C533	1-164-159-11	CERAMIC	0.1uF 50V	* CND703	1-564-338-71	PIN, CONNECTOR	4P
C534	1-124-903-11	ELECT	1uF 20% 50V	* CND802	1-564-340-00	PIN, CONNECTOR	6P
C535	1-124-907-11	ELECT	10uF 20% 50V	* CNE512	1-564-508-11	PLUG, CONNECTOR	5P
C536	1-124-907-11	ELECT	10uF 20% 50V	* CNE521	1-564-506-11	PLUG, CONNECTOR	3P
C537	1-136-174-00	ELECT	0.56uF 5% 50V	* CNE522	1-564-505-11	PLUG, CONNECTOR	2P
C538	1-136-174-00	ELECT	0.56uF 5% 50V	* CNE701	1-564-506-11	PLUG, CONNECTOR	3P
C563	1-162-217-31	CERAMIC	56PF 5% 50V	* CNE702	1-564-505-11	PLUG, CONNECTOR	2P
C564	1-136-157-00	FILM	0.022uF 5% 50V	* CNE801	1-564-513-11	PLUG, CONNECTOR	10P
C565	1-162-217-31	CERAMIC	56PF 5% 50V	* CNN515	1-560-062-00	PIN, CONNECTOR	4P
C566	1-124-925-11	ELECT	2.2uF 20% 100V	* CNN516	1-560-062-00	PIN, CONNECTOR	4P
C583	1-124-907-11	ELECT	10uF 20% 50V	* CNN517	1-560-061-00	PIN, CONNECTOR	3P
C584	1-124-477-11	ELECT	47uF 20% 25V	* CNP501	1-564-705-11	PIN, CONNECTOR (SMALL TYPE)	3P
C585	1-124-477-11	ELECT	47uF 20% 25V	* CNP508	1-564-705-11	PIN, CONNECTOR (SMALL TYPE)	3P
C586	1-136-593-11	FILM	0.0033uF 5% 100V	* CNP509	1-564-719-11	PIN, CONNECTOR (SMALL TYPE)	3P
C587	1-136-593-11	FILM	0.0033uF 5% 100V	* CNP510	1-564-705-11	PIN, CONNECTOR (SMALL TYPE)	3P
C588	1-130-955-00	FILM	0.01uF 5% 100V	* CNP513	1-564-707-11	PIN, CONNECTOR (SMALL TYPE)	5P
C589	1-161-494-00	CERAMIC	0.022uF 25V	* CNP514	1-564-707-11	PIN, CONNECTOR (SMALL TYPE)	5P
C590	1-124-907-11	ELECT	10uF 20% 50V	* CNT704	1-580-784-11	CONNECTOR, BOARD TO BOARD	
C591	1-107-045-00	MICA	3.9PF 500V	* CNT705	1-580-784-11	CONNECTOR, BOARD TO BOARD	
C592	1-136-559-11	FILM	0.0047uF 5% 630V	* CNT706	1-580-784-11	CONNECTOR, BOARD TO BOARD	
C701	1-162-294-31	CERAMIC	0.001uF 10% 50V	* CNT707	1-580-784-11	CONNECTOR, BOARD TO BOARD	
C702	1-162-294-31	CERAMIC	0.001uF 10% 50V	< DIODE >			
C703	1-124-902-00	ELECT	0.47uF 20% 50V	D101	8-719-987-63	DIODE	1N4148M
C704	1-164-159-11	CERAMIC	0.1uF 50V	D102	8-719-987-63	DIODE	1N4148M
C705	1-164-159-11	CERAMIC	0.1uF 50V	D201	8-719-987-63	DIODE	1N4148M
C707	1-126-923-11	ELECT	220uF 20% 10V	D202	8-719-987-63	DIODE	1N4148M
C708	1-124-477-11	ELECT	47uF 20% 25V	D501	8-719-987-63	DIODE	1N4148M
C709	1-124-907-11	ELECT	10uF 20% 50V	D502	8-719-987-63	DIODE	1N4148M
C710	1-164-159-11	CERAMIC	0.1uF 50V	D503	8-719-987-63	DIODE	1N4148M
C711	1-164-159-11	CERAMIC	0.1uF 50V				
C712	1-164-159-11	CERAMIC	0.1uF 50V				

## MAIN

<u>Ref. No.</u>	<u>Part No.</u>	<u>Description</u>	<u>Remarks</u>	<u>Ref. No.</u>	<u>Part No.</u>	<u>Description</u>	<u>Remarks</u>
D504	8-719-987-63	DIODE	1N4148M	IC503	8-752-060-64	IC	CXA1198AP
D505	8-719-987-63	DIODE	1N4148M	IC504	8-759-106-56	IC	uPC1297CA
D506	8-719-987-63	DIODE	1N4148M	IC505	8-759-111-44	IC	uPC4570C-1
D507	8-719-987-63	DIODE	1N4148M	IC506	8-752-059-55	IC	CXA1331S
D508	8-719-987-63	DIODE	1N4148M	IC507	8-759-634-51	IC	M5218AP
D509	8-719-987-63	DIODE	1N4148M	IC508	8-759-945-58	IC	RC4558P
D510	8-719-987-63	DIODE	1N4148M	IC509	8-759-945-58	IC	RC4558P
D511	8-719-987-63	DIODE	1N4148M	IC510	8-759-634-50	IC	M5218AL
D512	8-719-987-63	DIODE	1N4148M	IC701	8-759-060-83	IC	M50941-712SP
D513	8-719-987-63	DIODE	1N4148M	IC702	8-759-240-69	IC	TC4069UBP
D514	8-719-987-63	DIODE	1N4148M	IC703	8-759-973-95	IC	BA6219B
D515	8-719-987-63	DIODE	1N4148M	IC704	8-759-822-09	IC	LB1641
D516	8-719-987-63	DIODE	1N4148M	IC801	8-759-945-58	IC	RC4558P
D701	8-719-987-63	DIODE	1N4148M				< JACK >
D702	8-719-987-63	DIODE	1N4148M	J501	1-573-070-11	JACK, PIN 4P (LINE)	(K679ES)
D703	8-719-987-63	DIODE	1N4148M	J501	1-565-258-11	JACK, PIN 4P (LINE)	(K690)
D704	8-719-987-63	DIODE	1N4148M	J502	1-507-796-71	JACK (HEADPHONES)	
D705	8-719-987-63	DIODE	1N4148M				< COIL >
D706	8-719-987-63	DIODE	1N4148M	L121	1-410-778-11	INDUCTOR	18mH
D707	8-719-200-77	DIODE	10E2N	L141	1-410-780-11	INDUCTOR	27mH
D708	8-719-933-33	DIODE	HZS6A1L	L221	1-410-778-11	INDUCTOR	18mH
D709	8-719-933-33	DIODE	HZS6A1L	L241	1-410-780-11	INDUCTOR	27mH
D712	8-719-987-63	DIODE	1N4148M	L501	1-408-080-00	INDUCTOR	100uH
D713	8-719-987-63	DIODE	1N4148M				< FILTER >
D714	8-719-987-63	DIODE	1N4148M	LPF101	1-236-147-11	FILTER, LOW PASS	
D715	8-719-987-63	DIODE	1N4148M	LPF201	1-236-147-11	FILTER, LOW PASS	
D718	8-719-987-63	DIODE	1N4148M				< TRANSISTOR >
D801	8-719-200-77	DIODE	10E2N	Q101	8-729-142-25	TRANSISTOR	2SD1020-HFE
D802	8-719-200-77	DIODE	10E2N	Q102	8-729-142-25	TRANSISTOR	2SD1020-HFE
D803	8-719-200-77	DIODE	10E2N	Q103	8-729-900-74	TRANSISTOR	DTC143TS
D804	8-719-200-77	DIODE	10E2N	Q201	8-729-142-25	TRANSISTOR	2SD1020-HFE
D805	8-719-933-33	DIODE	HZS6A1L	Q202	8-729-142-25	TRANSISTOR	2SD1020-HFE
D806	8-719-933-33	DIODE	HZS6A1L	Q203	8-729-900-74	TRANSISTOR	DTC143TS
D807	8-719-987-63	DIODE	1N4148M	Q501	8-729-620-05	TRANSISTOR	2SC2603-EF
D812	8-719-987-63	DIODE	1N4148M	Q502	8-729-620-05	TRANSISTOR	2SC2603-EF
D813	8-719-200-31	DIODE	21DQ05	Q503	8-729-922-37	TRANSISTOR	2SD2144S
D814	8-719-000-78	DIODE	HZS7A1L	Q504	8-729-900-80	TRANSISTOR	DTC114ES
D815	8-719-987-63	DIODE	1N4148M	Q505	8-729-119-76	TRANSISTOR	2SA1175-HFE
D816	8-719-987-63	DIODE	1N4148M	Q506	8-729-142-25	TRANSISTOR	2SD1020-HFE
D817	8-719-001-70	DIODE	UZL-12M1	Q507	8-729-900-80	TRANSISTOR	DTC114ES
D818	8-719-200-77	DIODE	10E2N	Q508	8-729-821-04	TRANSISTOR	2SA1317-STU
D819	8-719-200-77	DIODE	10E2N	Q509	8-729-900-80	TRANSISTOR	DTC114ES
D820	8-719-000-93	DIODE	UZL-7H1	Q510	8-729-900-80	TRANSISTOR	DTC114ES
D822	8-719-987-63	DIODE	1N4148M	Q511	8-729-194-57	TRANSISTOR	2SC945-P
D823	8-719-312-09	DIODE	RBA-402	Q512	8-729-194-57	TRANSISTOR	2SC945-P
			< IC >				
IC501	8-752-059-55	IC	CXA1331S				
IC502	8-759-000-49	IC	TC4069UBP				



MAIN

Ref. No.	Part No.	Description	Remarks	Ref. No.	Part No.	Description	Remarks
Q513	8-729-900-80	TRANSISTOR	DTC114ES	R106	1-259-461-11	CARBON	24K 5% 1/6W
Q514	8-729-900-80	TRANSISTOR	DTC114ES	R107	1-259-422-11	CARBON	560 5% 1/6W
Q515	8-729-900-80	TRANSISTOR	DTC114ES	R108	1-259-476-11	CARBON	100K 5% 1/6W
Q516	8-729-900-80	TRANSISTOR	DTC114ES	R109	1-259-436-11	CARBON	2. 2K 5% 1/6W
Q517	8-729-900-80	TRANSISTOR	DTC114ES	R110	1-249-421-11	CARBON	2. 2K 5% 1/4W
Q701	8-729-900-61	TRANSISTOR	DTA114ES	R111	1-259-467-11	CARBON	43K 5% 1/6W
Q702	8-729-900-61	TRANSISTOR	DTA114ES	R112	1-259-428-11	CARBON	1K 5% 1/6W
Q703	8-729-900-61	TRANSISTOR	DTA114ES	R115	1-249-421-11	CARBON	2. 2K 5% 1/4W
Q704	8-729-900-61	TRANSISTOR	DTA114ES	R121	1-259-466-11	CARBON	39K 5% 1/6W (K679ES)
Q705	8-729-119-76	TRANSISTOR	2SA1175-HFE	R121	1-259-476-11	CARBON	100K 5% 1/6W (K690)
Q706	8-729-119-76	TRANSISTOR	2SA1175-HFE	R122	1-259-402-11	CARBON	82 5% 1/6W
Q707	8-729-900-61	TRANSISTOR	DTA114ES	R123	1-259-479-11	CARBON	130K 5% 1/6W
Q708	8-729-900-61	TRANSISTOR	DTA114ES	R124	1-259-446-11	CARBON	5. 6K 5% 1/6W
Q709	8-729-620-05	TRANSISTOR	2SC2603-EF	R125	1-259-434-11	CARBON	1. 8K 5% 1/6W
Q710	8-729-900-80	TRANSISTOR	DTC114ES	R126	1-259-435-11	CARBON	2K 5% 1/6W
Q711	8-729-900-65	TRANSISTOR	DTA144ES	R127	1-259-484-11	CARBON	220K 5% 1/6W
Q712	8-729-900-80	TRANSISTOR	DTC114ES	R131	1-249-429-11	CARBON	10K 5% 1/4W
Q713	8-729-900-65	TRANSISTOR	DTA144ES	R132	1-249-429-11	CARBON	10K 5% 1/4W
Q714	8-729-620-05	TRANSISTOR	2SC2603-EF	R133	1-249-429-11	CARBON	10K 5% 1/4W
Q715	8-729-900-89	TRANSISTOR	DTC144ES	R134	1-259-461-11	CARBON	24K 5% 1/6W
Q716	8-729-900-89	TRANSISTOR	DTC144ES	R135	1-259-422-11	CARBON	560 5% 1/6W
Q717	8-729-900-61	TRANSISTOR	DTA114ES	R136	1-259-452-11	CARBON	10K 5% 1/6W
Q718	8-729-900-61	TRANSISTOR	DTA114ES	R137	1-259-476-11	CARBON	100K 5% 1/6W
Q719	8-729-900-61	TRANSISTOR	DTA114ES	R141	1-259-444-11	CARBON	4. 7K 5% 1/6W
Q720	8-729-900-61	TRANSISTOR	DTA114ES	R142	1-259-442-11	CARBON	3. 9K 5% 1/6W
Q721	8-729-900-61	TRANSISTOR	DTA114ES	R143	1-259-440-11	CARBON	3. 3K 5% 1/6W
Q722	8-729-900-61	TRANSISTOR	DTA114ES	R144	1-259-452-11	CARBON	10K 5% 1/6W
Q723	8-729-900-65	TRANSISTOR	DTA144ES	R145	1-249-421-11	CARBON	2. 2K 5% 1/4W
Q724	8-729-900-65	TRANSISTOR	DTA144ES	R146	1-259-444-11	CARBON	4. 7K 5% 1/6W
Q725	8-729-900-80	TRANSISTOR	DTC114ES	R151	1-249-433-11	CARBON	22K 5% 1/4W
Q726	8-729-900-65	TRANSISTOR	DTA144ES	R152	1-249-421-11	CARBON	2. 2K 5% 1/4W
Q727	8-729-900-65	TRANSISTOR	DTA144ES	R153	1-247-862-11	CARBON	20K 5% 1/4W
Q729	8-729-900-61	TRANSISTOR	DTA114ES	R154	1-249-409-11	CARBON	220 5% 1/4W
Q801	8-729-900-61	TRANSISTOR	DTA114ES	R161	1-249-434-11	CARBON	27K 5% 1/4W
Q802	8-729-900-80	TRANSISTOR	DTC114ES	R162	1-247-874-11	CARBON	62K 5% 1/4W
Q803	8-729-141-83	TRANSISTOR	2SB1094-LK	R163	1-249-410-11	CARBON	270 5% 1/4W
Q804	8-729-209-15	TRANSISTOR	2SD2012	R181	1-249-428-11	CARBON	8. 2K 5% 1/4W (K679ES)
Q805	8-729-209-15	TRANSISTOR	2SD2012	R181	1-249-427-11	CARBON	6. 8K 5% 1/4W (K690)
Q806	8-729-620-05	TRANSISTOR	2SC2603-EF	R182	1-249-435-11	CARBON	33K 5% 1/4W
Q807	8-729-900-80	TRANSISTOR	DTC114ES	△R183	1-219-153-11	FUSIBLE	10 5% 1/4W F
Q808	8-729-141-83	TRANSISTOR	2SB1094-LK	R184	1-247-883-00	CARBON	150K 5% 1/4W
Q809	8-729-620-05	TRANSISTOR	2SC2603-EF	R201	1-259-460-11	CARBON	22K 5% 1/6W
Q810	8-729-119-76	TRANSISTOR	2SA1175-HFE	R204	1-259-440-11	CARBON	3. 3K 5% 1/6W
Q811	8-729-140-04	TRANSISTOR	2SB1116A-L	R205	1-259-450-11	CARBON	8. 2K 5% 1/6W
		< RESISTOR >		R206	1-259-461-11	CARBON	24K 5% 1/6W
R101	1-259-460-11	CARBON	22K 5% 1/6W	R207	1-259-422-11	CARBON	560 5% 1/6W
R104	1-259-440-11	CARBON	3. 3K 5% 1/6W	R208	1-259-476-11	CARBON	100K 5% 1/6W
R105	1-259-450-11	CARBON	8. 2K 5% 1/6W	R209	1-259-436-11	CARBON	2. 2K 5% 1/6W
				R210	1-249-421-11	CARBON	2. 2K 5% 1/4W
				R211	1-259-467-11	CARBON	43K 5% 1/6W

**Note:**  
The components identified by mark  $\Delta$  or dotted line with mark  $\Delta$  are critical for safety. Replace only with part number specified.

**Note:**  
Les composants identifiés par une marque  $\Delta$  sont critiques pour la sécurité. Ne les remplacer que par une pièce portant le numéro spécifié.

## MAIN

Ref. No.	Part No.	Description	Remarks	Ref. No.	Part No.	Description	Remarks
R212	1-259-428-11	CARBON	1K 5% 1/6W	R518	1-249-427-11	CARBON	6.8K 5% 1/4W
R215	1-249-421-11	CARBON	2.2K 5% 1/4W	R519	1-249-437-11	CARBON	47K 5% 1/4W
R221	1-259-466-11	CARBON	39K 5% 1/6W(K679ES)	R520	1-249-434-11	CARBON	27K 5% 1/4W
R221	1-259-476-11	CARBON	100K 5% 1/6W(K690)	R521	1-247-704-11	CARBON	220 5% 1/4W
R222	1-259-402-11	CARBON	82 5% 1/6W	R522	1-247-704-11	CARBON	220 5% 1/4W
R223	1-259-479-11	CARBON	130K 5% 1/6W	R523	1-249-429-11	CARBON	10K 5% 1/4W
R224	1-259-446-11	CARBON	5.6K 5% 1/6W	R524	1-249-429-11	CARBON	10K 5% 1/4W
R225	1-259-434-11	CARBON	1.8K 5% 1/6W	R525	1-249-429-11	CARBON	10K 5% 1/4W
R226	1-259-435-11	CARBON	2K 5% 1/6W	R526	1-249-422-11	CARBON	2.7K 5% 1/4W
R227	1-259-484-11	CARBON	220K 5% 1/6W	R527	1-249-437-11	CARBON	47K 5% 1/4W
R231	1-249-429-11	CARBON	10K 5% 1/4W	R528	1-249-441-11	CARBON	100K 5% 1/4W
R232	1-249-429-11	CARBON	10K 5% 1/4W	R529	1-249-431-11	CARBON	15K 5% 1/4W
R233	1-249-429-11	CARBON	10K 5% 1/4W	R531	1-259-428-11	CARBON	1K 5% 1/6W
R234	1-259-461-11	CARBON	24K 5% 1/6W	R532	1-215-455-00	METAL	27K 1% 1/6W
R235	1-259-422-11	CARBON	560 5% 1/6W	R533	1-249-437-11	CARBON	47K 5% 1/4W
R236	1-259-452-11	CARBON	10K 5% 1/6W	R534	1-249-441-11	CARBON	100K 5% 1/4W
R237	1-259-476-11	CARBON	100K 5% 1/6W	R535	1-215-454-00	METAL	24K 1% 1/6W
R241	1-259-444-11	CARBON	4.7K 5% 1/6W	R563	1-249-441-11	CARBON	100K 5% 1/4W
R242	1-259-442-11	CARBON	3.9K 5% 1/6W	R564	1-249-429-11	CARBON	10K 5% 1/4W
R243	1-259-440-11	CARBON	3.3K 5% 1/6W	R565	1-249-441-11	CARBON	100K 5% 1/4W
R244	1-259-452-11	CARBON	10K 5% 1/6W	R566	1-249-428-11	CARBON	8.2K 5% 1/4W
R245	1-249-421-11	CARBON	2.2K 5% 1/4W	R567	1-249-441-11	CARBON	100K 5% 1/4W
R246	1-259-444-11	CARBON	4.7K 5% 1/6W	R568	1-249-423-11	CARBON	3.3K 5% 1/4W
R251	1-249-433-11	CARBON	22K 5% 1/4W	R569	1-249-441-11	CARBON	100K 5% 1/4W
R252	1-249-421-11	CARBON	2.2K 5% 1/4W	R570	1-249-429-11	CARBON	10K 5% 1/4W
R253	1-247-862-11	CARBON	20K 5% 1/4W	R571	1-249-429-11	CARBON	10K 5% 1/4W
R254	1-249-409-11	CARBON	220 5% 1/4W	R572	1-249-417-11	CARBON	1K 5% 1/4W
R261	1-249-434-11	CARBON	27K 5% 1/4W	R581	1-249-429-11	CARBON	10K 5% 1/4W
R262	1-247-874-11	CARBON	62K 5% 1/4W	R582	1-249-429-11	CARBON	10K 5% 1/4W
R263	1-249-410-11	CARBON	270 5% 1/4W	R583	1-247-826-00	CARBON	620 5% 1/4W(K679ES)
R281	1-249-428-11	CARBON	8.2K 5% 1/4W(K679ES)	R583	1-247-822-11	CARBON	430 5% 1/4W(K690)
R281	1-249-427-11	CARBON	6.8K 5% 1/4W(K690)	R584	1-247-834-11	CARBON	1.3K 5% 1/4W(K679ES)
R282	1-249-435-11	CARBON	33K 5% 1/4W	R584	1-249-417-11	CARBON	1K 5% 1/4W(K690)
△R283	1-219-153-11	FUSIBLE	10 5% 1/4W F	R585	1-247-872-11	CARBON	51K 5% 1/4W(K679ES)
R284	1-247-883-00	CARBON	150K 5% 1/4W	R585	1-247-862-11	CARBON	20K 5% 1/4W(K690)
R501	1-259-428-11	CARBON	1K 5% 1/6W	R586	1-249-417-11	CARBON	1K 5% 1/4W
R502	1-215-455-00	METAL	27K 1% 1/6W	R587	1-249-436-11	CARBON	39K 5% 1/4W
R505	1-249-427-11	CARBON	6.8K 5% 1/4W	R588	1-249-436-11	CARBON	39K 5% 1/4W
R506	1-249-381-11	CARBON	1 5% 1/4W	R589	1-249-391-11	CARBON	6.8 5% 1/4W
R507	1-247-848-11	CARBON	5.1K 5% 1/4W	R590	1-249-391-11	CARBON	6.8 5% 1/4W
R508	1-249-433-11	CARBON	22K 5% 1/4W	R591	1-249-421-11	CARBON	2.2K 5% 1/4W
R509	1-249-436-11	CARBON	39K 5% 1/4W	R592	1-249-429-11	CARBON	10K 5% 1/4W
R510	1-249-421-11	CARBON	2.2K 5% 1/4W	R601	1-249-440-11	CARBON	82K 5% 1/4W(K679ES)
R511	1-249-421-11	CARBON	2.2K 5% 1/4W	R601	1-249-439-11	CARBON	68K 5% 1/4W(K690)
R512	1-249-441-11	CARBON	100K 5% 1/4W	R602	1-249-435-11	CARBON	33K 5% 1/4W
R513	1-249-441-11	CARBON	100K 5% 1/4W	R603	1-249-439-11	CARBON	68K 5% 1/4W(K679ES)
R514	1-247-836-11	CARBON	1.6K 5% 1/4W	R603	1-249-437-11	CARBON	47K 5% 1/4W(K690)
R516	1-249-437-11	CARBON	47K 5% 1/4W	R604	1-247-876-11	CARBON	75K 5% 1/4W(K679ES)
R517	1-249-433-11	CARBON	22K 5% 1/4W	R604	1-247-874-11	CARBON	62K 5% 1/4W(K690)

**Note:**  
The components identified by mark  $\Delta$  or dotted line with mark  $\Delta$  are critical for safety. Replace only with part number specified.

**Note:**  
Les composants identifiés par une marque  $\Delta$  sont critiques pour la sécurité. Ne les remplacer que par une pièce portant le numéro spécifié.

Ref. No.	Part No.	Description	Remarks			Ref. No.	Part No.	Description	Remarks		
R605	1-249-439-11	CARBON	68K	5%	1/4W (K679ES)	R729	1-249-435-11	CARBON	33K	5%	1/4W
R605	1-249-441-11	CARBON	100K	5%	1/4W (K690)	R730	1-249-435-11	CARBON	33K	5%	1/4W
R606	1-249-433-11	CARBON	22K	5%	1/4W	R731	1-249-425-11	CARBON	4.7K	5%	1/4W
R607	1-247-874-11	CARBON	62K	5%	1/4W	R732	1-249-417-11	CARBON	1K	5%	1/4W
R608	1-249-437-11	CARBON	47K	5%	1/4W	R733	1-247-903-00	CARBON	1M	5%	1/4W
R609	1-247-882-11	CARBON	130K	5%	1/4W (K679ES)	R735	1-249-421-11	CARBON	2.2K	5%	1/4W
R609	1-247-880-11	CARBON	110K	5%	1/4W (K690)	△R736	1-212-942-00	FUSIBLE	2.2	5%	1/2W F
R610	1-247-876-11	CARBON	75K	5%	1/4W (K679ES)	R737	1-249-429-11	CARBON	10K	5%	1/4W
R610	1-247-878-00	CARBON	91K	5%	1/4W (K690)	R738	1-249-429-11	CARBON	10K	5%	1/4W
R611	1-249-438-11	CARBON	56K	5%	1/4W (K679ES)	R739	1-249-429-11	CARBON	10K	5%	1/4W
R611	1-249-439-11	CARBON	68K	5%	1/4W (K690)	R740	1-249-425-11	CARBON	4.7K	5%	1/4W
R612	1-247-887-00	CARBON	220K	5%	1/4W	R742	1-249-441-11	CARBON	100K	5%	1/4W
R613	1-247-876-11	CARBON	75K	5%	1/4W (K679ES)	R743	1-249-441-11	CARBON	100K	5%	1/4W
R613	1-249-439-11	CARBON	68K	5%	1/4W (K690)	R744	1-249-441-11	CARBON	100K	5%	1/4W
R614	1-247-872-11	CARBON	51K	5%	1/4W	R745	1-249-432-11	CARBON	18K	5%	1/4W
R616	1-249-437-11	CARBON	47K	5%	1/4W (K679ES)	R746	1-249-429-11	CARBON	10K	5%	1/4W
R616	1-247-874-11	CARBON	62K	5%	1/4W (K690)	R747	1-249-429-11	CARBON	10K	5%	1/4W
R617	1-249-440-11	CARBON	82K	5%	1/4W (K679ES)	R748	1-249-429-11	CARBON	10K	5%	1/4W
R617	1-247-874-11	CARBON	62K	5%	1/4W (K690)	R749	1-247-862-11	CARBON	20K	5%	1/4W
R618	1-247-883-00	CARBON	150K	5%	1/4W (K679ES)	R750	1-247-866-11	CARBON	30K	5%	1/4W
R618	1-247-886-11	CARBON	200K	5%	1/4W (K690)	R752	1-249-441-11	CARBON	100K	5%	1/4W
R619	1-249-435-11	CARBON	33K	5%	1/4W	R753	1-249-441-11	CARBON	100K	5%	1/4W
R701	1-247-887-00	CARBON	220K	5%	1/4W	R754	1-249-441-11	CARBON	100K	5%	1/4W
R702	1-247-887-00	CARBON	220K	5%	1/4W	R755	1-249-441-11	CARBON	100K	5%	1/4W
R703	1-249-436-11	CARBON	39K	5%	1/4W	R770	1-249-441-11	CARBON	100K	5%	1/4W
R704	1-247-887-00	CARBON	220K	5%	1/4W	R802	1-249-425-11	CARBON	4.7K	5%	1/4W
R705	1-249-436-11	CARBON	39K	5%	1/4W	R803	1-249-420-11	CARBON	1.8K	5%	1/4W
R706	1-247-887-00	CARBON	220K	5%	1/4W	R804	1-249-412-11	CARBON	390	5%	1/4W
R707	1-249-431-11	CARBON	15K	5%	1/4W	R805	1-249-427-11	CARBON	6.8K	5%	1/4W
R708	1-247-868-11	CARBON	36K	5%	1/4W	R806	1-249-419-11	CARBON	1.5K	5%	1/4W
R709	1-249-435-11	CARBON	33K	5%	1/4W	R807	1-259-452-11	CARBON	10K	5%	1/6W
R710	1-249-435-11	CARBON	33K	5%	1/4W	R808	1-259-432-11	CARBON	1.5K	5%	1/6W
R711	1-247-872-11	CARBON	51K	5%	1/4W	R809	1-249-425-11	CARBON	4.7K	5%	1/4W
R712	1-249-435-11	CARBON	33K	5%	1/4W	R810	1-249-409-11	CARBON	220	5%	1/4W
R713	1-249-435-11	CARBON	33K	5%	1/4W	R811	1-259-428-11	CARBON	1K	5%	1/6W
R714	1-249-435-11	CARBON	33K	5%	1/4W	R812	1-259-448-11	CARBON	6.8K	5%	1/6W
R715	1-249-435-11	CARBON	33K	5%	1/4W	R813	1-259-448-11	CARBON	6.8K	5%	1/6W
R716	1-249-435-11	CARBON	33K	5%	1/4W	R814	1-249-417-11	CARBON	1K	5%	1/4W
R717	1-249-435-11	CARBON	33K	5%	1/4W	R815	1-249-425-11	CARBON	4.7K	5%	1/4W
R719	1-249-429-11	CARBON	10K	5%	1/4W	R816	1-249-425-11	CARBON	4.7K	5%	1/4W
△R720	1-212-954-11	FUSIBLE	6.8	5%	1/2W F	R817	1-249-425-11	CARBON	4.7K	5%	1/4W
R721	1-249-429-11	CARBON	10K	5%	1/4W	R818	1-249-433-11	CARBON	22K	5%	1/4W
R722	1-249-431-11	CARBON	15K	5%	1/4W	R819	1-249-436-11	CARBON	39K	5%	1/4W
R723	1-247-834-11	CARBON	1.3K	5%	1/4W	R820	1-249-429-11	CARBON	10K	5%	1/4W
R724	1-249-424-11	CARBON	3.9K	5%	1/4W	R821	1-249-437-11	CARBON	47K	5%	1/4W
R725	1-247-834-11	CARBON	1.3K	5%	1/4W	△R825	1-219-135-11	FUSIBLE	0.15	10%	1/4W
R726	1-249-427-11	CARBON	6.8K	5%	1/4W	△R826	1-219-137-11	FUSIBLE	0.33	10%	1/4W
R727	1-249-430-11	CARBON	12K	5%	1/4W						
△R728	1-212-952-00	FUSIBLE	5.6	5%	1/2W F						

**Note:**

The components identified by mark △ or dotted line with mark △ are critical for safety. Replace only with part number specified.

**Note:**

Les composants identifiés par une marque △ sont critiques pour la sécurité. Ne les remplacer que par une pièce portant le numéro spécifié.

**MAIN REEL MOTOR**

Ref. No.	Part No.	Description	Remarks
< VARIABLE RESISTOR >			
RV121	1-238-015-11	RES, ADJ, CARBON 4.7K	
RV141	1-238-017-11	RES, ADJ, CARBON 22K	
RV181	1-238-017-11	RES, ADJ, CARBON 22K	
RV221	1-238-015-11	RES, ADJ, CARBON 4.7K	
RV241	1-238-017-11	RES, ADJ, CARBON 22K	
RV281	1-238-017-11	RES, ADJ, CARBON 22K	
RV501	1-241-403-11	RES, VAR, CARBON 50K/50K (REC LEVEL)	
RV502	1-238-904-11	RES, VAR, CARBON 50K/50K (BALANCE)	
RV503	1-241-404-11	RES, VAR, CARBON 5K/5K (REC LEVEL)	
RV504	1-238-015-11	RES, ADJ, CARBON 4.7K	
RV505	1-238-085-11	REA, VAR, CARBON 20K/20K (PHONE LEVEL)	
RV506	1-241-747-11	RES, VAR, CARBON 10K (BIAS)	
RV508	1-238-021-11	RES, ADJ, CARBON 220K (K679ES)	
RV508	1-238-022-51	RES, ADJ, CARBON 330K (K690)	
< SWITCH >			
S501	1-572-154-11	SWITCH, ROTARY (DOLBY NR)	
S502	1-554-118-00	SWITCH, PUSH (1 KEY) (MPX FILTER)	
S701	1-571-520-11	SWITCH, SLIDE (TIMER)	
S801	1-554-118-00	SWITCH, PUSH (1 KEY) (POWER)	
< TRANSFORMER >			
T181	1-433-344-11	TRANSFORMER, BIAS OSCILLATION	
T281	1-433-344-11	TRANSFORMER, BIAS OSCILLATION	
T501	1-433-380-11	TRANSFORMER, BIAS OSCILLATION	
< VIBRATOR >			
X701	1-577-359-21	VIBRATOR, CERAMIC 4.19MHz	
*****			
*	1-632-741-11	REEL MOTOR BOARD	
*****			
< CAPACITOR >			
C1051	1-124-907-11	ELECT 10uF 20% 50V	
C1052	1-124-907-11	ELECT 10uF 20% 50V	
C1053	1-164-159-11	CERAMIC 0.1uF 50V	
< CONNECTOR >			
* CN1051	1-564-499-11	PIN, CONNECTOR 6P	
* CN1052	1-564-718-11	PIN, CONNECTOR (SMALL TYPE) 2P	
* CN1053	1-564-718-11	PIN, CONNECTOR (SMALL TYPE) 2P	
< RESISTOR >			
R1051	1-249-414-11	CARBON 560 5% 1/4W	
*****			

Ref. No.	Part No.	Description	Remarks
MISCELLANEOUS			
*****			
△12	1-555-795-00	CORD, POWER, EULO PLUG (K690:AEP, Germany)	
△12	1-556-035-00	CORD, POWER (K679ES:UK)	
△12	1-558-945-11	CORD, POWER (POLAR. SPT-1) (K679ES:US, Canadian/K690:US)	
* 125	1-608-268-00	PC BOARD, ERASE HEAD	
D1051	8-719-980-85	DIODE SLF325C	
HE1001	1-543-836-11	HEAD, MAGNETIC (ERASE)	
HRP1001	1-543-834-11	HEAD, MAGNETIC (REC/PB) (K690)	
HRP1001	1-543-835-11	HEAD, MAGNETIC (REC PB) (K679ES)	
M1051	X-3356-638-1	MOTOR (REEL R) ASSY	
M1052	X-3356-604-1	MOTOR (ASSIST) ASSY	
M1053	X-3356-635-1	MOTOR (CAPSTAN R2) ASSY	
S1001	1-466-238-11	ENCODER, ROTARY	
△T901	1-450-100-11	TRANSFORMER, POWER (K679ES:US, Canadian /690:US)	
△T901	1-450-399-11	TRANSFORMER, POWER (K679ES:UK /K690:AEP, Germany)	
*****			
ACCESSORIES & PACKING MATERIALS			
*****			
	1-558-271-11	CORD, CONNECTION	
	1-558-271-11	CORD, CONNECTION	
*	3-350-830-01	CUSHION (K690)	
*	3-376-443-41	INDIVIDUAL CARTON (K690)	
	3-755-069-21	MANUAL, INSTRUCTION (ENGLISH) (K679ES)	
	3-755-069-31	MANUAL, INSTRUCTION (FRENCH) (K679ES:Canadian)	
	3-755-084-11	MANUAL, INSTRUCTION (ENGLISH, FRENCH, SPANISH) (K690:AEP)	
	3-755-084-21	MANUAL, INSTRUCTION (ENGLISH) (K690:US)	
	3-755-084-41	MANUAL, INSTRUCTION (GERMAN, DUTCH, SWEDISH, ITALIAN, PORTUGUESE) (K690:AEP)	
	3-755-084-51	MANUAL, INSTRUCTION (GERMAN) (K690:Germany)	
	3-793-481-13	INSTRUCTION	
	9-910-999-33	INSTRUCTION (K679ES:US/K690:US)	
*****			

<p><b>Note:</b> The components identified by mark △ or dotted line with mark △ are critical for safety. Replace only with part number specified.</p>	<p><b>Note:</b> Les composants identifiés par une marque △ sont critiques pour la sécurité. Ne les remplacer que par une pièce portant le numéro spécifié.</p>
--	--

<u>Ref. No.</u>	<u>Part No.</u>	<u>Description</u>	<u>Remarks</u>
-----------------	-----------------	--------------------	----------------

**HARDWARE LIST**

\*\*\*\*\*

#1	7-685-534-19	SCREW +BTP 2.6X8 TYPE2 N-S	
#2	7-682-547-04	SCREW +BVTT 3X6 (S)	
#3	7-682-548-09	SCREW +BVTT 3X8 (S)	
#4	7-621-849-00	SCREW (BV/RING)	
#5	7-671-154-01	STENLESS BALL	
#6	7-628-253-00	SCREW +PS 2X4	
#7	7-685-133-19	SCREW +BTP 2.6X6 TYPE2 N-S	
#8	7-621-255-20	SCREW +BVTT 2X4 (S)	
#10	7-621-772-70	SCREW +B 2X14	
#11	7-622-205-05	NUT M2 TYPE2	
#12	7-621-772-18	SCREW +B 2X4	
#13	7-621-773-86	SCREW +B 2.6X4 (K679ES)	
#13	7-621-775-10	SCREW +B 2.6X4 (K690)	
#14	7-621-255-35	SCREW +BVTT 2X5 (S)	
#15	7-682-647-09	SCREW +PS 3X6	
#16	7-685-870-01	SCREW +BVTT 3X5 (S)	

