

TC-K715S/K717ES/K815S

SERVICE MANUAL

Ver 1.1 2001.06

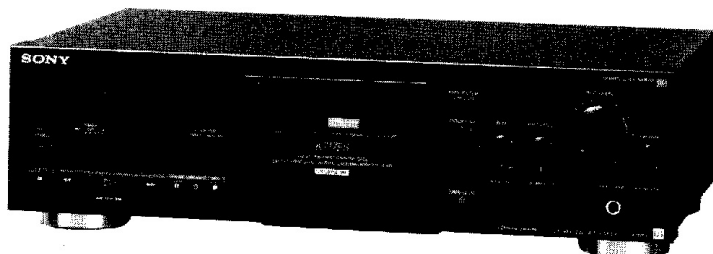

Photo: TC-K717ES

US Model
Canadian Model

TC-K717ES

AEP Model

TC-K715S/K815S

UK Model

TC-K715S

E Model

TC-K717ES

Australian Model

TC-K715S

Dolby noise reduction manufactured under license from Dolby Laboratories Licensing Corporation.
"DOLBY" and the double-D symbol **DD** are trademarks of Dolby Laboratories Licensing Corporation.

Model Name Using Similar Mechanism		TC-K611S/K707ES/K711S
Tape Transport Mechanism Type	TC-K715S	TCM-200V18
	TC-K717ES	TCM-200V19
	TC-K815S	TCM-200V20

SPECIFICATIONS

Recording system	4-track 2-channel stereo
Fast winding time	Approx. 90 sec. (with Sony C-60 cassette)
Bias	AC bias
Heads	Erasing head × 1 (TC-K717ES/K815S: S&F head, K715S: F&F head) Recording head × 1 (SD head) Playback head × 1 (TC-K715S/K815S: SD head, K717ES: LA head)
Motors	Capstan motor × 1 (DC servo motor) Reel motor × 1 (DC motor) Assist (mechanism drive) motor × 1 (DC motor)

Frequency response (Dolby NR off)

Type IV cassette	TC-K717ES: 20–21,000Hz (±3dB, IEC) TC-K715S/K815S: 20–20,000Hz (±3dB, IEC) 20–16,000Hz [±3dB (–4dB recording)]
Type II cassette	TC-K717ES: 20–19,000Hz (±3dB, IEC) TC-K715S/K815S: 20–18,000Hz (±3dB, IEC)
Type I cassette	20–17,000Hz (±3dB, IEC)

Type IV: Sony Type IV (METAL)

Type II: Sony Type II (HIGH)

Type I: Sony Type I (NORMAL)

Wow and flutter	±0.06% W. Peak (IEC) (TC-K717ES/K815S)
	±0.065% W. Peak (IEC) (TC-K715S)
	0.04% W. RMS (NAB) (TC-K717ES/K815S)
	0.045% W. RMS (NAB) (TC-K715S)
	±0.11% W. Peak (DIN) (TC-K717ES/K815S)
	±0.12% W. Peak (DIN) (TC-K715S)

Signal-to-noise ratio (at peak level and weighted)

Cassette (Dolby NR off)	Type IV	Type II	Type I
	61 dB	59 dB	57 dB

S/N ratio improvement (approximate values)

With Dolby B NR on: 5 dB at 1 kHz; 10 dB at 5 kHz
With Dolby C NR on: 15 dB at 500 Hz; 20 dB at 1 kHz
With Dolby S NR on: 10 dB at 100 Hz; 24 dB at 1 kHz

Harmonic distortion	0.4% (with Type I, 160 nWb/m, 315 Hz, 3rd H.D.)
	1.5% (with Type IV, 250 nWb/m, 315 Hz, 3rd H.D.)

—Continued on next page—

STEREO CASSETTE DECK
SONY®

Inputs

Line inputs (phono jacks)	Sensitivity	0.16 V
	Input impedance	47 k ohms

Outputs

Line outputs (phono jacks)	Rated output level	0.5 V at a load impedance of 47 k ohms
	Load impedance	Over 10 k ohms
Headphones (stereo phone jack)	Output level	0 - 3 mW at a load impedance of 32 ohms

General

Power requirements US, Canadian model : 120V AC, 60Hz
 AEP, German model : 220—230V AC, 50/60Hz
 UK model : 240V AC, 50Hz
 E model : 120V, 220V and 240V AC adjustable, 50/60Hz
 Australian model : 240V AC, 50/60Hz

Power consumption 21 W

Dimensions Approx. 430 × 123 × 306 mm (w/h/d)
 (17 × 4⁷/₈ × 12¹/₈ inches)
 including projecting parts and controls

Mass TC-K717ES/K815S :
 Approx. 4.9kg (10 lbs 13 oz)
 TC-K715S :
 Approx. 4.7kg (10 lbs 6 oz)

Supplied accessories

Audio connecting cords (2)

Design and specifications are subject to change without notice.

MODEL IDENTIFICATION

—Specification Label—

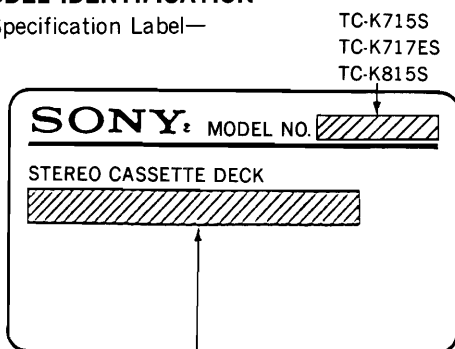

US, Canadian model : AC 120V 60Hz 21W
 AEP, German model : AC 220—230V~50/60Hz 21W
 UK model : AC 240V~50Hz
 E model : AC 120, 220, 240V~50/60Hz 21W
 Australian model : AC 240V~50/60Hz

SAFETY-RELATED COMPONENT WARNING!!

COMPONENTS IDENTIFIED BY MARK OR DOTTED LINE WITH MARK ON THE SCHEMATIC DIAGRAMS AND IN THE PARTS LIST ARE CRITICAL TO SAFE OPERATION. REPLACE THESE COMPONENTS WITH SONY PARTS WHOSE PART NUMBERS APPEAR AS SHOWN IN THIS MANUAL OR IN SUPPLEMENTS PUBLISHED BY SONY.

SAFETY CHECK-OUT (US Model)

After correcting the original service problem, perform the following safety check before releasing the set to the customer:

Check the antenna terminals, metal trim, “metallized” knobs, screws, and all other exposed metal parts for AC leakage. Check leakage as described below.

LEAKAGE TEST

The AC leakage from any exposed metal part to earth ground and from all exposed metal parts to any exposed metal part having a return to chassis, must not exceed 0.5 mA (500 microamperes). Leakage current can be measured by any one of three methods.

1. A commercial leakage tester, such as the Simpson 229 or RCA WT-540A. Follow the manufacturers' instructions to use these instruments.
2. A battery-operated AC milliammeter. The Data Precision 245 digital multimeter is suitable for this job.
3. Measuring the voltage drop across a resistor by means of a VOM or battery-operated AC voltmeter. The “limit” indication is 0.75 V, so analog meters must have an accurate low-voltage scale. The Simpson 250 and Sanwa SH-63Trd are examples of a passive VOM that is suitable. Nearly all battery operated digital multimeters that have a 2V AC range are suitable. (See Fig. A)

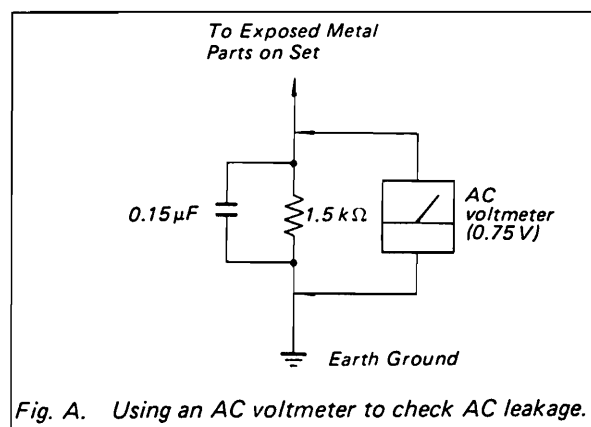

Fig. A. Using an AC voltmeter to check AC leakage.

ATTENTION AU COMPOSANT AYANT RAPPORT À LA SÉCURITÉ!

LES COMPOSANTS IDENTIFIÉS PAR UNE MARQUE SUR LES DIAGRAMMES SCHÉMATIQUES ET LA LISTE DES PIÈCES SONT CRITIQUES POUR LA SÉCURITÉ DE FONCTIONNEMENT. NE REMPLACER CES COMPOSANTS QUE PAR DES PIÈCES SONY DONT LES NUMÉROS SONT DONNÉS DANS CE MANUEL OU DANS LES SUPPLÉMENTS PUBLIÉS PAR SONY.

TABLE OF CONTENTS

<u>Section</u>	<u>Title</u>	<u>Page</u>
1. GENERAL		
	Identifying the Parts on the Front Panel	4
2. DISASSEMBLY		
2-1.	Mechanism Deck Block	5
2-2.	Power Transformer	5
2-3.	Cassette Holder Assy	6
2-4.	Ornamental Plate Assy	6
2-5.	Capstan Motor Assy (TC-K715S)	7
2-6.	Flywheel (V) Assy (TC-K715S)	7
2-7.	Capstan Motor Assy (TC-K717ES/K815S)	8
2-8.	Flywheel Assy (TC-K717ES/K815S).....	8
2-9.	Reel and Assist Motors	9
3. MECHANICAL ADJUSTMENTS		10
4. ELECTRICAL ADJUSTMENTS		13
5. DIAGRAMS		
5-1.	Block Diagram.....	17
5-2.	Circuit Boards Location	21
5-3.	Printed Wiring Boards—Main Section—	23
5-4.	Schematic Diagram—Audio Section—	27
5-5.	Schematic Diagram—System Control Section—.....	31
5-6.	Schematic Diagram—Dolby S Section—	35
5-7.	Printed Wiring Board—Dolby S Section—	36
5-8.	Semiconductor Lead Layouts	37
6. EXPLODED VIEWS		
6-1.	Front Panel Section	38
6-2.	Chassis Section.....	39
6-3.	Mechanism Deck Section 1 (TCM-200V18 : TC-K715S)	40
6-4.	Mechanism Deck Section 2 (TCM-200V18 : TC-K715S)	41
6-5.	Mechanism Deck Section 3 (TCM-200V19 : TC-K717ES) (TCM-200V20 : TC-K815S)	42
6-6.	Mechanism Deck Section 4 (TCM-200V19 : TC-K717ES) (TCM-200V20 : TC-K815S)	43
7. ELECTRICAL PARTS LIST		44

SECTION 1 GENERAL

This section is extracted from instruction manual.

Identifying the Parts on the Front Panel

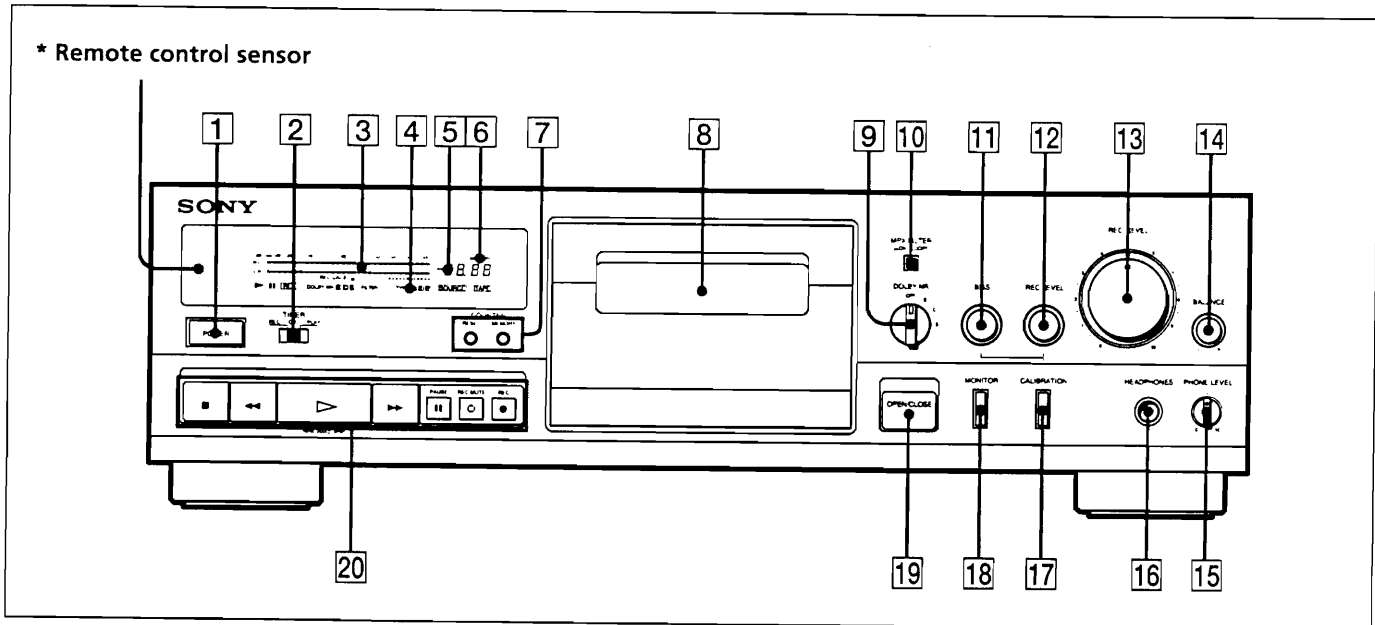



For details, refer to the page number(s) indicated in parentheses.

- 1 POWER switch
- 2 TIMER switch (page 15)
- 3 Peak level meter (page 12)
- 4 Tape TYPE indicator
- 5 Linear counter (page 9)
- 6 MEMORY indicator
- 7 COUNTER buttons
RESET button (page 9)
MEMORY button (pages 9 and 10)
- 8 Cassette holder
- 9 DOLBY NR (noise reduction) switch (pages 7 and 10)
- 10 MPX FILTER button (page 12)
- 11 BIAS control (pages 13 and 14)
- 12 REC (recording) LEVEL control for calibration (pages 13 and 14)
- 13 REC (recording) LEVEL control (pages 11 and 12)
- 14 BALANCE control (page 11)
- 15 PHONE (headphones) LEVEL control (page 7)
- 16 HEADPHONES jack (stereo phone jack) (page 7)
- 17 CALIBRATION button (pages 13 and 14)
- 18 MONITOR button (page 13)
- 19 OPEN/CLOSE button
- 20 Tape operation buttons
 - (stop) button
 - ◀◀ (rewind) (Multi-AMS**) button
 - ▷ (play) button
 - ▶▶ (fast-forward) (Multi-AMS**) button
 - || PAUSE button
 - REC MUTE (record muting) button (page 15)
 - REC (recording) button

*Remote control sensor

You can remotely control this cassette deck with:

- A remote commander that came with a Sony amplifier or receiver if it has the  mark and cassette deck control capability.
- An optional Sony remote commander with the  mark and cassette deck control capability.

** AMS is an abbreviation for Automatic Music Sensor.

SECTION 2 DISASSEMBLY

Note: Follow the disassembly procedure in the numerical order given.

2-1. MECHANISM DECK BLOCK

- ① Open the cassette lid.

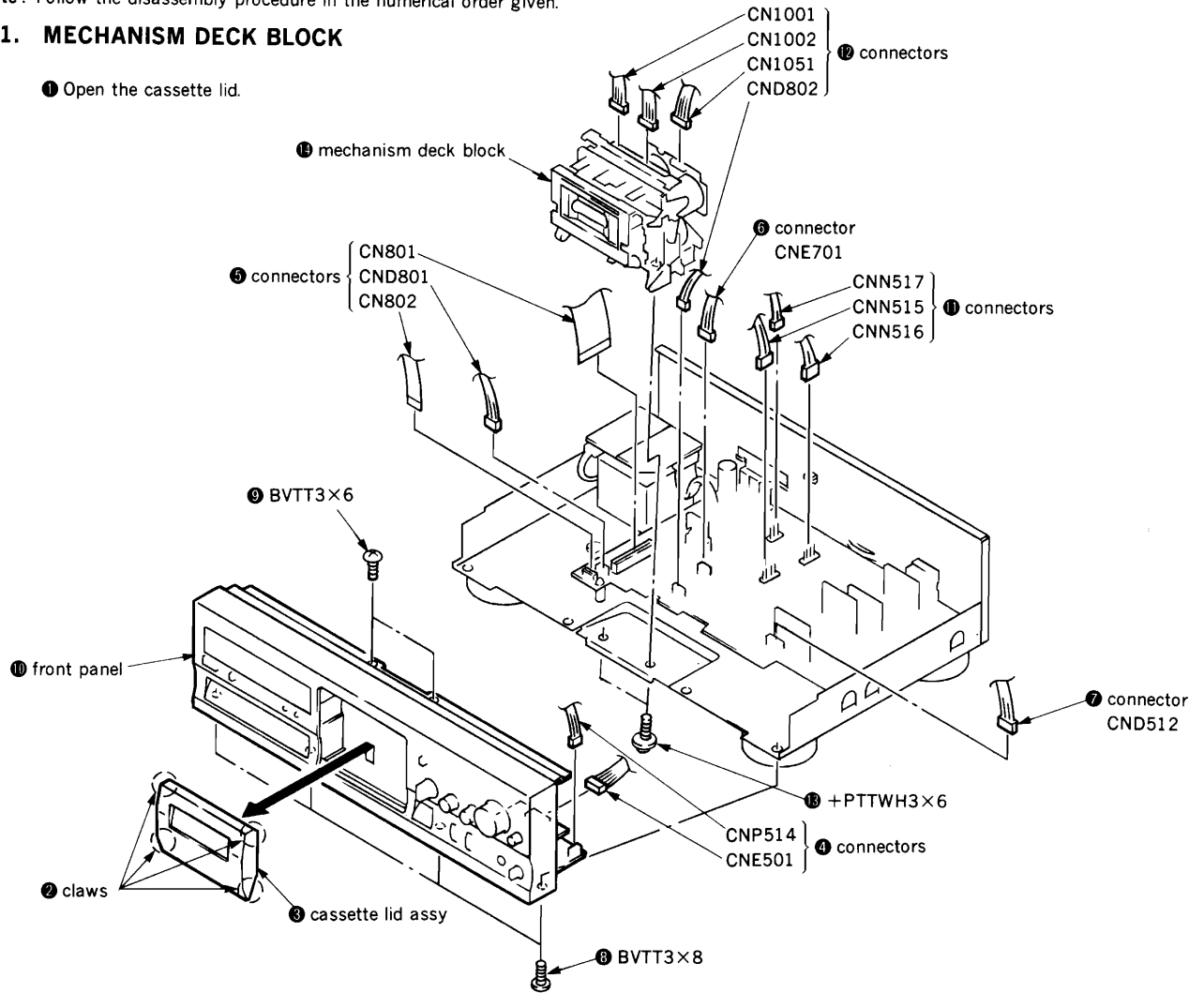

2-2. POWER TRANSFORMER

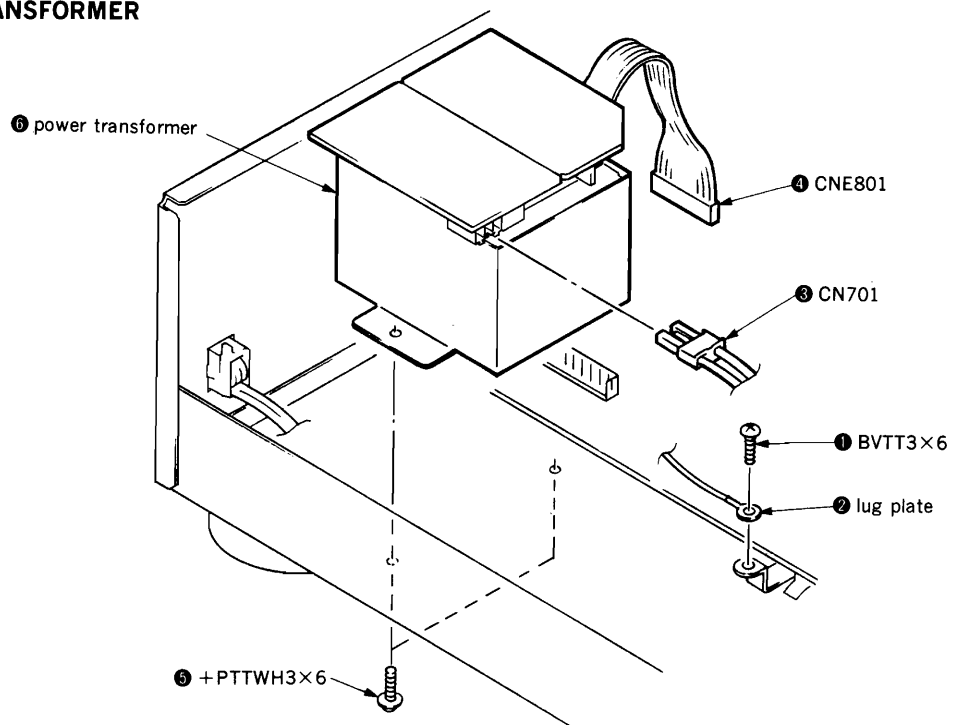

2-3. CASSETTE HOLDER ASSY

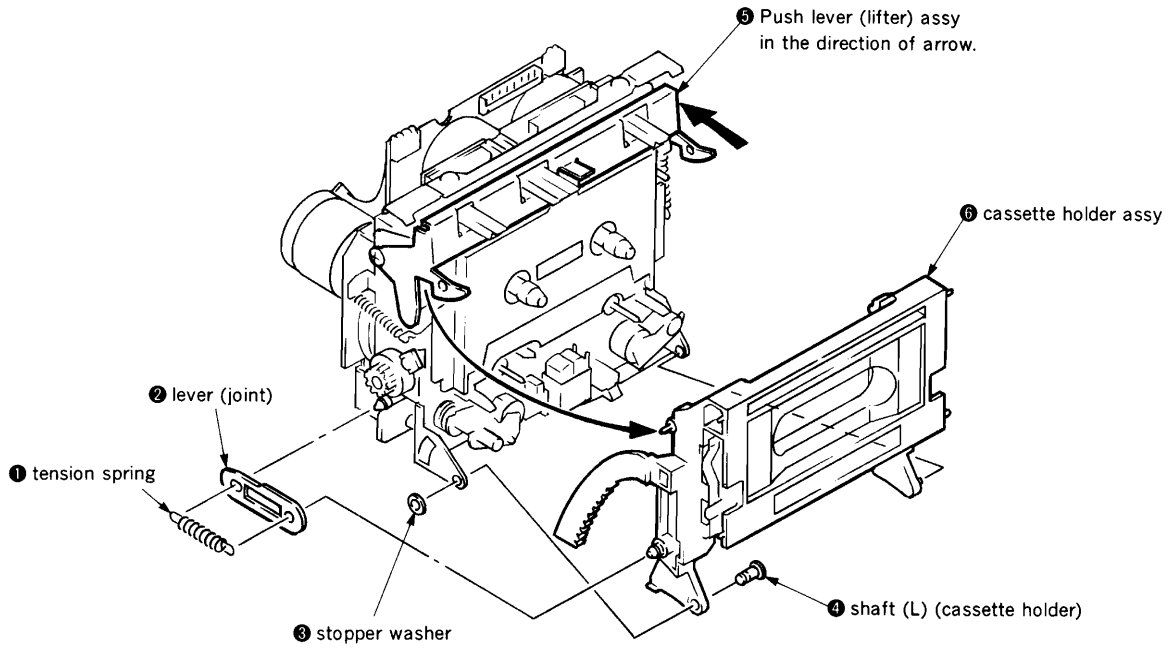

2-4. ORNAMENTAL PLATE ASSY

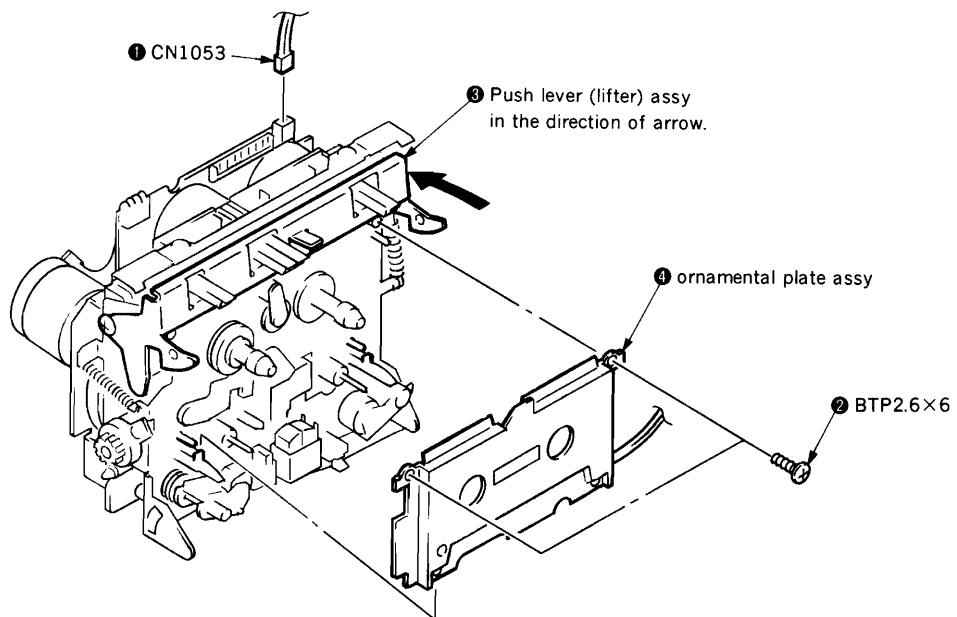

2-5. CAPSTAN MOTOR ASSY (TC-K715S)

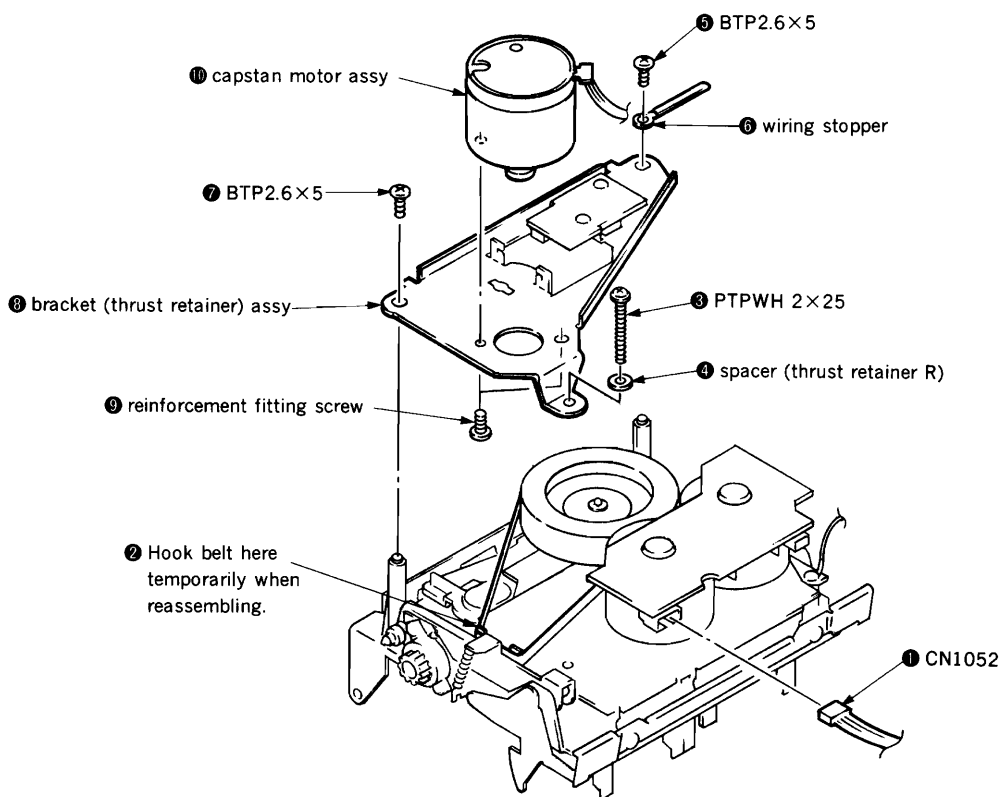

2-6. FLYWHEEL (V) ASSY (TC-K715S)

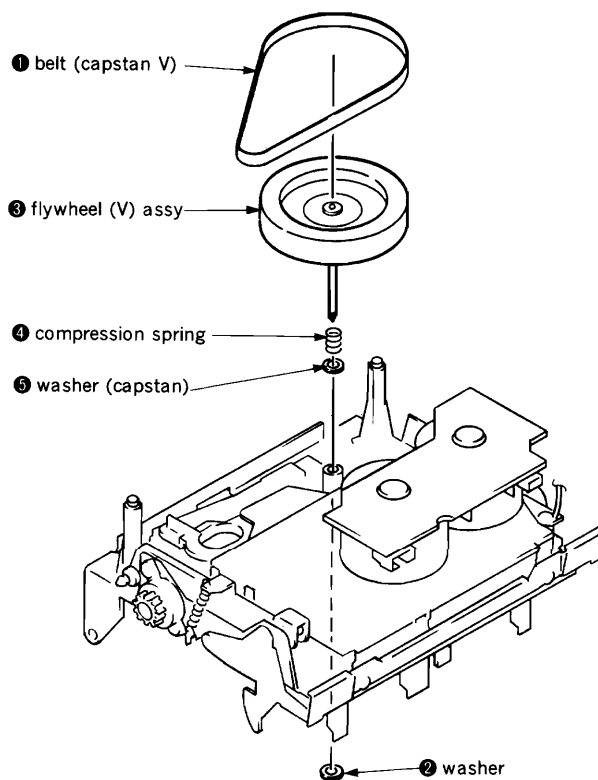

2-7. CAPSTAN MOTOR ASSY (TC-K717ES/K815S)

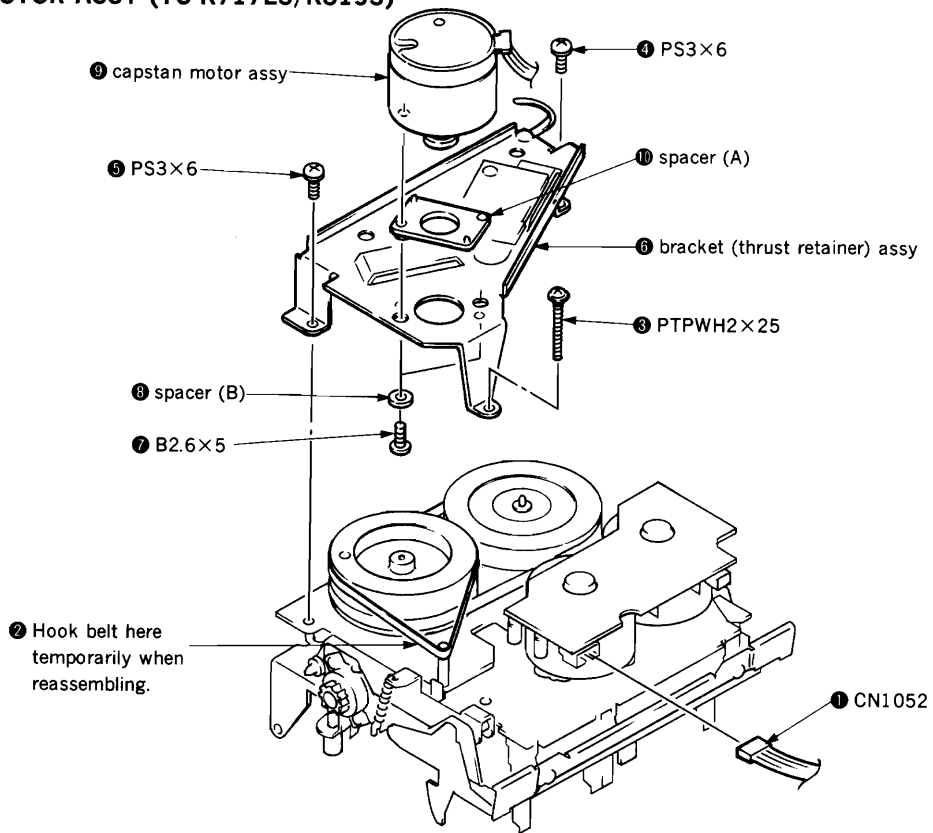

2-8. FLYWHEEL ASSY (TC-K717ES/K815S)

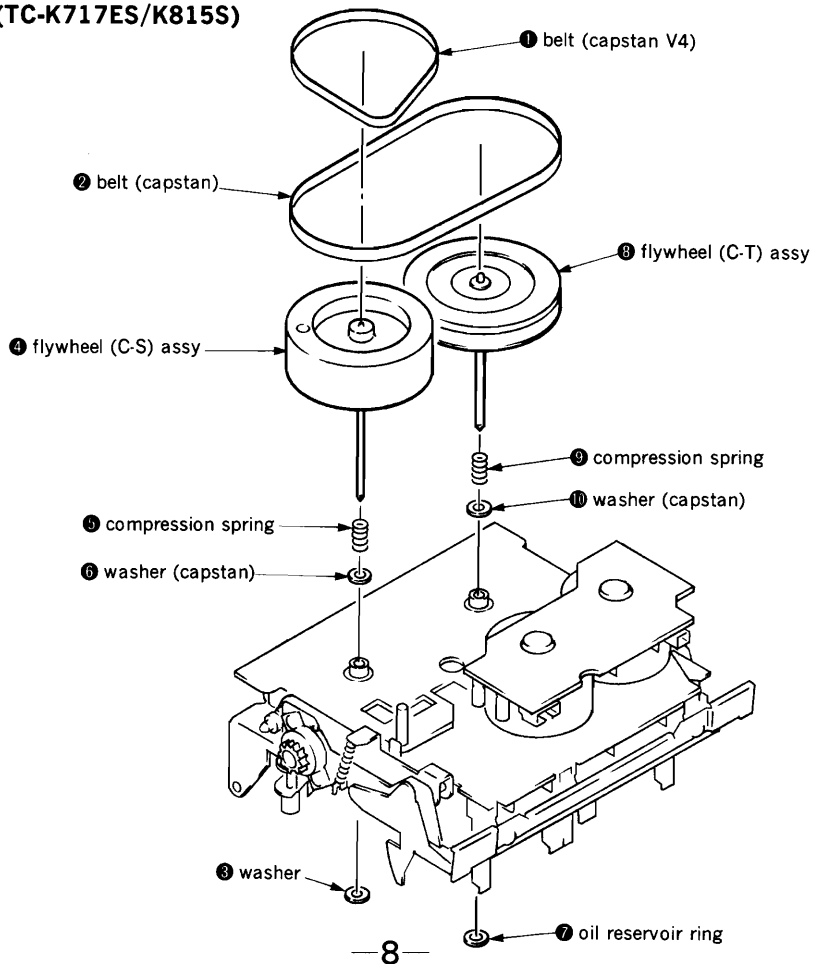

2-9. REEL AND ASSIST MOTORS

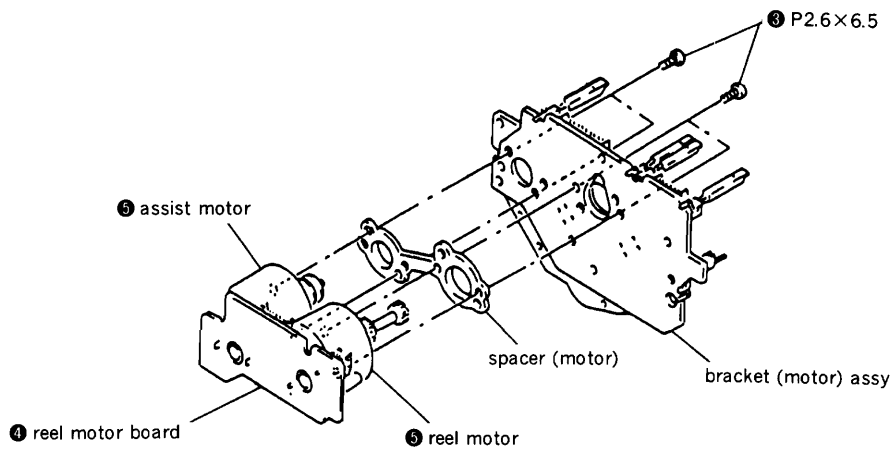
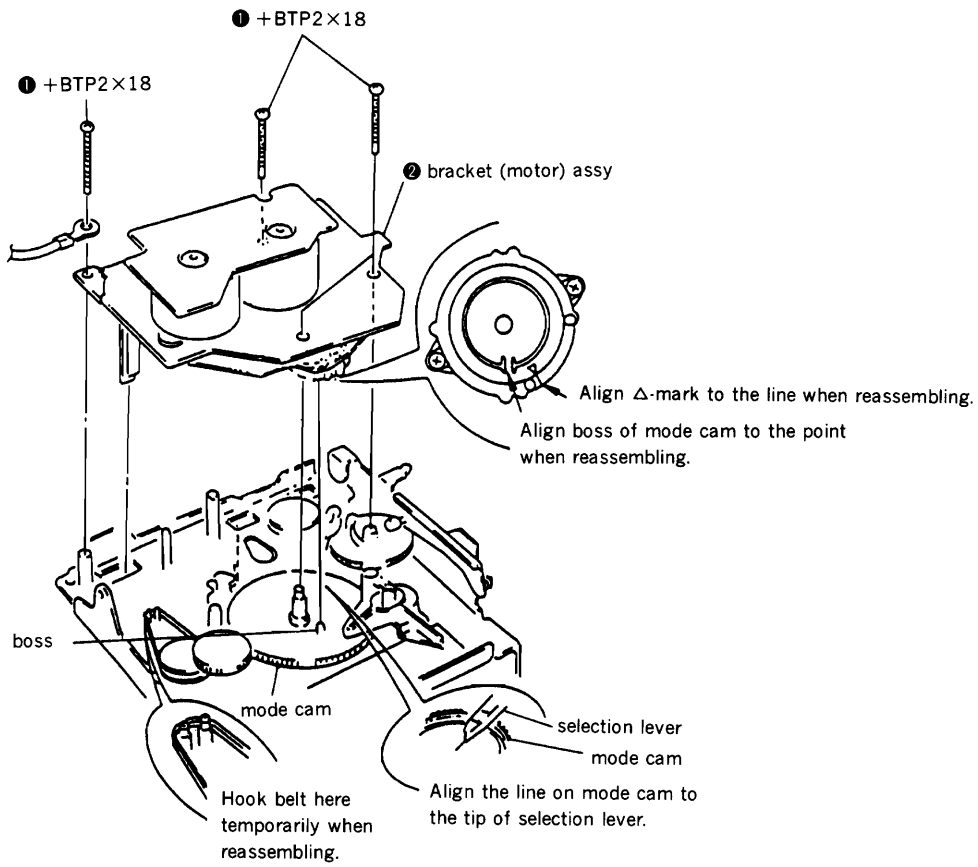

SECTION 3 MECHANICAL ADJUSTMENTS

PRECAUTION

1. Clean the following parts with a denatured-alcohol-moistened swab :

record/playback head	pinch roller
erase head	rubber belts
capstan	idler
2. Demagnetize the record/playback head with a head demagnetizer.
3. Do not use a magnetized screwdriver for the adjustments.
4. After the adjustments, apply suitable locking compound to the parts adjusted.

Tape Path Adjustment

Note : When using the adjustment methods for other than replacement reasons, please do not tamper unnecessarily with the adjustment screws or the erase head because either the supply pinch roller guide or the record/playback head will be made the standard tape paths. Moreover, when it is necessary to adjust and replace two or more of any of the heads and/or pinch rollers, replace them one by one, completely taking out the first tape path, and then replacing the second one.

Preparation :

1. Mirror cassette CQ-009C 8-909-708-01
(or CQ-012C 8-909-708-02)

If one does not have this, cut out the sections of a 120-minute cassette shell as indicated below and use that cassette.

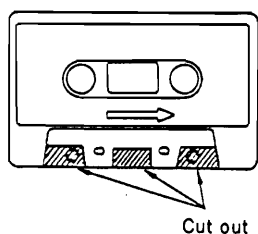

2. Phillips screwdriver (medium-size) :
For the head adjustment screws
- Blade-type screwdriver (large-size) :
For the supply pinch roller adjustment screws
3. Pen light
4. WS-48B (3kHz, 0dB)
5. P-4-A100 (10kHz, -10dB)

Adjustment Position : As seen from the cassette, side (top) and MD as seen head on (bottom).

TC-K717ES/K815S :

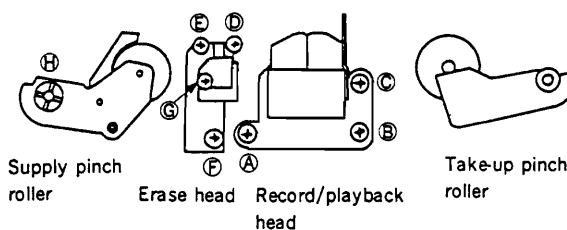
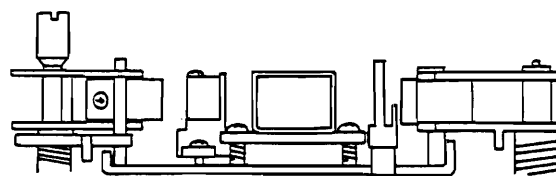

TC-K715S :

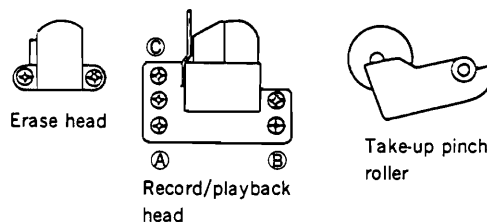
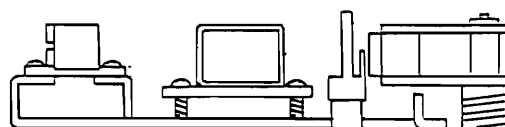

Definition of Terms : The figures are of a record/playback head.

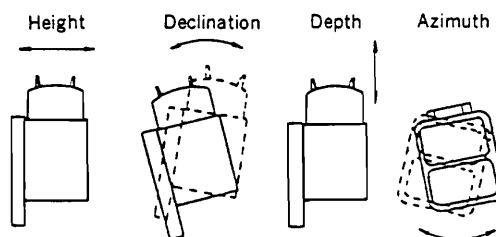

Adjustment Method:

Supply Pinch Roller

Note: Only perform this adjustment when the supply pinch roller is to be replaced.

1. Insert the mirror cassette and put the unit in record/playback mode.
2. Check to see whether the tape is curling at the record/playback head guide or the pinch roller guide.
If it is curling, remove the curl by adjusting the Ⓔ tape curl adjustment screw. Then, check that the tape is running past the middle of the erase head.

Record/playback Head

Note: Only perform this adjustment when the record/playback head is to be replaced.

1. Insert the mirror cassette and put the unit in record/playback mode.
2. (**Height Adjustment**) Check to see if the tape is curling at the tape guide of the head. If it is curling, tighten screws Ⓐ , Ⓑ , and Ⓒ , respectively by the same angle, moving the head so that it remains at the same angle through out the procedure. If it curls on the bottom side of the mirror cassette (actually the inner side), tighten all the screws equally; but loosen them if the tape begins to curl on the top side (outer side).

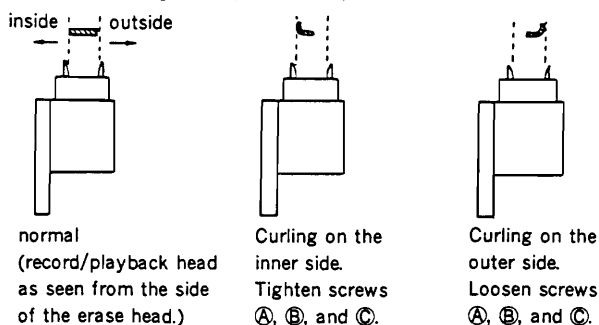

3. (**Declination Adjustment**) While in the record/playback position, set the back tension to 0 (wind the supply reel with something thin like a pencil in a counterclockwise direction) and make sure there is no curling or shifting (shifting up/shifting down) at the guide of the record/playback head.

Because shifting can only occur due to a difference in the width of the tape and that of the tape guides (curling will otherwise occur), it is necessary to pay close attention since it can be easily overlooked.

When there is a shift, tighten screws Ⓑ and Ⓒ equally and change the declination of the head. If the tape is shifting up, tighten the screws, and if it is shifting down, loosen them.

4. Repeat the adjustments in steps 2 and 3 and fine adjust the height and the declination.
5. (**Preliminary Azimuth Adjustment**)
After demagnetizing and cleaning the adjustment head, playback WS-48B (3kHz, 0dB).
Turn screw Ⓒ so that the reading on the level meter of the unit or that of the level meter connected to LINE OUT is maximized.
If the screw is turned at least half a revolution, repeat the adjustments from step 1.
6. (**Tape Path Check**) Connect the oscilloscope to LINE OUT and playback P-4-A100 (10kHz, -10dB) to display a resurge waveform. After 20 seconds of record/playback (after the tension within the loop has been increased sufficiently), make sure the variation in the resurge is within ± 90 degrees (within ± 45 degrees is desired).
If the declination and /or the height adjustment is not perfect. Repeat the adjustments from step 1.

test tape
P-4-A100
(10kHz, -10dB)

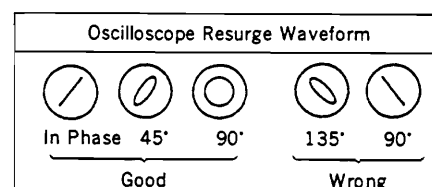
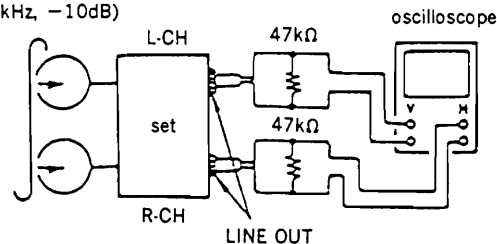

Erase Head

Note: Only perform this adjustment when the erase head is to be replaced.

1. Insert the mirror cassette and put the unit in record/playback mode.
2. (**Azimuth Adjustment**) Adjust the azimuth of the erase head by adjusting screws E and F so that the tape runs as evenly as possible.

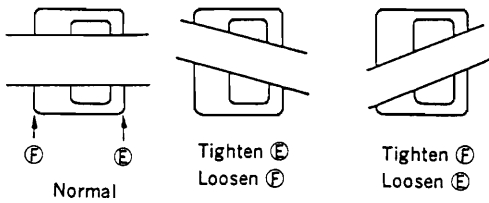

(The erase head as seen when erasing the mirror cassette.)

3. (**Height adjustment**) Turn screws D , E , and F all by the same angle so that the portions of the erase head visible at top and bottom are nearly of equal width. If the width at the top is greater, tighten the screws; if the width at the bottom is greater, loosen the screws.

Erase head (The erase head as seen through the mirror cassette.)

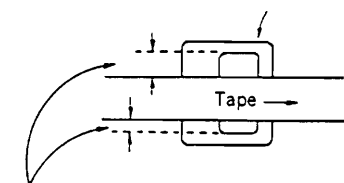

Make these the same width.

4. (**Declination Adjustment**) Leaving it in the playback position, put the back tension to 0 and make certain the erase head part and supply pinch roller guide part do not shift. If there is a shift, turn the screw D and change the declination.

Looking at it using the mirror cassette, if the tape shifts up, tighten the screw, and if it shifts down, loosen the screw.

5. Repeat the adjustments beginning with step 2 and fine adjust the height and declination. And make sure the tape does not curl up on the pinch roller guide or the guide part of the record/playback head.
6. (**Depth Adjustment**) In order to make the entire head play the tape smoothly, and to make sure the depth of the erase head is neither too shallow nor too deep, loosen screw C a bit.

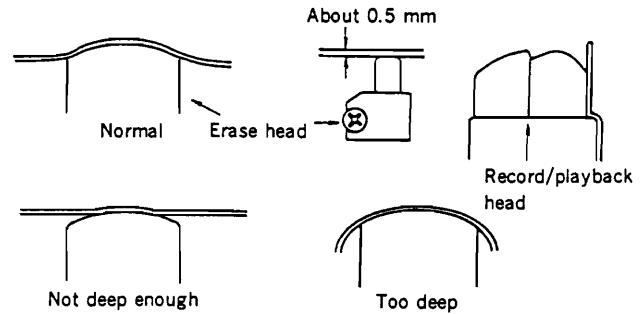

Check

1. Check to make sure that there are no curls or shifts through out the whole tape path and that the tape runs smoothly.
2. Reapply the locking compound to the adjusted screws. (The locking compound should only be applied to screw C after the azimuth has been adjusted.)

Torque Measurement

Torque	Torque meter	Meter reading
FWD	CQ-102C	30—60g·cm (0.42—0.83 oz·inch)
FWD Back tension	CQ-102C	1—5g·cm (0.014—0.069 oz·inch): TC-K715S 7—11 g·cm (0.097—0.153 oz·inch): TC-K717ES/K815S
FF, REW	CQ-201B	65—90g·cm (0.90—1.25 oz·inch)

Pinch Roller Pressing Force Measurement

Mode : playback

Hook needle of the tension gauge to the pinch roller shaft and push back pinch roller to detach it from capstan. Then, return it gradually to capstan and read the gauge when the pinch roller begins turning.

Standard Limits :

210—310g (7.4—10.9 oz)	: TC-K715S
Take-up side : 270—350g (9.5—12.3 oz)	} : TC-K717ES/ K815S
Supply side : 180—280g (6.4—9.9 oz)	

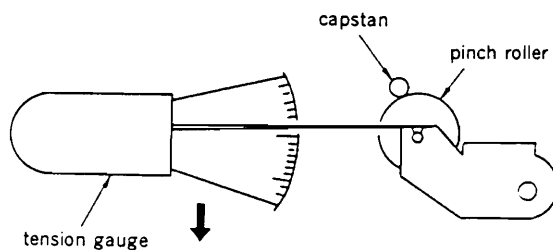

SECTION 4 ELECTRICAL ADJUSTMENTS

Note: The adjustment should be performed in the order given in the service manual. As a rule, adjustments about playback should be performed before those about recording.

The adjustments should be performed before for both L-CH and R-CH.

- Switches and controls should be set as follows unless otherwise specified.

DOLBY NR switch : OFF
 MPX FILTER switch : OFF
 MONITOR switch : Tape
 CALIBRATION switch : OFF

- Standard Record :

Deliver the standard input signal level to the input jack and set the REC LEVEL control to obtain the standard output signal level.

—Record Mode—

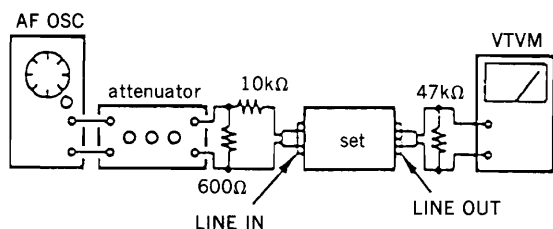

0dB = 775mV

Standard Input Level

input terminal	LINE IN
source impedance	10kΩ
input level	0.5V (-3.8dB)

Standard Output Level

output terminal	LINE OUT
load impedance	47kΩ
output level	0.5V (-3.8dB)

Test Tape

Type	Signal	Used for
P-4-A100	10kHz, -10dB	Azimuth Adjustment
P-4-L300	315Hz, 0dB	PB Level Adjustment
WS-48B	3kHz, 0dB	Tape Speed Adjustment

Test Mode

This set will get into test mode by shorting the pins ① and ② of CNE702 (TEST) on MAIN board before turning the power on.

Record/Playback Head Azimuth Adjustment

Procedure :

- Mode : playback

Test tape
 P-4-A100
 (10kHz, -10dB)

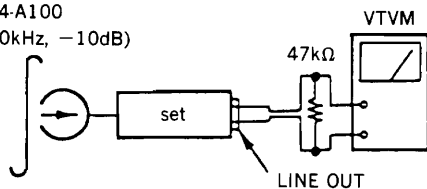

- Turn the adjustment screw for the maximum output levels. If these levels do not match, turn the adjustment screw until both of output levels match together within 1 dB.

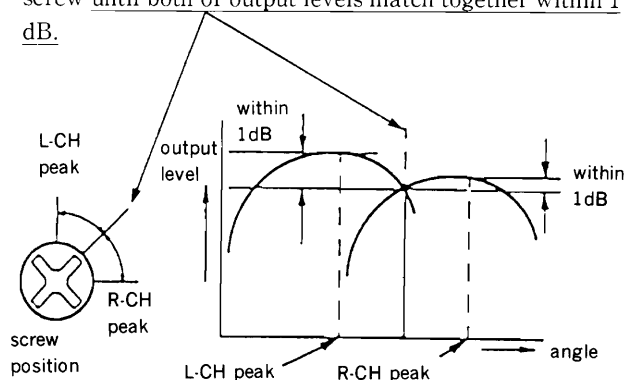

- Phase Check

Mode : playback

test tape

P-4-A100

(10kHz, -10dB)

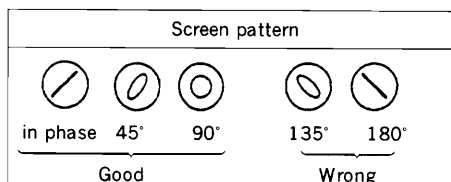
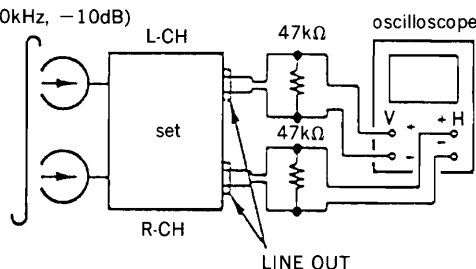

- After the adjustment, lock the screws with locking compound.

Adjustment Location : Record/Playback head

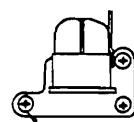

Adjustment screw
 (TC-K717ES/K815S)

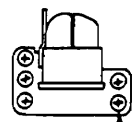

Adjustment screw
 (TC-K715S)

Tape Speed Check

Procedure :

Mode : playback

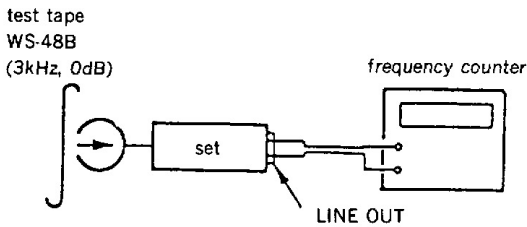

1. Short the connector CNE702 (pins ① and ②). (test mode)
2. Set to FWD playback mode.
3. Confirm that the frequency counter reading becomes $3,000 \pm 30\text{Hz}$.
4. Push the COUNTER RESET switch (S759) on the front panel (FL board).
5. Confirm that the counter display of fluorescent indicator tube (FLT751) is "A1E".

Note : "E" displayed segment may be flicking.

6. After checked, open the connector CNE702.

Playback Level Adjustment

Procedure :

Mode : playback

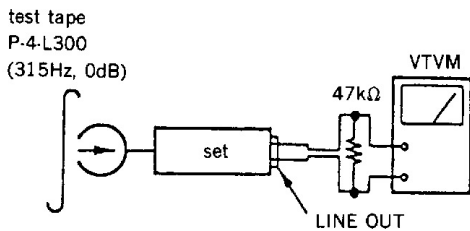

Adjust RV121 (L-CH) and RV221 (R-CH) so that the reading on VTVM meets the adjustment limits below.

Adjustment Limits :

LINE OUT level : -8.2 to -7.2dB (0.301 to 0.338V)

Level difference between channels : within 0.5dB

Confirm that the LINE OUT level does not change even if Playback and Stop operation is repeated several times.

Adjutment Location : MAIN board

Bias Consumption Current Adjustment

Procedure :

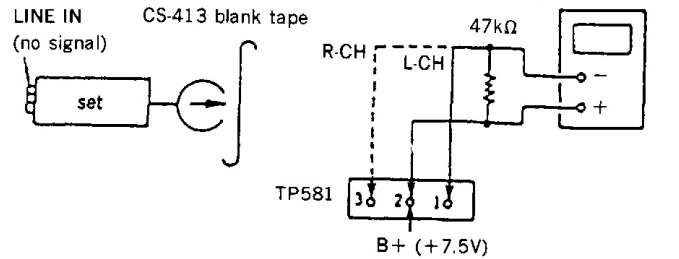

1. Set RV181 (L-CH) and RV281 (R-CH) to mechanical center and turn the set recording mode.
2. Connect digital voltmeter as shown by the following table.
3. Adjust the following transformers for the minimum readings on the digital voltmeter

	Measurement Point	Adjustment Part	Value
L-CH	① and ②, TP581	T181	less than 200mV
R-CH	③ and ②, TP581	T281	

Adjustment Location : MAIN board

Record Bias Adjustment

Setting :

REC LEVEL control : Standard Record

Procedure :

1. Short the connector CNE702 (pins ① and ②). (test mode)
2. Mode : record

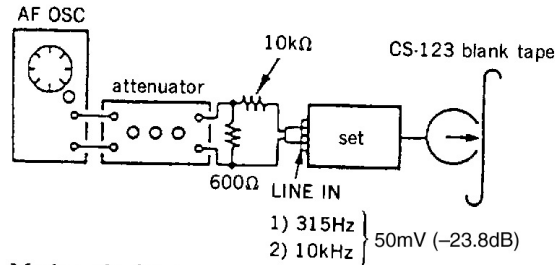

3. Mode : playback

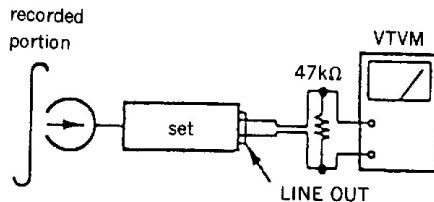

4. Playback the signal recorded in step 1.
5. Confirm that the 10kHz playback output is $0 \pm 0.5\text{dB}$: (TC-K715S/K815S) or $0 \pm 0.3\text{dB}$: (TC-K717ES) relative to the 315Hz output. If necessary, adjust RV181 (L-CH) and RV281 (R-CH) for repeat the steps given above.
6. After adjustment, open the connector CNE702.

Adjustment Location : MAIN board

Record Level Adjustment

Setting :

REC LEVEL control : Standard Record

Procedure :

1. Short the connector CNE702 (pins ① and ②). (test mode)
2. Mode : record

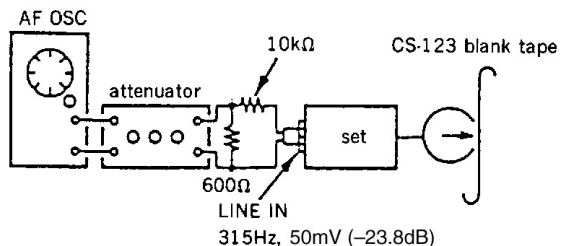

3. Mode : playback

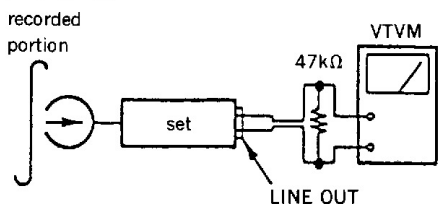

4. Playback the signal recorded in step 1.
5. Confirm that the signal level is within the adjustment limits below. If necessary, adjust RV141 (L-CH) and RV241 (R-CH) repeat the steps given above.
6. After adjustment, open the connector CNE702.

Adjustment Limits : -24.3 to -23.3dB (47.2 to 53mV)

Adjustment Location : MAIN board

Erase Current Adjustment (TC-K717ES/K815S)

1. Mode : record

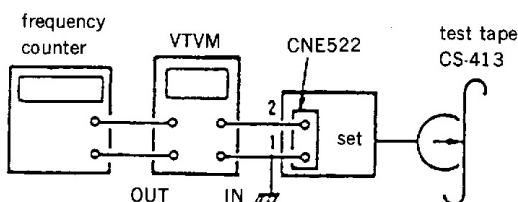

2. Adjust RV504 so that the reading on VTVM is 110mV (erase current=110mA.)
3. And then confirm that the reading on the frequency counter is 160kHz.

Adjustment Limits :

Erase current : 105 to 110mA
 Frequency : 160±6kHz

Adjustment Location : MAIN board

Record EQ (IV) Adjustment

Setting :

REC LEVEL control : Standard Record

Procedure :

1. Short the connector CNE702 (pins ① and ②). (test mode)
2. Mode : record

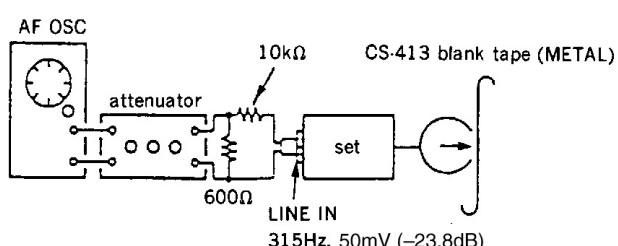

3. Mode : playback

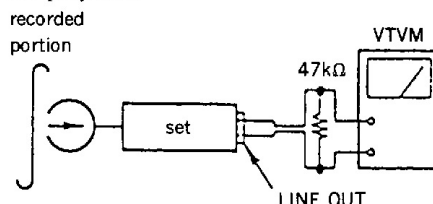

4. Playback the signal recorded in step 1.
5. Adjust RV142 (L-CH) or RV242 (R-CH) so that the reading on VTVM meets the within 1dB for difference between L-CH and R-CH.
6. Adjust RV508 so that the R-CH meet the specification.
7. After adjustment, open the connector CNE702.

Adjustment Limits :

10kHz level difference against 315Hz reference.
 0±0.3dB : (TC-K717ES)
 0±0.5dB : (TC-K715S/K815S)

Adjustment Location : MAIN board

Adjustment Location :

【 MAIN BOARD 】 (COMPONENT SIDE)

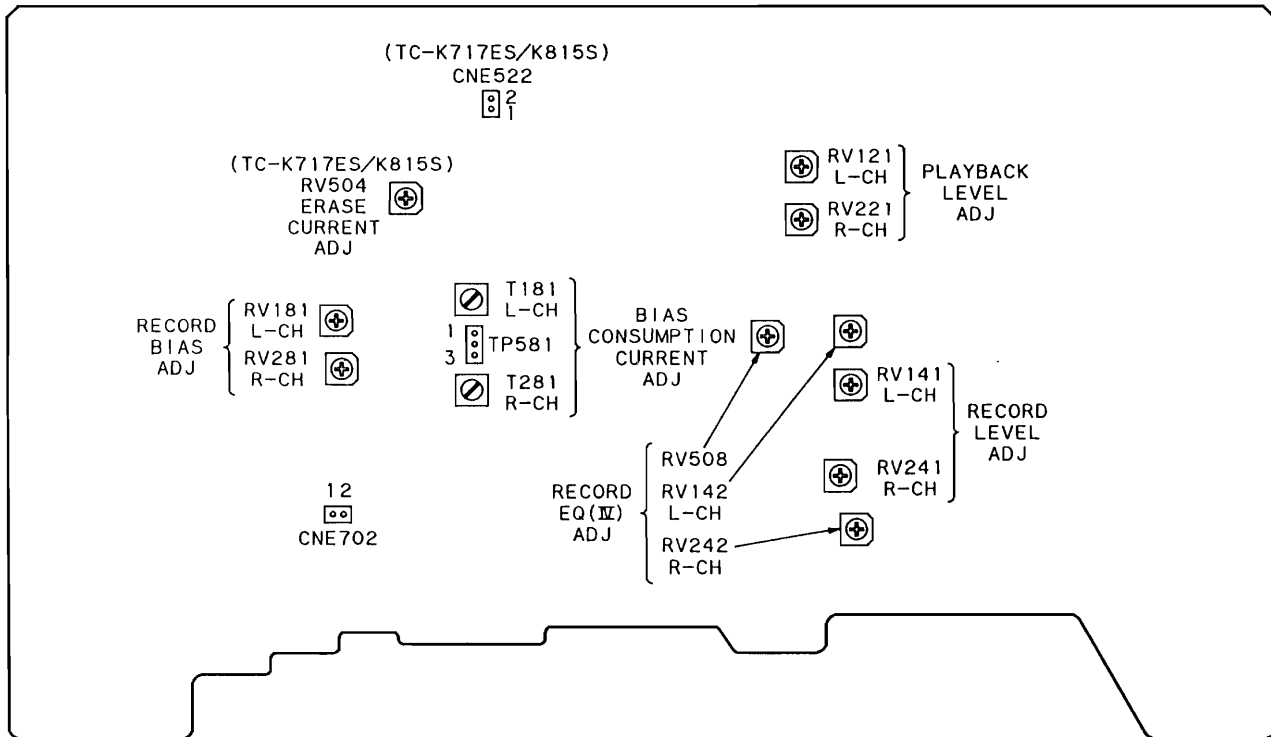

SECTION 5
DIAGRAMS

5-1. BLOCK DIAGRAM

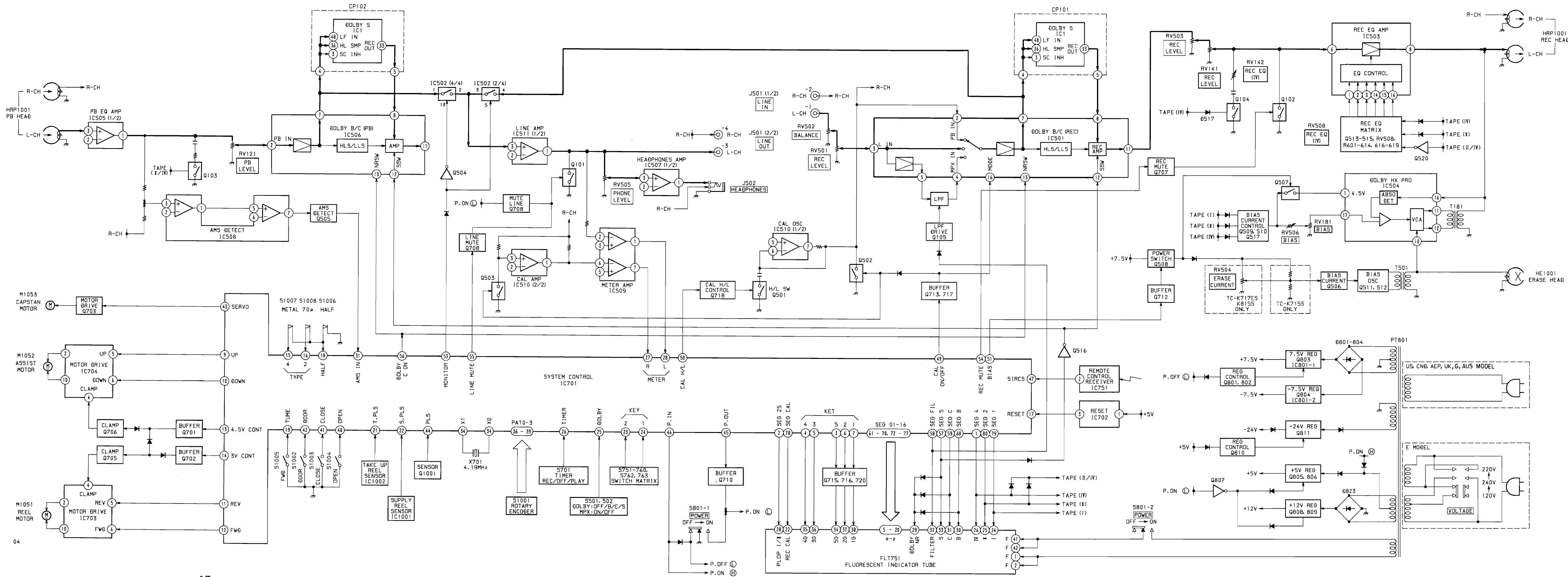

5-2. CIRCUIT BOARDS LOCATION

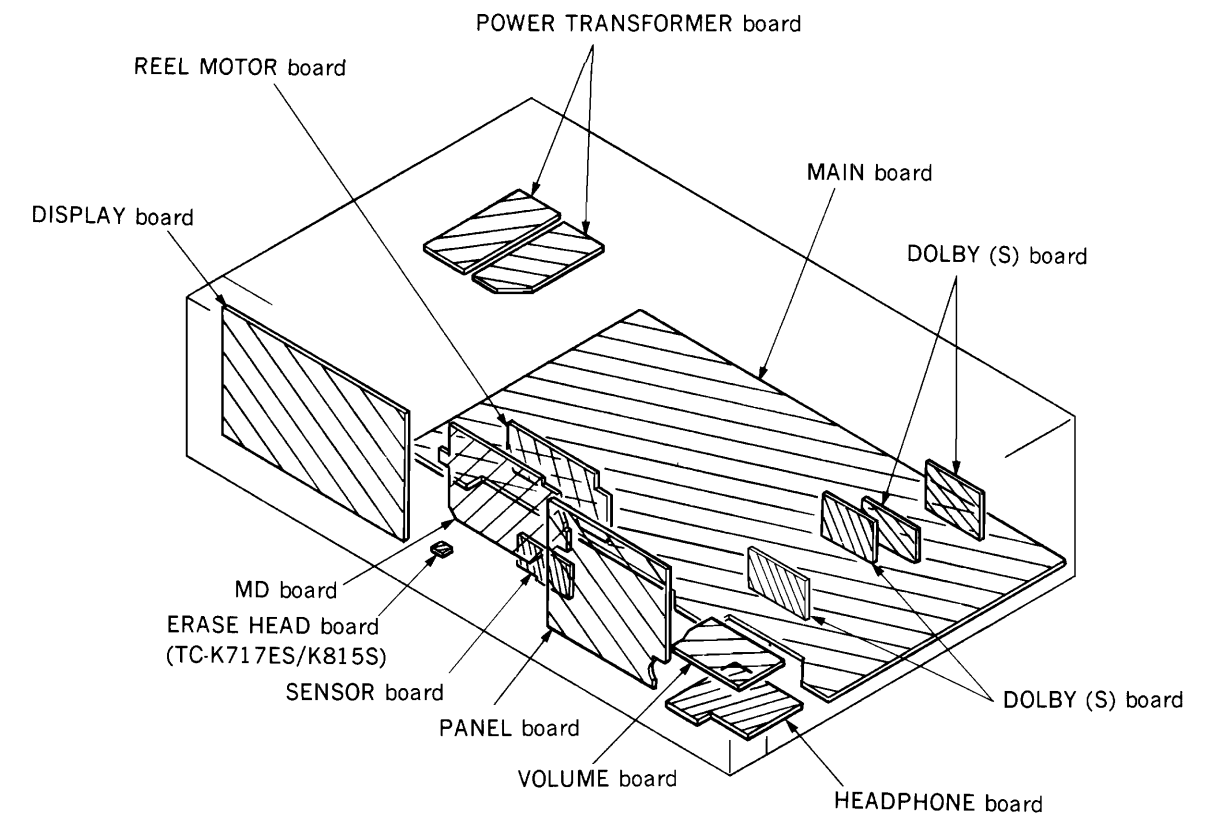

• Semiconductor Location

Ref. No.	Location	Ref. No.	Location
D101	B-7	IC701	H-17
D102	B-7	IC702	G-14
D201	C-7	IC703	E-17
D202	C-7	IC704	E-19
D502	E-12	IC751	G-26
D503	E-12	IC801	C-18
D504	G-8	IC1001	F-3
D505	G-8	IC1002	F-4
D507	D-13		
D508	D-13	Q101	C-8
D509	C-16	Q102	F-12
D510	F-13	Q103	C-12
D511	F-13	Q104	F-11
D512	C-10	Q105	E-9
D513	H-11	Q201	D-7
D514	H-11	Q202	G-12
D515	G-8	Q203	D-12
D516	F-13	Q204	F-11
D517	E-12	Q205	G-9
D518	D-10	Q501	G-7
D519	D-9	Q502	G-7
D520	C-9	Q503	F-8
D521	C-9	Q504	E-8
D531	H-12	Q505	C-10
D703	F-17	Q506	D-15
D704	F-17	Q507	D-16
D705	F-18	Q508	D-15
D707	H-14	Q509	D-16
D708	G-14	Q510	D-16
D709	G-14	Q511	D-15
D751	G-22	Q512	D-15
D752	G-22	Q513	F-13
D753	G-22	Q514	F-13
D801	D-18	Q515	F-13
D802	D-18	Q516	E-10
D803	D-18	Q517	D-16
D804	D-18	Q520	D-13
D805	C-17	Q701	F-17
D806	B-17	Q702	F-17
D807	D-19	Q703	G-16
D812	E-18	Q705	F-18
D813	E-18	Q706	F-19
D814	E-17	Q707	H-13
D815	E-19	Q708	H-14
D816	C-19	Q710	H-17
D817	B-19	Q712	D-16
D818	E-18	Q713	H-12
D819	D-17	Q714	H-14
D820	E-17	Q715	G-19
D822	F-19	Q716	G-19
D823	C-18	Q717	H-12
D824	D-17	Q718	H-13
D1051	C-4	Q720	G-19
		Q801	B-18
IC501	F-10	Q802	B-18
IC502	D-9	Q803	B-17
IC503	G-12	Q804	B-17
IC504	E-15	Q805	E-17
IC505	D-13	Q806	E-17
IC506	D-10	Q807	C-19
IC507	H-28	Q808	B-18
IC508	B-11	Q809	C-19
IC509	C-7	Q810	D-17
IC510	F-7	Q811	D-17
IC511	D-8	Q1001	H-5

Note:
 ○ : parts extracted from the component side.
 ▨ : Pattern on the side which is seen.
 • : Abbreviations
 CND : Canadian model
 G : German model
 AUS : Australian model

5-3. PRINTED WIRING BOARDS—MAIN SECTION— • Refer to page 37 for Semiconductor Lead Layouts.

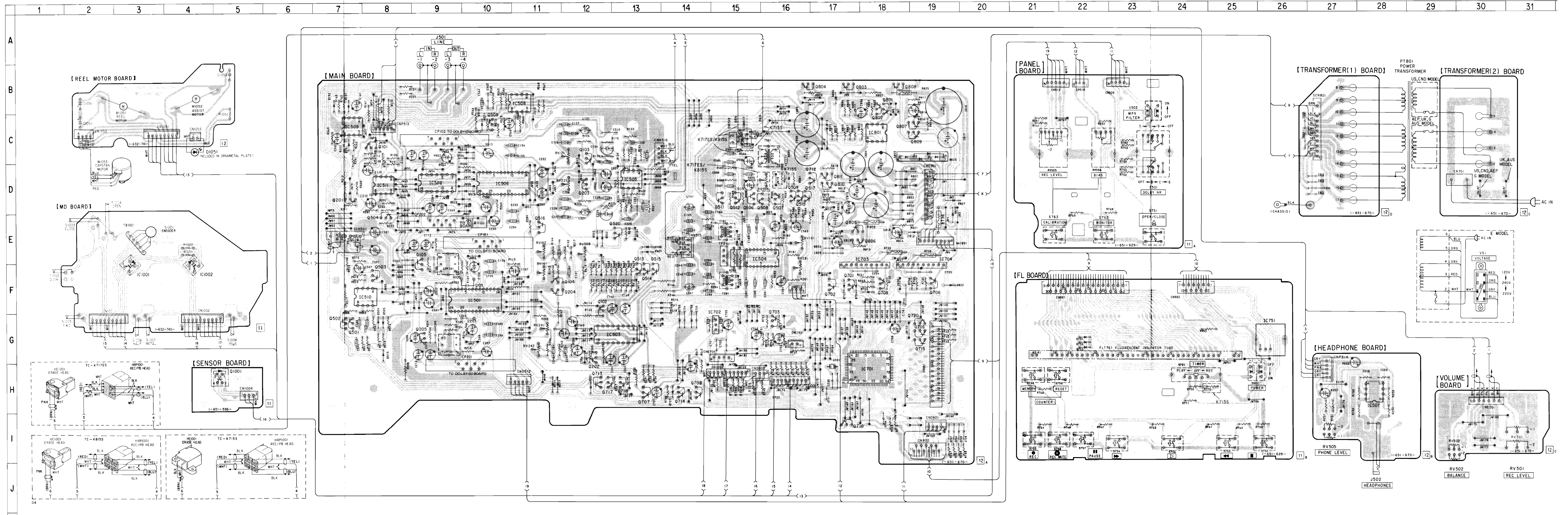

5-5. SCHEMATIC DIAGRAM—SYSTEM CONTROL SECTION—

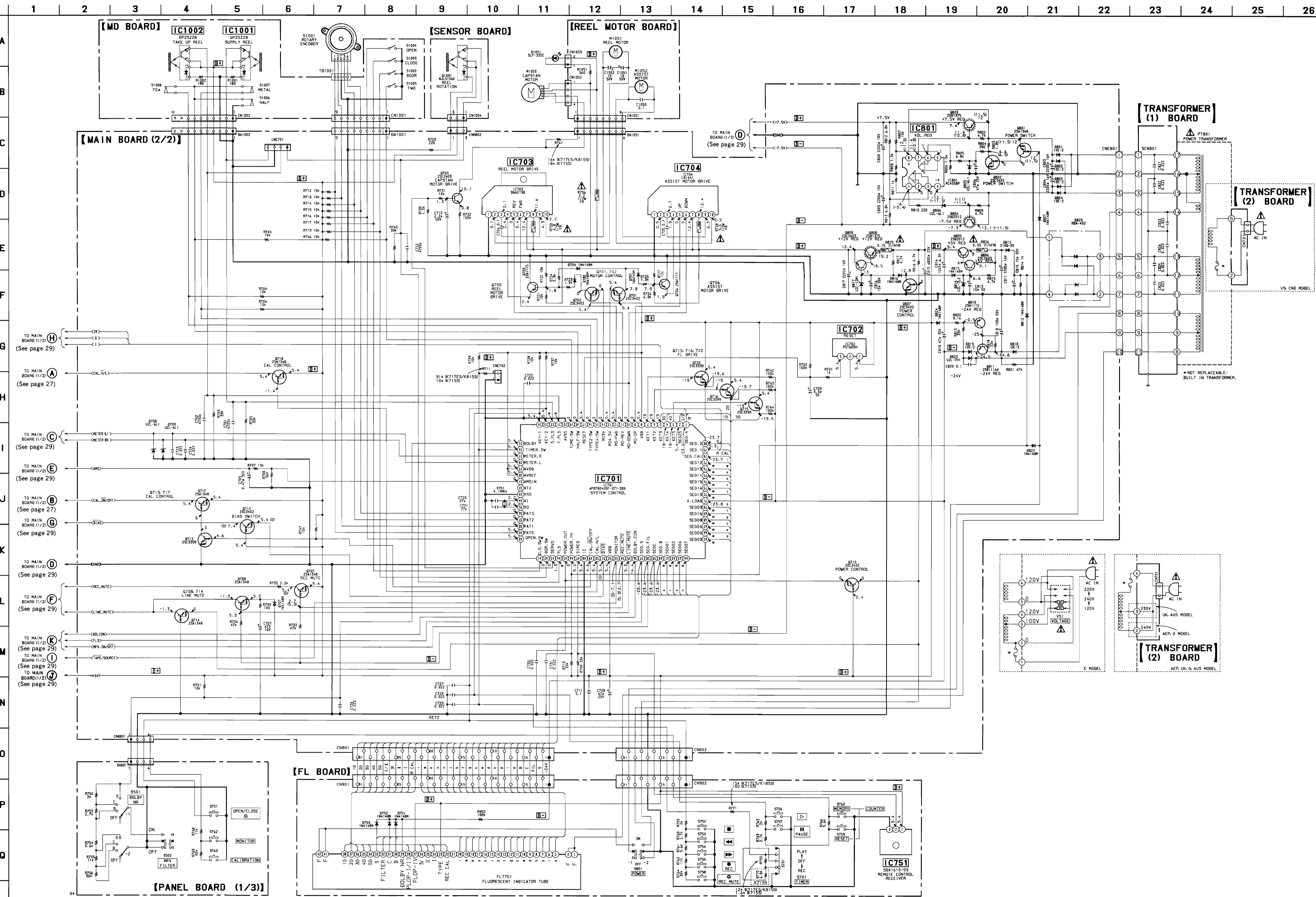

• IC Block Diagrams
 IC703 BA6219B
 IC704 LB1641

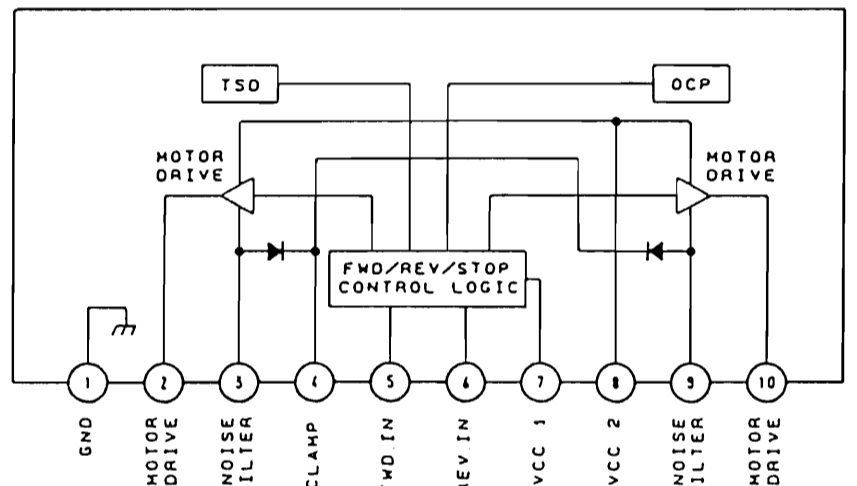

Note:

- All capacitors are in μF unless otherwise noted. μF : μF 50WV or less are not indicated except for electrolytics and tantalums.
- All resistors are in Ω and 1/4 W or less unless otherwise specified.

Note:

- The components identified by mark Δ or dotted line with mark Δ are critical for safety. Replace only with part number specified.
- The composants identifiés par une marque Δ sont critiques pour la sécurité. Ne les remplacer que par une pièce portant le numéro spécifié.

Note:

- $\text{---}/\text{---}$: fusible resistor.
- B+ : B+ Line
- B- : B- Line
- Voltage is dc with respect to ground under no-signal conditions.
- no mark: PB
- (): REC
- Voltages are taken with a VOM (Input Impedance 10M Ω). Voltage variations may be noted due to normal production tolerances.
- Abbreviations
 CND: Canadian model
 G: German model
 AUS: Australian model

5-6. SCHEMATIC DIAGRAM—DOLBY S SECTION—

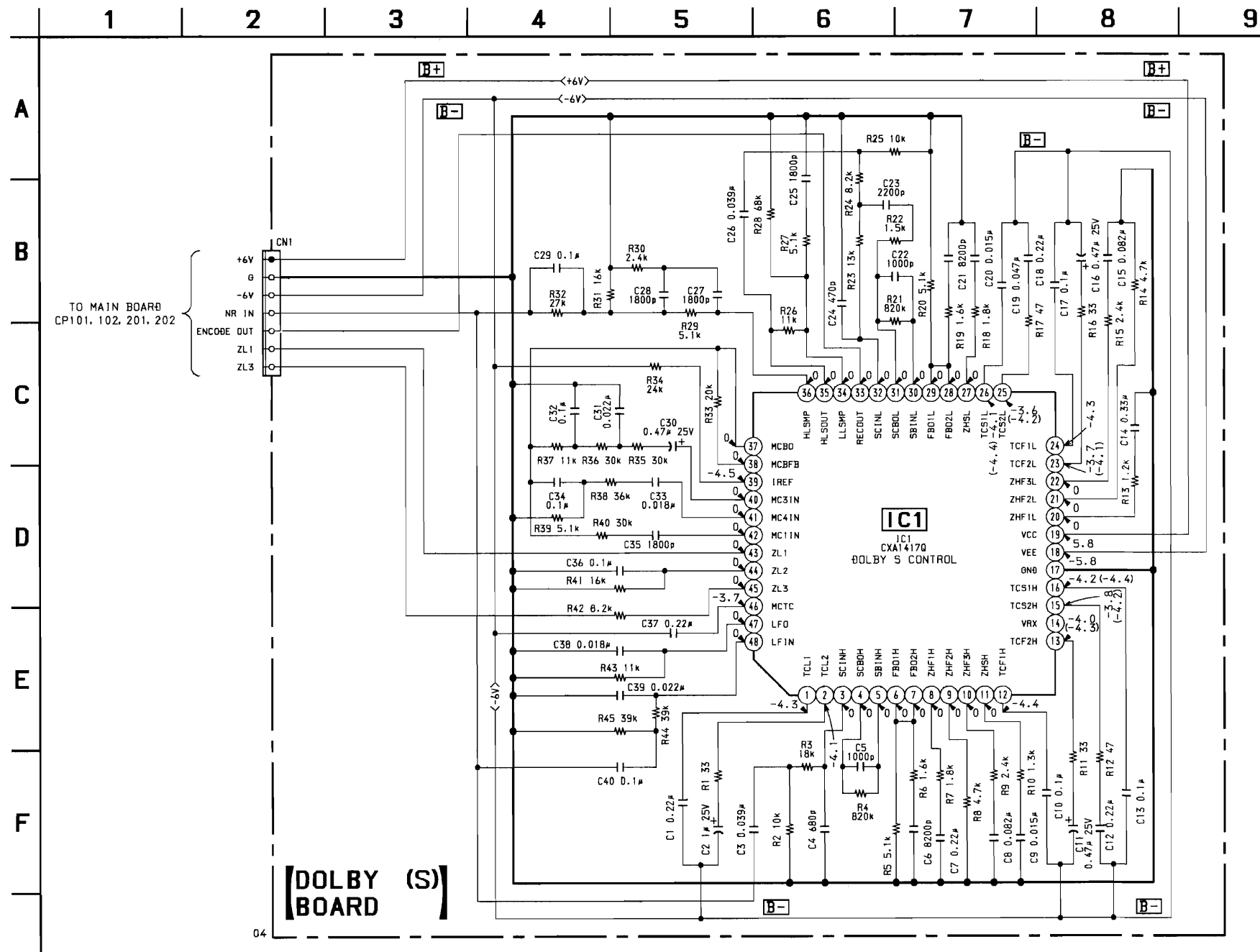

Note on Schematic Diagram:

- All capacitors are in μF unless otherwise noted. $\text{pF} : \mu\mu\text{F}$ 50WV or less are not indicated except for electrolytics and tantalums.
- All resistors are in Ω and 1/4 W or less unless otherwise specified.
- $\boxed{B+}$: B+ Line
- $\boxed{B-}$: B- Line
- Voltage is dc with respect to ground under no-signal conditions.
- no mark: PB
- (): REC
- Voltages are taken with a VOM (Input Impedance 10M Ω). Voltage variations may be noted due to normal production tolerances.

5-7. PRINTED WIRING BOARD—DOLBY S SECTION—

• Refer to page 37 for Semiconductor Lead Layouts.

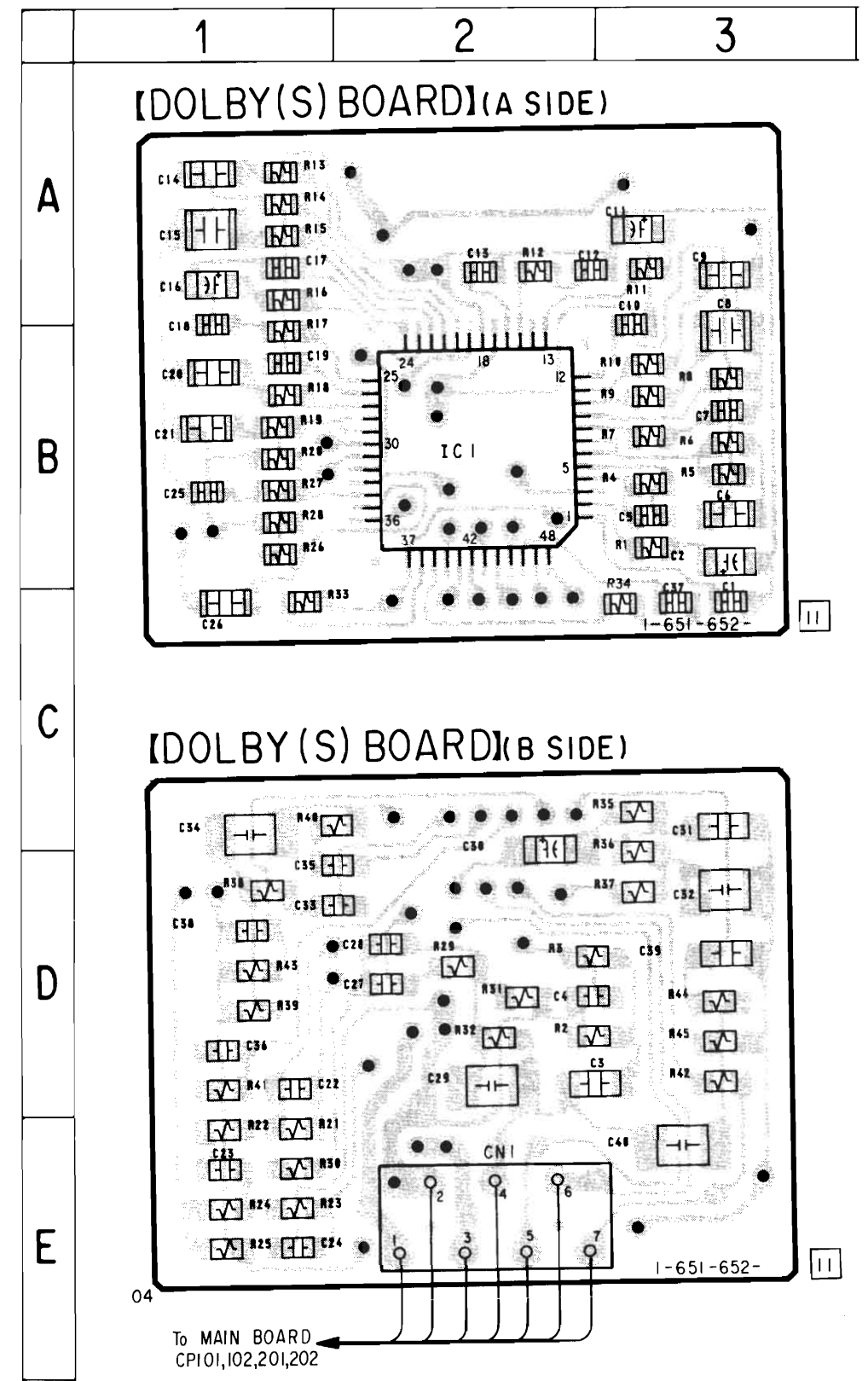

Note on Printed Wiring Board:

- \circ : parts extracted from the component side.
- \bullet : Through hole.
- \square : Pattern on the side which is seen. (The other layer's patterns are not indicated.)

SECTION 6 EXPLODED VIEWS

5-8. SEMICONDUCTOR LEAD LAYOUTS

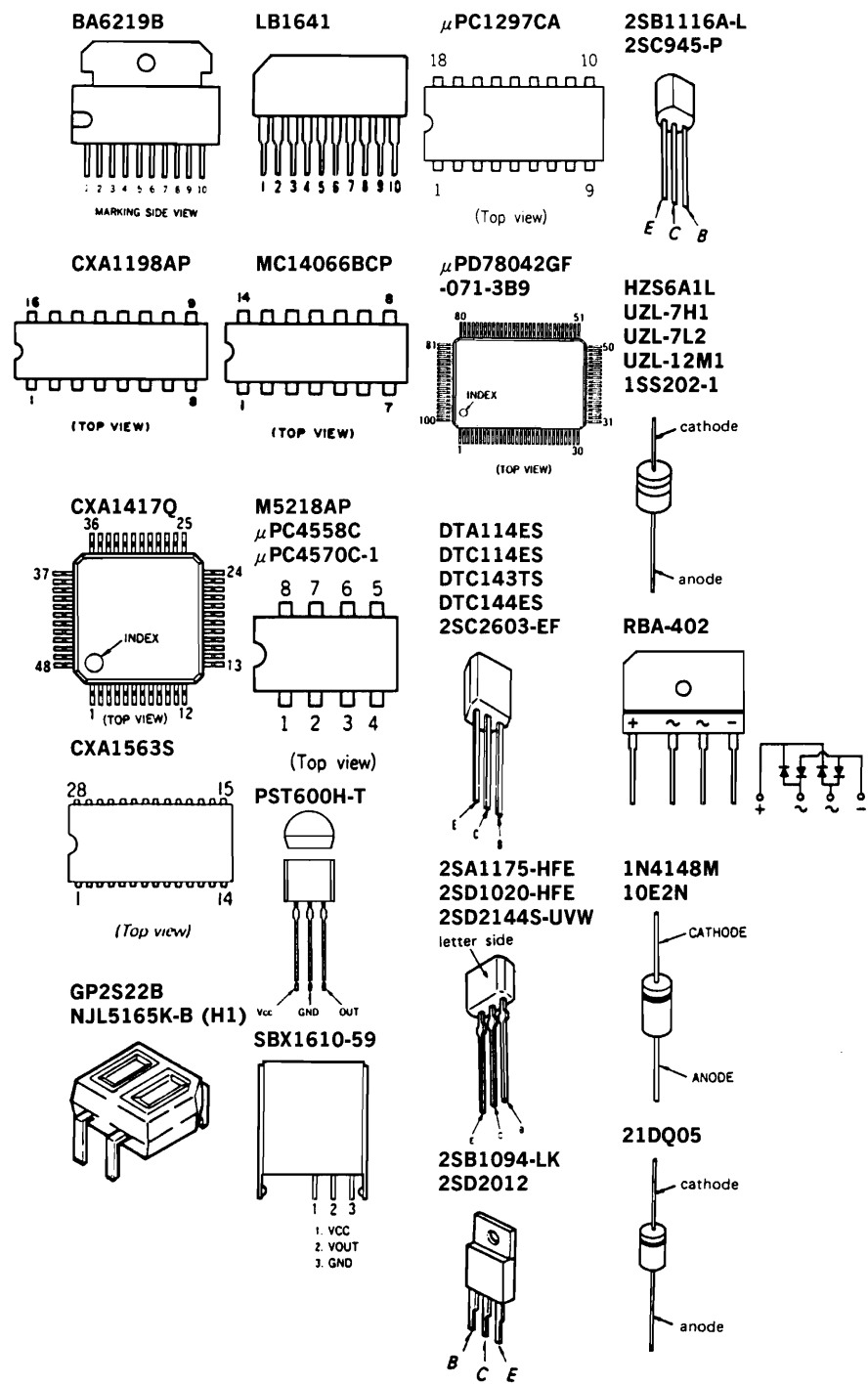

NOTE:

- The mechanical parts with no reference number in the exploded views are not supplied.
- Items marked "*" are not stocked since they are seldom required for routine service. Some delay should be anticipated when ordering these items.
- -XX and -X mean standardized parts, so they may have some difference from the original one.

- Color Indication of Appearance Parts
Example :
KNOB, BALANCE (WHITE)... (RED)
↑ ↑
Parts Color Cabinet's Color
- Hardware (# mark) list and accessories and packing materials are given in the last of this parts list.
- Abbreviations
AUS : Australian model
G : German model

The components identified by mark Δ or dotted line with mark Δ are critical for safety. Replace only with part number specified.

Les composants identifiés par une marque Δ sont critiques pour la sécurité. Ne les remplacer que par une pièce portant le numéro spécifié.

6-1. FRONT PANEL SECTION

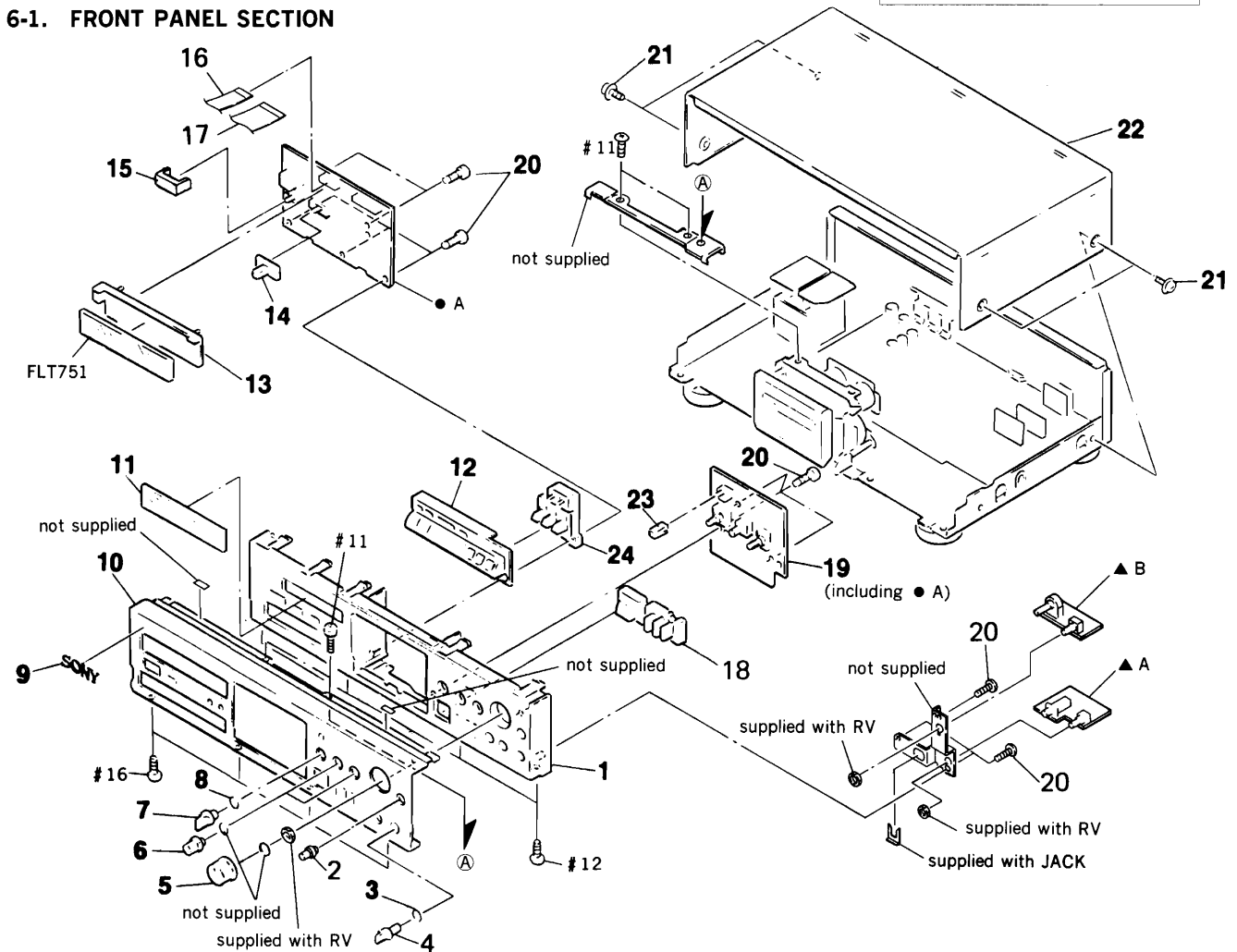

Ref. No.	Part No.	Description	Remark
1	3-386-253-01	PANEL (BASE)	
2	3-370-003-01	KNOB (BAL)	
3	3-356-957-01	SPRING	
4	3-350-495-01	KNOB (VOL)	
5	3-367-438-11	KNOB (REC)	
6	X-3365-387-1	KNOB (BAL) ASSY (B)	
7	4-908-097-21	KNOB	
8	3-350-440-01	SPRING	
9	4-942-568-01	EMBLEM (NO. 5), SONY	
10	3-910-630-01	PANEL, FRONT (US, Canadian)	
10	3-910-630-11	PANEL, FRONT (E)	
10	3-910-630-21	PANEL, FRONT (K717ES:AUS)	
10	3-910-630-31	PANEL, FRONT (K815S)	
10	3-910-630-41	PANEL, FRONT (K715S)	
11	3-386-243-11	WINDOW (M)	

Ref. No.	Part No.	Description	Remark
12	3-386-247-01	BUTTON (FW)	
* 13	3-386-245-01	HOLDER (FL)	
14	4-922-518-01	KNOB (TIMER)	
15	3-354-932-01	BUTTON (POWER)	
16	1-534-517-00	WIRE, FLAT TYPE (11 CORE)	
17	1-765-149-11	WIRE (FLAT TYPE) (31 CORE)	
18	3-386-249-01	BUTTON (E.J)	
* 19	A-2007-161-A	PANEL BOARD, COMPLETE (K717ES/K815S)	
* 19	A-2007-231-A	PANEL BOARD, COMPLETE (K715S)	
20	4-951-620-01	SCREW (2.6X8), +BVT	
21	3-704-366-01	SCREW (CASE) (M3X8)	
22	3-332-578-61	CASE	
23	3-380-952-01	BUTTON	
24	3-386-248-01	BUTTON (RE)	
FLT751	1-517-163-11	INDICATOR TUBE, FLUORESCENT	

6-2. CHASSIS SECTION

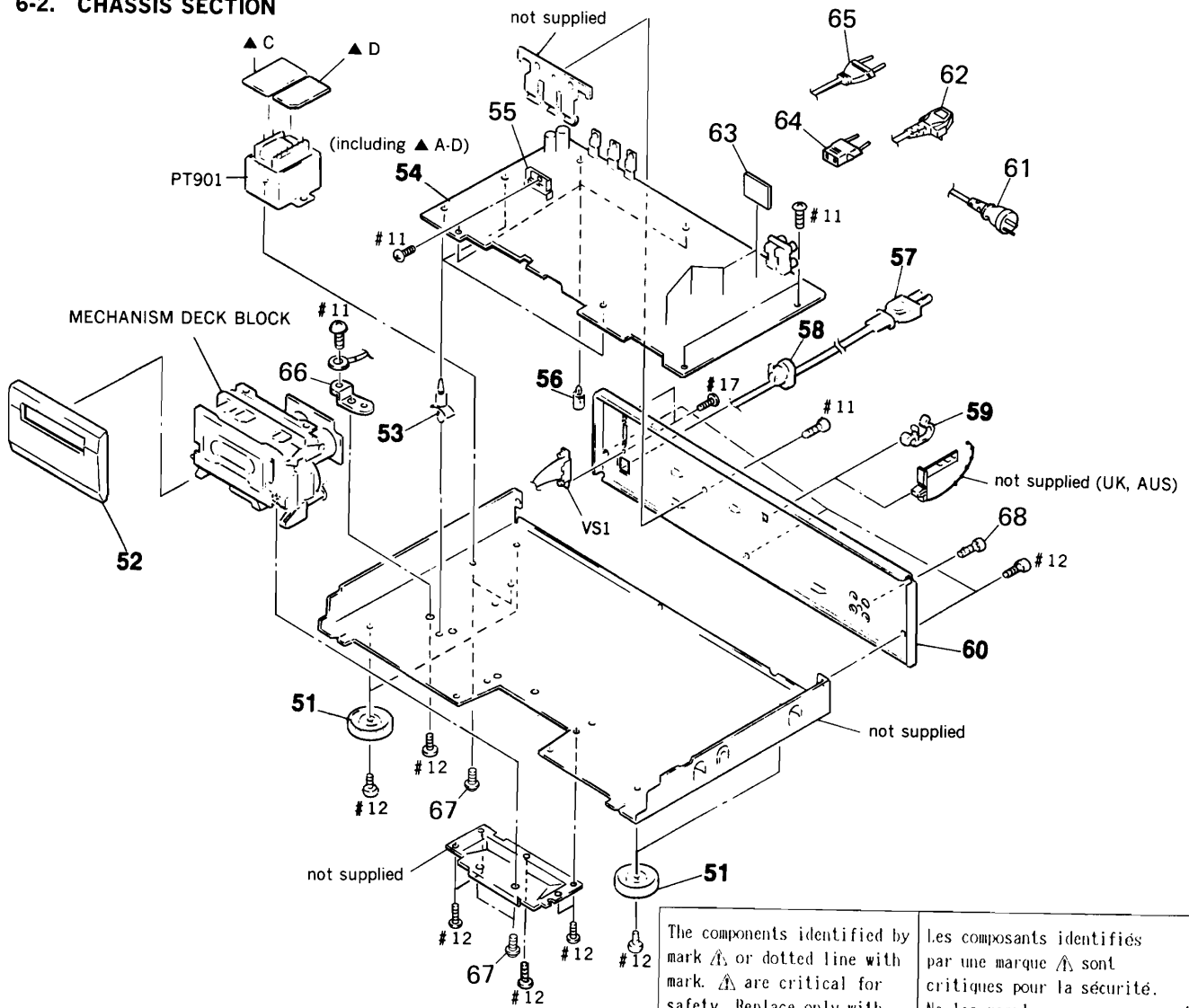

The components identified by mark ▲ or dotted line with mark ▲ are critical for safety. Replace only with part number specified.

Les composants identifiés par une marque ▲ sont critiques pour la sécurité. Ne les remplacer que par une pièce portant le numéro spécifié.

Ref. No.	Part No.	Description	Remark
	51	4-943-148-42 FOOT (F58175SW)	
	52	X-3367-895-1 LID ASSY, CASSETTE (US, Canadian)	
	52	X-3367-896-1 LID ASSY, CASSETTE (K717ES:E, AUS)	
	52	X-3367-897-1 LID ASSY, CASSETTE (K815S)	
	52	X-3367-898-1 LID ASSY, CASSETTE (K715S)	
*	53	3-346-265-11 HOLDER, PC BOARD	
*	54	A-2007-151-A MAIN BOARD, COMPLETE (US, Canadian)	
*	54	A-2007-152-A MAIN BOARD, COMPLETE (E)	
*	54	A-2007-153-A MAIN BOARD, COMPLETE (K717ES:AUS)	
*	54	A-2007-154-A MAIN BOARD, COMPLETE (K815S)	
*	54	A-2007-156-A MAIN BOARD, COMPLETE (K715S:AEP, G)	
*	54	A-2007-157-A MAIN BOARD, COMPLETE (K715S:UK, AUS)	
*	55	3-356-925-01 HEAT SINK	
*	56	3-669-610-00 SPACER	
▲	57	1-551-188-XX CORD, POWER (E)	
▲	57	1-558-945-21 CORD, POWER (POLAR. SPT-1) (US, Canadian)	
*	58	3-703-244-00 BUSHING (2104), CORD (AEP, UK, G, AUS)	
*	58	3-703-571-11 BUSHING (S) (4516), CORD (US, Canadian, E)	
*	59	4-949-235-01 HOOK (EXCEPT UK, AUS)	

Ref. No.	Part No.	Description	Remark
*	60	3-910-631-01 PANEL, BACK (US, Canadian)	
*	60	3-910-631-11 PANEL, BACK (E)	
*	60	3-910-631-21 PANEL, BACK (K717ES:AUS)	
*	60	3-910-631-31 PANEL, BACK (K815S)	
*	60	3-910-632-01 PANEL, BACK (K715S:AEP, G)	
*	60	3-910-632-11 PANEL, BACK (K715S:UK, AUS)	
▲	61	1-696-845-11 CORD, POWER (AUS)	
▲	62	1-696-586-11 CORD, POWER (UK)	
*	63	A-2007-173-A DOLBY (S) BOARD, COMPLETE	
▲	64	1-569-007-11 ADAPTOR, CONVERSION 2P (E)	
▲	65	1-575-651-21 CORD, POWER (AEP, G)	
*	66	3-332-563-01 BRACKET (P)	
	67	4-886-821-11 SCREW, M3 CASE	
	68	3-704-515-01 SCREW (BV/RING)	
▲	PT901	1-423-475-11 TRANSFORMER, POWER (US, Canadian)	
▲	PT901	1-423-476-11 TRANSFORMER, POWER (AEP, UK, G, AUS)	
▲	PT901	1-423-533-11 TRANSFORMER, POWER (E)	
▲	VS1	1-692-155-11 SELECTOR, POWER VOLTAGE (VOLTAGE) (E)	

**6-3. MECHANISM DECK SECTION 1
(TCM-200V18 : TC-K715S)**

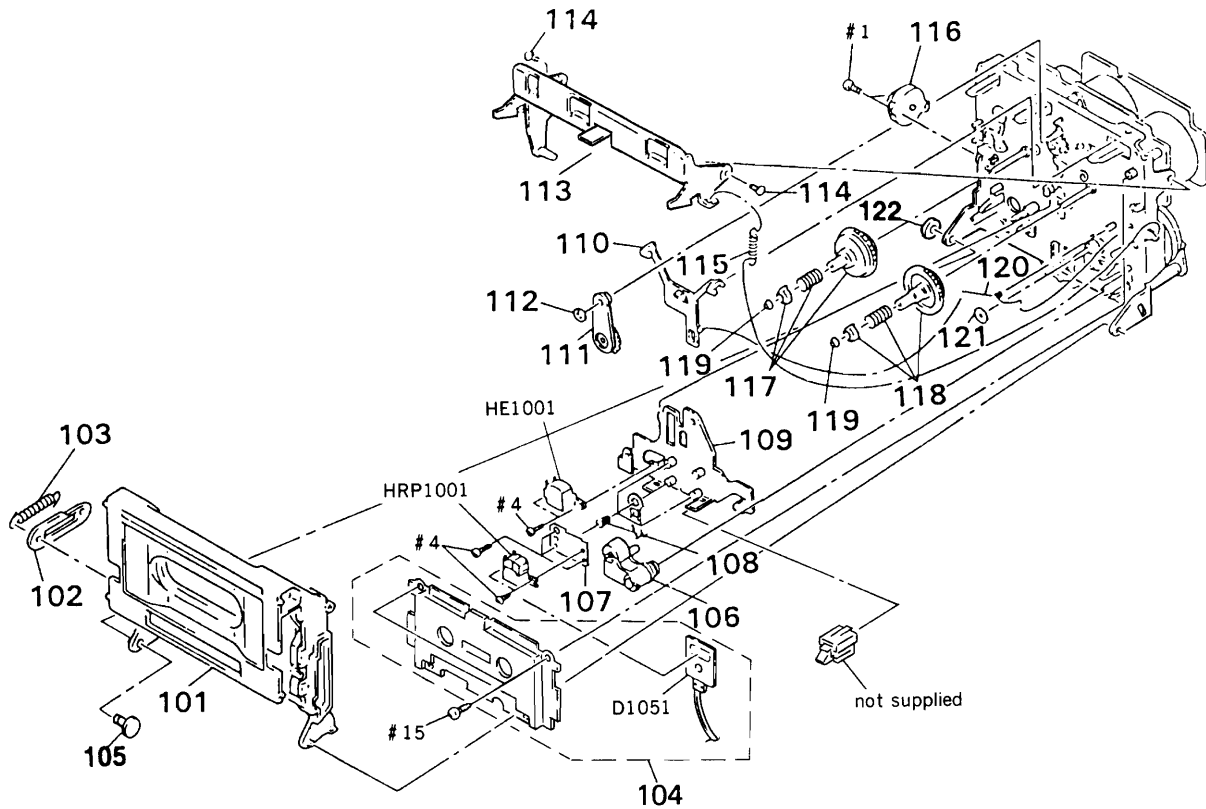

Ref. No.	Part No.	Description	Remark	Ref. No.	Part No.	Description	Remark
101	X-3368-527-1	HOLDER (CD-CS) ASSY, CASSETTE		114	3-356-601-11	SCREW, STEP	
* 102	3-356-717-01	LEVER (JOINT)		115	3-356-625-01	SPRING, TENSION	
103	3-356-626-01	SPRING, TENSION		116	3-712-786-01	DAMPER, OIL	
104	X-3356-613-1	PLATE ASSY, ORNAMENTAL		117	X-3356-628-1	GEAR (S) ASSY	
105	3-378-341-01	SHAFT (L) (CASSETTE HOLDER)		118	X-3356-627-1	GEAR (T) ASSY	
106	X-3356-649-1	LEVER (PINCH LEVER T) ASSY		119	3-362-308-01	CAP (REEL)	
* 107	3-356-742-01	BRACKET (GUIDE R)		120	3-356-619-01	SPRING (B), TORSION	
108	3-356-659-01	SPRING (RPH), COMPRESSION		121	3-356-713-01	WASHER	
109	X-3356-648-1	SLIDER (HEAD CHASSIS V2) ASSY		122	3-558-708-21	WASHER, STOPPER	
110	3-356-614-01	SLIDER (BRAKE)		D1051	8-719-980-85	DIODE SLF325C	
111	X-3356-641-1	LEVER (FR2) ASSY		HE1001	1-543-673-11	HEAD, MAGNETIC (ERASE)	
112	3-669-465-11	WASHER (1.5), STOPPER		HRP1001	1-543-733-11	HEAD, MAGNETIC (REC/PB)	
* 113	X-3356-608-1	LEVER (LIFTER) ASSY					

**6-4. MECHANISM DECK SECTION 2
(TCM-200V18: TC-K715S)**

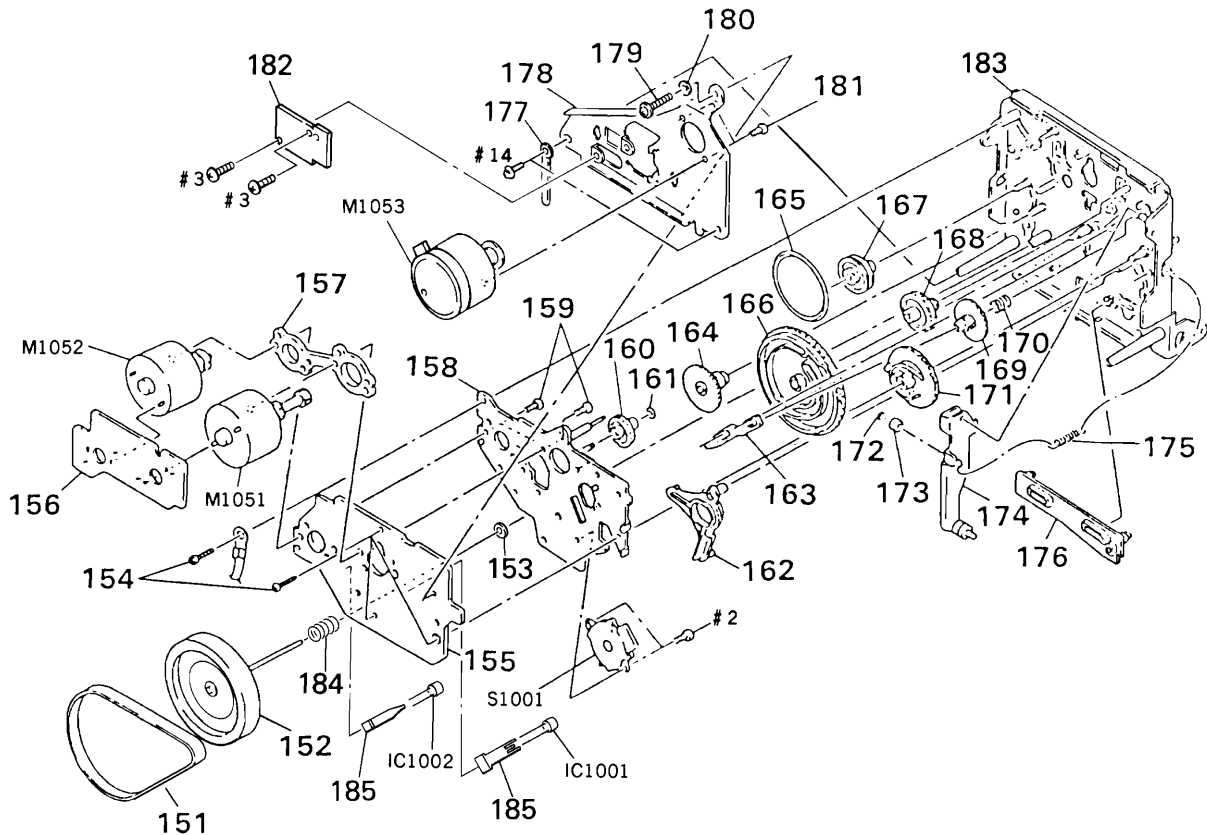

Ref. No.	Part No.	Description	Remark	Ref. No.	Part No.	Description	Remark
151	3-356-744-01	BELT (CAPSTAN V)		172	3-558-708-11	WASHER, STOPPER	
152	X-3368-012-1	FLYWHEEL (V) ASSY		173	3-356-630-01	ROLLER (LOADING)	
153	3-911-245-01	WASHER (CAPSTAN)		* 174	X-3356-606-1	LEVER (LOADING) ASSY	
154	3-355-801-01	SCREW (BTP 2X18)		175	3-356-624-01	SPRING, TENSION	
* 155	1-632-740-11	MD BOARD		176	3-356-653-01	SLIDER (PAUSE)	
* 156	1-632-741-11	REEL MOTOR BOARD		177	3-703-150-11	STOPPER, WIRING	
* 157	3-356-628-01	SPACER (MOTOR)		178	X-3368-011-1	BRACKET ASSY	
* 158	X-3356-602-1	BRACKET (MOTOR R) ASSY		179	3-356-707-01	SCREW (+PTPWH 2X25)	
159	3-363-804-01	SCREW (+P 2.6X6.5)		* 180	3-356-718-01	SPACER (THRUST RETAINER R)	
160	3-356-702-01	GEAR (COMMUNICATION B)		181	4-885-599-00	SCREW, FITTING, REINFORCEMENT	
161	3-669-465-00	WASHER (1.5), STOPPER		* 182	1-651-596-11	SENSOR BOARD	
162	3-356-613-01	LEVER (MODE)		* 183	X-3368-013-1	CHASSIS (V18) COMPLETE ASSY, MECHANICAL	
163	3-356-617-01	LEVER (SELECTION)		184	3-911-236-01	SPRING, COMPRESSION	
164	3-356-606-01	GEAR (MODE)		185	3-356-631-01	HOLDER (SENSOR)	
165	3-356-603-01	BELT (MODE)		IC1001	8-749-920-97	PHOTO SENSOR GP2S22B	
166	3-356-747-01	GEAR (MODE CAM C)		IC1002	8-749-920-97	PHOTO SENSOR GP2S22B	
167	3-356-607-01	PULLEY (MODE)		M1051	X-3356-638-1	MOTOR (REEL R) ASSY	
168	3-356-703-01	GEAR (COMMUNICATION C)		M1052	X-3356-604-1	MOTOR (ASSIST) ASSY	
169	3-356-609-01	GEAR (LOADING)		M1053	X-3368-029-1	MOTOR (CAPSTAN V18) ASSY	
170	3-356-605-01	SPRING, COMPRESSION		S1001	1-466-238-11	ENCODER, ROTARY	
171	3-356-616-01	GEAR (LOADING CAM)					

6-5. MECHANISM DECK SECTION 3
(TCM-200V19 : TC-K717ES)
(TCM-200V20 : TC-K815S)

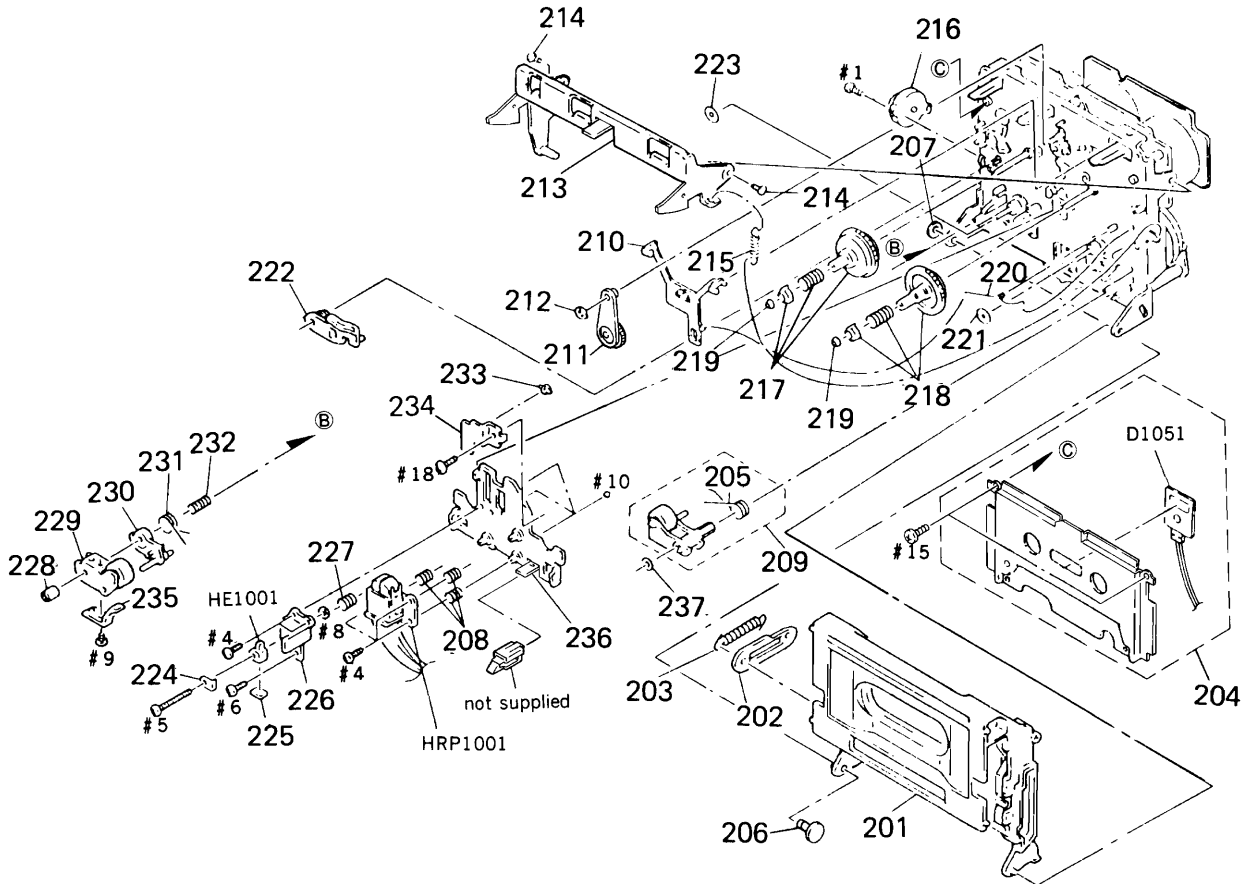

Ref. No.	Part No.	Description	Remark
201	X-3368-527-1	HOLDER (CD-CS) ASSY, CASSETTE	
* 202	3-356-717-01	LEVER (JOINT)	
203	3-356-626-01	SPRING, TENSION	
204	X-3356-613-1	PLATE ASSY, ORNAMENTAL	
205	3-356-672-01	SPRING (PINCH LEVER T), TORSION	
206	3-378-341-01	SHAFT (L) (CASSETTE HOLDER)	
207	3-558-708-21	WASHER, STOPPER	
208	3-356-659-01	SPRING (RPH), COMPRESSION	
209	X-3356-620-1	LEVER (PINCH LEVER T) ASSY	
210	3-356-614-01	SLIDER (BRAKE)	
211	X-3356-641-1	LEVER (FR2) ASSY	
212	3-669-465-11	WASHER (1.5), STOPPER	
* 213	X-3356-608-1	LEVER (LIFTER) ASSY	
214	3-356-601-11	SCREW, STEP	
215	3-356-625-01	SPRING, TENSION	
216	3-712-786-01	DAMPER, OIL	
217	X-3356-629-1	GEAR (S) ASSY	
218	X-3356-627-1	GEAR (T) ASSY	
219	3-362-308-01	CAP (REEL)	
220	3-356-619-01	SPRING (B), TORSION	
221	3-332-763-01	RING, OIL RESERVOIR	

Ref. No.	Part No.	Description	Remark
222	X-3356-623-1	LEVER (BT) ASSY	
223	3-356-713-01	WASHER	
224	3-318-433-01	SPRING	
* 225	1-608-268-00	ERASE HEAD BOARD	
* 226	3-576-977-00	BRACKET, ERASE HEAD	
227	3-564-121-00	SPRING, COMPRESSION	
228	3-356-652-01	NUT (PINCH LEVER S)	
229	X-3356-621-1	LEVER (PINCH LEVER S) ASSY	
230	3-356-660-01	LEVER (PS)	
231	3-356-661-01	SPRING (PINCH LEVER S), TORSION	
232	3-356-657-01	SPRING (PS), COMPRESSION	
233	3-367-775-01	ROLLER (HEAD CHASSIS)	
234	3-356-656-11	SPRING (HEAD PC BOARD), LEAF	
235	3-389-445-01	GUIDE (SL), TAPE	
236	X-3362-861-1	SLIDER (HEAD CHASSIS V4) ASSY	
237	3-669-596-01	WASHER (2.3), STOPPER	
D1051	8-719-980-85	DIODE SLF325C	
HE1001	1-543-836-11	HEAD, MAGNETIC (ERASE)	
HRP1001	1-543-834-11	HEAD, MAGNETIC (REC/PB) (K815S)	
HRP1001	1-543-835-11	HEAD, MAGNETIC (REC/PB) (K717ES)	

6-6. MECHANISM DECK SECTION 4
(TCM-200V19 : TC-K717ES)
(TCM-200V20 : TC-K815S)

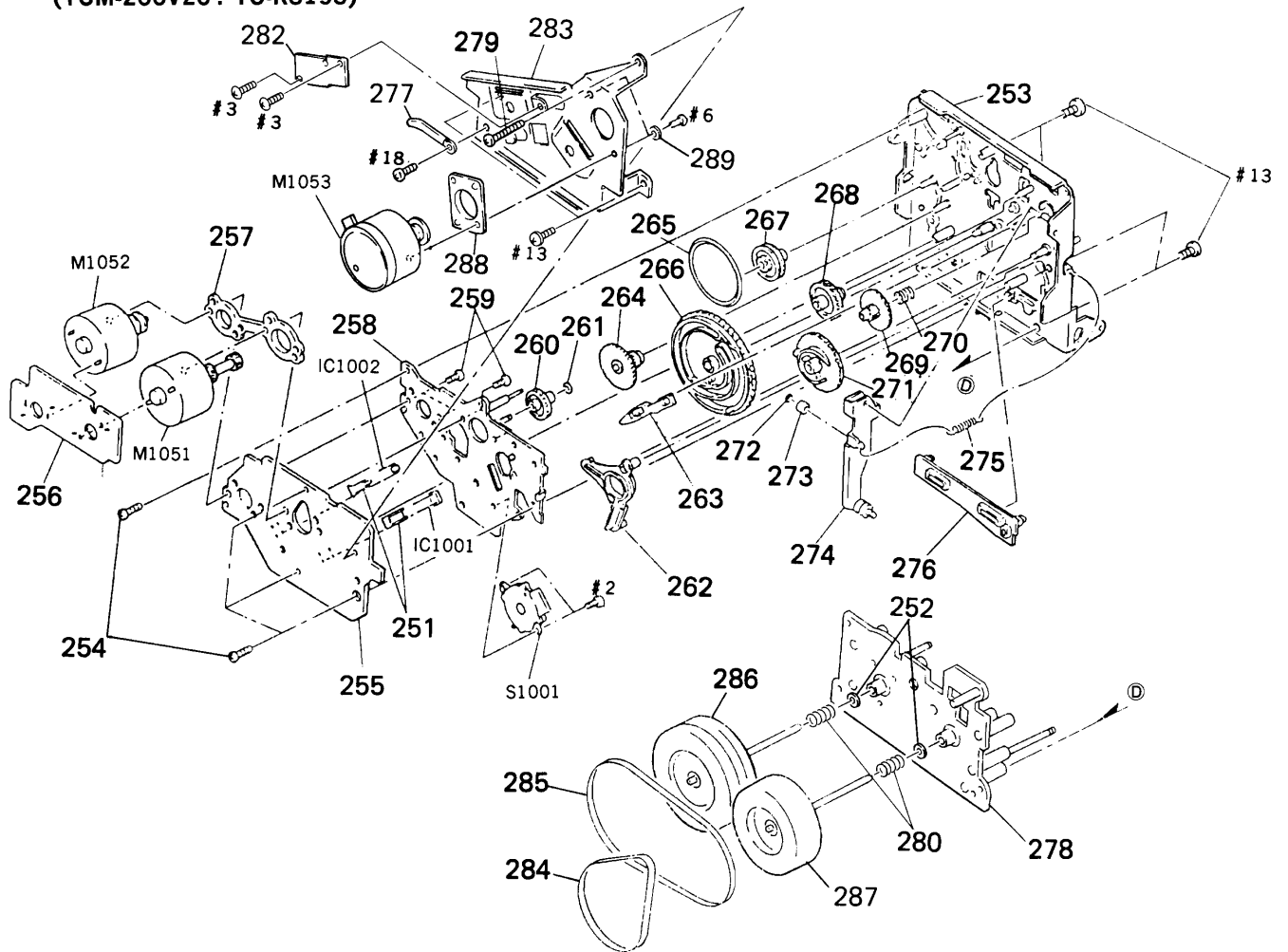

Ref. No.	Part No.	Description	Remark	Ref. No.	Part No.	Description	Remark
251	3-356-631-01	HOLDER (SENSOR)		273	3-356-630-01	ROLLER (LOADING)	
252	3-911-245-01	WASHER (CAPSTAN)		* 274	X-3356-606-1	LEVER (LOADING) ASSY	
* 253	X-3362-862-1	CHASSIS (V4) ASSY, MECHANICAL		275	3-356-624-01	SPRING, TENSION	
254	3-355-801-01	SCREW (BTP 2X18)		276	3-356-653-01	SLIDER (PAUSE)	
* 255	1-632-740-11	MD BOARD		277	3-703-150-11	STOPPER, WIRING	
* 256	1-632-741-11	REEL MOTOR BOARD		* 278	X-3362-865-4	BRACKET (CAPSTAN BASE) ASSY	
* 257	3-356-628-01	SPACER (MOTOR)		279	3-356-707-01	SCREW (+PTPW 2X25)	
* 258	X-3356-616-1	BRACKET (MOTOR D) ASSY		280	3-911-236-01	SPRING, COMPRESSION	
259	3-363-804-01	SCREW (+P 2.6X6.5)		* 282	1-651-596-11	SENSOR BOARD	
260	3-356-702-01	GEAR (COMMUNICATION B)		283	X-3368-006-1	BRACKET ASSY	
261	3-669-465-00	WASHER (1.5), STOPPER		284	3-367-774-01	BELT (CAPSTAN V4)	
262	3-356-613-01	LEVER (MODE)		285	3-364-600-01	BELT (CAPSTAN)	
263	3-356-617-01	LEVER (SELECTION)		286	X-3368-009-1	FLYWHEEL (C-T) ASSY	
264	3-356-606-01	GEAR (MODE)		287	X-3368-010-1	FLYWHEEL (C-S) ASSY	
265	3-356-603-01	BELT (MODE)		288	3-911-241-01	SPACER (A)	
266	3-356-747-01	GEAR (MODE CAM C)		289	3-911-242-01	SPACER (B)	
267	3-356-607-01	PULLEY (MODE)		IC1001	8-749-920-97	PHOTO SENSOR GP2S22B	
268	3-356-703-01	GEAR (COMMUNICATION C)		IC1002	8-749-920-97	PHOTO SENSOR GP2S22B	
269	3-356-609-01	GEAR (LOADING)		M1051	X-3356-638-1	MOTOR (REEL R) ASSY	
270	3-356-605-01	SPRING, COMPRESSION		M1052	X-3356-604-1	MOTOR (ASSIST) ASSY	
271	3-356-616-01	GEAR (LOADING CAM)		M1053	X-3368-008-1	MOTOR (CAPSTAN V19) ASSY	
272	3-558-708-11	WASHER, STOPPER		S1001	1-466-238-11	ENCODER, ROTARY	

DOLBY (S)

**SECTION 7
ELECTRICAL PARTS LIST**

NOTE:

- Due to standardization, replacements in the parts list may be different from the parts specified in the diagrams or the components used on the set.
- -XX and -X mean standardized parts, so they may have some difference from the original one.
- RESISTORS
All resistors are in ohms.
METAL: Metal-film resistor.
METAL OXIDE: Metal oxide-film resistor.
F: nonflammable

- Items marked "*" are not stocked since they are seldom required for routine service. Some delay should be anticipated when ordering these items.
- SEMICONDUCTORS
In each case, u: μ , for example:
uA ..: μ A. uPA..: μ PA..
uPB..: μ PB. uPC..: μ PC. uPD..: μ PD..
- CAPACITORS
uF: μ F
- COILS
uH: μ H

When indicating parts by reference number, please include the board.

The components identified by mark Δ or dotted line with mark Δ are critical for safety. Replace only with part number specified.

Les composants identifiés par une marque Δ sont critiques pour la sécurité. Ne les remplacer que par une pièce portant le numéro spécifié.

• Abbreviations

- AUS : Australian model
- G : German model

Ref. No.	Part No.	Description	Remark
*	A-2007-173-A	DOLBY (S) BOARD, COMPLETE ***** < CAPACITOR >	
C1	1-164-222-11	CERAMIC CHIP 0.22uF	25V
C2	1-135-177-21	TANTALUM CHIP 1uF	20% 20V
C3	1-104-558-11	FILM CHIP 0.039uF	5% 16V
C4	1-163-007-11	CERAMIC CHIP 680PF	10% 50V
C5	1-163-009-11	CERAMIC CHIP 0.001uF	10% 50V
C6	1-164-717-11	CERAMIC CHIP 0.0082uF	5% 50V
C7	1-164-222-11	CERAMIC CHIP 0.22uF	25V
C8	1-104-562-11	FILM CHIP 0.082uF	5% 16V
C9	1-104-553-11	FILM CHIP 0.015uF	5% 16V
C10	1-165-319-11	CERAMIC CHIP 0.1uF	50V
C11	1-135-145-11	TANTALUM CHIP 0.47uF	10% 35V
C12	1-164-222-11	CERAMIC CHIP 0.22uF	25V
C13	1-165-319-11	CERAMIC CHIP 0.1uF	50V
C14	1-162-568-11	CERAMIC CHIP 0.33uF	10% 16V
C15	1-104-562-11	FILM CHIP 0.082uF	5% 16V
C16	1-135-145-11	TANTALUM CHIP 0.47uF	10% 35V
C17	1-165-319-11	CERAMIC CHIP 0.1uF	50V
C18	1-164-222-11	CERAMIC CHIP 0.22uF	25V
C19	1-163-035-00	CERAMIC CHIP 0.047uF	50V
C20	1-104-553-11	FILM CHIP 0.015uF	5% 16V
C21	1-164-717-11	CERAMIC CHIP 0.0082uF	5% 50V
C22	1-163-009-11	CERAMIC CHIP 0.001uF	10% 50V
C23	1-164-161-11	CERAMIC CHIP 0.0022uF	10% 100V
C24	1-163-005-11	CERAMIC CHIP 470PF	10% 50V
C25	1-163-012-00	CERAMIC CHIP 0.0018uF	10% 50V
C26	1-104-558-11	FILM CHIP 0.039uF	5% 16V
C27	1-163-012-00	CERAMIC CHIP 0.0018uF	10% 50V
C28	1-163-012-00	CERAMIC CHIP 0.0018uF	10% 50V
C29	1-104-563-11	FILM CHIP 0.1uF	5% 16V
C30	1-135-145-11	TANTALUM CHIP 0.47uF	10% 35V
C31	1-104-555-11	FILM CHIP 0.022uF	5% 16V
C32	1-104-563-11	FILM CHIP 0.1uF	5% 16V
C33	1-163-024-00	CERAMIC CHIP 0.018uF	10% 50V
C34	1-104-563-11	FILM CHIP 0.1uF	5% 16V
C35	1-163-012-00	CERAMIC CHIP 0.0018uF	10% 50V

Ref. No.	Part No.	Description	Remark
C36	1-165-319-11	CERAMIC CHIP 0.1uF	50V
C37	1-164-222-11	CERAMIC CHIP 0.22uF	25V
C38	1-163-024-00	CERAMIC CHIP 0.018uF	10% 50V
C39	1-104-555-11	FILM CHIP 0.022uF	5% 16V
C40	1-104-563-11	FILM CHIP 0.1uF	5% 16V
		< CONNECTOR >	
CN1	1-695-092-11	SOCKET, CONNECTOR 7P	
		< IC >	
IC1	8-752-056-51	IC CXA1417Q	
		< RESISTOR >	
R1	1-208-353-41	METAL GLAZE 33 2%	1/10W
R2	1-216-675-11	METAL CHIP 10K 0.5%	1/10W
R3	1-208-812-11	METAL GLAZE 18K 2%	1/10W
R4	1-208-556-41	METAL GLAZE 820K 2%	1/10W
R5	1-216-668-11	METAL CHIP 5.1K 0.5%	1/10W
R6	1-208-442-41	METAL GLAZE 1.6K 2%	1/10W
R7	1-216-657-11	METAL CHIP 1.8K 0.5%	1/10W
R8	1-216-667-11	METAL CHIP 4.7K 0.5%	1/10W
R9	1-208-446-41	METAL GLAZE 2.4K 2%	1/10W
R10	1-208-440-41	METAL GLAZE 1.3K 2%	1/10W
R11	1-208-353-41	METAL GLAZE 33 2%	1/10W
R12	1-208-357-41	METAL GLAZE 47 2%	1/10W
R13	1-216-653-11	METAL CHIP 1.2K 0.5%	1/10W
R14	1-216-667-11	METAL CHIP 4.7K 0.5%	1/10W
R15	1-208-446-41	METAL GLAZE 2.4K 2%	1/10W
R16	1-208-353-41	METAL GLAZE 33 2%	1/10W
R17	1-208-357-41	METAL GLAZE 47 2%	1/10W
R18	1-216-657-11	METAL CHIP 1.8K 0.5%	1/10W
R19	1-208-442-41	METAL GLAZE 1.6K 2%	1/10W
R20	1-216-668-11	METAL CHIP 5.1K 0.5%	1/10W
R21	1-208-556-41	METAL GLAZE 820K 2%	1/10W
R22	1-216-655-11	METAL CHIP 1.5K 0.5%	1/10W
R23	1-216-678-11	METAL CHIP 13K 0.5%	1/10W
R24	1-216-673-11	METAL CHIP 8.2K 0.5%	1/10W
R25	1-216-675-11	METAL CHIP 10K 0.5%	1/10W
R26	1-216-676-11	METAL CHIP 11K 0.5%	1/10W

Ref. No.	Part No.	Description	Remark		
R27	1-216-668-11	METAL CHIP	5.1K	0.5%	1/10W
R28	1-216-695-11	METAL CHIP	68K	0.5%	1/10W
R29	1-216-668-11	METAL CHIP	5.1K	0.5%	1/10W
R30	1-208-446-41	METAL GLAZE	2.4K	2%	1/10W
R31	1-216-680-11	METAL CHIP	16K	0.5%	1/10W
R32	1-216-685-11	METAL CHIP	27K	0.5%	1/10W
R33	1-208-469-41	METAL GLAZE	20K	2%	1/10W
R34	1-216-684-11	METAL CHIP	24K	0.5%	1/10W
R35	1-208-521-41	METAL GLAZE	30K	2%	1/10W
R36	1-208-521-41	METAL GLAZE	30K	2%	1/10W
R37	1-216-676-11	METAL CHIP	11K	0.5%	1/10W
R38	1-208-523-41	METAL GLAZE	36K	2%	1/10W
R39	1-216-668-11	METAL CHIP	5.1K	0.5%	1/10W
R40	1-208-521-41	METAL GLAZE	30K	2%	1/10W
R41	1-216-680-11	METAL CHIP	16K	0.5%	1/10W
R42	1-216-673-11	METAL CHIP	8.2K	0.5%	1/10W
R43	1-216-676-11	METAL CHIP	11K	0.5%	1/10W
R44	1-216-689-11	METAL CHIP	39K	0.5%	1/10W
R45	1-216-689-11	METAL CHIP	39K	0.5%	1/10W

*	A-2007-151-A	MAIN BOARD, COMPLETE	(US, Canadian)		
*	A-2007-152-A	MAIN BOARD, COMPLETE	(E)		
*	A-2007-153-A	MAIN BOARD, COMPLETE	(K717ES; AUS)		
*	A-2007-154-A	MAIN BOARD, COMPLETE	(K815S)		
*	A-2007-156-A	MAIN BOARD, COMPLETE	(K715S; AEP, G)		
*	A-2007-157-A	MAIN BOARD, COMPLETE	(K715S; UK, AUS)		

*	3-356-925-01	HEAT SINK			
	7-682-547-09	SCREW +BVTT 3X6 (S)			
< CAPACITOR >					
C101	1-126-059-11	ELECT	10uF	20%	50V
C102	1-162-286-31	CERAMIC	220PF	10%	50V
C103	1-162-211-31	CERAMIC	33PF	5%	50V
C105	1-136-165-00	FILM	0.1uF	5%	50V
C106	1-136-163-00	FILM	0.068uF	5%	50V
C107	1-126-059-11	ELECT	10uF	20%	50V
C108	1-126-045-11	ELECT	2.2uF	20%	50V
C109	1-161-375-00	CERAMIC	0.0022uF	20%	50V
C110	1-126-059-11	ELECT	10uF	20%	50V
C112	1-124-916-11	ELECT	22uF	20%	63V
C113	1-124-907-11	ELECT	10uF	20%	50V
C121	1-110-335-11	MYLAR	100PF	5%	50V
(K717ES)					
C121	1-110-340-11	MYLAR	270PF	5%	50V
(K715S/K815S)					
C122	1-162-282-31	CERAMIC	100PF	10%	50V
C123	1-130-487-00	MYLAR	0.022uF	5%	50V

Ref. No.	Part No.	Description	Remark		
C124	1-124-657-00	ELECT	10uF	20%	50V
C125	1-130-488-00	MYLAR	0.027uF	5%	50V
C126	1-130-474-00	MYLAR	0.0018uF	5%	50V
C127	1-102-966-00	CERAMIC	43PF	5%	50V
C128	1-130-474-00	MYLAR	0.0018uF	5%	50V
C133	1-136-165-00	FILM	0.1uF	5%	50V
C134	1-136-163-00	FILM	0.068uF	5%	50V
C135	1-126-045-11	ELECT	2.2uF	20%	50V
C141	1-136-175-00	FILM	0.68uF	5%	50V
C142	1-126-059-11	ELECT	10uF	20%	50V
C143	1-126-059-11	ELECT	10uF	20%	50V
C144	1-110-338-51	MYLAR	180PF	5%	50V
C145	1-107-210-00	MICA	22PF	5%	500V
C146	1-130-475-00	MYLAR	0.0022uF	5%	50V
C161	1-124-925-11	ELECT	2.2uF	20%	100V
C163	1-124-916-11	ELECT	22uF	20%	63V
C164	1-124-907-11	ELECT	10uF	20%	50V
C181	1-136-153-00	FILM	0.01uF	5%	50V
C182	1-136-157-00	FILM	0.022uF	5%	50V
C183	1-136-161-00	FILM	0.047uF	5%	50V
C184	1-136-803-11	FILM	560PF	5%	630V
C185	1-107-169-00	MICA	100PF	5%	500V
C186	1-130-468-00	MYLAR	560PF	5%	50V
C201	1-126-059-11	ELECT	10uF	20%	50V
C202	1-162-286-31	CERAMIC	220PF	10%	50V
C203	1-162-211-31	CERAMIC	33PF	5%	50V
C205	1-136-165-00	FILM	0.1uF	5%	50V
C206	1-136-163-00	FILM	0.068uF	5%	50V
C207	1-126-059-11	ELECT	10uF	20%	50V
C208	1-126-045-11	ELECT	2.2uF	20%	50V
C209	1-161-375-00	CERAMIC	0.0022uF	20%	50V
C210	1-126-059-11	ELECT	10uF	20%	50V
C212	1-124-916-11	ELECT	22uF	20%	63V
C213	1-124-907-11	ELECT	10uF	20%	50V
C221	1-110-335-11	MYLAR	100PF	5%	50V
(K717ES)					
C221	1-110-340-11	MYLAR	270PF	5%	50V
(K715S/K815S)					
C222	1-162-282-31	CERAMIC	100PF	10%	50V
C223	1-130-487-00	MYLAR	0.022uF	5%	50V
C224	1-124-657-00	ELECT	10uF	20%	50V
C225	1-130-488-00	MYLAR	0.027uF	5%	50V
C226	1-130-474-00	MYLAR	0.0018uF	5%	50V
C227	1-102-966-00	CERAMIC	43PF	5%	50V
C228	1-130-474-00	MYLAR	0.0018uF	5%	50V
C233	1-136-165-00	FILM	0.1uF	5%	50V
C234	1-136-163-00	FILM	0.068uF	5%	50V
C235	1-126-045-11	ELECT	2.2uF	20%	50V
C241	1-136-175-00	FILM	0.68uF	5%	50V

Ref. No.	Part No.	Description	Remark
* CN701	1-580-230-31	PIN, CONNECTOR (PC BOARD) 2P (EXCEPT K717ES:E, AUS)	
* CN801	1-568-845-11	SOCKET, CONNECTOR 31P	
* CN802	1-568-830-11	SOCKET, CONNECTOR 11P	
* CND512	1-564-339-00	PIN, CONNECTOR 5P	
* CND518	1-564-337-00	PIN, CONNECTOR 3P	
* CND801	1-564-338-00	PIN, CONNECTOR 4P	
* CND802	1-564-337-61	PIN, CONNECTOR 3P	
* CNE501	1-564-521-11	PLUG, CONNECTOR 6P	
* CNE522	1-564-505-11	PLUG, CONNECTOR 2P (K717ES/K815S)	
* CNE701	1-564-507-11	PLUG, CONNECTOR 4P	
* CNE702	1-564-505-11	PLUG, CONNECTOR 2P	
* CNE801	1-564-513-11	PLUG, CONNECTOR 10P	
* CNN515	1-560-062-00	PIN, CONNECTOR 4P	
* CNN516	1-560-062-00	PIN, CONNECTOR 4P	
* CNN517	1-560-060-00	PIN, CONNECTOR 2P (K715S)	
* CNN517	1-560-061-00	PIN, CONNECTOR 3P (K717ES/K815S)	
* CNP513	1-564-707-11	PIN, CONNECTOR (SMALL TYPE) 5P	
* CNP514	1-564-707-11	PIN, CONNECTOR (SMALL TYPE) 5P	
< DIODE >			
D101	8-719-987-63	DIODE 1N4148M	
D102	8-719-987-63	DIODE 1N4148M	
D201	8-719-987-63	DIODE 1N4148M	
D202	8-719-987-63	DIODE 1N4148M	
D502	8-719-987-63	DIODE 1N4148M	
D503	8-719-987-63	DIODE 1N4148M	
D504	8-719-987-63	DIODE 1N4148M	
D505	8-719-987-63	DIODE 1N4148M	
D507	8-719-987-63	DIODE 1N4148M	
D508	8-719-987-63	DIODE 1N4148M	
D509	8-719-987-63	DIODE 1N4148M	
D510	8-719-987-63	DIODE 1N4148M	
D511	8-719-987-63	DIODE 1N4148M	
D512	8-719-987-63	DIODE 1N4148M	
D513	8-719-987-63	DIODE 1N4148M	
D514	8-719-987-63	DIODE 1N4148M	
D515	8-719-987-63	DIODE 1N4148M	
D516	8-719-987-63	DIODE 1N4148M	
D517	8-719-987-63	DIODE 1N4148M	
D518	8-719-107-94	DIODE 1SS202-1	
D519	8-719-107-94	DIODE 1SS202-1	
D520	8-719-107-94	DIODE 1SS202-1	
D521	8-719-107-94	DIODE 1SS202-1	
D531	8-719-987-63	DIODE 1N4148M	
D703	8-719-987-63	DIODE 1N4148M	
D704	8-719-987-63	DIODE 1N4148M	
D705	8-719-987-63	DIODE 1N4148M	
D707	8-719-987-63	DIODE 1N4148M	

Ref. No.	Part No.	Description	Remark
D708	8-719-933-33	DIODE HZS6A1L	
D709	8-719-933-33	DIODE HZS6A1L	
D801	8-719-200-77	DIODE 10E2N	
D802	8-719-200-77	DIODE 10E2N	
D803	8-719-200-77	DIODE 10E2N	
D804	8-719-200-77	DIODE 10E2N	
D805	8-719-933-33	DIODE HZS6A1L	
D806	8-719-933-33	DIODE HZS6A1L	
D807	8-719-987-63	DIODE 1N4148M	
D812	8-719-987-63	DIODE 1N4148M	
D813	8-719-200-31	DIODE 21DQ05	
D814	8-719-000-78	DIODE UZL-7L2	
D815	8-719-987-63	DIODE 1N4148M	
D816	8-719-987-63	DIODE 1N4148M	
D817	8-719-001-70	DIODE UZL-12M1	
D818	8-719-200-77	DIODE 10E2N	
D819	8-719-200-77	DIODE 10E2N	
D820	8-719-000-93	DIODE UZL-7H1	
D822	8-719-987-63	DIODE 1N4148M	
D823	8-719-312-09	DIODE RBA-402	
D824	8-719-987-63	DIODE 1N4148M	
< IC >			
IC501	8-752-066-35	IC CXA1563S	
IC502	8-759-000-49	IC MC14066BCP	
IC503	8-752-060-64	IC CXA1198AP	
IC504	8-759-106-56	IC uPC1297CA	
IC505	8-759-111-44	IC uPC4570C-1	
IC506	8-752-066-35	IC CXA1563S	
IC507	8-759-634-51	IC M5218AP	
IC508	8-759-145-58	IC uPC4558C	
IC509	8-759-145-58	IC uPC4558C	
IC510	8-759-634-51	IC M5218AP	
IC511	8-759-634-51	IC M5218AP	
IC701	8-759-254-84	IC uPD78042GF-071-3B9	
IC702	8-759-165-85	IC PST600H-T	
IC703	8-759-973-95	IC BA6219B	
IC704	8-759-822-09	IC LB1641	
IC801	8-759-145-58	IC uPC4558C	
< JACK >			
J501	1-565-258-11	JACK, PIN 4P (LINE IN/OUT) (K715S/K815S)	
J501	1-573-070-11	JACK, PIN 4P (LINE IN/OUT) (K717ES)	
J502	1-750-735-11	JACK (LARGE TYPE) (HEADPHONES)	
< COIL >			
L121	1-410-778-11	INDUCTOR 18mH	
L141	1-410-780-11	INDUCTOR 27mH	

MAIN

Ref. No.	Part No.	Description	Remark	Ref. No.	Part No.	Description	Remark
L221	1-410-778-11	INDUCTOR	18mH	Q716	8-729-900-89	TRANSISTOR	DTC144ES
L241	1-410-780-11	INDUCTOR	27mH	Q717	8-729-900-61	TRANSISTOR	DTA114ES
		< FILTER >		Q718	8-729-900-61	TRANSISTOR	DTA114ES
LPF101	1-236-147-11	FILTER, LOW PASS		Q720	8-729-900-89	TRANSISTOR	DTC144ES
LPF201	1-236-147-11	FILTER, LOW PASS		Q801	8-729-900-61	TRANSISTOR	DTA114ES
		< TRANSISTOR >		Q802	8-729-900-80	TRANSISTOR	DTC114ES
Q101	8-729-922-37	TRANSISTOR	2SD2144S-UVW	Q803	8-729-141-83	TRANSISTOR	2SB1094-LK
Q102	8-729-922-37	TRANSISTOR	2SD2144S-UVW	Q804	8-729-209-15	TRANSISTOR	2SD2012
Q103	8-729-900-74	TRANSISTOR	DTC143TS	Q805	8-729-209-15	TRANSISTOR	2SD2012
Q104	8-729-900-80	TRANSISTOR	DTC114ES	Q806	8-729-620-05	TRANSISTOR	2SC2603-EF
Q105	8-729-900-80	TRANSISTOR	DTC114ES	Q807	8-729-900-80	TRANSISTOR	DTC114ES
Q201	8-729-922-37	TRANSISTOR	2SD2144S-UVW	Q808	8-729-141-83	TRANSISTOR	2SB1094-LK
Q202	8-729-922-37	TRANSISTOR	2SD2144S-UVW	Q809	8-729-620-05	TRANSISTOR	2SC2603-EF
Q203	8-729-900-74	TRANSISTOR	DTC143TS	Q810	8-729-119-76	TRANSISTOR	2SA1175-HFE
Q204	8-729-900-80	TRANSISTOR	DTC114ES	Q811	8-729-140-04	TRANSISTOR	2SB1116A-L
Q205	8-729-900-80	TRANSISTOR	DTC114ES			< RESISTOR >	
Q501	8-729-620-05	TRANSISTOR	2SC2603-EF	R101	1-259-460-11	CARBON	22K 5% 1/6W
Q502	8-729-620-05	TRANSISTOR	2SC2603-EF	R104	1-259-440-11	CARBON	3.3K 5% 1/6W
Q503	8-729-922-37	TRANSISTOR	2SD2144S-UVW	R105	1-259-450-11	CARBON	8.2K 5% 1/6W
Q504	8-729-900-80	TRANSISTOR	DTC114ES	R109	1-259-436-11	CARBON	2.2K 5% 1/6W
Q505	8-729-119-76	TRANSISTOR	2SA1175-HFE	R110	1-259-436-11	CARBON	2.2K 5% 1/6W
Q506	8-729-142-25	TRANSISTOR	2SD1020-HFE	R111	1-259-467-11	CARBON	43K 5% 1/6W
Q507	8-729-900-80	TRANSISTOR	DTC114ES	R112	1-259-428-11	CARBON	1K 5% 1/6W
Q508	8-729-119-76	TRANSISTOR	2SA1175-HFE	R113	1-259-476-11	CARBON	100K 5% 1/6W
Q509	8-729-900-80	TRANSISTOR	DTC114ES	R114	1-259-484-11	CARBON	220K 5% 1/6W
Q510	8-729-900-80	TRANSISTOR	DTC114ES	R115	1-259-436-11	CARBON	2.2K 5% 1/6W
Q511	8-729-194-57	TRANSISTOR	2SC945-P	R116	1-259-476-11	CARBON	100K 5% 1/6W
Q512	8-729-194-57	TRANSISTOR	2SC945-P	R121	1-259-466-11	CARBON	39K 5% 1/6W
Q513	8-729-900-80	TRANSISTOR	DTC114ES			(K717ES)	
Q514	8-729-900-80	TRANSISTOR	DTC114ES	R121	1-259-476-11	CARBON	100K 5% 1/6W
Q515	8-729-900-80	TRANSISTOR	DTC114ES			(K715S/K815S)	
Q516	8-729-900-89	TRANSISTOR	DTC144ES	R122	1-259-402-11	CARBON	82 5% 1/6W
Q517	8-729-900-80	TRANSISTOR	DTC114ES	R123	1-259-479-11	CARBON	130K 5% 1/6W
Q520	8-729-900-74	TRANSISTOR	DTC143TS	R124	1-259-446-11	CARBON	5.6K 5% 1/6W
Q701	8-729-900-80	TRANSISTOR	DTC114ES	R125	1-259-434-11	CARBON	1.8K 5% 1/6W
Q702	8-729-900-80	TRANSISTOR	DTC114ES	R126	1-259-435-11	CARBON	2K 5% 1/6W
Q703	8-729-620-05	TRANSISTOR	2SC2603-EF	R142	1-259-442-11	CARBON	3.9K 5% 1/6W
Q705	8-729-119-76	TRANSISTOR	2SA1175-HFE	R143	1-259-440-11	CARBON	3.3K 5% 1/6W
Q706	8-729-119-76	TRANSISTOR	2SA1175-HFE	R144	1-259-452-11	CARBON	10K 5% 1/6W
Q707	8-729-900-61	TRANSISTOR	DTA114ES	R145	1-259-436-11	CARBON	2.2K 5% 1/6W
Q708	8-729-900-61	TRANSISTOR	DTA114ES	R146	1-259-444-11	CARBON	4.7K 5% 1/6W
Q710	8-729-900-80	TRANSISTOR	DTC114ES	R147	1-259-444-11	CARBON	4.7K 5% 1/6W
Q712	8-729-900-80	TRANSISTOR	DTC114ES	R151	1-259-460-11	CARBON	22K 5% 1/6W
Q713	8-729-900-89	TRANSISTOR	DTC144ES	R152	1-259-436-11	CARBON	2.2K 5% 1/6W
Q714	8-729-900-61	TRANSISTOR	DTA114ES	R153	1-259-459-11	CARBON	20K 5% 1/6W
Q715	8-729-900-89	TRANSISTOR	DTC144ES	R154	1-259-412-11	CARBON	220 5% 1/6W
				R161	1-259-462-11	CARBON	27K 5% 1/6W
				R162	1-259-471-11	CARBON	62K 5% 1/6W

Ref. No.	Part No.	Description	Remark		
R163	1-259-414-11	CARBON	270	5%	1/6W
R164	1-259-476-11	CARBON	100K	5%	1/6W
R181	1-259-446-11	CARBON	5.6K	5%	1/6W
		(K715S/K815S)			
R181	1-259-450-11	CARBON	8.2K	5%	1/6W
		(K717ES)			
R182	1-259-464-11	CARBON	33K	5%	1/6W
△R183	1-219-153-11	FUSIBLE	10	5%	1/4W F
R184	1-259-480-11	CARBON	150K	5%	1/6W
R191	1-259-461-11	CARBON	24K	5%	1/6W
R192	1-259-452-11	CARBON	10K	5%	1/6W
R193	1-259-476-11	CARBON	100K	5%	1/6W
R201	1-259-460-11	CARBON	22K	5%	1/6W
R204	1-259-440-11	CARBON	3.3K	5%	1/6W
R205	1-259-450-11	CARBON	8.2K	5%	1/6W
R209	1-259-436-11	CARBON	2.2K	5%	1/6W
R210	1-259-436-11	CARBON	2.2K	5%	1/6W
R211	1-259-467-11	CARBON	43K	5%	1/6W
R212	1-259-428-11	CARBON	1K	5%	1/6W
R213	1-259-476-11	CARBON	100K	5%	1/6W
R214	1-259-484-11	CARBON	220K	5%	1/6W
R215	1-259-436-11	CARBON	2.2K	5%	1/6W
R216	1-259-476-11	CARBON	100K	5%	1/6W
R221	1-259-466-11	CARBON	39K	5%	1/6W
		(K717ES)			
R221	1-259-476-11	CARBON	100K	5%	1/6W
		(K715S/K815S)			
R222	1-259-402-11	CARBON	82	5%	1/6W
R223	1-259-479-11	CARBON	130K	5%	1/6W
R224	1-259-446-11	CARBON	5.6K	5%	1/6W
R225	1-259-434-11	CARBON	1.8K	5%	1/6W
R226	1-259-435-11	CARBON	2K	5%	1/6W
R242	1-259-442-11	CARBON	3.9K	5%	1/6W
R243	1-259-440-11	CARBON	3.3K	5%	1/6W
R244	1-259-452-11	CARBON	10K	5%	1/6W
R245	1-259-436-11	CARBON	2.2K	5%	1/6W
R246	1-259-444-11	CARBON	4.7K	5%	1/6W
R247	1-259-444-11	CARBON	4.7K	5%	1/6W
R251	1-259-460-11	CARBON	22K	5%	1/6W
R252	1-259-436-11	CARBON	2.2K	5%	1/6W
R253	1-259-459-11	CARBON	20K	5%	1/6W
R254	1-259-412-11	CARBON	220	5%	1/6W
R261	1-259-462-11	CARBON	27K	5%	1/6W
R262	1-259-471-11	CARBON	62K	5%	1/6W
R263	1-259-414-11	CARBON	270	5%	1/6W
R264	1-259-476-11	CARBON	100K	5%	1/6W
R281	1-259-446-11	CARBON	5.6K	5%	1/6W
		(K715S/K815S)			
R281	1-259-450-11	CARBON	8.2K	5%	1/6W
		(K717ES)			

Ref. No.	Part No.	Description	Remark		
R282	1-259-464-11	CARBON	33K	5%	1/6W
△R283	1-219-153-11	FUSIBLE	10	5%	1/4W F
R284	1-259-480-11	CARBON	150K	5%	1/6W
R291	1-259-461-11	CARBON	24K	5%	1/6W
R292	1-259-452-11	CARBON	10K	5%	1/6W
R293	1-259-476-11	CARBON	100K	5%	1/6W
R502	1-215-452-00	METAL	20K	1%	1/6W
R504	1-249-413-11	CARBON	470	5%	1/4W (K715S)
R505	1-249-427-11	CARBON	6.8K	5%	1/4W
R506	1-249-381-11	CARBON	1	5%	1/4W
		(K717ES/K815S)			
R507	1-249-425-11	CARBON	4.7K	5%	1/4W
R508	1-249-433-11	CARBON	22K	5%	1/4W
R509	1-249-436-11	CARBON	39K	5%	1/4W
R510	1-249-421-11	CARBON	2.2K	5%	1/4W
R511	1-249-421-11	CARBON	2.2K	5%	1/4W
R512	1-249-441-11	CARBON	100K	5%	1/4W
R513	1-249-441-11	CARBON	100K	5%	1/4W
R514	1-247-836-11	CARBON	1.6K	5%	1/4W
R516	1-249-437-11	CARBON	47K	5%	1/4W
R517	1-249-421-11	CARBON	2.2K	5%	1/4W
R518	1-249-427-11	CARBON	6.8K	5%	1/4W
R519	1-249-437-11	CARBON	47K	5%	1/4W
R520	1-249-434-11	CARBON	27K	5%	1/4W
R521	1-247-704-11	CARBON	220	5%	1/4W
R522	1-247-704-11	CARBON	220	5%	1/4W
R524	1-249-429-11	CARBON	10K	5%	1/4W
R531	1-249-441-11	CARBON	100K	5%	1/4W
R532	1-215-452-00	METAL	20K	1%	1/6W
R533	1-249-437-11	CARBON	47K	5%	1/4W
R534	1-249-441-11	CARBON	100K	5%	1/4W
R535	1-215-454-00	METAL	24K	1%	1/6W
R540	1-249-429-11	CARBON	10K	5%	1/4W
R541	1-215-445-00	METAL	10K	1%	1/6W
R542	1-215-453-00	METAL	22K	1%	1/6W
R563	1-249-441-11	CARBON	100K	5%	1/4W
R564	1-249-429-11	CARBON	10K	5%	1/4W
R565	1-249-441-11	CARBON	100K	5%	1/4W
R566	1-249-428-11	CARBON	8.2K	5%	1/4W
R567	1-249-441-11	CARBON	100K	5%	1/4W
R568	1-249-423-11	CARBON	3.3K	5%	1/4W
R569	1-249-441-11	CARBON	100K	5%	1/4W
R570	1-249-429-11	CARBON	10K	5%	1/4W
R571	1-249-429-11	CARBON	10K	5%	1/4W
R572	1-249-417-11	CARBON	1K	5%	1/4W
R581	1-249-429-11	CARBON	10K	5%	1/4W
R582	1-249-429-11	CARBON	10K	5%	1/4W
R583	1-247-822-11	CARBON	430	5%	1/4W
		(K715S/K815S)			

The components identified by mark △ or dotted line with mark △ are critical for safety. Replace only with part number specified.

Les composants identifiés par une marque △ sont critiques pour la sécurité. Ne les remplacer que par une pièce portant le numéro spécifié.

MAIN

Ref. No.	Part No.	Description	Remark
R583	1-249-414-11	CARBON (K717ES)	560 5% 1/4W
R584	1-249-417-11	CARBON	1K 5% 1/4W
R585	1-247-862-11	CARBON (K715S/K815S)	20K 5% 1/4W
R585	1-249-433-11	CARBON (K717ES)	22K 5% 1/4W
R586	1-249-417-11	CARBON	1K 5% 1/4W
R587	1-249-436-11	CARBON (K717ES/K815S)	39K 5% 1/4W
R587	1-249-440-11	CARBON	82K 5% 1/4W (K715S)
R588	1-249-436-11	CARBON (K717ES/K815S)	39K 5% 1/4W
R588	1-249-440-11	CARBON	82K 5% 1/4W (K715S)
R589	1-249-390-11	CARBON	5.6 5% 1/6W (K715S)
R589	1-249-391-11	CARBON (K717ES/K815S)	6.8 5% 1/4W
R590	1-249-390-11	CARBON	5.6 5% 1/6W (K715S)
R590	1-249-391-11	CARBON (K717ES/K815S)	6.8 5% 1/4W
R591	1-249-421-11	CARBON	2.2K 5% 1/4W
R593	1-249-429-11	CARBON	10K 5% 1/4W
R594	1-249-429-11	CARBON	10K 5% 1/4W
R601	1-247-878-00	CARBON (K717ES)	91K 5% 1/4W
R601	1-249-439-11	CARBON (K715S/K815S)	68K 5% 1/4W
R602	1-249-435-11	CARBON	33K 5% 1/4W
R603	1-247-878-00	CARBON (K717ES)	91K 5% 1/4W
R603	1-249-437-11	CARBON (K715S/K815S)	47K 5% 1/4W
R604	1-247-874-11	CARBON (K715S/K815S)	62K 5% 1/4W
R604	1-247-876-11	CARBON (K717ES)	75K 5% 1/4W
R605	1-249-439-11	CARBON (K717ES)	68K 5% 1/4W
R605	1-249-441-11	CARBON (K715S/K815S)	100K 5% 1/4W
R606	1-249-433-11	CARBON	22K 5% 1/4W
R607	1-247-874-11	CARBON	62K 5% 1/4W
R608	1-247-872-11	CARBON (K717ES)	51K 5% 1/4W
R608	1-249-437-11	CARBON (K715S/K815S)	47K 5% 1/4W
R609	1-247-880-11	CARBON (K715S/K815S)	110K 5% 1/4W
R609	1-247-882-11	CARBON (K717ES)	130K 5% 1/4W
R610	1-247-876-11	CARBON (K717ES)	75K 5% 1/4W

Ref. No.	Part No.	Description	Remark
R610	1-247-878-00	CARBON (K715S/K815S)	91K 5% 1/4W
R611	1-249-438-11	CARBON (K717ES)	56K 5% 1/4W
R611	1-249-439-11	CARBON (K715S/K815S)	68K 5% 1/4W
R612	1-247-887-00	CARBON	220K 5% 1/4W
R613	1-249-440-11	CARBON	82K 5% 1/4W
R614	1-249-438-11	CARBON	56K 5% 1/4W
R616	1-247-874-11	CARBON (K715S/K815S)	62K 5% 1/4W
R616	1-249-437-11	CARBON (K717ES)	47K 5% 1/4W
R617	1-247-874-11	CARBON (K715S/K815S)	62K 5% 1/4W
R617	1-249-440-11	CARBON (K717ES)	82K 5% 1/4W
R618	1-247-883-00	CARBON (K717ES)	150K 5% 1/4W
R618	1-247-886-11	CARBON (K715S/K815S)	200K 5% 1/4W
R619	1-249-435-11	CARBON	33K 5% 1/4W
R701	1-249-417-11	CARBON	1K 5% 1/4W
R702	1-249-441-11	CARBON	100K 5% 1/4W
R703	1-249-436-11	CARBON	39K 5% 1/4W
R704	1-249-429-11	CARBON	10K 5% 1/4W
R705	1-249-436-11	CARBON	39K 5% 1/4W
R706	1-249-429-11	CARBON	10K 5% 1/4W
R707	1-249-431-11	CARBON	15K 5% 1/4W
R708	1-247-868-11	CARBON	36K 5% 1/4W
R709	1-249-435-11	CARBON	33K 5% 1/4W
R710	1-249-435-11	CARBON	33K 5% 1/4W
R711	1-247-878-00	CARBON (K717ES/K815S)	91K 5% 1/4W
R711	1-249-429-11	CARBON	10K 5% 1/4W (K715S)
R712-717	1-249-429-11	CARBON	10K 5% 1/4W
R719	1-249-429-11	CARBON	10K 5% 1/4W
△R720	1-212-954-11	FUSIBLE	6.8 5% 1/2W F
R721	1-249-429-11	CARBON	10K 5% 1/4W
R722	1-249-431-11	CARBON	15K 5% 1/4W
R723	1-247-834-11	CARBON	1.3K 5% 1/4W
R724	1-249-424-11	CARBON	3.9K 5% 1/4W
R725	1-247-834-11	CARBON	1.3K 5% 1/4W
R726	1-249-427-11	CARBON	6.8K 5% 1/4W
R727	1-249-430-11	CARBON	12K 5% 1/4W
△R728	1-212-952-00	FUSIBLE	5.6 5% 1/2W F
R729	1-249-409-11	CARBON	220 5% 1/4W
R730	1-249-419-11	CARBON	1.5K 5% 1/4W
R731	1-249-429-11	CARBON	10K 5% 1/4W
R732	1-247-883-00	CARBON	150K 5% 1/4W

The components identified by mark △ or dotted line with mark. △ are critical for safety. Replace only with part number specified.

Les composants identifiés par une marque △ sont critiques pour la sécurité. Ne les remplacer que par une pièce portant le numéro spécifié.

Ref. No.	Part No.	Description			Remark
R733	1-249-437-11	CARBON	47K	5%	1/4W
R734	1-249-437-11	CARBON	47K	5%	1/4W
R735	1-249-421-11	CARBON	2.2K	5%	1/4W
△R736	1-212-942-00	FUSIBLE	2.2	5%	1/2W F
R737-739					
	1-249-429-11	CARBON	10K	5%	1/4W
R740	1-249-436-11	CARBON	39K	5%	1/4W
R741	1-247-860-11	CARBON	16K	5%	1/4W
		(K717ES/K815S)			
R741	1-249-432-11	CARBON	18K	5%	1/4W
		(K715S)			
R742-744					
	1-249-441-11	CARBON	100K	5%	1/4W
R745-747					
	1-249-429-11	CARBON	10K	5%	1/4W
R751	1-249-429-11	CARBON	10K	5%	1/4W
R799	1-247-807-31	CARBON	100	5%	1/4W
R802	1-249-425-11	CARBON	4.7K	5%	1/4W
R803	1-249-420-11	CARBON	1.8K	5%	1/4W
R804	1-249-412-11	CARBON	390	5%	1/4W
R805	1-249-427-11	CARBON	6.8K	5%	1/4W
R806	1-249-419-11	CARBON	1.5K	5%	1/4W
R807	1-249-429-11	CARBON	10K	5%	1/4W
R808	1-249-419-11	CARBON	1.5K	5%	1/4W
R809	1-249-425-11	CARBON	4.7K	5%	1/4W
R810	1-249-409-11	CARBON	220	5%	1/4W
R811	1-249-417-11	CARBON	1K	5%	1/4W
R812	1-249-427-11	CARBON	6.8K	5%	1/4W
R813	1-249-427-11	CARBON	6.8K	5%	1/4W
R814	1-249-417-11	CARBON	1K	5%	1/4W
R815-817					
	1-249-425-11	CARBON	4.7K	5%	1/4W
R818	1-249-433-11	CARBON	22K	5%	1/4W
R819	1-249-436-11	CARBON	39K	5%	1/4W
R820	1-247-854-11	CARBON	9.1K	5%	1/4W
R821	1-249-437-11	CARBON	47K	5%	1/4W
△R825	1-219-135-11	FUSIBLE	0.15	10%	1/4W F
△R826	1-219-137-11	FUSIBLE	0.33	10%	1/4W F
< VARIABLE RESISTOR >					
RV121	1-241-763-11	RES. ADJ. CARBON 4.7K			
RV141	1-241-765-11	RES. ADJ. CARBON 22K			
RV142	1-238-019-11	RES. ADJ. CARBON 47K			
RV181	1-241-765-11	RES. ADJ. CARBON 22K			
RV221	1-241-763-11	RES. ADJ. CARBON 4.7K			
RV241	1-241-765-11	RES. ADJ. CARBON 22K			
RV242	1-238-019-11	RES. ADJ. CARBON 47K			
RV281	1-241-765-11	RES. ADJ. CARBON 22K			
RV501	1-223-328-11	RES. VAR. CARBON 50K/50K (REC LEVEL)			
RV502	1-223-331-11	RES. VAR. CARBON 50K/50K (BALANCE)			

Ref. No.	Part No.	Description			Remark
RV504	1-241-763-11	RES. ADJ. CARBON 4.7K (K717ES/K815S)			
RV505	1-223-330-11	RES. VAR. CARBON 20K/20K (PHONE LEVEL)			
RV508	1-223-387-21	RES. ADJ. CARBON 330K (K715S/K815S)			
RV508	1-241-768-11	RES. ADJ. CARBON 220K (K717ES)			
< TRANSFORMER >					
T181	1-433-344-11	TRANSFORMER, BIAS OSCILLATION			
T281	1-433-344-11	TRANSFORMER, BIAS OSCILLATION			
T501	1-423-621-11	TRANSFORMER, BIAS OSCILLATION (K715S)			
T501	1-433-380-11	TRANSFORMER, BIAS OSCILLATION (K717ES/K815S)			
< TEST PIN >					
* TP581	1-564-506-11	PLUG, CONNECTOR 3P			
< VIBRATOR >					
X701	1-579-066-31	VIBRATOR, CRYSTAL (4.19MHz)			

* 1-632-740-11		MD BOARD			

3-356-631-01		HOLDER (SENSOR)			
< CONNECTOR >					
CN1001	1-506-615-11	PIN, CONNECTOR 9P			
* CN1002	1-564-502-11	PIN, CONNECTOR 10P			
< IC >					
IC1001	8-749-920-97	PHOTO SENSOR	GP2S22B		
IC1002	8-749-920-97	PHOTO SENSOR	GP2S22B		
< RESISTOR >					
R1001	1-249-408-11	CARBON	180	5%	1/4W
R1002	1-249-408-11	CARBON	180	5%	1/4W
< SWITCH >					
S1002	1-570-953-11	SWITCH, PUSH (1 KEY) (DOOR)			
S1003	1-571-958-11	SWITCH, PUSH (1 KEY) (CLOSE)			
S1004	1-572-126-11	SWITCH, PUSH (1 KEY) (OPEN)			
S1005	1-572-125-11	SWITCH, LEAF (FWD)			
S1006	1-572-202-11	SWITCH, LEAF (HALF)			
S1007	1-572-125-11	SWITCH, LEAF (METAL)			
S1008	1-572-125-11	SWITCH, LEAF (70μ)			
< TERMINAL >					
* TB1001	1-694-018-11	TERMINAL (5P)			

<p>The components identified by mark △ or dotted line with mark △ are critical for safety. Replace only with part number specified.</p>	<p>Les composants identifiés par une marque △ sont critiques pour la sécurité. Ne les remplacer que par une pièce portant le numéro spécifié.</p>
---	---

PANEL

REEL MOTOR

Ref. No.	Part No.	Description	Remark
*	A-2007-161-A	PANEL BOARD, COMPLETE (K717ES/K815S)	
*	A-2007-231-A	PANEL BOARD, COMPLETE (K715S)	

*	3-386-245-01	HOLDER (FL)	
< CONNECTOR >			
* CN901	1-568-845-11	SOCKET, CONNECTOR 31P	
* CN902	1-568-830-11	SOCKET, CONNECTOR 11P	
< DIODE >			
D751	8-719-987-63	DIODE 1N4148M	
D752	8-719-987-63	DIODE 1N4148M	
D753	8-719-987-63	DIODE 1N4148M	
< FLUORESCENT INDICATOR >			
FLT751	1-517-163-11	INDICATOR TUBE, FLUORESCENT	
< IC >			
IC751	8-741-100-48	IC SBX1610-59	
< RESISTOR >			
R141	1-259-444-11	CARBON 4.7K 5% 1/6W	
R241	1-259-444-11	CARBON 4.7K 5% 1/6W	
R592	1-249-429-11	CARBON 10K 5% 1/4W	
R749	1-249-422-11	CARBON 2.7K 5% 1/4W	
R750	1-247-836-11	CARBON 1.6K 5% 1/4W (K715S)	
R750	1-249-430-11	CARBON 12K 5% 1/4W (K717ES/K815S)	
R752	1-247-838-00	CARBON 2K 5% 1/4W	
R753	1-249-422-11	CARBON 2.7K 5% 1/4W	
R754	1-249-426-11	CARBON 5.6K 5% 1/4W	
R755	1-247-856-00	CARBON 11K 5% 1/4W	
R756	1-247-866-11	CARBON 30K 5% 1/4W	
R759	1-247-838-00	CARBON 2K 5% 1/4W	
R760	1-249-422-11	CARBON 2.7K 5% 1/4W	
R761	1-249-426-11	CARBON 5.6K 5% 1/4W	
R762	1-247-856-00	CARBON 11K 5% 1/4W	
R763	1-247-838-00	CARBON 2K 5% 1/4W	
R764	1-247-866-11	CARBON 30K 5% 1/4W	
R766	1-249-426-11	CARBON 5.6K 5% 1/4W	
R768	1-247-856-00	CARBON 11K 5% 1/4W	
R769	1-247-866-11	CARBON 30K 5% 1/4W	
R770	1-249-427-11	CARBON 6.8K 5% 1/4W (K715S)	
R771	1-247-807-31	CARBON 100 5% 1/4W (K715S)	
R771	1-249-431-11	CARBON 15K 5% 1/4W (K717ES/K815S)	
R955	1-249-441-11	CARBON 100K 5% 1/4W	

Ref. No.	Part No.	Description	Remark
< VARIABLE RESISTOR >			
RV503	1-223-329-11	RES. VAR. CARBON 5K/5K (REC LEVEL)	
RV506	1-223-327-11	RES. VAR. CARBON 10K (BIAS)	
< SWITCH >			
S501	1-692-410-11	SWITCH, ROTARY (DOLBY NR)	
S502	1-554-118-00	SWITCH, PUSH (1 KEY) (MPX FILTER)	
S701	1-692-478-11	SWITCH, SLIDE (TIMER)	
S751	1-554-303-21	SWITCH, TACTILE (OPEN/CLOSE ☰)	
S752	1-554-303-21	SWITCH, TACTILE (■)	
S753	1-554-303-21	SWITCH, TACTILE (◀◀)	
S754	1-554-303-21	SWITCH, TACTILE (▶▶)	
S755	1-554-303-21	SWITCH, TACTILE (REC ●)	
S756	1-554-303-21	SWITCH, TACTILE (▷)	
S757	1-554-303-21	SWITCH, TACTILE (PAUSE)	
S758	1-554-303-21	SWITCH, TACTILE (REC MUTE ○)	
S759	1-554-303-21	SWITCH, TACTILE (COUNTER RESET)	
S760	1-554-303-21	SWITCH, TACTILE (COUNTER MEMORY)	
S762	1-554-303-21	SWITCH, TACTILE (MONITOR)	
S763	1-554-303-21	SWITCH, TACTILE (CALIBRATION)	
S801	1-692-409-11	SWITCH, PUSH (1 KEY) (POWER)	

*	1-632-741-11	REEL MOTOR BOARD	

< CAPACITOR >			
C1051	1-124-907-11	ELECT 10uF 20% 50V	
C1052	1-124-907-11	ELECT 10uF 20% 50V	
C1053	1-164-159-11	CERAMIC 0.1uF 50V	
< CONNECTOR >			
CN1051	1-564-501-11	PIN, CONNECTOR 8P	
* CN1052	1-564-720-11	PIN, CONNECTOR (SMALL TYPE) 4P	
* CN1053	1-564-718-11	PIN, CONNECTOR (SMALL TYPE) 2P	
< RESISTOR >			
R1051	1-247-825-31	CARBON 560 5% 1/4W	

Ref. No.	Part No.	Description	Remark
*	1-651-596-11	SENSOR BOARD *****	
		< CONNECTOR >	
* CN1004	1-564-496-11	PIN, CONNECTOR 3P < TRANSISTOR >	
Q1001	8-749-924-10	PHOTO REFLECTOR NJL5165K-B(H1) *****	
		MISCELLANEOUS *****	
16	1-534-517-00	WIRE, FLAT TYPE (11 CORE)	
17	1-765-149-11	WIRE (FLAT TYPE) (31 CORE)	
△57	1-551-188-XX	CORD, POWER (E)	
△57	1-558-945-21	CORD, POWER (POLAR. SPT-1) (US, Canadian)	
△61	1-696-845-11	CORD, POWER (AUS)	
△62	1-696-586-11	CORD, POWER (UK)	
△64	1-569-007-11	ADAPTOR, CONVERSION 2P (E)	
△65	1-575-651-21	CORD, POWER (AEP, G)	
D1051	8-719-980-85	DIODE SLF325C	
HE1001	1-543-673-11	HEAD, MAGNETIC (ERASE) (K715S)	
HE1001	1-543-836-11	HEAD, MAGNETIC (ERASE) (K717ES/K815S)	
HRP1001	1-543-733-11	HEAD, MAGNETIC (REC/PB) (K715S)	
HRP1001	1-543-834-11	HEAD, MAGNETIC (REC/PB) (K815S)	
HRP1001	1-543-835-11	HEAD, MAGNETIC (REC/PB) (K717ES)	
M1051	X-3356-638-1	MOTOR (REEL R) ASSY	
M1052	X-3356-604-1	MOTOR (ASSIST) ASSY	
M1053	X-3368-008-1	MOTOR (CAPSTAN V19) ASSY	
M1053	X-3368-029-1	MOTOR (CAPSTAN V18) ASSY	
△PT901	1-423-475-11	TRANSFORMER, POWER (US, Canadian)	
△PT901	1-423-476-11	TRANSFORMER, POWER (AEP, UK, G, AUS)	
△PT901	1-423-533-11	TRANSFORMER, POWER (E)	
S1001	1-466-238-11	ENCODER, ROTARY	
△VS1	1-692-155-11	SELECTOR, POWER VOLTAGE (VOLTAGE) (E)	

Ref. No.	Part No.	Description	Remark
***** HARDWARE LIST *****			
#1	7-621-255-20	SCREW +BVTT 2X4 (S)	
#2	7-621-255-35	SCREW +BVTT 2X5 (S)	
#3	7-621-770-67	SCREW +BVTT 2. 6X6 (S)	
#4	7-621-772-20	SCREW +B 2X5	
#5	7-621-772-70	SCREW +B 2X14 (K717ES/K815S)	
#6	7-621-775-20	SCREW +B 2. 6X5 (K717ES/K815S)	
#8	7-622-205-05	NUT M2 TYPE2 (K717ES/K815S)	
#9	7-628-253-00	SCREW +PS 2X4 (K717ES/K815S)	
#10	7-671-154-01	STENLESS BALL (K717ES/K815S)	
#11	7-682-547-09	SCREW +BVTT 3X6 (S)	
#12	7-682-548-09	SCREW +BVTT 3X8 (S)	
#13	7-682-647-01	SCREW +PS 3X6 (K717ES/K815S)	
#14	7-685-132-19	SCREW +BTP 2. 6X5 TYPE2 N-S (K715S)	
#15	7-685-533-19	SCREW +BTP 2. 6X6 TYPE2 N-S	
#16	7-685-534-19	SCREW +BTP 2. 6X8 TYPE2 N-S	
#17	7-685-646-79	SCREW +BVTP 3X8 TYPE2 N-S (E)	
#18	7-685-870-01	SCREW +BVTT 3X5 (S) (K717ES/K815S)	

ACCESSORIES & PACKING MATERIALS *****			
		1-558-271-11	CORD, CONNECTION
*		3-388-322-61	INDIVIDUAL CARTON (K717ES)
*		3-388-322-71	INDIVIDUAL CARTON (K815S)
*		3-388-322-81	INDIVIDUAL CARTON (K715S)
		3-758-196-11	MANUAL, INSTRUCTION (ENGLISH, FRENCH, SPANISH, PORTUGUESE) (K717ES:Canadian, E)
		3-758-196-21	MANUAL, INSTRUCTION (ENGLISH) (K717ES:US)
		3-758-197-11	MANUAL, INSTRUCTION (ENGLISH, FRENCH, SPANISH, PORTUGUESE) (K715S/K815S:AEP)
		3-758-197-41	MANUAL, INSTRUCTION (GERMAN, DUTCH, SWEDISH, ITALIAN) (K715S/K815S:AEP)
		3-758-197-51	MANUAL, INSTRUCTION (GERMAN) (K715S/K815S:G)
		3-758-197-61	MANUAL, INSTRUCTION (ENGLISH) (K715S:UK, AUS)
*		3-913-407-01	CUSHION

<p>The components identified by mark △ or dotted line with mark △ are critical for safety. Replace only with part number specified.</p>	<p>Les composants identifiés par une marque △ sont critiques pour la sécurité. Ne les remplacer que par une pièce portant le numéro spécifié.</p>
---	---

