

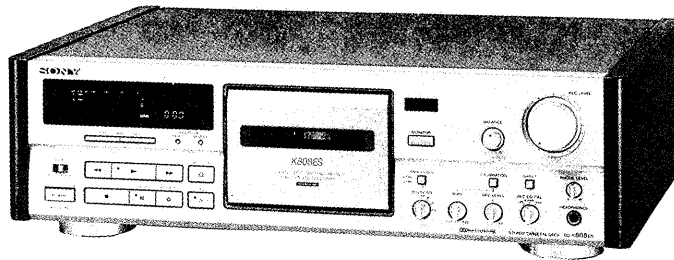

TC-K808ES

SERVICE MANUAL

AEP Model



Dolby noise reduction manufactured under license from Dolby Laboratories Licensing Corporation. "DOLBY" and the double-D symbol  are trademarks of Dolby Laboratories Licensing Corporation.

Model Name Using Similar Mechanism	TC-K222ESA/ TC-K890ES
Base Unit Name	TCM-200D14

SPECIFICATIONS

Recording system 4-track 2-channel stereo
 Fast winding time Approx. 90 sec. (with Sony C-60 cassette)
 Bias AC bias
 Heads Erasing head × 1 (S&F head)
 Recording head × 1 (SD head)
 Playback head × 1 (SD head)
 Motors Capstan motor × 1 (direct drive linear torque BSL motor)
 Reel motor × 1 (DC motor)
 Assist (mechanism drive) motor × 1 (DC motor)

Signal-to-noise ratio (at peak level and weighted)

Cassette (Dolby NR off)	Type IV	Type II	Type I
	61 dB	59 dB	57 dB

S/N ratio improvement (approximate values)

With Dolby B NR on: 5 dB at 1 kHz; 10 dB at 5 kHz
 With Dolby C NR on: 15 dB at 500 Hz; 20 dB at 1 kHz
 With Dolby S NR on: 10 dB at 100 Hz; 24 dB at 1 kHz

Harmonic distortion 0.4% (with Type I, 160 nWb/m, 315 Hz, 3rd H.D.)
 1.5% (with Type IV, 250 nWb/m, 315 Hz, 3rd H.D.)

Frequency response (Dolby NR off)

Type IV cassette	20 - 21,000 Hz (±3 dB, IEC) 20 - 16,000 Hz [±3 dB (-4 dB recording)]
Type II cassette	20 - 19,000 Hz (±3 dB, IEC)
Type I cassette	20 - 17,000 Hz (±3 dB, IEC)

Type IV : Sony METAL-S or ES-IV
 Type II : Sony UX-S or UX
 Type I : Sony HF-S

Wow and flutter ± 0.05% W.Peak (IEC)
 0.025% W.RMS (NAB)
 ± 0.07% W.Peak (DIN)

Inputs

Line inputs (phono jacks)	Sensitivity	0.16V
	Input impedance	47 k ohms

Outputs

Line outputs (phono jacks)	Rated output level	0.5 V at a load impedance of 47 k ohms
	Load impedance	Over 10 k ohms
Headphones (stereo phone jack)	Output level	0 - 3 mW at a load impedance of 32 ohms

General

Power requirements 220 - 230 V AC, 50/60 Hz
 Power consumption 26 W
 Dimensions Approx. 470 × 135 × 350 mm (w/h/d) including projecting parts and controls
 Mass Approx. 8.0 kg (17 lbs 11 oz)
 Supplied accessories Audio connecting cords (2)
 M3x8 screws (4)



Design and specifications are subject to change without notice.

STEREO CASSETTE DECK
SONY®

TABLE OF CONTENTS

<u>Section</u>	<u>Title</u>	<u>Page</u>
1. GENERAL	3
2. DISASSEMBLY		
	Cassette Holder	4
	Ornamental Plate	4
	Pinch Lever/Lever (FR2)	4
	Comparator Board/Capstan Board/Flywheel/FG Board	5
	MD Board	5
	Reel Motor Board	5
3. MECHANICAL ADJUSTMENTS	6
4. ELECTRICAL ADJUSTMENTS	9
5. DIAGRAMS		
	• IC Pin Assignment	13
	5-1. Semiconductor Lead Layouts	16
	5-2. Circuit Boards Location	16
	5-3. Block Diagram	17
	5-4. Printed Wiring Boards—Audio Section—	22
	5-5. Schematic Diagram —Audio Section—	25
	5-6. Schematic Diagram —System Control Section—	29
	5-7. Printed Wiring Boards—System Control Section—	33
	5-8. Schematic Diagram —DOLBY S Section—	37
6. EXPLODED VIEWS		
	6-1. Panel Section	39
	6-2. Chassis Section	40
	6-3. Mechanism Section-1	41
	6-4. Mechanism Section-2	42
7. ELECTRICAL PARTS LIST	43

SAFETY-RELATED COMPONENT WARNING!!

COMPONENTS IDENTIFIED BY MARK  OR DOTTED LINE WITH MARK  ON THE SCHEMATIC DIAGRAMS AND IN THE PARTS LIST ARE CRITICAL TO SAFE OPERATION. REPLACE THESE COMPONENTS WITH SONY PARTS WHOSE PART NUMBERS APPEAR AS SHOWN IN THIS MANUAL OR IN SUPPLEMENTS PUBLISHED BY SONY.

SECTION 1 GENERAL



Identifying the Parts

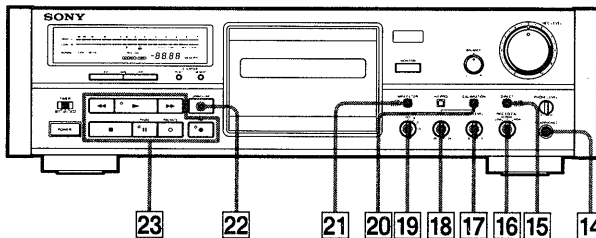
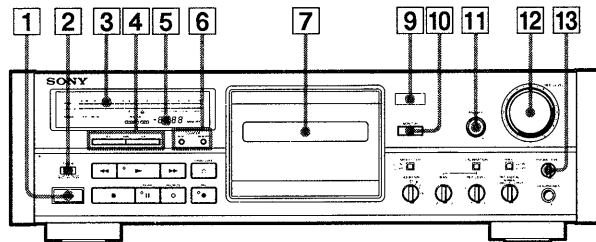







Front Panel



- 1 POWER switch
- 2 TIMER switch
- 3 Peak program meter
- 4 Automatic Music Sensor (AMS) buttons
- 5 Linear counter
- 6 COUNTER buttons
RESET button
MEMORY button
- 7 Cassette holder
- 9 Remote control sensor*
- 10 MONITOR button
- 11 BALANCE control
- 12 REC (recording) LEVEL control
- 13 PHONE (headphones) LEVEL control

* You can remotely control this cassette deck with:

- A remote commander that came with a Sony amplifier or receiver if it has the  mark and cassette deck control capability.
- An optional Sony remote commander with the  mark and cassette deck control capability.

- 14 HEADPHONES jack (stereo phone jack)
- 15 DIRECT button
- 16 REC EQ CAL (recording equalizing calibration) switch (LOW, NORMAL, HIGH)
- 17 REC (recording) LEVEL control for calibration
- 18 BIAS control
- 19 DOLBY NR (noise reduction) switch
- 20 CALIBRATION button
- 21 MPX FILTER button
- 22  OPEN/CLOSE button
- 23 Tape operation buttons and indicators
 -  (rewind) button
 -  (play) button and indicator
 -  (fast-forward) button
 -  (stop) button
 -  PAUSE button and indicator
 -  REC MUTE (record muting) button
 -  REC (recording) button and indicator

SECTION 2 DISASSEMBLY

NOTE: Follow the disassembly procedure in the numerical order given.

CASSETTE HOLDER

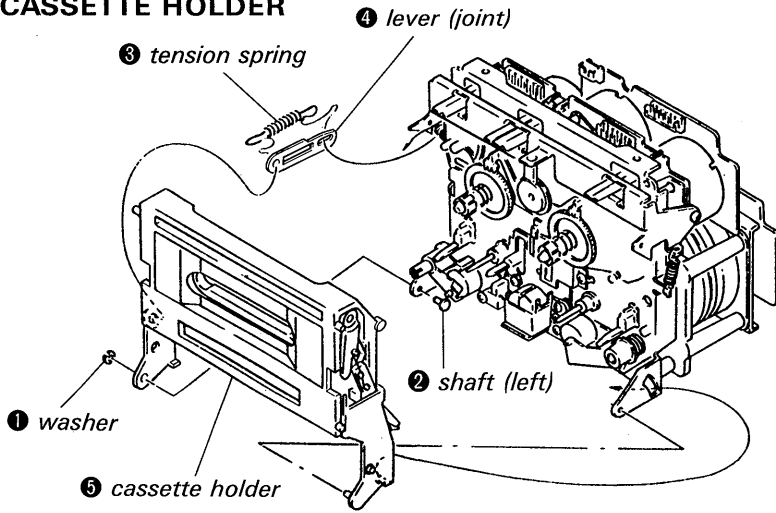

ORNAMENTAL PLATE

2 Push lever (lifter) in the direction of arrow and remove ornamental plate.

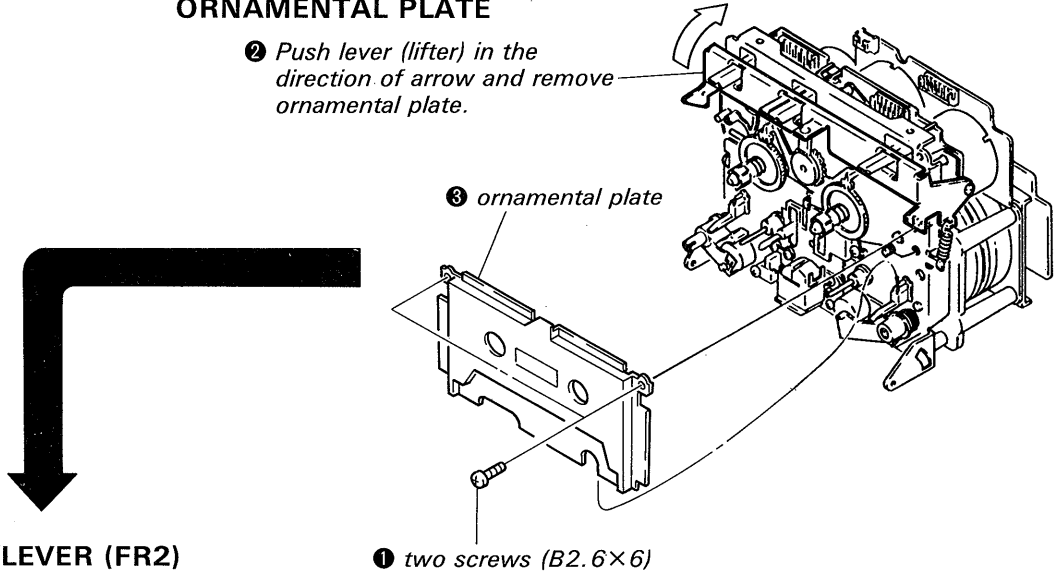

PINCH LEVER/LEVER (FR2)

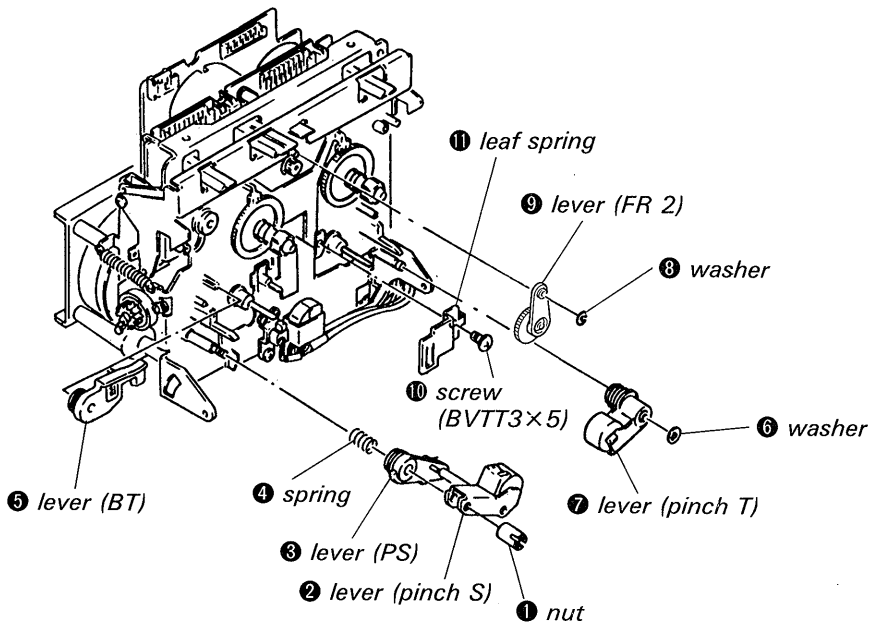

COMPARATOR BOARD/CAPSTAN BOARD/FLYWHEEL/FG BOARD

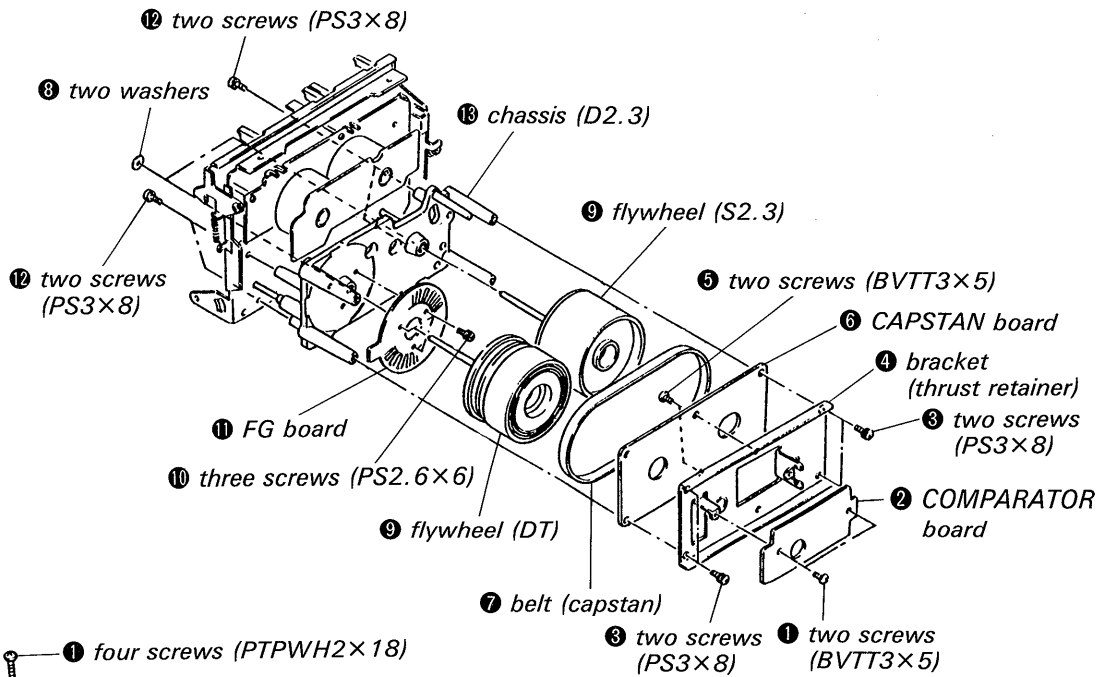

MD BOARD

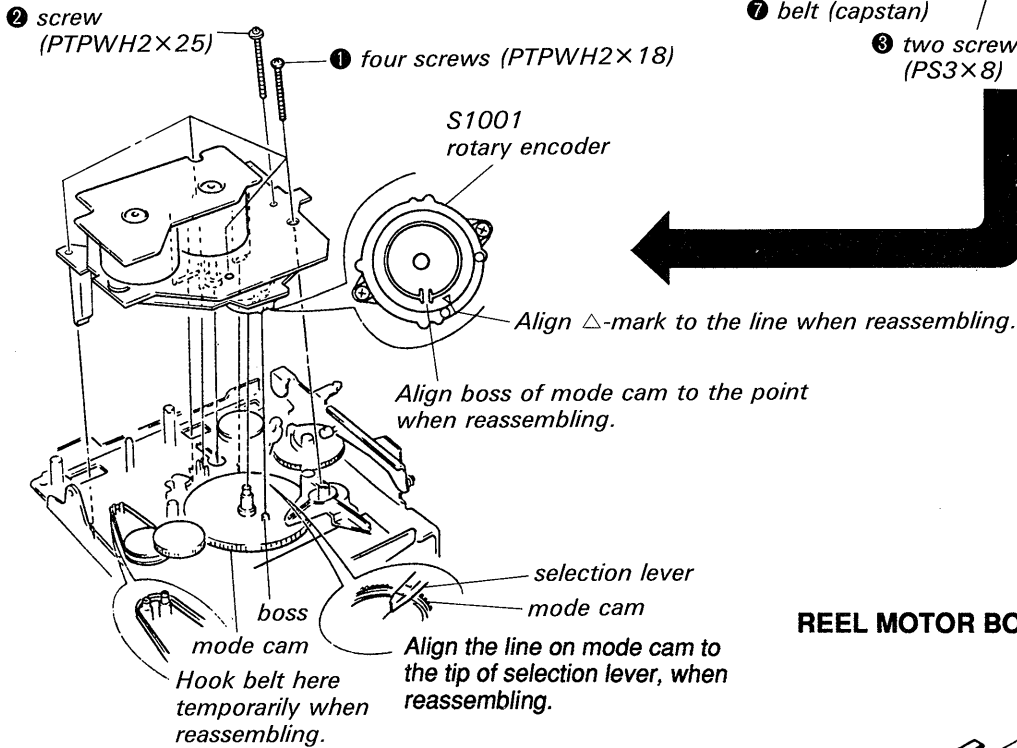

REEL MOTOR BOARD

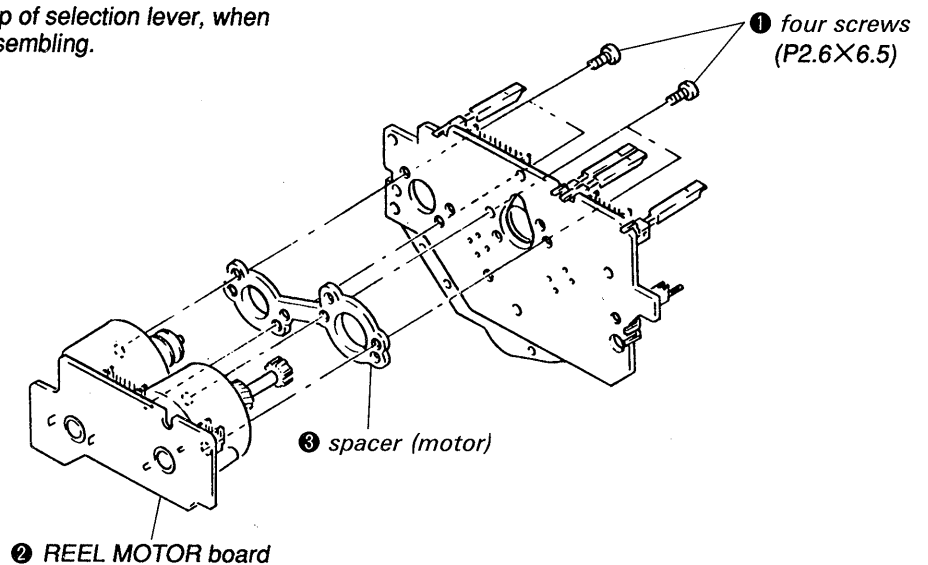

SECTION 3 MECHANICAL ADJUSTMENTS

- Refer to page 8 for Adjustment Location.

PRECAUTIONS

1. Clean the following parts with an alcohol-moistened swab.
(tape sliding surface)
2. Demagnetize the record/playback heads, erase heads and the capstan using the head demagnetizer.
3. Do not use a magnetized screw driver for the adjustments.
4. After the adjustments, apply suitable locking compound to the parts adjusted.
5. The adjustment should be performed with the rated power supply voltage unless otherwise noted.

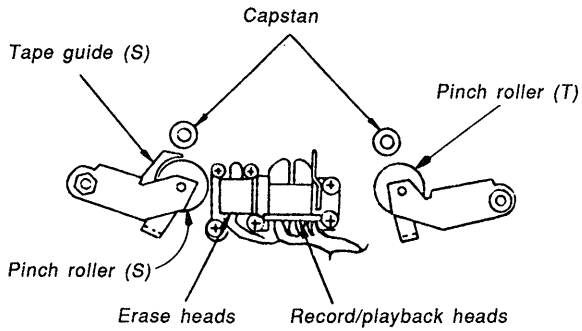

Tape Passing Adjustment

Note: For the following adjustments, use the jig as far as possible. Although the following methods are operable without using the jig, precise adjustment may not be completed, for example no compatibility to other decks is available even if self recording and playback is OK.

In these adjustments, either the pinch roller guide in the S side or the record/playback head guide is referred to for tape pass. Therefore, do not unnecessarily rotate the adjustment screws including those of the erase heads unless any one is replaced. When 2 or more heads or pinch rollers out of these 2 heads and pinch rollers are to be adjusted or replaced, use the jig for the adjustments or replace one at first and then take complete tape pass and then replace the second one.

Head height adjusting jig : apex

Preparation:

- Mirror cassette CQ009C 8-909-708-01
(Or CQ012C 8-909-708-02)

If it is not available, cut a part of the half of a 120 minute cassette tape and use.

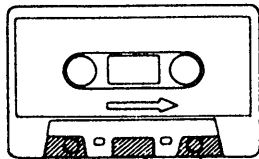

- Plus screw driver
Medium size Apply to the head adjusting screw.
Minus screw driver
Large size Apply to the pinch roller adjusting screw in the S side.
- Pen light
- WS-48B (3kHz, 0dB)
- P-4-A100 (10kHz, -10dB)

Definition:

The following view relates to record/playback heads.

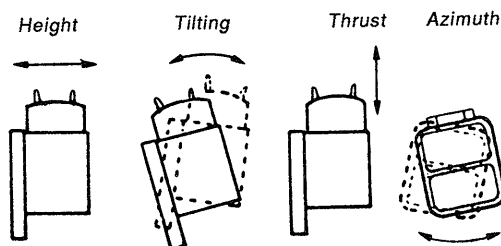

For the locations of the adjusting screws, see the view "adjustment location" in the lower right corner of Page 8.

Procedure:

Pinch roller in the S side

Note: It should be adjusted only when the pinch roller in the S side is replaced.

1. Mount the mirror cassette and set the equipment to playback state.
2. Check that the tape is curled in the pinch roller guide or the guide of the record/playback heads.

If curled, remedy it by rotating the tape curl adjusting screw **D**. At the time, check that the tape runs near the center part of the erase heads.

Record/playback heads

Note: The heads should be adjusted only when the record/playback head is replaced.

1. Mount the mirror cassette and set the equipment to playback state.
2. (Height adjustment) Check that the tape is curled in the tape guide of the heads. If curled, rotate screws **A**, **B** and **C** in the same angle and move the entire heads parallel. Check the mirror cassette where there is curling and, when curling exists in the lower side (actually in the deep side), tighten all screws slightly. If curled in the upper (your) side, loosen them.

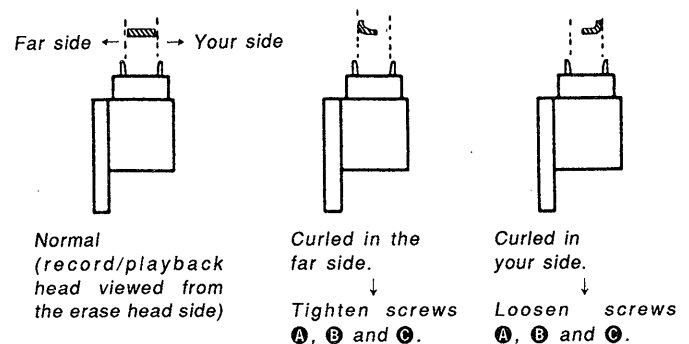

3. (Adjustment of tilting) Adjust back tension to 0 still in playback state (loosen the tape by rotating the reel in the S side using a small tip such as a pencil), and check that there is no curling or snaking (up or down) in the guide of the record/playback heads. Snaking of the tape may occur only within the range of a difference in the widths of the tape and the tape guide (it curls when tape slacks more than the range). Therefore, carefully check it because it may often be overlooked.

If the tape is snaking, rotate screws **B** and **C** in the same angle and change the tilting of the heads. Tighten or loosen the screws to remedy up or down snaking, respectively.

4. Repeat the adjustment 2 and 3 again and converge the height and tilting to suitable positions.
5. (Tentative adjustments of azimuth) Demagnetize and clean the heads and playback WS-48B (3kHz, 0dB). Rotate the screw **C** so that the pointer of the level meter of the set or connected to LINE OUT becomes maximum. If the screw is rotated more than 1/2 turn, repeat the adjustments again from 1.
6. (Checking of tape pass) Connect an oscilloscope to LINE OUT, replay P-4-A100 (10kHz, -10dB) to describe Lissajou's figures. At about 20 seconds after beginning playback (the tension in the loop becomes stable), check that the variation of the Lissajou's figures occur within $\pm 90^\circ$ (more preferably within $\pm 45^\circ$). If beyond $\pm 90^\circ$, adjustments of tilting or height will not be complete, so finely adjust the equipment again from 1.

Standard adjustment tape
P-4-A100
(10kHz, -10dB)

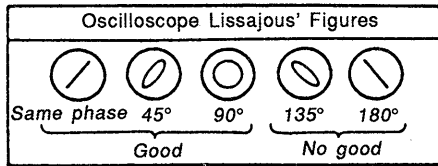
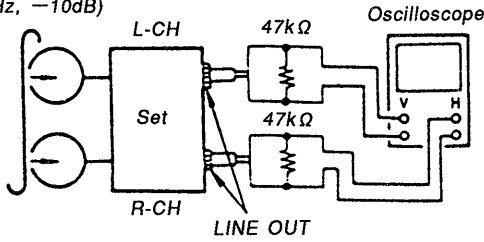

Erase heads

Note: The heads should be adjusted only when the erase head is replaced.

1. Mount the mirror cassette and set the equipment to playback state.
2. (Azimuth adjustments) Adjust screws **E** or **F** so that the tape runs as parallel to the erase heads as possible.

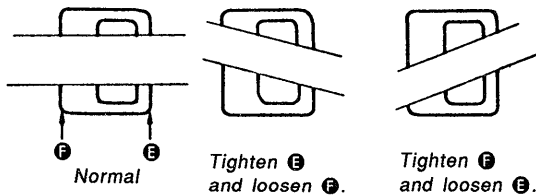

(Erase head viewed in the mirror cassette)

3. (Height adjustment) Rotate screws **D**, **E** and **F** in the same angle so that the widths of erase heads seen in the upper and lower sides of the tape become essentially the same. If the width in the upper or lower side is larger, tighten or loosen the screws, respectively.

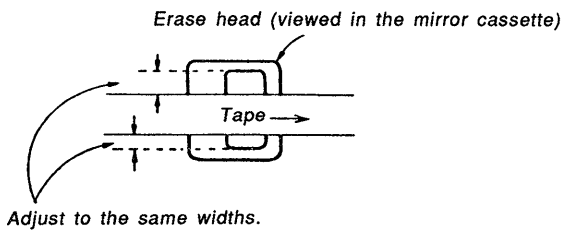

4. (Adjustments of tilting) Adjust back tension to 0 still in playback state and check that there is no snaking in the erase heads and pinch roller guide in the S side. If there is, change tilting by rotating the screw **D**. When the tape moves up or down in the mirror tape, tighten or loosen the screw, respectively.

5. Repeat the adjustments again from 2. and converge the height and tilting to more suitable values. And, check that there are no tape curls in the pinch roller guide and the guide of the record/playback heads.
6. (Adjustments of thrust) Slightly loosen the screw **G** and finely adjust it so that the tape smoothly runs over the entire surfaces of the heads by adjusting the thrust of the erase heads to an optimum value relative to the tape.

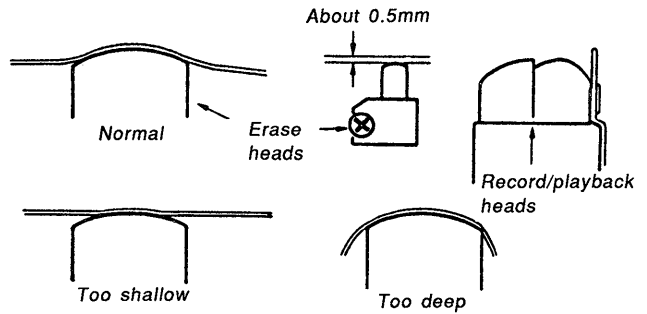

Checking

1. Check that the tape smoothly runs over the entire tape pass without curling or snaking.
2. After the adjustments, apply the locking compound to the screws adjusted (apply the compound to the screw **C** only after the final azimuth adjustments are completed).

Adjustment Location:

The following views relate to those in the mirror cassette (upper) and MD viewed from your side (lower).

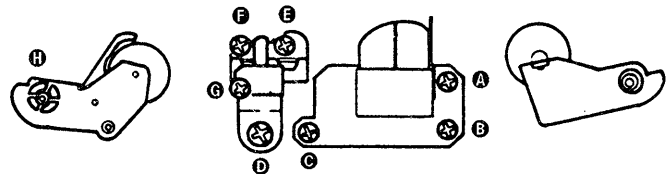
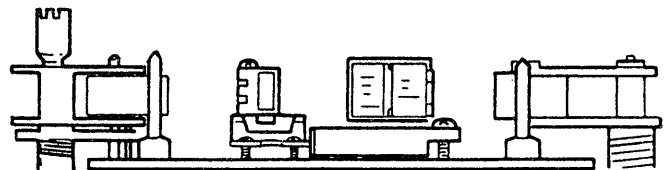

Pinch roller in the S side

Erase heads

Record/playback heads

Pinch roller in the T side

SECTION 4 ELECTRICAL ADJUSTMENTS

0dB=0.775V

1. Perform adjustment in the order listed below. (As a rule, adjust the record system after adjustment of playback system has been completed.)
2. Adjust and measure both channels unless otherwise specified.
3. To perform simultaneous record and playback, select recording mode, and set MONITOR switch to TAPE, then play back immediately the recorded signal to take out from LINE OUT.

• Switch position

DOLBY NR OFF
 MPX FILTER OFF
 TIMER OFF
 MONITOR TAPE
 CALIBRATION OFF
 DIRECT OFF
 BIAS CENTER CLICK
 REC LEVEL CENTER CLICK
 BALANCE CENTER CLICK

• Standard Record

Adjust the REC LEVEL (RV502) and BALANCE (RV501) controls so that the I/O signal levels specified below can be attained.

Record Mode

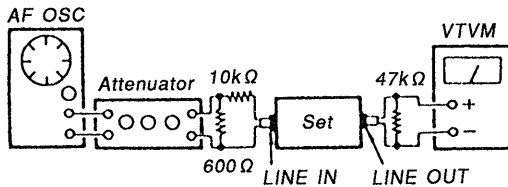

Standard Input Level

Input pin	LINE IN
Signal source impedance	10kΩ
Input signal level	0.25V (-10dB)

Standard Output Level

Output pin	LINE OUT
Load impedance	47kΩ
Output signal level	0.32V (-7.7dB)

Test tape

Type	Signal	Used for
WS-48B	3kHz, 0dB	Tape speed/WOW check
P-4-A100	10kHz, -10dB	Azimuth adjustment
P-4-L300	315Hz, 0dB	PB level adjustment

Torque Adjustment

1. Load the torque measuring tape CQ-102C, and play back. Adjust RV801 so that the torque meter reading is $40 \pm 5g \cdot cm$. (0.556 ± 0.069 oz·inch)
2. After adjustment, measure back tension and FF/REW torque, and make sure that measured data satisfies the specification.

Torque	Torque meter	Meter reading
FWD	CA-102C	35-45g·cm (0.49-0.62 oz·inch)
FWD back tension	CA-102C	7-11g·cm (0.10-0.15 oz·inch)
FF/REW	CQ-201B	65-90g·cm (0.91-1.25 oz·inch)

Tape Speed/WOW Check

Procedure:

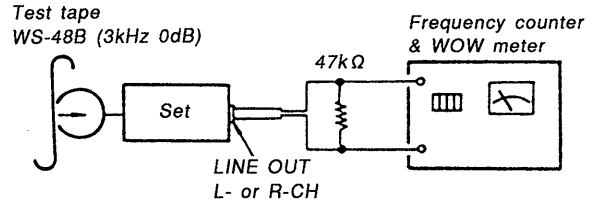

1. Play back the top of test tape to measure its output frequency and WOW value.
2. Invert test tape and perform same measurement, then check for difference between top and end of tape.

Specification:

Tape speed deviation : within 2,990~3,010Hz
 Tape speed fluctuation : within 2,990~3,010Hz
 WOW (WRMS) : 0.047% or less

MPX Filter Check

Condition:

DOLBY NR switch : OFF
 MPX FILTER switch : OFF

Procedure:

1. Mode : stop

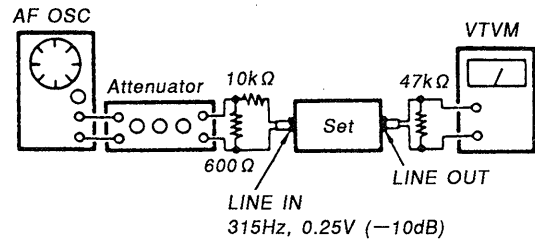

2. Applying 315Hz, 0.25V (-10dB) signal, adjust the REC LEVEL and BALANCE controls so that the LINE OUT level is 0.32V (-7.7dB).
3. Applying 19kHz, 0.25V (-10dB) signal, measure the LINE OUT level.

Specification:

DOLBY NR switch: Either B, C or S
 MPX FILTER switch: ON, LINE OUT level must be,
 315Hz: within 0.28~0.36V (within -8.7~-6.7dB)
 19kHz: 9.8mV (-38dB) or less

Record/Playback Head Azimuth Adjustment

Procedure:

1. Mode : FWD playback

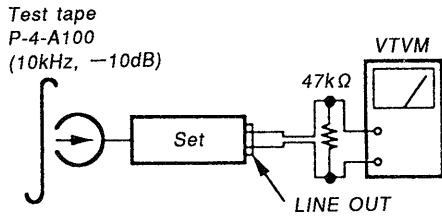

2. Turn the adjustment screw for the maximum output levels. If these levels do not match, turn the adjustment screw until both of output levels match together within 1dB.

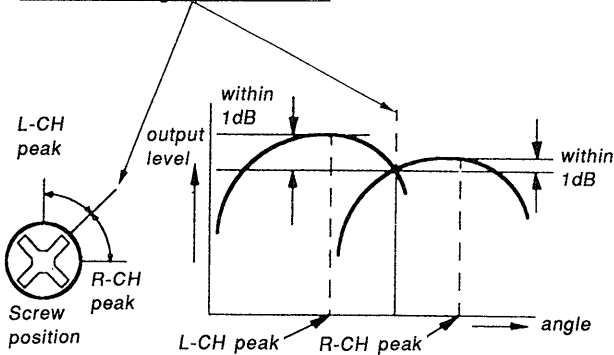

3. Phase Check
Mode: playback

Test tape
P-4-A100
(10kHz, -10dB)

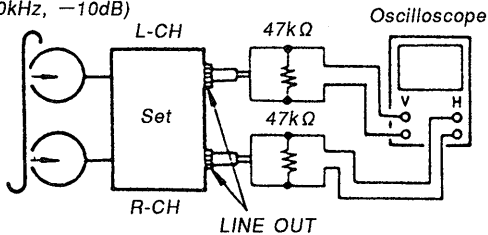

4. Confirm that the phase difference between L-CH and R-CH is in-phase to 90°.

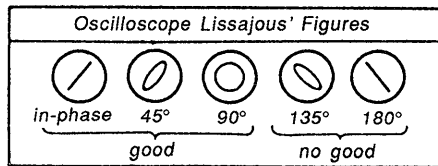

Adjustment Location:

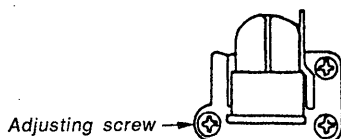

Playback Level Adjustment

Procedure:

1. Mode: playback

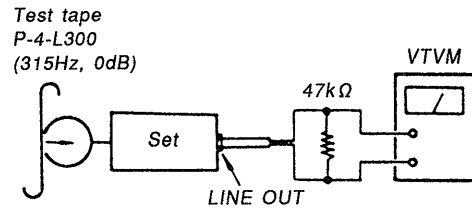

2. Adjust the RV101 (L-CH) and RV201 (R-CH) to satisfy the following specification.

Adjustment Value:

LINE OUT level : 302 — 338mV
(-8.2 — -7.2dB)

Level difference between channels: within 0.5dB

Confirm that the LINE OUT level does not change when playback and stop are repeated.

Erase Current Adjustment

Procedure:

1. Mode: record

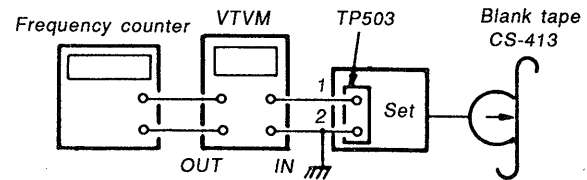

2. Adjust RV506 so that VTVM reading is 110mV (erase current 110mA).
3. At this time, confirm oscillation frequency.

Adjustment Value:

Erase current: 110 \pm 5 mA

Oscillation frequency: 160 \pm 6kHz

Bias Consumption Current Adjustment

Note: The bias consumption current must be adjusted before adjusting the record bias. Retry record bias adjustment after the bias consumption current is adjusted.

Procedure:

1. Set semi-fixed resistors RV104 (L-CH), RV204 (R-CH) and RV505 for record bias adjustment to mechanical center, and select the recording mode without applying a signal.
2. Adjust T101 (L-CH) and T201 (R-CH) so that the digital voltmeter reading becomes minimum.

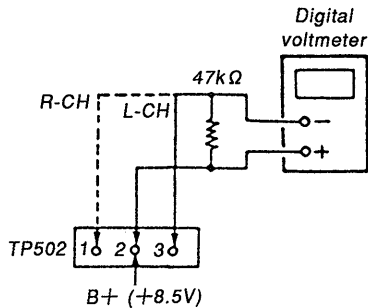

Specification: 120mV or less
(This value is measured using CS-413 after bias adjustment.)

Bias and Recording level adjustment

Condition:

REC LEVEL control: Specified recording position (Page 9)

Procedure:

1. Mode: simultaneous record and playback

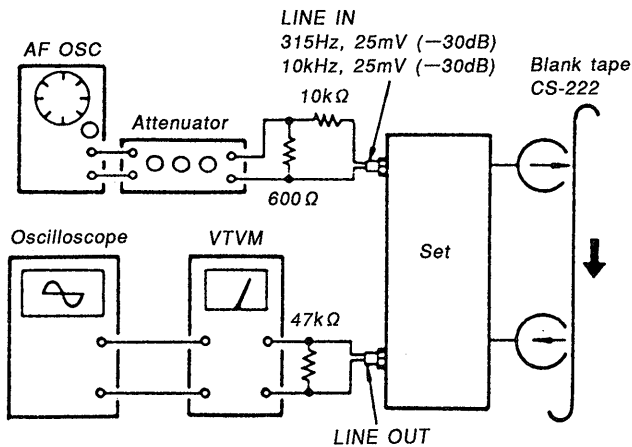

2. Adjust the following controls so that the minimum output becomes the specified output level.
 - (1) RV104 (L-CH) and RV204 (R-CH) Bias adjustment
 - (2) RV103 (L-CH) and RV203 (R-CH) Recording level adjustment

Adjustment Value:

- (1) Level of 10kHz against 315Hz: $0 \pm 0.3\text{dB}$
- (2) 315Hz level: 30.9 — 33.1mV (-28.0 — -27.4dB)

Metal Bias Adjustemnt

Condition:

REC LEVEL control: Specified recording position (page 9)

Procedure:

1. Mode: simultaneous record and playback

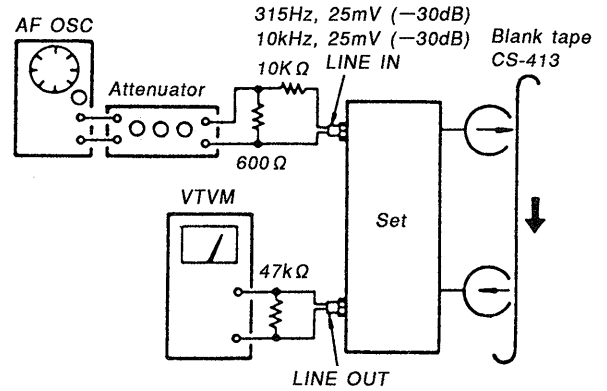

2. Adjust RV505 so that 10kHz R-CH output is $0 \pm 0.3\text{dB}$ relative to the 315Hz output.

Calibration Adjustment and Level Meter Adjustment

Condition:

CALIBRATION switch: ON

Procedure (oscillation output level adjustment):

1. Mode: record (No signal to LINE IN)

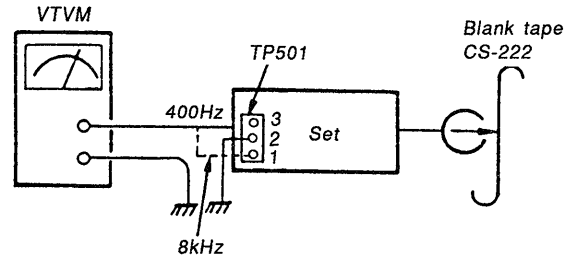

2. Adjust RV508 so that the 400Hz check point level is 2.32 — 2.59V (9.5dB—10.5dB).
3. Adjust RV507 so that the 8kHz check point level is 2.32 — 2.59V (9.5dB—10.5dB).

Procedure (level meter adjustment):

1. Record mode (No signal to LINE IN)
2. Adjust RV102 to higher side, then lower it gradually. Adjust so that the level "a" higher by one point than 0dB of LOW FREQ segment (lower) of CAL level meter turns off.
3. Adjust RV202 so that HIGH FREQ segment (upper) up to 0dB position of CAL level meter turns on.

HIGH: Blinking of level "a" higher by 1 point is acceptable.

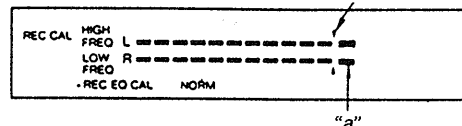

LOW: Blinking of level "a" higher by 1 point is not acceptable.

AUDIO (A) BOARD (component side)

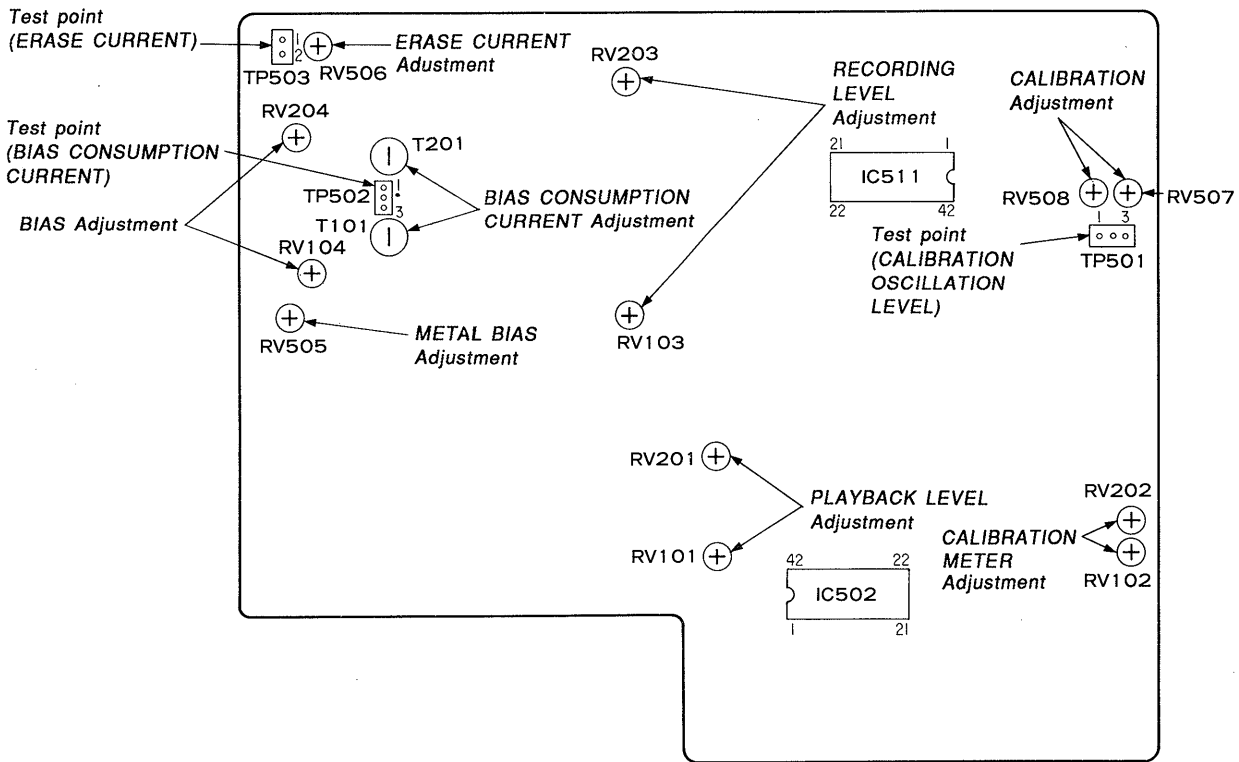

SYSTEM CONTROL (A) BOARD (component side)

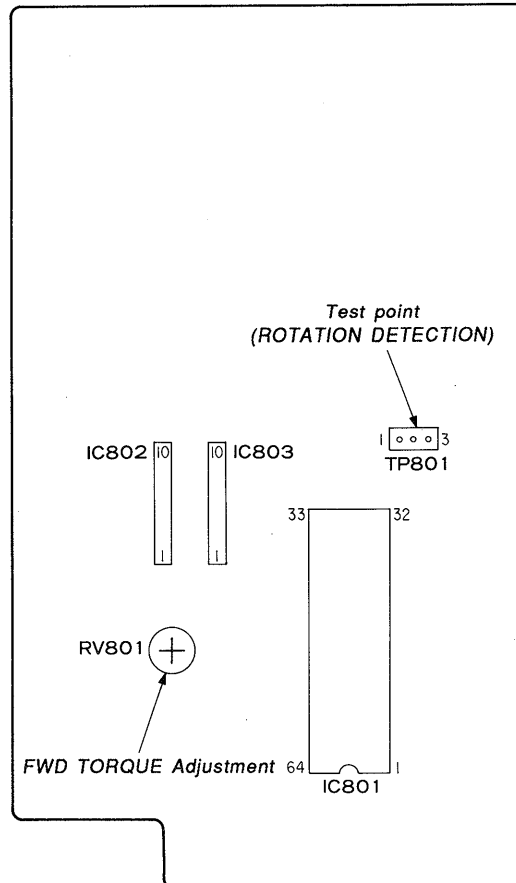

SECTION 5 DIAGRAMS

IC PIN ASSIGNMENT

IC801 Master Microcomputer (M50964-226SP)

This IC controls, based on input signals from various switches and remote devices, the mechanical deck, audio signal switching for equalizer, muting, etc. and data transfer to the display microcomputer.

Pin. No.	Pin Name	I/O	Function																																			
1	Vcc	—	Power supply (+5V)																																			
2	AVss	—	Power supply (GND)																																			
3	Vref	I	Reference voltage input (+5V) to A/D ports																																			
4	DATA	O	Data output (analog) to display microcomputer (IC601)																																			
5	PWM	—	Not used																																			
6	ADR0	O	Data output to display microcomputer (IC601)																																			
7	$\overline{\text{REC}}$	O	Not used (Connected to GND)																																			
8	$\overline{\text{PAUSE}}$	O	Not used (Connected to GND)																																			
9	$\overline{\text{PLAY}}$	O	Not used (Connected to GND)																																			
10	AD7	I	Key switch input (analog) 0V: "▲", 1V: "■", 2V: "◀", 3V: "▶", 4V: "●"																																			
11	AD6	I	Key switch input (analog) 0V: "▶", 1V: " ", 2V: "◀", 3V: "▶", 4V: "○"																																			
12	AD5	I	Key switch input (analog) 0V: "RESET", 1V: "MEMORY", 2V: "DISPLAY MODE"																																			
13	TIMER SW	I	Key switch input (analog) 3V: "REC", 4V: "PLAY", 5V: "OFF"																																			
14	T-PULSE	I	Mechanism deck take-up reel table sensor pulse input																																			
15	S-PULSE	I	Mechanism deck supply reel table sensor pulse input																																			
16	COUNT 0	I	Negative pulse input at counter 0																																			
17	—	—	Not used																																			
18	RSTOUT	O	Not used (Connected to GND)																																			
19	S-CLOCK	O	Not used (Connected to GND)																																			
20	S-OUT	O	Not used (Connected to GND)																																			
21	S-IN	I	Not used (Pull up)																																			
22	SIRCS-L	I	SIRCS signal (remote control) normal phase input																																			
23	$\overline{\text{SIRCS-E}}$	I	SIRCS signal (remote control) inverted phase input Inverted SIRCS-L input																																			
24	POW-OUT	O	Not used (Open)																																			
25	POWER IN	I	Power down detection input																																			
26	$\overline{\text{INT1}}$	I	Power down detection input																																			
27	CNVss	—	Power supply (GND)																																			
28	RESET	I	RESET input																																			
29	XIN	I	Clock input (4MHz)																																			
30	XOUT	O	Clock output (4MHz)																																			
31	ϕ	—	Not used																																			
32	Vss	—	Power supply (GND)																																			
33~36	$\overline{\text{PAT3}} \sim \overline{\text{PAT0}}$	I	Rotary encoder input for mechanism deck head base position detection <table border="1" style="margin-left: auto; margin-right: auto;"> <thead> <tr> <th></th> <th>PAUSE</th> <th>AMS</th> <th>FF/REW</th> <th>STOP</th> <th>PLAY</th> <th>EJECT</th> </tr> </thead> <tbody> <tr> <td>$\overline{\text{PAT3}}$</td> <td>L</td> <td>L</td> <td>L</td> <td>L</td> <td>H</td> <td>H</td> </tr> <tr> <td>$\overline{\text{PAT2}}$</td> <td>L</td> <td>L</td> <td>H</td> <td>H</td> <td>L</td> <td>L</td> </tr> <tr> <td>$\overline{\text{PAT1}}$</td> <td>L</td> <td>H</td> <td>L</td> <td>H</td> <td>L</td> <td>H</td> </tr> <tr> <td>$\overline{\text{PAT0}}$</td> <td>L</td> <td>H</td> <td>H</td> <td>L</td> <td>L</td> <td>L</td> </tr> </tbody> </table>		PAUSE	AMS	FF/REW	STOP	PLAY	EJECT	$\overline{\text{PAT3}}$	L	L	L	L	H	H	$\overline{\text{PAT2}}$	L	L	H	H	L	L	$\overline{\text{PAT1}}$	L	H	L	H	L	H	$\overline{\text{PAT0}}$	L	H	H	L	L	L
	PAUSE	AMS	FF/REW	STOP	PLAY	EJECT																																
$\overline{\text{PAT3}}$	L	L	L	L	H	H																																
$\overline{\text{PAT2}}$	L	L	H	H	L	L																																
$\overline{\text{PAT1}}$	L	H	L	H	L	H																																
$\overline{\text{PAT0}}$	L	H	H	L	L	L																																
37	$\overline{\text{OPEN SW}}$	I	Mechanism deck OPEN SW (S1004) input "L": Cassette holder is opened																																			
38	$\overline{\text{CLOSE SW}}$	I	Mechanism deck CLOSE SW (S1003) input "L": Cassette holder is closed																																			

Pin. No.	Pin Name	I/O	Function															
39	$\overline{\text{DOOR SW}}$	I	Mechanism deck DOOR SW (S1002) input "L": Cassette holder status changes from open to close															
40	$\overline{\text{REC SW}}$	I	Mechanism deck REC SW (S1001) input "L": REC protector is broken															
41	$70\mu\text{ SW}$	I	Mechanism deck $70\mu\text{ SW}$ (S1008) input "H": $70\mu\text{ S}$, "L": $120\mu\text{ S}$ (constant when playback EQ)															
42	$\overline{\text{HALF SW}}$	I	Mechanism deck HALF SW (S1006) input "L": Tape is loaded															
43	$\overline{\text{METAL SW}}$	I	Mechanism deck METAL SW (S1007) input "H": Metal tape, "L": Normal or CrO ₂ tape															
44	—	—	Not used															
45	$\overline{\text{CAM UP}}$	O	Mechanism deck head base UP output															
46	$\overline{\text{CAM DOWN}}$	O	Mechanism deck head base DOWN output <table border="1" style="margin-left: 20px;"> <thead> <tr> <th></th> <th>STOP</th> <th>DOWN</th> <th>UP</th> <th>STOP</th> </tr> </thead> <tbody> <tr> <td>$\overline{\text{CAM UP}}$</td> <td>L</td> <td>H</td> <td>L</td> <td>H</td> </tr> <tr> <td>$\overline{\text{CAM DOWN}}$</td> <td>L</td> <td>L</td> <td>H</td> <td>H</td> </tr> </tbody> </table>		STOP	DOWN	UP	STOP	$\overline{\text{CAM UP}}$	L	H	L	H	$\overline{\text{CAM DOWN}}$	L	L	H	H
	STOP	DOWN	UP	STOP														
$\overline{\text{CAM UP}}$	L	H	L	H														
$\overline{\text{CAM DOWN}}$	L	L	H	H														
47	$\overline{\text{M-FWD}}$	O	Reel motor forward run															
48	$\overline{\text{M-REV}}$	O	Reel motor reverse run <table border="1" style="margin-left: 20px;"> <thead> <tr> <th></th> <th>STOP</th> <th>FWD/ CLOSE</th> <th>REV/ OPEN</th> <th>BRAKE</th> </tr> </thead> <tbody> <tr> <td>$\overline{\text{M-FWD}}$</td> <td>L</td> <td>L</td> <td>H</td> <td>H</td> </tr> <tr> <td>$\overline{\text{M-REV}}$</td> <td>L</td> <td>H</td> <td>L</td> <td>H</td> </tr> </tbody> </table>		STOP	FWD/ CLOSE	REV/ OPEN	BRAKE	$\overline{\text{M-FWD}}$	L	L	H	H	$\overline{\text{M-REV}}$	L	H	L	H
	STOP	FWD/ CLOSE	REV/ OPEN	BRAKE														
$\overline{\text{M-FWD}}$	L	L	H	H														
$\overline{\text{M-REV}}$	L	H	L	H														
49	$\overline{\text{M-PLAY}}$	O	"L" when reel motor runs at PLAY speed															
50	$\overline{\text{M-FAST}}$	O	"L" when reel motor runs at FF/REW speed															
51	$\overline{\text{BIAS}}$	O	Bias oscillation control output "L": Oscillation, "H": OFF															
52	$\overline{\text{REC MUTE}}$	O	REC mute control output "H": Mute															
53	$\overline{\text{MONITER}}$	O	Monitor switch output "H": TAPE, "L": SOURCE															
54	$\overline{\text{LINE MUTE}}$	O	Line mute control output "H": Mute															
55	—	—	Not used (Connected to $\overline{\text{AMS MODE}}$)															
56	$\overline{\text{AMS MODE}}$	O	AMS switch output "L": AMS															
57	$\overline{\text{TYPE I}}$	O	REC equalizer switching output "L": Normal tape															
58	$\overline{\text{TYPE II}}$	O	REC equalizer switching output "L": CrO ₂ tape															
59	$\overline{\text{TYPE IV}}$	O	REC equalizer switching output "L": Metal tape															
60	$\overline{\text{AMS SIG}}$	I	AMS signal input "L": No music "H": Music															
61	$\overline{\text{SOURCE SW}}$	I	Not used (Connected to +5V)															
62	$\overline{\text{TAPE SW}}$	I	Not used (Connected to +5V)															
63	$\overline{\text{CAL SW}}$	I	Calibration SW (S602) input "L": CAL mode, "H": Normal mode															
64	ADDR1	O	Data output to display microcomputer (IC601)															

IC601 Display Microcomputer (M50940-313SP)

This IC controls display of 24-segment level meter, counter, etc. based on the instruction from master microcomputer (IC801).

Pin. No.	Pin Name	I/O	Function
1	Vref	I	Reference voltage input (+5V) to A/D ports
2	ϕ L	I	Mechanism deck supply reel table sensor pulse input
3	ϕ R	I	Mechanism deck take-up reel table sensor pulse input
4	DATA	I	Data input (analog) from master microcomputer (IC801)
5~6	ADR1~ADR0	I	Data input (analog) from master microcomputer (IC801)
7	KEY	I	Key switch input (analog) 0V : MEMORY 1.6V : RESET 3.1V : DISPLAY
8	LEVEL L	I	Level meter Lch input (analog) from meter amplifier (IC507)
9	LEVEL R	I	Level meter Rch input (analog) from meter amplifier (IC507)
10~15	$\overline{\text{GRID6}} \sim \overline{\text{GRID1}}$	O	FL tube grid output
16	$\overline{\text{C00}}$	O	Negative pulse output when counter is 00
17	$\overline{\text{PLAY}}$	O	PLAY LED output "L" : ON
18	$\overline{\text{PLAY}}$	O	PLAY LED output "L" : ON
19	$\overline{\text{PAUSE}}$	O	PAUSE LED output "L" : ON
20	$\overline{\text{REC}}$	O	REC LED output "L" : ON
21	$\overline{\text{TAPE}}$	O	FL tube segment output (L : TAPE, H : SOURCE display)
22	$\overline{\text{OVER LEVEL}}$	O	FL tube segment output ("OVER LEVEL" display)
23	$\overline{\text{TYPE I}}$	O	FL tube segment output ("TYPE I" display)
24	$\overline{\text{TYPE II}}$	O	FL tube segment output ("TYPE II" display)
25	$\overline{\text{TYPE IV}}$	O	FL tube segment output ("TYPE IV" display)
26	CNVss	-	Power supply (GND)
27	$\overline{\text{RESET}}$	I	RESET input
28	XIN	I	Clock input (4MHz)
29	XOUT	O	Clock output (4MHz)
30	XCIN	-	Not used (Normally "L")
31	XCOU	-	Not used
32	Vss	-	Power supply (GND)
33	ϕ	O	Not used
34	VER	I	Version switching input (Normally "L")
35	$\overline{\text{TEST}}$	I	TEST mode input "L" : Meter all ON
36	CAL	I	Calibration SW (S602) input "L" : CAL mode, "H" : Normal mode
37	IN	I	Not used
38	VP	I	Pull down power supply (-22V) for FL tube segment output
39~62	S23~S0	O	FL tube segment output (meter, counter display)
63	AVcc	-	Power supply (+5V)
64	Vcc	-	Power supply (+5V)

5-1. SEMICONDUCTOR LEAD LAYOUTS

**BA6219B
LB1641**

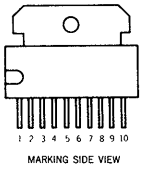

M5218AL

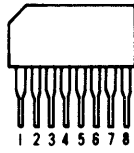

**2SB1094-LK
2SD1406-YGR
2SD1585-LK
2SD2012**

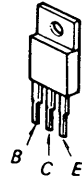

**2SK246-GR
2SK30A-GR2**

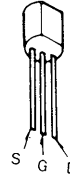

**SEL2210S-D
SEL2410E-D
SEL2910A-D**

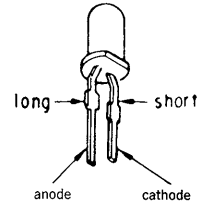

CXA1417Q

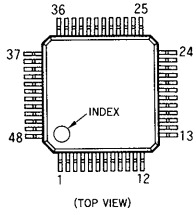

2SA1175-HFE

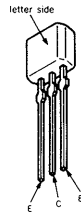

**2SC1815-Y
2SC2603-EF
2SD2144S-UVW
DTA114ES
DTA144ES
DTC114ES
DTC144ES**

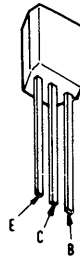

**10E2N
1N4148M
30DF2**

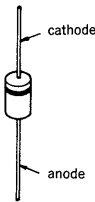

GP2S22B

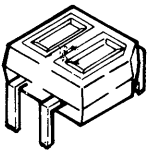

**2SA1409-LK
2SB1116A-L
2SC945-P**

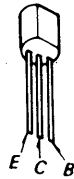

**HZS6C3L
UZL-12H1
UZL-6L3**

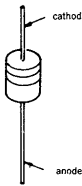

5-2. CIRCUIT BOARDS LOCATION

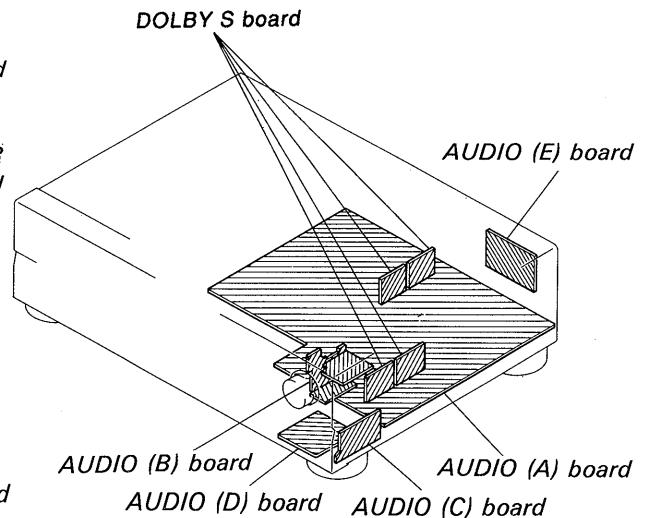
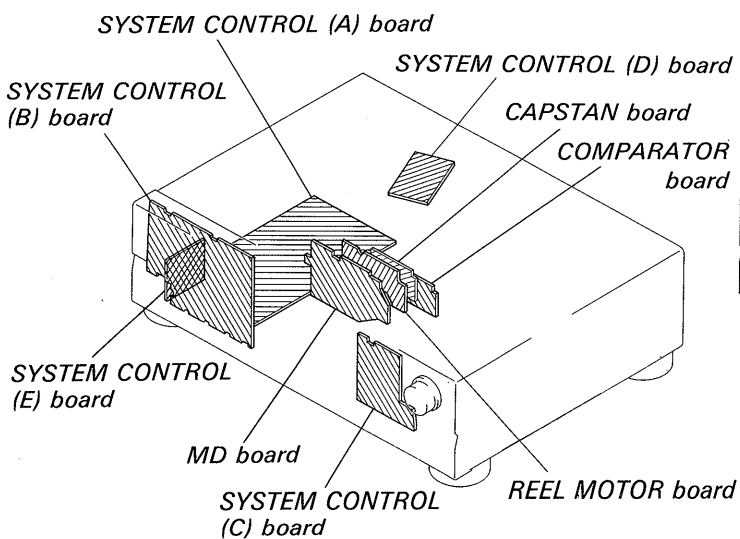

5-3. BLOCK DIAGRAM

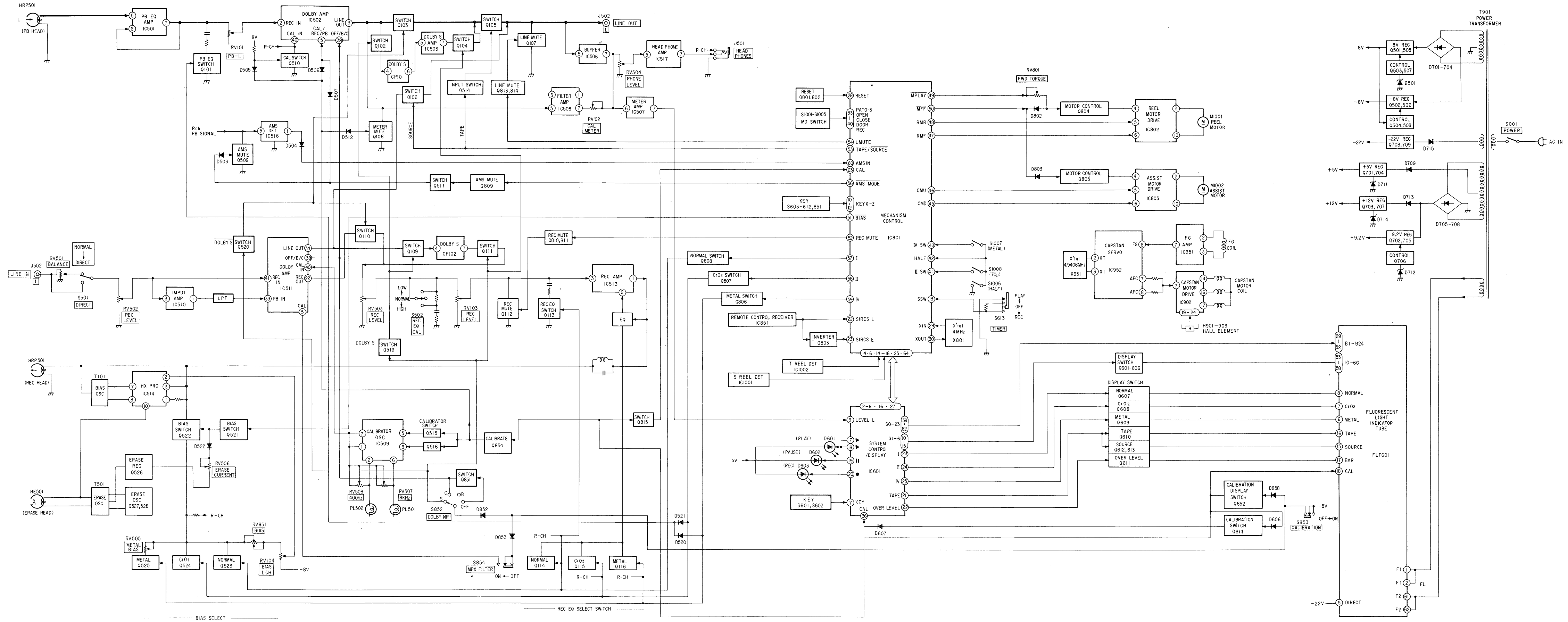

• Semiconductor Location

Ref. No.	Location	Ref. No.	Location	Ref. No.	Location
D101	J-7	IC1	C-21	Q212	C-12
D102	J-7	IC2	G-20	Q213	C-13
D103	G-6	IC501	H-13	Q214	C-13
D104	G-7	IC502	I-10	Q215	C-13
D105	D-6	IC503	I-7	Q216	C-13
D106	E-6	IC506	F-8	Q501	H-15
D107	E-6	IC507	E-6	Q502	G-15
D108	D-12	IC508	J-6	Q503	I-16
D109	E-12	IC509	B-7	Q504	G-16
D201	G-7	IC510	C-7	Q505	H-16
D202	G-7	IC511	C-9	Q506	G-16
D203	G-8	IC513	D-14	Q507	H-16
D204	G-7	IC514	D-16	Q508	G-16
D205	D-6	IC516	F-10	Q509	G-12
D206	E-7	IC517	J-3	Q510	G-12
D207	E-7			Q511	F-13
D208	C-12	Q101	H-12	Q514	F-8
D209	B-12	Q102	J-8	Q515	C-6
D501	H-16	Q103	I-7	Q516	C-7
D503	F-13	Q104	I-7	Q519	E-10
D504	F-9	Q105	G-6	Q520	E-10
D505	G-11	Q106	G-7	Q521	D-17
D506	G-11	Q107	F-7	Q522	D-17
D507	G-11	Q108	J-7	Q523	E-16
D508	J-8	Q109	E-11	Q524	E-16
D509	J-8	Q110	D-12	Q525	E-16
D510	H-8	Q111	E-12	Q526	B-16
D511	H-8	Q112	E-13	Q527	B-16
D512	F-8	Q113	D-13	Q528	B-15
D513	E-8	Q114	D-13		
D514	C-12	Q115	D-13		
D515	C-12	Q116	D-13		
D516	E-12	Q201	G-12		
D517	E-12	Q202	H-8		
D518	E-11	Q203	H-7		
D519	E-10	Q204	G-7		
D520	F-13	Q205	G-7		
D521	F-13	Q206	G-7		
D522	B-16	Q207	F-7		
D523	J-8	Q208	G-7		
D524	H-8	Q209	C-11		
D525	C-12	Q210	D-12		
D526	E-12	Q211	B-12		

Note:

- : parts extracted from the component side.
- : parts mounted on the conductor side.
- (with dot) : Through hole.
- ▨ : Pattern from the side which enables seeing. (The other layers' patterns are not indicated.)

Caution:

Pattern face side: Parts on the pattern face side seen from (Conductor Side) the pattern face are indicated.

Parts face side: Parts on the parts face side seen from the (Component Side) parts face are indicated.

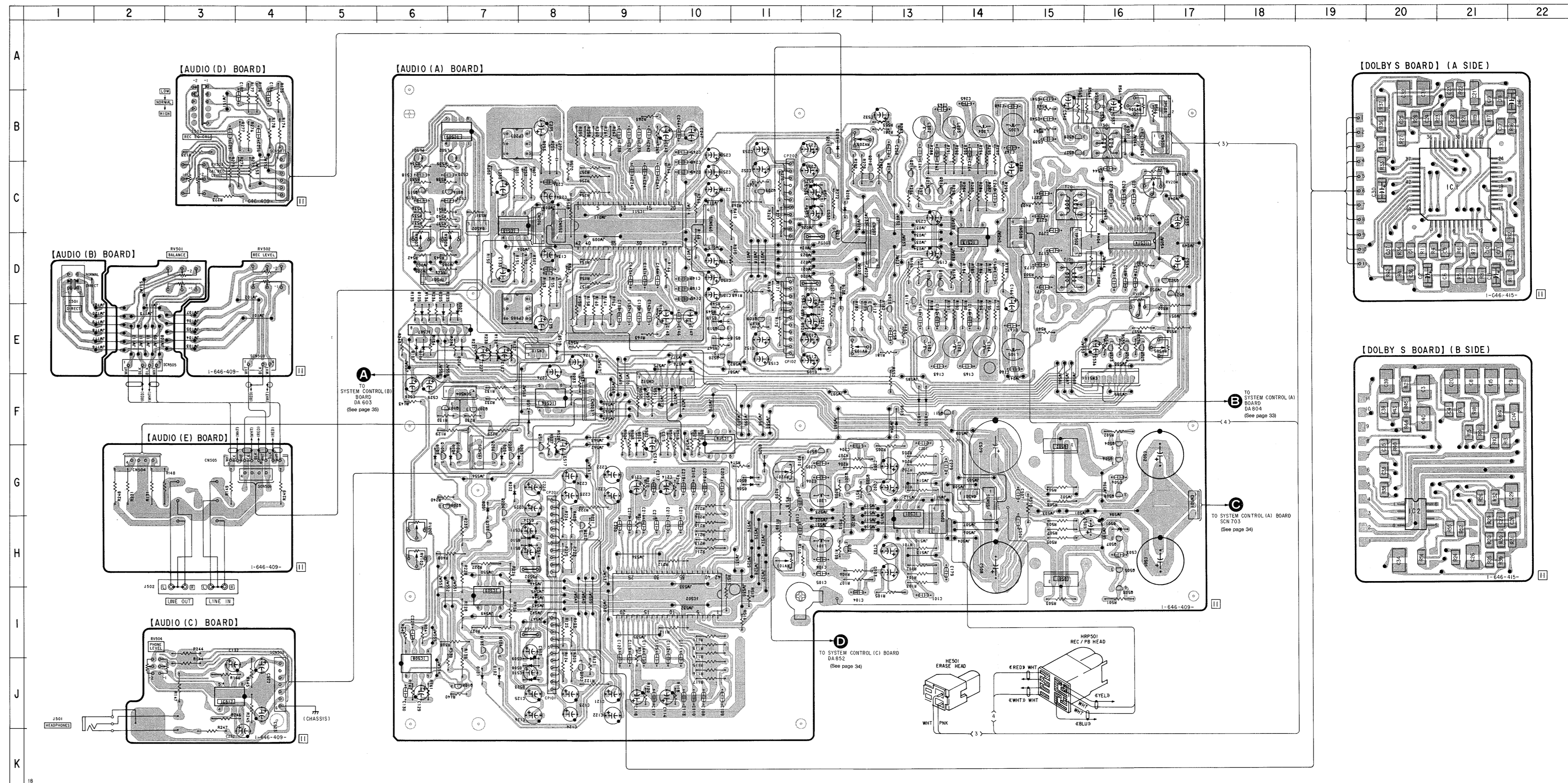

5-5. SCHEMATIC DIAGRAM —AUDIO Section—

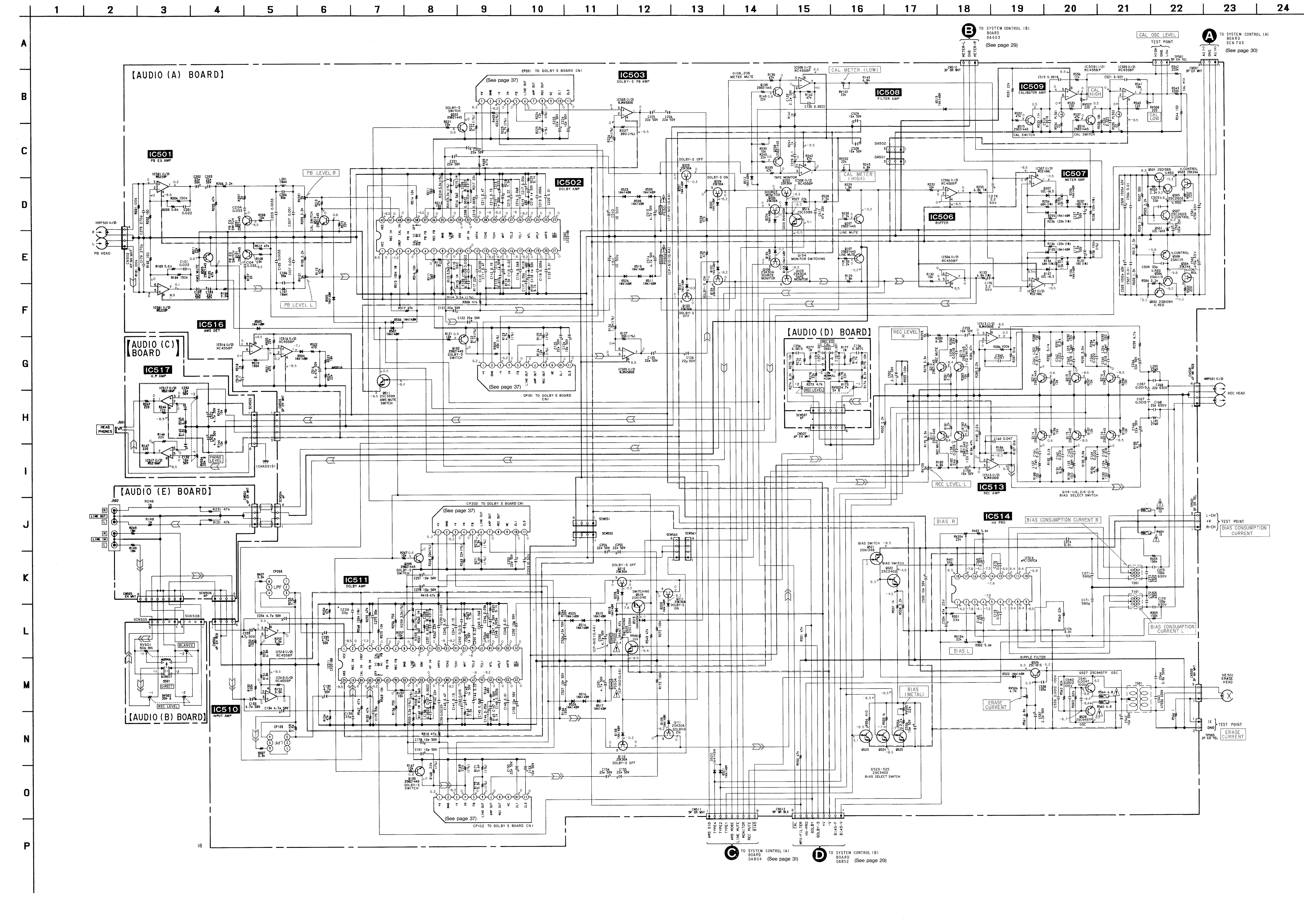

IC Block Diagrams

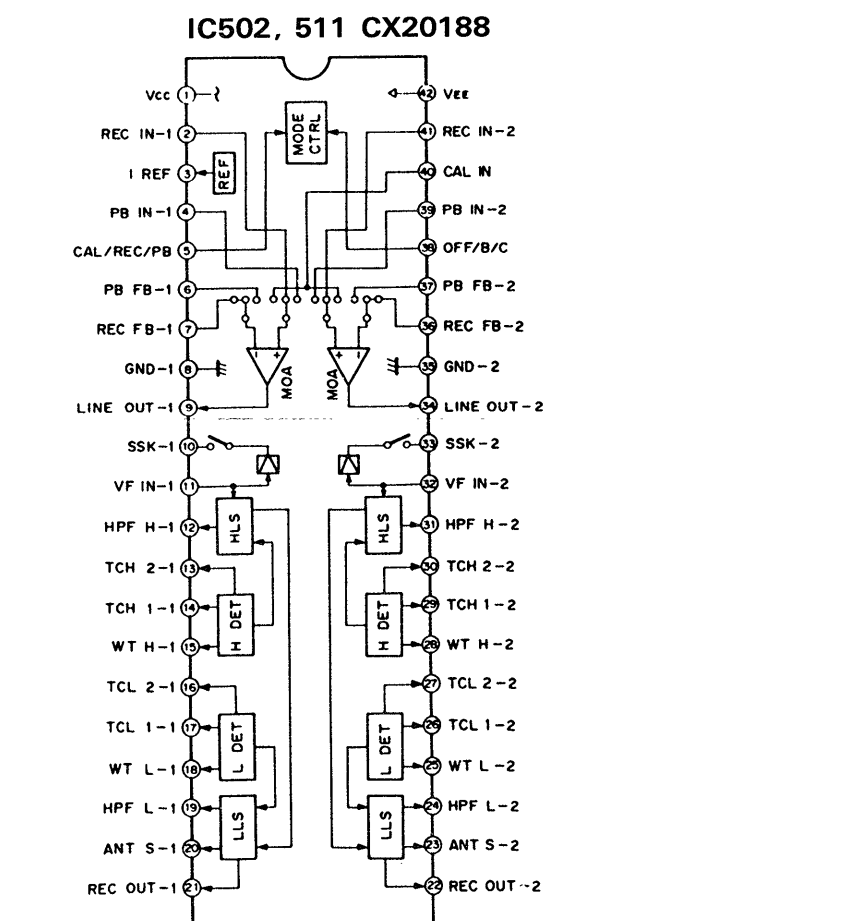
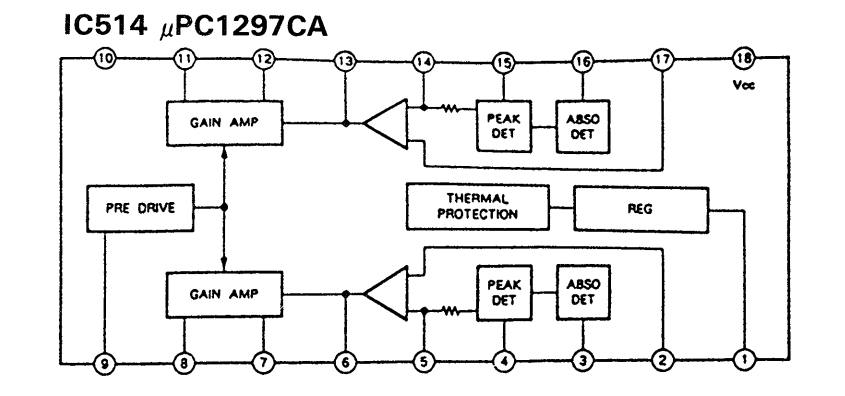

Pin No.	Pin Name	Function
1	Vcc	Positive power supply
2, 41	REC IN	REC input
3	I REF	Reference current input
4, 39	PB IN	PLAYBACK input
5	CAL/REC/PB	CALIBRATION/REC/PLAYBACK switching
6, 37	PB FB	PLAYBACK feedback
7, 36	REC FB	REC feedback
8, 35	GND	GND in 2-power mode, Vcc/2 in 1-power mode
9, 34	LINE OUT	Line out (decode output)
10, 33	SSK	Spectral skewing switch
11, 32	VF IN	Encode circuit input
12, 31	HPF H	HLS high pass filter
13, 30	TCH 2	HLS detector time constant 2
14, 29	TCH 1	HLS detector time constant 1
15, 28	WT H	HLS weighting
16, 27	TCL 2	LLS detector time constant 2
17, 26	TCL 1	LLS detector time constant 1
18, 25	WT L	LLS weighting
19, 24	HPF L	LLS high pass filter
20, 23	ANT S	Anti-saturation
21, 22	REC OUT	REC output (encode output)
38	OFF/B/C	DOLBY NR OFF/B type/C type switching
40	CAL IN	CALIBRATION input
42	Vss	Negative power supply in 2-power mode, GND in 1-power mode

Notes:

- All capacitors are in μF unless otherwise noted. pF: μF 50WV or less are not indicated except for electrolytics and tantalums.
- All resistors are in Ω and $\frac{1}{2}\text{W}$ or less unless otherwise specified.
- % : indicates tolerance.
- Δ : internal component.
- \square : nonflammable resistor.
- --- : fusible resistor.

Note:
The components identified by mark Δ or dotted line with mark Δ are critical for safety. Replace only with part number specified.

- --- : B+ Line
- --- : B- Line
- --- : adjustment for repair.
- --- : Voltage is dc with respect to ground under no-signal conditions.
- Voltagages are taken with a VOM (Input Impedance $10\text{M}\Omega$). Voltage variations may be noted due to normal production tolerances.
- Signal path.
- --- : PB
- --- : REC

5-6. SCHEMATIC DIAGRAM—SYSTEM CONTROL Section—

1 2 3 4 5 6 7 8 9 10 11 12 13 14 15 16 17 18 19 20 21 22 23 24 25 26 27 28

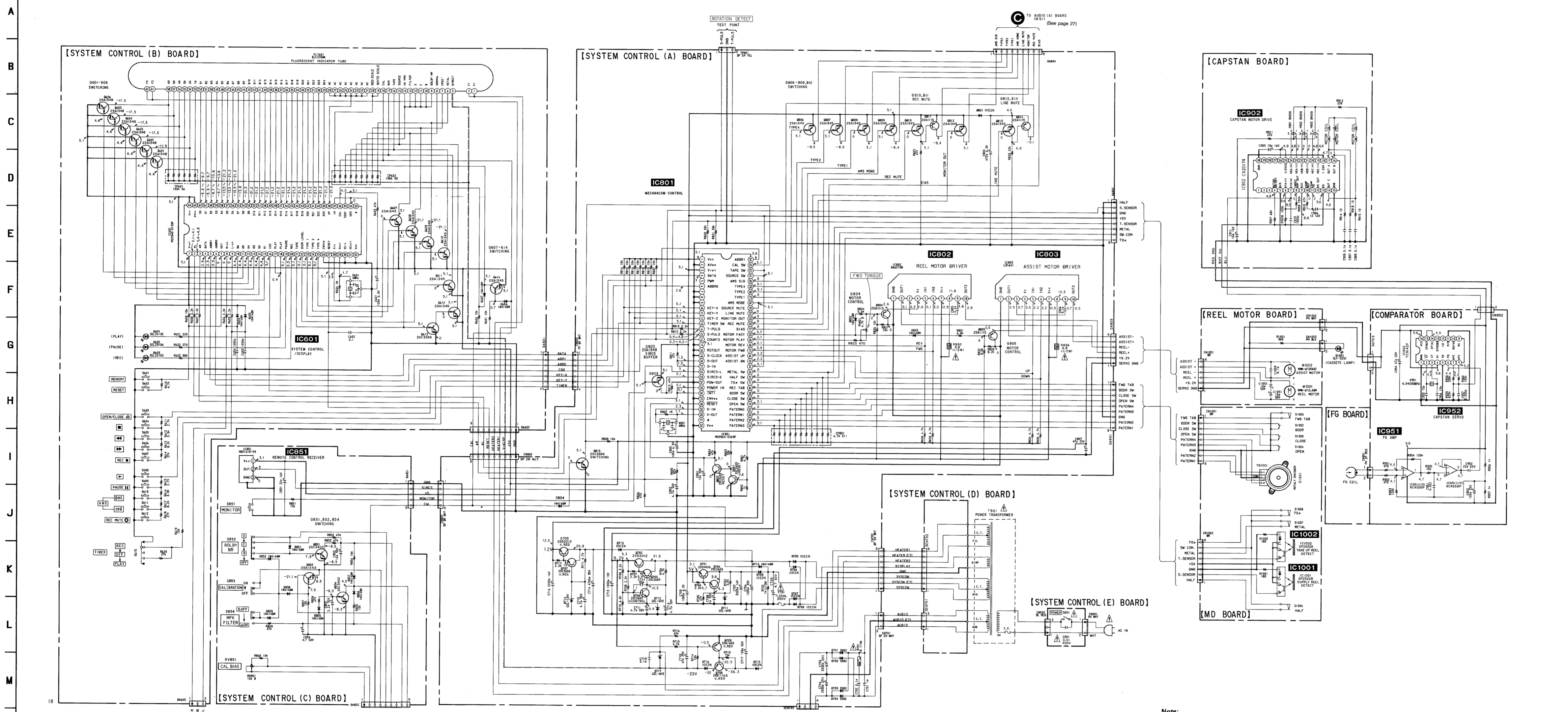

TO AUDIO (A) BOARD CN 510 (See page 27) TO AUDIO (A) BOARD CN 501 (See page 28) TO AUDIO (A) BOARD CN 511 (See page 27)

• IC Block Diagrams

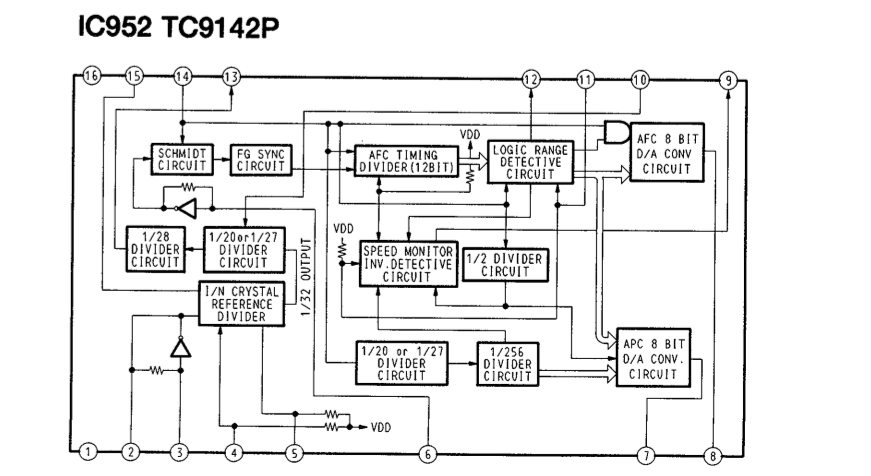
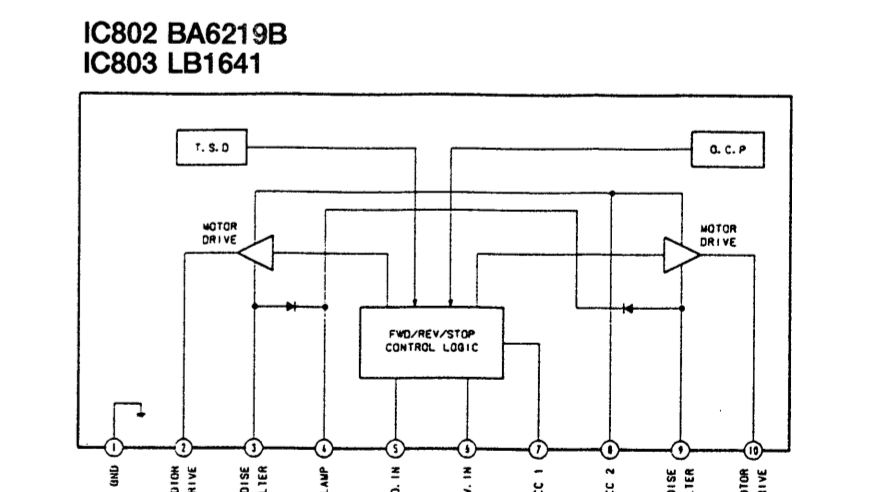
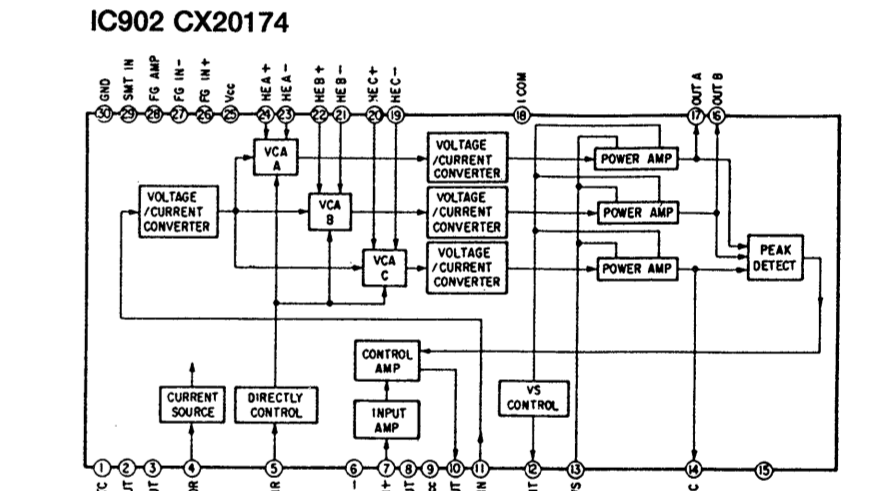

Note:
 • All capacitors are in μF unless otherwise noted. pF : μF 50WV or less are not indicated except for electrolytics and tantalums.
 • All resistors are in Ω and $1/4\text{W}$ or less unless otherwise specified.
 • % : indicates tolerance.
 • Δ : internal component.
 • \square : nonflammable resistor.
 • --- : fusible resistor.

Note:
 The components identified by mark **A** or dotted line with mark **A** are critical for safety. Replace only with part number specified.

• \square : B+ Line
 • \square : B- Line
 • \square : adjustment for repair.
 • Voltage is dc with respect to ground under no-signal conditions.
 • Voltages are taken with a VOM (Input Impedance 10M Ω). Voltage variations may be noted due to normal production tolerances.

5-7. PRINTED WIRING BOARDS—SYSTEM CONTROL Section— See page 16 for Circuit Boards Location and Semiconductor Lead Layouts.

• Semiconductor Location

Ref. No.	Location	Ref. No.	Location
D601	I-16	IC1001	H-10
D602	J-16	IC1002	H-9
D603	J-14		
D604	H-18	Q601	G-18
D605	H-18	Q602	G-18
D606	H-14	Q603	G-18
D607	G-16	Q604	H-18
D701	B-7	Q605	H-18
D702	B-7	Q606	H-18
D703	B-8	Q607	G-14
D704	B-7	Q608	G-14
D705	C-7	Q609	H-14
D706	C-7	Q610	G-14
D707	B-6	Q611	G-15
D708	B-6	Q612	H-15
D709	C-7	Q613	H-15
D710	E-5	Q614	H-14
D711	C-9	Q701	C-9
D712	D-8	Q702	D-8
D713	E-7	Q703	E-8
D714	E-8	Q704	B-9
D715	D-6	Q705	D-9
D716	D-6	Q706	D-8
D717	D-6	Q707	E-9
D801	D-3	Q708	D-6
D802	D-3	Q709	D-6
D803	D-3	Q801	B-5
D804	E-3	Q802	B-5
D851	A-11	Q803	B-4
D852	B-11	Q804	D-4
D853	B-11	Q805	D-4
D856	E-12	Q807	D-2
D857	E-12	Q808	D-2
D858	B-12	Q809	D-2
D1001	G-3	Q810	D-3
		Q811	D-3
IC601	G-17	Q812	D-3
IC801	C-3	Q813	D-3
IC802	D-4	Q814	D-2
IC803	D-4	Q815	C-1
IC851	D-11	Q851	D-11
IC902	J-6	Q852	B-12
IC951	J-3	Q854	D-12
IC952	J-2		

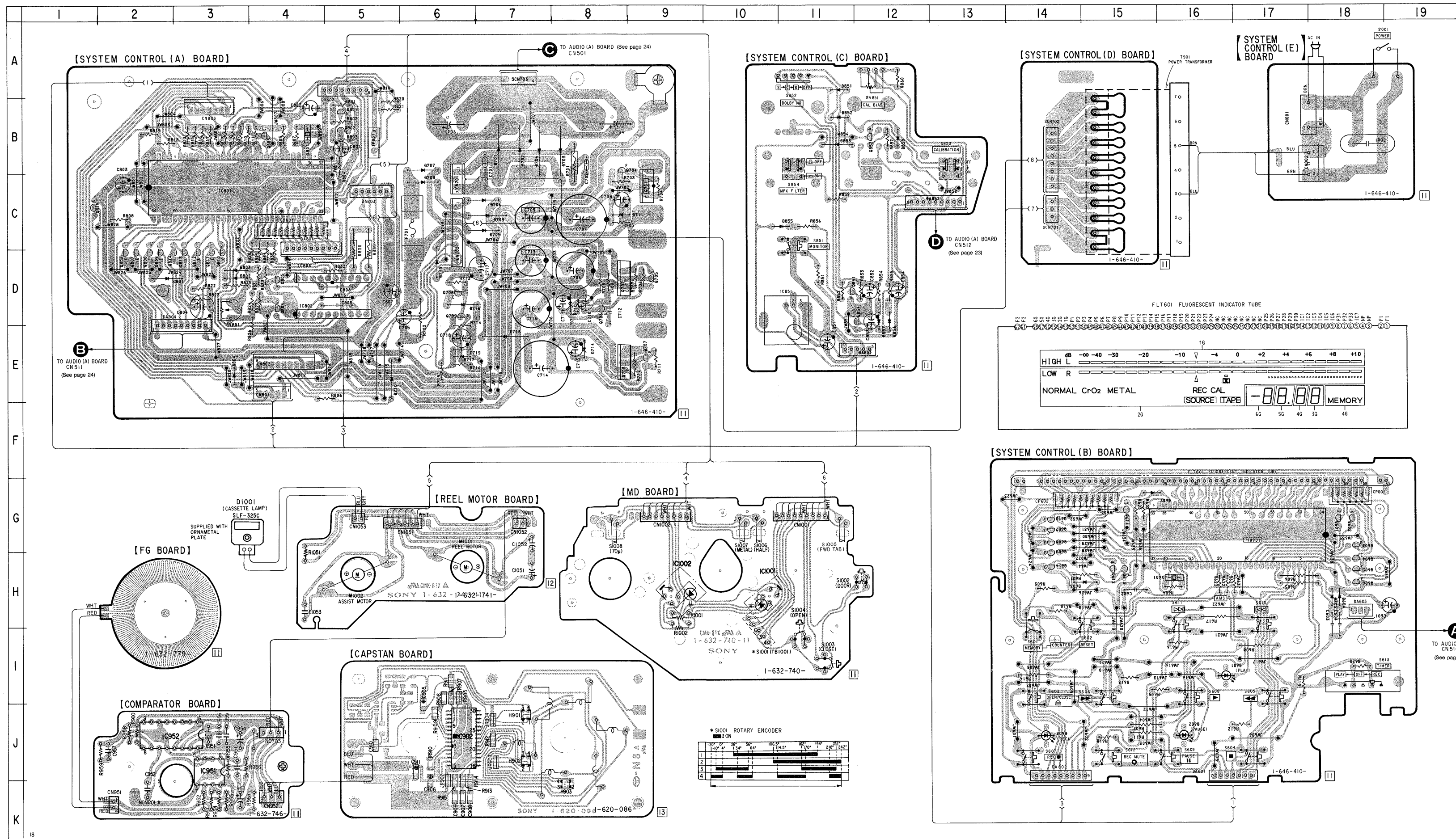

Note:
 ● ○ : parts extracted from the component side.
 ● ■ : parts mounted on the conductor side.
 ● □ : Pattern on the side which is seen.

• IC Block Diagram

IC1 CXA1417Q

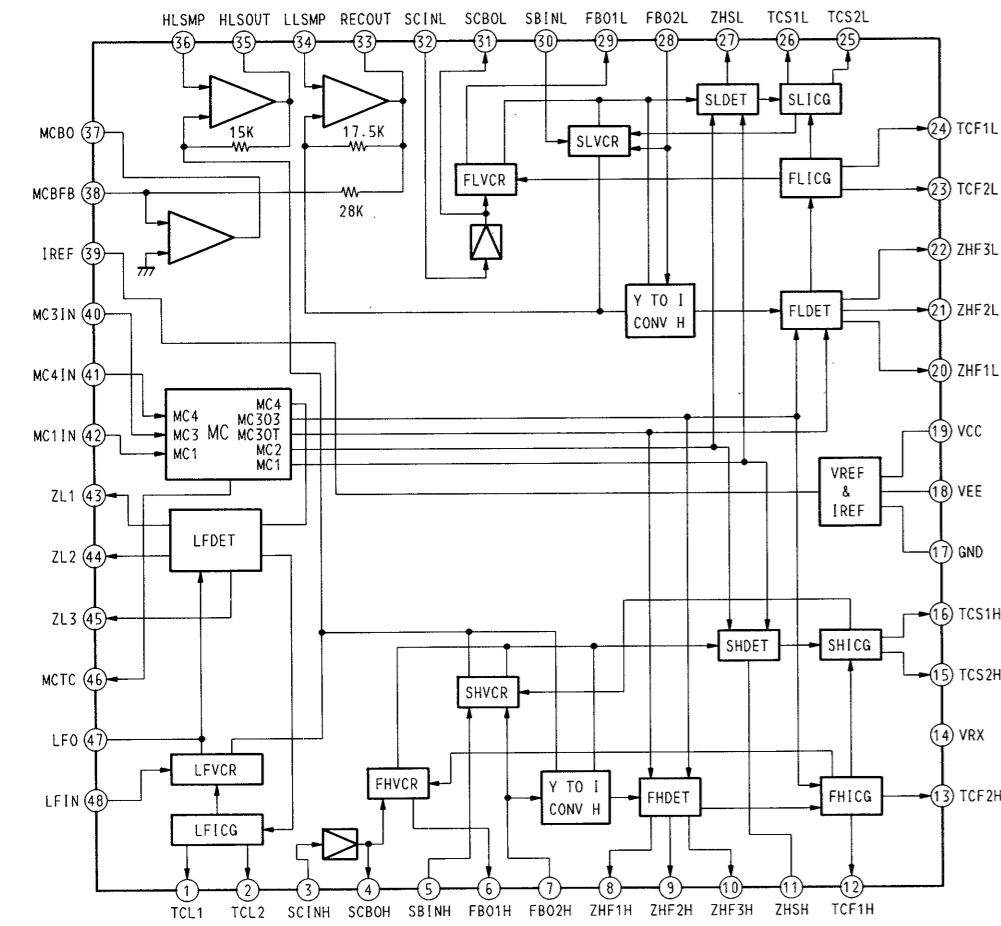

Note:

- All capacitors are in μF unless otherwise noted. $\text{pF} = \mu\text{F} \times 10^{-6}$. 50WV or less are not indicated except for electrolytics and tantalums.
- All resistors are in Ω and $1/4\text{W}$ or less unless otherwise specified.
- % : indicates tolerance.
- — : B+ Line
- - - - : B- Line
- Voltage is dc with respect to ground under no-signal conditions.
- Voltages are taken with a VOM (Input Impedance $10\text{M}\Omega$). Voltage variations may be noted due to normal production tolerances.
- Signal path.
 - ◁ : PB
 - ▷ : REC

5-8. SCHEMATIC DIAGRAM —DOLBY S Section—

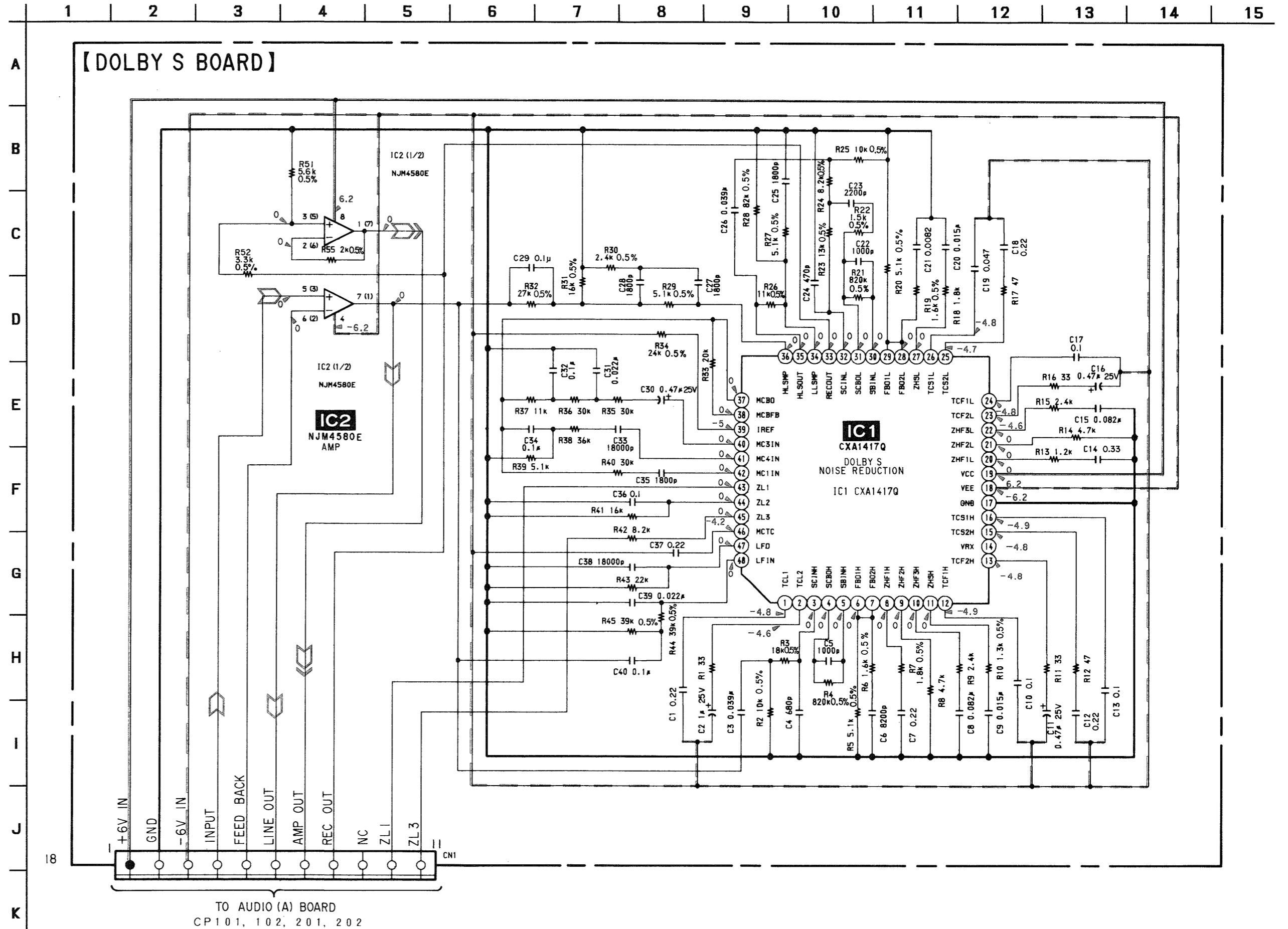

TO AUDIO (A) BOARD
 CP101, 102, 201, 202
 (See page 26)

6-2. CHASSIS SECTION

- C : SYSTEM CONTROL (C) board
- D : SYSTEM CONTROL (D) board
- B : AUDIO (B) board
- C : AUDIO (C) board
- D : AUDIO (D) board
- E : AUDIO (E) board

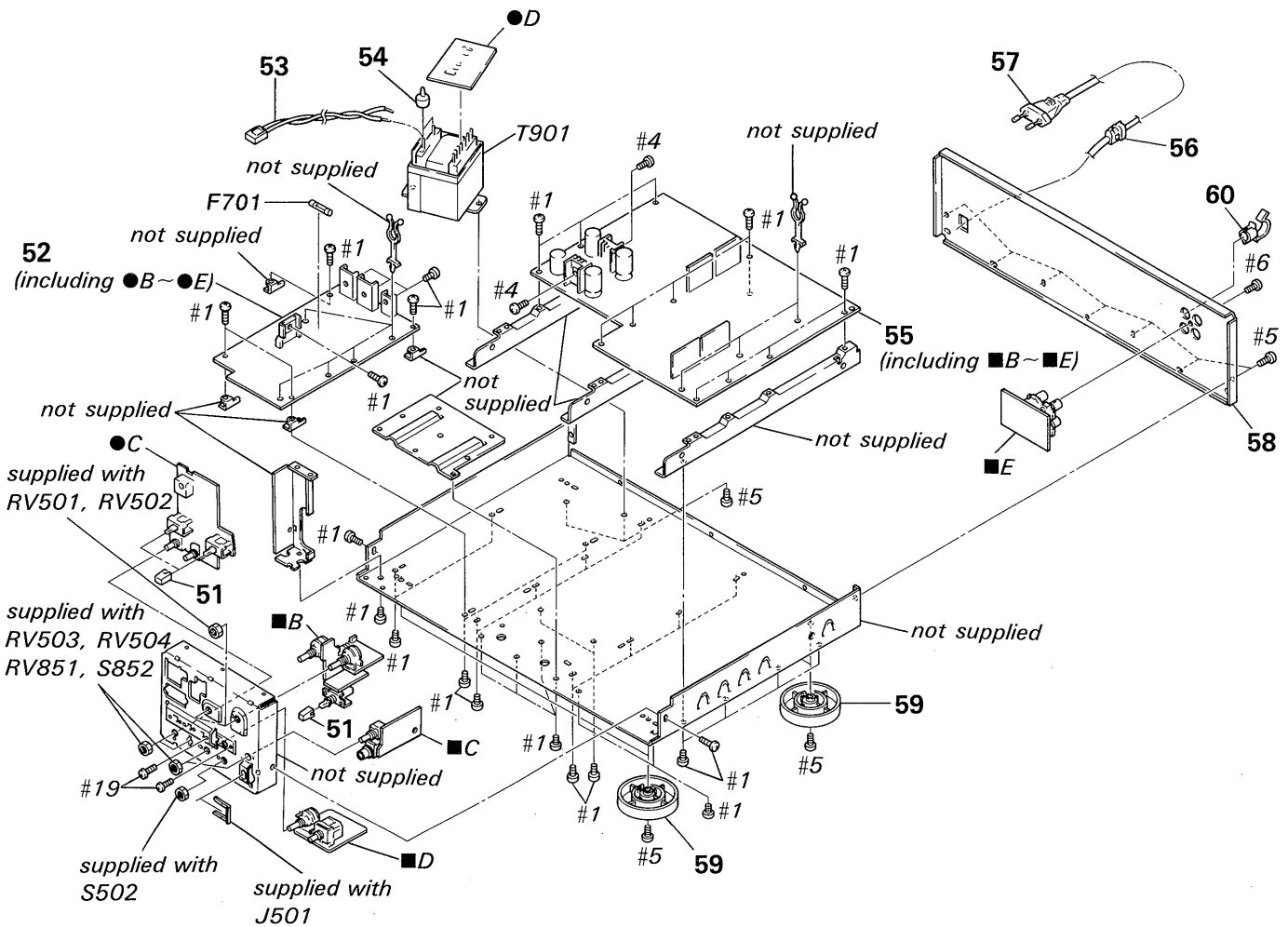

The components identified by mark \triangle or dotted line with mark \triangle are critical for safety. Replace only with part number specified.

Ref. No.	Part No.	Description	Remark
	51	3-380-952-01 BUTTON (BLK)	
	51	3-380-952-11 BUTTON (GLD)	
*	52	A-2007-027-A SYSTEM CONTROL BOARD, COMPLETE	
*	53	1-590-321-61 LEAD (WITH CONNECTOR)	
*	54	4-912-962-01 COVER (1P), TERMINAL	
*	55	A-2007-026-A AUDIO BOARD, COMPLETE	
*	56	3-703-244-00 BUSHING (2104), CORD	
\triangle 57	1-575-651-21	CORD, POWER	

Ref. No.	Part No.	Description	Remark
* 58	3-387-981-01	PANEL, BACK (BLK)	
* 58	3-387-981-11	PANEL, BACK (GLD)	
	59	X-3304-944-1 FOOT ASSY (BLK)	
	59	X-3363-489-1 FOOT ASSY (GLD)	
* 60	4-949-235-01	HOOK	
\triangle F701	1-532-285-00	FUSE, TIME-LAG (T1.25AL/250V)	
\triangle T901	1-423-685-11	TRANSFORMER, POWER	

6-3. MECHANISM SECTION-1
(TCM-200D14)

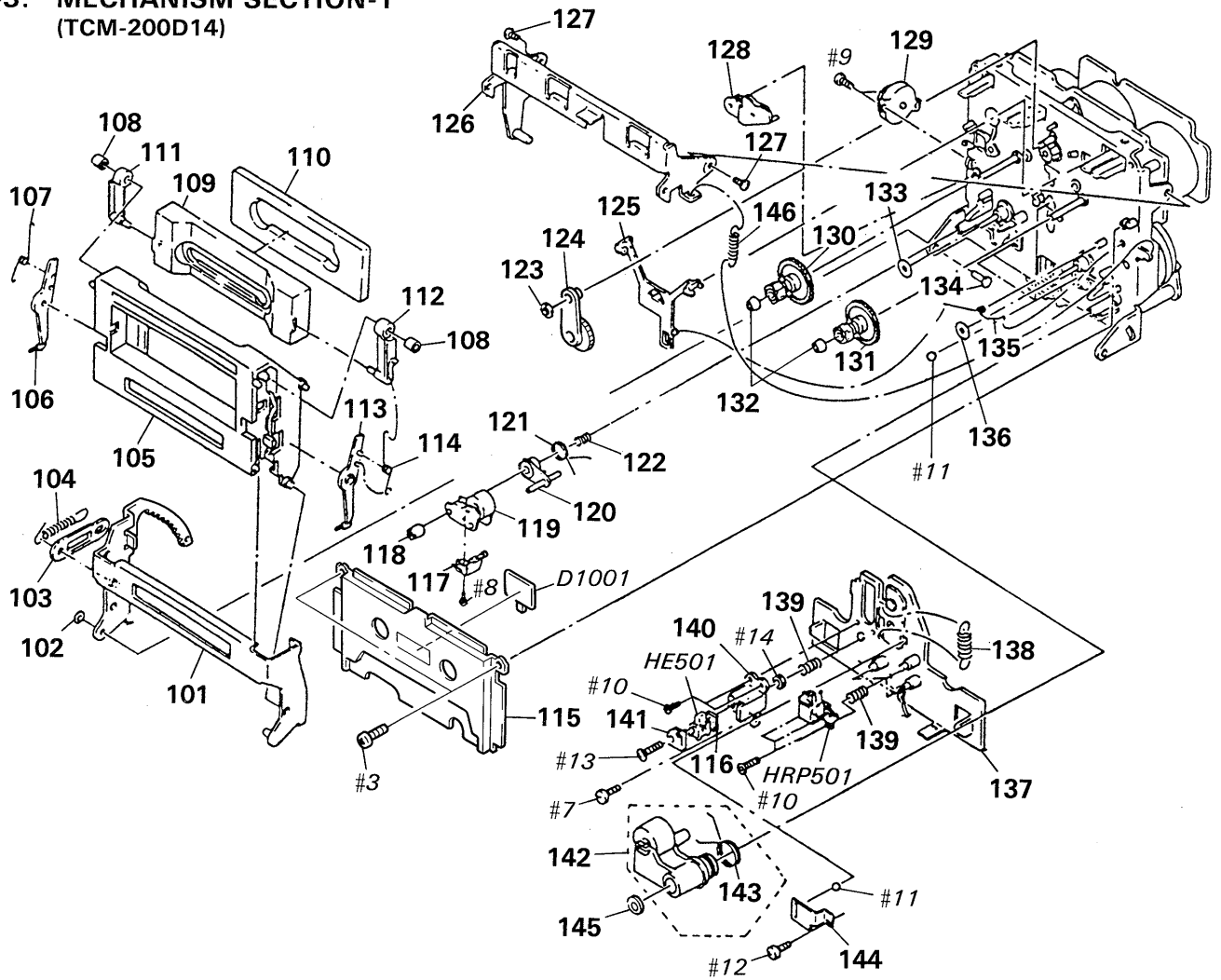

Ref. No.	Part No.	Description	Remark
	101	X-3362-671-1 HOLDER (BG) ASSY, CASSETTE	
	102	3-558-708-11 WASHER, STOPPER	
*	103	3-356-717-01 LEVER (JOINT)	
	104	3-356-626-01 SPRING, TENSION	
	105	X-3365-065-1 HOLDER (D9) ASSY, CASSETTE	
	106	3-356-932-01 LEVER (LA)	
	107	3-356-927-01 SPRING (LEFT), TORSION	
	108	3-356-946-01 BUSHING	
	109	3-356-928-11 PLATE (A), ORNAMENTAL	
*	110	3-356-929-01 ABSORBENT, VIBRATION	
	111	3-356-933-01 LEVER (LB)	
	112	3-356-931-01 LEVER (RB)	
	113	3-356-930-01 LEVER (RA)	
	114	3-356-926-01 SPRING (RIGHT), TORSION	
	115	X-3356-613-1 PLATE ASSY, ORNAMENTAL	
*	116	1-608-268-00 PC BOARD, ERASE HEAD	
	117	3-389-445-01 GUIDE (SL), TAPE	
	118	3-356-652-01 NUT (PINCH LEVER S)	
	119	X-3356-621-1 LEVER (PINCH LEVER S) ASSY	
	120	3-356-660-01 LEVER (PS)	
	121	3-356-661-01 SPRING (PINCH LEVER S), TORSION	
	122	3-356-657-01 SPRING (PS), COMPRESSION	
	123	3-669-465-11 WASHER (1.5), STOPPER	
	124	X-3356-641-1 LEVER (FR2) ASSY	
	125	3-356-614-01 SLIDER (BRAKE)	

Ref. No.	Part No.	Description	Remark
*	126	X-3356-608-1 LEVER (LIFTER) ASSY	
	127	3-356-601-11 SCREW, STEP	
	128	X-3356-623-1 LEVER (BT) ASSY	
	129	3-319-224-41 DAMPER, SMALL	
	130	X-3356-629-1 GEAR (S) ASSY	
	131	X-3356-627-1 GEAR (T) ASSY	
	132	3-362-308-01 CAP (REEL)	
	133	3-356-713-01 WASHER	
	134	3-356-710-01 SHAFT (LEFT) (CASSETTE HOLDER)	
	135	3-356-619-01 SPRING (B), TORSION	
	136	3-332-763-01 RING, OIL RESERVOIR	
*	137	X-3362-199-1 SLIDER (HEAD CHASSIS D) ASSY	
	138	3-356-658-01 SPRING (LIMITER H), TENSION	
	139	3-564-121-00 SPRING, COMPRESSION	
*	140	3-576-977-00 BRACKET, E. HEAD	
	141	3-318-433-01 SPRING	
	142	X-3356-620-1 LEVER (PINCH LEVER T) ASSY	
	143	3-356-672-01 SPRING (PINCH LEVER T), TORSION	
	144	3-356-656-01 SPRING (HEAD PC BOARD), LEAF	
	145	3-669-596-00 WASHER (2.3), STOPPER	
	146	3-376-854-01 SPRING, TENSION	
	D1001	8-719-980-85 DIODE SLF-325C	
	HE501	1-543-836-11 HEAD, MAGNETIC (ERASE)	
	HRP501	1-543-742-11 HEAD, MAGNETIC (REC/PB)	

6-4. MECHANISM SECTION-2
(TCM-200D14)

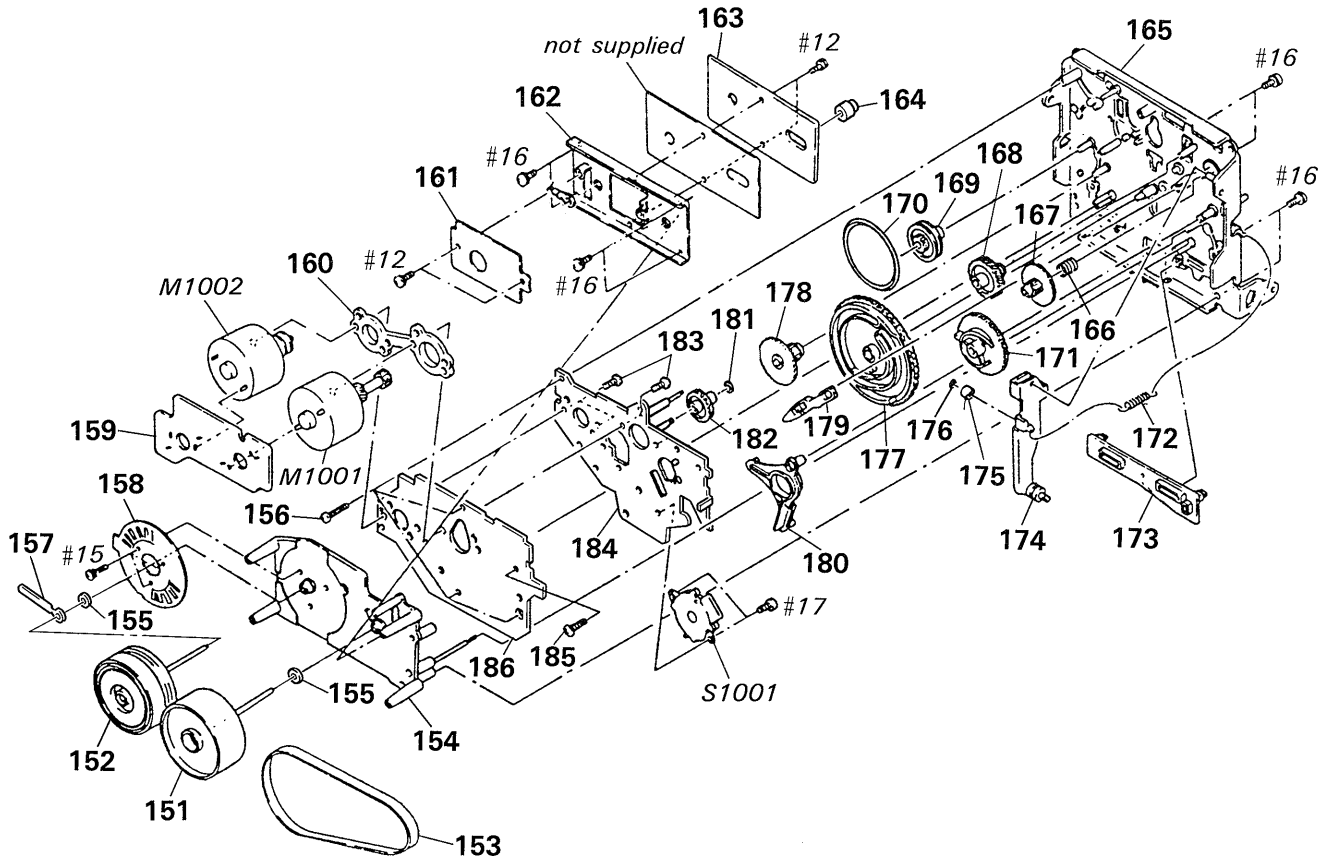

Ref. No.	Part No.	Description	Remark
151	X-3362-284-1	FLYWHEEL (S2.3) ASSY	
152	X-3356-619-1	FLYWHEEL (DT) ASSY	
153	3-364-600-01	BELT (CAPSTAN)	
154	X-3362-281-1	CHASSIS (D2.3) ASSY	
155	3-356-705-31	WASHER (CAPSTAN)	
156	3-381-811-01	SCREW (PTPWH) (2X18)	
157	3-703-150-11	STOPPER, WIRING	
158	1-632-779-11	PC BOARD, FG	
* 159	1-632-741-11	REEL MOTOR BOARD	
* 160	3-356-628-01	SPACER (MOTOR)	
* 161	1-632-746-11	COMPARATOR BOARD	
* 162	X-3362-282-1	BRACKET (THRUST RETAINER) ASSY	
163	A-2006-154-A	CAPSTAN C. O. C BOARD, COMPLETE	
164	3-364-135-01	RETAINER (S), THRUST	
165	X-3356-622-1	CHASSIS (C) ASSY, MECHANICAL	
166	3-356-605-01	SPRING, COMPRESSION	
167	3-356-609-01	GEAR (LOADING)	
168	3-356-703-01	GEAR (COMMUNICATION C)	
169	3-356-607-01	PULLEY (MODE)	
170	3-356-603-01	BELT (MODE)	

Ref. No.	Part No.	Description	Remark
171	3-356-616-01	GEAR (LOADING CAM)	
172	3-356-625-01	SPRING, TENSION	
173	3-356-653-01	SLIDER (PAUSE)	
* 174	X-3356-606-1	LEVER (LOADING) ASSY	
175	3-356-630-01	ROLLER (LOADING)	
176	3-558-708-21	WASHER, STOPPER	
177	3-356-654-01	GEAR (MODE CAM C)	
178	3-356-606-01	GEAR (MODE)	
179	3-356-617-01	LEVER (SELECTION)	
180	3-356-613-01	LEVER (MODE)	
181	3-669-465-00	WASHER (1.5), STOPPER	
182	3-356-702-01	GEAR (COMMUNICATION B)	
183	3-363-804-01	SCREW (+P 2.6X6.5)	
* 184	X-3356-616-1	BRACKET (MOTOR D) ASSY	
185	3-356-707-01	SCREW (+PTPWH 2X25)	
* 186	1-632-740-11	MD BOARD	
M1001	X-3356-638-1	MOTOR (REEL R) ASSY	
M1002	X-3356-604-1	MOTOR (ASSIST) ASSY	
S1001	1-466-238-11	ENCODER, ROTARY	

SECTION 7 ELECTRICAL PARTS LIST

AUDIO

DOLBY S

NOTE:

- Due to standardization, replacements in the parts list may be different from the parts specified in the diagrams or the components used on the set.
- -XX and -X mean standardized parts, so they may have some difference from the original one.
- RESISTORS
All resistors are in ohms.
METAL: Metal-film resistor.
METAL OXIDE: Metal oxide-film resistor.
F: nonflammable

- Items marked "*" are not stocked since they are seldom required for routine service. Some delay should be anticipated when ordering these items.
- SEMICONDUCTORS
In each case, u: μ , for example:
uA ..: μ A. uPA..: μ PA.
uPB..: μ PB. uPC..: μ PC. uPD..: μ PD.
- CAPACITORS
uF: μ F
- COILS
uH: μ H

The components identified by mark Δ or dotted line with mark Δ are critical for safety. Replace only with part number specified.

When indicating parts by reference number, please include the board.

Ref. No.	Part No.	Description	Remark
*	A-2007-026-A	AUDIO BOARD, COMPLETE *****	
		DOLBY S BOARD *****	
	7-682-147-15	SCREW, TR	
*	4-886-555-00	HEAT SINK	
*	4-942-204-01	PLATE, GROUND	
		< CAPACITOR >	
C1	1-164-222-11	CERAMIC CHIP 0.22uF	25V
C2	1-135-177-21	TANTALUM CHIP 1uF	20% 20V
C3	1-137-301-11	FILM CHIP 0.039uF	5% 16V
C4	1-163-007-11	CERAMIC CHIP 680PF	10% 50V
C5	1-163-009-11	CERAMIC CHIP 0.001uF	10% 50V
C6	1-164-717-11	CERAMIC CHIP 0.0082uF	5% 50V
C7	1-164-222-11	CERAMIC CHIP 0.22uF	25V
C8	1-104-562-11	FILM CHIP 0.082uF	5% 16V
C9	1-104-553-11	FILM CHIP 0.015uF	5% 16V
C10	1-165-319-11	CERAMIC CHIP 0.1uF	50V
C11	1-135-145-11	TANTALUM CHIP 0.47uF	10% 35V
C12	1-164-222-11	CERAMIC CHIP 0.22uF	25V
C13	1-165-319-11	CERAMIC CHIP 0.1uF	50V
C14	1-162-568-11	CERAMIC CHIP 0.33uF	10% 16V
C15	1-104-562-11	FILM CHIP 0.082uF	5% 16V
C16	1-135-145-11	TANTALUM CHIP 0.47uF	10% 35V
C17	1-165-319-11	CERAMIC CHIP 0.1uF	50V
C18	1-164-222-11	CERAMIC CHIP 0.22uF	25V
C19	1-163-035-00	CERAMIC CHIP 0.047uF	50V
C20	1-104-553-11	FILM CHIP 0.015uF	5% 16V
C21	1-164-717-11	CERAMIC CHIP 0.0082uF	5% 50V
C22	1-163-009-11	CERAMIC CHIP 0.001uF	10% 50V
C23	1-164-161-11	CERAMIC CHIP 0.0022uF	10% 100V
C24	1-163-005-11	CERAMIC CHIP 470PF	10% 50V
C25	1-163-012-00	CERAMIC CHIP 0.0018uF	10% 50V
C26	1-137-301-11	FILM CHIP 0.039uF	5% 16V
C27	1-163-012-00	CERAMIC CHIP 0.0018uF	10% 50V
C28	1-163-012-00	CERAMIC CHIP 0.0018uF	10% 50V
C29	1-137-306-11	FILM CHIP 0.1uF	5% 16V
C30	1-135-145-11	TANTALUM CHIP 0.47uF	10% 35V

Ref. No.	Part No.	Description	Remark
C31	1-104-555-11	FILM CHIP 0.022uF	5% 16V
C32	1-104-563-11	FILM CHIP 0.1uF	5% 16V
C33	1-163-024-00	CERAMIC CHIP 0.018uF	10% 50V
C34	1-137-306-11	FILM CHIP 0.1uF	5% 16V
C35	1-163-012-00	CERAMIC CHIP 0.0018uF	10% 50V
C36	1-165-319-11	CERAMIC CHIP 0.1uF	50V
C37	1-164-222-11	CERAMIC CHIP 0.22uF	25V
C38	1-163-024-00	CERAMIC CHIP 0.018uF	10% 50V
C39	1-104-555-11	FILM CHIP 0.022uF	5% 16V
C40	1-137-306-11	FILM CHIP 0.1uF	5% 16V
C101	1-130-487-00	MYLAR 0.022uF	5% 50V
C102	1-126-049-11	ELECT 22uF	20% 50V
C103	1-126-049-11	ELECT 22uF	20% 50V
C104	1-130-489-00	MYLAR 0.033uF	5% 50V
C105	1-130-477-00	MYLAR 0.0033uF	5% 50V
C106	1-102-965-00	CERAMIC 39PF	5% 50V
C107	1-106-343-00	MYLAR 1000PF	5% 200V
C108	1-130-475-00	MYLAR 0.0022uF	5% 50V
C109	1-130-475-00	MYLAR 0.0022uF	5% 50V
C110	1-130-478-00	MYLAR 0.0039uF	5% 50V
C111	1-136-173-00	FILM 0.47uF	5% 50V
C112	1-136-167-00	FILM 0.15uF	5% 50V
C113	1-136-155-00	FILM 0.015uF	5% 50V
C114	1-124-903-11	ELECT 1uF	20% 50V
C115	1-136-169-00	FILM 0.22uF	5% 50V
C116	1-136-163-00	FILM 0.068uF	5% 50V
C117	1-136-162-00	FILM 0.056uF	5% 50V
C118	1-124-903-11	ELECT 1uF	20% 50V
C119	1-130-480-00	MYLAR 0.0056uF	5% 50V
C120	1-136-153-00	FILM 0.01uF	5% 50V
C121	1-126-049-11	ELECT 22uF	20% 50V
C122	1-126-049-11	ELECT 22uF	20% 50V
C123	1-126-049-11	ELECT 22uF	20% 50V
C124	1-126-059-11	ELECT 10uF	20% 50V
C125	1-126-049-11	ELECT 22uF	20% 50V
C126	1-126-049-11	ELECT 22uF	20% 50V
C127	1-123-382-00	ELECT 3.3uF	20% 100V
C129	1-124-925-11	ELECT 2.2uF	20% 100V
C130	1-130-475-00	MYLAR 0.0022uF	5% 50V
C132	1-126-059-11	ELECT 10uF	20% 50V

AUDIO

DOLBY S

Ref. No.	Part No.	Description		Remark
C133	1-126-163-11	ELECT	4. 7uF	20% 50V
C134	1-126-163-11	ELECT	4. 7uF	20% 50V
C135	1-126-163-11	ELECT	4. 7uF	20% 50V
C136	1-102-518-11	CERAMIC	33PF	5% 50V
C137	1-130-475-00	MYLAR	0. 0022uF	5% 50V
C138	1-130-475-00	MYLAR	0. 0022uF	5% 50V
C139	1-130-478-00	MYLAR	0. 0039uF	5% 50V
C140	1-136-173-00	FILM	0. 47uF	5% 50V
C141	1-136-167-00	FILM	0. 15uF	5% 50V
C142	1-136-155-00	FILM	0. 015uF	5% 50V
C143	1-124-903-11	ELECT	1uF	20% 50V
C144	1-136-169-00	FILM	0. 22uF	5% 50V
C145	1-136-163-00	FILM	0. 068uF	5% 50V
C146	1-136-162-00	FILM	0. 056uF	5% 50V
C147	1-124-903-11	ELECT	1uF	20% 50V
C148	1-130-480-00	MYLAR	0. 0056uF	5% 50V
C149	1-136-153-00	FILM	0. 01uF	5% 50V
C150	1-126-059-11	ELECT	10uF	20% 50V
C151	1-126-059-11	ELECT	10uF	20% 50V
C152	1-126-049-11	ELECT	22uF	20% 50V
C153	1-126-059-11	ELECT	10uF	20% 50V
C154	1-126-049-11	ELECT	22uF	20% 50V
C155	1-126-049-11	ELECT	22uF	20% 50V
C156	1-106-347-00	MYLAR	1500PF	5% 200V
C157	1-106-343-00	MYLAR	1000PF	5% 200V
C158	1-130-474-00	MYLAR	0. 0018uF	5% 50V
C159	1-126-059-11	ELECT	10uF	20% 50V
C160	1-130-491-00	MYLAR	0. 047uF	5% 50V
C161	1-130-485-00	MYLAR	0. 015uF	5% 50V
C162	1-130-487-00	MYLAR	0. 022uF	5% 50V
C163	1-130-486-00	MYLAR	0. 018uF	10% 50V
C164	1-130-487-00	MYLAR	0. 022uF	5% 50V
C165	1-130-486-00	MYLAR	0. 018uF	10% 50V
C166	1-126-049-11	ELECT	22uF	20% 50V
C167	1-106-347-00	MYLAR	1500PF	5% 200V
C168	1-136-935-11	FILM	22PF	5% 630V
C169	1-136-157-00	FILM	0. 022uF	5% 50V
C170	1-136-161-00	FILM	0. 047uF	5% 50V
C171	1-130-468-00	MYLAR	560PF	5% 50V
C172	1-136-803-11	FILM	560PF	5% 630V
C173	1-136-433-11	FILM	100PF	5% 630V
C174	1-136-153-00	FILM	0. 01uF	5% 50V
C175	1-162-211-31	CERAMIC	33PF	5% 50V
C176	1-124-925-11	ELECT	2. 2uF	20% 100V
C178	1-126-059-11	ELECT	10uF	20% 50V
C179	1-110-340-11	MYLAR	270PF	5% 50V
C201	1-130-487-00	MYLAR	0. 022uF	5% 50V
C202	1-126-049-11	ELECT	22uF	20% 50V
C203	1-126-049-11	ELECT	22uF	20% 50V

Ref. No.	Part No.	Description		Remark
C204	1-130-489-00	MYLAR	0. 033uF	5% 50V
C205	1-130-477-00	MYLAR	0. 0033uF	5% 50V
C206	1-102-965-00	CERAMIC	39PF	5% 50V
C207	1-106-343-00	MYLAR	1000PF	5% 200V
C208	1-130-475-00	MYLAR	0. 0022uF	5% 50V
C209	1-130-475-00	MYLAR	0. 0022uF	5% 50V
C210	1-130-478-00	MYLAR	0. 0039uF	5% 50V
C211	1-136-173-00	FILM	0. 47uF	5% 50V
C212	1-136-167-00	FILM	0. 15uF	5% 50V
C213	1-136-155-00	FILM	0. 015uF	5% 50V
C214	1-124-903-11	ELECT	1uF	20% 50V
C215	1-136-169-00	FILM	0. 22uF	5% 50V
C216	1-136-163-00	FILM	0. 068uF	5% 50V
C217	1-136-162-00	FILM	0. 056uF	5% 50V
C218	1-124-903-11	ELECT	1uF	20% 50V
C219	1-130-480-00	MYLAR	0. 0056uF	5% 50V
C220	1-136-153-00	FILM	0. 01uF	5% 50V
C221	1-126-049-11	ELECT	22uF	20% 50V
C222	1-126-049-11	ELECT	22uF	20% 50V
C223	1-126-049-11	ELECT	22uF	20% 50V
C224	1-126-059-11	ELECT	10uF	20% 50V
C225	1-126-049-11	ELECT	22uF	20% 50V
C226	1-126-049-11	ELECT	22uF	20% 50V
C227	1-123-382-00	ELECT	3. 3uF	20% 100V
C229	1-136-165-00	FILM	0. 1uF	5% 50V
C232	1-126-059-11	ELECT	10uF	20% 50V
C233	1-126-163-11	ELECT	4. 7uF	20% 50V
C234	1-126-163-11	ELECT	4. 7uF	20% 50V
C235	1-126-163-11	ELECT	4. 7uF	20% 50V
C236	1-102-518-11	CERAMIC	33PF	5% 50V
C237	1-130-475-00	MYLAR	0. 0022uF	5% 50V
C238	1-130-475-00	MYLAR	0. 0022uF	5% 50V
C239	1-130-478-00	MYLAR	0. 0039uF	5% 50V
C240	1-136-173-00	FILM	0. 47uF	5% 50V
C241	1-136-167-00	FILM	0. 15uF	5% 50V
C242	1-136-155-00	FILM	0. 015uF	5% 50V
C243	1-124-903-11	ELECT	1uF	20% 50V
C244	1-136-169-00	FILM	0. 22uF	5% 50V
C245	1-136-163-00	FILM	0. 068uF	5% 50V
C246	1-136-162-00	FILM	0. 056uF	5% 50V
C247	1-124-903-11	ELECT	1uF	20% 50V
C248	1-130-480-00	MYLAR	0. 0056uF	5% 50V
C249	1-136-153-00	FILM	0. 01uF	5% 50V
C250	1-126-059-11	ELECT	10uF	20% 50V
C251	1-126-059-11	ELECT	10uF	20% 50V
C252	1-126-049-11	ELECT	22uF	20% 50V
C253	1-126-059-11	ELECT	10uF	20% 50V
C254	1-126-049-11	ELECT	22uF	20% 50V
C255	1-126-049-11	ELECT	22uF	20% 50V

AUDIO **DOLBY S**

Ref. No.	Part No.	Description	Remark
C256	1-106-347-00	MYLAR	1500PF 5% 200V
C257	1-106-343-00	MYLAR	1000PF 5% 200V
C258	1-130-474-00	MYLAR	0.0018uF 5% 50V
C259	1-126-059-11	ELECT	10uF 20% 50V
C260	1-130-491-00	MYLAR	0.047uF 5% 50V
C261	1-130-485-00	MYLAR	0.015uF 5% 50V
C262	1-130-487-00	MYLAR	0.022uF 5% 50V
C263	1-130-486-00	MYLAR	0.018uF 10% 50V
C264	1-130-487-00	MYLAR	0.022uF 5% 50V
C265	1-130-486-00	MYLAR	0.018uF 10% 50V
C266	1-126-049-11	ELECT	22uF 20% 50V
C267	1-106-347-00	MYLAR	1500PF 5% 200V
C268	1-136-935-11	FILM	22PF 5% 630V
C269	1-136-157-00	FILM	0.022uF 5% 50V
C270	1-136-161-00	FILM	0.047uF 5% 50V
C271	1-130-468-00	MYLAR	560PF 5% 50V
C272	1-136-803-11	FILM	560PF 5% 630V
C273	1-136-433-11	FILM	100PF 5% 630V
C274	1-136-153-00	FILM	0.01uF 5% 50V
C275	1-162-211-31	CERAMIC	33PF 5% 50V
C276	1-124-925-11	ELECT	2.2uF 20% 100V
C278	1-126-059-11	ELECT	10uF 20% 50V
C279	1-110-340-11	MYLAR	270PF 5% 50V
C501	1-126-066-11	ELECT	470uF 20% 63V
C502	1-126-066-11	ELECT	470uF 20% 63V
C503	1-102-518-11	CERAMIC	33PF 5% 50V
C504	1-102-518-11	CERAMIC	33PF 5% 50V
C505	1-124-122-11	ELECT	100uF 20% 50V
C506	1-136-153-00	FILM	0.01uF 5% 50V
C507	1-136-153-00	FILM	0.01uF 5% 50V
C508	1-124-922-11	ELECT	1000uF 20% 63V
C509	1-124-922-11	ELECT	1000uF 20% 63V
C510	1-126-059-11	ELECT	10uF 20% 50V
C511	1-126-059-11	ELECT	10uF 20% 50V
C513	1-126-163-11	ELECT	4.7uF 20% 50V
C514	1-126-163-11	ELECT	4.7uF 20% 50V
C515	1-164-159-11	CERAMIC	0.1uF 50V
C516	1-124-902-00	ELECT	0.47uF 20% 50V
C517	1-124-477-11	ELECT	47uF 20% 25V
C518	1-130-474-00	MYLAR	0.0018uF 5% 50V
C519	1-130-474-00	MYLAR	0.0018uF 5% 50V
C520	1-136-157-00	FILM	0.022uF 5% 50V
C521	1-136-157-00	FILM	0.022uF 5% 50V
C522	1-126-163-11	ELECT	4.7uF 20% 50V
C523	1-126-163-11	ELECT	4.7uF 20% 50V
C526	1-126-059-11	ELECT	10uF 20% 50V
C527	1-126-059-11	ELECT	10uF 20% 50V
C528	1-126-059-11	ELECT	10uF 20% 50V
C529	1-126-059-11	ELECT	10uF 20% 50V

Ref. No.	Part No.	Description	Remark
C530	1-126-163-11	ELECT	4.7uF 20% 50V
C531	1-126-163-11	ELECT	4.7uF 20% 50V
C532	1-124-925-11	ELECT	2.2uF 20% 100V
C533	1-126-059-11	ELECT	10uF 20% 50V
C534	1-124-477-11	ELECT	47uF 20% 25V
C536	1-124-907-11	ELECT	10uF 20% 50V
C537	1-124-925-11	ELECT	2.2uF 20% 100V
C538	1-162-282-31	CERAMIC	100PF 10% 50V
C539	1-136-228-11	FILM	0.0012uF 5% 100V
C540	1-136-228-11	FILM	0.0012uF 5% 100V
C541	1-136-233-11	FILM	0.0047uF 5% 100V
C542	1-124-907-11	ELECT	10uF 20% 50V
C543	1-136-559-11	FILM	0.0047uF 5% 630V
C544	1-107-045-00	MICA	3.9PF 500V

< CONNECTOR >

- * CN1 1-537-473-11 TERMINAL (LEAD PIN)
- * CN501 1-564-506-11 PLUG, CONNECTOR 3P
- * CN502 1-560-062-00 PIN, CONNECTOR 4P
- * CN503 1-564-508-11 PLUG, CONNECTOR 5P
- * CN504 1-564-519-11 PLUG, CONNECTOR 4P
- * CN505 1-564-523-11 PLUG, CONNECTOR 8P
- * CN506 1-564-507-31 PLUG, CONNECTOR 4P
- * CN507 1-564-509-11 PLUG, CONNECTOR 6P
- * CN508 1-560-062-00 PIN, CONNECTOR 4P
- * CN509 1-560-061-00 PIN, CONNECTOR 3P
- * CN510 1-564-337-51 PIN, CONNECTOR 3P
- * CN511 1-506-503-61 PIN, CONNECTOR 9P
- * CN512 1-506-503-11 PIN, CONNECTOR 9P

< COMPOSITION CIRCUIT BLOCK >

- CP103 1-236-087-11 FILTER, LOW PASS
- CP203 1-236-087-11 FILTER, LOW PASS

< DIODE >

- D101 8-719-987-63 DIODE 1N4148M
- D102 8-719-987-63 DIODE 1N4148M
- D103 8-719-987-63 DIODE 1N4148M
- D104 8-719-987-63 DIODE 1N4148M
- D105 8-719-987-63 DIODE 1N4148M
- D106 8-719-987-63 DIODE 1N4148M
- D107 8-719-000-54 DIODE UZL-6L3
- D108 8-719-987-63 DIODE 1N4148M
- D109 8-719-987-63 DIODE 1N4148M
- D201 8-719-987-63 DIODE 1N4148M
- D202 8-719-987-63 DIODE 1N4148M
- D203 8-719-987-63 DIODE 1N4148M
- D204 8-719-987-63 DIODE 1N4148M
- D205 8-719-987-63 DIODE 1N4148M

AUDIO

DOLBY S

Ref. No.	Part No.	Description	Remark
D206	8-719-987-63	DIODE 1N4148M	
D207	8-719-000-54	DIODE UZL-6L3	
D208	8-719-987-63	DIODE 1N4148M	
D209	8-719-987-63	DIODE 1N4148M	
D501	8-719-933-41	DIODE HZS6C3L	
D503	8-719-987-63	DIODE 1N4148M	
D504	8-719-987-63	DIODE 1N4148M	
D505	8-719-987-63	DIODE 1N4148M	
D506	8-719-987-63	DIODE 1N4148M	
D507	8-719-987-63	DIODE 1N4148M	
D508	8-719-987-63	DIODE 1N4148M	
D509	8-719-987-63	DIODE 1N4148M	
D510	8-719-987-63	DIODE 1N4148M	
D511	8-719-987-63	DIODE 1N4148M	
D512	8-719-987-63	DIODE 1N4148M	
D513	8-719-987-63	DIODE 1N4148M	
D514	8-719-987-63	DIODE 1N4148M	
D515	8-719-987-63	DIODE 1N4148M	
D516	8-719-987-63	DIODE 1N4148M	
D517	8-719-987-63	DIODE 1N4148M	
D518	8-719-987-63	DIODE 1N4148M	
D519	8-719-987-63	DIODE 1N4148M	
D520	8-719-987-63	DIODE 1N4148M	
D521	8-719-987-63	DIODE 1N4148M	
D522	8-719-987-63	DIODE 1N4148M	
D523	8-719-987-63	DIODE 1N4148M	
D524	8-719-987-63	DIODE 1N4148M	
D525	8-719-987-63	DIODE 1N4148M	
D526	8-719-987-63	DIODE 1N4148M	
< IC >			
IC1	8-752-056-51	IC CXA1417Q	
IC2	8-759-711-85	IC NJM4580E-D	
IC501	8-759-602-01	IC M5220P	
IC502	8-752-018-80	IC CX20188	
IC503	8-759-710-59	IC NJM4580D-D	
IC506	8-759-145-58	IC uPC4558C	
IC507	8-759-634-50	IC M5218AL	
IC508	8-759-145-58	IC uPC4558C	
IC509	8-759-145-58	IC uPC4558C	
IC510	8-759-145-58	IC uPC4558C	
IC511	8-752-018-80	IC CX20188	
IC513	8-759-710-59	IC NJM4580D-D	
IC514	8-759-106-56	IC uPC1297CA	
IC516	8-759-145-58	IC uPC4558C	
IC517	8-759-634-51	IC M5218AP	

Ref. No.	Part No.	Description	Remark
< JACK >			
J501	1-507-796-71	JACK (HEADPHONES)	
* J502	1-573-142-41	JACK, PIN 4P (LINE IN/OUT)	
< COIL >			
L101	1-408-927-11	INDUCTOR 18mH	
L102	1-408-920-00	INDUCTOR 4.7mH	
L103	1-408-918-11	INDUCTOR 3.3mH	
L104	1-408-916-11	INDUCTOR 2.2mH	
L105	1-408-929-00	INDUCTOR 27mH	
L201	1-408-927-11	INDUCTOR 18mH	
L202	1-408-920-00	INDUCTOR 4.7mH	
L203	1-408-918-11	INDUCTOR 3.3mH	
L204	1-408-916-11	INDUCTOR 2.2mH	
L205	1-408-929-00	INDUCTOR 27mH	
< PILOT LAMP >			
PL501	1-518-471-31	LAMP, PILOT	
PL502	1-518-471-31	LAMP, PILOT	
< IC LINK >			
△PS501	1-532-605-00	LINK, IC ICP-N10 (0.4A)	
△PS502	1-532-605-00	LINK, IC ICP-N10 (0.4A)	
△PS503	1-532-605-00	LINK, IC ICP-N10 (0.4A)	
△PS504	1-532-605-00	LINK, IC ICP-N10 (0.4A)	
< TRANSISTOR >			
Q101	8-729-922-37	TRANSISTOR 2SD2144S-UVW	
Q102	8-729-922-37	TRANSISTOR 2SD2144S-UVW	
Q103	8-729-203-06	TRANSISTOR 2SK30A-GR2	
Q104	8-729-203-06	TRANSISTOR 2SK30A-GR2	
Q105	8-729-203-06	TRANSISTOR 2SK30A-GR2	
Q106	8-729-203-06	TRANSISTOR 2SK30A-GR2	
Q107	8-729-922-37	TRANSISTOR 2SD2144S-UVW	
Q108	8-729-922-37	TRANSISTOR 2SD2144S-UVW	
Q109	8-729-922-37	TRANSISTOR 2SD2144S-UVW	
Q110	8-729-203-06	TRANSISTOR 2SK30A-GR2	
Q111	8-729-203-06	TRANSISTOR 2SK30A-GR2	
Q112	8-729-922-37	TRANSISTOR 2SD2144S-UVW	
Q113	8-729-922-37	TRANSISTOR 2SD2144S-UVW	
Q114	8-729-922-37	TRANSISTOR 2SD2144S-UVW	
Q115	8-729-922-37	TRANSISTOR 2SD2144S-UVW	
Q116	8-729-922-37	TRANSISTOR 2SD2144S-UVW	
Q201	8-729-922-37	TRANSISTOR 2SD2144S-UVW	
Q202	8-729-922-37	TRANSISTOR 2SD2144S-UVW	
Q203	8-729-203-06	TRANSISTOR 2SK30A-GR2	
Q204	8-729-203-06	TRANSISTOR 2SK30A-GR2	
Q205	8-729-203-06	TRANSISTOR 2SK30A-GR2	

The components identified by mark △ or dotted line with mark △ are critical for safety. Replace only with part number specified.

Ref. No.	Part No.	Description	Remark
Q206	8-729-203-06	TRANSISTOR 2SK30A-GR2	
Q207	8-729-922-37	TRANSISTOR 2SD2144S-UVW	
Q208	8-729-922-37	TRANSISTOR 2SD2144S-UVW	
Q209	8-729-922-37	TRANSISTOR 2SD2144S-UVW	
Q210	8-729-203-06	TRANSISTOR 2SK30A-GR2	
Q211	8-729-203-06	TRANSISTOR 2SK30A-GR2	
Q212	8-729-922-37	TRANSISTOR 2SD2144S-UVW	
Q213	8-729-922-37	TRANSISTOR 2SD2144S-UVW	
Q214	8-729-922-37	TRANSISTOR 2SD2144S-UVW	
Q215	8-729-922-37	TRANSISTOR 2SD2144S-UVW	
Q216	8-729-922-37	TRANSISTOR 2SD2144S-UVW	
Q501	8-729-141-89	TRANSISTOR 2SD1585-LK	
Q502	8-729-141-83	TRANSISTOR 2SB1094-LK	
Q503	8-729-224-62	TRANSISTOR 2SK246-GR	
Q504	8-729-224-62	TRANSISTOR 2SK246-GR	
Q505	8-729-620-05	TRANSISTOR 2SC2603-EF	
Q506	8-729-119-76	TRANSISTOR 2SA1175-HFE	
Q507	8-729-620-05	TRANSISTOR 2SC2603-EF	
Q508	8-729-119-76	TRANSISTOR 2SA1175-HFE	
Q509	8-729-922-37	TRANSISTOR 2SD2144S-UVW	
Q510	8-729-922-37	TRANSISTOR 2SD2144S-UVW	
Q511	8-729-900-89	TRANSISTOR DTC144ES	
Q514	8-729-900-89	TRANSISTOR DTC144ES	
Q515	8-729-922-37	TRANSISTOR 2SD2144S-UVW	
Q516	8-729-922-37	TRANSISTOR 2SD2144S-UVW	
Q519	8-729-900-61	TRANSISTOR DTA114ES	
Q520	8-729-900-89	TRANSISTOR DTC144ES	
Q521	8-729-900-61	TRANSISTOR DTA114ES	
Q522	8-729-900-80	TRANSISTOR DTC114ES	
Q523	8-729-900-80	TRANSISTOR DTC114ES	
Q524	8-729-900-80	TRANSISTOR DTC114ES	
Q525	8-729-900-80	TRANSISTOR DTC114ES	
Q526	8-729-281-52	TRANSISTOR 2SC1815-Y	
Q527	8-729-194-57	TRANSISTOR 2SC945-P	
Q528	8-729-194-57	TRANSISTOR 2SC945-P	
< RESISTOR >			
R1	1-216-013-00	METAL CHIP 33 5% 1/10W	
R2	1-216-675-11	METAL CHIP 10K 0.5% 1/10W	
R3	1-216-681-11	METAL CHIP 18K 0.5% 1/10W	
R4	1-218-774-11	METAL CHIP 820K 0.5% 1/10W	
R5	1-216-668-11	METAL CHIP 5.1K 0.5% 1/10W	
R6	1-216-656-11	METAL CHIP 1.6K 0.5% 1/10W	
R7	1-216-657-11	METAL CHIP 1.8K 0.5% 1/10W	
R8	1-216-065-00	METAL CHIP 4.7K 5% 1/10W	
R9	1-216-058-00	METAL GLAZE 2.4K 5% 1/10W	
R10	1-216-654-11	METAL CHIP 1.3K 0.5% 1/10W	
R11	1-216-013-00	METAL CHIP 33 5% 1/10W	
R12	1-216-017-00	METAL CHIP 47 5% 1/10W	

Ref. No.	Part No.	Description	Remark
R13	1-216-051-00	METAL CHIP 1.2K 5% 1/10W	
R14	1-216-065-00	METAL CHIP 4.7K 5% 1/10W	
R15	1-216-058-00	METAL GLAZE 2.4K 5% 1/10W	
R16	1-216-013-00	METAL CHIP 33 5% 1/10W	
R17	1-216-017-00	METAL CHIP 47 5% 1/10W	
R18	1-216-055-00	METAL CHIP 1.8K 5% 1/10W	
R19	1-216-656-11	METAL CHIP 1.6K 0.5% 1/10W	
R20	1-216-668-11	METAL CHIP 5.1K 0.5% 1/10W	
R21	1-218-774-11	METAL CHIP 820K 0.5% 1/10W	
R22	1-216-655-11	METAL CHIP 1.5K 0.5% 1/10W	
R23	1-216-678-11	METAL CHIP 13K 0.5% 1/10W	
R24	1-216-673-11	METAL CHIP 8.2K 0.5% 1/10W	
R25	1-216-675-11	METAL CHIP 10K 0.5% 1/10W	
R26	1-216-676-11	METAL CHIP 11K 0.5% 1/10W	
R27	1-216-668-11	METAL CHIP 5.1K 0.5% 1/10W	
R28	1-216-697-11	METAL CHIP 82K 0.5% 1/10W	
R29	1-216-668-11	METAL CHIP 5.1K 0.5% 1/10W	
R30	1-216-660-11	METAL CHIP 2.4K 0.5% 1/10W	
R31	1-216-680-11	METAL CHIP 16K 0.5% 1/10W	
R32	1-216-685-11	METAL CHIP 27K 0.5% 1/10W	
R33	1-216-080-00	METAL CHIP 20K 5% 1/10W	
R34	1-216-684-11	METAL CHIP 24K 0.5% 1/10W	
R35	1-216-084-00	METAL CHIP 30K 5% 1/10W	
R36	1-216-084-00	METAL CHIP 30K 5% 1/10W	
R37	1-216-074-00	METAL CHIP 11K 5% 1/10W	
R38	1-216-086-00	METAL GLAZE 36K 5% 1/10W	
R39	1-216-066-00	METAL CHIP 5.1K 5% 1/10W	
R40	1-216-084-00	METAL CHIP 30K 5% 1/10W	
R41	1-216-078-00	METAL GLAZE 16K 5% 1/10W	
R42	1-216-071-00	METAL CHIP 8.2K 5% 1/10W	
R43	1-216-081-00	METAL CHIP 22K 5% 1/10W	
R44	1-216-689-11	METAL CHIP 39K 0.5% 1/10W	
R45	1-216-689-11	METAL CHIP 39K 0.5% 1/10W	
R51	1-216-669-11	METAL CHIP 5.6K 0.5% 1/10W	
R52	1-216-663-11	METAL CHIP 3.3K 0.5% 1/10W	
R55	1-216-658-11	METAL CHIP 2K 0.5% 1/10W	
R101	1-259-476-11	CARBON 100K 5% 1/6W	
R102	1-247-702-11	CARBON 150 5% 1/4W	
R103	1-247-722-11	CARBON 5.6K 5% 1/4W	
R104	1-249-603-11	CARBON 130K 5% 1/4W	
R105	1-259-468-11	CARBON 47K 5% 1/6W	
R106	1-247-717-11	CARBON 2.2K 5% 1/4W	
R107	1-259-435-11	CARBON 2K 5% 1/6W	
R108	1-249-429-11	CARBON 10K 5% 1/4W	
R109	1-259-436-11	CARBON 2.2K 5% 1/6W	
R110	1-259-468-11	CARBON 47K 5% 1/6W	
R111	1-247-710-11	CARBON 560 5% 1/4W	
R112	1-247-725-11	CARBON 10K 5% 1/4W	
R113	1-247-719-11	CARBON 3.3K 5% 1/4W	

AUDIO

DOLBY S

Ref. No.	Part No.	Description	Remark
R114	1-247-719-11	CARBON	3.3K 5% 1/4W
R115	1-259-500-11	CARBON	1M 5% 1/6W
R116	1-259-422-11	CARBON	560 5% 1/6W
R117	1-259-460-11	CARBON	22K 5% 1/6W
R118	1-259-449-11	CARBON	7.5K 5% 1/6W
R119	1-259-424-11	CARBON	680 5% 1/6W
R120	1-259-451-11	CARBON	9.1K 5% 1/6W
R121	1-249-429-11	CARBON	10K 5% 1/4W
R122	1-249-940-11	CARBON	5.1K 1% 1/4W
R123	1-247-721-11	CARBON	4.7K 5% 1/4W
R124	1-249-949-11	CARBON	12K 1% 1/4W
R125	1-247-715-11	CARBON	1.5K 5% 1/4W
R126	1-247-715-11	CARBON	1.5K 5% 1/4W
R127	1-249-913-11	CARBON	390 1% 1/4W
R128	1-259-468-11	CARBON	47K 5% 1/6W
R129	1-247-716-11	CARBON	1.8K 5% 1/4W
R130	1-249-421-11	CARBON	2.2K 5% 1/4W
R131	1-259-468-11	CARBON	47K 5% 1/6W
R132	1-259-452-11	CARBON	10K 5% 1/6W
R133	1-215-441-00	METAL	6.8K 1% 1/6W
R134	1-215-465-00	METAL	68K 1% 1/6W
R135	1-215-448-00	METAL	13K 1% 1/6W
R136	1-215-471-00	METAL	120K 1% 1/6W
R137	1-215-403-00	METAL	180 1% 1/6W
R138	1-215-473-00	METAL	150K 1% 1/6W
R139	1-259-468-11	CARBON	47K 5% 1/6W
R140	1-249-433-11	CARBON	22K 5% 1/4W
R141	1-249-417-11	CARBON	1K 5% 1/4W
R142	1-249-437-11	CARBON	47K 5% 1/4W
R143	1-249-427-11	CARBON	6.8K 5% 1/4W
R144	1-259-452-11	CARBON	10K 5% 1/6W
R145	1-259-440-11	CARBON	3.3K 5% 1/6W
R146	1-259-460-11	CARBON	22K 5% 1/6W
R147	1-247-704-11	CARBON	220 5% 1/4W
R148	1-247-713-11	CARBON	1K 5% 1/4W
R149	1-249-461-11	CARBON	18K 5% 1/4W
R150	1-259-476-11	CARBON	100K 5% 1/6W
R151	1-259-448-11	CARBON	6.8K 5% 1/6W
R152	1-259-442-11	CARBON	3.9K 5% 1/6W
R153	1-259-449-11	CARBON	7.5K 5% 1/6W
R154	1-259-468-11	CARBON	47K 5% 1/6W
R155	1-259-468-11	CARBON	47K 5% 1/6W
R156	1-247-128-00	CARBON	750 5% 1/4W
R157	1-247-725-11	CARBON	10K 5% 1/4W
R158	1-247-719-11	CARBON	3.3K 5% 1/4W
R159	1-247-719-11	CARBON	3.3K 5% 1/4W
R160	1-259-500-11	CARBON	1M 5% 1/6W
R161	1-259-422-11	CARBON	560 5% 1/6W
R162	1-259-460-11	CARBON	22K 5% 1/6W

Ref. No.	Part No.	Description	Remark
R163	1-259-449-11	CARBON	7.5K 5% 1/6W
R164	1-259-424-11	CARBON	680 5% 1/6W
R165	1-259-451-11	CARBON	9.1K 5% 1/6W
R166	1-259-476-11	CARBON	100K 5% 1/6W
R167	1-249-429-11	CARBON	10K 5% 1/4W
R168	1-247-193-00	CARBON	22K 1% 1/4W
R169	1-247-193-00	CARBON	22K 1% 1/4W
R170	1-247-719-11	CARBON	3.3K 5% 1/4W
R171	1-249-941-11	CARBON	5.6K 1% 1/4W
R172	1-259-476-11	CARBON	100K 5% 1/6W
R173	1-259-444-11	CARBON	4.7K 5% 1/6W
R174	1-259-450-11	CARBON	8.2K 5% 1/6W
R175	1-247-725-11	CARBON	10K 5% 1/4W
R176	1-259-444-11	CARBON	4.7K 5% 1/6W
R177	1-259-500-11	CARBON	1M 5% 1/6W
R178	1-259-460-11	CARBON	22K 5% 1/6W
R179	1-259-440-11	CARBON	3.3K 5% 1/6W
R180	1-259-448-11	CARBON	6.8K 5% 1/6W
R181	1-249-421-11	CARBON	2.2K 5% 1/4W
R182	1-259-461-11	CARBON	24K 5% 1/6W
R183	1-249-429-11	CARBON	10K 5% 1/4W
R184	1-259-468-11	CARBON	47K 5% 1/6W
R185	1-259-436-11	CARBON	2.2K 5% 1/6W
R186	1-259-476-11	CARBON	100K 5% 1/6W
R187	1-259-469-11	CARBON	51K 5% 1/6W
R188	1-249-782-11	CARBON	150 5% 1/6W
R190	1-249-782-11	CARBON	150 5% 1/6W
R191	1-259-450-11	CARBON	8.2K 5% 1/6W
R192	1-259-445-11	CARBON	5.1K 5% 1/6W
R193	1-259-407-91	CARBON	130 5% 1/6W
R194	1-259-444-11	CARBON	4.7K 5% 1/6W
R195	1-259-442-11	CARBON	3.9K 5% 1/6W
R196	1-249-429-11	CARBON	10K 5% 1/4W
R197	1-249-429-11	CARBON	10K 5% 1/4W
R198	1-249-429-11	CARBON	10K 5% 1/4W
R199	1-247-721-11	CARBON	4.7K 5% 1/4W
R201	1-259-476-11	CARBON	100K 5% 1/6W
R202	1-247-702-11	CARBON	150 5% 1/4W
R203	1-247-722-11	CARBON	5.6K 5% 1/4W
R204	1-249-603-11	CARBON	130K 5% 1/4W
R205	1-259-468-11	CARBON	47K 5% 1/6W
R206	1-247-717-11	CARBON	2.2K 5% 1/4W
R207	1-259-435-11	CARBON	2K 5% 1/6W
R208	1-249-429-11	CARBON	10K 5% 1/4W
R209	1-259-436-11	CARBON	2.2K 5% 1/6W
R210	1-259-468-11	CARBON	47K 5% 1/6W
R211	1-247-710-11	CARBON	560 5% 1/4W
R212	1-247-725-11	CARBON	10K 5% 1/4W
R213	1-247-719-11	CARBON	3.3K 5% 1/4W

AUDIO

DOLBY S

Ref. No.	Part No.	Description			Remark
R214	1-247-719-11	CARBON	3.3K	5%	1/4W
R215	1-259-500-11	CARBON	1M	5%	1/6W
R216	1-259-422-11	CARBON	560	5%	1/6W
R217	1-259-460-11	CARBON	22K	5%	1/6W
R218	1-259-449-11	CARBON	7.5K	5%	1/6W
R219	1-259-424-11	CARBON	680	5%	1/6W
R220	1-259-451-11	CARBON	9.1K	5%	1/6W
R221	1-249-429-11	CARBON	10K	5%	1/4W
R222	1-249-940-11	CARBON	5.1K	1%	1/4W
R223	1-247-721-11	CARBON	4.7K	5%	1/4W
R224	1-249-949-11	CARBON	12K	1%	1/4W
R225	1-247-715-11	CARBON	1.5K	5%	1/4W
R226	1-247-715-11	CARBON	1.5K	5%	1/4W
R227	1-249-913-11	CARBON	390	1%	1/4W
R228	1-259-468-11	CARBON	47K	5%	1/6W
R229	1-247-716-11	CARBON	1.8K	5%	1/4W
R230	1-249-421-11	CARBON	2.2K	5%	1/4W
R231	1-259-468-11	CARBON	47K	5%	1/6W
R232	1-259-452-11	CARBON	10K	5%	1/6W
R233	1-215-441-00	METAL	6.8K	1%	1/6W
R234	1-215-465-00	METAL	68K	1%	1/6W
R235	1-215-448-00	METAL	13K	1%	1/6W
R236	1-215-471-00	METAL	120K	1%	1/6W
R237	1-215-403-00	METAL	180	1%	1/6W
R238	1-215-473-00	METAL	150K	1%	1/6W
R239	1-259-468-11	CARBON	47K	5%	1/6W
R240	1-249-433-11	CARBON	22K	5%	1/4W
R241	1-249-417-11	CARBON	1K	5%	1/4W
R242	1-249-437-11	CARBON	47K	5%	1/4W
R243	1-249-427-11	CARBON	6.8K	5%	1/4W
R244	1-259-452-11	CARBON	10K	5%	1/6W
R245	1-259-440-11	CARBON	3.3K	5%	1/6W
R246	1-259-460-11	CARBON	22K	5%	1/6W
R247	1-247-704-11	CARBON	220	5%	1/4W
R248	1-247-713-11	CARBON	1K	5%	1/4W
R249	1-249-461-11	CARBON	18K	5%	1/4W
R250	1-259-476-11	CARBON	100K	5%	1/6W
R251	1-259-448-11	CARBON	6.8K	5%	1/6W
R252	1-259-442-11	CARBON	3.9K	5%	1/6W
R253	1-259-449-11	CARBON	7.5K	5%	1/6W
R254	1-259-468-11	CARBON	47K	5%	1/6W
R255	1-259-468-11	CARBON	47K	5%	1/6W
R256	1-247-128-00	CARBON	750	5%	1/4W
R257	1-247-725-11	CARBON	10K	5%	1/4W
R258	1-247-719-11	CARBON	3.3K	5%	1/4W
R259	1-247-719-11	CARBON	3.3K	5%	1/4W
R260	1-259-500-11	CARBON	1M	5%	1/6W
R261	1-259-422-11	CARBON	560	5%	1/6W
R262	1-259-460-11	CARBON	22K	5%	1/6W

Ref. No.	Part No.	Description			Remark
R263	1-259-449-11	CARBON	7.5K	5%	1/6W
R264	1-259-424-11	CARBON	680	5%	1/6W
R265	1-259-451-11	CARBON	9.1K	5%	1/6W
R266	1-259-476-11	CARBON	100K	5%	1/6W
R267	1-249-429-11	CARBON	10K	5%	1/4W
R268	1-247-193-00	CARBON	22K	1%	1/4W
R269	1-247-193-00	CARBON	22K	1%	1/4W
R270	1-247-719-11	CARBON	3.3K	5%	1/4W
R271	1-249-941-11	CARBON	5.6K	1%	1/4W
R272	1-259-476-11	CARBON	100K	5%	1/6W
R273	1-259-444-11	CARBON	4.7K	5%	1/6W
R274	1-259-450-11	CARBON	8.2K	5%	1/6W
R275	1-247-725-11	CARBON	10K	5%	1/4W
R276	1-259-444-11	CARBON	4.7K	5%	1/6W
R277	1-259-500-11	CARBON	1M	5%	1/6W
R278	1-259-460-11	CARBON	22K	5%	1/6W
R279	1-259-440-11	CARBON	3.3K	5%	1/6W
R280	1-259-448-11	CARBON	6.8K	5%	1/6W
R281	1-249-421-11	CARBON	2.2K	5%	1/4W
R282	1-259-461-11	CARBON	24K	5%	1/6W
R283	1-249-429-11	CARBON	10K	5%	1/4W
R284	1-259-468-11	CARBON	47K	5%	1/6W
R285	1-259-436-11	CARBON	2.2K	5%	1/6W
R286	1-259-476-11	CARBON	100K	5%	1/6W
R287	1-259-469-11	CARBON	51K	5%	1/6W
R288	1-249-782-11	CARBON	150	5%	1/6W
R290	1-249-782-11	CARBON	150	5%	1/6W
R291	1-259-450-11	CARBON	8.2K	5%	1/6W
R292	1-259-445-11	CARBON	5.1K	5%	1/6W
R293	1-259-407-91	CARBON	130	5%	1/6W
R294	1-259-444-11	CARBON	4.7K	5%	1/6W
R295	1-259-442-11	CARBON	3.9K	5%	1/6W
R296	1-249-429-11	CARBON	10K	5%	1/4W
R297	1-249-429-11	CARBON	10K	5%	1/4W
R298	1-249-429-11	CARBON	10K	5%	1/4W
R299	1-247-721-11	CARBON	4.7K	5%	1/4W
R301	1-249-435-11	CARBON	33K	5%	1/4W
R302	1-249-426-11	CARBON	5.6K	5%	1/4W
R303	1-247-883-00	CARBON	150K	5%	1/4W
△R304	1-212-857-00	FUSIBLE	10	5%	1/4W F
R307	1-259-440-11	CARBON	3.3K	5%	1/6W
R308	1-259-468-11	CARBON	47K	5%	1/6W
R309	1-249-962-11	CARBON	43K	1%	1/4W
R310	1-259-468-11	CARBON	47K	5%	1/6W
R401	1-249-435-11	CARBON	33K	5%	1/4W
R402	1-249-426-11	CARBON	5.6K	5%	1/4W
R403	1-247-883-00	CARBON	150K	5%	1/4W
△R404	1-212-857-00	FUSIBLE	10	5%	1/4W F
R407	1-259-440-11	CARBON	3.3K	5%	1/6W

The components identified by mark △ or dotted line with mark. △ are critical for safety. Replace only with part number specified.

AUDIO

DOLBY S

Ref. No.	Part No.	Description	Remark		
R408	1-259-468-11	CARBON	47K	5%	1/6W
R409	1-249-962-11	CARBON	43K	1%	1/4W
R410	1-259-468-11	CARBON	47K	5%	1/6W
R501	1-247-704-11	CARBON	220	5%	1/4W
R502	1-247-704-11	CARBON	220	5%	1/4W
R503	1-247-717-11	CARBON	2.2K	5%	1/4W
R504	1-247-717-11	CARBON	2.2K	5%	1/4W
R505	1-247-717-11	CARBON	2.2K	5%	1/4W
R507	1-247-706-11	CARBON	330	5%	1/4W
R508	1-249-926-11	CARBON	1.3K	5%	1/4W
R509	1-249-556-11	CARBON	1.5K	5%	1/4W
R510	1-249-556-11	CARBON	1.5K	5%	1/4W
R511	1-249-433-11	CARBON	22K	5%	1/4W
R512	1-249-437-11	CARBON	47K	5%	1/4W
R513	1-249-433-11	CARBON	22K	5%	1/4W
R514	1-249-429-11	CARBON	10K	5%	1/4W
R515	1-215-472-00	METAL	130K	1%	1/6W
R516	1-249-429-11	CARBON	10K	5%	1/4W
R517	1-249-437-11	CARBON	47K	5%	1/4W
R518	1-249-417-11	CARBON	1K	5%	1/4W
R519	1-247-885-00	CARBON	180K	5%	1/4W
R520	1-249-433-11	CARBON	22K	5%	1/4W
R521	1-249-413-11	CARBON	470	5%	1/4W
R522	1-249-413-11	CARBON	470	5%	1/4W
R523	1-249-432-11	CARBON	18K	5%	1/4W
R524	1-249-433-11	CARBON	22K	5%	1/4W
R527	1-249-433-11	CARBON	22K	5%	1/4W
R528	1-249-421-11	CARBON	2.2K	5%	1/4W
R530	1-249-429-11	CARBON	10K	5%	1/4W
R531	1-249-433-11	CARBON	22K	5%	1/4W
R532	1-249-437-11	CARBON	47K	5%	1/4W
R533	1-247-856-00	CARBON	11K	5%	1/4W
R534	1-249-397-11	CARBON	22	5%	1/4W
R535	1-249-406-11	CARBON	120	5%	1/4W
R536	1-247-856-00	CARBON	11K	5%	1/4W
R537	1-249-437-11	CARBON	47K	5%	1/4W
R538	1-249-432-11	CARBON	18K	5%	1/4W
R539	1-249-397-11	CARBON	22	5%	1/4W
R540	1-249-406-11	CARBON	120	5%	1/4W
R541	1-249-432-11	CARBON	18K	5%	1/4W
R542	1-247-887-00	CARBON	220K	5%	1/4W
R543	1-247-887-00	CARBON	220K	5%	1/4W
R544	1-249-407-11	CARBON	150	5%	1/4W
R547	1-249-437-11	CARBON	47K	5%	1/4W
R548	1-249-429-11	CARBON	10K	5%	1/4W
R549	1-249-437-11	CARBON	47K	5%	1/4W
R550	1-249-437-11	CARBON	47K	5%	1/4W
R551	1-249-437-11	CARBON	47K	5%	1/4W
R552	1-249-421-11	CARBON	2.2K	5%	1/4W

Ref. No.	Part No.	Description	Remark		
R553	1-249-441-11	CARBON	100K	5%	1/4W
R554	1-249-413-11	CARBON	470	5%	1/4W
R555	1-249-417-11	CARBON	1K	5%	1/4W
R556	1-249-421-11	CARBON	2.2K	5%	1/4W
R557	1-249-417-11	CARBON	1K	5%	1/4W
R558	1-249-421-11	CARBON	2.2K	5%	1/4W
R560	1-249-433-11	CARBON	22K	5%	1/4W
R561	1-249-427-11	CARBON	6.8K	5%	1/4W
R562	1-249-440-11	CARBON	82K	5%	1/4W
R563	1-249-440-11	CARBON	82K	5%	1/4W
△R564	1-212-853-00	FUSIBLE	6.8	5%	1/4W F
△R565	1-212-853-00	FUSIBLE	6.8	5%	1/4W F
R566	1-249-381-11	CARBON	1	5%	1/4W
R567	1-249-437-11	CARBON	47K	5%	1/4W
R568	1-215-472-00	METAL	130K	1%	1/6W
R569	1-249-429-11	CARBON	10K	5%	1/4W
R570	1-249-429-11	CARBON	10K	5%	1/4W
< VARIABLE RESISTOR >					
RV101	1-237-192-11	RES, ADJ, CARBON	5K		
RV102	1-241-631-11	RES, ADJ, CARBON	22K		
RV103	1-237-192-11	RES, ADJ, CARBON	5K		
RV104	1-241-631-11	RES, ADJ, CARBON	22K		
RV201	1-237-192-11	RES, ADJ, CARBON	5K		
RV202	1-241-631-11	RES, ADJ, CARBON	22K		
RV203	1-237-192-11	RES, ADJ, CARBON	5K		
RV204	1-241-631-11	RES, ADJ, CARBON	22K		
RV501	1-223-264-11	RES, VAR, CARBON	50K/50K		(BALANCE)
RV502	1-223-265-11	RES, VAR, CARBON	20K/20K		(REC LEVEL)
RV503	1-238-840-21	RES, VAR, CARBON	5K/5K		(CAL REC LEVEL)
RV504	1-241-336-11	RES, VAR, CARBON	20K/20K		(PHONE LEVEL)
RV505	1-241-631-11	RES, ADJ, CARBON	22K		
RV506	1-241-629-11	RES, ADJ, CARBON	4.7K		
RV507	1-238-009-11	RES, ADJ, CARBON	220		
RV508	1-238-009-11	RES, ADJ, CARBON	220		
< SWITCH >					
S501	1-692-375-11	SWITCH, PUSH (1 KEY) (DIRECT)			
S502	1-572-589-11	SWITCH, ROTARY (REC EQ CAL)			
< TRANSFORMER >					
T101	1-433-384-11	TRANSFORMER, BIAS OSCILLATOR			
T201	1-433-384-11	TRANSFORMER, BIAS OSCILLATOR			
T501	1-433-359-11	TRANSFORMER, BIAS OSCILLATION			

The components identified by mark △ or dotted line with mark △ are critical for safety. Replace only with part number specified.

AUDIO

DOLBY S

CAPSTAN

COMPARATOR

MD

Ref.No.	Part No.	Description	Remark
		< TEST PIN >	
* TP501	1-564-506-11	PLUG, CONNECTOR 3P	
* TP502	1-564-506-11	PLUG, CONNECTOR 3P	
* TP503	1-564-505-41	PLUG, CONNECTOR 2P	

	A-2006-154-A	CAPSTAN BOARD, COMPLETE	

		< CAPACITOR >	
C905	1-124-779-00	ELECT CHIP 10uF	20% 16V
C906	1-135-091-00	TANTALUM CHIP 1uF	20% 16V
C907	1-163-077-00	CERAMIC CHIP 0.1uF	10% 25V
C908	1-163-077-00	CERAMIC CHIP 0.1uF	10% 25V
C909	1-163-077-00	CERAMIC CHIP 0.1uF	10% 25V
C910	1-163-205-00	CERAMIC CHIP 0.001uF	5% 50V
C911	1-124-779-00	ELECT CHIP 10uF	20% 16V
		< HOLE ELEMENT >	
H901	8-759-100-96	HOLE ELEMENT uPC4558G2	
H902	8-759-100-96	HOLE ELEMENT uPC4558G2	
H903	8-759-100-96	HOLE ELEMENT uPC4558G2	
		< IC >	
IC902	8-752-017-40	IC CX20174	
		< JUMPER RESISTOR >	
JR902	1-216-296-00	METAL CHIP 0 5%	1/8W
JR903	1-216-296-00	METAL CHIP 0 5%	1/8W
JR904	1-216-296-00	METAL CHIP 0 5%	1/8W
JR905	1-216-296-00	METAL CHIP 0 5%	1/8W
		< RESISTOR >	
R907	1-216-242-00	METAL GLAZE 68K 5%	1/8W
R908	1-216-246-00	METAL GLAZE 100K 5%	1/8W
R909	1-216-246-00	METAL GLAZE 100K 5%	1/8W
R910	1-216-238-00	METAL GLAZE 47K 5%	1/8W
R911	1-216-182-00	METAL GLAZE 220 5%	1/8W
R912	1-216-182-00	METAL GLAZE 220 5%	1/8W
R913	1-216-150-00	METAL GLAZE 10 5%	1/8W
R914	1-216-150-00	METAL GLAZE 10 5%	1/8W
R915	1-216-150-00	METAL GLAZE 10 5%	1/8W

* 1-632-746-11		COMPARATOR BOARD	

		< CAPACITOR >	
C951	1-136-157-00	FILM 0.022uF	5% 50V

Ref.No.	Part No.	Description	Remark
C952	1-124-282-00	ELECT 22uF	20% 25V
C953	1-124-478-11	ELECT 100uF	20% 25V
C954	1-124-477-11	ELECT 47uF	20% 25V
C955	1-162-203-31	CERAMIC 15PF	5% 50V
C956	1-162-203-31	CERAMIC 15PF	5% 50V
C957	1-136-159-00	FILM 0.033uF	5% 50V
		< CONNECTOR >	
* CN951	1-564-718-11	PIN, CONNECTOR (SMALL TYPE) 2P	
* CN952	1-564-518-11	PLUG, CONNECTOR 3P	
		< IC >	
IC951	8-759-145-58	IC uPC4558C	
IC952	8-759-201-58	IC TC9142P	
		< RESISTOR >	
R951	1-249-413-11	CARBON 470 5%	1/4W
R952	1-249-413-11	CARBON 470 5%	1/4W
R953	1-247-881-00	CARBON 120K 5%	1/4W
R954	1-247-881-00	CARBON 120K 5%	1/4W
R955	1-249-429-11	CARBON 10K 5%	1/4W
R956	1-249-417-11	CARBON 1K 5%	1/4W
R957	1-249-417-11	CARBON 1K 5%	1/4W
R958	1-247-891-00	CARBON 330K 5%	1/4W
R959	1-247-901-11	CARBON 820K 5%	1/4W
R960	1-249-441-11	CARBON 100K 5%	1/4W
		< VIBRATOR >	
X951	1-577-615-11	VIBRATOR, CRYSTAL (4.9406MHz)	

* 1-632-740-11		MD BOARD	

3-356-631-01		HOLDER (SENSOR)	
		< CONNECTOR >	
CN1001	1-506-615-11	PIN, CONNECTOR 9P	
CN1002	1-564-501-11	PIN, CONNECTOR 8P	
		< PHOTO INTERRUPTER >	
IC1001	8-749-920-97	PHOTO INTERRUPTER GP2S22B	
IC1002	8-749-920-97	PHOTO INTERRUPTER GP2S22B	
		< RESISTOR >	
R1001	1-249-408-11	CARBON 180 5%	1/4W
R1002	1-249-408-11	CARBON 180 5%	1/4W

MD REEL MOTOR SYSTEM CONTROL

Ref. No.	Part No.	Description	Remark
< SWITCH >			
S1002	1-570-953-11	SWITCH, PUSH (1 KEY) (DOOR)	
S1003	1-571-958-11	SWITCH, PUSH (1 KEY) (CLOSE)	
S1004	1-572-126-11	SWITCH, PUSH (1 KEY) (OPEN)	
S1005	1-572-125-11	SWITCH, LEAF (FWD TAB)	
S1006	1-572-202-11	SWITCH, LEAF (HALF)	
S1007	1-572-125-11	SWITCH, LEAF (METAL)	
S1008	1-572-125-11	SWITCH, LEAF (70u)	
< TERMINAL >			
* TB1001	1-694-018-11	TERMINAL (5P)	

* 1-632-741-11		REEL MOTOR BOARD	

< CAPACITOR >			
C1051	1-124-907-11	ELECT 10uF 20% 50V	
C1052	1-124-907-11	ELECT 10uF 20% 50V	
C1053	1-164-159-11	CERAMIC 0.1uF 50V	
< CONNECTOR >			
* CN1051	1-564-499-11	PIN, CONNECTOR 6P	
* CN1052	1-564-718-11	PIN, CONNECTOR (SMALL TYPE) 2P	
* CN1053	1-564-718-11	PIN, CONNECTOR (SMALL TYPE) 2P	
< MOTOR >			
M1001	X-3356-638-1	MOTOR (REEL R) ASSY	
M1002	X-3356-604-1	MOTOR (ASSIST) ASSY	
< RESISTOR >			
R1051	1-249-412-11	CARBON 390 5% 1/4W	

* A-2007-027-A		SYSTEM CONTROL BOARD, COMPLETE	

* 1-533-213-11		HOLDER, FUSE	
* 1-533-213-31		HOLDER, FUSE	
* 3-309-144-31		HEAT SINK	
* 9-911-844-XX		CUSHION	
* 3-356-925-01		HEAT SINK	
* 3-362-478-11		HOLDER (T), LED	
* 3-385-607-01		HOLDER, FL TUBE	
* 4-880-403-21		HEAT SINK	
* 4-942-204-01		PLATE, GROUND	
* 7-685-871-01		SCREW +BVTT 3X6 (S)	

Ref. No.	Part No.	Description	Remark
< CAPACITOR >			
C001	1-161-744-00	CERAMIC 0.01uF 400V	
C601	1-124-443-00	ELECT 100uF 20% 10V	
C602	1-164-159-11	CERAMIC 0.1uF 50V	
C603	1-162-294-31	CERAMIC 0.001uF 10% 50V	
C604	1-162-294-31	CERAMIC 0.001uF 10% 50V	
C701	1-136-177-00	FILM 1uF 5% 50V	
C702	1-136-165-00	FILM 0.1uF 5% 50V	
C703	1-124-636-00	ELECT 3300uF 20% 25V	
C704	1-124-636-00	ELECT 3300uF 20% 25V	
C705	1-124-927-11	ELECT 4.7uF 20% 100V	
C706	1-126-105-11	ELECT 1000uF 20% 35V	
C707	1-124-887-00	ELECT 3300uF 20% 16V	
C708	1-124-903-11	ELECT 1uF 20% 50V	
C709	1-124-471-00	ELECT 1000uF 20% 6.3V	
C710	1-124-927-11	ELECT 4.7uF 20% 100V	
C711	1-124-927-11	ELECT 4.7uF 20% 100V	
C712	1-162-211-31	CERAMIC 33PF 5% 50V	
C713	1-124-473-11	ELECT 1000uF 20% 10V	
C714	1-126-955-11	ELECT 4700uF 20% 35V	
C715	1-124-927-11	ELECT 4.7uF 20% 100V	
C716	1-124-556-11	ELECT 2200uF 20% 16V	
C717	1-124-122-11	ELECT 100uF 20% 50V	
C718	1-124-477-11	ELECT 47uF 20% 25V	
C719	1-164-159-11	CERAMIC 0.1uF 50V	
C801	1-124-907-11	ELECT 10uF 20% 50V	
C802	1-124-927-11	ELECT 4.7uF 20% 100V	
C803	1-124-443-00	ELECT 100uF 20% 10V	
C804	1-124-472-11	ELECT 470uF 20% 10V	
C805	1-164-159-11	CERAMIC 0.1uF 50V	
C806	1-164-159-11	CERAMIC 0.1uF 50V	
C807	1-124-477-11	ELECT 47uF 20% 25V	
C851	1-124-234-00	ELECT 22uF 20% 16V	
C852	1-124-907-11	ELECT 10uF 20% 50V	
C853	1-124-925-11	ELECT 2.2uF 20% 100V	
C854	1-124-927-11	ELECT 4.7uF 20% 100V	
< CONNECTOR >			
* CN001	1-580-230-31	PIN, CONNECTOR (PC BOARD) 2P	
* CN002	1-568-226-11	PIN, CONNECTOR 2P	
* CN701	1-564-506-11	PLUG, CONNECTOR 3P	
* CN702	1-564-511-11	PLUG, CONNECTOR 8P	
* CN801	1-564-339-51	PIN, CONNECTOR 5P	
* CN802	1-506-503-11	PIN, CONNECTOR 9P	
* CN803	1-564-341-51	PIN, CONNECTOR 7P	

SYSTEM CONTROL

Ref. No.	Part No.	Description	Remark
< COMPOSITION CIRCUIT BLOCK >			
CP601	1-232-881-11	COMPOSITION CIRCUIT BLOCK 100k X 6	
CP602	1-236-985-11	COMPOSITION CIRCUIT BLOCK 100k X 9	
CP801	1-236-984-11	COMPOSITION CIRCUIT BLOCK 4.7k X 11	
< DIODE >			
D601	8-719-301-44	LED SEL2410E-D (PLAY)	
D602	8-719-301-61	LED SEL2910A-D (PAUSE)	
D603	8-719-301-39	LED SEL2210S-D (REC)	
D604	8-719-987-63	DIODE 1N4148M	
D605	8-719-987-63	DIODE 1N4148M	
D606	8-719-987-63	DIODE 1N4148M	
D607	8-719-987-63	DIODE 1N4148M	
D701	8-719-230-02	DIODE 30DF2	
D702	8-719-230-02	DIODE 30DF2	
D703	8-719-230-02	DIODE 30DF2	
D704	8-719-230-02	DIODE 30DF2	
D705	8-719-200-77	DIODE 10E2N	
D706	8-719-200-77	DIODE 10E2N	
D707	8-719-200-77	DIODE 10E2N	
D708	8-719-200-77	DIODE 10E2N	
D709	8-719-200-77	DIODE 10E2N	
D710	8-719-987-63	DIODE 1N4148M	
D711	8-719-933-41	DIODE HZS6C3L	
D712	8-719-933-41	DIODE HZS6C3L	
D713	8-719-200-77	DIODE 10E2N	
D714	8-719-001-79	DIODE UZL-12H1	
D715	8-719-200-77	DIODE 10E2N	
D716	8-719-200-77	DIODE 10E2N	
D717	8-719-933-41	DIODE HZS6C3L	
D801	8-719-200-77	DIODE 10E2N	
D802	8-719-987-63	DIODE 1N4148M	
D803	8-719-987-63	DIODE 1N4148M	
D804	8-719-987-63	DIODE 1N4148M	
D851	8-719-987-63	DIODE 1N4148M	
D852	8-719-987-63	DIODE 1N4148M	
D853	8-719-987-63	DIODE 1N4148M	
D855	8-719-987-63	DIODE 1N4148M	
D856	8-719-987-63	DIODE 1N4148M	
D857	8-719-987-63	DIODE 1N4148M	
D858	8-719-987-63	DIODE 1N4148M	
< FUSE >			
△F701	1-532-285-00	FUSE, TIME-LAG (T1.25AL/250V)	
< FLUORESCENT INDICATOR TUBE >			
FLT601	1-517-139-11	INDICATOR TUBE, FLUORESCENT	

Ref. No.	Part No.	Description	Remark
< IC >			
IC601	8-759-635-68	IC M50940-313SP	
IC801	8-759-635-69	IC M50964-226SP	
IC802	8-759-973-95	IC BA6219B	
IC803	8-759-822-09	IC LB1641	
IC851	8-741-100-48	IC SBX1610-59	
< TRANSISTOR >			
Q601	8-729-900-61	TRANSISTOR DTA114ES	
Q602	8-729-900-61	TRANSISTOR DTA114ES	
Q603	8-729-900-61	TRANSISTOR DTA114ES	
Q604	8-729-900-61	TRANSISTOR DTA114ES	
Q605	8-729-900-61	TRANSISTOR DTA114ES	
Q606	8-729-900-61	TRANSISTOR DTA114ES	
Q607	8-729-900-65	TRANSISTOR DTA144ES	
Q608	8-729-900-65	TRANSISTOR DTA144ES	
Q609	8-729-900-65	TRANSISTOR DTA144ES	
Q610	8-729-900-65	TRANSISTOR DTA144ES	
Q611	8-729-900-65	TRANSISTOR DTA144ES	
Q612	8-729-900-65	TRANSISTOR DTA144ES	
Q613	8-729-900-89	TRANSISTOR DTC144ES	
Q614	8-729-900-65	TRANSISTOR DTA144ES	
Q701	8-729-231-60	TRANSISTOR 2SD1406-YGR	
Q702	8-729-209-15	TRANSISTOR 2SD2012	
Q703	8-729-209-15	TRANSISTOR 2SD2012	
Q704	8-729-620-05	TRANSISTOR 2SC2603-EF	
Q705	8-729-620-05	TRANSISTOR 2SC2603-EF	
Q706	8-729-620-05	TRANSISTOR 2SC2603-EF	
Q707	8-729-620-05	TRANSISTOR 2SC2603-EF	
Q708	8-729-140-04	TRANSISTOR 2SB1116A-L	
Q709	8-729-141-32	TRANSISTOR 2SA1409-LK	
Q801	8-729-620-05	TRANSISTOR 2SC2603-EF	
Q802	8-729-620-05	TRANSISTOR 2SC2603-EF	
Q803	8-729-900-61	TRANSISTOR DTA114ES	
Q804	8-729-119-76	TRANSISTOR 2SA1175-HFE	
Q805	8-729-119-76	TRANSISTOR 2SA1175-HFE	
Q806	8-729-900-65	TRANSISTOR DTA144ES	
Q807	8-729-900-65	TRANSISTOR DTA144ES	
Q808	8-729-900-65	TRANSISTOR DTA144ES	
Q809	8-729-900-65	TRANSISTOR DTA144ES	
Q810	8-729-900-65	TRANSISTOR DTA144ES	
Q811	8-729-119-76	TRANSISTOR 2SA1175-HFE	
Q812	8-729-900-65	TRANSISTOR DTA144ES	
Q813	8-729-900-65	TRANSISTOR DTA144ES	
Q814	8-729-119-76	TRANSISTOR 2SA1175-HFE	
Q815	8-729-900-89	TRANSISTOR DTC144ES	
Q851	8-729-900-80	TRANSISTOR DTC114ES	
Q852	8-729-900-65	TRANSISTOR DTA144ES	

The components identified by mark △ or dotted line with mark △ are critical for safety. Replace only with part number specified.

SYSTEM CONTROL

Ref. No.	Part No.	Description	Remark		
Q854	8-729-900-80	TRANSISTOR	DTC114ES		
		< RESISTOR >			
R601	1-249-429-11	CARBON	10K	5%	1/4W
R602	1-249-429-11	CARBON	10K	5%	1/4W
R603	1-249-437-11	CARBON	47K	5%	1/4W
R604	1-247-903-00	CARBON	1M	5%	1/4W
R605	1-249-421-11	CARBON	2.2K	5%	1/4W
R606	1-249-421-11	CARBON	2.2K	5%	1/4W
R607	1-249-421-11	CARBON	2.2K	5%	1/4W
R608	1-249-421-11	CARBON	2.2K	5%	1/4W
R609	1-249-429-11	CARBON	10K	5%	1/4W
R610	1-249-425-11	CARBON	4.7K	5%	1/4W
R611	1-249-422-11	CARBON	2.7K	5%	1/4W
R612	1-249-424-11	CARBON	3.9K	5%	1/4W
R613	1-249-428-11	CARBON	8.2K	5%	1/4W
R614	1-249-434-11	CARBON	27K	5%	1/4W
R615	1-249-422-11	CARBON	2.7K	5%	1/4W
R616	1-249-424-11	CARBON	3.9K	5%	1/4W
R617	1-249-428-11	CARBON	8.2K	5%	1/4W
R618	1-249-434-11	CARBON	27K	5%	1/4W
R619	1-249-431-11	CARBON	15K	5%	1/4W
R620	1-249-434-11	CARBON	27K	5%	1/4W
R621	1-249-409-11	CARBON	220	5%	1/4W
R622	1-249-410-11	CARBON	270	5%	1/4W
R623	1-249-412-11	CARBON	390	5%	1/4W
△R701	1-212-863-00	FUSIBLE	18	5%	1/4W F
R702	1-247-752-11	CARBON	1K	5%	1/2W
R703	1-249-423-11	CARBON	3.3K	5%	1/4W
R704	1-249-421-11	CARBON	2.2K	5%	1/4W
R705	1-249-437-11	CARBON	47K	5%	1/4W
R706	1-249-425-11	CARBON	4.7K	5%	1/4W
R707	1-249-421-11	CARBON	2.2K	5%	1/4W
R708	1-249-421-11	CARBON	2.2K	5%	1/4W
R709	1-249-421-11	CARBON	2.2K	5%	1/4W
R710	1-249-427-11	CARBON	6.8K	5%	1/4W
R711	1-249-425-11	CARBON	4.7K	5%	1/4W
R712	1-249-421-11	CARBON	2.2K	5%	1/4W
R713	1-249-431-11	CARBON	15K	5%	1/4W
R714	1-249-429-11	CARBON	10K	5%	1/4W
R715	1-249-425-11	CARBON	4.7K	5%	1/4W
R716	1-249-437-11	CARBON	47K	5%	1/4W
R801	1-249-425-11	CARBON	4.7K	5%	1/4W
R802	1-249-417-11	CARBON	1K	5%	1/4W
R803	1-249-435-11	CARBON	33K	5%	1/4W
R804	1-249-437-11	CARBON	47K	5%	1/4W
R805	1-249-440-11	CARBON	82K	5%	1/4W
R806	1-249-413-11	CARBON	470	5%	1/4W

Ref. No.	Part No.	Description	Remark		
R807	1-247-903-00	CARBON	1M	5%	1/4W
R808	1-249-429-11	CARBON	10K	5%	1/4W
R810	1-249-437-11	CARBON	47K	5%	1/4W
R811	1-249-437-11	CARBON	47K	5%	1/4W
R812	1-249-421-11	CARBON	2.2K	5%	1/4W
R813	1-249-421-11	CARBON	2.2K	5%	1/4W
R814	1-249-429-11	CARBON	10K	5%	1/4W
R815	1-249-429-11	CARBON	10K	5%	1/4W
R816	1-249-429-11	CARBON	10K	5%	1/4W
R817	1-249-429-11	CARBON	10K	5%	1/4W
R818	1-249-429-11	CARBON	10K	5%	1/4W
R819	1-249-429-11	CARBON	10K	5%	1/4W
R820	1-249-436-11	CARBON	39K	5%	1/4W
R821	1-249-436-11	CARBON	39K	5%	1/4W
R822	1-249-437-11	CARBON	47K	5%	1/4W
R823	1-249-433-11	CARBON	22K	5%	1/4W
R824	1-249-426-11	CARBON	5.6K	5%	1/4W
R825	1-249-413-11	CARBON	470	5%	1/4W
R826	1-249-429-11	CARBON	10K	5%	1/4W
R827	1-249-429-11	CARBON	10K	5%	1/4W
R828	1-249-425-11	CARBON	4.7K	5%	1/4W
R829	1-249-425-11	CARBON	4.7K	5%	1/4W
△R830	1-212-954-11	FUSIBLE	6.8	5%	1/2W F
R831	1-249-427-11	CARBON	6.8K	5%	1/4W
R832	1-249-428-11	CARBON	8.2K	5%	1/4W
R833	1-249-428-11	CARBON	8.2K	5%	1/4W
R834	1-249-425-11	CARBON	4.7K	5%	1/4W
R835	1-249-425-11	CARBON	4.7K	5%	1/4W
△R836	1-212-954-11	FUSIBLE	6.8	5%	1/2W F
R837	1-249-429-11	CARBON	10K	5%	1/4W
R851	1-249-431-11	CARBON	15K	5%	1/4W
R852	1-249-437-11	CARBON	47K	5%	1/4W
R853	1-249-437-11	CARBON	47K	5%	1/4W
R854	1-249-429-11	CARBON	10K	5%	1/4W
R855	1-249-429-11	CARBON	10K	5%	1/4W
R856	1-249-437-11	CARBON	47K	5%	1/4W
R857	1-249-429-11	CARBON	10K	5%	1/4W
R859	1-249-437-11	CARBON	47K	5%	1/4W
R860	1-249-429-11	CARBON	10K	5%	1/4W
		< VARIABLE RESISTOR >			
RV801	1-241-629-11	RES, ADJ, CARBON	4.7K		
RV851	1-223-266-11	RES, VAR, CARBON	10K (CAL BIAS)		
		< SWITCH >			
S001	1-572-267-51	SWITCH, PUSH (AC POWER)	(1 KEY) (POWER)		
S601	1-554-303-21	SWITCH, TACTILE	(COUNTER MEMORY)		
S602	1-554-303-21	SWITCH, TACTILE	(COUNTER RESET)		
S603	1-554-303-21	SWITCH, TACTILE	(OPEN/CLOSE ☺)		

The components identified by mark △ or dotted line with mark △ are critical for safety. Replace only with part number specified.

SYSTEM CONTROL

Ref. No.	Part No.	Description	Remark
S604	1-554-303-21	SWITCH, TACTILE (■)	
S605	1-554-303-21	SWITCH, TACTILE (◀◀)	
S606	1-554-303-21	SWITCH, TACTILE (▶▶)	
S607	1-554-303-21	SWITCH, TACTILE (REC ●)	
S608	1-554-303-21	SWITCH, TACTILE (▶)	
S609	1-554-303-21	SWITCH, TACTILE (PAUSE ■■)	
S610	1-554-303-21	SWITCH, TACTILE (AMS ◀◀)	
S611	1-554-303-21	SWITCH, TACTILE (AMS ▶▶)	
S612	1-554-303-21	SWITCH, TACTILE (REC MUTE ○)	
S613	1-571-520-11	SWITCH, SLIDE (TIMER)	
S851	1-554-303-21	SWITCH, TACTILE (MONITOR)	
S852	1-692-368-11	SWITCH, ROTARY (DOLBY NR)	
S853	1-692-376-11	SWITCH, PUSH (1 KEY) (CALIBRATION)	
S854	1-692-376-11	SWITCH, PUSH (1 KEY) (MPX FILTER)	
< TRANSFORMER >			
△T901	1-423-685-11	TRANSFORMER, POWER	
< TEST PIN >			
* TP801	1-564-506-11	PLUG, CONNECTOR 3P	
< VIBRATOR >			
X601	1-577-358-21	VIBRATOR, CERAMIC (4MHz)	
X801	1-577-358-21	VIBRATOR, CERAMIC (4MHz)	

MISCELLANEOUS			

* 53	1-590-321-61	LEAD (WITH CONNECTOR)	
△57	1-575-651-21	CORD, POWER	
* 147	1-608-268-00	PC BOARD, ERASE HEAD	
158	1-632-779-11	PC BOARD, FG	
D1001	8-719-980-85	DIODE SLF-325C	
△F701	1-532-285-00	FUSE, TIME-LAG (T1.25AL/250V)	
HE501	1-543-836-11	HEAD, MAGNETIC (ERASE)	
HRP501	1-543-742-11	HEAD, MAGNETIC (REC/PB)	
M1001	X-3356-638-1	MOTOR (REEL R) ASSY	
M1002	X-3356-604-1	MOTOR (ASSIST) ASSY	
S1001	1-466-238-11	ENCODER, ROTARY	
△T901	1-423-685-11	TRANSFORMER, POWER	

Ref. No.	Part No.	Description	Remark
ACCESSORIES & PACKING MATERIALS			

	1-558-271-11	CORD, CONNECTION	
*	3-354-919-81	INDIVIDUAL CARTON	
*	3-366-547-01	CUSHION	
	3-704-366-01	SCREW (CASE) (M3X8)	
	3-756-186-11	MANUAL, INSTRUCTION (ENGLISH, FRENCH, SPANISH, PORTUGUESE) (AEP)	
	3-756-186-41	MANUAL, INSTRUCTION (GERMAN, DUTCH, SWEDISH, ITALIAN) (AEP)	
	3-756-186-51	MANUAL, INSTRUCTION (GERMAN) (German)	

***** HARDWARE LIST *****

#1	7-685-871-01	SCREW +BVTT 3X6 (S)
#2	7-682-547-09	SCREW +BV 3X6, S TIGHT
#3	7-685-133-19	SCREW +BTP 2.6X6 TYPE2 N-S
#4	7-682-147-15	SCREW, TR
#5	7-682-548-09	SCREW +BVTT 3X8 (S)
#6	7-621-849-00	SCREW (BV/RING)
#7	7-621-775-20	SCREW +B 2.6X5
#8	7-628-253-00	SCREW +PS 2X4
#9	7-621-255-20	SCREW +BVTT 2X4 (S)
#10	7-621-772-20	SCREW +B 2X5
#11	7-671-154-01	STENLESS BALL
#12	7-685-870-01	SCREW +BVTT 3X5 (S)
#13	7-621-772-70	SCREW +B 2X14
#14	7-622-205-05	NUT M2 TYPE2
#15	7-628-254-10	SCREW +PS 2.6X6
#16	7-682-648-09	SCREW +PS 3X8
#17	7-621-255-35	SCREW +BVTT 2X5 (S)
#18	7-682-548-04	SCREW +BVTT 3X8 (S)
#19	7-682-547-04	SCREW +B 3X6

The components identified by mark △ or dotted line with mark △ are critical for safety. Replace only with part number specified.