

# TC-K909ES

## SERVICE MANUAL

*US Model  
Canadian Model  
AEP Model  
E Model*



\* Dolby noise reduction and HX Pro headroom extension manufactured under license from Dolby Laboratories Licensing Corporation. HX Pro originated by Bang & Olufsen.

"DOLBY", the double-D symbol  and "HX PRO" are trademarks of Dolby Laboratories Licensing Corporation.

Model Name Using Similar Mechanism	TC-K222ESA/ TC-K890ES
Base Unit Name	TCM-200D11

### SPECIFICATIONS

Recording system	4-track 2-channel stereo
Fast winding time	Approx. 90 sec. (with Sony C-60 cassette)
Bias	AC bias
Heads	Erasing head × 1 (S&F head) Recording head × 1 (LA head) Playback head × 1 (LA head)
Motors	Capstan motor × 1 (direct-drive linear torque BSL motor) Reel motor × 1 (DC motor) Assist (mechanism drive) motor × 1 (DC motor)
Wow and flutter	±0.04% W.Peak (IEC) 0.022% W.RMS (NAB) ±0.065% W.Peak (DIN)

Harmonic distortion	0.4% (with Sony HF-S, 160nWb/m, 315Hz, 3rd H.D.) 1.3% (with Sony ES-IV, 250nWb/m, 315Hz, 3rd H.D.)
---------------------	---

#### Frequency response (Dolby NR off)

Type IV cassette (Sony ES-IV)	15 - 22,000 Hz (±3 dB, IEC) 15 - 16,000 Hz [±3 dB, (-4dB recording)]
Type II cassette (Sony UX-S or UX)	15 - 20,000 Hz (±3 dB, IEC)
Type I cassette (Sony HF-S)	15 - 17,000 Hz (±3 dB, IEC)

#### Signal-to-noise ratio (at peak level and weighted)

Cassette (Dolby NR off)	Type IV (Sony ES-IV)	Type II (Sony UX-S or UX)	Type I (Sony HF-S)
	61 dB	59 dB	57 dB

#### Inputs

Line inputs (phono jacks)	Sensitivity	0.16 V
	Input impedance	47 k ohms

—Continued next page—

S/N ratio improvement (approximate values)  
With Dolby B NR on: 5 dB at 1 kHz; 10 dB at 5 kHz  
With Dolby C NR on: 15 dB at 500 Hz; 20 dB at 1 kHz  
With Dolby S NR on: 10 dB at 100 Hz; 24 dB at 1 kHz



**STEREO CASSETTE DECK**  
**SONY®**

## Outputs

Line outputs (phono jacks)	Rated output level	0.5 V at a load impedance of 47 k ohms
	Load impedance	Over 10 k ohms
Headphones (stereo phone jack)	Output level	0 - 3 mW at a load impedance of 32 ohms

## General

Power requirements	120V AC, 60 Hz (US, Canadian model) 220—230V AC, 50/60Hz (AEP, German model) 120, 220 or 240V AC adjustable, 50/60 Hz (E model)
Power consumption	26W
Dimensions	Approx. 470 × 135 × 350 mm (w/h/d) (18 <sup>5</sup> / <sub>8</sub> × 5 <sup>3</sup> / <sub>8</sub> × 13 <sup>7</sup> / <sub>8</sub> inches) including projecting parts and controls
Mass	Approx. 8.2 kg (18 lbs 2 oz)

## Supplied accessories

Audio connecting cords (2)
M3×8 screws (4)
Remote commander RM-J701 (1) (E model)
Sony SUM-3 (NS) batteries (2) (E model)
AC plug adaptor (1) (E model)

Design and specifications are subject to change without notice.

## SAFETY CHECK-OUT

After correcting the original service problem, perform the following safety check before releasing the set to the customer:



Check the antenna terminals, metal trim, "metallized" knobs, screws, and all other exposed metal parts for AC leakage. Check leakage as described below.

## LEAKAGE TEST

The AC leakage from any exposed metal part to earth ground and from all exposed metal parts to any exposed metal part having a return to chassis, must not exceed 0.5 mA (500 microamperes). Leakage current can be measured by any one of three methods.

1. A commercial leakage tester, such as the Simpson 229 or RCA WT-540A. Follow the manufacturers' instructions to use these instruments.
2. A battery-operated AC milliammeter. The Data Precision 245 digital multimeter is suitable for this job.
3. Measuring the voltage drop across a resistor by means of a VOM or battery-operated AC voltmeter. The "limit" indication is 0.75 V, so analog meters must have an accurate low-voltage scale. The Simpson 250 and Sanwa SH-63Trd are examples of a passive VOM that is suitable. Nearly all battery operated digital multimeters that have a 2 V AC range are suitable. (See Fig. A)

### SAFETY-RELATED COMPONENT WARNING!!

COMPONENTS IDENTIFIED BY MARK  OR DOTTED LINE WITH MARK  ON THE SCHEMATIC DIAGRAMS AND IN THE PARTS LIST ARE CRITICAL TO SAFE OPERATION. REPLACE THESE COMPONENTS WITH SONY PARTS WHOSE PART NUMBERS APPEAR AS SHOWN IN THIS MANUAL OR IN SUPPLEMENTS PUBLISHED BY SONY.

### ATTENTION AU COMPOSANT AYANT RAPPORT À LA SÉCURITÉ!

LES COMPOSANTS IDENTIFIÉS PAR UNE MARQUE  SUR LES DIAGRAMMES SCHÉMATIQUES ET LA LISTE DES PIÈCES SONT CRITIQUES POUR LA SÉCURITÉ DE FONCTIONNEMENT. NE REMPLACER CES COMPOSANTS QUE PAR DES PIÈCES SONY DONT LES NUMÉROS SONT DONNÉS DANS CE MANUEL OU DANS LES SUPPLÉMENTS PUBLIÉS PAR SONY.

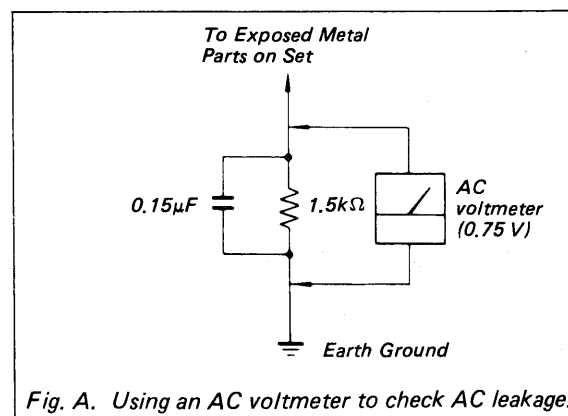
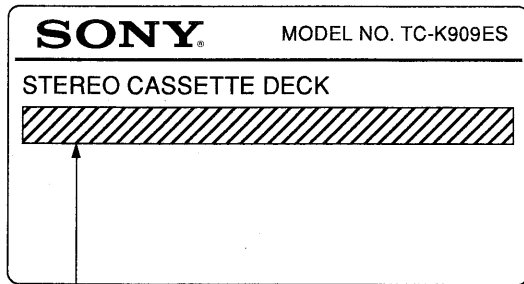

Fig. A. Using an AC voltmeter to check AC leakage.

## MODEL IDENTIFICATION



US, Canadian model : AC 120V 60Hz 26W  
 AEP, German model : AC 220—230V~50/60Hz 26W  
 E model : AC 120, 220, 240V~50/60Hz 26W

## TABLE OF CONTENTS

<u>Section</u>	<u>Title</u>	<u>Page</u>
<b>1. GENERAL</b>	.....	4
<b>2. DISASSEMBLY</b>		
	Cassette Holder .....	5
	Ornamental Plate .....	5
	Pinch Lever/Lever (FR2) .....	5
	Comparator Board/Capstan Board/Flywheel/FG Board .....	6
	MD Board .....	6
	Reel Motor Board .....	6
<b>3. MECHANICAL ADJUSTMENTS</b>	.....	7
<b>4. ELECTRICAL ADJUSTMENTS</b>	.....	10
<b>5. DIAGRAMS</b>		
	• IC Pin Assignment .....	15
	5-1. Block Diagram .....	19
	5-2. Printed Wiring Boards — Audio Section — .....	23
	5-3. Schematic Diagram — Audio Section — .....	27
	5-4. Schematic Diagram — System Control Section — .....	31
	5-5. Printed Wiring Boards — System Control Section — .....	35
	5-6. Semiconductor Lead Layouts .....	37
	5-7. Circuit Boards Location .....	37
	5-8. Schematic Diagram — DOLBY S Section — .....	40
<b>6. EXPLODED VIEWS</b>		
	6-1. Panel Section .....	42
	6-2. Chassis Section .....	43
	6-3. Mechanism Section-1 .....	44
	6-4. Mechanism Section-2 .....	45
<b>7. ELECTRICAL PARTS LIST</b>	.....	46

# SECTION 1 GENERAL

## Identifying the Parts

### Front Panel

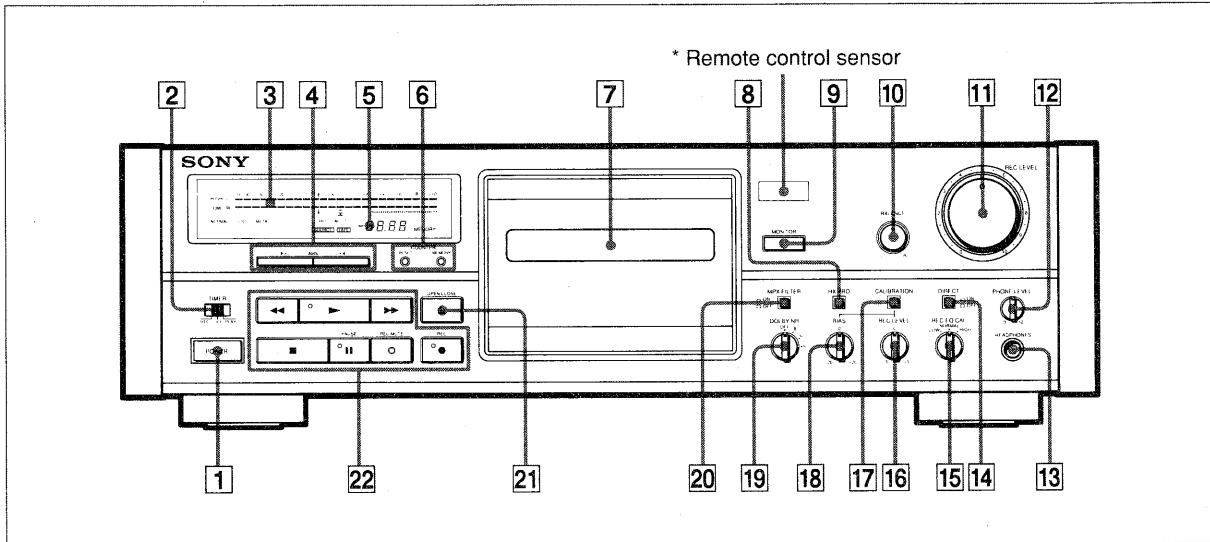



For details, refer to the page number(s) indicated in parentheses.

- 1 POWER switch
- 2 TIMER switch
- 3 Peak program meter
- 4 AMS (Automatic Music Sensor) buttons
- 5 Linear counter
- 6 COUNTER buttons  
RESET button  
MEMORY button
- 7 Cassette holder
- 8 HX PRO button
- 9 MONITOR button
- 10 BALANCE control
- 11 REC (recording) LEVEL control
- 12 PHONE (headphones) LEVEL control
- 13 HEADPHONES jack (stereo phone jack)
- 14 DIRECT button
- 15 REC EQ CAL (recording equalizing calibration) switch (LOW, NORMAL, HIGH)
- 16 REC (recording) LEVEL control for calibration
- 17 CALIBRATION button
- 18 BIAS control
- 19 DOLBY NR (noise reduction) switch

- 20 MPX FILTER button
- 21 OPEN/CLOSE button
- 22 Tape operation buttons and indicators  
◀◀ (rewind) button  
▶▶ (play) button and indicator  
▶▶ (fast-forward) button  
■ (stop) button  
|| PAUSE button and indicator  
○ REC MUTE (record muting) button  
● REC (recording) button and indicator

#### \* Remote control sensor

- You can remotely control this cassette deck with:
- A remote commander that came with a Sony amplifier or receiver if it has the  mark and cassette deck control capability.
  - An optional Sony remote commander with the  mark and cassette deck control capability.

## SECTION 2 DISASSEMBLY

NOTE: Follow the disassembly procedure in the numerical order given.

### CASSETTE HOLDER

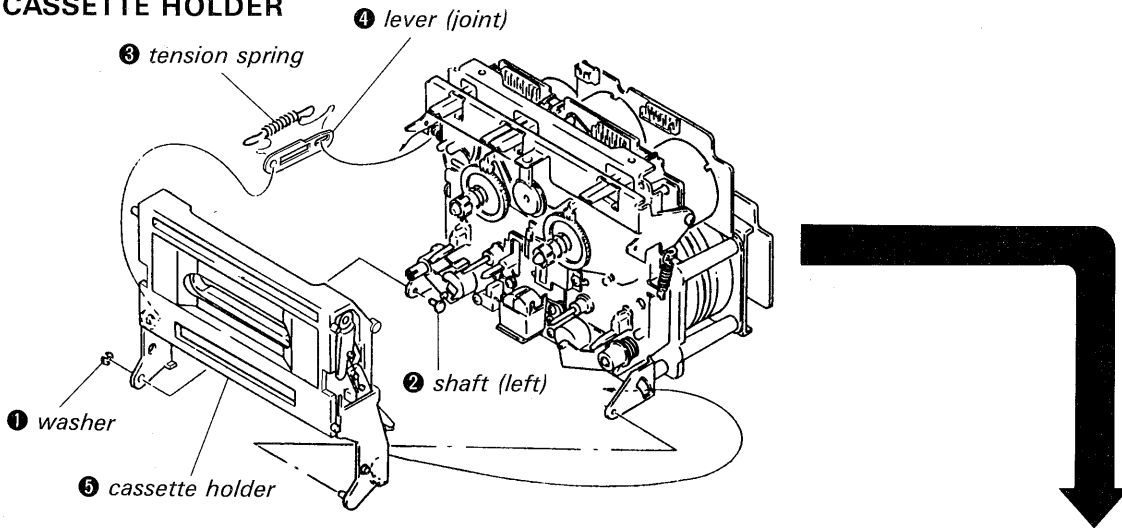

### ORNAMENTAL PLATE

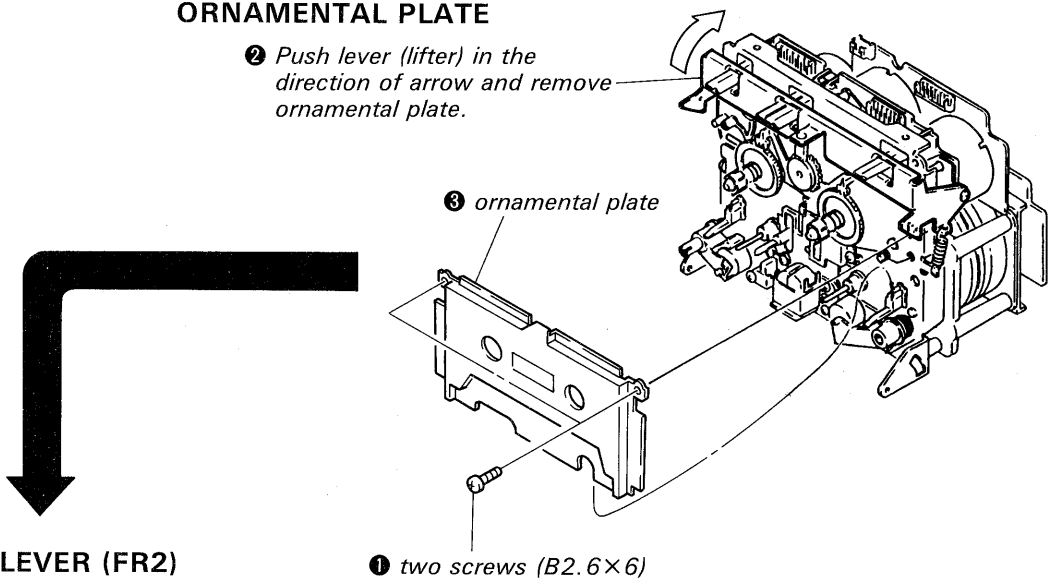

### PINCH LEVER/LEVER (FR2)

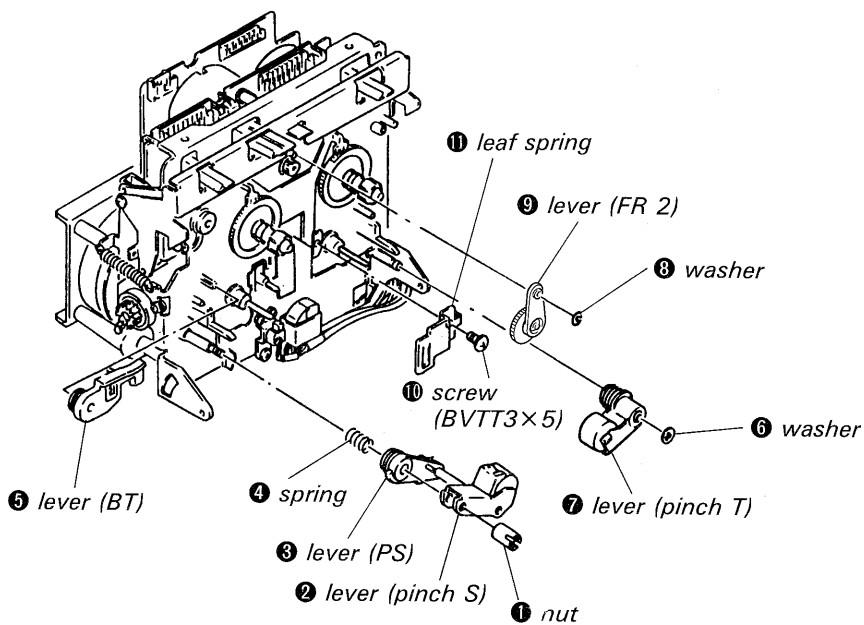

## COMPARATOR BOARD/CAPSTAN BOARD/FLYWHEEL/FG BOARD

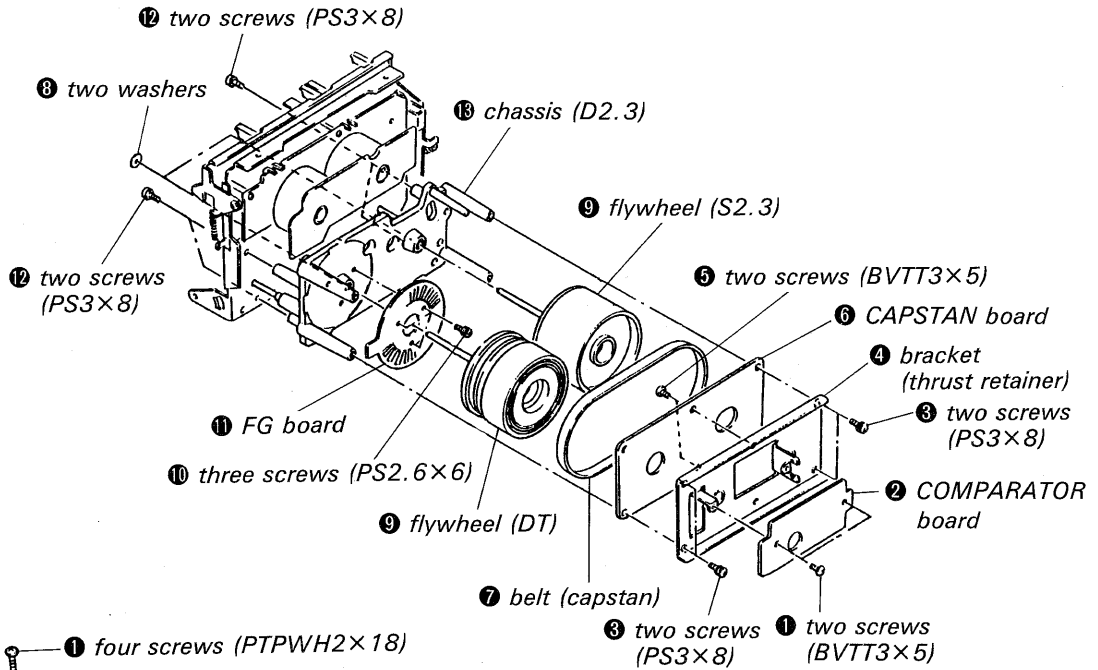

## MD BOARD

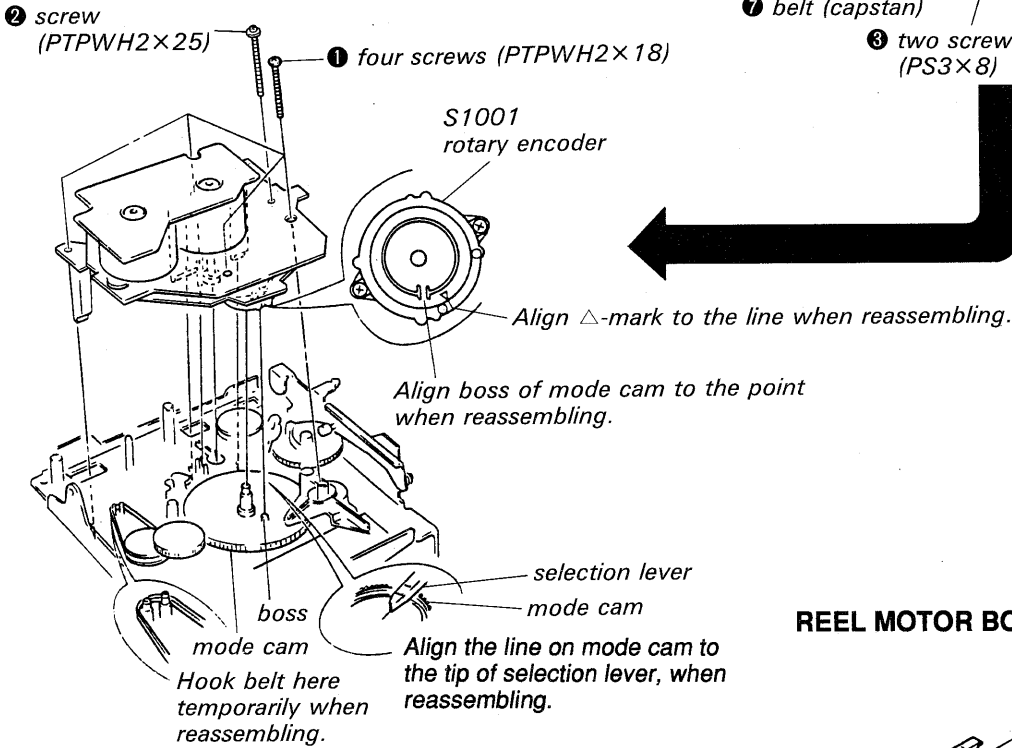

## REEL MOTOR BOARD

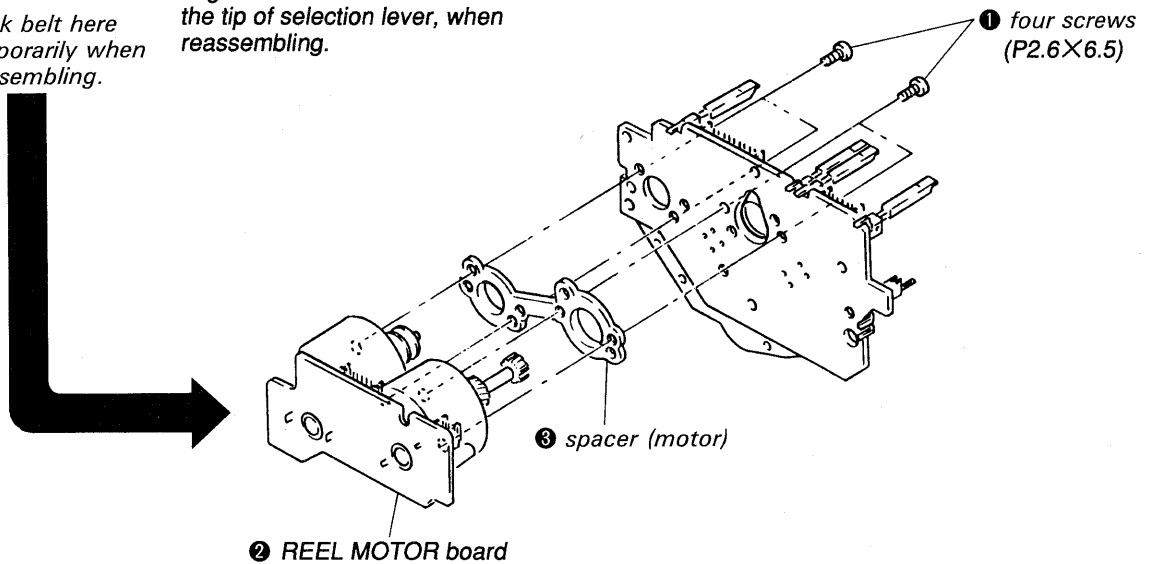

## SECTION 3 MECHANICAL ADJUSTMENTS

• Refer to page 9 for Adjustment Location.

### PRECAUTIONS

1. Clean the following parts with an alcohol-moistened swab.  
(tape sliding surface)
2. Demagnetize the record/playback heads, erase heads and the capstan using the head demagnetizer.
3. Do not use a magnetized screw driver for the adjustments.
4. After the adjustments, apply suitable locking compound to the parts adjusted.
5. The adjustment should be performed with the rated power supply voltage unless otherwise noted.

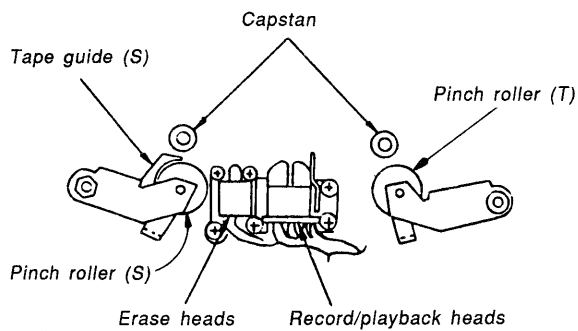

## Tape Passing Adjustment

**Note:** For the following adjustments, use the jig as far as possible. Although the following methods are operable without using the jig, precise adjustment may not be completed, for example no compatibility to other decks is available even if self recording and playback is OK.

In these adjustments, either the pinch roller guide in the S side or the record/playback head guide is referred to for tape pass. Therefore, do not unnecessarily rotate the adjustment screws including those of the erase heads unless any one is replaced. When 2 or more heads or pinch rollers out of these 2 heads and pinch rollers are to be adjusted or replaced, use the jig for the adjustments or replace one at first and then take complete tape pass and then replace the second one.

Head height adjusting jig : apex

### Preparation:

- Mirror cassette CQ009C 8-909-708-01  
(Or CQ012C 8-909-708-02)

If it is not available, cut a part of the half of a 120 minute cassette tape and use.

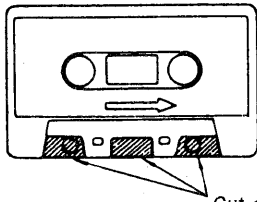

- Plus screw driver  
Medium size .....Apply to the head adjusting screw.
- Minus screw driver  
Large size .....Apply to the pinch roller adjusting screw in the S side.
- Pen light
- WS-48B (3kHz, 0dB)
- P-4-A100 (10kHz, -10dB)

### Definition:

The following view relates to record/playback heads.

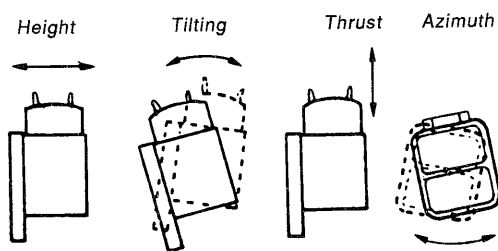

For the locations of the adjusting screws, see the view "adjustment location" in the lower right corner of Page 10.

### Procedure:

#### Pinch roller in the S side

**Note:** It should be adjusted only when the pinch roller in the S side is replaced.

1. Mount the mirror cassette and set the equipment to playback state.
2. Check that the tape is curled in the pinch roller guide or the guide of the record/playback heads.

If curled, remedy it by rotating the tape curl adjusting screw **H**. At the time, check that the tape runs near the center part of the erase heads.

## Record/playback heads

**Note:** The heads should be adjusted only when the record/playback head is replaced.

1. Mount the mirror cassette and set the equipment to playback state.
2. (Height adjustment) Check that the tape is curled in the tape guide of the heads. If curled, rotate screws **A**, **B** and **C** in the same angle and move the entire heads parallel. Check the mirror cassette where there is curling and, when curling exists in the lower side (actually in the deep side), tighten all screws slightly. If curled in the upper (your) side, loosen them.

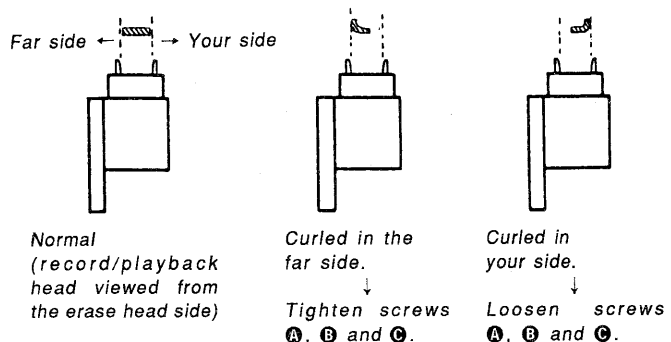

3. (Adjustment of tilting) Adjust back tension to 0 still in playback state (loosen the tape by rotating the reel in the S side using a small tip such as a pencil), and check that there is no curling or snaking (up or down) in the guide of the record/playback heads. Snaking of the tape may occur only within the range of a difference in the widths of the tape and the tape guide (it curls when tape slacks more than the range). Therefore, carefully check it because it may often be overlooked.
- If the tape is snaking, rotate screws **B** and **C** in the same angle and change the tilting of the heads. Tighten or loosen the screws to remedy up or down snaking, respectively.
4. Repeat the adjustment 2 and 3 again and converge the height and tilting to suitable positions.
  5. (Tentative adjustments of azimuth) Demagnetize and clean the heads and playback WS48B (3kHz, 0dB). Rotate the screw **C** so that the pointer of the level meter of the set or connected to LINE OUT becomes maximum. If the screw is rotated more than 1/2 turn, repeat the adjustments again from 1.
  6. (Checking of tape pass) Connect an oscilloscope to LINE OUT, replay P-4-A100 (10kHz, -10dB) to describe Lissajou's figures. At about 20 seconds after beginning playback (the tension in the loop becomes stable), check that the variation of the Lissajou's figures occur within  $\pm 90^\circ$  (more preferably within  $\pm 45^\circ$ ). If beyond  $\pm 90^\circ$ , adjustments of tilting or height will not be complete, so finely adjust the equipment again from 1.



Standard adjustment tape  
P-4-A100  
(10kHz, -10dB)

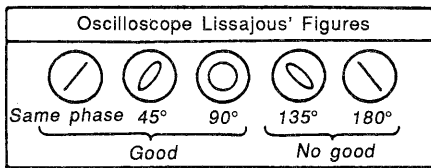
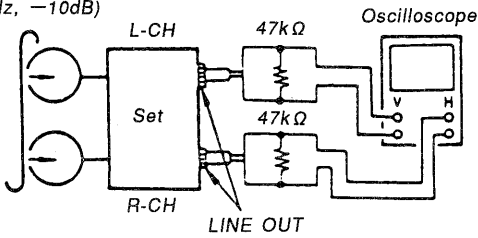

**Erase heads**

**Note:** The heads should be adjusted only when the erase head is replaced.

1. Mount the mirror cassette and set the equipment to playback state.
2. (Azimuth adjustments) Adjust screws **E** or **F** so that the tape runs as parallel to the erase heads as possible.

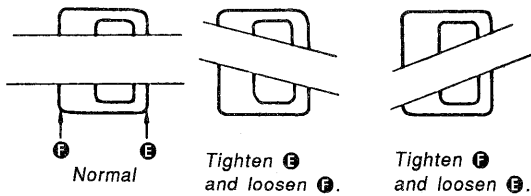

(Erase head viewed in the mirror cassette)

3. (Height adjustment) Rotate screws **D**, **E** and **F** in the same angle so that the widths of erase heads seen in the upper and lower sides of the tape become essentially the same. If the width in the upper or lower side is larger, tighten or loosen the screws, respectively.

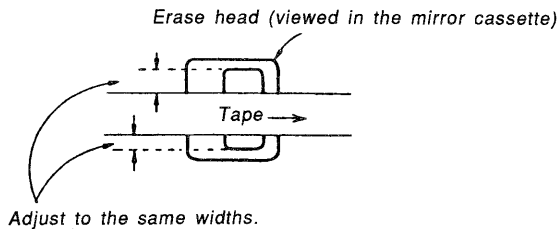

4. (Adjustments of tilting) Adjust back tension to 0 still in playback state and check that there is no snaking in the erase heads and pinch roller guide in the S side. If there is, change tilting by rotating the screw **D**. When the tape moves up or down in the mirror tape, tighten or loosen the screw, respectively.

5. Repeat the adjustments again from 2. and converge the height and tilting to more suitable values. And, check that there are no tape curls in the pinch roller guide and the guide of the record/playback heads.
6. (Adjustments of thrust) Slightly loosen the screw **G** and finely adjust it so that the tape smoothly runs over the entire surfaces of the heads by adjusting the thrust of the erase heads to an optimum value relative to the tape.

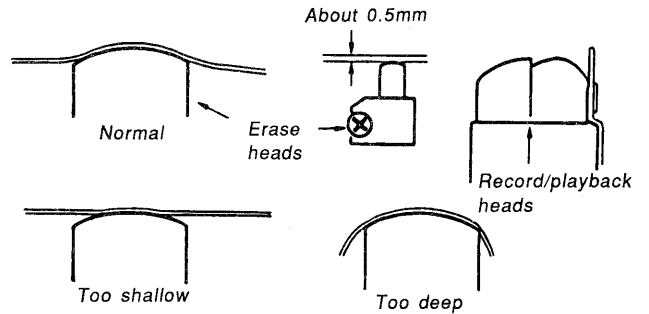

**Checking**

1. Check that the tape smoothly runs over the entire tape pass without curling or snaking.
2. After the adjustments, apply the locking compound to the screws adjusted (apply the compound to the screw **C** only after the final azimuth adjustments are completed).

**Adjustment Location:**

The following views relate to those in the mirror cassette (upper) and MD viewed from your side (lower).

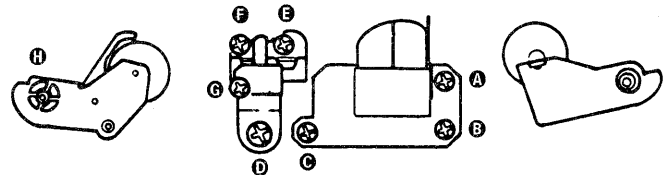
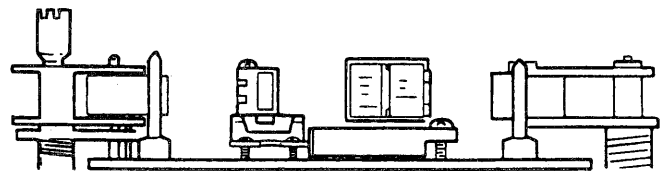

Pinch roller in the S side

Erase heads Record/playback heads

Pinch roller in the T side

# SECTION 4 ELECTRICAL ADJUSTMENTS

0dB=0.775V

1. Perform adjustment in the order listed below. (As a rule, adjust the record system after adjustment of playback system has been completed.)
2. Adjust and measure both channels unless otherwise specified.
3. To perform simultaneous record and playback, select recording mode, and set MONITOR switch to TAPE, then play back immediately the recorded signal to take out from LINE OUT.

• Switch position

DOLBY NR .....OFF  
 MPX FILTER .....OFF  
 TIMER .....OFF  
 MONITOR .....TAPE  
 HX PRO .....OFF  
 CALIBRATION .....OFF  
 DIRECT .....OFF  
 BIAS .....CENTER CLICK  
 REC LEVEL .....CENTER CLICK  
 BALANCE .....CENTER CLICK

• Standard Record

Adjust the REC LEVEL (RV502) and BALANCE (RV501) controls so that the I/O signal levels specified below can be attained.

Record Mode

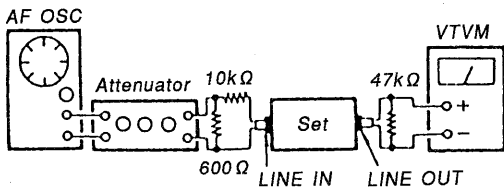

Standard Input Level

Input pin	LINE IN
Signal source impedance	10kΩ
Input signal level	0.25V (-10dB)

Standard Output Level

Output pin	LINE OUT
Load impedance	47kΩ
Output signal level	0.32V (-7.7dB)

Test tape

Type	Signal	Used for
WS-48B	3kHz, 0dB	Tape speed/WOW check
P-4-A100	10kHz, -10dB	Azimuth adjustment
P-4-L300	315Hz, 0dB	PB level adjustment

Torque Adjustment

1. Load the torque measuring tape CQ-102C, and play back. Adjust RV801 so that the torque meter reading is  $40 \pm 5g \cdot cm$ . ( $0.556 \pm 0.069$  oz·inch)
2. After adjustment, measure back tension and FF/REW torque, and make sure that measured data satisfies the specification.

Torque	Torque meter	Meter reading
FWD	CA-102C	35-45g·cm (0.49-0.62 oz·inch)
FWD back tension	CA-102C	7-11g·cm (0.10-0.15 oz·inch)
FF/REW	CQ-201B	65-90g·cm (0.91-1.25 oz·inch)

Tape Speed/WOW Check

Procedure:

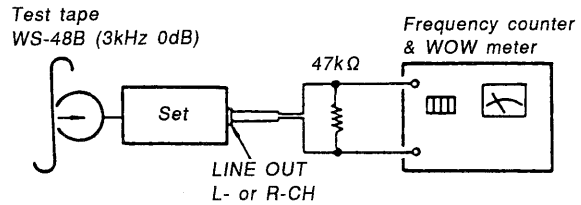

1. Play back the top of test tape to measure its output frequency and WOW value.
2. Invert test tape and perform same measurement, then check for difference between top and end of tape.

Specification:

Tape speed deviation : within 2,990~3,010Hz  
 Tape speed fluctuation : within 2,990~3,010Hz  
 WOW (WRMS) : 0.047% or less

MPX Filter Check

Condition:

DOLBY NR switch : OFF  
 MPX FILTER switch : OFF

Procedure:

1. Mode : stop

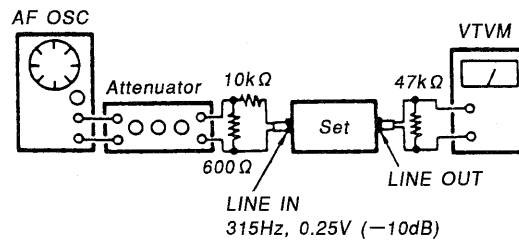

2. Applying 315Hz, 0.25V (-10dB) signal, adjust the REC LEVEL and BALANCE controls so that the LINE OUT level is 0.32V (-7.7dB).
3. Applying 19kHz, 0.25V (-10dB) signal, measure the LINE OUT level.

Specification:

DOLBY NR switch: Either B, C or S  
 MPX FILTER switch: ON, LINE OUT level must be,  
 315Hz: within 0.28~0.36V (within -8.7~-6.7dB)  
 19kHz: 9.8mV (-38dB) or less

### Record/Playback Head Azimuth Adjustment

Procedure:

1. Mode : FWD playback

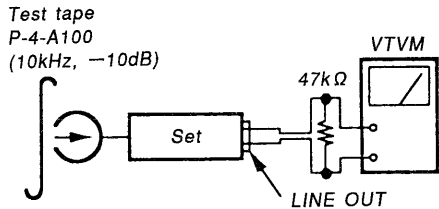

2. Turn the adjustment screw for the maximum output levels. If these levels do not match, turn the adjustment screw until both of output levels match together within 1dB.

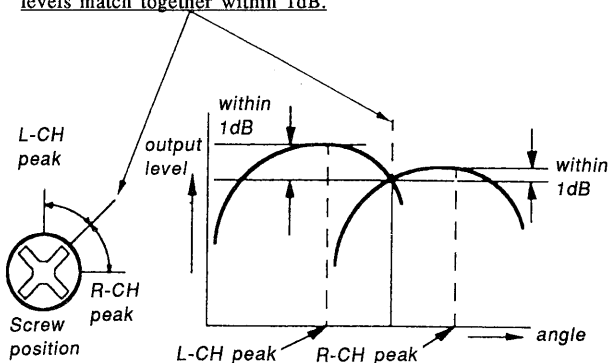

3. Phase Check  
Mode: playback

Test tape  
P-4-A100  
(10kHz, -10dB)

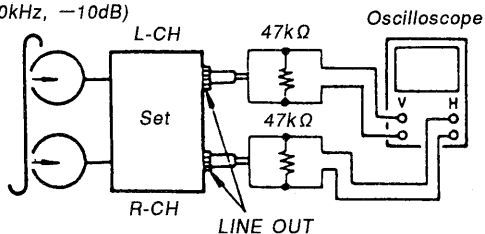

4. Confirm that the phase difference between L-CH and R-CH is in-phase to 90°.

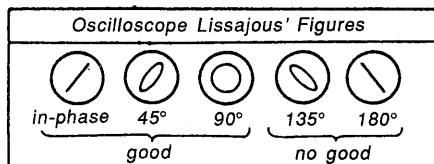

Adjustment Location:

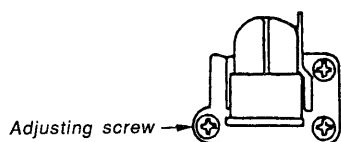

### Playback Level Adjustment

Procedure:

1. Mode: playback

Test tape  
P-4-L300  
(315Hz, 0dB)

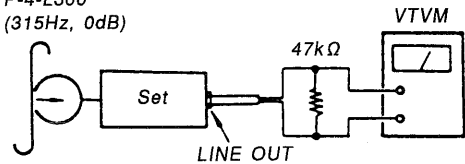

2. Adjust the RV101 (L-CH) and RV201 (R-CH) to satisfy the following specification.

Adjustment Value:

LINE OUT level : 302 — 338mV  
(-8.2 — -7.2dB)

Level difference between channels: within 0.5dB

Confirm that the LINE OUT level does not change when playback and stop are repeated.

### Erase Current Adjustment

Procedure:

1. Mode: record

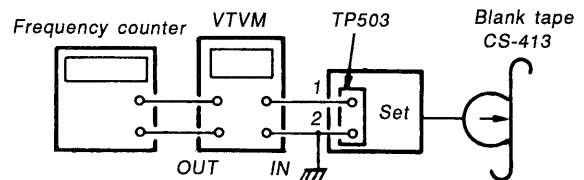

2. Adjust RV506 so that VTVM reading is 110mV (erase current 110mA).
3. At this time, confirm oscillation frequency.

Adjustment Value:

Erase current: 110 ±<sub>5</sub><sup>0</sup> mA

Oscillation frequency: 160 ± 6kHz

### Bias Consumption Current Adjustment

**Note:** The bias consumption current must be adjusted before adjusting the record bias. Retry record bias adjustment after the bias consumption current is adjusted.

Condition:

HX PRO switch: ON

Procedure:

1. Set semi-fixed resistors RV104 (L-CH), RV204 (R-CH) and RV505 for record bias adjustment to mechanical center, and select the recording mode without applying a signal.
2. Adjust T101 (L-CH) and T201 (R-CH) so that the digital voltmeter reading becomes minimum.

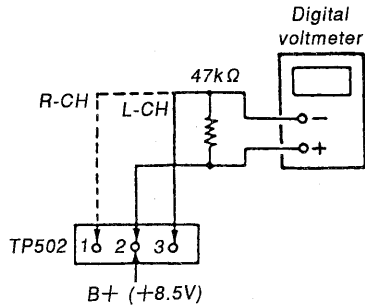

Specification: 120mV or less  
(This value is measured using CS-413 after bias adjustment.)

### Bias and Recording level adjustment (HX PRO: ON)

Condition:

REC LEVEL control: Specified recording position (Page 10)

HX PRO switch: ON

Procedure:

1. Mode: simultaneous record and playback

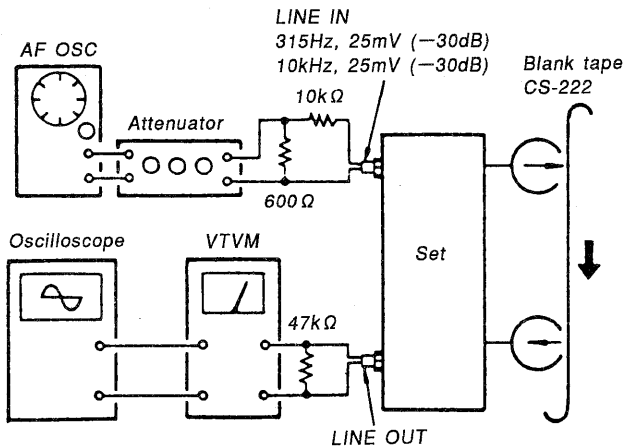

2. Adjust the following controls so that the minimum output becomes the specified output level.

- (1) RV104 (L-CH) and RV204 (R-CH) ..... Bias adjustment
- (2) RV103 (L-CH) and RV203 (R-CH) ..... Recording level adjustment

Adjustment Value:

- (1) Level of 10kHz against 315Hz:  $0 \pm 0.3\text{dB}$
- (2) 315Hz level:  $30.9 - 33.1\text{mV} (-28.0 - -27.4\text{dB})$

### Bias Adjustment (HX PRO: OFF)

Condition:

REC LEVEL control: Specified recording position (page 10)

HX PRO switch: OFF

Procedure:

1. Mode: simultaneous record and playback

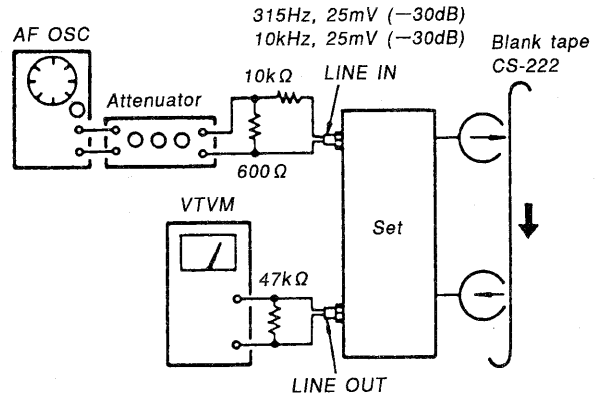

2. Adjust RV105 (L-CH) and RV205 (R-CH) so that 10kHz playback output is  $0 \pm 0.3\text{dB}$  relative to the 315Hz output.

### Metal Bias Adjustment

Condition:

REC LEVEL control: Specified recording position (page 10)

HX PRO switch: OFF

Procedure:

1. Mode: simultaneous record and playback

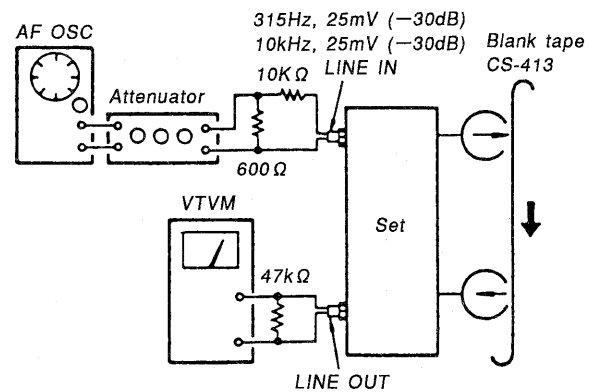

2. Adjust RV505 so that 10kHz R-CH output is  $0 \pm 0.3\text{dB}$  relative to the 315Hz output.

### Calibration Adjustment and Level Meter Adjustment

Condition:

CALIBRATION switch: ON

Procedure (oscillation output level adjustment):

1. Mode: record (No signal to LINE IN)

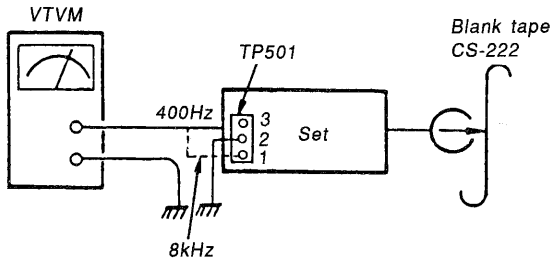

2. Adjust RV508 so that the 400Hz check point level is 2.32 — 2.59V (9.5dB—10.5dB).
3. Adjust RV507 so that the 8kHz check point level is 2.32 — 2.59V (9.5dB—10.5dB).

Procedure (level meter adjustment):

1. Record mode (No signal to LINE IN)
2. Adjust RV202 to higher side, then lower it gradually. Adjust so that the level "a" higher by one point than 0dB of LOW FREQ segment (lower) of CAL level meter turns off.
3. Adjust RV102 so that HIGH FREQ segment (upper) up to 0dB position of CAL level meter turns on.

HIGH: Blinking of level "a" higher by 1 point is acceptable.

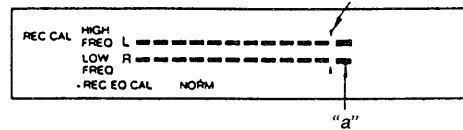

LOW: Blinking of level "a" higher by 1 point is not acceptable.

### AUDIO (A) BOARD (component side)

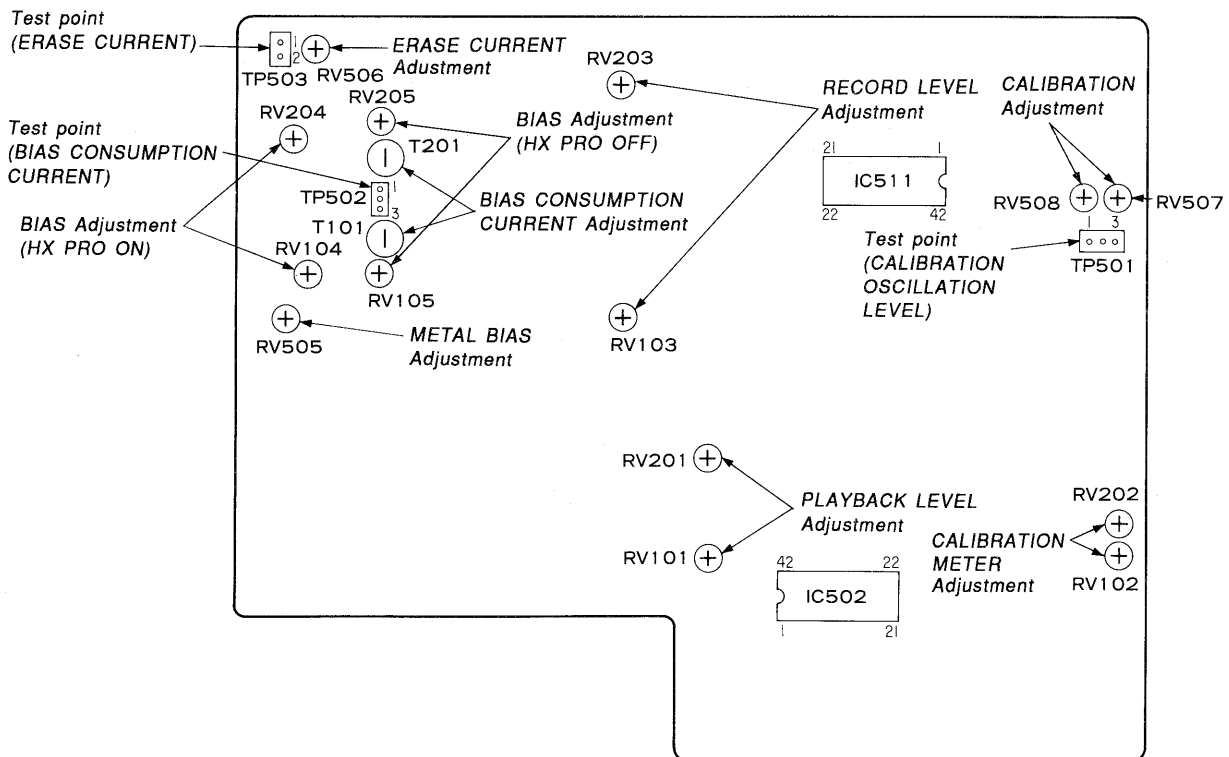

**SYSTEM CONTROL (A) BOARD (component side)**

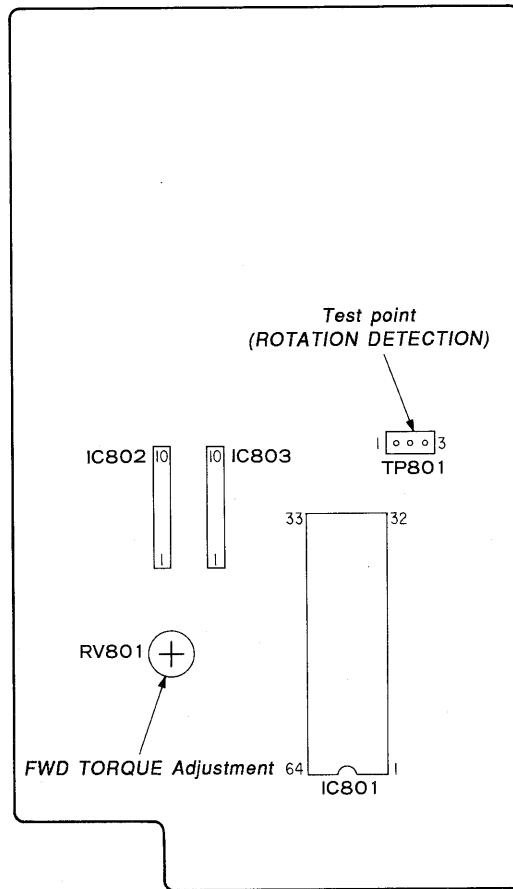

## SECTION 5 DIAGRAMS

### IC PIN ASSIGNMENT

#### IC801 Master Microcomputer (M50964-226SP)

This IC controls, based on input signals from various switches and remote devices, the mechanical deck, audio signal switching for equalizer, muting, etc. and data transfer to the display microcomputer.

Pin. No.	Pin Name	I/O	Function																																													
1	Vcc	—	Power supply (+5V)																																													
2	AVss	—	Power supply (GND)																																													
3	Vref	I	Reference voltage input (+5V) to A/D ports																																													
4	DATA	O	Data output (analog) to display microcomputer (IC601)																																													
5	PWM	—	Not used																																													
6	ADR0	O	Data output to display microcomputer (IC601)																																													
7	$\overline{\text{REC}}$	O	Not used (Connected to GND)																																													
8	$\overline{\text{PAUSE}}$	O	Not used (Connected to GND)																																													
9	$\overline{\text{PLAY}}$	O	Not used (Connected to GND)																																													
10	AD7	I	Key switch input (analog) 0V: "▲", 1V: "■", 2V: "◀", 3V: "▶", 4V: "●"																																													
11	AD6	I	Key switch input (analog) 0V: "▶", 1V: "  ", 2V: "◀◀", 3V: "▶▶", 4V: "○"																																													
12	AD5	I	Key switch input (analog) 0V: "RESET", 1V: "MEMORY", 2V: "DISPLAY MODE"																																													
13	TIMER SW	I	Key switch input (analog) 3V: "REC", 4V: "PLAY", 5V: "OFF"																																													
14	T-PULSE	I	Mechanism deck take-up reel table sensor pulse input																																													
15	S-PULSE	I	Mechanism deck supply reel table sensor pulse input																																													
16	COUNT 0	I	Negative pulse input at counter 0																																													
17	—	—	Not used																																													
18	RSTOUT	O	Not used (Connected to GND)																																													
19	S-CLOCK	O	Not used (Connected to GND)																																													
20	S-OUT	O	Not used (Connected to GND)																																													
21	S-IN	I	Not used (Pull up)																																													
22	SIRCS-L	I	SIRCS signal (remote control) normal phase input																																													
23	$\overline{\text{SIRCS-E}}$	I	SIRCS signal (remote control) inverted phase input Inverted SIRCS-L input																																													
24	POW-OUT	O	Not used (Open)																																													
25	POWER IN	I	Power down detection input																																													
26	$\overline{\text{INT1}}$	I	Power down detection input																																													
27	CNVss	—	Power supply (GND)																																													
28	$\overline{\text{RESET}}$	I	RESET input																																													
29	XIN	I	Clock input (4MHz)																																													
30	XOUT	O	Clock output (4MHz)																																													
31	$\phi$	—	Not used																																													
32	Vss	—	Power supply (GND)																																													
33~36	$\overline{\text{PAT3}} \sim \overline{\text{PAT0}}$	I	Rotary encoder input for mechanism deck head base position detection <table border="1" style="margin-left: auto; margin-right: auto;"> <thead> <tr> <th></th> <th>PAUSE</th> <th>AMS</th> <th>FF/REW</th> <th>STOP</th> <th colspan="2">PLAY</th> <th colspan="2">EJECT</th> </tr> </thead> <tbody> <tr> <td><math>\overline{\text{PAT3}}</math></td> <td>L</td> <td>L</td> <td>L</td> <td>L</td> <td>H</td> <td>H</td> <td>H</td> <td>H</td> </tr> <tr> <td><math>\overline{\text{PAT2}}</math></td> <td>L</td> <td>L</td> <td>H</td> <td>H</td> <td>L</td> <td>L</td> <td>H</td> <td>H</td> </tr> <tr> <td><math>\overline{\text{PAT1}}</math></td> <td>L</td> <td>H</td> <td>L</td> <td>H</td> <td>L</td> <td>H</td> <td>L</td> <td>H</td> </tr> <tr> <td><math>\overline{\text{PAT0}}</math></td> <td>L</td> <td>H</td> <td>H</td> <td>L</td> <td>L</td> <td>L</td> <td>L</td> <td>L</td> </tr> </tbody> </table>		PAUSE	AMS	FF/REW	STOP	PLAY		EJECT		$\overline{\text{PAT3}}$	L	L	L	L	H	H	H	H	$\overline{\text{PAT2}}$	L	L	H	H	L	L	H	H	$\overline{\text{PAT1}}$	L	H	L	H	L	H	L	H	$\overline{\text{PAT0}}$	L	H	H	L	L	L	L	L
	PAUSE	AMS	FF/REW	STOP	PLAY		EJECT																																									
$\overline{\text{PAT3}}$	L	L	L	L	H	H	H	H																																								
$\overline{\text{PAT2}}$	L	L	H	H	L	L	H	H																																								
$\overline{\text{PAT1}}$	L	H	L	H	L	H	L	H																																								
$\overline{\text{PAT0}}$	L	H	H	L	L	L	L	L																																								
37	$\overline{\text{OPEN SW}}$	I	Mechanism deck OPEN SW (S1004) input "L": Cassette holder is opened																																													
38	$\overline{\text{CLOSE SW}}$	I	Mechanism deck CLOSE SW (S1003) input "L": Cassette holder is closed																																													

Pin. No.	Pin Name	I/O	Function															
39	$\overline{\text{DOOR SW}}$	I	Mechanism deck DOOR SW (S1002) input "L": Cassette holder status changes from open to close															
40	$\overline{\text{REC SW}}$	I	Mechanism deck REC SW (S1001) input "L": REC protector is broken															
41	$70\mu\text{ SW}$	I	Mechanism deck $70\mu\text{ SW}$ (S1008) input "H": $70\mu\text{ S}$ , "L": $120\mu\text{ S}$ (constant when playback EQ)															
42	$\overline{\text{HALF SW}}$	I	Mechanism deck HALF SW (S1006) input "L": Tape is loaded															
43	$\overline{\text{METAL SW}}$	I	Mechanism deck METAL SW (S1007) input "H": Metal tape, "L": Normal or CrO <sub>2</sub> tape															
44	—	—	Not used															
45	$\overline{\text{CAM UP}}$	O	Mechanism deck head base UP output															
46	$\overline{\text{CAM DOWN}}$	O	Mechanism deck head base DOWN output <table border="1" style="margin-left: 20px;"> <thead> <tr> <th></th> <th>STOP</th> <th>DOWN</th> <th>UP</th> <th>STOP</th> </tr> </thead> <tbody> <tr> <td><math>\overline{\text{CAM UP}}</math></td> <td>L</td> <td>H</td> <td>L</td> <td>H</td> </tr> <tr> <td><math>\overline{\text{CAM DOWN}}</math></td> <td>L</td> <td>L</td> <td>H</td> <td>H</td> </tr> </tbody> </table>		STOP	DOWN	UP	STOP	$\overline{\text{CAM UP}}$	L	H	L	H	$\overline{\text{CAM DOWN}}$	L	L	H	H
	STOP	DOWN	UP	STOP														
$\overline{\text{CAM UP}}$	L	H	L	H														
$\overline{\text{CAM DOWN}}$	L	L	H	H														
47	$\overline{\text{M-FWD}}$	O	Reel motor forward run															
48	$\overline{\text{M-REV}}$	O	Reel motor reverse run <table border="1" style="margin-left: 20px;"> <thead> <tr> <th></th> <th>STOP</th> <th>FWD/ CLOSE</th> <th>REV/ OPEN</th> <th>BRAKE</th> </tr> </thead> <tbody> <tr> <td><math>\overline{\text{M-FWD}}</math></td> <td>L</td> <td>L</td> <td>H</td> <td>H</td> </tr> <tr> <td><math>\overline{\text{M-REV}}</math></td> <td>L</td> <td>H</td> <td>L</td> <td>H</td> </tr> </tbody> </table>		STOP	FWD/ CLOSE	REV/ OPEN	BRAKE	$\overline{\text{M-FWD}}$	L	L	H	H	$\overline{\text{M-REV}}$	L	H	L	H
	STOP	FWD/ CLOSE	REV/ OPEN	BRAKE														
$\overline{\text{M-FWD}}$	L	L	H	H														
$\overline{\text{M-REV}}$	L	H	L	H														
49	$\overline{\text{M-PLAY}}$	O	"L" when reel motor runs at PLAY speed															
50	$\overline{\text{M-FAST}}$	O	"L" when reel motor runs at FF/REW speed															
51	$\overline{\text{BIAS}}$	O	Bias oscillation control output "L": Oscillation, "H": OFF															
52	$\overline{\text{REC MUTE}}$	O	REC mute control output "H": Mute															
53	$\overline{\text{MONITER}}$	O	Monitor switch output "H": TAPE, "L": SOURCE															
54	$\overline{\text{LINE MUTE}}$	O	Line mute control output "H": Mute															
55	—	—	Not used (Connected to AMS MODE)															
56	$\overline{\text{AMS MODE}}$	O	AMS switch output "L": AMS															
57	$\overline{\text{TYPE I}}$	O	REC equalizer switching output "L": Normal tape															
58	$\overline{\text{TYPE II}}$	O	REC equalizer switching output "L": CrO <sub>2</sub> tape															
59	$\overline{\text{TYPE IV}}$	O	REC equalizer switching output "L": Metal tape															
60	$\overline{\text{AMS SIG}}$	I	AMS signal input "L": No music "H": Music															
61	$\overline{\text{SOURCE SW}}$	I	Not used (Connected to +5V)															
62	$\overline{\text{TAPE SW}}$	I	Not used (Connected to +5V)															
63	$\overline{\text{CAL SW}}$	I	Calibration SW (S602) input "L": CAL mode, "H": Normal mode															
64	ADDR1	O	Data output to display microcomputer (IC601)															



### IC601 Display Microcomputer (M50940-313SP)

This IC controls display of 24-segment level meter, counter, etc. based on the instruction from master microcomputer (IC801).

Pin. No.	Pin Name	I/O	Function
1	Vref	I	Reference voltage input (+5V) to A/D ports
2	$\phi$ L	I	Mechanism deck supply reel table sensor pulse input
3	$\phi$ R	I	Mechanism deck take-up reel table sensor pulse input
4	DATA	I	Data input (analog) from master microcomputer (IC801)
5~6	ADR1~ADR0	I	Data input (analog) from master microcomputer (IC801)
7	KEY	I	Key switch input (analog) 0V : MEMORY 1.6V : RESET 3.1V : DISPLAY
8	LEVEL L	I	Level meter Lch input (analog) from meter amplifier (IC507)
9	LEVEL R	I	Level meter Rch input (analog) from meter amplifier (IC507)
10~15	$\overline{\text{GRID6}} \sim \overline{\text{GRID1}}$	O	FL tube grid output
16	$\overline{\text{C00}}$	O	Negative pulse output when counter is 00
17	$\overline{\text{PLAY}}$	O	PLAY LED output "L" : ON
18	$\overline{\text{PLAY}}$	O	PLAY LED output "L" : ON
19	$\overline{\text{PAUSE}}$	O	PAUSE LED output "L" : ON
20	$\overline{\text{REC}}$	O	REC LED output "L" : ON
21	$\overline{\text{TAPE}}$	O	FL tube segment output (L : TAPE, H : SOURCE display)
22	$\overline{\text{OVER LEVEL}}$	O	FL tube segment output ("OVER LEVEL" display)
23	$\overline{\text{TYPE I}}$	O	FL tube segment output ("TYPE I" display)
24	$\overline{\text{TYPE II}}$	O	FL tube segment output ("TYPE II" display)
25	$\overline{\text{TYPE IV}}$	O	FL tube segment output ("TYPE IV" display)
26	CNVss	-	Power supply (GND)
27	$\overline{\text{RESET}}$	I	RESET input
28	XIN	I	Clock input (4MHz)
29	XOUT	O	Clock output (4MHz)
30	XCIN	-	Not used (Normally "L")
31	XCOU	-	Not used
32	Vss	-	Power supply (GND)
33	$\phi$	O	Not used
34	VER	I	Version switching input (Normally "L")
35	$\overline{\text{TEST}}$	I	TEST mode input "L" : Meter all ON
36	CAL	I	Calibration SW (S602) input "L" : CAL mode, "H" : Normal mode
37	IN	I	Not used
38	VP	I	Pull down power supply (-22V) for FL tube segment output
39~62	S23~S0	O	FL tube segment output (meter, counter display)
63	AVcc	-	Power supply (+5V)
64	Vcc	-	Power supply (+5V)

5-1. BLOCK DIAGRAM

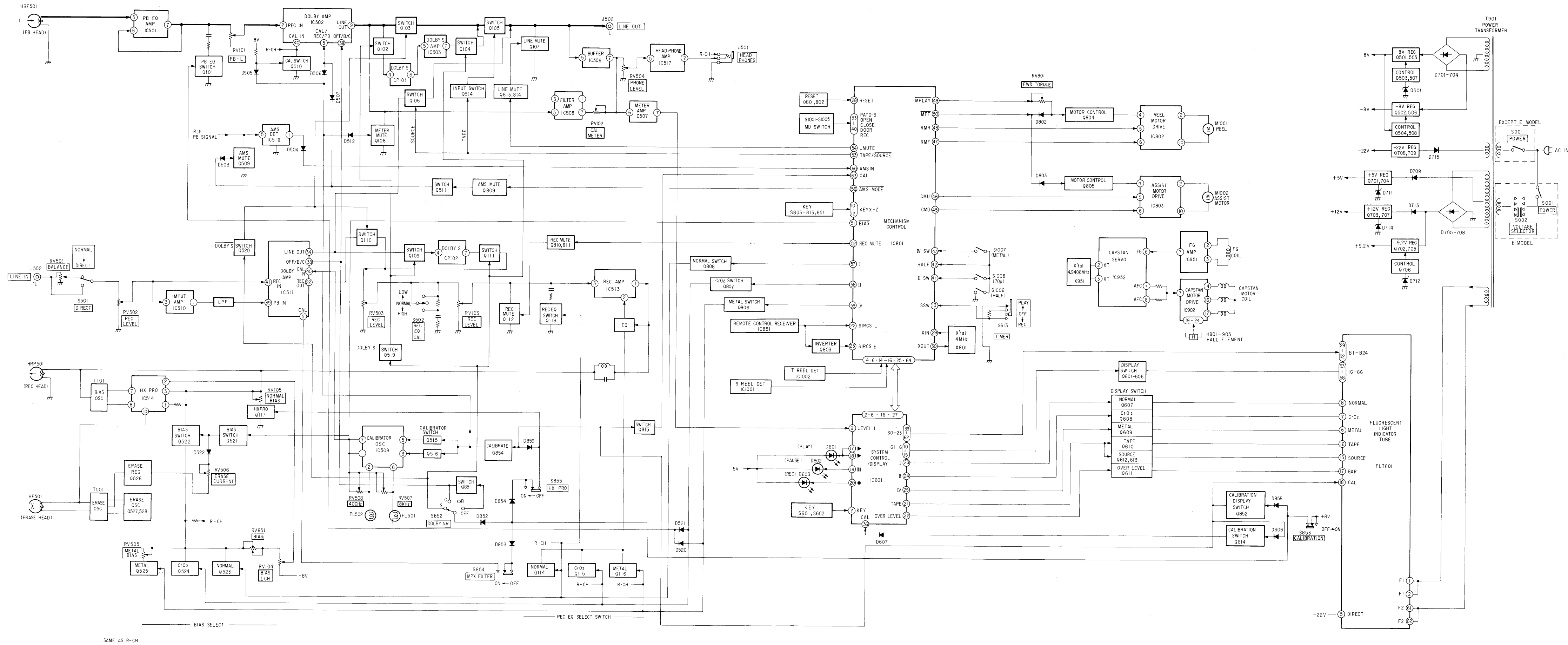

● Semiconductor Location

Ref. No.	Location	Ref. No.	Location	Ref. No.	Location
D101	J-7	IC1	C-21	Q211	B-12
D102	J-7	IC2	G-20	Q212	C-12
D103	G-6	IC501	H-13	Q213	C-13
D104	G-7	IC502	I-10	Q214	C-13
D105	D-6	IC503	I-7	Q215	C-13
D106	E-6	IC506	F-8	Q216	C-13
D107	E-6	IC507	E-6	Q217	C-15
D108	D-12	IC508	J-6	Q501	H-15
D109	E-12	IC509	B-7	Q502	G-15
D201	G-7	IC510	C-7	Q503	I-16
D202	G-7	IC511	C-9	Q504	G-16
D203	G-8	IC513	D-14	Q505	H-16
D204	G-7	IC514	D-16	Q506	G-16
D205	D-6	IC516	F-10	Q507	H-16
D206	E-7	IC517	J-3	Q508	G-16
D207	E-7			Q509	G-12
D208	C-12	Q101	H-12	Q510	G-12
D209	B-12	Q102	J-8	Q511	F-13
D501	H-16	Q103	I-7	Q514	F-8
D503	F-13	Q104	I-7	Q515	C-6
D504	F-9	Q105	G-6	Q516	C-7
D505	G-11	Q106	G-7	Q519	E-10
D506	G-11	Q107	F-7	Q520	E-10
D507	G-11	Q108	J-7	Q521	D-17
D508	J-8	Q109	E-11	Q522	D-17
D509	J-8	Q110	D-12	Q523	E-16
D510	H-8	Q111	E-12	Q524	E-16
D511	H-8	Q112	E-13	Q525	E-16
D512	F-8	Q113	D-13	Q526	B-16
D513	E-8	Q114	D-13	Q527	B-16
D514	C-12	Q115	D-13	Q528	B-15
D515	C-12	Q116	D-13		
D516	E-12	Q117	D-15		
D517	E-12	Q201	G-12		
D518	E-11	Q202	H-8		
D519	E-10	Q203	H-7		
D520	F-13	Q204	G-7		
D521	F-13	Q205	G-7		
D522	B-16	Q206	G-7		
D523	J-8	Q207	F-7		
D524	H-8	Q208	G-7		
D525	C-12	Q209	C-11		
D526	E-12	Q210	D-12		

**Note:**  
 ○ : parts extracted from the component side.  
 ● : parts mounted on the conductor side.  
 ◐ : Through hole.  
 ▨ : Pattern from the side which enables seeing.  
 (The other layers' patterns are not indicated.)

**Caution:**  
 Pattern face side: Parts on the pattern face side seen from (Conductor Side) the pattern face are indicated.  
 Parts face side: Parts on the parts face side seen from the (Component Side) parts face are indicated.

CND: Canadian  
 G: German

5-2. PRINTED WIRING BOARDS—AUDIO Section—

• See page 37 for Circuit Boards Location and Semiconductor Lead Layouts.

• See page 40 for Dolby S Board Schematic Diagram.

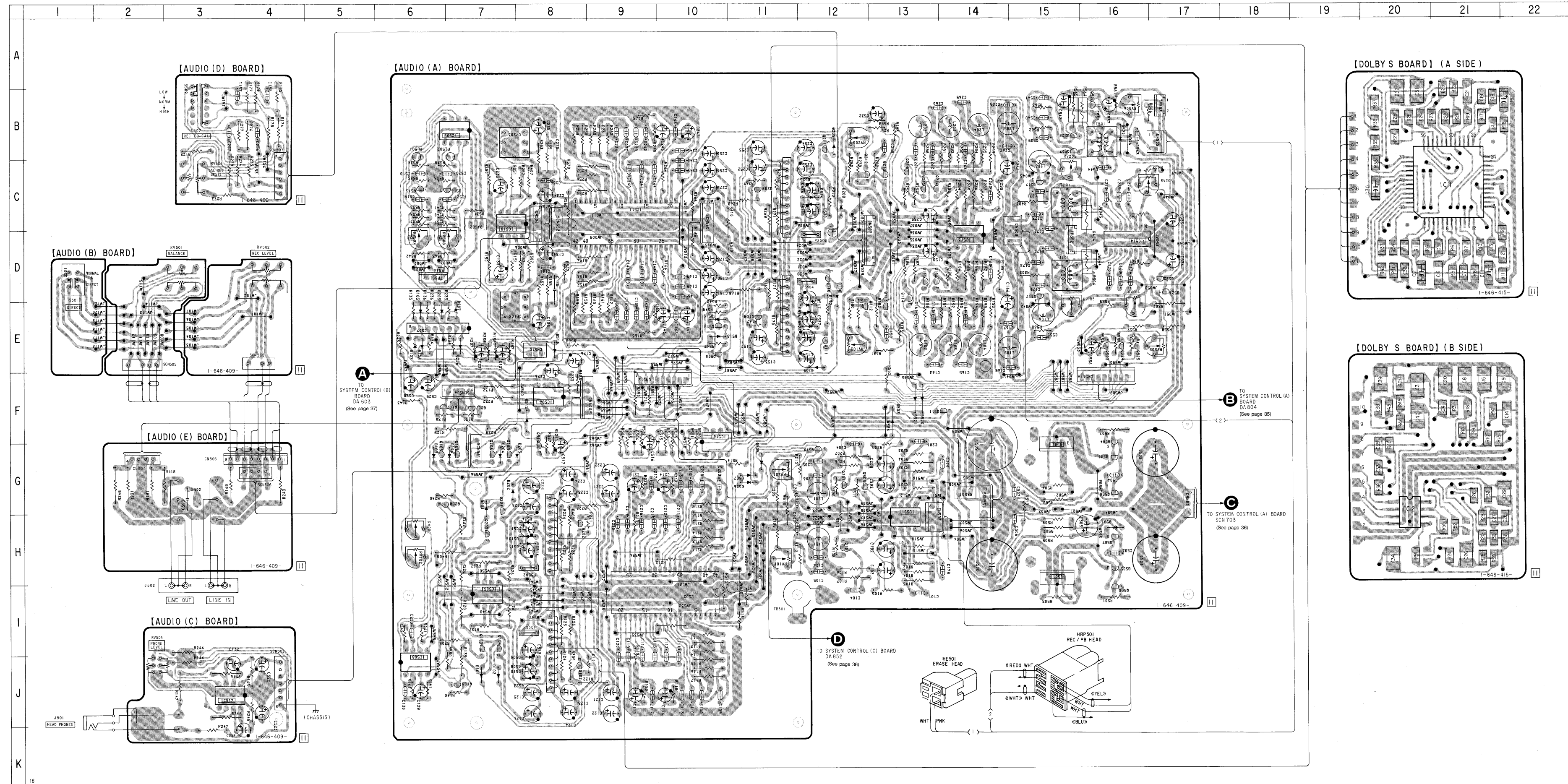



5-3. SCHEMATIC DIAGRAM -AUDIO Section-

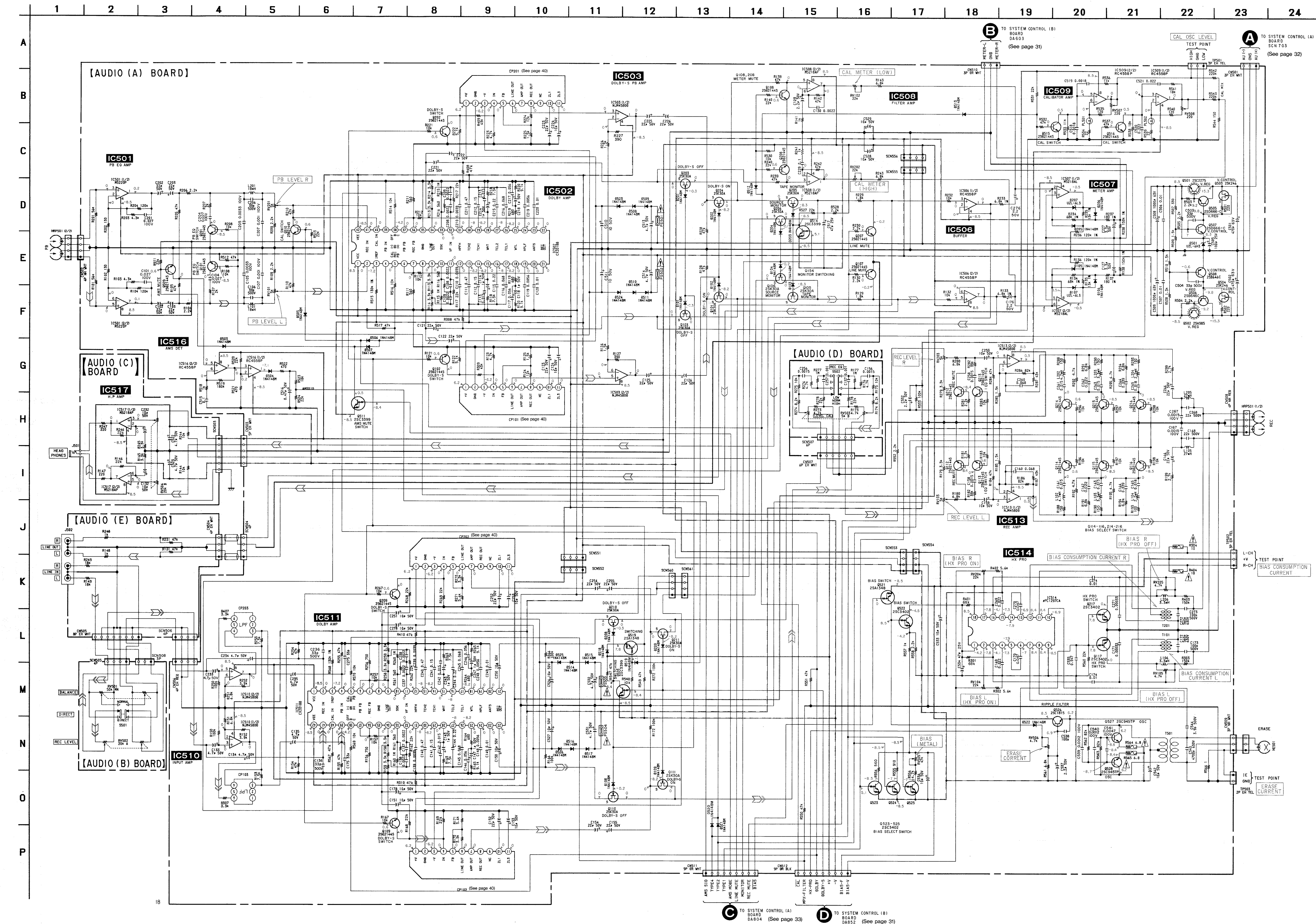

IC Block Diagrams

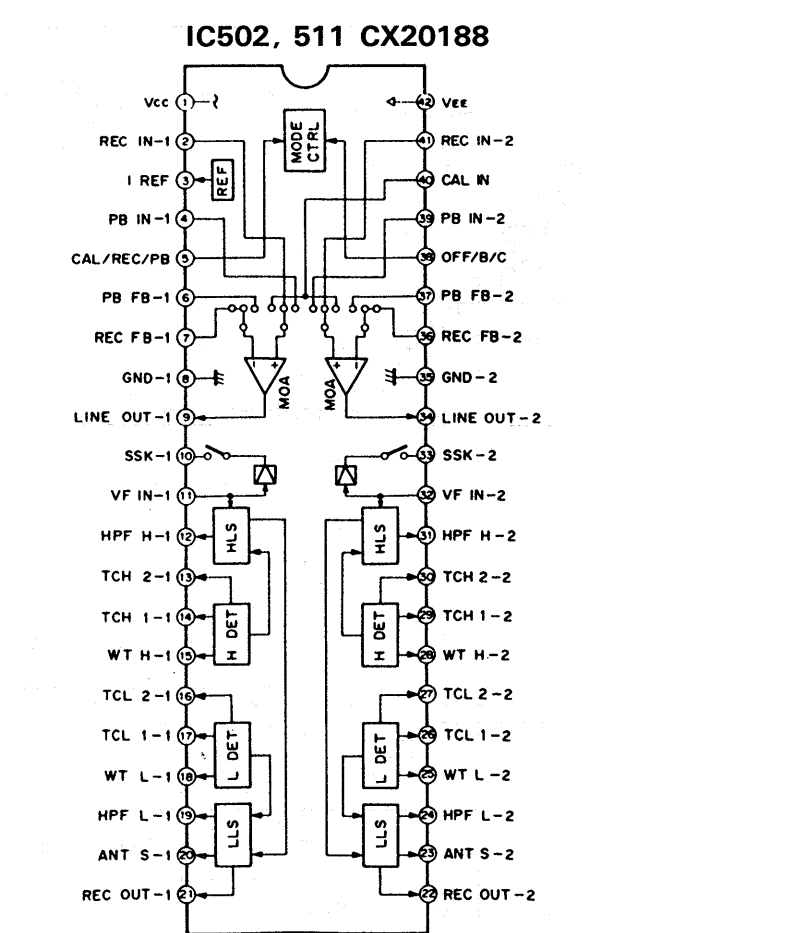
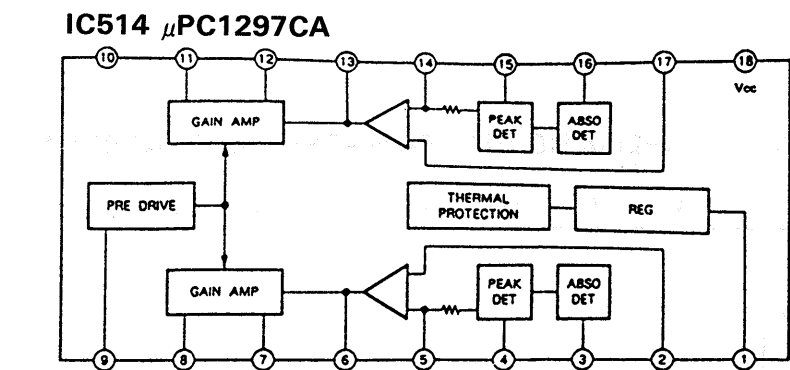

Pin No.	Pin Name	Function
1	Vcc	Positive power supply
2, 41	REC IN	REC input
3	I REF	Reference current input
4, 39	PB IN	PLAYBACK input
5	CAL/REC/PB	CALIBRATION/REC/PLAYBACK switching
6, 37	PB FB	PLAYBACK feedback
7, 36	REC FB	REC feedback
8, 35	GND	GND in 2-power mode, Vcc/2 in 1-power mode
9, 34	LINE OUT	Line out (decode output)
10, 33	SSK	Spectral skewing switch
11, 32	VF IN	Encode circuit input
12, 31	HPF H	HLS high pass filter
13, 30	TCH 2	HLS detector time constant 2
14, 29	TCH 1	HLS detector time constant 1
15, 28	WT H	HLS weighting
16, 27	TCL 2	LLS detector time constant 2
17, 26	TCL 1	LLS detector time constant 1
18, 25	WTL	LLS weighting
19, 24	HPF L	LLS high pass filter
20, 23	ANT S	Anti-saturation
21, 22	RED OUT	REC output (encode output)
38	OFF/B/C	DOLBY NR OFF/B type/C type switching
40	CAL IN	CALIBRATION input
42	Vee	Negative power supply in 2-power mode, GND in 1-power mode

**Note:**  
 • All capacitors are in  $\mu\text{F}$  unless otherwise noted.  $\text{pF}$ :  $\mu\text{F}$  50WV or less are not indicated except for electrolytics and tantalums.  
 • All resistors are in  $\Omega$  and  $\frac{1}{2}\text{W}$  or less unless otherwise specified.  
 • % : indicates tolerance.  
 •  $\Delta$  : internal component.  
 •  $\square$  : nonflammable resistor.  
 •  $\text{---}$  : fusible resistor.

**Note:**  
 The components identified by mark  $\Delta$  or dotted line with mark  $\Delta$  are critical for safety. Replace only with part number specified.

**Note:**  
 Les composants identifiés par une marque  $\Delta$  sont critiques pour la sécurité. Ne les remplacer que par une pièce portant le numéro spécifié.

• — : B+ Line  
 • — : B- Line  
 • — : adjustment for repair.  
 • Voltage is dc with respect to ground under no-signal conditions.  
 • Voltages are taken with a VOM (Input Impedance 10M $\Omega$ ). Voltage variations may be noted due to normal production tolerances.  
 • Signal path.  
 •  $\text{---}$  : PB  
 •  $\text{---}$  : REC

5-4. SCHEMATIC DIAGRAM—SYSTEM CONTROL Section—

1 2 3 4 5 6 7 8 9 10 11 12 13 14 15 16 17 18 19 20 21 22 23 24 25 26 27 28

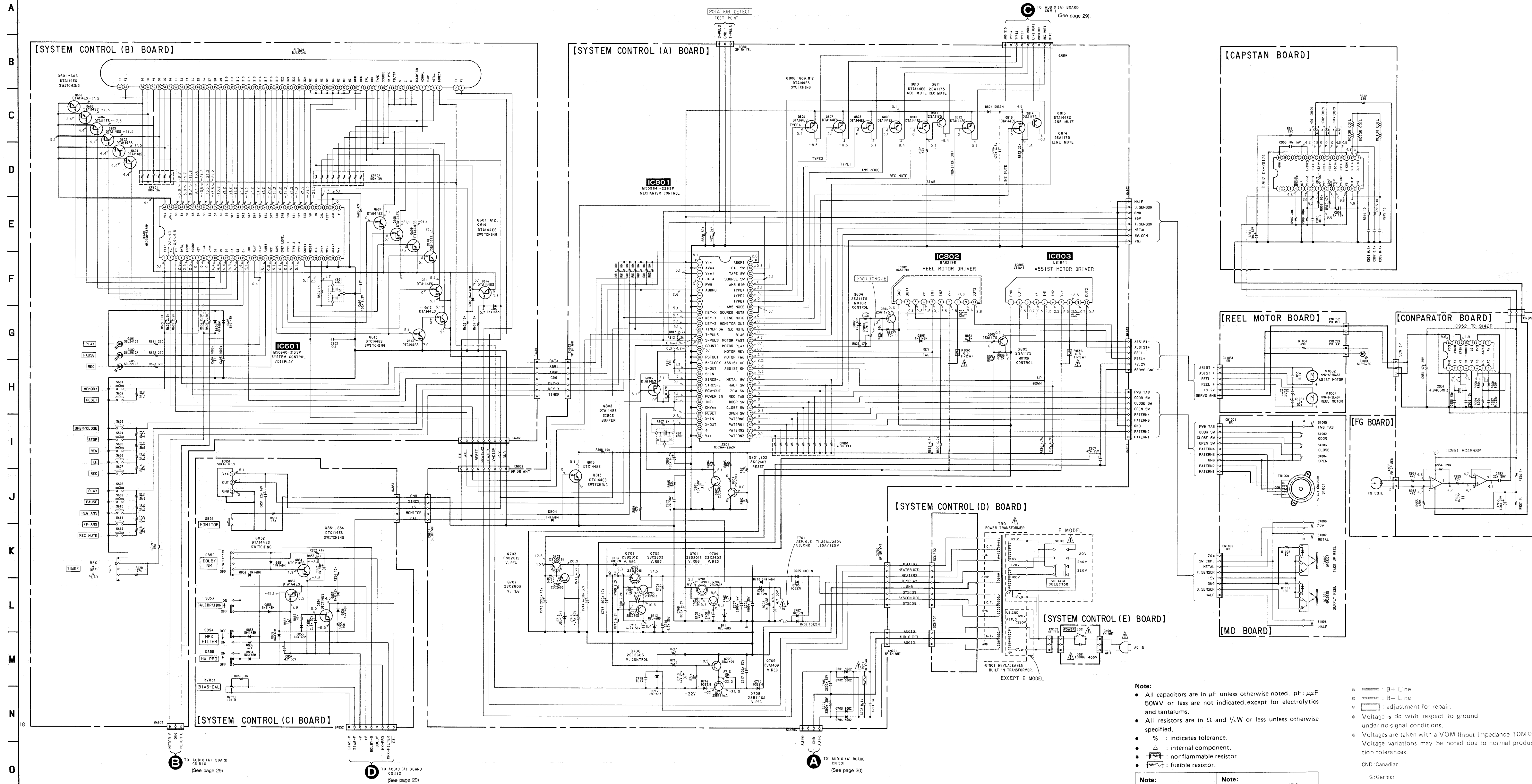

IC Block Diagrams

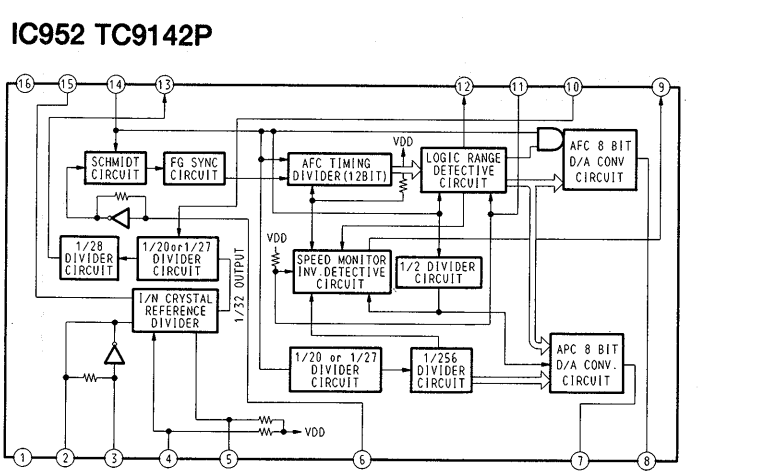
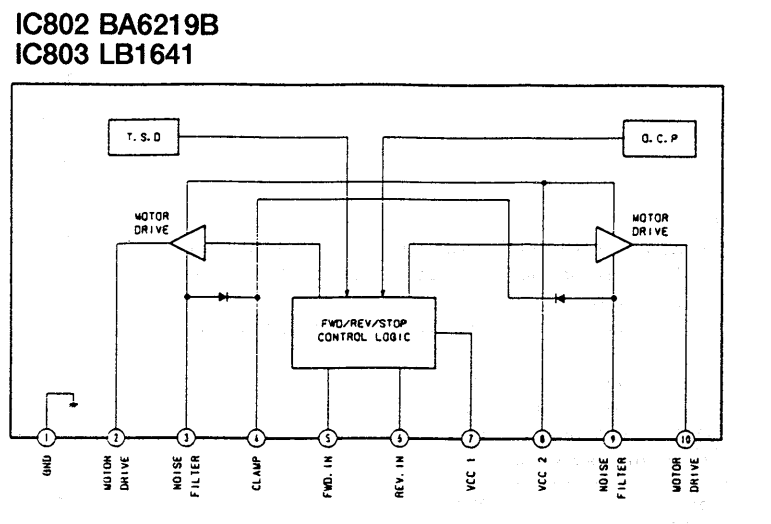
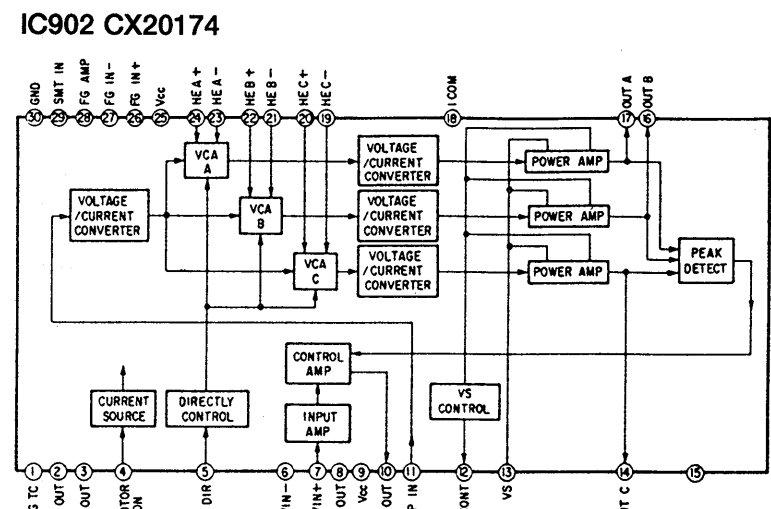

- Note:**
- All capacitors are in  $\mu\text{F}$  unless otherwise noted.  $\text{pF}$  :  $\mu\text{F}$  is 50WV or less are not indicated except for electrolytics and tantalums.
  - All resistors are in  $\Omega$  and  $1/4\text{W}$  or less unless otherwise specified.
  - % : indicates tolerance.
  - $\Delta$  : internal component.
  - $\square$  : nonflammable resistor.
  - $\text{---}$  : fusible resistor.

**Note:** The components identified by mark  $\Delta$  or dotted line with mark  $\Delta$  are critical for safety. Replace only with part number specified.

**Note:** Les composants identifiés par une marque  $\Delta$  sont critiques pour la sécurité. Ne les remplacer que par une pièce portant le numéro spécifié.

- $\text{---}$  : B+ Line
  - $\text{---}$  : B- Line
  - $\text{---}$  : adjustment for repair.
  - Voltage is dc with respect to ground under no-signal conditions.
  - Voltages are taken with a VOM (input impedance 10M $\Omega$ ). Voltage variations may be noted due to normal production tolerances.
- GND: Canadian  
 G: German



5-5. PRINTED WIRING BOARDS—SYSTEM CONTROL Section— • See page 37 for Circuit Boards Location and Semiconductor Lead Layouts.

• Semiconductor Location

Ref. No.	Location	Ref. No.	Location
D601	I-16	IC952	J-2
D602	J-16	IC1001	H-10
D603	J-14	IC1002	H-9
D604	H-18		
D605	H-18	Q601	G-18
D606	H-14	Q602	G-18
D607	G-16	Q603	G-18
D701	B-7	Q604	H-18
D702	B-7	Q605	H-18
D703	B-8	Q606	H-18
D704	B-7	Q607	G-14
D705	C-7	Q608	G-14
D706	C-7	Q609	H-14
D707	B-6	Q610	G-14
D708	B-6	Q611	G-15
D709	C-7	Q612	H-15
D710	E-5	Q613	H-15
D711	C-9	Q614	H-14
D712	D-8	Q701	C-9
D713	E-7	Q702	D-8
D714	E-8	Q703	E-8
D715	D-6	Q704	B-9
D716	D-6	Q705	D-9
D717	D-6	Q706	D-8
D801	D-3	Q707	E-9
D802	D-3	Q708	D-6
D803	D-3	Q709	D-6
D804	E-3	Q801	B-5
D851	A-11	Q802	B-5
D852	B-11	Q803	B-4
D853	B-11	Q804	D-4
D854	B-12	Q805	D-4
D855	C-11	Q806	D-2
D856	E-12	Q807	D-2
D857	E-12	Q808	D-2
D858	B-12	Q809	D-2
D859	B-12	Q810	D-3
		Q811	D-3
IC601	G-17	Q812	D-3
IC801	C-3	Q813	D-3
IC802	D-4	Q814	D-2
IC803	D-4	Q815	C-1
IC851	D-11	Q851	D-11
IC902	J-6	Q852	B-12
IC951	J-3	Q854	D-12

Note:  
 • — : parts extracted from the component side.  
 • ■ : parts mounted on the conductor side.  
 • ▨ : Pattern on the side which is seen.  
 CND: Canadian  
 G: German

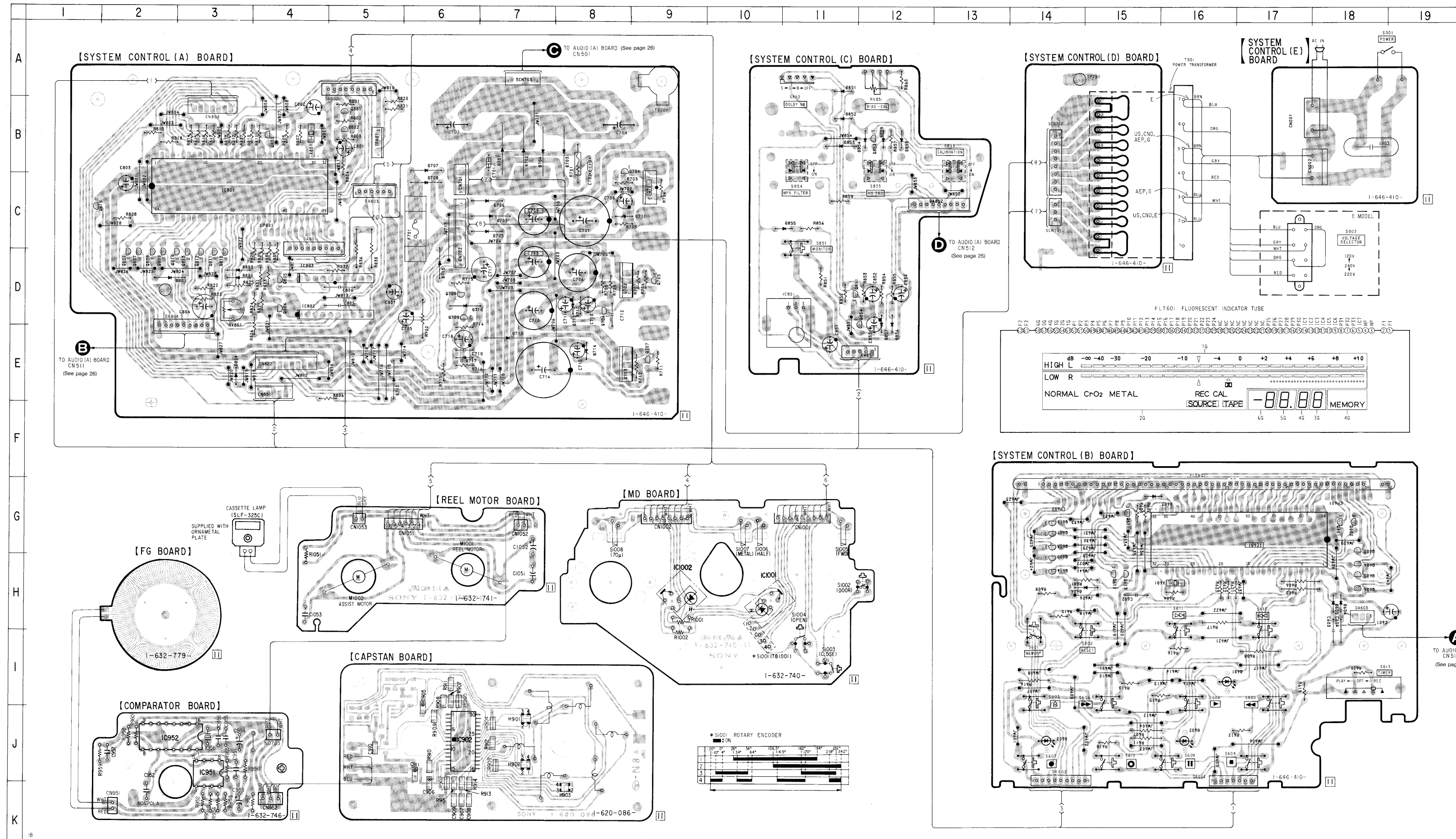

5-6. SEMICONDUCTOR LEAD LAYOUTS

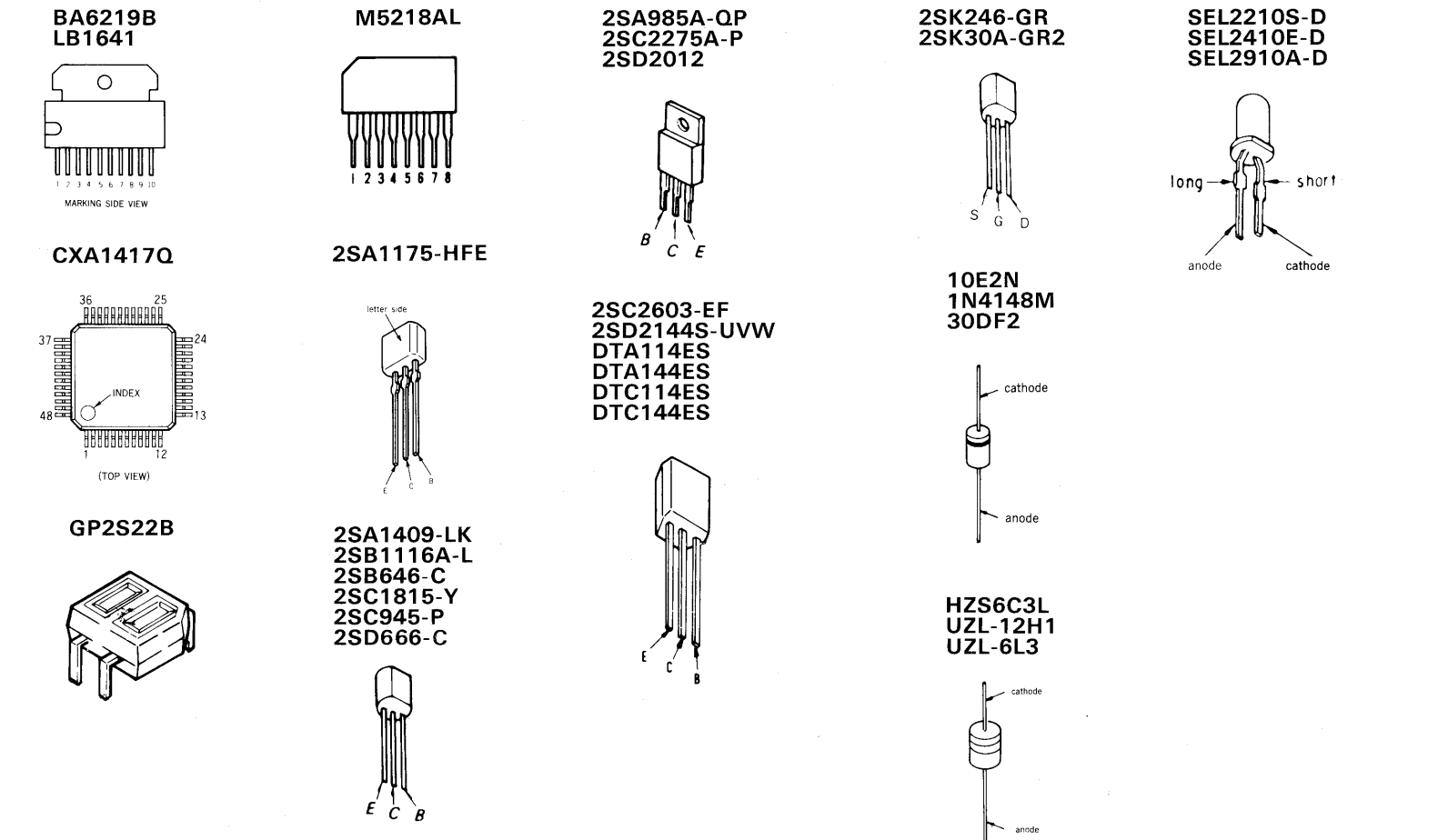

5-7. CIRCUIT BOARDS LOCATION

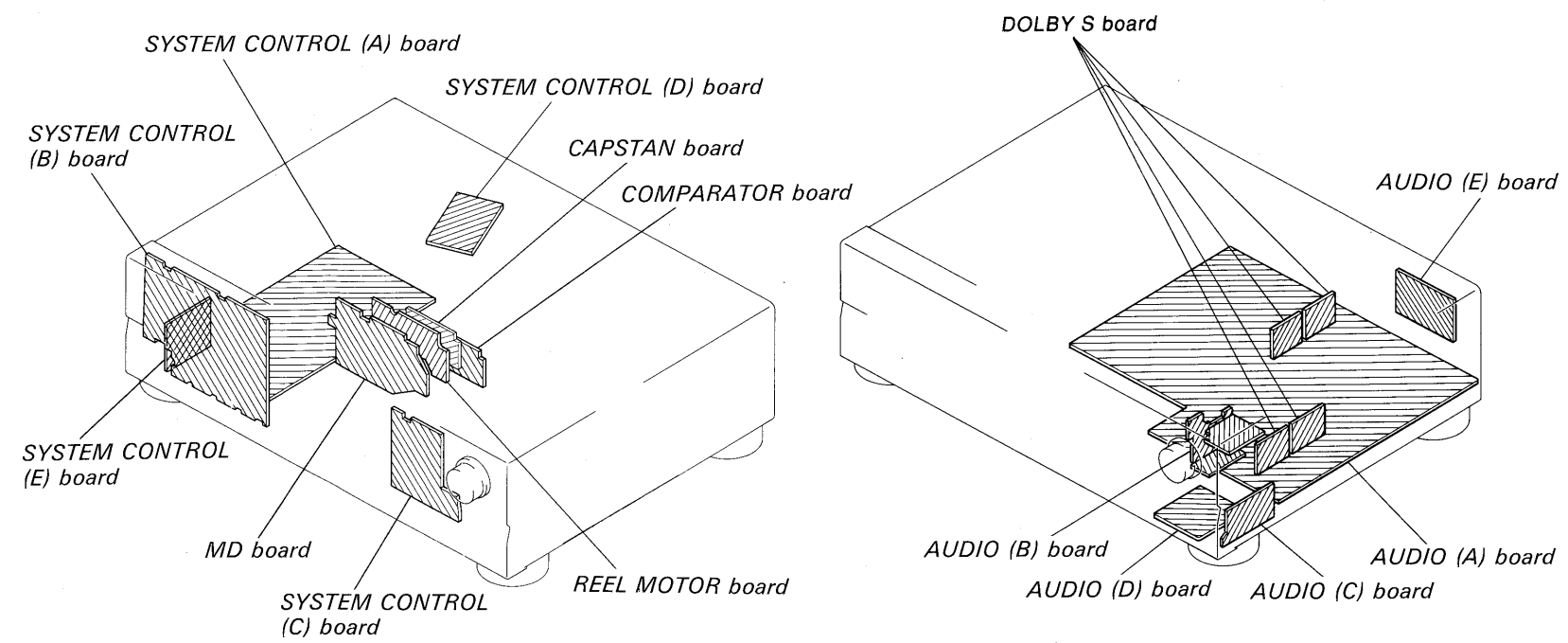

• IC Block Diagram

IC1 CXA1417Q

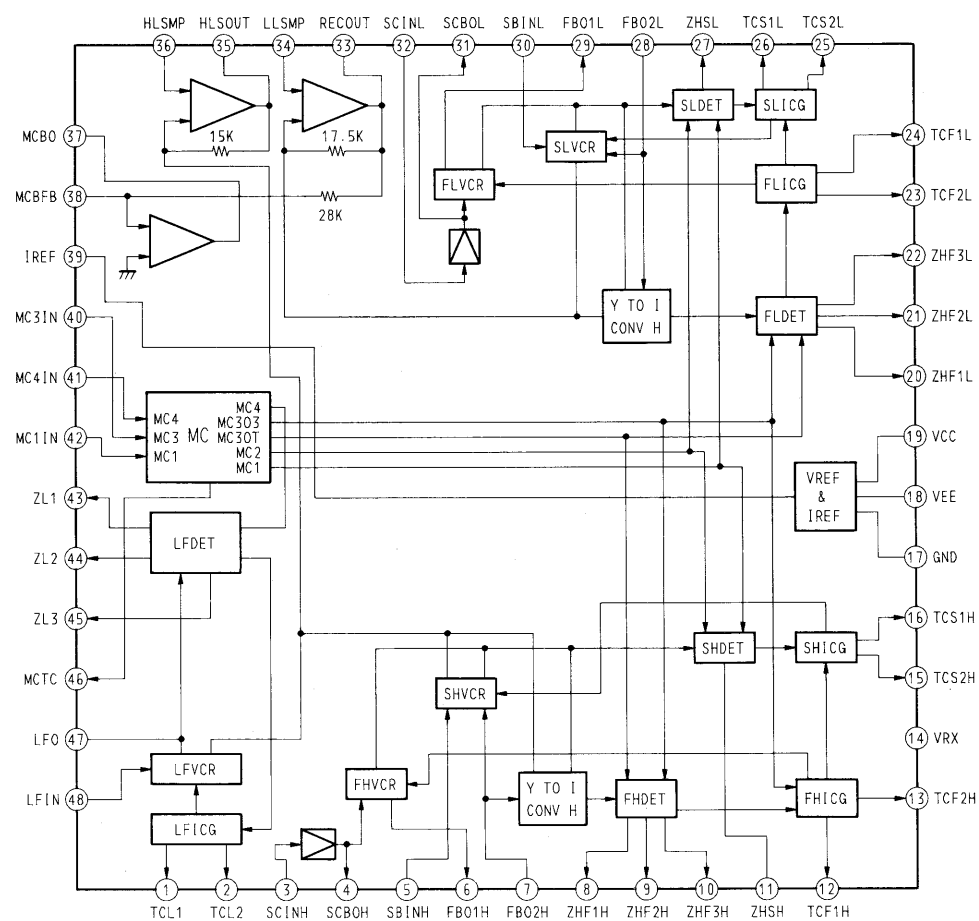

Note:

- All capacitors are in  $\mu$ F unless otherwise noted. pF:  $\mu$ pF
- 50WV or less are not indicated except for electrolytics and tantalums.
- All resistors are in  $\Omega$  and  $\frac{1}{4}$ W or less unless otherwise specified.
- % : indicates tolerance.
- ○ : B+ Line
- □ : B- Line
- Voltage is dc with respect to ground under no-signal conditions.
- Voltages are taken with a VOM (Input Impedance 10M $\Omega$ ). Voltage variations may be noted due to normal production tolerances.
- Signal path.
- ⇨ : PB
- ⇨⇨ : REC

5-8. SCHEMATIC DIAGRAM —DOLBY S Section—

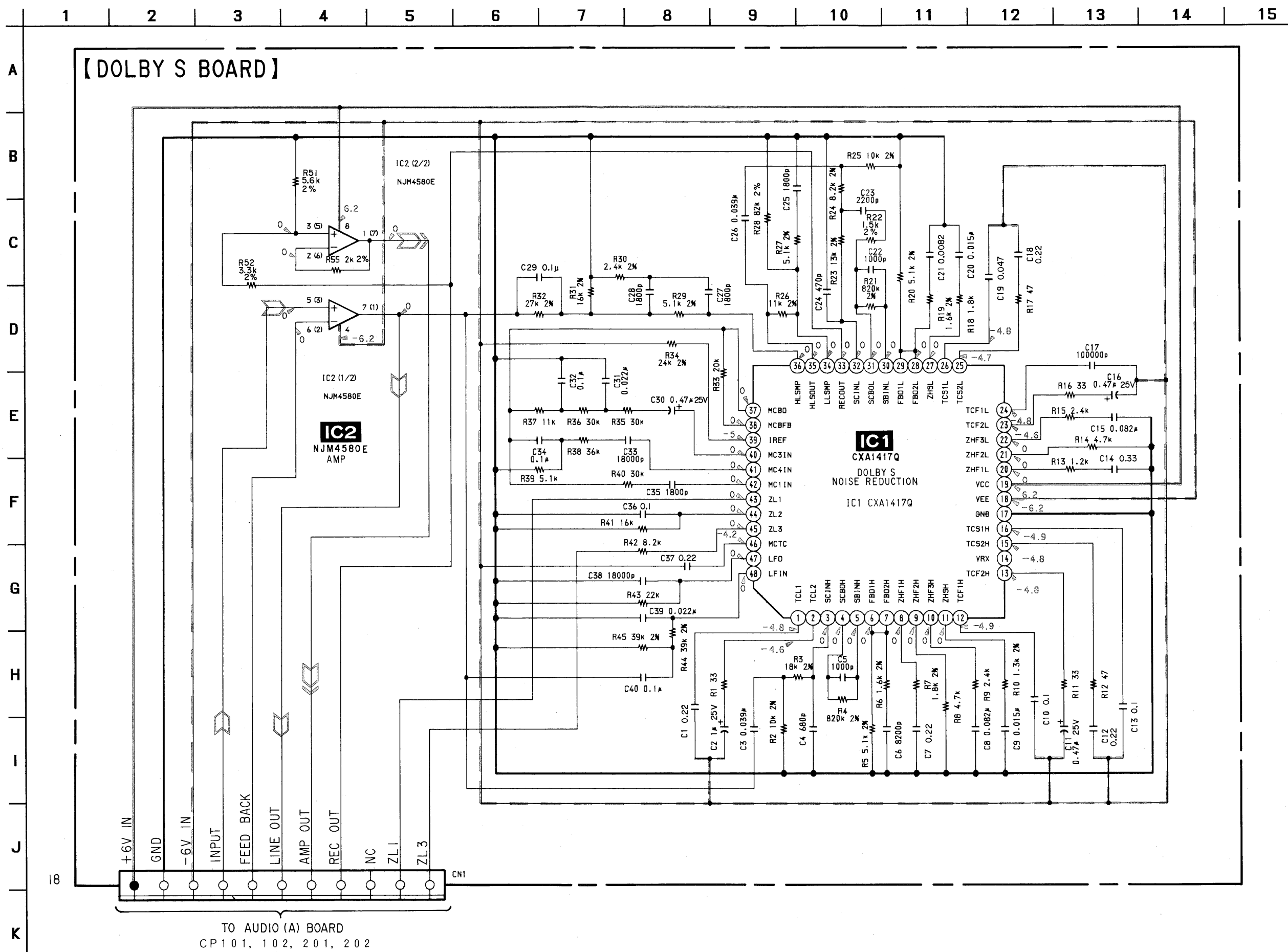

# SECTION 6 EXPLODED VIEWS

**NOTE:**

- -XX, -X mean standardized parts, so they may have some differences from the original one.
- Color Indication of Appearance Parts  
Example:  
KNOB, BALANCE (WHITE)... (RED)  
          ↑                  ↑  
      Parts color      Cabinet's color

- Items marked " \* " are not stocked since they are seldom required for routine service. Some delay should be anticipated when ordering these items.
- The mechanical parts with no reference number in the exploded views are not supplied.
- Hardware (#mark) list is given in the last of this parts list.

The components identified by mark  $\triangle$  or dotted line with mark  $\triangle$  are critical for safety. Replace only with part number specified.

Les composants identifiés par une marque  $\triangle$  sont critiques pour la sécurité. Ne les remplacer que par une pièce portant le numéro spécifié.

## 6-1. PANEL SECTION

- **B** : SYSTEM CONTROL (B) board
- **E** : SYSTEM CONTROL (E) board

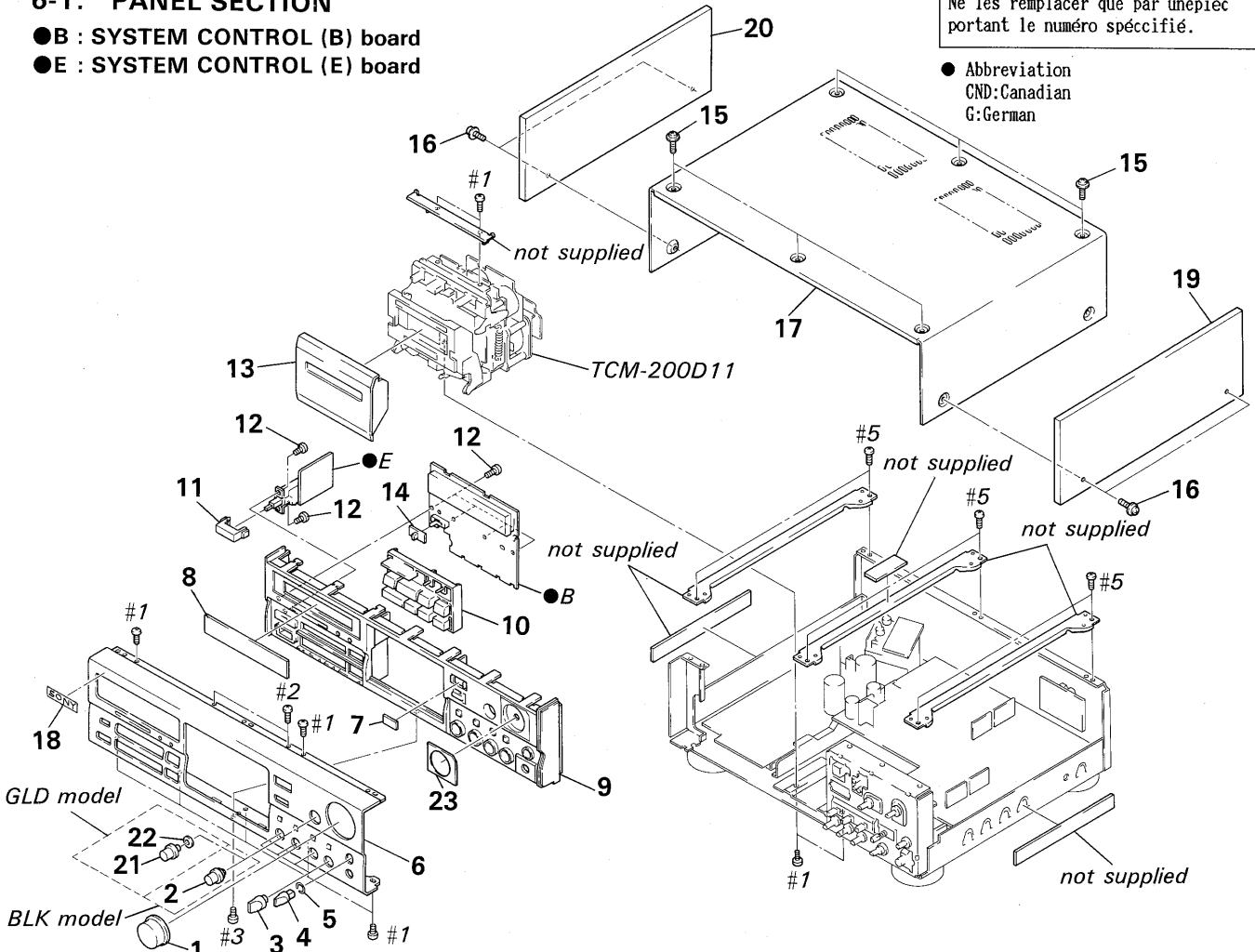

● Abbreviation  
CND: Canadian  
G: German

Ref. No.	Part No.	Description	Remark
1	X-3362-289-1	KNOB (VOL) ASSY (BLK)	
1	X-3365-344-1	KNOB (VOL) ASSY (GLD)	
2	X-3365-387-1	KNOB (BAL) ASSY (B) (BLK)	
3	X-3362-818-1	KNOB (DIA. 12) ASSY (B), FLAT (BLK)	
3	X-3363-490-1	KNOB (DIA. 12) ASSY (B), FLAT (GLD)	
4	3-354-931-01	KNOB (DIA. 10) (BLK)	
4	3-354-931-31	KNOB (DIA. 10) (GLD)	
5	3-354-981-01	SPRING (SUS), RING (BLK)	
5	3-356-935-01	SPRING (SUS), RING (GLD)	
6	3-385-609-11	PANEL, FRONT (US, CND)	
6	3-385-609-21	PANEL, FRONT (AEP, G:BLK)	
6	3-385-609-31	PANEL, FRONT (GLD)	
6	3-385-609-61	PANEL, FRONT (E)	
7	3-385-600-01	WINDOW (R)	
8	3-385-605-01	WINDOW (METER)	
* 9	3-384-775-01	PANEL (BASE) (BLK)	
* 9	3-384-775-11	PANEL (BASE) (GLD)	
10	X-3366-040-1	BUTTON (BLOCK) ASSY (BLK)	
10	X-3366-750-1	BUTTON (BLOCK) ASSY (N) (GLD)	
11	3-354-932-01	BUTTON (POWER) (BLK)	
11	3-354-932-11	BUTTON (POWER) (GLD)	
12	4-951-620-01	SCREW (2.6X8), +BVTP	
13	X-3366-748-1	LID ASSY (F), CASSETTE (AEP, G:BLK, E)	

Ref. No.	Part No.	Description	Remark
13	X-3366-749-1	LID ASSY (G), CASSETTE (GLD)	
13	X-3366-751-1	LID ASSY (H), CASSETTE (US, CND)	
14	4-922-518-01	KNOB (TIMER) (BLK)	
14	4-922-518-62	KNOB (TIMER) (GLD)	
15	3-704-366-11	SCREW (CASE) (M3X8) (GLD)	
15	3-704-366-01	SCREW (CASE) (M3X8) (BLK)	
16	4-933-446-01	SCREW (SIDE PANEL)	
* 17	3-364-366-01	CASE (BLK)	
* 17	3-364-366-41	CASE (GLD)	
18	4-942-568-01	EMBLEM (NO. 5), SONY (BLK)	
18	4-942-568-11	EMBLEM (NO. 5), SONY (GLD)	
19	X-3340-188-1	PANEL (R) ASSY, SIDE (US, CND, E, AEP:BLK)	
19	X-3362-386-1	PANEL (R) ASSY, SIDE (G:BLK)	
19	X-3363-178-2	PANEL (R) ASSY, SIDE (GLD)	
20	X-3340-187-1	PANEL (L) ASSY, SIDE (US, CND, E, AEP:BLK)	
20	X-3362-385-1	PANEL (L) ASSY, SIDE (G:BLK)	
20	X-3363-177-2	PANEL (L) ASSY, SIDE (GLD)	
21	3-364-173-21	KNOB (BAL) (GLD)	
22	3-356-957-01	SPRING (GLD)	
23	3-364-166-01	PLATE (VOL), ORNAMENTAL (BLK)	
23	3-364-166-11	PLATE (VOL), ORNAMENTAL (GLD)	



## 6-2. CHASSIS SECTION

- C : SYSTEM CONTROL (C) board
- D : SYSTEM CONTROL (D) board
- B : AUDIO (B) board
- C : AUDIO (C) board
- D : AUDIO (D) board
- E : AUDIO (E) board

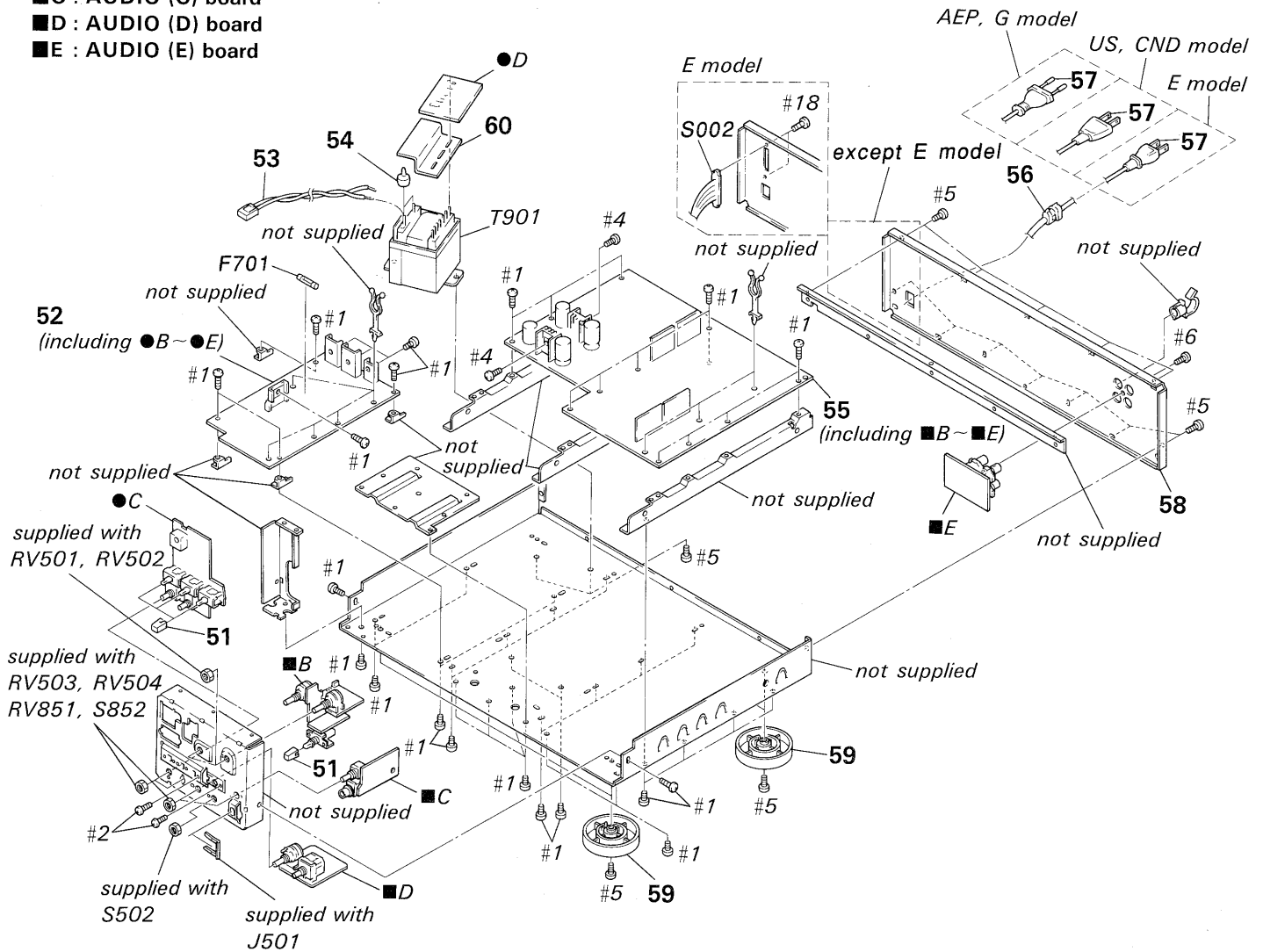

<p>The components identified by mark <math>\triangle</math> or dotted line with mark <math>\triangle</math> are critical for safety. Replace only with part number specified.</p>	<p>Les composants identifiés par une marque <math>\triangle</math> sont critiques pour la sécurité. Ne les remplacer que par une pièce portant le numéro spécifié.</p>
---	--

Ref. No.	Part No.	Description	Remark
51	3-380-952-01	BUTTON (BLK)	
51	3-380-952-11	BUTTON (GLD)	
* 52	A-2006-998-A	SYSTEM CONTROL BOARD, COMPLETE	
* 53	1-590-321-61	LEAD (WITH CONNECTOR)	
* 54	3-356-961-02	COVER (TRANSFORMER) (E)	
* 54	4-912-962-01	COVER (1P), TERMINAL (EXCEPT E)	
* 55	A-2006-898-A	AUDIO BOARD, COMPLETE (EXCEPT CND)	
* 55	A-2006-997-A	AUDIO BOARD, COMPLETE (CND)	
* 56	3-703-244-00	BUSHING (2104), CORD (EXCEPT E)	
* 56	3-703-571-11	BUSHING (S) (4516), CORD (E)	
$\triangle$ 57	1-558-568-21	CORD, POWER (AEP, G)	
$\triangle$ 57	1-559-583-21	CORD, POWER (US, CND)	
$\triangle$ 57	1-696-027-11	CORD, POWER (E)	

Ref. No.	Part No.	Description	Remark
* 58	3-384-774-11	PANEL, BACK (US, CND)	
* 58	3-384-774-21	PANEL, BACK (AEP, G:BLK)	
* 58	3-384-774-31	PANEL, BACK (GLD)	
* 58	3-384-774-41	PANEL, BACK (E)	
59	X-3304-944-1	FOOT ASSY (BLK)	
59	X-3363-489-1	FOOT ASSY (GLD)	
* 60	3-356-961-02	COVER (TRANS) (E)	
$\triangle$ F701	1-532-285-00	FUSE, TIME-LAG (1.25A/250V) (AEP, G, E)	
$\triangle$ F701	1-532-741-11	FUSE, GLASS TUBE (1.25A/125V) (US, CND)	
$\triangle$ S002	1-692-155-11	SELECTOR, POWER VOLTAGE (E)	
$\triangle$ T901	1-423-684-11	TRANSFORMER, POWER (US, CND)	
$\triangle$ T901	1-423-685-11	TRANSFORMER, POWER (AEP, G)	
$\triangle$ T901	1-423-686-11	TRANSFORMER, POWER (E)	

6-3. MECHANISM SECTION-1  
(TCM-200D11)

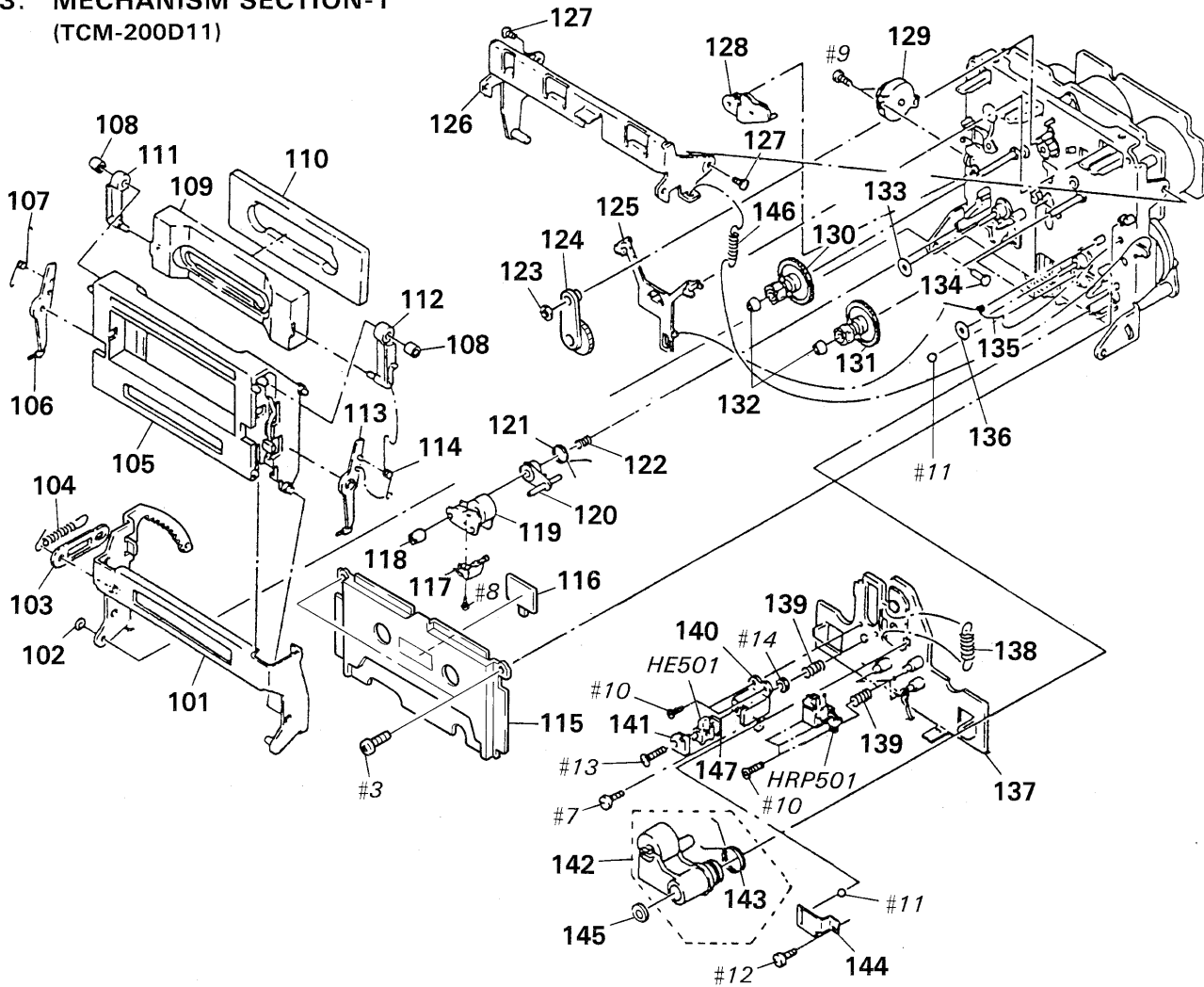

Ref. No.	Part No.	Description	Remark
101	X-3362-671-1	HOLDER (BG) ASSY, CASSETTE	
102	3-558-708-11	WASHER, STOPPER	
* 103	3-356-717-01	LEVER (JOINT)	
104	3-356-626-01	SPRING, TENSION	
105	X-3365-065-1	HOLDER (D9) ASSY, CASSETTE	
106	3-356-932-01	LEVER (LA)	
107	3-356-927-01	SPRING (LEFT), TORSION	
108	3-356-946-01	BUSHING	
109	3-356-928-11	PLATE (A), ORNAMENTAL	
* 110	3-356-929-01	ABSORBENT, VIBRATION	
111	3-356-933-01	LEVER (LB)	
112	3-356-931-01	LEVER (RB)	
113	3-356-930-01	LEVER (RA)	
114	3-356-926-01	SPRING (RIGHT), TORSION	
115	X-3356-613-1	PLATE ASSY, ORNAMENTAL	
116	8-719-980-85	DIODE SLF325C	
117	3-389-445-01	GUIDE (SL), TAPE	
118	3-356-652-01	NUT (PINCH LEVER S)	
119	X-3356-621-1	LEVER (PINCH LEVER S) ASSY	
120	3-356-660-01	LEVER (PS)	
121	3-356-661-01	SPRING (PINCH LEVER S), TORSION	
122	3-356-657-01	SPRING (PS), COMPRESSION	
123	3-669-465-11	WASHER (1.5), STOPPER	
124	X-3356-641-1	LEVER (FR2) ASSY	
125	3-356-614-01	SLIDER (BRAKE)	

Ref. No.	Part No.	Description	Remark
* 126	X-3356-608-1	LEVER (LIFTER) ASSY	
127	3-356-601-11	SCREW, STEP	
128	X-3356-623-1	LEVER (BT) ASSY	
129	3-319-224-41	DAMPER, SMALL	
130	X-3356-629-1	GEAR (S) ASSY	
131	X-3356-627-1	GEAR (T) ASSY	
132	3-362-308-01	CAP (REEL)	
133	3-356-713-01	WASHER	
134	3-356-710-01	SHAFT (LEFT) (CASSETTE HOLDER)	
135	3-356-619-01	SPRING (B), TORSION	
136	3-332-763-01	RING, OIL RESERVOIR	
* 137	X-3362-199-1	SLIDER (HEAD CHASSIS D) ASSY	
138	3-356-658-01	SPRING (LIMITER H), TENSION	
139	3-564-121-00	SPRING, COMPRESSION	
* 140	3-576-977-00	BRACKET, E. HEAD	
141	3-318-433-01	SPRING	
142	X-3356-620-1	LEVER (PINCH LEVER T) ASSY	
143	3-356-672-01	SPRING (PINCH LEVER T), TORSION	
144	3-356-656-01	SPRING (HEAD PC BOARD), LEAF	
145	3-669-596-00	WASHER (2.3), STOPPER	
146	3-376-854-01	SPRING, TENSION	
* 147	1-608-268-00	PC BOARD, ERASE HEAD	
HE501	1-543-836-11	HEAD, MAGNETIC (ERASE)	
HRP501	1-543-684-21	HEAD, MAGNETIC (REC/PB)	

**6-4. MECHANISM SECTION-2**  
(TCM-200D11)

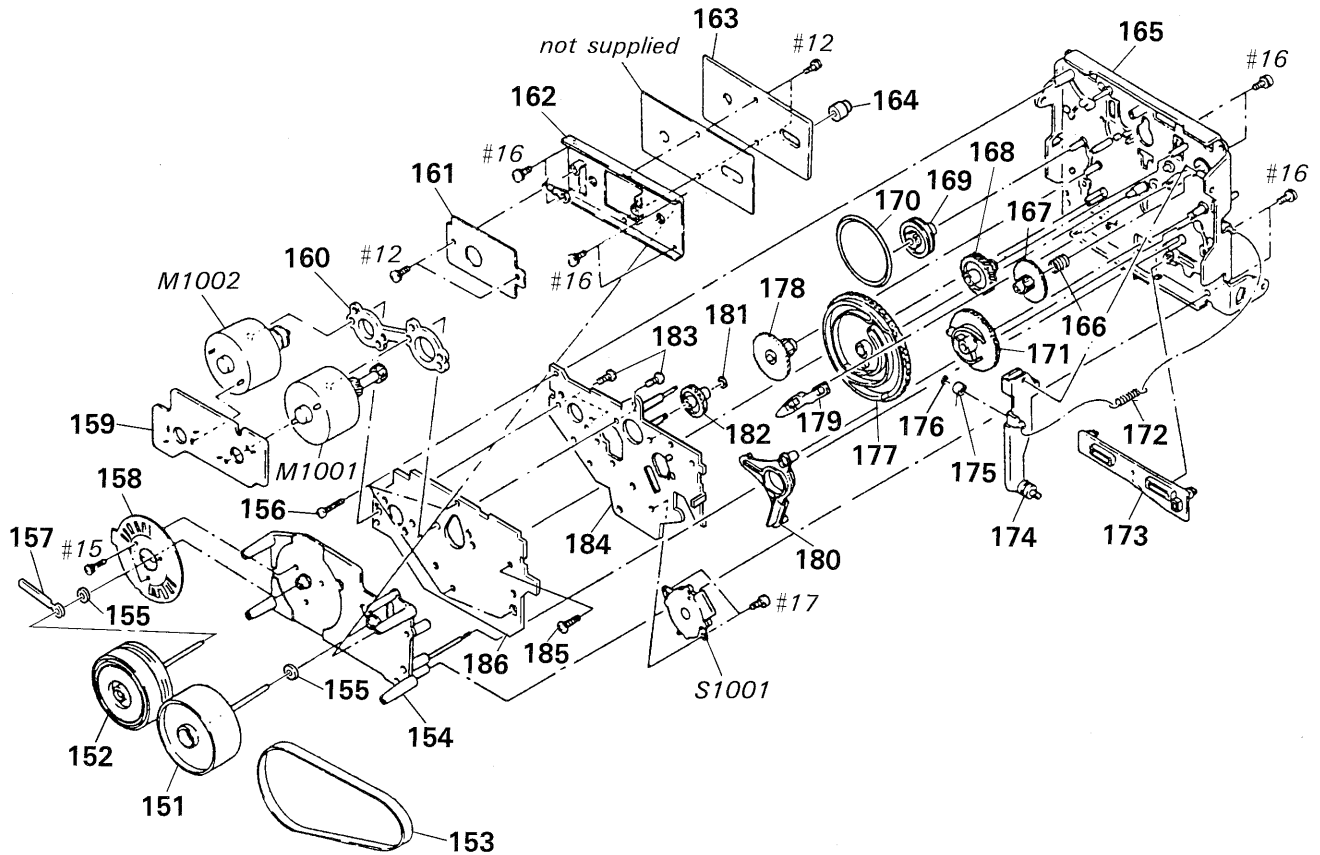

Ref. No.	Part No.	Description	Remark	Ref. No.	Part No.	Description	Remark
151	X-3362-284-1	FLYWHEEL (S2.3) ASSY		171	3-356-616-01	GEAR (LOADING CAM)	
152	X-3356-619-1	FLYWHEEL (DT) ASSY		172	3-356-625-01	SPRING, TENSION	
153	3-364-600-01	BELT (CAPSTAN)		173	3-356-653-01	SLIDER (PAUSE)	
154	X-3362-281-1	CHASSIS (D2.3) ASSY		* 174	X-3356-606-1	LEVER (LOADING) ASSY	
155	3-356-705-31	WASHER (CAPSTAN)		175	3-356-630-01	ROLLER (LOADING)	
156	3-381-811-01	SCREW (PTPWH) (2X18)		176	3-558-708-21	WASHER, STOPPER	
157	3-703-150-11	STOPPER, WIRING		177	3-356-654-01	GEAR (MODE CAM C)	
158	1-632-779-11	PC BOARD, FG		178	3-356-606-01	GEAR (MODE)	
* 159	1-632-741-11	REEL MOTOR BOARD		179	3-356-617-01	LEVER (SELECTION)	
* 160	3-356-628-01	SPACER (MOTOR)		180	3-356-613-01	LEVER (MODE)	
* 161	1-632-746-11	COMPARATOR BOARD		181	3-669-465-00	WASHER (1.5), STOPPER	
* 162	X-3362-282-1	BRACKET (THRUST RETAINER) ASSY		182	3-356-702-01	GEAR (COMMUNICATION B)	
163	A-2006-154-A	CAPSTAN C. O. C BOARD, COMPLETE		183	3-363-804-01	SCREW (+P 2.6X6.5)	
164	3-364-135-01	RETAINER (S), THRUST		* 184	X-3356-616-1	BRACKET (MOTOR D) ASSY	
165	X-3356-622-1	CHASSIS (C) ASSY, MECHANICAL		185	3-356-707-01	SCREW (+PTPWH 2X25)	
166	3-356-605-01	SPRING, COMPRESSION		* 186	1-632-740-11	MD BOARD	
167	3-356-609-01	GEAR (LOADING)		M1001	X-3356-638-1	MOTOR (REEL R) ASSY	
168	3-356-703-01	GEAR (COMMUNICATION C)		M1002	X-3356-604-1	MOTOR (ASSIST) ASSY	
169	3-356-607-01	PULLEY (MODE)		S1001	1-466-238-11	ENCODER, ROTARY	
170	3-356-603-01	BELT (MODE)					

# SECTION 7 ELECTRICAL PARTS LIST

**AUDIO**

**DOLBY S**

**NOTE:**

- Due to standardization, replacements in the parts list may be different from the parts specified in the diagrams or the components used on the set.
- -XX and -X mean standardized parts, so they may have some difference from the original one.
- RESISTORS  
All resistors are in ohms.  
METAL: Metal-film resistor.  
METAL OXIDE: Metal oxide-film resistor.  
F: nonflammable

- Items marked "\*" are not stocked since they are seldom required for routine service. Some delay should be anticipated when ordering these items.
- SEMICONDUCTORS  
In each case, u:  $\mu$ , for example:  
uA.:  $\mu$ A. uPA.:  $\mu$ PA.  
uPB.:  $\mu$ PB. uPC.:  $\mu$ PC. uPD.:  $\mu$ PD.
- CAPACITORS  
uF:  $\mu$ F
- COILS  
uH:  $\mu$ H

When indicating parts by reference number, please include the board.

The components identified by mark  $\Delta$  or dotted line with mark  $\Delta$  are critical for safety. Replace only with part number specified.

Les composants identifiés par une marque  $\Delta$  sont critiques pour la sécurité. Ne les remplacer que par une pièce portant le numéro spécifié.

● Abbreviation CND: Canadian G: German

Ref. No.	Part No.	Description	Remark
*	A-2006-898-A	AUDIO BOARD, COMPLETE (US, AEP, G, E)	
*	A-2006-997-A	AUDIO BOARD, COMPLETE (CND)	
		*****	
		DOLBY S BOARD	
		*****	
	7-682-147-15	SCREW, TR	
		< CAPACITOR >	
C1	1-164-222-11	CERAMIC CHIP 0.22uF	25V
C2	1-135-177-21	TANTALUM CHIP 1uF	20% 20V
C3	1-137-301-11	FILM CHIP 0.039uF	5% 16V
C4	1-163-007-11	CERAMIC CHIP 680PF	10% 50V
C5	1-163-009-11	CERAMIC CHIP 0.001uF	10% 50V
C6	1-164-717-11	CERAMIC CHIP 0.0082uF	5% 50V
C7	1-164-222-11	CERAMIC CHIP 0.22uF	25V
C8	1-104-562-11	FILM CHIP 0.082uF	5% 16V
C9	1-104-553-11	FILM CHIP 0.015uF	5% 16V
C10	1-165-319-11	CERAMIC CHIP 0.1uF	50V
C11	1-135-145-11	TANTALUM CHIP 0.47uF	10% 35V
C12	1-164-222-11	CERAMIC CHIP 0.22uF	25V
C13	1-165-319-11	CERAMIC CHIP 0.1uF	50V
C14	1-162-568-11	CERAMIC CHIP 0.33uF	10% 16V
C15	1-104-562-11	FILM CHIP 0.082uF	5% 16V
C16	1-135-145-11	TANTALUM CHIP 0.47uF	10% 35V
C17	1-165-319-11	CERAMIC CHIP 0.1uF	50V
C18	1-164-222-11	CERAMIC CHIP 0.22uF	25V
C19	1-163-035-00	CERAMIC CHIP 0.047uF	50V
C20	1-104-553-11	FILM CHIP 0.015uF	5% 16V
C21	1-164-717-11	CERAMIC CHIP 0.0082uF	5% 50V
C22	1-163-009-11	CERAMIC CHIP 0.001uF	10% 50V
C23	1-164-161-11	CERAMIC CHIP 0.0022uF	10% 100V
C24	1-163-005-11	CERAMIC CHIP 470PF	10% 50V
C25	1-163-012-00	CERAMIC CHIP 0.0018uF	10% 50V
C26	1-137-301-11	FILM CHIP 0.039uF	5% 16V
C27	1-163-012-00	CERAMIC CHIP 0.0018uF	10% 50V
C28	1-163-012-00	CERAMIC CHIP 0.0018uF	10% 50V
C29	1-137-306-11	FILM CHIP 0.1uF	5% 16V
C30	1-135-145-11	TANTALUM CHIP 0.47uF	10% 35V

Ref. No.	Part No.	Description	Remark
C31	1-104-555-11	FILM CHIP 0.022uF	5% 16V
C32	1-104-563-11	FILM CHIP 0.1uF	5% 16V
C33	1-163-024-00	CERAMIC CHIP 0.018uF	10% 50V
C34	1-137-306-11	FILM CHIP 0.1uF	5% 16V
C35	1-163-012-00	CERAMIC CHIP 0.0018uF	10% 50V
C36	1-165-319-11	CERAMIC CHIP 0.1uF	50V
C37	1-164-222-11	CERAMIC CHIP 0.22uF	25V
C38	1-163-024-00	CERAMIC CHIP 0.018uF	10% 50V
C39	1-104-555-11	FILM CHIP 0.022uF	5% 16V
C40	1-137-306-11	FILM CHIP 0.1uF	5% 16V
C101	1-130-893-00	FILM 0.027uF	5% 100V
C102	1-124-916-11	ELECT 22uF	20% 63V
C103	1-124-916-11	ELECT 22uF	20% 63V
C104	1-130-893-00	FILM 0.027uF	5% 100V
C105	1-136-593-11	FILM 0.0033uF	5% 100V
C106	1-107-161-00	MICA 39PF	5% 500V
C107	1-136-250-11	FILM 0.001uF	5% 100V
C108	1-130-475-00	MYLAR 0.0022uF	5% 50V
C109	1-130-475-00	MYLAR 0.0022uF	5% 50V
C110	1-130-478-00	MYLAR 0.0039uF	5% 50V
C111	1-136-173-00	FILM 0.47uF	5% 50V
C112	1-136-167-00	FILM 0.15uF	5% 50V
C113	1-136-155-00	FILM 0.015uF	5% 50V
C114	1-124-903-11	ELECT 1uF	20% 50V
C115	1-136-169-00	FILM 0.22uF	5% 50V
C116	1-136-163-00	FILM 0.068uF	5% 50V
C117	1-136-162-00	FILM 0.056uF	5% 50V
C118	1-124-903-11	ELECT 1uF	20% 50V
C119	1-130-480-00	MYLAR 0.0056uF	5% 50V
C120	1-136-153-00	FILM 0.01uF	5% 50V
C121	1-124-916-11	ELECT 22uF	20% 63V
C122	1-124-916-11	ELECT 22uF	20% 63V
C123	1-124-916-11	ELECT 22uF	20% 63V
C124	1-126-059-11	ELECT 10uF	20% 50V
C125	1-124-916-11	ELECT 22uF	20% 63V
C126	1-124-916-11	ELECT 22uF	20% 63V
C127	1-123-382-00	ELECT 3.3uF	20% 100V
C129	1-124-925-11	ELECT 2.2uF	20% 100V
C130	1-130-475-00	MYLAR 0.0022uF	5% 50V
C132	1-126-059-11	ELECT 10uF	20% 50V

AUDIO

DOLBY S

Ref. No.	Part No.	Description	Remark			Ref. No.	Part No.	Description	Remark		
C133	1-123-369-00	ELECT	4.7uF	20%	50V	C205	1-136-593-11	FILM	0.0033uF	5%	100V
C134	1-123-369-00	ELECT	4.7uF	20%	50V	C206	1-107-161-00	MICA	39PF	5%	500V
C135	1-123-369-00	ELECT	4.7uF	20%	50V	C207	1-136-250-11	FILM	0.001uF	5%	100V
C136	1-107-159-00	MICA	33PF	5%	500V	C208	1-130-475-00	MYLAR	0.0022uF	5%	50V
C137	1-130-475-00	MYLAR	0.0022uF	5%	50V	C209	1-130-475-00	MYLAR	0.0022uF	5%	50V
C138	1-130-475-00	MYLAR	0.0022uF	5%	50V	C210	1-130-478-00	MYLAR	0.0039uF	5%	50V
C139	1-130-478-00	MYLAR	0.0039uF	5%	50V	C211	1-136-173-00	FILM	0.47uF	5%	50V
C140	1-136-173-00	FILM	0.47uF	5%	50V	C212	1-136-167-00	FILM	0.15uF	5%	50V
C141	1-136-167-00	FILM	0.15uF	5%	50V	C213	1-136-155-00	FILM	0.015uF	5%	50V
C142	1-136-155-00	FILM	0.015uF	5%	50V	C214	1-124-903-11	ELECT	1uF	20%	50V
C143	1-124-903-11	ELECT	1uF	20%	50V	C215	1-136-169-00	FILM	0.22uF	5%	50V
C144	1-136-169-00	FILM	0.22uF	5%	50V	C216	1-136-163-00	FILM	0.068uF	5%	50V
C145	1-136-163-00	FILM	0.068uF	5%	50V	C217	1-136-162-00	FILM	0.056uF	5%	50V
C146	1-136-162-00	FILM	0.056uF	5%	50V	C218	1-124-903-11	ELECT	1uF	20%	50V
C147	1-124-903-11	ELECT	1uF	20%	50V	C219	1-130-480-00	MYLAR	0.0056uF	5%	50V
C148	1-130-480-00	MYLAR	0.0056uF	5%	50V	C220	1-136-153-00	FILM	0.01uF	5%	50V
C149	1-136-153-00	FILM	0.01uF	5%	50V	C221	1-124-916-11	ELECT	22uF	20%	63V
C150	1-126-059-11	ELECT	10uF	20%	50V	C222	1-124-916-11	ELECT	22uF	20%	63V
C151	1-126-059-11	ELECT	10uF	20%	50V	C223	1-124-916-11	ELECT	22uF	20%	63V
C152	1-124-916-11	ELECT	22uF	20%	63V	C224	1-126-059-11	ELECT	10uF	20%	50V
C153	1-126-059-11	ELECT	10uF	20%	50V	C225	1-124-916-11	ELECT	22uF	20%	63V
C154	1-124-916-11	ELECT	22uF	20%	63V	C226	1-124-916-11	ELECT	22uF	20%	63V
C155	1-124-916-11	ELECT	22uF	20%	63V	C227	1-123-382-00	ELECT	3.3uF	20%	100V
C156	1-106-347-00	MYLAR	1500PF	5%	200V	C229	1-136-165-00	FILM	0.1uF	5%	50V
C157	1-106-343-00	MYLAR	1000PF	5%	200V	C232	1-126-059-11	ELECT	10uF	20%	50V
C158	1-106-347-00	MYLAR	1500PF	5%	200V	C233	1-123-369-00	ELECT	4.7uF	20%	50V
C159	1-126-059-11	ELECT	10uF	20%	50V	C234	1-123-369-00	ELECT	4.7uF	20%	50V
C160	1-130-493-00	MYLAR	0.068uF	5%	50V	C235	1-123-369-00	ELECT	4.7uF	20%	50V
C161	1-130-485-00	MYLAR	0.015uF	5%	50V	C236	1-107-159-00	MICA	33PF	5%	500V
C162	1-130-487-00	MYLAR	0.022uF	5%	50V	C237	1-130-475-00	MYLAR	0.0022uF	5%	50V
C163	1-130-485-00	MYLAR	0.015uF	5%	50V	C238	1-130-475-00	MYLAR	0.0022uF	5%	50V
C164	1-130-490-11	MYLAR	0.039uF	5%	50V	C239	1-130-478-00	MYLAR	0.0039uF	5%	50V
C165	1-130-486-00	MYLAR	0.018uF	10%	50V	C240	1-136-173-00	FILM	0.47uF	5%	50V
C166	1-124-916-11	ELECT	22uF	20%	63V	C241	1-136-167-00	FILM	0.15uF	5%	50V
C167	1-136-252-00	FILM	0.0015uF	5%	100V	C242	1-136-155-00	FILM	0.015uF	5%	50V
C168	1-107-210-00	MICA	22PF	5%	500V	C243	1-124-903-11	ELECT	1uF	20%	50V
C169	1-136-157-00	FILM	0.022uF	5%	50V	C244	1-136-169-00	FILM	0.22uF	5%	50V
C170	1-136-161-00	FILM	0.047uF	5%	50V	C245	1-136-163-00	FILM	0.068uF	5%	50V
C171	1-110-341-11	MYLAR	330PF	5%	50V	C246	1-136-162-00	FILM	0.056uF	5%	50V
C172	1-136-803-11	FILM	560PF	5%	630V	C247	1-124-903-11	ELECT	1uF	20%	50V
C173	1-107-169-00	MICA	100PF	5%	500V	C248	1-130-480-00	MYLAR	0.0056uF	5%	50V
C174	1-136-153-00	FILM	0.01uF	5%	50V	C249	1-136-153-00	FILM	0.01uF	5%	50V
C175	1-162-211-31	CERAMIC	33PF	5%	50V	C250	1-126-059-11	ELECT	10uF	20%	50V
C176	1-124-925-11	ELECT	2.2uF	20%	100V	C251	1-126-059-11	ELECT	10uF	20%	50V
C178	1-126-059-11	ELECT	10uF	20%	50V	C252	1-124-916-11	ELECT	22uF	20%	63V
C201	1-130-893-00	FILM	0.027uF	5%	100V	C253	1-126-059-11	ELECT	10uF	20%	50V
C202	1-124-916-11	ELECT	22uF	20%	63V	C254	1-124-916-11	ELECT	22uF	20%	63V
C203	1-124-916-11	ELECT	22uF	20%	63V	C255	1-124-916-11	ELECT	22uF	20%	63V
C204	1-130-893-00	FILM	0.027uF	5%	100V						

# AUDIO

# DOLBY S

Ref. No.	Part No.	Description	Value	Remark
C256	1-106-347-00	MYLAR	1500PF	5% 200V
C257	1-106-343-00	MYLAR	1000PF	5% 200V
C258	1-106-347-00	MYLAR	1500PF	5% 200V
C259	1-126-059-11	ELECT	10uF	20% 50V
C260	1-130-493-00	MYLAR	0.068uF	5% 50V
C261	1-130-485-00	MYLAR	0.015uF	5% 50V
C262	1-130-487-00	MYLAR	0.022uF	5% 50V
C263	1-130-485-00	MYLAR	0.015uF	5% 50V
C264	1-130-490-11	MYLAR	0.039uF	5% 50V
C265	1-130-486-00	MYLAR	0.018uF	10% 50V
C266	1-124-916-11	ELECT	22uF	20% 63V
C267	1-136-252-00	FILM	0.0015uF	5% 100V
C268	1-107-210-00	MICA	22PF	5% 500V
C269	1-136-157-00	FILM	0.022uF	5% 50V
C270	1-136-161-00	FILM	0.047uF	5% 50V
C271	1-110-341-11	MYLAR	330PF	5% 50V
C272	1-136-803-11	FILM	560PF	5% 630V
C273	1-107-169-00	MICA	100PF	5% 500V
C274	1-136-153-00	FILM	0.01uF	5% 50V
C275	1-162-211-31	CERAMIC	33PF	5% 50V
C276	1-124-925-11	ELECT	2.2uF	20% 100V
C278	1-126-059-11	ELECT	10uF	20% 50V
C501	1-126-066-11	ELECT	470uF	20% 63V
C502	1-126-066-11	ELECT	470uF	20% 63V
C503	1-107-159-00	MICA	33PF	5% 500V
C504	1-107-159-00	MICA	33PF	5% 500V
C505	1-124-122-11	ELECT	100uF	20% 50V
C506	1-136-153-00	FILM	0.01uF	5% 50V
C507	1-136-153-00	FILM	0.01uF	5% 50V
C508	1-124-922-11	ELECT	1000uF	20% 63V
C509	1-124-922-11	ELECT	1000uF	20% 63V
C510	1-126-059-11	ELECT	10uF	20% 50V
C511	1-126-059-11	ELECT	10uF	20% 50V
C513	1-123-369-00	ELECT	4.7uF	20% 50V
C514	1-123-369-00	ELECT	4.7uF	20% 50V
C515	1-164-159-11	CERAMIC	0.1uF	50V
C516	1-124-902-00	ELECT	0.47uF	20% 50V
C517	1-124-477-11	ELECT	47uF	20% 25V
C518	1-130-474-00	MYLAR	0.0018uF	5% 50V
C519	1-130-474-00	MYLAR	0.0018uF	5% 50V
C520	1-136-157-00	FILM	0.022uF	5% 50V
C521	1-136-157-00	FILM	0.022uF	5% 50V
C522	1-123-369-00	ELECT	4.7uF	20% 50V
C523	1-123-369-00	ELECT	4.7uF	20% 50V
C526	1-126-059-11	ELECT	10uF	20% 50V
C527	1-126-059-11	ELECT	10uF	20% 50V
C528	1-126-059-11	ELECT	10uF	20% 50V
C529	1-126-059-11	ELECT	10uF	20% 50V

Ref. No.	Part No.	Description	Value	Remark
C530	1-123-369-00	ELECT	4.7uF	20% 50V
C531	1-123-369-00	ELECT	4.7uF	20% 50V
C532	1-124-925-11	ELECT	2.2uF	20% 100V
C533	1-126-059-11	ELECT	10uF	20% 50V
C534	1-124-477-11	ELECT	47uF	20% 25V
C535	1-136-161-00	FILM	0.047uF	5% 50V
C536	1-124-907-11	ELECT	10uF	20% 50V
C537	1-124-925-11	ELECT	2.2uF	20% 100V
C538	1-162-282-31	CERAMIC	100PF	10% 50V
C539	1-136-228-11	FILM	0.0012uF	5% 100V
C540	1-136-228-11	FILM	0.0012uF	5% 100V
C541	1-136-233-11	FILM	0.0047uF	5% 100V
C542	1-124-907-11	ELECT	10uF	20% 50V
C543	1-136-559-11	FILM	0.0047uF	5% 630V
C544	1-107-045-00	MICA	3.9PF	500V

< CONNECTOR >

* CN1	1-537-473-11	TERMINAL (LEAD PIN)
* CN501	1-564-506-11	PLUG, CONNECTOR 3P
* CN502	1-560-062-00	PIN, CONNECTOR 4P
* CN503	1-564-508-11	PLUG, CONNECTOR 5P
* CN504	1-564-519-11	PLUG, CONNECTOR 4P
* CN505	1-564-523-11	PLUG, CONNECTOR 8P
* CN506	1-564-507-31	PLUG, CONNECTOR 4P
* CN507	1-564-509-11	PLUG, CONNECTOR 6P
* CN508	1-560-062-00	PIN, CONNECTOR 4P
* CN509	1-560-061-00	PIN, CONNECTOR 3P
* CN510	1-564-337-51	PIN, CONNECTOR 3P
* CN511	1-506-503-61	PIN, CONNECTOR 9P
* CN512	1-506-503-11	PIN, CONNECTOR 9P

< COMPOSITION CIRCUIT BLOCK >

CP103	1-236-087-11	FILTER, LOW PASS
CP203	1-236-087-11	FILTER, LOW PASS

< DIODE >

D101	8-719-987-63	DIODE	1N4148M
D102	8-719-987-63	DIODE	1N4148M
D103	8-719-987-63	DIODE	1N4148M
D104	8-719-987-63	DIODE	1N4148M
D105	8-719-987-63	DIODE	1N4148M
D106	8-719-987-63	DIODE	1N4148M
D107	8-719-000-54	DIODE	UZL-6L3
D108	8-719-987-63	DIODE	1N4148M
D109	8-719-987-63	DIODE	1N4148M
D201	8-719-987-63	DIODE	1N4148M
D202	8-719-987-63	DIODE	1N4148M
D203	8-719-987-63	DIODE	1N4148M
D204	8-719-987-63	DIODE	1N4148M

**AUDIO**      **DOLBY S**

Ref. No.	Part No.	Description	Remark
D205	8-719-987-63	DIODE 1N4148M	
D206	8-719-987-63	DIODE 1N4148M	
D207	8-719-000-54	DIODE UZL-6L3	
D208	8-719-987-63	DIODE 1N4148M	
D209	8-719-987-63	DIODE 1N4148M	
D501	8-719-933-41	DIODE HZS6C3L	
D503	8-719-987-63	DIODE 1N4148M	
D504	8-719-987-63	DIODE 1N4148M	
D505	8-719-987-63	DIODE 1N4148M	
D506	8-719-987-63	DIODE 1N4148M	
D507	8-719-987-63	DIODE 1N4148M	
D508	8-719-987-63	DIODE 1N4148M	
D509	8-719-987-63	DIODE 1N4148M	
D510	8-719-987-63	DIODE 1N4148M	
D511	8-719-987-63	DIODE 1N4148M	
D512	8-719-987-63	DIODE 1N4148M	
D513	8-719-987-63	DIODE 1N4148M	
D514	8-719-987-63	DIODE 1N4148M	
D515	8-719-987-63	DIODE 1N4148M	
D516	8-719-987-63	DIODE 1N4148M	
D517	8-719-987-63	DIODE 1N4148M	
D518	8-719-987-63	DIODE 1N4148M	
D519	8-719-987-63	DIODE 1N4148M	
D520	8-719-987-63	DIODE 1N4148M	
D521	8-719-987-63	DIODE 1N4148M	
D522	8-719-987-63	DIODE 1N4148M	
D523	8-719-987-63	DIODE 1N4148M	
D524	8-719-987-63	DIODE 1N4148M	
D525	8-719-987-63	DIODE 1N4148M	
D526	8-719-987-63	DIODE 1N4148M	
< IC >			
IC1	8-752-056-51	IC CXA1417Q	
IC2	8-759-711-85	IC NJM4580E-D	
IC501	8-759-602-01	IC M5220P	
IC502	8-752-018-80	IC CX20188	
IC503	8-759-710-59	IC NJM4580D-D	
IC506	8-759-145-58	IC uPC4558C	
IC507	8-759-634-50	IC M5218AL	
IC508	8-759-634-51	IC M5218AP	
IC509	8-759-145-58	IC uPC4558C	
IC510	8-759-710-59	IC NJM4580D-D	
IC511	8-752-018-80	IC CX20188	
IC513	8-759-710-59	IC NJM4580D-D	
IC514	8-759-106-56	IC uPC1297CA	
IC516	8-759-145-58	IC uPC4558C	
IC517	8-759-634-51	IC M5218AP	

Ref. No.	Part No.	Description	Remark
< JACK >			
J501	1-507-796-71	JACK (HEADPHONES)	
* J502	1-573-142-41	JACK, PIN 4P (LINE IN/OUT)	
< COIL >			
L101	1-408-927-11	INDUCTOR 18mH	
L102	1-408-920-00	INDUCTOR 4.7mH	
L103	1-408-918-11	INDUCTOR 3.3mH	
L104	1-408-916-11	INDUCTOR 2.2mH	
L105	1-408-929-00	INDUCTOR 27mH	
L106	1-410-769-31	INDUCTOR 3.3mH	
L201	1-408-927-11	INDUCTOR 18mH	
L202	1-408-920-00	INDUCTOR 4.7mH	
L203	1-408-918-11	INDUCTOR 3.3mH	
L204	1-408-916-11	INDUCTOR 2.2mH	
L205	1-408-929-00	INDUCTOR 27mH	
L206	1-410-769-31	INDUCTOR 3.3mH	
< PILOT LAMP >			
PL501	1-518-471-31	LAMP, PILOT	
PL502	1-518-471-31	LAMP, PILOT	
< IC LINK >			
△PS501	1-532-605-00	LINK, IC 0.4A	
△PS502	1-532-605-00	LINK, IC 0.4A	
△PS503	1-532-605-00	LINK, IC 0.4A	
△PS504	1-532-605-00	LINK, IC 0.4A	
< TRANSISTOR >			
Q101	8-729-922-37	TRANSISTOR 2SD2144S-UVW	
Q102	8-729-922-37	TRANSISTOR 2SD2144S-UVW	
Q103	8-729-203-06	TRANSISTOR 2SK30A-GR2	
Q104	8-729-203-06	TRANSISTOR 2SK30A-GR2	
Q105	8-729-203-06	TRANSISTOR 2SK30A-GR2	
Q106	8-729-203-06	TRANSISTOR 2SK30A-GR2	
Q107	8-729-922-37	TRANSISTOR 2SD2144S-UVW	
Q108	8-729-922-37	TRANSISTOR 2SD2144S-UVW	
Q109	8-729-922-37	TRANSISTOR 2SD2144S-UVW	
Q110	8-729-203-06	TRANSISTOR 2SK30A-GR2	
Q111	8-729-203-06	TRANSISTOR 2SK30A-GR2	
Q112	8-729-922-37	TRANSISTOR 2SD2144S-UVW	
Q113	8-729-922-37	TRANSISTOR 2SD2144S-UVW	
Q114	8-729-922-37	TRANSISTOR 2SD2144S-UVW	
Q115	8-729-922-37	TRANSISTOR 2SD2144S-UVW	
Q116	8-729-922-37	TRANSISTOR 2SD2144S-UVW	
Q117	8-729-900-80	TRANSISTOR DTC114ES	
Q201	8-729-922-37	TRANSISTOR 2SD2144S-UVW	
Q202	8-729-922-37	TRANSISTOR 2SD2144S-UVW	

<p>The components identified by mark △ or dotted line with mark. △ are critical for safety. Replace only with part number specified.</p>	<p>Les composants identifiés par une marque △ sont critiques pour la sécurité. Ne les remplacer que par une pièce portant le numéro spécifié.</p>
--	---

# AUDIO

# DOLBY S

Ref. No.	Part No.	Description	Remark
Q203	8-729-203-06	TRANSISTOR 2SK30A-GR2	
Q204	8-729-203-06	TRANSISTOR 2SK30A-GR2	
Q205	8-729-203-06	TRANSISTOR 2SK30A-GR2	
Q206	8-729-203-06	TRANSISTOR 2SK30A-GR2	
Q207	8-729-922-37	TRANSISTOR 2SD2144S-UVW	
Q208	8-729-922-37	TRANSISTOR 2SD2144S-UVW	
Q209	8-729-922-37	TRANSISTOR 2SD2144S-UVW	
Q210	8-729-203-06	TRANSISTOR 2SK30A-GR2	
Q211	8-729-203-06	TRANSISTOR 2SK30A-GR2	
Q212	8-729-922-37	TRANSISTOR 2SD2144S-UVW	
Q213	8-729-922-37	TRANSISTOR 2SD2144S-UVW	
Q214	8-729-922-37	TRANSISTOR 2SD2144S-UVW	
Q215	8-729-922-37	TRANSISTOR 2SD2144S-UVW	
Q216	8-729-922-37	TRANSISTOR 2SD2144S-UVW	
Q217	8-729-900-80	TRANSISTOR DTC114ES	
Q501	8-729-107-53	TRANSISTOR 2SC2275A-P	
Q502	8-729-141-10	TRANSISTOR 2SA985A-QP	
Q503	8-729-224-62	TRANSISTOR 2SK246-GR	
Q504	8-729-224-62	TRANSISTOR 2SK246-GR	
Q505	8-729-366-62	TRANSISTOR 2SD666-C	
Q506	8-729-364-62	TRANSISTOR 2SB646-C	
Q507	8-729-366-62	TRANSISTOR 2SD666-C	
Q508	8-729-364-62	TRANSISTOR 2SB646-C	
Q509	8-729-922-37	TRANSISTOR 2SD2144S-UVW	
Q510	8-729-922-37	TRANSISTOR 2SD2144S-UVW	
Q511	8-729-900-89	TRANSISTOR DTC144ES	
Q514	8-729-900-89	TRANSISTOR DTC144ES	
Q515	8-729-922-37	TRANSISTOR 2SD2144S-UVW	
Q516	8-729-922-37	TRANSISTOR 2SD2144S-UVW	
Q519	8-729-900-61	TRANSISTOR DTA114ES	
Q520	8-729-900-89	TRANSISTOR DTC144ES	
Q521	8-729-900-61	TRANSISTOR DTA114ES	
Q522	8-729-900-80	TRANSISTOR DTC114ES	
Q523	8-729-900-80	TRANSISTOR DTC114ES	
Q524	8-729-900-80	TRANSISTOR DTC114ES	
Q525	8-729-900-80	TRANSISTOR DTC114ES	
Q526	8-729-281-52	TRANSISTOR 2SC1815-Y	
Q527	8-729-194-57	TRANSISTOR 2SC945-P	
Q528	8-729-194-57	TRANSISTOR 2SC945-P	
< RESISTOR >			
R1	1-216-013-00	METAL CHIP 33 5% 1/10W	
R2	1-216-675-11	METAL CHIP 10K 0.5% 1/10W	
R3	1-216-681-11	METAL CHIP 18K 0.5% 1/10W	
R4	1-218-774-11	METAL CHIP 820K 0.50% 1/10W	
R5	1-216-668-11	METAL CHIP 5.1K 0.5% 1/10W	
R6	1-216-656-11	METAL CHIP 1.6K 0.5% 1/10W	
R7	1-216-657-11	METAL CHIP 1.8K 0.5% 1/10W	

Ref. No.	Part No.	Description	Remark
R8	1-216-065-00	METAL CHIP 4.7K 5% 1/10W	
R9	1-216-058-00	METAL GLAZE 2.4K 5% 1/10W	
R10	1-216-654-11	METAL CHIP 1.3K 0.5% 1/10W	
R11	1-216-013-00	METAL CHIP 33 5% 1/10W	
R12	1-216-017-00	METAL CHIP 47 5% 1/10W	
R13	1-216-051-00	METAL CHIP 1.2K 5% 1/10W	
R14	1-216-065-00	METAL CHIP 4.7K 5% 1/10W	
R15	1-216-058-00	METAL GLAZE 2.4K 5% 1/10W	
R16	1-216-013-00	METAL CHIP 33 5% 1/10W	
R17	1-216-017-00	METAL CHIP 47 5% 1/10W	
R18	1-216-055-00	METAL CHIP 1.8K 5% 1/10W	
R19	1-216-656-11	METAL CHIP 1.6K 0.5% 1/10W	
R20	1-216-668-11	METAL CHIP 5.1K 0.5% 1/10W	
R21	1-218-774-11	METAL CHIP 820K 0.50% 1/10W	
R22	1-216-655-11	METAL CHIP 1.5K 0.5% 1/10W	
R23	1-216-678-11	METAL CHIP 13K 0.5% 1/10W	
R24	1-216-673-11	METAL CHIP 8.2K 0.5% 1/10W	
R25	1-216-675-11	METAL CHIP 10K 0.5% 1/10W	
R26	1-216-676-11	METAL CHIP 11K 0.5% 1/10W	
R27	1-216-668-11	METAL CHIP 5.1K 0.5% 1/10W	
R28	1-216-697-11	METAL CHIP 82K 0.5% 1/10W	
R29	1-216-668-11	METAL CHIP 5.1K 0.5% 1/10W	
R30	1-216-660-11	METAL CHIP 2.4K 0.5% 1/10W	
R31	1-216-680-11	METAL CHIP 16K 0.5% 1/10W	
R32	1-216-685-11	METAL CHIP 27K 0.5% 1/10W	
R33	1-216-080-00	METAL CHIP 20K 5% 1/10W	
R34	1-216-684-11	METAL CHIP 24K 0.5% 1/10W	
R35	1-216-084-00	METAL CHIP 30K 5% 1/10W	
R36	1-216-084-00	METAL CHIP 30K 5% 1/10W	
R37	1-216-074-00	METAL CHIP 11K 5% 1/10W	
R38	1-216-086-00	METAL GLAZE 36K 5% 1/10W	
R39	1-216-066-00	METAL CHIP 5.1K 5% 1/10W	
R40	1-216-084-00	METAL CHIP 30K 5% 1/10W	
R41	1-216-078-00	METAL GLAZE 16K 5% 1/10W	
R42	1-216-071-00	METAL CHIP 8.2K 5% 1/10W	
R43	1-216-081-00	METAL CHIP 22K 5% 1/10W	
R44	1-216-689-11	METAL CHIP 39K 0.5% 1/10W	
R45	1-216-689-11	METAL CHIP 39K 0.5% 1/10W	
R51	1-216-669-11	METAL CHIP 5.6K 0.5% 1/10W	
R52	1-216-663-11	METAL CHIP 3.3K 0.5% 1/10W	
R55	1-216-658-11	METAL CHIP 2K 0.5% 1/10W	
R101	1-249-466-11	CARBON 56K 5% 1/4W	
R102	1-249-531-11	CARBON 130 5% 1/4W	
R103	1-247-146-00	CARBON 4.3K 5% 1/4W	
R104	1-249-602-11	CARBON 120K 5% 1/4W	
R105	1-249-465-11	CARBON 47K 5% 1/4W	
R106	1-247-717-11	CARBON 2.2K 5% 1/4W	
R107	1-247-138-00	CARBON 2K 5% 1/4W	



AUDIO

DOLBY S

Ref. No.	Part No.	Description	Remark		
R108	1-249-429-11	CARBON	10K	5%	1/4W
R109	1-247-717-11	CARBON	2.2K	5%	1/4W
R110	1-249-465-11	CARBON	47K	5%	1/4W
R111	1-247-710-11	CARBON	560	5%	1/4W
R112	1-247-725-11	CARBON	10K	5%	1/4W
R113	1-247-719-11	CARBON	3.3K	5%	1/4W
R114	1-247-719-11	CARBON	3.3K	5%	1/4W
R115	1-259-500-11	CARBON	1M	5%	1/6W
R116	1-247-710-11	CARBON	560	5%	1/4W
R117	1-249-462-11	CARBON	22K	5%	1/4W
R118	1-259-449-11	CARBON	7.5K	5%	1/6W
R119	1-259-424-11	CARBON	680	5%	1/6W
R120	1-259-451-11	CARBON	9.1K	5%	1/6W
R121	1-249-429-11	CARBON	10K	5%	1/4W
R122	1-249-940-11	CARBON	5.1K	1%	1/4W
R123	1-247-721-11	CARBON	4.7K	5%	1/4W
R124	1-249-949-11	CARBON	12K	1%	1/4W
R125	1-247-715-11	CARBON	1.5K	5%	1/4W
R126	1-247-715-11	CARBON	1.5K	5%	1/4W
R127	1-249-913-11	CARBON	390	1%	1/4W
R128	1-249-465-11	CARBON	47K	5%	1/4W
R129	1-247-716-11	CARBON	1.8K	5%	1/4W
R130	1-249-421-11	CARBON	2.2K	5%	1/4W
R131	1-249-465-11	CARBON	47K	5%	1/4W
R132	1-247-725-11	CARBON	10K	5%	1/4W
R133	1-215-441-00	METAL	6.8K	1%	1/6W
R134	1-215-465-00	METAL	68K	1%	1/6W
R135	1-215-448-00	METAL	13K	1%	1/6W
R136	1-215-471-00	METAL	120K	1%	1/6W
R137	1-215-403-00	METAL	180	1%	1/6W
R138	1-215-473-00	METAL	150K	1%	1/6W
R139	1-249-465-11	CARBON	47K	5%	1/4W
R140	1-249-433-11	CARBON	22K	5%	1/4W
R141	1-249-417-11	CARBON	1K	5%	1/4W
R142	1-249-437-11	CARBON	47K	5%	1/4W
R143	1-249-427-11	CARBON	6.8K	5%	1/4W
R144	1-247-725-11	CARBON	10K	5%	1/4W
R145	1-247-719-11	CARBON	3.3K	5%	1/4W
R146	1-249-462-11	CARBON	22K	5%	1/4W
R147	1-247-704-11	CARBON	220	5%	1/4W
R148	1-247-713-11	CARBON	1K	5%	1/4W
R149	1-249-461-11	CARBON	18K	5%	1/4W
R150	1-249-469-11	CARBON	100K	5%	1/4W
R151	1-247-723-11	CARBON	6.8K	5%	1/4W
R152	1-247-720-11	CARBON	3.9K	5%	1/4W
R153	1-247-152-00	CARBON	7.5K	5%	1/4W
R154	1-249-465-11	CARBON	47K	5%	1/4W
R155	1-249-465-11	CARBON	47K	5%	1/4W
R156	1-247-128-00	CARBON	750	5%	1/4W

Ref. No.	Part No.	Description	Remark		
R157	1-247-725-11	CARBON	10K	5%	1/4W
R158	1-247-719-11	CARBON	3.3K	5%	1/4W
R159	1-247-719-11	CARBON	3.3K	5%	1/4W
R160	1-259-500-11	CARBON	1M	5%	1/6W
R161	1-247-710-11	CARBON	560	5%	1/4W
R162	1-249-462-11	CARBON	22K	5%	1/4W
R163	1-259-449-11	CARBON	7.5K	5%	1/6W
R164	1-259-424-11	CARBON	680	5%	1/6W
R165	1-259-451-11	CARBON	9.1K	5%	1/6W
R166	1-249-469-11	CARBON	100K	5%	1/4W
R167	1-249-429-11	CARBON	10K	5%	1/4W
R168	1-247-193-00	CARBON	22K	1%	1/4W
R169	1-247-193-00	CARBON	22K	1%	1/4W
R170	1-247-719-11	CARBON	3.3K	5%	1/4W
R171	1-249-941-11	CARBON	5.6K	1%	1/4W
R172	1-249-469-11	CARBON	100K	5%	1/4W
R173	1-247-721-11	CARBON	4.7K	5%	1/4W
R174	1-247-152-00	CARBON	8.2K	5%	1/4W
R175	1-247-725-11	CARBON	10K	5%	1/4W
R176	1-247-721-11	CARBON	4.7K	5%	1/4W
R177	1-259-500-11	CARBON	1M	5%	1/6W
R178	1-249-462-11	CARBON	22K	5%	1/4W
R179	1-247-719-11	CARBON	3.3K	5%	1/4W
R180	1-247-723-11	CARBON	6.8K	5%	1/4W
R181	1-249-421-11	CARBON	2.2K	5%	1/4W
R182	1-249-590-11	CARBON	39K	5%	1/4W
R183	1-249-429-11	CARBON	10K	5%	1/4W
R184	1-249-465-11	CARBON	47K	5%	1/4W
R185	1-249-556-11	CARBON	1.5K	5%	1/4W
R186	1-249-598-11	CARBON	82K	5%	1/4W
R187	1-249-962-11	CARBON	43K	1%	1/4W
R188	1-247-702-11	CARBON	150	5%	1/4W
R190	1-247-702-11	CARBON	150	5%	1/4W
R191	1-247-723-11	CARBON	6.8K	5%	1/4W
R192	1-247-721-11	CARBON	4.7K	5%	1/4W
R193	1-247-700-11	CARBON	100	5%	1/4W
R194	1-247-723-11	CARBON	6.8K	5%	1/4W
R195	1-247-721-11	CARBON	4.7K	5%	1/4W
R196	1-249-429-11	CARBON	10K	5%	1/4W
R197	1-249-429-11	CARBON	10K	5%	1/4W
R198	1-249-429-11	CARBON	10K	5%	1/4W
R199	1-247-718-11	CARBON	2.7K	5%	1/4W
R201	1-249-466-11	CARBON	56K	5%	1/4W
R202	1-249-531-11	CARBON	130	5%	1/4W
R203	1-247-146-00	CARBON	4.3K	5%	1/4W
R204	1-249-602-11	CARBON	120K	5%	1/4W
R205	1-249-465-11	CARBON	47K	5%	1/4W
R206	1-247-717-11	CARBON	2.2K	5%	1/4W

AUDIO

DOLBY S

Ref. No.	Part No.	Description	Remark		
R207	1-247-138-00	CARBON	2K	5%	1/4W
R208	1-249-429-11	CARBON	10K	5%	1/4W
R209	1-247-717-11	CARBON	2.2K	5%	1/4W
R210	1-249-465-11	CARBON	47K	5%	1/4W
R211	1-247-710-11	CARBON	560	5%	1/4W
R212	1-247-725-11	CARBON	10K	5%	1/4W
R213	1-247-719-11	CARBON	3.3K	5%	1/4W
R214	1-247-719-11	CARBON	3.3K	5%	1/4W
R215	1-259-500-11	CARBON	1M	5%	1/6W
R216	1-247-710-11	CARBON	560	5%	1/4W
R217	1-249-462-11	CARBON	22K	5%	1/4W
R218	1-259-449-11	CARBON	7.5K	5%	1/6W
R219	1-259-424-11	CARBON	680	5%	1/6W
R220	1-259-451-11	CARBON	9.1K	5%	1/6W
R221	1-249-429-11	CARBON	10K	5%	1/4W
R222	1-249-940-11	CARBON	5.1K	1%	1/4W
R223	1-247-721-11	CARBON	4.7K	5%	1/4W
R224	1-249-949-11	CARBON	12K	1%	1/4W
R225	1-247-715-11	CARBON	1.5K	5%	1/4W
R226	1-247-715-11	CARBON	1.5K	5%	1/4W
R227	1-249-913-11	CARBON	390	1%	1/4W
R228	1-249-465-11	CARBON	47K	5%	1/4W
R229	1-247-716-11	CARBON	1.8K	5%	1/4W
R230	1-249-421-11	CARBON	2.2K	5%	1/4W
R231	1-249-465-11	CARBON	47K	5%	1/4W
R232	1-247-725-11	CARBON	10K	5%	1/4W
R233	1-215-441-00	METAL	6.8K	1%	1/6W
R234	1-215-465-00	METAL	68K	1%	1/6W
R235	1-215-448-00	METAL	13K	1%	1/6W
R236	1-215-471-00	METAL	120K	1%	1/6W
R237	1-215-403-00	METAL	180	1%	1/6W
R238	1-215-473-00	METAL	150K	1%	1/6W
R239	1-249-465-11	CARBON	47K	5%	1/4W
R240	1-249-433-11	CARBON	22K	5%	1/4W
R241	1-249-417-11	CARBON	1K	5%	1/4W
R242	1-249-437-11	CARBON	47K	5%	1/4W
R243	1-249-427-11	CARBON	6.8K	5%	1/4W
R244	1-247-725-11	CARBON	10K	5%	1/4W
R245	1-247-719-11	CARBON	3.3K	5%	1/4W
R246	1-249-462-11	CARBON	22K	5%	1/4W
R247	1-247-704-11	CARBON	220	5%	1/4W
R248	1-247-713-11	CARBON	1K	5%	1/4W
R249	1-249-461-11	CARBON	18K	5%	1/4W
R250	1-249-469-11	CARBON	100K	5%	1/4W
R251	1-247-723-11	CARBON	6.8K	5%	1/4W
R252	1-247-720-11	CARBON	3.9K	5%	1/4W
R253	1-247-152-00	CARBON	7.5K	5%	1/4W
R254	1-249-465-11	CARBON	47K	5%	1/4W
R255	1-249-465-11	CARBON	47K	5%	1/4W
R256	1-247-128-00	CARBON	750	5%	1/4W
R257	1-247-725-11	CARBON	10K	5%	1/4W
R258	1-247-719-11	CARBON	3.3K	5%	1/4W
R259	1-247-719-11	CARBON	3.3K	5%	1/4W
R260	1-259-500-11	CARBON	1M	5%	1/6W
R261	1-247-710-11	CARBON	560	5%	1/4W
R262	1-249-462-11	CARBON	22K	5%	1/4W
R263	1-259-449-11	CARBON	7.5K	5%	1/6W
R264	1-259-424-11	CARBON	680	5%	1/6W
R265	1-259-451-11	CARBON	9.1K	5%	1/6W
R266	1-249-469-11	CARBON	100K	5%	1/4W
R267	1-249-429-11	CARBON	10K	5%	1/4W
R268	1-247-193-00	CARBON	22K	1%	1/4W
R269	1-247-193-00	CARBON	22K	1%	1/4W
R270	1-247-719-11	CARBON	3.3K	5%	1/4W
R271	1-249-941-11	CARBON	5.6K	1%	1/4W
R272	1-249-469-11	CARBON	100K	5%	1/4W
R273	1-247-721-11	CARBON	4.7K	5%	1/4W
R274	1-247-152-00	CARBON	8.2K	5%	1/4W
R275	1-247-725-11	CARBON	10K	5%	1/4W
R276	1-247-721-11	CARBON	4.7K	5%	1/4W
R277	1-259-500-11	CARBON	1M	5%	1/6W
R278	1-249-462-11	CARBON	22K	5%	1/4W
R279	1-247-719-11	CARBON	3.3K	5%	1/4W
R280	1-247-723-11	CARBON	6.8K	5%	1/4W
R281	1-249-421-11	CARBON	2.2K	5%	1/4W
R282	1-249-590-11	CARBON	39K	5%	1/4W
R283	1-249-429-11	CARBON	10K	5%	1/4W
R284	1-249-465-11	CARBON	47K	5%	1/4W
R285	1-249-556-11	CARBON	1.5K	5%	1/4W
R286	1-249-598-11	CARBON	82K	5%	1/4W
R287	1-249-962-11	CARBON	43K	1%	1/4W
R288	1-247-702-11	CARBON	150	5%	1/4W
R290	1-247-702-11	CARBON	150	5%	1/4W
R291	1-247-723-11	CARBON	6.8K	5%	1/4W
R292	1-247-721-11	CARBON	4.7K	5%	1/4W
R293	1-247-700-11	CARBON	100	5%	1/4W
R294	1-247-723-11	CARBON	6.8K	5%	1/4W
R295	1-247-721-11	CARBON	4.7K	5%	1/4W
R296	1-249-429-11	CARBON	10K	5%	1/4W
R297	1-249-429-11	CARBON	10K	5%	1/4W
R298	1-249-429-11	CARBON	10K	5%	1/4W
R299	1-247-718-11	CARBON	2.7K	5%	1/4W
R301	1-249-439-11	CARBON	68K	5%	1/4W
R302	1-249-426-11	CARBON	5.6K	5%	1/4W
R303	1-247-883-00	CARBON	150K	5%	1/4W
△R304	1-212-857-00	FUSIBLE	10	5%	1/4W F
R307	1-247-719-11	CARBON	3.3K	5%	1/4W

The components identified by mark  $\triangle$  or dotted line with mark  $\triangle$  are critical for safety. Replace only with part number specified.

Les composants identifiés par une marque  $\triangle$  sont critiques pour la sécurité. Ne les remplacer que par une pièce portant le numéro spécifié.

AUDIO

DOLBY S

Ref. No.	Part No.	Description	Remark		
R308	1-249-465-11	CARBON	47K	5%	1/4W
R309	1-249-962-11	CARBON	43K	1%	1/4W
R310	1-249-465-11	CARBON	47K	5%	1/4W
R401	1-249-439-11	CARBON	68K	5%	1/4W
R402	1-249-426-11	CARBON	5.6K	5%	1/4W
R403	1-247-883-00	CARBON	150K	5%	1/4W
△R404	1-212-857-00	FUSIBLE	10	5%	1/4W F
R407	1-247-719-11	CARBON	3.3K	5%	1/4W
R408	1-249-465-11	CARBON	47K	5%	1/4W
R409	1-249-962-11	CARBON	43K	1%	1/4W
R410	1-249-465-11	CARBON	47K	5%	1/4W
R501	1-247-704-11	CARBON	220	5%	1/4W
R502	1-247-704-11	CARBON	220	5%	1/4W
R503	1-247-717-11	CARBON	2.2K	5%	1/4W
R504	1-247-717-11	CARBON	2.2K	5%	1/4W
R505	1-247-717-11	CARBON	2.2K	5%	1/4W
R507	1-247-706-11	CARBON	330	5%	1/4W
R508	1-249-926-11	CARBON	1.3K	5%	1/4W
R509	1-249-556-11	CARBON	1.5K	5%	1/4W
R510	1-249-556-11	CARBON	1.5K	5%	1/4W
R511	1-249-433-11	CARBON	22K	5%	1/4W
R512	1-249-437-11	CARBON	47K	5%	1/4W
R513	1-249-433-11	CARBON	22K	5%	1/4W
R514	1-249-429-11	CARBON	10K	5%	1/4W
R515	1-215-472-00	METAL	130K	1%	1/6W
R516	1-249-429-11	CARBON	10K	5%	1/4W
R517	1-249-437-11	CARBON	47K	5%	1/4W
R518	1-249-417-11	CARBON	1K	5%	1/4W
R519	1-247-885-00	CARBON	180K	5%	1/4W
R520	1-249-433-11	CARBON	22K	5%	1/4W
R521	1-249-413-11	CARBON	470	5%	1/4W
R522	1-249-413-11	CARBON	470	5%	1/4W
R523	1-249-432-11	CARBON	18K	5%	1/4W
R524	1-249-433-11	CARBON	22K	5%	1/4W
R527	1-249-433-11	CARBON	22K	5%	1/4W
R528	1-249-421-11	CARBON	2.2K	5%	1/4W
R530	1-249-429-11	CARBON	10K	5%	1/4W
R531	1-249-433-11	CARBON	22K	5%	1/4W
R532	1-249-437-11	CARBON	47K	5%	1/4W
R533	1-247-856-00	CARBON	11K	5%	1/4W
R534	1-249-397-11	CARBON	22	5%	1/4W
R535	1-249-406-11	CARBON	120	5%	1/4W
R536	1-247-856-00	CARBON	11K	5%	1/4W
R537	1-249-437-11	CARBON	47K	5%	1/4W
R538	1-249-432-11	CARBON	18K	5%	1/4W
R539	1-249-397-11	CARBON	22	5%	1/4W
R540	1-249-406-11	CARBON	120	5%	1/4W
R541	1-249-432-11	CARBON	18K	5%	1/4W

Ref. No.	Part No.	Description	Remark		
R542	1-247-887-00	CARBON	220K	5%	1/4W
R543	1-247-887-00	CARBON	220K	5%	1/4W
R544	1-249-407-11	CARBON	150	5%	1/4W
R547	1-249-437-11	CARBON	47K	5%	1/4W
R548	1-249-429-11	CARBON	10K	5%	1/4W
R549	1-249-437-11	CARBON	47K	5%	1/4W
R550	1-249-437-11	CARBON	47K	5%	1/4W
R551	1-249-437-11	CARBON	47K	5%	1/4W
R552	1-249-421-11	CARBON	2.2K	5%	1/4W
R553	1-249-441-11	CARBON	100K	5%	1/4W
R554	1-249-414-11	CARBON	560	5%	1/4W
R555	1-247-830-11	CARBON	910	5%	1/4W
R556	1-249-425-11	CARBON	4.7K	5%	1/4W
R557	1-249-417-11	CARBON	1K	5%	1/4W
R558	1-249-421-11	CARBON	2.2K	5%	1/4W
R560	1-249-433-11	CARBON	22K	5%	1/4W
R561	1-249-427-11	CARBON	6.8K	5%	1/4W
R562	1-249-440-11	CARBON	82K	5%	1/4W
R563	1-249-440-11	CARBON	82K	5%	1/4W
△R564	1-212-853-00	FUSIBLE	6.8	5%	1/4W F
△R565	1-212-853-00	FUSIBLE	6.8	5%	1/4W F
R566	1-249-381-11	CARBON	1	5%	1/4W
R567	1-249-437-11	CARBON	47K	5%	1/4W
R568	1-215-472-00	METAL	130K	1%	1/6W
R569	1-249-429-11	CARBON	10K	5%	1/4W
R570	1-249-429-11	CARBON	10K	5%	1/4W
< VARIABLE RESISTOR >					
RV101	1-237-192-11	RES, ADJ, CARBON	5K		
RV102	1-241-631-11	RES, ADJ, CARBON	22K		
RV103	1-237-192-11	RES, ADJ, CARBON	5K		
RV104	1-241-631-11	RES, ADJ, CARBON	22K		
RV105	1-241-629-11	RES, ADJ, CARBON	4.7K		
RV201	1-237-192-11	RES, ADJ, CARBON	5K		
RV202	1-241-631-11	RES, ADJ, CARBON	22K		
RV203	1-237-192-11	RES, ADJ, CARBON	5K		
RV204	1-241-631-11	RES, ADJ, CARBON	22K		
RV205	1-241-629-11	RES, ADJ, CARBON	4.7K		
RV501	1-223-264-11	RES, VAR, CARBON	50K/50K		(BALANCE)
RV502	1-223-265-11	RES, VAR, CARBON	20K/20K		(REC LEVEL)
RV503	1-238-840-21	RES, VAR, CARBON	5K/5K		(REC LEVEL CAL)
RV504	1-241-336-11	RES, VAR, CARBON	20K/20K		(PHONE LEVEL)
RV505	1-238-019-11	RES, ADJ, CARBON	47K		
RV506	1-241-629-11	RES, ADJ, CARBON	4.7K		
RV507	1-238-009-11	RES, ADJ, CARBON	220		
RV508	1-238-009-11	RES, ADJ, CARBON	220		

The components identified by mark △ or dotted line with mark △ are critical for safety. Replace only with part number specified.

Les composants identifiés par une marque △ sont critiques pour la sécurité. Ne les remplacer que par une pièce portant le numéro spécifié.

**AUDIO**

**DOLBY S**

**CAPSTAN**

**COMPARATOR**

**MD**

Ref. No.	Part No.	Description	Remark
< SWITCH >			
S501	1-692-375-11	SWITCH, PUSH (1 KEY) (DIRECT)	
S502	1-572-589-11	SWITCH, ROTARY (REC EQ CAL)	
< TRANSFORMER >			
T101	1-433-379-11	TRANSFORMER, BIAS OSCILLATOR	
T201	1-433-379-11	TRANSFORMER, BIAS OSCILLATOR	
T501	1-433-359-11	TRANSFORMER, BIAS OSCILLATION	
< TERMINAL >			
* TB501	4-942-204-01	PLATE, GROUND	
< TEST PIN >			
* TP501	1-564-506-11	PLUG, CONNECTOR 3P	
* TP502	1-564-506-11	PLUG, CONNECTOR 3P	
* TP503	1-564-505-41	PLUG, CONNECTOR 2P	
*****			
A-2006-154-A CAPSTAN BOARD, COMPLETE			
*****			
< CAPACITOR >			
C905	1-124-779-00	ELECT CHIP 10uF	20% 16V
C906	1-135-091-00	TANTALUM CHIP 1uF	20% 16V
C907	1-163-077-00	CERAMIC CHIP 0.1uF	10% 25V
C908	1-163-077-00	CERAMIC CHIP 0.1uF	10% 25V
C909	1-163-077-00	CERAMIC CHIP 0.1uF	10% 25V
C910	1-163-205-00	CERAMIC CHIP 0.001uF	5% 50V
C911	1-124-779-00	ELECT CHIP 10uF	20% 16V
< HOLE ELEMENT >			
H901	8-719-403-79	DIODE OH009	
H902	8-719-403-79	DIODE OH009	
H903	8-719-403-79	DIODE OH009	
< IC >			
IC902	8-752-017-40	IC CX20174	
< RESISTOR >			
R907	1-216-242-00	METAL GLAZE 68K	5% 1/8W
R908	1-216-246-00	METAL GLAZE 100K	5% 1/8W
R909	1-216-246-00	METAL GLAZE 100K	5% 1/8W
R910	1-216-238-00	METAL GLAZE 47K	5% 1/8W
R911	1-216-182-00	METAL GLAZE 220	5% 1/8W
R912	1-216-182-00	METAL GLAZE 220	5% 1/8W
R913	1-216-150-00	METAL GLAZE 10	5% 1/8W
R914	1-216-150-00	METAL GLAZE 10	5% 1/8W
R915	1-216-150-00	METAL GLAZE 10	5% 1/8W

Ref. No.	Part No.	Description	Remark
*	1-632-746-11	COMPARATOR BOARD	*****
< CAPACITOR >			
C951	1-136-157-00	FILM 0.022uF	5% 50V
C952	1-124-282-00	ELECT 22uF	20% 25V
C953	1-124-478-11	ELECT 100uF	20% 25V
C954	1-124-477-11	ELECT 47uF	20% 25V
C955	1-162-203-31	CERAMIC 15PF	5% 50V
C956	1-162-203-31	CERAMIC 15PF	5% 50V
C957	1-136-159-00	FILM 0.033uF	5% 50V
< CONNECTOR >			
* CN951	1-564-718-11	PIN, CONNECTOR (SMALL TYPE) 2P	
* CN952	1-564-518-11	PLUG, CONNECTOR 3P	
< IC >			
IC951	8-759-145-58	IC uPC4558C	
IC952	8-759-201-58	IC TC9142P	
< RESISTOR >			
R951	1-249-413-11	CARBON 470	5% 1/4W
R952	1-249-413-11	CARBON 470	5% 1/4W
R953	1-247-881-00	CARBON 120K	5% 1/4W
R954	1-247-881-00	CARBON 120K	5% 1/4W
R955	1-249-429-11	CARBON 10K	5% 1/4W
R956	1-249-417-11	CARBON 1K	5% 1/4W
R957	1-249-417-11	CARBON 1K	5% 1/4W
R958	1-247-891-00	CARBON 330K	5% 1/4W
R959	1-247-901-11	CARBON 820K	5% 1/4W
R960	1-249-441-11	CARBON 100K	5% 1/4W
< VIBRATOR >			
X951	1-577-615-11	VIBRATOR, CRYSTAL 4.9046MHz	
*****			
*	1-632-740-11	MD BOARD	*****
3-356-631-01 HOLDER (SENSOR)			
< CONNECTOR >			
CN1001	1-506-615-11	PIN, CONNECTOR 9P	
CN1002	1-564-501-11	PIN, CONNECTOR 8P	
< IC >			
IC1001	8-749-920-97	DIODE GP2S22B	
IC1002	8-749-920-97	DIODE GP2S22B	

**MD**

**REEL MOTOR**

**SYSTEM CONTROL**

Ref. No.	Part No.	Description	Remark		
< RESISTOR >					
R1001	1-249-408-11	CARBON	180	5%	1/4W
R1002	1-249-408-11	CARBON	180	5%	1/4W
< SWITCH >					
S1002	1-570-953-11	SWITCH, PUSH (1 KEY) (DOOR)			
S1003	1-571-958-11	SWITCH, PUSH (1 KEY) (CLOSE)			
S1004	1-572-126-11	SWITCH, PUSH (1 KEY) (OPEN)			
S1005	1-572-125-11	SWITCH, LEAF (FWD TAB)			
S1006	1-572-202-11	SWITCH, LEAF (HALF)			
S1007	1-572-125-11	SWITCH, LEAF (METAL)			
S1008	1-572-125-11	SWITCH, LEAF (70u)			
< TERMINAL >					
* TB1001	1-694-018-11	TERMINAL (5P)			
*****					
* 1-632-741-11	REEL MOTOR BOARD				
*****					
< CAPACITOR >					
C1051	1-124-907-11	ELECT	10uF	20%	50V
C1052	1-124-907-11	ELECT	10uF	20%	50V
C1053	1-164-159-11	CERAMIC	0.1uF		50V
< CONNECTOR >					
* CN1051	1-564-499-11	PIN, CONNECTOR 6P			
* CN1052	1-564-718-11	PIN, CONNECTOR (SMALL TYPE) 2P			
* CN1053	1-564-718-11	PIN, CONNECTOR (SMALL TYPE) 2P			
< RESISTOR >					
R1051	1-249-412-11	CARBON	390	5%	1/4W
*****					
* A-2006-998-A	SYSTEM CONTROL BOARD, COMPLETE				
*****					
* 1-533-213-11	HOLDER, FUSE				
* 1-533-213-31	HOLDER, FUSE				
* 3-309-144-31	HEAT SINK				
* 9-911-844-XX	CUSHION				
* 3-356-925-01	HEAT SINK				
* 3-362-478-11	HOLDER (T), LED				
* 3-385-607-01	HOLDER, FL TUBE				
* 4-880-403-21	HEAT SINK				
* 7-685-871-01	SCREW +BVTT	3X6 (S)			
< CAPACITOR >					
△C001	1-161-744-00	CERAMIC	0.01uF		400V

Ref. No.	Part No.	Description	Remark		
C601	1-124-443-00	ELECT	100uF	20%	10V
C602	1-164-159-11	CERAMIC	0.1uF		50V
C603	1-162-294-31	CERAMIC	0.001uF	10%	50V
C604	1-162-294-31	CERAMIC	0.001uF	10%	50V
C701	1-136-177-00	FILM	1uF	5%	50V
C702	1-136-165-00	FILM	0.1uF	5%	50V
C703	1-104-644-11	ELECT	3300uF	20%	35
C704	1-104-644-11	ELECT	3300uF	20%	35
C705	1-124-927-11	ELECT	4.7uF	20%	100V
C706	1-126-105-11	ELECT	1000uF	20%	35V
C707	1-124-887-00	ELECT	3300uF	20%	16V
C708	1-124-903-11	ELECT	1uF	20%	50V
C709	1-124-471-00	ELECT	1000uF	20%	6.3V
C710	1-124-927-11	ELECT	4.7uF	20%	100V
C711	1-124-927-11	ELECT	4.7uF	20%	100V
C712	1-162-211-31	CERAMIC	33PF	5%	50V
C713	1-124-473-11	ELECT	1000uF	20%	10V
C714	1-126-955-11	ELECT	4700uF	20%	35V
C715	1-124-927-11	ELECT	4.7uF	20%	100V
C716	1-124-556-11	ELECT	2200uF	20%	16V
C717	1-124-122-11	ELECT	100uF	20%	50V
C718	1-124-477-11	ELECT	47uF	20%	25V
C719	1-164-159-11	CERAMIC	0.1uF		50V
C801	1-124-907-11	ELECT	10uF	20%	50V
C802	1-124-927-11	ELECT	4.7uF	20%	100V
C803	1-124-443-00	ELECT	100uF	20%	10V
C804	1-124-472-11	ELECT	470uF	20%	10V
C805	1-164-159-11	CERAMIC	0.1uF		50V
C806	1-164-159-11	CERAMIC	0.1uF		50V
C807	1-124-477-11	ELECT	47uF	20%	25V
C851	1-124-234-00	ELECT	22uF	20%	16V
C852	1-124-907-11	ELECT	10uF	20%	50V
C853	1-124-925-11	ELECT	2.2uF	20%	100V
C854	1-124-927-11	ELECT	4.7uF	20%	100V
< CONNECTOR >					
* CN001	1-580-230-31	PIN, CONNECTOR (PC BOARD) 2P			
* CN002	1-568-226-11	PIN, CONNECTOR 2P			
* CN701	1-564-506-11	PLUG, CONNECTOR 3P			
* CN702	1-564-511-11	PLUG, CONNECTOR 8P			
* CN801	1-564-339-51	PIN, CONNECTOR 5P			
* CN802	1-506-503-11	PIN, CONNECTOR 9P			
* CN803	1-564-341-51	PIN, CONNECTOR 7P			
< COMPOSITION CIRCUIT BLOCK >					
CP601	1-232-881-11	COMPOSITION CIRCUIT BLOCK			
CP602	1-236-985-11	COMPOSITION CIRCUIT BLOCK			
CP801	1-236-984-11	COMPOSITION CIRCUIT BLOCK			

The components identified by mark △ or dotted line with mark △ are critical for safety. Replace only with part number specified.

Les composants identifiés par une marque △ sont critiques pour la sécurité. Ne les remplacer que par une pièce portant le numéro spécifié.

# SYSTEM CONTROL

Ref. No.	Part No.	Description	Remark
----------	----------	-------------	--------

< DIODE >

D601	8-719-301-44	LED SEL2410E-D (▶)	
D602	8-719-301-61	LED SEL2910A-D (■)	
D603	8-719-301-39	LED SEL2210S-D (●)	
D604	8-719-987-63	DIODE 1N4148M	
D605	8-719-987-63	DIODE 1N4148M	
D606	8-719-987-63	DIODE 1N4148M	
D607	8-719-987-63	DIODE 1N4148M	
D701	8-719-230-02	DIODE 30DF2	
D702	8-719-230-02	DIODE 30DF2	
D703	8-719-230-02	DIODE 30DF2	
D704	8-719-230-02	DIODE 30DF2	
D705	8-719-200-77	DIODE 10E2N	
D706	8-719-200-77	DIODE 10E2N	
D707	8-719-200-77	DIODE 10E2N	
D708	8-719-200-77	DIODE 10E2N	
D709	8-719-200-77	DIODE 10E2N	
D710	8-719-987-63	DIODE 1N4148M	
D711	8-719-933-41	DIODE HZS6C3L	
D712	8-719-933-41	DIODE HZS6C3L	
D713	8-719-200-77	DIODE 10E2N	
D714	8-719-001-79	DIODE UZL-12H1	
D715	8-719-200-77	DIODE 10E2N	
D716	8-719-200-77	DIODE 10E2N	
D717	8-719-933-41	DIODE HZS6C3L	
D801	8-719-200-77	DIODE 10E2N	
D802	8-719-987-63	DIODE 1N4148M	
D803	8-719-987-63	DIODE 1N4148M	
D804	8-719-987-63	DIODE 1N4148M	
D851	8-719-987-63	DIODE 1N4148M	
D852	8-719-987-63	DIODE 1N4148M	
D853	8-719-987-63	DIODE 1N4148M	
D854	8-719-987-63	DIODE 1N4148M	
D855	8-719-987-63	DIODE 1N4148M	
D856	8-719-987-63	DIODE 1N4148M	
D857	8-719-987-63	DIODE 1N4148M	
D858	8-719-987-63	DIODE 1N4148M	
D859	8-719-987-63	DIODE 1N4148M	

< FLUORESCENT INDICATOR TUBE >

FLT601 1-517-139-11 INDICATOR TUBE, FLUORESCENT

< IC >

IC601	8-759-635-68	IC M50940-313SP	
IC801	8-759-635-69	IC M50964-226SP	
IC802	8-759-973-95	IC BA6219B	
IC803	8-759-822-09	IC LB1641	
IC851	8-741-100-48	IC SBX1610-59	

Ref. No.	Part No.	Description	Remark
----------	----------	-------------	--------

< TRANSISTOR >

Q601	8-729-900-61	TRANSISTOR DTA114ES	
Q602	8-729-900-61	TRANSISTOR DTA114ES	
Q603	8-729-900-61	TRANSISTOR DTA114ES	
Q604	8-729-900-61	TRANSISTOR DTA114ES	
Q605	8-729-900-61	TRANSISTOR DTA114ES	
Q606	8-729-900-61	TRANSISTOR DTA114ES	
Q607	8-729-900-65	TRANSISTOR DTA144ES	
Q608	8-729-900-65	TRANSISTOR DTA144ES	
Q609	8-729-900-65	TRANSISTOR DTA144ES	
Q610	8-729-900-65	TRANSISTOR DTA144ES	
Q611	8-729-900-65	TRANSISTOR DTA144ES	
Q612	8-729-900-65	TRANSISTOR DTA144ES	
Q613	8-729-900-89	TRANSISTOR DTC144ES	
Q614	8-729-900-65	TRANSISTOR DTA144ES	
Q701	8-729-209-15	TRANSISTOR 2SD2012	
Q702	8-729-209-15	TRANSISTOR 2SD2012	
Q703	8-729-209-15	TRANSISTOR 2SD2012	
Q704	8-729-620-05	TRANSISTOR 2SC2603-EF	
Q705	8-729-620-05	TRANSISTOR 2SC2603-EF	
Q706	8-729-620-05	TRANSISTOR 2SC2603-EF	
Q707	8-729-620-05	TRANSISTOR 2SC2603-EF	
Q708	8-729-140-04	TRANSISTOR 2SB1116A-L	
Q709	8-729-141-32	TRANSISTOR 2SA1409-LK	
Q801	8-729-620-05	TRANSISTOR 2SC2603-EF	
Q802	8-729-620-05	TRANSISTOR 2SC2603-EF	
Q803	8-729-900-61	TRANSISTOR DTA114ES	
Q804	8-729-119-76	TRANSISTOR 2SA1175-HFE	
Q805	8-729-119-76	TRANSISTOR 2SA1175-HFE	
Q806	8-729-900-65	TRANSISTOR DTA144ES	
Q807	8-729-900-65	TRANSISTOR DTA144ES	
Q808	8-729-900-65	TRANSISTOR DTA144ES	
Q809	8-729-900-65	TRANSISTOR DTA144ES	
Q810	8-729-900-65	TRANSISTOR DTA144ES	
Q811	8-729-119-76	TRANSISTOR 2SA1175-HFE	
Q812	8-729-900-65	TRANSISTOR DTA144ES	
Q813	8-729-900-65	TRANSISTOR DTA144ES	
Q814	8-729-119-76	TRANSISTOR 2SA1175-HFE	
Q815	8-729-900-89	TRANSISTOR DTC144ES	
Q851	8-729-900-80	TRANSISTOR DTC114ES	
Q852	8-729-900-65	TRANSISTOR DTA144ES	
Q854	8-729-900-80	TRANSISTOR DTC114ES	

< RESISTOR >

R601	1-249-429-11	CARBON	10K	5%	1/4W
R602	1-249-429-11	CARBON	10K	5%	1/4W
R603	1-249-437-11	CARBON	47K	5%	1/4W
R604	1-247-903-00	CARBON	1M	5%	1/4W

# SYSTEM CONTROL

Ref. No.	Part No.	Description	Remark		
R605	1-249-421-11	CARBON	2. 2K	5%	1/4W
R606	1-249-421-11	CARBON	2. 2K	5%	1/4W
R607	1-249-421-11	CARBON	2. 2K	5%	1/4W
R608	1-249-421-11	CARBON	2. 2K	5%	1/4W
R609	1-249-429-11	CARBON	10K	5%	1/4W
R610	1-249-425-11	CARBON	4. 7K	5%	1/4W
R611	1-249-422-11	CARBON	2. 7K	5%	1/4W
R612	1-249-424-11	CARBON	3. 9K	5%	1/4W
R613	1-249-428-11	CARBON	8. 2K	5%	1/4W
R614	1-249-434-11	CARBON	27K	5%	1/4W
R615	1-249-422-11	CARBON	2. 7K	5%	1/4W
R616	1-249-424-11	CARBON	3. 9K	5%	1/4W
R617	1-249-428-11	CARBON	8. 2K	5%	1/4W
R618	1-249-434-11	CARBON	27K	5%	1/4W
R619	1-249-431-11	CARBON	15K	5%	1/4W
R620	1-249-434-11	CARBON	27K	5%	1/4W
R621	1-249-409-11	CARBON	220	5%	1/4W
R622	1-249-410-11	CARBON	270	5%	1/4W
R623	1-249-412-11	CARBON	390	5%	1/4W
△R701	1-212-863-00	FUSIBLE	18	5%	1/4W F
R702	1-247-752-11	CARBON	1K	5%	1/2W
R703	1-249-425-11	CARBON	4. 7K	5%	1/4W
R704	1-249-421-11	CARBON	2. 2K	5%	1/4W
R705	1-249-437-11	CARBON	47K	5%	1/4W
R706	1-249-425-11	CARBON	4. 7K	5%	1/4W
R707	1-249-421-11	CARBON	2. 2K	5%	1/4W
R708	1-249-421-11	CARBON	2. 2K	5%	1/4W
R709	1-249-421-11	CARBON	2. 2K	5%	1/4W
R710	1-249-427-11	CARBON	6. 8K	5%	1/4W
R711	1-249-425-11	CARBON	4. 7K	5%	1/4W
R712	1-249-421-11	CARBON	2. 2K	5%	1/4W
R713	1-249-431-11	CARBON	15K	5%	1/4W
R714	1-249-429-11	CARBON	10K	5%	1/4W
R715	1-249-425-11	CARBON	4. 7K	5%	1/4W
R716	1-249-437-11	CARBON	47K	5%	1/4W
R801	1-249-425-11	CARBON	4. 7K	5%	1/4W
R802	1-249-417-11	CARBON	1K	5%	1/4W
R803	1-249-435-11	CARBON	33K	5%	1/4W
R804	1-249-437-11	CARBON	47K	5%	1/4W
R805	1-249-440-11	CARBON	82K	5%	1/4W
R806	1-249-413-11	CARBON	470	5%	1/4W
R807	1-247-903-00	CARBON	1M	5%	1/4W
R808	1-249-429-11	CARBON	10K	5%	1/4W
R810	1-249-437-11	CARBON	47K	5%	1/4W
R811	1-249-437-11	CARBON	47K	5%	1/4W
R812	1-249-421-11	CARBON	2. 2K	5%	1/4W
R813	1-249-421-11	CARBON	2. 2K	5%	1/4W
R814	1-249-429-11	CARBON	10K	5%	1/4W

Ref. No.	Part No.	Description	Remark		
R815	1-249-429-11	CARBON	10K	5%	1/4W
R816	1-249-429-11	CARBON	10K	5%	1/4W
R817	1-249-429-11	CARBON	10K	5%	1/4W
R818	1-249-429-11	CARBON	10K	5%	1/4W
R819	1-249-429-11	CARBON	10K	5%	1/4W
R820	1-249-436-11	CARBON	39K	5%	1/4W
R821	1-249-436-11	CARBON	39K	5%	1/4W
R822	1-249-437-11	CARBON	47K	5%	1/4W
R823	1-249-433-11	CARBON	22K	5%	1/4W
R824	1-249-426-11	CARBON	5. 6K	5%	1/4W
R825	1-249-413-11	CARBON	470	5%	1/4W
R826	1-249-429-11	CARBON	10K	5%	1/4W
R827	1-249-429-11	CARBON	10K	5%	1/4W
R828	1-249-425-11	CARBON	4. 7K	5%	1/4W
R829	1-249-425-11	CARBON	4. 7K	5%	1/4W
R830	1-249-484-11	CARBON	6. 8	5%	1/2W
R831	1-249-427-11	CARBON	6. 8K	5%	1/4W
R832	1-249-428-11	CARBON	8. 2K	5%	1/4W
R833	1-249-428-11	CARBON	8. 2K	5%	1/4W
R834	1-249-425-11	CARBON	4. 7K	5%	1/4W
R835	1-249-425-11	CARBON	4. 7K	5%	1/4W
R836	1-249-484-11	CARBON	6. 8	5%	1/2W
R837	1-249-429-11	CARBON	10K	5%	1/4W
R851	1-249-431-11	CARBON	15K	5%	1/4W
R852	1-249-437-11	CARBON	47K	5%	1/4W
R853	1-249-437-11	CARBON	47K	5%	1/4W
R854	1-249-429-11	CARBON	10K	5%	1/4W
R855	1-249-429-11	CARBON	10K	5%	1/4W
R856	1-249-437-11	CARBON	47K	5%	1/4W
R857	1-249-429-11	CARBON	10K	5%	1/4W
R859	1-249-437-11	CARBON	47K	5%	1/4W
R860	1-249-429-11	CARBON	10K	5%	1/4W

< VARIABLE RESISTOR >

RV801 1-241-629-11 RES, ADJ, CARBON 4. 7K  
 RV851 1-223-266-11 RES, VAR, CARBON 10K (BIAS-CAL)

< SWITCH >

△S001 1-572-267-51 SWITCH, PUSH (AC POWER) (1 KEY)  
 S601 1-554-303-21 SWITCH, TACTILE (MEMORY)  
 S602 1-554-303-21 SWITCH, TACTILE (RESET)  
 S603 1-554-303-21 SWITCH, TACTILE (☰)  
 S604 1-554-303-21 SWITCH, TACTILE (■)  
 S605 1-554-303-21 SWITCH, TACTILE (◀◀)  
 S606 1-554-303-21 SWITCH, TACTILE (▶▶)  
 S607 1-554-303-21 SWITCH, TACTILE (●)  
 S608 1-554-303-21 SWITCH, TACTILE (▶)  
 S609 1-554-303-21 SWITCH, TACTILE (▣)

The components identified by mark △ or dotted line with mark. △ are critical for safety. Replace only with part number specified.

Les composants identifiés par une marque △ sont critiques pour la sécurité. Ne les remplacer que par une pièce portant le numéro spécifié.

**SYSTEM CONTROL**

Ref. No.	Part No.	Description	Remark
S610	1-554-303-21	SWITCH, TACTILE (K)	
S611	1-554-303-21	SWITCH, TACTILE (M)	
S612	1-554-303-21	SWITCH, TACTILE (O)	
S613	1-571-520-11	SWITCH, SLIDE (TIMER)	
S851	1-554-303-21	SWITCH, TACTILE (MONITOR)	
S852	1-692-368-11	SWITCH, ROTARY (DOLBY NR)	
S853	1-692-376-11	SWITCH, PUSH (1 KEY) (CALIBRATION)	
S854	1-692-376-11	SWITCH, PUSH (1 KEY) (MPX FILTER)	
S855	1-692-376-11	SWITCH, PUSH (1 KEY) (HX PRO)	

< TERMINAL >

\* TB701 4-942-204-01 PLATE, GROUND

< TEST PIN >

\* TP801 1-564-506-11 PLUG, CONNECTOR 3P

< VIBRATOR >

X601 1-577-358-21 VIBRATOR, CERAMIC 4MHz  
 X801 1-577-358-21 VIBRATOR, CERAMIC 4MHz

\*\*\*\*\*

MISCELLANEOUS  
 \*\*\*\*\*

△S002 1-692-155-11 SELECTOR, POWER VOLTAGE (E)  
 \* 53 1-590-321-61 LEAD (WITH CONNECTOR)  
 △57 1-558-568-21 CORD, POWER (AEP, G)  
 △57 1-559-583-21 CORD, POWER (US, CND)  
 △57 1-696-027-11 CORD, POWER (E)

116 8-719-980-85 DIODE (SLF325C)  
 \* 147 1-608-268-00 PC BOARD, ERASE HEAD  
 158 1-632-779-11 PC BOARD, FG  
 △F701 1-532-285-00 FUSE, TIME-LAG (1.25A/250V) (AEP, G, E)  
 △F701 1-532-741-11 FUSE, GLASS TUBE (1.25A/125V) (US, CND)

HE501 1-543-836-11 HEAD, MAGNETIC (ERASE)  
 HRP501 1-543-684-21 HEAD, MAGNETIC (REC/PB)  
 M1001 X-3356-638-1 MOTOR (REEL R) ASSY  
 M1002 X-3356-604-1 MOTOR (ASSIST) ASSY  
 S1001 1-466-238-11 ENCODER, ROTARY

△T901 1-423-684-11 TRANSFORMER, POWER (US, CND)  
 △T901 1-423-685-11 TRANSFORMER, POWER (AEP, G)  
 △T901 1-423-686-11 TRANSFORMER, POWER (E)

\*\*\*\*\*

ACCESSORIES & PACKING MATERIALS  
 \*\*\*\*\*

1-465-314-11 REMOTE COMMANDER (RM-J701) (E)  
 1-558-271-11 CORD, CONNECTION  
 1-569-007-11 ADAPTER, CONVERSION 2P (E)  
 2-181-754-01 COVER, BATTERY (FOR RM-J701) (E)

Ref. No.	Part No.	Description	Remark
	3-704-366-01	SCREW (CASE) (M3X8)	
*	3-354-919-61	INDIVIDUAL CARTON	
*	3-366-547-01	CUSHION	
	3-756-186-11	MANUAL, INSTRUCTION (ENGLISH, FRENCH, SPANISH, PORTUGUESE) (CND, AEP, E)	
	3-756-186-21	MANUAL, INSTRUCTION (ENGLISH) (US)	
	3-756-186-41	MANUAL, INSTRUCTION (GERMAN, DUTCH, SWEDISH, ITALIAN) (AEP)	
	3-756-186-51	MANUAL, INSTRUCTION (GERMAN) (G)	

\*\*\*\*\*

\*\*\*\*\*  
**HARDWARE LIST**  
 \*\*\*\*\*

- #1 7-685-871-01 SCREW +BVTT 3X6 (S)
- #2 7-682-547-09 SCREW +BV 3X6, S TIGHT
- #3 7-685-133-19 SCREW +BTP 2.6X6 TYPE2 N-S
- #4 7-682-147-15 SCREW, TR
- #5 7-682-548-09 SCREW +BVTT 3X8 (S)
- #6 7-621-849-00 SCREW (BV/RING)
- #7 7-621-775-10 SCREW +B 2.6X4
- #8 7-628-253-00 SCREW +PS 2X4
- #9 7-621-255-20 SCREW +BVTT 2X4 (S)
- #10 7-621-772-10 SCREW +B 2X4
- #11 7-671-154-01 STENLESS BALL
- #12 7-685-870-01 SCREW +BVTT 3X5 (S)
- #13 7-621-772-70 SCREW +B 2X14
- #14 7-622-205-05 NUT M2 TYPE2
- #15 7-628-254-10 SCREW +PS 2.6X6
- #16 7-682-648-09 SCREW +PS 3X8
- #17 7-621-255-35 SCREW +BVTT 2X5 (S)
- #18 7-685-646-79 SCREW +BVTP 3X8 TYPE2 N-S (E)

The components identified by mark △ or dotted line with mark. △ are critical for safety. Replace only with part number specified.	Les composants identifiés par une marque △ sont critiques pour la sécurité. Ne les remplacer que par une pièce portant le numéro spécifié.
---	--