

# TC-KB920S

## SERVICE MANUAL

*AEP Model  
E Model  
Australian Model*



Dolby noise reduction and HX Pro headroom extension manufactured under license from Dolby Laboratories Licensing Corporation. HX Pro originated by Bang & Olufsen. "DOLBY", the double-D symbol  $\square\square$ , and "HX PRO" are trademarks of Dolby Laboratories Licensing Corporation.

Model Name Using Similar Mechanism	TC-KE500S
Tape Transport Mechanism Type	TCM-190VB14

### SPECIFICATIONS

#### System

##### Recording system

4-track 2-channel stereo

##### Fast winding time (approx.)

90 sec. (with Sony C-60 cassette)

##### High-speed fast-winding time (approx.)

45 sec. (with Sony C-60 cassette)

#### Bias

AC bias

#### Heads

Erasing head  $\times$  1 (S&F head)  
Recording head  $\times$  1 (SD head)  
Playing head  $\times$  1 (SD head)

#### Motors

Capstan motor  $\times$  1 (DC servo motor)  
Reel motor  $\times$  1 (DC motor)

#### Signal-to-noise ratio (at peak level, weighted, and with Dolby NR off)

Type I tape, Sony Type I (NORMAL): 57 dB  
Type II tape, Sony Type II (HIGH): 59 dB  
Type IV tape, Sony Type IV (METAL): 61 dB

#### S/N ratio improvement (approximate values)

With Dolby B NR on: 5 dB at 1 kHz, 10 dB at 5 kHz  
With Dolby C NR on: 15 dB at 500 Hz, 20 dB at 1 kHz  
With Dolby S NR on: 10 dB at 100 Hz, 24 dB at 1 kHz

#### Harmonic distortion

0.4% (with Type I tape, Sony Type I (NORMAL):  
160n Wb/m 315 Hz, 3rd H.D.)  
1.5% (with Type IV tape, Sony Type IV (METAL):  
250n Wb/m 315 Hz, 3rd H.D.)

#### Frequency response (Dolby NR off)

Type I tape, Sony Type I (NORMAL):  
20 - 17,000 Hz ( $\pm$ 3 dB, IEC)  
15 - 18,000 Hz ( $\pm$ 6 dB)  
Type II tape, Sony Type II (HIGH):  
20 - 18,000 Hz ( $\pm$ 3 dB, IEC)  
15 - 19,000 Hz ( $\pm$ 6 dB)  
Type IV tape, Sony Type IV (METAL):  
20 - 20,000 Hz ( $\pm$ 3 dB, IEC)  
20 - 16,000 Hz ( $\pm$ 3 dB, -4dB recording)  
15 - 21,000 Hz ( $\pm$ 6 dB)

#### Inputs

##### Line inputs (phono jacks)

Sensitivity: 0.16 V  
Input impedance: 47 kilohms

— Continued on next page —

## STEREO CASSETTE DECK

# SONY®



## Outputs

### Line outputs (phono jacks)

Rated output level: 0.5 V at a load impedance of  
47 kilohms  
Load impedance: Over 10 kilohms

### Headphones (stereo phone jack)

Output level: 0.25 mW at a load impedance of  
32 ohms

## General

### Power requirements

Where purchased	Power requirements
Continental Europe	220 - 230 V AC, 50/60 Hz
Australia	240 V AC, 50/60 Hz
Other countries	120, 220, or 230 - 240 V AC, 50/60Hz adjustable with the voltage selector

### Power consumption

23 W

### Dimensions (approx.) (w/h/d)

430 × 123 × 305 mm  
incl. projecting parts and controls

### Mass (approx.)

5.1 kg

### Supplied accessories

Audio connecting cords (2)

Design and specifications are subject to change without notice.

## Flexible Circuit Board Repairing

- Keep the temperature of the soldering iron around 270 °C during repairing.
- Do not touch the soldering iron on the same conductor of the circuit board (within 3 times).
- Be careful not to apply force on the conductor when soldering or unsoldering.

## Notes on chip component replacement

- Never reuse a disconnected chip component.
- Notice that the minus side of a tantalum capacitor may be damaged by heat.

## MODEL IDENTIFICATION

– BACK PANEL –

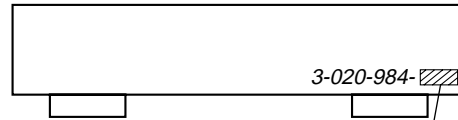

AEP Model : 0   
Australian Model : 2   
Malaysia, Singapore Model: 3

## SAFETY-RELATED COMPONENT WARNING!!

COMPONENTS IDENTIFIED BY MARK  $\triangle$  OR DOTTED LINE WITH MARK  $\triangle$  ON THE SCHEMATIC DIAGRAMS AND IN THE PARTS LIST ARE CRITICAL TO SAFE OPERATION. REPLACE THESE COMPONENTS WITH SONY PARTS WHOSE PART NUMBERS APPEAR AS SHOWN IN THIS MANUAL OR IN SUPPLEMENTS PUBLISHED BY SONY.

## TABLE OF CONTENTS

<b>1. GENERAL</b> .....	4
<b>2. DISASSEMBLY</b> .....	5
<b>3. MECHANICAL ADJUSTMENTS</b> .....	9
<b>4. ELECTRICAL ADJUSTMENTS</b> .....	10
<b>5. DIAGRAMS</b>	
5-1. Note for Printed Wiring Boards and Schematic Diagrams .....	14
5-2. Printed Wiring Boards – MD Section – .....	15
5-3. Schematic Diagram – MD Section – .....	17
5-4. Printed Wiring Board – MAIN Section – .....	19
5-5. Schematic Diagram – MAIN Section – (1/2) .....	21
5-6. Schematic Diagram – MAIN Section – (2/2) .....	23
5-7. Printed Wiring Board – DOLBY-S Section – .....	25
5-8. Schematic Diagram – DOLBY-S Section – .....	25
5-9. Printed Wiring Boards – POWER Section – .....	27
5-10. Schematic Diagram – POWER Section – .....	28
5-11. Printed Wiring Boards – PANEL Section – .....	29
5-12. Schematic Diagram – PANEL Section – .....	31
5-13. IC Pin Function Description .....	33
<b>6. EXPLODED VIEWS</b> .....	35
<b>7. ELECTRICAL PARTS LIST</b> .....	40

# SECTION 1 GENERAL

## LOCATION OF CONTROLS

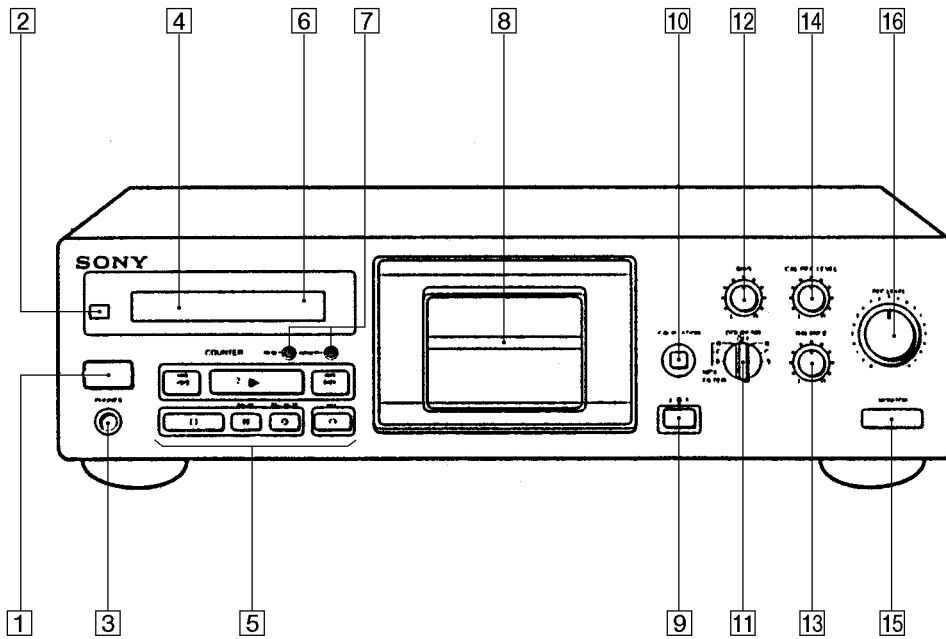

- |                                 |                                 |
|---------------------------------|---------------------------------|
| <b>1</b> I/O (Power) button     | <b>9</b> ≡ EJECT button         |
| <b>2</b> Remote control sensor  | <b>10</b> AUTO CAL button       |
| <b>3</b> PHONES jack            | <b>11</b> DOLBY NR switch       |
| <b>4</b> Display panel          | <b>12</b> BIAS control          |
| <b>5</b> Tape operation buttons | <b>13</b> BALANCE control       |
| AMS* ◀◀ button                  | <b>14</b> CAL REC LEVEL control |
| ▷▶ button                       | <b>15</b> MONITOR button        |
| ■ button                        | <b>16</b> REC LEVEL control     |
| ▬ PAUSE button                  |                                 |
| ○ REC MUTING button             |                                 |
| ● REC button                    |                                 |
| <b>6</b> Tape counter           |                                 |
| <b>7</b> Counter buttons        |                                 |
| RESET button                    |                                 |
| MEMORY button                   |                                 |
| <b>8</b> Cassette holder        |                                 |

\* AMS is an abbreviation for Automatic Music Sensor.

## SECTION 2 DISASSEMBLY

**Note:** Follow the disassembly procedure in the numerical order given.

### CASE

Unscrew the four case attachment seven tapping screws and remove the case.

### FRONT PANEL SECTION

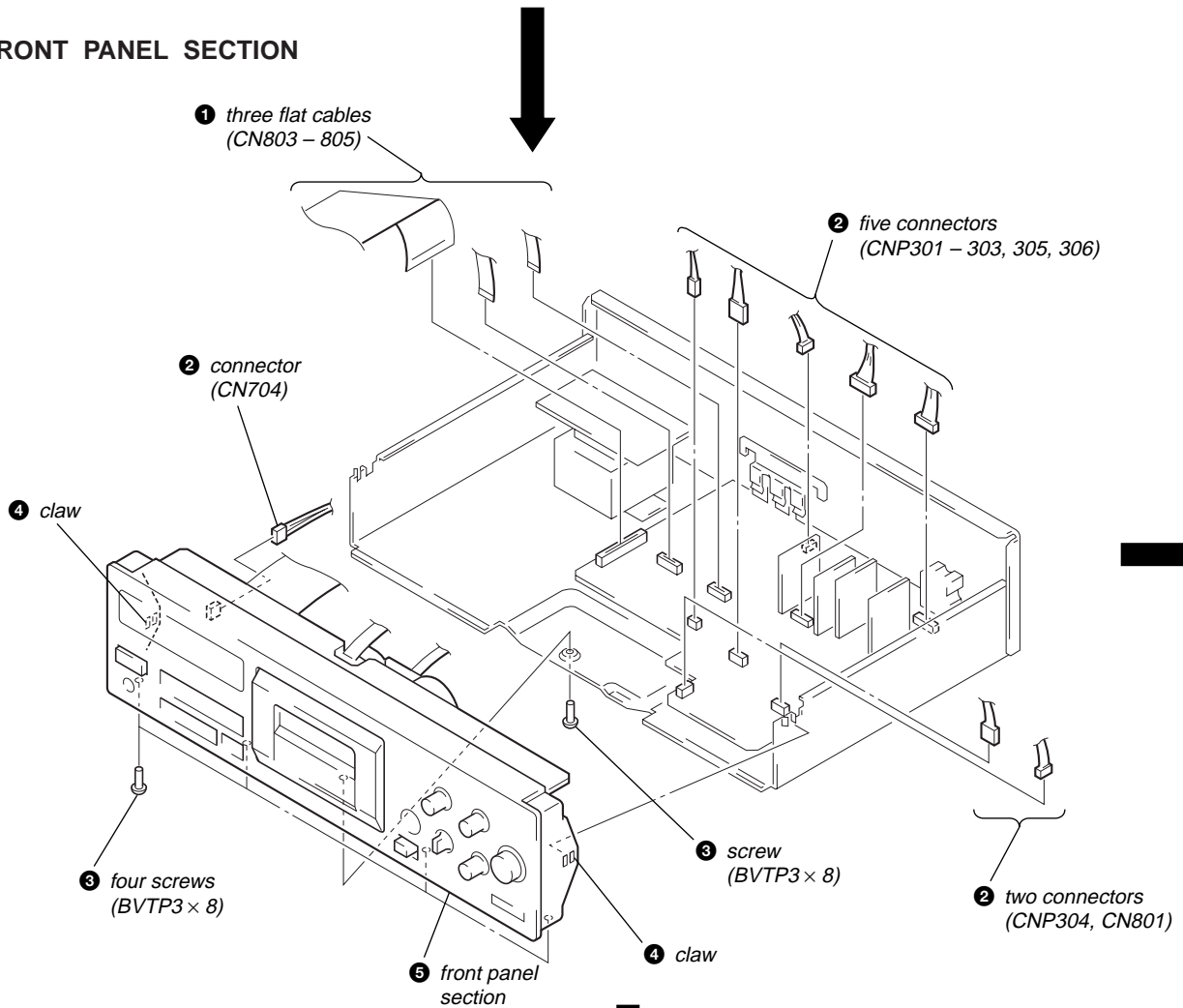

### MD ASS'Y SECTION

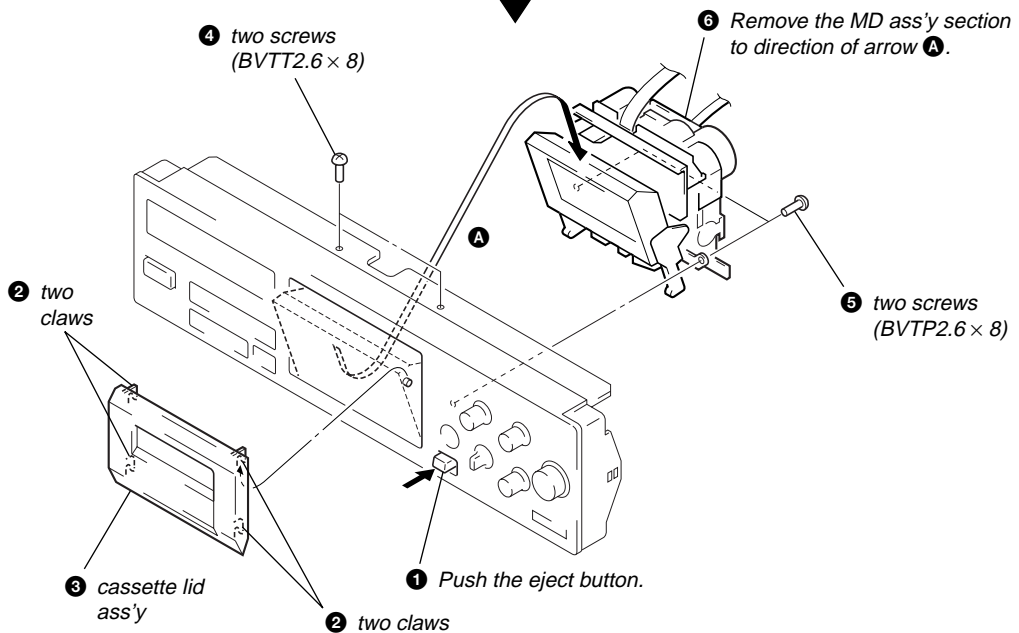

## MAIN BOARD

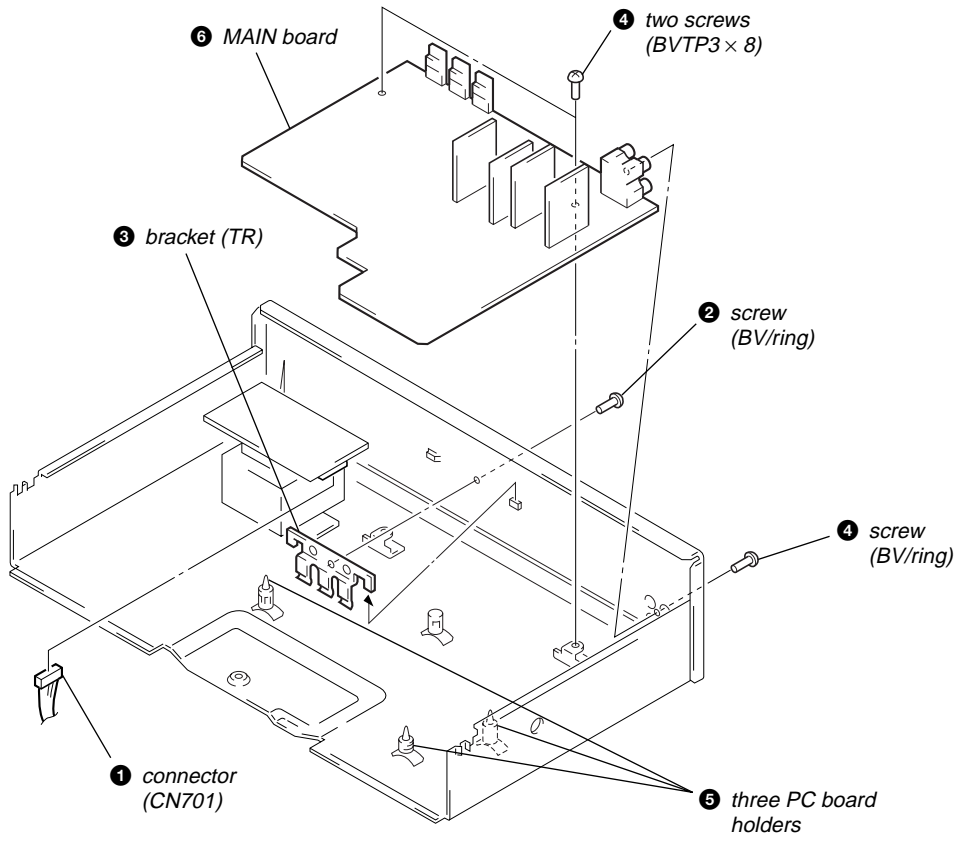

## CASSETTE HOLDER (R) ASS'Y

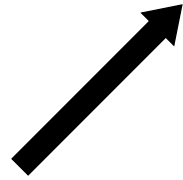
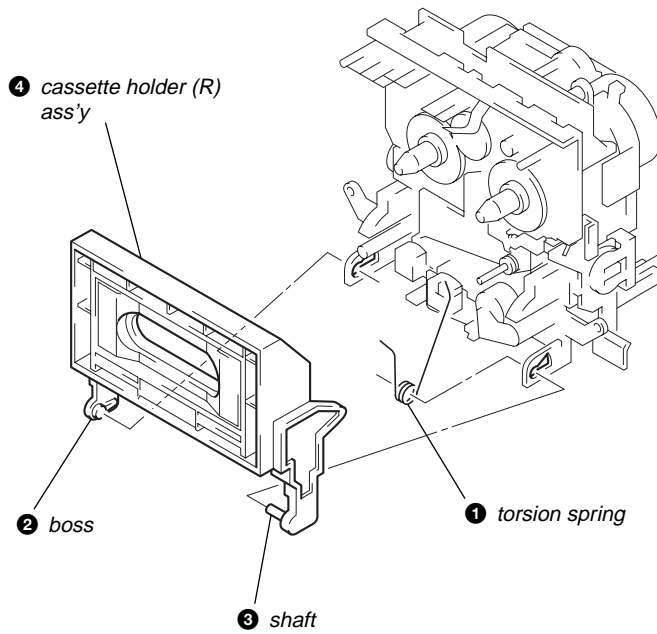

## FITTING BASE BLOCK

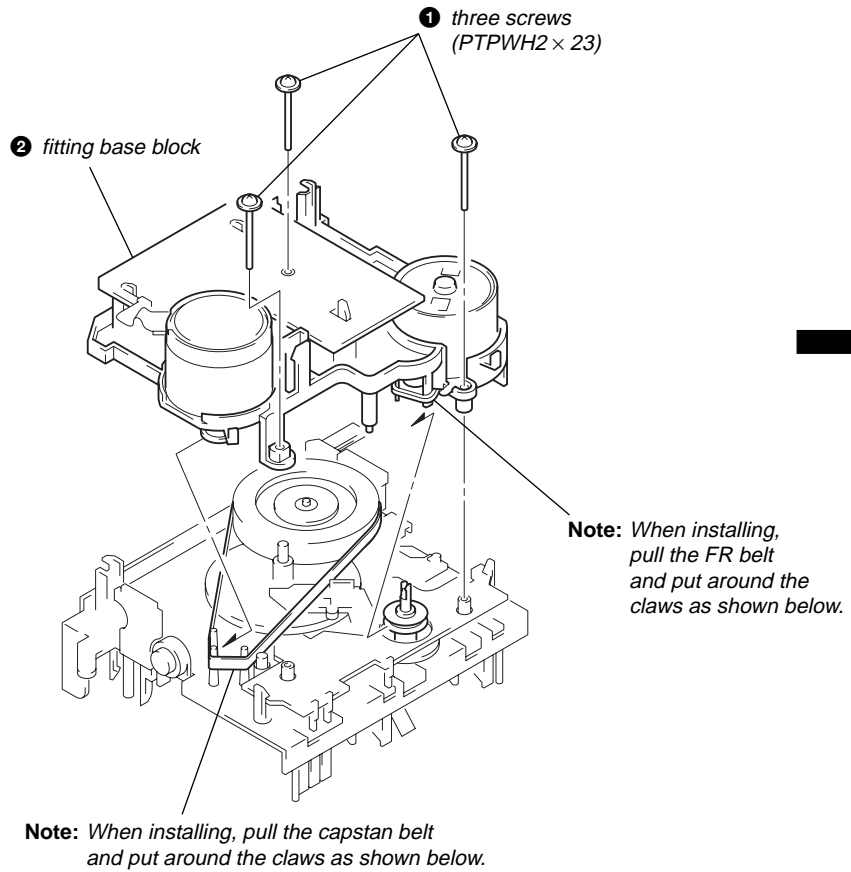

## HEAD

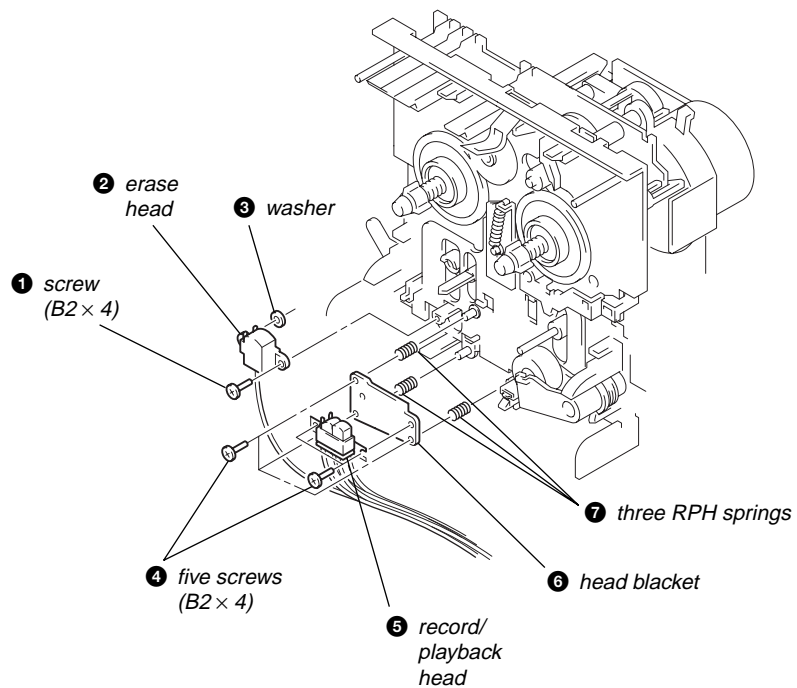

## AUDIO BOARD AND MOTOR

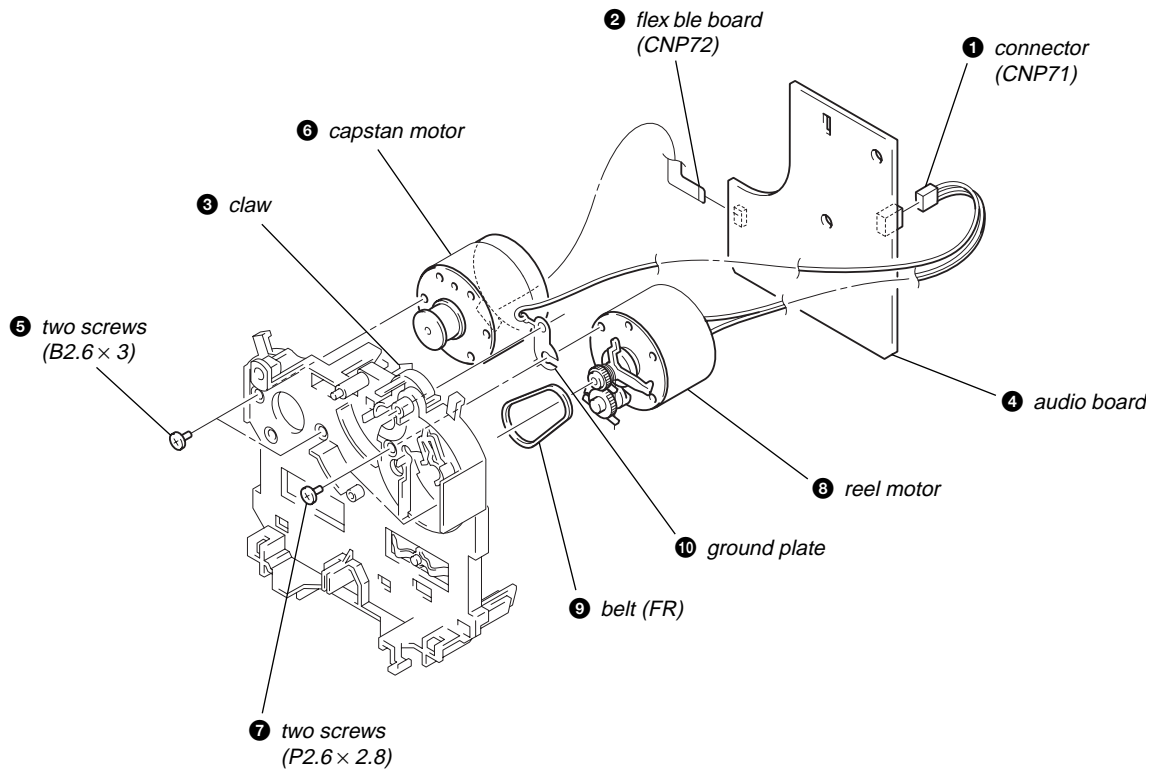



## SECTION 3 MECHANICAL ADJUSTMENTS

### PRECAUTION

1. Clean the following parts with a denatured alcohol-moistened swab:
 

record/playback/erase head	pinch roller
rubber belts	capstan
idler	
2. Demagnetize the record/playback head with a head demagnetizer.  
(Head demagnetizer do not approach for the erase head.)
3. Do not use a magnetized screwdriver for the adjustment.
4. After the adjustments, apply suitable locking compound to the parts adjusted.
5. The adjustments should be performed with the rated power supply voltage unless otherwise noted.

### • Torque Measurement

Mode	Torque Meter	Meter Reading
Forward	CQ-102C	30 to 65 g•cm (0.42 to 0.90 oz•inch)
Forward back tension	CQ-102C	1 to 6 g•cm (0.014 to 0.08 oz•inch)
FF/REW	CQ-201B	70 to 120 g•cm (0.98 to 1.66 oz•inch)

### Record/Playback Head Height/Declination Adjustment Procedures:

1. Test cassette: CQ-009C
2. Insert the mirror cassette and put the unit in record/Playback mode.
- 1) Height Adjustment:  
Check to see if the tape is curling at the tape guide of the head. If it is curling, tighten screws **A**, **B** and **C**, respectively by the same angle, moving the head so that it remains at the same angle throughout the procedure. If it curls on the bottom side of the mirror cassette (actually the inner side), tighten all the screws equally; but loosen them if the tape begins to curl on the top side. (outer side.)

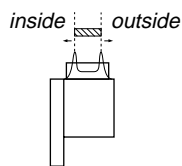

*Normal  
(Record/playback head  
as seen from the side of  
the erasehead.)*

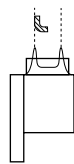

*Curling on the inner  
side  
Tighten screws **A**, **B**  
and **C**.*

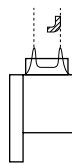

*Curling on  
the outer side  
Loosen screws **A**,  
**B** and **C**.*

- 2) Declination Adjustment:

While in the record/playback position, set the back tension to 0 (wind the supply reel with something thin like a pencil in a counterclockwise direction) and make sure there is no curling or shifting (shifting up/shifting down) at the guide of the record/playback head.

Because shifting can only occur due to a difference in the width of the tape and that of the tape guides (curling will otherwise occur), it is necessary to pay close attention since it can be easily overlooked.

When there is a shift, tighten screws B and C equally and change the declination of the head. If the tape is shifting up, tighten the screws, and if it is shifting down, loosen them.

Repeat the adjustments in steps 1) to 2) and fine adjust the height and the declination.

**Adjustment Location:** – record/playback head –

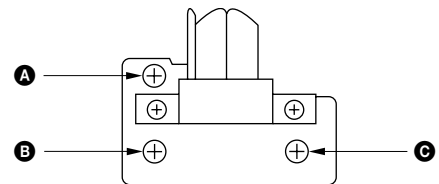

## SECTION 4 ELECTRICAL ADJUSTMENTS

**Note:** The adjustment should be performed in the order given in the service manual. As a rule, adjustments about playback should be performed before those about recording.

The adjustments should be performed before for both L-CH and R-CH.

- Switches and controls should be set as follows unless otherwise specified.

DOLBY NR, MPX FILTER switch: OFF

MONITOR switch: Tape

- Standard Record:

Deliver the standard input signal level to the input jack and set the REC LEVEL control to obtain the standard output signal level.

– Record Mode –

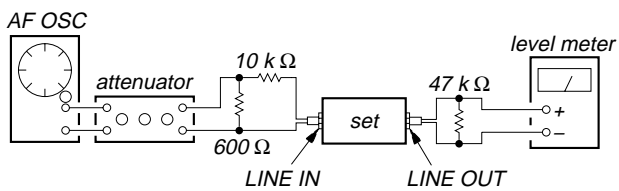

0 dB=0.775 V

### Standard Input Level

input terminal	LINE IN
source impedance	10 kΩ
input signal level	0.5 V (-3.8 dB)

### Standard Output Level

output terminal	LINE OUT
load impedance	47 kΩ
output signal level	0.5 V (-3.8 dB)

### Test Tape

Type	Signal	Used for
P-4-A100	10 kHz, -10 dB	Azimuth Adjustment
P-4-L300	315 Hz, 0 dB	Playback Level Adjustment
WS-48B	3 kHz, 0 dB	Tape Speed Adjustment

### Record/Playback Head Azimuth Adjustment

#### Procedure:

- Mode: FWD playback

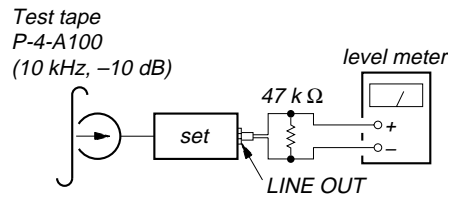

- Turn the adjustment screw for the maximum output levels. If these levels do not match, turn the adjustment screw until both of output levels match together within 1 dB.

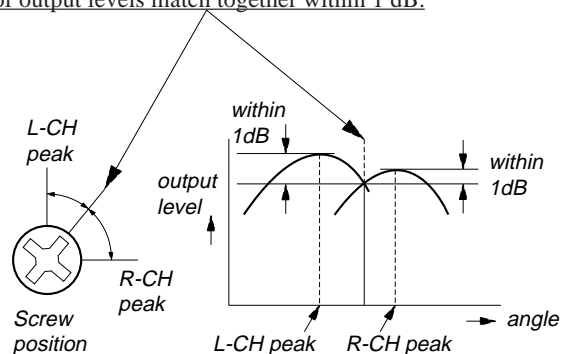

- Phase Check  
Mode: playback

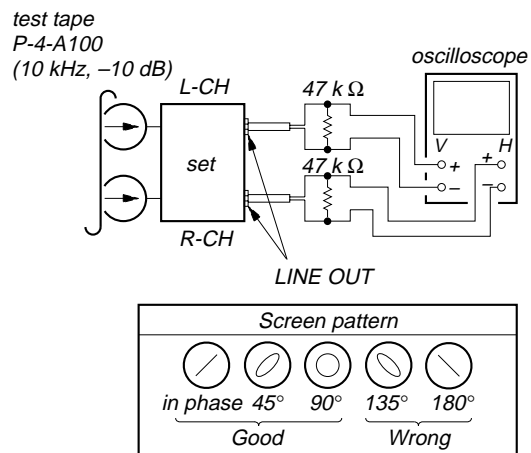

- After the adjustment, lock the screw with locking compound.

**Adjustment Location:** Record/Playback head

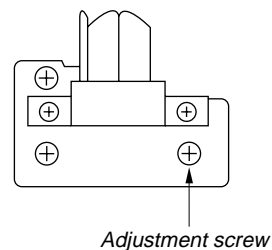

### Tape Speed Adjustment

#### Procedure:

Mode: playback

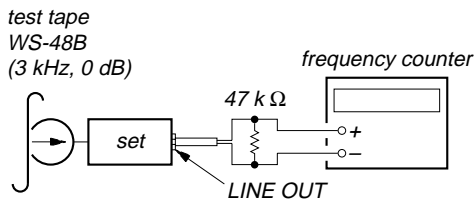

1. Set to FWD playback mode.
2. Adjust RV71 so that the frequency counter reading becomes  $3,000 \pm 90$  Hz.
3. Frequency difference between the beginning and the end of the tape should be within 3%.

**Adjustment Location:** AUDIO board (See page 12.)

Sample value of Wow and Flutter: 0.3% or less W.RMS (JIS) (WS-48B)

### Playback Level Adjustment

#### Procedure:

Mode: playback

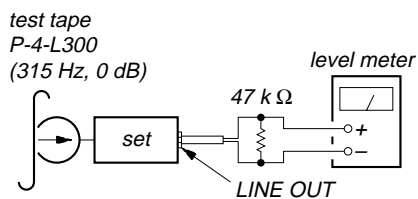

Adjust RV121 (L-CH) and RV221 (R-CH) so that the reading on level meter meets the adjustment limits below.

#### Adjustment Limits:

LINE OUT level:  $-7.7 \pm 0.5$  dB (0.301 to 0.338 V)

Level difference between channels: within 0.5 dB

Check that the LINE OUT level does not change even if Playback and Stop operation is repeated several times.

**Adjustment Location:** MAIN board (See page 12.)

### Bias Consumption Current Adjustment

#### Procedure:

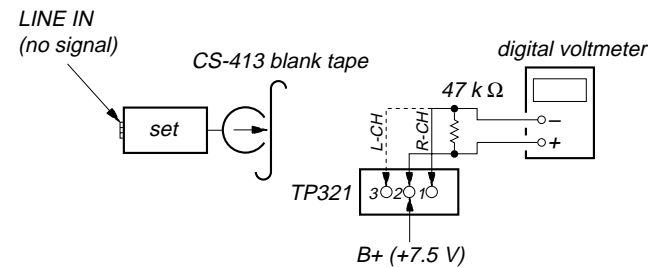

1. Set RV103 (L-CH) and RV203 (R-CH) to mechanical center and turn the set recording mode.
2. Connect digital voltmeter as shown by the following table.
3. Adjust the following transformers for the minimum readings on the digital voltmeter.

	Measurement Point	Adjustment Part	Value
L-CH	② and ③, TP321	T101	minimum
R-CH	① and ②, TP321	T201	

**Adjustment Location:** MAIN board (See page 12.)

### Record Bias Adjustment

#### Setting:

REC LEVEL control: Standard Record (See page 10.)

#### Procedure:

1. Mode: record and playback

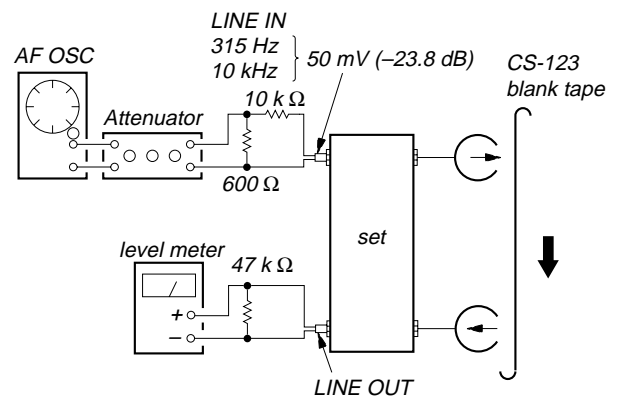

2. Adjust RV103 (L-CH) and RV203 (R-CH) so that 10 kHz playback output is  $0 \pm 0.3$  dB relative to the 315 Hz output.

**Adjustment Location:** MAIN board (See page 12.)

## Record Level Adjustment

### Setting:

REC LEVEL control: Standard Record (See page 10.)

### Procedure:

1. Mode: record and playback

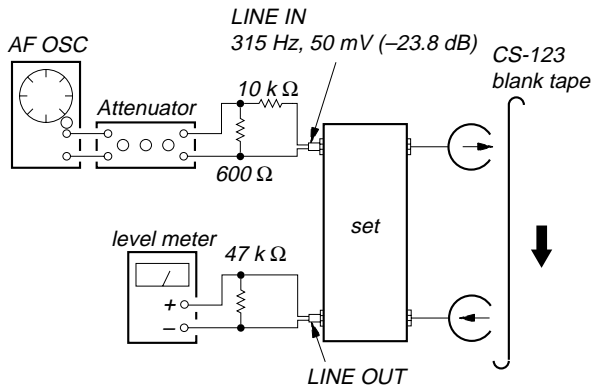

2. Adjust RV101 (L-CH) and RV201 (R-CH) so that the reading on level meter meets the adjustment limits below.

**Adjustment Limits:**  $-23.8 \pm 0.5$  dB (47.2 to 53 mV)

**Adjustment Location:** MAIN board

## Record EQ (IV) Adjustment

### Setting:

REC LEVEL control: Standard Record (See page 10.)

### Procedure:

1. Mode: record and playback

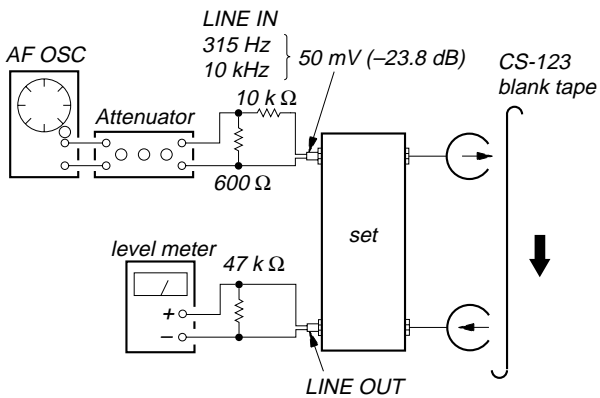

2. Adjust RV102 and RV202 so that they become maximum.
3. Adjust RV102 (L-CH) and RV202 (R-CH) so that the difference between R-CH and L-CH at 10 kHz is within 1 dB.
4. Adjust RV306 so that the R-CH meet the specification.

### Adjustment Limits:

10 kHz level difference against 315 Hz reference.  
 $0 \pm 1.0$  dB

**Adjustment Location:** MAIN board

### Adjustment Location:

[MAIN BOARD] – COMPONENT SIDE –

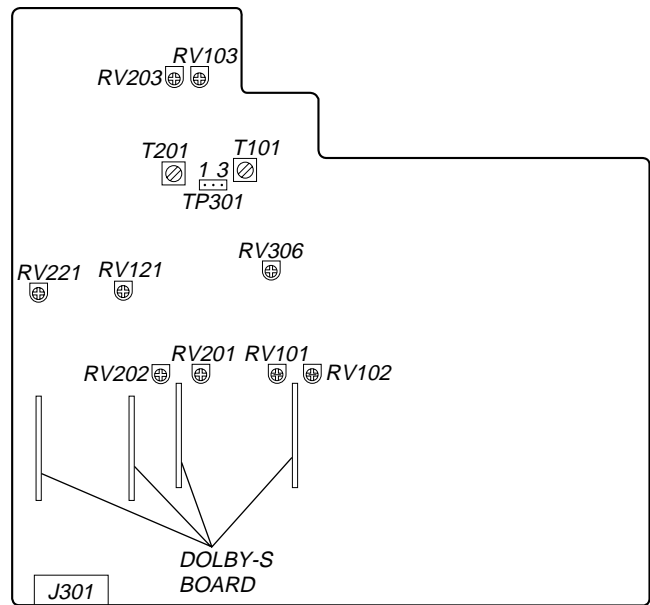

[AUDIO BOARD] – COMPONENT SIDE –

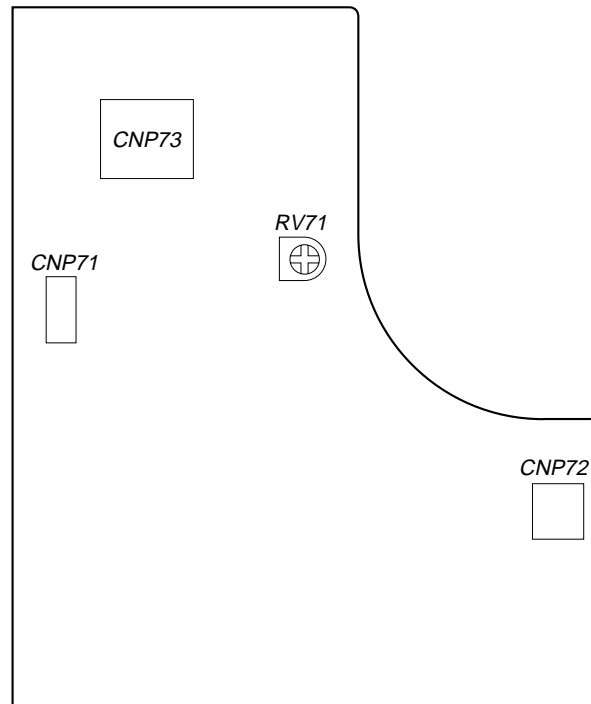

## SECTION 5 DIAGRAMS

### • Circuit Boards Location

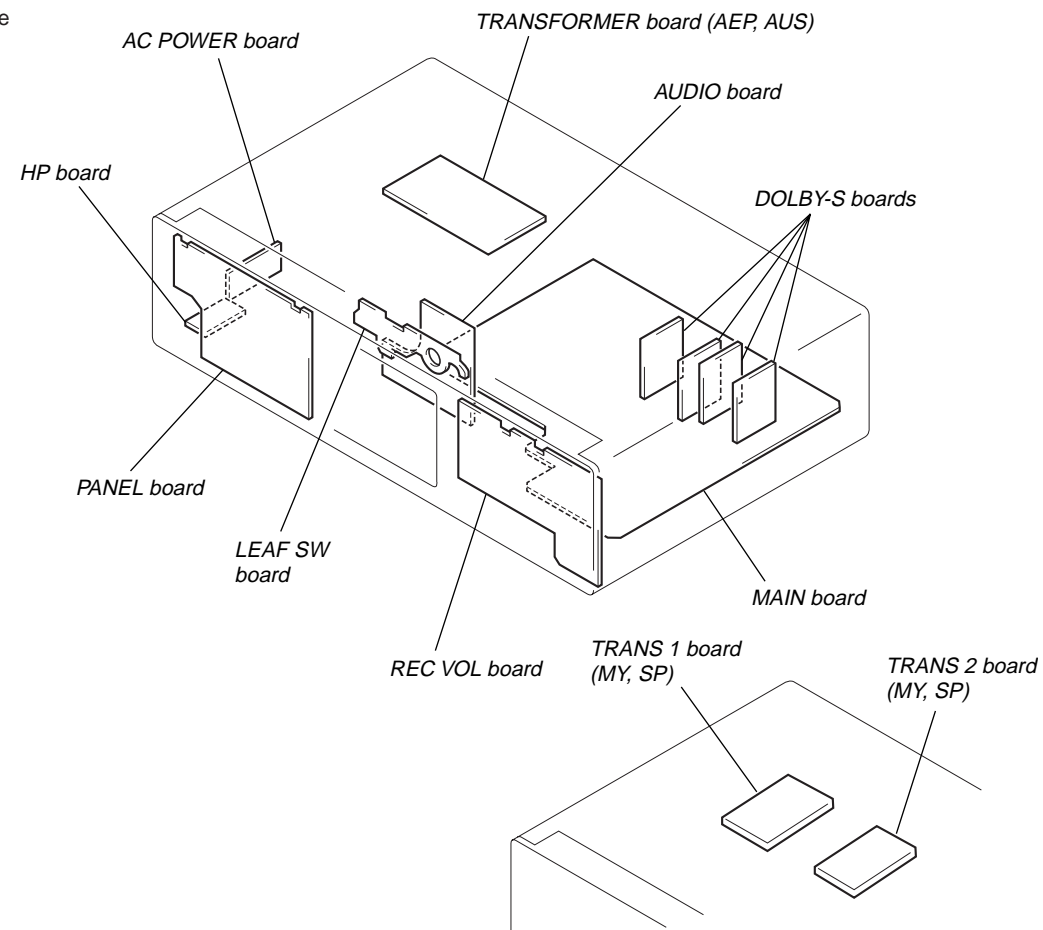

- Abbreviation  
AUS : Australian  
MY : Malaysia  
SP : Singapore







### 5-1. NOTE FOR PRINTED WIRING BOARDS AND SCHEMATIC DIAGRAMS

(In addition to this, the necessary note is each block.)



#### Note on Schematic Diagram:

- All capacitors are in  $\mu\text{F}$  unless otherwise noted.  $\text{pF}$ :  $\mu\text{pF}$  50 WV or less are not indicated except for electrolytics and tantalums.
- All resistors are in  $\Omega$  and  $1/4\text{W}$  or less unless otherwise specified.
- $\Delta$  : internal component.
-  : nonflammable resistor.
-  : fusible resistor.
-  : panel designation.

**Note:** The components identified by mark  $\Delta$  or dotted line with mark  $\Delta$  are critical for safety. Replace only with part number specified.

-  : B+ Line.
-  : B- Line.
-  : adjustment for repair.
- Voltages and waveforms are dc with respect to ground under no-signal conditions.  
no mark : PB  
( ) : REC
- Voltages are taken with a VOM (Input impedance 10 M $\Omega$ ). Voltage variations may be noted due to normal production tolerances.
- Waveforms are taken with a oscilloscope. Voltage variations may be noted due to normal production tolerances.
- Circled numbers refer to waveforms.
- Signal path.  
 : PB  
 : REC
- Abbreviation  
AUS : Australian model.  
MY : Malaysia model.  
SP : Singapore model.

#### Note on Printed Wiring Boards:

-  : parts extracted from the component side.
-  : parts extracted from the conductor side.
-  : Pattern from the side which enables seeing.
- Abbreviation  
AUS : Australian model.  
MY : Malaysia model.  
SP : Singapore model.
- Indication of transistor.

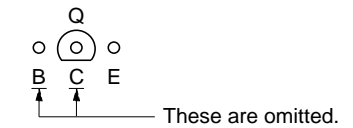
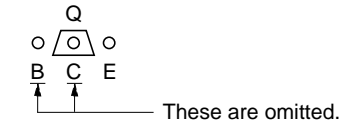

5-2. PRINTED WIRING BOARDS – MD Section – • See page 13 for Circuit Boards Location.

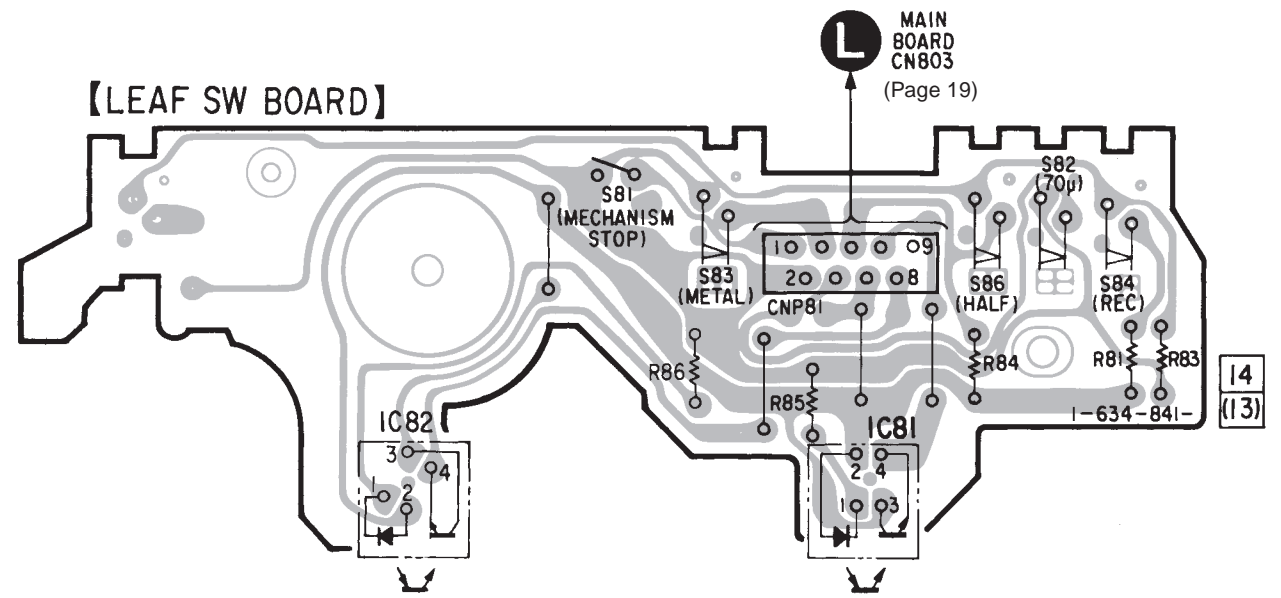
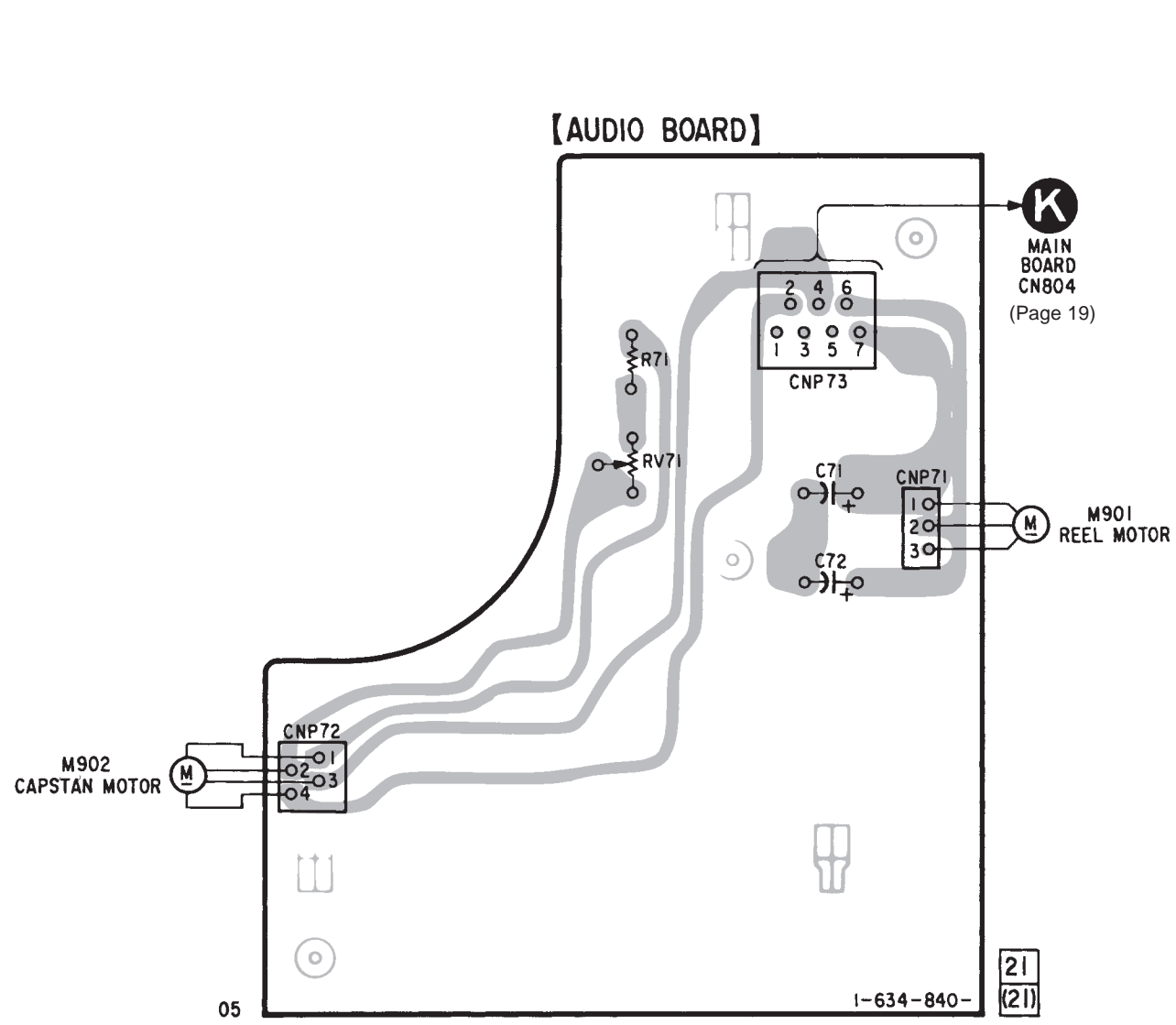

5-3. SCHEMATIC DIAGRAM – MD Section –

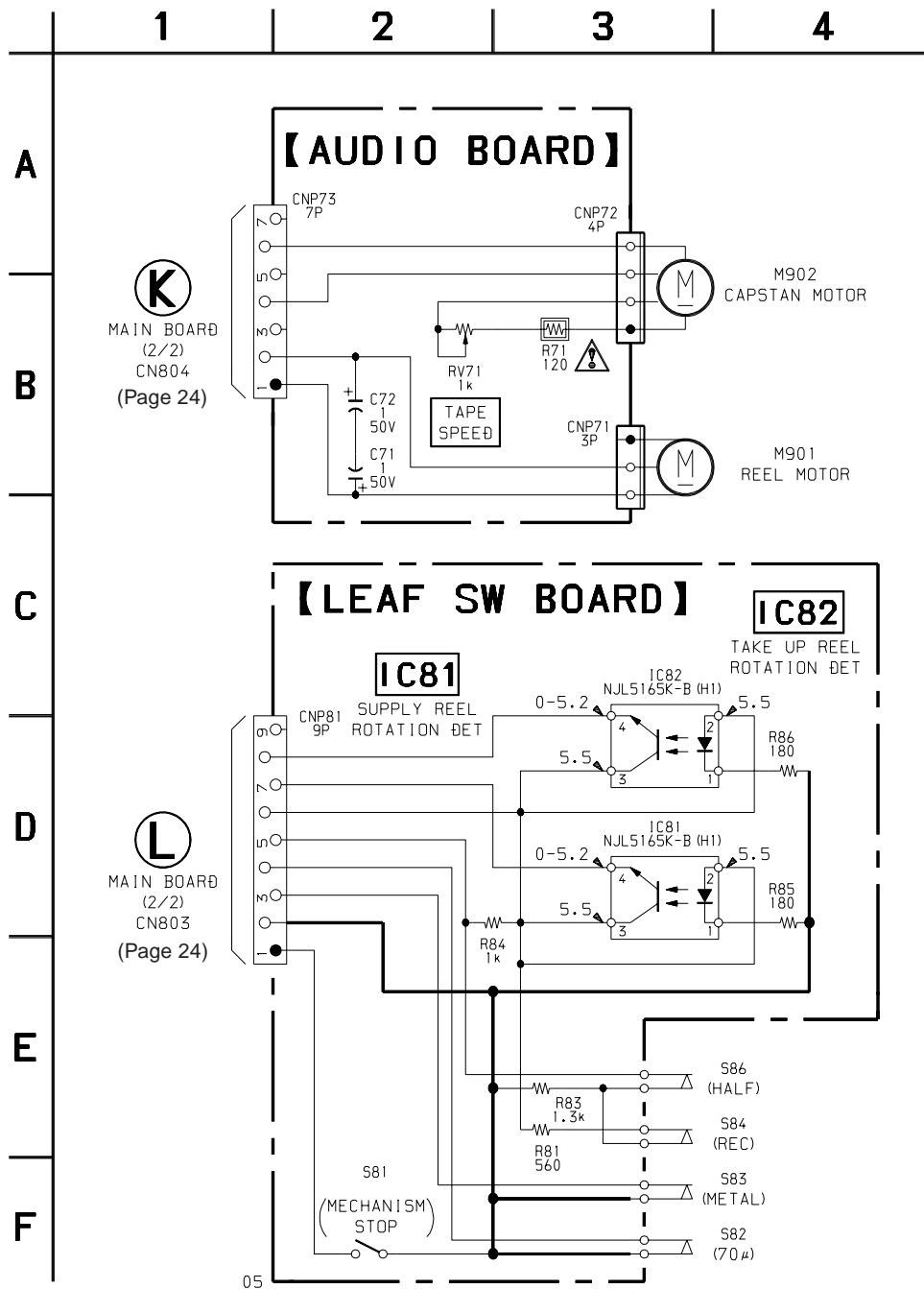

The components identified by mark  $\triangle$  or dotted line with mark  $\triangle$  are critical for safety. Replace only with part number specified.

• Waveforms  
– MAIN BOARD (1/2) –

① T101 ④

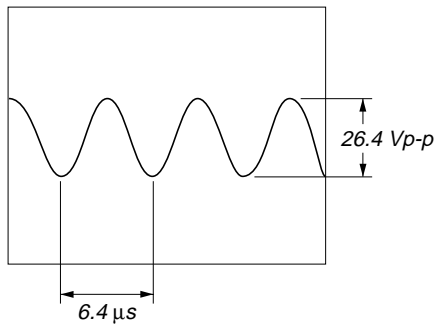

④ IC304 ⑦, ⑧

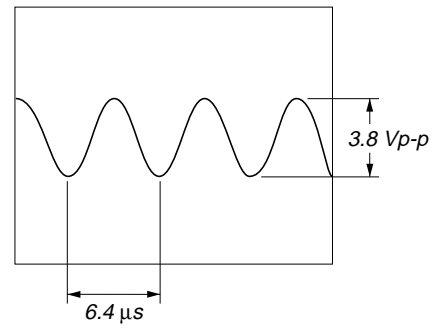

– MAIN BOARD (2/2) –

⑦ IC801 ⑩ (XIN)

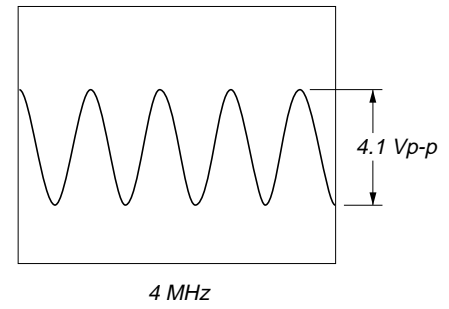

② IC304 ⑪, ⑫

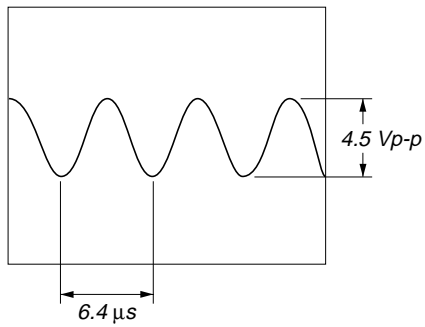

⑤ T301 ①

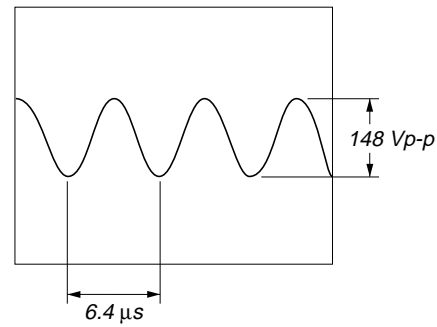

③ T201 ④

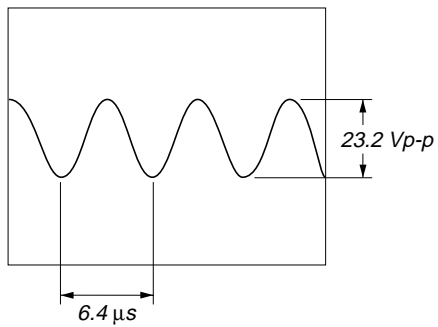

⑥ IQ310 ③, Q311 ③

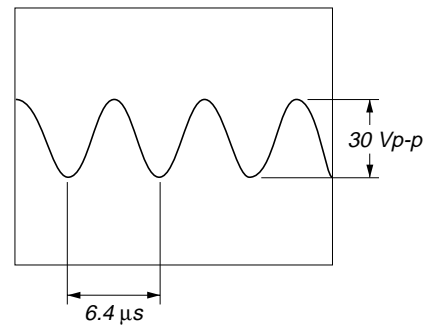

• IC Block Diagram

IC803 BA6219B (MAIN BOARD)

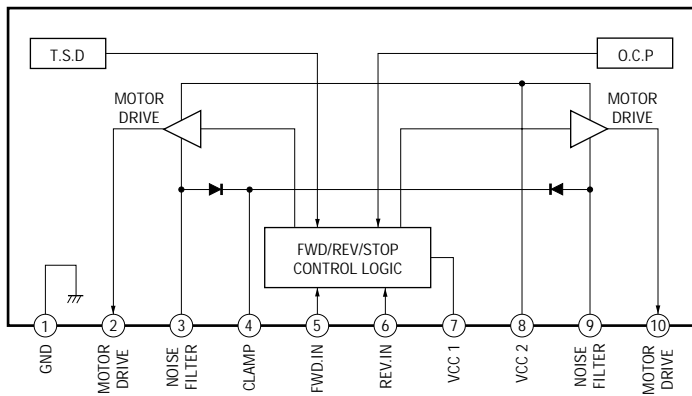



5-4. PRINTED WIRING BOARD – MAIN Section – • See page 13 for Circuit Boards Location.

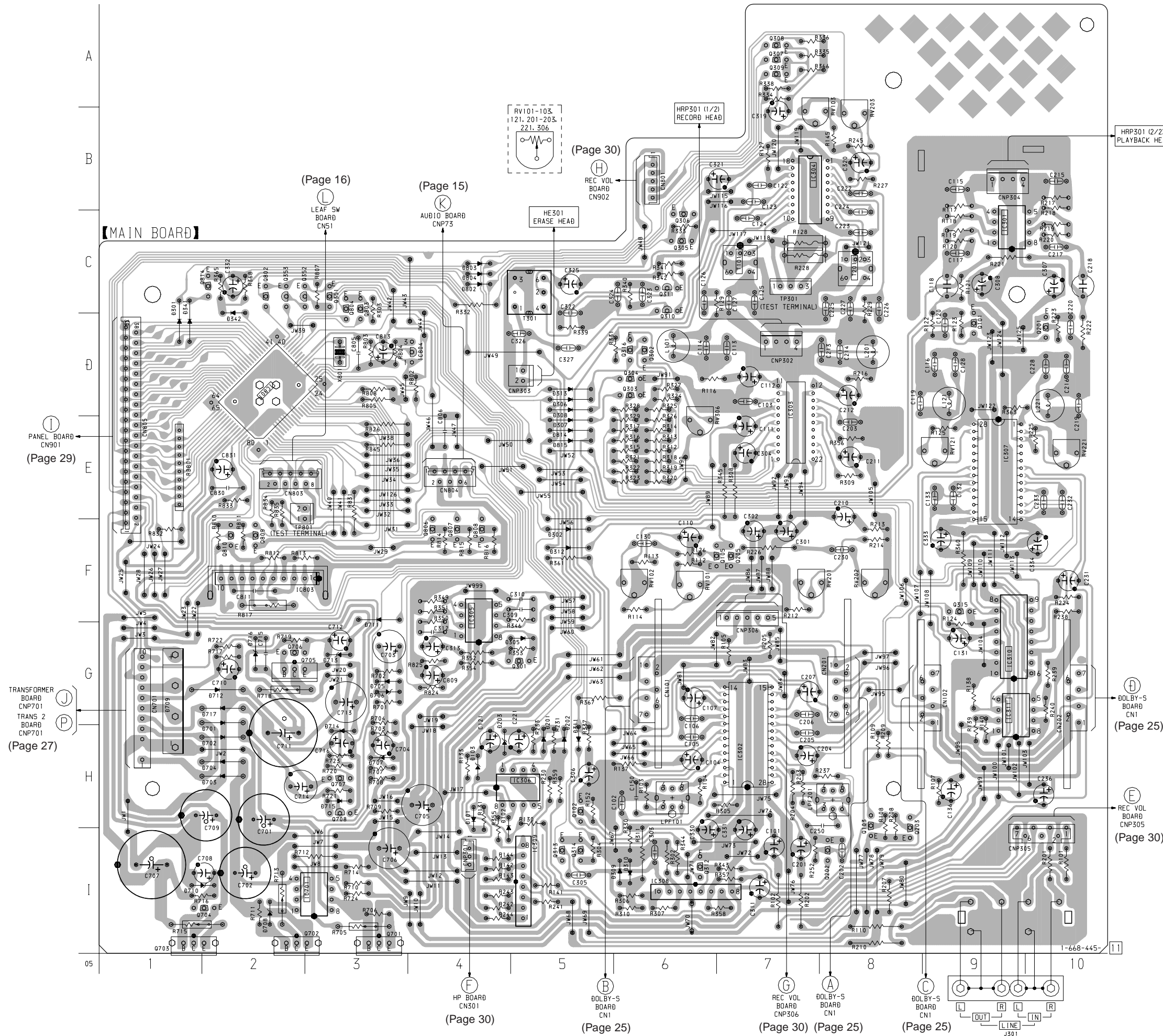

• Semiconductor Location

Ref. No.	Location	Ref. No.	Location
D101	H-4	IC310	G-9
D102	H-4	IC311	G-9
D103	H-4	IC701	I-3
D201	H-5	IC801	D-2
D202	H-5	IC803	F-2
D203	H-4	IC804	D-4
D301	D-1		
D302	F-5	Q101	D-9
D305	G-5	Q102	H-5
D306	D-5	Q103	H-8
D307	E-5	Q105	F-7
D308	D-5	Q201	D-10
D309	I-6	Q202	I-8
D310	I-6	Q203	I-8
D311	H-5	Q205	F-7
D312	F-5	Q301	G-5
D313	D-5	Q302	D-6
D341	D-1	Q303	D-6
D342	D-2	Q304	D-6
D701	G-2	Q305	C-6
D702	H-2	Q306	C-6
D703	H-2	Q307	A-7
D704	H-2	Q308	A-7
D705	G-3	Q309	A-7
D706	G-3	Q310	C-6
D707	H-3	Q311	C-6
D708	I-2	Q312	I-6
D709	G-1	Q313	I-5
D710	I-1	Q314	I-5
D711	F-3	Q315	F-9
D712	G-2	Q316	D-6
D713	G-3	Q351	C-3
D714	H-3	Q352	C-2
D715	H-3	Q353	C-2
D716	G-2	Q701	I-3
D717	G-2	Q702	I-2
D802	C-4	Q703	I-1
D803	C-4	Q704	I-2
D804	C-4	Q705	G-2
D814	E-5	Q706	G-2
D815	E-5	Q707	H-3
		Q708	H-3
IC301	C-9	Q802	C-2
IC302	H-7	Q803	C-3
IC303	E-7	Q804	C-3
IC304	B-7	Q806	F-4
IC305	F-4	Q807	F-4
IC306	H-5	Q808	F-4
IC307	E-9	Q809	F-2
IC308	I-6	Q810	F-2
IC309	I-5	Q814	C-2

The components identified by mark  $\Delta$  or dotted line with mark  $\Delta$  are critical for safety. Replace only with part number specified.

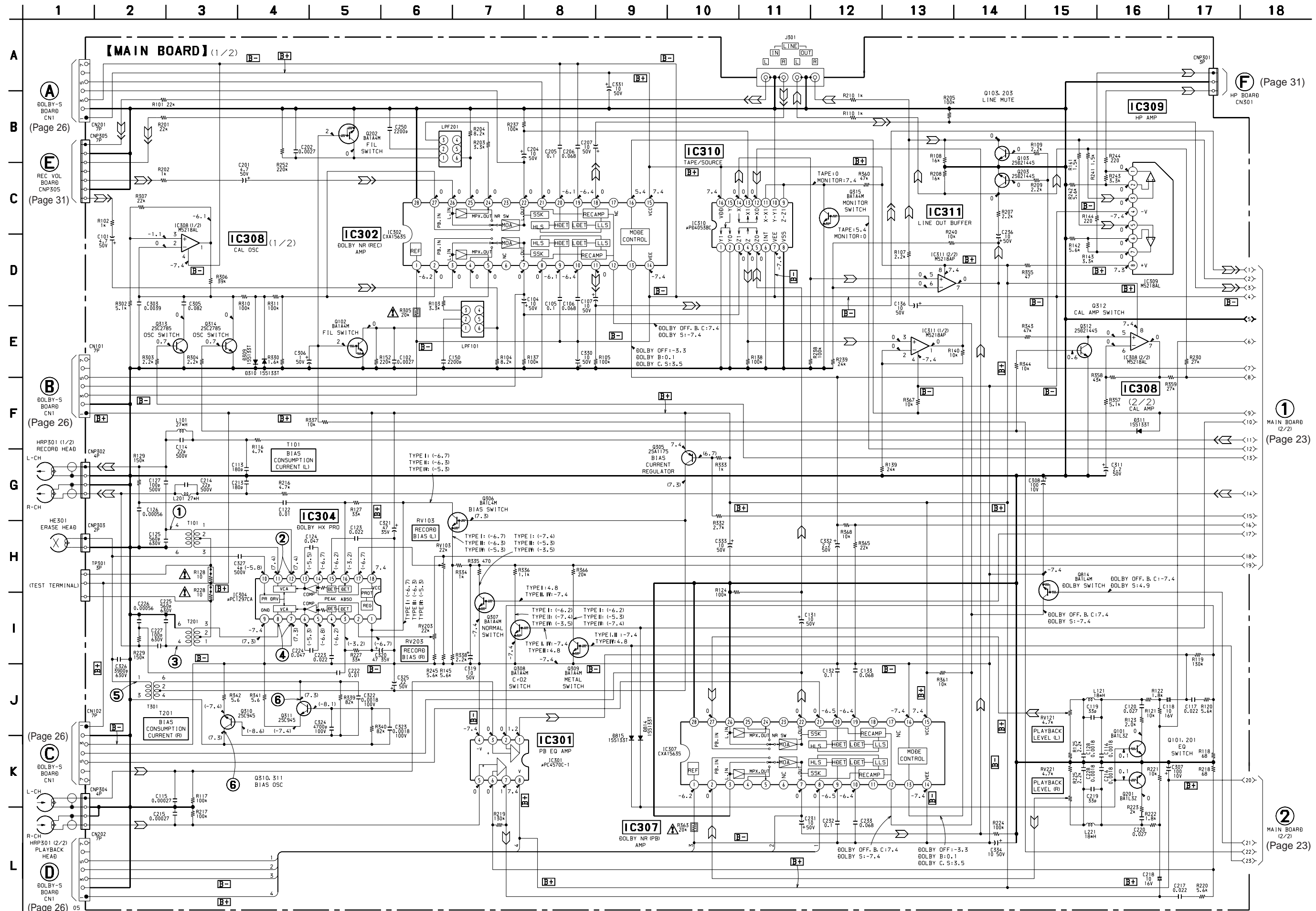





5-9. PRINTED WIRING BOARDS – POWER Section –

• See page 13 for Circuit Boards Location.

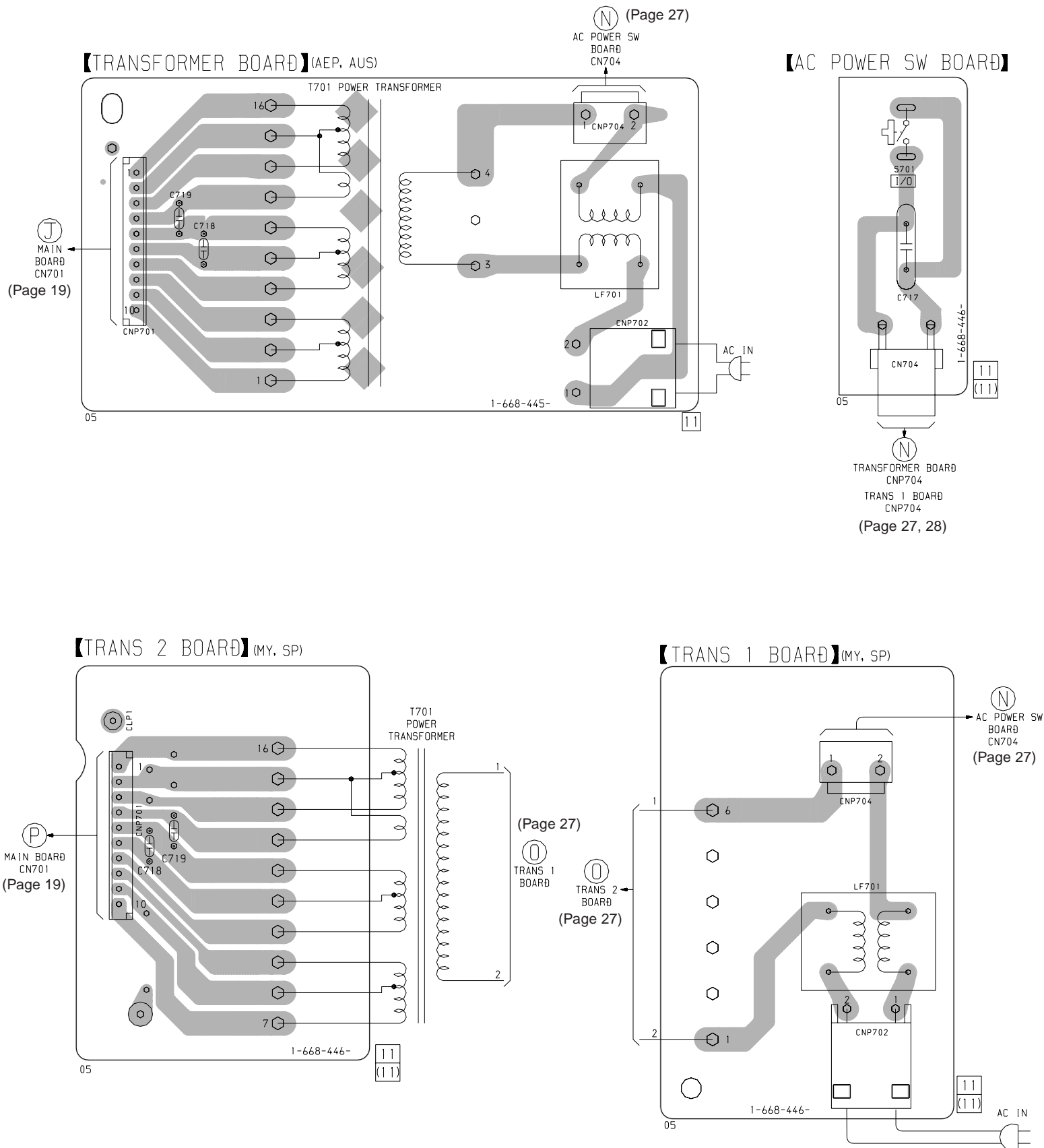

5-10. SCHEMATIC DIAGRAM – POWER Section –

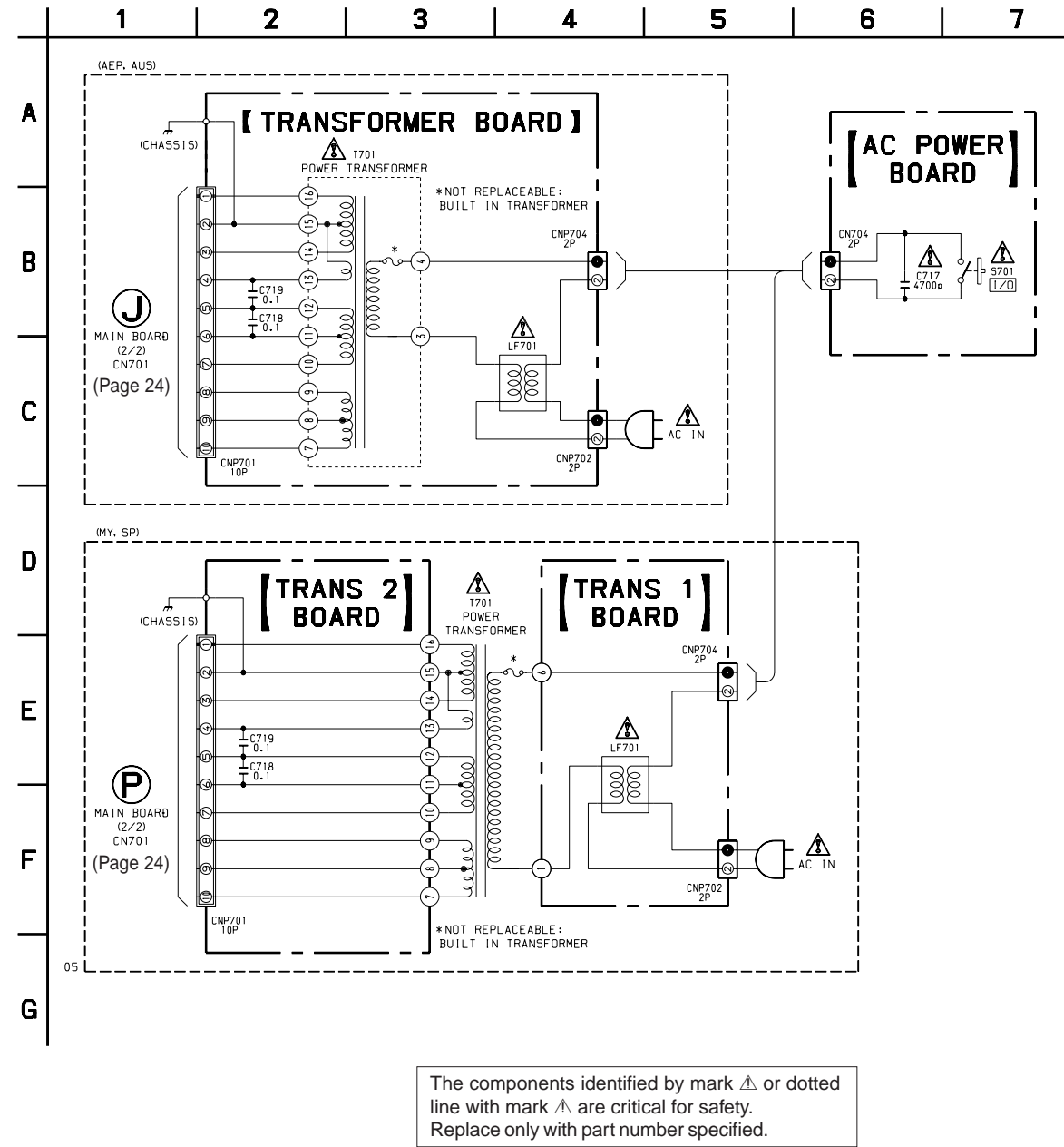

5-11. PRINTED WIRING BOARDS – PANEL Section – • See page 13 for Circuit Boards Location.

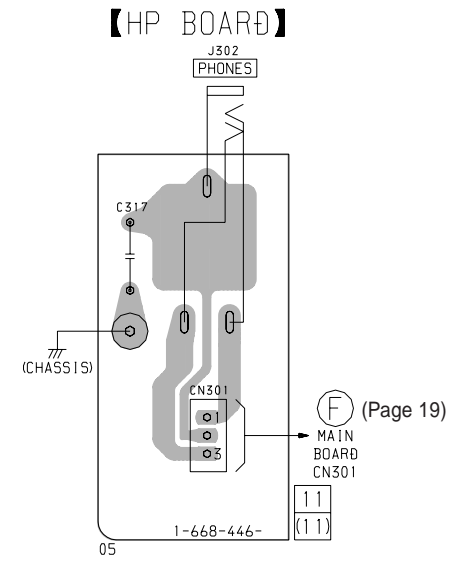
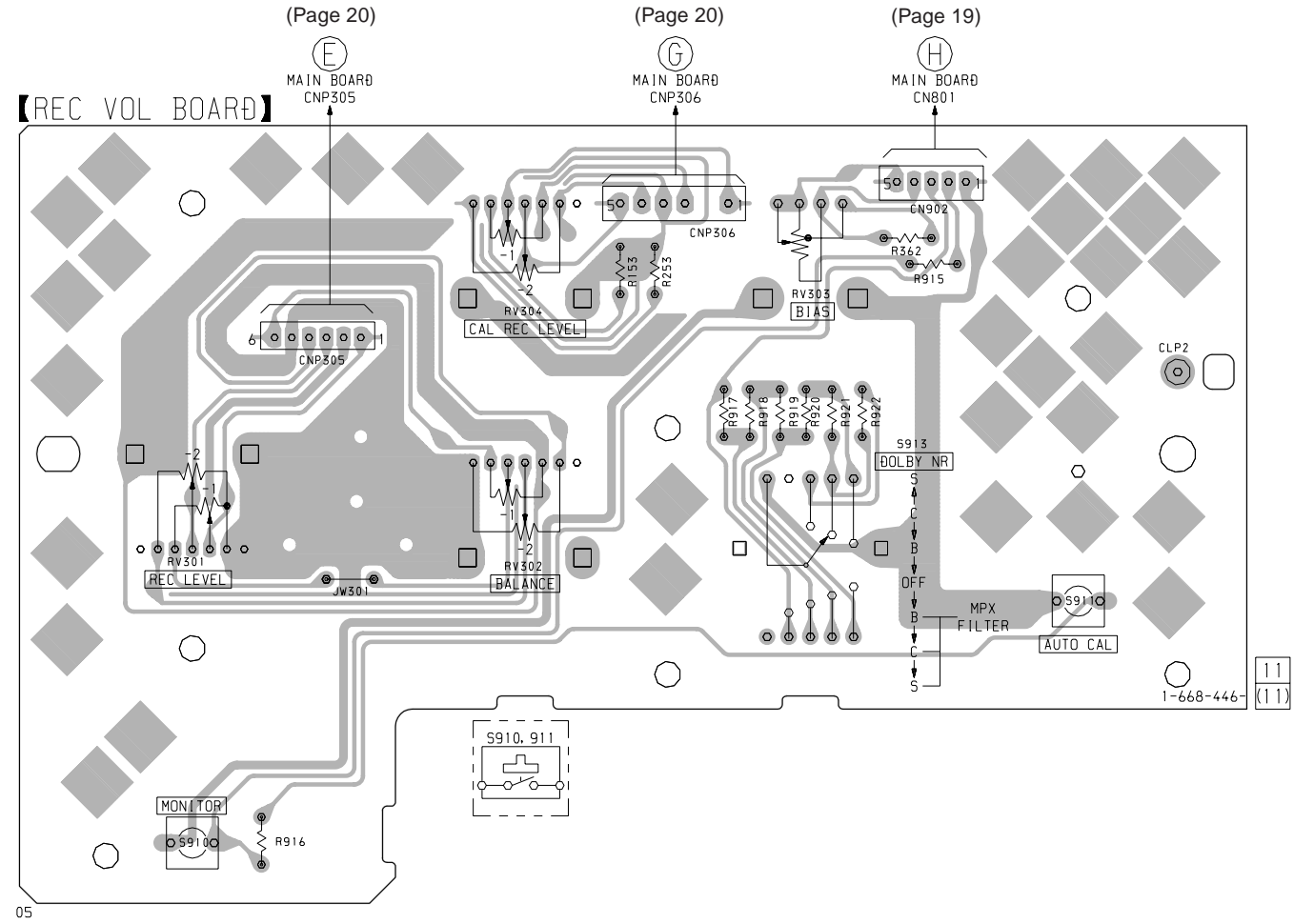
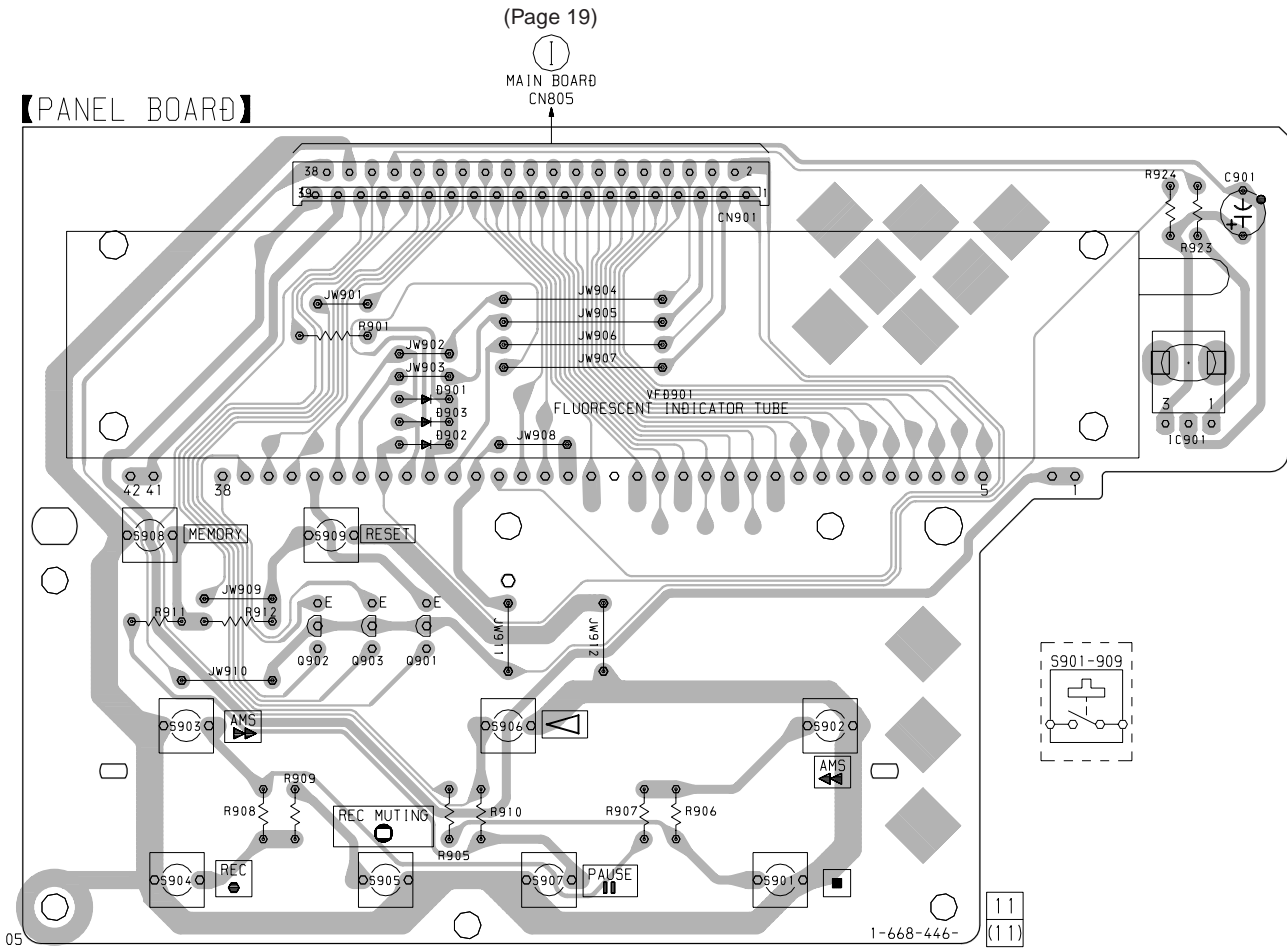

5-12. SCHEMATIC DIAGRAM - PANEL Section -

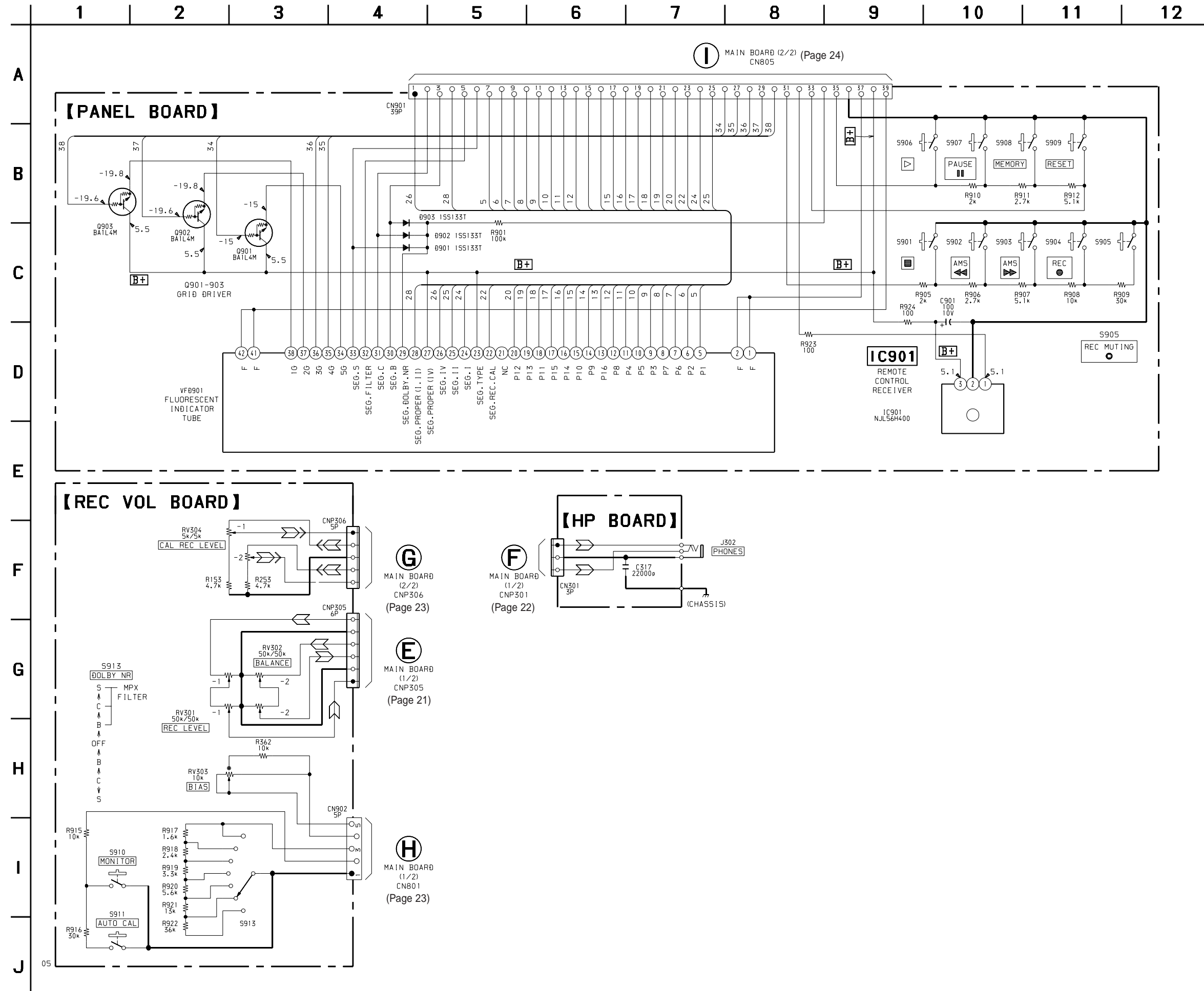

### 5-13. IC PIN FUNCTION DESCRIPTION

#### • MAIN BOARD IC801 M38172M4-171FP (SYSTEM CONTROLLER)

Pin No.	Pin Name	I/O	Function
1	T.REEL	I	Take-up reel rotation pulse input from the rotation detect sensor (IC82)
2	S.REEL	I	Supply reel rotation pulse input from the rotation detect sensor (IC81)
3	METER.LCH	I	Signal input for the level meter drive (L-ch)
4	METER.RCH	I	Signal input for the level meter drive (R-ch)
5	AMS.IN	I	Auto music sensor signal input terminal "H": AMS detect
6	DOOR/STOP.SW	I	Mechanism stop detect switch (S81) input terminal
7	CLOSE.SW	I	Not used (fixed at "H")
8	OPEN.SW	I	Not used (fixed at "H")
9	CAM.SW3	I	Not used (fixed at "H")
10	CAM.SW2	I	Not used (fixed at "H")
11	CAM.SW1	I	Not used (fixed at "H")
12	CAM.SW0	I	Not used (fixed at "H")
13	CAP.M ON/OFF	O	Capstan motor (M902) on/off control signal output terminal "H": motor on
14	ASIST.M.UP	O	Assist motor drive signal output terminal Not used (pull down)
15	ASIST.M.DOWN	O	Assist motor drive signal output terminal Not used (pull down)
16	REEL.M.FWD	O	Reel motor (M901) drive signal output to the BA6219B (IC803)
17	REEL.M.REV	O	Reel motor (M901) drive signal output to the BA6219B (IC803)
18	EJECT.V (6.5V)	O	Reel motor (M901) eject control signal output terminal "H" active
19	FF/REW.V (4.4V)	O	Reel motor (M901) FF/REW control signal output terminal "H" active
20	PLAY.V (2.5V)	O	Reel motor (M901) play control signal output terminal "H" active
21	TYPE.IV	I	Metal detect switch (S83) input terminal "H": metal
22	HALF.SW	I	Half detect switch input terminal Not used (fixed at "H")
23	TYPE.II	I	CrO <sub>2</sub> detect switch (S82) input terminal "H": CrO <sub>2</sub>
24	TAB.SW	I	Not used (fixed at "H")
25	POWER.IN	I	AC in detect signal input terminal "H": AC in
26	SIRCS.IN	I	Sircs signal input from the remote control receiver (IC901)
27	RESET	I	System reset signal input from the reset signal generator (IC804) "L": reset "L" is input for several 100 msec after power on, then it changes to "H"
28	XCIN	I	Sub system clock input terminal Not used (fixed at "L")
29	XCOU	O	Sub system clock output terminal Not used (open)
30	XIN	I	Main system clock input terminal (4 MHz)
31	XOUT	O	Main system clock output terminal (4 MHz)
32	VSS	—	Ground terminal
33	VER.200/190	I	Setting terminal for the version (fixed at "L")
34	POWER.OUT	O	Power on/off control signal output terminal "L": power on Not used (open)
35	MONITOR.TAPE/ SOURCE	O	Audio monitor selection signal output terminal "H": tape monitor, "L": source monitor
37	OSC H/L	O	Calibration tone frequency high/low control signal output terminal "L": frequency low
38	CAL.ON/OFF	O	Calibration tone on/off control signal output terminal "H": on, "L": off
39	REC.M.ON/OFF	O	Record muting on/off control signal output to the CXA1598S (IC303) "L": record muting on
40	BIAS.ON/OFF	O	Recording bias on/off control signal output terminal "H": bias on
41	DOL.CON	O	Dolby B/C type or dolby on/off selection signal output to the CXA1563S (IC302, 307) "H": dolby C type, "L": dolby off (center voltage: dolby B type)
42	SEG.IV	O	Metal on/off control signal output or segment drive signal output to the fluorescent indicator tube (VFD901) (for TYPE IV light up)

Pin No.	Pin Name	I/O	Function
43	SEG.DOL.C	O	Segment drive signal output to the fluorescent indicator tube (VFD901) (for DOLBY NR C light up)
44	SEG.DOL.B	O	Segment drive signal output to the fluorescent indicator tube (VFD901) (for DOLBY NR B light up)
45	SEG.PROPER	O	Segment drive signal output to the fluorescent indicator tube (VFD901) (for TYPE I, II light up)
46	SEG.FIL.ON/OFF	O	Multiplex filter on/off control signal output or segment drive signal output to the fluorescent indicator tube (VFD901) (for FILTER light up) "H": multiplex filter on
47	SEG.DOL.S. ON/OFF	O	Dolby S type on/off selection signal output to the CXA1563S (IC302, 307) or segment drive signal output to the fluorescent indicator tube (VFD901) (for DOLBY NR S light up) "L": dolby S on
48	NC	O	Not used (open)
49	SEG01	O	Segment drive signal output to the fluorescent indicator tube (VFD901)
50	SEG02	O	
51	SEG06	O	
52	SEG07	O	
53	SEG03	O	
54	SEG05	O	
55	SEG04	O	
56	SEG08	O	
57	SEG16	O	
58	SEG09	O	
59	SEG10	O	
60	SEG14	O	
61	SEG15	O	
62	SEG11	O	
63	SEG13	O	
64	SEG12	O	
65	SEG.CAL	O	
66	SEG.I	O	Recording equalizer type I select signal output or segment drive signal output to the fluorescent indicator tube (VFD901) (for TYPE I light up)
67	SEG.II	O	Recording equalizer type II select signal output or segment drive signal output to the fluorescent indicator tube (VFD901) (for TYPE II light up)
68	G5-DISPLAY	O	Grid drive signal output to the fluorescent indicator tube (VFD901)
69	G4-SEC	O	
70	G3-MIN	O	
71	G2-RCH	O	
72	G1-LCH	O	
73	VCC	—	Power supply terminal (+5V)
74	VEE	—	Power supply terminal (–24V)
75	AVSS	—	Ground terminal (for A/D converter)
76	VREF	I	Reference voltage (+5V) input terminal
77	KEY2	I	Key input terminal (A/D input) (S906 to S909) ▷, ■ PAUSE, MEMORY, RESET keys input
78	KEY1	I	Key input terminal (A/D input) (S901 to S905) ■, AMS ◀, AMS ▶, ● REC, ○ REC MUTING keys input
79	TIMER.SW	I	Half detect switch (S86) input terminal
80	DOLBY.SW	I	DOLBY NR switch (S913) input terminal (A/D input)





## (2) FRONT PANEL SECTION

- D: AC POWER BOARD
- E: HP BOARD
- F: REC VOL BOARD

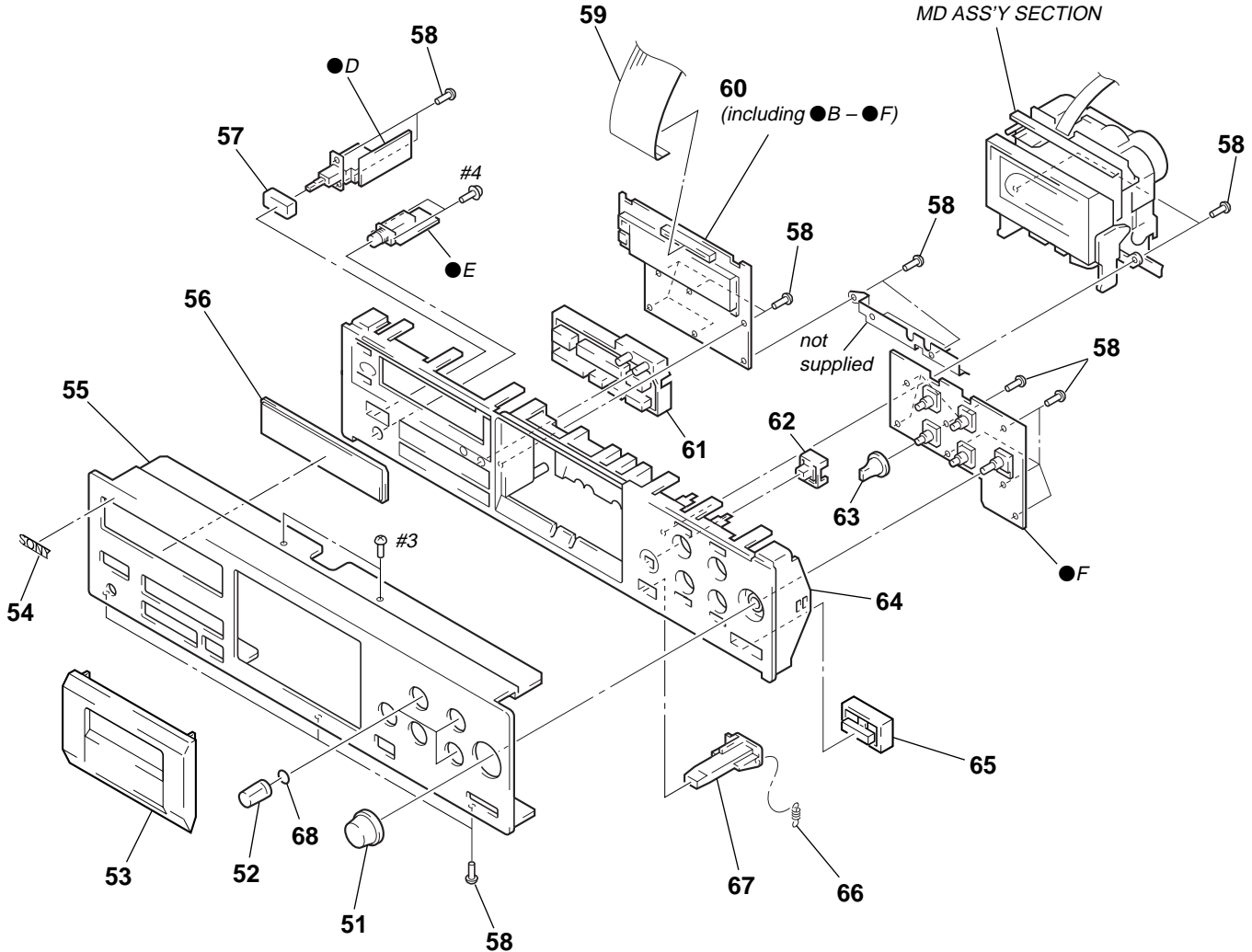

Ref. No.	Part No.	Description	Remark	Ref. No.	Part No.	Description	Remark
51	3-020-978-01	KNOB (REC)(BLACK)		* 60	A-2007-777-A	PANEL BOARD, COMPLETE (MY,SP)	
51	3-020-978-11	KNOB (REC)(SILVER)		61	3-020-975-01	BUTTON (CONTROL)(BLACK)	
52	3-020-979-01	KNOB (BALANCE)(BLACK)		61	3-020-975-11	BUTTON (CONTROL)(SILVER)	
52	3-020-979-11	KNOB (BALANCE)(SILVER)		62	3-020-977-01	BUTTON (AUTO CAL)(BLACK)	
53	X-3374-954-1	LID ASSY, CASSETTE (BLACK)		62	3-020-977-11	BUTTON (AUTO CAL)(SILVER)	
53	X-3375-905-1	LID ASSY, CASSETTE (SILVER)		63	3-933-299-01	KNOB (DIA. 12)(BLACK)	
54	4-942-568-41	EMBLEM (NO.5), SONY		63	3-933-299-11	KNOB (DIA. 12)(SILVER)	
55	3-020-971-11	PANEL, FRONT (BLACK)(AEP)		64	X-3375-507-1	BASE (KB920S) ASSY, PANEL(BLACK)	
55	3-020-971-31	PANEL, FRONT (MY,SP,AUS)		64	X-3375-906-1	BASE (KB920S) ASSY, PANEL(SILVER)	
55	3-020-971-41	PANEL, FRONT (SILVER)(AEP)		65	3-933-296-01	BUTTON (MONITOR)(BLACK)	
56	3-020-980-01	WINDOW (METER)		65	3-933-296-11	BUTTON (MONITOR)(SILVER)	
57	4-922-921-62	BUTTON (POWER)(BLACK)		66	3-937-169-01	SPRING, TENSION	
57	4-922-921-91	BUTTON (POWER)(SILVER)		67	3-020-976-01	BUTTON (EJECT)(BLACK)	
58	4-951-620-01	SCREW (2.6X8), +BVTP		67	3-020-976-11	BUTTON (EJECT)(SILVER)	
59	1-777-109-11	WIRE (FLAT TYPE) (39 CORE)		68	3-354-981-11	SPRING (SUS), RING	
* 60	A-2007-775-A	PANEL BOARD, COMPLETE (AEP,AUS)					

**(3) MD ASS'Y SECTION**

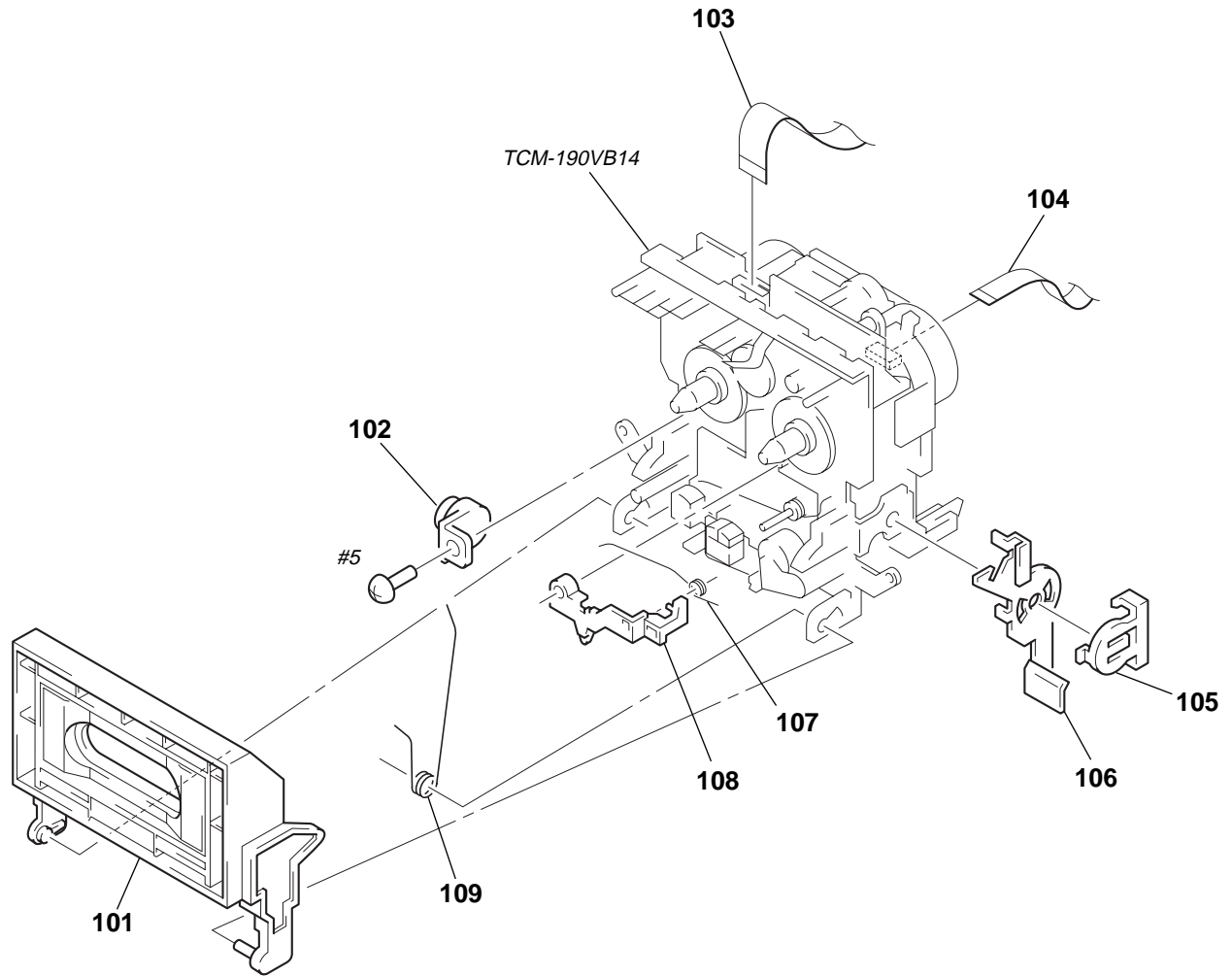

<u>Ref. No.</u>	<u>Part No.</u>	<u>Description</u>	<u>Remark</u>	<u>Ref. No.</u>	<u>Part No.</u>	<u>Description</u>	<u>Remark</u>
101	X-3368-119-1	HOLDER (R) ASSY, CASSETTE		* 106	3-354-954-01	LEVER (LOCK LEVER R)	
102	3-354-963-01	DAMPER		107	3-354-962-01	SPRING (EJ SAFTY SPRING R)	
103	1-769-915-11	WIRE (FLAT TYPE)(9 CORE)		108	3-354-956-01	LEVER (EJ SAFTY LEVER R)	
104	1-765-314-11	WIRE (FLAT TYPE)(7 CORE)		109	3-354-960-01	SPRING (LOADING R), TORSION	
105	3-354-957-01	JOINT (LOCK LEVER)					

**(4) MECHANISM DECK SECTION-1  
(TCM-190VB14)**

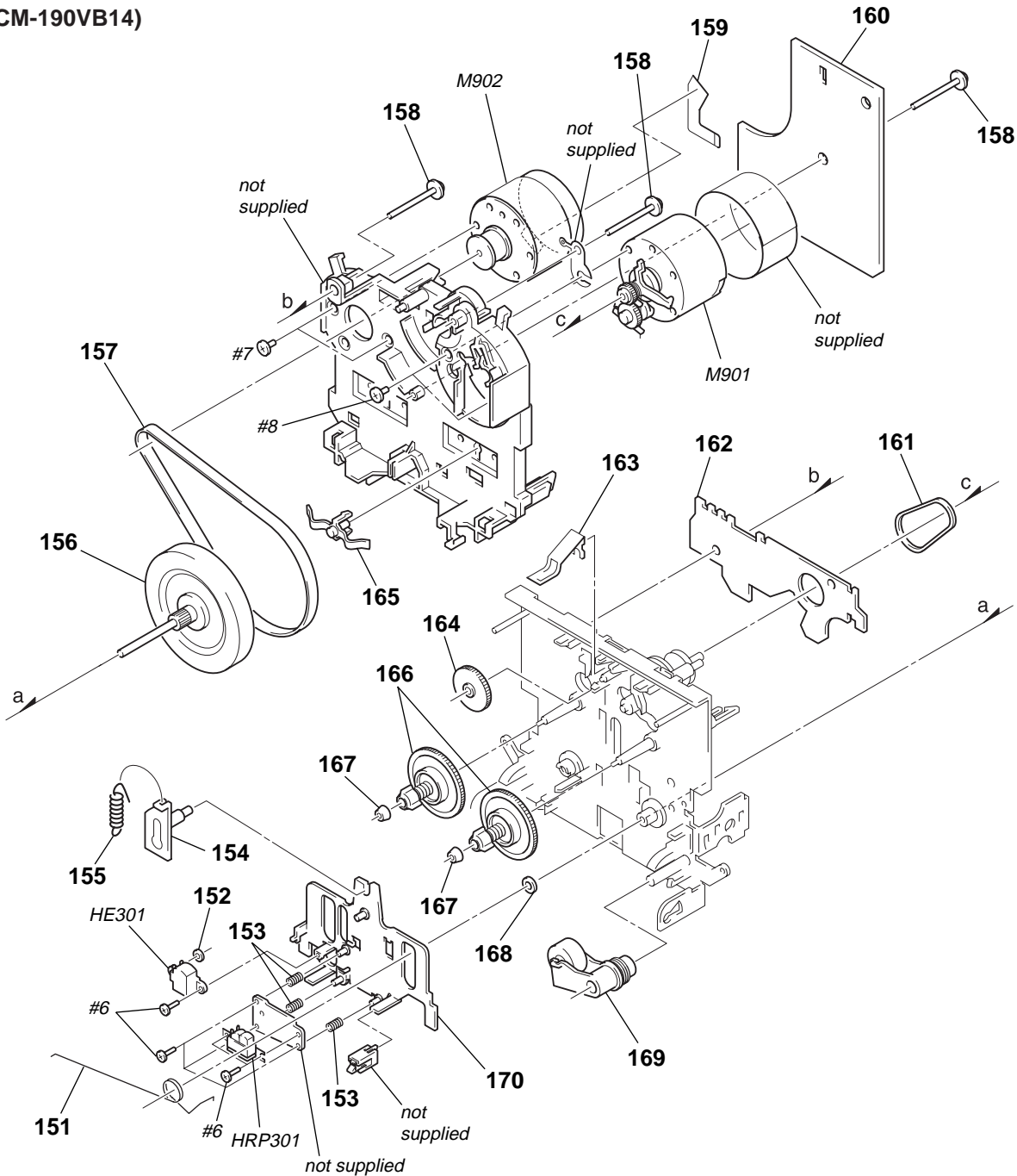

Ref. No.	Part No.	Description	Remark	Ref. No.	Part No.	Description	Remark
151	3-911-014-01	SPRING, TORSION		163	3-359-430-01	SPRING(CASSETTE RETAINER),LEAF	
152	3-701-437-01	WASHER		164	3-359-424-01	GEAR (REV GEAR)	
153	3-356-659-11	SPRING (RPH), COMPRESSION		165	3-575-321-00	RETAINER, THRUST, CAPSTAN	
* 154	X-3374-992-1	SLIDER (LIMITER) ASSY		166	X-3366-971-1	TABLE ASSY (B), REEL	
155	3-363-868-01	SPRING (HEAD CHASSIS), TENSION		167	3-362-308-01	CAP (REEL)	
156	X-3368-368-1	FLYWHEEL (FWD) COMPLETE ASSY		168	3-356-713-01	WASHER	
157	3-937-332-01	BELT (CAPSTAN)		169	X-3366-047-1	LEVER (PINCH F) ASSY	
158	3-359-414-01	SCREW (+PTPWH 2X23)		* 170	X-3369-024-1	SLIDER (HEAD CHASSIS) ASSY	
159	1-638-983-11	MOTOR FLEXIBLE BOARD		HE301	1-543-673-11	HEAD, MAGNETIC (ERASE)	
* 160	1-634-840-21	AUDIO BOARD		HRP301	1-543-733-11	HEAD,MAGNETIC (RECORD/PLAYBACK)	
161	3-359-466-01	BELT (FR), SQUARE		M901	X-3363-501-2	MOTOR ASSY (REEL)	
* 162	1-634-841-14	LEAF SW BOARD		M902	X-3374-302-1	MOTOR ASSY (CAPSTAN)	

**(5) MECHANISM DECK SECTION-2  
(TCM-190VB14)**

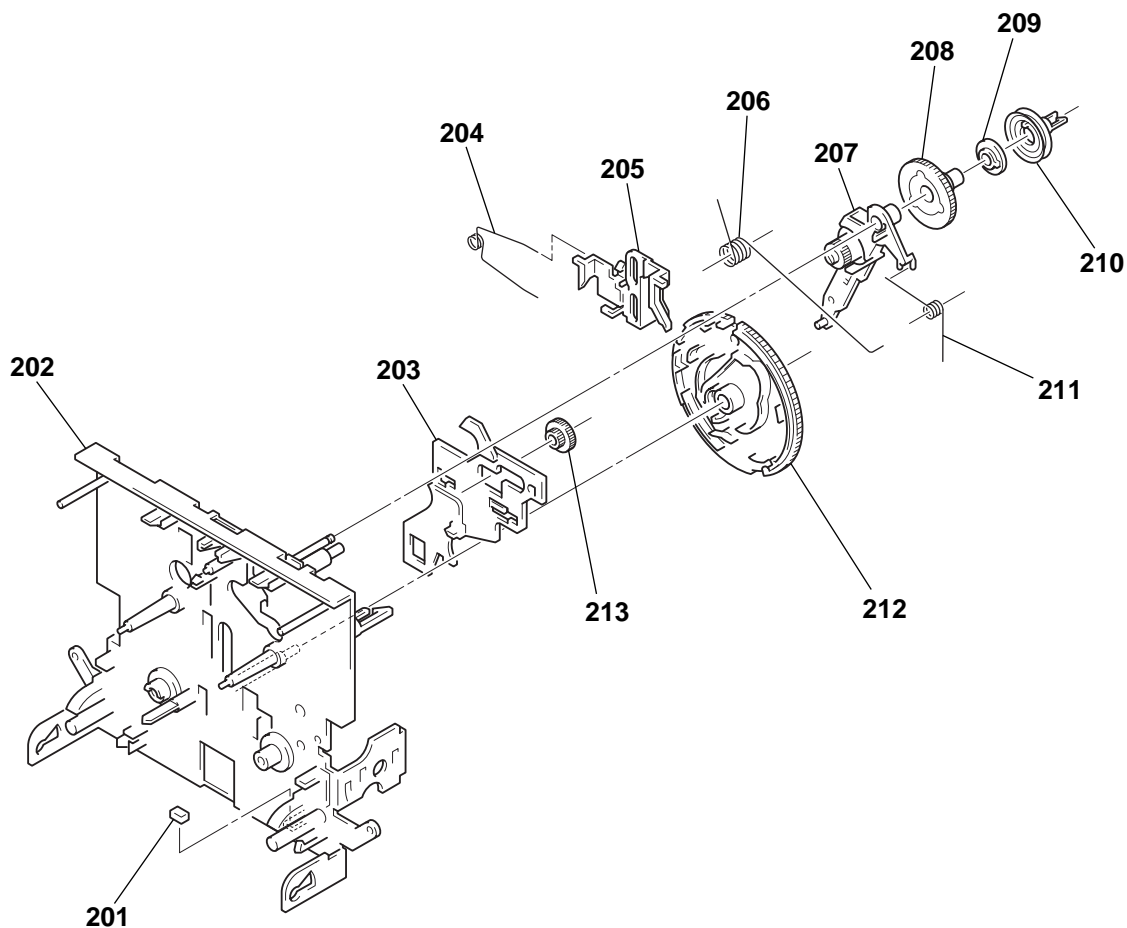

<u>Ref. No.</u>	<u>Part No.</u>	<u>Description</u>	<u>Remark</u>	<u>Ref. No.</u>	<u>Part No.</u>	<u>Description</u>	<u>Remark</u>
201	3-359-469-01	SPACER		208	3-359-419-11	GEAR (FR GEAR)	
202	X-3368-719-2	CHASSIS(ONE)ASSY, MECHANICAL		209	3-359-421-01	CLUTCH (REEL DISK)	
203	3-359-415-11	SLIDER (TRIGGER SLIDER)		210	3-359-418-01	PULLEY (FR PULLEY)	
204	3-359-454-01	SPRING, TORSION		211	3-924-185-11	SPRING (FR ARM), TORSION	
205	3-359-429-11	SLIDER (BRAKE PLATE)		212	3-936-483-01	GEAR (CAM GEAR)	
206	3-359-456-01	SPRING(TRIGGER SPRING),TORSION		213	3-359-448-01	GEAR (TRIGGER)	
207	X-3366-569-1	ARM ASSY, FR					

# AC POWER SW

## AUDIO

## DOLBY-S

# SECTION 7 ELECTRICAL PARTS LIST

### NOTE:

- Due to standardization, replacements in the parts list may be different from the parts specified in the diagrams or the components used on the set.
- -XX and -X mean standardized parts, so they may have some difference from the original one.
- RESISTORS  
All resistors are in ohms.  
METAL: Metal-film resistor.  
METAL OXIDE: Metal oxide-film resistor.  
F: nonflammable
- Abbreviation  
AUS : Australian  
MY : Malaysia  
SP : Singapore

- Items marked “\*” are not stocked since they are seldom required for routine service. Some delay should be anticipated when ordering these items.
- SEMICONDUCTORS  
In each case, u:  $\mu$ , for example:  
uA. . :  $\mu$ A. .      uPA. . :  $\mu$ PA. .  
uPB. . :  $\mu$ PB. .    uPC. . :  $\mu$ PC. .  
uPD. . :  $\mu$ PD. .
- CAPACITORS  
uF:  $\mu$ F
- COILS  
uH:  $\mu$ H

The components identified by mark  $\Delta$  or dotted line with mark  $\Delta$  are critical for safety. Replace only with part number specified.

When indicating parts by reference number, please include the board.

Ref. No.	Part No.	Description	Remark	Ref. No.	Part No.	Description	Remark
		AC POWER SW BOARD ***** (Included in PANEL BOARD, COMPLETE)					
		< CAPACITOR >					
$\Delta$ C717	1-117-703-11	CERAMIC	0.0047uF 99% 250V	C6	1-136-165-00	FILM	0.1uF 5% 50V
		< CONNECTOR >		C7	1-137-372-11	FILM	0.022uF 5% 50V
CN704	1-568-226-11	PIN, CONNECTOR 2P		C8	1-164-222-11	CERAMIC CHIP	0.22uF 25V
		< SWITCH >		C9	1-126-301-11	ELECT	1uF 20% 50V
$\Delta$ S701	1-762-581-11	SWITCH, AC POWER PUSH (1 KEY) (I/O)		C10	1-137-442-11	FILM	0.039uF 5% 50V
		*****		C11	1-163-007-11	CERAMIC CHIP	680PF 10% 50V
*	1-634-840-21	AUDIO BOARD *****		C12	1-164-717-11	CERAMIC CHIP	0.0082uF 5% 50V
		< CAPACITOR >		C13	1-163-038-00	CERAMIC CHIP	0.1uF 25V
C71	1-124-903-11	ELECT	1uF 20% 50V	C14	1-124-465-00	ELECT	0.47uF 20% 50V
C72	1-124-903-11	ELECT	1uF 20% 50V	C15	1-164-222-11	CERAMIC CHIP	0.22uF 25V
		< CONNECTOR >		C16	1-163-038-00	CERAMIC CHIP	0.1uF 25V
* CNP71	1-564-705-11	PIN, CONNECTOR (SMALL TYPE) 3P		C17	1-124-465-00	ELECT	0.47uF 20% 50V
CNP72	1-764-902-11	CONNECTOR, FFC/FPC 4P		C18	1-163-038-00	CERAMIC CHIP	0.1uF 25V
* CNP73	1-568-826-11	SOCKET, CONNECTOR 7P		C19	1-164-222-11	CERAMIC CHIP	0.22uF 25V
		< RESISTOR >		C20	1-163-035-00	CERAMIC CHIP	0.047uF 50V
$\Delta$ R71	1-249-406-11	CARBON	120 5% 1/4W F	C21	1-164-717-11	CERAMIC CHIP	0.0082uF 5% 50V
		< VARIABLE RESISTOR >		C22	1-164-161-11	CERAMIC CHIP	0.0022uF 10% 100V
RV71	1-241-761-11	RES, ADJ, CARBON 1K		C23	1-163-005-11	CERAMIC CHIP	470PF 10% 50V
		*****		C24	1-137-442-11	FILM	0.039uF 5% 50V
*	A-2007-481-A	DOLBY-S BOARD, COMPLETE *****		C25	1-136-165-00	FILM	0.1uF 5% 50V
		< CAPACITOR >		C26	1-137-372-11	FILM	0.022uF 5% 50V
C1	1-136-165-00	FILM	0.1uF 5% 50V	C28	1-163-038-00	CERAMIC CHIP	0.1uF 25V
C2	1-163-012-00	CERAMIC CHIP	0.0018uF 10% 50V			< CONNECTOR >	
C3	1-163-012-00	CERAMIC CHIP	0.0018uF 10% 50V	CN1	1-695-092-11	SOCKET, CONNECTOR 7P	
C4	1-164-222-11	CERAMIC CHIP	0.22uF 25V			< IC >	
C5	1-136-165-00	FILM	0.1uF 5% 50V	IC1	8-752-076-30	IC CXA1917AM-T6	
						< SHORT CHIP >	
				J1	1-216-296-00	SHORT (CHIP) 0	
				J2	1-216-296-00	SHORT (CHIP) 0	
				J3	1-216-296-00	SHORT (CHIP) 0	
						< RESISTOR >	
				R1	1-216-685-11	METAL CHIP	27K 0.5% 1/10W
				R2	1-208-811-11	RES,CHIP	16K 2% 1/10W
				R3	1-208-791-11	RES,CHIP	2.4K 2% 1/10W
				R4	1-208-799-11	RES,CHIP	5.1K 2% 1/10W
				R5	1-216-689-11	METAL CHIP	39K 0.5% 1/10W

Ref. No.	Part No.	Description	Remark	Ref. No.	Part No.	Description	Remark
R6	1-216-689-11	METAL CHIP	39K 0.5% 1/10W				
R7	1-216-615-11	METAL CHIP	33 0.5% 1/10W				
R8	1-208-462-41	RES.CHIP	10K 2% 1/10W				
R9	1-208-812-11	RES.CHIP	18K 2% 1/10W				
R10	1-216-615-11	METAL CHIP	33 0.5% 1/10W				
R11	1-216-619-11	METAL CHIP	47 0.5% 1/10W				
R12	1-216-684-11	METAL CHIP	24K 0.5% 1/10W				
R13	1-216-615-11	METAL CHIP	33 0.5% 1/10W				
R14	1-216-619-11	METAL CHIP	47 0.5% 1/10W				
R15	1-216-655-11	METAL CHIP	1.5K 0.5% 1/10W				
R16	1-216-678-11	METAL CHIP	13K 0.5% 1/10W				
R17	1-216-673-11	METAL CHIP	8.2K 0.5% 1/10W				
R18	1-208-462-41	RES.CHIP	10K 2% 1/10W				
R19	1-208-462-41	RES.CHIP	10K 2% 1/10W				
R20	1-216-689-11	METAL CHIP	39K 0.5% 1/10W				
*****							
		HP BOARD					
		*****					
		(Included in PANEL BOARD, COMPLETE)					
		< CAPACITOR >					
C317	1-161-494-00	CERAMIC	0.022uF 25V				
		< JACK >					
J302	1-568-519-41	JACK, LARGE TYPE (PHONES)					
*****							
*	1-634-841-14	LEAF SW BOARD					
		*****					
		< CONNECTOR >					
* CNP81	1-568-852-11	SOCKET, CONNECTOR 9P					
		< IC >					
IC81	8-749-924-10	IC PHOTO REFLECTOR NJL5165K-B(H1)					
IC82	8-749-924-10	IC PHOTO REFLECTOR NJL5165K-B(H1)					
		< RESISTOR >					
R81	1-249-414-11	CARBON	560 5% 1/4W				
R83	1-247-834-11	CARBON	1.3K 5% 1/4W				
R84	1-249-417-11	CARBON	1K 5% 1/4W				
R85	1-249-408-11	CARBON	180 5% 1/4W				
R86	1-249-408-11	CARBON	180 5% 1/4W				
		< SWITCH >					
S81	1-571-958-11	SWITCH, PUSH (1 KEY) (MECHANISM STOP)					
S82	1-571-281-21	SWITCH, LEAF (70u)					
S83	1-571-281-21	SWITCH, LEAF (METAL)					
S84	1-571-281-21	SWITCH, LEAF (REC)					
S86	1-571-281-21	SWITCH, LEAF (HALF)					
*****							
*	A-2007-776-A	MAIN BOARD, COMPLETE (AEP, AUS)					
		*****					
		(Including TRANSFORMER BOARD)					
*	A-2007-778-A	MAIN BOARD, COMPLETE (MY, SP)					
		*****					
	7-685-871-01	SCREW +BVTT 3X6 (S)					
		< CAPACITOR >					
C101	1-126-963-11	ELECT	4.7uF 20% 50V				
C102	1-106-353-00	MYLAR	0.0027uF 5% 50V				
C103	1-136-173-00	FILM	0.47uF 5% 50V				
C104	1-126-964-11	ELECT	10uF 20% 50V				
C105	1-136-165-00	FILM	0.1uF 5% 50V				
C106	1-136-163-00	FILM	0.068uF 5% 50V				
C107	1-126-964-11	ELECT	10uF 20% 50V				
C110	1-126-959-11	ELECT	0.47uF 20% 50V				
C111	1-126-964-11	ELECT	10uF 20% 50V				
C112	1-126-963-11	ELECT	4.7uF 20% 50V				
C113	1-137-428-11	FILM	180PF 5% 50V				
C114	1-136-935-11	FILM	22PF 5% 630V				
C115	1-137-429-11	FILM	270PF 5% 50V				
C116	1-130-474-00	MYLAR	0.0018uF 5% 50V				
C117	1-130-487-00	MYLAR	0.022uF 5% 50V				
C118	1-107-714-11	ELECT	10uF 20% 16V				
C119	1-102-518-11	CERAMIC	33PF 5% 50V				
C120	1-130-488-00	MYLAR	0.027uF 5% 50V				
C121	1-126-961-11	ELECT	2.2uF 20% 50V				
C122	1-130-483-00	MYLAR	0.01uF 5% 50V				
C123	1-130-487-00	MYLAR	0.022uF 5% 50V				
C124	1-130-491-00	MYLAR	0.047uF 5% 50V				
C125	1-136-803-11	FILM	560PF 5% 630V				
C126	1-130-468-00	MYLAR	560PF 5% 50V				
C127	1-136-433-11	FILM	100PF 5% 630V				
C128	1-130-474-00	MYLAR	0.0018uF 5% 50V				
C130	1-106-351-00	MYLAR	2200PF 5% 200V				
C131	1-126-964-11	ELECT	10uF 20% 50V				
C132	1-136-165-00	FILM	0.1uF 5% 50V				
C133	1-136-163-00	FILM	0.068uF 5% 50V				
C136	1-126-964-11	ELECT	10uF 20% 50V				
C150	1-162-302-11	CERAMIC	0.0022uF 20% 16V				
C201	1-126-963-11	ELECT	4.7uF 20% 50V				
C202	1-106-353-00	MYLAR	0.0027uF 5% 50V				
C203	1-136-173-00	FILM	0.47uF 5% 50V				
C204	1-126-964-11	ELECT	10uF 20% 50V				
C205	1-136-165-00	FILM	0.1uF 5% 50V				
C206	1-136-163-00	FILM	0.068uF 5% 50V				
C207	1-126-964-11	ELECT	10uF 20% 50V				
C210	1-126-959-11	ELECT	0.47uF 20% 50V				
C211	1-126-964-11	ELECT	10uF 20% 50V				
C212	1-126-963-11	ELECT	4.7uF 20% 50V				
C213	1-137-428-11	FILM	180PF 5% 50V				
C214	1-136-935-11	FILM	22PF 5% 630V				
C215	1-137-429-11	FILM	270PF 5% 50V				
C216	1-130-474-00	MYLAR	0.0018uF 5% 50V				
C217	1-130-487-00	MYLAR	0.022uF 5% 50V				
C218	1-107-714-11	ELECT	10uF 20% 16V				
C219	1-102-518-11	CERAMIC	33PF 5% 50V				
C220	1-130-488-00	MYLAR	0.027uF 5% 50V				
C221	1-126-961-11	ELECT	2.2uF 20% 50V				
C222	1-130-483-00	MYLAR	0.01uF 5% 50V				
C223	1-130-487-00	MYLAR	0.022uF 5% 50V				
C224	1-130-491-00	MYLAR	0.047uF 5% 50V				
C225	1-136-803-11	FILM	560PF 5% 630V				

# MAIN

Ref. No.	Part No.	Description			Remark	Ref. No.	Part No.	Description			Remark
C226	1-130-468-00	MYLAR	560PF	5%	50V	C831	1-104-665-11	ELECT	100uF	20%	10V
C227	1-136-433-11	FILM	100PF	5%	630V						
C228	1-130-474-00	MYLAR	0.0018uF	5%	50V			< CONNECTOR >			
C230	1-106-351-00	MYLAR	2200PF	5%	200V						
C231	1-126-964-11	ELECT	10uF	20%	50V	CN101	1-695-087-11	PIN, CONNECTOR (PC BOARD)	7P		
						CN102	1-695-087-11	PIN, CONNECTOR (PC BOARD)	7P		
C232	1-136-165-00	FILM	0.1uF	5%	50V	CN201	1-695-087-11	PIN, CONNECTOR (PC BOARD)	7P		
C233	1-136-163-00	FILM	0.068uF	5%	50V	CN202	1-695-087-11	PIN, CONNECTOR (PC BOARD)	7P		
C236	1-126-964-11	ELECT	10uF	20%	50V	* CN801	1-568-954-11	PIN, CONNECTOR	5P		
C250	1-162-302-11	CERAMIC	0.0022uF	20%	16V						
C301	1-126-964-11	ELECT	10uF	20%	50V	* CN803	1-568-828-11	SOCKET, CONNECTOR	9P		
						* CN804	1-568-826-11	SOCKET, CONNECTOR	7P		
C302	1-126-964-11	ELECT	10uF	20%	50V	CN805	1-778-065-11	SOCKET, CONNECTOR	39P		
C303	1-130-478-00	MYLAR	0.0039uF	5%	50V	CNP301	1-506-468-11	PIN, CONNECTOR	3P		
C304	1-126-959-11	ELECT	0.47uF	20%	50V	* CNP302	1-560-062-00	PIN, CONNECTOR	4P		
C305	1-130-494-11	MYLAR	0.082uF	5%	50V						
C306	1-126-960-11	ELECT	1uF	20%	50V	* CNP303	1-560-060-00	PIN, CONNECTOR	2P		
						* CNP304	1-560-062-00	PIN, CONNECTOR	4P		
C307	1-104-665-11	ELECT	100uF	20%	10V	CNP305	1-691-463-11	PIN, CONNECTOR (PC BOARD)	7P		
C308	1-104-665-11	ELECT	100uF	20%	10V	CNP306	1-764-328-11	PIN, CONNECTOR (PCB)(V TYPE)	5P		
C309	1-162-282-31	CERAMIC	100PF	10%	50V			< DIODE >			
C310	1-161-494-00	CERAMIC	0.022uF		25V						
C311	1-126-961-11	ELECT	2.2uF	20%	50V	D101	8-719-911-19	DIODE	1SS119		
						D102	8-719-911-19	DIODE	1SS119		
C312	1-162-217-31	CERAMIC	56PF	5%	50V	D103	8-719-933-33	DIODE	HZS6A1L		
C313	1-126-961-11	ELECT	2.2uF	20%	50V	D201	8-719-911-19	DIODE	1SS119		
C319	1-126-964-11	ELECT	10uF	20%	50V	D202	8-719-911-19	DIODE	1SS119		
C320	1-126-947-11	ELECT	47uF	20%	35V						
C321	1-126-947-11	ELECT	47uF	20%	35V	D203	8-719-933-33	DIODE	HZS6A1L		
						D301	8-719-911-19	DIODE	1SS119		
C322	1-137-613-11	MYLAR	0.0018uF	5%	100V	D302	8-719-911-19	DIODE	1SS119		
C323	1-137-613-11	MYLAR	0.0018uF	5%	100V	D305	8-719-911-19	DIODE	1SS119		
C324	1-106-359-00	MYLAR	4700PF	5%	200V	D306	8-719-911-19	DIODE	1SS119		
C325	1-126-965-11	ELECT	22uF	20%	50V						
C326	1-136-558-11	FILM	0.0039uF	5%	630V	D307	8-719-911-19	DIODE	1SS119		
						D308	8-719-911-19	DIODE	1SS119		
C327	1-107-584-11	CERAMIC	4PF	0.25PF	500V	D309	8-719-911-19	DIODE	1SS119		
C330	1-126-964-11	ELECT	10uF	20%	50V	D310	8-719-911-19	DIODE	1SS119		
C331	1-126-964-11	ELECT	10uF	20%	50V	D311	8-719-911-19	DIODE	1SS119		
C332	1-126-961-11	ELECT	2.2uF	20%	50V						
C333	1-126-964-11	ELECT	10uF	20%	50V	D312	8-719-911-19	DIODE	1SS119		
						D313	8-719-911-19	DIODE	1SS119		
C334	1-126-964-11	ELECT	10uF	20%	50V	D341	8-719-911-19	DIODE	1SS119		
C701	1-126-768-11	ELECT	2200uF	20%	16V	D342	8-719-911-19	DIODE	1SS119		
C702	1-126-936-11	ELECT	3300uF	20%	16V	D701	8-719-024-99	DIODE	11ES2-NTA2B		
C703	1-126-916-11	ELECT	1000uF	20%	6.3V						
C704	1-126-947-11	ELECT	47uF	20%	35V	D702	8-719-024-99	DIODE	11ES2-NTA2B		
						D703	8-719-024-99	DIODE	11ES2-NTA2B		
C705	1-126-942-61	ELECT	1000uF	20%	25V	D704	8-719-024-99	DIODE	11ES2-NTA2B		
C706	1-126-942-61	ELECT	1000uF	20%	25V	D705	8-719-911-19	DIODE	1SS119		
C707	1-128-548-11	ELECT	4700uF	20%	25V	D706	8-719-933-33	DIODE	HZS6A1L		
C708	1-126-964-11	ELECT	10uF	20%	50V						
C709	1-126-768-11	ELECT	2200uF	20%	16V	D707	8-719-933-33	DIODE	HZS6A1L		
						D708	8-719-933-33	DIODE	HZS6A1L		
C710	1-126-964-11	ELECT	10uF	20%	50V	D709	8-719-025-03	DIODE	RBA-402-SL		
C711	1-126-937-11	ELECT	4700uF	20%	16V	D710	8-719-986-27	DIODE	HZS12B1LTA		
C712	1-126-964-11	ELECT	10uF	20%	50V	D711	8-719-911-19	DIODE	1SS119		
C713	1-126-927-11	ELECT	2200uF	20%	10V						
C714	1-126-968-11	ELECT	100uF	20%	50V	D712	8-719-200-31	DIODE	21DQ05		
						D713	8-719-985-95	DIODE	HZS7A2LTA		
C715	1-164-159-11	CERAMIC	0.1uF		50V	D714	8-719-911-19	DIODE	1SS119		
C716	1-126-947-11	ELECT	47uF	20%	35V	D715	8-719-911-19	DIODE	1SS119		
C805	1-164-159-11	CERAMIC	0.1uF		50V	D716	8-719-986-00	DIODE	HZS7C1LTA		
C806	1-164-159-11	CERAMIC	0.1uF		50V						
C809	1-126-959-11	ELECT	0.47uF	20%	50V	D717	8-719-024-99	DIODE	11ES2-NTA2B		
						D802	8-719-911-19	DIODE	1SS119		
C811	1-164-159-11	CERAMIC	0.1uF		50V	D803	8-719-911-19	DIODE	1SS119		
C813	1-126-959-11	ELECT	0.47uF	20%	50V	D804	8-719-911-19	DIODE	1SS119		
C830	1-164-159-11	CERAMIC	0.1uF		50V						



Ref. No.	Part No.	Description	Remark	Ref. No.	Part No.	Description	Remark
D814	8-719-911-19	DIODE 1SS119		Q316	8-729-900-74	TRANSISTOR DTC143TS	
D815	8-719-911-19	DIODE 1SS119		Q351	8-729-119-76	TRANSISTOR 2SA1175-HFE	
		< IC >		Q352	8-729-900-65	TRANSISTOR DTA144ES	
IC301	8-759-111-44	IC uPC4570C-1		Q353	8-729-900-80	TRANSISTOR DTC114ES	
IC302	8-752-066-35	IC CXA1563S		Q701	8-729-141-83	TRANSISTOR 2SB1094-LK	
IC303	8-752-070-69	IC CXA1598S		Q702	8-729-209-15	TRANSISTOR 2SD2012	
IC304	8-759-106-56	IC uPC1297CA		Q703	8-729-141-83	TRANSISTOR 2SB1094-LK	
IC305	8-759-634-51	IC M5218AP		Q704	8-729-119-78	TRANSISTOR 2SC403SP-51	
IC306	8-759-634-51	IC M5218AP		Q705	8-729-209-15	TRANSISTOR 2SD2012	
IC307	8-752-066-35	IC CXA1563S		Q706	8-729-119-78	TRANSISTOR 2SC403SP-51	
IC308	8-759-634-50	IC M5218AL		Q707	8-729-119-76	TRANSISTOR 2SA1175-HFE	
IC309	8-759-634-50	IC M5218AL		Q708	8-729-140-04	TRANSISTOR 2SB1116A-L	
IC310	8-759-140-53	IC uPD4053BC		Q802	8-729-900-89	TRANSISTOR DTC144ES	
IC311	8-759-634-51	IC M5218AP		Q803	8-729-900-65	TRANSISTOR DTA144ES	
IC701	8-759-634-51	IC M5218AP		Q804	8-729-900-65	TRANSISTOR DTA144ES	
IC801	8-759-422-06	IC M38172M4-171FP		Q806	8-729-900-80	TRANSISTOR DTC114ES	
IC803	8-759-973-95	IC BA6219B		Q807	8-729-900-80	TRANSISTOR DTC114ES	
IC804	8-759-165-82	IC PST600E-T		Q808	8-729-900-80	TRANSISTOR DTC114ES	
		< JACK >		Q809	8-729-900-80	TRANSISTOR DTC114ES	
J301	1-784-430-11	JACK, PIN 4P (LINE IN, OUT)		Q810	8-729-801-84	TRANSISTOR 2SB1013-4	
		< COIL >		Q814	8-729-900-89	TRANSISTOR DTC144ES	
L101	1-410-780-11	INDUCTOR 27mH				< RESISTOR >	
L121	1-410-778-11	INDUCTOR 18mH		R101	1-249-433-11	CARBON 22K 5% 1/4W	
L201	1-410-780-11	INDUCTOR 27mH		R102	1-249-417-11	CARBON 1K 5% 1/4W	
L221	1-410-778-11	INDUCTOR 18mH		R103	1-247-843-11	CARBON 3.3K 5% 1/4W	
		< FILTER >		R104	1-249-428-11	CARBON 8.2K 5% 1/4W	
LPF101	1-234-037-11	FILTER, LOW PASS		R105	1-249-441-11	CARBON 100K 5% 1/4W	
LPF201	1-234-037-11	FILTER, LOW PASS		R107	1-249-421-11	CARBON 2.2K 5% 1/4W	
		< TRANSISTOR >		R108	1-247-860-11	CARBON 16K 5% 1/4W	
Q101	8-729-900-74	TRANSISTOR DTC143TS		R109	1-249-421-11	CARBON 2.2K 5% 1/4W	
Q102	8-729-900-80	TRANSISTOR DTC114ES		R110	1-249-417-11	CARBON 1K 5% 1/4W	
Q103	8-729-922-37	TRANSISTOR 2SD2144S		R112	1-247-843-11	CARBON 3.3K 5% 1/4W	
Q105	8-729-900-80	TRANSISTOR DTC114ES		R113	1-249-437-11	CARBON 47K 5% 1/4W	
Q201	8-729-900-74	TRANSISTOR DTC143TS		R114	1-249-429-11	CARBON 10K 5% 1/4W	
Q202	8-729-900-80	TRANSISTOR DTC114ES		R116	1-249-425-11	CARBON 4.7K 5% 1/4W	
Q203	8-729-922-37	TRANSISTOR 2SD2144S		R117	1-249-441-11	CARBON 100K 5% 1/4W	
Q205	8-729-900-80	TRANSISTOR DTC114ES		R118	1-249-403-11	CARBON 68 5% 1/4W	
Q301	8-729-119-76	TRANSISTOR 2SA1175-HFE		R119	1-247-882-11	CARBON 130K 5% 1/4W	
Q302	8-729-900-89	TRANSISTOR DTC144ES		R120	1-249-426-11	CARBON 5.6K 5% 1/4W	
Q303	8-729-900-80	TRANSISTOR DTC114ES		R121	1-249-429-11	CARBON 10K 5% 1/4W	
Q304	8-729-900-80	TRANSISTOR DTC114ES		R122	1-249-420-11	CARBON 1.8K 5% 1/4W	
Q305	8-729-119-76	TRANSISTOR 2SA1175-HFE		R123	1-247-838-00	CARBON 2K 5% 1/4W	
Q306	8-729-900-89	TRANSISTOR DTC144ES		R124	1-249-441-11	CARBON 100K 5% 1/4W	
Q307	8-729-900-80	TRANSISTOR DTC114ES		R125	1-249-421-11	CARBON 2.2K 5% 1/4W	
Q308	8-729-900-80	TRANSISTOR DTC114ES		R126	1-249-425-11	CARBON 4.7K 5% 1/4W	
Q309	8-729-900-80	TRANSISTOR DTC114ES		R127	1-249-435-11	CARBON 33K 5% 1/4W	
Q310	8-729-194-57	TRANSISTOR 2SC945-P		△R128	1-219-153-11	FUSIBLE 10 5% 1/4W F	
Q311	8-729-194-57	TRANSISTOR 2SC945-P		R129	1-247-883-00	CARBON 150K 5% 1/4W	
Q312	8-729-922-37	TRANSISTOR 2SD2144S		R130	1-249-434-11	CARBON 27K 5% 1/4W	
Q313	8-729-119-78	TRANSISTOR 2SC403SP-51		R131	1-247-874-11	CARBON 62K 5% 1/4W	
Q314	8-729-119-78	TRANSISTOR 2SC403SP-51		R133	1-249-410-11	CARBON 270 5% 1/4W	
Q315	8-729-900-80	TRANSISTOR DTC114ES		R137	1-249-441-11	CARBON 100K 5% 1/4W	
				R138	1-249-441-11	CARBON 100K 5% 1/4W	
				R139	1-247-864-11	CARBON 24K 5% 1/4W	
				R140	1-249-429-11	CARBON 10K 5% 1/4W	
				R141	1-249-419-11	CARBON 1.5K 5% 1/4W	
				R142	1-249-426-11	CARBON 5.6K 5% 1/4W	

The components identified by mark △ or dotted line with mark △ are critical for safety. Replace only with part number specified.

# MAIN

Ref. No.	Part No.	Description	Quantity	Material	Remark	Ref. No.	Part No.	Description	Quantity	Material	Remark
R143	1-247-843-11	CARBON	3.3K	5%	1/4W	R316	1-247-872-11	CARBON	51K	5%	1/4W
R144	1-249-409-11	CARBON	220	5%	1/4W	R317	1-249-435-11	CARBON	33K	5%	1/4W
R145	1-249-426-11	CARBON	5.6K	5%	1/4W	R318	1-247-864-11	CARBON	24K	5%	1/4W
R152	1-247-887-00	CARBON	220K	5%	1/4W	R319	1-249-436-11	CARBON	39K	5%	1/4W
R201	1-249-433-11	CARBON	22K	5%	1/4W	R320	1-249-435-11	CARBON	33K	5%	1/4W
R202	1-249-417-11	CARBON	1K	5%	1/4W	R321	1-247-856-00	CARBON	11K	5%	1/4W
R203	1-247-843-11	CARBON	3.3K	5%	1/4W	R322	1-249-432-11	CARBON	18K	5%	1/4W
R204	1-249-428-11	CARBON	8.2K	5%	1/4W	R323	1-247-864-11	CARBON	24K	5%	1/4W
R205	1-249-441-11	CARBON	100K	5%	1/4W	R324	1-247-874-11	CARBON	62K	5%	1/4W
R207	1-249-421-11	CARBON	2.2K	5%	1/4W	R325	1-247-862-11	CARBON	20K	5%	1/4W
R208	1-247-860-11	CARBON	16K	5%	1/4W	R326	1-249-437-11	CARBON	47K	5%	1/4W
R209	1-249-421-11	CARBON	2.2K	5%	1/4W	R327	1-247-852-11	CARBON	7.5K	5%	1/4W
R210	1-249-417-11	CARBON	1K	5%	1/4W	R328	1-247-860-11	CARBON	16K	5%	1/4W
R212	1-247-843-11	CARBON	3.3K	5%	1/4W	R329	1-247-862-11	CARBON	20K	5%	1/4W
R213	1-249-437-11	CARBON	47K	5%	1/4W	R330	1-247-836-11	CARBON	1.6K	5%	1/4W
R214	1-249-429-11	CARBON	10K	5%	1/4W	R331	1-249-425-11	CARBON	4.7K	5%	1/4W
R216	1-249-425-11	CARBON	4.7K	5%	1/4W	R332	1-249-422-11	CARBON	2.7K	5%	1/4W
R217	1-249-441-11	CARBON	100K	5%	1/4W	R333	1-249-417-11	CARBON	1K	5%	1/4W
R218	1-249-403-11	CARBON	68	5%	1/4W	R334	1-249-417-11	CARBON	1K	5%	1/4W
R219	1-247-882-11	CARBON	130K	5%	1/4W	R335	1-249-413-11	CARBON	470	5%	1/4W
R220	1-249-426-11	CARBON	5.6K	5%	1/4W	R336	1-247-832-11	CARBON	1.1K	5%	1/4W
R221	1-249-429-11	CARBON	10K	5%	1/4W	R337	1-249-429-11	CARBON	10K	5%	1/4W
R222	1-249-420-11	CARBON	1.8K	5%	1/4W	R338	1-249-421-11	CARBON	2.2K	5%	1/4W
R223	1-247-838-00	CARBON	2K	5%	1/4W	R339	1-249-440-11	CARBON	82K	5%	1/4W
R224	1-249-441-11	CARBON	100K	5%	1/4W	R340	1-249-440-11	CARBON	82K	5%	1/4W
R225	1-249-421-11	CARBON	2.2K	5%	1/4W	R341	1-249-390-11	CARBON	5.6	5%	1/4W
R226	1-249-425-11	CARBON	4.7K	5%	1/4W	R342	1-249-390-11	CARBON	5.6	5%	1/4W
R227	1-249-435-11	CARBON	33K	5%	1/4W	R343	1-249-437-11	CARBON	47K	5%	1/4W
△R228	1-219-153-11	FUSIBLE	10	5%	1/4W F	R344	1-249-429-11	CARBON	10K	5%	1/4W
R229	1-247-883-00	CARBON	150K	5%	1/4W	R345	1-249-433-11	CARBON	22K	5%	1/4W
R230	1-249-434-11	CARBON	27K	5%	1/4W	R346	1-249-437-11	CARBON	47K	5%	1/4W
R231	1-247-874-11	CARBON	62K	5%	1/4W	R349	1-249-427-11	CARBON	6.8K	5%	1/4W
R233	1-249-410-11	CARBON	270	5%	1/4W	R350	1-249-441-11	CARBON	100K	5%	1/4W
R237	1-249-441-11	CARBON	100K	5%	1/4W	R351	1-247-843-11	CARBON	3.3K	5%	1/4W
R238	1-249-441-11	CARBON	100K	5%	1/4W	R352	1-249-429-11	CARBON	10K	5%	1/4W
R239	1-247-864-11	CARBON	24K	5%	1/4W	R353	1-249-429-11	CARBON	10K	5%	1/4W
R240	1-249-429-11	CARBON	10K	5%	1/4W	R354	1-249-417-11	CARBON	1K	5%	1/4W
R241	1-249-419-11	CARBON	1.5K	5%	1/4W	R355	1-249-401-11	CARBON	47	5%	1/4W
R242	1-249-426-11	CARBON	5.6K	5%	1/4W	R356	1-249-434-11	CARBON	27K	5%	1/4W
R243	1-247-843-11	CARBON	3.3K	5%	1/4W	R357	1-247-848-11	CARBON	5.1K	5%	1/4W
R244	1-249-409-11	CARBON	220	5%	1/4W	R358	1-247-870-11	CARBON	43K	5%	1/4W
R245	1-249-426-11	CARBON	5.6K	5%	1/4W	R359	1-249-434-11	CARBON	27K	5%	1/4W
R252	1-247-887-00	CARBON	220K	5%	1/4W	R360	1-249-437-11	CARBON	47K	5%	1/4W
R302	1-247-848-11	CARBON	5.1K	5%	1/4W	R361	1-249-429-11	CARBON	10K	5%	1/4W
R303	1-249-421-11	CARBON	2.2K	5%	1/4W	△R363	1-215-452-00	METAL	20K	1%	1/4W F
R304	1-249-421-11	CARBON	2.2K	5%	1/4W	R365	1-249-433-11	CARBON	22K	5%	1/4W
△R305	1-215-452-00	METAL	20K	1%	1/4W F	R366	1-247-862-11	CARBON	20K	5%	1/4W
R306	1-249-436-11	CARBON	39K	5%	1/4W	R367	1-249-429-11	CARBON	10K	5%	1/4W
R307	1-249-433-11	CARBON	22K	5%	1/4W	R368	1-249-429-11	CARBON	10K	5%	1/4W
R308	1-249-437-11	CARBON	47K	5%	1/4W	R701	1-249-417-11	CARBON	1K	5%	1/4W
△R309	1-215-455-00	METAL	27K	1%	1/4W F	R702	1-249-409-11	CARBON	220	5%	1/4W
R310	1-249-441-11	CARBON	100K	5%	1/4W	R703	1-247-812-11	CARBON	160	5%	1/4W
R311	1-249-441-11	CARBON	100K	5%	1/4W	R704	1-249-420-11	CARBON	1.8K	5%	1/4W
R312	1-249-433-11	CARBON	22K	5%	1/4W	△R705	1-219-139-11	FUSIBLE	0.68	10%	1/4W F
R313	1-249-434-11	CARBON	27K	5%	1/4W	R706	1-249-425-11	CARBON	4.7K	5%	1/4W
R314	1-247-872-11	CARBON	51K	5%	1/4W	R707	1-249-427-11	CARBON	6.8K	5%	1/4W
R315	1-247-866-11	CARBON	30K	5%	1/4W	R708	1-249-419-11	CARBON	1.5K	5%	1/4W
						R709	1-249-419-11	CARBON	1.5K	5%	1/4W

The components identified by mark △ or dotted line with mark △ are critical for safety.  
Replace only with part number specified.

Ref. No.	Part No.	Description	Remark	Ref. No.	Part No.	Description	Remark
R710	1-249-427-11	CARBON	6.8K 5% 1/4W			< TEST PIN >	
R711	1-249-425-11	CARBON	4.7K 5% 1/4W				
R712	1-249-417-11	CARBON	1K 5% 1/4W	TP301	1-564-506-11	PLUG, CONNECTOR 3P (TEST TERMINAL)	
△R713	1-219-139-11	FUSIBLE	0.68 10% 1/4W F	TP301	1-764-326-11	PIN, CONNECTOR (PCB)(V TYPE)3P (TEST TERMINAL)	
R714	1-249-427-11	CARBON	6.8K 5% 1/4W	* TP801	1-560-060-00	PIN, CONNECTOR 2P (TESY TERMINAL)	
△R715	1-219-135-11	FUSIBLE	0.15 10% 1/4W F			< VIBRATOR >	
R716	1-249-425-11	CARBON	4.7K 5% 1/4W	X801	1-577-358-21	VIBRATOR, CERAMIC (4MHZ)	
R717	1-249-417-11	CARBON	1K 5% 1/4W	*****			
△R718	1-219-137-11	FUSIBLE	0.33 10% 1/4W F				
R719	1-249-425-11	CARBON	4.7K 5% 1/4W				
R720	1-247-830-11	CARBON	910 5% 1/4W	*	A-2007-775-A	PANEL BOARD, COMPLETE (AEP, AUS)	
R721	1-249-437-11	CARBON	47K 5% 1/4W			*****	
R722	1-249-437-11	CARBON	47K 5% 1/4W			(Including AC POWER BOARD, HP BOARD, and REC VOL BOARD)	
R723	1-247-843-11	CARBON	3.3K 5% 1/4W				
R724	1-249-429-11	CARBON	10K 5% 1/4W	*	A-2007-777-A	PANEL BOARD, COMPLETE (MY, SP)	
R802	1-249-433-11	CARBON	22K 5% 1/4W			*****	
R803	1-249-441-11	CARBON	100K 5% 1/4W			(Including AC POWER BOARD, HP BOARD, REC VOL BOARD, TRANS1 BOARD, and TRANS 2 BOARD)	
R804	1-249-417-11	CARBON	1K 5% 1/4W				
R805	1-249-425-11	CARBON	4.7K 5% 1/4W				
R807	1-249-422-11	CARBON	2.7K 5% 1/4W				
R808	1-249-425-11	CARBON	4.7K 5% 1/4W	*	3-386-245-11	HOLDER (FL)	
R810	1-249-422-11	CARBON	2.7K 5% 1/4W			< CAPACITOR >	
R811	1-249-422-11	CARBON	2.7K 5% 1/4W	C901	1-104-665-11	ELECT 100uF 20% 10V	
R812	1-249-417-11	CARBON	1K 5% 1/4W			< CONNECTOR >	
R813	1-249-419-11	CARBON	1.5K 5% 1/4W	CN901	1-778-065-11	SOCKET, CONNECTOR 39P	
R814	1-249-421-11	CARBON	2.2K 5% 1/4W			< DIODE >	
R815	1-247-828-11	CARBON	750 5% 1/4W	D901	8-719-911-19	DIODE 1SS119	
R816	1-249-413-11	CARBON	470 5% 1/4W	D902	8-719-911-19	DIODE 1SS119	
△R817	1-212-954-11	FUSIBLE	6.8 5% 1/2W F	D903	8-719-911-19	DIODE 1SS119	
R824	1-249-430-11	CARBON	12K 5% 1/4W			< IC >	
R825	1-249-435-11	CARBON	33K 5% 1/4W	IC901	8-749-014-66	IC NJL56H400	
R826	1-249-429-11	CARBON	10K 5% 1/4W			< TRANSISTOR >	
R831	1-249-429-11	CARBON	10K 5% 1/4W	Q901	8-729-900-89	TRANSISTOR DTC144ES	
R832	1-249-429-11	CARBON	10K 5% 1/4W	Q902	8-729-900-89	TRANSISTOR DTC144ES	
R833	1-249-429-11	CARBON	10K 5% 1/4W	Q903	8-729-900-89	TRANSISTOR DTC144ES	
R834	1-249-434-11	CARBON	27K 5% 1/4W			< RESISTOR >	
R835	1-249-434-11	CARBON	27K 5% 1/4W	R901	1-249-441-11	CARBON 100K 5% 1/4W	
R845	1-249-429-11	CARBON	10K 5% 1/4W	R905	1-247-838-00	CARBON 2K 5% 1/4W	
		< CONPOSITION CIRCUIT BLOCK >		R906	1-249-422-11	CARBON 2.7K 5% 1/4W	
RB801	1-233-199-11	COMPOSITION CIRCUIT BLOCK 10K		R907	1-247-848-11	CARBON 5.1K 5% 1/4W	
		< VARIABLE RESISTOR >		R908	1-249-429-11	CARBON 10K 5% 1/4W	
RV101	1-241-765-11	RES, ADJ, CARBON 22K		R909	1-247-866-11	CARBON 30K 5% 1/4W	
RV102	1-238-019-11	RES, ADJ, CARBON 47K		R910	1-247-838-00	CARBON 2K 5% 1/4W	
RV103	1-241-765-11	RES, ADJ, CARBON 22K		R911	1-249-422-11	CARBON 2.7K 5% 1/4W	
RV121	1-241-763-11	RES, ADJ, CARBON 4.7K		R912	1-247-848-11	CARBON 5.1K 5% 1/4W	
RV201	1-241-765-11	RES, ADJ, CARBON 22K		R923	1-247-807-31	CARBON 100 5% 1/4W	
RV202	1-238-019-11	RES, ADJ, CARBON 47K		R924	1-247-807-31	CARBON 100 5% 1/4W	
RV203	1-241-765-11	RES, ADJ, CARBON 22K				< SWITCH >	
RV221	1-241-763-11	RES, ADJ, CARBON 4.7K		S901	1-572-184-11	SWITCH, KEYBOARD (■)	
RV306	1-241-763-11	RES, ADJ, CARBON 4.7K					
		< TRANSFORMER >					
T101	1-433-344-11	TRANSFORMER, BIAS OSCILLATION					
T201	1-433-344-11	TRANSFORMER, BIAS OSCILLATION					
T301	1-423-614-11	TRANSFORMER, BIAS OSCILLATION					

The components identified by mark △ or dotted line with mark △ are critical for safety. Replace only with part number specified.

**PANEL**

**REC VOL**

**TRANSFORMER**

**TRANS 1**

**TRANS 2**

Ref. No.	Part No.	Description	Remark
S902	1-572-184-11	SWITCH, KEYBOARD (AMS ◀▶)	
S903	1-572-184-11	SWITCH, KEYBOARD (AMS ▶▶)	
S904	1-572-184-11	SWITCH, KEYBOARD (●, REC)	
S905	1-572-184-11	SWITCH, KEYBOARD (○, REC MUTING)	
S906	1-572-184-11	SWITCH, KEYBOARD (▷)	
S907	1-572-184-11	SWITCH, KEYBOARD (■, PAUSE)	
S908	1-572-184-11	SWITCH, KEYBOARD (MEMORY)	
S909	1-572-184-11	SWITCH, KEYBOARD (RESET)	
< FLUORESCENT INDICATOR TUBE >			
VFD901	1-517-163-11	INDICATOR TUBE, FLUORESCENT	
*****			
REC VOL BOARD			
*****			
(Included in PANEL BOARD, COMPLETE)			
< RESISTOR >			
R153	1-249-425-11	CARBON	4.7K 5% 1/4W
R253	1-249-425-11	CARBON	4.7K 5% 1/4W
R362	1-249-429-11	CARBON	10K 5% 1/4W
R915	1-249-429-11	CARBON	10K 5% 1/4W
R916	1-247-866-11	CARBON	30K 5% 1/4W
R917	1-247-836-11	CARBON	1.6K 5% 1/4W
R918	1-247-840-00	CARBON	2.4K 5% 1/4W
R919	1-247-843-11	CARBON	3.3K 5% 1/4W
R920	1-249-426-11	CARBON	5.6K 5% 1/4W
R921	1-247-858-11	CARBON	13K 5% 1/4W
R922	1-247-868-11	CARBON	36K 5% 1/4W
< VARIABLE RESISTOR >			
RV301	1-225-220-11	RES, VAR, CARBON 50K/50K (REC LEVEL)	
RV302	1-241-897-11	RES, VAR, CARBON 50K/50K (BALANCE)	
RV303	1-241-896-11	RES, VAR, CARBON 10K (BIAS)	
RV304	1-225-568-11	RES, VAR, CARBON 5K/5K (CAL REC LEVEL)	
< SWITCH >			
S910	1-572-184-11	SWITCH, KEYBOARD (MONITOR)	
S911	1-572-184-11	SWITCH, KEYBOARD (AUTO CAL)	
S913	1-762-647-11	SWITCH, ROTARY (DOLBY NR)	
*****			
TRANSFORMER BOARD (AEP, AUS)			
*****			
(Included in MAIN BOARD, COMPLETE)			
* 3-923-762-11	HOLDER (TR)		
< CAPACITOR >			
C718	1-136-165-00	FILM	0.1uF 5% 50V
C719	1-136-165-00	FILM	0.1uF 5% 50V
< CONNECTOR >			
CNP701	1-564-513-11	PLUG, CONNECTOR 10P	
CNP701	1-764-333-11	PIN, CONNECTOR(PCB)(V TYPE)10P	
* CNP702	1-580-230-31	PIN, CONNECTOR (PC BOARD) 2P	

Ref. No.	Part No.	Description	Remark
< LINE FILTER >			
△ LF701	1-424-485-11	FILTER, LINE	
*****			
TRANS 1 BOARD (MY, SP)			
*****			
(Included in PANEL BOARD, COMPLETE)			
< CONNECTOR >			
* CNP702	1-580-230-31	PIN, CONNECTOR (PC BOARD) 2P	
< LINE FILTER >			
△ LF701	1-424-485-11	FILTER, LINE	
*****			
TRANS 2 BOARD (MY, SP)			
*****			
(Included in PANEL BOARD, COMPLETE)			
< CAPACITOR >			
C718	1-136-165-00	FILM	0.1uF 5% 50V
C719	1-136-165-00	FILM	0.1uF 5% 50V
< CONNECTOR >			
CNP701	1-564-513-11	PLUG, CONNECTOR 10P	
CNP701	1-764-333-11	PIN, CONNECTOR(PCB)(V TYPE)10P	
*****			
MISCELLANEOUS			
*****			
△ 7	1-575-651-21	CORD, POWER (AEP,MY,SP)	
△ 7	1-696-845-11	CORD, POWER (AUS)	
△ 11	1-692-155-11	SELECTOR, POWER VOLTAGE (MY,SP)	
59	1-777-109-11	WIRE (FLAT TYPE) (39 CORE)	
103	1-769-915-11	WIRE (FLAT TYPE) (9 CORE)	
104	1-765-314-11	WIRE (FLAT TYPE) (7 CORE)	
159	1-638-983-11	MOTOR FLEXIBLE BOARD	
HE301	1-543-673-11	HEAD, MAGNETIC (ERASE)	
HRP301	1-543-733-11	HEAD, MAGNETIC (RECORD/PLAYBACK)	
M901	X-3363-501-2	MOTOR ASSY (REEL)	
M902	X-3374-302-1	MOTOR ASSY (CAPSTAN)	
△ T701	1-431-668-11	TRANSFORMER, POWER (AEP)	
△ T701	1-431-737-11	TRANSFORMER, POWER (AUS)	
△ T701	1-431-738-11	TRANSFORMER, POWER (MY,SP)	
*****			
*****			
HARDWARE LIST			
*****			
#1	7-685-646-79	SCREW +BVTP 3X8 TYPE2 N-S	
#2	7-685-885-09	SCREW +BVTT 4X16 (S)	
#3	7-685-863-09	SCREW +BVTT 2.6X8 (S)	
#4	7-685-134-19	SCREW +PTPWH 2.6X8 (TYPE2)	
#5	7-685-862-09	SCREW +BVTT 2.6X6 (S)	
#6	7-621-772-10	SCREW +B 2X4	
#7	7-621-775-00	SCREW +B 2.6X3	
#8	7-627-556-08	SCREW +P 2.6X2.8	
*****			

The components identified by mark △ or dotted line with mark △ are critical for safety. Replace only with part number specified.

<u>Ref. No.</u>	<u>Part No.</u>	<u>Description</u>	<u>Remark</u>
		ACCESSORIES & PACKING MATERIALS	
		*****	
	1-776-263-11	CORD, CONNECTION (AUDIO) 1.5m	
	3-862-301-11	MANUAL, INSTRUCTION (ENGLISH, FRENCH, SPANISH, PORTUGUESE)	
	3-862-301-21	MANUAL, INSTRUCTION (GERMAN, DUTCH, SWEDISH, ITALIAN)(AEP)	
	3-862-301-31	MANUAL, INSTRUCTION (CHINESE)(MY,SP)	

