

TC-KE240/RE340

SERVICE MANUAL

AEP Model
TC-KE240/RE340

UK Model
TC-KE240

E Model
Australian Model
TC-RE340



Photo: TC-RE340 (Black type)

Dolby noise reduction and HX Pro headroom extension manufactured under license from Dolby Laboratories Licensing Corporation.
HX Pro originated by Bang & Olufsen.
“DOLBY”, the double-D symbol $\square\square$, and “HX PRO” are trademarks of Dolby Laboratories Licensing Corporation.

Model Name Using Similar Mechanism		NEW
Tape Transport Mechanism Type	KE240	TCM-230ASV1
	RE340	TCM-230ASR4N

SPECIFICATIONS

System

Recording system

4 track 2 channel stereo

Fast-winding time (approx.)

100 sec. (with Sony C 60 cassette)

Bias

AC bias

Signal-to-noise ratio (at peak level and weighted with Dolby NR off)

Type I tape, Sony Type I (NORMAL): 55 dB

Type II tape, Sony Type II (HIGH): 57 dB

Type IV tape, Sony Type IV (METAL): 58 dB

S/N ratio improvement (approximate values)

With Dolby B NR on: 5 dB at 1 kHz, 10 dB at 5 kHz

With Dolby C NR on: 15 dB at 500 Hz, 20 dB at 1 kHz

Harmonic distortion

0.4% (with Type I tape, Sony Type I (NORMAL):
160 nWb/m 315 Hz, 3rd H.D.)

1.8% (with Type IV tape, Sony Type IV (METAL):
250 nWb/m 315 Hz, 3rd H.D.)

Frequency response (Dolby NR off)

Tape type

Type I tape, Sony Type I (NORMAL)	30	15,000 Hz (± 3 dB, IEC),
	20	16,000 Hz (± 6 dB)

Type II tape, Sony Type II (HIGH)	30	16,000 Hz (± 3 dB, IEC),
	20	17,000 Hz (± 6 dB)

Type IV tape, Sony Type IV (METAL)	30	18,000 Hz (± 3 dB, IEC),
	20	19,000 Hz (± 6 dB),
	30	13,000 Hz (± 3 dB, 4 dB recording)

Inputs

Line inputs (phono jacks)

Sensitivity: 0.16 V

Input impedance: 47 kilohms

– Continued on next page –

STEREO CASSETTE DECK

SONY®

Outputs

Line outputs (phono jacks)

Rated output level: 0.5 V at a load impedance of 47 kilohms

Load impedance: Over 10 kilohms

Headphones (stereo phone jack)

Output level: 0.25 mW at a load impedance of 32 ohms

General

Power requirements

Europe and certain countries in Asia: 220 230 V AC, 50/60 Hz

Australia: 240 V AC, 50/60 Hz

Other countries: 110 120/220 240 V AC, 50/60 Hz

Power consumption

TC RE340: 15 W

TC KE240: 14 W

Dimensions (approx.) (w/h/d)

430 × 120 × 290 mm

Mass (approx.)

3.3 kg

Supplied accessories

Audio connecting cords (2)

Design and specifications are subject to change without notice.

Notes on chip component replacement

- Never reuse a disconnected chip component.
- Notice that the minus side of a tantalum capacitor may be damaged by heat.

SAFETY-RELATED COMPONENT WARNING!!

COMPONENTS IDENTIFIED BY MARK \triangle OR DOTTED LINE WITH MARK \triangle ON THE SCHEMATIC DIAGRAMS AND IN THE PARTS LIST ARE CRITICAL TO SAFE OPERATION. REPLACE THESE COMPONENTS WITH SONY PARTS WHOSE PART NUMBERS APPEAR AS SHOWN IN THIS MANUAL OR IN SUPPLEMENTS PUBLISHED BY SONY.

SECTION 1 SERVICING NOTE

TABLE OF CONTENTS

1.	SERVICING NOTE	3
2.	GENERAL	4
3.	DISASSEMBLY	5
4.	MECHANICAL ADJUSTMENTS	10
5.	SERVICE MODE	11
6.	ELECTRICAL ADJUSTMENTS	12
7.	DIAGRAMS	
7-1.	Note for Printed Wiring Boards and Schematic Diagrams	15
7-2.	Printed Wiring Boards – HEAD RELAY (REC/PB)/ LEAF SW (REC/PB) Boards –	18
7-3.	Printed Wiring Board – MAIN Board –	19
7-4.	Schematic Diagram – MAIN Section (1/2) –	20
7-5.	Schematic Diagram – MAIN Section (2/2) –	21
7-6.	Printed Wiring Boards – TRANS/POWER SW Boards –	22
7-7.	Schematic Diagram – TRANS/POWER SW Boards –	23
7-8.	Printed Wiring Board – DISPLAY Board –	24
7-9.	Schematic Diagram – DISPLAY Board –	25
7-10.	Printed Wiring Boards – KEY/HP Boards –	26
7-11.	Schematic Diagram – KEY Board –	26
7-12.	IC Pin Function Description	28
8.	EXPLODED VIEWS	30
9.	ELECTRICAL PARTS LIST	33

MODEL IDENTIFICATION – BACK PANEL –



Model		Part No.
TC-KE240	AEP model	3-042-502-0□
	UK model	3-042-502-1□
TC-RE340	AEP model	3-042-490-0□
	Australian model	3-042-490-1□
	Singapore model	3-042-490-2□

SECTION 2 GENERAL

• LOCATION OF CONTROLS

– Front Panel –

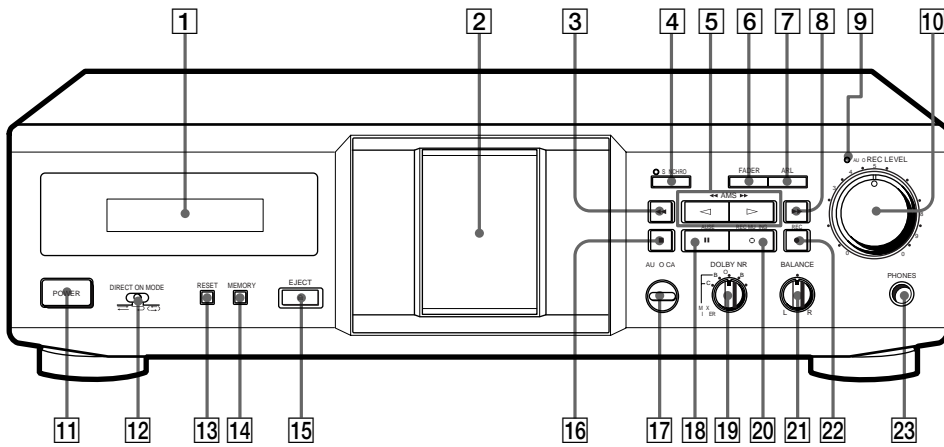

- 1** Fluorescent indicator tube
- 2** Cassette holder
- 3** ◀ button
- 4** SYNCHRO button and indicator
- 5** ▷ button (TC-KE240)
◁, ▷ buttons (TC-KE340)
- 6** FADER button
- 7** ARL button
- 8** ▶▶ button
- 9** AUTO REC LEVEL indicator
- 10** RED LEVEL knob
- 11** POWER button
- 12** DIRECTION MODE button
- 13** RESET button
- 14** MEMORY button
- 15** EJECT button
- 16** ■ button
- 17** AUTO CAL button (TC-RE340)
- 18** ▮ button
- 19** DOLBY NR knob
- 20** ○ button
- 21** BALANCE knob
- 22** ● button
- 23** PHONES jack

SECTION 3 DISASSEMBLY

Note: Follow the disassembly procedure in the numerical order given.

CASE (410726)

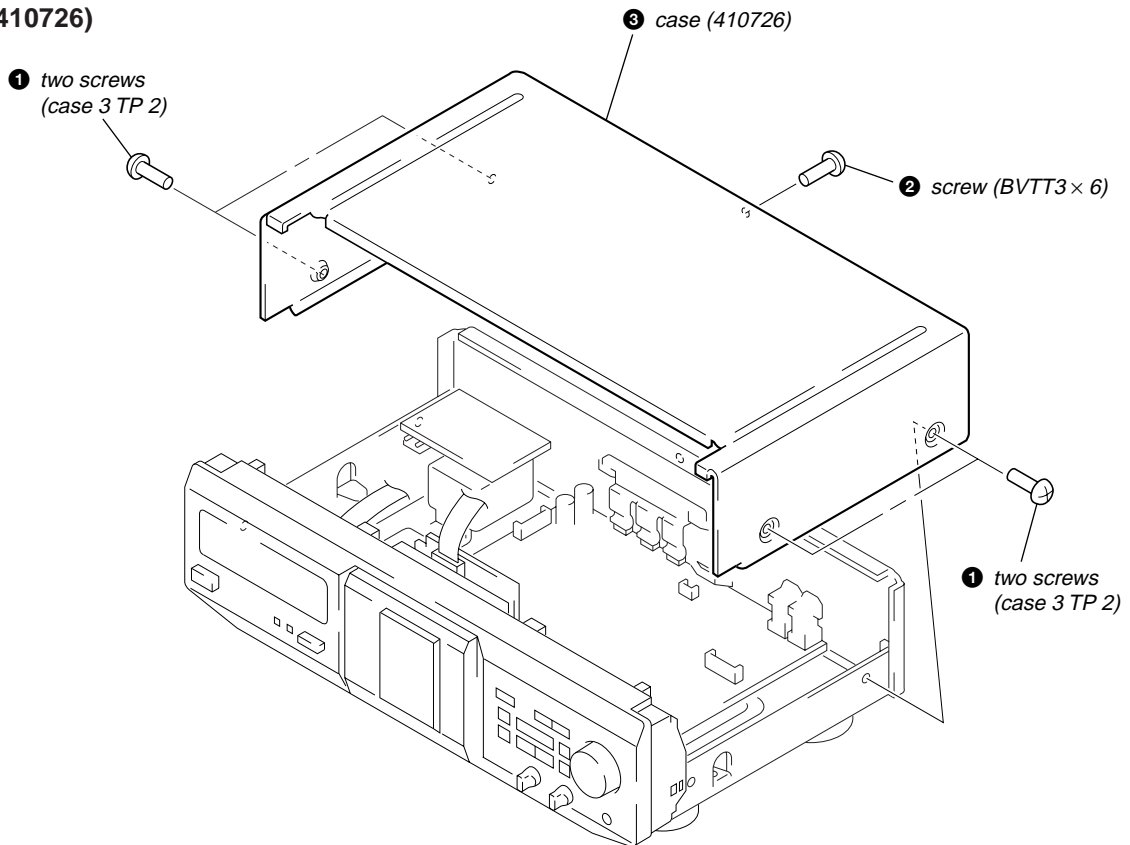

FRONT PANEL SECTION

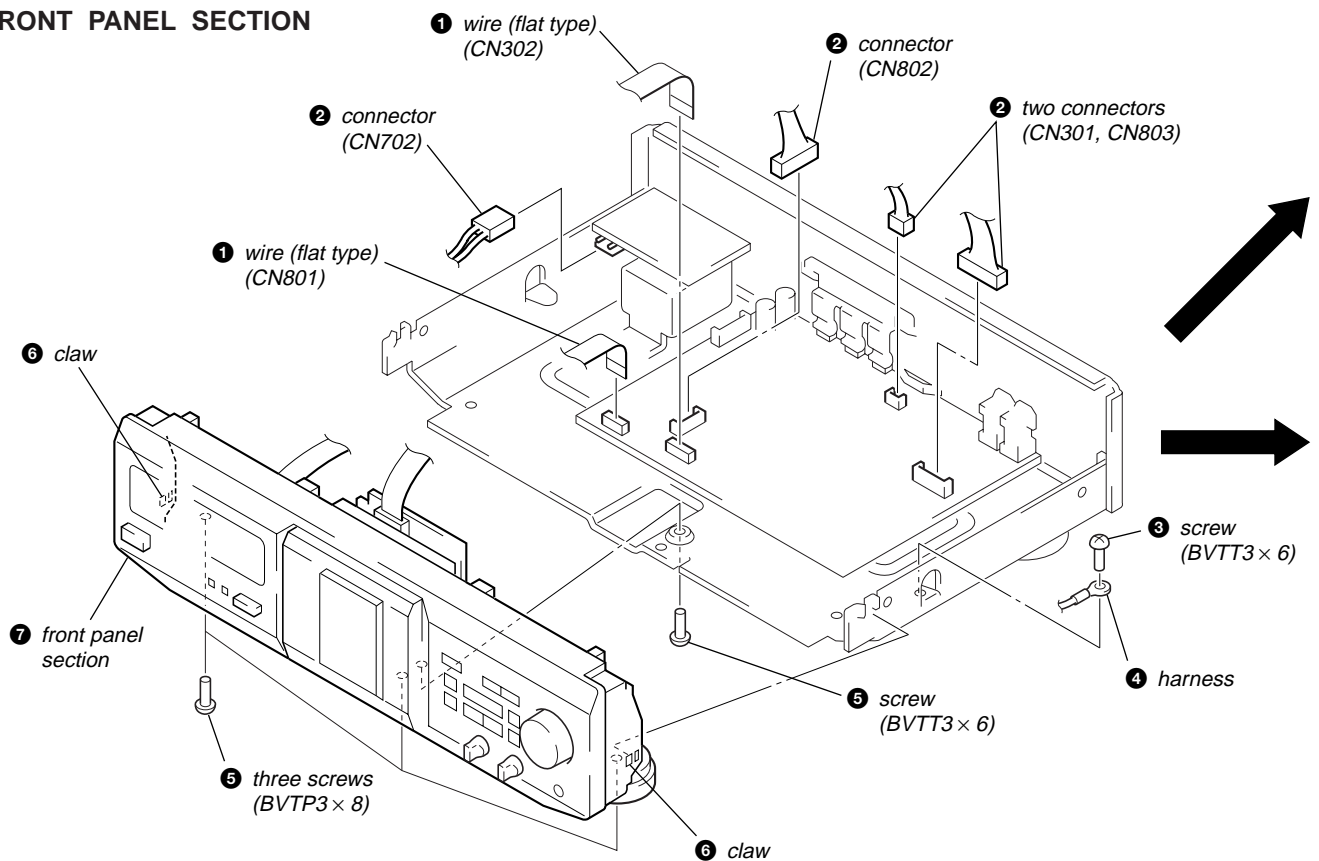

MECHANISM DECK
(TCM-230ASV1: KE240)
(TCM-230ASR4N: RE340)

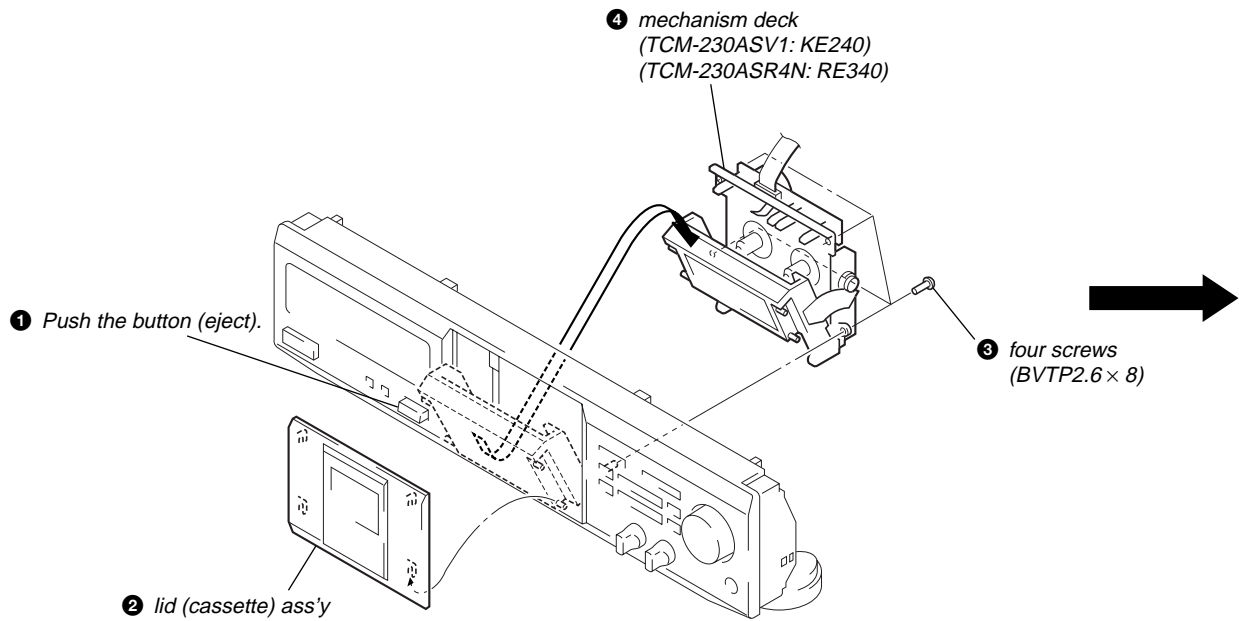

MAIN BOARD

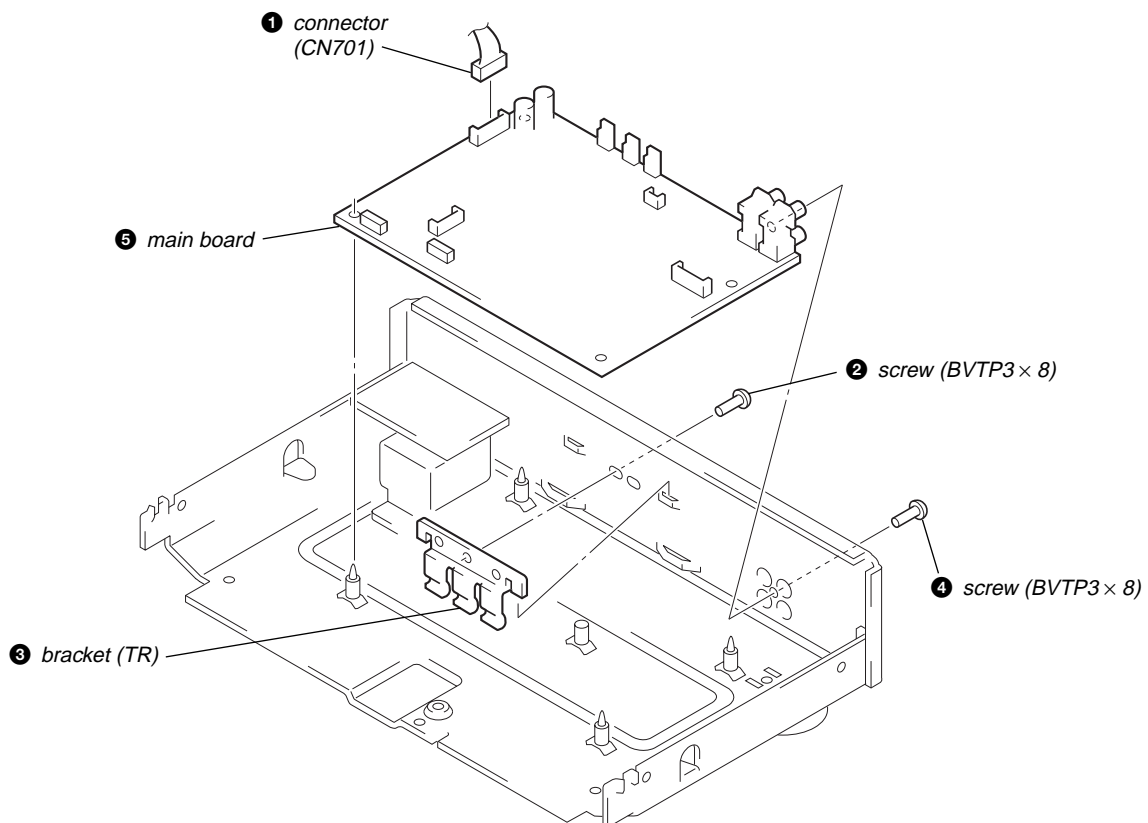

CASSETTE HOLDER (L) ASS'Y

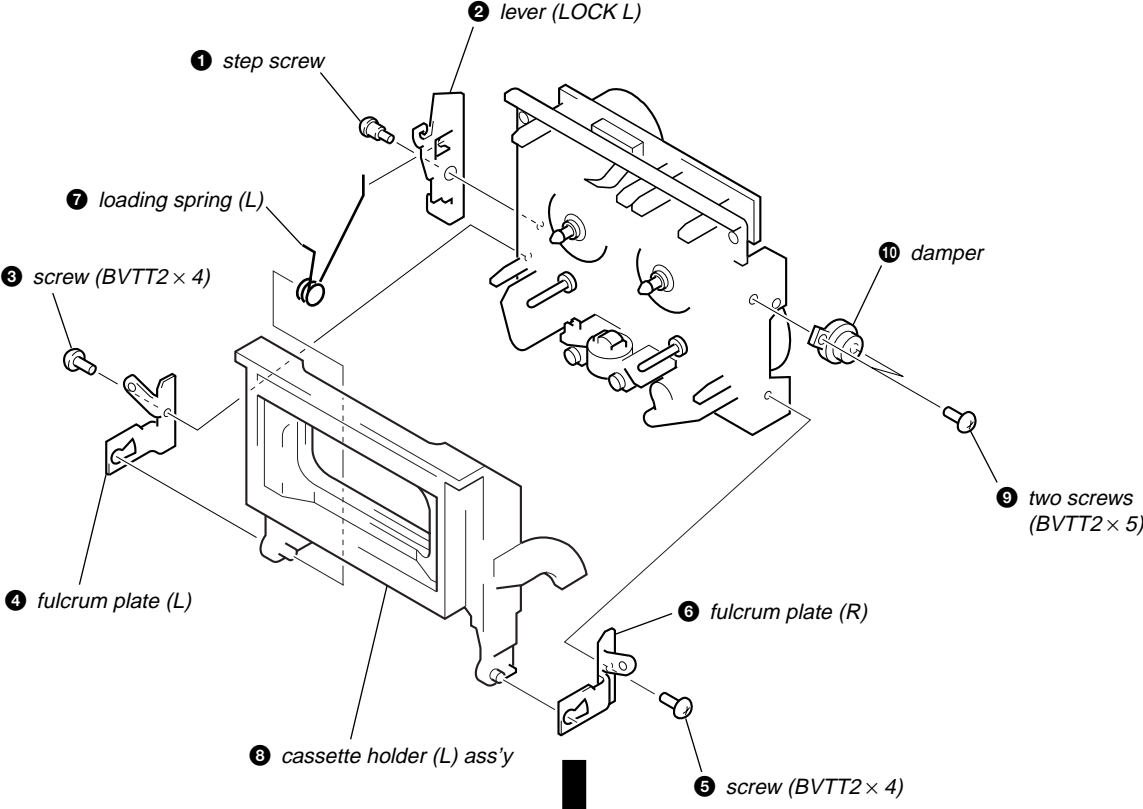

CAPSTAN MOTOR ASS'Y, LEAF SW BOARD

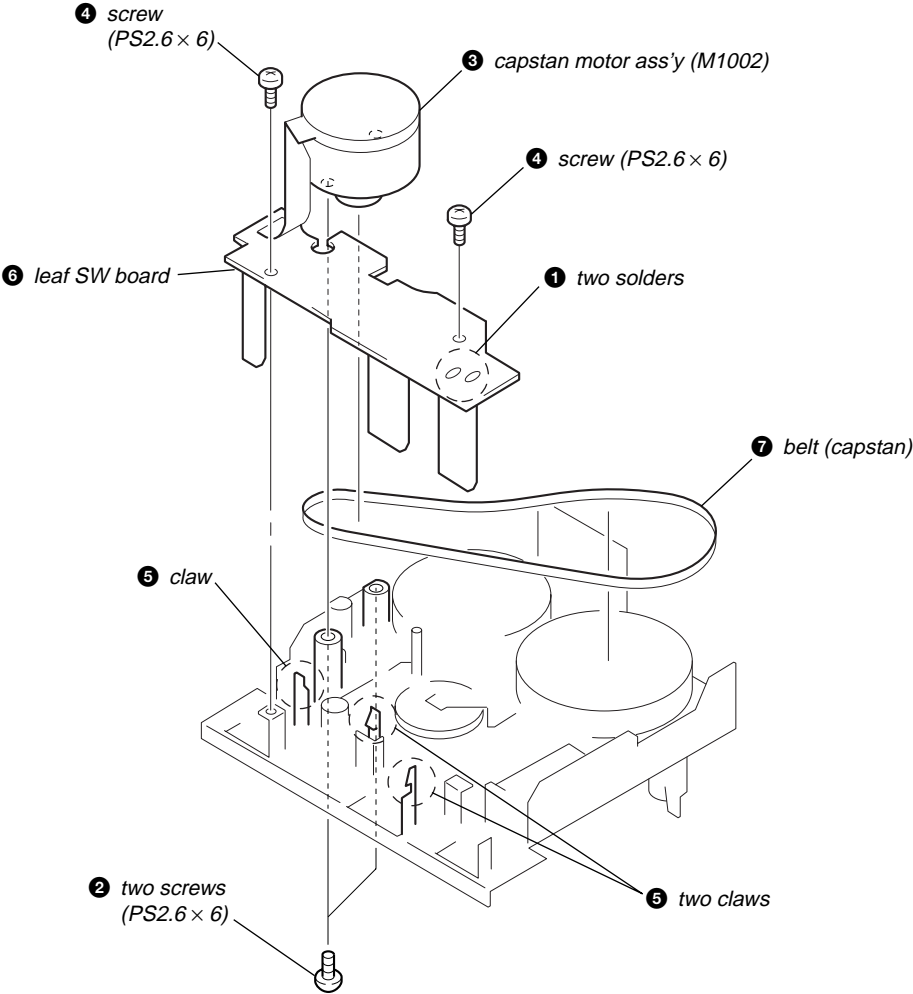

PINCH LEVER ASS'Y

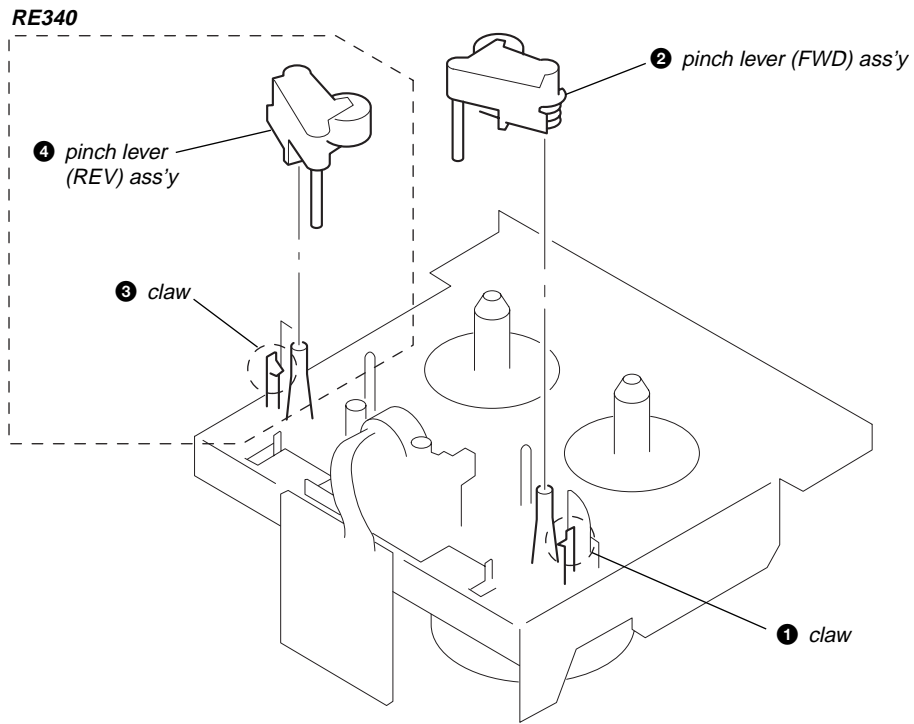

FLYWHEEL ASS'Y

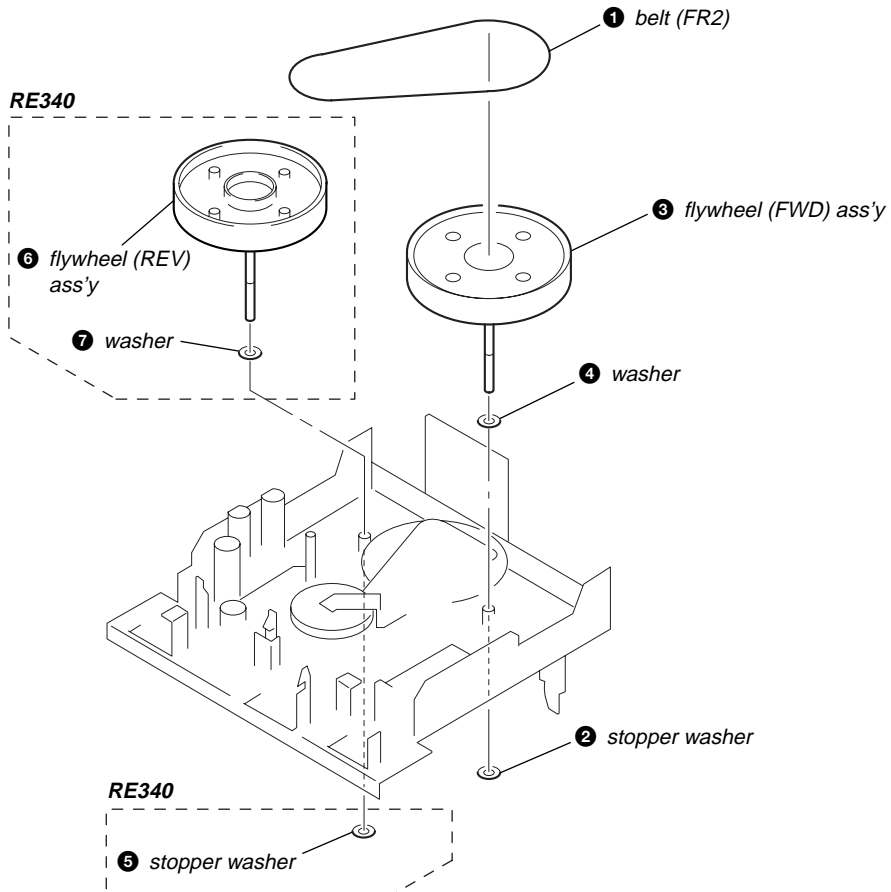

MECHANICAL BLOCK ASS'Y (AMS)

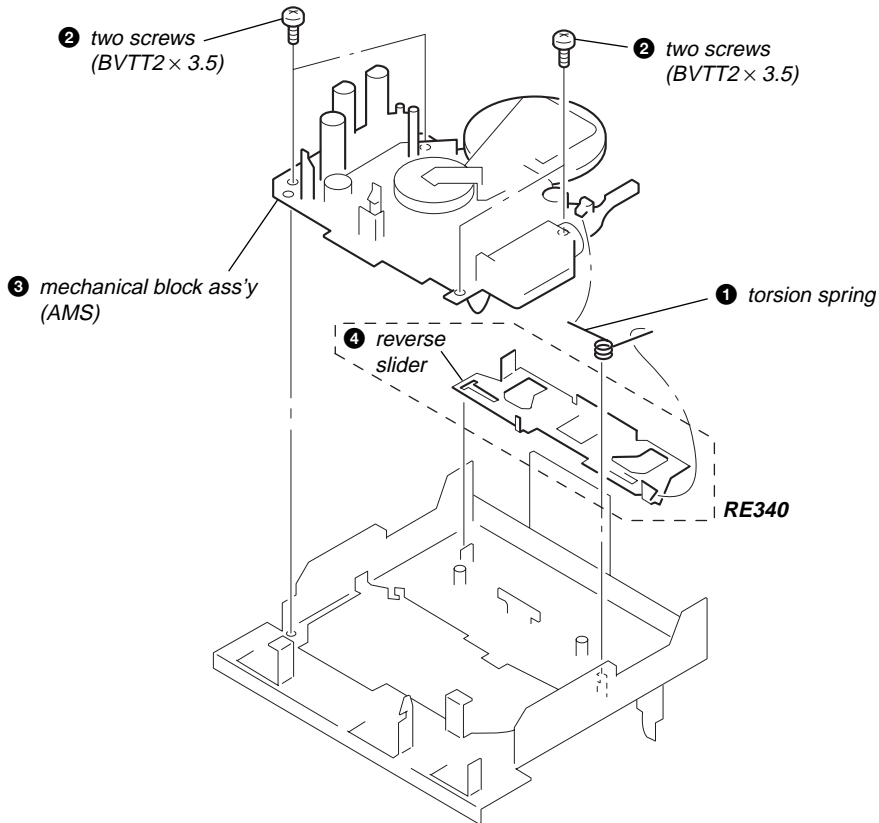

HEAD BASE ASS'Y (KE240), HEAD DECK ASS'Y (RE340), HEAD RELAY BOARD

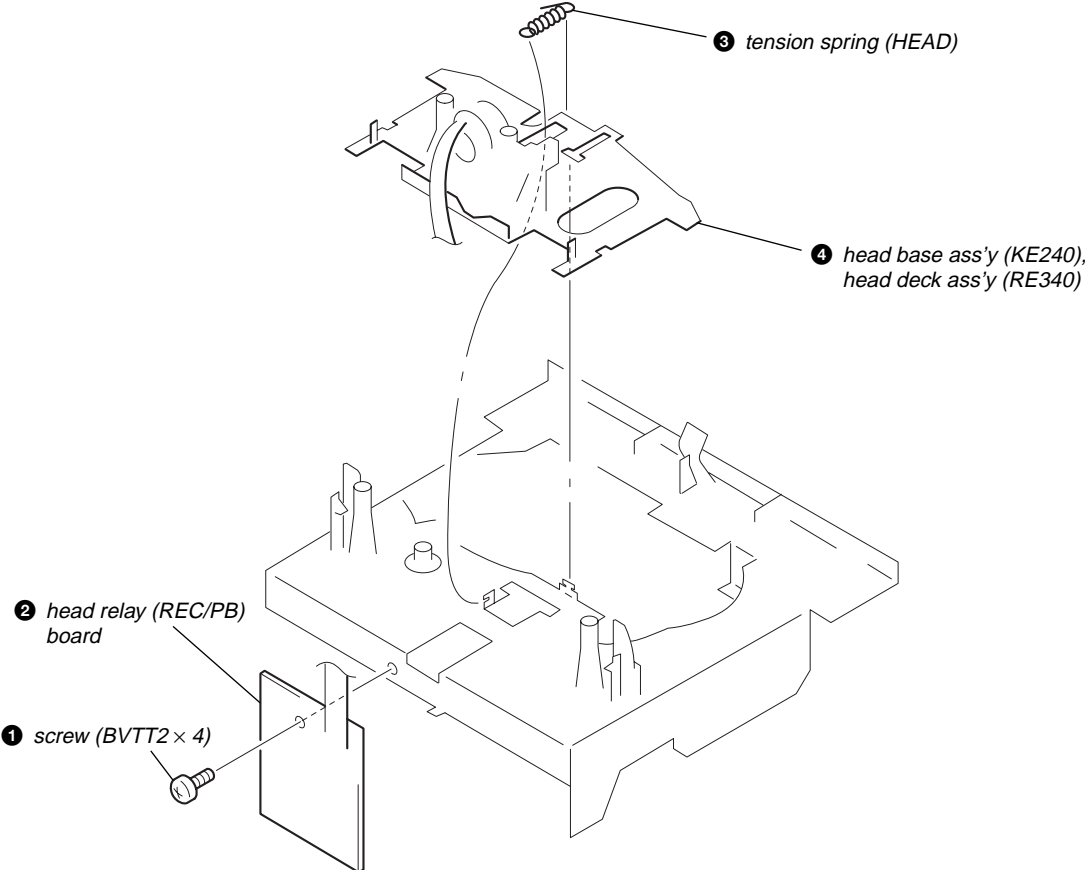

SECTION 4 MECHANICAL ADJUSTMENTS

1. Clean the following parts with a denatured-alcohol-moistened swab:

record/playback/erase head	pinch roller
rubber belt	capstan
idler	
2. Demagnetize the playback head with a head demagnetizer.
3. Do not use a magnetized screwdriver for the adjustments.
4. After the adjustments, apply suitable locking compound to the parts adjusted.
5. The adjustments should be performed with the power supply voltage unless otherwise noted.

• Torque Measurement

Mode	Torque Meter	Meter Reading
Forward	CQ-102C	2.74 – 6.86 mN•m (28 – 69 g•cm) (0.42 – 0.90 oz•inch)
Forward Back Tension	CQ-102C	0.1 – 0.59 mN•m (1.1 – 6.0 g•cm) (0.01 – 0.06 oz•inch)
Reverse	CQ-102RC	2.74 – 6.86 mN•m (30 – 69 g•cm) (0.42 – 0.90 oz•inch)
Reverse Back Tension	CQ-102RC	0.1 – 0.59 mN•m (1.1 – 6.0 g•cm) (0.01 – 0.06 oz•inch)
FF, REW	CQ-201B	6.86 – 15.68 mN•m (70 – 159 g•cm) (0.83 – 2.78 oz•inch)

SECTION 5 SERVICE MODE

Key Check & Display Check Mode

1. While pressing two buttons of **[SYNCHRO]** and **[REC MUTING ○]**, press the **[POWER]** button to turn the power ON.
2. Enter the test mode and display as figure 1.
3. Each time some button is pressed or switch position is selected, the fluorescent indicator tube displays as following table.

Button or Switch		Display
RESET		refer to figure 2
MEMORY		refer to figure 3
SYNCHRO		all segments (refer to figure 4)
FADER		□ (refer to figure 5)
ARL		1
◀◀		2
◁ *1		3
▽		4
▶▶		5
■		6
PAUSE		7
REC MUTING ○		8
REC ●		9
AUTO CAL *1		R
Dolby NR switch	MPX FILTER C	DOLBY NR [C]
	MPX FILTER B	DOLBY NR [B]
	OFF	no indication
	C	[C]
	B	[B]

*1) TC-RE340 only

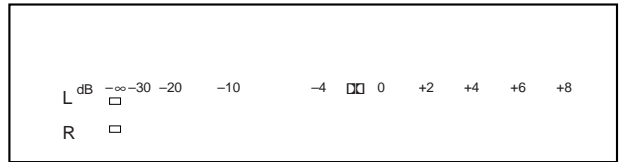

figure 1

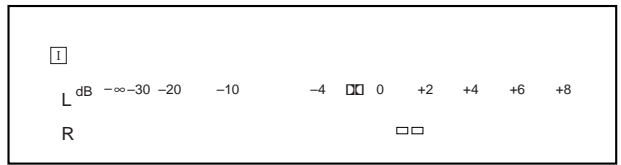

figure 2

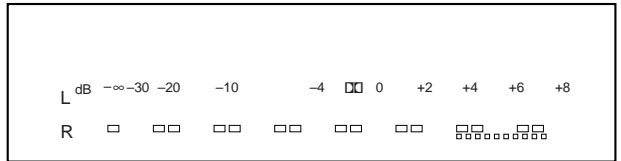

figure 3

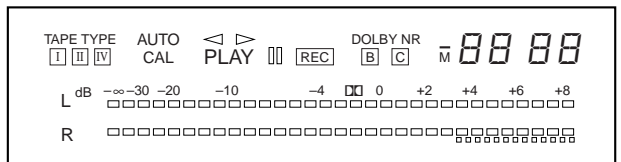

figure 4



figure 5

SECTION 6 ELECTRICAL ADJUSTMENTS

Note: The adjustments should be performed in the order given in the service manual. As a rule, adjustments about playback should be performed before those about recording.

The adjustments should be performed for both L-CH and R-CH.

- Switches and controls should be set as follows unless otherwise specified.

DOLBY NR, MPX FILTER switch: OFF

DIRECTION MODE switch: \longleftrightarrow

- Standard Record:

Deliver the standard input signal level to the input jack and set the [REC LEVEL] volume to obtain the standard output signal level as follows.

– Record Mode –

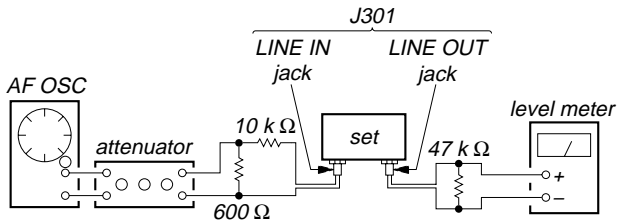

0 dB=0.775 V

Standard Input Level

input terminal	LINE IN
source impedance	10 kΩ
input signal level	0.5 V (-3.8 dB)

Standard Output Level

output terminal	LINE OUT
load impedance	47 kΩ
output signal level	0.5 V (-3.8 dB)

Test Tape

Type	Signal	Used for
P-4-A100	10 kHz, -10 dB	Azimuth Adjustment
P-4-L300	315 Hz, 0 dB	Playback Level Adjustment
WS-48B	3 kHz, 0 dB	Tape Speed Adjustment

Test Mode

- While pressing two buttons of [ARL] and [REC MUTING ○], press the [POWER] button to turn the power on.
- All segments of the fluorescent indicator tube are light up for about one second, and the test mode is set. The test mode has a special function as bellow.
 - Counter RESET & MEMORY Function
 - Press the [RESET] button to reset the counter.
 - Press the [REC ●] button then the [▶] button to starts recording.
 - After record, press the [■] button to stop recording.
 - Press the [◀] button to rewind the tape.
 - Rewinding tape is automatically stopped at the point where recording was started.
- To release the test mode, press the [POWER] button to turn the power off.

Record/Playback Head Azimuth Adjustment

Procedure:

- Mode: FWD playback

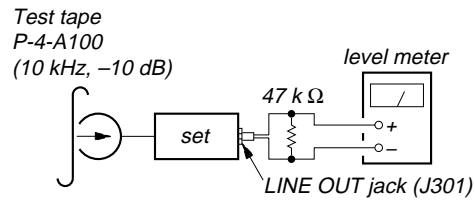

- Turn the adjustment screw for the maximum output levels. If these levels do not match, turn the adjustment screw until both of output levels match together within 1 dB.

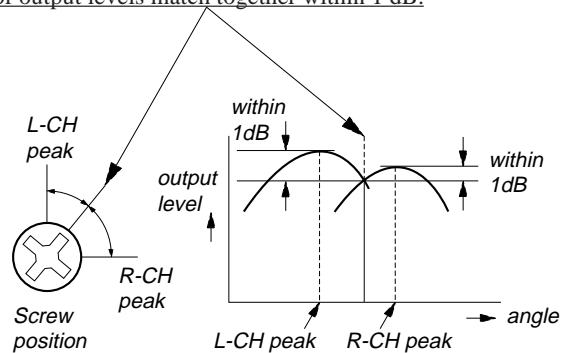

- Phase Check
Mode: playback

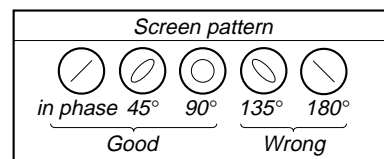
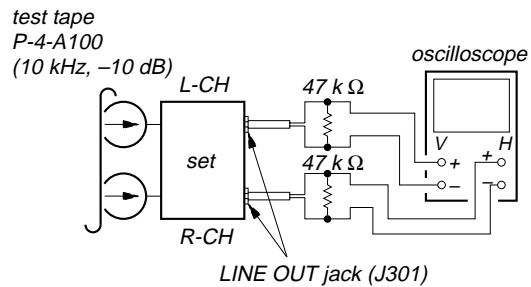

- Change the REV playback mode and repeat the steps 1 to 3. (TC-RE340 only)
- After the adjustment, lock the screw with locking compound.

Adjustment Location: record/playback head (See page 13)

Adjustment Location: record/playback head

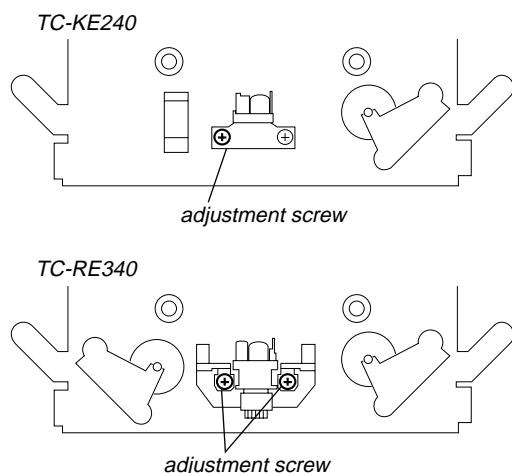

Tape Speed Adjustment

Procedure:

Mode: playback

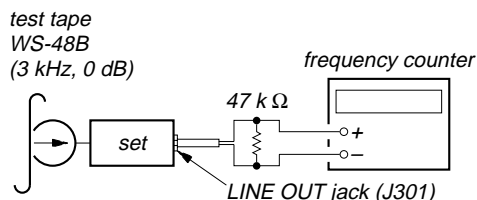

1. Set to the test mode (See page 12).
2. Press the button to playback.
3. Adjust RV301 so that the frequency counter reading becomes 3,000±90 Hz.
4. Frequency difference between the beginning and the end of the tape should be within 3%.

Adjustment Location: MAIN board (See page 14)

Sample value of Wow and Flutter: 0.3% or less W.RMS (JIS) (WS-48B)

Playback Level Adjustment

Procedure:

Mode: playback

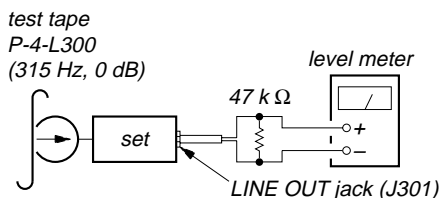

Adjust RV121 (L-CH) and RV221 (R-CH) so that the reading on level meter meets the adjustment limits below.

Adjustment Limits:

LINE OUT level: -7.7 ± 0.5 dB (0.301 to 0.338 V)

Level difference between channels: within 0.5 dB

Check that the LINE OUT level does not change even if playback and stop operation is repeated several times.

Adjustment Location: MAIN board (See page 14)

Bias Consumption Current Adjustment (TC-RE340 only)

Procedure:

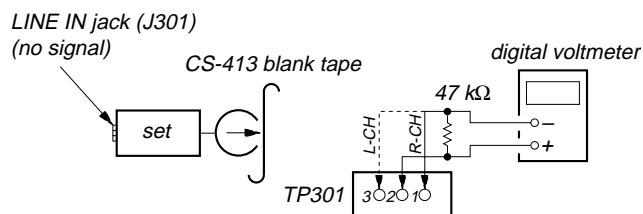

1. Set RV141 (L-CH) and RV241 (R-CH) to mechanical center and turn the set recording mode.
2. Connect digital voltmeter as shown by the following table.
3. Press the button to playback.
4. Adjust the following transformers for the minimum readings on the digital voltmeter.

	Measurement Point	Adjustment Part	Value
L-CH	TP301 pin ② and ③	T101	minimum
R-CH	TP301 pin ① and ②	T201	

Specified value: Maximum 220 mV

Adjustment Location: MAIN board (See page 14)

Record Bias Adjustment

Setting:

[REC LEVEL] volume: standard record position (See page 12)

Procedure:

Mode: record and playback

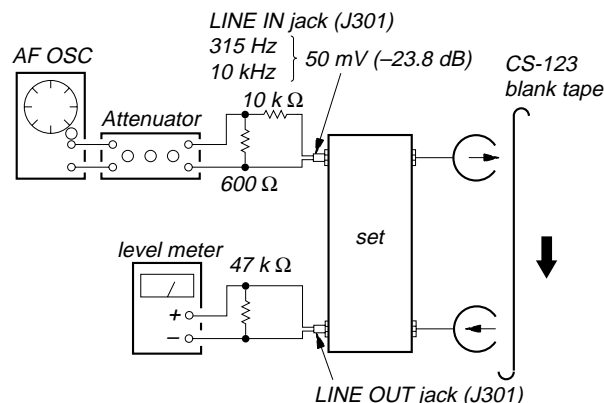

1. Set to the test mode (See page 12).
2. Press the **[REC ●]** button then the button to start recording.
3. Press the **[■]** button to stop recording and press the button to playback.
4. Adjust TC-KE240: RV142 (L-CH) and RV242 (R-CH), TC-RE340: RV141 (L-CH) and RV241 (R-CH) so that 10 kHz playback output is 0 ± 0.3 dB relative to the 315 Hz output.

Adjustment Location: MAIN board (See page 14)

Record Level Adjustment

Setting:

REC LEVEL volume: standard record position (See page 12)

Procedure:

Mode: record and playback

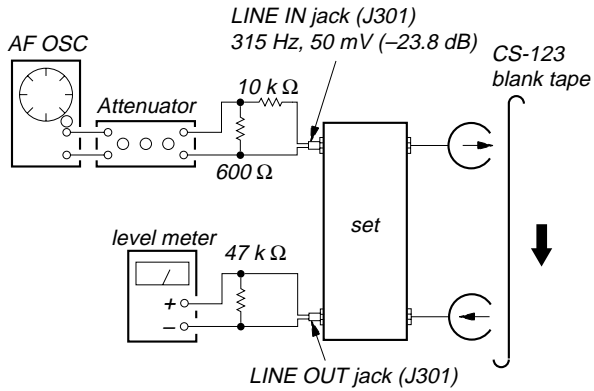

1. Set to the test mode (See page 12).
2. Press the **REC** button then the **▶** button to start recording.
3. Press the **■** button to stop recording and press the **▶** button to playback.
4. Adjust RV101 (L-CH) and RV201 (R-CH) so that the reading on level meter meets the adjustment limits below.

Adjustment Limits: -23.8 ± 0.5 dB (47.2 to 53 mV)

Adjustment Location:

– MAIN BOARD (Component Side) –

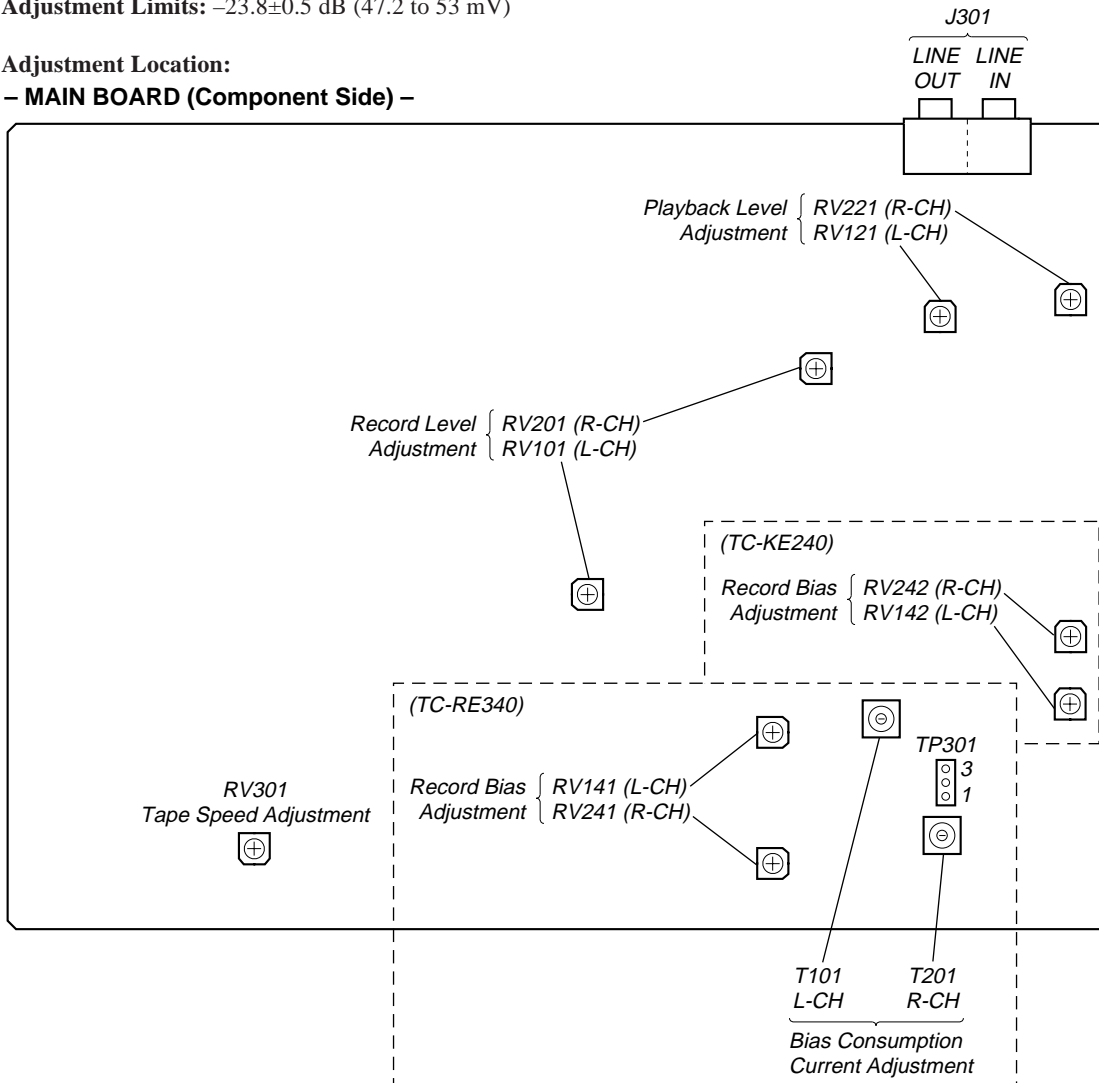



SECTION 7 DIAGRAMS

7-1. NOTE FOR PRINTED WIRING BOARDS AND SCHEMATIC DIAGRAMS



Note on Printed Wiring Boards:

- : parts extracted from the component side.
- : parts extracted from the conductor side.
- ▒ : Pattern from the side which enables seeing.

Note on Schematic Diagram:

- All capacitors are in μF unless otherwise noted. pF : $\mu\mu\text{F}$ 50 WV or less are not indicated except for electrolytics and tantalums.
- All resistors are in Ω and $1/4\text{W}$ or less unless otherwise specified.
- % : indicates tolerance.
- Δ : internal component.
-  : fusible resistor.
-  : panel designation.

Note: The components identified by mark Δ or dotted line with mark Δ are critical for safety.
Replace only with part number specified.

-  : B+ Line.
-  : B- Line.
-  : adjustment for repair.
- Voltages and waveforms are dc with respect to ground under no-signal conditions.
- no mark : STOP
- () : PB
- $\langle \rangle$: REC
- * : Impossible to measure
- Voltages are taken with a VOM (Input impedance 10 M Ω). Voltage variations may be noted due to normal production tolerances.
- Waveforms are taken with a oscilloscope. Voltage variations may be noted due to normal production tolerances.
- Circled numbers refer to waveforms.
- Signal path.
- Σ : PB
- $\Sigma\Sigma$: REC
- Abbreviation
- SP : Singapore model
- AUS : Australian

- **Circuit Boards Location**

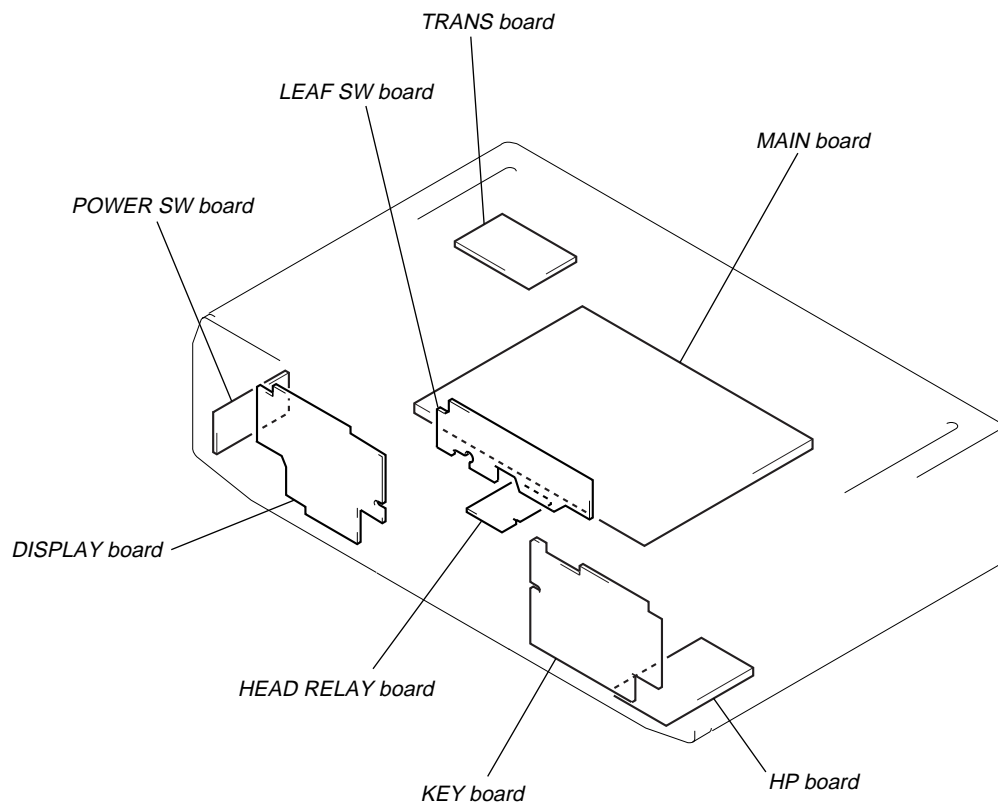

• Waveforms
– MAIN BOARD –

1 IC801 ③ (EXTAL)

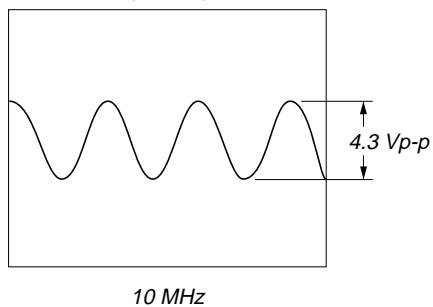

6 Q333 (Base) (REC mode)

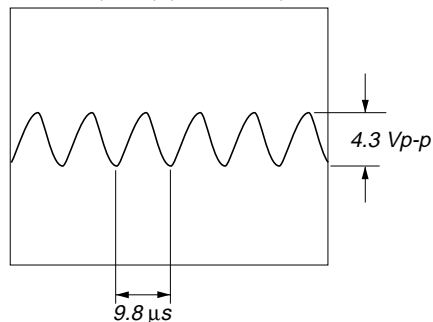

2 IC801 ⑤ (SHUT) (REC or PB mode)

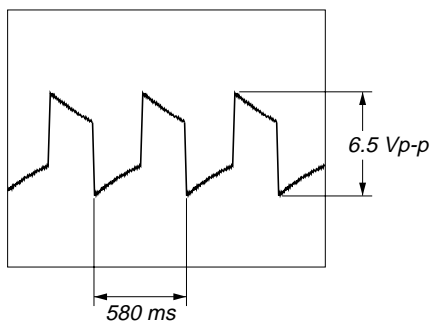

7 Q333 (Collector) (REC mode)

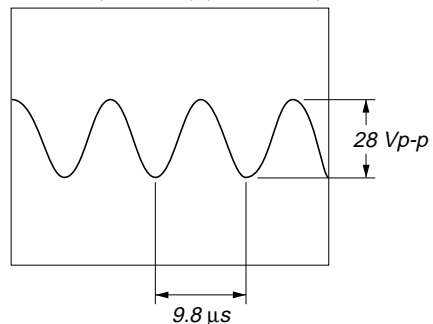

3 IC331 ⑦, ⑧, ⑪, ⑫, (REC mode)
(TC-RE340)

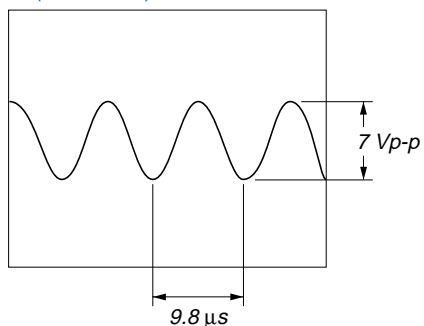

8 IC801 ④ (XIN)

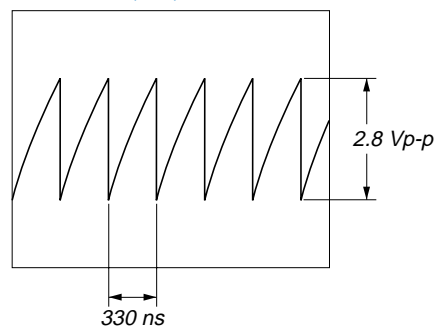

4 Q332 (Base) (REC mode)

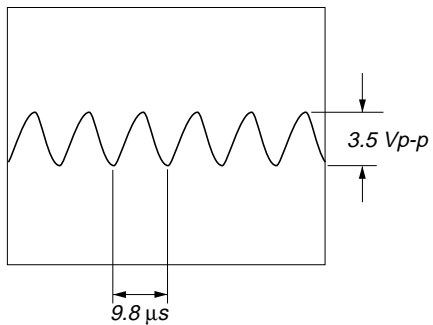

5 Q332 (Collector) (REC mode)

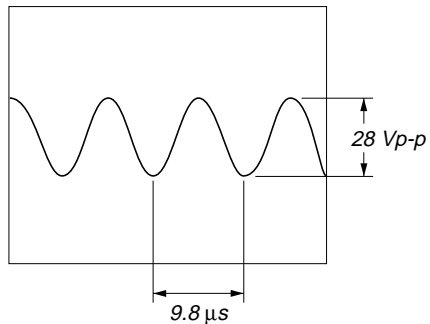

7-2. PRINTED WIRING BOARDS – HEAD RELAY (REC/PB)/LEAF SW (REC/PB) Boards –
 • See page 16 for Circuit Boards Location.

【HEAD RELAY (REC/PB) BOARD】

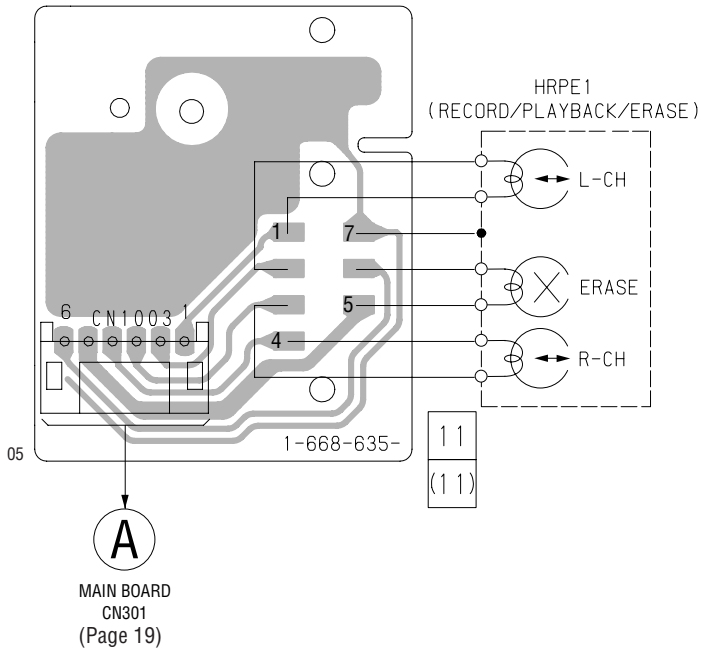

【LEAF SW (REC/PB) BOARD】

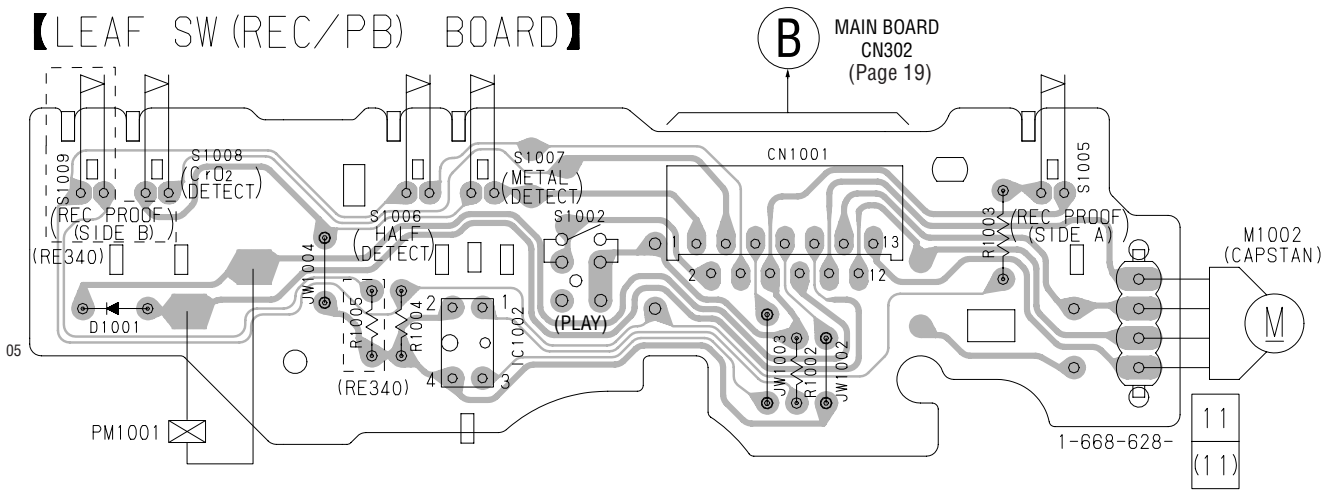

7-3. PRINTED WIRING BOARD – MAIN Board – • See page 16 for Circuit Boards Location.

• Semiconductor Location

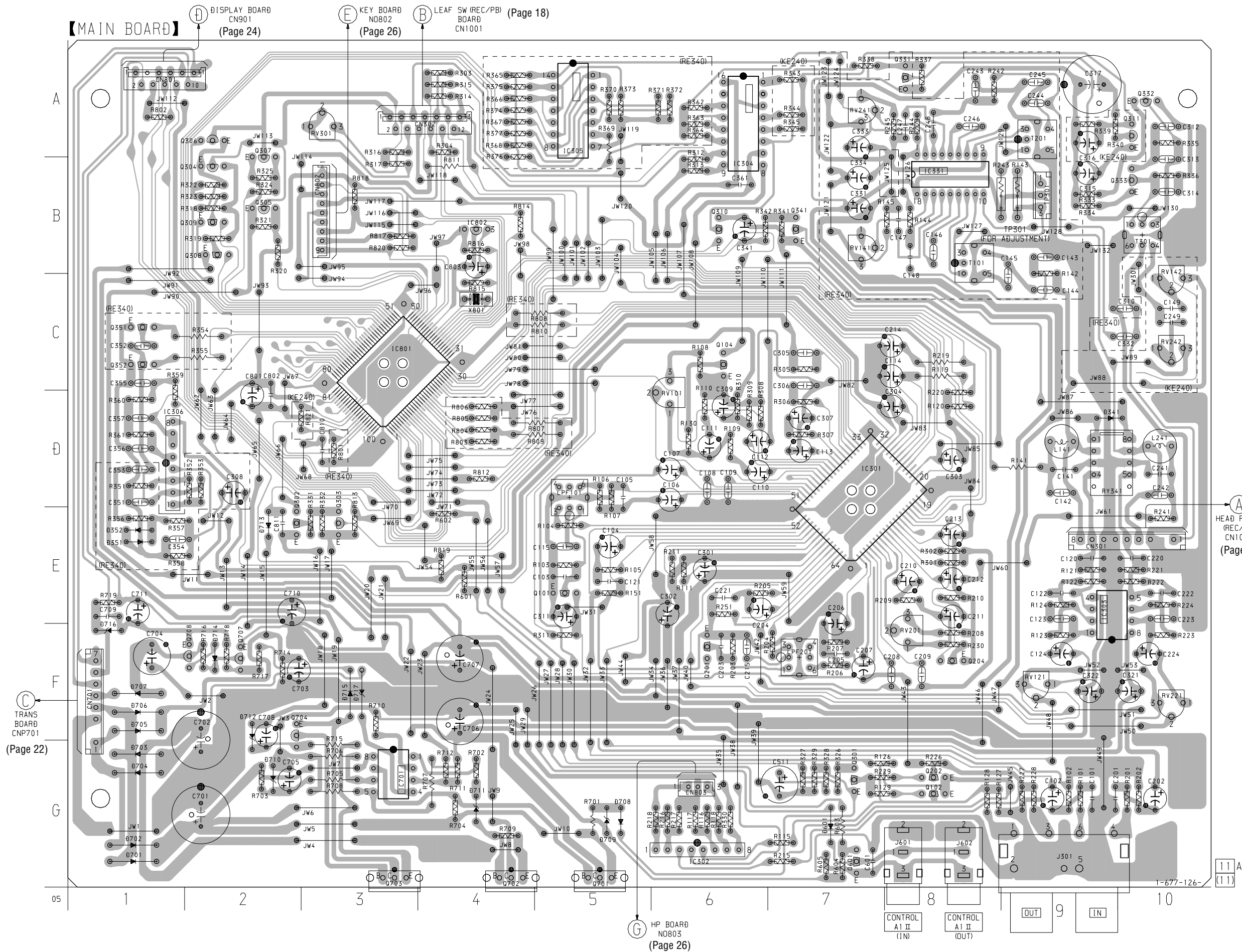

Ref. No.	Location
D341	D-9
D351	E-1
D352	E-1
D601	G-7
D701	G-1
D702	G-1
D703	G-1
D704	G-1
D705	F-1
D706	F-1
D707	F-1
D708	G-5
D709	G-5
D710	G-2
D711	G-4
D712	F-2
D713	E-2
D714	F-2
D715	F-3
D716	F-1
D717	F-3
IC301	D-7
IC302	G-6
IC303	E-9
IC304	A-6
IC305	A-5
IC306	D-1
IC331	B-8
IC701	G-3
IC801	C-3
IC802	B-4
Q101	E-5
Q102	G-8
Q104	C-6
Q201	E-6
Q202	G-8
Q204	F-8
Q301	G-7
Q302	E-2
Q303	E-3
Q304	B-2
Q305	B-2
Q306	A-2
Q307	B-2
Q308	B-2
Q309	B-2
Q310	B-6
Q311	A-10
Q331	A-8
Q332	A-10
Q333	B-10
Q341	B-7
Q351	C-1
Q352	C-1
Q601	G-7
Q701	G-5
Q702	G-4
Q703	G-3
Q704	F-2
Q707	F-2
Q708	F-2

7-4. SCHEMATIC DIAGRAM – MAIN Section (1/2) – • See page 17 for Waveforms.

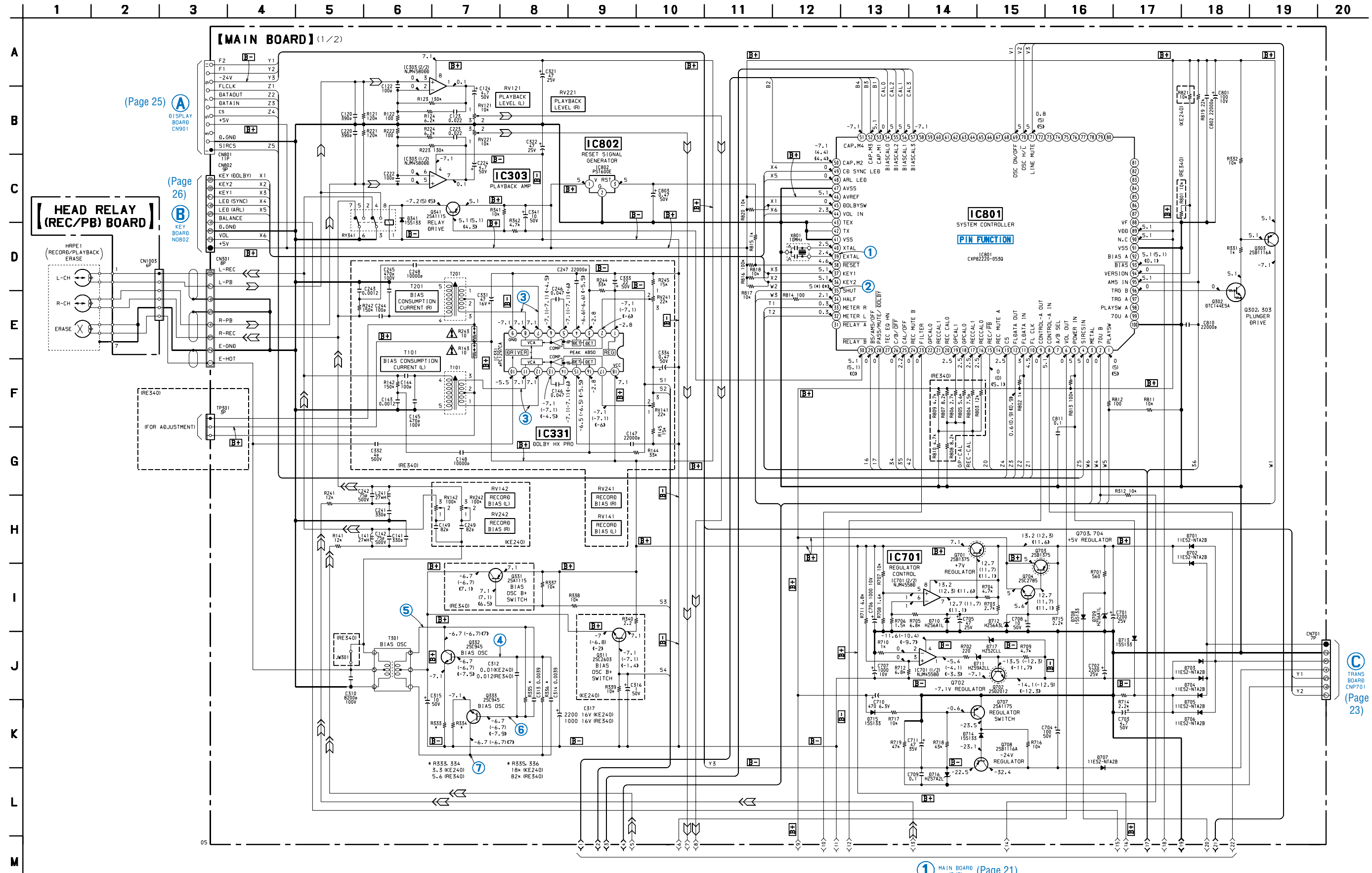

The components identified by mark Δ or dotted line with mark Δ are critical for safety. Replace only with part number specified.

7-5. SCHEMATIC DIAGRAM – MAIN Section (2/2) – • See page 27 for IC Block Diagram.

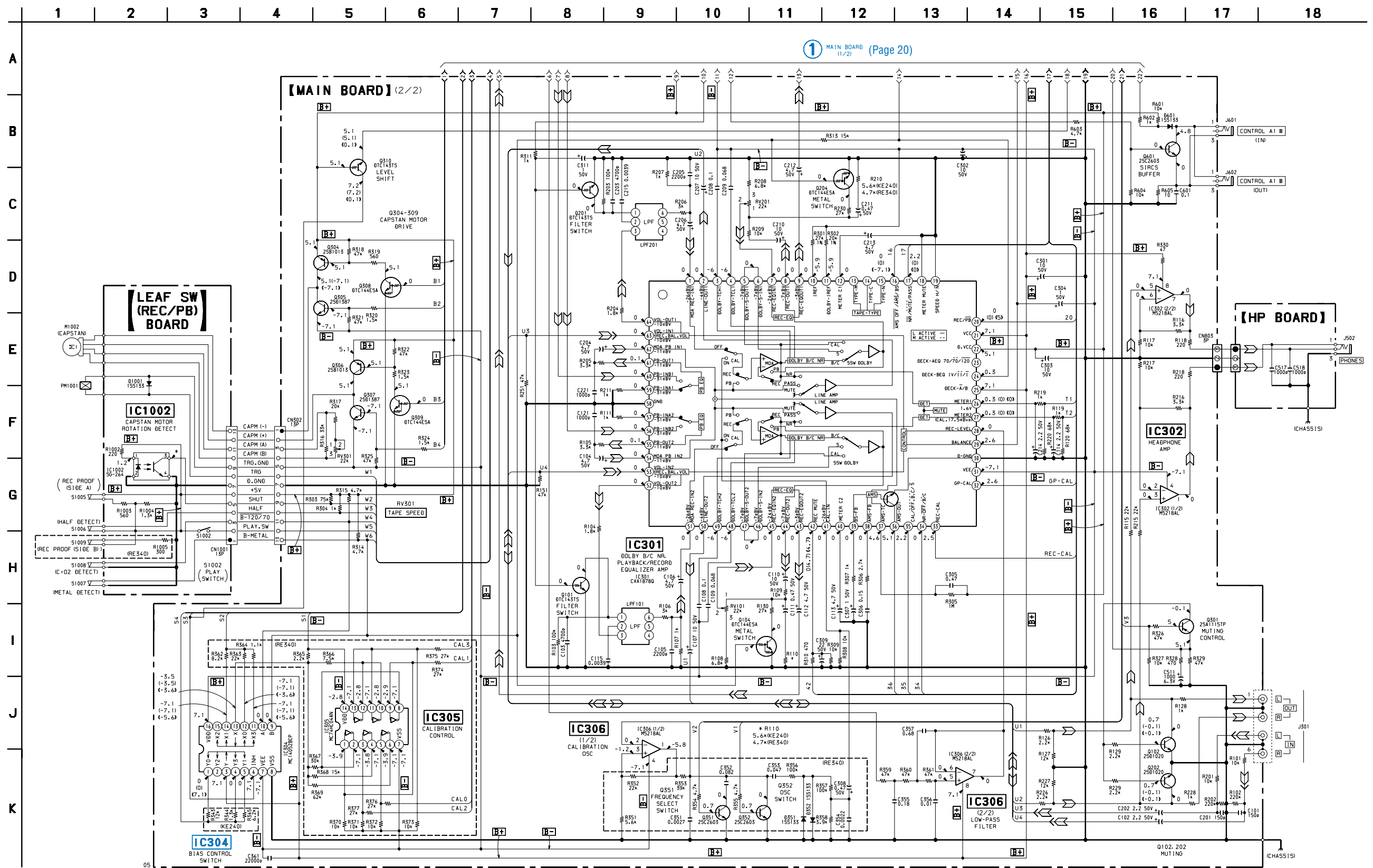

7-6. PRINTED WIRING BOARDS – TRANS/POWER SW Boards – • See page 16 for Circuit Boards Location.

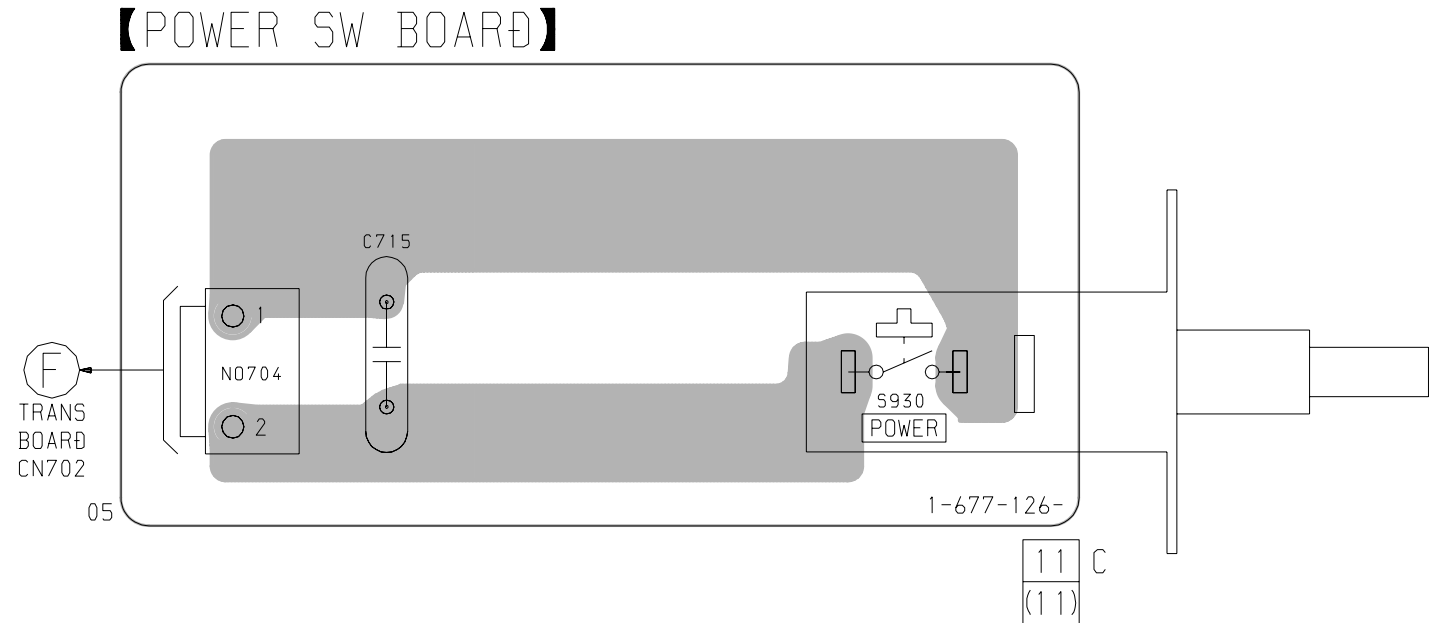
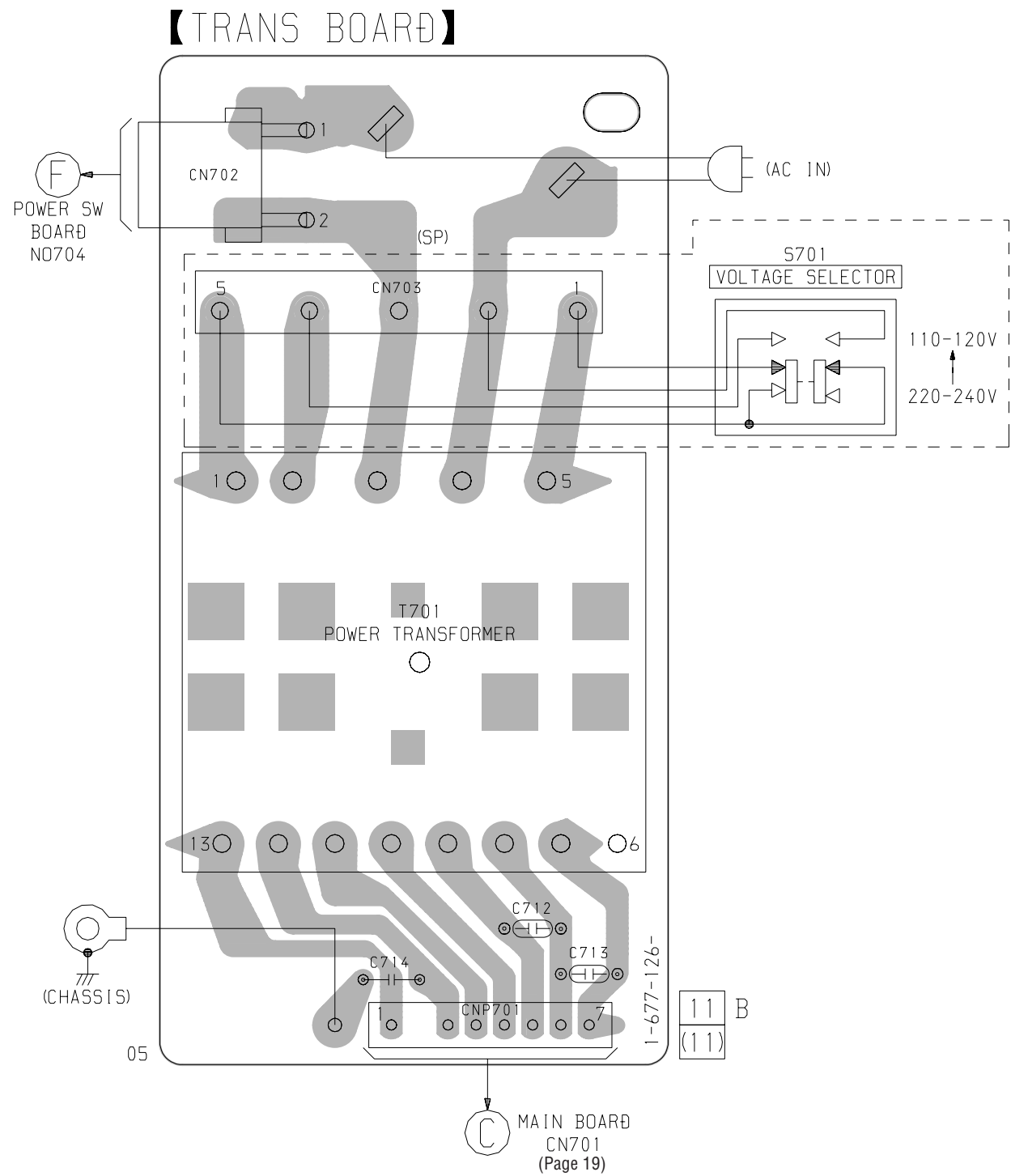

7-7. SCHEMATIC DIAGRAM – TRANS/POWER SW Boards –

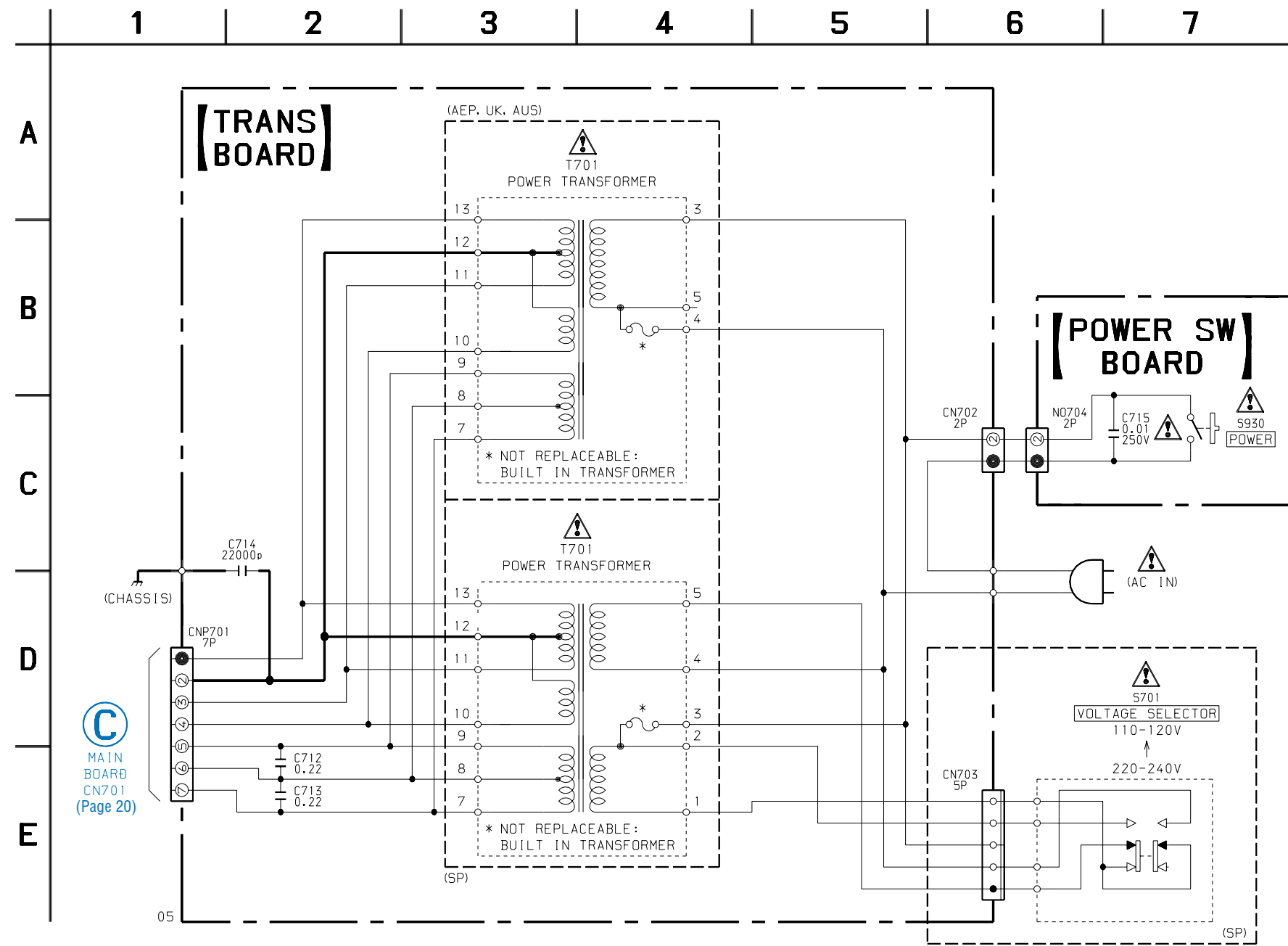

C
MAIN BOARD
CN701
(Page 20)

The components identified by mark Δ or dotted line with mark Δ are critical for safety. Replace only with part number specified.

7-8. PRINTED WIRING BOARD – DISPLAY Board – • See page 16 for Circuit Boards Location.

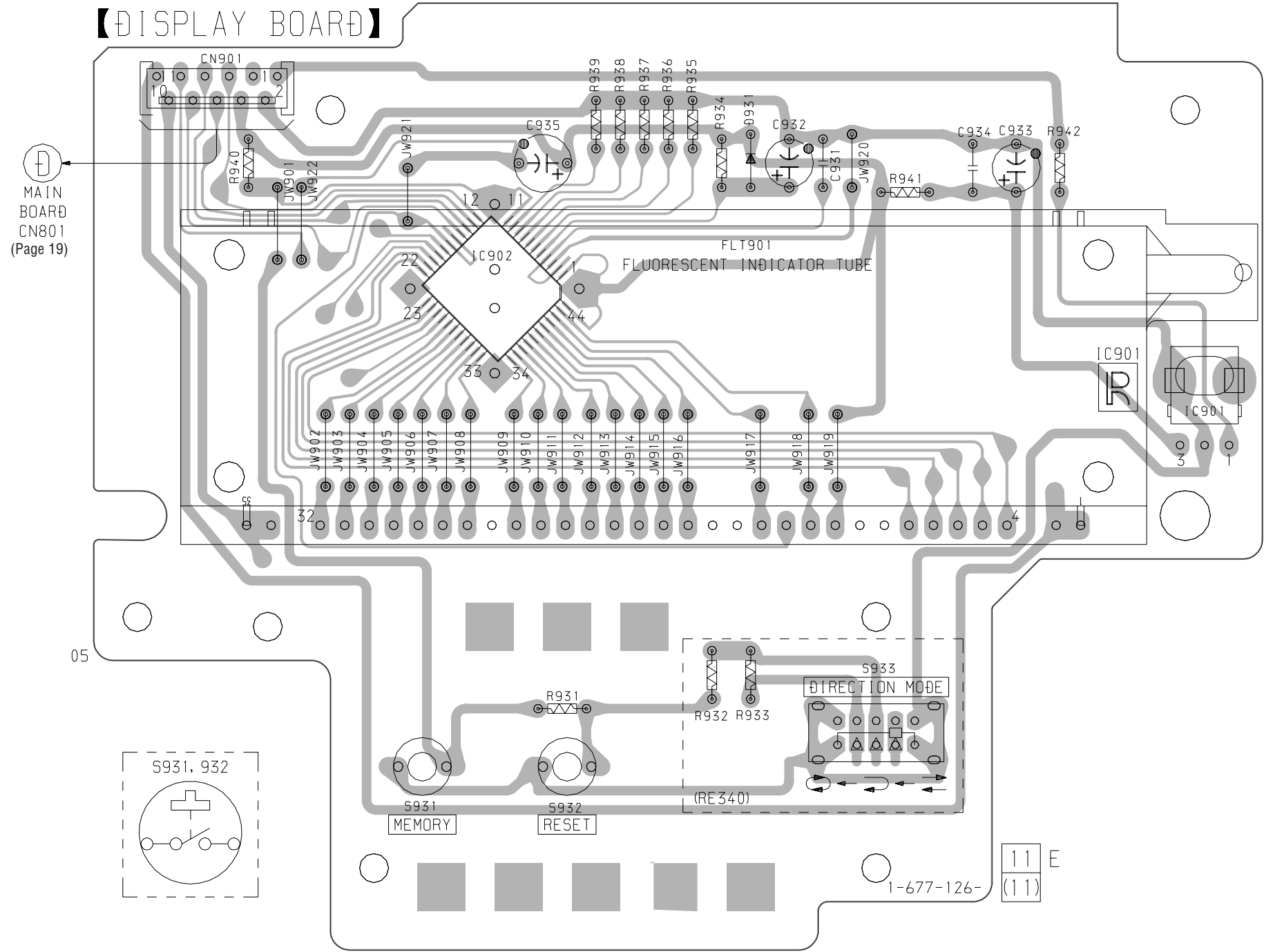

7-9. SCHEMATIC DIAGRAM – DISPLAY Board – • See page 17 for Waveform. • See page 27 for IC Block Diagram.

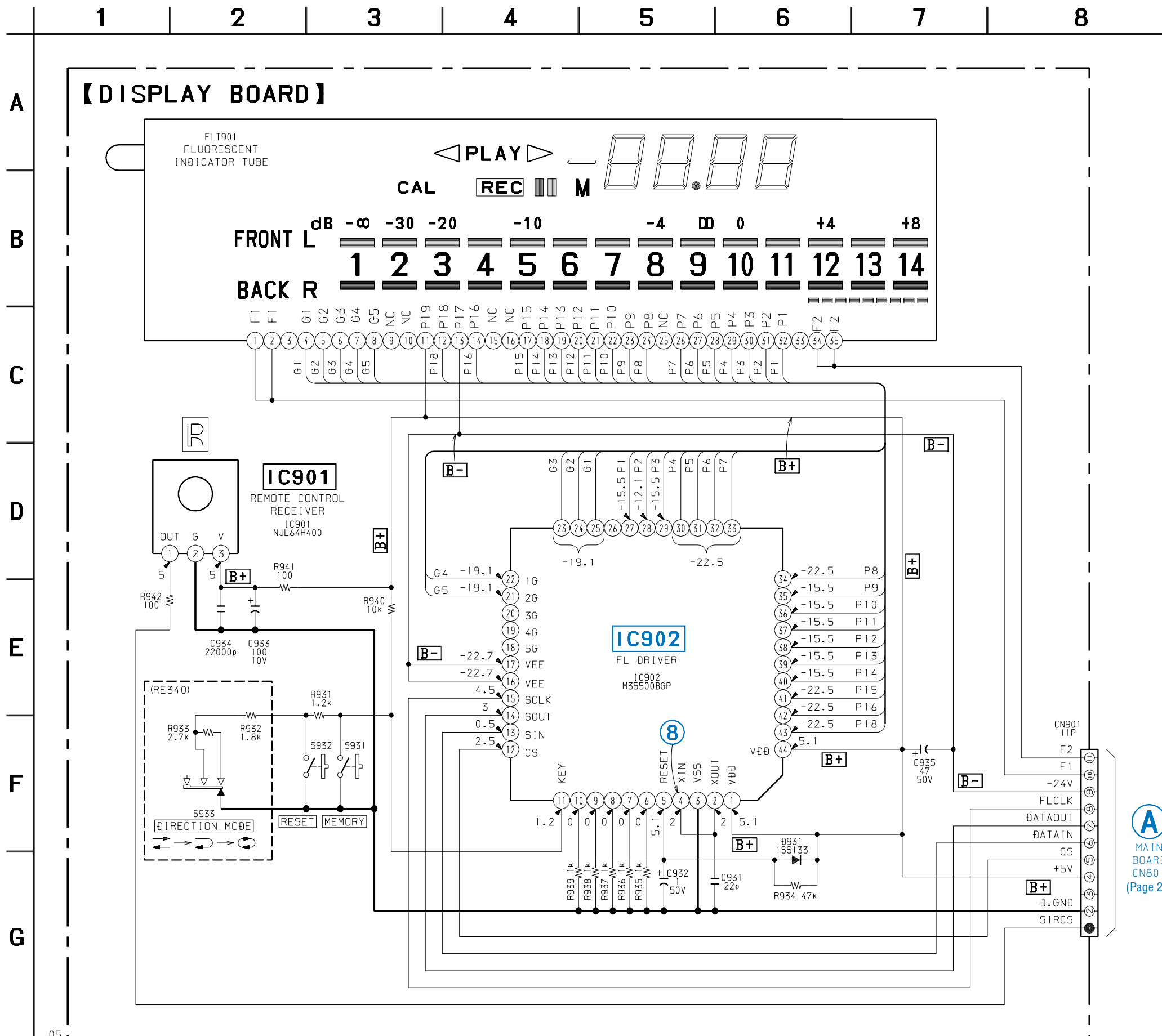

A
MAIN
BOARD
CN801
(Page 20)

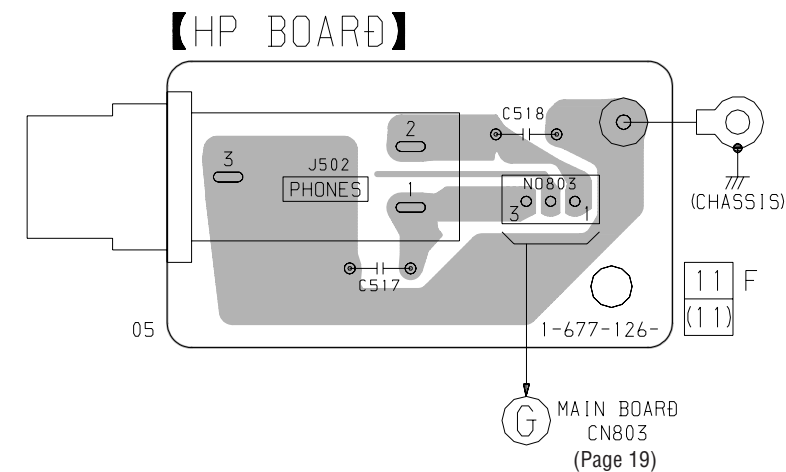
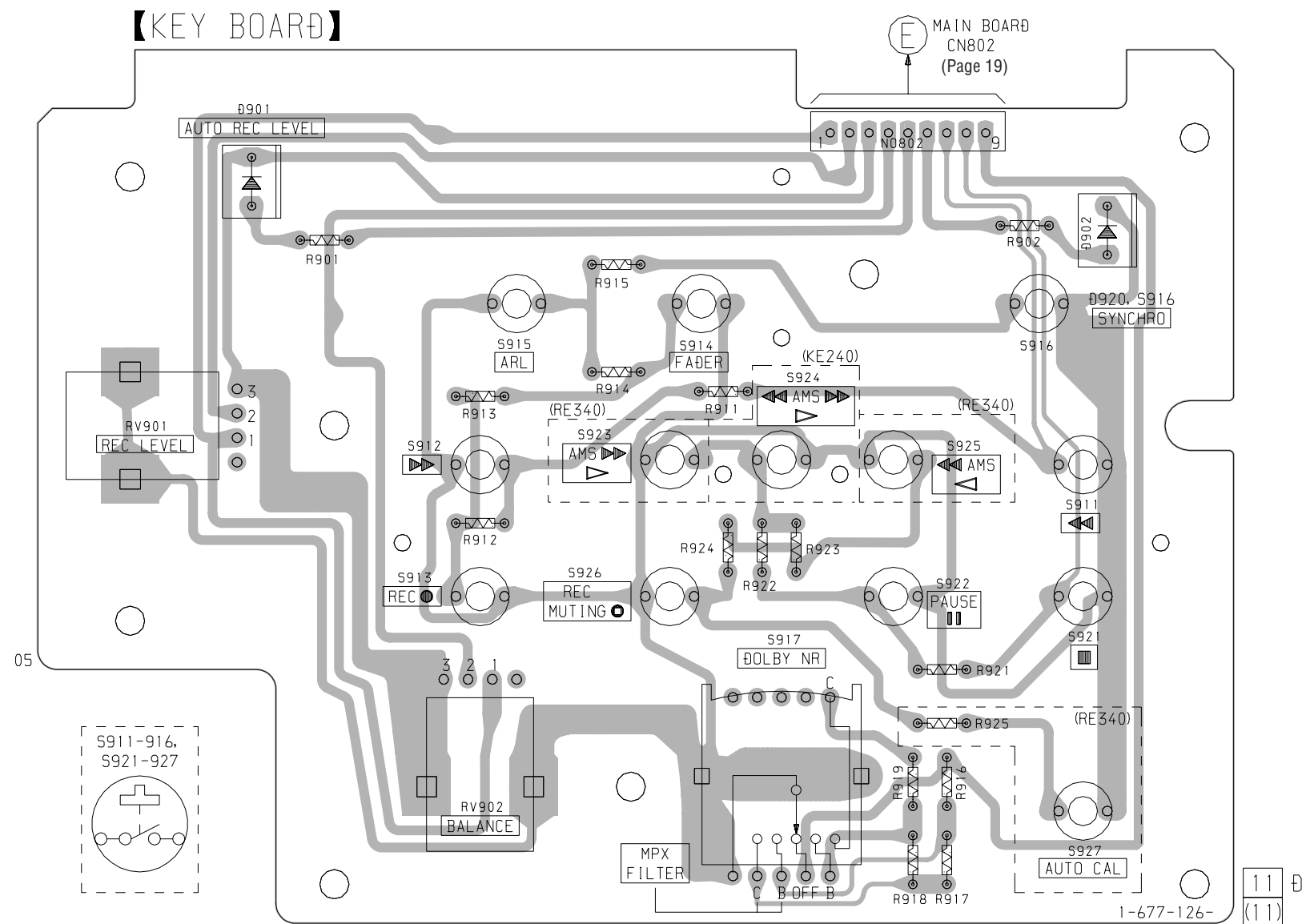

7-11. SCHEMATIC DIAGRAM – KEY Board –

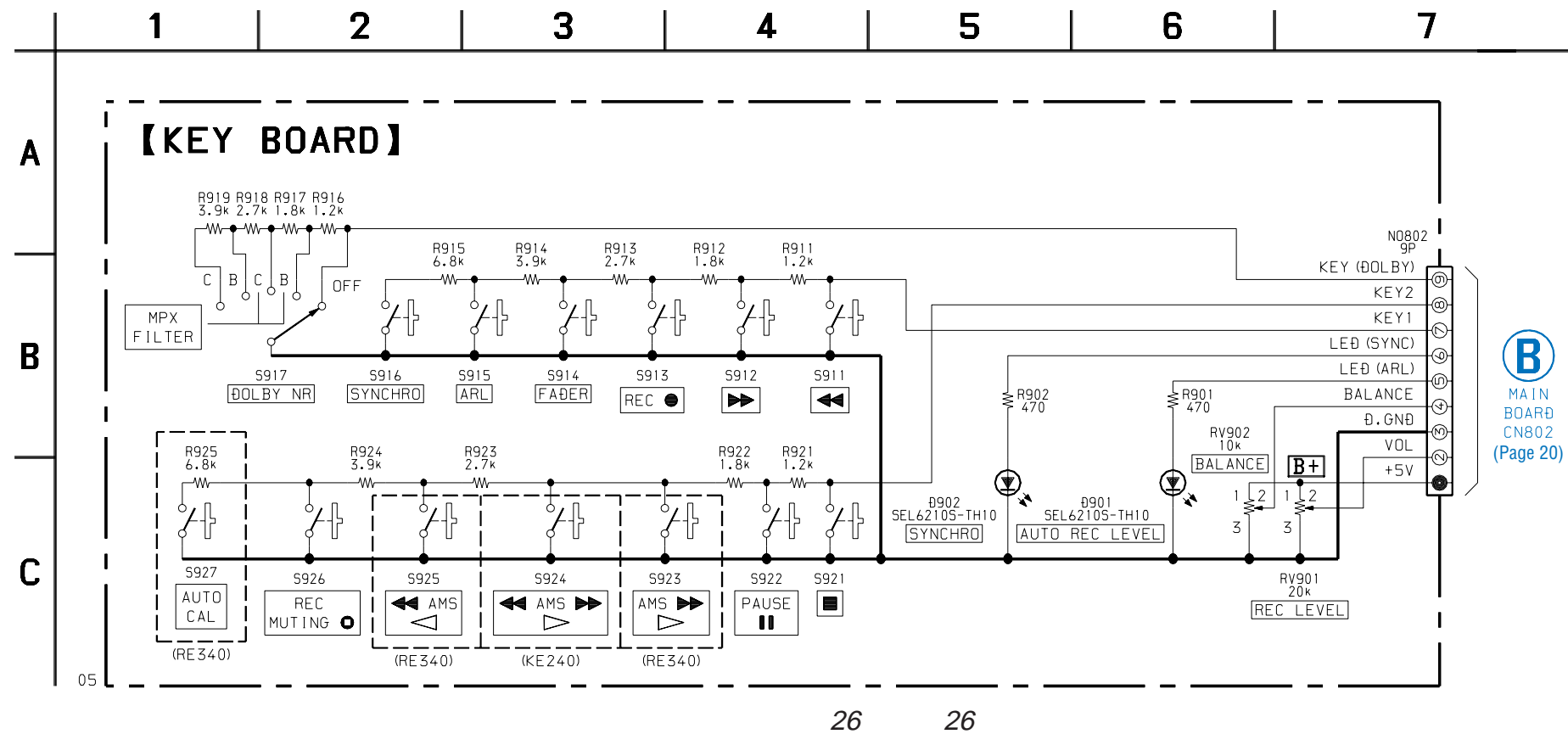

• IC Block Diagrams

IC304 MC14052BCP

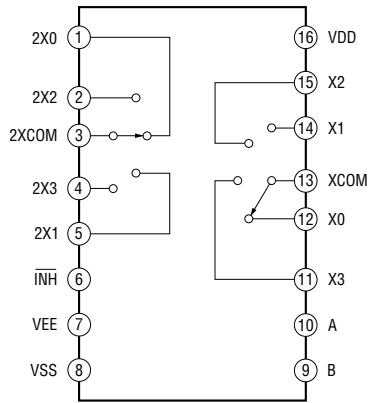

IC902 M35500BGP

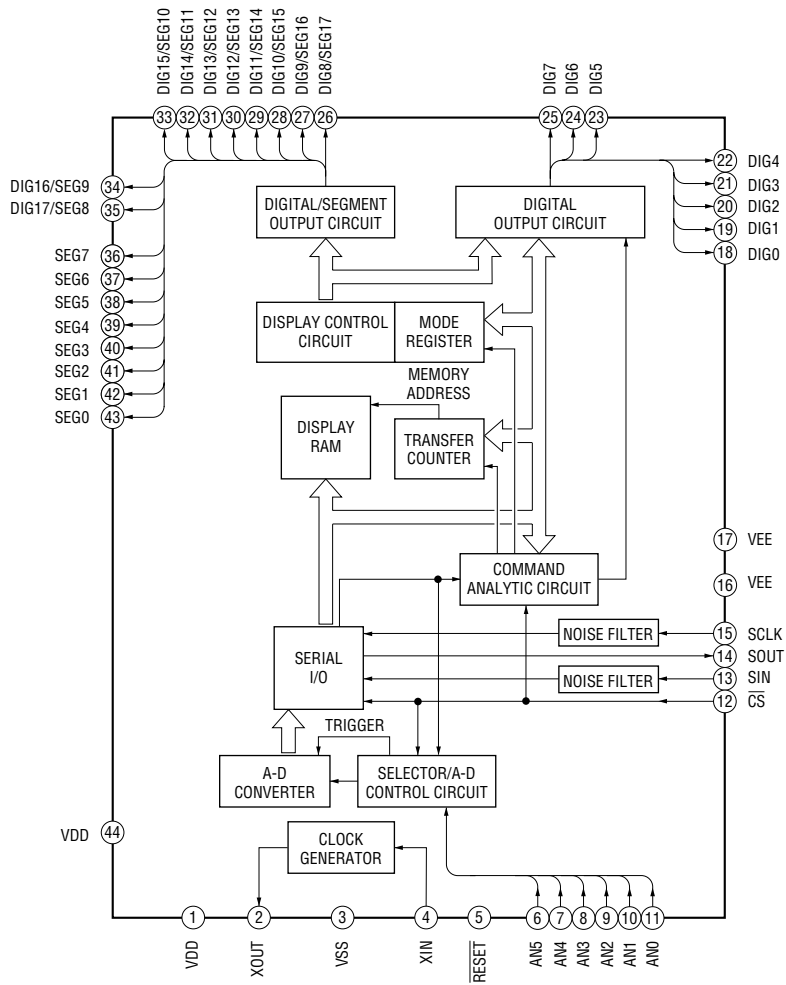

7-12. IC PIN FUNCTION DESCRIPTION

• MAIN BOARD IC801 CXP82220-053Q (SYSTEM CONTROLLER)

Pin No.	Pin Name	I/O	Description
1	PLAYSW B	I	Mechanism playback detect switch (S1002) input terminal “H”: playback
2	70U B	I	CrO ₂ detect switch (S1008) input terminal “H”: CrO ₂
3	METAL	I	Metal detect switch (S1007) input terminal “H”: metal
4	SIRCS IN	I	SIRCS signal input from the remote control receiver (IC901)
5	POWER IN	I	AC in detect signal input terminal “H”: AC in
6	VOL OUT	O	Record level control signal output to the CXA1878Q (IC301)
7	A/B SEL	I	Deck select (A/B) signal input terminal “L”: A deck “H”: B deck Not used (open)
8	CONTROL-A IN	I	SIRCS remote control signal input of the CONTROL A1
9	CONTROL-A OUT	O	SIRCS remote control signal output of the CONTROL A1
10	FLCLK	O	Serial data transfer clock signal output to the M35500BGP (IC902)
11	FLDATA IN	I	Serial data input to the M35500BGP (IC902)
12	FLDATA OUT	O	Serial data output to the M35500BGP (IC902)
13	CS	O	Chip select signal output to the M35500BGP (IC902)
14	REC MUTE A	O	Record muting on/off control signal output terminal “L”: muting on Not used (open)
15	REC/PB	O	Recording/playback control signal output to the CXA1878Q (IC301) “L”: playback, “H”: recording
16	RECCAL 0	O	Recording calibration up/down control signal output to the CXA1878Q (IC301) “L”: down, “H”: up (high impedance: off) (TC-RE340 only) TC-KE240: Not used (open)
17	RECCAL 1	O	
18	GPCAL 0	O	Equalizer calibration up/down control signal output to the CXA1878Q (IC301) “L”: down, “H”: up (high impedance: off) (TC-RE340 only) TC-KE240: Not used (open)
19	GPCAL 1	O	
20	RECCAL 0	O	Recording calibration up/down control signal output terminal “L”: down, “H”: up (high impedance: off) Not used (open)
21	RECCAL 1	O	
22	GPCAL 0	O	Equalizer calibration up/down control signal output terminal “L”: down, “H”: up (high impedance: off) Not used (open)
23	FILTER	O	Multiplex filter on/off control signal output “H”: multiplex filter on
24	REC MUTE B	O	Record muting on/off control signal output to the CXA1878Q (IC301) “L”: muting on
25	CAL OFF	O	Calibration on/off control signal output to the CXA1878Q (IC301) “H”: calibration on (TC-RE340 only) TC-KE240: Not used
26	C/B/OFF	O	Dolby B and C type selection signal output to the CXA1878Q (IC301) “L”: Dolby C, center voltage: Dolby B, “H”: NR off
27	REC EQ HN	O	Recording equalizer select signal output terminal Not used (open)
28	PASS/MUTE/NR	O	Audio select signal output to the CXA1878Q (IC301) “L”: NR on, center voltage: muting, “H”: pass
29	BS/AMS/OFF	O	Mode select signal output for AMS/BS amplifier to the CXA1878Q (IC301) “L”: BS mode, center voltage: AMS mode, “H”: AMS/BS off mode
30	RELAY B	O	Recording/playback switching relay (RY341) control signal output terminal “L”: recording, “H”: playback
31	RELAY A	O	Recording/playback switching relay control signal output terminal “L”: recording, “H”: playback Not used (open)
32	METER L	I	Signal input for the level meter drive (L-ch) from the CXA1878Q (IC301) (A/D input)
33	METER R	I	Signal input for the level meter drive (R-ch) from the CXA1878Q (IC301) (A/D input)
34	HALF	I	Detection input from the cassette detect switch (S1006) “L”: no cassette, “H”: cassette in
35	SHUT	I	Rotation detect signal input of the capstan motor (M1002)
36	KEY2	I	Key input terminal (A/D input) (S911 to S916) ◀▶, REC ●, FADER, ARL, SYNCHRO keys input

Pin No.	Pin Name	I/O	Description
37	KEY1	I	Key input terminal (A/D input) (S921, 922, 924, 926 (TC-KE240) ■, PAUSE ■■, ◀◀ AMS ▶▶, REC MUTING ○ (TC-KE240) keys input, (S921 to S923, S925 to S927) ■, PAUSE ■■, AMS ▶▶ ▷, ◀◀ AMS ◀, REC MUTING ○ (TC-RE340) keys input
38	RESET	I	System reset signal input from the reset signal generator (IC802) “L”: reset “L” is input for several 100 msec after power on, then it changes to “H”
39	EXTAL	I	Main system clock input terminal (10 MHz)
40	XTAL	O	Main system clock output terminal (10 MHz)
41	VSS	—	Ground terminal
42	TX	O	Sub system clock output terminal (32.768 kHz) Not used (pull down)
43	TEX	I	Sub system clock input terminal (32.768 kHz) Not used (fixed at “L”)
44	VOL IN	I	REC LEVEL volume (RV901) input terminal (A/D input)
45	DOLBY SW	I	DOLBY NR switch (S917) input terminal (A/D input)
46	AVREF	—	Reference voltage (+5V) input terminal (for A/D converter)
47	AVSS	—	Ground terminal (for A/D converter)
48	ARL LED	O	LED drive signal output of the AUTO REC LEVEL indicator (D901) “L”: LED on
49	CD SYNC LED	O	LED drive signal output of the SYNCHRO indicator (D902) “L”: LED on
50	CAP M2	O	Capstan motor (M1002) drive signal output terminal
51	CAP M4	O	
52	CAP M3	O	
53	CAP M1	O	
54 to 57	BIAS CAL0 to BIAS CAL3	O	Calibration control signal output terminal
58 to 68	—	—	Not used (open)
69	OSC ON/OFF	O	Calibration OSC on/off control signal output terminal
70	OSC H/L	O	Calibration tone frequency high/low control signal output terminal “L”: frequency low
71	LINE MUTE	O	Line muting on/off control signal output terminal “L”: muting on
72 to 87	—	—	Not used (open)
88	VF	—	Power supply terminal (for FDP) Not used (fixed at “L”)
89	VDD	—	Power supply terminal (+5V)
90	NC	—	Not used (fixed at “L”)
91	VSS	—	Ground terminal
92	BIAS A	O	Recording bias on/off control signal output terminal “L”: bias on Not used (open)
93	BIAS	O	Recording bias on/off control signal output terminal “L”: bias on
94	VERSION	I	Setting terminal for the model type
95	AMS IN	I	Auto music sensor signal input terminal “L”: AMS detect
96	TRG B	O	Plunger (PM1001) drive signal output terminal
97	TRG A	O	Plunger drive signal output terminal Not used (open)
98	—	—	
99	PLAYSW A	I	Mechanism playback detect signal input terminal “H”: playback Not used (open)
100	70U A	I	CrO ₂ detect signal input terminal “H”: CrO ₂ Not used (fixed at “L”)

SECTION 8 EXPLODED VIEWS

NOTE:

- -XX and -X mean standardized parts, so they may have some difference from the original one.
- Color Indication of Appearance Parts
Example:
KNOB, BALANCE (WHITE) . . . (RED)
 ↑ ↑
 Parts Color Cabinet's Color
- Abbreviation
AUS : Australian model
SP : Singapore model

- Items marked “*” are not stocked since they are seldom required for routine service. Some delay should be anticipated when ordering these items.
- The mechanical parts with no reference number in the exploded views are not supplied.
- Hardware (# mark) list and accessories and packing materials are given in the last of the electrical parts list.

The components identified by mark Δ or dotted line with mark Δ are critical for safety. Replace only with part number specified.

(1) CHASSIS SECTION

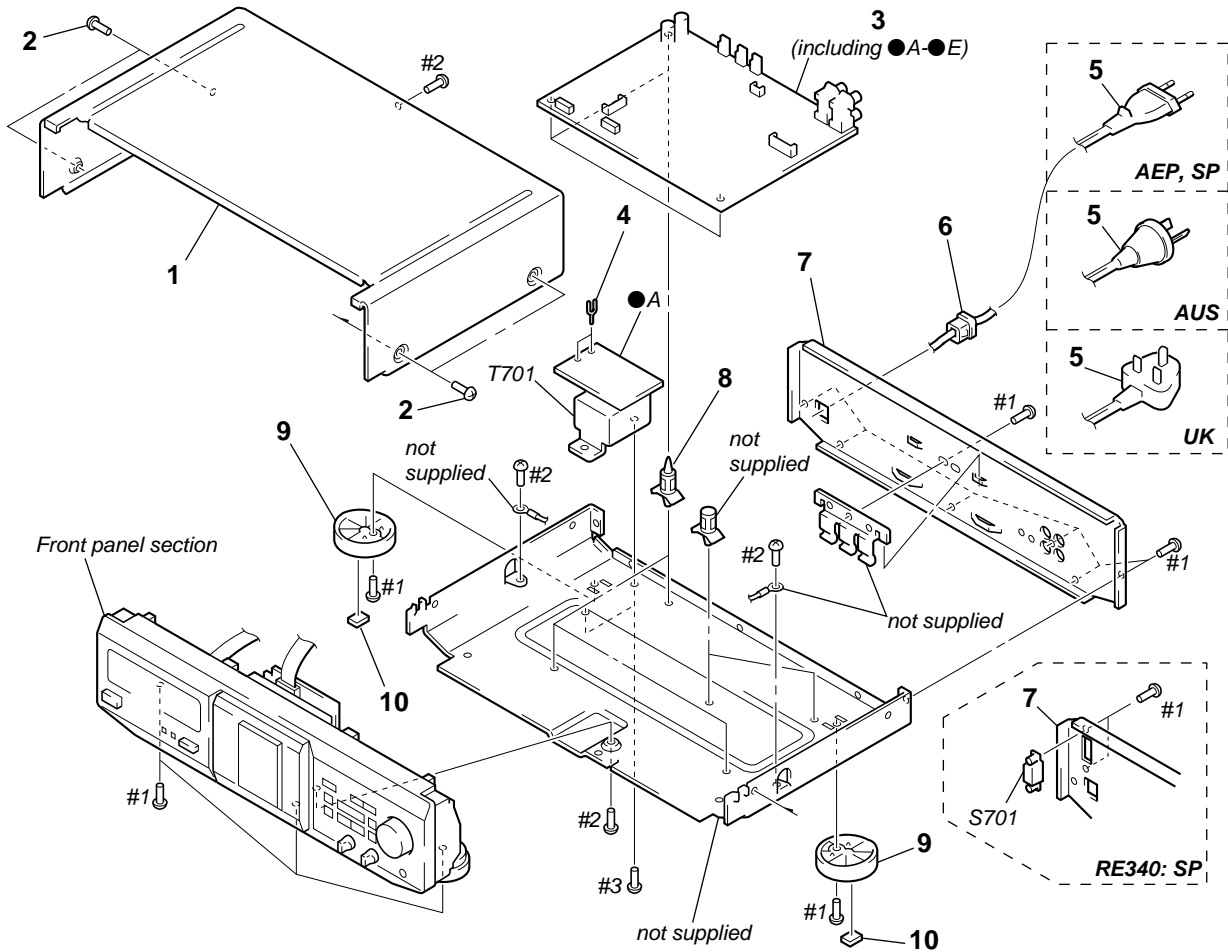

Ref. No.	Part No.	Description	Remark	Ref. No.	Part No.	Description	Remark
* 1	3-935-634-01	CASE (410726) (BLACK)		6	4-966-267-12	BUSHING (FBS001), CORD	
1	3-935-634-11	CASE (410726) (SILVER)		7	3-042-490-01	PANEL, BACK (RE340: AEP)	
2	3-363-099-01	SCREW (CASE 3 TP2) (BLACK)		7	3-042-490-11	PANEL, BACK (RE340: AUS)	
2	4-210-291-11	SCREW (CASE 3 TP2) (SILVER)		7	3-042-490-21	PANEL, BACK (RE340: SP)	
3	A-2007-842-A	MAIN BOARD, COMPLETE (RE340: AEP (BLACK), AUS)		7	3-042-502-01	PANEL, BACK (KE240: AEP)	
3	A-2007-843-A	MAIN BOARD, COMPLETE (RE340: SP)		7	3-042-502-11	PANEL, BACK (KE240: UK)	
3	A-2007-844-A	MAIN BOARD, COMPLETE (KE240)		* 8	3-346-265-31	HOLDER, PC BOARD	
3	A-2007-847-A	MAIN BOARD, COMPLETE (RE340: AEP (SILVER))		9	4-977-591-11	FOOT (F50150S) (BLACK)	
* 4	1-535-688-11	TERMINAL		9	4-977-591-71	FOOT (F50150S) (SILVER)	
Δ 5	1-751-535-11	CORD, POWER (UK)		* 10	4-978-398-21	CUSHION	
Δ 5	1-777-107-11	CORD, POWER (AEP, SP)		Δ S701	1-570-046-21	SWITCH, VOLTAGE CHANGE (VOLTAGE SELECTOR) (RE340: SP)	
Δ 5	1-777-218-11	CORD, POWER (AUS)		Δ T701	1-426-651-21	TRANSFORMER, POWER (AEP, UK, AUS)	
				Δ T701	1-426-652-21	TRANSFORMER, POWER (SP)	

(2) FRONT PANEL SECTION

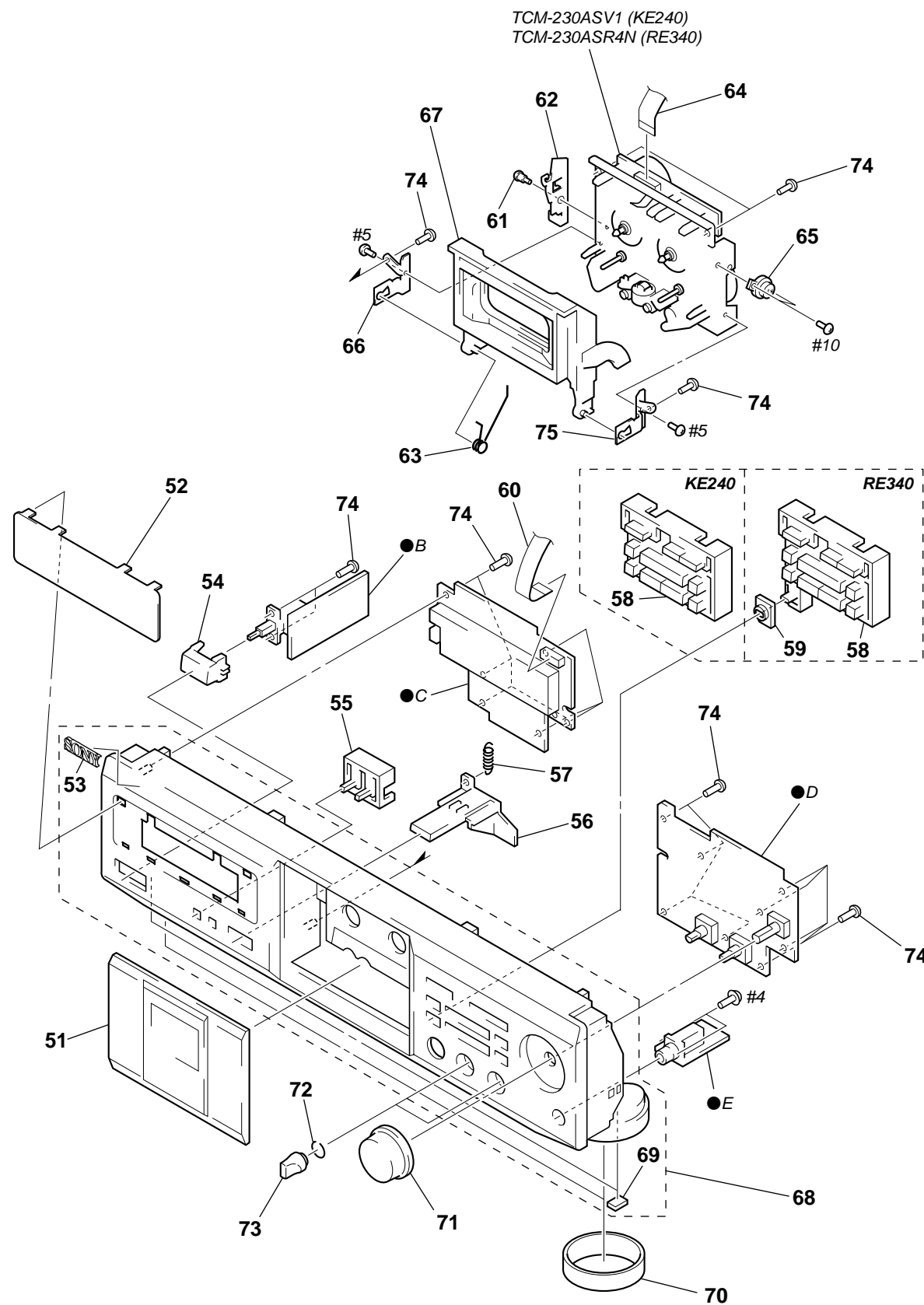

Ref. No.	Part No.	Description	Remark	Ref. No.	Part No.	Description	Remark
51	X-3378-305-2	LID (CASSETTE) ASSY (BLACK)		62	3-019-452-01	LEVER (LOCK L)	
51	X-3378-307-2	LID (CASSETTE) ASSY (KE240)		63	3-019-454-01	SPRING (L), LOADING	
51	X-4952-829-2	LID (CASSETTE) ASSY (SILVER)		64	1-769-976-11	WIRE (FLAT TYPE) (13 CORE)	
52	3-042-497-01	WINDOW (METER)		65	3-022-410-01	DAMPER	
53	4-996-698-41	EMBLEM, SONY		66	3-019-450-01	PLATE (L), FULCRUM	
54	3-931-429-21	BUTTON (POWER) (BLACK)		67	X-3375-107-1	HOLDER (L) ASSY, CASSETTE (BLACK)	
54	4-227-979-01	BUTTON (POWER) (SILVER)		67	X-4952-717-1	HOLDER (L) ASSY, CASSETTE (SILVER)	
55	3-042-493-01	BUTTON (MEMORY) (BLACK)		68	X-3378-304-2	PANEL ASSY, FRONT (BLACK) (RE340)	
55	3-042-493-11	BUTTON (MEMORY) (SILVER)		68	X-3378-306-2	PANEL ASSY, FRONT (KE240)	
56	3-042-494-01	BUTTON (EJECT) (BLACK)		68	X-4952-828-2	PANEL ASSY, FRONT (SILVER) (RE340)	
56	3-042-494-11	BUTTON (EJECT) (SILVER)		* 69	4-978-398-21	CUSHION	
57	3-042-501-01	SPRING, TENSION		70	4-977-593-01	RING (DIA. 50), ORNAMENTAL	
58	3-042-492-01	BUTTON (FWD) (KE240)		71	3-042-495-01	KNOB (REC) (BLACK)	
58	3-042-500-01	BUTTON (REV) (BLACK)		71	3-042-495-11	KNOB (REC) (SILVER)	
58	3-042-500-21	BUTTON (REV) (SILVER)		72	3-354-981-01	SPRING (SUS), RING	
59	3-042-500-11	BUTTON (REV) (BLACK)		73	3-042-496-01	KNOB (BALANCE) (BLACK)	
59	3-042-500-31	BUTTON (REV) (SILVER)		73	3-042-496-11	KNOB (BALANCE) (SILVER)	
60	1-769-948-11	WIRE (FLAT TYPE) (11 CORE)		74	4-951-620-01	SCREW (2.6X8), +BVTP	
61	3-019-456-01	SCREW, STEP		75	3-019-451-01	PLATE (R), FULCRUM	

(3) MECHANISM DECK SECTION-1
(TCM-230ASV1) (KE240)

(4) MECHANISM DECK SECTION-2
(TCM-230ASR4N) (RE340)

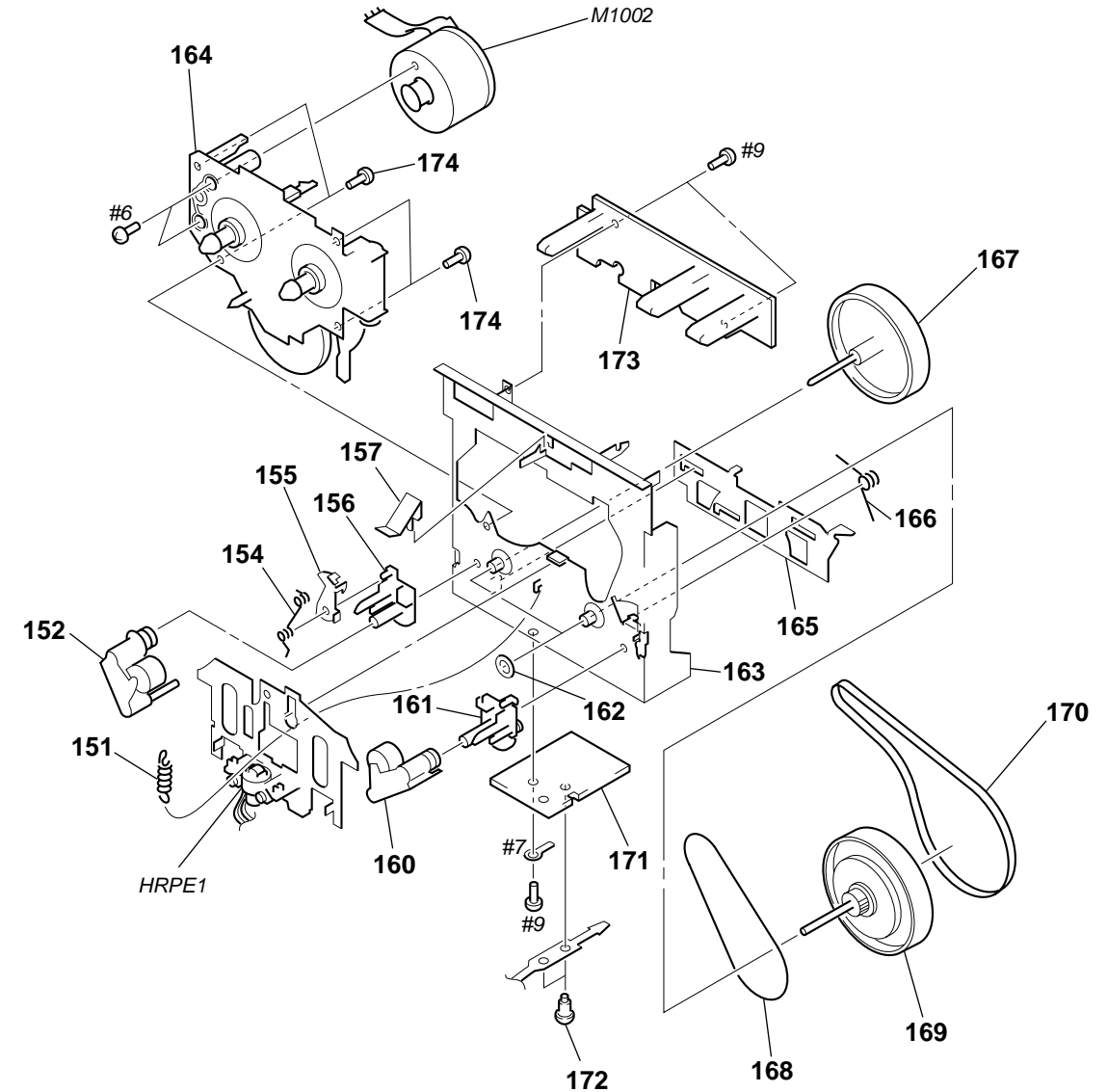
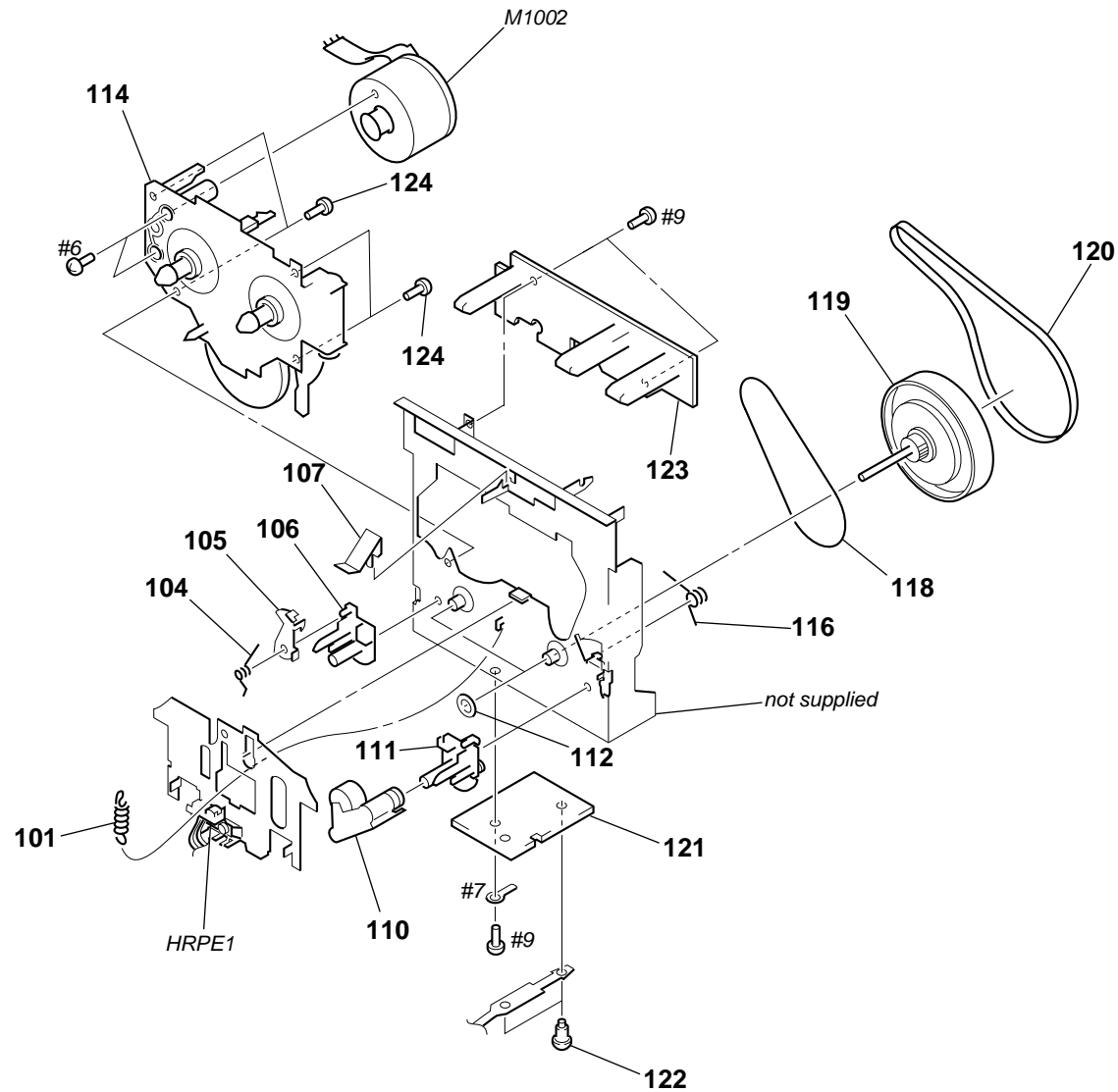

Ref. No.	Part No.	Description	Remark	Ref. No.	Part No.	Description	Remark
101	3-016-574-11	SPRING (HEAD), TENSION		118	3-024-405-01	BELT (FR2)	
104	3-016-576-01	SPRING, TORSION		119	X-3376-932-2	FLYWHEEL (FWD) ASSY	
105	3-016-572-01	LEVER (EJECT PREVENTION L)		120	3-016-570-01	BELT (CAPSTAN)	
106	3-016-565-01	BASE (PINCH LEVER REV)		* 121	1-668-635-11	HEAD RELAY (REC/PB) BOARD	
107	3-016-567-02	SPRING (CASSETTE), LEAF		122	3-911-116-42	RIVET, PUSH	
110	X-3374-155-4	PINCH LEVER (FWD) ASSY		* 123	1-668-628-11	LEAF SW (REC/PB) BOARD	
111	3-016-564-01	BASE (PINCH LEVER FWD)		124	3-030-823-01	SCREW (+BVTT) (2X3.5)	
112	3-019-208-01	WASHER, STOPPER		HRPE1	A-2004-774-A	BASE ASSY, HEAD	
114	A-2004-699-A	MECHANICAL BLOCK ASSY (AMS)				(RECORD/PLAYBACK/ERASE)	
116	3-016-575-11	SPRING, TORSION		M1002	A-2004-644-A	MOTOR ASSY, CAPSTAN	

Ref. No.	Part No.	Description	Remark	Ref. No.	Part No.	Description	Remark
151	3-016-574-11	SPRING (HEAD), TENSION		166	3-016-575-11	SPRING, TORSION	
152	X-3374-156-4	PINCH LEVER (REV) ASSY		167	X-3376-933-1	FLYWHEEL (REV) ASSY	
154	3-032-809-02	SPRING (L), TORSION		168	3-024-405-01	BELT (FR2)	
155	3-016-572-01	LEVER (EJECT PREVENTION L)		169	X-3376-932-2	FLYWHEEL (FWD) ASSY	
156	3-016-565-01	BASE (PINCH LEVER REV)		170	3-016-570-01	BELT (CAPSTAN)	
157	3-016-567-02	SPRING (CASSETTE), LEAF		* 171	1-668-635-11	HEAD RELAY (REC/PB) BOARD	
160	X-3374-155-4	PINCH LEVER (FWD) ASSY		172	3-911-116-42	RIVET, PUSH	
161	3-016-564-01	BASE (PINCH LEVER FWD)		* 173	1-668-628-11	LEAF SW (REC/PB) BOARD	
162	3-019-208-01	WASHER, STOPPER		174	3-030-823-01	SCREW (+BVTT) (2X3.5)	
* 163	X-3374-828-3	CHASSIS ASSY, MECHANICAL		HRPE1	A-2004-646-D	DECK ASSY, HEAD	
						(RECORD/PLAYBACK/ERASE)	
164	A-2004-699-A	MECHANICAL BLOCK ASSY (AMS)		M1002	A-2004-644-A	MOTOR ASSY, CAPSTAN	
165	3-016-566-01	SLIDER, REVERSE					

SECTION 9 ELECTRICAL PARTS LIST

HEAD RELAY (REC/PB)

LEAF SW (REC/PB)

**MAIN
DISPLAY, HP, KEY, POWER SW, TRANS**

NOTE:

- Due to standardization, replacements in the parts list may be different from the parts specified in the diagrams or the components used on the set.
- -XX and -X mean standardized parts, so they may have some difference from the original one.
- RESISTORS
All resistors are in ohms.
METAL: Metal-film resistor.
METAL OXIDE: Metal oxide-film resistor.
F: nonflammable
- Abbreviation
AUS : Australian model
SP : Singapore model
- Items marked “*” are not stocked since they are seldom required for routine service. Some delay should be anticipated when ordering these items.
- SEMICONDUCTORS
In each case, u: μ , for example:
uA. . : μ A. . uPA. . : μ PA. .
uPB. . : μ PB. . uPC. . : μ PC. .
uPD. . : μ PD. .
- CAPACITORS
uF: μ F
- COILS
uH: μ H

The components identified by mark Δ or dotted line with mark Δ are critical for safety. Replace only with part number specified.

When indicating parts by reference number, please include the board.

Ref. No.	Part No.	Description	Remark	Ref. No.	Part No.	Description	Remark
*	1-668-635-11	HEAD RELAY (REC/PB) BOARD *****			A-2007-842-A	MAIN BOARD, COMPLETE (RE340: AEP (BLACK), AUS)	
		< CONNECTOR >			A-2007-843-A	MAIN BOARD, COMPLETE (RE340: SP)	
	CN1003	1-564-722-11 PIN, CONNECTOR (SMALL TYPE) 6P *****			A-2007-844-A	MAIN BOARD, COMPLETE (KE240)	
					A-2007-847-A	MAIN BOARD, COMPLETE (RE340: AEP (SILVER)) *****	
						(Including mounted DISPLAY, HP, KEY, POWER SW and TRANS boards)	
*	1-668-628-11	LEAF SW (REC/PB) BOARD *****		*	3-377-337-11	HOLDER (FL) < CAPACITOR >	
		< CONNECTOR >			C101	1-162-284-31 CERAMIC 150PF 10% 50V	
	CN1001	1-568-444-11 SOCKET, CONNECTOR 13P < DIODE >			C102	1-126-961-11 ELECT 2.2uF 20% 50V	
	D1001	8-719-991-33 DIODE 1SS133T-77 < PHOTO INTERRUPTER >			C103	1-162-600-11 CERAMIC 0.0047uF 30% 16V	
					C104	1-126-963-11 ELECT 4.7uF 20% 50V	
	IC1002	8-749-014-38 PHOTO INTERRUPTER SG-264 < RESISTOR >			C105	1-162-302-11 CERAMIC 0.0022uF 20% 16V	
	R1002	1-249-409-11 CARBON 220 5% 1/4W			C106	1-126-963-11 ELECT 4.7uF 20% 50V	
	R1003	1-249-414-11 CARBON 560 5% 1/4W			C107	1-126-964-11 ELECT 10uF 20% 50V	
	R1004	1-247-834-11 CARBON 1.3K 5% 1/4W			C108	1-130-495-00 MYLAR 0.1uF 5% 50V	
	R1005	1-247-818-91 CARBON 300 5% 1/4W (RE340)			C109	1-137-375-11 MYLAR 0.068uF 5% 50V	
		< SWITCH >			C110	1-126-964-11 ELECT 10uF 20% 50V	
	S1002	1-570-953-11 SWITCH, PUSH (1 KEY) (PLAY SWITCH)			C111	1-126-959-11 ELECT 0.47uF 20% 50V	
	S1005	1-771-205-11 SWITCH, LEAF (REC PROOF (SIDE A))			C112	1-126-963-11 ELECT 4.7uF 20% 50V	
	S1006	1-771-333-11 SWITCH, LEAF (HALF DETECT)			C113	1-126-963-11 ELECT 4.7uF 20% 50V	
	S1007	1-771-205-11 SWITCH, LEAF (METAL DETECT)			C114	1-126-961-11 ELECT 2.2uF 20% 50V	
	S1008	1-771-205-11 SWITCH, LEAF (CrO2 DETECT)			C115	1-137-436-11 MYLAR 0.0039uF 5% 50V	
	S1009	1-771-205-11 SWITCH, LEAF (REC PROOF (SIDE B)) (RE340) *****			C120	1-162-289-31 CERAMIC 390PF 10% 50V	
					C121	1-162-294-31 CERAMIC 0.001uF 10% 50V	
					C122	1-162-282-31 CERAMIC 100PF 10% 50V	
					C123	1-137-372-11 MYLAR 0.022uF 5% 50V	
					C124	1-126-963-11 ELECT 4.7uF 20% 50V	
					C141	1-162-288-31 CERAMIC 330PF 10% 50V	
					C142	1-107-609-11 CERAMIC 75PF 5% 500V	
					C143	1-130-472-00 MYLAR 0.0012uF 5% 50V (RE340)	
					C144	1-102-973-00 CERAMIC 100PF 5% 50V (RE340)	
					C145	1-136-356-11 FILM 470PF 5% 100V (RE340)	
					C146	1-137-374-11 MYLAR 0.047uF 5% 50V (RE340)	
					C147	1-161-494-00 CERAMIC 0.022uF 25V (RE340)	

MAIN

DISPLAY, HP, KEY, POWER SW, TRANS

Ref. No.	Part No.	Description			Remark	Ref. No.	Part No.	Description			Remark
C148	1-162-306-11	CERAMIC	0.01uF	30%	16V (RE340)	C316	1-126-960-11	ELECT	1uF	20%	50V (KE240)
C149	1-162-280-31	CERAMIC	82PF	10%	50V (KE240)	C317	1-126-767-11	ELECT	1000uF	20%	16V (RE340)
C201	1-162-284-31	CERAMIC	150PF	10%	50V	C317	1-126-768-11	ELECT	2200uF	20%	16V (KE240)
C202	1-126-961-11	ELECT	2.2uF	20%	50V	C321	1-104-664-11	ELECT	47uF	20%	25V
C203	1-162-600-11	CERAMIC	0.0047uF	30%	16V	C322	1-104-664-11	ELECT	47uF	20%	25V
C204	1-126-963-11	ELECT	4.7uF	20%	50V	C331	1-104-664-11	ELECT	47uF	20%	16V (RE340)
C205	1-162-302-11	CERAMIC	0.0022uF	20%	16V	C332	1-107-584-11	CERAMIC	4PF	0.25PF	500V (RE340)
C206	1-126-963-11	ELECT	4.7uF	20%	50V	C333	1-126-965-11	ELECT	22uF	20%	50V (RE340)
C207	1-126-964-11	ELECT	10uF	20%	50V	C334	1-126-959-11	ELECT	0.47uF	20%	50V (RE340)
C208	1-130-495-00	MYLAR	0.1uF	5%	50V	C341	1-126-964-11	ELECT	10uF	20%	50V
C209	1-137-375-11	MYLAR	0.068uF	5%	50V	C351	1-137-457-11	MYLAR	0.0027uF	5%	50V (RE340)
C210	1-126-964-11	ELECT	10uF	20%	50V	C352	1-130-494-11	MYLAR	0.082uF	5%	50V (RE340)
C211	1-126-959-11	ELECT	0.47uF	20%	50V	C353	1-137-374-11	MYLAR	0.047uF	5%	50V (RE340)
C212	1-126-963-11	ELECT	4.7uF	20%	50V	C354	1-137-366-11	MYLAR	0.0022uF	5%	50V (RE340)
C213	1-126-963-11	ELECT	4.7uF	20%	50V	C355	1-136-168-00	MYLAR	0.18uF	5%	50V
C214	1-126-961-11	ELECT	2.2uF	20%	50V	C356	1-137-150-11	MYLAR	0.01uF	5%	50V
C215	1-137-436-11	MYLAR	0.0039uF	5%	50V	C357	1-136-175-00	MYLAR	0.68uF	5%	50V
C220	1-162-289-31	CERAMIC	390PF	10%	50V	C361	1-161-494-00	CERAMIC	0.022uF		25V
C221	1-162-294-31	CERAMIC	0.001uF	10%	50V	C511	1-126-916-11	ELECT	1000uF	20%	6.3V
C222	1-162-282-31	CERAMIC	100PF	10%	50V	C517	1-162-294-31	CERAMIC	0.001uF	10%	50V
C223	1-137-372-11	MYLAR	0.022uF	5%	50V	C518	1-162-294-31	CERAMIC	0.001uF	10%	50V
C224	1-126-963-11	ELECT	4.7uF	20%	50V	C601	1-164-159-11	CERAMIC	0.1uF		50V
C241	1-162-288-31	CERAMIC	330PF	10%	50V	C701	1-126-943-11	ELECT	2200uF	20%	25V
C242	1-107-609-11	CERAMIC	75PF	5%	500V	C702	1-126-943-11	ELECT	2200uF	20%	25V
C243	1-130-472-00	MYLAR	0.0012uF	5%	50V (RE340)	C703	1-126-963-11	ELECT	4.7uF	20%	50V
C244	1-102-973-00	CERAMIC	100PF	5%	50V (RE340)	C704	1-126-968-11	ELECT	100uF	20%	50V
C245	1-136-356-11	FILM	470PF	5%	100V (RE340)	C705	1-104-664-11	ELECT	47uF	20%	25V
C246	1-137-374-11	MYLAR	0.047uF	5%	50V (RE340)	C706	1-126-926-11	ELECT	1000uF	20%	10V
C247	1-161-494-00	CERAMIC	0.022uF		25V (RE340)	C707	1-126-926-11	ELECT	1000uF	20%	10V
C248	1-162-306-11	CERAMIC	0.01uF	30%	16V (RE340)	C708	1-126-964-11	ELECT	10uF	20%	50V
C249	1-162-280-31	CERAMIC	82PF	10%	50V (KE240)	C709	1-164-159-11	CERAMIC	0.1uF		50V
C301	1-126-964-11	ELECT	10uF	20%	50V	C710	1-126-935-11	ELECT	470uF	20%	6.3V
C302	1-126-964-11	ELECT	10uF	20%	50V	C711	1-126-947-11	ELECT	47uF	20%	35V
C303	1-126-964-11	ELECT	10uF	20%	50V	C712	1-136-169-00	MYLAR	0.22uF	5%	50V
C304	1-126-960-11	ELECT	1uF	20%	50V	C713	1-136-169-00	MYLAR	0.22uF	5%	50V
C305	1-136-173-00	MYLAR	0.47uF	5%	50V	C714	1-161-494-00	CERAMIC	0.022uF		25V
C306	1-130-497-00	MYLAR	0.15uF	5%	50V	△ C715	1-113-925-11	CERAMIC	0.01uF	20%	250V
C307	1-126-960-11	ELECT	1uF	20%	50V	C801	1-104-665-11	ELECT	100uF	20%	10V
C308	1-126-959-11	ELECT	0.47uF	20%	50V (RE340)	C802	1-161-494-00	CERAMIC	0.022uF		25V
C309	1-126-965-11	ELECT	22uF	20%	50V	C803	1-126-959-11	ELECT	0.47uF	20%	50V
C310	1-136-293-11	FILM	0.0082uF	5%	100V	C810	1-161-494-00	CERAMIC	0.022uF		25V
C311	1-126-960-11	ELECT	1uF	20%	50V	C811	1-164-159-11	CERAMIC	0.1uF		50V
C312	1-130-299-00	MYLAR	0.012uF	5%	50V (RE340)	C931	1-162-207-31	CERAMIC	22PF	5%	50V
C312	1-137-150-11	MYLAR	0.01uF	5%	50V (KE240)	C932	1-126-960-11	ELECT	1uF	20%	50V
C313	1-137-436-11	MYLAR	0.0039uF	5%	50V	C933	1-104-665-11	ELECT	100uF	20%	10V
C314	1-137-436-11	MYLAR	0.0039uF	5%	50V	C934	1-161-494-00	CERAMIC	0.022uF		25V
C315	1-126-964-11	ELECT	10uF	20%	50V	C935	1-126-967-11	ELECT	47uF	20%	50V

The components identified by mark △ or dotted line with mark △ are critical for safety.
Replace only with part number specified.

MAIN
DISPLAY, HP, KEY, POWER SW, TRANS

Ref. No.	Part No.	Description	Remark	Ref. No.	Part No.	Description	Remark
		< CONNECTOR >					
CN301	1-691-770-11	PLUG (MICRO CONNECTOR) 8P		* J601	1-764-188-11	JACK (SMALL TYPE) (DIA. 3.5) (CONTROL A1 II (IN))	
CN302	1-784-774-11	CONNECTOR, FFC 13P		* J602	1-764-188-11	JACK (SMALL TYPE) (DIA. 3.5) (CONTROL A1 II (OUT))	
CN701	1-691-769-11	PLUG (MICRO CONNECTOR) 7P				< COIL >	
* CN702	1-568-226-11	PIN, CONNECTOR 2P					
* CN703	1-573-565-11	PIN, CONNECTOR 5P (RE340: SP)		L141	1-410-780-11	INDUCTOR 27mH	
				L241	1-410-780-11	INDUCTOR 27mH	
CN801	1-568-830-11	CONNECTOR, FFC 11P				< LOW PASS FILTER >	
* CN802	1-568-936-11	PIN, CONNECTOR 9P		LPF101	1-233-271-11	FILTER, LOW PASS	
CN803	1-506-468-11	PIN, CONNECTOR 3P		LPF201	1-233-271-11	FILTER, LOW PASS	
CN901	1-568-830-11	CONNECTOR, FFC 11P				< TRANSISTOR >	
		< DIODE >					
D341	8-719-911-19	DIODE 1SS133T-72		Q101	8-729-029-94	TRANSISTOR DTC143TSA-TP	
D351	8-719-911-19	DIODE 1SS133T-72 (RE340)		Q102	8-729-142-25	TRANSISTOR 2SD1020TP-HFE	
D352	8-719-911-19	DIODE 1SS133T-72 (RE340)		Q104	8-729-030-02	TRANSISTOR DTC144ESA-TP	
D601	8-719-911-19	DIODE 1SS133T-72		Q201	8-729-029-94	TRANSISTOR DTC143TSA-TP	
D701	8-719-024-99	DIODE 11ES2-NTA2B		Q202	8-729-142-25	TRANSISTOR 2SD1020TP-HFE	
D702	8-719-024-99	DIODE 11ES2-NTA2B		Q204	8-729-030-02	TRANSISTOR DTC144ESA-TP	
D703	8-719-024-99	DIODE 11ES2-NTA2B		Q301	8-729-119-76	TRANSISTOR 2SA1115TP-EF	
D704	8-719-024-99	DIODE 11ES2-NTA2B		Q302	8-729-030-02	TRANSISTOR DTC144ESA-TP	
D705	8-719-024-99	DIODE 11ES2-NTA2B		Q303	8-729-140-04	TRANSISTOR 2SB1116A-TP-LK	
D706	8-719-024-99	DIODE 11ES2-NTA2B		Q304	8-729-801-84	TRANSISTOR 2SB1013-TP-34	
D707	8-719-024-99	DIODE 11ES2-NTA2B		Q305	8-729-801-93	TRANSISTOR 2SD1387-34-TP	
D708	8-719-911-19	DIODE 1SS133T-72		Q306	8-729-801-84	TRANSISTOR 2SB1013-TP-34	
D709	8-719-933-33	DIODE HZS6A1LTA		Q307	8-729-801-93	TRANSISTOR 2SD1387-34-TP	
D710	8-719-933-33	DIODE HZS6A1LTA		Q308	8-729-030-02	TRANSISTOR DTC144ESA-TP	
D711	8-719-933-54	DIODE HZS9A2LTA		Q309	8-729-030-02	TRANSISTOR DTC144ESA-TP	
D712	8-719-933-35	DIODE HZS6A3LTA		Q310	8-729-029-94	TRANSISTOR DTC143TSA-TP	
D713	8-719-911-19	DIODE 1SS133T-72		Q311	8-729-620-05	TRANSISTOR 2SC2603TP-EF (KE240)	
D714	8-719-911-19	DIODE 1SS133T-72		Q331	8-729-119-76	TRANSISTOR 2SA1115TP-EF (RE340)	
D715	8-719-911-19	DIODE 1SS133T-72		Q332	8-729-194-57	TRANSISTOR 2SC945TP-QP	
D716	8-719-985-95	DIODE HZS7A2LTA		Q333	8-729-194-57	TRANSISTOR 2SC945TP-QP	
D717	8-719-985-41	DIODE HZS2CLL-TA		Q341	8-729-119-76	TRANSISTOR 2SA1115TP-EF	
D901	8-719-313-43	LED SEL6210S-TH10 (AUTO REC LEVEL)		Q351	8-729-620-05	TRANSISTOR 2SC2603TP-EF (RE340)	
D902	8-719-313-43	LED SEL6210S-TH10 (SYNCHRO)		Q352	8-729-620-05	TRANSISTOR 2SC2603TP-EF (RE340)	
D931	8-719-911-19	DIODE 1SS133T-72		Q601	8-729-620-05	TRANSISTOR 2SC2603TP-EF	
				Q701	8-729-141-83	TRANSISTOR 2SB1375	
		< FLUORESCENT INDICATOR TUBE >					
FLT901	1-517-173-11	INDICATOR TUBE, FLUORESCENT					
		< IC >					
IC301	8-752-075-27	IC CXA1878Q		Q702	8-729-209-15	TRANSISTOR 2SD2012	
IC302	8-759-634-50	IC M5218AL		Q703	8-729-141-83	TRANSISTOR 2SB1375	
IC303	8-759-710-59	IC NJM4580D-D		Q704	8-729-119-78	TRANSISTOR 2SC2785TP-HFE	
IC304	8-759-000-48	IC MC14052BCP		Q707	8-729-119-76	TRANSISTOR 2SA1175TP-HFE	
IC305	8-759-916-14	IC MC74HC04AN (RE340)		Q708	8-729-140-04	TRANSISTOR 2SB1116A-TP-LK	
IC306	8-759-634-50	IC M5218AL				< RESISTOR >	
IC331	8-759-106-56	IC uPC1297CA (RE340)		R101	1-249-429-11	CARBON 10K 5% 1/4W	
IC701	8-759-634-51	IC NJM4558D		R102	1-247-887-00	CARBON 220K 5% 1/4W	
IC801	8-752-913-09	IC CXP82220-053Q		R103	1-249-441-11	CARBON 100K 5% 1/4W	
IC802	8-759-165-82	IC PST600E-T		R104	1-249-420-11	CARBON 1.8K 5% 1/4W	
				R105	1-247-843-11	CARBON 3.3K 5% 1/4W	
IC901	8-759-459-86	IC NJL64H400A (■)		R106	1-247-842-11	CARBON 3K 5% 1/4W	
IC902	8-759-547-59	IC M35500BGP		R107	1-249-417-11	CARBON 1K 5% 1/4W	
				R108	1-249-427-11	CARBON 6.8K 5% 1/4W	
		< JACK >		R109	1-249-429-11	CARBON 10K 5% 1/4W	
J301	1-770-614-11	JACK, PIN 4P (IN/OUT)		R110	1-249-425-11	CARBON 4.7K 5% 1/4W	
J502	1-568-519-41	JACK, LARGE TYPE (PHONES)				(RE340)	

MAIN

DISPLAY, HP, KEY, POWER SW, TRANS

Ref. No.	Part No.	Description			Remark	Ref. No.	Part No.	Description			Remark
R110	1-249-426-11	CARBON	5.6K	5%	1/4W (KE240)	R242	1-247-883-00	CARBON	150K	5%	1/4W (RE340)
R111	1-249-417-11	CARBON	1K	5%	1/4W	△R243	1-219-153-11	FUSIBLE	10	5%	1/4W F (RE340)
R115	1-249-433-11	CARBON	22K	5%	1/4W	R244	1-249-435-11	CARBON	33K	5%	1/4W (RE340)
R116	1-247-843-11	CARBON	3.3K	5%	1/4W	R245	1-249-431-11	CARBON	15K	5%	1/4W (RE340)
R117	1-249-429-11	CARBON	10K	5%	1/4W	R251	1-249-437-11	CARBON	47K	5%	1/4W
R118	1-249-409-11	CARBON	220	5%	1/4W	R301	1-215-455-00	METAL	27K	1%	1/4W
R119	1-249-417-11	CARBON	1K	5%	1/4W	R302	1-215-452-00	METAL	20K	1%	1/4W
R120	1-249-439-11	CARBON	68K	5%	1/4W	R303	1-247-876-11	CARBON	75K	5%	1/4W
R121	1-247-881-00	CARBON	120K	5%	1/4W	R304	1-249-417-11	CARBON	1K	5%	1/4W
R122	1-247-807-31	CARBON	100	5%	1/4W	R305	1-247-903-00	CARBON	1M	5%	1/4W
R123	1-247-882-11	CARBON	130K	5%	1/4W	R306	1-249-422-11	CARBON	2.7K	5%	1/4W
R124	1-247-850-11	CARBON	6.2K	5%	1/4W	R307	1-249-417-11	CARBON	1K	5%	1/4W
R126	1-249-421-11	CARBON	2.2K	5%	1/4W	R308	1-249-429-11	CARBON	10K	5%	1/4W
R127	1-249-430-11	CARBON	12K	5%	1/4W	R309	1-249-429-11	CARBON	10K	5%	1/4W
R128	1-249-417-11	CARBON	1K	5%	1/4W	R310	1-249-413-11	CARBON	470	5%	1/4W
R129	1-249-421-11	CARBON	2.2K	5%	1/4W	R311	1-249-417-11	CARBON	1K	5%	1/4W
R130	1-249-434-11	CARBON	27K	5%	1/4W	R312	1-249-429-11	CARBON	10K	5%	1/4W
R141	1-249-430-11	CARBON	12K	5%	1/4W	R313	1-249-431-11	CARBON	15K	5%	1/4W
R142	1-247-883-00	CARBON	150K	5%	1/4W (RE340)	R314	1-249-425-11	CARBON	4.7K	5%	1/4W
△R143	1-219-153-11	FUSIBLE	10	5%	1/4W F (RE340)	R315	1-249-425-11	CARBON	4.7K	5%	1/4W
R144	1-249-435-11	CARBON	33K	5%	1/4W (RE340)	R316	1-249-435-11	CARBON	33K	5%	1/4W
R145	1-249-431-11	CARBON	15K	5%	1/4W (RE340)	R317	1-247-862-11	CARBON	20K	5%	1/4W
R151	1-249-437-11	CARBON	47K	5%	1/4W	R318	1-249-437-11	CARBON	47K	5%	1/4W
R201	1-249-429-11	CARBON	10K	5%	1/4W	R319	1-249-414-11	CARBON	560	5%	1/4W
R202	1-247-887-00	CARBON	220K	5%	1/4W	R320	1-249-419-11	CARBON	1.5K	5%	1/4W
R203	1-249-441-11	CARBON	100K	5%	1/4W	R321	1-249-437-11	CARBON	47K	5%	1/4W
R204	1-249-420-11	CARBON	1.8K	5%	1/4W	R322	1-249-437-11	CARBON	47K	5%	1/4W
R205	1-247-843-11	CARBON	3.3K	5%	1/4W	R323	1-249-419-11	CARBON	1.5K	5%	1/4W
R206	1-247-842-11	CARBON	3K	5%	1/4W	R324	1-249-419-11	CARBON	1.5K	5%	1/4W
R207	1-249-417-11	CARBON	1K	5%	1/4W	R325	1-249-437-11	CARBON	47K	5%	1/4W
R208	1-249-427-11	CARBON	6.8K	5%	1/4W	R326	1-249-437-11	CARBON	47K	5%	1/4W
R209	1-249-429-11	CARBON	10K	5%	1/4W	R327	1-249-429-11	CARBON	10K	5%	1/4W
R210	1-249-425-11	CARBON	4.7K	5%	1/4W (RE340)	R328	1-249-413-11	CARBON	470	5%	1/4W
R210	1-249-426-11	CARBON	5.6K	5%	1/4W (KE240)	R329	1-249-437-11	CARBON	47K	5%	1/4W
R211	1-249-417-11	CARBON	1K	5%	1/4W	R330	1-249-401-11	CARBON	47	5%	1/4W
R215	1-249-433-11	CARBON	22K	5%	1/4W	R331	1-249-417-11	CARBON	1K	5%	1/4W
R216	1-247-843-11	CARBON	3.3K	5%	1/4W	R332	1-249-429-11	CARBON	10K	5%	1/4W
R217	1-249-429-11	CARBON	10K	5%	1/4W	R333	1-249-390-11	CARBON	5.6	5%	1/4W (RE340)
R218	1-249-409-11	CARBON	220	5%	1/4W	R333	1-249-387-11	CARBON	3.3	5%	1/4W (KE240)
R219	1-249-417-11	CARBON	1K	5%	1/4W	R334	1-249-390-11	CARBON	5.6	5%	1/4W (RE340)
R220	1-249-439-11	CARBON	68K	5%	1/4W	R334	1-249-387-11	CARBON	3.3	5%	1/4W (KE240)
R221	1-247-881-00	CARBON	120K	5%	1/4W	R335	1-249-440-11	CARBON	82K	5%	1/4W (RE340)
R222	1-247-807-31	CARBON	100	5%	1/4W	R335	1-249-432-11	CARBON	18K	5%	1/4W (KE240)
R223	1-247-882-11	CARBON	130K	5%	1/4W	R336	1-249-440-11	CARBON	82K	5%	1/4W (RE340)
R224	1-247-850-11	CARBON	6.2K	5%	1/4W	R336	1-249-432-11	CARBON	18K	5%	1/4W (KE240)
R226	1-249-421-11	CARBON	2.2K	5%	1/4W	R337	1-249-429-11	CARBON	10K	5%	1/4W
R227	1-249-430-11	CARBON	12K	5%	1/4W	R338	1-249-429-11	CARBON	10K	5%	1/4W
R228	1-249-417-11	CARBON	1K	5%	1/4W						
R229	1-249-421-11	CARBON	2.2K	5%	1/4W						
R230	1-249-434-11	CARBON	27K	5%	1/4W						
R241	1-249-430-11	CARBON	12K	5%	1/4W						

The components identified by mark △ or dotted line with mark △ are critical for safety.
Replace only with part number specified.

MAIN
DISPLAY, HP, KEY, POWER SW, TRANS

Ref. No.	Part No.	Description	Remark	Ref. No.	Part No.	Description	Remark
R339	1-249-429-11	CARBON	10K 5% 1/4W (KE240)	R377	1-249-434-11	CARBON	27K 5% 1/4W (RE340)
R340	1-249-385-11	CARBON	2.2 5% 1/6W (KE240)	R601	1-249-429-11	CARBON	10K 5% 1/4W
R341	1-249-429-11	CARBON	10K 5% 1/4W	R602	1-249-417-11	CARBON	1K 5% 1/4W
R342	1-249-425-11	CARBON	4.7K 5% 1/4W	R603	1-249-425-11	CARBON	4.7K 5% 1/4W
R343	1-249-430-11	CARBON	12K 5% 1/4W (KE240)	R604	1-249-429-11	CARBON	10K 5% 1/4W
R344	1-247-834-11	CARBON	1.3K 5% 1/4W (KE240)	R605	1-249-393-11	CARBON	10 5% 1/4W
R345	1-247-850-11	CARBON	6.2K 5% 1/4W (KE240)	R701	1-249-414-11	CARBON	560 5% 1/4W
R351	1-249-426-11	CARBON	5.6K 5% 1/4W (RE340)	R702	1-249-409-11	CARBON	220 5% 1/4W
R352	1-249-433-11	CARBON	22K 5% 1/4W (RE340)	R703	1-249-422-11	CARBON	2.7K 5% 1/4W
R353	1-249-436-11	CARBON	39K 5% 1/4W (RE340)	R704	1-249-425-11	CARBON	4.7K 5% 1/4W
R354	1-249-425-11	CARBON	4.7K 5% 1/4W (RE340)	R705	1-249-427-11	CARBON	6.8K 5% 1/4W
R355	1-249-425-11	CARBON	4.7K 5% 1/4W (RE340)	R706	1-249-419-11	CARBON	1.5K 5% 1/4W
R356	1-249-441-11	CARBON	100K 5% 1/4W (RE340)	R707	1-249-429-11	CARBON	10K 5% 1/4W
R357	1-249-441-11	CARBON	100K 5% 1/4W (RE340)	R708	1-247-836-11	CARBON	1.6K 5% 1/4W
R358	1-249-424-11	CARBON	3.9K 5% 1/4W (RE340)	R709	1-249-425-11	CARBON	4.7K 5% 1/4W
R359	1-249-437-11	CARBON	47K 5% 1/4W	R710	1-249-417-11	CARBON	1K 5% 1/4W
R360	1-249-437-11	CARBON	47K 5% 1/4W	R711	1-249-427-11	CARBON	6.8K 5% 1/4W
R361	1-249-437-11	CARBON	47K 5% 1/4W	R712	1-249-427-11	CARBON	6.8K 5% 1/4W
R362	1-249-428-11	CARBON	8.2K 5% 1/4W (RE340)	R714	1-249-421-11	CARBON	2.2K 5% 1/4W
R363	1-249-433-11	CARBON	22K 5% 1/4W (RE340)	R715	1-249-421-11	CARBON	2.2K 5% 1/4W
R364	1-247-832-11	CARBON	1.1K 5% 1/4W (RE340)	R716	1-249-429-11	CARBON	10K 5% 1/4W
R365	1-249-421-11	CARBON	2.2K 5% 1/4W (RE340)	R717	1-249-429-11	CARBON	10K 5% 1/4W
R366	1-247-852-11	CARBON	7.5K 5% 1/4W (RE340)	R718	1-247-870-11	CARBON	43K 5% 1/4W
R367	1-247-866-11	CARBON	30K 5% 1/4W (RE340)	R719	1-249-437-11	CARBON	47K 5% 1/4W
R368	1-249-431-11	CARBON	15K 5% 1/4W (RE340)	R801	1-249-429-11	CARBON	10K 5% 1/4W (RE340)
R369	1-247-874-11	CARBON	62K 5% 1/4W (RE340)	R802	1-249-417-11	CARBON	1K 5% 1/4W
R370	1-249-429-11	CARBON	10K 5% 1/4W (RE340)	R803	1-249-430-11	CARBON	12K 5% 1/4W (RE340)
R371	1-249-429-11	CARBON	10K 5% 1/4W (RE340)	R804	1-247-852-11	CARBON	7.5K 5% 1/4W (RE340)
R372	1-249-429-11	CARBON	10K 5% 1/4W (RE340)	R805	1-249-426-11	CARBON	5.6K 5% 1/4W (RE340)
R373	1-249-429-11	CARBON	10K 5% 1/4W (RE340)	R806	1-249-422-11	CARBON	2.7K 5% 1/4W (RE340)
R374	1-249-434-11	CARBON	27K 5% 1/4W (RE340)	R807	1-249-428-11	CARBON	8.2K 5% 1/4W (RE340)
R375	1-249-434-11	CARBON	27K 5% 1/4W (RE340)	R808	1-249-428-11	CARBON	8.2K 5% 1/4W (RE340)
R376	1-249-434-11	CARBON	27K 5% 1/4W (RE340)	R809	1-249-425-11	CARBON	4.7K 5% 1/4W (RE340)
				R810	1-249-425-11	CARBON	4.7K 5% 1/4W (RE340)
				R811	1-249-429-11	CARBON	10K 5% 1/4W
				R812	1-247-807-31	CARBON	100 5% 1/4W
				R813	1-249-441-11	CARBON	100K 5% 1/4W
				R814	1-247-807-31	CARBON	100 5% 1/4W
				R815	1-249-417-11	CARBON	1K 5% 1/4W
				R816	1-249-441-11	CARBON	100K 5% 1/4W
				R817	1-249-429-11	CARBON	10K 5% 1/4W
				R818	1-249-429-11	CARBON	10K 5% 1/4W
				R819	1-249-433-11	CARBON	22K 5% 1/4W
				R820	1-249-429-11	CARBON	10K 5% 1/4W
				R821	1-249-429-11	CARBON	10K 5% 1/4W (KE240)
				R901	1-249-413-11	CARBON	470 5% 1/4W
				R902	1-249-413-11	CARBON	470 5% 1/4W
				R911	1-249-418-11	CARBON	1.2K 5% 1/4W
				R912	1-249-420-11	CARBON	1.8K 5% 1/4W

MAIN

DISPLAY, HP, KEY, POWER SW, TRANS

Ref. No.	Part No.	Description	Remark
R913	1-249-422-11	CARBON 2.7K 5%	1/4W
R914	1-249-424-11	CARBON 3.9K 5%	1/4W
R915	1-249-427-11	CARBON 6.8K 5%	1/4W
R916	1-249-418-11	CARBON 1.2K 5%	1/4W
R917	1-249-420-11	CARBON 1.8K 5%	1/4W
R918	1-249-422-11	CARBON 2.7K 5%	1/4W
R919	1-249-424-11	CARBON 3.9K 5%	1/4W
R921	1-249-418-11	CARBON 1.2K 5%	1/4W
R922	1-249-420-11	CARBON 1.8K 5%	1/4W
R923	1-249-422-11	CARBON 2.7K 5%	1/4W
R924	1-249-424-11	CARBON 3.9K 5%	1/4W
R925	1-249-427-11	CARBON 6.8K 5%	1/4W (RE340)
R931	1-249-418-11	CARBON 1.2K 5%	1/4W
R932	1-249-420-11	CARBON 1.8K 5%	1/4W (RE340)
R933	1-249-422-11	CARBON 2.7K 5%	1/4W (RE340)
R934	1-249-437-11	CARBON 47K 5%	1/4W
R935	1-249-417-11	CARBON 1K 5%	1/4W
R936	1-249-417-11	CARBON 1K 5%	1/4W
R937	1-249-417-11	CARBON 1K 5%	1/4W
R938	1-249-417-11	CARBON 1K 5%	1/4W
R939	1-249-417-11	CARBON 1K 5%	1/4W
R940	1-249-429-11	CARBON 10K 5%	1/4W
R941	1-247-807-31	CARBON 100 5%	1/4W
R942	1-247-807-31	CARBON 100 5%	1/4W
< VARIABLE RESISTOR >			
RV101	1-241-765-11	RES, ADJ, CARBON 22K	
RV121	1-241-764-11	RES, ADJ, CARBON 10K	
RV141	1-241-765-11	RES, ADJ, CARBON 22K (RE340)	
RV142	1-241-767-21	RES, ADJ, CARBON 100K (KE240)	
RV201	1-241-765-11	RES, ADJ, CARBON 22K	
RV221	1-241-764-11	RES, ADJ, CARBON 10K	
RV241	1-241-765-11	RES, ADJ, CARBON 22K (RE340)	
RV242	1-241-767-21	RES, ADJ, CARBON 100K (KE240)	
RV301	1-241-765-11	RES, ADJ, CARBON 22K	
RV901	1-225-707-11	RES, VAR, CARBON 20K (REC LEVEL)	
RV902	1-225-619-11	RES, VAR, CARBON 10K (BALANCE)	
< RELAY >			
RY341	1-755-061-11	RELAY	
< SWITCH >			
S911	1-771-349-21	SWITCH, KEYBOARD (◀◀)	
S912	1-771-349-21	SWITCH, KEYBOARD (▶▶)	
S913	1-771-349-21	SWITCH, KEYBOARD (REC ●)	
S914	1-771-349-21	SWITCH, KEYBOARD (FADER)	
S915	1-771-349-21	SWITCH, KEYBOARD (ARL)	
S916	1-771-349-21	SWITCH, KEYBOARD (SYNCHRO)	
S917	1-762-641-11	SWITCH, ROTARY (DOLBY NR)	
S921	1-771-349-21	SWITCH, KEYBOARD (■)	
S922	1-771-349-21	SWITCH, KEYBOARD (PAUSE ■■)	
S923	1-771-349-21	SWITCH, KEYBOARD (AMS ▶▶, ▷) (RE340)	
S924	1-771-349-21	SWITCH, KEYBOARD (◀◀ AMS ▶▶, ▷) (KE240)	

Ref. No.	Part No.	Description	Remark
S925	1-771-349-21	SWITCH, KEYBOARD (◀◀ AMS, ◀) (RE340)	
S926	1-771-349-21	SWITCH, KEYBOARD (REC MUTING ◯)	
S927	1-771-349-21	SWITCH, KEYBOARD (AUTO CAL) (RE340)	
△S930	1-762-581-11	SWITCH, AC POWER PUSH (1 KEY) (POWER)	
S931	1-771-349-21	SWITCH, KEYBOARD (MEMORY)	
S932	1-771-349-21	SWITCH, KEYBOARD (RESET)	
S933	1-762-609-11	SWITCH, SLIDE (DIRECTION MODE) (RE340: AEP (BLACK), SP, AUS)	
S933	1-762-609-21	SWITCH, SLIDE (DIRECTION MODE) (RE340: AEP (SILVER))	
< TRANSFORMER >			
T101	1-433-381-11	TRANSFORMER, BIAS OSCILLATOR (RE340)	
T201	1-433-381-11	TRANSFORMER, BIAS OSCILLATOR (RE340)	
T301	1-429-222-11	TRANSFORMER, BIAS OSCILLATION (RE340)	
T301	1-435-356-11	TRANSFORMER, BIAS OSCILLATION (KE240)	
△T701	1-426-651-21	TRANSFORMER, POWER (AEP, UK, AUS)	
△T701	1-426-652-21	TRANSFORMER, POWER (SP)	
< CONNECTOR >			
TP301	1-766-276-11	PIN, CONNECTOR (PC BOARD) 3P (RE340)	
< VIBRATOR >			
X801	1-579-175-11	VIBRATOR, CERAMIC (10MHz)	

MISCELLANEOUS			

△5	1-751-535-11	CORD, POWER (UK)	
△5	1-777-107-11	CORD, POWER (AEP, SP)	
△5	1-777-218-11	CORD, POWER (AUS)	
60	1-769-948-11	WIRE (FLAT TYPE) (11 CORE)	
64	1-769-976-11	WIRE (FLAT TYPE) (13 CORE)	
HRPE1	A-2004-646-D	DECK ASSY, HEAD (RECORD/PLAYBACK/ERASE) (RE340)	
HRPE1	A-2004-774-A	BASE ASSY, HEAD (RECORD/PLAYBACK/ERASE) (KE240)	
M1002	A-2004-644-A	MOTOR ASSY, CAPSTAN	
△S701	1-570-046-21	SWITCH, VOLTAGE CHANGE (VOLTAGE SELECTOR) (RE340: SP)	
△T701	1-426-651-21	TRANSFORMER, POWER (AEP, UK, AUS)	
△T701	1-426-652-21	TRANSFORMER, POWER (SP)	

The components identified by mark △ or dotted line with mark △ are critical for safety. Replace only with part number specified.

<u>Ref. No.</u>	<u>Part No.</u>	<u>Description</u>	<u>Remark</u>
		***** HARDWARE LIST *****	
#1	7-685-646-79	SCREW +BVTP 3X8 TYPE2 N-S	
#2	7-685-871-01	SCREW +BVTT 3X6 (S)	
#3	7-685-872-09	SCREW +BVTT 3X8 (S)	
#4	7-685-902-21	SCREW +PTPWH 2.6X8 (TYPE2)	
#5	7-685-851-09	SCREW +BVTT 2X4 (S)	
#6	7-628-254-15	SCREW +PS 2.6X6	
#7	7-623-505-01	LUG, 2	
#9	7-685-851-04	SCREW +BVTT 2X4 (S)	
#10	7-685-852-04	SCREW +BVTT 2X5 (S)	

ACCESSORIES & PACKING MATERIALS

1-776-263-51	CORD, CONNECTION	
3-866-671-11	MANUAL, INSTRUCTION (CONTROL A1II) (ENGLISH) (UK, AUS)	
3-866-671-21	MANUAL, INSTRUCTION (CONTROL A1II) (ENGLISH, FRENCH, GERMAN, SPANISH, DUTCH, PORTUGUESE, SWEDISH, ITALIAN, CHINESE) (AEP, SP)	
4-227-170-11	MANUAL, INSTRUCTION (ENGLISH, FRENCH, SPANISH)	
4-227-170-21	MANUAL, INSTRUCTION (GERMAN, DUTCH, SWEDISH, ITALIAN, PORTUGUESE) (AEP)	
4-227-170-31	MANUAL, INSTRUCTION (CHINESE) (SP)	

