

TC-RX390

SERVICE MANUAL

US Model
Canadian Model
AEP Model



Model Name Using Similar Mechanism	TC-RX370
Tape Transport Mechanism Type	TCM-190RB12CJ

SPECIFICATIONS

Recording system 4-track 2-channel stereo
Fast winding time Approx. 90 sec. (with Sony C-60 cassette)
Bias AC bias
Heads Erasing head × 1 (F&F head)
Playback/Recording head × 1 (SD head)
Motors Capstan motor × 1 (DC servo motor)
Reel motor × 1 (DC motor)

Signal-to-noise ratio (at peak level)

Cassette (Dolby NR OFF)	Type IV (Sony Metal-S/Select)	Type II (Sony UX-S)	Type I (Sony HF-S)
	58 dB	57 dB	55 dB

Measured at peak level weighted without NR. The S/N is improved by about 15 dB at 500 Hz and by about 20 dB about 1 kHz with Dolby-C NR on, and by 5 dB at 1 kHz and by 10 dB about 5 kHz with Dolby-B NR on.

Harmonic distortion 0.4% (with Sony TYPE I, 160 nWb/m,
315 Hz, 3rd H.D.)
1.8% (with Sony TYPE IV, 250 nWb/m,
315 Hz, 3rd H.D.)

Frequency response (DOLBY NR OFF)

Type IV cassette (Sony Metal-S/Select)	30 - 15,000 Hz (±3 dB, IEC) 30 - 13,000 Hz [±3 dB (-4 dB recording)]
Type II cassette (Sony UX-S)	30 - 15,000 Hz (±3 dB, IEC)
Type I cassette (Sony HF-S)	30 - 14,000 Hz (±3 dB, IEC)

Wow and flutter ± 0.13% W.Peak (IEC)
0.07% W.RMS (NAB)
± 0.18% W.Peak (DIN)

Inputs

Line inputs (phono jacks)	Sensitivity	0.16 V
	Input impedance	47 k ohms

Outputs

Line outputs (phono jacks)	Rated output level	0.5 V at a load impedance of 47 k ohms
	Load impedance	Over 10 k ohms
Headphones (stereo phono jack)	Output level	1 mW at a load impedance of 32 ohms

General

Power requirements

US, Canadian Model : 120V AC, 60 Hz
AEP Model : 220-230V AC, (or 240V AC adjustable by
Sony personnel), 50/60 Hz

Power consumption 21 W
Dimensions

Approx. 430 × 123 × 300 mm (w/h/d)
(17 × 4⁷/₈ × 11⁷/₈ inches)
including projecting parts and controls
Approx. 3.8 kg (8 lbs 6 oz)

Weight

Supplied accessories

Audio connecting cords (2)

Design and specifications are subject to change without notice.

Note

This appliance conforms with EEC Directive 87/308/EEC regarding
interference suppression.

STEREO CASSETTE DECK
SONY®

TABLE OF CONTENTS

<i>Section</i>	<i>Title</i>	<i>Page</i>
specifications	1
Safety Check-out	3
1. GENERAL		
1-1. Identifying the Parts	4
2. DISASSEMBLY		
2-1. Front Panel	5
2-2. Mechanism Deck	5
2-3. Head	6
2-4. Fitting Base Block	6
2-5. Motor	6
3. BLOCK DIAGRAM	7
4. EXPLANATION OF IC TERMINALS	9
5. ADJUSTMENTS		
5-1. Mechanical Adjutments	11
5-2. Electrical Adjustments	11
6. DIAGRAMS		
6-1. Circuit Boards Location	14
6-2. Printed Wiring Boards	15
6-3. Schematic Diagram (SYSTEM CONTROL SECTION)	19
6-4. Schematic Diagram (AUDIO SECTION)	24
7. EXPLODED VIEWS		
7-1. Chassis Section	27
7-2. Front Panel Section	28
7-3. Mechanism Section1	29
7-4. Mechanism Section2	30
8. ELECTRICAL PARTS LIST	31

MODEL IDENTIFICATION
(Specification Label)

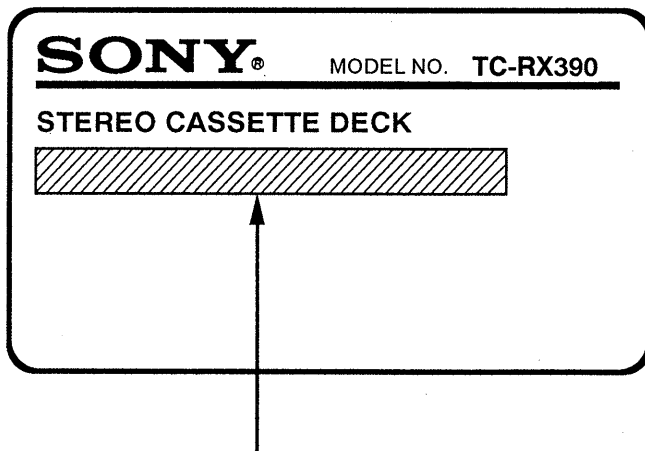

US, Canadian model : AC 120V 60Hz 21W
AEP model : AC 220-230V~50 /60Hz 21W

SAFETY CHECK-OUT

After correcting the original service problem, perform the following safety check before releasing the set to the customer:

Check the antenna terminals, metal trim, "metallized" knobs, screws, and all other exposed metal parts for AC leakage. Check leakage as described below.

LEAKAGE TEST

The AC leakage from any exposed metal part to earth ground and from all exposed metal parts to any exposed metal part having a return to chassis, must not exceed 0.5 mA (500 microamperes). Leakage current can be measured by any one of three methods.

1. A commercial leakage tester, such as the Simpson 229 or RCA WT-540A. Follow the manufacturers' instructions to use these instruments.
2. A battery-operated AC milliammeter. The Data Precision 245 digital multimeter is suitable for this job.

3. Measuring the voltage drop across a resistor by means of a VOM or battery-operated AC voltmeter. The "limit" indication is 0.75 V, so analog meters must have an accurate low-voltage scale. The Simpson 250 and Sanwa SH-63Trd are examples of a passive VOM that is suitable. Nearly all battery operated digital multimeters that have a 2V AC range are suitable. (See Fig. A)

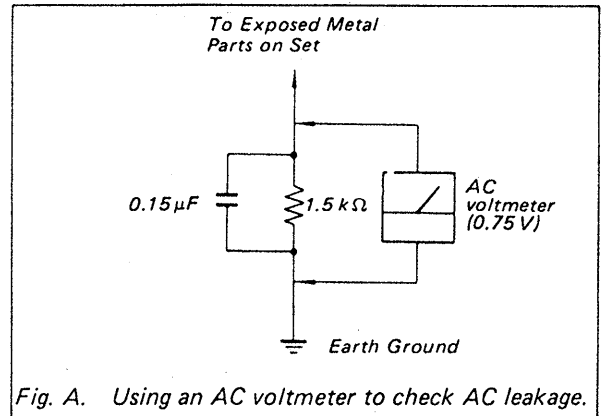

Fig. A. Using an AC voltmeter to check AC leakage.

SAFETY-RELATED COMPONENT WARNING!!

COMPONENTS IDENTIFIED BY MARK \triangle OR DOTTED LINE WITH MARK \triangle ON THE SCHEMATIC DIAGRAMS AND IN THE PARTS LIST ARE CRITICAL TO SAFE OPERATION. REPLACE THESE COMPONENTS WITH SONY PARTS WHOSE PART NUMBERS APPEAR AS SHOWN IN THIS MANUAL OR IN SUPPLEMENTS PUBLISHED BY SONY.

ATTENTION AU COMPOSANT AYANT RAPPORT À LA SÉCURITÉ!

LES COMPOSANTS IDENTIFIÉS PAR UNE MARQUE \triangle SUR LES DIAGRAMMES SCHÉMATIQUES ET LA LISTE DES PIÈCES SONT CRITIQUES POUR LA SÉCURITÉ DE FONCTIONNEMENT. NE REMPLACER CES COMPOSANTS QUE PAR DES PIÈCES SONY DONT LES NUMÉROS SONT DONNÉS DANS CE MANUEL OU DANS LES SUPPLÉMENTS PUBLIÉS PAR SONY.

SECTION 1 GENERAL

This section is extracted from instruction manual.

1-1. IDENTIFYING THE PARTS

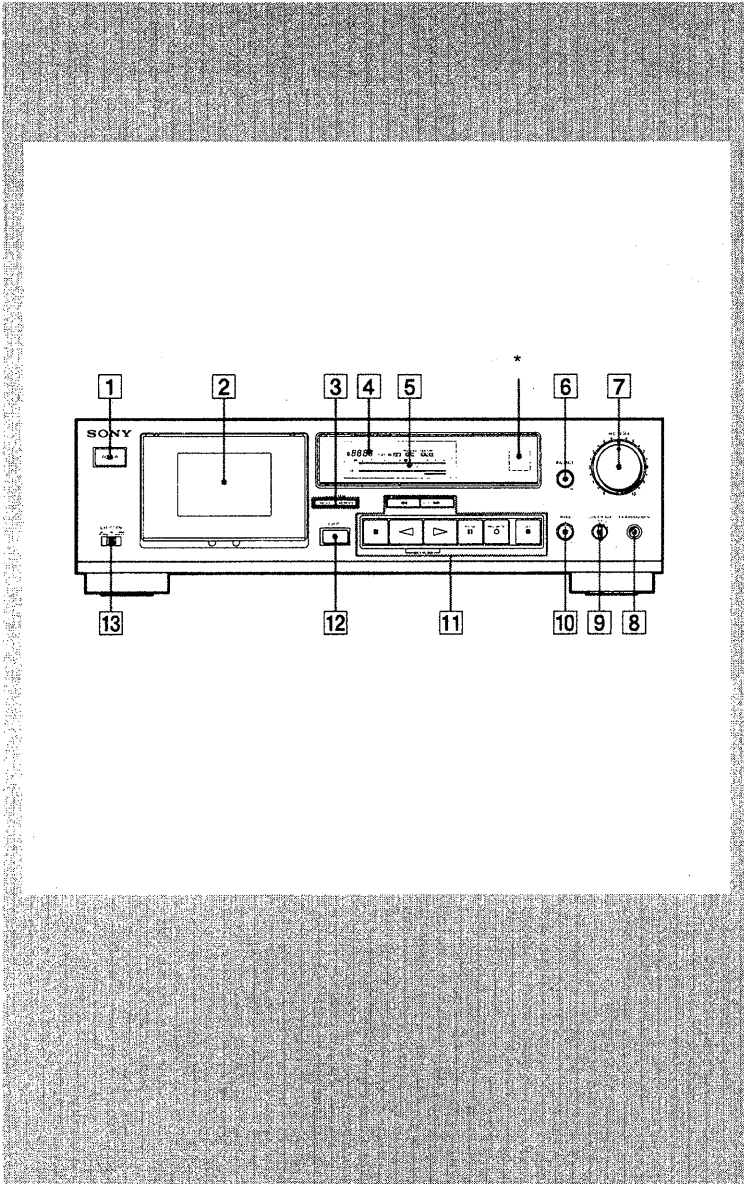



Front Panel

For details, refer to the page number indicated in parenthesis .

- 1 POWER switch
- 2 Cassette holder
- 3 Counter buttons
RESET button
MEMORY button
- 4 DIGITAL COUNTER
- 5 PEAK LEVEL METER
- 6 BALANCE control
- 7 REC (recording) LEVEL control
- 8 HEADPHONES jack (stereo phone jack)
- 9 DOLBY NR (noise reduction) switch
- 10 BIAS control
- 11 Tape operation buttons
◀◀ (leftward fast winding) button
▶▶ (rightward fast winding) button
■ (stop) button
◀ (reverse play) button
▶ (forward play) button
|| PAUSE button
○ REC MUTE (record muting) button
● REC (recording) button
- 12 ▲ (eject) button
- 13 DIRECTION mode switch

* Remote control sensor

You can remotely control this cassette deck with:

- A remote commander that came with a Sony amplifier or receiver if it has the  mark and cassette deck control capability.
- An optional Sony remote commander with the  mark and cassette deck control capability.

SECTION 2 DISASSEMBLY

Note : Follow the disassembly procedure in the numerical order given.

CASE
Unscrew the four case attachment screws M3 × 8 and remove the case.

2-1. FRONT PANEL

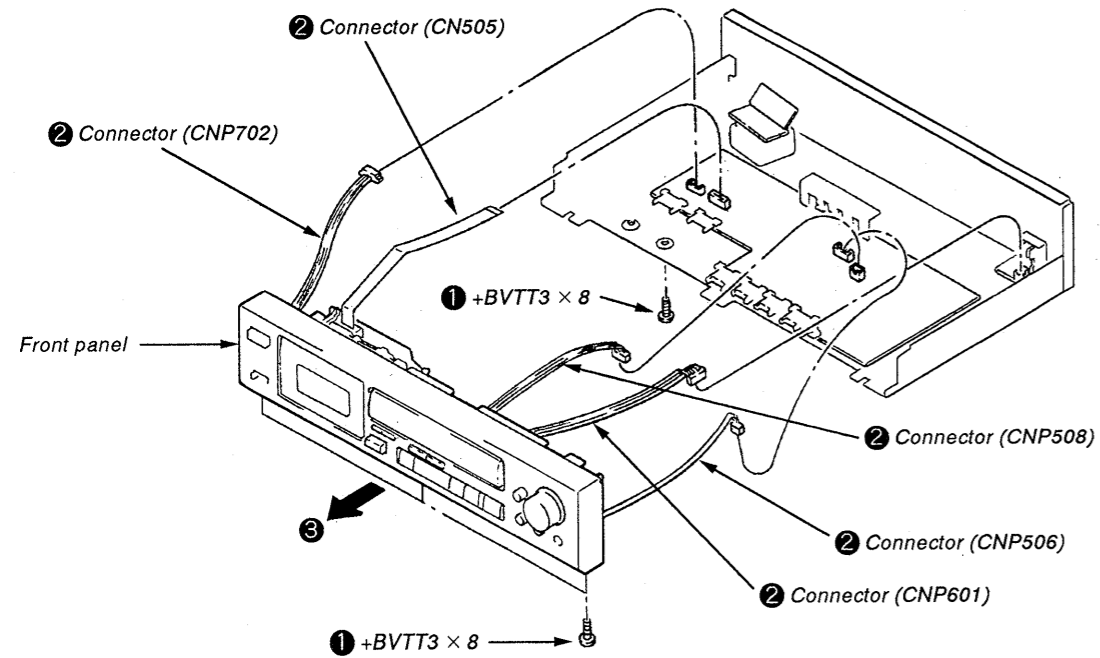

2-2. MECHANISM DECK

① Press the eject button.

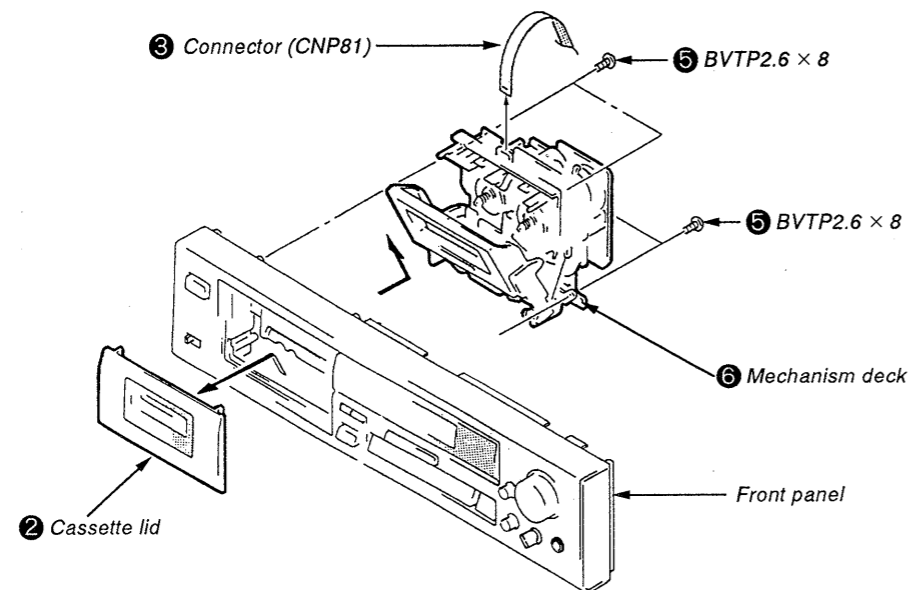

2-3. HEAD

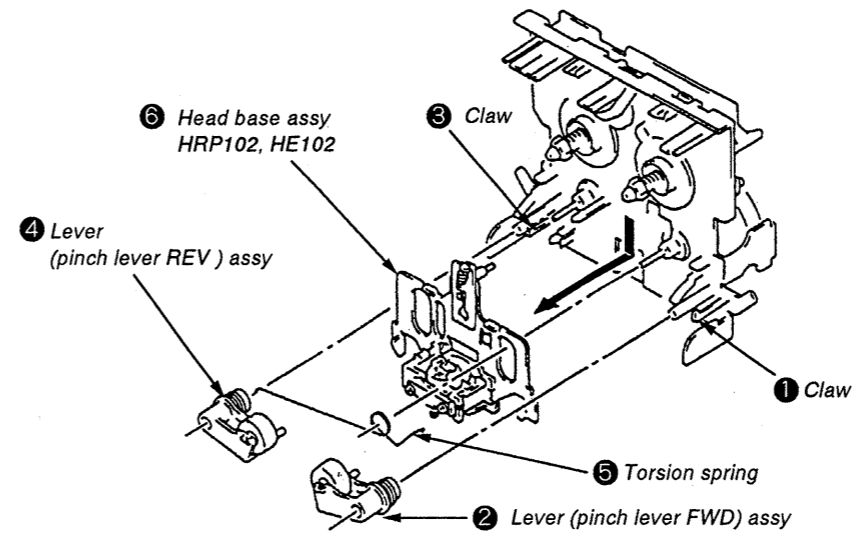

2-4. FITTING BASE BLOCK

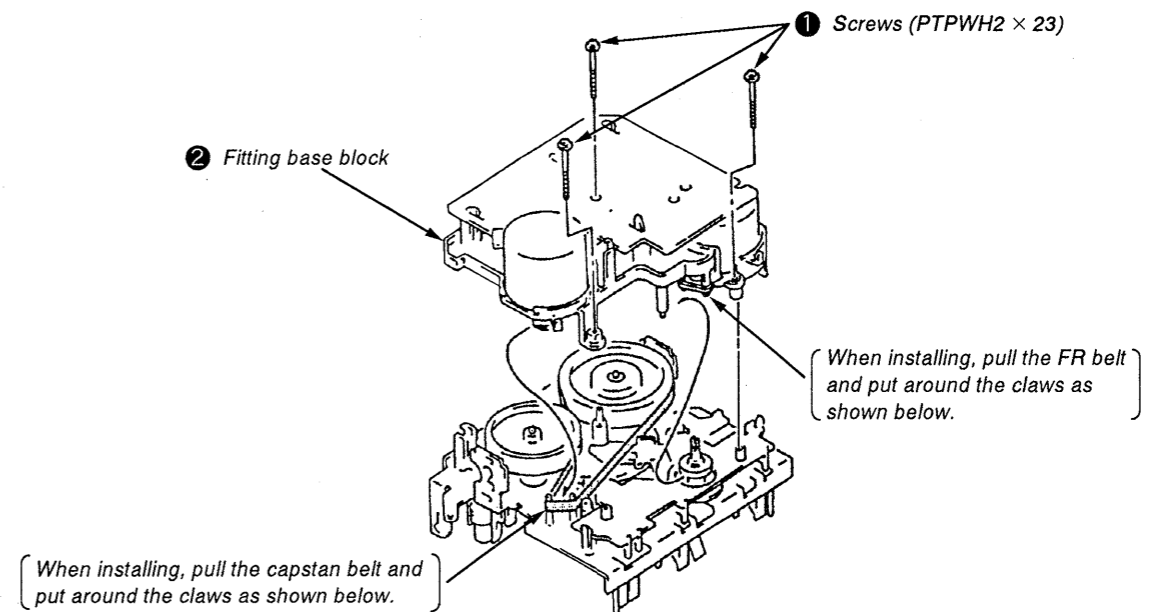

2-5. MOTOR

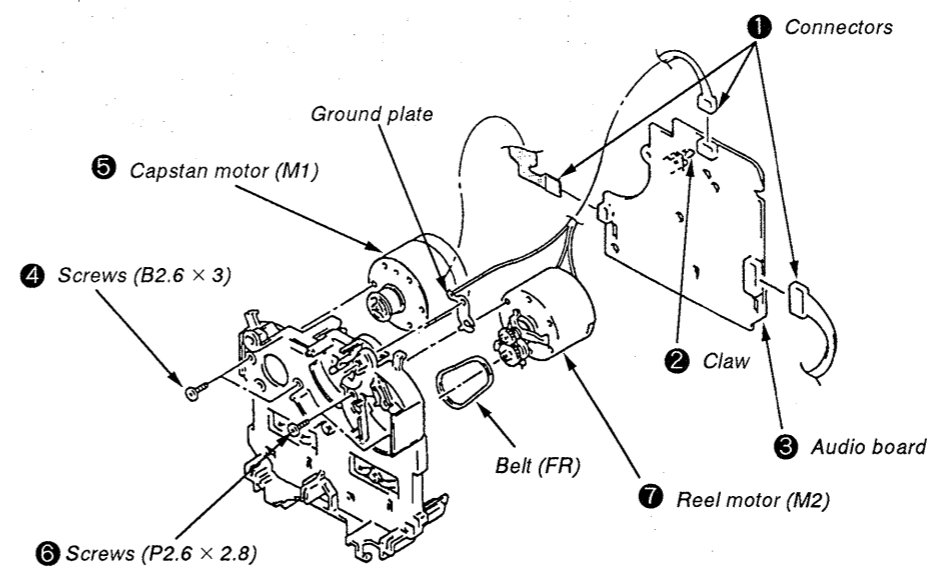

SECTION 3 BLOCK DIAGRAM

3-1. BLOCK DIAGRAM

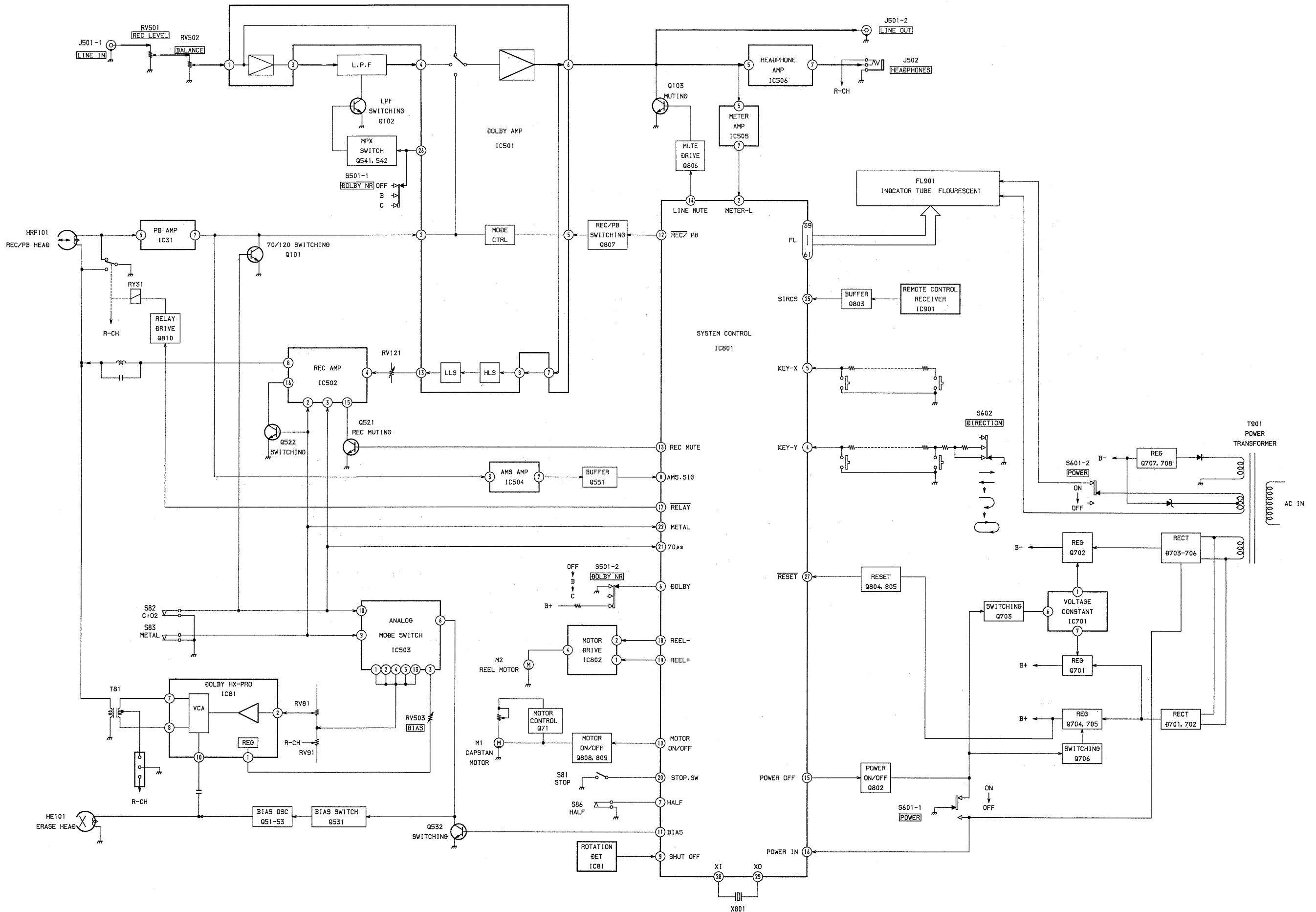

SECTION 4 EXPLANATION OF IC TERMINALS

IC801 M50940-395SP

Pin. No.	Terminal name	I/O	Terminal explanation																											
1	VREF	I	Reference voltage 5V																											
2	METER LCH	I	Meter level Lch																											
3	METER RCH	I	Meter level Rch																											
4	KEY Y	I	0V = stop, 0.8V = rew, 1.7V = ff, 2.6V = rec, 3.4V = ssw ⇐, 4.2V = ⇒, 5V = ⇐⇒																											
5	KEY X	I	0V = pause, 0.8V = fwd, 1.7V = rev, 2.6V = recm, 3.4V = reset, 4.2V = memory																											
6	DOLBY	I	OFF : 0 - 2.2V, B : 2.2 - 4.8V, C : 4.8V -																											
7	HALF	I	<table border="1" style="margin-left: auto; margin-right: auto;"> <thead> <tr> <th colspan="3">Switch status</th> <th rowspan="2">Input Voltage</th> </tr> <tr> <th>REC A</th> <th>REC B</th> <th>HALF</th> </tr> </thead> <tbody> <tr> <td>OFF</td> <td>OFF</td> <td>OFF</td> <td>5V</td> </tr> <tr> <td>ON</td> <td>OFF</td> <td>ON</td> <td>3.9V</td> </tr> <tr> <td>OFF</td> <td>OFF</td> <td>ON</td> <td>2.8V</td> </tr> <tr> <td>ON</td> <td>ON</td> <td>ON</td> <td>2V</td> </tr> <tr> <td>OFF</td> <td>ON</td> <td>ON</td> <td>1V</td> </tr> </tbody> </table>	Switch status			Input Voltage	REC A	REC B	HALF	OFF	OFF	OFF	5V	ON	OFF	ON	3.9V	OFF	OFF	ON	2.8V	ON	ON	ON	2V	OFF	ON	ON	1V
Switch status			Input Voltage																											
REC A	REC B	HALF																												
OFF	OFF	OFF	5V																											
ON	OFF	ON	3.9V																											
OFF	OFF	ON	2.8V																											
ON	ON	ON	2V																											
OFF	ON	ON	1V																											
8	AMS. SIG	I	Ams signal input 2.5V <MUSIC, 2.5V > not MUSIC																											
9	SHUT OFF	I	Supply pulse																											
10	MOTOR ON/OFF	O	Capstan motor. 5V = ON, 0V = OFF																											
11	BIAS	O	Bias osc 5V = ON																											
12	REC/PB	O	Recording/Playback selector for Dolby IC select 0V = Record, 5V = Playback																											
13	REC MUTE	O	Rec out mute. 5V = MUTE																											
14	LINE MUTE	O	Line out mute. 0V = MUTE																											
15	POWER OFF	O	0V = Power OFF, cut OFF = Power ON																											
16	POWER IN	- I	0V = Power OFF																											
17	RELAY	O	Relay selector. 5V = Record, 0V = Playback																											
18	REEL -	O	<table border="1" style="margin-left: auto; margin-right: auto;"> <thead> <tr> <th>trg</th> <th>ff</th> <th>play</th> <th>stop</th> </tr> </thead> <tbody> <tr> <td>0</td> <td>1</td> <td>open</td> <td>0</td> </tr> <tr> <td>1</td> <td>0</td> <td>0</td> <td>0</td> </tr> </tbody> </table> The open is high impedance.	trg	ff	play	stop	0	1	open	0	1	0	0	0															
trg	ff	play		stop																										
0	1	open	0																											
1	0	0	0																											
19	REEL +	O	Reel motor +																											
20	STOP. SW	I	Mecha stop mode SW. 5V = stop																											
21	70 μ S	I	Tape type 2. 5V = ON																											
22	METAL	I	Tape type 4. 5V = ON																											
23	NC	I	GND																											
24	NC	I	GND																											
25	SIRCS	I	Sircs signal in																											
26	CNVSS	I	GND																											
27	RESET	I	Reset. 0V = Reset																											
28	XIN	I	System clock in																											
29	XOUT	O	System clock out																											
30	CXIN	I	Not used																											
31	CXOUT	O	Not used																											
32	VSS	I	GND																											
33	NC	O	Not used																											
34	VERSION	I	5V = rev, 0V = oneway																											
35	TEST	I	Test mode selector. 5V = normal, 0V = test mode																											

Pin. No.	Terminal name	I/O	Terminal explanation
36	NC	I	GND
37	NC	I	GND
38	-21V	I	-21V
39 - 54	FL-a - p	O	FLT segment
55 - 61	FL-g5 - g1	O	FLT grid
62	NC	O	Not used
63	AVCC	I	Analog power supply in +5V
64	VCC	I	Power supply in +5V

IC502 CXA1579P

Pin. No.	Terminal name	I/O	Terminal explanation
1	SPEED	I	GND
2	METAL	I	Metal tape selector terminal "H" : METAL
3	70 μ S	I	CrO ₂ tape selector terminal "H" : CrO ₂
4	REC IN1	I	Recording equalizer amp input terminal
5	GND		GND
6	BOOST1	I	External capacitor for low-pass boost connecting terminal
7	VEE		-7.5V
8	REC OUT1	O	Recording equalizer amp output terminal
9	REC OUT2	O	Recording equalizer amp output terminal
10	VCC		+7.5V
11	BOOST2		External capacitor for low-pass boost connecting terminal
12	IREF	O	Standard current setting terminal of monolithic filter
13	REC IN2	I	Recording equalizer amp input terminal
14	REC CAL	I	Recording calibration terminal "H" : Recording level gain down
15	REC MUTE	I	Recording Mute ON/OFF selector terminal "H" : Mute OFF "L" : Mute ON
16	GP CAL	I	High-pass calibration terminal "H" : High-pass level gain down "L" : High-pass level gain up

SECTION 5 ADJUSTMENTS

5-1. MECHANICAL ADJUSTMENTS

PRECAUTION

- Clean the following parts with a denatured alcohol-moistened swab:

record/playback/erase head	pinch roller
rubber belts	capstan
idlers	
- Demagnetize the record/playback head with a head demagnetizer. (Head demagnetizer do not approach for the erase head.)
- Do not use a magnetized screwdriver for the adjustment.
- After the adjustments, apply suitable locking compound to the parts adjusted.
- The adjustments should be performed with the rated power supply voltage unless otherwise noted.

Torque Measurement

Torque	Torque	Meter reading
Forward	CQ-102C	30 to 65g•cm (0.42 to 0.9 oz•inch)
Forward back tension	CQ-102C	1 to 6g•cm (0.014 to 0.08 oz•inch)
Reverse	CQ-102RC	30 to 65g•cm (0.42 to 0.9 oz•inch)
Reverse back tension	CQ-102RC	1 to 6g•cm (0.014 to 0.08 oz•inch)
FF/REW	CQ-201B	70 to 120g•cm (0.98 to 1.67 oz•inch)

5-2. ELECTRICAL ADJUSTMENTS

PRECAUTION

- The adjustment should be performed in the publication.
(Be sure to make playback adjustment at first.)
- The adjustments and measurement should be performed for both L-CH and R-CH.
 - Switch position

DOLBY NR switch	: OFF
DIR MODE switch	: ⇄
 - Standard record position:
Deliver the standard input signal level to input jack and set the REC LEVEL control to obtain the standard output signal level as follows.

— Record Mode —

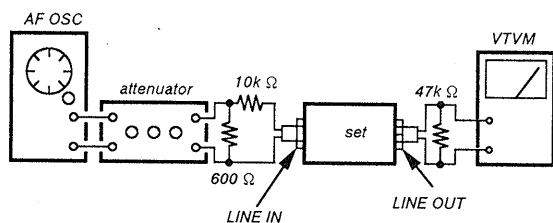

Standard Input Level

Input terminal	LINE IN
source impedance	10k Ω
input signal level	0.5V (- 3.8dB)

Standard Output Level

Output terminal	LINE OUT
load impedance	47k Ω
output signal level	0.5V (- 3.8dB)

Test Tape

Tape	Contents	Use
P-4-A100	10kHz, - 10dB	Azimuth Adjustment
P-4-L300	315Hz, 0dB	PB Level Adjustment
WS-48B	3kHz, 0dB	Tape Speed Adjustment

0dB=0.775V

Test Mode

- Insert a short-circuit plug into TP801 (2P) and turn ON the power switch. (Earth pin ⑤ of IC801 and turn ON the power switch.)
The memory is turned ON when the recording starts, and the counter starts counting from "0000".
When applying +5V to pin ⑤ of IC801, the FL tube will be fully lit.
- To release the test mode, remove the short plug and turn off the power switch.
- Remove the short plug after completion of adjustment.

Record/Playback Head Azimuth Adjustment

Procedure :

- Forward playback Mode

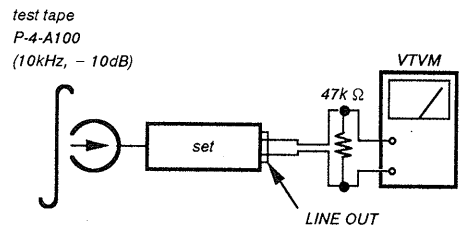

- Turn the adjustment screw for the maximum output levels. If these levels do not match, turn the adjustment screw until both of output levels match together within 1dB.

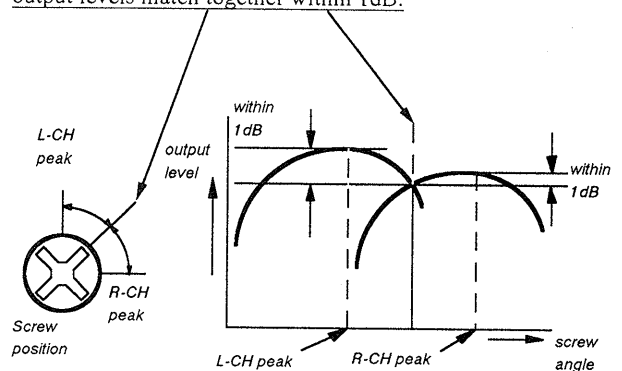

3. Playback Mode

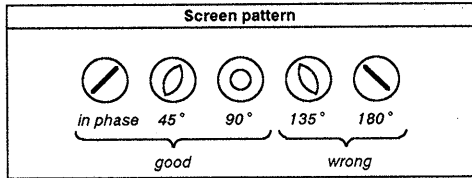
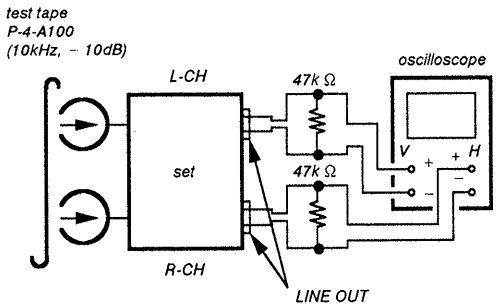

4. Change the reverse playback mode and repeat the steps 1 to 3.
5. After the adjustment, lock the adjustment screws with suitable locking compound.

Adjustment Location : – record/playback head –

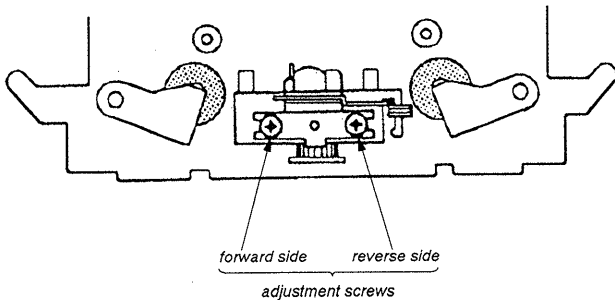

Tape Speed Adjustment

Procedure :

– Forward Playback Mode –

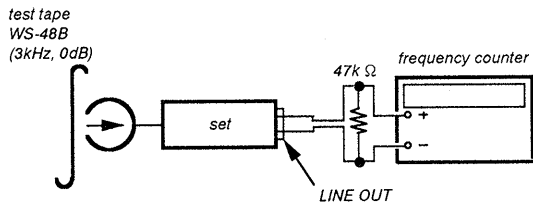

1. Set to FWD playback mode.
2. Adjust RV71 so that the frequency counter reading becomes $3,000 \pm 10\text{Hz}$.

Frequency difference between the beginning and the end of the tape should be within 3%.

Adjustment Location : AUDIO board

Playback Level Adjustment

Procedure :

– Forward Playback Mode –

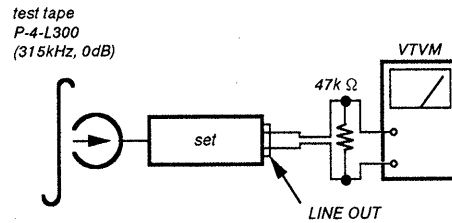

Adjust RV11(L-CH) and RV21(R-CH) so the VTVM reading becomes the adjustment limits below.

Adjustment Value :

LINE OUT level : $-7.7 \pm 0.5\text{dB}$ (0.301 to 0.338V)

Level difference between channels : within 0.5dB

Confirm the LINE OUT level does not change in playback mode while changing the mode from playback to stop several times

Adjustment Location : AUDIO board

Bias Consumption Current Adjustment

This adjustment should be performed when replacing the head assy or the bias oscillating transformer (T81, T91).

Procedure :

() : R-CH

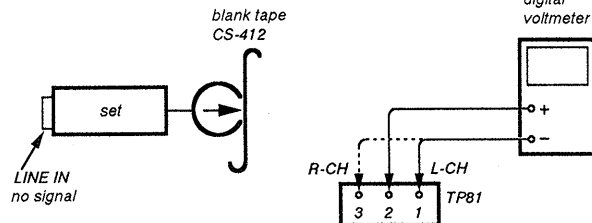

1. Connect the digital voltmeter to test point TP81.
2. Set RV81 (RV91) to mechanical center.
3. Set to FWD record mode.
4. Adjust T81 (T91) so that the digital voltmeter reading becomes minimum.

Adjustment Location : AUDIO board

Record Bias Adjustment

Setting :

REC LEVEL control : standard record position (Refer to page 11.)

Procedure :

1. Record Mode

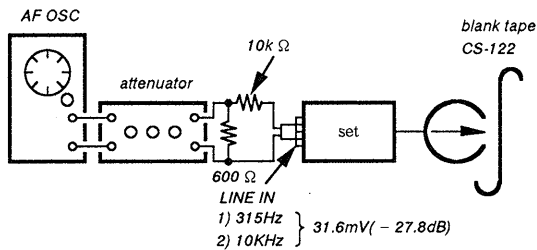

2. Playback Mode

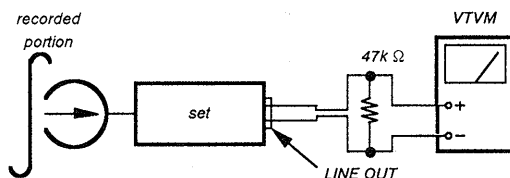

Confirm that the 10kHz playback output is $0 \pm 0.5\text{dB}$ relative to the 315Hz output. If necessary, adjust RV81(L-CH), RV91(R-CH) and repeat the steps given above.

Adjustment Location : AUDIO board

Record Level Adjustment

Setting :

REC LEVEL control : standard record position (Refer to page 11.)

Procedure :

1. Record Mode

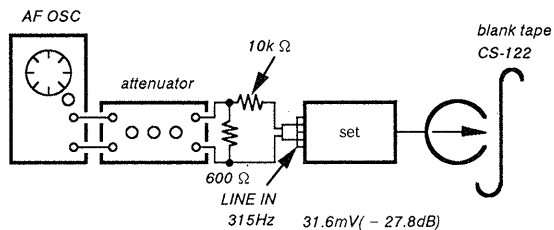

2. Playback Mode

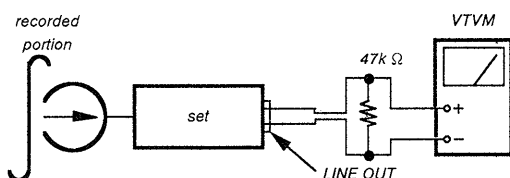

Confirm playback the tape recorded become adjustment level as follows.

If necessary, adjust RV121(L-CH), RV221(R-CH) and repeat the steps 1 and 2.

Adjustment Value :

LINE OUT level : $-26 \pm 0.5\text{dB}$ (36.7 to 41.1mV)

Adjustment Location : SYSTEM CONTROL

– Adjustment Parts Location Diagrams –

[SYSTEM CONTROL BOARD]

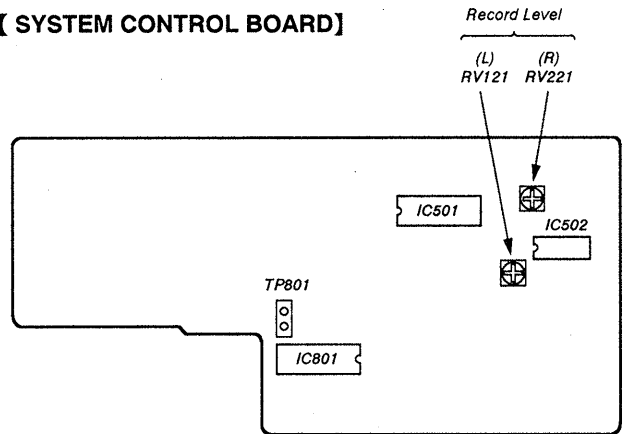

[AUDIO BOARD]

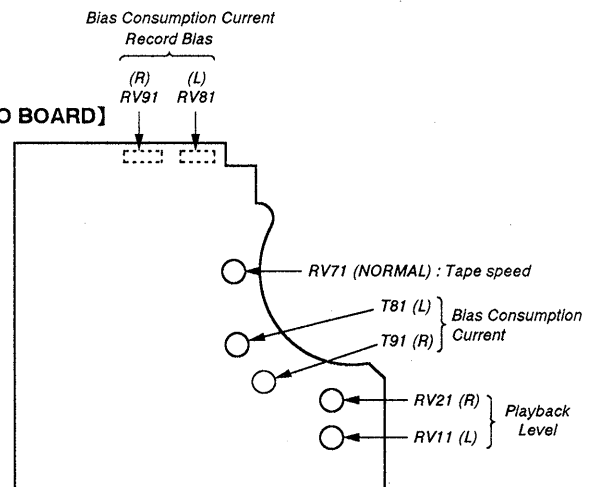

SECTION 6 DIAGRAMS

6-1. CIRCUIT BOARDS LOCATION

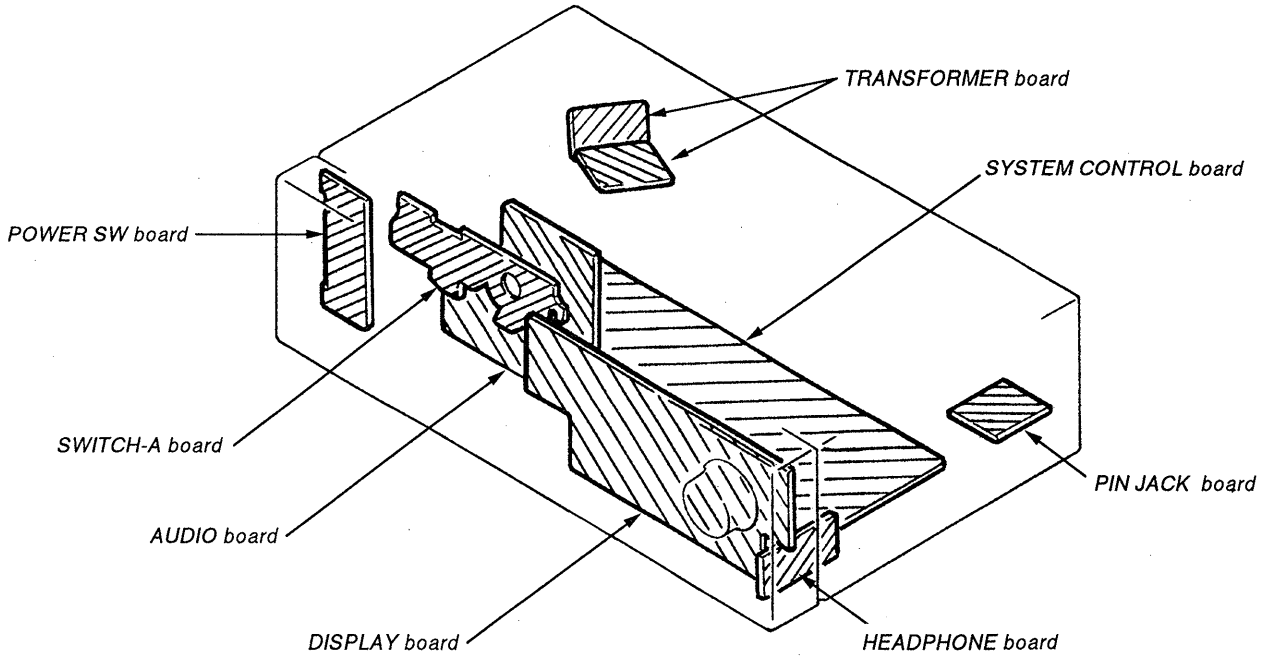

6-2. PRINTED WIRING BOARDS

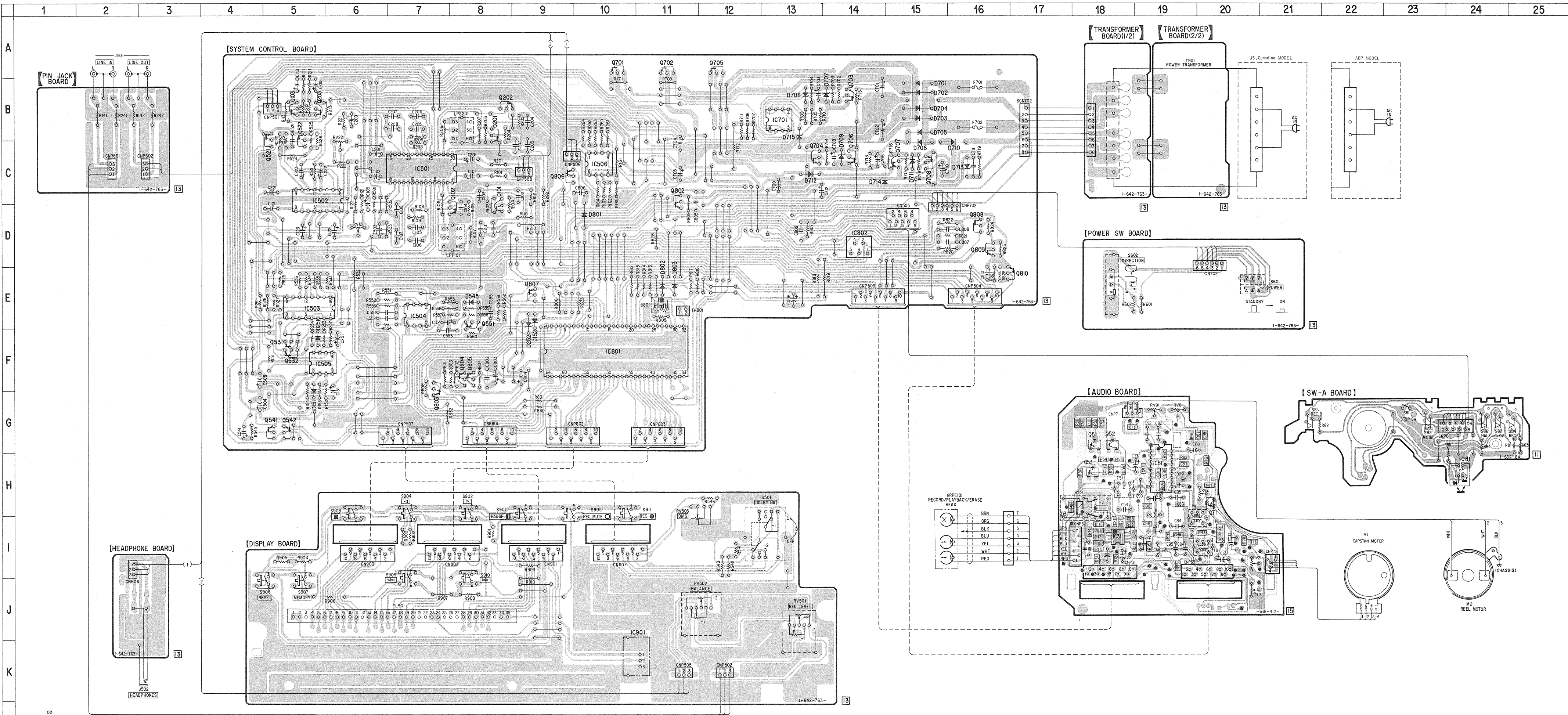

• SEMICONDUCTOR LOCATION

Ref. No.	Location	Ref. No.	Location
D31	H - 17	Q51	G - 18
D151	G - 5	Q52	G - 18
D152	E - 9	Q53	H - 18
D251	F - 5	Q71	H - 20
D252	E - 9	Q101	D - 8
D545	E - 8	Q102	D - 8
D701	B - 15	Q103	B - 5
D702	B - 15	Q201	B - 8
D703	B - 15	Q202	B - 8
D704	B - 15	Q203	B - 5
D705	B - 15	Q521	B - 5
D706	C - 15	Q522	B - 5
D707	B - 14	Q531	F - 5
D708	B - 13	Q532	F - 5
D709	C - 14	Q541	G - 5
D710	C - 16	Q542	G - 5
D711	B - 15	Q551	E - 8
D712	C - 13	Q701	A - 10
D713	C - 16	Q702	A - 11
D714	C - 14	Q703	B - 14
D715	B - 13	Q704	C - 13
D801	D - 10	Q705	A - 12
D802	E - 11	Q706	C - 14
D803	E - 11	Q707	B - 15
		Q708	B - 15
IC31	I - 18	Q802	C - 11
IC81	H - 19	Q803	F - 7
IC81	(AUDIO)	Q804	F - 8
IC81	H - 24	Q805	F - 8
IC501	C - 7	Q806	C - 9
IC502	C - 5	Q807	E - 9
		Q808	D - 16
IC503	E - 5	Q809	D - 16
IC504	E - 7	Q810	E - 16
IC505	F - 5		
IC506	C - 10		
IC701	B - 13		
IC801	F - 10		
IC802	D - 14		
IC901	K - 11		

Note:

- : parts extracted from the component side.
- : parts mounted on the conductor side.
- : Through hole.
- ▨ : Pattern on the side which is seen.
- ▧ : Pattern of the rear side.
- : Chip components extracted from the rear side.

• Semiconductor Lead Layouts.

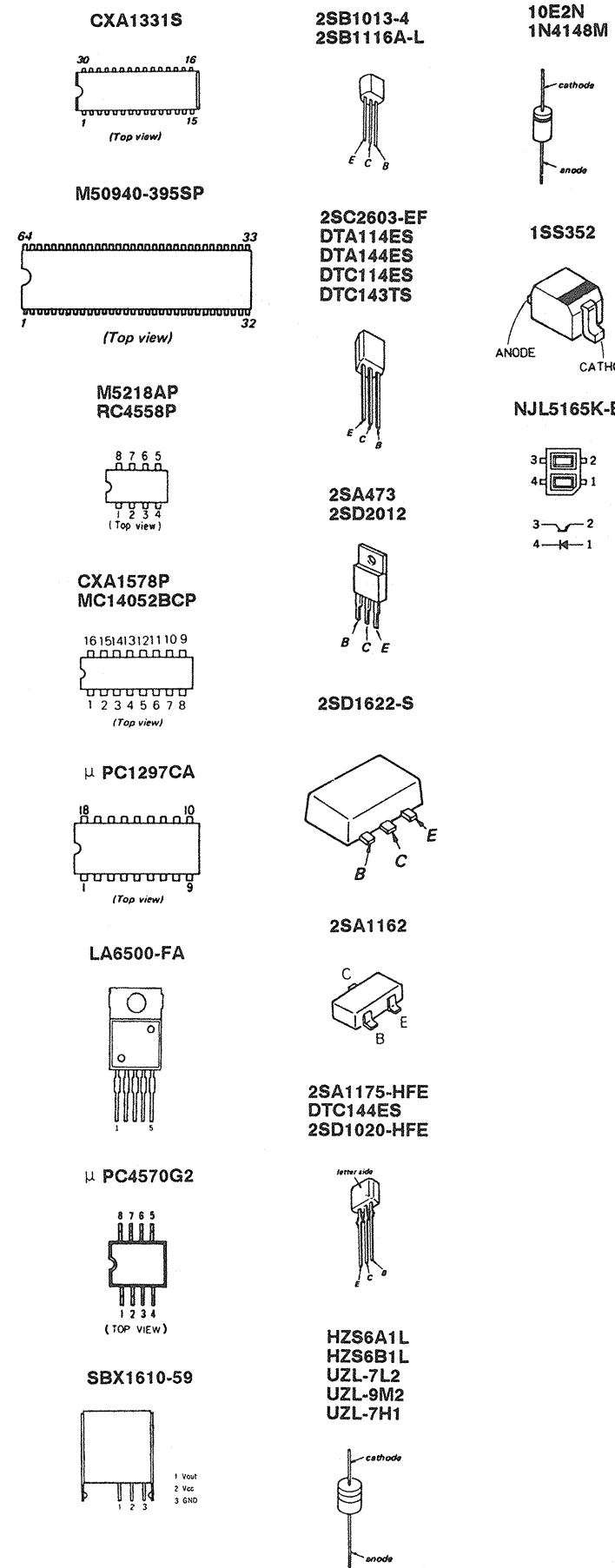

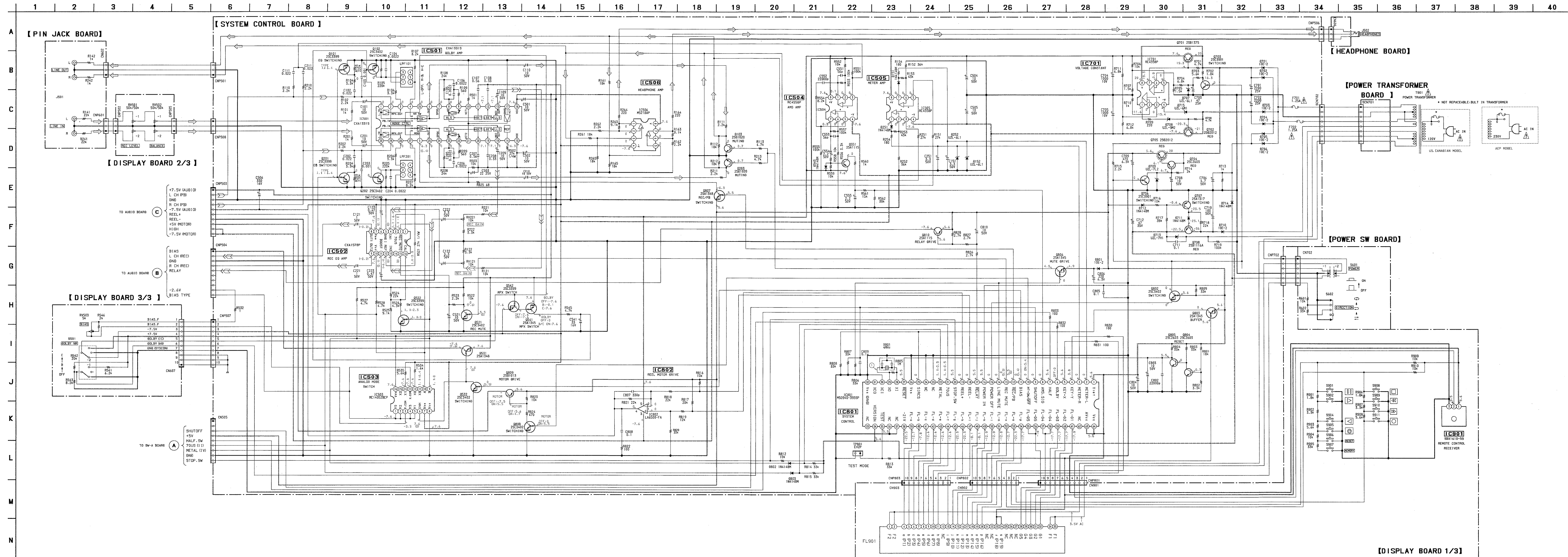

Note :

- All capacitors are in μ F unless otherwise noted. pF: μ μ F
- 50WV or less are not indicated except for electrolytics and tantalums.
- All resistors are in Ω and $\frac{1}{4}$ W or less unless otherwise specified.
- % : indicates tolerance.
- Δ : internal component.

Note :
The components identified by mark Δ or dotted line with mark Δ are critical for safety. Replace only with part number specified.

Note :
Les composants identifiés par une marque Δ sont critiques pour la sécurité. Ne les remplacer que par une pièce portant le numéro spécifié.

• — : B+ Line
• - - - : B- Line
• □ : adjustment for repair.
• ※ : selected to yield optimum performance.
• Voltage and waveforms are dc with respect to ground under no-signal conditions.
no mark : STOP
() : REC
• Voltages are taken with a VOM (Input impedance 10M Ω). Voltage variations may be noted due to normal production tolerances.
• Signal path.
• PB
• REC

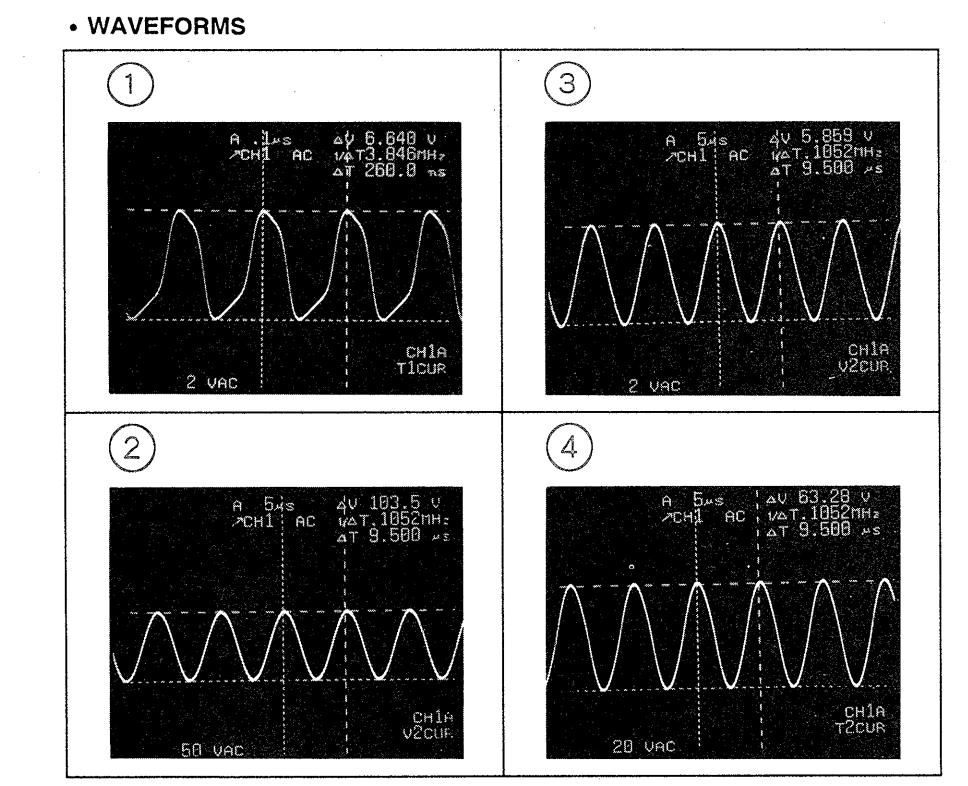

6-4. SCHEMATIC DIAGRAM (AUDIO SECTION)

• Refer to page 23 for note.

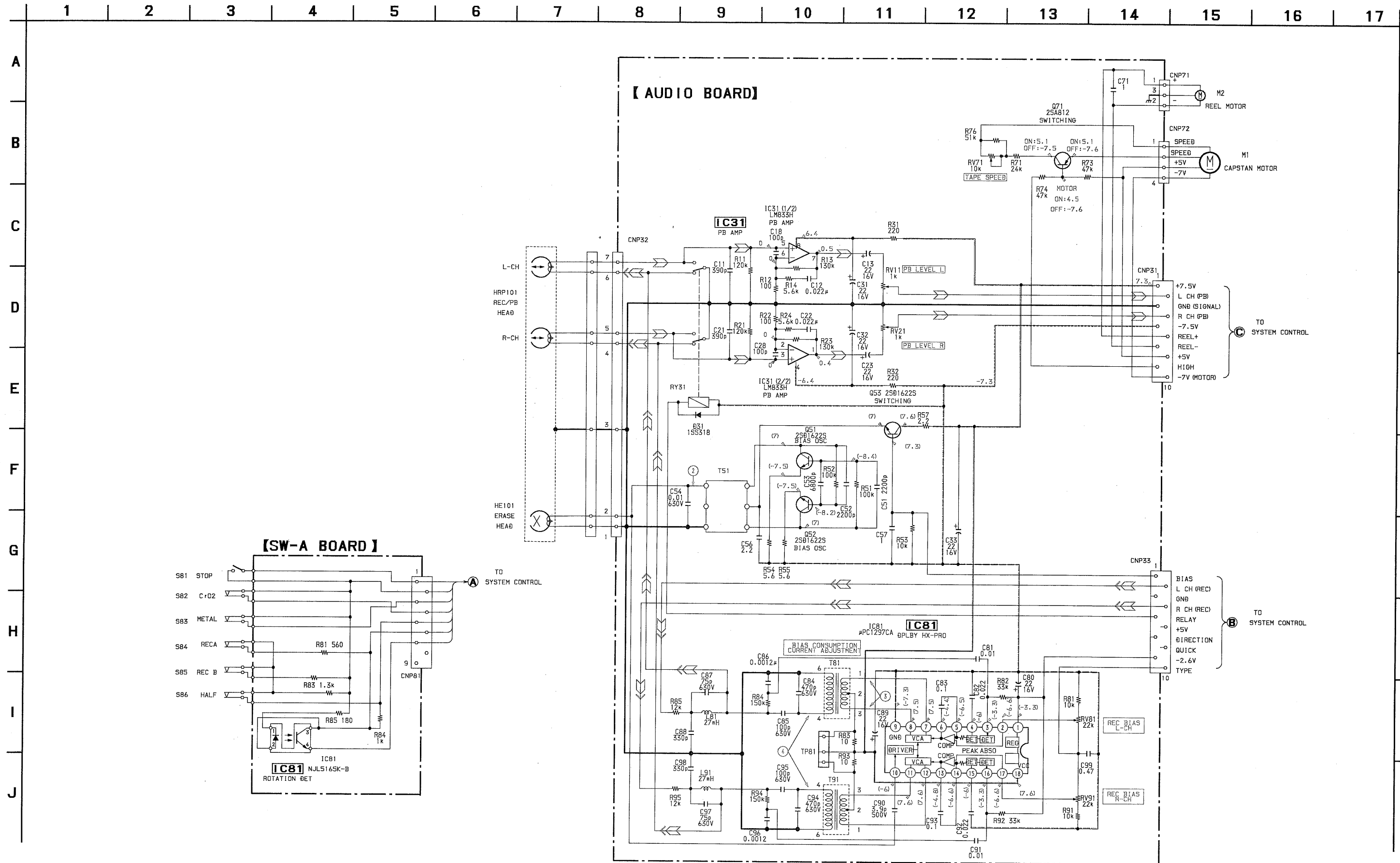

• IC BLOCK DIAGRAM

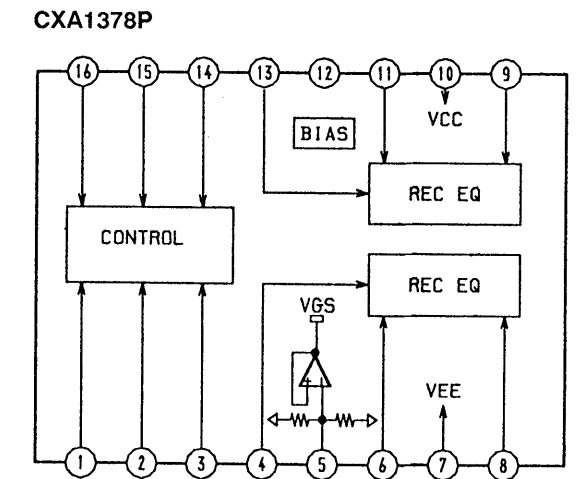

SECTION 7 EXPLODED VIEWS

NOTE:

- -XX, -X mean standardized parts, so they may have some differences from the original one.
- The construction parts of an assembled part are indicated with a collation number in the remark column.
- Color indication of Appearance Parts
Example:
KNOB, BALANCE (WHITE).... (RED)

↑ Parts color ↑ Cabinet's color

- Items marked "*" are not stocked since they are seldom required for routine service. Some delay should be anticipated when ordering these items.
- The mechanical parts with no reference number in the exploded views are not supplied.
- Hardware (# mark) list is given in the last of this parts list.

The components identified by mark **▲** or dotted line with mark **▲** are critical for safety. Replace only with part number specified.

Les composants identifiés par une marque **▲** sont critiques pour la sécurité. Ne les remplacer que par une pièce portant le numéro spécifié.

7-1. CHASSIS SECTION

- A : TRANSFORMER board
- B : PIN JACK board

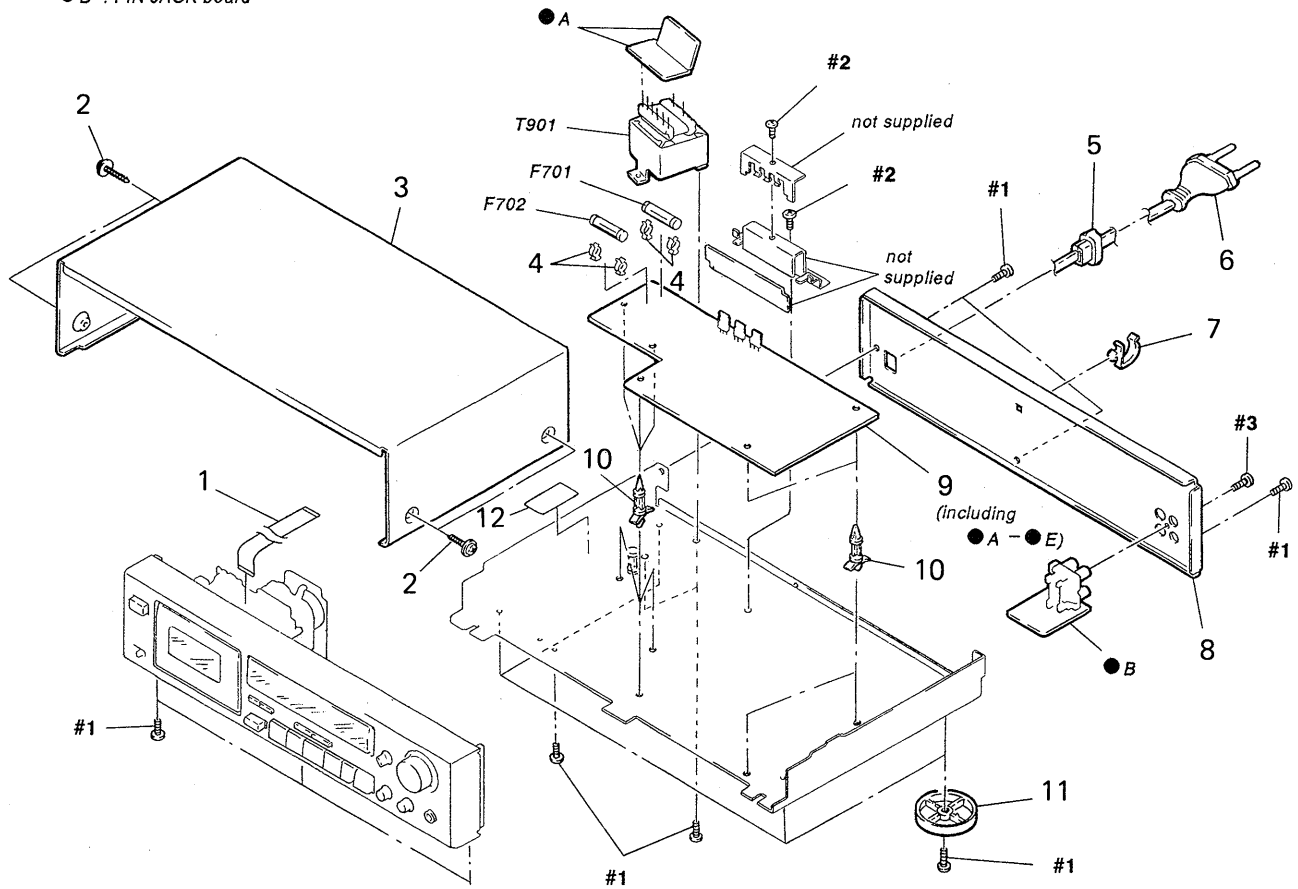

Ref.No.	Part No.	Description	Remark
1	1-575-781-11	WIRE, FLAT TYPE (9 CORE)	
2	3-704-366-01	SCREW (CASE) (M3X8)	
3	3-332-578-42	CASE	
* 4	1-533-213-31	HOLDER, FUSE	
* 5	3-703-244-00	BUSHING (2104), CORD (AEP)	
* 5	3-703-571-11	BUSHING (S) (4516), CORD (US, Canadian)	
▲ 6	1-555-795-00	CORD, POWER, EULO PLUG (AEP)	
▲ 6	1-558-945-11	CORD, POWER (POLAR. SPT-1) (US, Canadian)	
* 7	4-949-235-01	HOOK	
* 8	3-377-944-01	PANEL, BACK (US, Canadian)	
* 8	3-377-944-11	PANEL, BACK (AE1)	
* 8	3-377-944-21	PANEL, BACK (AE2)	

Ref.No.	Part No.	Description	Remark
* 9	A-2006-786-A	SYSTEM CONTROL BOARD, COMPLETE	
* 10	3-346-265-11	HOLDER, PC BOARD	
11	4-943-148-32	FOOT (F58175SW) (US, Canadian)	
11	4-943-148-42	FOOT (F58175SW) (AEP)	
* 12	3-703-044-26	LABEL, CAUTION (US, Canadian)	
▲ F701	1-532-285-00	FUSE, TIME-LAG (AEP)	
▲ F701	1-532-741-11	FUSE, GLASS TUBE (US, Canadian)	
▲ F702	1-532-285-00	FUSE, TIME-LAG (AEP)	
▲ F702	1-532-741-11	FUSE, GLASS TUBE (US, Canadian)	
▲ T901	1-450-750-11	TRANSFORMER, POWER (AEP)	
▲ T901	1-450-751-11	TRANSFORMER, POWER (US, Canadian)	

7-2. FRONT PANEL SECTION

- C : POWER SW board
- D : HEADPHONE board
- E : DISPLAY board

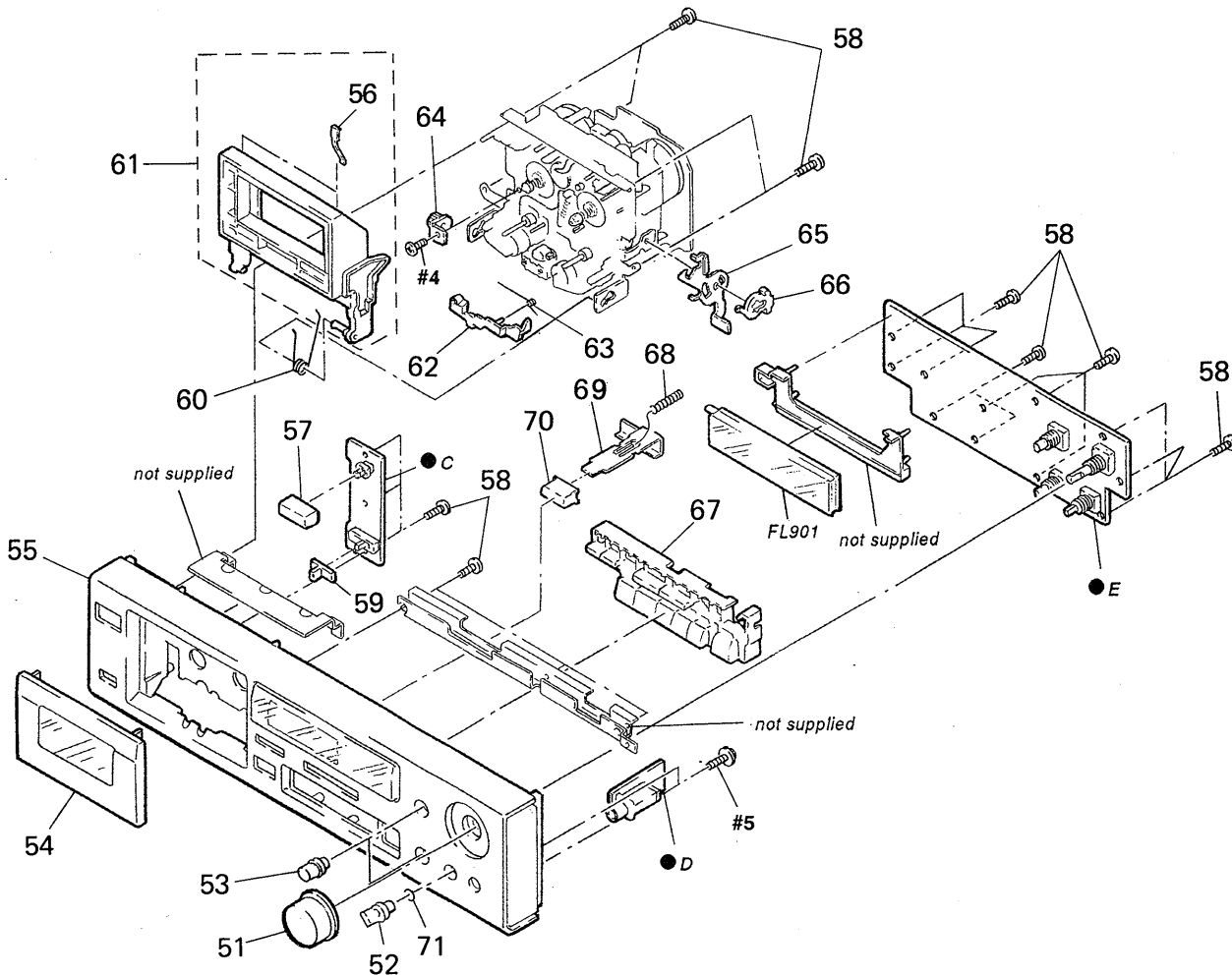

Ref.No.	Part No.	Description	Remark
51	3-367-438-11	KNOB (REC)	
52	3-380-950-01	KNOB (VOL)	
53	3-367-431-01	KNOB (BAL)	
54	X-3365-338-1	LID (R) ASSY, CASSETTE	
55	X-3365-337-1	PANEL ASSY, FRONT (AEP)	
56	X-3365-339-1	PANEL ASSY, FRONT (US, Canadian)	
57	3-308-823-11	SPRING	
58	4-922-921-01	BUTTON (POWER)	
58	4-951-620-01	SCREW (2.6X8), +BVTP	
59	4-931-421-11	KNOB (T & S)	
60	3-354-960-01	SPRING (LOADING R), TORSION	
61	X-3340-195-1	HOLDER (R) ASSY, CASSETTE (AEP)	

Ref.No.	Part No.	Description	Remark
61	X-3365-324-1	HOLDER (R) ASSY, CASSETTE (US, Canadian)	
62	3-354-956-01	LEVER (EJ SAFTY LEVER R)	
63	3-354-962-01	SPRING (EJ SAFTY SPRING R)	
64	3-354-963-01	DAMPER	
* 65	3-354-954-01	LEVER (LOCK LEVER R)	
66	3-354-957-01	JOINT (LOCK LEVER)	
67	3-367-434-31	BUTTON (A)	
68	3-359-906-01	SPRING, COMPRESSION	
* 69	3-370-068-01	SLIDER (EJECT)	
70	3-370-067-01	BUTTON (EJECT)	
71	3-356-935-01	SPRING	
FL901	1-519-713-11	INDICATOR TUBE, FLUORESCENT	

7-3. MECHANISM SECTION 1
(TCM-190RB12CJ)

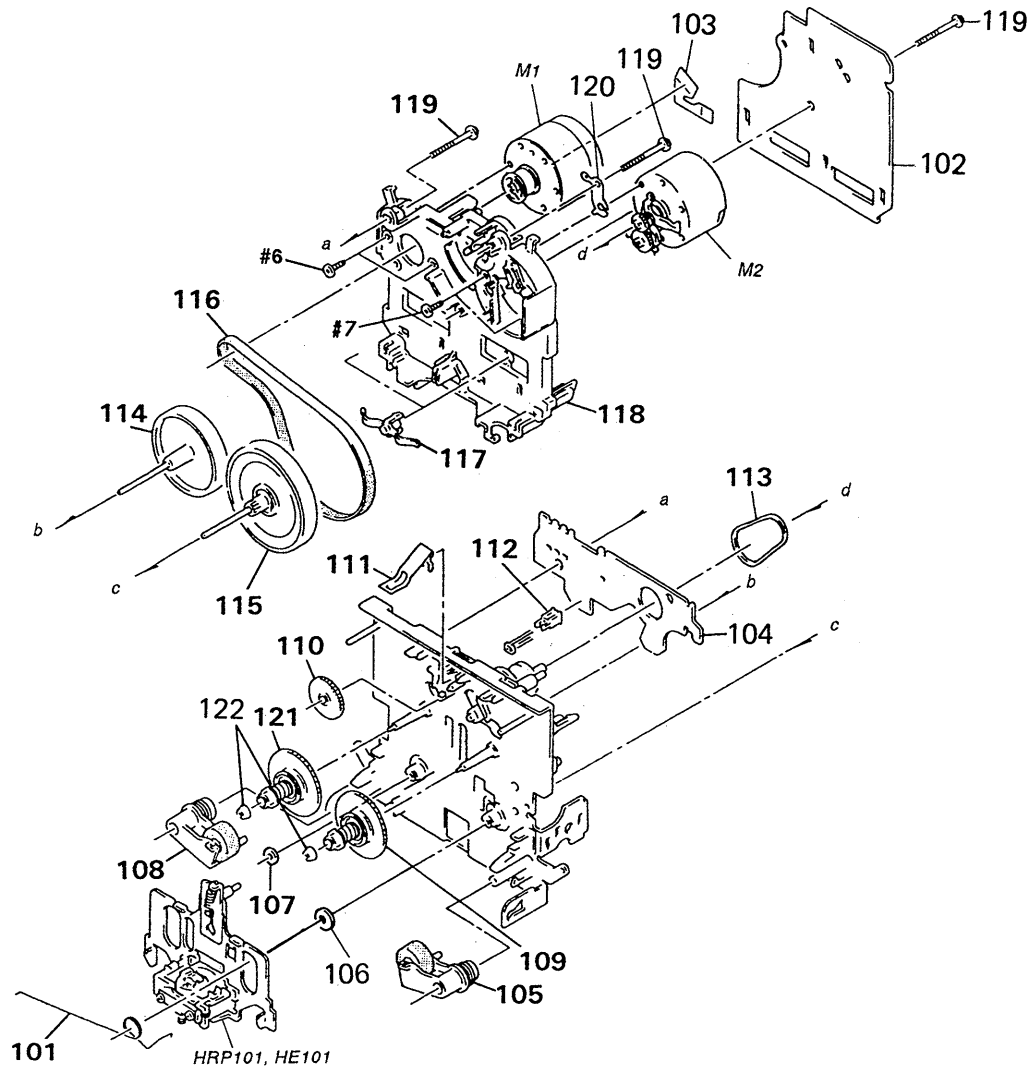

Ref. No.	Part No.	Description	Remark
101	3-359-455-01	SPRING, TORSION	
* 102	A-2006-828-A	AUDIO BOARD, COMPLETE	
103	1-638-983-11	PC BOARD, MOTOR FLEXIBLE	
* 104	1-634-841-14	SW-A BOARD	
105	X-3359-408-1	LEVER (PINCH LEVER FWD) ASSY	
106	3-356-713-01	WASHER	
107	3-356-714-01	WASHER	
108	X-3359-409-1	LEVER (PINCH LEVER REV) ASSY	
109	X-3359-404-1	TABLE ASSY, REEL	
110	3-359-424-01	GEAR (REV GEAR)	
111	3-359-430-01	SPRING(CASSETTE RETAINER), LEAF	

Ref. No.	Part No.	Description	Remark
112	3-343-419-01	HOLDER (S SENSER A)	
113	3-359-466-01	BELT (FR), SQUARE	
114	X-3359-410-1	FLYWHEEL (REV) ASSY	
115	X-3364-554-1	FLYWHEEL (FWD) ASSY	
116	3-359-417-01	BELT (FLAT), CAPSTAN	
117	3-575-321-00	RETAINER, THRUST, CAPSTAN	
* 118	3-359-436-01	BASE (THRUST RETAINER), FITTING	
119	3-359-414-01	SCREW (+PTPWH 2X23)	
120	3-359-450-01	PLATE, GROUND	
121	X-3362-078-1	TABLE ASSY (B), REEL	
122	3-362-308-01	CAP (REEL)	
HE101	A-2003-838-A	BASE ASSY, HEAD (ERASE)	
HRP101	A-2003-838-A	BASE ASSY, HEAD (PB/REC)	
M1	X-3359-417-1	MOTOR ASSY, CAPSTAN	
M2	X-3363-501-1	MOTOR ASSY, REEL	

7-4. MECHANISM SECTION 2
(TCM-190RB12CJ)

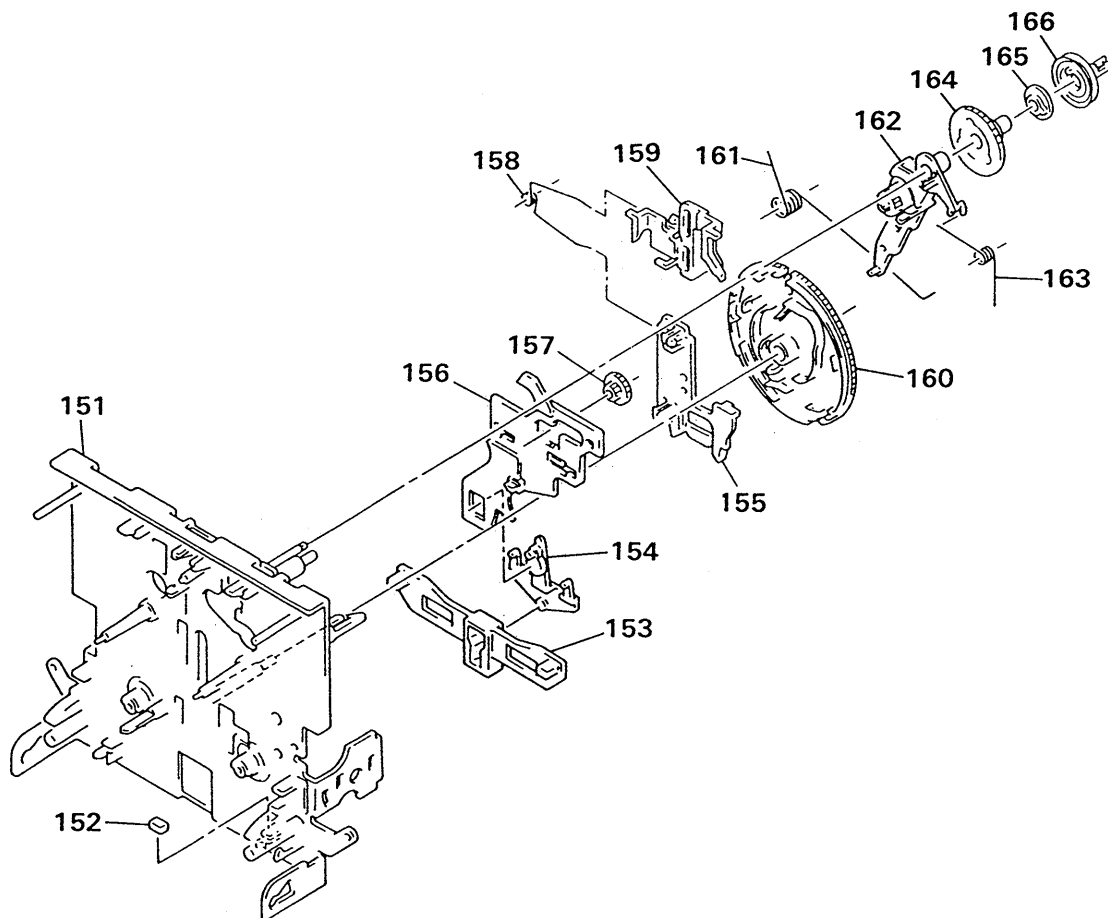

Ref.No.	Part No.	Description	Remark	Ref.No.	Part No.	Description	Remark
151	X-3359-415-1	CHASSIS ASSY, MECHANICAL		160	3-359-420-01	GEAR (CAM GEAR)	
152	3-359-469-01	SPACER		161	3-359-456-01	SPRING (TRIGGER SPRING), TORSION	
* 153	3-359-425-01	SLIDER (REVERSE SLIDER)		162	X-3359-405-1	LEVER (FR ARM) ASSY	
154	3-359-426-01	LEVER (REVERSE LEVER)		163	3-359-453-01	SPRING (FR ARM), TORSION	
* 155	3-359-427-01	SLIDER (LEVERSE SLIDER)		164	3-359-419-01	GEAR (FR GEAR)	
* 156	3-359-415-01	SLIDER (TRIGGER SLIDER)		165	3-359-421-01	CLUTCH (REEL DISK)	
157	3-359-448-01	GEAR (TRIGGER)		166	3-359-418-01	PULLEY (FR PULLEY)	
158	3-359-454-01	SPRING, TORSION					
159	3-359-429-01	SLIDER (BRAKE PLATE)					

SECTION 8
ELECTRICAL PARTS LIST

AUDIO

NOTE:

- Due to standardization, replacements in the parts list may be different from the parts specified in the diagrams or the components used on the set.
- -XX, -X mean standardized parts, so they may have some difference from the original one.
- RESISTORS
All resistors are in ohms
METAL: Metal-film resistor
METAL OXIDE: Metal oxide-film resistor
F: nonflammable

- Items marked "*" are not stocked since they are seldom required for routine service. Some delay should be anticipated when ordering these items.
- SEMICONDUCTORS
In each case, u: μ , for example:
uA....: μ A...., uPA....: μ PA....
uPB....: μ PB...., uPC....: μ PC....
uPD....: μ PD....
- CAPACITORS
uF: μ F
- COILS
uH: μ H

The components identified by mark Δ or dotted line with mark Δ are critical for safety. Replace only with part number specified.

Les composants identifiés par une marque Δ sont critiques pour la sécurité. Ne les remplacer que par une pièce portant le numéro spécifié.

When indicating parts by reference number, please include the board.

Ref.No.	Part No.	Description	Remark	Ref.No.	Part No.	Description	Remark
*	A-2006-828-A	AUDIO BOARD, COMPLETE *****					
		< CAPACITOR >					
C11	1-163-131-00	CERAMIC CHIP 390PF	5% 50V	C92	1-136-157-00	FILM 0.022uF	5% 50V
C12	1-136-157-00	FILM 0.022uF	5% 50V	C93	1-164-004-11	CERAMIC CHIP 0.1uF	10% 25V
C13	1-124-234-00	ELECT 22uF	20% 16V	C94	1-136-478-11	FILM 470PF	5% 630V
C18	1-163-117-00	CERAMIC CHIP 100PF	5% 50V	C95	1-136-433-11	FILM 100PF	5% 630V
C21	1-163-131-00	CERAMIC CHIP 390PF	5% 50V	C96	1-163-143-00	CERAMIC CHIP 0.0012uF	5% 50V
C22	1-136-157-00	FILM 0.022uF	5% 50V				
C23	1-124-234-00	ELECT 22uF	20% 16V	C97	1-136-273-91	FILM 75PF	5% 630V
C28	1-163-117-00	CERAMIC CHIP 100PF	5% 50V	C98	1-163-003-11	CERAMIC CHIP 330PF	10% 50V
C31	1-124-234-00	ELECT 22uF	20% 16V	C99	1-164-005-11	CERAMIC CHIP 0.47uF	25V
C32	1-124-234-00	ELECT 22uF	20% 16V				
C33	1-124-234-00	ELECT 22uF	20% 16V				
C51	1-164-161-11	CERAMIC CHIP 0.0022uF	10% 100V				
C52	1-164-161-11	CERAMIC CHIP 0.0022uF	10% 100V				
C53	1-163-019-00	CERAMIC CHIP 0.0068uF	10% 50V				
C54	1-136-601-11	FILM 0.01uF	5% 630V				
C56	1-164-505-11	CERAMIC CHIP 2.2uF	16V				
C57	1-164-346-11	CERAMIC CHIP 1uF	16V				
C71	1-164-346-11	CERAMIC CHIP 1uF	16V				
C80	1-124-234-00	ELECT 22uF	20% 16V				
C81	1-164-232-11	CERAMIC CHIP 0.01uF	50V				
C82	1-136-157-00	FILM 0.022uF	5% 50V				
C83	1-164-004-11	CERAMIC CHIP 0.1uF	10% 25V				
C84	1-136-478-11	FILM 470PF	5% 630V				
C85	1-136-433-11	FILM 100PF	5% 630V				
C86	1-163-143-00	CERAMIC CHIP 0.0012uF	5% 50V				
C87	1-136-273-91	FILM 75PF	5% 630V				
C88	1-163-003-11	CERAMIC CHIP 330PF	10% 50V				
C89	1-124-234-00	ELECT 22uF	20% 16V				
C90	1-107-045-00	MICA 3.9PF	500V				
C91	1-164-232-11	CERAMIC CHIP 0.01uF	50V				
		< CONNECTOR >					
		* CNP31 1-580-782-11	CONNECTOR, BOARD TO BOARD				
		* CNP32 1-580-781-11	PIN, CONNECTOR (PC BOARD) 7P				
		* CNP33 1-580-782-11	CONNECTOR, BOARD TO BOARD				
		* CNP71 1-564-719-11	PIN, CONNECTOR (SMALL TYPE) 3P				
		* CNP72 1-580-411-11	SOCKET, CONNECTOR 4P				
		* CNP75 1-564-718-11	PIN, CONNECTOR (SMALL TYPE) 2P				
		< DIODE >					
		D31 8-719-016-74	DIODE 1SS352				
		< IC >					
		IC31 8-759-106-02	IC uPC4570G2				
		IC81 8-759-106-56	IC uPC1297CA				
		< COIL >					
		L81 1-410-780-11	INDUCTOR 27mH				
		L91 1-410-780-11	INDUCTOR 27mH				
		< TRANSISTOR >					
		Q51 8-729-808-01	TRANSISTOR 2SD1622-S				
		Q52 8-729-808-01	TRANSISTOR 2SD1622-S				
		Q53 8-729-808-01	TRANSISTOR 2SD1622-S				
		Q71 8-729-216-22	TRANSISTOR 2SA1162				

AUDIO

SW-A

SYSTEM CONTROL

Ref.No.	Part No.	Description	Remark		
< RESISTOR >					
R11	1-216-099-00	METAL CHIP	120K	5%	1/10W
R12	1-216-025-00	METAL CHIP	100	5%	1/10W
R13	1-216-100-00	METAL GLAZE	130K	5%	1/10W
R14	1-216-067-00	METAL CHIP	5.6K	5%	1/10W
R21	1-216-099-00	METAL CHIP	120K	5%	1/10W
R22	1-216-025-00	METAL CHIP	100	5%	1/10W
R23	1-216-100-00	METAL GLAZE	130K	5%	1/10W
R24	1-216-067-00	METAL CHIP	5.6K	5%	1/10W
R31	1-216-033-00	METAL CHIP	220	5%	1/10W
R32	1-216-033-00	METAL CHIP	220	5%	1/10W
R51	1-216-097-00	METAL CHIP	100K	5%	1/10W
R52	1-216-097-00	METAL CHIP	100K	5%	1/10W
R53	1-216-073-00	METAL CHIP	10K	5%	1/10W
R54	1-216-309-00	METAL CHIP	5.6	5%	1/10W
R55	1-216-309-00	METAL CHIP	5.6	5%	1/10W
R57	1-216-298-00	METAL CHIP	2.2	5%	1/10W
R71	1-216-082-00	METAL GLAZE	24K	5%	1/10W
R72	1-216-081-00	METAL CHIP	22K	5%	1/10W
R73	1-216-089-00	METAL CHIP	47K	5%	1/10W
R74	1-216-089-00	METAL CHIP	47K	5%	1/10W
R76	1-216-090-00	METAL CHIP	51K	5%	1/10W
R81	1-216-073-00	METAL CHIP	10K	5%	1/10W
R82	1-216-085-00	METAL CHIP	33K	5%	1/10W
R83	1-216-001-00	METAL CHIP	10	5%	1/10W
R84	1-216-101-00	METAL CHIP	150K	5%	1/10W
R85	1-216-075-00	METAL CHIP	12K	5%	1/10W
R91	1-216-073-00	METAL CHIP	10K	5%	1/10W
R92	1-216-085-00	METAL CHIP	33K	5%	1/10W
R93	1-216-001-00	METAL CHIP	10	5%	1/10W
R94	1-216-101-00	METAL CHIP	150K	5%	1/10W
R95	1-216-075-00	METAL CHIP	12K	5%	1/10W
< VARIABLE RESISTOR >					
RV11	1-241-627-11	RES, ADJ, CARBON 1K (PB LEVEL)			
RV21	1-241-627-11	RES, ADJ, CARBON 1K (PB LEVEL)			
RV71	1-241-630-11	RES, ADJ, CARBON 10K (TAPE SPEED)			
RV72	1-241-630-11	RES, ADJ, CARBON 10K (TAPE SPERD)			
RV81	1-241-122-11	RES, ADJ, CARBON 22K (REC BIAS)			
RV91	1-241-122-11	RES, ADJ, CARBON 22K (REC BIAS)			
< RELAY >					
RY31	1-515-803-11	RELAY			
< TRANSFORMER >					
T51	1-406-417-11	COIL, BIAS OSCILLATION			
T81	1-433-381-11	TRANSFORMER, BIAS OSCILLATOR			

Ref.No.	Part No.	Description	Remark		
T91	1-433-381-11	TRANSFORMER, BIAS OSCILLATOR			
< CONNECTOR >					
* TP81	1-568-449-11	HOUSING, CONNECTOR(PC BOARD)3P			

*	1-634-841-14	SW-A BOARD			

	3-343-419-01	HOLDER (S SENSER A)			
< CONNECTOR >					
* CNP81	1-568-852-11	SOCKET, CONNECTOR 9P			
< IC >					
IC81	8-719-710-03	DIODE NJL5165K-B			
< RESISTOR >					
R81	1-249-414-11	CARBON	560	5%	1/4W
R82	1-247-818-11	CARBON	300	5%	1/4W
R83	1-247-834-11	CARBON	1.3K	5%	1/4W
R84	1-249-417-11	CARBON	1K	5%	1/4W
R85	1-249-408-11	CARBON	180	5%	1/4W
< SWITCH >					
S81	1-571-958-11	SWITCH, PUSH (1 KEY)(STOP)			
S82	1-571-281-21	SWITCH, LEAF (CrO2)			
S83	1-571-281-21	SWITCH, LEAF (METAL)			
S84	1-571-281-21	SWITCH, LEAF (REC A)			
S85	1-571-281-21	SWITCH, LEAF (REC B)			
S86	1-571-281-21	SWITCH, LEAF (HALF)			

*	A-2006-786-A	SYSTEM CONTROL BOARD, COMPLETE			

*	1-533-213-31	HOLDER, FUSE			
*	1-562-327-00	SOCKET, CONNECTOR 3P			
< CAPACITOR >					
C101	1-124-907-11	ELECT	10uF	20%	50V
C102	1-136-157-00	FILM	0.022uF	5%	50V
C103	1-130-471-00	MYLAR	0.001uF	5%	50V
C104	1-130-475-00	MYLAR	0.0022uF	5%	50V
C105	1-130-475-00	MYLAR	0.0022uF	5%	50V
C106	1-130-475-00	MYLAR	0.0022uF	5%	50V
C107	1-136-174-00	FILM	0.56uF	5%	50V
C108	1-136-171-00	FILM	0.33uF	5%	50V
C109	1-124-907-11	ELECT	10uF	20%	50V
C110	1-124-907-11	ELECT	10uF	20%	50V

SYSTEM CONTROL

Ref.No.	Part No.	Description	Remark		
C111	1-136-157-00	FILM	0.022uF	5%	50V
C121	1-124-903-11	ELECT	1uF	20%	50V
C122	1-123-382-00	ELECT	3.3uF	20%	100V
C123	1-124-465-00	ELECT	0.47uF	20%	50V
C151	1-123-382-00	ELECT	3.3uF	20%	100V
C201	1-124-907-11	ELECT	10uF	20%	50V
C202	1-136-157-00	FILM	0.022uF	5%	50V
C203	1-130-471-00	MYLAR	0.001uF	5%	50V
C204	1-130-475-00	MYLAR	0.0022uF	5%	50V
C205	1-130-475-00	MYLAR	0.0022uF	5%	50V
C206	1-130-475-00	MYLAR	0.0022uF	5%	50V
C207	1-136-174-00	FILM	0.56uF	5%	50V
C208	1-136-171-00	FILM	0.33uF	5%	50V
C209	1-124-907-11	ELECT	10uF	20%	50V
C210	1-124-907-11	ELECT	10uF	20%	50V
C211	1-136-157-00	FILM	0.022uF	5%	50V
C221	1-124-903-11	ELECT	1uF	20%	50V
C222	1-123-382-00	ELECT	3.3uF	20%	100V
C223	1-124-465-00	ELECT	0.47uF	20%	50V
C251	1-123-382-00	ELECT	3.3uF	20%	100V
C501	1-124-907-11	ELECT	10uF	20%	50V
C502	1-124-907-11	ELECT	10uF	20%	50V
C503	1-126-233-11	ELECT	22uF	20%	50V
C504	1-124-907-11	ELECT	10uF	20%	50V
C505	1-124-907-11	ELECT	10uF	20%	50V
C521	1-124-907-11	ELECT	10uF	20%	50V
C541	1-124-034-51	ELECT	33uF	20%	16V
C551	1-162-217-31	CERAMIC	56PF	5%	50V
C552	1-161-494-00	CERAMIC	0.022uF		25V
C553	1-162-217-31	CERAMIC	56PF	5%	50V
C554	1-124-925-11	ELECT	2.2uF	20%	100V
C555	1-124-925-11	ELECT	2.2uF	20%	100V
C701	1-124-563-11	ELECT	2200uF	20%	25V
C702	1-124-563-11	ELECT	2200uF	20%	25V
C703	1-124-477-11	ELECT	47uF	20%	25V
C704	1-124-473-11	ELECT	1000uF	20%	10V
C705	1-124-473-11	ELECT	1000uF	20%	10V
C706	1-124-927-11	ELECT	4.7uF	20%	100V
C708	1-124-907-11	ELECT	10uF	20%	50V
C709	1-124-472-11	ELECT	470uF	20%	10V
C710	1-124-122-11	ELECT	100uF	20%	50V
C711	1-164-159-11	CERAMIC	0.1uF		50V
C712	1-124-910-11	ELECT	47uF	20%	50V
C802	1-161-494-00	CERAMIC	0.022uF		25V
C803	1-124-907-11	ELECT	10uF	20%	50V
C804	1-124-907-11	ELECT	10uF	20%	50V
C805	1-164-159-11	CERAMIC	0.1uF		50V
C806	1-126-176-11	ELECT	220uF	20%	10V
C807	1-162-288-31	CERAMIC	330PF	10%	50V

Ref.No.	Part No.	Description	Remark		
C808	1-164-159-11	CERAMIC	0.1uF		50V
C809	1-164-159-11	CERAMIC	0.1uF		50V
C810	1-124-907-11	ELECT	10uF	20%	50V

< CONNECTOR >

* CN505	1-568-828-11	SOCKET, CONNECTOR 9P			
* CN607	1-580-782-11	CONNECTOR, BOARD TO BOARD			
* CN901	1-580-782-11	CONNECTOR, BOARD TO BOARD			
* CN902	1-580-782-11	CONNECTOR, BOARD TO BOARD			
* CN903	1-580-782-11	CONNECTOR, BOARD TO BOARD			
* CNP501	1-564-337-00	PIN, CONNECTOR 3P			
* CNP502	1-564-705-11	PIN, CONNECTOR (SMALL TYPE) 3P			
* CNP503	1-691-916-11	CONNECTOR, BOARD TO BOARD			
* CNP504	1-691-916-11	CONNECTOR, BOARD TO BOARD			
* CNP505	1-564-705-11	PIN, CONNECTOR (SMALL TYPE) 3P			
* CNP506	1-564-337-61	PIN, CONNECTOR 3P			
* CNP507	1-580-784-11	CONNECTOR, BOARD TO BOARD			
* CNP508	1-564-705-11	PIN, CONNECTOR (SMALL TYPE) 3P			
* CNP601	1-564-705-11	PIN, CONNECTOR (SMALL TYPE) 3P			
* CNP702	1-564-340-00	PIN, CONNECTOR 6P			
* CNP801	1-580-784-11	CONNECTOR, BOARD TO BOARD			
* CNP802	1-580-784-11	CONNECTOR, BOARD TO BOARD			
* CNP803	1-580-784-11	CONNECTOR, BOARD TO BOARD			

< DIODE >

D151	8-719-987-63	DIODE	1N4148M		
D152	8-719-933-33	DIODE	HZS6A1L		
D251	8-719-987-63	DIODE	1N4148M		
D252	8-719-933-33	DIODE	HZS6A1L		
D545	8-719-987-63	DIODE	1N4148M		
D701	8-719-200-77	DIODE	10E2N		
D702	8-719-200-77	DIODE	10E2N		
D703	8-719-200-77	DIODE	10E2N		
D704	8-719-200-77	DIODE	10E2N		
D705	8-719-200-77	DIODE	10E2N		
D706	8-719-200-77	DIODE	10E2N		
D707	8-719-933-33	DIODE	HZS6A1L		
D708	8-719-001-15	DIODE	UZL-9M2		
D709	8-719-000-78	DIODE	UZL-7L2		
D710	8-719-200-77	DIODE	10E2N		
D711	8-719-987-63	DIODE	1N4148M		
D712	8-719-987-63	DIODE	1N4148M		
D713	8-719-000-93	DIODE	UZL-7H1		
D714	8-719-987-63	DIODE	1N4148M		
D715	8-719-933-36	DIODE	HZS6B1L		
D801	8-719-200-77	DIODE	10E2N		
D802	8-719-987-63	DIODE	1N4148M		
D803	8-719-987-63	DIODE	1N4148M		

SYSTEM CONTROL

Ref. No.	Part No.	Description	Remark
		< INDICATOR TUBE >	
FL901	1-519-713-11	INDICATOR TUBE, FLUORESCENT	
		< IC >	
IC501	8-752-059-55	IC CXA1331S	
IC502	8-752-055-61	IC CXA1578P	
IC503	8-759-000-48	IC MC14052BCP	
IC504	8-759-945-58	IC RC4558P	
IC505	8-759-945-58	IC RC4558P	
IC506	8-759-634-51	IC M5218AP	
IC701	8-759-945-58	IC RC4558P	
IC801	8-759-065-44	IC M50940-395SP	
IC802	8-759-803-42	IC LA6500-FA	
IC901	8-741-100-48	IC SBX1610-59	
		< JACK >	
J501	1-565-258-11	JACK, PIN 4P (LINE IN/OUT)	
J502	1-568-519-41	JACK, LARGE TYPE (HEADPHONES)	
		< FILTER >	
LPF101	1-231-388-00	FILTER, LOW PASS	
LPF201	1-231-388-00	FILTER, LOW PASS	
		< TRANSISTOR >	
Q101	8-729-900-89	TRANSISTOR DTC144ES	
Q102	8-729-900-80	TRANSISTOR DTC114ES	
Q103	8-729-142-25	TRANSISTOR 2SD1020-HFE	
Q201	8-729-900-89	TRANSISTOR DTC144ES	
Q202	8-729-900-80	TRANSISTOR DTC114ES	
Q203	8-729-142-25	TRANSISTOR 2SD1020-HFE	
Q521	8-729-900-80	TRANSISTOR DTC114ES	
Q522	8-729-900-89	TRANSISTOR DTC144ES	
Q531	8-729-900-61	TRANSISTOR DTA114ES	
Q532	8-729-900-80	TRANSISTOR DTC114ES	
Q541	8-729-900-65	TRANSISTOR DTA144ES	
Q542	8-729-900-89	TRANSISTOR DTC144ES	
Q551	8-729-119-76	TRANSISTOR 2SA1175-HFE	
Q701	8-729-141-83	TRANSISTOR 2SA473	
Q702	8-729-209-15	TRANSISTOR 2SD2012	
Q703	8-729-900-74	TRANSISTOR DTC143TS	
Q704	8-729-620-05	TRANSISTOR 2SC2603-EF	
Q705	8-729-209-15	TRANSISTOR 2SD2012	
Q706	8-729-900-74	TRANSISTOR DTC143TS	
Q707	8-729-119-76	TRANSISTOR 2SA1175-HFE	
Q708	8-729-140-04	TRANSISTOR 2SB1116A-L	
Q802	8-729-900-80	TRANSISTOR DTC114ES	
Q803	8-729-900-65	TRANSISTOR DTA144ES	
Q804	8-729-620-05	TRANSISTOR 2SC2603-EF	

Ref. No.	Part No.	Description	Remark
Q805	8-729-620-05	TRANSISTOR 2SC2603-EF	
Q806	8-729-900-65	TRANSISTOR DTA144ES	
Q807	8-729-900-61	TRANSISTOR DTA114ES	
Q808	8-729-900-80	TRANSISTOR DTC114ES	
Q809	8-729-801-84	TRANSISTOR 2SB1013-4	
Q810	8-729-119-76	TRANSISTOR 2SA1175-HFE	
		< RESISTOR >	
R101	1-249-417-11	CARBON 1K 5%	1/4W
R102	1-249-421-11	CARBON 2.2K 5%	1/4W
R103	1-247-887-00	CARBON 220K 5%	1/4W
R104	1-249-423-11	CARBON 3.3K 5%	1/4W
R105	1-247-887-00	CARBON 220K 5%	1/4W
R106	1-249-423-11	CARBON 3.3K 5%	1/4W
R107	1-249-428-11	CARBON 8.2K 5%	1/4W
R108	1-247-864-11	CARBON 24K 5%	1/4W
R109	1-249-414-11	CARBON 560 5%	1/4W
R110	1-249-421-11	CARBON 2.2K 5%	1/4W
R111	1-249-421-11	CARBON 2.2K 5%	1/4W
R112	1-249-432-11	CARBON 18K 5%	1/4W
R113	1-249-425-11	CARBON 4.7K 5%	1/4W
R121	1-249-429-11	CARBON 10K 5%	1/4W
R122	1-249-423-11	CARBON 3.3K 5%	1/4W
R141	1-249-433-11	CARBON 22K 5%	1/4W
R142	1-249-417-11	CARBON 1K 5%	1/4W
R151	1-249-434-11	CARBON 27K 5%	1/4W
R152	1-247-868-11	CARBON 36K 5%	1/4W
R153	1-247-870-11	CARBON 43K 5%	1/4W
R154	1-249-408-11	CARBON 180 5%	1/4W
R161	1-249-432-11	CARBON 18K 5%	1/4W
R162	1-249-421-11	CARBON 2.2K 5%	1/4W
R163	1-247-854-11	CARBON 9.1K 5%	1/4W
R164	1-249-409-11	CARBON 220 5%	1/4W
R165	1-249-432-11	CARBON 18K 5%	1/4W
R201	1-249-417-11	CARBON 1K 5%	1/4W
R202	1-249-421-11	CARBON 2.2K 5%	1/4W
R203	1-247-887-00	CARBON 220K 5%	1/4W
R204	1-249-423-11	CARBON 3.3K 5%	1/4W
R205	1-247-887-00	CARBON 220K 5%	1/4W
R206	1-249-423-11	CARBON 3.3K 5%	1/4W
R207	1-249-428-11	CARBON 8.2K 5%	1/4W
R208	1-247-864-11	CARBON 24K 5%	1/4W
R209	1-249-414-11	CARBON 560 5%	1/4W
R210	1-249-421-11	CARBON 2.2K 5%	1/4W
R211	1-249-421-11	CARBON 2.2K 5%	1/4W
R212	1-249-432-11	CARBON 18K 5%	1/4W
R213	1-249-425-11	CARBON 4.7K 5%	1/4W
R221	1-249-429-11	CARBON 10K 5%	1/4W

SYSTEM CONTROL

Ref.No.	Part No.	Description	Remark			Ref.No.	Part No.	Description	Remark		
R222	1-249-423-11	CARBON	3.3K	5%	1/4W	R705	1-249-419-11	CARBON	1.5K	5%	1/4W
R241	1-249-433-11	CARBON	22K	5%	1/4W	R706	1-249-429-11	CARBON	10K	5%	1/4W
R242	1-249-417-11	CARBON	1K	5%	1/4W	R707	1-249-419-11	CARBON	1.5K	5%	1/4W
R251	1-249-434-11	CARBON	27K	5%	1/4W	R708	1-249-425-11	CARBON	4.7K	5%	1/4W
R252	1-247-868-11	CARBON	36K	5%	1/4W	R709	1-249-409-11	CARBON	220	5%	1/4W
R253	1-247-870-11	CARBON	43K	5%	1/4W	R710	1-249-417-11	CARBON	1K	5%	1/4W
R254	1-249-408-11	CARBON	180	5%	1/4W	R711	1-249-427-11	CARBON	6.8K	5%	1/4W
R261	1-249-432-11	CARBON	18K	5%	1/4W	R712	1-249-427-11	CARBON	6.8K	5%	1/4W
R262	1-249-421-11	CARBON	2.2K	5%	1/4W	R713	1-249-417-11	CARBON	1K	5%	1/4W
R263	1-247-854-11	CARBON	9.1K	5%	1/4W	R714	1-247-838-00	CARBON	2K	5%	1/4W
R264	1-249-409-11	CARBON	220	5%	1/4W	R715	1-249-421-11	CARBON	2.2K	5%	1/4W
R265	1-249-432-11	CARBON	18K	5%	1/4W	R716	1-249-429-11	CARBON	10K	5%	1/4W
R501	1-249-417-11	CARBON	1K	5%	1/4W	R717	1-249-436-11	CARBON	39K	5%	1/4W
R502	1-215-455-00	METAL	27K	1%	1/6W	R718	1-249-433-11	CARBON	22K	5%	1/4W
R503	1-249-429-11	CARBON	10K	5%	1/4W	R719	1-249-441-11	CARBON	100K	5%	1/4W
R521	1-215-455-00	METAL	27K	1%	1/6W	R801	1-249-432-11	CARBON	18K	5%	1/4W
R522	1-249-429-11	CARBON	10K	5%	1/4W	R802	1-249-423-11	CARBON	3.3K	5%	1/4W
R523	1-249-421-11	CARBON	2.2K	5%	1/4W	R803	1-249-435-11	CARBON	33K	5%	1/4W
R524	1-249-433-11	CARBON	22K	5%	1/4W	R804	1-249-435-11	CARBON	33K	5%	1/4W
R525	1-247-854-11	CARBON	9.1K	5%	1/4W	R805	1-247-903-00	CARBON	1M	5%	1/4W
R526	1-247-846-11	CARBON	4.3K	5%	1/4W	R806	1-249-435-11	CARBON	33K	5%	1/4W
R527	1-249-425-11	CARBON	4.7K	5%	1/4W	R807	1-249-435-11	CARBON	33K	5%	1/4W
R528	1-249-425-11	CARBON	4.7K	5%	1/4W	R808	1-249-435-11	CARBON	33K	5%	1/4W
R532	1-249-417-11	CARBON	1K	5%	1/4W	R809	1-249-435-11	CARBON	33K	5%	1/4W
R534	1-247-836-11	CARBON	1.6K	5%	1/4W	R812	1-249-429-11	CARBON	10K	5%	1/4W
R535	1-249-426-11	CARBON	5.6K	5%	1/4W	R813	1-249-435-11	CARBON	33K	5%	1/4W
R541	1-247-850-11	CARBON	6.2K	5%	1/4W	R814	1-249-435-11	CARBON	33K	5%	1/4W
R542	1-247-862-11	CARBON	20K	5%	1/4W	R815	1-249-435-11	CARBON	33K	5%	1/4W
R543	1-249-428-11	CARBON	8.2K	5%	1/4W	R816	1-249-429-11	CARBON	10K	5%	1/4W
R545	1-249-425-11	CARBON	4.7K	5%	1/4W	R817	1-247-862-11	CARBON	20K	5%	1/4W
R546	1-247-838-00	CARBON	2K	5%	1/4W	R818	1-249-433-11	CARBON	22K	5%	1/4W
R551	1-249-441-11	CARBON	100K	5%	1/4W	R819	1-249-430-11	CARBON	12K	5%	1/4W
R552	1-249-429-11	CARBON	10K	5%	1/4W	R820	1-249-433-11	CARBON	22K	5%	1/4W
R553	1-249-441-11	CARBON	100K	5%	1/4W	R821	1-249-433-11	CARBON	22K	5%	1/4W
R554	1-249-428-11	CARBON	8.2K	5%	1/4W	R822	1-249-405-11	CARBON	100	5%	1/4W
R555	1-249-441-11	CARBON	100K	5%	1/4W	R823	1-249-429-11	CARBON	10K	5%	1/4W
R556	1-249-423-11	CARBON	3.3K	5%	1/4W	R824	1-249-413-11	CARBON	470	5%	1/4W
R557	1-249-441-11	CARBON	100K	5%	1/4W	R825	1-249-403-11	CARBON	68	5%	1/4W
R558	1-249-429-11	CARBON	10K	5%	1/4W	R826	1-249-422-11	CARBON	2.7K	5%	1/4W
R559	1-249-429-11	CARBON	10K	5%	1/4W	R827	1-249-422-11	CARBON	2.7K	5%	1/4W
R560	1-249-417-11	CARBON	1K	5%	1/4W	R828	1-249-422-11	CARBON	2.7K	5%	1/4W
R561	1-249-431-11	CARBON	15K	5%	1/4W	R830	1-249-405-11	CARBON	100	5%	1/4W
R562	1-249-436-11	CARBON	39K	5%	1/4W	R831	1-249-405-11	CARBON	100	5%	1/4W
R601	1-249-429-11	CARBON	10K	5%	1/4W	R832	1-249-405-11	CARBON	100	5%	1/4W
R602	1-249-435-11	CARBON	33K	5%	1/4W	R833	1-249-405-11	CARBON	100	5%	1/4W
R701	1-249-425-11	CARBON	4.7K	5%	1/4W	R901	1-249-420-11	CARBON	1.8K	5%	1/4W
R702	1-249-420-11	CARBON	1.8K	5%	1/4W	R902	1-249-423-11	CARBON	3.3K	5%	1/4W
R703	1-249-426-11	CARBON	5.6K	5%	1/4W	R903	1-249-426-11	CARBON	5.6K	5%	1/4W
R704	1-249-427-11	CARBON	6.8K	5%	1/4W	R904	1-249-429-11	CARBON	10K	5%	1/4W

SYSTEM CONTROL

Ref.No.	Part No.	Description	Remark
R905	1-249-435-11	CARBON 33K 5%	1/4W
R906	1-249-420-11	CARBON 1.8K 5%	1/4W
R907	1-249-423-11	CARBON 3.3K 5%	1/4W
R908	1-249-426-11	CARBON 5.6K 5%	1/4W
R909	1-249-429-11	CARBON 10K 5%	1/4W
R910	1-249-429-11	CARBON 10K 5%	1/4W

< VARIABLE RESISTOR >

RV121	1-238-600-11	RES, ADJ, CARBON 10K (REC GAIN)
RV221	1-238-600-11	RES, ADJ, CARBON 10K (REC GAIN)
RV501	1-241-820-11	RES, VAR, CARBON 50K/50K (REC LEVEL)
RV502	1-241-821-11	RES, VAR, CARBON 50K/50K (BALANCE)
RV503	1-241-822-11	RES, VAR, CARBON 5K (BIAS)

< SWITCH >

S501	1-692-063-11	SWITCH, ROTARY (DOLBY NR)
S601	1-554-118-00	SWITCH, PUSH (1 KEY) (POWER)
S602	1-571-520-11	SWITCH, SLIDE (DIRECTION)
S901	1-554-303-21	SWITCH, TACTILE (PAUSE)
S902	1-554-303-21	SWITCH, TACTILE (▷)

S904	1-554-303-21	SWITCH, TACTILE (◁)
S905	1-554-303-21	SWITCH, TACTILE (REC MUTE)
S906	1-554-303-21	SWITCH, TACTILE (RESET)
S907	1-554-303-21	SWITCH, TACTILE (MEMORY)
S908	1-554-303-21	SWITCH, TACTILE (■)

S909	1-554-303-21	SWITCH, TACTILE (◁◁)
S910	1-554-303-21	SWITCH, TACTILE (▷▷)
S911	1-554-303-21	SWITCH, TACTILE (REC)

< CONNECTOR >

* TP801 1-564-505-11 PLUG, CONNECTOR 2P

< CRYSTAL >

X801 1-577-358-21 VIBRATOR, CERAMIC

MISCELLANEOUS

1	1-575-781-11	WIRE, FLAT TYPE (9 CORE)
△6	1-555-795-00	CORD, POWER, EULO PLUG (AEP)
△6	1-558-945-11	CORD, POWER (POLAR. SPT-1) (US, Canadian)
103	1-638-983-11	PC BOARD, MOTOR FLEXIBLE
△F701	1-532-285-00	FUSE, TIME-LAG (AEP)
△F701	1-532-741-11	FUSE, GLASS TUBE (US, Canadian)
△F702	1-532-285-00	FUSE, TIME-LAG (AEP)
△F702	1-532-741-11	FUSE, GLASS TUBE (US, Canadian)
M1	X-3359-417-1	MOTOR ASSY, CAPSTAN
M2	X-3363-501-1	MOTOR ASSY, REEL

Ref.No.	Part No.	Description	Remark
△T901	1-450-750-11	TRANSFORMER, POWER (AEP)	
△T901	1-450-751-11	TRANSFORMER, POWER (US, Canadian)	

ACCESSORIES & PACKING MATERIALS

	1-558-271-11	CORD, CONNECTION
*	3-350-830-01	CUSHION
*	3-376-443-81	INDIVIDUAL CARTON
	3-755-327-11	MANUAL, INSTRUCTION (Canadian, AEP) (ENGLISH/FRENCH/SPANISH/PORTUGUESE)
	3-755-327-21	MANUAL, INSTRUCTION (US, Canadian) (ENGLISH)
	3-755-327-41	MANUAL, INSTRUCTION (AEP) (GERMAN/DUTCH/SWEDISH/ITALIAN)

HARDWARE LIST

#1	7-682-548-09	SCREW +BVTT 3X8 (S)
#2	7-682-547-04	SCREW +BVTT 3X6 (S)
#3	7-621-849-00	SCREW (BV/RING)
#4	7-621-773-95	SCREW +BVTT 2.6X6 (S)
#5	7-685-134-19	SCREW (+ PTPWH) (2.6X8)
#6	7-621-775-00	SCREW +B 2.6X3
#7	7-627-556-08	SCREW +P 2.6X2.8

Note:
The components identified by mark **△** or dotted line with mark **△** are critical for safety. Replace only with part number specified.

Note:
Les composants identifiés par une marque **△** sont critiques pour la sécurité. Ne les remplacer que par une pièce portant le numéro spécifié.