

TC-RX420

SERVICE MANUAL

US Model
Canadian Model



Dolby noise reduction manufactured under license from Dolby Laboratories Licensing Corporation. "DOLBY" and the double-D symbol  are trademarks of Dolby Laboratories Licensing Corporation.

SPECIFICATIONS

Recording system 4-track 2-channel stereo
Fast winding Approx. 90 sec. (with C-60 cassette)
Bias AC Bias
Signal-to-noise ratio (NAB, at peak level)

DOLBY NR button Cassette	OFF	B-TYPE ON	C-TYPE ON
	Type IV (Sony METAL-ES)	58dB	65dB
Type II (Sony UX-S)	57dB	64dB	70dB
Type I (Sony HF-S)	54dB	61dB	67dB

Total harmonic distortion 1.0 % (with Sony METAL-ES cassettes)
Frequency response (DOLBY NR OFF)

Type IV cassette (Sony METAL-ES)	20–16,000 Hz (± 3 dB) 30–15,000 Hz (± 3 dB, 0VU recording)
Type II cassette (Sony UX-S)	20–16,000 Hz (± 3 dB) 30–15,000 Hz
Type I cassette (Sony HF-S)	25–15,000 Hz (± 3 dB) 30–14,000 Hz

Wow and flutter 0.09% WRMS (NAB)

Inputs

Microphone inputs (phone jacks)	Sensitivity	0.25 mV (-70 dB)
	For a low-impedance microphone	
Line inputs (phono jacks)	Sensitivity	77.5 mV (-20 dB)
	Input impedance	50k ohms

Model Name Using Similar Mechanism	TC-WR620
Tape Transport Mechanism Type	TCM-190RB12

Outputs

Line outputs (phono jacks)	Output level	0.44 V (-5 dB) at a load impedance of 47k ohms
	Load impedance	over 10k ohms
Headphones output (stereo phone jack)	Output level	-28 dB at a load impedance of 8 ohms

General

Power requirements

120 V AC, 60 Hz

Power consumption

22 W

Dimensions

Approx. 430 × 123 × 295 mm (w/h/d)
(17 × 4 $\frac{7}{8}$ × 11 $\frac{5}{8}$ inches)

including projecting parts and controls

Weight

Approx. 4.0 kg (8 lbs 13 oz)

Supplied accessory

Connecting cord (2)

Design and specifications are subject to change without notice.

STEREO CASSETTE DECK
SONY®

MODEL IDENTIFICATION

—Specification Label—

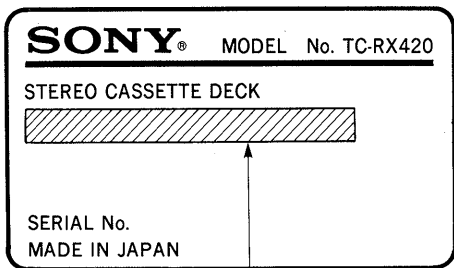

US, Canadian MODEL: AC 120 60Hz 22W

SAFETY CHECK-OUT

After correcting the original service problem, perform the following safety check before releasing the set to the customer:

Check the antenna terminals, metal trim, “metallized” knobs, screws, and all other exposed metal parts for AC leakage. Check leakage as described below.

LEAKAGE TEST



The AC leakage from any exposed metal part to earth ground and from all exposed metal parts to any exposed metal part having a return to chassis, must not exceed 0.5 mA (500 microamperes). Leakage current can be measured by any one of three methods.

1. A commercial leakage tester, such as the Simpson 229 or RCA WT-540A. Follow the manufacturers' instructions to use these instruments.

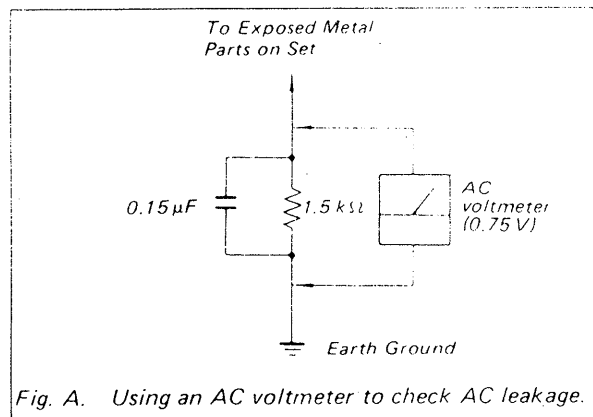
2. A battery-operated AC milliammeter. The Data Precision 245 digital multimeter is suitable for this job.
3. Measuring the voltage drop across a resistor by means of a VOM or battery-operated AC voltmeter. The “limit” indication is 0.75 V, so analog meters must have an accurate low-voltage scale. The Simpson 250 and Sanwa SH-63Trd are examples of a passive VOM that is suitable. Nearly all battery operated digital multimeters that have a 2V AC range are suitable. (See Fig. A)



SAFETY-RELATED COMPONENT WARNING!!

COMPONENTS IDENTIFIED BY MARK  OR DOTTED LINE WITH MARK  ON THE SCHEMATIC DIAGRAMS AND IN THE PARTS LIST ARE CRITICAL TO SAFE OPERATION. REPLACE THESE COMPONENTS WITH SONY PARTS WHOSE PART NUMBERS APPEAR AS SHOWN IN THIS MANUAL OR IN SUPPLEMENTS PUBLISHED BY SONY.

ATTENTION AU COMPOSANT AYANT RAPPORT À LA SÉCURITÉ!

LES COMPOSANTS IDENTIFIÉS PAR UNE MARQUE  SUR LES DIAGRAMMES SCHÉMATIQUES ET LA LISTE DES PIÈCES SONT CRITIQUES POUR LA SÉCURITÉ DE FONCTIONNEMENT. NE REMPLACER CES COMPOSANTS QUE PAR DES PIÈCES SONY DONT LES NUMÉROS SONT DONNÉS DANS CE MANUEL OU DANS LES SUPPLÉMENTS PUBLIÉS PAR SONY.

SECTION 1 GENERAL

Identification of Front Panel Parts

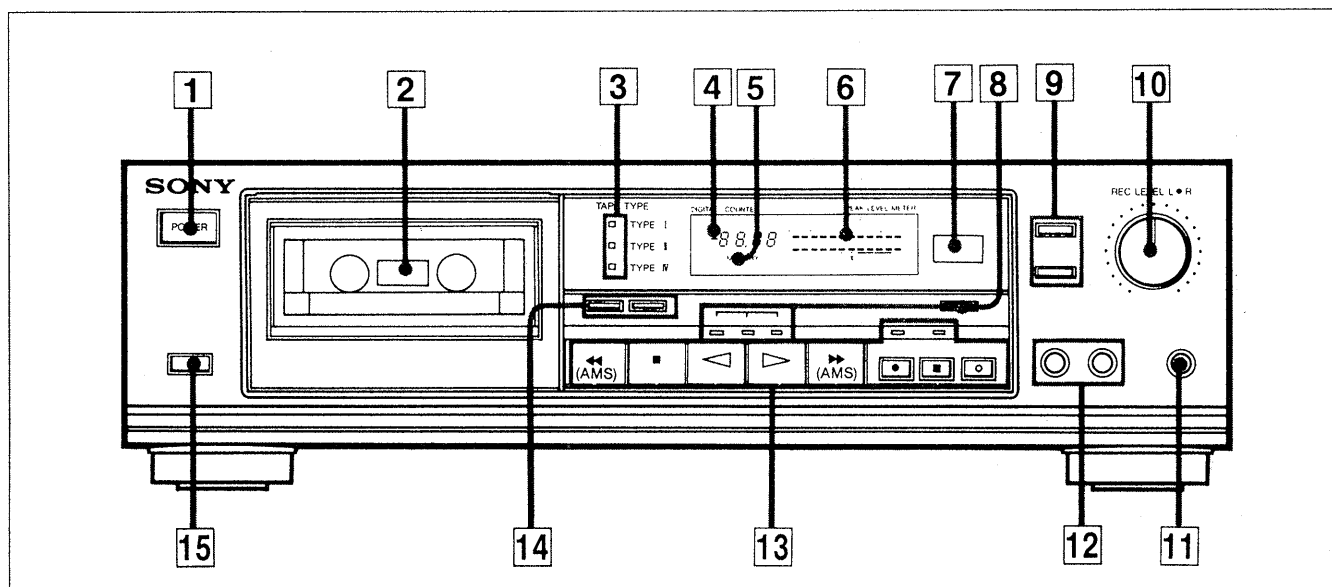

- | | |
|---|--|
| <p>1 POWER switch</p> <p>2 Cassette holder</p> <p>3 TAPE TYPE indicators</p> <p>4 Digital Counter</p> <p>5 MEMORY indicator</p> <p>6 PEAK LEVEL METER</p> <p>7 Remote control sensor
You can remotely control this cassette deck with:
— A remote commander that has an mark and comes with a Sony amplifier or receiver and which can be used to control a cassette deck.
— An optional Sony remote commander that has an mark.</p> <p>8 DIRECTION MODE button and indicators</p> <p>9 DOLBY NR (Dolby noise reduction) buttons</p> | <p>10 REC LEVEL (recording level) control</p> <p>11 HEADPHONES jack (stereo phone jack)</p> <p>12 MICROPHONE jacks (phone jacks) (left and right)</p> <p>13 Tape operation buttons and direction mode, REC and PAUSE indicators
 (leftward fast winding) (AMS) button
 (stop) button
 (forward play) button
 (reverse play) button
 (rightward fast winding) (AMS) button
 REC (record) button
 (pause) button
 REC MUTE (record muting) button</p> <p>14 COUNTER RESET and MEMORY buttons</p> <p>15 EJECT button</p> |
|---|--|

SECTION 2 ADJUSTMENTS

2-1. MECHANICAL ADJUSTMENTS

PRECAUTION

1. Clean the following parts with a denatured-alcohol-moistened swab :

record/playback head	pinch roller
erase head	rubber belts
capstan	idler
2. Demagnetize the record/playback head with a head demagnetizer.
3. Do not use a magnetized screwdriver for the adjustment.
4. After the adjustments, apply suitable locking compound to the parts adjusted.
5. The adjustments should be performed with the rated power supply voltage unless otherwise noted.
6. Switch position

DOLBY NR	: OFF
B/C	: B
DIRECTION MODE	: ⇌

Torque Measurement

Torque	Torque meter	Meter reading
FWD	CQ-102C	30 to 65g·cm (0.417 to 0.903 oz·inch)
FWD Back tension	CQ-102C	1 to 6g·cm (0.014 to 0.083 oz·inch)
REV	CQ-102RC	30 to 65g·cm (0.417 to 0.903 oz·inch)
REV Back Tension	CQ-102RC	1 to 6g·cm (0.014 to 0.083 oz·inch)
FF, REW	CQ-201B	70 to 120g·cm (0.97 to 1.67 oz·inch)

2-2. ELECTRICAL ADJUSTMENTS

Note : The adjustment should be performed in the order given in the service manual.

The adjustment should be performed for both L-CH and R-CH.

- Switches and controls should be set as follows unless otherwise specified.

DOLBY NR switch	: OFF
DIRECTION MODE switch:	⇌
TIMER switch	: OFF
TAPE SELECT switch	: According to the tape type.

Tape	TAPE Switch
CS-17	TYPE I
CS-26	TYPE II
CS-42	TYPE IV

- **Standard Record :**

Deliver the standard input signal level to the input jack and set the REC LEVEL control to obtain the standard output signal level.

—Record Mode—

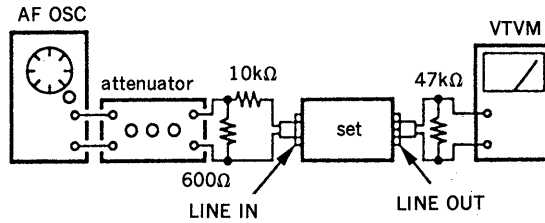

Standard Input Level

	LINE IN
source impedance	10kΩ
input level	0.25V (-10dB)

Standard Output Level

	LINE OUT
load impedance	47kΩ
output signal level	0.44V (-5dB)

Test Tape

Tape	Signal	Use for
P-4-A100	10kHz, -10dB	Azimuth Adjustment
P-4-L300	315Hz, 0dB	PB LEVEL Adjustment
WS-48B	3Hz, 0dB	Tape Speed Adjustment

Record/Playback Head Azimuth Adjustment Procedure :

1. Mode : FWD playback

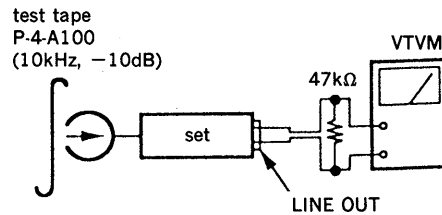

2. Turn the adjustment screw for the maximum output levels. If these levels do not match, turn the adjustment screw until both of output levels match together within 1dB.

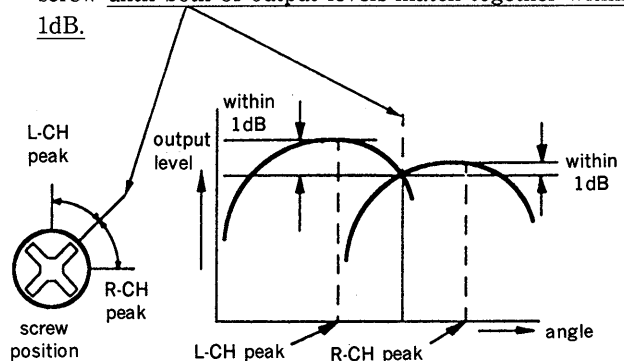

3. Phase Check
Mode : playback

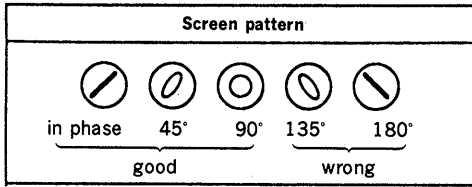
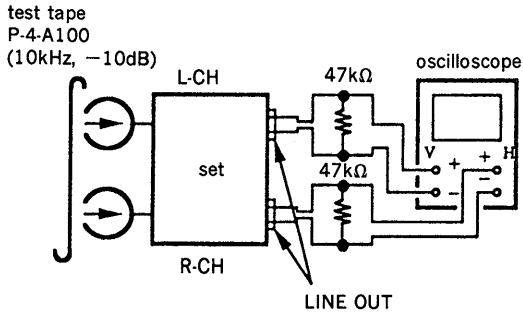

4. Set in the REV mode and repeat the step 1-3.
5. After the adjustment, lock the screws with locking compound.

Adjustment Location : —Record/Playback head—

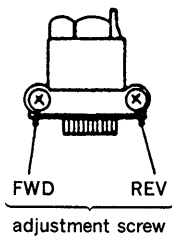

Tape Speed Adjustment

Procedure :
Mode : FWD playback

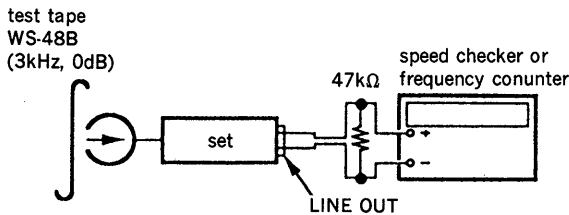

Specifications :

SPEED CHECK	FREQUENCY COUNTER
-0.5+0.5%	2995-3.015Hz

Adjust RV71 so that the frequency difference between the beginning and the end of the tape should be contented within 1.2% (35Hz)

Adjustment Location : MD board

Playback Level Adjustment

Procedure :
Mode : playback

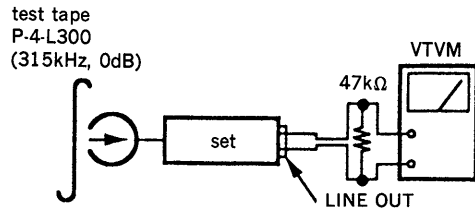

Adjust RV11 (L-CH), RV21 (R-CH) so that the reading on VTVM meets the specification below.

Specification :

LINE OUT level : $-5 \pm 0.5\text{dB}$ (0.41-0.46V)

Level difference between channels : less than 0.5dB

Check that the LINE OUT level does not change in playback mode while changing the mode from playback to stop several times.

Adjustment Location : MD board

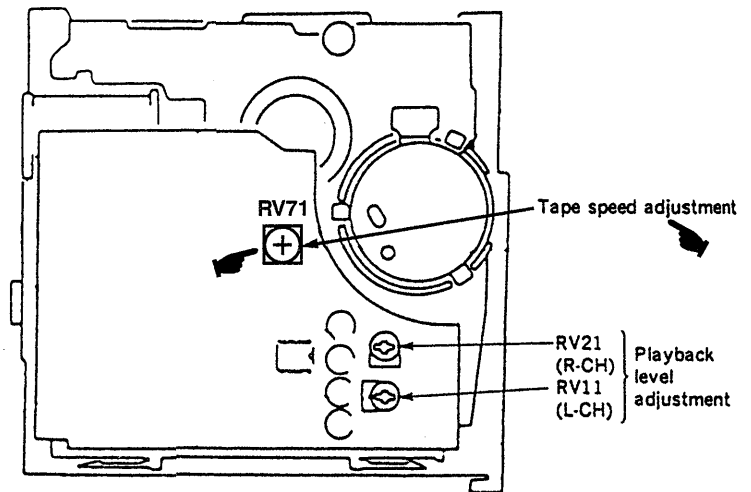

Bias Consumption Current Adjustment

Note : Perform this adjustment before Record Bias Adjustment only when replacing head, IC51, or step-up transformers (T51, T71).

Setting :
REC LEVEL control : standard record
(See page 4).

Procedure :

1. Set RV42 and RV62 to mechanical center.
2. Set blank tape (CS-421) and record on no-signal conditions.
3. Adjust T51 (L-CH), T71 (R-CH) so that the voltage between pin ③-⑤ (L-CH), pin ③-① (R-CH) of TP91 is minimum. (Less than 160mV)
4. Perform Record Bias Adjustment and Record Level Adjustment.

Record Bias Adjustment

Setting :

REC LEVEL control : standard record (See page 4.)

Procedure :

1. Mode : record

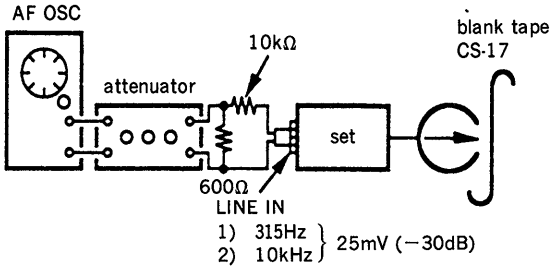

2. Mode : playback

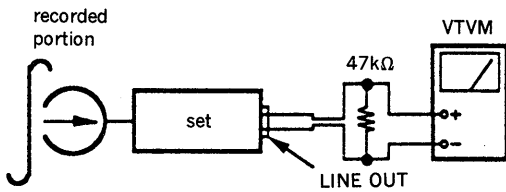

Confirm that the 10kHz playback output is 0 ± 0.5 dB relative to the 315Hz output. If necessary, adjust RV42 (L-CH), RV62 (R-CH) and repeat the steps given above.

Adjustment Location : HX PRO board

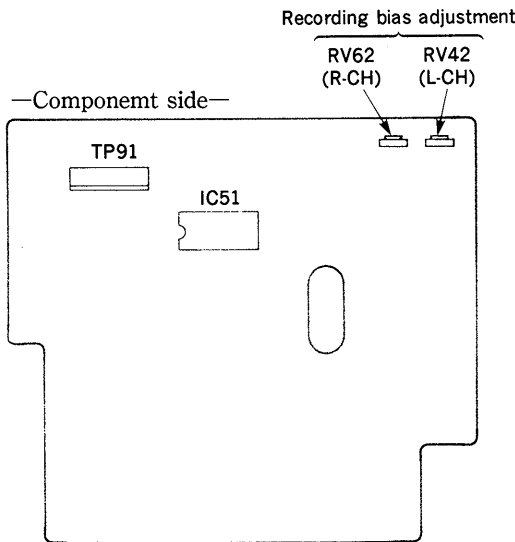

Note : Blank tape used in Record Bias Adjustment and Record Level Adjustment has been changed from CS-17 to CS-122.

New type and old type blank tapes are shown in the following list.

Blank Tape

Type	Old type tape	New type tape	New type tape part No.
TYPE I	CS-17	CS-122	8-892-331-56
TYPE II	CS-26	CS-222	8-92-331-55
TYPE IV	CS-42	CS-412	8-892-324-39

Record Level Adjustment

Setting :

REC LEVEL control : standard record (See page 4.)

Procedure :

1. Mode : record

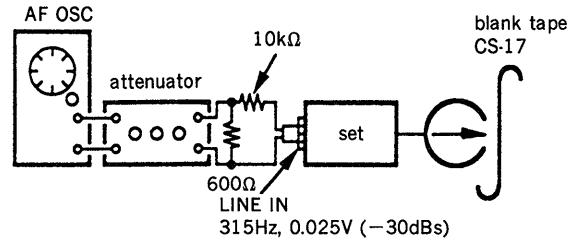

2. Mode : playback

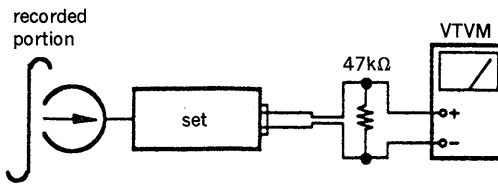

3. Play back the signal recorded in step 1.
Confirm that the signal level is within the specification below. If necessary, adjust RV101 (L-CH), RV201 (R-CH) and repeat the step 1-3.

Specification : LINE OUT level : $-25\text{dB} \pm 0.5\text{dBs}$
(0.041—0.046V)

Adjustment Location : MAIN board

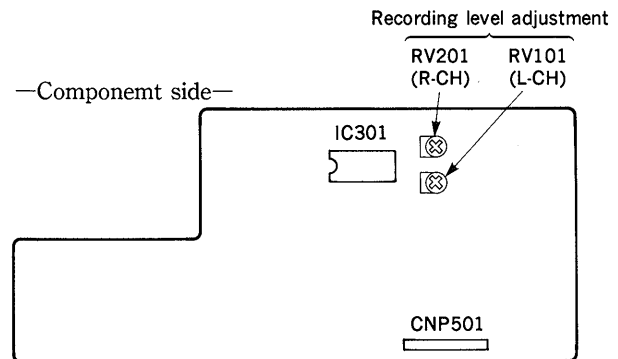

SECTION 3
DIAGRAMS

3-1. SEMICONDUCTOR LEAD LAYOUTS

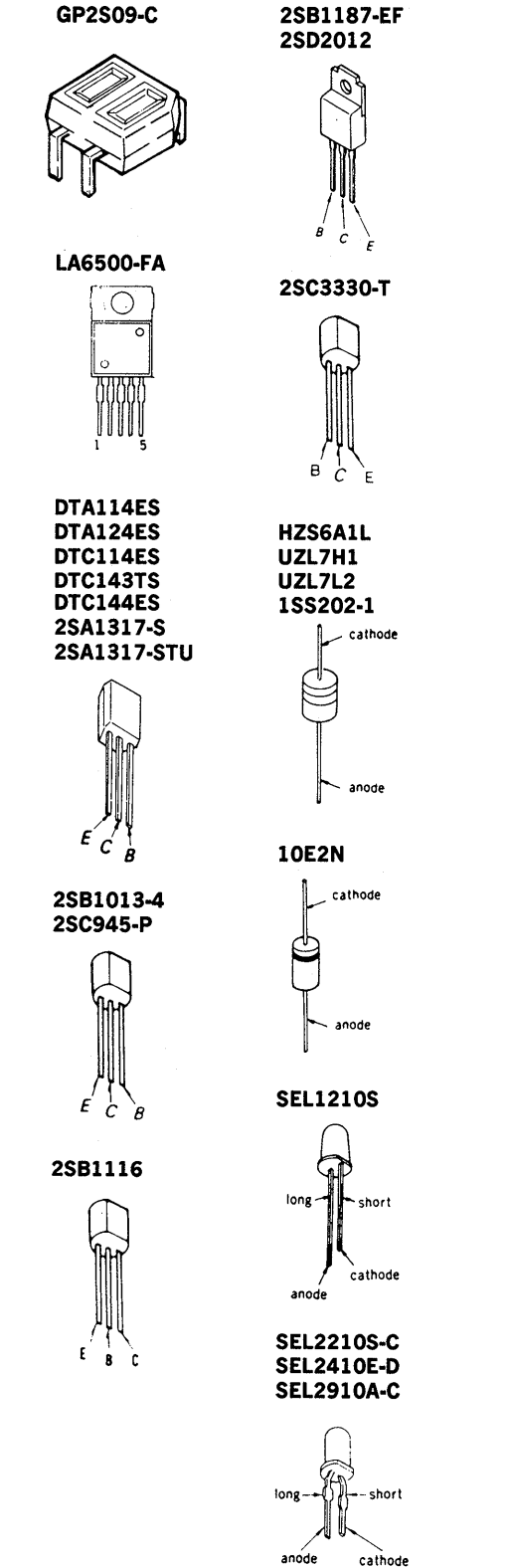

• Semiconductor Location

Ref. No.	Location	Ref. No.	Location
D31	G-5	Q502	I-14
D101	F-10	Q503	E-16
D201	E-10	Q504	E-16
D301	E-19	Q505	E-13
D302	F-11	Q506	E-13
D303	F-11	Q507	E-13
D501	J-16	Q508	F-20
D502	J-16	Q509	F-20
D503	J-19	Q510	F-20
D504	J-18	Q511	E-12
D505	J-19	Q512	E-12
D506	I-21	Q513	E-11
D507	I-21	Q514	I-20
D508	I-21	Q701	D-13
D509	F-12	Q702	E-13
D510	F-20	Q703	D-14
D511	I-20	Q704	F-15
D512	I-21	Q705	E-15
D513	I-21	Q706	E-15
D514	I-21	Q707	E-16
D701	D-16	Q708	E-16
D702	D-16	Q709	E-18
D703	D-16		
D704	D-16		
D705	D-16		
D706	D-16		
D707	D-14		
D708	D-14		
D709	E-15		
D710	D-16		
D711	E-16		
D712	E-16		
D713	F-17		
D714	E-15		
IC31	H-3		
IC51	B-5		
IC81	K-4		
IC301	C-10		
IC302	B-13		
IC303	B-15		
IC304	B-16		
IC305	F-10		
IC306	F-10		
IC307	H-8		
IC501	I-17		
IC502	I-15		
IC503	E-14		
IC701	D-14		
Q51	F-5		
Q52	F-4		
Q53	G-5		
Q71	F-4		
Q101	F-9		
Q102	D-11		
Q103	C-13		
Q201	E-9		
Q202	B-11		
Q203	B-13		
Q301	E-19		
Q302	B-15		
Q501	I-20		

Note:
 ○ — : parts extracted from the component side.
 □ — : indicates side identified with part number.

3-2. PRINTED WIRING BOARDS

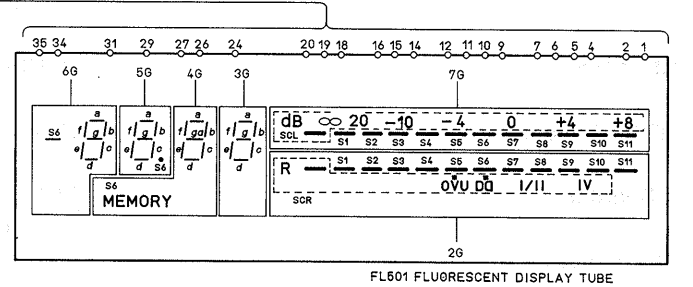
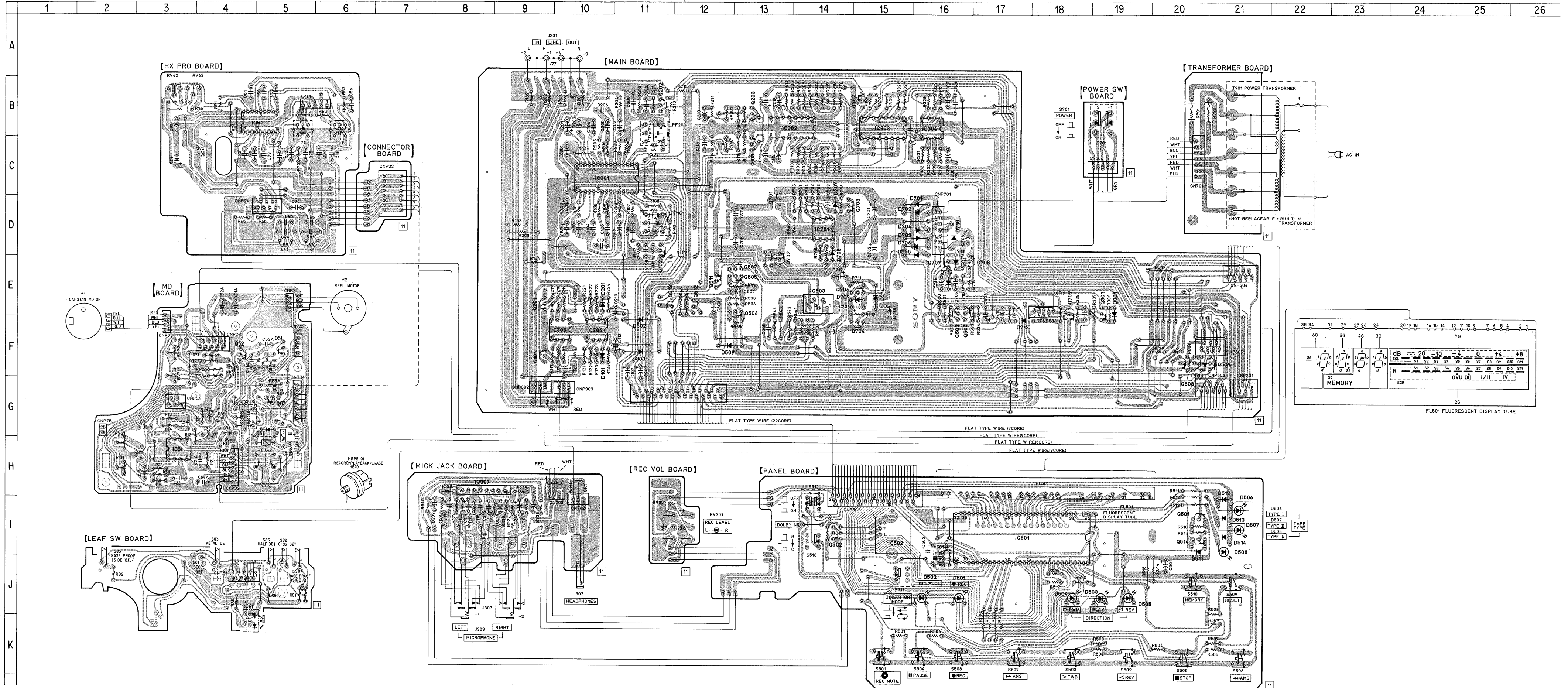

SECTION 4 EXPLODED VIEWS

NOTE:

- The mechanical parts with no reference number in the exploded views are not supplied.
- The construction parts of an assembled part are indicated with a collation number in the remark column.
- Items marked "★" are not stocked since they are seldom required for routine service. Some delay should be anticipated when ordering these items.

- Due to standardization, parts with part number suffix -XX and -X may be different from the parts specified in the components used on the set.
- Color Indication of Appearance Parts
Example:
(RED) ... KNOB, BALANCE (WHITE)
↑ Cabinet's Color ↑ Parts' Color

The components identified by mark or dotted line with mark are critical for safety. Replace only with part number specified.

Les composants identifiés par une marque sont critiques pour la sécurité. Ne les remplacer que par une pièce portant le numéro spécifié.

4-1. CABINET SECTION

- A: PANEL BOARD
- B: TRANSFORMER BOARD
- C: MIC JACK BOARD
- D: REC VOL BOARD

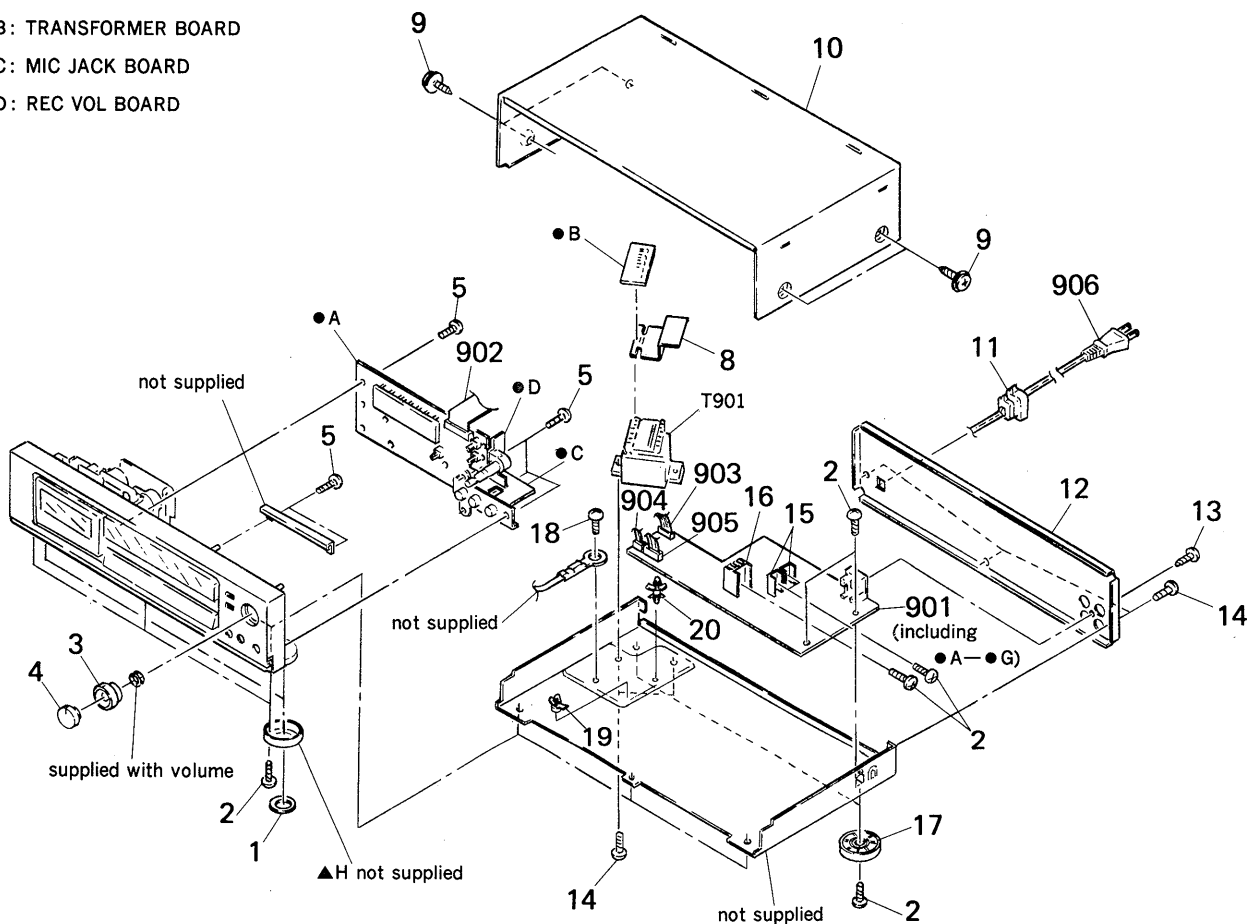

No.	Part No.	Description	Remarks	No.	Part No.	Description	Remarks
1	4-923-836-11	CUSHION		16	*4-363-147-00	HEAT SINK, H.PIN	
2	7-682-548-04	SCREW +BVTT 3X8 (S)		17	X-4885-950-1	FOOT ASSY	
3	3-332-589-01	KNOB (REC VOL-LEFT)		18	7-682-547-04	SCREW +BVTT 3X6 (S)	
4	3-332-590-01	KNOB (REC VOL-RIGHT)		19	3-350-847-11	HOLDER, PCB	
5	4-928-635-01	SCREW, +BV (2.6X8) TAPPING		20	3-350-857-01	HOLDER (A), PCB	
8	*3-337-136-11	COVER, TRANSFORMER SAFETY		901	*A-2006-270-A	MOUNTED PCB, AUDIO	
9	3-704-366-01	SCREW (CASE) (M3X8)		902	1-575-903-11	WIRE, FLAT TYPE (29 CORE)	
10	3-332-578-61	CASE		903	1-575-216-11	WIRE, FLAT TYPE (9 CORE)	
11	3-703-571-00	BUSHING (S) (4516), CORD		904	1-575-220-11	WIRE, FLAT TYPE (5 CORE)	
12	*3-350-854-01	PANEL, BACK		905	*1-574-727-11	WIRE, FLAT TYPE (9 CORE)	
13	7-621-849-00	SCREW, TAPPING		906	▲.1-551-506-XX	CORD, POWER	
14	7-682-548-09	SCREW +BVTT 3X8 (S)		T901	▲.1-449-596-11	TRANSFORMER, POWER	
15	*4-880-403-11	HEAT SINK					

4-2. FRONT PANEL SECTION

- E: HX PRO BOARD
- F: CONNECTOR BOARD
- G: POWER SWITCH BOARD

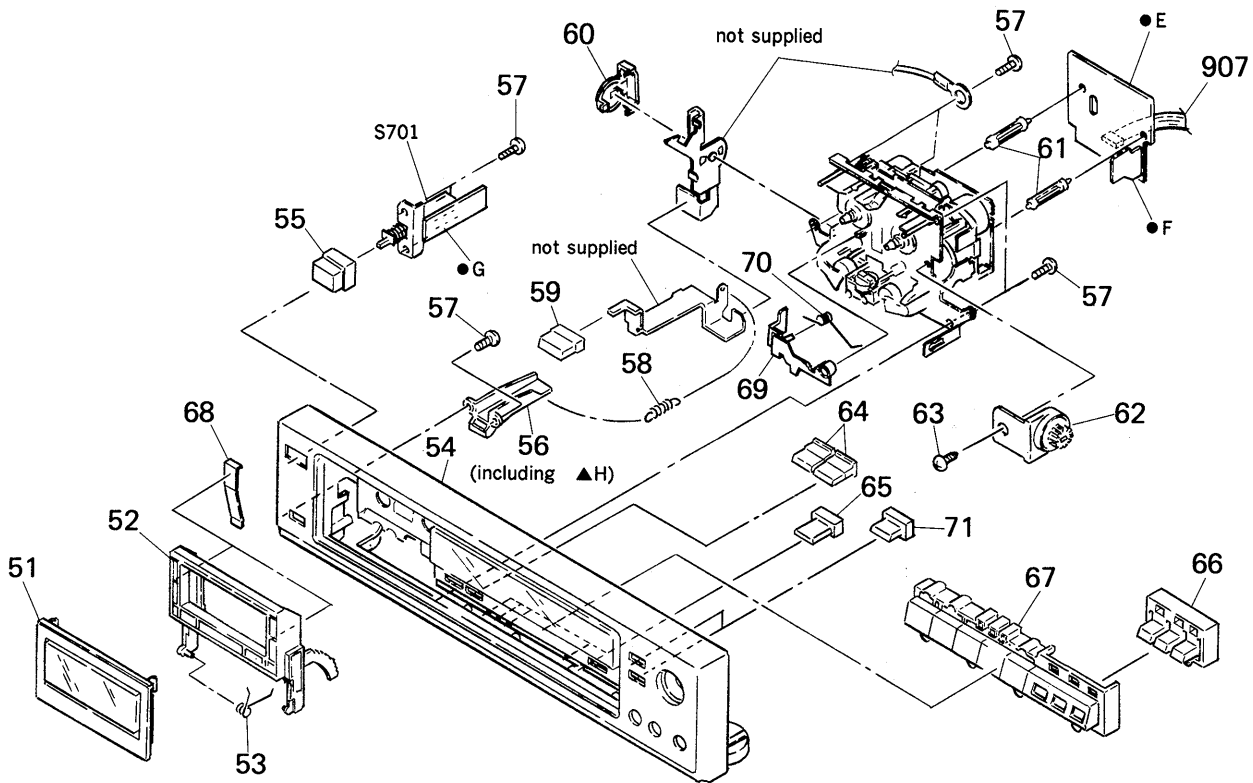

No.	Part No.	Description	Remarks	No.	Part No.	Description	Remarks
51	X-3332-564-1	LID ASSY, CASSETTE		63	7-621-773-95	SCREW +BVTT 2.6X6 (S)	
52	X-3340-194-1	HOLDER (L) ASSY, CASSETTE		64	3-350-812-01	BUTTON (COUNTER)	
53	3-354-959-01	SPRING (LOADING L), TORSION		65	3-350-810-01	BUTTON	
54	X-3332-565-1	PANEL ASSY, FRONT		66	3-350-813-11	BUTTON (B)	
55	3-354-912-01	KNOB, POWER		67	3-350-819-11	BUTTON (A)	
56	*3-349-017-01	RETAINER, SLIDER		68	3-308-823-11	SPRING	
57	4-928-635-01	SCREW, +BV (2.6X8) TAPPING		69	3-354-955-01	LEVER (EJ SAFTY LEVER L)	
58	3-662-752-21	SPRING, TENSION		70	3-354-961-01	SPRING (EJ SAFTY SPRING L)	
59	3-343-698-21	BUTTON (EJECT)		71	3-350-809-01	BUTTON	
60	3-354-957-01	JOINT (LOCK LEVER)		907	1-575-221-11	WIRE, FLAT TYPE (7 CORE)	
61	*3-682-419-21	HOLDER, P.C.B		S701	1-570-103-21	SWITCH, PUSH (1 KEY)(POWER)	
62	3-354-963-01	DAMPER					

4-3. MECHANISM SECTION (1)
(TCM-190RB12)

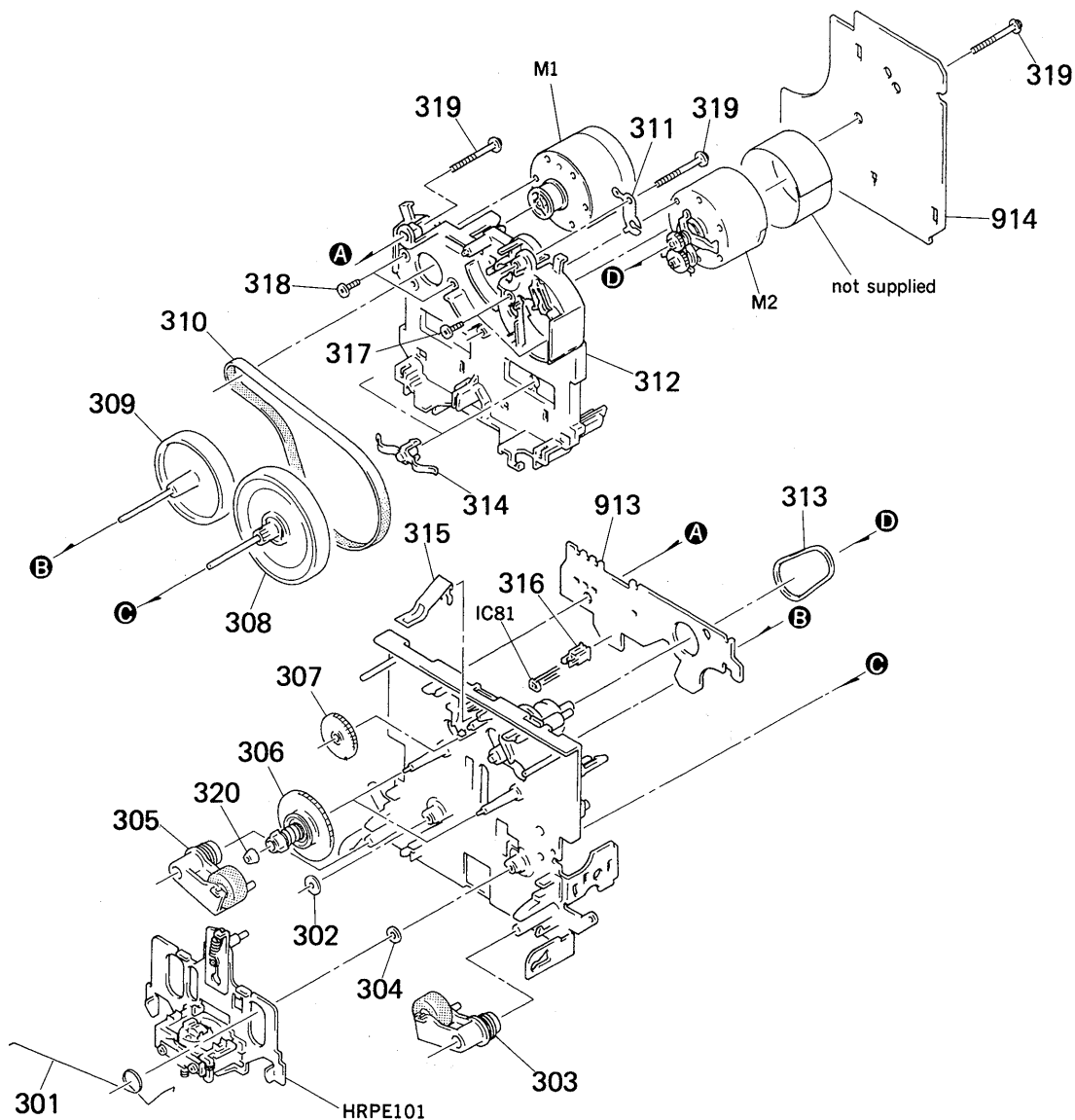

No.	Part No.	Description	Remarks	No.	Part No.	Description	Remarks
301	3-359-455-01	SPRING, TORSION		314	3-575-321-00	RETAINER, THRUST, CAPSTAN	
302	3-356-714-01	WASHER		315	3-359-430-01	SPRING (CASSETTE RETAINER), LEAF	
303	X-3359-408-1	LEVER (PINCH LEVER FWD) ASSY		316	3-343-419-01	HOLDER (S SENSER A)	
304	3-356-713-01	WASHER		317	7-627-556-08	SCREW +P 2.6X2.8	
305	X-3359-409-1	LEVER (PINCH LEVER REV) ASSY		318	7-621-775-00	SCREW +B 2.6X3	
306	X-3359-404-1	TABLE ASSY, REEL		319	3-359-414-01	SCREW (+PTPWH 2X23)	
307	3-359-424-01	GEAR (REV GEAR)		320	3-356-618-01	CAP (REEL)	
308	X-3359-406-1	FLYWHEEL (FWD) COMPLETE ASSY		913	*1-634-841-11	PC BOARD, LEAF SW	
309	X-3359-410-1	FLYWHEEL (REV) ASSY		914	*1-634-842-11	PC BOARD, MD	
310	3-359-417-01	BELT (FLAT), CAPSTAN		HRPE101	A-2003-477-A	BASE ASSY, HEAD	
311	3-359-450-01	PLATE, GROUND		IC81	8-719-939-23	IC GP2S09-C	
312	*3-359-436-01	BASE (THRUST RETAINER), FITTING		M1	X-3359-417-1	MOTOR ASSY, CAPSTAN	
313	3-359-466-01	BELT (FR), SQUARE		M2	A-2003-474-A	MOTOR (REEL MOTOR) ASSY	

4-4. MECHANISM SECTION (2)
(TCM-190RB12)

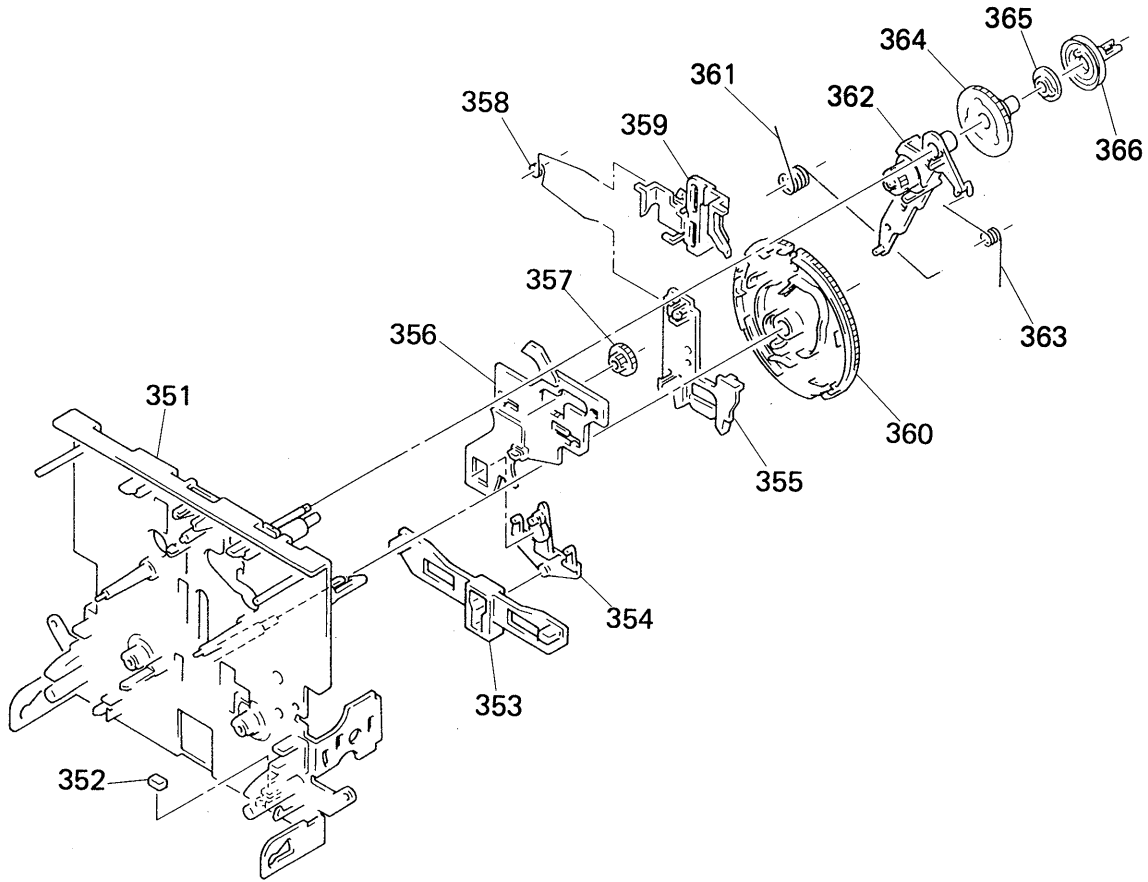

No.	Part No.	Description	Remarks	No.	Part No.	Description	Remarks
351	X-3359-415-1	CHASSIS ASSY, MECHANICAL		359	3-359-429-01	SLIDER (BRAKE PLATE)	
352	*3-359-469-01	SPACER		360	3-359-420-01	GEAR (CAM GEAR)	
353	*3-359-425-01	SLIDER (REVERSE SLIDER)		361	3-359-456-01	SPRING (TRIGGER SPRING), TORSION	
354	3-359-426-01	LEVER (REVERSE LEVER)		362	X-3359-405-1	LEVER (FR ARM) ASSY	
355	*3-359-427-01	SLIDER (LEVERSE SLIDER)		363	3-359-453-01	SPRING (FR ARM), TORSION	
356	*3-359-415-01	SLIDER (TRIGGER SLIDER)		364	3-359-419-01	GEAR (FR GEAR)	
357	3-359-448-01	GEAR (TRIGGER)		365	3-359-421-01	CLUTCH (REEL DISK)	
358	3-359-454-01	SPRING, TORSION		366	3-359-418-01	PULLEY (FR PULLEY)	

SECTION 5 ELECTRICAL PARTS LIST

NOTE:

- Due to standardization, replacements in the parts list may be different from the parts specified in the diagrams or the components used on the set.
- Items marked "★" are not stocked since they are seldom required for routine service. Some delay should be anticipated when ordering these items.
- If there are two or more same circuits in a set such as a stereophonic machine, only typical circuit parts may be indicated and capacitors and resistors in other same circuits may be omitted.

CAPACITORS:

MF: μ F, PF: μ μ F.

RESISTORS

- All resistors are in ohms.
- F: nonflammable

COILS

- MMH: mH, UH: μ H

SEMICONDUCTORS

In each case, U: μ , for example:

UA...: μ A..., UPA...: μ PA...,

UPC...: μ PC, UPD...: μ PD...

The components identified by mark Δ or dotted line with mark Δ are critical for safety. Replace only with part number specified.

Les composants identifiés par une marque Δ sont critiques pour la sécurité. Ne les remplacer que par une pièce portant le numéro spécifié.

Ref.No.	Part No.	Description	Ref.No.	Part No.	Description
901	*A-2006-270-A	MOUNTED PCB, AUDIO	C76	1-130-472-00	MYLAR 0.0012MF 5% 50V
902	1-575-903-11	WIRE, FLAT TYPE (29 CORE)	C92	1-124-478-11	ELECT 100MF 20% 25V
903	1-575-216-11	WIRE, FLAT TYPE (9 CORE)	C93	1-124-477-11	ELECT 47MF 20% 25V
904	1-575-220-11	WIRE, FLAT TYPE (5 CORE)	C94	1-107-046-00	MICA 4.7PF 0.5PF 500V
905	*1-574-727-11	WIRE, FLAT TYPE (9 CORE)	C101	1-124-927-11	ELECT 4.7MF 20% 50V
906	Δ 1-551-506-XX	CORD, POWER	C102	1-124-927-11	ELECT 4.7MF 20% 50V
907	1-575-221-11	WIRE, FLAT TYPE (7 CORE)	C103	1-136-171-00	FILM 0.33MF 5% 50V
913	*1-634-841-11	PC BOARD, LEAF SW	C104	1-136-174-00	FILM 0.56MF 5% 50V
914	*1-634-842-11	PC BOARD, MD	C105	1-130-475-00	MYLAR 0.0022MF 5% 50V
C11	1-110-342-11	MYLAR 390PF 5% 50V	C106	1-130-475-00	MYLAR 0.0022MF 5% 50V
C12	1-136-157-00	FILM 0.022MF 5% 50V	C107	1-124-925-11	ELECT 2.2MF 20% 50V
C13	1-124-282-00	ELECT 22MF 20% 25V	C108	1-136-157-00	FILM 0.022MF 5% 50V
C21A	1-110-342-11	MYLAR 390PF 5% 50V	C109	1-162-294-31	CERAMIC 0.001MF 10% 50V
C21	1-124-902-00	ELECT 0.47MF 20% 50V	C110	1-124-902-00	ELECT 0.47MF 20% 50V
C22	1-136-157-00	FILM 0.022MF 5% 50V	C111	1-123-875-11	ELECT 10MF 20% 50V
C23	1-124-282-00	ELECT 22MF 20% 25V	C112	1-124-927-11	ELECT 4.7MF 20% 50V
C31	1-124-443-00	ELECT 100MF 20% 10V	C113	1-123-382-00	ELECT 3.3MF 20% 50V
C32	1-124-443-00	ELECT 100MF 20% 10V	C114	1-124-791-11	ELECT 1MF 20% 50V
C33	1-124-119-00	ELECT 330MF 20% 16V	C115	1-162-292-31	CERAMIC 680PF 10% 50V
C44	1-162-288-31	CERAMIC 330PF 10% 50V	C116	1-124-791-11	ELECT 1MF 20% 50V
C45	1-136-273-91	FILM 75PF 5% 630V	C201	1-124-927-11	ELECT 4.7MF 20% 50V
C51A	1-136-230-00	FILM 0.0022MF 5% 100V	C202	1-124-927-11	ELECT 4.7MF 20% 50V
C51	1-136-153-00	FILM 0.01MF 5% 50V	C203	1-136-171-00	FILM 0.33MF 5% 50V
C52A	1-136-230-00	FILM 0.0022MF 5% 100V	C204	1-136-174-00	FILM 0.56MF 5% 50V
C52	1-136-157-00	FILM 0.022MF 5% 50V	C205	1-130-475-00	MYLAR 0.0022MF 5% 50V
C53A	1-130-856-00	FILM 0.0068MF 5% 100V	C206	1-130-475-00	MYLAR 0.0022MF 5% 50V
C53	1-136-165-00	FILM 0.1MF 5% 50V	C207	1-124-925-11	ELECT 2.2MF 20% 50V
C54A	1-136-601-11	FILM 0.01MF 5% 630V	C208	1-136-157-00	FILM 0.022MF 5% 50V
C54	1-136-437-11	FILM 220PF 5% 630V	C209	1-162-294-31	CERAMIC 0.001MF 10% 50V
C55A	1-161-494-00	CERAMIC 0.022MF 25V	C210	1-124-902-00	ELECT 0.47MF 20% 50V
C55	1-136-433-11	FILM 100PF 5% 630V	C211	1-123-875-11	ELECT 10MF 20% 50V
C56A	1-126-157-11	ELECT 10MF 20% 16V	C212	1-124-927-11	ELECT 4.7MF 20% 50V
C56	1-130-472-00	MYLAR 0.0012MF 5% 50V	C213	1-123-382-00	ELECT 3.3MF 20% 50V
C64	1-162-288-31	CERAMIC 330PF 10% 50V	C214	1-124-791-11	ELECT 1MF 20% 50V
C65	1-136-273-91	FILM 75PF 5% 630V	C215	1-162-292-31	CERAMIC 680PF 10% 50V
C71A	1-123-875-11	ELECT 10MF 20% 50V	C216	1-124-791-11	ELECT 1MF 20% 50V
C71	1-136-153-00	FILM 0.01MF 5% 50V	C301	1-124-925-11	ELECT 2.2MF 20% 50V
C72A	1-123-875-11	ELECT 10MF 20% 50V	C302	1-124-925-11	ELECT 2.2MF 20% 50V
C72	1-136-157-00	FILM 0.022MF 5% 50V	C303	1-124-902-00	ELECT 0.47MF 20% 50V
C73	1-136-165-00	FILM 0.1MF 5% 50V	C304	1-162-215-31	CERAMIC 47PF 5% 50V
C74	1-136-437-11	FILM 220PF 5% 630V	C305	1-161-494-00	CERAMIC 0.022MF 25V
C75	1-136-433-11	FILM 100PF 5% 630V	C306	1-124-925-11	ELECT 2.2MF 20% 50V
			C307	1-124-925-11	ELECT 2.2MF 20% 50V
			C308	1-123-875-11	ELECT 10MF 20% 50V
			C309	1-123-875-11	ELECT 10MF 20% 50V

Ref.No.	Part No.	Description
C501	1-124-443-00	ELECT 100MF 20% 6.3V
C502	1-161-494-00	CERAMIC 0.022MF 25V
C503	1-124-791-11	ELECT 1MF 20% 50V
C504	1-123-875-11	ELECT 10MF 20% 50V
C505	1-164-159-11	CERAMIC 0.1MF 50V
C506	1-124-471-00	ELECT 1000MF 20% 6.3V
C701	1-124-887-00	ELECT 3300MF 20% 16V
C702	1-124-887-00	ELECT 3300MF 20% 16V
C703	1-126-176-11	ELECT 220MF 20% 10V
C704	1-124-473-11	ELECT 1000MF 20% 10V
C705	1-124-473-11	ELECT 1000MF 20% 10V
C706	1-124-925-11	ELECT 2.2MF 20% 50V
C707	1-124-472-11	ELECT 470MF 20% 6.3V
C708	1-124-911-11	ELECT 220MF 20% 50V
C709	1-124-927-11	ELECT 4.7MF 20% 50V
C710	1-124-927-11	ELECT 4.7MF 20% 50V
C711	1-124-927-11	ELECT 4.7MF 20% 50V
C712	1-124-120-11	ELECT 220MF 20% 16V
CNP21	*1-568-826-11	SOCKET, CONNECTOR 7P
CNP22	*1-565-347-11	SOCKET, CONNECTOR (PC BOARD) 8P
CNP31	*1-568-824-11	SOCKET, CONNECTOR 5P
CNP32	*1-564-709-11	PIN, CONNECTOR (SMALL TYPE) 7P
CNP34	*1-565-344-11	PIN, CONNECTOR (PC BOARD) 8P
CNP35	*1-564-706-11	PIN, CONNECTOR (SMALL TYPE) 4P
CNP71	*1-564-705-11	PIN, CONNECTOR (SMALL TYPE) 3P
CNP72	*1-564-706-11	PIN, CONNECTOR (SMALL TYPE) 4P
CNP73	*1-568-828-11	SOCKET, CONNECTOR 9P
CNP75	*1-564-704-11	PIN, CONNECTOR (SMALL TYPE) 2P
CNP81	*1-568-852-11	SOCKET, CONNECTOR 9P
CNP301	*1-568-824-11	SOCKET, CONNECTOR 5P
CNP302	*1-564-337-00	PIN, CONNECTOR 3P
CNP303	*1-564-705-11	PIN, CONNECTOR (SMALL TYPE) 3P
CNP501	*1-568-844-11	SOCKET, CONNECTOR 29P
CNP502	*1-568-871-11	SOCKET, CONNECTOR 29P
CNP503	*1-568-828-11	SOCKET, CONNECTOR 9P
CNP504	*1-568-828-11	SOCKET, CONNECTOR 9P
CNP505	*1-568-826-11	SOCKET, CONNECTOR 7P
CNP506	*1-564-339-00	PIN, CONNECTOR 5P
D31	8-719-107-94	DIODE 1SS202-1
D101	8-719-107-94	DIODE 1SS202-1
D201	8-719-107-94	DIODE 1SS202-1
D301	8-719-107-94	DIODE 1SS202-1
D302	8-719-107-94	DIODE 1SS202-1
D303	8-719-107-94	DIODE 1SS202-1
D501	8-719-301-38	DIODE SEL2210S-C (●REC)
D502	8-719-301-60	DIODE SEL2910A-C (■ PAUSE)
D503	8-719-301-44	DIODE SEL2410E-C (PLAY)
D504	8-719-301-60	DIODE SEL2910A-C (▷FWD)
D505	8-719-301-60	DIODE SEL2910A-C (◁REV)
D506	8-719-302-45	DIODE SEL1210S (TAPE TYPE I)
D507	8-719-302-45	DIODE SEL1210S (TAPE TYPE II)
D508	8-719-302-45	DIODE SEL1210S (TAPE TYPE IV)
D509	8-719-107-94	DIODE 1SS202-1
D510	8-719-107-94	DIODE 1SS202-1
D511	8-719-107-94	DIODE 1SS202-1
D512	8-719-107-94	DIODE 1SS202-1

Ref.No.	Part No.	Description
D513	8-719-107-94	DIODE 1SS202-1
D514	8-719-107-94	DIODE 1SS202-1
D701	8-719-200-77	DIODE 10E2N
D702	8-719-200-77	DIODE 10E2N
D703	8-719-200-77	DIODE 10E2N
D704	8-719-200-77	DIODE 10E2N
D705	8-719-200-77	DIODE 10E2N
D706	8-719-200-77	DIODE 10E2N
D707	8-719-933-33	DIODE UZS6A1L
D708	8-719-933-33	DIODE UZS6A1L
D709	8-719-000-78	DIODE UZL-7L2
D710	8-719-200-77	DIODE 10E2N
D711	8-719-107-94	DIODE 1SS202-1
D712	8-719-000-93	DIODE UZL-7H1
D713	8-719-107-94	DIODE 1SS202-1
D714	8-719-200-77	DIODE 10E2N
FL501	1-519-493-11	INDICATOR TUBE, FLUORESCENT
HRPE101	A-2003-477-A	BASE ASSY, HEAD
IC31	8-759-111-44	IC UPC4570C-1
IC51	8-759-106-56	IC UPC1297CA
IC81	8-719-939-23	IC GP2S09-C
IC301	8-752-036-34	IC CXA1330S
IC302	8-752-038-02	IC CXA1198AP
IC303	8-759-208-08	IC TC4052BPHB
IC304	8-759-945-58	IC RC4558P
IC305	8-759-601-02	IC M5218P
IC306	8-759-945-58	IC RC4558P
IC307	8-759-981-95	IC RC4558S
IC501	8-759-634-92	IC M50940-274SP
IC502	8-741-100-48	IC SBX1610-59
IC503	8-759-803-42	IC LA6500-FA
IC701	8-759-945-58	IC RC4558P
J301	1-565-258-11	JACK, PIN 4P (LINE IN/OUT)
J302	1-507-796-71	JACK (HEADPHONES)
J303	1-507-797-21	JACK, LARGE TYPE (MICROPHONE)
L41	1-410-780-11	INDUCTOR 27MMH
L61	1-410-780-11	INDUCTOR 27MMH
LPF101	1-236-087-11	FILTER, LOW PASS
LPF201	1-236-087-11	FILTER, LOW PASS
M1	X-3359-417-1	MOTOR ASSY, CAPSTAN
M2	A-2003-474-A	MOTOR (REEL MOTOR) ASSY
Q51	8-729-194-57	TRANSISTOR 2SC945-P
Q52	8-729-194-57	TRANSISTOR 2SC945-P
Q53	8-729-801-84	TRANSISTOR 2SB1013
Q71	8-729-820-16	TRANSISTOR 2SA1317-S
Q101	8-729-900-74	TRANSISTOR DTC143TS
Q102	8-729-900-74	TRANSISTOR DTC143TS
Q103	8-729-900-74	TRANSISTOR DTC143TS
Q201	8-729-900-74	TRANSISTOR DTC143TS
Q202	8-729-900-74	TRANSISTOR DTC143TS
Q203	8-729-900-74	TRANSISTOR DTC143TS
Q301	8-729-821-04	TRANSISTOR 2SA1317-STU
Q302	8-729-900-89	TRANSISTOR DTC144ES

Ref.No.	Part No.	Description			
Q501	8-729-801-84	TRANSISTOR	2SB1013-4		
Q502	8-729-900-63	TRANSISTOR	DTA124ES		
Q503	8-729-820-24	TRANSISTOR	2SC3330-T		
Q504	8-729-820-24	TRANSISTOR	2SC3330-T		
Q505	8-729-821-04	TRANSISTOR	2SA1317-STU		
Q506	8-729-821-04	TRANSISTOR	2SA1317-STU		
Q507	8-729-900-80	TRANSISTOR	DTC114ES		
Q508	8-729-900-89	TRANSISTOR	DTC144ES		
Q509	8-729-900-80	TRANSISTOR	DTC114ES		
Q510	8-729-900-61	TRANSISTOR	DTA114ES		
Q511	8-729-900-61	TRANSISTOR	DTA114ES		
Q512	8-729-900-61	TRANSISTOR	DTA114ES		
Q513	8-729-900-61	TRANSISTOR	DTA114ES		
Q514	8-729-900-80	TRANSISTOR	DTC114ES		
Q701	8-729-920-97	TRANSISTOR	2SB1187-EF		
Q702	8-729-209-15	TRANSISTOR	2SD2012		
Q703	8-729-900-80	TRANSISTOR	DTC114ES		
Q704	8-729-820-24	TRANSISTOR	2SC3330-T		
Q705	8-729-209-15	TRANSISTOR	2SD2012		
Q706	8-729-900-80	TRANSISTOR	DTC114ES		
Q707	8-729-118-01	TRANSISTOR	2SB1116		
Q708	8-729-821-04	TRANSISTOR	2SA1317-STU		
Q709	8-729-900-74	TRANSISTOR	DTC143TS		
R11	1-247-881-00	CARBON	120K	5%	1/4W
R12	1-249-405-11	CARBON	100	5%	1/4W
R13	1-247-882-11	CARBON	130K	5%	1/4W
R14	1-249-426-11	CARBON	5.6K	5%	1/4W
R21	1-247-881-00	CARBON	120K	5%	1/4W
R22	1-249-405-11	CARBON	100	5%	1/4W
R23	1-247-882-11	CARBON	130K	5%	1/4W
R24	1-249-426-11	CARBON	5.6K	5%	1/4W
R31	1-249-409-11	CARBON	220	5%	1/4W
R32	1-249-409-11	CARBON	220	5%	1/4W
R45	1-249-430-11	CARBON	12K	5%	1/4W
R51A	1-249-441-11	CARBON	100K	5%	1/4W
R51	1-249-431-11	CARBON	15K	5%	1/4W
R52A	1-249-441-11	CARBON	100K	5%	1/4W
R52	1-249-393-11	CARBON	10	5%	1/4W
R53A	1-249-429-11	CARBON	10K	5%	1/4W
R53	1-247-883-00	CARBON	150K	5%	1/4W
R54A	▲, 1-212-851-00	FUSIBLE	5.6	5%	1/4W F
R55A	1-249-429-11	CARBON	10K	5%	1/4W
R55	1-249-433-11	CARBON	22K	5%	1/4W
R65	1-249-430-11	CARBON	12K	5%	1/4W
R71A	1-247-864-11	CARBON	24K	5%	1/4W
R71	1-249-431-11	CARBON	15K	5%	1/4W
R72A	1-249-433-11	CARBON	22K	5%	1/4W
R72	1-249-393-11	CARBON	10	5%	1/4W
R73A	1-249-437-11	CARBON	47K	5%	1/4W
R73	1-247-883-00	CARBON	150K	5%	1/4W
R74	1-249-437-11	CARBON	47K	5%	1/4W
R75	1-249-433-11	CARBON	22K	5%	1/4W
R81	1-249-414-11	CARBON	560	5%	1/4W



Ref.No.	Part No.	Description			
R82	1-247-818-11	CARBON	300	5%	1/4W
R83	1-247-834-11	CARBON	1.3K	5%	1/4W
R84	1-249-417-11	CARBON	1K	5%	1/4W
R85	1-249-408-11	CARBON	180	5%	1/4W
R101	1-249-417-11	CARBON	1K	5%	1/4W
R102	1-249-431-11	CARBON	15K	5%	1/4W
R103	1-249-428-11	CARBON	8.2K	5%	1/4W
R104	1-249-421-11	CARBON	2.2K	5%	1/4W
R105	1-249-414-11	CARBON	560	5%	1/4W
R106	1-247-864-11	CARBON	24K	5%	1/4W
R107	1-249-428-11	CARBON	8.2K	5%	1/4W
R108	1-249-423-11	CARBON	3.3K	5%	1/4W
R110	1-249-420-11	CARBON	1.8K	5%	1/4W
R111	1-249-423-11	CARBON	3.3K	5%	1/4W
R112	1-247-887-00	CARBON	220K	5%	1/4W
R113	1-249-429-11	CARBON	10K	5%	1/4W
R114	1-249-425-11	CARBON	4.7K	5%	1/4W
R115	1-249-425-11	CARBON	4.7K	5%	1/4W
R116	1-249-425-11	CARBON	4.7K	5%	1/4W
R117	1-249-429-11	CARBON	10K	5%	1/4W
R118	1-249-421-11	CARBON	2.2K	5%	1/4W
R119	1-247-840-00	CARBON	2.4K	5%	1/4W
R120	1-249-409-11	CARBON	220	5%	1/4W
R121	1-249-429-11	CARBON	10K	5%	1/4W
R122	1-249-434-11	CARBON	27K	5%	1/4W
R123	1-249-433-11	CARBON	22K	5%	1/4W
R124	1-249-408-11	CARBON	180	5%	1/4W
R125	1-249-441-11	CARBON	100K	5%	1/4W
R126	1-249-429-11	CARBON	10K	5%	1/4W
R127	1-249-411-11	CARBON	330	5%	1/4W
R128	1-249-434-11	CARBON	27K	5%	1/4W
R129	1-249-437-11	CARBON	47K	5%	1/4W
R201	1-249-417-11	CARBON	1K	5%	1/4W
R202	1-249-431-11	CARBON	15K	5%	1/4W
R203	1-249-428-11	CARBON	8.2K	5%	1/4W
R204	1-249-421-11	CARBON	2.2K	5%	1/4W
R205	1-249-414-11	CARBON	560	5%	1/4W
R206	1-247-864-11	CARBON	24K	5%	1/4W
R207	1-249-428-11	CARBON	8.2K	5%	1/4W
R208	1-249-423-11	CARBON	3.3K	5%	1/4W
R210	1-249-420-11	CARBON	1.8K	5%	1/4W
R211	1-249-423-11	CARBON	3.3K	5%	1/4W
R212	1-247-887-00	CARBON	220K	5%	1/4W
R213	1-249-429-11	CARBON	10K	5%	1/4W
R214	1-249-425-11	CARBON	4.7K	5%	1/4W
R215	1-249-425-11	CARBON	4.7K	5%	1/4W
R216	1-249-425-11	CARBON	4.7K	5%	1/4W
R217	1-249-429-11	CARBON	10K	5%	1/4W
R218	1-249-421-11	CARBON	2.2K	5%	1/4W
R219	1-247-840-00	CARBON	2.4K	5%	1/4W
R220	1-249-409-11	CARBON	220	5%	1/4W
R221	1-249-429-11	CARBON	10K	5%	1/4W
R222	1-249-434-11	CARBON	27K	5%	1/4W
R223	1-249-433-11	CARBON	22K	5%	1/4W
R224	1-249-408-11	CARBON	180	5%	1/4W
R225	1-249-441-11	CARBON	100K	5%	1/4W
R226	1-249-429-11	CARBON	10K	5%	1/4W

Note:
The components identified by mark ▲ or dotted line with mark ▲ are critical for safety. Replace only with part number specified.

Note:
Les composants identifiés par une marque ▲ sont critiques pour la sécurité. Ne les remplacer que par une pièce portant le numéro spécifié.

Ref.No.	Part No.	Description			
R227	1-249-411-11	CARBON	330	5%	1/4W
R228	1-249-434-11	CARBON	27K	5%	1/4W
R229	1-249-437-11	CARBON	47K	5%	1/4W
R301	1-215-455-00	METAL	27K	1%	1/6W
R302	1-249-433-11	CARBON	22K	5%	1/4W
R303	1-249-433-11	CARBON	22K	5%	1/4W
R304	1-247-864-11	CARBON	24K	5%	1/4W
R305	1-249-436-11	CARBON	39K	5%	1/4W
R306	1-249-435-11	CARBON	33K	5%	1/4W
R307	1-249-437-11	CARBON	47K	5%	1/4W
R308	1-247-880-11	CARBON	110K	5%	1/4W
R309	1-249-440-11	CARBON	82K	5%	1/4W
R310	1-249-440-11	CARBON	82K	5%	1/4W
R311	1-247-874-11	CARBON	62K	5%	1/4W
R312	1-249-437-11	CARBON	47K	5%	1/4W
R313	1-249-438-11	CARBON	56K	5%	1/4W
R314	1-247-880-11	CARBON	110K	5%	1/4W
R315	1-247-878-00	CARBON	91K	5%	1/4W
R316	1-247-887-00	CARBON	220K	5%	1/4W
R317	1-247-874-11	CARBON	62K	5%	1/4W
R318	1-247-872-11	CARBON	51K	5%	1/4W
R319	1-249-435-11	CARBON	33K	5%	1/4W
R320	1-249-439-11	CARBON	68K	5%	1/4W
R321	1-247-882-11	CARBON	130K	5%	1/4W
R322	1-247-887-00	CARBON	220K	5%	1/4W
R323	1-249-429-11	CARBON	10K	5%	1/4W
R324	1-249-437-11	CARBON	47K	5%	1/4W
R325	1-249-423-11	CARBON	3.3K	5%	1/4W
R326	1-247-852-11	CARBON	7.5K	5%	1/4W
R327	1-249-434-11	CARBON	27K	5%	1/4W
R328	1-247-887-00	CARBON	220K	5%	1/4W
R329	1-249-429-11	CARBON	10K	5%	1/4W
R330	1-249-441-11	CARBON	100K	5%	1/4W
R331	1-249-428-11	CARBON	8.2K	5%	1/4W
R332	1-249-423-11	CARBON	3.3K	5%	1/4W
R333	1-249-417-11	CARBON	1K	5%	1/4W
R334	1-249-441-11	CARBON	100K	5%	1/4W
R335	1-249-429-11	CARBON	10K	5%	1/4W
R336	1-249-441-11	CARBON	100K	5%	1/4W
R337	1-249-417-11	CARBON	1K	5%	1/4W
R338	1-249-435-11	CARBON	33K	5%	1/4W
R339	1-249-413-11	CARBON	470	5%	1/4W
R340	1-249-413-11	CARBON	470	5%	1/4W
R341	1-249-417-11	CARBON	1K	5%	1/4W
R501	1-249-418-11	CARBON	1.2K	5%	1/4W
R502	1-249-415-11	CARBON	680	5%	1/4W
R503	1-249-412-11	CARBON	390	5%	1/4W
R504	1-249-409-11	CARBON	220	5%	1/4W
R505	1-249-409-11	CARBON	220	5%	1/4W
R506	1-249-412-11	CARBON	390	5%	1/4W
R507	1-249-420-11	CARBON	1.8K	5%	1/4W
R508	1-249-422-11	CARBON	2.7K	5%	1/4W
R509	1-249-428-11	CARBON	8.2K	5%	1/4W
R510	1-249-429-11	CARBON	10K	5%	1/4W
R511	1-249-409-11	CARBON	220	5%	1/4W
R512	1-249-409-11	CARBON	220	5%	1/4W
R513	1-249-409-11	CARBON	220	5%	1/4W

Ref.No.	Part No.	Description			
R514	1-249-421-11	CARBON	2.2K	5%	1/4W
R515	1-249-421-11	CARBON	2.2K	5%	1/4W
R516	1-247-891-00	CARBON	330K	5%	1/4W
R517	1-249-434-11	CARBON	27K	5%	1/4W
R518	1-247-862-11	CARBON	20K	5%	1/4W
R519	1-249-425-11	CARBON	4.7K	5%	1/4W
R520	1-249-412-11	CARBON	390	5%	1/4W
R521	1-249-410-11	CARBON	270	5%	1/4W
R522	1-249-409-11	CARBON	220	5%	1/4W
R523	1-249-411-11	CARBON	330	5%	1/4W
R524	1-249-411-11	CARBON	330	5%	1/4W
R525	1-247-903-00	CARBON	1M	5%	1/4W
R526	1-249-437-11	CARBON	47K	5%	1/4W
R529	1-249-433-11	CARBON	22K	5%	1/4W
R530	1-249-428-11	CARBON	8.2K	5%	1/4W
R531	1-249-421-11	CARBON	2.2K	5%	1/4W
R532	1-249-429-11	CARBON	10K	5%	1/4W
R533	1-249-429-11	CARBON	10K	5%	1/4W
R534	1-249-413-11	CARBON	470	5%	1/4W
R535	1-249-422-11	CARBON	2.7K	5%	1/4W
R536	1-249-422-11	CARBON	2.7K	5%	1/4W
R537	1-249-435-11	CARBON	33K	5%	1/4W
R538	1-249-422-11	CARBON	2.7K	5%	1/4W
R539	1-247-850-11	CARBON	6.2K	5%	1/4W
R540	1-247-872-11	CARBON	51K	5%	1/4W
R541	1-247-872-11	CARBON	51K	5%	1/4W
R542	1-249-437-11	CARBON	47K	5%	1/4W
R543	1-247-866-11	CARBON	30K	5%	1/4W
R544	1-249-393-11	CARBON	10	5%	1/4W
R545	1-249-429-11	CARBON	10K	5%	1/4W
R546	1-249-429-11	CARBON	10K	5%	1/4W
R547	1-249-435-11	CARBON	33K	5%	1/4W
R548	1-249-413-11	CARBON	470	5%	1/4W
R701	1-249-413-11	CARBON	470	5%	1/4W
R702	1-249-429-11	CARBON	10K	5%	1/4W
R703	1-247-858-11	CARBON	13K	5%	1/4W
R704	1-249-422-11	CARBON	2.7K	5%	1/4W
R705	1-249-426-11	CARBON	5.6K	5%	1/4W
R706	1-249-422-11	CARBON	2.7K	5%	1/4W
R707	1-249-413-11	CARBON	470	5%	1/4W
R708	1-249-417-11	CARBON	1K	5%	1/4W
R709	1-249-429-11	CARBON	10K	5%	1/4W
R710	1-249-429-11	CARBON	10K	5%	1/4W
R711	1-249-429-11	CARBON	10K	5%	1/4W
R712	1-249-421-11	CARBON	2.2K	5%	1/4W
R713	1-249-423-11	CARBON	3.3K	5%	1/4W
R714	1-249-428-11	CARBON	8.2K	5%	1/4W
R715	1-249-432-11	CARBON	18K	5%	1/4W
R716	1-249-433-11	CARBON	22K	5%	1/4W
R717	1-249-417-11	CARBON	1K	5%	1/4W
R730	△ 1-219-136-11	FUSIBLE	0.22	10%	1/4W
R731	△ 1-219-136-11	FUSIBLE	0.22	10%	1/4W
RV11	1-238-597-11	RES, ADJ, CARBON 1K (PB LEVEL L)			
RV21	1-238-597-11	RES, ADJ, CARBON 1K (PB LEVEL R)			
RV42	1-230-497-11	RES, ADJ, CARBON 22K (BIAS L)			

Note:
The components identified by mark  or dotted line with mark  are critical for safety. Replace only with part number specified.

Note:
Les composants identifiés par une marque  sont critiques pour la sécurité. Ne les remplacer que par une pièce portant le numéro spécifié.

Ref.No.	Part No.	Description
RV62	1-230-497-11	RES, ADJ, CARBON 22K (BIAS R)
RV71	1-238-600-11	RES, ADJ, CARBON 10K (SPEED)
RV72	1-238-600-11	RES, ADJ, CARBON 10K (SPEED)
RV101	1-238-016-11	RES, ADJ, CARBON 10K (REC LEVEL L)
RV201	1-238-016-11	RES, ADJ, CARBON 10K (REC LEVEL R)
RV301	1-238-097-11	RES, VAR, CARBON 20K/20K (REC LEVEL)
RY31	1-515-726-11	RELAY (REC/PB)
S81	1-571-958-11	SWITCH, PUSH (1 KEY)(STOP DET)
S82	1-571-281-21	SWITCH, LEAF (CrO2 DET)
S83	1-571-281-21	SWITCH, LEAF (METAL DET)
S84	1-571-281-21	SWITCH, LEAF (ERASE PROOF)
S85	1-571-281-21	SWITCH, LEAF (ERASE PROOF)
S86	1-571-281-21	SWITCH, LEAF (HALF DET)
S501	1-554-303-21	SWITCH, KEY BOARD (○REC MUTE)
S502	1-554-303-21	SWITCH, KEY BOARD (<REV)
S503	1-554-303-21	SWITCH, KEY BOARD (>FWD)
S504	1-554-303-21	SWITCH, KEY BOARD (PAUSE)
S505	1-554-303-21	SWITCH, KEY BOARD (■STOP)
S506	1-554-303-21	SWITCH, KEY BOARD (◀AMS)
S507	1-554-303-21	SWITCH, KEY BOARD (▶AMS)
S508	1-554-303-21	SWITCH, KEY BOARD (●REC)
S509	1-554-303-21	SWITCH, KEY BOARD (RESET)
S510	1-554-303-21	SWITCH, KEY BOARD (MEMORY)
S511	1-571-305-11	SWITCH, PUSH (1 KEY)(DIRECTION MODE)
S512	1-571-305-11	SWITCH, PUSH (1 KEY)(DOLBY NR)
S513	1-571-305-11	SWITCH, PUSH (1 KEY)(DOLBY NR B/C)
S701	1-570-103-21	SWITCH, PUSH (1 KEY)(POWER)
T51A	1-433-366-11	TRANSFORMER, BIAS OSCILLATION
T51	1-433-367-11	TRANSFORMER, BIAS OSSCILATION
T71	1-433-367-11	TRANSFORMER, BIAS OSSCILATION
T901	▲, 1-449-596-11	TRANSFORMER, POWER
TP91	*1-564-508-11	PLUG, CONNECTOR 5P
X501	1-577-358-21	VIBRATOR, CERAMIC (4MHz)
ACCESSORY & PACKING MATERIAL		
	1-559-533-11	CORD, CONNECTION
	*3-349-005-01	CUSHION
	*3-349-028-91	INDIVIDUAL CARTON
	*3-703-710-41	STICKER, SONY SYMBOL (12)
	3-703-450-01	(US)...INSTRUCTION
	3-751-937-21	MANUAL, INSTRUCTION
	3-751-937-31	(Canadian)...MANUAL, INSTRUCTION

Note:

The components identified by mark ▲ or dotted line with mark ▲ are critical for safety. Replace only with part number specified.

Note:

Les composants identifiés par une marque ▲ sont critiques pour la sécurité. Ne les remplacer que par une pièce portant le numéro spécifié.

