

# TC-RX55/RX55ES/RX410

## SERVICE MANUAL

*US Model*  
TC-RX55ES/RX410

*Canadian Model*  
TC-RX55/RX410

*AEP Model*

*UK Model*

*E Model*

TC-RX55



Photo: TC-RX410

### SPECIFICATIONS

Recording system 4-track 2-channel stereo  
Fast winding Approx. 90 sec. (with C-60 cassette)  
Bias AC Bias  
Signal-to-noise ratio (NAB, at peak level)

Cassette	DOLBY NR switch		
	OFF	B-TYPE ON	C-TYPE ON
TYPE IV (Sony METAL-ES)	58 dB	65 dB	71 dB
TYPE II (Sony UX-S)	57 dB	64 dB	70 dB
TYPE I (Sony HF-S)	54 dB	61 dB	67 dB

Total harmonic distortion 1.0 % (with Sony METAL-ES cassettes)

Frequency response

DOLBY NR OFF  
TC-RX410:

- With TYPE IV cassette (Sony METAL-ES)  
30–15,000 Hz ( $\pm 3$  dB)  
30–13,000 Hz ( $\pm 3$  dB, OVU recording)
- With TYPE II cassette (Sony UX-S)  
30–15,000 Hz ( $\pm 3$  dB)
- With TYPE I cassette (Sony HF-S)  
30–14,000 Hz ( $\pm 3$  dB)

TC-RX55/RX55ES:

- With TYPE IV cassette (Sony METAL-ES)  
20–20,000 Hz ( $\pm 3$  dB)  
30–15,000 Hz ( $\pm 3$  dB, OVU recording)
- With TYPE II cassette (Sony UX-S)  
30–17,000 Hz ( $\pm 3$  dB)
- With TYPE I cassette (Sony HF-S)  
30–15,000 Hz ( $\pm 3$  dB)

Model Name Using Similar Mechanism	TC-RX50/RX50ES TC-RX400
Tape Transport Mechanism Type	TCM-170RB11 (TC-RX55/RX55ES) TCM-170RB13 (TC-RX410)

Wow and flutter 0.09% WRMS (NAB)  
Inputs  
Microphone inputs (phone jack)  
Sensitivity 0.25 mV ( $-70$  dB)  
For a low-impedance microphone  
Line inputs (phono jacks)  
Sensitivity 77.5 mV ( $-20$  dB)  
Input impedance 50k ohms  
Outputs  
Line outputs (phono jacks)  
Output level 0.44 V ( $-5$  dB) at load impedance 47k ohms  
Load impedance over 10k ohms  
Headphones output (stereo phone jack)  
Output level  $-28$  dB at load impedance 8 ohms

— Continued on next page —

**SEE ADDITIONAL INFORMATION**

STEREO CASSETTE DECK  
**SONY**®



## General

### Power requirements

US, Canadian, E2 model: 120 V AC, 60 Hz  
 AEP, E3 model: 220 V AC, 50/60 Hz  
 UK model: 240 V AC, 50/60 Hz

### Power consumption

22 W (TC-RX410)  
 19 W (TC-RX55/RX55ES)

### Dimensions

TC-RX410:  
 Approx. 430 x 118 x 295 mm (w/h/d)  
 (17 x 4<sup>3</sup>/<sub>4</sub> x 11<sup>5</sup>/<sub>8</sub> inches)

TC-RX55/RX55ES:  
 Approx. 430 x 120 x 285 mm (w/h/d)  
 (17 x 4<sup>3</sup>/<sub>4</sub> x 11<sup>1</sup>/<sub>4</sub> inches)

including projecting parts and controls

### Weight

Approx. 3.9 kg (8 lbs 10 oz)

### Supplied accessory

Connecting cord (2)

Design and specifications are subject to change without notice.

## Features

- **The Dolby HX PRO\* system** to improve the linearity of the tape's high-range response during recording.
- **Cue & review and memory play functions** to provide easy access to a desired position.
- **B and C type Dolby NR\* systems** to reduce tape hiss noise.
- The optional remote control unit allows various operations to be remotely controlled.

\*Dolby noise reduction and HX Pro headroom extension manufactured under license from Dolby Laboratories Licensing Corporation. HX Pro originated by Bang & Olufsen.

"DOLBY", the double-D symbol  and "HX PRO" are trademarks of Dolby Laboratories Licensing Corporation.

### SAFETY-RELATED COMPONENT WARNING!!

COMPONENTS IDENTIFIED BY MARK  OR DOTTED LINE WITH MARK  ON THE SCHEMATIC DIAGRAMS AND IN THE PARTS LIST ARE CRITICAL TO SAFE OPERATION. REPLACE THESE COMPONENTS WITH SONY PARTS WHOSE PART NUMBERS APPEAR AS SHOWN IN THIS MANUAL OR IN SUPPLEMENTS PUBLISHED BY SONY.

### ATTENTION AU COMPOSANT AYANT RAPPORT À LA SÉCURITÉ!

LES COMPOSANTS IDENTIFIÉS PAR UNE MARQUE  SUR LES DIAGRAMMES SCHÉMATIQUES ET LA LISTE DES PIÈCES SONT CRITIQUES POUR LA SÉCURITÉ DE FONCTIONNEMENT. NE REMPLACER CES COMPOSANTS QUE PAR DES PIÈCES SONY DONT LES NUMÉROS SONT DONNÉS DANS CE MANUEL OU DANS LES SUPPLÉMENTS PUBLIÉS PAR SONY.

## MODEL IDENTIFICATION (TC-RX55)

— Specification Label Printed on Back Panel —

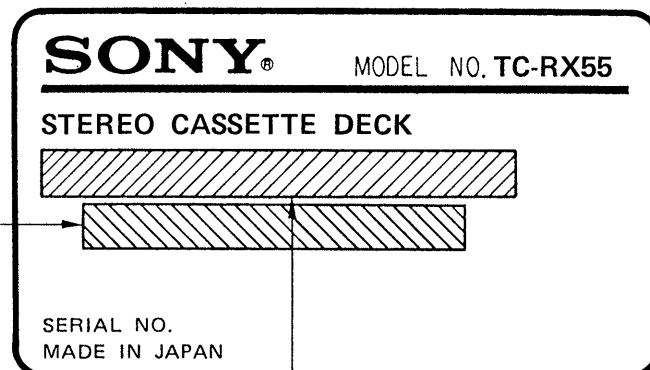

AEP, E3 Model: AC 220 V ~ 50/60 Hz  
 UK Model: AC 240 V ~ 50/60 Hz  
 Canadian, E2 Model: AC 120 V 60 Hz 19 W

(S) (D) (N) (+S) (FI) : AE2 only

## TABLE OF CONTENTS

<u>Section</u>	<u>Title</u>	<u>Page</u>
	Specifications . . . . .	1
	Features . . . . .	2
	Model Identification . . . . .	2
	Safety Check-out . . . . .	3
<b>1.</b>	<b>GENERAL</b>	
	Identification of Front Panel Parts . . . . .	3
<b>2.</b>	<b>ADJUSTMENTS</b>	
2-1.	Mechanical Adjustments . . . . .	4
2-2.	Electrical Adjustments . . . . .	4
<b>3.</b>	<b>DIAGRAMS</b>	
3-1.	Printed Wiring Boards . . . . .	8
3-2.	Schematic Diagram . . . . .	11
<b>4.</b>	<b>EXPLODED VIEWS . . . . .</b>	<b>15</b>
<b>5.</b>	<b>ELECTRICAL PARTS LIST . . . . .</b>	<b>19</b>

## SAFETY CHECK-OUT

After correcting the original service problem, perform the following safety check before releasing the set to the customer:

Check the antenna terminals, metal trim, "metallized" knobs, screws, and all other exposed metal parts for AC leakage. Check leakage as described below.

### LEAKAGE TEST

The AC leakage from any exposed metal part to earth ground and from all exposed metal parts to any exposed metal part having a return to chassis, must not exceed 0.5 mA (500 microamperes). Leakage current can be measured by any one of three methods.

1. A commercial leakage tester, such as the Simpson 229 or RCA WT-540A. Follow the manufacturers' instructions to use these instruments.

2. A battery-operated AC milliammeter. The Data Precision 245 digital multimeter is suitable for this job.
3. Measuring the voltage drop across a resistor by means of a VOM or battery-operated AC voltmeter. The "limit" indication is 0.75 V, so analog meters must have an accurate low-voltage scale. The Simpson 250 and Sanwa SH-63Trd are examples of a passive VOM that is suitable. Nearly all battery operated digital multimeters that have a 2V AC range are suitable. (See Fig. A)

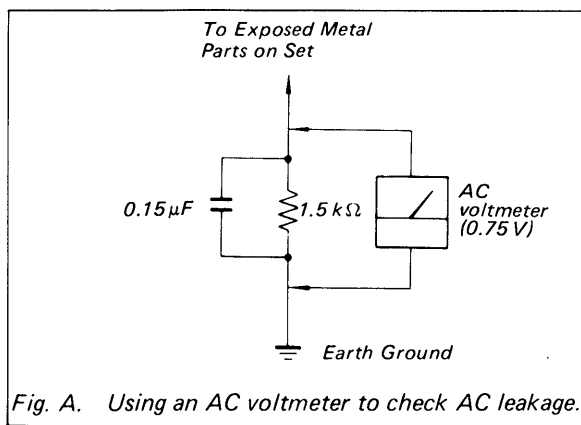
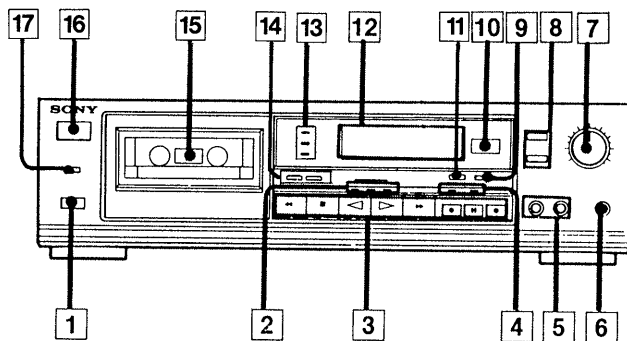

Fig. A. Using an AC voltmeter to check AC leakage.

## SECTION 1 GENERAL

### IDENTIFICATION OF FRONT PANEL PARTS



- 1 (eject) button
- 2 DIRECTION indicators
- 3 Tape operation buttons
  - (leftward fast winding) button
  - (rightward fast winding) button
  - (forward play) button
  - (reverse play) button
  - (stop) button
  - (pause) button
  - REC MUTE (record muting) button
  - REC (record) button
- 4 Tape transport mode indicators (REC, PAUSE)
- 5 MICROPHONE jacks (phone jacks)
- 6 HEADPHONES jack (stereo phone jack)

- 7 REC LEVEL (recording level) controls
- 8 DOLBY NR switches
- 9 DIRECTION MODE selector (TC-RX410)  
MPX FILTER switch (TC-RX55/RX55ES)
- 10 Remote control sensor
  - You can remotely control this cassette deck with:
    - A remote commander that has an mark and comes with a Sony amplifier or receiver and which can be used to control a cassette deck.
    - An optional Sony remote commander that has an mark.
- 11 DIRECTION MODE selector (TC-RX55/RX55ES)
- 12 PEAK LEVEL METER and DIGITAL COUNTER (TC-RX55/RX55ES)
- 13 TAPE TYPE indicators (TC-RX55/RX55ES)
- 14 COUNTER RESET and MEMORY buttons (TC-RX55/RX55ES)
- 15 Cassette holder
- 16 POWER switch
- 17 TIMER switch (TC-RX55/RX55ES)

# SECTION 2 ADJUSTMENTS

SEE ADDITIONAL  
SEE INFORMATION

## 2-1. MECHANICAL ADJUSTMENTS

### PRECAUTION

- Clean the following parts with a denatured-alcohol-moistened swab :
 

record/playback head	pinch roller
erase head	rubber belts
capstan	idler
- Demagnetize the record/playback head with a head demagnetizer.
- Do not use a magnetized screwdriver for the adjustments.
- After the adjustments, apply suitable locking compound to the parts adjusted.
- The adjustments should be performed with the rated power supply voltage unless otherwise noted.
- Switch position

DOLBY NR : OFF  
 B/C : B  
 MPX FILTER : OFF  
 DIRECTION MODE :  $\rightleftharpoons$   
 TIMER : OFF

### Torque Measurement

Torque	Torque Meter	Meter Reading
FWD	CQ-102C	27 to 75g · cm (0.378 to 1.05 oz · inch)
FWD Back tension	CQ-102C	1 to 10g · cm (0.014 to 0.14 oz · inch)
REV	CQ-102RC	27 to 75g · cm (0.378 to 1.05 oz · inch)
REV Back Tension	CQ-102RC	1 to 10g · cm (0.014 to 0.14 oz · inch)
FF, REW	CQ-102B	95 to 165g · cm (1.33 to 2.31 oz · inch)

## 2-2. ELECTRICAL ADJUSTMENTS

**Note :** The adjustment should be performed in the order given in the service manual.

The adjustments should be performed for both L-CH and R-CH.

- Switches and controls should be set as follows unless otherwise specified.

DOLBY NR switch : OFF  
 DIRECTION MODE switch :  $\rightleftharpoons$   
 TIMER switch : OFF  
 TAPE SELECT switch : According to the tape type.

Tape	TAPE Switch
CS-17	TYPE I
CS-26	TYPE II
CS-42	TYPE IV

- Standard Record :

Deliver the standard input signal level to the input jack and set the REC LEVEL control to obtain the standard output signal level.

—Record Mode—

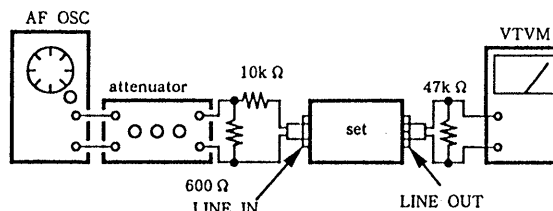

### Standard Input Level

	LINE IN
source impedance	10k Ω
input level	0.25V (-10dB)

### Standard Output Level

	LINE OUT
load impedance	47k Ω
output level	0.44V (-5dB)

### • Test tape

Type	Signal	Used for
P-4-A100	10kHz, -10dB	Azimuth Adjustment
P-4-L300	315Hz, 0dB	PB LEVEL Adjustment
WS-48B	3kHz, 0dB	Tape Speed Adjustment

### Record/Playback Head Azimuth Adjustment

#### Procedure :

- Mode : FWD playback

test tape  
 P-4-A100  
 (10kHz, -10dB)

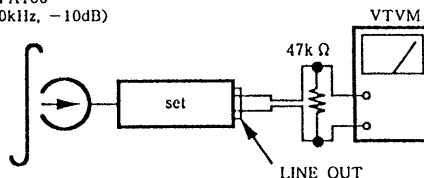

- Turn the adjustment screw for the maximum output levels. If these levels do not match, turn the adjustment screw until both of output levels match together within 1dB.

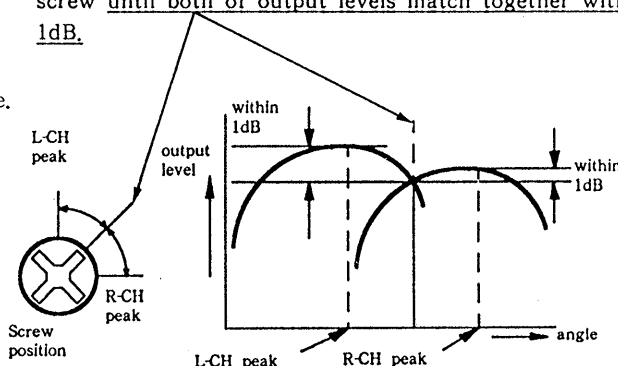

3. Phase Check  
Mode : playback

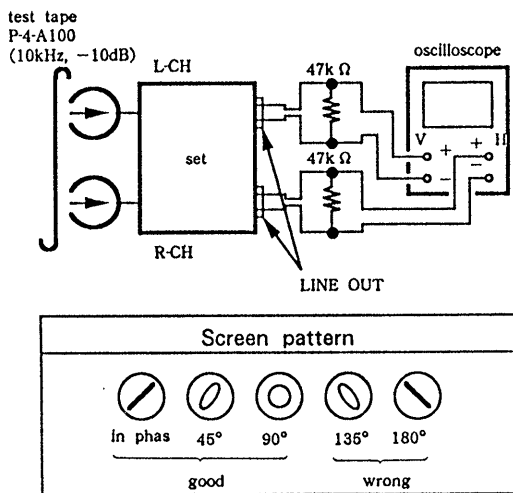

4. Set in the REV mode and repeat the step 1-3.  
5. After the adjustment, lock the screws with locking compound.

**Adjustment Location :** Record/Playback head

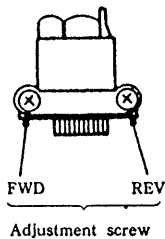

**Tape Speed Adjustment**

**Procedure :**  
Mode : FWD playback

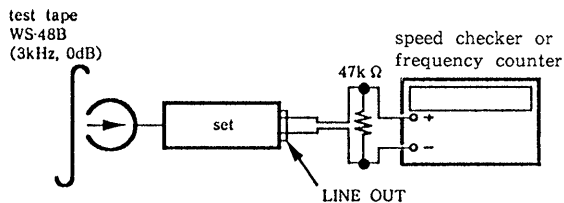

**Specifications :**

SPEED CHECKER	FREQUENCY COUNTER
0.19%	2,965~2,995Hz

Adjust the variable resistor which built-in the motor so that the frequency difference between the beginning and the end of the tape should be contented within 1.5% (45Hz).

**Adjustment Location :**  
: motor (M901) rear side

**Playback Level Adjustment**

**Procedure :**  
Mode : playback

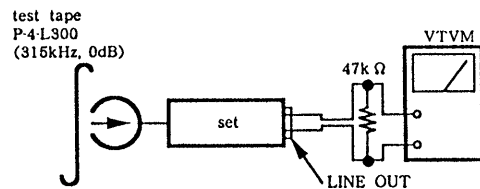

Adjust RV41 (L-CH), RV61 (R-CH) so that the reading on VTVM meets the specification below.

**Specification :**

LINE OUT level :  $-5 \pm 0.5\text{dB}$  (0.41~0.46V)

Level difference between channels : less than 0.5dB

Check that the LINE OUT level does not change in playback mode while changing the mode from playback to stop several times.

**Adjustment Location :** MD (B) board

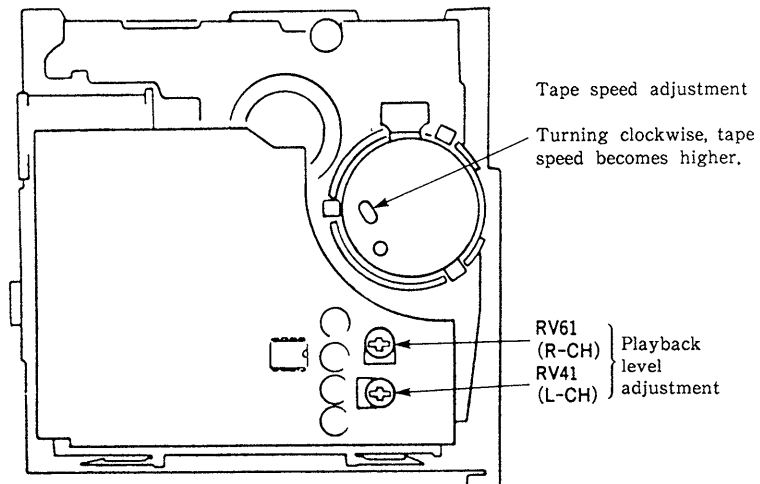

## Record Bias Adjustment

### Setting :

REC LEVEL control : standard record (See page 4.)

### Procedure :

#### 1. Mode : record

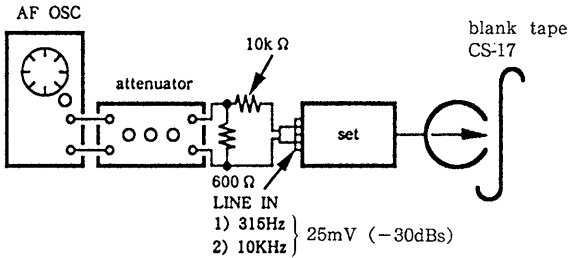

#### 2. Mode : playback

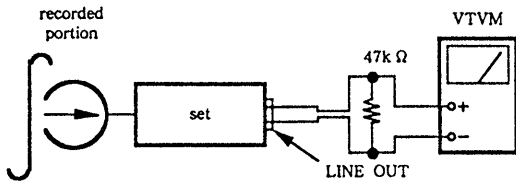

Confirm that the 10kHz playback output is  $0 \pm 0.5\text{dB}$  relative to the 315Hz output. If necessary, adjust RV42 (L-CH), RV62 (R-CH) and repeat the steps given above.

**Adjustment Location :** HX PRO board

### Recording bias adjustment

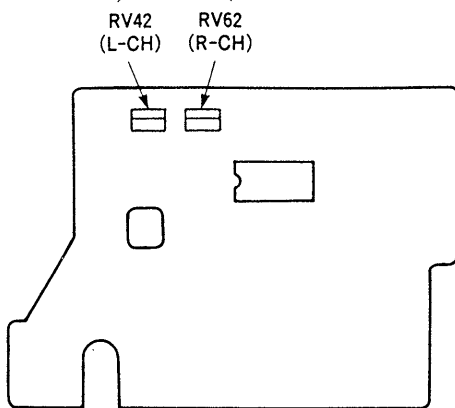

## Record Level Adjustment

### Setting :

REC LEVEL control : standard record (See page 4.)

### Procedure :

#### 1. Mode : record

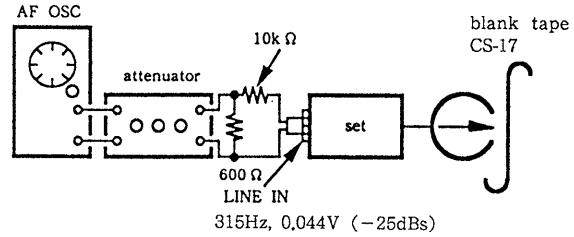

#### 2. Mode : playback

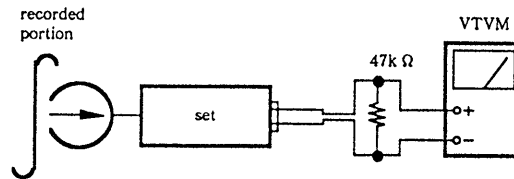

#### 3. Play back the signal recorded in step 1.

Confirm that the signal level is within the specification below. If necessary, adjust RV101 (L-CH), RV201 (R-CH) and repeat the step 1-3.

**Specification :** LINE OUT level :  $-25\text{dB} \pm 0.5\text{dBs}$  (0.041~0.046V)

**Adjustment Location :** MAIN board

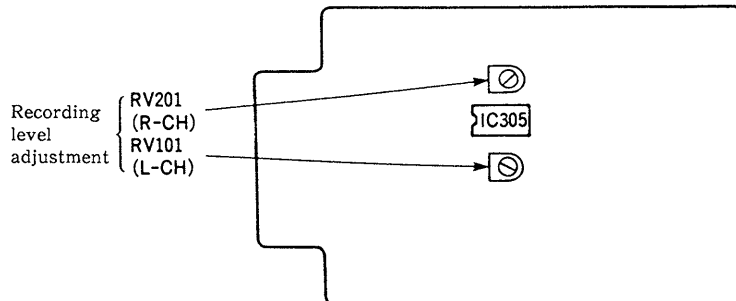







1 2 3 4 5 6 7 8 9 10 11 12 13 14 15 16 17 18 19 20 21 22 23 24 25 26 27 28 29 30

A  
B  
C  
D  
E  
F  
G  
H  
I  
J  
K  
L  
M  
N  
O  
P

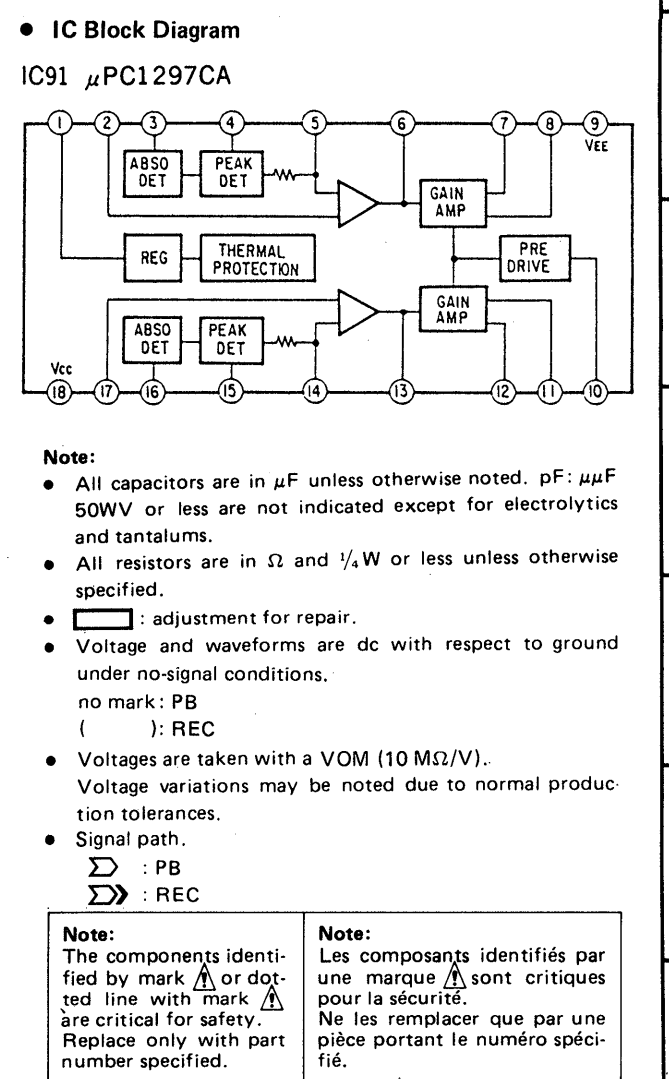
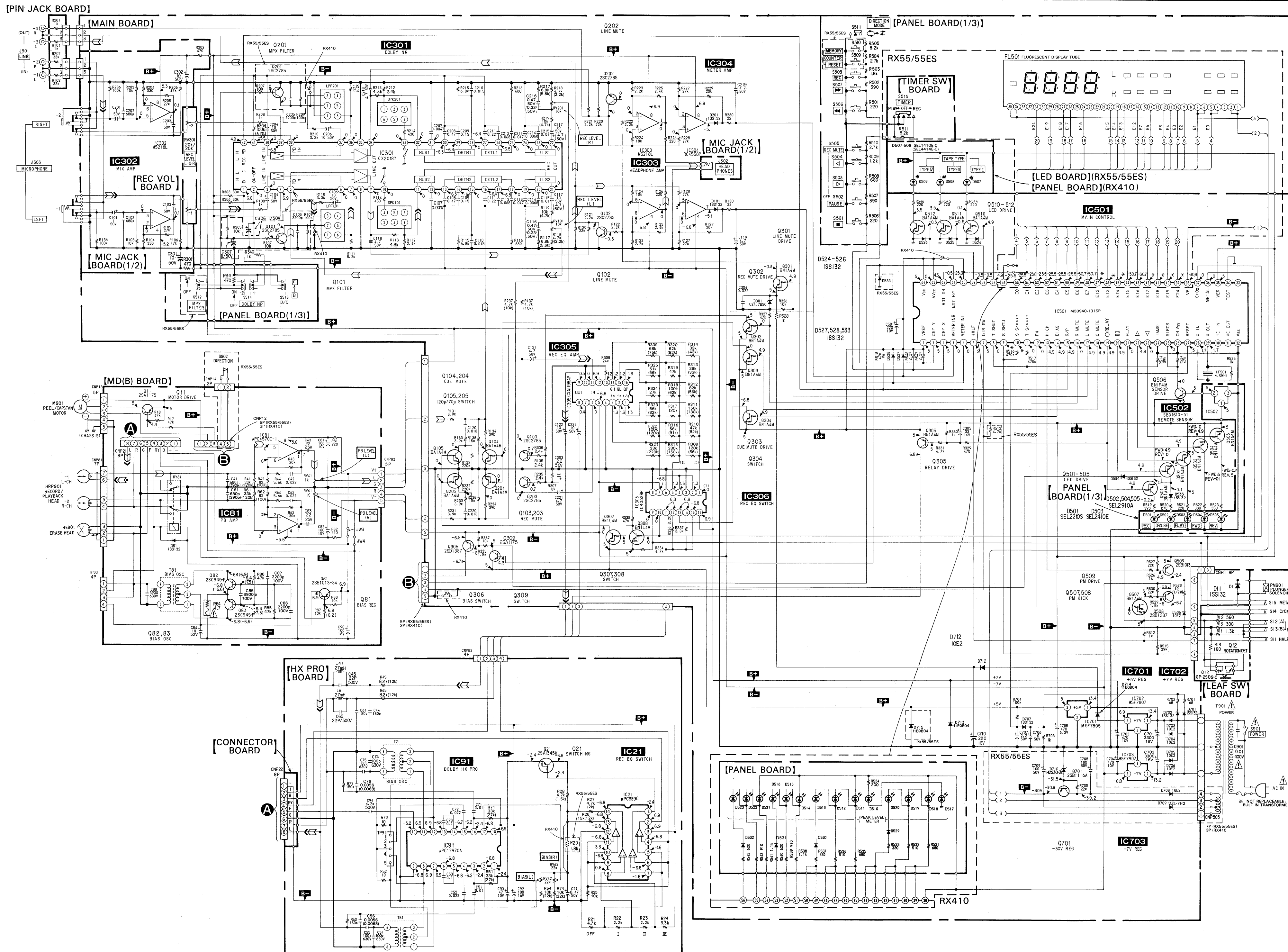



# SECTION 4 EXPLODED VIEWS

**NOTE:**

- The mechanical parts with no reference number in the exploded views are not supplied.
- The construction parts of an assembled part are indicated with a collation number in the remark column.
- Items marked "★" are not stocked since they are seldom required for routine service. Some delay should be anticipated when ordering these items.

- Due to standardization, parts with part number suffix -XX and -X may be different from the parts specified in the components used on the set.
- Color Indication of Appearance Parts  
Example:  
(RED) ... KNOB, BALANCE (WHITE)  
↑ Cabinet's Color                      ↑ Parts' Color

The components identified by mark or dotted line with mark are critical for safety. Replace only with part number specified.

Les composants identifiés par une marque sont critiques pour la sécurité. Ne les remplacer que par une pièce portant le numéro spécifié.

**(1) CABINET AND MAIN BOARDS SECTION**

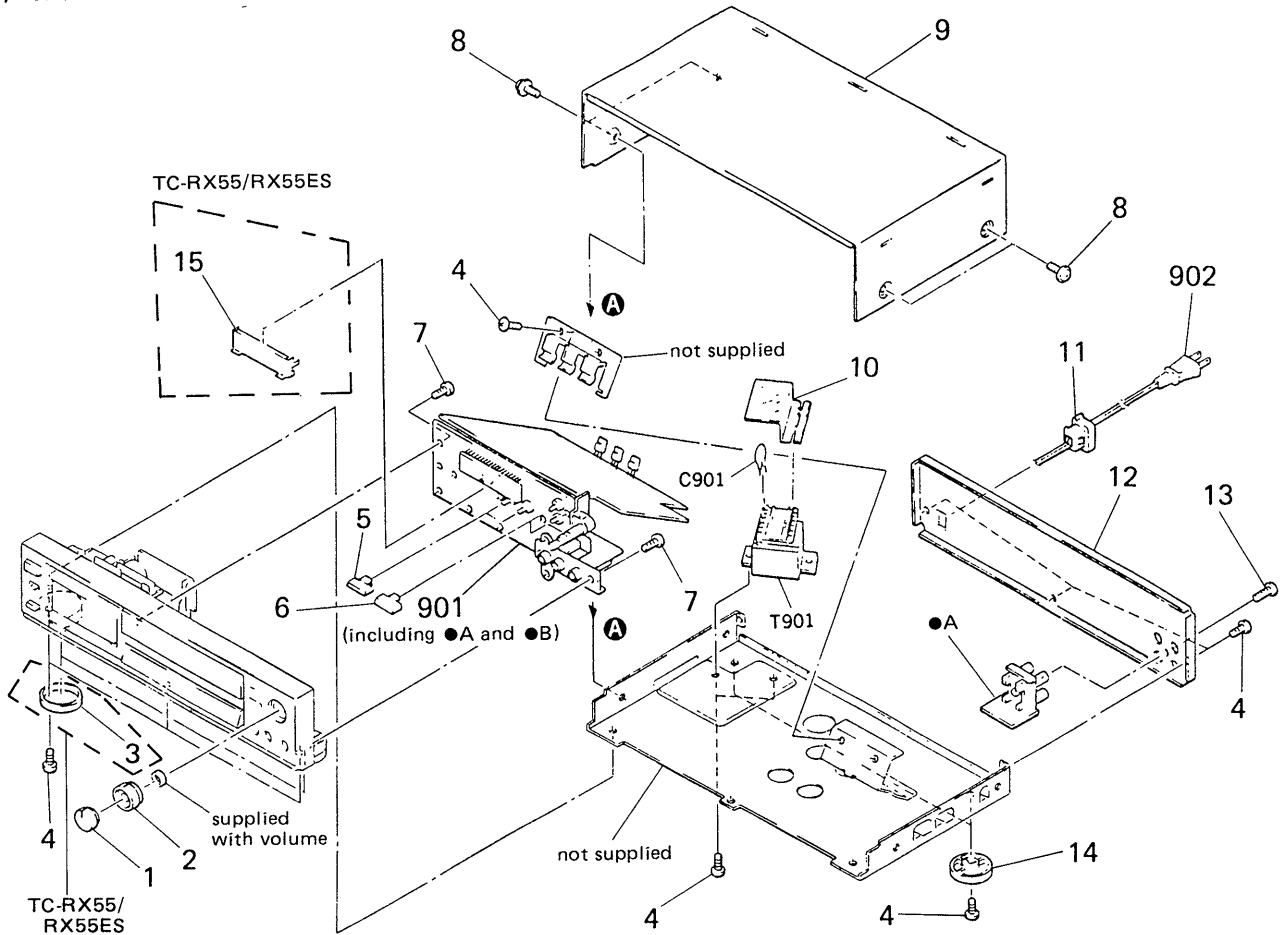

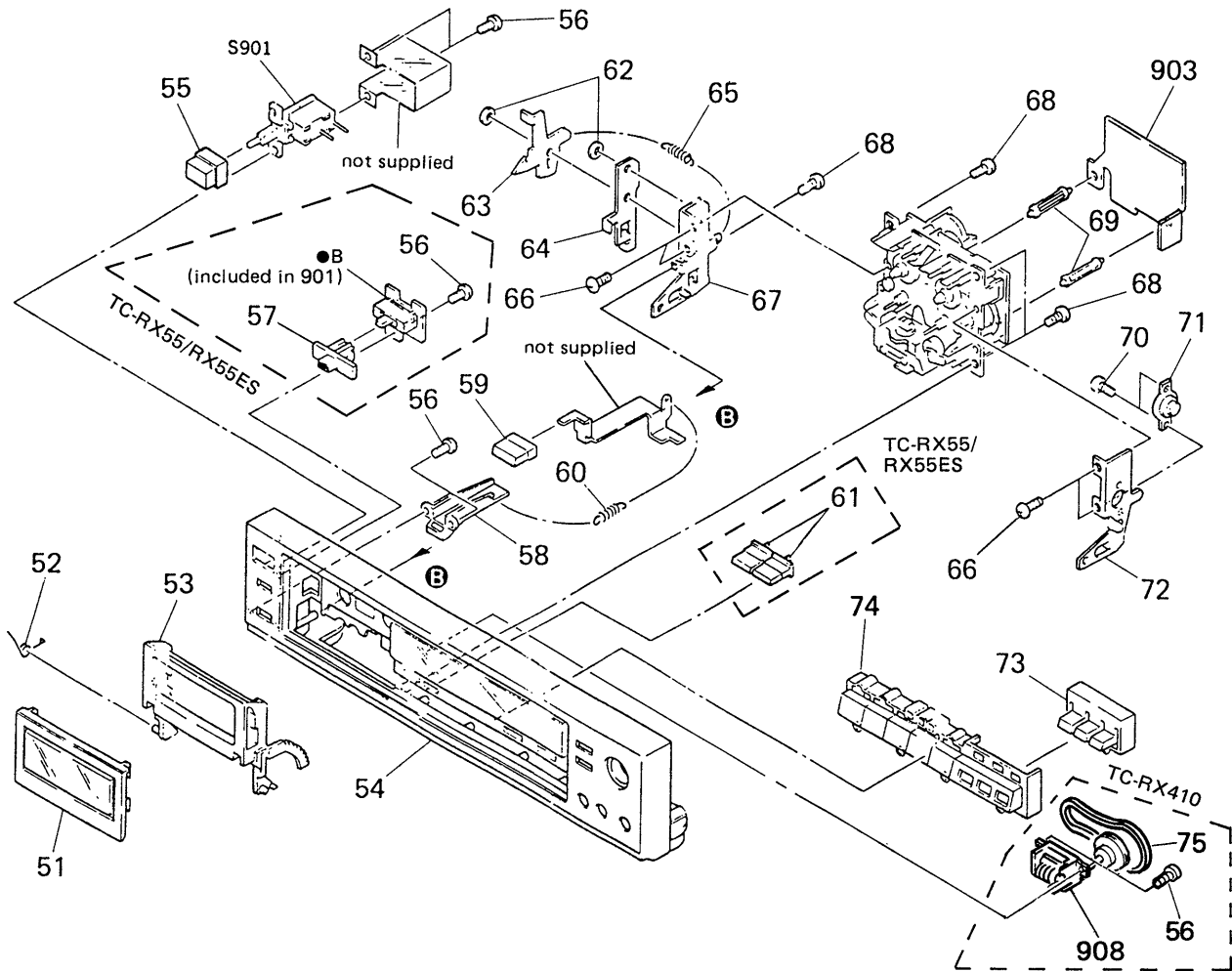

No.	Part No.	Description	Remarks	No.	Part No.	Description	Remarks
1	3-332-590-01	KNOB (REC VOL-RIGHT)		13	7-621-849-00	SCREW, TAPPING	
2	3-332-589-01	KNOB (REC VOL-LEFT)		14	X-4885-935-1	(RX55:AEP/UK/E3,RX55ES)...FOOT ASSY	
3	4-929-030-11	(RX55,RX55ES)...RING (DIA.58A), ORNAMENTAL			X-4911-201-1	(RX410,RX55:Canadian/E2)...FOOT ASSY	
4	7-682-548-04	SCREW +BVTT 3X8 (S)		15	*3-350-824-01	(RX55,RX55ES)...HOLDER (FL)	
5	3-350-810-01	BUTTON		901	*A-2006-064-A	(RX55,RX55ES)...MOUNTED PCB, AUDIO	
6	3-350-809-01	BUTTON			*A-2006-073-A	(RX410)...MOUNTED PCB, AUDIO	
7	4-928-635-01	SCREW, +BV (2.6X8) TAPPING		902	.1-551-506-XX	(US,Canadian,E3)...CORD, POWER	
8	3-704-366-01	SCREW (CASE) (M3X8)			.1-551-884-32	(UK)...CORD, POWER	
9	3-332-578-61	CASE			.1-555-795-00	(AEP,E3)...CORD, POWER, EURO PLUG	
10	*3-337-136-01	COVER, TRANSFORMER SAFETY		C901	.1-161-744-00	CAP, CERAMIC 10000PF FZ	
11	*3-703-244-00	(AEP,UK,E3)...BUSHING (2104), CORD					
	3-703-571-00	(US,Canadian,E2) ...BUSHING (S) (4516), CORD					
12	*3-350-802-11	(RX55:UK).....PANEL, BACK					
	*3-350-802-21	(RX55:AE1/West Germany/E3)...PANEL, BACK					
	*3-350-802-31	(RX55:AE2).....PANEL, BACK					
	*3-350-802-41	(RX55ES).....PANEL, BACK					
	*3-350-802-51	(RX410).....PANEL, BACK					
	*3-350-802-61	(RX55,Canadian)...PANEL, BACK					

(2) FRONT PANEL SECTION



No.	Part No.	Description	Remarks	No.	Part No.	Description	Remarks
51	X-3332-555-1 X-3332-556-1 X-3332-560-1	(RX55ES)...LID ASSY, CASSETTE (RX55).....LID ASSY, CASSETTE (RX410)....LID ASSY, CASSETTE		64	*3-346-306-01	LEVER (EJECT)	
52	3-346-336-01	SPRING, TORSION		65	3-312-432-00	SPRING, TENSION	
53	X-3332-482-1	HOLDER ASSY, CASSETTE		66	7-621-773-86	SCREW +BVTT 2.6X4 (S)	
54	X-3332-558-1 X-3332-559-1 X-3332-561-1	(RX55ES)...PANEL ASSY, FRONT (RX55).....PANEL ASSY, FRONT (RX410)....PANEL ASSY, FRONT		67	*X-3332-487-1	BRACKET ASSY (B)	
55	4-917-460-01	KNOB, POWER		68	7-685-534-19	SCREW +BTP 2.6X8 TYPE2 N-S	
56	4-928-635-01	SCREW, +BV (2.6X8) TAPPING		69	*3-682-419-21	HOLDER, P.C.B	
57	3-307-538-11	(RX55,RX55ES)...KNOB, SWITCH, TIMER		70	7-621-255-15	SCREW +PTT 2X3 (S)	
58	*3-349-017-01	RETAINER, SLIDER		71	3-319-224-31	DAMPER, SMALL	
59	3-343-698-21	BUTTON (EJECT)		72	*3-346-305-01	BRACKET (DAMPER)	
60	3-662-752-21	SPRING, TENSION		73	3-350-813-01	BUTTON (B)	
61	3-350-812-01	(RX55,RX55ES)...BUTTON (COUNTER)		74	3-350-819-01	BUTTON (A)	
62	3-558-708-21	WASHER, STOPPER		75	3-506-040-XX	(RX410)...BELT, SQUARE	
63	*3-343-449-01	LEVER (LOCK LEVER)		903	*1-630-423-11	PC BOARD, HX PRO	
				908	1-548-596-31	(RX410)...COUNTER, TAPE (MIDDLE TYPE)	
				S901	△.1-553-318-71	SWITCH, PUSH (AC POWER)(1 KEY)	
				T901	△.1-449-596-11	(RX55ES,RX55:Canadian/E2) ...TRANSFORMER, POWER	
				T901	△.1-449-597-11	(RX55:AEP/UK/E3)...TRANSFORMER, POWER	
				T901	△.1-449-598-11	(RX410).....TRANSFORMER, POWER	

<p><b>Note:</b> The components identified by mark  or dotted line with mark  are critical for safety. Replace only with part number specified.</p>	<p><b>Note:</b> Les composants identifiés par une marque  sont critiques pour la sécurité. Ne les remplacer que par une pièce portant le numéro spécifié.</p>
--	--

(3) TAPE TRANSPORT MECHANISM SECTION-1  
 (TCM-170RB11 (TC-RX55/RX55ES)/170RB13 (TC-RX410))

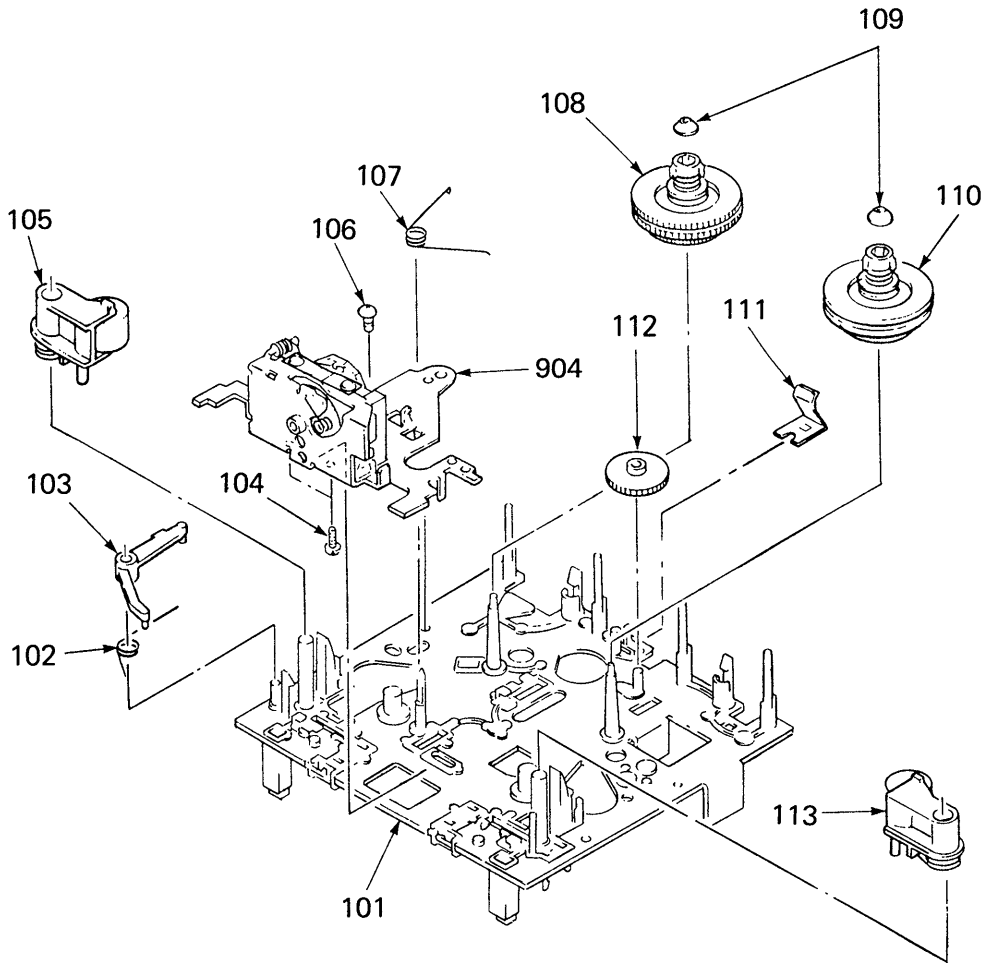

No.	Part No.	Description	Remarks	No.	Part No.	Description	Remarks
101	*X-3343-418-1	CHASSIS ASSY, MECHANICAL		109	3-343-439-01	CAP (REEL TABLE)	
102	3-343-477-01	SPRING, TORSION (EJECT SAFTY)		110	X-3343-401-1	TABEL ASSY, REEL	
103	*3-343-476-01	LEVER (EJECT SAFETY LEVER)		111	3-343-420-01	SPRING, LEAF	
104	7-685-102-19	SCREW +P 2X4 NON-SLIT TYPE 2		112	3-343-411-01	GEAR (FF GEAR)	
105	X-3343-403-1	LEVER (PINCH LEVER REV) ASSY		113	X-3343-402-1	LEVER (PINCH LEVER FWD) ASSY	
106	7-621-773-86	SCREW +BVTT 2.6X4 (S)		904	A-2108-124-A	(RX55,RX55ES)	
107	3-343-401-01	SPRING, TORSION				...CHASSIS ASSY, HEAD (HE901,HRP901)	
108	X-3343-415-1	TABEL (REV) ASSY, REEL			A-2108-130-A	(RX410)	
						...CHASSIS ASSY, HEAD (HE901,HRP901)	



## SECTION 5 ELECTRICAL PARTS LIST

**NOTE:**

- Due to standardization, replacements in the parts list may be different from the parts specified in the diagrams or the components used on the set.
- Items marked "★" are not stocked since they are seldom required for routine service. Some delay should be anticipated when ordering these items.
- If there are two or more same circuits in a set such as a stereophonic machine, only typical circuit parts may be indicated and capacitors and resistors in other same circuits may be omitted.

**CAPACITORS:**

MF:  $\mu$ F, PF:  $\mu$  $\mu$ F.

**RESISTORS**

- All resistors are in ohms.
- F: nonflammable

**COILS**

- MMH: mH, UH:  $\mu$ H

**SEMICONDUCTORS**

In each case, U:  $\mu$ , for example:

UA...:  $\mu$ A..., UPA...:  $\mu$ PA...,  
UPC...:  $\mu$ PC, UPD...:  $\mu$ PD...

The components identified by mark or dotted line with mark are critical for safety. Replace only with part number specified.

Les composants identifiés par une marque sont critiques pour la sécurité. Ne les remplacer que par une pièce portant le numéro spécifié.

Ref.No.	Part No.	Description	Ref.No.	Part No.	Description
901	*A-2006-064-A	(RX55,RX55ES)...MOUNTED PCB, AUDIO	C85	1-130-856-00	FILM 0.0068MF 5% 100V
	*A-2006-073-A	(RX410).....MOUNTED PCB, AUDIO	C86	1-136-230-00	FILM 0.0022MF 5% 100V
902	.1-551-506-XX	(US,Canadian,E)...CORD, POWER	C87	1-136-230-00	FILM 0.0022MF 5% 100V
	.1-551-884-32	(UK).....CORD, POWER	C88	1-136-558-11	FILM 0.0039MF 5% 630V
	.1-555-795-00	(AEP,E3)...CORD, POWER, EURO PLUG	C90	1-126-101-11	ELECT 100MF 20% 16V
903	*1-630-423-11	PC BOARD, HX PRO	C92	1-126-101-11	ELECT 100MF 20% 16V
904	A-2108-124-A	(RX55,RX55ES)...CHASSIS ASSY, HEAD	C93	1-124-446-11	ELECT 47MF 20% 10V
		(HE901,HRP901)	C94	1-107-046-00	MICA 4.7PF 0.5PF 500V
	A-2108-130-A	(RX410)...CHASSIS ASSY, HEAD	C101	1-124-499-11	ELECT 1MF 20% 50V
		(HE901,HRP901)	C102	1-162-292-31	CERAMIC 680PF 10% 50V
905	X-3343-408-1	MOTOR ASSY (M901)	C103	1-124-499-11	ELECT 1MF 20% 50V
906	*1-629-211-11	PC BOARD, MD (B)	C104	1-123-875-11	ELECT 10MF 20% 50V
907	*1-624-148-11	PC BOARD, LEAF SW	C105	1-161-375-00	(RX55,RX55ES)..CERAMIC 0.0022MF 30% 16V
908	1-548-596-31	(RX410)...COUNTER, TAPE (MIDDLE TYPE)	C106	1-123-875-11	ELECT 10MF 20% 50V
C21	1-124-902-00	ELECT 0.47MF 20% 50V	C107	1-130-479-00	MYLAR 0.0047MF 5% 50V
C41	1-110-342-11	(RX410).....MYLAR 390PF 5% 50V	C108	1-136-173-00	FILM 0.47MF 5% 50V
C41	1-130-469-00	(RX55,RX55ES)...MYLAR 680PF 5% 50V	C109	1-136-167-00	FILM 0.15MF 5% 50V
C42	1-136-157-00	FILM 0.022MF 5% 50V	C110	1-136-155-00	FILM 0.015MF 5% 50V
C43	1-124-282-00	ELECT 22MF 20% 25V	C111	1-136-169-00	FILM 0.22MF 5% 50V
C44	1-162-285-31	CERAMIC 180PF 10% 50V	C112	1-136-163-00	FILM 0.068MF 5% 50V
C45	1-107-210-00	MICA 22PF 5% 500V	C113	1-136-161-00	FILM 0.047MF 5% 50V
C51	1-136-153-00	FILM 0.01MF 5% 50V	C114	1-130-481-00	MYLAR 0.0068MF 5% 50V
C52	1-136-157-00	FILM 0.022MF 5% 50V	C115	1-136-153-00	FILM 0.01MF 5% 50V
C53	1-136-165-00	FILM 0.1MF 5% 50V	C116	1-124-252-00	(RX410).....ELECT 0.33MF 20% 50V
C54	1-136-433-11	FILM 100PF 5% 630V	C116	1-124-902-00	(RX55,RX55ES)...ELECT 0.47MF 20% 50V
C55	1-136-433-11	FILM 100PF 5% 630V	C117	1-123-875-11	(RX55,RX55ES)...ELECT 10MF 20% 50V
C56	1-130-468-00	(RX55,RX55ES)...MYLAR 560PF 5% 50V	C117	1-124-927-11	(RX410).....ELECT 4.7MF 20% 50V
C56	1-130-469-00	(RX410).....MYLAR 680PF 5% 50V	C118	1-124-768-11	ELECT 4.7MF 20% 50V
C61	1-110-342-11	(RX410).....MYLAR 390PF 5% 50V	C119	1-124-927-11	ELECT 4.7MF 20% 50V
C61	1-130-469-00	(RX55,RX55ES)...MYLAR 680PF 5% 50V	C120	1-136-156-00	FILM 0.018MF 5% 50V
C62	1-136-157-00	FILM 0.022MF 5% 50V	C121	1-124-927-11	ELECT 4.7MF 20% 50V
C63	1-124-282-00	ELECT 22MF 20% 25V	C122	1-123-875-11	ELECT 10MF 20% 50V
C64	1-162-285-31	CERAMIC 180PF 10% 50V	C201	1-124-499-11	ELECT 1MF 20% 50V
C65	1-107-210-00	MICA 22PF 5% 500V	C202	1-162-292-31	CERAMIC 680PF 10% 50V
C71	1-136-153-00	FILM 0.01MF 5% 50V	C203	1-124-499-11	ELECT 1MF 20% 50V
C72	1-136-157-00	FILM 0.022MF 5% 50V	C204	1-123-875-11	ELECT 10MF 20% 50V
C73	1-136-165-00	FILM 0.1MF 5% 50V	C205	1-161-375-00	(RX55,RX55ES)..CERAMIC 0.0022MF 30% 16V
C74	1-136-433-11	FILM 100PF 5% 630V	C206	1-123-875-11	ELECT 10MF 20% 50V
C75	1-136-433-11	FILM 100PF 5% 630V	C207	1-130-479-00	MYLAR 0.0047MF 5% 50V
C76	1-130-468-00	(RX55,RX55ES)...MYLAR 560PF 5% 50V	C208	1-136-173-00	FILM 0.47MF 5% 50V
C76	1-130-469-00	(RX410).....MYLAR 680PF 5% 50V	C209	1-136-167-00	FILM 0.15MF 5% 50V
C81	1-124-443-00	ELECT 100MF 20% 10V	C210	1-136-155-00	FILM 0.015MF 5% 50V
C82	1-124-443-00	ELECT 100MF 20% 10V	C211	1-136-169-00	FILM 0.22MF 5% 50V
C84	1-123-875-11	ELECT 10MF 20% 50V	C212	1-136-163-00	FILM 0.068MF 5% 50V
			C213	1-136-161-00	FILM 0.047MF 5% 50V



Ref.No.	Part No.	Description			
C214	1-130-481-00	MYLAR	0.0068MF	5%	50V
C215	1-136-153-00	FILM	0.01MF	5%	50V
C216	1-124-902-00	(RX55,RX55ES)...ELECT	0.47MF	20%	50V
C216	1-124-252-00	(RX410).....ELECT	0.33MF	20%	50V
C217	1-123-875-11	(RX55,RX55ES)...ELECT	10MF	20%	50V
C217	1-124-927-11	(RX410).....ELECT	4.7MF	20%	50V
C218	1-124-768-11	ELECT	4.7MF	20%	50V
C219	1-124-927-11	ELECT	4.7MF	20%	50V
C220	1-136-156-00	FILM	0.018MF	5%	50V
C221	1-124-927-11	ELECT	4.7MF	20%	50V
C222	1-123-875-11	ELECT	10MF	20%	50V
C301	1-123-875-11	ELECT	10MF	20%	50V
C302	1-123-875-11	ELECT	10MF	20%	50V
C303	1-124-925-11	ELECT	2.2MF	20%	50V
C304	1-161-494-00	CERAMIC	0.022MF		25V
C305	1-124-963-11	ELECT	33MF	20%	16V
C306	1-124-499-11	ELECT	1MF	20%	50V
C307	1-124-499-11	(RX55,RX55ES)...ELECT	1MF	20%	50V
C501	1-126-176-11	ELECT	220MF	20%	10V
C701	1-124-887-00	ELECT	3300MF	20%	16V
C702	1-124-887-00	ELECT	3300MF	20%	16V
C703	1-124-472-11	ELECT	470MF	20%	10V
C704	1-124-472-11	ELECT	470MF	20%	10V
C705	1-124-472-11	ELECT	470MF	20%	6.3V
C706	1-123-875-11	ELECT	10MF	20%	50V
C707	1-124-925-11	ELECT	2.2MF	20%	50V
C708	1-124-122-11	(RX55,RX55ES)...ELECT	100MF	20%	50V
C709	1-124-122-11	(RX55,RX55ES)...ELECT	100MF	20%	50V
C710	1-124-120-11	ELECT	220MF	20%	16V
C901	1-161-744-00	CAP, CERAMIC	10000PF	FZ	
CF501	1-577-082-11	VIBRATOR, CERAMIC	(4MHZ)		
CNP11	*1-506-615-11	PIN, CONNECTOR	9P		
CNP12	*1-564-337-00	(RX410).....PIN, CONNECTOR	3P		
CNP12	*1-564-339-61	(RX55,RX55ES)...PIN, CONNECTOR	5P		
CNP13	*1-564-707-11	PIN, CONNECTOR (SMALL TYPE)	5P		
CNP14	*1-564-704-11	(RX55,RX55ES)...PIN, CONNECTOR	(SMALL TYPE) 2P		
CNP21	*1-565-344-11	PIN, CONNECTOR (PC BOARD)	8P		
CNP22	*1-565-347-11	SOCKET, CONNECTOR (PC BOARD)	8P		
CNP81	*1-564-709-11	PIN, CONNECTOR (SMALL TYPE)	7P		
CNP82	*1-564-339-00	PIN, CONNECTOR	5P		
CNP83	*1-564-338-00	PIN, CONNECTOR	4P		
CNP505*	1-564-506-11	(RX410).....PLUG, CONNECTOR	3P		
CNP505*	1-564-510-11	(RX55,RX55ES)...PLUG, CONNECTOR	7P		
D11	8-719-940-76	DIODE	1SS132		
D81	8-719-940-76	DIODE	1SS132		
D101	8-719-940-76	DIODE	1SS132		
D201	8-719-940-76	DIODE	1SS132		
D301	8-719-010-34	DIODE	UZ-4.7BSC		
D501	8-719-301-38	LED	SEL2210S-C		
D502	8-719-301-60	LED	SEL2910A-C		
D503	8-719-301-43	LED	SEL2410E-C		

<p><b>Note:</b> The components identified by mark <math>\Delta</math> or dotted line with mark <math>\Delta</math> are critical for safety. Replace only with part number specified.</p>	<p><b>Note:</b> Les composants identifiés par une marque <math>\Delta</math> sont critiques pour la sécurité. Ne les remplacer que par une pièce portant le numéro spécifié.</p>
--	--

Ref.No.	Part No.	Description			
D504	8-719-301-60	LED	SEL2910A-C		
D505	8-719-301-60	LED	SEL2910A-C		
D506	8-719-200-77	DIODE	10E2N		
D507	8-719-302-52	(RX55,RX55ES)...LED	SEL1410E		
D507	8-719-304-38	(RX410).....DIODE	SEL4414E-D		
D508	8-719-302-52	(RX55,RX55ES)...LED	SEL1410E		
D508	8-719-304-38	(RX410).....DIODE	SEL4414E-D		
D509	8-719-302-52	(RX55,RX55ES)...LED	SEL1410E		
D509	8-719-304-38	(RX410).....DIODE	SEL4414E-D		
D510	8-719-304-38	(RX410)...DIODE	SEL4414E-D		
D511	8-719-304-38	(RX410)...DIODE	SEL4414E-D		
D512	8-719-304-38	(RX410)...DIODE	SEL4414E-D		
D513	8-719-304-38	(RX410)...DIODE	SEL4414E-D		
D514	8-719-304-32	(RX410)...DIODE	SEL4214S		
D515	8-719-304-32	(RX410)...DIODE	SEL4214S		
D516	8-719-304-32	(RX410)...DIODE	SEL4214S		
D517	8-719-304-38	(RX410)...DIODE	SEL4414E-D		
D518	8-719-304-38	(RX410)...DIODE	SEL4414E-D		
D519	8-719-304-38	(RX410)...DIODE	SEL4414E-D		
D520	8-719-304-38	(RX410)...DIODE	SEL4414E-D		
D521	8-719-304-32	(RX410)...DIODE	SEL4214S		
D522	8-719-304-32	(RX410)...DIODE	SEL4214S		
D523	8-719-304-32	(RX410)...DIODE	SEL4214S		
D524	8-719-940-76	DIODE	1SS132		
D525	8-719-940-76	DIODE	1SS132		
D526	8-719-940-76	DIODE	1SS132		
D527	8-719-940-76	DIODE	1SS132		
D528	8-719-940-76	DIODE	1SS132		
D529	8-719-940-76	(RX410)...DIODE	1SS132		
D530	8-719-940-76	(RX410)...DIODE	1SS132		
D531	8-719-940-76	(RX410)...DIODE	1SS132		
D532	8-719-940-76	(RX410)...DIODE	1SS132		
D533	8-719-940-76	(RX55,RX55ES)...DIODE	1SS132		
D534	8-719-940-76	DIODE	1SS132		
D535	8-719-940-76	DIODE	1SS132		
D701	8-719-940-76	DIODE	1SS132		
D702	8-719-940-76	DIODE	1SS132		
D703	8-719-200-77	DIODE	10E2N		
D704	8-719-200-77	DIODE	10E2N		
D705	8-719-200-77	DIODE	10E2N		
D706	8-719-200-77	DIODE	10E2N		
D707	8-719-940-76	DIODE	1SS132		
D708	8-719-200-77	(RX55,RX55ES)...DIODE	10E2N		
D709	8-719-000-96	(RX55,RX55ES)...DIODE	UZL-7H2		
D710	8-719-934-23	(RX55,RX55ES)...DIODE	HZS30-3L		
D712	8-719-210-77	DIODE	10E2N		
D713	1-807-913-21	DIODE	11EQS04		
D714	1-807-913-21	DIODE	11EQS04		
D715	1-807-913-21	(RX55,RX55ES)...DIODE	11EQS04		
FL501	1-519-493-11	(RX55,RX55ES)...INDICATOR TUBE,	FLUORESCENT		
IC21	8-759-133-90	IC	UPC339C		
IC81	8-759-111-44	IC	UPC4570C-1		
IC91	8-759-106-56	IC	UPC1297CA		
IC301	8-752-018-70	IC	CX20187		
IC302	8-759-600-02	IC	M5218L		
IC303	8-759-600-02	IC	M5218L		

SEE ADDITIONAL  
SEE INFORMATION

Ref.No.	Part No.	Description
IC304	8-759-945-58	IC RC4558P
IC305	8-752-033-61	IC CXA1198AP
IC306	8-759-240-52	IC TC14052BP
IC501	8-759-633-24	IC M50940-135SP
IC502	8-741-161-00	IC SBX1610-51
IC701	8-759-604-29	IC M5F7805
IC702	8-759-604-86	IC M5F7807
IC703	8-759-604-90	IC M5F7907
J301	1-565-258-11	JACK, PIN 4P (LINE IN/OUT)
J302	1-507-796-71	JACK (MICROPHONE)
J303	1-507-797-21	JACK, LARGE TYPE (HEADPHONES)
L41	1-410-780-11	INDUCTOR 27MMH
L61	1-410-780-11	INDUCTOR 27MMH
LPF101	1-236-475-11	FILTER, LOW PASS
LPF201	1-236-475-11	FILTER, LOW PASS
PM901	1-454-456-11	SOLENOID, PLUNGER
Q11	8-729-173-38	TRANSISTOR 2SA733
Q12	8-719-939-23	PHOTO TRANSISTOR GP2S09-C
Q21	8-729-806-20	TRANSISTOR 2SA1345
Q81	8-729-801-83	TRANSISTOR 2SB1013
Q82	8-729-101-93	(RX410).....TRANSISTOR 2SC945L
Q82	8-729-119-78	(RX55,RX55ES)...TRANSISTOR 2SC2785
Q83	8-729-101-93	(RX410).....TRANSISTOR 2SC945L
Q83	8-729-119-78	(RX55,RX55ES)...TRANSISTOR 2SC2785
Q101	8-729-119-78	(RX55,RX55ES)...TRANSISTOR 2SC2785
Q102	8-729-119-78	(RX410)...TRANSISTOR 2SC2785
Q103	8-729-119-78	TRANSISTOR 2SC2785
Q104	8-729-900-80	TRANSISTOR DTC114ES
Q105	8-729-900-80	TRANSISTOR DTC114ES
Q201	8-729-119-78	(RX55,RX55ES)...TRANSISTOR 2SC2785
Q202	8-729-119-78	TRANSISTOR 2SC2785
Q203	8-729-119-78	TRANSISTOR 2SC2785
Q204	8-729-900-80	TRANSISTOR DTC114ES
Q205	8-729-900-80	TRANSISTOR DTC114ES
Q301	8-729-900-61	TRANSISTOR DTA114ES
Q302	8-729-900-61	TRANSISTOR DTA114ES
Q303	8-729-900-61	TRANSISTOR DTA114ES
Q304	8-729-900-61	TRANSISTOR DTA114ES
Q305	8-729-900-61	TRANSISTOR DTA114ES
Q306	8-729-801-93	TRANSISTOR 2SD1387
Q307	8-729-900-65	TRANSISTOR DTA144ES
Q308	8-729-900-65	TRANSISTOR DTA144ES
Q309	8-729-173-38	TRANSISTOR 2SA733
Q501	8-729-900-61	TRANSISTOR DTA114ES
Q502	8-729-900-61	TRANSISTOR DTA114ES
Q503	8-729-900-61	TRANSISTOR DTA114ES
Q504	8-729-900-61	TRANSISTOR DTA114ES
Q505	8-729-900-61	TRANSISTOR DTA114ES
Q506	8-729-900-63	TRANSISTOR DTA124ES
Q507	8-729-900-61	TRANSISTOR DTA114ES
Q508	8-729-801-93	TRANSISTOR 2SD1387
Q509	8-729-801-83	TRANSISTOR 2SB1013
Q510	8-729-900-80	TRANSISTOR DTC114ES
Q511	8-729-900-80	TRANSISTOR DTC114ES
Q512	8-729-900-80	TRANSISTOR DTC114ES
Q701	8-729-118-01	(RX55,RX55ES)...TRANSISTOR 2SB1116

Ref.No.	Part No.	Description			
R11	1-247-834-11	CARBON	1.3K	5%	1/4W
R12	1-249-414-11	CARBON	560	5%	1/4W
R13	1-247-818-11	CARBON	300	5%	1/4W
R14	1-249-408-11	CARBON	180	5%	1/4W
R17	1-249-437-11	CARBON	47K	5%	1/4W
R18	1-249-437-11	CARBON	47K	5%	1/4W
R21	1-249-425-11	CARBON	4.7K	5%	1/4W
R22	1-249-421-11	CARBON	2.2K	5%	1/4W
R23	1-249-421-11	CARBON	2.2K	5%	1/4W
R24	1-249-423-11	CARBON	3.3K	5%	1/4W
R25	1-249-429-11	CARBON	10K	5%	1/4W
R26	1-249-430-11	(RX410).....CARBON	12K	5%	1/4W
R26	1-249-431-11	(RX55,RX55ES)...CARBON	15K	5%	1/4W
R27	1-247-838-00	(RX410).....CARBON	2K	5%	1/4W
R27	1-249-425-11	(RX55,RX55ES)...CARBON	4.7K	5%	1/4W
R28	1-249-419-11	(RX410).....CARBON	1.5K	5%	1/4W
R28	1-249-425-11	(RX55,RX55ES)...CARBON	4.7K	5%	1/4W
R29	1-249-420-11	(RX55,RX55ES)...CARBON	1.8K	5%	1/4W
R41	1-247-881-00	(RX410).....CARBON	120K	5%	1/4W
R41	1-249-435-11	(RX55,RX55ES)...CARBON	33K	5%	1/4W
R42	1-249-404-00	(RX55,RX55ES)...CARBON	82	5%	1/4W
R42	1-249-405-11	(RX410).....CARBON	100	5%	1/4W
R43	1-247-882-11	CARBON	130K	5%	1/4W
R44	1-249-426-11	CARBON	5.6K	5%	1/4W
R45	1-249-428-11	(RX55,RX55ES)...CARBON	8.2K	5%	1/4W
R45	1-249-430-11	(RX410).....CARBON	12K	5%	1/4W
R51	1-249-434-11	(RX410).....CARBON	27K	5%	1/4W
R51	1-249-435-11	(RX55,RX55ES)...CARBON	33K	5%	1/4W
R52	1-249-393-11	CARBON	10	5%	1/4W
R53	1-247-883-00	CARBON	150K	5%	1/4W
R54	1-249-429-11	(RX55,RX55ES)...CARBON	10K	5%	1/4W
R54	1-249-433-11	(RX410).....CARBON	22K	5%	1/4W
R61	1-247-881-00	(RX410).....CARBON	120K	5%	1/4W
R61	1-249-435-11	(RX55,RX55ES)...CARBON	33K	5%	1/4W
R62	1-249-404-00	(RX55,RX55ES)...CARBON	82	5%	1/4W
R62	1-249-405-11	(RX410).....CARBON	100	5%	1/4W
R63	1-247-882-11	CARBON	130K	5%	1/4W
R64	1-249-426-11	CARBON	5.6K	5%	1/4W
R65	1-249-428-11	(RX55,RX55ES)...CARBON	8.2K	5%	1/4W
R65	1-249-430-11	(RX410).....CARBON	12K	5%	1/4W
R71	1-249-434-11	(RX410).....CARBON	27K	5%	1/4W
R71	1-249-435-11	(RX55,RX55ES)...CARBON	33K	5%	1/4W
R72	1-249-393-11	CARBON	10	5%	1/4W
R73	1-247-883-00	CARBON	150K	5%	1/4W
R74	1-249-429-11	(RX55,RX55ES)...CARBON	10K	5%	1/4W
R74	1-249-433-11	(RX410).....CARBON	22K	5%	1/4W
R81	1-249-409-11	CARBON	220	5%	1/4W
R82	1-249-409-11	CARBON	220	5%	1/4W
R84	1-212-849-00	FUSIBLE	4.7	5%	1/4W F
R85	1-249-437-11	CARBON	47K	5%	1/4W
R86	1-249-437-11	CARBON	47K	5%	1/4W
R87	1-249-429-11	CARBON	10K	5%	1/4W

# TC-RX55/RX55ES/RX410

Ref.No.	Part No.	Description				
R88	1-249-429-11	CARBON	10K	5%	1/4W	
R101	1-249-417-11	CARBON	1K	5%	1/4W	
R102	1-249-435-11	CARBON	33K	5%	1/4W	
R103	1-249-429-11	CARBON	10K	5%	1/4W	
R104	1-249-411-11	CARBON	330	5%	1/4W	
R105	1-249-434-11	CARBON	27K	5%	1/4W	
R106	1-249-437-11	CARBON	47K	5%	1/4W	
R107	1-249-429-11	(RX55,RX55ES)...CARBON	10K	5%	1/4W	
R108	1-249-417-11	CARBON	1K	5%	1/4W	
R109	1-249-441-11	(RX55,RX55ES)...CARBON	100K	5%	1/4W	
R110	1-249-423-11	CARBON	3.3K	5%	1/4W	
R111	1-249-428-11	CARBON	8.2K	5%	1/4W	
R112	1-247-840-00	CARBON	2.4K	5%	1/4W	
R113	1-247-846-11	CARBON	4.3K	5%	1/4W	
R114	1-247-822-11	CARBON	430	5%	1/4W	
R115	1-249-427-11	CARBON	6.8K	5%	1/4W	
R116	1-249-415-11	CARBON	680	5%	1/4W	
R117	1-249-426-11	(RX410).....CARBON	5.6K	5%	1/4W	
R117	1-249-427-11	(RX55,RX55ES)...CARBON	6.8K	5%	1/4W	
R118	1-249-421-11	(RX410).....CARBON	2.2K	5%	1/4W	
R118	1-249-425-11	(RX55,RX55ES)...CARBON	4.7K	5%	1/4W	
R119	1-249-425-11	(RX410).....CARBON	4.7K	5%	1/4W	
R119	1-249-429-11	(RX55,RX55ES)...CARBON	10K	5%	1/4W	
R120	1-249-433-11	CARBON	22K	5%	1/4W	
R121	1-249-421-11	CARBON	2.2K	5%	1/4W	
R122	1-249-421-11	CARBON	2.2K	5%	1/4W	
R123	1-249-421-11	CARBON	2.2K	5%	1/4W	
R124	1-249-429-11	CARBON	10K	5%	1/4W	
R125	1-247-840-00	CARBON	2.4K	5%	1/4W	
R126	1-249-409-11	CARBON	220	5%	1/4W	
R127	1-249-434-11	CARBON	27K	5%	1/4W	
R128	1-249-434-11	CARBON	27K	5%	1/4W	
R129	1-247-862-11	CARBON	20K	5%	1/4W	
R130	1-249-397-11	CARBON	22	5%	1/4W	
R131	1-249-424-11	CARBON	3.9K	5%	1/4W	
R132	1-247-887-00	CARBON	220K	5%	1/4W	
R133	1-249-424-11	CARBON	3.9K	5%	1/4W	
R134	1-249-412-11	CARBON	390	5%	1/4W	
R135	1-247-840-00	CARBON	2.4K	5%	1/4W	
R136	1-249-441-11	CARBON	100K	5%	1/4W	
R137	1-249-425-11	(RX55,RX55ES)...CARBON	4.7K	5%	1/4W	
R137	1-249-429-11	(RX410).....CARBON	10K	5%	1/4W	
R138	1-249-431-11	CARBON	15K	5%	1/4W	
R201	1-249-417-11	CARBON	1K	5%	1/4W	
R202	1-249-435-11	CARBON	33K	5%	1/4W	
R203	1-249-429-11	CARBON	10K	5%	1/4W	
R204	1-249-411-11	CARBON	330	5%	1/4W	
R205	1-249-434-11	CARBON	27K	5%	1/4W	
R206	1-249-437-11	CARBON	47K	5%	1/4W	
R207	1-249-429-11	(RX55,RX55ES)...CARBON	10K	5%	1/4W	
R208	1-249-417-11	CARBON	1K	5%	1/4W	
R209	1-249-441-11	(RX55,RX55ES)...CARBON	100K	5%	1/4W	
R210	1-249-423-11	CARBON	3.3K	5%	1/4W	
R211	1-249-428-11	CARBON	8.2K	5%	1/4W	
R212	1-247-840-00	CARBON	2.4K	5%	1/4W	
R213	1-247-846-11	CARBON	4.3K	5%	1/4W	
R214	1-247-822-11	CARBON	430	5%	1/4W	

Ref.No.	Part No.	Description				
R215	1-249-427-11	CARBON	6.8K	5%	1/4W	
R216	1-249-415-11	CARBON	680	5%	1/4W	
R217	1-249-426-11	(RX410).....CARBON	5.6K	5%	1/4W	
R217	1-249-427-11	(RX55,RX55ES)...CARBON	6.8K	5%	1/4W	
R218	1-249-421-11	(RX410).....CARBON	2.2K	5%	1/4W	
R218	1-249-425-11	(RX55,RX55ES)...CARBON	4.7K	5%	1/4W	
R219	1-249-425-11	(RX410).....CARBON	4.7K	5%	1/4W	
R219	1-249-429-11	(RX55,RX55ES)...CARBON	10K	5%	1/4W	
R220	1-249-433-11	CARBON	22K	5%	1/4W	
R221	1-249-421-11	CARBON	2.2K	5%	1/4W	
R222	1-249-421-11	CARBON	2.2K	5%	1/4W	
R223	1-249-421-11	CARBON	2.2K	5%	1/4W	
R224	1-249-429-11	CARBON	10K	5%	1/4W	
R225	1-247-840-00	CARBON	2.4K	5%	1/4W	
R226	1-249-409-11	CARBON	220	5%	1/4W	
R227	1-249-434-11	CARBON	27K	5%	1/4W	
R228	1-249-434-11	CARBON	27K	5%	1/4W	
R229	1-247-862-11	CARBON	20K	5%	1/4W	
R230	1-249-397-11	CARBON	22	5%	1/4W	
R231	1-249-424-11	CARBON	3.9K	5%	1/4W	
R232	1-247-887-00	CARBON	220K	5%	1/4W	
R233	1-249-424-11	CARBON	3.9K	5%	1/4W	
R234	1-249-412-11	CARBON	390	5%	1/4W	
R235	1-247-840-00	CARBON	2.4K	5%	1/4W	
R236	1-249-441-11	CARBON	100K	5%	1/4W	
R237	1-249-425-11	(RX55,RX55ES)...CARBON	4.7K	5%	1/4W	
R237	1-249-429-11	(RX410).....CARBON	10K	5%	1/4W	
R238	1-249-431-11	CARBON	15K	5%	1/4W	
R301	1-249-413-11	CARBON	470	5%	1/4W	
R302	1-249-413-11	CARBON	470	5%	1/4W	
R303	1-249-435-11	CARBON	33K	5%	1/4W	
R304	1-215-469-00	METAL	100K	1%	1/6W	
R305	1-249-429-11	(RX55,RX55ES)...CARBON	10K	5%	1/4W	
R306	1-249-435-11	CARBON	33K	5%	1/4W	
R307	1-249-429-11	CARBON	10K	5%	1/4W	
R308	1-247-864-11	CARBON	24K	5%	1/4W	
R309	1-247-881-00	(RX55,RX55ES)...CARBON	120K	5%	1/4W	
R309	1-249-438-11	(RX410).....CARBON	56K	5%	1/4W	
R310	1-249-437-11	(RX55,RX55ES)...CARBON	47K	5%	1/4W	
R310	1-249-440-11	(RX410).....CARBON	82K	5%	1/4W	
R311	1-247-882-11	(RX410).....CARBON	130K	5%	1/4W	
R311	1-247-883-00	(RX55,RX55ES)...CARBON	150K	5%	1/4W	
R312	1-249-438-11	(RX410).....CARBON	56K	5%	1/4W	
R312	1-249-440-11	(RX55,RX55ES)...CARBON	82K	5%	1/4W	
R313	1-249-435-11	(RX410).....CARBON	33K	5%	1/4W	
R313	1-249-436-11	(RX55,RX55ES)...CARBON	39K	5%	1/4W	
R314	1-247-870-11	(RX410).....CARBON	43K	5%	1/4W	
R314	1-249-435-11	(RX55,RX55ES)...CARBON	33K	5%	1/4W	
R315	1-247-883-00	(RX410).....CARBON	150K	5%	1/4W	
R315	1-247-891-00	(RX55,RX55ES)...CARBON	330K	5%	1/4W	
R316	1-247-878-00	(RX410).....CARBON	91K	5%	1/4W	
R316	1-249-438-11	(RX55,RX55ES)...CARBON	56K	5%	1/4W	
R317	1-247-881-00	CARBON	120K	5%	1/4W	

SEE PARTIAL

Ref.No.	Part No.	Description
R318	1-247-874-11	(RX410).....CARBON 62K 5% 1/4W
R318	1-249-441-11	(RX55,RX55ES)...CARBON 100K 5% 1/4W
R319	1-249-437-11	CARBON 47K 5% 1/4W
R320	1-247-874-11	(RX55,RX55ES)...CARBON 62K 5% 1/4W
R320	1-249-440-11	(RX410).....CARBON 82K 5% 1/4W
R321	1-247-887-00	(RX410).....CARBON 220K 5% 1/4W
R321	1-249-435-11	(RX55,RX55ES)...CARBON 33K 5% 1/4W
R322	1-247-881-00	(RX410).....CARBON 120K 5% 1/4W
R322	1-249-441-11	(RX55,RX55ES)...CARBON 100K 5% 1/4W
R323	1-249-438-11	(RX55,RX55ES)...CARBON 56K 5% 1/4W
R323	1-249-440-11	(RX410).....CARBON 82K 5% 1/4W
R324	1-249-434-11	CARBON 27K 5% 1/4W
R325	1-247-872-11	(RX55,RX55ES)...CARBON 51K 5% 1/4W
R325	1-249-438-11	(RX410).....CARBON 56K 5% 1/4W
R326	1-249-429-11	CARBON 10K 5% 1/4W
R327	1-249-437-11	CARBON 47K 5% 1/4W
R328	1-249-417-11	CARBON 1K 5% 1/4W
R329	1-249-413-11	CARBON 470 5% 1/4W
R330	1-249-417-11	CARBON 1K 5% 1/4W
R331	1-249-425-11	CARBON 4.7K 5% 1/4W
R332	1-249-429-11	CARBON 10K 5% 1/4W
R333	1-249-419-11	CARBON 1.5K 5% 1/4W
R334	1-249-425-11	CARBON 4.7K 5% 1/4W
R335	1-249-437-11	CARBON 47K 5% 1/4W
R336	1-249-428-11	CARBON 8.2K 5% 1/4W
R337	1-249-423-11	CARBON 3.3K 5% 1/4W
R338	1-247-840-00	CARBON 2.4K 5% 1/4W
R339	1-247-876-11	(RX410).....CARBON 75K 5% 1/4W
R339	1-249-439-11	(RX55,RX55ES)...CARBON 68K 5% 1/4W
R340	1-249-417-11	CARBON 1K 5% 1/4W
R341	1-249-413-11	CARBON 470 5% 1/4W
R501	1-249-409-11	CARBON 220 5% 1/4W
R502	1-249-412-11	CARBON 390 5% 1/4W
R503	1-249-420-11	CARBON 1.8K 5% 1/4W
R504	1-249-422-11	CARBON 2.7K 5% 1/4W
R505	1-249-428-11	CARBON 8.2K 5% 1/4W
R506	1-249-409-11	CARBON 220 5% 1/4W
R507	1-249-412-11	CARBON 390 5% 1/4W
R508	1-249-415-11	CARBON 680 5% 1/4W
R509	1-249-418-11	CARBON 1.2K 5% 1/4W
R510	1-249-422-11	CARBON 2.7K 5% 1/4W
R511	1-249-428-11	(RX55,RX55ES)...CARBON 8.2K 5% 1/4W
R512	1-249-417-11	CARBON 1K 5% 1/4W
R514	1-249-436-11	CARBON 39K 5% 1/4W
R513	1-249-425-11	CARBON(RX55,RX55ES)...4.7K 5% 1/4W
R515	1-249-436-11	CARBON 39K 5% 1/4W
R516	1-247-895-00	CARBON 470K 5% 1/4W
R517	1-247-895-00	CARBON 470K 5% 1/4W
R518	1-249-437-11	CARBON 47K 5% 1/4W
R519	1-249-412-11	CARBON 390 5% 1/4W
R520	1-249-410-11	CARBON 270 5% 1/4W
R521	1-249-409-11	CARBON 220 5% 1/4W
R522	1-249-411-11	CARBON 330 5% 1/4W
R523	1-249-411-11	CARBON 330 5% 1/4W
R524	1-249-437-11	CARBON 47K 5% 1/4W
R525	1-247-903-00	CARBON 1M 5% 1/4W
R526	1-249-417-11	CARBON 1K 5% 1/4W



Ref.No.	Part No.	Description
R527	1-249-433-11	CARBON 22K 5% 1/4W
R528	1-247-727-11	CARBON 10 5% 1/2W
R529	1-249-420-11	CARBON 1.8K 5% 1/4W
R530	1-249-433-11	CARBON 22K 5% 1/4W
R531	1-249-415-11	(RX410)...CARBON 680 5% 1/4W
R532	1-249-442-11	(RX410)...CARBON 510 5% 1/4W
R533	1-249-411-11	(RX410)...CARBON 330 5% 1/4W
R534	1-247-814-11	(RX410)...CARBON 200 5% 1/4W
R535	1-249-415-11	(RX410)...CARBON 680 5% 1/4W
R536	1-249-442-11	(RX410)...CARBON 510 5% 1/4W
R537	1-249-411-11	(RX410)...CARBON 330 5% 1/4W
R538	1-247-832-11	(RX410)...CARBON 1.1K 5% 1/4W
R539	1-247-830-11	(RX410)...CARBON 910 5% 1/4W
R540	1-247-826-00	(RX410)...CARBON 620 5% 1/4W
R541	1-247-832-11	(RX410)...CARBON 1.1K 5% 1/4W
R542	1-247-830-11	(RX410)...CARBON 910 5% 1/4W
R543	1-247-826-00	(RX410)...CARBON 620 5% 1/4W
R544	1-249-409-11	CARBON 220 5% 1/4W
R545	1-249-409-11	CARBON 220 5% 1/4W
R546	1-249-409-11	CARBON 220 5% 1/4W
R547	1-249-421-11	CARBON 2.2K 5% 1/4W
R548	1-249-421-11	CARBON 2.2K 5% 1/4W
R701	1-249-403-11	CARBON 68 5% 1/4W
R702	1-249-403-11	CARBON 68 5% 1/4W
R703	1-249-417-11	CARBON 1K 5% 1/4W
R704	1-249-441-11	CARBON 100K 5% 1/4W
R705	1-249-433-11	(RX55,RX55ES)...CARBON 62K 5% 1/4W
RV41	1-228-990-00	RES, ADJ, CARBON 1K
RV42	1-230-497-11	RES, ADJ, CARBON 22K
RV61	1-228-990-00	RES, ADJ, CARBON 1K
RV62	1-230-497-11	RES, ADJ, CARBON 22K
RV101	1-228-994-00	RES, ADJ, CARBON 10K
RV201	1-228-994-00	RES, ADJ, CARBON 10K
RV301	1-238-097-11	RES, VAR, CARBON 20K/20K(REC LEVEL)
RY81	1-515-614-11	RELAY
S11	1-571-281-21	SWITCH, LEAF (HALF DET)
S12	1-571-281-21	SWITCH, LEAF (REC PROOF (A))
S13	1-571-281-21	SWITCH, LEAF (REC PROOF (B))
S14	1-571-281-21	SWITCH, LEAF (CrO2)
S15	1-571-281-21	SWITCH, LEAF (METAL)
S501	1-554-303-21	SWITCH, KEY BOARD (■)
S502	1-554-303-21	SWITCH, KEY BOARD (▨)
S503	1-554-303-21	SWITCH, KEY BOARD (▶)
S504	1-554-303-21	SWITCH, KEY BOARD (◀)
S505	1-554-303-21	SWITCH, KEY BOARD (●)
S506	1-554-303-21	SWITCH, KEY BOARD (◀◀)
S507	1-554-303-21	SWITCH, KEY BOARD (▶▶)
S508	1-554-303-21	SWITCH, KEY BOARD (○)
S509	1-554-303-21	(RX55,RX55ES)...SWITCH, KEY BOARD (COUNTER RESET)
S510	1-554-303-21	(RX55,RX55ES)...SWITCH, KEY BOARD (COUNTER MEMORY)
S511	1-571-305-11	SWITCH, PUSH (1 KEY)(DIRECTION MODE)
S512	1-571-305-11	(RX55,RX55ES)...SWITCH, PUSH (1 KEY) (MPX FILTER)
S513	1-571-305-11	SWITCH, PUSH (1 KEY)(DOLBY B/C)

Ref.No.	Part No.	Description
S514	1-571-305-11	SWITCH, PUSH (1 KEY)(DOLBY NR)
S515	1-554-423-00	(RX55,RX55ES)...SWITCH, SLIDE (TIMER)
S901	△.1-553-318-71	SWITCH, PUSH (AC POWER)(1 KEY)
S902	1-571-028-11	(RX55,RX55ES)...SWITCH, LEAF (DIRECTION)
SPK101	1-235-186-00	ENCAPSULATED COMPONENT
SPK201	1-235-186-00	ENCAPSULATED COMPONENT
T51	1-433-335-11	TRANSFORMER, BIAS OSCILLATION
T71	1-433-335-11	TRANSFORMER, BIAS OSCILLATION
T81	1-433-336-11	TRANSFORMER, BIAS OSCILLATION
T901	△.1-449-596-11	(RX55ES,RX55:Canadian/E2) ...TRANSFORMER, POWER
T901	△.1-449-597-11	(RX55: AEP/UK/E3)...TRANSFORMER, POWER
T901	△.1-449-598-11	(RX410).....TRANSFORMER, POWER
TP83	*1-564-338-00	PIN, CONNECTOR 4P
TP91	*1-564-508-11	PLUG, CONNECTOR 5P

## ACCESSORY & PACKING MATERIAL

1-559-533-11	CORD, CONNECTION
*3-332-556-01	(RX55ES)...INDIVIDUAL CARTON
*3-332-556-51	(RX55).....INDIVIDUAL CARTON
*3-332-556-71	(RX410)....INDIVIDUAL CARTON
*3-349-005-01	CUSHION
*3-701-630-00	BAG, POLYETHYLENE
3-703-450-01	(US)...INSTRUCTION
3-750-181-21	(RX410).....MANUAL, INSTRUCTION (English)
3-750-181-31	(RX410:Canadian)...MANUAL, INSTRUCTION (French)
3-750-118-11	(RX55:Canadian/AE1/AE2/E2/E3) .....MANUAL, INSTRUCTION(English,French,Spanish)
3-750-118-21	(RX55ES).....MANUAL, INSTRUCTION(English)
3-750-118-41	(RX55: AE1/AE2/E3).....MANUAL, INSTRUCTION(German,Dutch,Swedish,Italian)
3-750-118-51	(RX55:West Germany)...MANUAL, INSTRUCTION (German)
3-750-118-61	(RX55:UK).....MANUAL, INSTRUCTION(English)

### Note:

The components identified by mark  or dotted line with mark  are critical for safety. Replace only with part number specified.

### Note:

Les composants identifiés par une marque  sont critiques pour la sécurité. Ne les remplacer que par une pièce portant le numéro spécifié.



# TC-RX55/RX55ES/RX410

## SONY<sup>®</sup> SERVICE MANUAL

*US Model*  
TC-RX55ES/RX410

*Canadian Model*  
TC-RX55/RX410

*AEP Model*

*UK Model*

*E Model*

TC-RX55

## SUPPLEMENT-1

Subject: Adjustment Item Addition

### Bias Consumption Current Adjustment

**Note:** Perform this adjustment before Record Bias Adjustment only when replacing head, IC91, or step-up transformers (T51, T71).

**Setting:**

REC LEVEL control: standard record  
(See service manual page 4.)

**Procedure:**

1. Set RV42 and RV62 to mechanical center.
2. Set blank tape (CS-412) and record on no-signal conditions.
3. Adjust T51 (L-CH), T71 (R-CH) so that the voltage between pin ③ - ⑤ (L-CH), pin ③ - ① (R-CH) of TP91 is minimum.
4. Perform Record Bias Adjustment and Record Level Adjustment.

**Adjustment Location:** HX PRO board

Bias consumption current adjustment

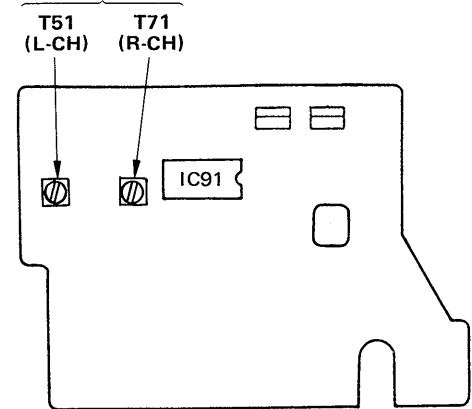

Schematic diagram and electrical parts list have been changed because of resistors value change.

Ref. No.	Former		New	
	Part No.	Description	Part No.	Description
R26	1-249-430-11	(RX410) ... CARBON 12K 5% 1/4W	1-249-433-11	(RX410) ... CARBON 22K 5% 1/4W
R27	1-247-838-00	(RX410) ... CARBON 2K 5% 1/4W	1-249-429-11	(RX410) ... CARBON 10K 5% 1/4W
R28	1-249-419-11	(RX410) ... CARBON 1.5K 5% 1/4W	1-249-428-11	(RX410) ... CARBON 8.2K 5% 1/4W
R53	1-247-883-00	CARBON 150K 5% 1/4W	1-247-883-00	(RX55, RX55ES) ... CARBON 150K 5% 1/4W
			1-247-887-11	(RX410) ... CARBON 220K 5% 1/4W
R54	1-249-433-11	(RX410) ... CARBON 22K 5% 1/4W	1-247-862-11	(RX410) ... CARBON 20K 5% 1/4W
R73	1-247-883-00	CARBON 150K 5% 1/4W	1-247-883-00	(RX55, RX55ES) ... CARBON 150K 5% 1/4W
			1-247-887-11	(RX410) ... CARBON 220K 5% 1/4W
R74	1-249-433-11	(RX410) ... CARBON 22K 5% 1/4W	1-247-862-11	(RX410) ... CARBON 20K 5% 1/4W
R318	1-247-874-11	(RX410) ... CARBON 62K 5% 1/4W	1-247-872-11	(RX410) ... CARBON 51K 5% 1/4W
R319	1-249-437-11	CARBON 47K 5% 1/4W	1-247-872-11	(RX410) ... CARBON 51K 5% 1/4W
			1-249-437-11	(RX55, RX55ES) ... CARBON 47K 5% 1/4W
R320	1-249-440-11	(RX410) ... CARBON 82K 5% 1/4W	1-247-876-11	(RX410) ... CARBON 75K 5% 1/4W

## CORRECTION



 : corrected portion

### Service Manual Page 1: SPECIFICATIONS

Frequency response

DOLBY NR OFF

TC-RX55/RX55ES:

- With TYPE IV cassette (Sony METAL-ES)
  - 20–20,000 Hz ( $\pm 3$  dB) (TC-RX55ES) 
  - 30–18,000 Hz ( $\pm 3$  dB) (TC-RX55) 
  - 30–15,000 Hz ( $\pm 3$  dB, OVU recording)
- With TYPE II cassette (Sony UX-S)
  - 30–17,000 Hz ( $\pm 3$  dB)
- With TYPE I cassette (Sony HF-S)
  - 30–15,000 Hz ( $\pm 3$  dB)

### Service Manual Page 14:

#### Schematic diagram's note addition

- Value of resistors and capacitors.  
no mark: TC-RX55/RX55ES  
( ): TC-RX410

### Service Manual Page 6: Adjustment Location

#### Record Bias Adjustment

HX PRO board

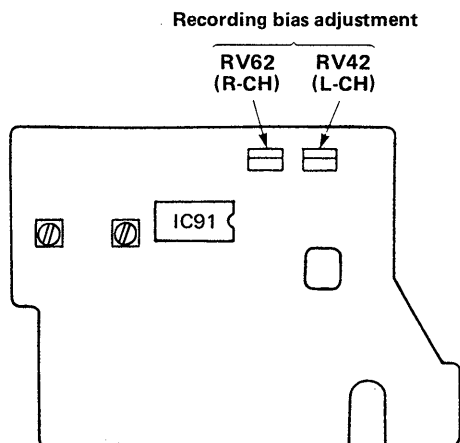

#### Record Level Adjustment

MAIN board

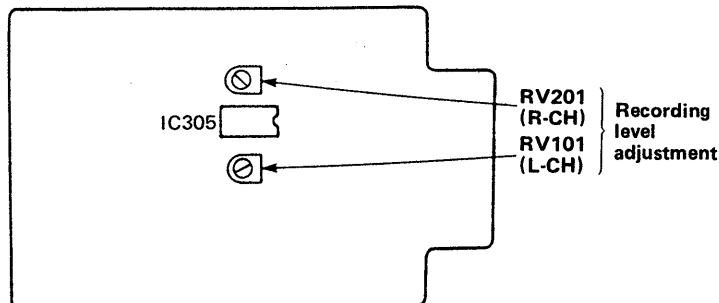

**Note:** Blank tape used in Record Bias Adjustment and Record Level Adjustment has been changed from CS-17 to CS-122.  
New type and old type blank tapes are shown in the following list.

#### Blank Tape

Type	Old type tape	New type tape	New type tape part No.
TYPE I	CS-17	CS-122	8-892-331-56
TYPE II	CS-26	CS-222	8-892-331-55
TYPE IV	CS-42	CS-412	8-892-324-39

### Service Manual Page 24: ACCESSORY & PACKING MATERIAL

INCORRECT		CORRECT	
*3-332-556-01	(RX55ES) . . . . . INDIVIDUAL CARTON	*3-332-556-61	(RX55ES) . . . . . INDIVIDUAL CARTON

# TC-RX55/RX55ES/RX410

**SONY®**  
**SERVICE MANUAL**

*US Model*  
TC-RX55ES/RX410

*Canadian Model*  
TC-RX55/RX410

*AEP Model*

*UK Model*

*E Model*

TC-RX55

## CORRECTION-1

Please correct your service manual.

Page 16

 : Additional part

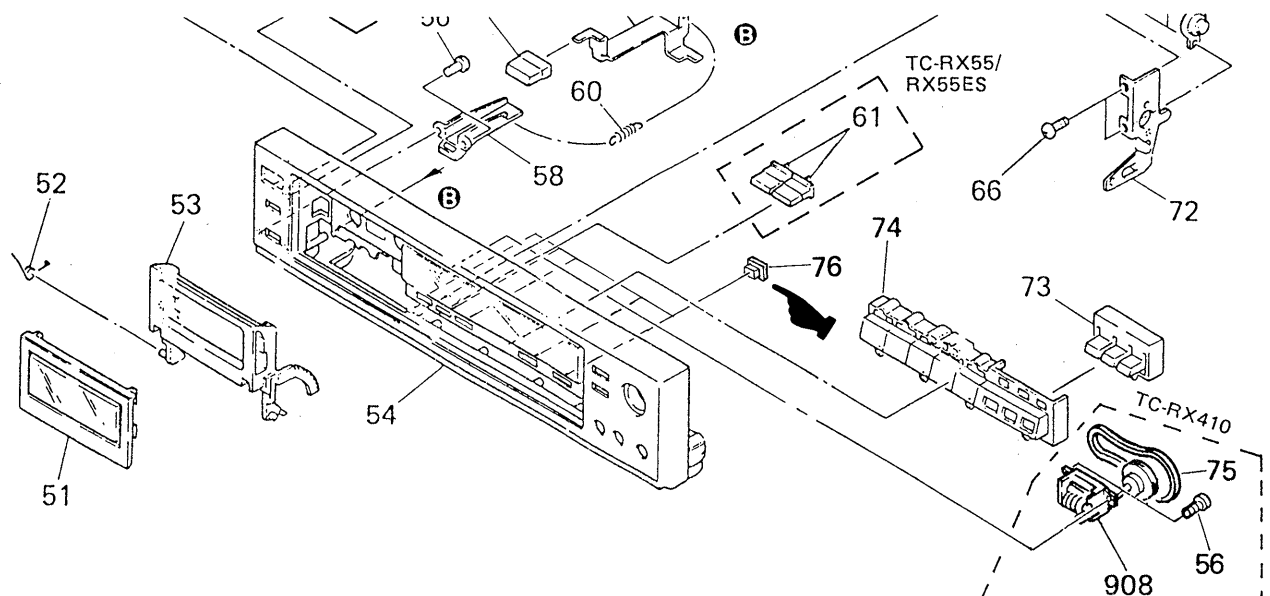

No.	Part No.	Description
76	3-340-195-02	INDICATOR