

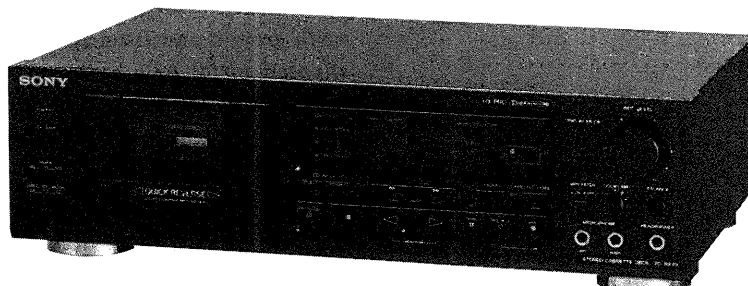

TC-RX70/RX70ES

SERVICE MANUAL

US Model
Canadian Model
UK Model
TC-RX70ES
AEP Model
TC-RX70



Dolby noise reduction manufactured under license from Dolby Laboratories Licensing Corporation. "DOLBY" and the double-D symbol  are trademarks of Dolby Laboratories Licensing Corporation.

SPECIFICATIONS

Model Name Using Similar Mechanism	New Mechanism
Tape Transport Mechanism Type	TCM-200D2

Recording system 4-track 2-channel stereo
Fast winding Approx. 90 sec. (with C-60 cassette)
Bias AC Bias
Signal-to-noise ratio (NAB, at peak level)

DOLBY NR switch	Cassette		
	OFF	B-TYPE ON	C-TYPE ON
Type IV (Sony METAL-ES)	59 dB	67 dB	74 dB
Type II (Sony UX-S)	58 dB	66 dB	73 dB
Type I (Sony HF-S)	56 dB	64 dB	71 dB

Total harmonic distortion 1.0 % (with Sony METAL-ES cassettes)

Frequency response
DOLBY NR OFF
• With Type IV cassette (Sony METAL-ES)
RX70ES : 20-20,000 Hz (± 3 dB)
RX70 : 25-19,000 Hz (± 3 dB)
30-15,000 Hz (± 3 dB, 0VU recording)
• With Type II cassette (Sony UX-S)
25-17,000 Hz (± 3 dB)
15-18,000 Hz
• With Type I cassette (Sony HF-S)
25-16,000 Hz (± 3 dB)
15-17,000 Hz

Wow and flutter 0.06% WRMS (NAB)
Inputs
Microphone inputs (phone jacks)
Sensitivity 0.25 mV (-70 dB)
For a low-impedance microphone
Line inputs (phono jacks)
Sensitivity 77.5 mV (-20 dB)
Input impedance 47k ohms

Outputs
Line outputs (phono jacks)
Output level of 0.44 V (-5 dB) at a load impedance of 47k ohms
Load impedance of over 10k ohms
Headphones output (stereo phone jack)
Output level of -28 dB at a load impedance of 8 ohms

General

Power requirements
RX70ES : 120 V AC, 60Hz (US, Canadian models)
240 V AC, 50Hz (UK model)
RX70 : 220 V AC, 50/60Hz (AEP model)

Power consumption

23 W

Dimensions Approx. 430 x 123 x 285 mm (w/h/d)
(17 x 4 $\frac{7}{8}$ x 11 $\frac{1}{4}$ inches)
including projecting parts and controls

Weight Approx. 4.6 kg (10 lbs 3 oz)

Supplied accessory
Connecting cord (2)

Optional accessory
Remote commander RM-J901

Design and specifications are subject to change without notice.

STEREO CASSETTE DECK
SONY[®]

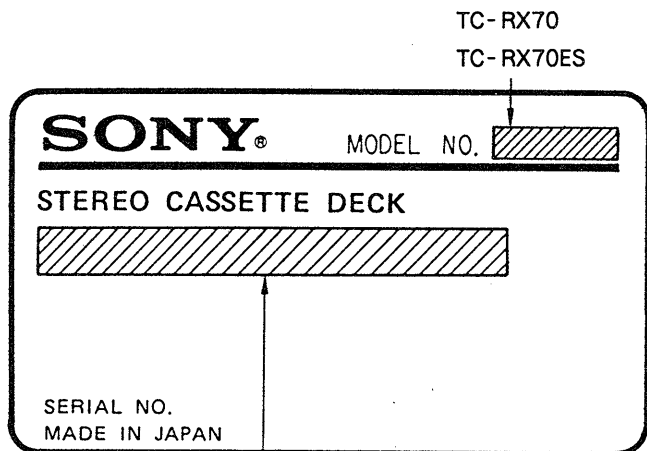

TABLE OF CONTENTS

Section	Title	Page
Specification		1
Model Identification		2
Safety Check-Out		2
1. GENERAL		3
2. DISASSEMBLY		4
3. ADJUSTMENTS		7
3-1. Mechanical Adjustment		7
3-2. Electrical Adjustment		7
4. DIAGRAMS		
4-1. Semiconductor Lead Layout		11
4-2. Circuit Boards Location		12
4-3. Printed Wiring Boards		13
4-4. Schematic Diagram		17
5. EXPLODED VIEWS		19
5-1. Front Panel Section		23
5-2. Chassis Section		24
5-3. Mechanism Section (TCM-200R2)		25
5-4. Mechanism Section (TCM-200R2)		26
6. ELECTRICAL PARTS LIST		27

MODEL IDENTIFICATION

— Specification Label —



US, Canadian Models : AC 120V 60Hz 23W
 UK Model : AC 240V ~ 50/60Hz
 AEP Model : AC 220V ~ 50/60Hz

SAFETY CHECK-OUT

After correcting the original service problem, perform the following safety check before releasing the set to the customer:

Check the antenna terminals, metal trim, "metallized" knobs, screws, and all other exposed metal parts for AC leakage. Check leakage as described below.

LEAKAGE TEST

The AC leakage from any exposed metal part to earth ground and from all exposed metal parts to any exposed metal part having a return to chassis, must not exceed 0.5 mA (500 microampers). Leakage current can be measured by any one of three methods.

1. A commercial leakage tester, such as the Simpson 229 or RCA WT-540A. Follow the manufacturers' instructions to use these instruments.
2. A battery-operated AC milliammeter. The Data Precision 245 digital multimeter is suitable for this job.
3. Measuring the voltage drop across a resistor by means of a VOM or battery-operated AC voltmeter. The "limit" indication is 0.75 V, so analog meters must have an accurate low-voltage scale. The Simpson 250 and Sanwa SH-63Trd are examples of a passive VOM that is suitable. Nearly all battery operated digital multimeters that have a 2V AC range are suitable. (See Fig. A)

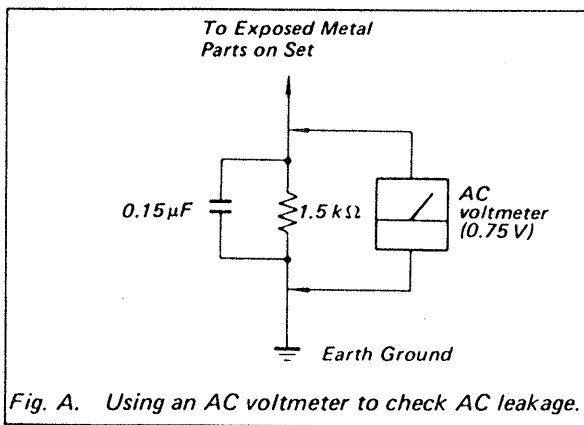

SAFETY-RELATED COMPONENT WARNING!!

COMPONENTS IDENTIFIED BY MARK Δ OR DOTTED LINE WITH MARK Δ ON THE SCHEMATIC DIAGRAMS AND IN THE PARTS LIST ARE CRITICAL TO SAFE OPERATION. REPLACE THESE COMPONENTS WITH SONY PARTS WHOSE PART NUMBERS APPEAR AS SHOWN IN THIS MANUAL OR IN SUPPLEMENTS PUBLISHED BY SONY.

ATTENTION AU COMPOSANT AYANT RAPPORT À LA SÉCURITÉ!

LES COMPOSANTS IDENTIFIÉS PAR UNE MARQUE Δ SUR LES DIAGRAMMES SCHÉMATIQUES ET LA LISTE DES PIÈCES SONT CRITIQUES POUR LA SÉCURITÉ DE FONCTIONNEMENT. NE REMPLACER CES COMPOSANTS QUE PAR DES PIÈCES SONY DONT LES NUMÉROS SONT DONNÉS DANS CE MANUEL OU DANS LES SUPPLÉMENTS PUBLIÉS PAR SONY.

SECTION 1 GENERAL

Identification of Front Panel Parts

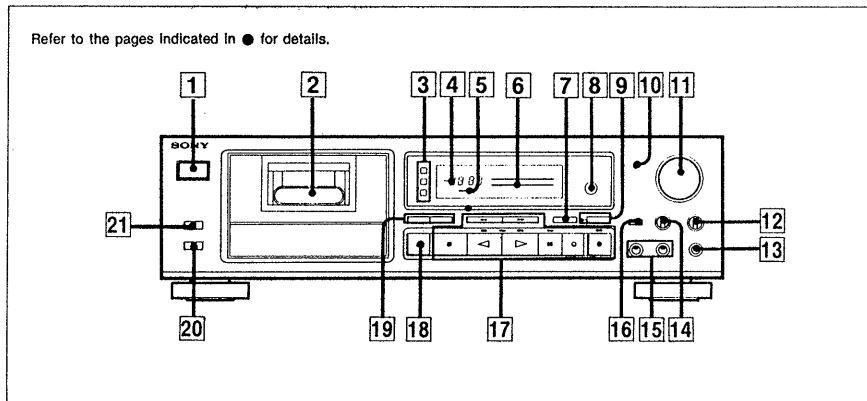

17 Tape operation buttons and direction mode, REC and PAUSE indicators

- ◀◀ (leftward fast winding) button
- ▶▶ (rightward fast winding) button
- ▶ (forward play) button
- ◀ (reverse play) button
- (stop) button
- ⏸ (pause) button
- REC MUTE (record muting) button
- REC (record) button

18 OPEN/CLOSE button

19 COUNTER RESET and MEMORY buttons

20 DIRECTION MODE switch

21 TIMER switch

1 POWER switch

2 Cassette holder

3 TAPE TYPE indicators



4 LINEAR COUNTER

5 MEMORY indicator

6 PEAK LEVEL METER

7 FADER button

8 Remote control sensor

- You can control this cassette deck remotely with:
- Any remote commander (supplied with a Sony amplifier or receiver) which is marked with the  logo and has cassette deck control capability.
 - An optional Sony remote commander with the  logo.

9 AUTO REC (automatic recording) LEVEL button and indicator

10 DISPLAY MODE button

11 REC LEVEL (recording level) control

12 BALANCE control

13 HEADPHONES jack (stereo phone jack)

14 DOLBY NR (Dolby noise reduction) switch

15 MICROPHONE jacks (phone jacks)

16 MPX FILTER button

Identification of Rear Panel Parts

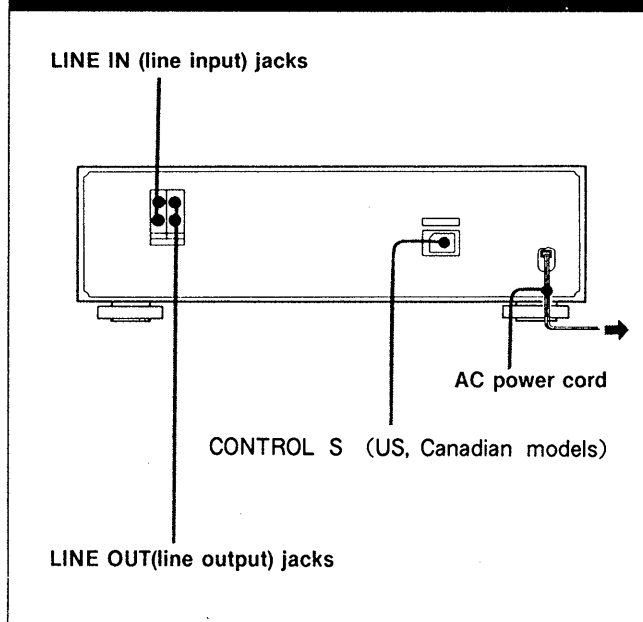

SECTION 2 DISASSEMBLY

Note: Follow the disassembly procedure
in the numerical order given.

Unscrew the four case attachment screws M3 × 8 and
remove the upper case.

MAIN BOARD

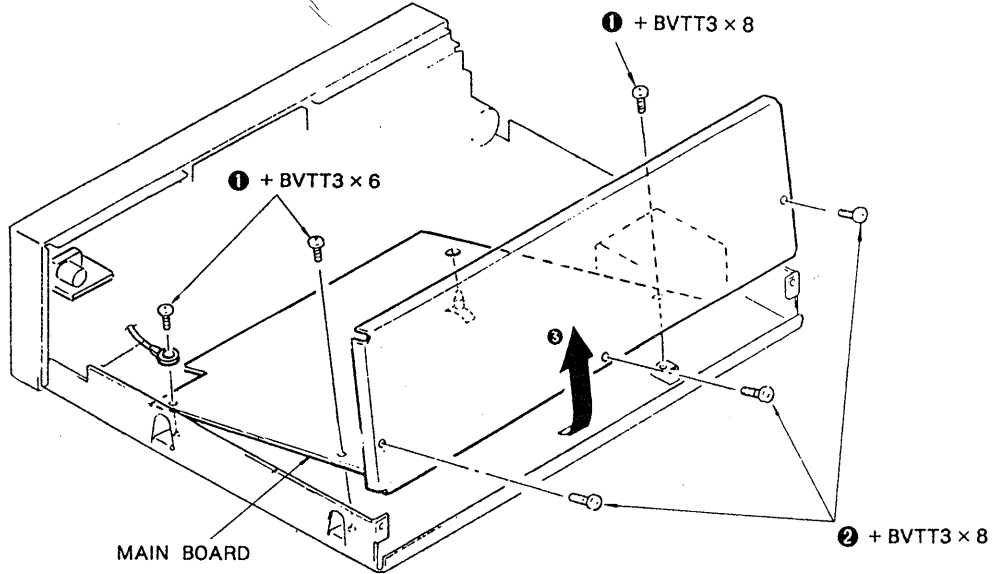

MECHANISM

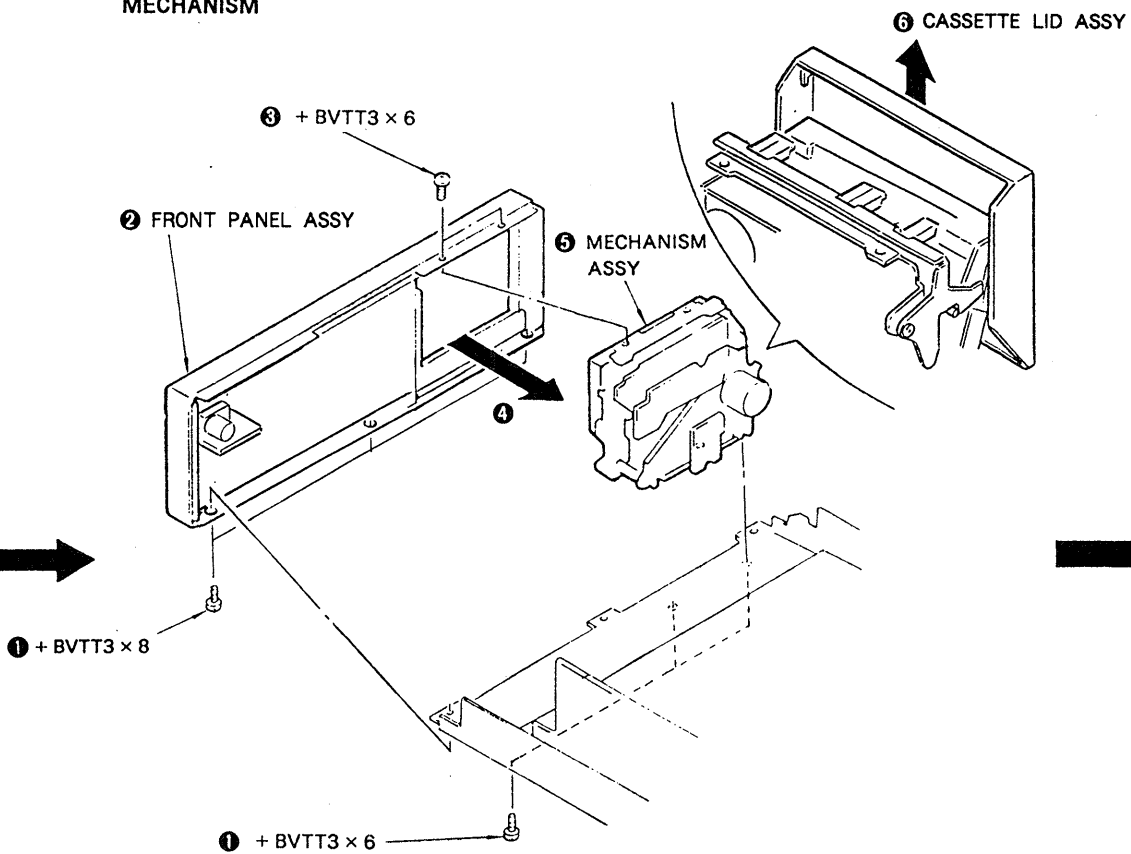

CASSETTE HOLDER

③ Push LEVER (LIFTER) in the direction of arrow and remove CASSETTE HOLDER.

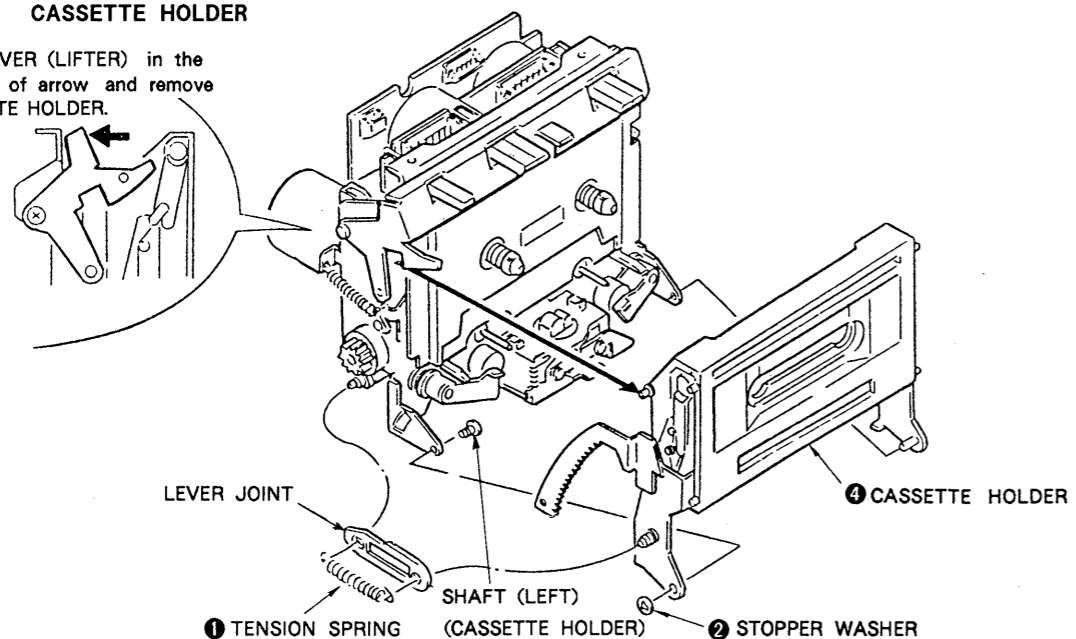

ORNAMENTAL PLATE

② Push LEVER (LIFTER) in the direction of arrow and remove ORNAMENTAL PLATE.

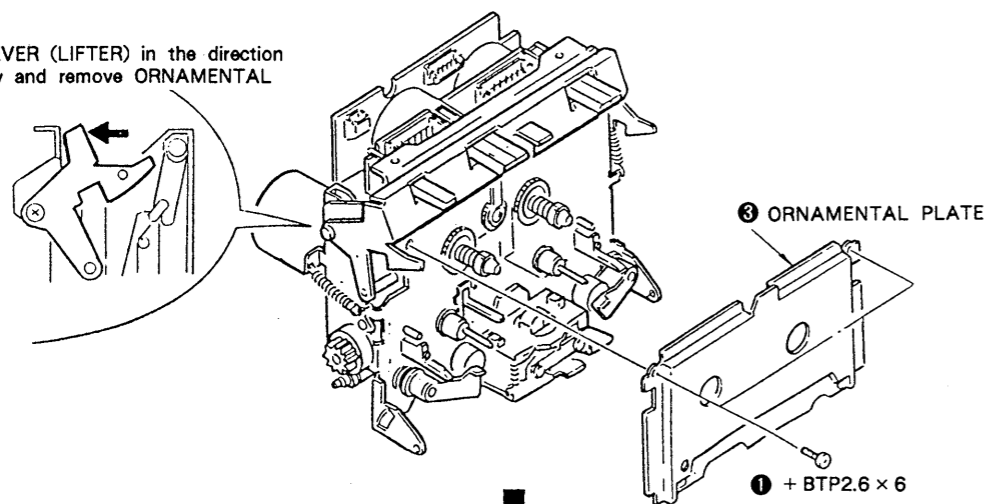

PINCH LEVER/HEAD

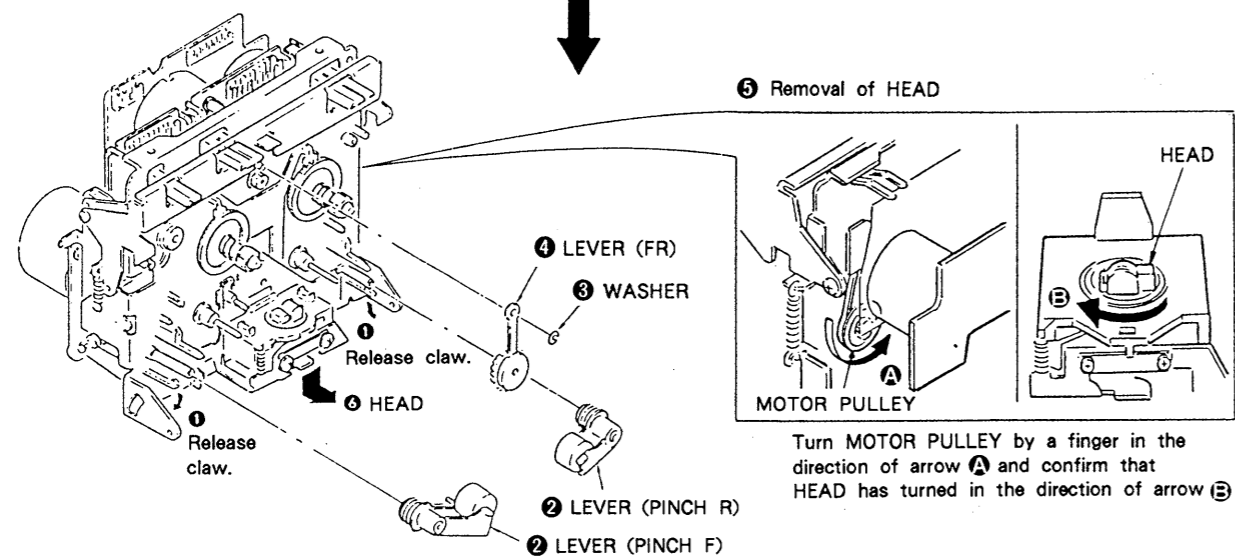

CAPSTAN MOTOR/FLYWHEEL

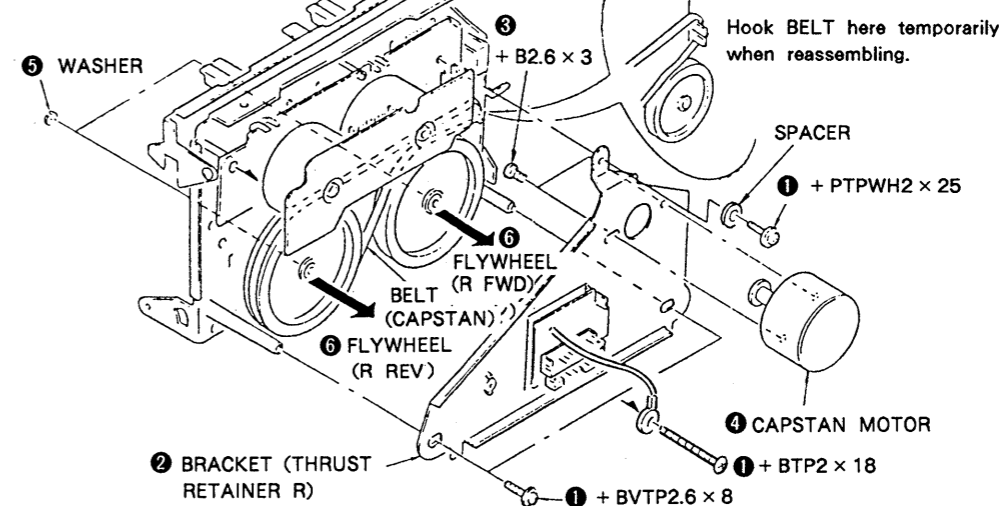

REEL and ASSIST MOTORS

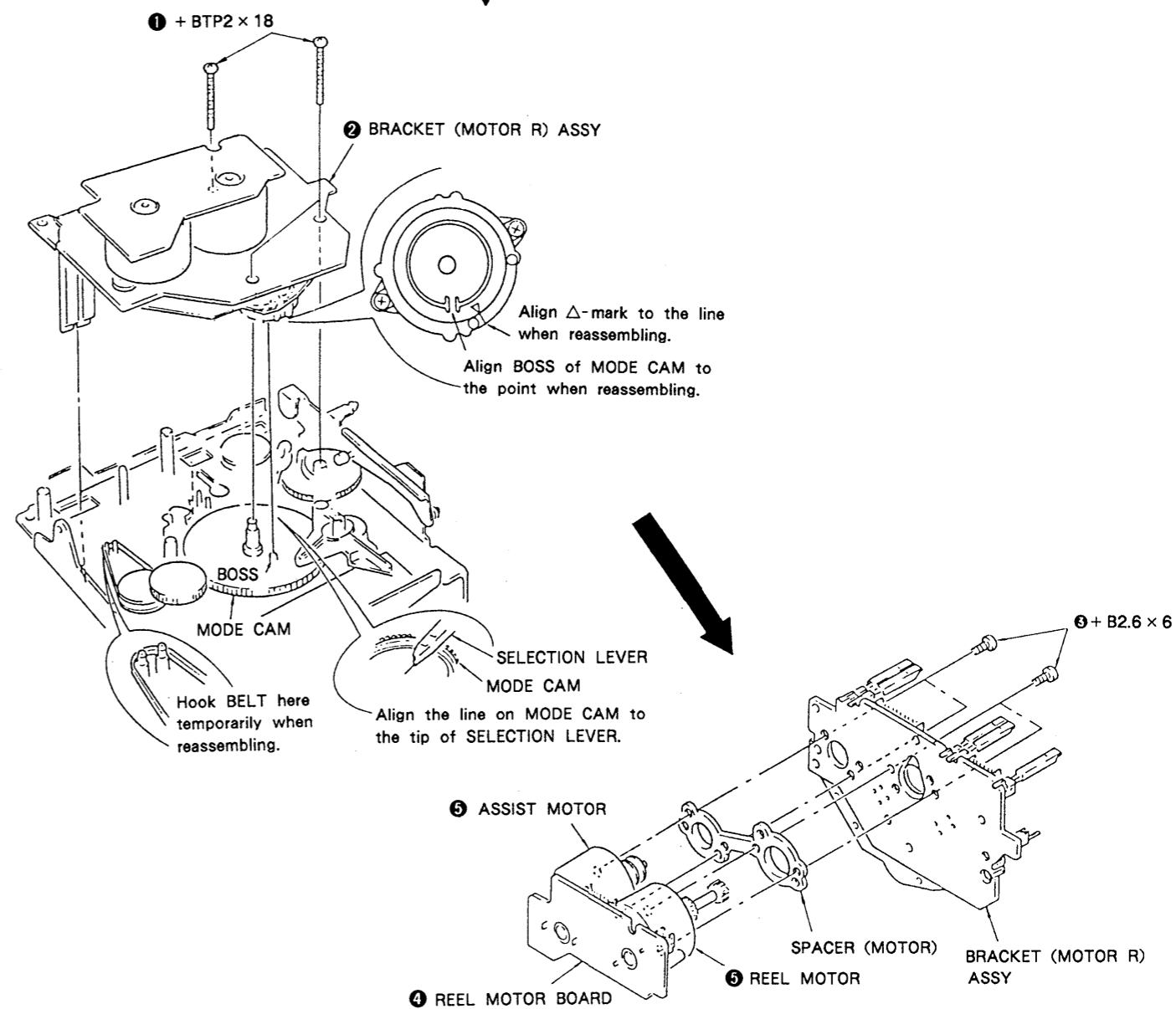

SECTION 3 ADJUSTMENTS

3.1. MECHANICAL ADJUSTMENTS

PRECAUTION

1. Clean the following parts with a denatured-alcohol-moistened swab :

record/playback head	pinch roller
erase head	rubber belts
capstan	idler
2. Demagnetize the record/playback head with a head demagnetizer.
3. Do not use a magnetized screwdriver for the adjustments.
4. After the adjustments, apply suitable locking compound to the parts adjusted.

TORQUE MEASUREMENT

Torque	Torque meter	Meter reading
FWD	CQ-102C	30 - 60g·cm (0.42 - 0.83oz·inch)
FWD Back tention	CQ-102C	1 - 5g·cm (0.014 - 0.069oz·inch)
REV	CQ-102RB	30 - 60g·cm (0.42 - 0.83oz·inch)
REV Back tention	CQ-102RB	1 - 5g·cm (0.014 - 0.069oz·inch)
FF, REW	CQ-201B	70 - 120g·cm (0.98 - 1.66oz·inch)

3.2. ELECTRICAL ADJUSTMENT

Note: The adjustment should be performed in the order given in the service manual. As a rule, adjustments about playback should be performed before those about recording. The adjustments should be performed for both L-CH and R-CH.

- Switches and controls should be set as follows unless otherwise specified.

DOLBY NR switch : OFF
DIRECTION switch : \rightleftarrows

- Standard Record :

Deliver the standard input signal level to the input jack and set the REC LEVEL control to obtain the standard output signal level.

—Record Mode—

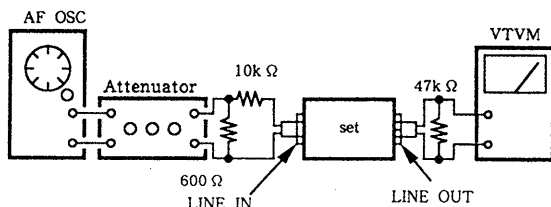

Standard Input Level

input terminal	LINE IN
source impedance	10k Ω
input level	0.25V (-10dB)

Standard Output Level

output terminal	LINE OUT
load impedance	47k Ω
output level	0.44V (-5dB)

Test Tape

Type	Signal	Used for
P-4-A100	10kHz, -10dB	Azimuth Adjustment
P-4-L300	315Hz, 0dB	PB Level Adjustment
WS-48B	3kHz, 0dB	Tape Speed Adjustment

Test Mode

The set will get into test mode by shorting the pins of TP801 (TEST) on Main board before turning the power on.

Record/Playback Head Azimuth Adjustment

Procedure :

1. Mode : FWD playback

Test tape
P-4-A100
(10kHz, -10dB)

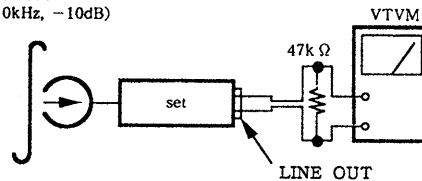

2. Turn the adjustment screw for the maximum output levels. If these levels do not match, turn the adjustment screw until both of output levels match together within 1dB.

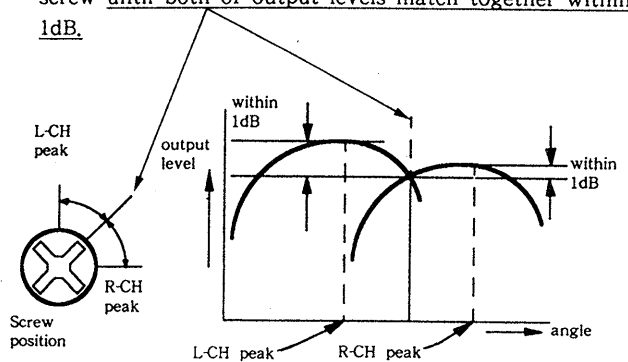

3. Phase Check
Mode : playback

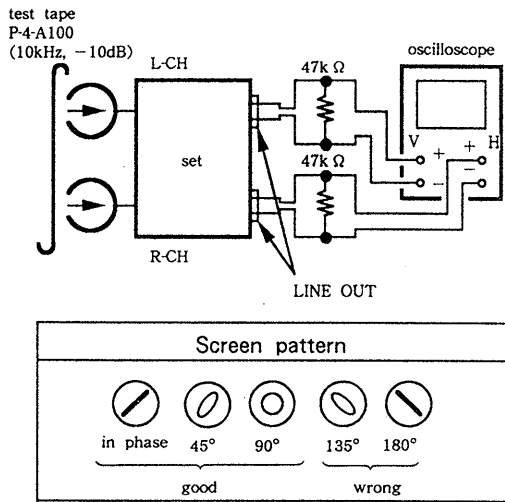

4. Set in the REV mode and repeat the step 1-3.
5. After the adjustment, lock the screws with locking compound.

Adjustment Location : Record/Playback head

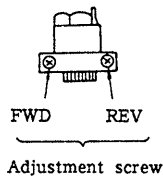

Tape Speed Adjustment

Setting :
test pin TP801 : short

Procedure :
Mode : playback

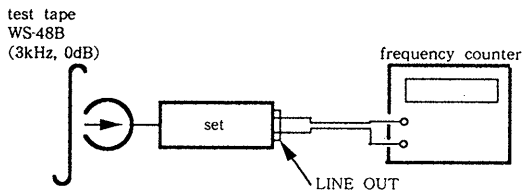

1. Set to FWD playback mode.
2. Adjust motor rear side (variable resistor) so that the frequency counter reading becomes $3,000 \pm 15\text{Hz}$.

Frequency difference between FWD and REV modes should be within 5%.

Adjustment Location :
motor rear side

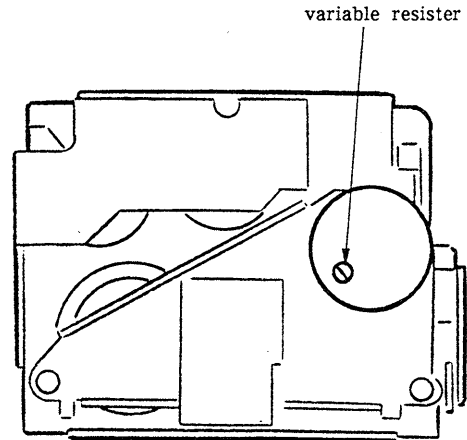

Playback Level Adjustment

Procedure :
Mode : playback

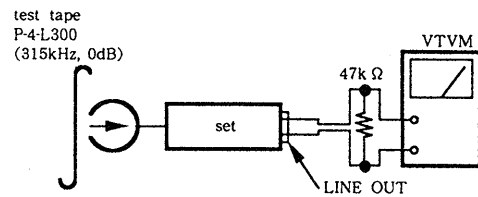

Adjust RV101 (L-ch) and RV301 (R-ch) so that the reading on VTVM meets the adjustment limits below.

Adjustment Limits :

LINE OUT level : $-5 \pm 0.5\text{dB}$ (0.41-0.46V)

Level difference between channels : less than 0.5dB

Check that the LINE OUT level does not change even if Playback and Stop operation is repeated several times.

Adjustment Location : Main board

Bias Current Adjustment

Procedure :

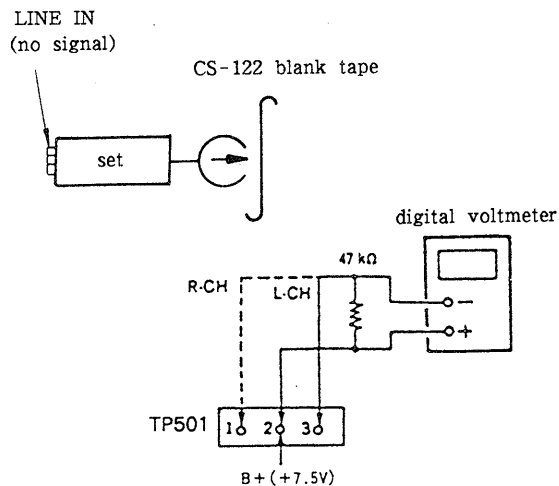

1. Set RV103 and RV303 to mechanical center and turn the set recording mode.
2. Connect digital voltmeter as shown by the following table.
3. Adjust the following transformers for the minimum readings on the digital voltmeter.

	Mesurement Point	Adjustment Part	Value
L-ch	① and ②, TP501	T101	not more than 80mV
R-ch	② and ③, TP501	T301	

Adjustment Location : Main board

Record Bias Adjustment

Setting :

REC LEVEL control : Standard Record (See page 7.)

test pin TP801 : short

Procedure :

1. Mode : record

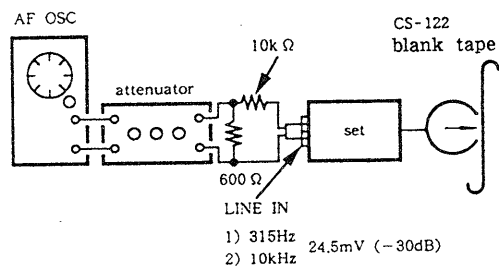

2. Mode : playback

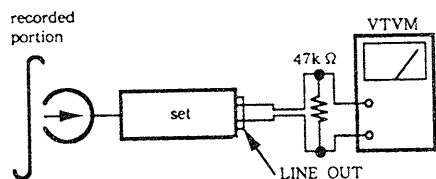

Playback the signal recorded in step 1.

Confirm that the 10kHz playback output is $0 \pm 0.5\text{dB}$ relative to the 315Hz output. If necessary, adjust RV103 (L-ch) and RV303 (R-ch) for repeat the steps given above.

Adjustment Location : Main board

Record Level Adjustment

Setting :

REC LEVEL control : Standard Record (See page 7.)

test pin TP801 : short

Procedure :

1. Mode : record

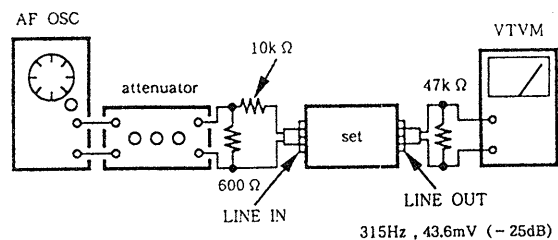

2. Mode : playback

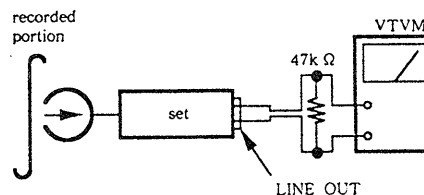

3. Playback the signal recorded in step1.

Confirm that the signal level is within the adjustment limits below. If necessary, adjust RV102 (L-ch) and RV302 (R-ch) repeat the step1-2.

Adjustment Limits : $-25\text{dB} \pm 0.5\text{dB}$ (42-46mV)

Adjustment Location : Main board

Quick Reverse Sensitivity Adjustment

Conditions :

DIRECTION MODE switch : \rightleftarrows

Adjustment procedure :

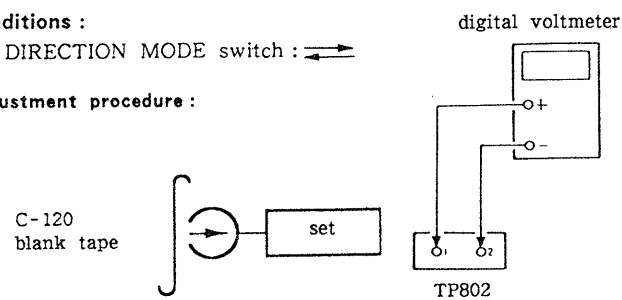

1. Connect the digital voltmeter to test point TP802.
2. Load C-120 tape cassette and play back the leading portion in FWD mode.
3. Adjust the RV801 for $4.5 \pm 0.5\text{V}$ reading on the digital voltmeter.
4. Play back C-120 tape cassette in FWD mode again.
5. Confirm that the reading on the digital voltmeter is "L" level at the magnetic portion of the tape.
6. Confirm that the tape stop around the tape end (border of the leading and the magnetic portions).

Adjustment Location : Main board

Adjustment Parts Location

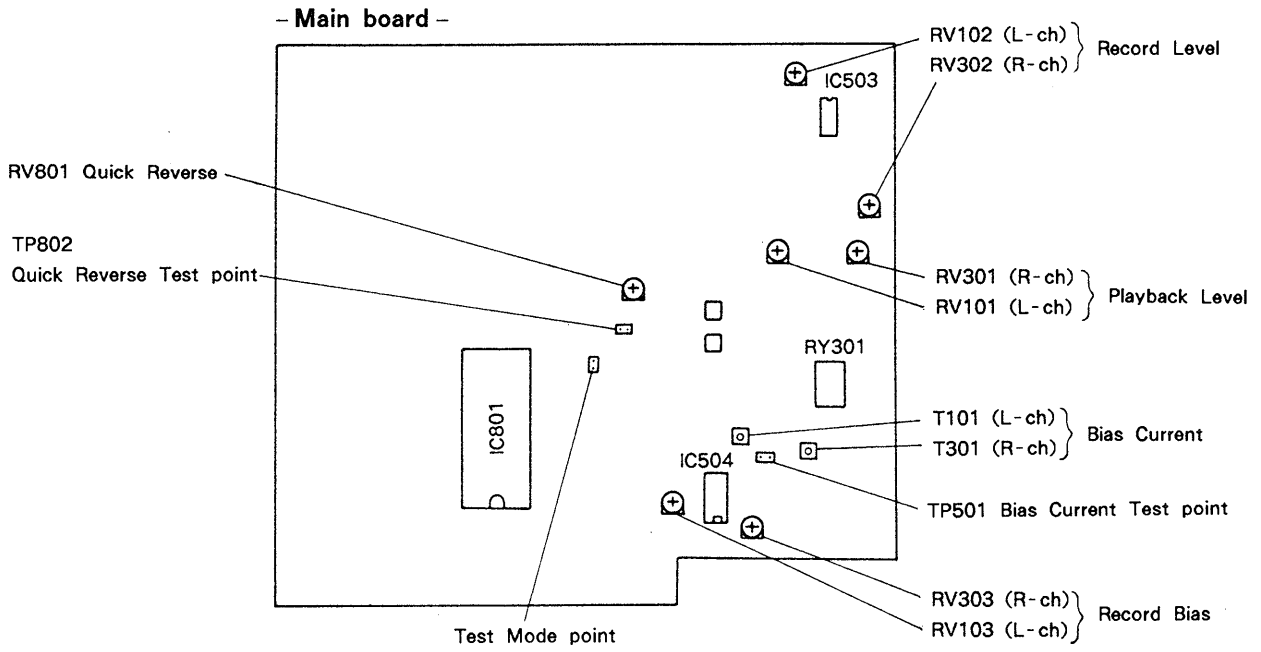

SECTION 4 DIAGRAMS

4-1. SEMICONDUCTOR LEAD LAYOUTS

MB88517B-1023N

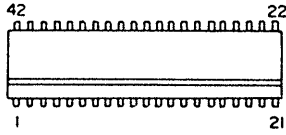

(TOP VIEW)

2SB1013-4

2SB1116A-L

2SC945-P

2SD1387

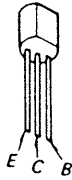

DTA114ES

DTA144ES

DTC114ES

DTC143TS

2SA1317-STU

2SC2603-EF

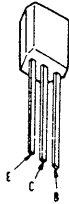

2SD1020-HFE

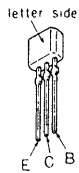

2SB1187-EF

2SD1761-EF

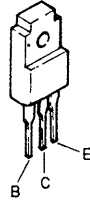

1SS202-1

HZS6A1L

HZS6C1L

HZS9A2L

RD4.3ES-B1

UZL-7H1

UZL-9H2L

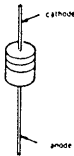

10E2N

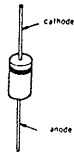

SEL2210S-C

SEL2410E-D

SEL2910A

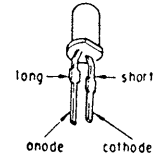

SEL1210S

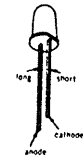

SEL4214W

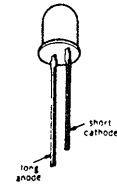

GP2S22B

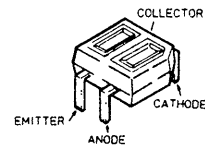

4-2. CIRCUIT BOARDS LOCATION

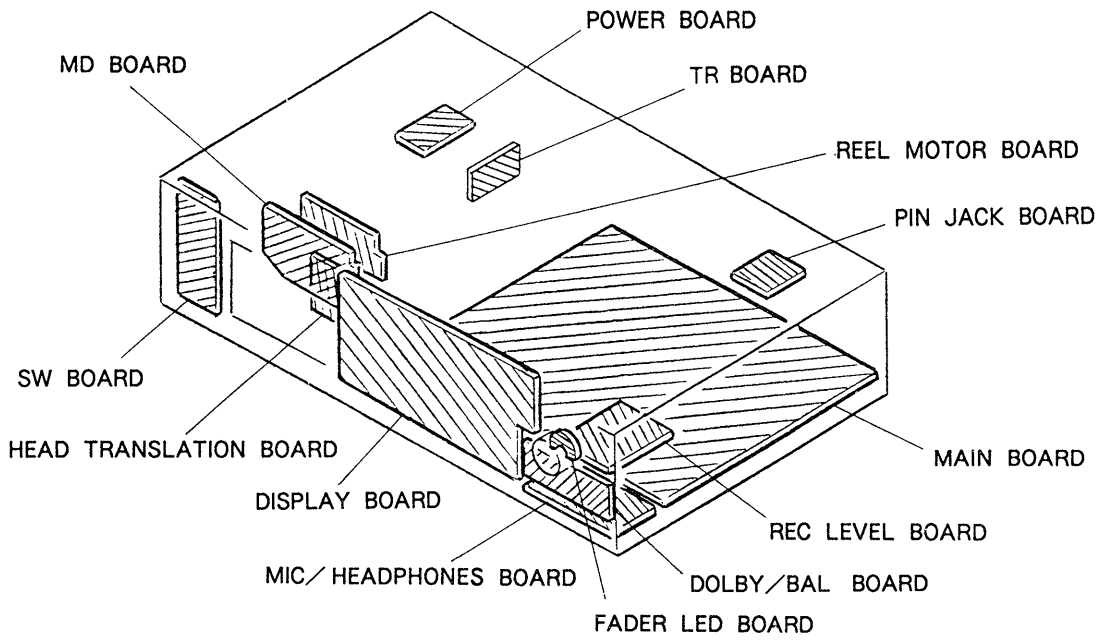

Ref. No.	Location	Ref. No.	Location
D101	F-20	IC801	G-22
D301	F-19	IC802	H-24
D501	D-17	IC803	F-25
D502	D-17	IC804	H-25
D503	E-19	IC805	C-22
D504	H-17	IC806	D-22
D505	D-19	IC901	I-10
D506	B-16	IC902	I-13
D507	B-17	IC1001	H-2
D508	B-17	IC1002	H-4
D701	C-24		
D702	C-25	Q101	E-18
D703	C-24	Q102	C-20
D704	C-25	Q103	B-18
D705	C-24	Q104	C-17
D706	C-25	Q301	E-17
D707	D-24	Q302	C-19
D708	C-23	Q303	A-18
D709	A-24	Q304	B-18
D710	A-25	Q501	I-17
D711	D-26	Q502	A-17
D712	D-25	Q503	B-17
D713	D-26	Q504	B-17
D714	D-24	Q505	H-20
D715	A-23	Q506	H-20
D716	C-26	Q507	H-20
D717	B-24	Q508	H-20
D718	A-23	Q510	I-17
D719	E-24	Q511	H-17
D720	B-23	Q701	C-23
D721	B-22	Q702	B-23
D801	G-18	Q703	A-24
D802	C-19	Q704	B-25
D803	D-21	Q705	B-27
D804	D-20	Q706	C-26
D805	I-25	Q707	C-26
D806	J-25	Q708	C-26
D807	J-25	Q709	C-24
D808	F-25	Q710	B-18
D809	F-24	Q801	H-22
D810	F-24	Q802	G-21
D811	F-25	Q803	G-21
D812	G-24	Q804	G-21
D813	G-24	Q805	G-21
D814	F-24	Q806	G-21
D815	F-24	Q807	F-21
D816	C-23	Q808	E-21
D817	C-22	Q809	F-21
D818	H-21	Q810	E-23
D820	F-20	Q811	F-23
D821	G-25	Q812	G-24
D901	I-12	Q813	G-24
D902	I-12	Q814	F-24
D903	I-9	Q815	G-24
D904	I-10	Q816	E-23
D905	I-7	Q817	F-24
D906	F-23	Q818	F-24
D907	I-7	Q819	F-24
D908	H-10	Q820	D-20
D909	H-11	Q821	D-21
D910	H-13	Q822	D-19
D911	H-10	Q823	G-18
D912	H-9	Q824	D-23
D913	H-12	Q825	D-22
D914	D-10	Q826	D-22
D1091	C-3	Q827	D-22
D1051	F-4	Q828	D-22
		Q829	I-22
IC501	E-17	Q830	F-20
IC502	B-20	Q831	G-20
IC503	B-17	Q901	I-8
IC504	H-19	Q902	I-8
IC505	E-19	Q903	J-13
IC506	F-19	Q904	J-13
IC651	C-13	Q905	J-13
IC652	C-11	Q906	J-13
IC701	B-24	Q1091	C-3

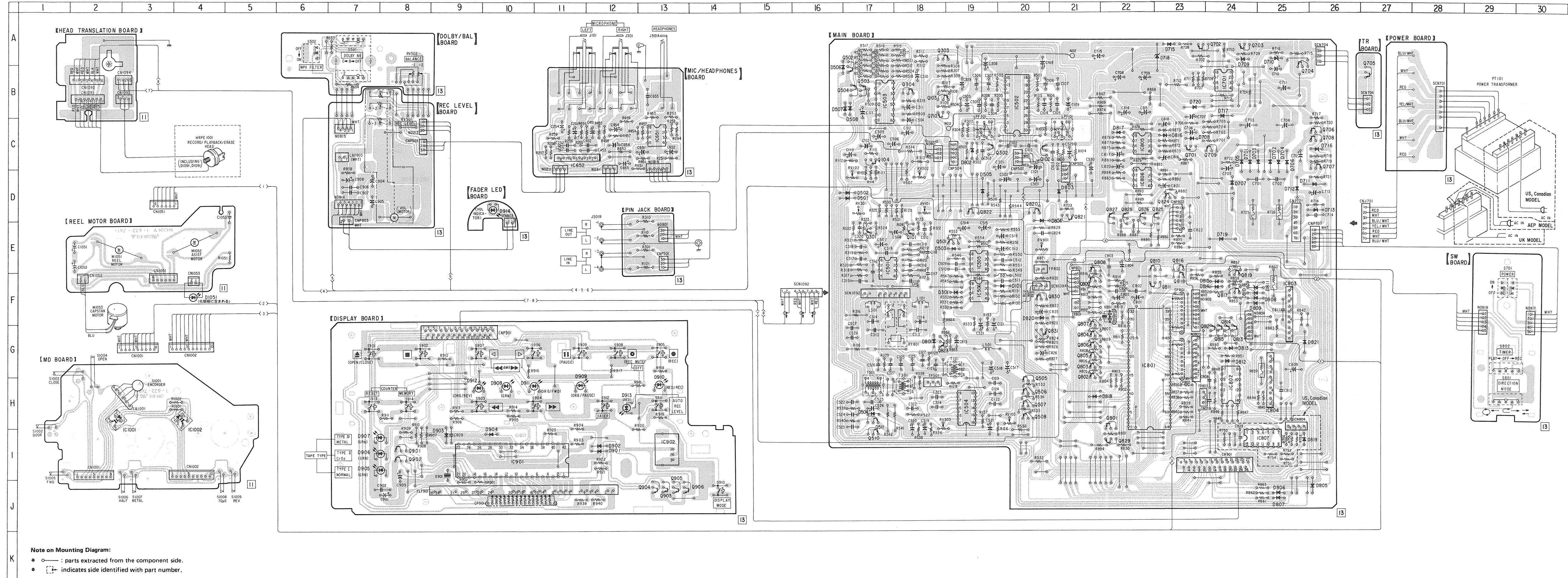

Note on Mounting Diagram:
 • ○ — parts extracted from the component side.
 • □ — indicates side identified with part number.

4-4. SCHEMATIC DIAGRAM

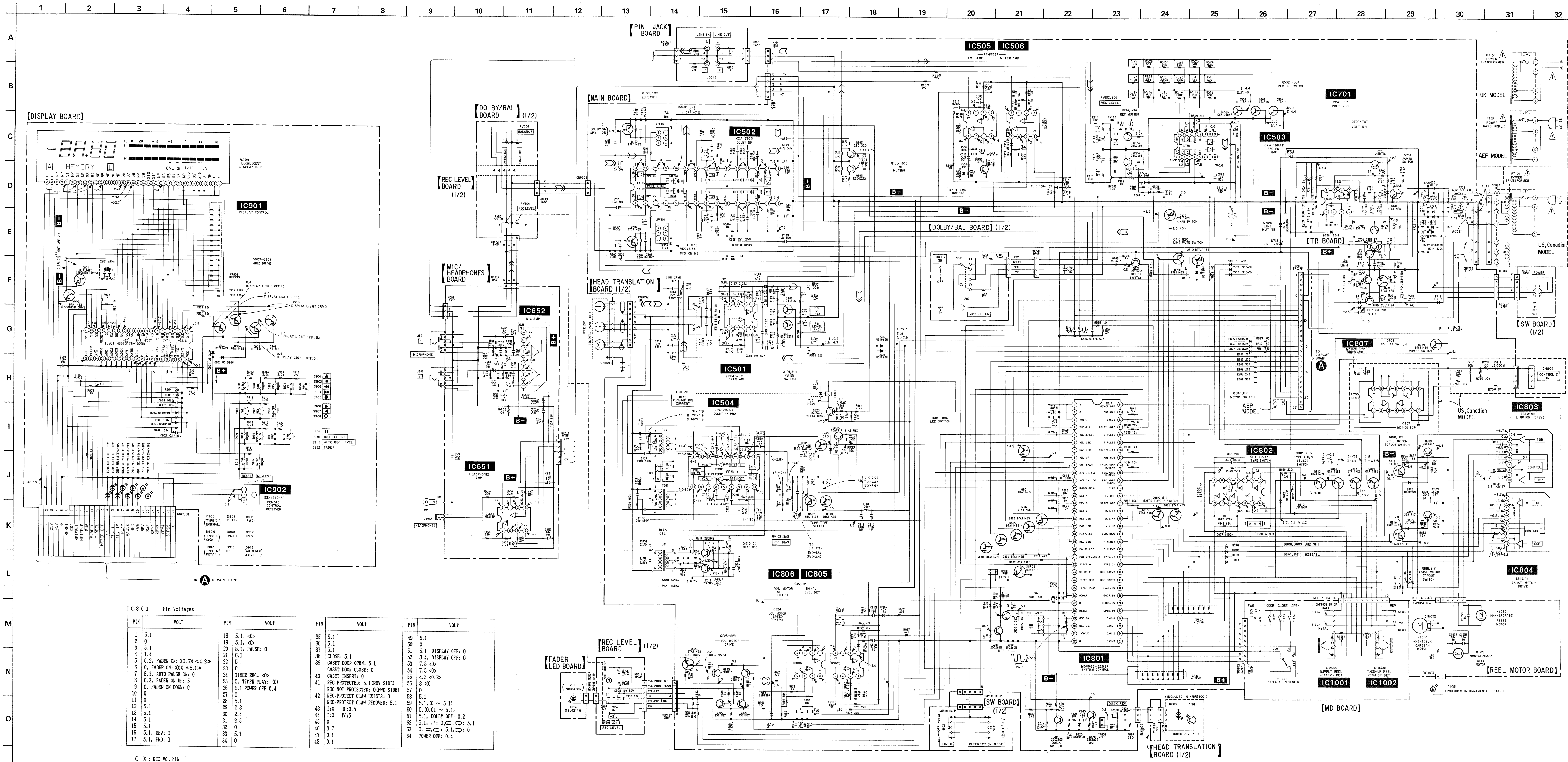

Note on Schematic Diagram:

- All capacitors are in μF unless otherwise noted. pF: μF 50WV or less are not indicated except for electrolytics and tantalums.
- All resistors are in Ω and $\frac{1}{2}W$ or less unless otherwise specified.
- Δ : internal component.
- \square : fusible resistor.

Note: The components identified by mark Δ or dotted line with mark Δ are critical for safety. Replace only with part number specified.

Note: Les composants identifiés par une marque Δ ou une ligne pointillée avec une marque Δ sont critiques pour la sécurité. Ne les remplacer que par une pièce portant le numéro spécifié.

IC801 Pin Voltages

PIN	VOLT	PIN	VOLT	PIN	VOLT	PIN	VOLT
1	5.1	18	5.1, <<>	35	5.1	49	5.1
2	0	19	5.1, <<>	36	5.1	50	0
3	5.1	20	5.1, PAUSE: 0	37	5.1	51	5.1, DISPLAY OFF: 0
4	1.4	21	6.1	38	CLOSE: 5.1	52	3.4, DISPLAY OFF: 0
5	0.2, FADER ON: (0.0) <4.2>	22	5	39	CASSET DOOR OPEN: 5.1	53	7.5 <<>
6	0, FADER ON: (0.0) <5.1>	23	0	40	CASSET DOOR CLOSE: 0	54	7.5 <<>
7	5.1, AUTO PAUSE ON: 0	24	TIMER REC: <<>	41	CASSET INSERT: 0	55	4.3 <<>
8	0.3, FADER ON UP: S	25	0, TIMER PLAY: (0)	42	REC PROTECTED: 5.1 (REV SIDE)	56	3 (0)
9	0, FADER ON DOWN: 0	26	REC NOT PROTECTED: 0 (FWD SIDE)	43	REC-PROTECT CLAW EXISTS: 0	57	0
10	0	27	0	44	REC-PROTECT CLAW REMOVED: 5.1	58	5.1
11	0	28	5.1	45	11.0 B:0.5	59	5.1, (0 ~ 5.1)
12	5.1	29	2.3	46	1:0 IV:5	60	0, (0.01 ~ 5.1)
13	5.1	30	2.4	47	0	61	5.1, DOLBY OFF: 0.2
14	5.1	31	2.5	48	0	62	5.1, 0, 0, C: 5.1
15	5.1, REV: 0	32	0			63	0, C: 5.1, C: 0
16	5.1, REV: 0	33	5.1			64	POWER OFF: 0.4
17	5.1, FWD: 0	34	0				

(<>): REC VOL MIN
< >: REC VOL MAX

SECTION 5 EXPLODED VIEWS

NOTE:

- The mechanical parts with no reference number in the exploded views are not supplied.
- The construction parts of an assembled part are indicated with a collation number in the remark column.
- Items marked "★" are not stocked since they are seldom required for routine service. Some delay should be anticipated when ordering these items.

- Due to standardization, parts with part number suffix -XX and -X may be different from the parts specified in the components used on the set.
- Color Indication of Appearance Parts
Example:
(RED) ... KNOB, BALANCE (WHITE)
↑ Cabinet's Color ↑ Parts' Color

The components identified by mark or dotted line with mark are critical for safety. Replace only with part number specified.

Les composants identifiés par une marque sont critiques pour la sécurité. Ne les remplacer que par une pièce portant le numéro spécifié.

5-1. FRONT PANEL SECTION

- A: REC LEVEL BOARD
- B: DOLBY/BAL BOARD
- C: MIC/HEADPHONES BOARD
- D: SW BOARD
- E: FADER LED BOARD

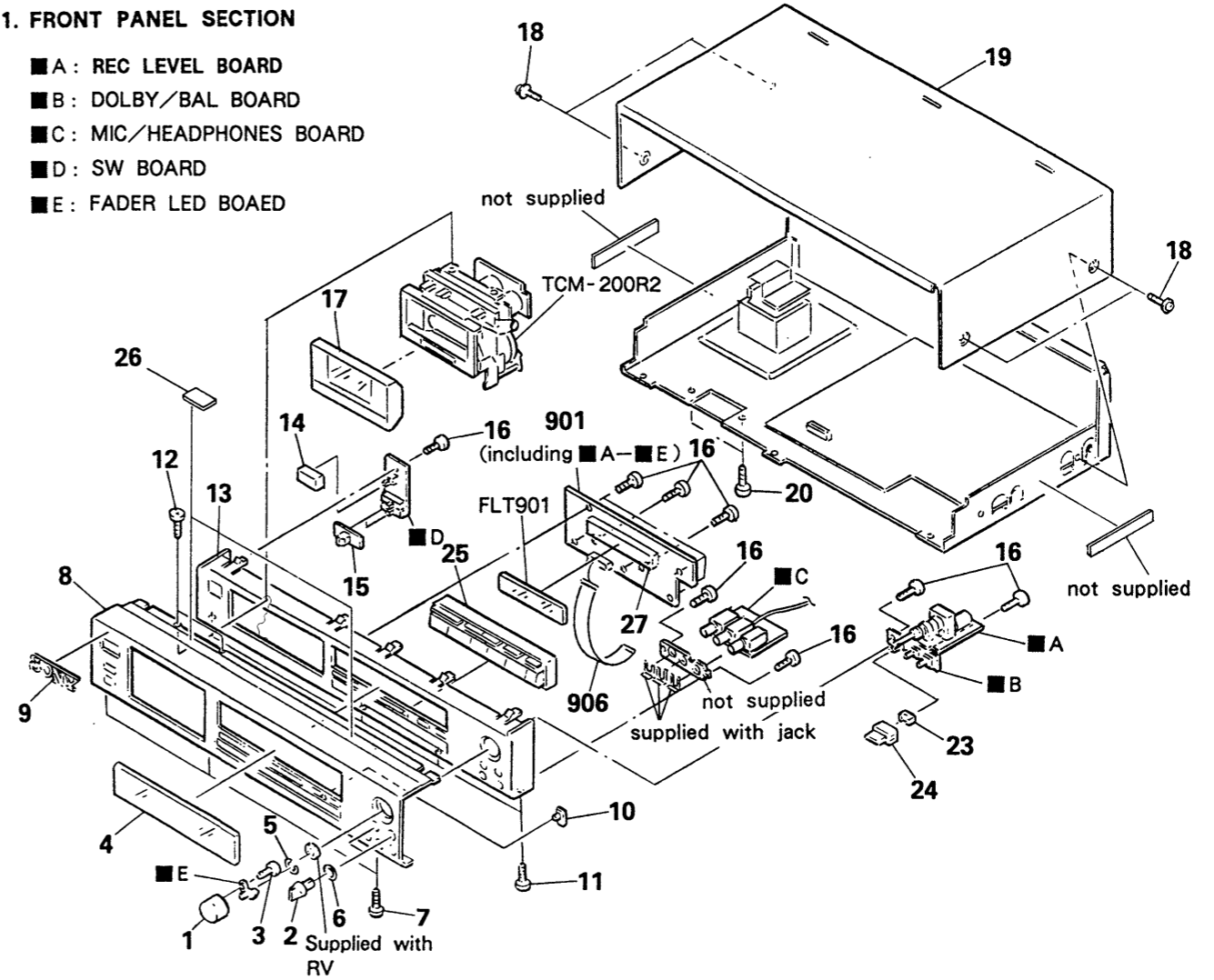

No.	Part No.	Description	Remarks	No.	Part No.	Description	Remarks
1	X-3304-954-1	KNOB (R) ASSY		14	4-922-921-01	BUTTON (POWER)	
2	3-350-495-01	KNOB (VOL)		15	4-931-421-11	KNOB (T & S)	
3	7-685-133-19	SCREW +BTP 2.6X6 TYPE2 N-S		16	4-928-635-01	SCREW, +BV (2.6X8) TAPPING	
4	3-350-838-11	WINDOW (M)		17	X-3332-562-1	LID ASSY, CASSETTE	
5	3-350-440-01	SPRING		18	3-704-366-01	SCREW (CASE) (M3X8)	
6	3-356-957-01	SPRING		19	3-332-578-61	CASE	
7	7-682-548-09	SCREW, +BVTT 3X8 (S)		20	7-682-547-09	SCREW +BVTT 3X6 (S)	
8	3-350-841-11	(US,Canadian)...PANEL, FRONT		23	4-864-307-00	RING	
	3-350-841-21	(AEP).....PANEL, FRONT		24	3-304-926-11	KNOB (A), PUSH	
	3-350-841-31	(UK).....PANEL, FRONT		25	3-350-839-01	BUTTON	
9	4-908-848-01	EMBLEM, SONY		27	*3-350-824-01	HOLDER (FL)	
10	3-684-018-01	COVER, LAMP, REC		901	*A-2006-236-A	(AEP).....MOUNTED PCB, PANEL	
11	7-685-534-19	SCREW +BTP 2.6X8 TYPE2 N-S			*A-2006-265-A	(US,Canadian,UK)...MOUNTED PCB, PANEL	
12	7-682-547-04	SCREW +BV 3X6, S TIGHT				(including ■ A-E)	
13	3-350-842-01	PANEL (BASE)		906	1-575-628-11	WIRE, FLAT TYPE (27 CORE)	
				FLT901	1-519-493-11	INDICATOR TUBE, FLUORESCENT	

5-2. CHASSIS SECTION

▲ A : PIN JACK BOARD

▲ B : POWER BOARD

▲ C : TR BOARD

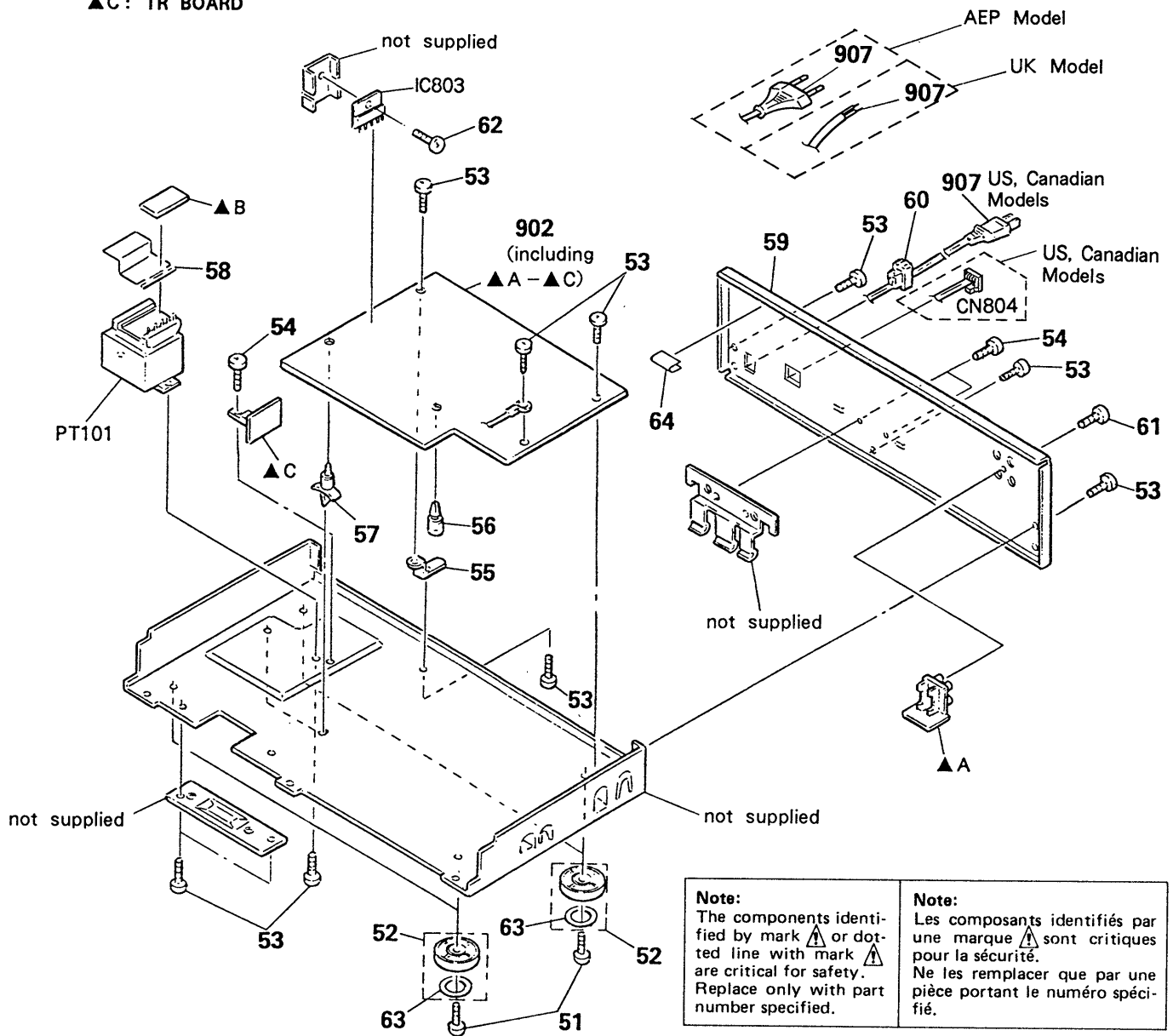

<p>Note: The components identified by mark ▲ or dotted line with mark ▲ are critical for safety. Replace only with part number specified.</p>	<p>Note: Les composants identifiés par une marque ▲ sont critiques pour la sécurité. Ne les remplacer que par une pièce portant le numéro spécifié.</p>
--	--

No.	Part No.	Description	Remarks	No.	Part No.	Description	Remarks
51	7-682-548-04	SCREW +BVTT 3X8 (S)		902	*A-2006-234-A	(AEP,UK).....MOUNTED PCB, MAIN	
52	X-3304-938-2	FOOT ASSY			*A-2006-235-A	(US,Canadian)...MOUNTED PCB, MAIN	(including ▲ A-C)
53	7-682-548-09	SCREW +BVTT 3X8 (S)		907	▲.1-551-506-XX	(US,Canadian)...CORD, POWER	
54	7-682-547-09	SCREW +BVTT 3X6 (S)			▲.1-555-795-00	(AEP).....CORD, POWER	
55	*3-332-563-01	BRACKET (P)			▲.1-556-035-00	(UK).....CORD, POWER	
56	*3-669-610-00	SPACER		CN804	1-558-350-31	(US,Canadian)...CORD (WITH CONNECTOR)	(SIRCS)
57	*3-346-265-11	HOLDER, PC BOARD		IC803	8-759-973-65	IC BA6219B	
58	*3-337-136-11	COVER, TRANSFORMER SAFETY		PT101▲.1-450-018-11	(US,Canadian)...TRANSFORMER, POWER		
59	*3-350-843-11	(US,Canadian)...PANEL, BACK		PT101▲.1-450-019-11	(AEP,UK).....TRANSFORMER, POWER		
	*3-350-843-41	(AEP).....PANEL, BACK					
	*3-350-843-51	(UK).....PANEL, BACK					
60	*3-703-244-00	(AEP,UK).....BUSHING (2104), CORD					
	*3-703-571-11	(US,Canadian)...BUSHING (S) (4516), CORD					
61	7-621-849-00	SCREW, TAPPING					
62	7-682-547-04	SCREW +BVTT 3X6 (S)					
63	4-923-836-11	CUSHION					
64	3-831-441-XX	CUSHION (B), CABINET					

5-3. MECHANISM SECTION (TCM-200R2)

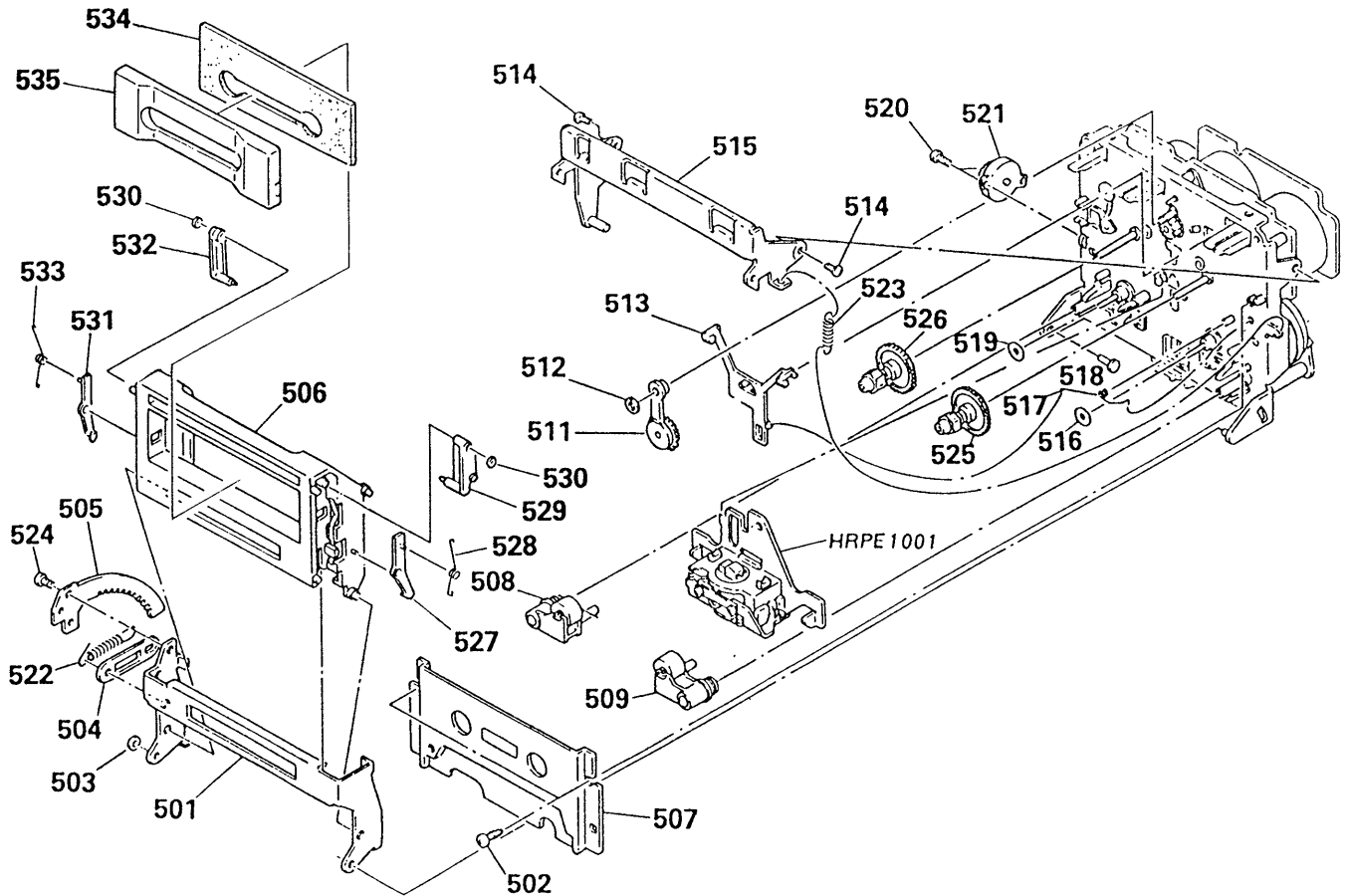

No.	Part No.	Description	Remarks	No.	Part No.	Description	Remarks
501	X-3356-612-1	HOLDER (B) ASSY, CASSETTE		520	7-685-851-09	SCREW +BVTT 2X4 (S)	
502	7-685-133-19	SCREW +BTP 2.6X6 TYPE2 N-S		521	3-712-786-41	DAMPER, OIL	
503	3-558-708-21	WASHER, STOPPER		522	3-356-626-01	SPRING, TENSION	
504	*3-356-717-01	LEVER (JOINT)		523	3-356-625-01	SPRING, TENSION	
505	3-356-708-01	GEAR (SOFT EJECT)		524	7-621-775-10	SCREW +B 2.6X4	
506	X-3356-611-1	HOLDER (A) ASSY, CASSETTE		525	X-3356-627-1	GEAR (T) ASSY	
507	X-3356-613-1	PLATE ASSY, ORNAMENTAL		526	X-3356-628-1	GEAR (S) ASSY	
508	X-3343-455-1	LEVER (PINCH F) ASSY		527	3-356-930-01	LEVER (RA)	
509	X-3343-456-1	LEVER (PINCH R) ASSY		528	3-356-926-01	SPRING (RIGHT), TORSION	
511	X-3356-641-1	LEVER (FR2) ASSY		529	3-356-931-01	LEVER (RB)	
512	3-701-436-11	WASHER, 1.6 POLYETHYLENE		530	3-356-946-01	BUSHING	
513	3-356-614-01	SLIDER (BRAKE)		531	3-356-932-01	LEVER (LA)	
514	3-356-601-11	SCREW, STEP		532	3-356-933-01	LEVER (LB)	
515	*X-3356-608-1	LEVER (LIFTER) ASSY		533	3-356-927-01	SPRING (LEFT), TORSION	
516	3-356-713-01	WASHER		534	3-356-731-01	ABSORBENT, VIBRATION	
517	3-356-619-01	SPRING (B), TORSION		535	3-356-928-01	PLATE (A), ORNAMENTAL	
518	3-356-710-01	SHAFT (LEFT) (CASSETTE HOLDER)		HRPE1001	A-2003-533-A	SLIDER COMPLETE ASSY	
519	3-356-714-01	WASHER					

5-4. MECHANISM SECTION (TCM-200R2)

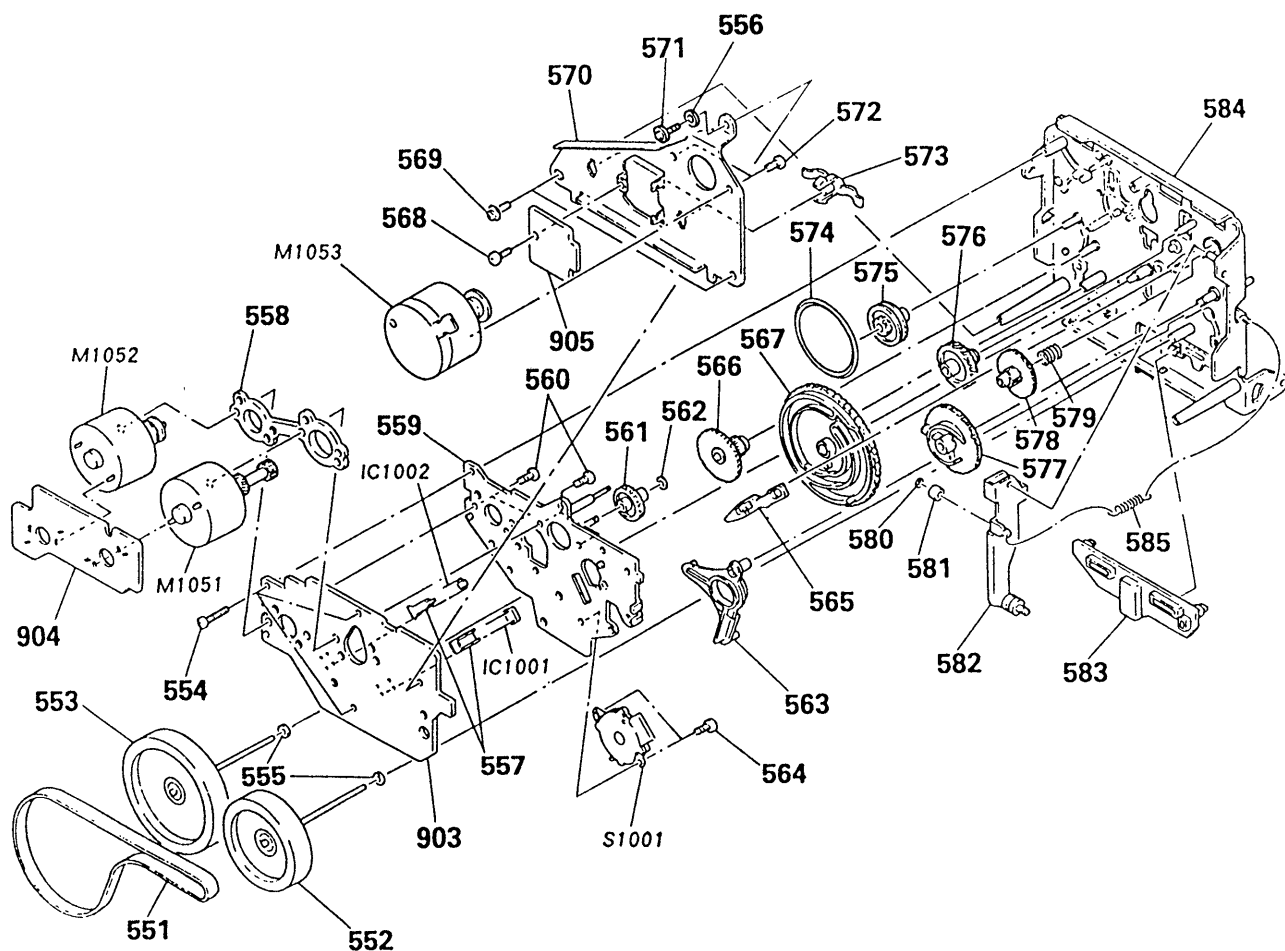

No.	Part No.	Description	Remarks	No.	Part No.	Description	Remarks
551	3-356-730-01	BELT (CAPSTAN R2)		573	3-575-321-00	RETAINER, THRUST, CAPSTAN	
552	X-3356-642-1	FLYWHEEL (R FWD) ASSY		574	3-356-603-01	BELT (MODE)	
553	X-3356-643-1	FLYWHEEL (R REV) ASSY		575	3-356-607-01	PULLEY (MODE)	
554	3-355-801-01	SCREW (BTP 2X18)		576	3-356-703-01	GEAR (COMMUNICATION C)	
555	3-356-705-01	WASHER (CAPSTAN)		577	3-356-616-01	GEAR (LOADING CAM)	
556	*3-356-718-01	SPACER (THRUST RETAINER R)		578	3-356-609-01	GEAR (LOADING)	
557	3-356-631-01	HOLDER (SENSOR)		579	3-356-605-01	SPRING, COMPRESSION	
558	*3-356-628-01	SPACER (MOTOR)		580	3-558-708-11	WASHER, STOPPER	
559	*X-3356-602-1	BRACKET (MOTOR R) ASSY		581	3-356-630-01	ROLLER (LOADING)	
560	7-621-773-95	SCREW +B 2.6X6		582	*X-3356-606-1	LEVER (LOADING) ASSY	
561	3-356-702-01	GEAR (COMMUNICATION B)		583	3-356-612-01	SLIDER (REVERSE)	
562	3-669-465-00	WASHER (1.5), STOPPER		584	X-3356-634-1	CHASSIS (R2) COMPLETE ASSY, MECH	
563	3-356-613-01	LEVER (MODE)		585	3-356-624-01	SPRING, TENSION	
564	7-621-772-20	SCREW +B 2X5		903	*1-632-740-11	PC BOARD, MD	
565	3-356-617-01	LEVER (SELECTION)		904	*1-632-741-11	PC BOARD, REEL MOTOR	
566	3-356-606-01	GEAR (MODE)		905	*1-634-323-11	PC BOARD, HEAD TRANSLATION	
567	3-356-615-01	GEAR (MODE CAM RR)		IC1001	8-749-920-97	PHOTO REFLECTOR GP2S22B	
568	7-621-770-67	SCREW +BVT 2.6X6 (S)		IC1002	8-749-920-97	PHOTO REFLECTOR GP2S22B	
569	4-928-635-01	SCREW, +BV (2.6X8) TAPPING		M1051	X-3356-638-1	MOTOR (REEL R) ASSY	
570	*3-356-629-01	BRACKET (THRUST RETAINER R)		M1052	X-3356-604-1	MOTOR (ASSIST) ASSY	
571	3-356-707-01	SCREW (+PTWH 2X25)		M1053	X-3356-635-1	MOTOR (CAPSTAN R2) ASSY	
572	7-621-775-00	SCREW +B 2.6X3		S1001	1-466-237-11	ENCODER, ROTARY	

SECTION 5 ELECTRICAL PARTS LIST

NOTE:

- Due to standardization, replacements in the parts list may be different from the parts specified in the diagrams or the components used on the set.
- Items marked "★" are not stocked since they are seldom required for routine service. Some delay should be anticipated when ordering these items.
- If there are two or more same circuits in a set such as a stereophonic machine, only typical circuit parts may be indicated and capacitors and resistors in other same circuits may be omitted.

CAPACITORS:

MF: μ F, PF: μ MF.

RESISTORS

- All resistors are in ohms.
- F: nonflammable

COILS

- MMH: mH, UH: μ H

SEMICONDUCTORS

In each case, U: μ , for example:
 UA...: μ A..., UPA...: μ PA...,
 UPC...: μ PC, UPD...: μ PD...

The components identified by mark Δ or dotted line with mark Δ are critical for safety. Replace only with part number specified.

Les composants identifiés par une marque Δ sont critiques pour la sécurité. Ne les remplacer que par une pièce portant le numéro spécifié.

Ref.No.	Part No.	Description	Ref.No.	Part No.	Description				
901	*A-2006-236-A	(AEP).....MOUNTED PCB, PANEL	C254	1-124-438-00	ELECT	1MF	20%	50V	
	*A-2006-265-A	(US,Canadian,UK)...MOUNTED PCB, PANEL (including \blacksquare A-E)	C301	1-123-875-11	ELECT	10MF	20%	50V	
			C302	1-162-294-31	CERAMIC	0.001MF	10%	50V	
902	*A-2006-234-A	(AEP,UK).....MOUNTED PCB, MAIN	C303	1-161-375-00	CERAMIC	0.0022MF	20%	16V	
	*A-2006-235-A	(US,Canadian)...MOUNTED PCB, MAIN (including \blacktriangle A-C)	C304	1-130-475-00	MYLAR	0.0022MF	5%	50V	
			C305	1-130-475-00	MYLAR	0.0022MF	5%	50V	
903	*1-632-740-11	PC BOARD, MD	C306	1-136-174-00	FILM	0.56MF	5%	50V	
904	*1-632-741-11	PC BOARD, REAL MOTOR	C307	1-136-171-00	FILM	0.33MF	5%	50V	
905	*1-634-323-11	PC BOARD, TRANSLATION	C308	1-123-875-11	ELECT	10MF	20%	50V	
906	1-575-628-11	WIRE, FLAT TYPE (27 CORE)	C309	1-124-927-11	ELECT	4.7MF	20%	50V	
907	Δ .1-551-506-XX	(US,Canadian)...CORD, POWER	C310	1-124-902-00	ELECT	0.47MF	20%	50V	
	Δ .1-555-795-00	(AEP).....CORD, POWER	C311	1-123-875-11	ELECT	10MF	20%	50V	
	Δ .1-556-035-00	(UK).....CORD, POWER	C312	1-123-875-11	ELECT	10MF	20%	50V	
C101	1-123-875-11	ELECT	10MF	20%	50V				
C102	1-162-294-31	CERAMIC	0.001MF	10%	50V				
C103	1-161-375-00	CERAMIC	0.0022MF	20%	16V				
C104	1-130-475-00	MYLAR	0.0022MF	5%	50V				
C105	1-130-475-00	MYLAR	0.0022MF	5%	50V				
C106	1-136-174-00	FILM	0.56MF	5%	50V				
C107	1-136-171-00	FILM	0.33MF	5%	50V				
C108	1-123-875-11	ELECT	10MF	20%	50V				
C109	1-124-927-11	ELECT	4.7MF	20%	50V				
C110	1-124-902-00	ELECT	0.47MF	20%	50V				
C111	1-123-875-11	ELECT	10MF	20%	50V				
C112	1-123-875-11	ELECT	10MF	20%	50V				
C113	1-162-285-31	CERAMIC	180PF	10%	50V				
C114	1-136-935-11	FILM	22PF	5%	630V				
C115	1-162-294-31	CERAMIC	0.001MF	10%	50V				
C116	1-162-282-31	CERAMIC	100PF	10%	50V				
C117	1-136-157-00	FILM	0.022MF	5%	50V				
C118	1-124-657-00	ELECT	10MF	20%	50V				
C119	1-161-494-00	CERAMIC	0.022MF		25V				
C120	1-136-158-00	FILM	0.027MF	5%	50V				
C121	1-123-382-00	ELECT	3.3MF	20%	50V				
C122	1-136-153-00	FILM	0.01MF	5%	50V				
C123	1-136-157-00	FILM	0.022MF	5%	50V				
C124	1-136-161-00	FILM	0.047MF	5%	50V				
C125	1-136-272-00	FILM	68PF	5%	630V				
C126	1-130-468-00	MYLAR	560PF	5%	50V				
C127	1-136-433-11	FILM	100PF	5%	630V				
C251	1-124-791-11	ELECT	1MF	20%	50V				
C252	1-162-292-31	CERAMIC	680PF	10%	50V				
C253	1-162-282-31	CERAMIC	100PF	10%	50V				
			C451	1-124-791-11	ELECT	1MF	20%	50V	
			C452	1-162-292-31	CERAMIC	680PF	10%	50V	
			C453	1-162-282-31	CERAMIC	100PF	10%	50V	
			C454	1-124-438-00	ELECT	1MF	20%	50V	
			C501	1-123-875-11	ELECT	10MF	20%	50V	
			C502	1-123-875-11	ELECT	10MF	20%	50V	
			C503	1-126-233-11	ELECT	22MF	20%	25V	
			C504	1-124-791-11	ELECT	1MF	20%	50V	
			C505	1-123-875-11	ELECT	10MF	20%	50V	
			C506	1-123-875-11	ELECT	10MF	20%	50V	
			C507	1-124-443-00	ELECT	100MF	20%	10V	
			C508	1-124-443-00	ELECT	100MF	20%	10V	
			C509	1-162-217-31	CERAMIC	56PF	5%	50V	
			C510	1-161-494-00	CERAMIC	0.022MF		25V	
			C512	1-162-217-31	CERAMIC	56PF	5%	50V	
			C513	1-124-925-11	ELECT	2.2MF	20%	50V	
			C514	1-124-443-00	ELECT	100MF	20%	10V	

Ref.No.	Part No.	Description				Ref.No.	Part No.	Description			
C515	1-124-443-00	ELECT	100MF	20%	10V	C824	1-161-377-00	CERAMIC	0.0047MF	30%	16V
C516	1-124-902-00	ELECT	0.47MF	20%	50V	C825	1-124-477-11	ELECT	47MF	20%	16V
C517	1-126-101-11	ELECT	100MF	20%	16V	C826	1-124-927-11	ELECT	4.7MF	20%	50V
C518	1-126-101-11	ELECT	100MF	20%	16V	C901	1-124-443-00	ELECT	100MF	20%	10V
C519	1-124-902-00	ELECT	0.47MF	20%	50V	C902	1-161-494-00	CERAMIC	0.022MF		25V
C520	1-124-477-11	ELECT	47MF	20%	16V	C903	1-126-157-11	ELECT	10MF	20%	16V
C521	1-124-477-11	ELECT	47MF	20%	16V	C904	1-124-446-11	ELECT	47MF	20%	10V
C522	1-136-230-00	FILM	0.0022MF	5%	100V	C905	1-124-446-11	ELECT	47MF	20%	10V
C523	1-136-230-00	FILM	0.0022MF	5%	100V	C906	1-164-159-11	CERAMIC	0.1MF		50V
C524	1-130-856-00	FILM	0.0068MF	5%	100V	C907	1-164-159-11	CERAMIC	0.1MF		50V
C525	1-161-494-00	CERAMIC	0.022MF		25V	C908	1-123-875-11	ELECT	10MF	20%	50V
C526	1-123-875-11	ELECT	10MF	20%	50V	C909	1-162-294-31	CERAMIC	0.001MF	10%	50V
C527	1-136-558-11	FILM	0.0039MF	5%	630V	C1051	1-123-875-11	ELECT	10MF	20%	50V
C528	1-107-046-00	MICA	4.7PF	0.5PF	500V	C1052	1-123-875-11	ELECT	10MF	20%	50V
C529	1-124-791-11	ELECT	1MF	20%	50V	C1053	1-164-159-11	CERAMIC	0.1MF		50V
C530	1-124-902-00	ELECT	0.47MF	20%	50V	CN804	1-558-350-31	(US,Canadian)...CORD (WITH CONNECTOR)			(SIRCS)
C651	1-123-875-11	ELECT	10MF	20%	50V	CN1001	1-506-615-11	PIN, CONNECTOR 9P			
C652	1-123-875-11	ELECT	10MF	20%	50V	CN1002*1	1-564-502-11	PIN, CONNECTOR 10P			
C653	1-124-443-00	ELECT	100MF	20%	10V	CN1051*1	1-564-499-11	PIN, CONNECTOR 6P			
C654	1-124-443-00	ELECT	100MF	20%	10V	CN1052*1	1-564-718-11	PIN, CONNECTOR (SMALL TYPE) 2P			
C655	1-162-294-31	CERAMIC	0.001MF	10%	50V	CN1053*1	1-564-718-11	PIN, CONNECTOR (SMALL TYPE) 2P			
C701	1-164-159-11	CERAMIC	0.1MF		50V	CN1091*1	1-564-709-11	PIN, CONNECTOR (SMALL TYPE) 7P			
C702	1-164-159-11	CERAMIC	0.1MF		50V	CN1092*1	1-564-509-11	PLUG, CONNECTOR 6P			
C703	1-124-898-11	ELECT	4700MF	20%	16V	CN1093*1	1-564-705-11	PIN, CONNECTOR (SMALL TYPE) 3P			
C704	1-124-898-11	ELECT	4700MF	20%	16V	CN1094*1	1-564-506-11	PLUG, CONNECTOR 3P			
C705	1-123-875-11	ELECT	10MF	20%	50V	CNP501*1	1-564-337-00	PIN, CONNECTOR 3P			
C706	1-124-477-11	ELECT	47MF	20%	16V	CNP502*1	1-564-705-11	PIN, CONNECTOR (SMALL TYPE) 3P			
C707	1-124-477-11	ELECT	47MF	20%	16V	CNP503*1	1-564-705-11	PIN, CONNECTOR (SMALL TYPE) 3P			
C708	1-124-473-11	ELECT	1000MF	20%	10V	CNP504*1	1-564-339-00	PIN, CONNECTOR 5P			
C709	1-124-473-11	ELECT	1000MF	20%	10V	CNP505*1	1-564-338-00	PIN, CONNECTOR 4P			
C710	1-124-477-11	ELECT	47MF	20%	16V	CNP701*1	1-564-510-11	PLUG, CONNECTOR 7P			
C711	1-124-893-11	ELECT	2200MF	20%	6.3V	CNP707*1	1-564-339-61	PIN, CONNECTOR 5P			
C712	1-124-122-11	ELECT	100MF	20%	50V	CNP801*1	1-564-339-71	PIN, CONNECTOR 5P			
C713	1-123-875-11	ELECT	10MF	20%	50V	CNP802*1	1-564-340-00	PIN, CONNECTOR 6P			
C714	1-164-159-11	CERAMIC	0.1MF		50V	CNP803*1	1-564-505-11	PLUG, CONNECTOR 2P			
C715	1-124-473-11	ELECT	1000MF	20%	10V	CNP901*1	1-568-842-11	SOCKET, CONNECTOR 27P			
C801	1-124-443-00	ELECT	100MF	20%	10V	CP801	1-233-204-11	COMPOSITION CIRCUIT BLOCK			
C802	1-161-494-00	CERAMIC	0.022MF		25V	CP802	1-233-204-11	COMPOSITION CIRCUIT BLOCK			
C803	1-161-494-00	CERAMIC	0.022MF		25V	CP901	1-233-205-11	COMPOSITION CIRCUIT BLOCK			
C804	1-124-927-11	ELECT	4.7MF	20%	50V	D101	8-719-107-94	DIODE 1SS202-1			
C805	1-123-875-11	ELECT	10MF	20%	50V	D301	8-719-107-94	DIODE 1SS202-1			
C806	1-161-494-00	CERAMIC	0.022MF		25V	D501	8-719-107-94	DIODE 1SS202-1			
C807	1-162-294-31	CERAMIC	0.001MF	10%	50V	D502	8-719-107-94	DIODE 1SS202-1			
C808	1-162-294-31	CERAMIC	0.001MF	10%	50V	D503	8-719-107-94	DIODE 1SS202-1			
C809	1-124-894-11	ELECT	6800MF	20%	16V	D504	8-719-107-94	DIODE 1SS202-1			
C811	1-164-159-11	CERAMIC	0.1MF		50V	D505	8-719-107-94	DIODE 1SS202-1			
C812	1-164-159-11	CERAMIC	0.1MF		50V	D506	8-719-107-94	DIODE 1SS202-1			
C813	1-124-927-11	ELECT	4.7MF	20%	50V	D507	8-719-107-94	DIODE 1SS202-1			
C814	1-124-477-11	ELECT	47MF	20%	16V	D508	8-719-107-94	DIODE 1SS202-1			
C815	1-124-477-11	ELECT	47MF	20%	16V	D701	8-719-200-77	DIODE 10E2N			
C816	1-123-875-11	ELECT	10MF	20%	50V	D702	8-719-200-77	DIODE 10E2N			
C817	1-123-875-11	ELECT	10MF	20%	50V	D703	8-719-200-77	DIODE 10E2N			
C818	1-123-382-00	ELECT	3.3MF	20%	50V	D704	8-719-200-77	DIODE 10E2N			
C820	1-124-927-11	ELECT	4.7MF	20%	50V	D705	8-719-200-77	DIODE 10E2N			
C821	1-124-791-11	ELECT	1MF	20%	50V	D706	8-719-200-77	DIODE 10E2N			
C822	1-164-159-11	CERAMIC	0.1MF		50V	D707	8-719-107-94	DIODE 1SS202-1			
C823	1-164-159-11	(US,Canadian) ...CERAMIC	0.1MF		50V	D708	8-719-933-33	DIODE HZS6A1L			

Ref.No.	Part No.	Description
D709	8-719-933-33	DIODE HZS6A1L
D710	8-719-933-39	DIODE HZS6C1L
D711	8-719-200-77	DIODE 10E2N
D712	8-719-200-77	DIODE 10E2N
D713	8-719-000-93	DIODE UZL-7H1
D715	8-719-107-94	DIODE 1SS202-1
D716	8-719-109-74	DIODE RD4.3ES-B1
D717	8-719-107-94	DIODE 1SS202-1
D718	8-719-933-39	DIODE HZS6C1L
D719	8-719-107-94	DIODE 1SS202-1
D720	8-719-200-77	DIODE 10E2N
D801	8-719-107-94	DIODE 1SS202-1
D802	8-719-107-94	DIODE 1SS202-1
D803	8-719-107-94	DIODE 1SS202-1
D804	8-719-107-94	DIODE 1SS202-1
D805	8-719-107-94	DIODE 1SS202-1
D806	8-719-107-94	DIODE 1SS202-1
D807	8-719-107-94	DIODE 1SS202-1
D808	8-719-001-21	DIODE UZL-9H1
D809	8-719-001-21	DIODE UZL-9H1
D810	8-719-933-54	DIODE HZS9A2L
D811	8-719-933-54	DIODE HZS9A2L
D812	8-719-107-94	DIODE 1SS202-1
D813	8-719-107-94	DIODE 1SS202-1
D814	8-719-107-94	DIODE 1SS202-1
D815	8-719-107-94	DIODE 1SS202-1
D816	8-719-107-94	DIODE 1SS202-1
D817	8-719-107-94	DIODE 1SS202-1
D818	8-719-107-94	DIODE 1SS202-1
D819	8-719-107-94	(US,Canadian)...DIODE 1SS202-1
D820	8-719-107-94	DIODE 1SS202-1
D821	8-719-200-77	DIODE 10E2N
D901	8-719-107-94	DIODE 1SS202-1
D902	8-719-107-94	DIODE 1SS202-1
D903	8-719-107-94	DIODE 1SS202-1
D904	8-719-107-94	DIODE 1SS202-1
D905	8-719-302-45	DIODE SEL1210S
D906	8-719-302-45	DIODE SEL1210S
D907	8-719-302-45	DIODE SEL1210S
D908	8-719-301-44	DIODE SEL2410E-D
D909	8-719-301-59	DIODE SEL2910A
D910	8-719-301-38	DIODE SEL2210S-C
D911	8-719-301-59	DIODE SEL2910A
D912	8-719-301-59	DIODE SEL2910A
D913	8-719-301-38	DIODE SEL2210S-C
D914	8-719-303-33	DIODE SEL4214W
FLT901	1-519-493-11	INDICATOR TUBE, FLUORESCENT
HRPE1001	A-2003-533-A	SLIDER COMPLETE ASSY
IC501	8-759-111-44	IC UPC4570C-1
IC502	8-752-036-34	IC CXA1330S
IC503	8-752-038-02	IC CXA1198AP
IC504	8-759-106-56	IC UPC1297CA
IC505	8-759-945-58	IC RC4558P
IC506	8-759-945-58	IC RC4558P

Ref.No.	Part No.	Description
IC651	8-759-634-51	IC M5218AP
IC652	8-759-634-50	IC M5218AL
IC701	8-759-945-58	IC RC4558P
IC801	8-759-634-80	IC M50963-225SP
IC802	8-759-240-69	IC TC4069UBP
IC803	8-759-973-95	IC BA6219B
IC804	8-759-822-09	IC LB1641
IC805	8-759-945-58	IC RC4558P
IC806	8-759-945-58	IC RC4558P
IC807	8-759-140-00	(US,Canadian)...IC UPD4011BC
IC901	8-759-983-68	IC MB88517B-1023N
IC902	8-741-100-48	IC SBX1610-59
IC1001	8-749-920-97	PHOTO REFLECTOR GP2S22B
IC1002	8-749-920-97	PHOTO REFLECTOR GP2S22B
J101	1-507-854-00	(AEP)...JACK, LARGE TYPE (MICROPHONE LEFT)
J101	1-507-854-21	(US,Canadian,UK)...JACK, LARGE TYPE (MICROPHONE LEFT)
J301	1-507-854-00	(AEP)...JACK, LARGE TYPE (MICROPHONE RIGHT)
J301	1-507-854-21	(US,Canadian,UK)...JACK, LARGE TYPE (MICROPHONE RIGHT)
J501A	1-507-796-71	JACK (HEADPHONES)
J501B	1-565-258-11	JACK, PIN 4P (LINE IN/OUT)
L101	1-410-780-11	INDUCTOR 27MMH
L301	1-410-780-11	INDUCTOR 27MMH
L501	1-408-080-00	INDUCTOR 100UH
LPF101	1-236-475-11	FILTER, LOW PASS
LPF301	1-236-475-11	FILTER, LOW PASS
M1051	X-3356-638-1	MOTOR (REEL R) ASSY
M1052	X-3356-604-1	MOTOR (ASSIST) ASSY
M1053	X-3356-635-1	MOTOR (CAPSTAN R2) ASSY
PT101A	1-450-018-11	(US,Canadian)...TRANSFORMER, POWER
PT101B	1-450-019-11	(AEP,UK).....TRANSFORMER, POWER
Q101	8-729-900-74	TRANSISTOR DTC143TS
Q102	8-729-900-80	TRANSISTOR DTC114ES
Q103	8-729-142-25	TRANSISTOR 2SD1020-HFE
Q104	8-729-620-05	TRANSISTOR 2SC2603-EF
Q301	8-729-900-74	TRANSISTOR DTC143TS
Q302	8-729-900-80	TRANSISTOR DTC114ES
Q303	8-729-142-25	TRANSISTOR 2SD1020-HFE
Q304	8-729-620-05	TRANSISTOR 2SC2603-EF
Q501	8-729-821-04	TRANSISTOR 2SA1317-STU
Q502	8-729-900-80	TRANSISTOR DTC114ES
Q503	8-729-900-80	TRANSISTOR DTC114ES
Q504	8-729-900-80	TRANSISTOR DTC114ES
Q505	8-729-821-04	TRANSISTOR 2SA1317-STU
Q506	8-729-900-80	TRANSISTOR DTC114ES
Q507	8-729-900-80	TRANSISTOR DTC114ES
Q508	8-729-900-80	TRANSISTOR DTC114ES
Q510	8-729-194-57	TRANSISTOR 2SC945-P
Q511	8-729-194-57	TRANSISTOR 2SC945-P
Q701	8-729-900-80	TRANSISTOR DTC114ES
Q702	8-729-920-97	TRANSISTOR 2SB1187-EF
Q703	8-729-920-98	TRANSISTOR 2SD1761-EF

Note:

The components identified by mark Δ or dotted line with mark Δ are critical for safety. Replace only with part number specified.

Note:

Les composants identifiés par une marque Δ sont critiques pour la sécurité. Ne les remplacer que par une pièce portant le numéro spécifié.

Ref.No.	Part No.	Description
Q704	8-729-620-05	TRANSISTOR 2SC2603-EF
Q705	8-729-920-97	TRANSISTOR 2SB1187-EF
Q706	8-729-821-04	TRANSISTOR 2SA1317-STU
Q707	8-729-140-04	TRANSISTOR 2SB1116A-L
Q708	8-729-900-61	TRANSISTOR DTA114ES
Q709	8-729-900-80	TRANSISTOR DTC114ES
Q710	8-729-900-65	TRANSISTOR DTA114ES
Q801	8-729-900-61	TRANSISTOR DTA114ES
Q802	8-729-900-61	TRANSISTOR DTA114ES
Q803	8-729-900-61	TRANSISTOR DTA114ES
Q804	8-729-900-61	TRANSISTOR DTA114ES
Q805	8-729-900-61	TRANSISTOR DTA114ES
Q806	8-729-900-61	TRANSISTOR DTA114ES
Q807	8-729-900-61	TRANSISTOR DTA114ES
Q808	8-729-620-05	TRANSISTOR 2SC2603-EF
Q809	8-729-620-05	TRANSISTOR 2SC2603-EF
Q810	8-729-900-61	TRANSISTOR DTA114ES
Q811	8-729-900-61	TRANSISTOR DTA114ES
Q812	8-729-900-61	TRANSISTOR DTA114ES
Q813	8-729-900-61	TRANSISTOR DTA114ES
Q814	8-729-900-61	TRANSISTOR DTA114ES
Q815	8-729-900-61	TRANSISTOR DTA114ES
Q816	8-729-900-80	TRANSISTOR DTC114ES
Q817	8-729-821-04	TRANSISTOR 2SA1317-STU
Q818	8-729-900-80	TRANSISTOR DTC114ES
Q819	8-729-821-04	TRANSISTOR 2SA1317-STU
Q820	8-729-900-80	TRANSISTOR DTC114ES
Q821	8-729-620-05	TRANSISTOR 2SC2603-EF
Q822	8-729-900-61	TRANSISTOR DTA114ES
Q823	8-729-620-05	TRANSISTOR 2SC2603-EF
Q824	8-729-801-93	TRANSISTOR 2SD1387
Q825	8-729-801-84	TRANSISTOR 2SB1013-4
Q826	8-729-801-84	TRANSISTOR 2SB1013-4
Q827	8-729-801-93	TRANSISTOR 2SD1387
Q828	8-729-801-93	TRANSISTOR 2SD1387
Q829	8-729-900-61	TRANSISTOR DTA114ES
Q830	8-729-620-05	TRANSISTOR 2SC2603-EF
Q831	8-729-620-05	TRANSISTOR 2SC2603-EF
Q901	8-729-900-61	TRANSISTOR DTA114ES
Q902	8-729-900-61	TRANSISTOR DTA114ES
Q903	8-729-900-80	TRANSISTOR DTC114ES
Q904	8-729-900-61	TRANSISTOR DTA114ES
Q905	8-729-900-80	TRANSISTOR DTC114ES
Q906	8-729-900-61	TRANSISTOR DTA114ES
R101	1-249-433-11	CARBON 22K 5% 1/4W
R102	1-247-887-00	CARBON 220K 5% 1/4W
R103	1-249-423-11	CARBON 3.3K 5% 1/4W
R104	1-249-428-11	CARBON 8.2K 5% 1/4W
R105	1-247-864-11	CARBON 24K 5% 1/4W
R106	1-249-414-11	CARBON 560 5% 1/4W
R107	1-249-421-11	CARBON 2.2K 5% 1/4W
R108	1-249-428-11	CARBON 8.2K 5% 1/4W
R109	1-249-421-11	CARBON 2.2K 5% 1/4W
R110	1-249-417-11	CARBON 1K 5% 1/4W
R111	1-249-429-11	CARBON 10K 5% 1/4W
R112	1-249-425-11	CARBON 4.7K 5% 1/4W

Ref.No.	Part No.	Description
R113	1-249-421-11	CARBON 2.2K 5% 1/4W
R114	1-249-429-11	CARBON 10K 5% 1/4W
R115	1-249-421-11	CARBON 2.2K 5% 1/4W
R116	1-249-428-11	CARBON 8.2K 5% 1/4W
R117	1-249-435-11	CARBON 33K 5% 1/4W
R118	1-249-403-11	CARBON 68 5% 1/4W
R119	1-247-882-11	CARBON 130K 5% 1/4W
R120	1-249-426-11	CARBON 5.6K 5% 1/4W
R121	1-249-421-11	CARBON 2.2K 5% 1/4W
R122	1-249-421-11	CARBON 2.2K 5% 1/4W
R123	1-247-840-00	CARBON 2.4K 5% 1/4W
R124	1-247-887-00	CARBON 220K 5% 1/4W
R125	1-249-421-11	CARBON 2.2K 5% 1/4W
R126	1-249-429-11	CARBON 10K 5% 1/4W
R127	1-249-432-11	CARBON 18K 5% 1/4W
R128	1-249-393-11	CARBON 10 5% 1/4W
R129	1-247-883-00	CARBON 150K 5% 1/4W
R130	1-249-434-11	CARBON 27K 5% 1/4W
R131	1-249-431-11	CARBON 15K 5% 1/4W
R132	1-247-868-11	CARBON 36K 5% 1/4W
R133	1-249-408-11	CARBON 180 5% 1/4W
R232	1-247-868-11	CARBON 36K 5% 1/4W
R251	1-249-429-11	CARBON 10K 5% 1/4W
R252	1-249-421-11	CARBON 2.2K 5% 1/4W
R253	1-249-421-11	CARBON 2.2K 5% 1/4W
R254	1-249-409-11	CARBON 220 5% 1/4W
R255	1-249-441-11	CARBON 100K 5% 1/4W
R256	1-249-429-11	CARBON 10K 5% 1/4W
R257	1-249-437-11	CARBON 47K 5% 1/4W
R258	1-249-411-11	CARBON 330 5% 1/4W
R259	1-249-441-11	CARBON 100K 5% 1/4W
R301	1-249-433-11	CARBON 22K 5% 1/4W
R302	1-247-887-00	CARBON 220K 5% 1/4W
R303	1-249-423-11	CARBON 3.3K 5% 1/4W
R304	1-249-428-11	CARBON 8.2K 5% 1/4W
R305	1-247-864-11	CARBON 24K 5% 1/4W
R306	1-249-414-11	CARBON 560 5% 1/4W
R307	1-249-421-11	CARBON 2.2K 5% 1/4W
R308	1-249-428-11	CARBON 8.2K 5% 1/4W
R309	1-249-421-11	CARBON 2.2K 5% 1/4W
R310	1-249-417-11	CARBON 1K 5% 1/4W
R311	1-249-429-11	CARBON 10K 5% 1/4W
R312	1-249-425-11	CARBON 4.7K 5% 1/4W
R313	1-249-421-11	CARBON 2.2K 5% 1/4W
R314	1-249-429-11	CARBON 10K 5% 1/4W
R315	1-249-421-11	CARBON 2.2K 5% 1/4W
R316	1-249-428-11	CARBON 8.2K 5% 1/4W
R317	1-249-435-11	CARBON 33K 5% 1/4W
R318	1-249-403-11	CARBON 68 5% 1/4W
R319	1-247-882-11	CARBON 130K 5% 1/4W
R320	1-249-426-11	CARBON 5.6K 5% 1/4W
R321	1-249-421-11	CARBON 2.2K 5% 1/4W
R322	1-249-421-11	CARBON 2.2K 5% 1/4W
R323	1-247-840-00	CARBON 2.4K 5% 1/4W
R324	1-247-887-00	CARBON 220K 5% 1/4W
R325	1-249-421-11	CARBON 2.2K 5% 1/4W
R326	1-249-429-11	CARBON 10K 5% 1/4W
R327	1-249-432-11	CARBON 18K 5% 1/4W



Ref.No.	Part No.	Description				Ref.No.	Part No.	Description			
R328	1-249-393-11	CARBON	10	5%	1/4W	R547	1-249-429-11	CARBON	10K	5%	1/4W
R329	1-247-883-00	CARBON	150K	5%	1/4W	R548	1-249-428-11	CARBON	8.2K	5%	1/4W
R330	1-249-434-11	CARBON	27K	5%	1/4W	R549	1-249-441-11	CARBON	100K	5%	1/4W
R331	1-249-431-11	CARBON	15K	5%	1/4W						
R332	1-247-868-11	CARBON	36K	5%	1/4W	R550	1-249-441-11	CARBON	100K	5%	1/4W
R333	1-249-408-11	CARBON	180	5%	1/4W	R551	1-249-423-11	CARBON	3.3K	5%	1/4W
R451	1-249-429-11	CARBON	10K	5%	1/4W	R552	1-249-429-11	CARBON	10K	5%	1/4W
R452	1-249-421-11	CARBON	2.2K	5%	1/4W	R553	1-249-429-11	CARBON	10K	5%	1/4W
R453	1-249-421-11	CARBON	2.2K	5%	1/4W	R554	1-249-417-11	CARBON	1K	5%	1/4W
R454	1-249-409-11	CARBON	220	5%	1/4W	R555	1-249-430-11	CARBON	12K	5%	1/4W
R455	1-249-441-11	CARBON	100K	5%	1/4W	R556	1-249-435-11	CARBON	33K	5%	1/4W
R456	1-249-429-11	CARBON	10K	5%	1/4W	R651	1-249-409-11	CARBON	220	5%	1/4W
R457	1-249-437-11	CARBON	47K	5%	1/4W	R652	1-249-409-11	CARBON	220	5%	1/4W
R458	1-249-411-11	CARBON	330	5%	1/4W	R653	1-249-413-11	CARBON	470	5%	1/4W
R459	1-249-441-11	CARBON	100K	5%	1/4W	R654	1-249-413-11	CARBON	470	5%	1/4W
R501	1-249-417-11	CARBON	1K	5%	1/4W	R701	1-249-426-11	CARBON	5.6K	5%	1/4W
R502	1-249-441-11	CARBON	100K	5%	1/4W	R702	1-249-425-11	CARBON	4.7K	5%	1/4W
R503	1-249-403-11	CARBON	68	5%	1/4W	R703	1-249-421-11	CARBON	2.2K	5%	1/4W
R504	1-249-429-11	CARBON	10K	5%	1/4W	R704	1-249-425-11	CARBON	4.7K	5%	1/4W
R505	1-249-434-11	CARBON	27K	5%	1/4W	R705	1-249-427-11	CARBON	6.8K	5%	1/4W
R506	1-249-421-11	CARBON	2.2K	5%	1/4W	R706	1-249-419-11	CARBON	1.5K	5%	1/4W
R507	1-249-417-11	CARBON	1K	5%	1/4W	R707	1-247-856-00	CARBON	11K	5%	1/4W
R508	1-249-441-11	CARBON	100K	5%	1/4W	R708	1-249-419-11	CARBON	1.5K	5%	1/4W
R509	1-247-864-11	CARBON	24K	5%	1/4W	R709	1-249-425-11	CARBON	4.7K	5%	1/4W
R512	1-247-870-11	CARBON	43K	5%	1/4W	R710	1-249-409-11	CARBON	220	5%	1/4W
R513	1-249-436-11	CARBON	39K	5%	1/4W	R711	1-249-427-11	CARBON	6.8K	5%	1/4W
R514	1-247-882-11	CARBON	130K	5%	1/4W	R712	1-249-427-11	CARBON	6.8K	5%	1/4W
R515	1-247-885-00	CARBON	180K	5%	1/4W	R713	1-249-417-11	CARBON	1K	5%	1/4W
R516	1-249-436-11	CARBON	39K	5%	1/4W	R714	1-247-887-00	CARBON	220K	5%	1/4W
R517	1-249-438-11	CARBON	56K	5%	1/4W	R715	1-249-417-11	CARBON	1K	5%	1/4W
R518	1-247-874-11	CARBON	62K	5%	1/4W	R716	1-249-427-11	CARBON	6.8K	5%	1/4W
R519	1-247-872-11	CARBON	51K	5%	1/4W	R717	1-249-429-11	CARBON	10K	5%	1/4W
R520	1-247-891-00	CARBON	330K	5%	1/4W	R718	1-249-441-11	CARBON	100K	5%	1/4W
R521	1-247-887-00	CARBON	220K	5%	1/4W	R719	1-249-433-11	CARBON	22K	5%	1/4W
R522	1-249-435-11	CARBON	33K	5%	1/4W	R720	1-249-429-11	CARBON	10K	5%	1/4W
R523	1-247-893-11	CARBON	390K	5%	1/4W	R721	1-249-434-11	CARBON	27K	5%	1/4W
R524	1-247-874-11	CARBON	62K	5%	1/4W	R722	1-249-417-11	CARBON	1K	5%	1/4W
R525	1-249-438-11	CARBON	56K	5%	1/4W	R723	1-249-430-11	CARBON	12K	5%	1/4W
R526	1-249-440-11	CARBON	82K	5%	1/4W	R724	1-249-408-11	CARBON	180	5%	1/4W
R527	1-247-878-00	CARBON	91K	5%	1/4W	R725	△.1-219-136-11	FUSIBLE	0.22	10%	1/4W F
R528	1-247-872-11	CARBON	51K	5%	1/4W	R726	△.1-219-136-11	FUSIBLE	0.22	10%	1/4W F
R529	1-247-885-00	CARBON	180K	5%	1/4W	R728	1-249-414-11	CARBON	560	5%	1/4W
R530	1-249-409-11	CARBON	220	5%	1/4W	R750	1-249-441-11	(US,Canadian)...CARBON	100K	5%	1/4W
R531	1-249-409-11	CARBON	220	5%	1/4W	R751	1-249-405-11	(US,Canadian)...CARBON	100	5%	1/4W
R532	1-249-429-11	CARBON	10K	5%	1/4W	R752	1-249-429-11	(US,Canadian)...CARBON	10K	5%	1/4W
R533	1-249-429-11	CARBON	10K	5%	1/4W	R753	1-249-429-11	(US,Canadian)...CARBON	10K	5%	1/4W
R534	1-249-421-11	CARBON	2.2K	5%	1/4W	R754	1-249-429-11	(US,Canadian)...CARBON	10K	5%	1/4W
R535	1-249-419-11	CARBON	1.5K	5%	1/4W	R755	1-249-429-11	(US,Canadian)...CARBON	10K	5%	1/4W
R536	1-247-848-11	CARBON	5.1K	5%	1/4W	R756	1-249-393-11	(US,Canadian)...CARBON	10	5%	1/4W
R538	1-249-441-11	CARBON	100K	5%	1/4W	R801	1-249-411-11	CARBON	330	5%	1/4W
R539	1-249-437-11	CARBON	47K	5%	1/4W	R802	1-249-429-11	CARBON	10K	5%	1/4W
R540	1-249-437-11	CARBON	47K	5%	1/4W	R803	1-249-429-11	CARBON	10K	5%	1/4W
R541	1-249-389-11	CARBON	4.7	5%	1/4W	R804	1-249-429-11	CARBON	10K	5%	1/4W
R542	1-249-389-11	CARBON	4.7	5%	1/4W	R805	1-249-410-11	CARBON	270	5%	1/4W
R543	1-249-409-11	CARBON	220	5%	1/4W	R806	1-249-410-11	CARBON	270	5%	1/4W
R544	1-249-409-11	CARBON	220	5%	1/4W	R807	1-249-409-11	CARBON	220	5%	1/4W
R545	1-249-441-11	CARBON	100K	5%	1/4W	R808	1-249-411-11	CARBON	330	5%	1/4W
R546	1-249-441-11	CARBON	100K	5%	1/4W	R809	1-249-410-11	CARBON	270	5%	1/4W
						R810	1-249-413-11	CARBON	470	5%	1/4W

Note:
The components identified by mark Δ or dotted line with mark Δ are critical for safety. Replace only with part number specified.

Note:
Les composants identifiés par une marque Δ sont critiques pour la sécurité. Ne les remplacer que par une pièce portant le numéro spécifié.

Ref.No.	Part No.	Description			
R811	1-249-435-11	CARBON	33K	5%	1/4W
R812	1-249-433-11	CARBON	22K	5%	1/4W
R813	1-249-433-11	CARBON	22K	5%	1/4W
R814	1-249-425-11	CARBON	4.7K	5%	1/4W
R815	1-249-417-11	CARBON	1K	5%	1/4W
R816	1-249-435-11	CARBON	33K	5%	1/4W
R817	1-249-435-11	CARBON	33K	5%	1/4W
R818	1-247-903-00	CARBON	1M	5%	1/4W
R819	1-249-417-11	CARBON	1K	5%	1/4W
R820	1-249-414-11	CARBON	560	5%	1/4W
R821	1-249-417-11	CARBON	1K	5%	1/4W
R822	1-249-429-11	CARBON	10K	5%	1/4W
R823	1-249-429-11	CARBON	10K	5%	1/4W
R824	1-249-433-11	CARBON	22K	5%	1/4W
R825	1-249-429-11	CARBON	10K	5%	1/4W
R826	1-249-421-11	CARBON	2.2K	5%	1/4W
R827	1-249-410-11	CARBON	270	5%	1/4W
R828	1-249-441-11	CARBON	100K	5%	1/4W
R829	1-249-419-11	CARBON	1.5K	5%	1/4W
R830	1-249-421-11	CARBON	2.2K	5%	1/4W
R836	1-249-429-11	CARBON	10K	5%	1/4W
R837	1-249-429-11	CARBON	10K	5%	1/4W
R838	1-249-429-11	CARBON	10K	5%	1/4W
R839	1-249-429-11	CARBON	10K	5%	1/4W
R840	1-249-433-11	CARBON	22K	5%	1/4W
R841	1-249-433-11	CARBON	22K	5%	1/4W
R842	1-249-429-11	CARBON	10K	5%	1/4W
R843	1-249-429-11	CARBON	10K	5%	1/4W
R844	1-249-429-11	CARBON	10K	5%	1/4W
R845	1-249-429-11	CARBON	10K	5%	1/4W
R846	1-249-436-11	CARBON	39K	5%	1/4W
R847	1-247-887-00	CARBON	220K	5%	1/4W
R848	1-249-436-11	CARBON	39K	5%	1/4W
R849	1-247-887-00	CARBON	220K	5%	1/4W
R850	1-247-887-00	CARBON	220K	5%	1/4W
R851	1-247-887-00	CARBON	220K	5%	1/4W
R852	1-249-430-11	CARBON	12K	5%	1/4W
R853	1-249-429-11	CARBON	10K	5%	1/4W
R854	1-247-854-11	CARBON	9.1K	5%	1/4W
R855	1-249-429-11	CARBON	10K	5%	1/4W
R856	1-249-423-11	CARBON	3.3K	5%	1/4W
R857	1-247-858-11	CARBON	13K	5%	1/4W
R858	1-249-432-11	CARBON	18K	5%	1/4W
R859	△.1-212-952-00	FUSIBLE	5.6	5%	1/2W F
R860	△.1-212-954-11	FUSIBLE	6.8	5%	1/2W F
R861	1-249-408-11	CARBON	180	5%	1/4W
R862	1-249-408-11	CARBON	180	5%	1/4W
R863	1-249-408-11	CARBON	180	5%	1/4W
R864	1-249-421-11	CARBON	2.2K	5%	1/4W
R865	1-249-431-11	CARBON	15K	5%	1/4W
R866	1-249-429-11	CARBON	10K	5%	1/4W
R867	1-249-409-11	CARBON	220	5%	1/4W
R868	1-249-409-11	CARBON	220	5%	1/4W
R869	1-249-433-11	CARBON	22K	5%	1/4W
R870	1-249-434-11	CARBON	27K	5%	1/4W
R871	1-249-433-11	CARBON	22K	5%	1/4W
R872	1-247-866-11	CARBON	30K	5%	1/4W

Ref.No.	Part No.	Description			
R873	1-249-408-11	CARBON	180	5%	1/4W
R874	1-249-433-11	CARBON	22K	5%	1/4W
R875	1-249-434-11	CARBON	27K	5%	1/4W
R876	1-249-433-11	CARBON	22K	5%	1/4W
R877	1-247-866-11	CARBON	30K	5%	1/4W
R878	1-249-408-11	CARBON	180	5%	1/4W
R879	1-249-429-11	CARBON	10K	5%	1/4W
R881	1-249-417-11	CARBON	1K	5%	1/4W
R882	1-249-409-11	CARBON	220	5%	1/4W
R883	1-249-429-11	CARBON	10K	5%	1/4W
R884	1-249-417-11	CARBON	1K	5%	1/4W
R885	1-249-417-11	CARBON	1K	5%	1/4W
R886	1-249-417-11	CARBON	1K	5%	1/4W
R887	1-249-417-11	CARBON	1K	5%	1/4W
R888	1-249-417-11	CARBON	1K	5%	1/4W
R889	1-216-349-00	CARBON	1	5%	1/2W
R890	1-249-429-11	CARBON	10K	5%	1/4W
R891	1-249-432-11	CARBON	18K	5%	1/4W
R892	1-249-417-11	CARBON	1K	5%	1/4W
R893	1-249-429-11	CARBON	10K	5%	1/4W
R894	1-249-411-11	CARBON	330	5%	1/4W
R895	1-247-887-00	CARBON	220K	5%	1/4W
R896	1-249-421-11	CARBON	2.2K	5%	1/4W
R897	1-249-413-11	CARBON	470	5%	1/4W
R901	1-247-903-00	CARBON	1M	5%	1/4W
R902	1-249-417-11	CARBON	1K	5%	1/4W
R903	1-249-429-11	CARBON	10K	5%	1/4W
R904	1-249-441-11	CARBON	100K	5%	1/4W
R905	1-249-441-11	CARBON	100K	5%	1/4W
R906	1-249-417-11	CARBON	1K	5%	1/4W
R907	1-249-441-11	CARBON	100K	5%	1/4W
R908	1-249-441-11	CARBON	100K	5%	1/4W
R909	1-249-441-11	CARBON	100K	5%	1/4W
R910	1-249-425-11	CARBON	4.7K	5%	1/4W
R911	1-249-416-11	CARBON	820	5%	1/4W
R912	1-249-422-11	CARBON	2.7K	5%	1/4W
R913	1-249-424-11	CARBON	3.9K	5%	1/4W
R914	1-249-428-11	CARBON	8.2K	5%	1/4W
R915	1-249-434-11	CARBON	27K	5%	1/4W
R916	1-249-422-11	CARBON	2.7K	5%	1/4W
R917	1-249-424-11	CARBON	3.9K	5%	1/4W
R918	1-249-422-11	CARBON	2.7K	5%	1/4W
R919	1-249-424-11	CARBON	3.9K	5%	1/4W
R920	1-249-428-11	CARBON	8.2K	5%	1/4W
R921	1-249-429-11	CARBON	10K	5%	1/4W
R922	1-249-429-11	CARBON	10K	5%	1/4W
R923	1-249-441-11	CARBON	100K	5%	1/4W
R938	1-249-429-11	CARBON	10K	5%	1/4W
R939	1-249-441-11	CARBON	100K	5%	1/4W
R940	1-249-441-11	CARBON	100K	5%	1/4W
R1001	1-249-408-11	CARBON	180	5%	1/4W
R1002	1-249-408-11	CARBON	180	5%	1/4W
R1051	1-249-414-11	CARBON	560	5%	1/4W

Note:
The components identified by mark  or dotted line with mark  are critical for safety. Replace only with part number specified.

Note:
Les composants identifiés par une marque  sont critiques pour la sécurité. Ne les remplacer que par une pièce portant le numéro spécifié.

Ref.No.	Part No.	Description
RV101	1-238-016-11	RES, ADJ, CARBON 10K (PB LEVEL L-CH)
RV102	1-238-016-11	RES, ADJ, CARBON 10K (REC LEVEL L-CH)
RV103	1-238-017-11	RES, ADJ, CARBON 22K (BIAS L-CH)
RV301	1-238-016-11	RES, ADJ, CARBON 10K (PB LEVEL R-CH)
RV302	1-238-016-11	RES, ADJ, CARBON 10K (REC LEVEL R-CH)
RV303	1-238-017-11	RES, ADJ, CARBON 22K (BIAS R-CH)
RV501	1-238-905-11	RES, VAR, CARBON 50K/50K/20K(REC LEVEL)
RV502	1-238-904-11	RES, VAR, CARBON 50K/50K (BALANCE)
RV801	1-238-019-11	RES, ADJ, CARBON 47K (QUICK REV)
RY801	1-515-683-11	RELAY
S501	1-572-154-11	SWITCH, ROTARY (DOLBY NR)
S502	1-571-305-11	SWITCH, PUSH (1 KEY)(MPX FILTER)
S701	1-571-305-11	SWITCH, PUSH (1 KEY)(POWER)
S801	1-571-520-11	SWITCH, SLIDE (DIRECTION MODE)
S802	1-571-520-11	SWITCH, SLIDE (TIMER)
S901	1-554-303-21	SWITCH, KEY BOARD (OPEN/CLOSE)
S902	1-554-303-21	SWITCH, KEY BOARD (■)
S903	1-554-303-21	SWITCH, KEY BOARD (◀)
S904	1-554-303-21	SWITCH, KEY BOARD (▶▶)
S905	1-554-303-21	SWITCH, KEY BOARD (REC)
S906	1-554-303-21	SWITCH, KEY BOARD (►)
S907	1-554-303-21	SWITCH, KEY BOARD (◀)
S908	1-554-303-21	SWITCH, KEY BOARD (REC MUTE)
S909	1-554-303-21	SWITCH, KEY BOARD (PAUSE)
S910	1-554-303-21	SWITCH, KEY BOARD (DISPLAY MODE)
S911	1-554-303-21	SWITCH, KEY BOARD (AUTO REC LEVEL)
S912	1-554-303-21	SWITCH, KEY BOARD (FADER)
S913	1-554-303-21	SWITCH, KEY BOARD (COUNTER:RESET)
S914	1-554-303-21	SWITCH, KEY BOARD (COUNTER:MEMORY)
S1001	1-466-237-11	ENCODER, ROTARY
S1002	1-570-953-11	SWITCH, PUSH (1 KEY)(DOOR)
S1003	1-571-958-11	SWITCH, PUSH (1 KEY)(CLOSE)
S1004	1-572-126-11	SWITCH, PUSH (1 KEY)(OPEN)
S1005	1-572-125-11	SWITCH, LEAF (FWD)
S1006	1-572-202-11	SWITCH, LEAF (HALF)
S1007	1-572-125-11	SWITCH, LEAF (METAL)
S1008	1-572-125-11	SWITCH, LEAF (70US)
S1009	1-572-125-11	SWITCH, LEAF (REV)

Ref.No.	Part No.	Description
T101	1-433-335-11	TRANSFORMER, BIAS OSCILLATION
T301	1-433-335-11	TRANSFORMER, BIAS OSCILLATION
T501	1-433-336-11	TRANSFORMER, BIAS OSCILLATION
TB1001	*1-569-066-11	PIN, CONNECTOR 5P
TP501	*1-564-506-11	PLUG, CONNECTOR 3P
TP801	*1-564-505-11	PLUG, CONNECTOR 2P
TP802	*1-564-505-11	PLUG, CONNECTOR 2P
TP803	*1-564-506-11	PLUG, CONNECTOR 3P
X801	1-577-358-21	VIBRATOR, CERAMIC (4MHz)
X901	1-577-360-11	VIBRATOR, CERAMIC (6MHz)

ACCESSORY & PACKING MATERIAL

1-559-533-11	CORD, CONNECTION
*3-350-829-11	(AEP).....INDIVIDUAL CARTON
*3-350-829-21	(US,Canadian,UK)...INDIVIDUAL CARTON
*3-350-830-01	CUSHION
3-703-450-01	(US)...INSTRUCTION
3-751-465-11	(AEP).....MANUAL, INSTRUCTION
3-751-465-21	(US,Canadian)...MANUAL, INSTRUCTION
3-751-465-31	(Canadian).....MANUAL, INSTRUCTION
3-751-465-41	(AEP,Canadian)...MANUAL, INSTRUCTION

TC-RX70/RX70ES

SONY SERVICE MANUAL

US Model
Canadian Model
UK Model
TC-RX70ES
AEP Model
TC-RX70

CORRECTION-1

Correct your service manual as shown below.

 : additional part page 23

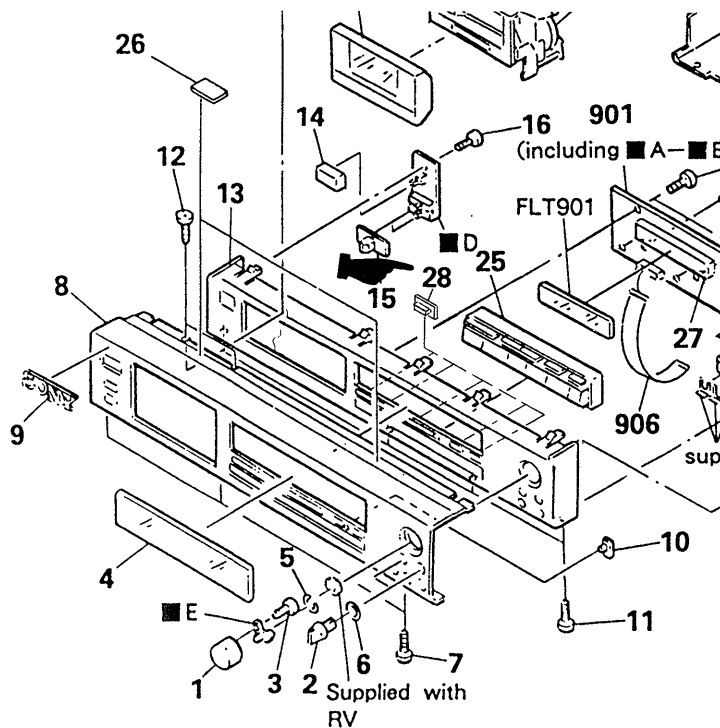

Ref. No.	Part No.	Description	Remarks
28	3-340-195-02	INDICATOR	