

TC-RX77/RX77ES

SERVICE MANUAL

US Model
Canadian Model

TC-RX77ES

AEP Model

TC-RX77



Dolby noise reduction manufactured under license from
Dolby Laboratories Licensing Corporation.
"DOLBY" and the double-D symbol $\square\square$ are trademarks of
Dolby Laboratories Licensing Corporation.

SPECIFICATIONS

Recording system	4-track 2-channel stereo
Fast-winding time	Approx. 90 sec. (with Sony C-60 cassette)
Bias	AC bias
Heads	Erasing head \times 1 (ferrite head) Playback/Recording head \times 1 (LA head)
Motors	Capstan motor \times 1 (DC servo motor) Reel motor \times 1 (DC motor) ASIST (mechanical drive) motor \times 1 (DC motor)
Signal-to-noise ratio (at peak level)	

Cassette	Dolby NR switch		
	OFF	B-Type ON	C-Type ON
Type IV (Sony METAL-SLT)	59 dB	67 dB	74 dB
Type II (Sony UX-S)	58 dB	66 dB	73 dB
Type I (Sony HF-S)	56 dB	64 dB	71 dB

Total harmonic distortion
1% (with Sony METAL-SLT cassette)
Frequency response (DOLBY NR OFF)

Type IV cassette (Sony METAL-SLT)	20-20,000Hz (\pm 3db, IEC) (US, Canadian models) 25-19,000Hz (\pm 3db, IEC) (AEP)
Type II cassette (Sony UX-S)	25-17,000 Hz (\pm 3 dB, IEC)
Type I cassette (Sony HF-S)	25-16,000 Hz (\pm 3 dB, IEC)

Wow and flutter
 \pm 0.09% W. Peak (IEC)
0.06% WRMS (NAB)
 \pm 0.16% W. Peak (DIN)

Model Name Using Similar Mechanism	TC-RX70/RX70ES
Tape Transport Mechanism Type	TCM-200R6

Inputs

Line inputs (phono jacks)	Sensitivity	77.5 mV
	Input impedance	47 k ohms
Microphone inputs (phone jacks)	Sensitivity (For a low-impedance microphone)	0.25 mV

Outputs

Line outputs (phono jacks)	Rated output level	0.32 V at a load impedance of 47 k ohms
	Load impedance	Over 10 k ohms
Headphones (stereo phone jack)	Output level	0-1.25 mW at a load impedance of 32 ohms

General

Power requirements
RX77ES : 120 V AC, 60Hz (US, Canadian models)
RX77 : 220V AC, 50/60Hz (AEP model)

Power consumption 20 W
Dimensions
Approx. 430 \times 123 \times 300 mm (w/h/d)
(17 \times 4 $\frac{7}{8}$ \times 11 $\frac{1}{8}$ inches)
including projecting parts and controls

Weight
Approx. 4.7 kg (10 lbs 6 oz)

Supplied accessory

Audio connecting cords (2)



Design and specifications subject to change without notice.

STEREO CASSETTE DECK
SONY[®]

TABLE OF CONTENTS

<u>Section</u>	<u>Title</u>	<u>Page</u>
Specification	1
Model Identification	2
Safety Check-Out	2
1. GENERAL	3
2. DISASSEMBLY	4
3. ADJUSTMENTS	7
3-1. Mechanical Adjustment	7
3-2. Electrical Adjustment	7
4. DIAGRAMS
4-1. Semiconductor Lead Layout	11
4-2. Circuit Boards Location	11
4-3. Printed Wiring Boards	12
4-4. Schematic Diagram	17
5. EXPLODED VIEWS	19
5-1. Front Panel Section	23
5-2. Chassis Section	24
5-3. Mechanism Section (TCM-200R6)	25
5-4. Mechanism Section (TCM-200R6)	26
6. ELECTRICAL PARTS LIST	27

SAFETY-RELATED COMPONENT WARNING!!

COMPONENTS IDENTIFIED BY MARK  OR DOTTED LINE WITH MARK  ON THE SCHEMATIC DIAGRAMS AND IN THE PARTS LIST ARE CRITICAL TO SAFE OPERATION. REPLACE THESE COMPONENTS WITH SONY PARTS WHOSE PART NUMBERS APPEAR AS SHOWN IN THIS MANUAL OR IN SUPPLEMENTS PUBLISHED BY SONY.

ATTENTION AU COMPOSANT AYANT RAPPORT À LA SÉCURITÉ!

LES COMPOSANTS IDENTIFIÉS PAR UNE MARQUE  SUR LES DIAGRAMMES SCHÉMATIQUES ET LA LISTE DES PIÈCES SONT CRITIQUES POUR LA SÉCURITÉ DE FONCTIONNEMENT. NE REMPLACER CES COMPOSANTS QUE PAR DES PIÈCES SONY DONT LES NUMÉROS SONT DONNÉS DANS CE MANUEL OU DANS LES SUPPLÉMENTS PUBLIÉS PAR SONY.

SAFETY CHECK-OUT

After correcting the original service problem, perform the following safety check before releasing the set to the customer:

Check the antenna terminals, metal trim, "metallized" knobs, screws, and all other exposed metal parts for AC leakage. Check leakage as described below.

LEAKAGE TEST

The AC leakage from any exposed metal part to earth ground and from all exposed metal parts to any exposed metal part having a return to chassis, must not exceed 0.5 mA (500 microamperes). Leakage current can be measured by any one of three methods.

1. A commercial leakage tester, such as the Simpson 229 or RCA WT-540A. Follow the manufacturers' instructions to use these instruments.
2. A battery-operated AC milliammeter. The Data Precision 245 digital multimeter is suitable for this job.
3. Measuring the voltage drop across a resistor by means of a VOM or battery-operated AC voltmeter. The "limit" indication is 0.75 V, so analog meters must have an accurate low-voltage scale. The Simpson 250 and Sanwa SH-63Trd are examples of a passive VOM that is suitable. Nearly all battery operated digital multimeters that have a 2V AC range are suitable. (See Fig. A)

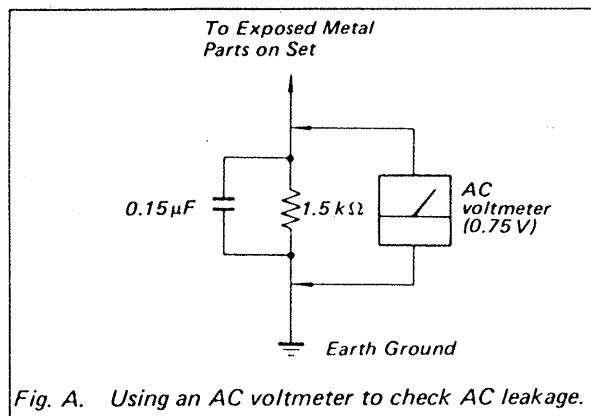
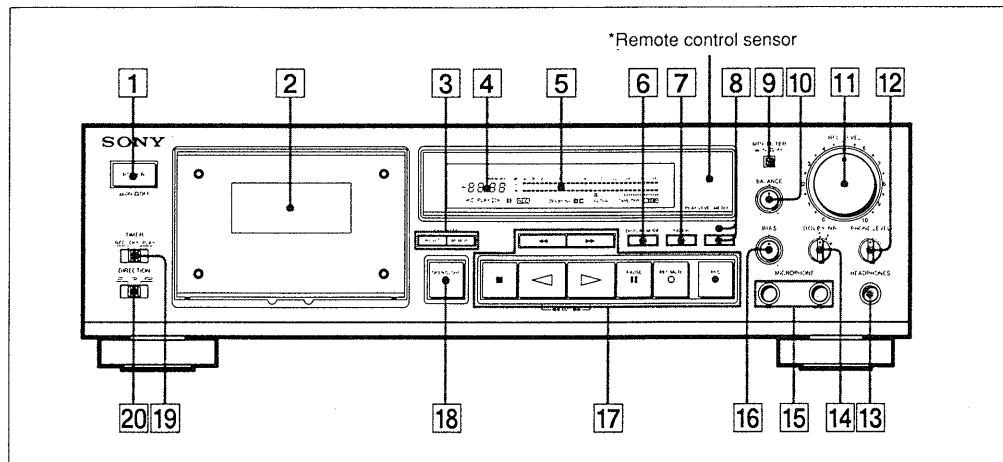

Fig. A. Using an AC voltmeter to check AC leakage.

SECTION 1 GENERAL

This section is extracted from
instruction manual.

Identification of Front Panel Parts





For details, refer to the page number indicated in ●.

- | | | |
|---|--|--|
| 1 POWER switch | 9 MPX FILTER button ● | 17 Tape operation buttons
◀ (leftward fast winding) button
▶ (rightward fast winding) button
■ (stop) button
◀ (reverse play) button
▶ (forward play) button
 PAUSE (pause) button
○ REC MUTE (record muting) button ●
● REC (record) button |
| 2 Cassette holder | 10 BALANCE control ● | 18 ▲ OPEN/CLOSE button |
| 3 Counter buttons
RESET button ●
MEMORY button ● ● | 11 REC (recording) LEVEL control ● ● | 19 TIMER switch ● |
| 4 LINEAR COUNTER ● | 12 PHONE (headphones) LEVEL control ● | 20 DIRECTION mode switch ● ● |
| 5 PEAK LEVEL METER ● | 13 HEADPHONES jack (stereo phone jack) ● | |
| 6 DISPLAY MODE button ● | 14 DOLBY NR (noise reduction switch) ● ● | |
| 7 FADER button ● | 15 MICROPHONE jacks (phone jacks) | |
| 8 ARL (automatic recording level) control and indicator ● | 16 BIAS control ● | |

*Remote control sensor

You can remotely control this cassette deck with:

- A remote commander that came with a Sony amplifier or receiver if it has the  mark and cassette deck control capability.
- An optional Sony remote commander with the  mark and cassette deck control capability.

Features

For higher quality recording/playback

- The **Dolby HX PRO*** system which improves the linearity of the tape's high-range response during recording.
- **B and C type Dolby NR*** systems which reduce tape noise.
- **Bias calibration** to achieve the optimum bias current setting for any tape.

For your convenience

- **Quick reversing** at the end of a tape to minimize interruptions during playback and recording.
- The **AMS and Memory Play** functions which provide easy access to a desired selection.
- **Automatic recording level adjustment** for one-touch protection against distortion.
- **Timer-activated playback and recording** through the use of an optional timer.
- **Automatic switching between line and microphone input** when recording with a microphone.
- **Display mode button** which allows you to select normal display, counter only or display off.

For easier operation

- **Fade-in and Fade-out** functions to start and end recordings with a professional touch.
- **Easy-to-read digital linear counter** which shows the elapsed recording or playing time.

Identification of Rear Panel Parts

LINE IN (line input) jacks

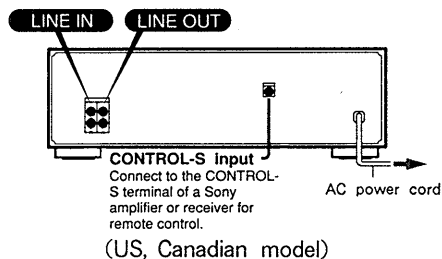

SECTION 2 DISASSEMBLY

Note: Follow the disassembly procedure
in the numerical order given.

Unscrew the four case attachment screws M3 × 8 and
remove the upper case.

MAIN BOARD

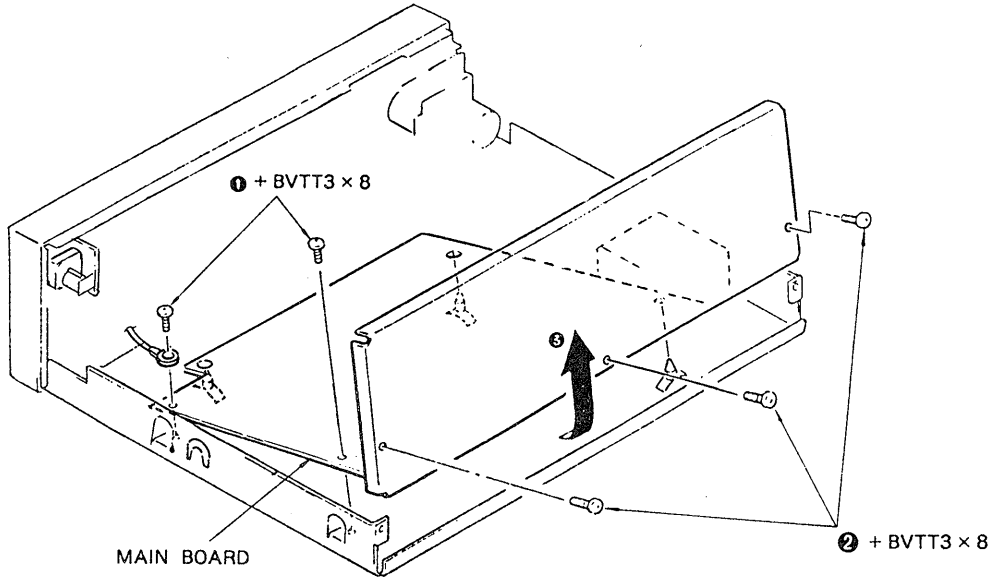

MECHANISM

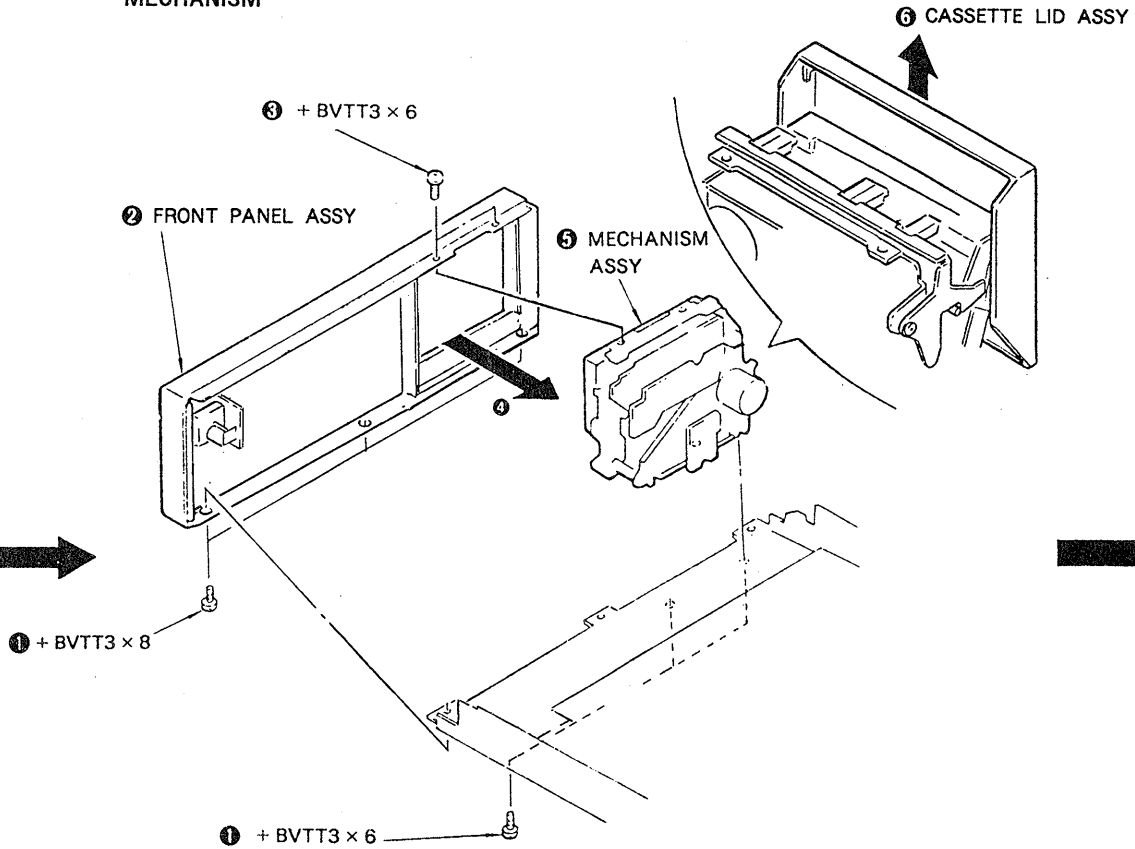

CASSETTE HOLDER

3 Push LEVER (LIFTER) in the direction of arrow and remove CASSETTE HOLDER.

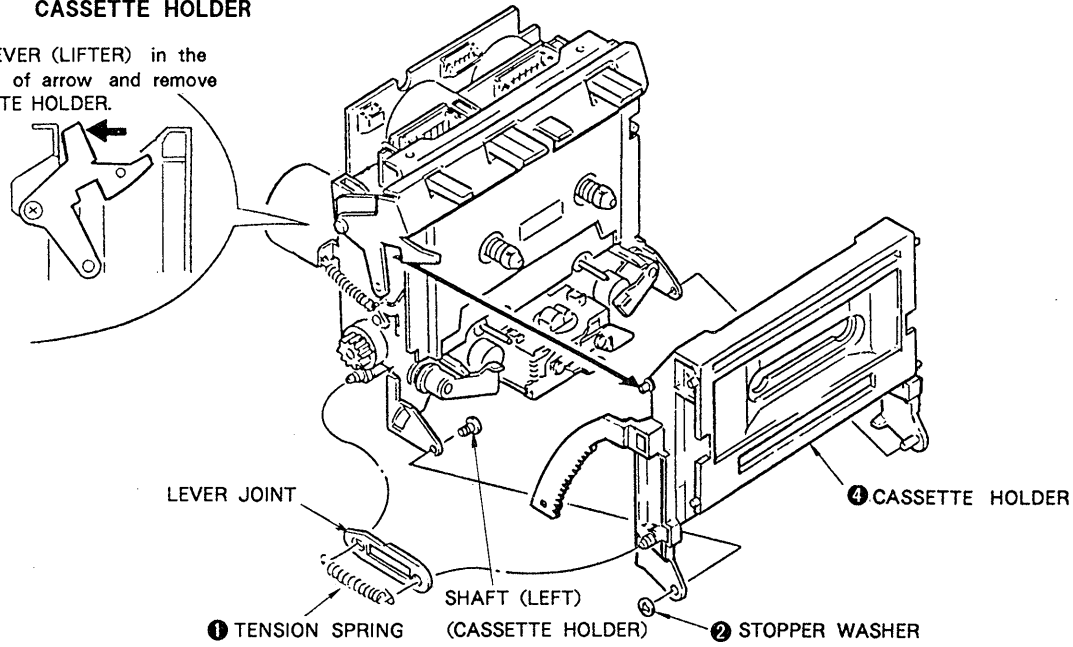

ORNAMENTAL PLATE

2 Push LEVER (LIFTER) in the direction of arrow and remove ORNAMENTAL PLATE.

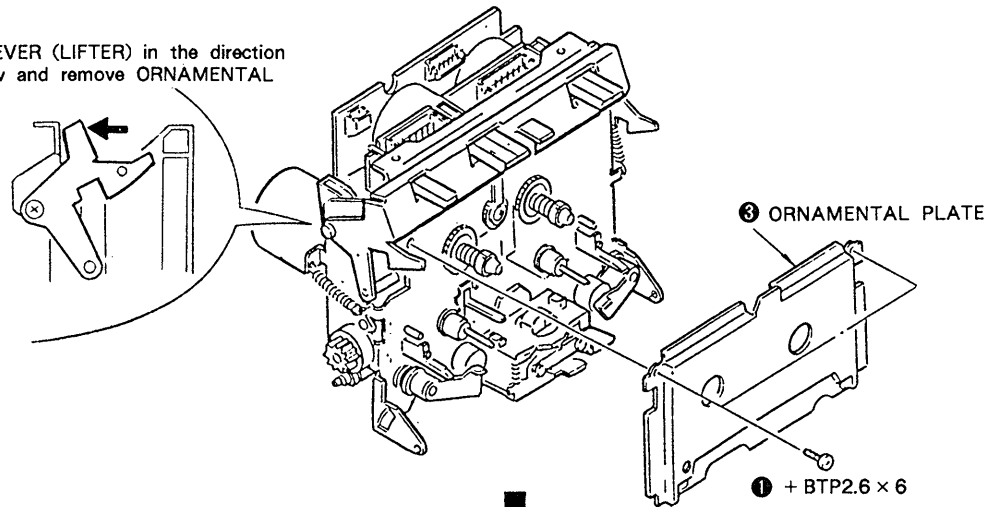

PINCH LEVER/HEAD

5 Removal of HEAD

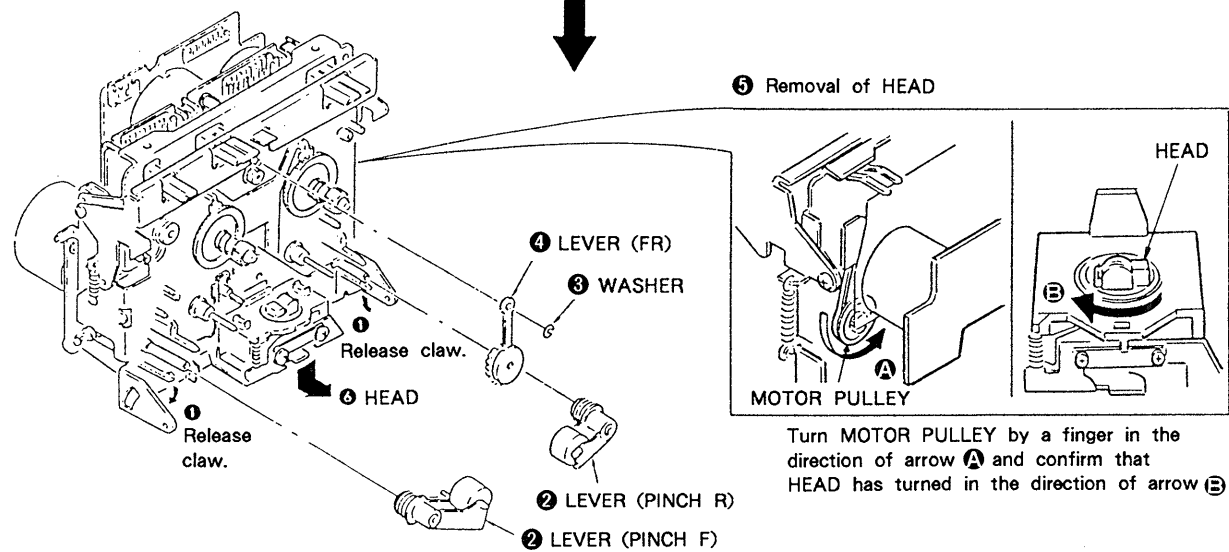

CAPSTAN MOTOR/FLYWHEEL

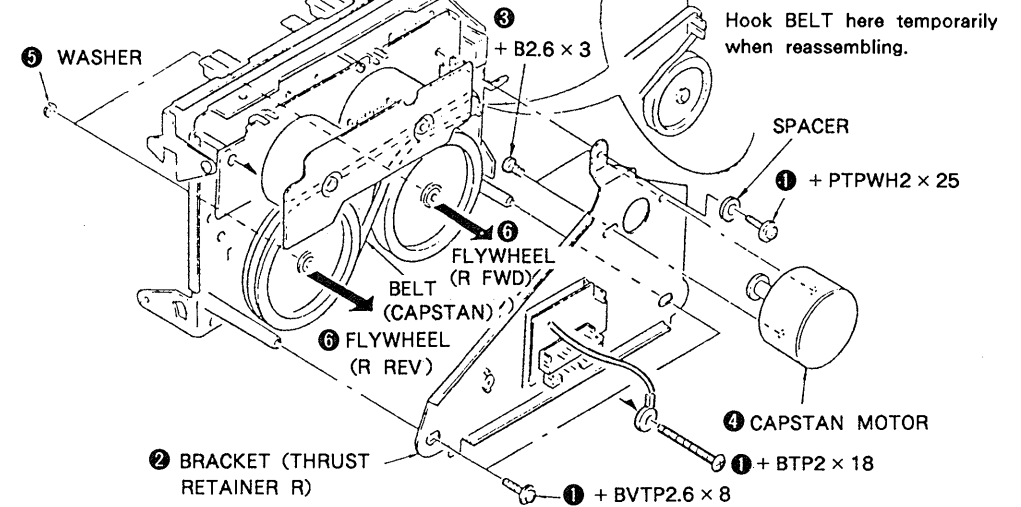

REEL and ASSIST MOTORS

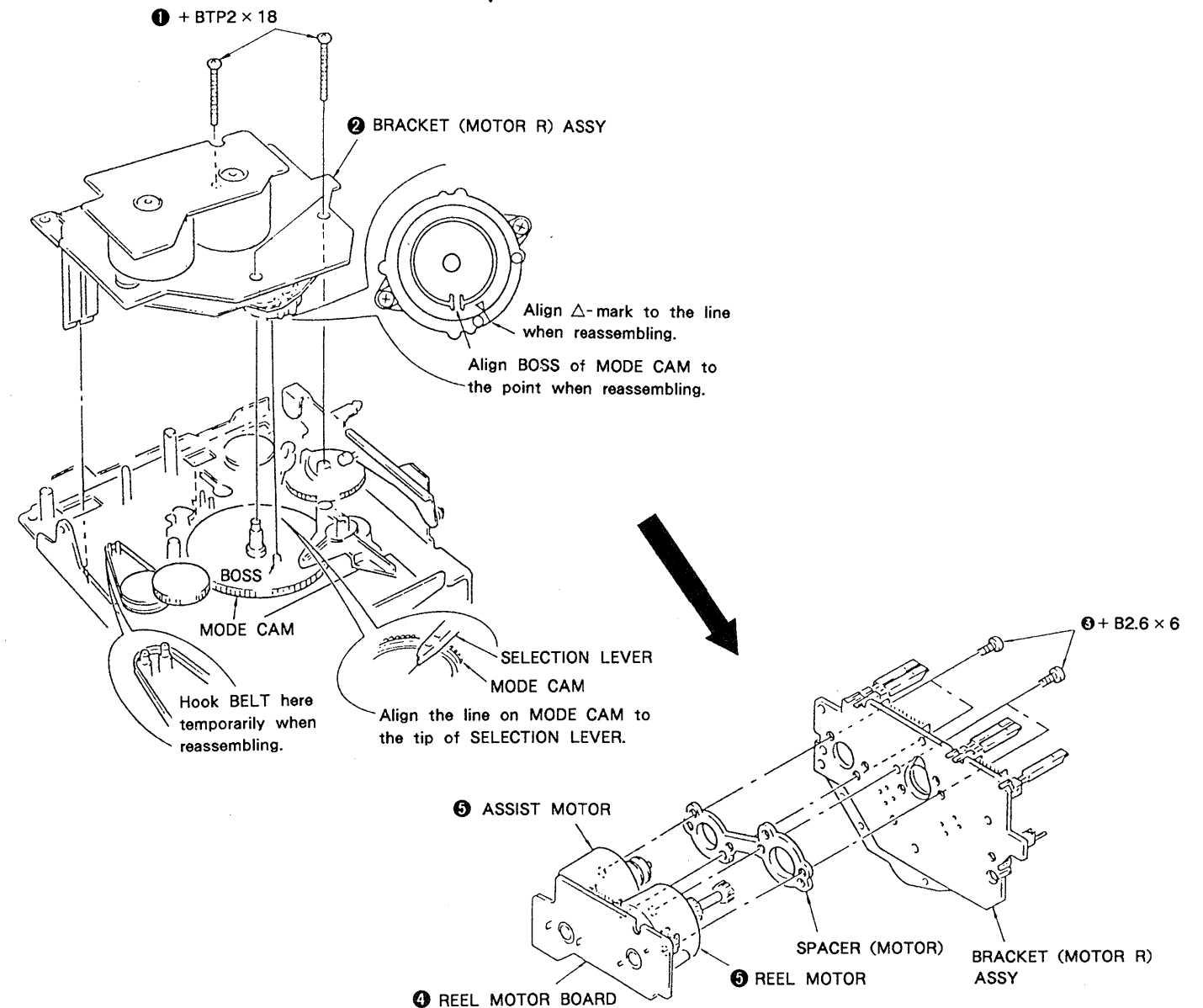

SECTION 3 ADJUSTMENTS

3-1. MECHANICAL ADJUSTMENTS

PRECAUTION

1. Clean the following parts with a denatured-alcohol-moistened swab :

record/playback head	pinch roller
erase head	rubber belts
capstan	idler
2. Demagnetize the record/playback head with a head demagnetizer.
3. Do not use a magnetized screwdriver for the adjustments.
4. After the adjustments, apply suitable locking compound to the parts adjusted.

TORQUE MEASUREMENT

Torque	Torque meter	Meter reading
FWD	CQ-102C	30 - 60g · cm (0.42 - 0.83oz · inch)
FWD Back tention	CQ-102C	1 - 5g · cm (0.014 - 0.069oz · inch)
REV	CQ-102RC	30 - 60g · cm (0.42 - 0.83oz · inch)
REV Back tention	CQ-102RC	1 - 5g · cm (0.014 - 0.069oz · inch)
FF, REW	CQ-201B	65 - 90 · cm (0.9 - 1.25oz · inch)

3-2. ELECTRICAL ADJUSTMENT

Note : The adjustment should be performed in the order given in the service manual. As a rule, adjustments about playback should be performed before those about recording. The adjustments should be performed for both L-CH and R-CH.

- Switches and controls should be set as follows unless otherwise specified.

DOLBY NR switch : OFF
DIRECTION switch : \rightleftarrows

- Standard Record :

Deliver the standard input signal level to the input jack and set the REC LEVEL control to obtain the standard output signal level.

—Record Mode—

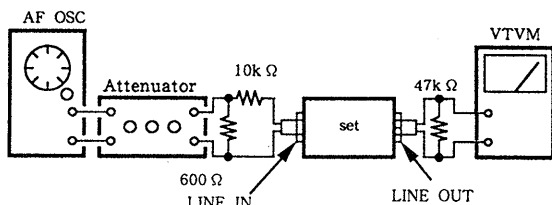

Standard Input Level

input terminal	LINE IN
source impedance	10k Ω
input level	0.25V (-10dB)

Standard Output Level

output terminal	LINE OUT
load impedance	47k Ω
output level	0.32V (-7dBs (m))

Test Tape

Type	Signal	Used for
P-4-A100	10kHz, -10dB	Azimuth Adjustment
P-4-L300	315Hz, 0dB	PB Level Adjustment
WS-48B	3kHz, 0dB	Tape Speed Adjustment

Test Mode

1. Put the set into the test mode by shorting test point TP801 (TEST) of the main board during the set is turned off.
2. Remove the short after the Electrical Adjustment is completed.

Record/Playback Head Azimuth Adjustment

Procedure :

1. Mode : FWD playback

Test tape
P-4-A100
(10kHz, -10dB)

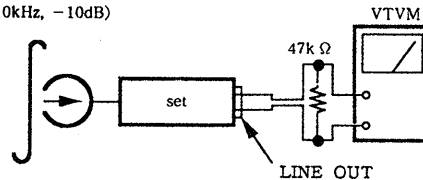

2. Turn the adjustment screw for the maximum output levels. If these levels do not match, turn the adjustment screw until both of output levels match together within 1dB.

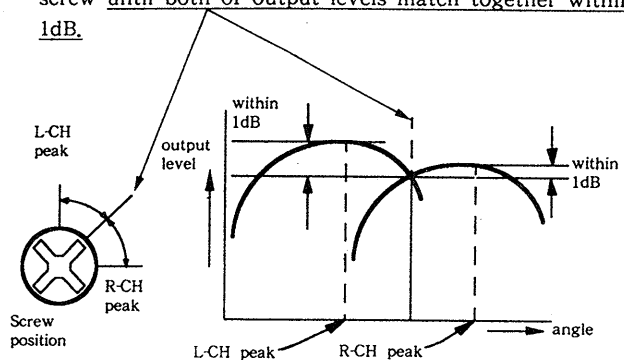

3. Phase Check
Mode : playback

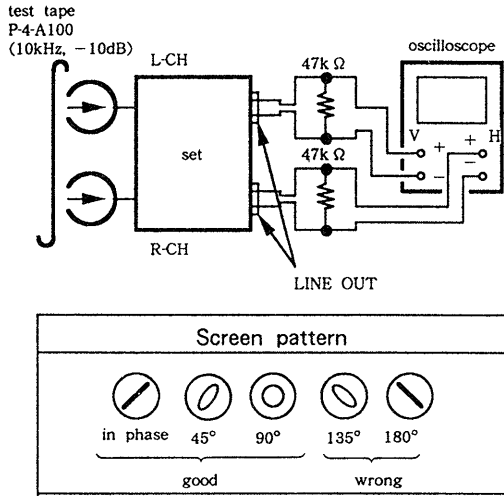

Adjustment Location :
motor rear side

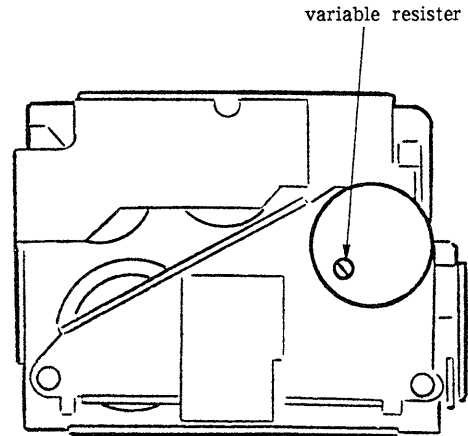

4. Set in the REV mode and repeat the step 1-3.
5. After the adjustment, lock the screws with locking compound.

Adjustment Location : Record/Playback head

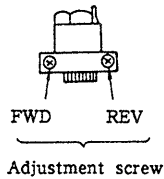

Tape Speed Adjustment

Setting :
test pin TP801 : short

Procedure :
Mode : playback

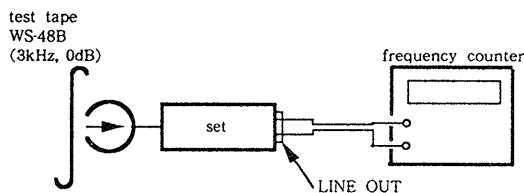

1. Set to FWD playback mode.
2. Adjust motor rear side (variable resistor) so that the frequency counter reading becomes $3,000 \pm 15\text{Hz}$.

Playback Level Adjustment

Procedure :
Mode : playback

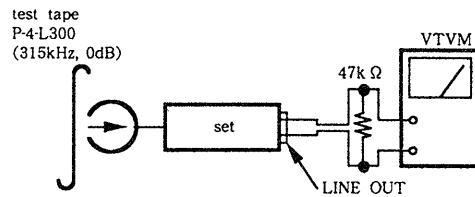

Adjust RV101 (L-ch) and RV201 (R-ch) so that the reading on VTVM meets the adjustment limits below.

Adjustment Limits :

LINE OUT level : $-7.7\text{dBs(m)} \pm 0.5\text{dB}(0.3\sim 0.34\text{V})$

Level difference between channels : less than 0.5dB

Check that the LINE OUT level does not change even if Playback and Stop operation is repeated several times.

Adjustment Location : Main board

Bias Current Adjustment

Procedure :

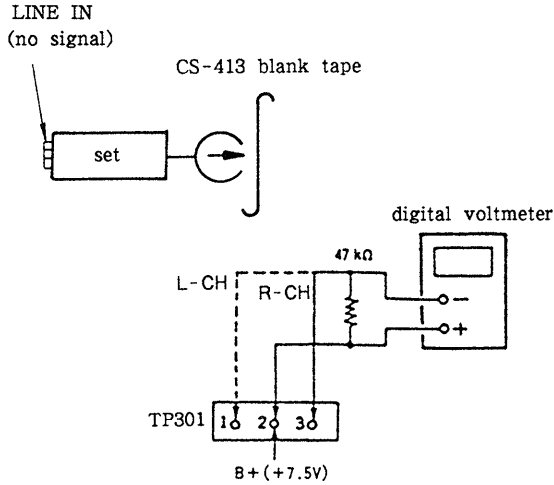

1. Set RV103 and RV203 to mechanical center and turn the set recording mode.
2. Connect digital voltmeter as shown by the following table.
3. Adjust the following transformers for the minimum readings on the digital voltmeter.

	Mesurement Point	Adjustment Part	Value
L-ch	① and ②, TP301	T101	not more than
R-ch	② and ③, TP301	T201	130mV

Adjustment Location : Main board

Record Bias Adjustment

Setting :

REC LEVEL control : Standard Record (See page 7.)
test pin TP801 : short

Procedure :

1. Mode : record

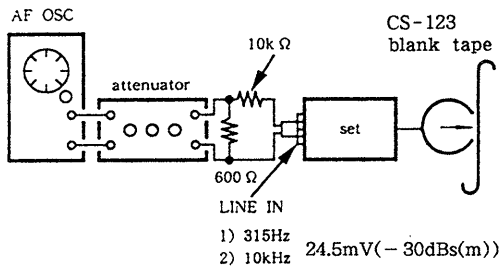

2. Mode : playback

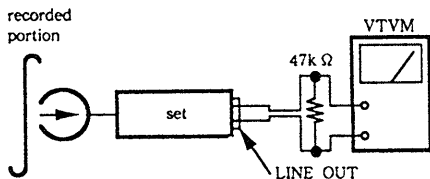

Playback the signal recorded in step 1.

Confirm that the 10kHz playback output is $0 \pm 0.5\text{dB}$ relative to the 315Hz output. If necessary, adjust RV103 (L-ch) and RV203 (R-ch) for repeat the steps given above.

Adjustment Location : Main board

Record Level Adjustment

Setting :

REC LEVEL control : Standard Record (See page 7.)
test pin TP801 : short

Procedure :

1. Mode : record

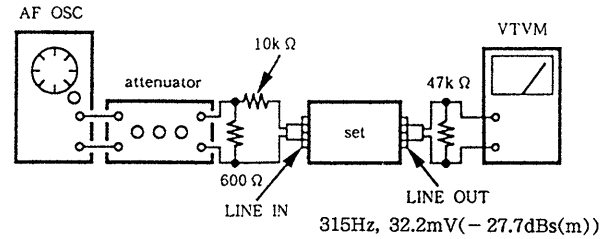

2. Mode : playback

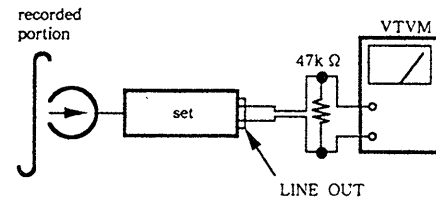

3. Playback the signal recorded in step1.

Confirm that the signal level is within the adjustment limits below. If necessary, adjust RV102 (L-ch) and RV202 (R-ch) repeat the step1-2.

Adjustment Limits : $-27.7\text{dBs(m)} \pm 0.5\text{dB}(30.4 \sim 34.2\text{mV})$

Adjustment Location : Main board

Quick Reverse Sensitivity Adjustment

Conditions :

DIRECTION MODE switch : \rightleftarrows

Adjustment procedure :

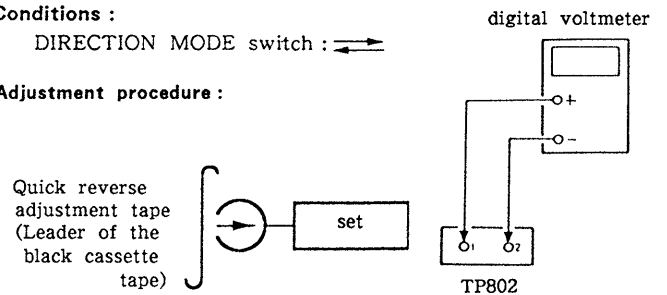

1. Connect the digital voltmeter to test point TP802.
2. Load quick reverse adjustment tape and play back the leading portion in FWD mode.
3. Adjust the RV801 for $4.5 \pm 0.5\text{V}$ reading on the digital voltmeter.
4. Play back quick reverse adjustment tape in FWD mode again.
5. Confirm that the reading on the digital voltmeter is "L" level at the magnetic portion of the tape.
6. Confirm that the tape stop around the tape end (border of the leading and the magnetic portions).

Adjustment Location : Main board

Adjustment Parts Location

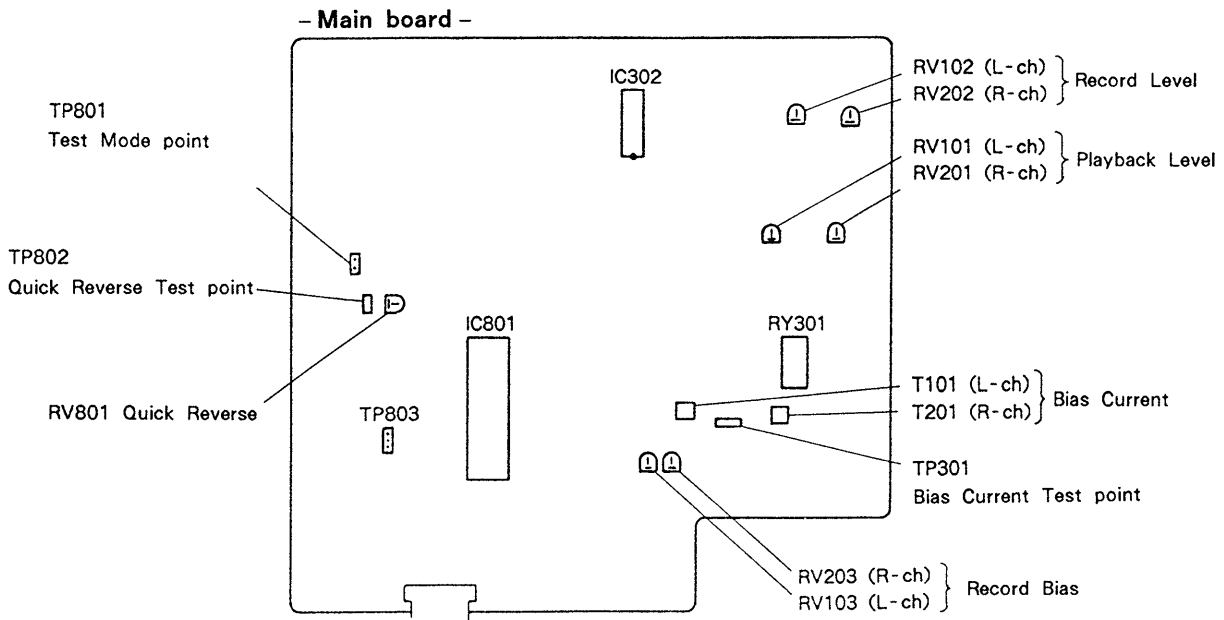

SECTION 4
DIAGRAMS

4-1. SEMICONDUCTOR LEAD LAYOUTS

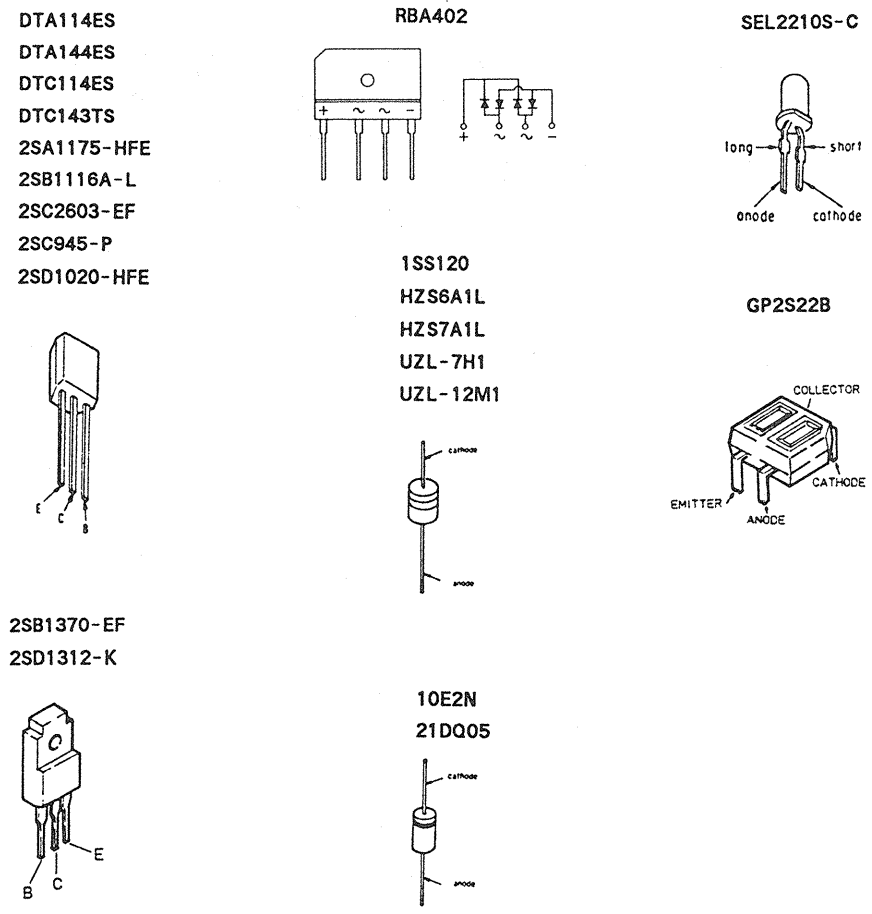

4-2. CIRCUIT BOARDS LOCATION

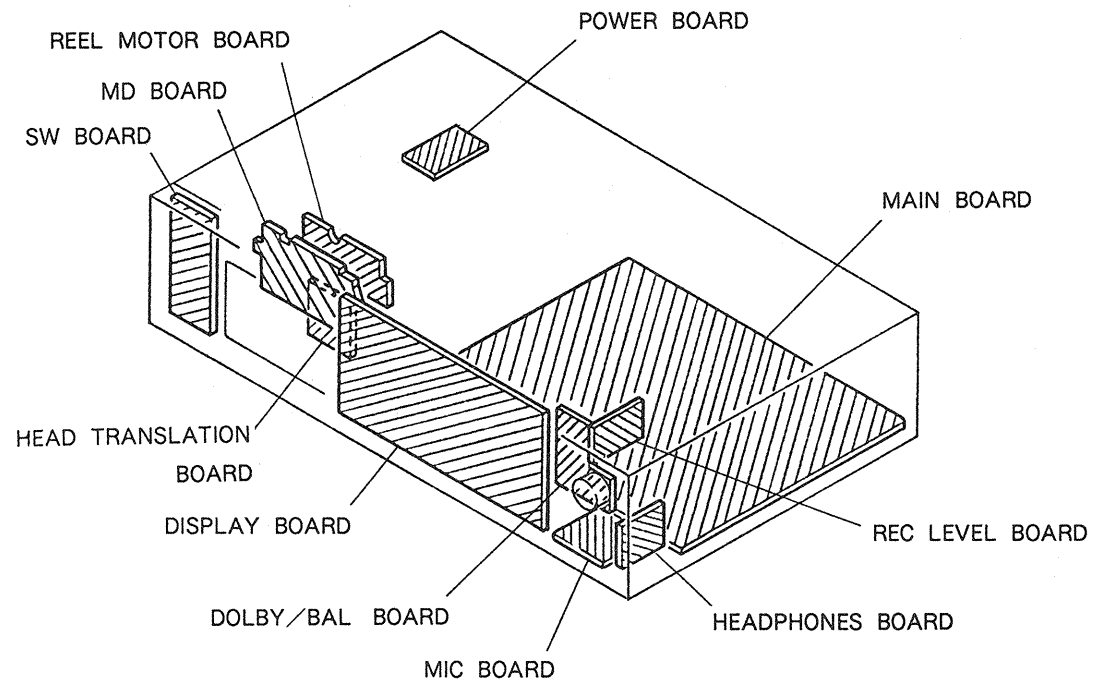

4-3. PRINTED WIRING BOARDS

4-3-1. FORMER TYPE (Main Board US model and Main Board No. 1-638-124-12 only.)

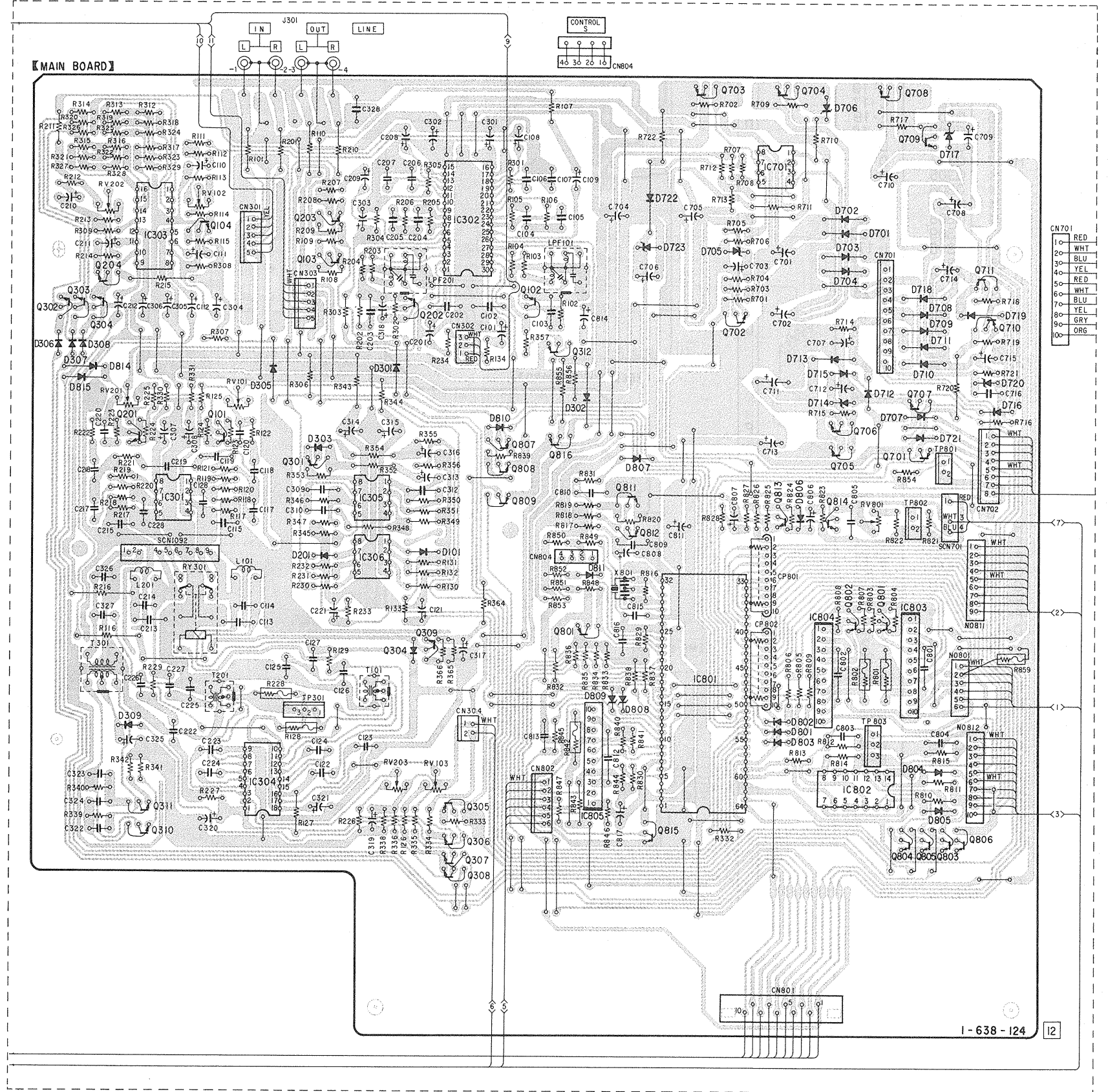

• Semiconductor Location

Ref. No.	Location	Ref. No.	Location
D101	F-20	Q102	C-21
D201	F-19	Q103	C-19
D301	D-20	Q104	C-18
D302	D-21	Q201	E-17
D303	E-19	Q202	D-20
D304	G-20	Q203	C-19
D305	D-18	Q204	C-17
D306	D-16	Q301	E-19
D307	D-16	Q302	D-16
D308	D-17	Q303	D-16
D309	H-17	Q304	D-17
D701	C-24	Q305	H-20
D702	C-24	Q306	I-20
D703	C-24	Q307	I-20
D704	C-24	Q308	I-20
D705	C-23	Q309	G-20
D706	B-24	Q310	I-17
D707	E-25	Q311	H-17
D712	D-24	Q312	D-21
D713	D-24	Q701	E-25
D714	D-24	Q702	D-23
D715	D-24	Q703	A-23
D716	D-25	Q704	A-23
D717	B-25	Q705	E-24
D718	C-25	Q706	E-24
D719	D-25	Q707	D-25
D720	D-25	Q708	A-24
D721	E-25	Q709	B-25
D722	B-22	Q710	D-25
D723	C-22	Q711	C-25
D724	D-25	Q801	G-24
D801	H-23	Q802	G-24
D802	H-23	Q803	I-25
D803	H-23	Q804	I-25
D804	H-25	Q805	I-25
D805	H-25	Q806	I-25
D806	F-24	Q807	E-21
D807	E-22	Q808	E-21
D808	G-22	Q809	E-21
D809	G-22	Q810	G-21
D810	E-21	Q811	E-22
D811	F-21	Q812	F-22
D814	D-17	Q813	F-23
D815	D-17	Q814	F-24
D901	G-9	Q815	I-22
D902	G-9	Q816	E-21
D903	I-7	Q901	H-9
D1051	F-4	Q902	H-9
		Q903	H-9
IC301	E-17	Q904	H-9
IC302	C-20	Q905	H-9
IC303	C-17	Q906	H-7
IC304	H-18		
IC305	F-19		
IC306	C-13		
IC601	C-13		
IC701	B-23		
IC801	G-23		
IC802	H-24		
IC803	G-25		
IC804	G-24		
IC805	H-22		
IC901	H-11		
IC902	H-7		
IC1001	H-2		
IC1002	H-4		
Q101	E-18		

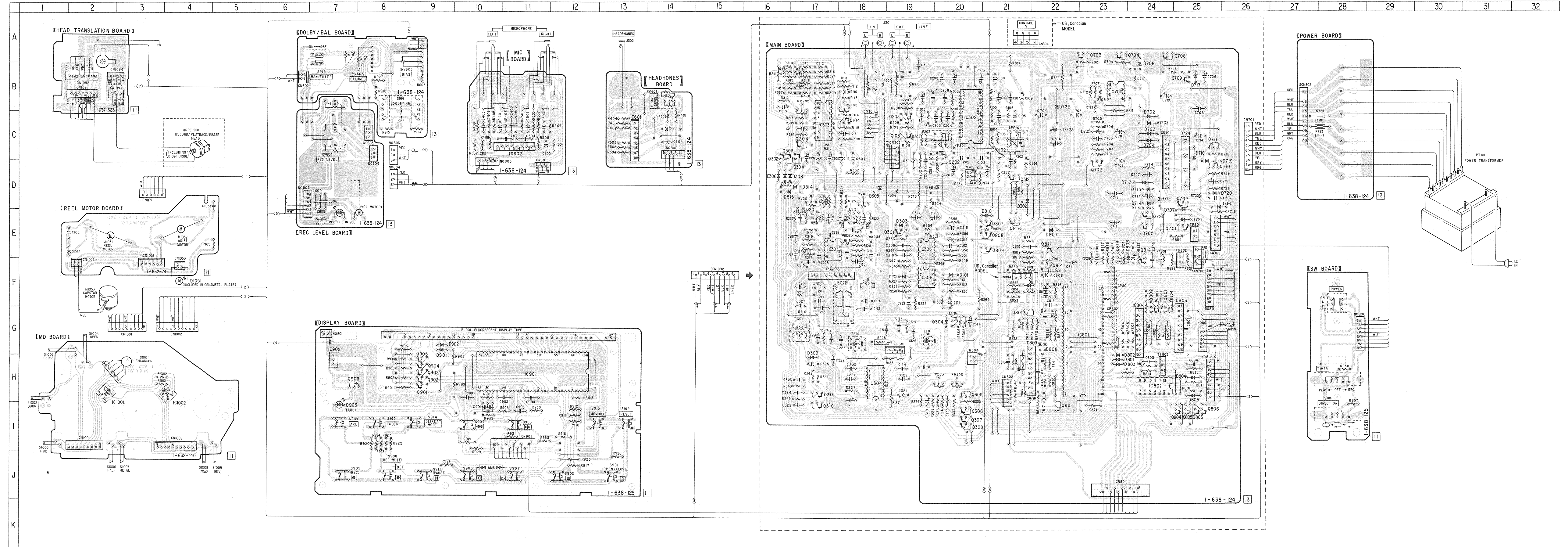

Note on Mounting Diagram:
 • ○ : parts extracted from the component side.
 • ⊗ : indicates side identified with part number.

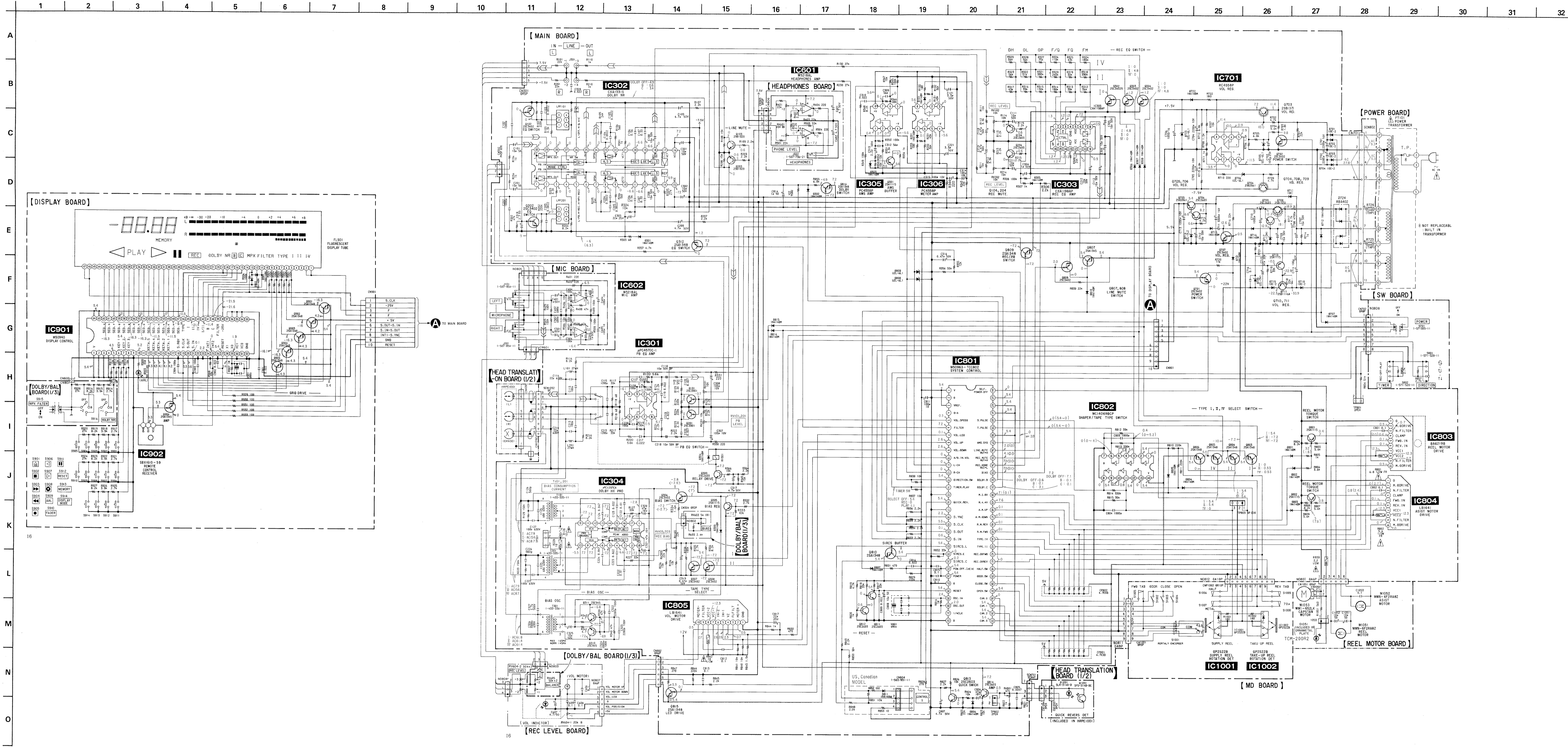

Note on Schematic Diagram:

- All capacitors are in μF unless otherwise noted, pF: μF 50WV or less are not indicated except for electrolytics and tantalums.
- All resistors are in Ω and $\frac{1}{2}\text{W}$ or less unless otherwise specified.
- f : fusible resistor.

Note: The components identified by mark Δ or dotted line with mark Δ are critical for safety. Replace only with part number specified.

- : B+ Line
- : B- Line
- : adjustment for repair.
- : Voltage and waveforms are dc with respect to ground under no-signal (detuned) conditions.
- no mark: STOP MODE I: NORMAL TAPE
- () : PLAY MODE II: CIO2 TAPE
- < > : REC MODE IV: METAL TAPE
- [] : DOLBY MODE
- B : DOLBY B MODE
- C : DOLBY C MODE
- : Voltages are taken with a VOM (impedance 10M Ω)
- Voltage variations may be noted due to normal production tolerances.
- : Signal path.
- : PB
- : REC

SECTION 5 EXPLODED VIEWS

NOTE :

- -XX, -X mean standardized parts, so they may have some differences from the original one.
- Color Indication of Appearance Parts
Example :
KNOB, BALANCE (WHITE)...(RED)
 ↑ ↑
 Parts color Cabinet's color

- Items marked "*" are not stocked since they are seldom required for routine service. Some delay should be anticipated when ordering these items.
- The mechanical parts with no reference number in the exploded views are not supplied.
- Hardware (# mark) list is given in the last of this parts list.

<p>The components identified by mark or dotted line with mark are critical for safety. Replace only with part number specified.</p>
<p>Les composants identifiés par une marque sont critiques pour la sécurité. Ne les remplacer que par une pièce portant le numéro spécifié.</p>

5-1. FRONT PANEL SECTION

- | |
|------------------------|
| ■ A : SW BOARD |
| ■ B : DISPLAY BOARD |
| ■ C : MIC BOARD |
| ■ D : DOLBY/BAL BOARD |
| ■ E : REC LEVEL BOARD |
| ■ F : HEADPHONES BOARD |

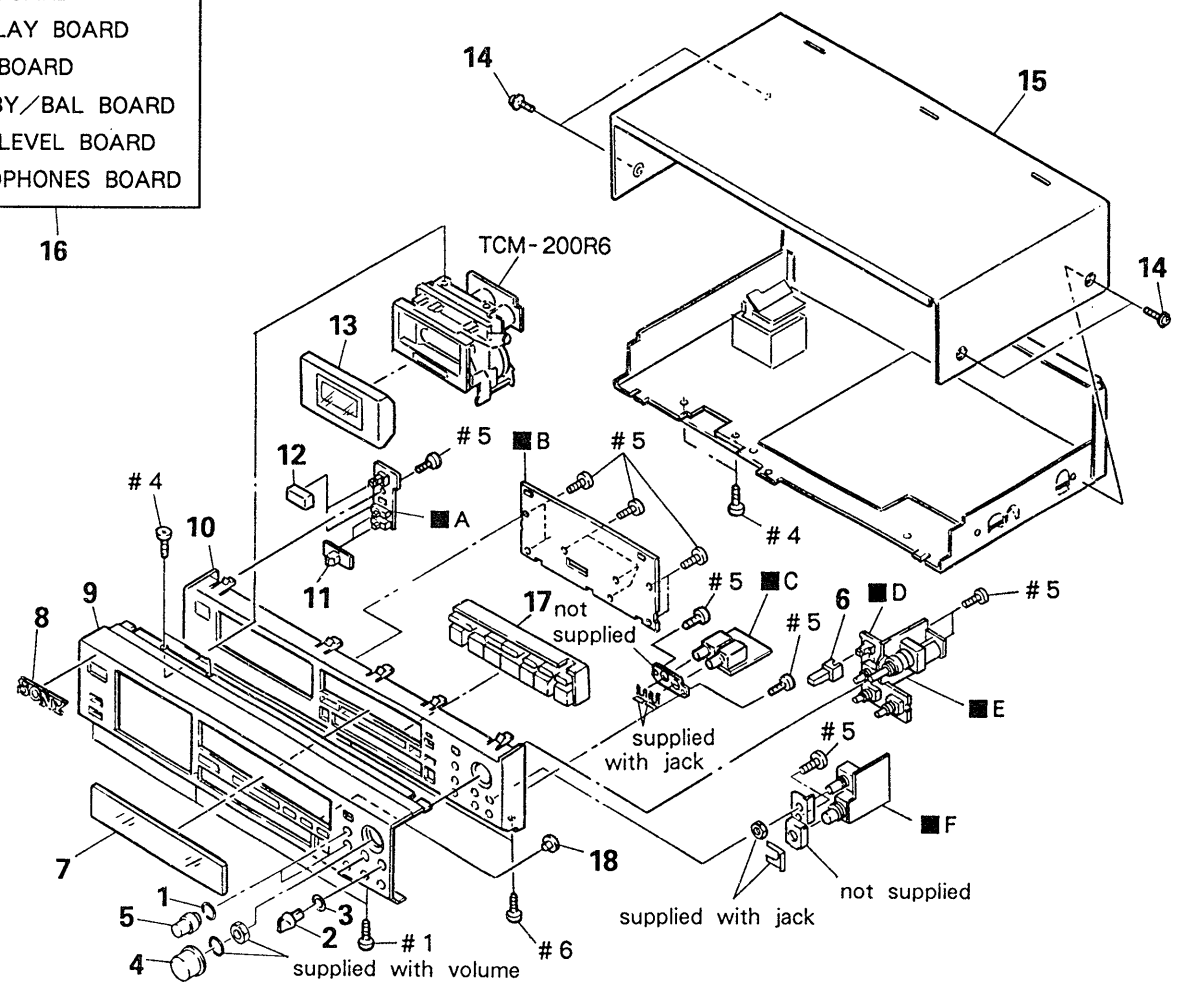

Ref. No.	Part No.	Description	Remark
1	3-356-957-01	SPRING	
2	3-350-495-01	KNOB (VOL)	
3	3-370-186-01	SPRING (SWPA), RING	
4	X-3362-823-1	KNOB (REC) ASSY	
5	3-367-431-01	KNOB (BAL)	
6	3-350-473-01	BUTTON	
7	3-367-430-01	WINDOW (METER) (US, Canadian)	
	3-367-433-11	WINDOW (METER) (AEP)	
8	4-908-848-01	EMBLEM, SONY	
9	3-367-439-12	PANEL, FRONT (US, Canadian)	
	3-367-439-22	PANEL, FRONT (AEP)	

Ref. No.	Part No.	Description	Remark
10	3-367-440-01	PANEL (BASE)	
11	4-931-421-11	KNOB (T & S)	
12	4-922-921-01	BUTTON (POWER)	
13	X-3362-822-1	LID (B) ASSY, CASSETTE (US, Canadian)	
	X-3362-821-1	LID(A) ASSY, CASSETTE (AEP)	
14	3-363-099-01	SCREW (CASE +3X8 TP2)	
15	3-332-578-61	CASE	
16	* A-2006-441-A	PANEL BOARD (US, Canadian)	
	* A-2006-440-A	PANEL BOARD (AEP)	
17	3-367-434-01	BUTTON (A)	
18	3-367-428-01	PLATE, INDICATION	

5-2. CHASSIS SECTION

▲ A : POWER BOARD

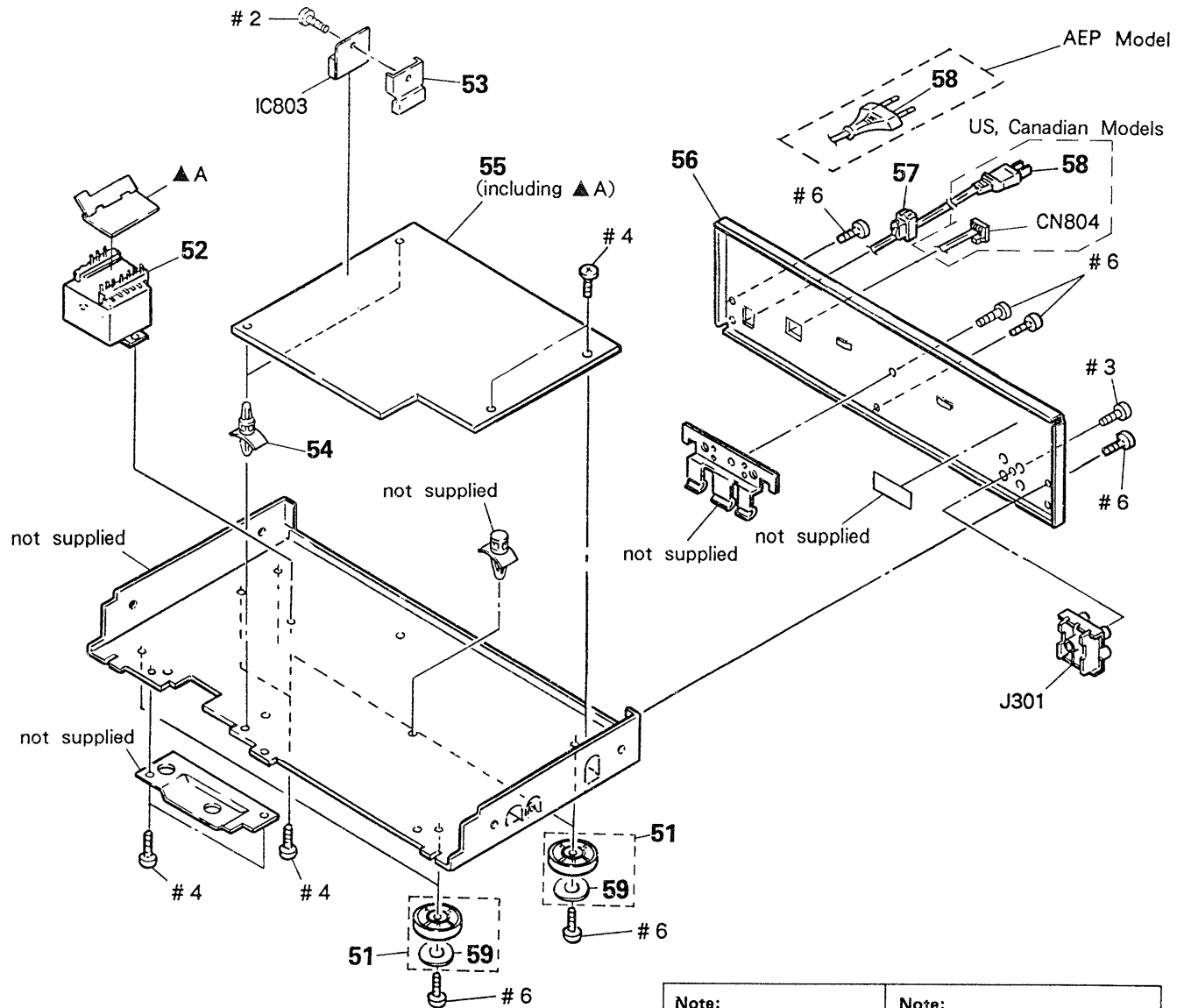

Note:
The components identified by mark ▲ or dotted line with mark ▲ are critical for safety. Replace only with part number specified.

Note:
Les composants identifiés par une marque ▲ sont critiques pour la sécurité. Ne les remplacer que par une pièce portant le numéro spécifié.

Ref. No.	Part No.	Description	Remark
51	X-3304-938-2	FOOT ASSY	
52	▲1-450-100-11	TRANSFORMER, POWER (US, Canadian)	
	▲1-450-399-11	TRANSFORMER, POWER (AEP)	
53	* 3-356-925-01	HEAT SINK	
54	* 3-346-265-11	HOLDER, PC BOARD	
55	* A-2006-438-A	MAIN BOARD (US, Canadian)	
	* A-2006-439-A	MAIN BOARD (AEP)	
56	* 3-366-791-11	PANEL, BACK (US, Canadian)	
	* 3-366-791-31	PANEL BACK (AEP)	

Ref. No.	Part No.	Description	Remark
57	* 3-703-571-11	BUSHING (S) (4516), CORD (US, Canadian)	
	* 3-703-244-00	BUSHING (2104), CORD (AEP)	
58	▲1-551-506-XX	CORD, POWER (US, Canadian)	
	▲1-555-795-00	CORD, POWER, EURO PLUG (AEP)	
59	4-923-836-11	CUSHION	
CN804	1-558-350-31	CORD (WITH CONNECTOR) (US, Canadian)	
IC803	8-759-973-95	IC BA6219B	
J301	1-573-070-11	JACK, PIN 4P (LINE) (US, Canadian)	
	1-565-258-11	JACK, PIN 4P (LINE) (AEP)	

5-3. MECHANISM SECTION (TCM-200R6)

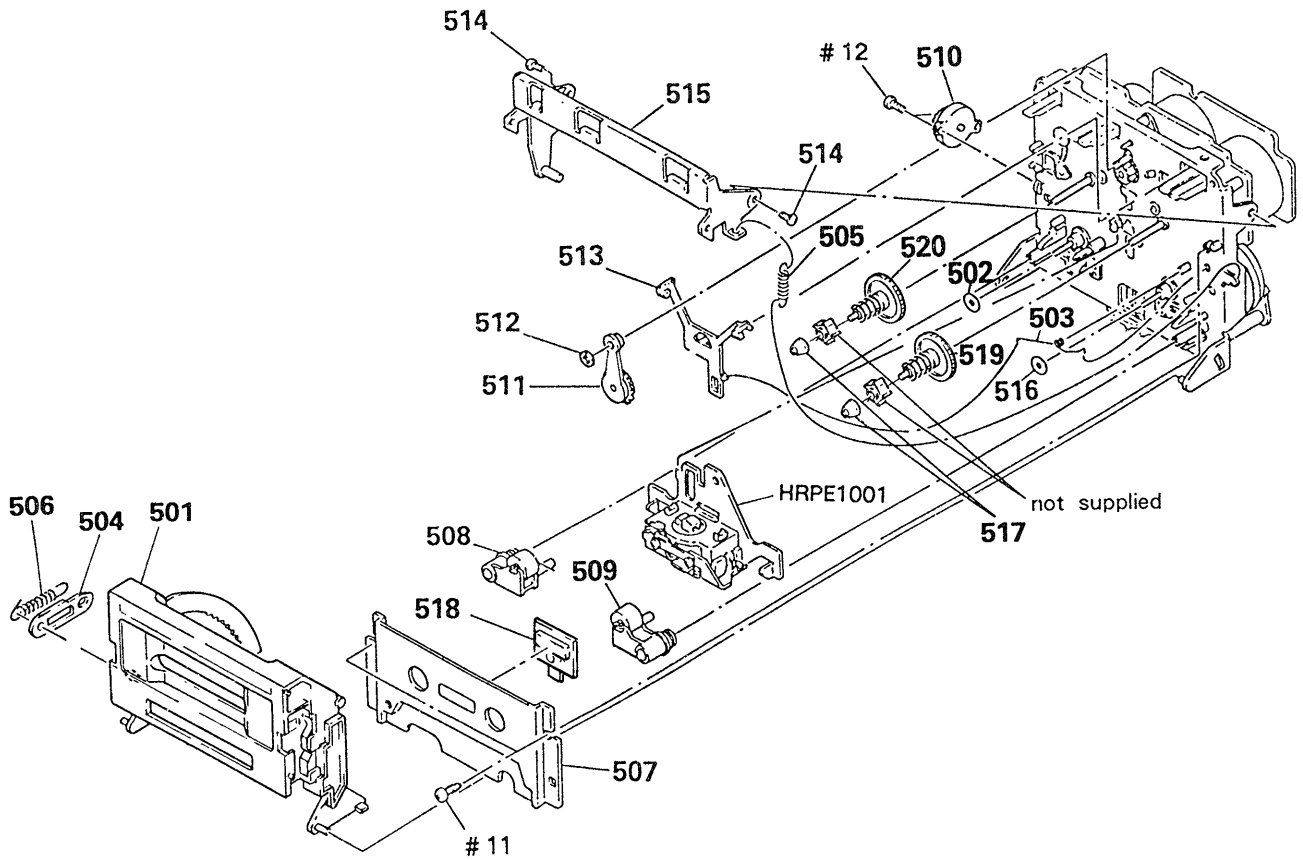

Ref. No.	Part No.	Description	Remark	Ref. No.	Part No.	Description	Remark
501	X-3362-814-1	HOLDER (CD) ASSY, CASSETTE		511	X-3356-641-1	LEVER (FR2) ASSY	
502	3-356-714-01	WASHER		512	3-669-465-11	WASHER (1.5), STOPPER	
503	3-356-619-01	SPRING (B), TORSION		513	3-356-614-01	SLIDER (BRAKE)	
504	* 3-356-717-01	LEVER (JOINT)		514	3-356-601-11	SCREW, STEP	
505	3-356-625-01	SPRING, TENSION		515	* X-3356-608-1	LEVER (LIFTER) ASSY	
506	3-356-626-01	SPRING, TENSION		516	3-356-713-01	WASHER	
507	X-3356-613-1	PLATE ASSY, ORNAMENTAL		517	3-362-308-01	CAP (REEL)	
508	X-3343-456-1	LEVER (PINCH R) ASSY		518	8-719-980-85	DIODE SLF-325C	
509	X-3343-455-1	LEVER (PINCH F) ASSY		519	X-3356-627-1	GEAR (T) ASSY	
510	3-712-786-01	DAMPER, OIL		520	X-3356-628-1	GEAR (S) ASSY	
				HRPE1001	A-2003-722-A	SLIDER (R4) COMPLETE ASSY	

5-4. MECHANISM SECTION (TCM-200R6)

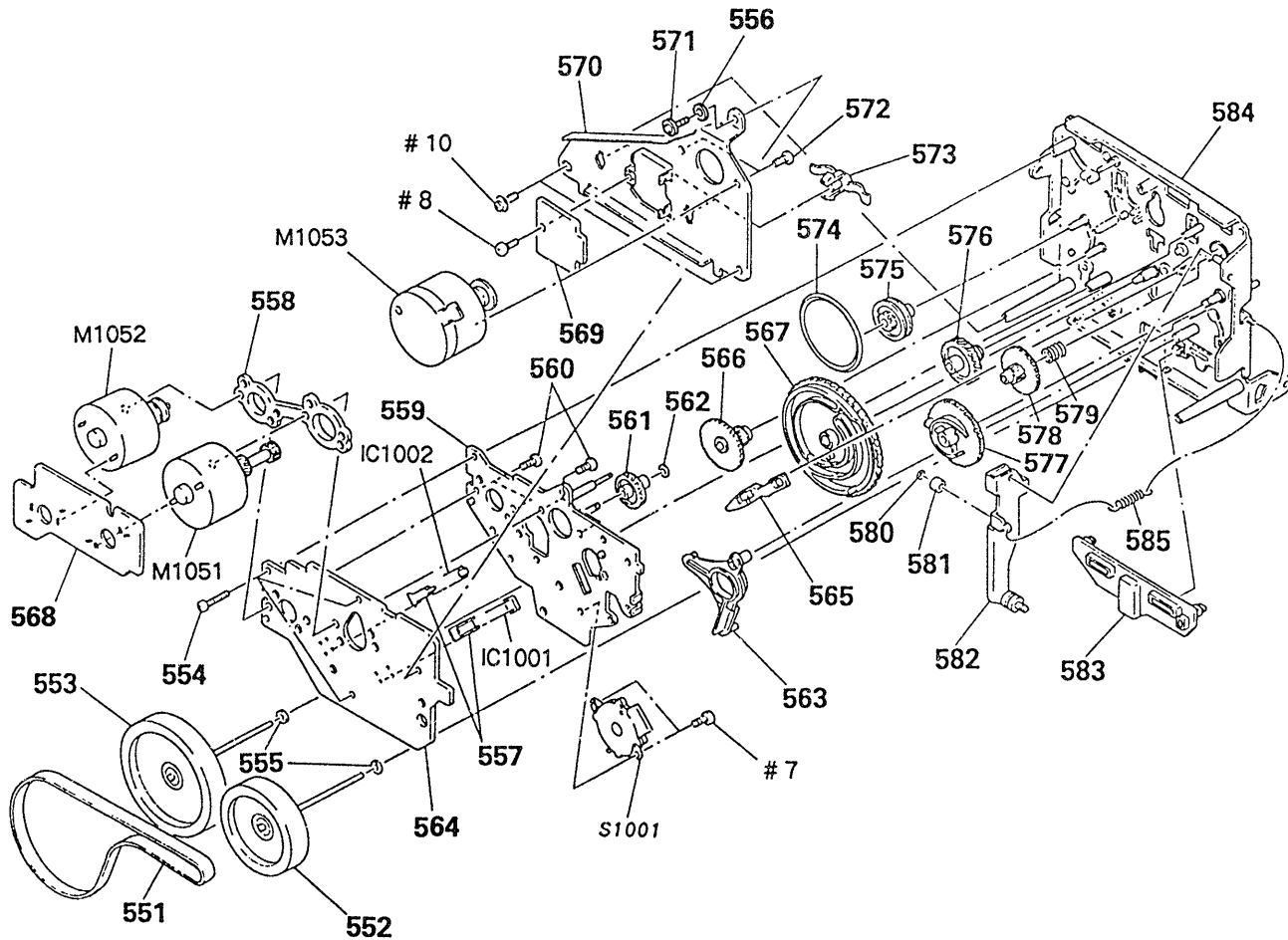

Ref. No.	Part No.	Description	Remark	Ref. No.	Part No.	Description	Remark
551	3-356-730-01	BELT (CAPSTAN R2)		571	3-356-707-01	SCREW (+PTPWH 2X25)	
552	X-3356-642-1	FLYWHEEL (R FWD) ASSY		572	4-885-599-00	SCREW, FITTING, REINFORCEMENT	
553	X-3356-643-1	FLYWHEEL (R REV) ASSY		573	3-575-321-00	RETAINER, THRUST, CAPSTAN	
554	3-355-801-01	SCREW (BTP 2X18)		574	3-356-603-01	BELT (MODE)	
555	3-356-705-01	WASHER (CAPSTAN)		575	3-356-607-01	PULLEY (MODE)	
556	* 3-356-718-01	SPACER (THRUST RETAINER R)		576	3-356-703-01	GEAR (COMMUNICATION C)	
557	3-356-631-01	HOLDER (SENSOR)		577	3-356-616-01	GEAR (LOADING CAM)	
558	* 3-356-628-01	SPACER (MOTOR)		578	3-356-609-01	GEAR (LOADING)	
559	* X-3356-602-4	BRACKET (MOTOR R) ASSY		579	3-356-605-01	SPRING, COMPRESSION	
560	3-363-804-01	SCREW (+P 2. 6X6. 5)		580	3-558-708-11	WASHER, STOPPER	
561	3-356-702-01	GEAR (COMMUNICATION B)		581	3-356-630-01	ROLLER (LOADING)	
562	3-669-465-00	WASHER (1.5), STOPPER		582	* X-3356-606-1	LEVER (LOADING) ASSY	
563	3-356-613-01	LEVER (MODE)		583	3-356-612-01	SLIDER (REVERSE)	
564	* 1-632-740-11	MD BOARD		584	X-3356-634-1	CHASSIS (R2) COMPLETE ASSY, MECH	
565	3-356-617-01	LEVER (SELECTION)		585	3-356-624-01	SPRING, TENSION	
566	3-356-606-01	GEAR (MODE)		IC1001	8-749-920-97	IC PHOTO REFLECTOR GP2S22B	
567	3-356-615-01	GEAR (MODE CAM RR)		IC1002	8-749-920-97	IC PHOTO REFLECTOR GP2S22B	
568	* 1-632-741-11	REAL MOTOR BOARD		M1051	X-3356-638-1	MOTOR (REEL R) ASSY	
569	* 1-634-323-11	TRANSLATION BOARD		M1052	X-3356-604-1	MOTOR (ASSIST) ASSY	
570	* 3-356-629-01	BRACKET (THRUST RETAINER R)		M1053	X-3356-646-1	MOTOR (CAPSTAN V1) ASSY	
				S1001	1-466-525-11	ENCODER, ROTARY	

SECTION 5 ELECTRICAL PARTS LIST

TRANSLATION

MD MAIN

NOTE :

The components identified by mark or dotted line with mark are critical for safety. Replace only with part number specified.

Les composants identifiés par une marque sont critiques pour la sécurité. Ne les remplacer que par une pièce portant le numéro spécifié.

When indicating parts by reference number, please include the board name.

- Due to standardization, replacements in the parts list may be different from the parts specified in the diagrams or the components used on the set.
- -XX, -X mean standardized parts, so they may have some difference from the original one.
- RESISTORS
All resistors are in ohms.
METAL : metal-film resistor
METAL OXIDE: Metal Oxide-film resistor
F : nonflammable
- Items marked "*" are not stocked since they are seldom required for routine service. Some delay should be anticipated when ordering these items.
- SEMICONDUCTORS
In each case, u : μ , for example :
uA... : μ A..., uPA..., μ PA...,
uPB..., μ PB..., uPC..., μ PC...,
uPD..., μ PD...
- CAPACITORS :
uF : μ F
- COILS
uH : μ H

Ref. No.	Part No.	Description	Remark	Ref. No.	Part No.	Description	Remark
	* 1-634-323-11	TRANSLATION BOARD *****				< CAPACITOR >	
		< CONNECTOR >		C101	1-124-907-11	ELECT	10uF 20% 50V
CN1091	* 1-564-709-11	PIN, CONNECTOR (SMALL TYPE) 7P		C102	1-162-294-31	CERAMIC	0.001uF 10% 50V
CN1092	* 1-564-509-11	PLUG, CONNECTOR 6P		C103	1-161-375-00	CERAMIC	0.0022uF 20% 50V
CN1093	* 1-564-705-11	PIN, CONNECTOR (SMALL TYPE) 3P		C104	1-130-475-00	MYLAR	0.0022uF 5% 50V
CN1094	* 1-564-506-11	PLUG, CONNECTOR 3P		C105	1-130-475-00	MYLAR	0.0022uF 5% 50V

	* 1-632-740-11	MD BOARD *****		C106	1-136-174-00	FILM	0.56uF 5% 50V
	3-356-631-01	HOLDER (SENSOR) < CONNECTOR >		C107	1-136-171-00	FILM	0.33uF 5% 50V
CN1001	1-506-615-11	PIN, CONNECTOR 9P		C108	1-124-907-11	ELECT	10uF 20% 50V
CN1002	* 1-564-502-11	PIN, CONNECTOR 10P < IC >		C109	1-124-927-11	ELECT	4.7uF 20% 100V
IC1001	8-749-920-97	IC PHOTO REFLECTOR GP2S22B		C110	1-124-902-00	ELECT	0.47uF 20% 50V
IC1002	8-749-920-97	IC PHOTO REFLECTOR GP2S22B < RESISTOR >		C111	1-124-907-11	ELECT	10uF 20% 50V
R1001	1-249-408-11	CARBON 180 5% 1/4W		C112	1-124-907-11	ELECT	10uF 20% 50V
R1002	1-249-408-11	CARBON 180 5% 1/4W		C113	1-162-285-31	CERAMIC	180PF 10% 50V
		< SWITCH >		C114	1-136-935-11	FILM	22PF 5% 630V
S1001	1-466-237-11	ENCODER, ROTARY		C115	1-164-736-31	CERAMIC	0.0012uF 10% 50V
S1002	1-570-953-11	SWITCH, PUSH (1 KEY)		C117	1-136-157-00	FILM	0.022uF 5% 50V
S1003	1-571-958-11	SWITCH, PUSH (1 KEY)		C118	1-124-657-00	ELECT	10uF 20% 50V
S1004	1-572-126-11	SWITCH, PUSH (1 KEY)		C119	1-161-494-00	CERAMIC	0.022uF 25V
S1005	1-572-125-11	SWITCH, LEAF		C120	1-136-158-00	FILM	0.027uF 5% 50V
S1006	1-572-202-11	SWITCH, LEAF		C121	1-123-382-00	ELECT	3.3uF 20% 100V
S1007	1-572-125-11	SWITCH, LEAF		C122	1-136-153-00	FILM	0.01uF 5% 50V
S1008	1-572-125-11	SWITCH, LEAF		C123	1-136-157-00	FILM	0.022uF 5% 50V
S1009	1-572-125-11	SWITCH, LEAF < CONNECTOR >		C124	1-136-161-00	FILM	0.047uF 5% 50V
TB1001	* 1-569-066-11	PIN, CONNECTOR 5P		C125	1-136-272-00	FILM	68PF 5% 630V

	* A-2006-438-A	MAIN BOARD (including) *****		C126	1-130-468-00	MYLAR	560PF 5% 50V
	* 3-356-925-01	HEAT SINK		C127	1-136-433-11	FILM	100PF 5% 630V
	7-682-547-04	SCREW +BVT 3X6 (S)		C128	1-162-282-31	CERAMIC	100PF 10% 50V
				C201	1-124-907-11	ELECT	10uF 20% 50V
				C202	1-162-294-31	CERAMIC	0.001uF 10% 50V
				C203	1-161-375-00	CERAMIC	0.0022uF 20% 50V
				C204	1-130-475-00	MYLAR	0.0022uF 5% 50V
				C205	1-130-475-00	MYLAR	0.0022uF 5% 50V
				C206	1-136-174-00	FILM	0.56uF 5% 50V
				C207	1-136-171-00	FILM	0.33uF 5% 50V
				C208	1-124-907-11	ELECT	10uF 20% 50V
				C209	1-124-927-11	ELECT	4.7uF 20% 100V
				C210	1-124-902-00	ELECT	0.47uF 20% 50V
				C211	1-124-907-11	ELECT	10uF 20% 50V
				C212	1-124-907-11	ELECT	10uF 20% 50V
				C213	1-162-285-31	CERAMIC	180PF 10% 50V
				C214	1-136-935-11	FILM	22PF 5% 630V
				C215	1-164-736-31	CERAMIC	0.0012uF 10% 50V
				C217	1-136-157-00	FILM	0.022uF 5% 50V
				C218	1-124-657-00	ELECT	10uF 20% 50V
				C219	1-161-494-00	CERAMIC	0.022uF 25V

MAIN

Ref. No.	Part No.	Description	Remark			Ref. No.	Part No.	Description	Remark		
C220	1-136-158-00	FILM	0.027uF	5%	50V	C709	1-124-907-11	ELECT	10uF	20%	50V
C221	1-123-382-00	ELECT	3.3uF	20%	100V	C710	1-124-360-00	ELECT	1000uF	20%	16V
C222	1-136-153-00	FILM	0.01uF	5%	50V	C711	1-124-887-00	ELECT	330uF	20%	16V
C223	1-136-157-00	FILM	0.022uF	5%	50V	C712	1-124-907-11	ELECT	10uF	20%	50V
C224	1-136-161-00	FILM	0.047uF	5%	50V	C713	1-124-473-11	ELECT	1000uF	20%	10V
C225	1-136-272-00	FILM	68PF	5%	630V	C714	1-124-122-11	ELECT	100uF	20%	50V
C226	1-130-468-00	MYLAR	560PF	5%	50V	C715	1-124-910-11	ELECT	47uF	20%	50V
C227	1-136-433-11	FILM	100PF	5%	630V	C716	1-164-159-11	CERAMIC	0.1uF		50V
C228	1-162-282-31	CERAMIC	100PF	10%	50V	C801	1-164-159-11	CERAMIC	0.1uF		50V
C301	1-124-907-11	ELECT	10uF	20%	50V	C802	1-164-159-11	CERAMIC	0.1uF		50V
C302	1-124-907-11	ELECT	10uF	20%	50V	C803	1-162-294-31	CERAMIC	0.001uF	10%	50V
C303	1-126-233-11	ELECT	22uF	20%	50V	C804	1-162-294-31	CERAMIC	0.001uF	10%	50V
C304	1-124-903-11	ELECT	1uF	20%	50V	C805	1-161-377-00	CERAMIC	0.0047uF	30%	16V
C305	1-124-907-11	ELECT	10uF	20%	50V	C806	1-124-477-11	ELECT	47uF	20%	25V
C306	1-124-907-11	ELECT	10uF	20%	50V	C807	1-124-927-11	ELECT	4.7uF	20%	100V
C307	1-124-443-00	ELECT	100uF	20%	10V	C808	1-124-907-11	ELECT	10uF	20%	50V
C308	1-124-443-00	ELECT	100uF	20%	10V	C809	1-161-494-00	CERAMIC	0.022uF		25V
C309	1-162-217-31	CERAMIC	56PF	5%	50V	C810	1-164-159-11	CERAMIC	0.1uF		50V
C310	1-161-494-00	CERAMIC	0.022uF		25V	C811	1-124-443-00	ELECT	100uF	20%	10V
C312	1-162-217-31	CERAMIC	56PF	5%	50V	C812	1-164-159-11	CERAMIC	0.1uF		50V
C313	1-124-925-11	ELECT	2.2uF	20%	100V	C813	1-164-159-11	CERAMIC	0.1uF		50V
C314	1-124-443-00	ELECT	100uF	20%	10V	C814	1-124-903-11	ELECT	1uF	20%	50V
C315	1-124-443-00	ELECT	100uF	20%	10V	C815	1-164-159-11	CERAMIC	0.1uF		50V
C316	1-124-902-00	ELECT	0.47uF	20%	50V	C816	1-161-494-00	CERAMIC	0.022uF		25V
C317	1-124-927-11	ELECT	4.7uF	20%	100V	C817	1-126-233-11	ELECT	22uF	20%	50V
C318	1-124-925-11	ELECT	2.2uF	20%	100V			< CONNECTOR >			
C319	1-124-902-00	ELECT	0.47uF	20%	50V	CN301	* 1-564-339-61	PIN, CONNECTOR	5P		
C320	1-124-477-11	ELECT	47uF	20%	25V	CN302	* 1-564-705-11	PIN, CONNECTOR (SMALL TYPE)	3P		
C321	1-124-477-11	ELECT	47uF	20%	25V	CN303	* 1-564-339-00	PIN, CONNECTOR	5P		
C322	1-136-230-00	FILM	0.0022uF	5%	100V	CN304	* 1-564-336-00	PIN, CONNECTOR	2P		
C323	1-136-230-00	FILM	0.0022uF	5%	100V	CN601	* 1-564-705-11	PIN, CONNECTOR (SMALL TYPE)	3P		
C324	1-130-856-00	FILM	0.0068uF	5%	100V	CN602	* 1-564-336-00	PIN, CONNECTOR	2P		
C325	1-124-907-11	ELECT	10uF	20%	50V	CN701	* 1-564-513-11	PLUG, CONNECTOR	10P		
C326	1-136-558-11	FILM	0.0039uF	5%	630V	CN702	* 1-564-342-11	PIN, CONNECTOR	8P		
C327	1-107-046-00	MICA	4.7PF		500V	CN801	* 1-580-784-11	CONNECTOR, BOARD TO BOARD			
C328	1-161-494-00	CERAMIC	0.022uF		25V	CN802	* 1-564-340-00	PIN, CONNECTOR	6P		
C401	1-124-903-11	ELECT	1uF	20%	50V	CN804	1-558-350-31	CORD (WITH CONNECTOR) (US, Canadian)			
C402	1-162-292-31	CERAMIC	680PF	10%	50V			< COMPOSITION CIRCUIT BLOCK >			
C403	1-124-903-11	ELECT	1uF	20%	50V	CP801	1-233-204-11	COMPOSITION CIRCUIT BLOCK			
C404	1-162-282-31	CERAMIC	100PF	10%	50V	CP802	1-233-204-11	COMPOSITION CIRCUIT BLOCK			
C501	1-124-903-11	ELECT	1uF	20%	50V			< DIODE >			
C502	1-162-292-31	CERAMIC	680PF	10%	50V	D101	8-719-912-20	DIODE	1SS120		
C503	1-124-903-11	ELECT	1uF	20%	50V	D201	8-719-912-20	DIODE	1SS120		
C504	1-162-282-31	CERAMIC	100PF	10%	50V	D301	8-719-912-20	DIODE	1SS120		
C601	1-124-927-11	ELECT	4.7uF	20%	100V	D302	8-719-912-20	DIODE	1SS120		
C602	1-124-927-11	ELECT	4.7uF	20%	100V	D303	8-719-912-20	DIODE	1SS120		
C604	1-124-443-00	ELECT	100uF	20%	10V	D304	8-719-912-20	DIODE	1SS120		
C605	1-124-443-00	ELECT	100uF	20%	10V	D305	8-719-912-20	DIODE	1SS120		
C606	1-164-159-11	CERAMIC	0.1uF		50V	D306	8-719-912-20	DIODE	1SS120		
C607	1-124-927-11	ELECT	4.7uF	20%	100V	D307	8-719-912-20	DIODE	1SS120		
C608	1-164-159-11	CERAMIC	0.1uF		50V	D308	8-719-912-20	DIODE	1SS120		
C609	1-164-159-11	CERAMIC	0.1uF		50V	D309	8-719-912-20	DIODE	1SS120		
C701	1-124-556-11	ELECT	2200uF	20%	16V	D701	8-719-200-77	DIODE	10E2N		
C702	1-124-556-11	ELECT	2200uF	20%	16V	D702	8-719-200-77	DIODE	10E2N		
C703	1-124-478-11	ELECT	100uF	20%	25V	D703	8-719-200-77	DIODE	10E2N		
C704	1-124-893-11	ELECT	2200uF	20%	10V	D704	8-719-200-77	DIODE	10E2N		
C705	1-124-893-11	ELECT	2200uF	20%	10V						
C706	1-124-360-00	ELECT	1000uF	20%	16V						
C707	1-124-907-11	ELECT	10uF	20%	50V						
C708	1-124-564-11	ELECT	4700uF	20%	25V						

MAIN

Ref. No.	Part No.	Description	Remark	Ref. No.	Part No.	Description	Remark
D705	8-719-933-33	DIODE HZS6A1L				< COIL >	
D706	8-719-933-33	DIODE HZS6A1L		L101	1-410-780-11	INDUCTOR 27mH	
D707	8-719-912-20	DIODE 1SS120		L201	1-410-780-11	INDUCTOR 27mH	
D712	8-719-912-20	DIODE 1SS120				< FILTER >	
D713	8-719-200-31	DIODE 21DQ05					
D714	8-719-933-43	DIODE HZS7A1L		LPF101	1-236-475-11	FILTER, LOW PASS	
D715	8-719-912-20	DIODE 1SS120		LPF201	1-236-475-11	FILTER, LOW PASS	
D716	8-719-912-20	DIODE 1SS120				< TRANSISTOR >	
D717	8-719-001-70	DIODE UZL-12M1		Q101	8-729-900-74	TRANSISTOR DTC143TS	
D718	8-719-200-77	DIODE 10E2N		Q102	8-729-900-80	TRANSISTOR DTC114ES	
D719	8-719-200-77	DIODE 10E2N		Q103	8-729-142-25	TRANSISTOR 2SD1020HFE	
D720	8-719-000-93	DIODE UZL-7H1		Q104	8-729-620-05	TRANSISTOR 2SC2603-EF	
D721	8-719-912-20	DIODE 1SS120		Q201	8-729-900-74	TRANSISTOR DTC143TS	
D722	8-719-912-20	DIODE 1SS120		Q202	8-729-900-80	TRANSISTOR DTC114ES	
D723	8-719-933-33	DIODE HZS6A1L		Q203	8-729-142-25	TRANSISTOR 2SD1020HFE	
D724	8-719-312-09	DIODE RBA-402		Q204	8-729-620-05	TRANSISTOR 2SC2603-EF	
D801	8-719-912-20	DIODE 1SS120		Q301	8-729-119-76	TRANSISTOR 2SA1175-HFE	
D802	8-719-912-20	DIODE 1SS120		Q302	8-729-900-80	TRANSISTOR DTC114ES	
D803	8-719-912-20	DIODE 1SS120		Q303	8-729-900-80	TRANSISTOR DTC114ES	
D804	8-719-912-20	DIODE 1SS120		Q304	8-729-900-80	TRANSISTOR DTC114ES	
D805	8-719-912-20	DIODE 1SS120		Q305	8-729-119-76	TRANSISTOR 2SA1175-HFE	
D806	8-719-912-20	DIODE 1SS120		Q306	8-729-900-80	TRANSISTOR DTC114ES	
D807	8-719-912-20	DIODE 1SS120		Q307	8-729-900-80	TRANSISTOR DTC114ES	
D808	8-719-933-33	DIODE HZS6A1L		Q308	8-729-900-80	TRANSISTOR DTC114ES	
D809	8-719-933-33	DIODE HZS6A1L		Q309	8-729-620-05	TRANSISTOR 2SC2603-EF	
D810	8-719-912-20	DIODE 1SS120		Q310	8-729-194-57	TRANSISTOR 2SC945-P	
D811	8-719-912-20	DIODE 1SS120 (US, Canadian)		Q311	8-729-194-57	TRANSISTOR 2SC945-P	
D814	8-719-912-20	DIODE 1SS120		Q312	8-729-900-61	TRANSISTOR DTA114ES	
D815	8-719-912-20	DIODE 1SS120		Q701	8-729-900-80	TRANSISTOR DTC114ES	
		< IC >		Q702	8-729-900-80	TRANSISTOR DTC114ES	
IC301	8-759-111-44	IC uPC4570C-1		Q703	8-729-924-90	TRANSISTOR 2SB1370-EF	
IC302	8-752-035-94	IC CXA1331S		Q704	8-729-111-55	TRANSISTOR 2SD2061-E, F	
IC303	8-752-038-02	IC CXA1198AP		Q705	8-729-111-55	TRANSISTOR 2SD2061-E, F	
IC304	8-759-106-56	IC uPC1297CA		Q706	8-729-620-05	TRANSISTOR 2SC2603-EF	
IC305	8-759-945-58	IC RC4558P		Q707	8-729-900-80	TRANSISTOR DTC114ES	
IC306	8-759-945-58	IC RC4558P		Q708	8-729-924-90	TRANSISTOR 2SB1370-EF	
IC601	8-759-634-50	IC M5218AL		Q709	8-729-620-05	TRANSISTOR 2SC2603-EF	
IC602	8-759-634-50	IC M5218AL		Q710	8-729-119-76	TRANSISTOR 2SA1175-HFE	
IC701	8-759-945-58	IC RC4558P		Q711	8-729-140-04	TRANSISTOR 2SB1116A-L	
IC801	8-759-636-61	IC M50963-246SP		Q801	8-729-119-76	TRANSISTOR 2SA1175-HFE	
IC802	8-759-240-69	IC TC4069UBP		Q802	8-729-119-76	TRANSISTOR 2SA1175-HFE	
IC803	8-759-973-95	IC BA6219B		Q803	8-729-900-61	TRANSISTOR DTA114ES	
IC804	8-759-822-09	IC LB1641		Q804	8-729-900-61	TRANSISTOR DTA114ES	
IC805	8-759-822-09	IC LB1641		Q805	8-729-900-61	TRANSISTOR DTA114ES	
		< JACK >		Q806	8-729-900-61	TRANSISTOR DTA114ES	
J101	1-507-854-21	JACK, LARGE TYPE (MICROPHONE LEFT) (US, Canadian)		Q807	8-729-900-65	TRANSISTOR DTA114ES	
	1-507-854-00	JACK, LARGE TYPE (MICROPHONE LEFT) (AEP)		Q808	8-729-900-80	TRANSISTOR DTC114ES	
J201	1-507-854-21	JACK, LARGE TYPE (MICROPHONE RIGHT) (US, Canadian)		Q809	8-729-900-61	TRANSISTOR DTA114ES	
	1-507-854-00	JACK, LARGE TYPE (MICROPHONE RIGHT) (AEP)		Q810	8-729-900-61	TRANSISTOR DTA114ES	
J301	1-573-070-11	JACK, PIN 4P (LINE) (US, Canadian)		Q811	8-729-620-05	TRANSISTOR 2SC2603-EF	
	1-565-258-11	JACK, PIN 4P (LINE) (AEP)		Q812	8-729-620-05	TRANSISTOR 2SC2603-EF	
J302	1-507-796-71	JACK (HEADPHONES)		Q813	8-729-620-05	TRANSISTOR 2SC2603-EF	
				Q814	8-729-620-05	TRANSISTOR 2SC2603-EF	
				Q815	8-729-900-61	TRANSISTOR DTA114ES	
				Q816	8-729-900-61	TRANSISTOR DTA114ES	

MAIN

Ref. No.	Part No.	Description	Remark	Ref. No.	Part No.	Description	Remark
		(RESISTOR)					
R101	1-249-433-11	CARBON 22K	5% 1/4W	R222	1-249-421-11	CARBON 2.2K	5% 1/4W
R102	1-247-887-00	CARBON 220K	5% 1/4W	R223	1-247-840-00	CARBON 2.4K	5% 1/4W
R103	1-249-423-11	CARBON 3.3K	5% 1/4W	R224	1-247-887-00	CARBON 220K	5% 1/4W
R104	1-249-428-11	CARBON 8.2K	5% 1/4W	R225	1-249-421-11	CARBON 2.2K	5% 1/4W
R105	1-247-864-11	CARBON 24K	5% 1/4W	R226	1-247-858-11	CARBON 13K	5% 1/4W
R106	1-249-414-11	CARBON 560	5% 1/4W	R227	1-249-435-11	CARBON 33K	5% 1/4W
R107	1-249-421-11	CARBON 2.2K	5% 1/4W	R228	△1-219-153-11	FUSIBLE 10	5% 1/4W F
R108	1-249-431-11	CARBON 15K	5% 1/4W	R229	1-247-883-00	CARBON 150K	5% 1/4W
R109	1-249-421-11	CARBON 2.2K	5% 1/4W	R230	1-249-434-11	CARBON 27K	5% 1/4W
R110	1-249-417-11	CARBON 1K	5% 1/4W	R231	1-247-870-11	CARBON 43K	5% 1/4W
R111	1-249-429-11	CARBON 10K	5% 1/4W	R232	1-247-868-11	CARBON 36K	5% 1/4W
R112	1-249-424-11	CARBON 3.9K	5% 1/4W	R233	1-249-408-11	CARBON 180	5% 1/4W
R113	1-249-421-11	CARBON 2.2K	5% 1/4W	R234	1-249-417-11	CARBON 1K	5% 1/4W
R114	1-249-429-11	CARBON 10K	5% 1/4W	R301	1-249-417-11	CARBON 1K	5% 1/4W
R115	1-249-421-11	CARBON 2.2K	5% 1/4W	R302	1-249-437-11	CARBON 47K	5% 1/4W
R116	1-249-428-11	CARBON 8.2K	5% 1/4W	R303	1-249-403-11	CARBON 68	5% 1/4W
R117	1-249-435-11	CARBON 33K	5% 1/4W	R304	1-249-429-11	CARBON 10K	5% 1/4W
R118	1-249-403-11	CARBON 68	5% 1/4W	R305	1-215-455-00	METAL 27K	1% 1/6W
R119	1-247-882-11	CARBON 130K	5% 1/4W	R306	1-249-421-11	CARBON 2.2K	5% 1/4W
R120	1-249-426-11	CARBON 5.6K	5% 1/4W	R307	1-249-417-11	CARBON 1K	5% 1/4W
R121	1-249-421-11	CARBON 2.2K	5% 1/4W	R308	1-249-441-11	CARBON 100K	5% 1/4W
R122	1-249-421-11	CARBON 2.2K	5% 1/4W	R309	1-247-864-11	CARBON 24K	5% 1/4W
R123	1-247-840-00	CARBON 2.4K	5% 1/4W	R312	1-249-438-11	CARBON 56K	5% 1/4W
R124	1-247-887-00	CARBON 220K	5% 1/4W	R313	1-249-436-11	CARBON 39K	5% 1/4W
R125	1-249-421-11	CARBON 2.2K	5% 1/4W	R314	1-247-885-00	CARBON 180K	5% 1/4W
R126	1-247-858-11	CARBON 13K	5% 1/4W	R315	1-247-882-11	CARBON 130K	5% 1/4W
R127	1-249-435-11	CARBON 33K	5% 1/4W	R316	1-249-436-11	CARBON 39K	5% 1/4W
R128	△1-219-153-11	FUSIBLE 10	5% 1/4W F	R317	1-247-870-11	CARBON 43K	5% 1/4W
R129	1-247-883-00	CARBON 150K	5% 1/4W	R318	1-247-893-11	CARBON 390K	5% 1/4W
R130	1-249-434-11	CARBON 27K	5% 1/4W	R319	1-247-866-11	CARBON 30K	5% 1/4W
R131	1-247-870-11	CARBON 43K	5% 1/4W	R320	1-247-888-11	CARBON 240K	5% 1/4W
R132	1-247-868-11	CARBON 36K	5% 1/4W	R321	1-247-890-11	CARBON 300K	5% 1/4W
R133	1-249-408-11	CARBON 180	5% 1/4W	R322	1-247-872-11	CARBON 51K	5% 1/4W
R134	1-249-417-11	CARBON 1K	5% 1/4W	R323	1-249-438-11	CARBON 56K	5% 1/4W
R201	1-249-433-11	CARBON 22K	5% 1/4W	R324	1-247-885-00	CARBON 180K	5% 1/4W
R202	1-247-887-00	CARBON 220K	5% 1/4W	R325	1-247-870-11	CARBON 43K	5% 1/4W
R203	1-249-423-11	CARBON 3.3K	5% 1/4W	R326	1-247-880-11	CARBON 110K	5% 1/4W
R204	1-249-428-11	CARBON 8.2K	5% 1/4W	R327	1-247-876-11	CARBON 75K	5% 1/4W
R205	1-247-864-11	CARBON 24K	5% 1/4W	R328	1-249-438-11	CARBON 56K	5% 1/4W
R206	1-249-414-11	CARBON 560	5% 1/4W	R329	1-249-438-11	CARBON 56K	5% 1/4W
R207	1-249-421-11	CARBON 2.2K	5% 1/4W	R330	1-249-409-11	CARBON 220	5% 1/4W
R208	1-249-431-11	CARBON 15K	5% 1/4W	R331	1-249-409-11	CARBON 220	5% 1/4W
R209	1-249-421-11	CARBON 2.2K	5% 1/4W	R332	1-249-422-11	CARBON 2.7K	5% 1/4W
R210	1-249-417-11	CARBON 1K	5% 1/4W	R333	1-249-429-11	CARBON 10K	5% 1/4W
R211	1-249-429-11	CARBON 10K	5% 1/4W	R334	1-247-836-11	CARBON 1.6K	5% 1/4W
R212	1-249-424-11	CARBON 3.9K	5% 1/4W	R335	1-249-422-11	CARBON 2.7K	5% 1/4W
R213	1-249-421-11	CARBON 2.2K	5% 1/4W	R336	1-249-428-11	CARBON 8.2K	5% 1/4W
R214	1-249-429-11	CARBON 10K	5% 1/4W	R338	1-249-441-11	CARBON 100K	5% 1/4W
R215	1-249-421-11	CARBON 2.2K	5% 1/4W	R339	1-249-437-11	CARBON 47K	5% 1/4W
R216	1-249-428-11	CARBON 8.2K	5% 1/4W	R340	1-249-437-11	CARBON 47K	5% 1/4W
R217	1-249-435-11	CARBON 33K	5% 1/4W	R341	1-249-389-11	CARBON 4.7	5% 1/4W
R218	1-249-403-11	CARBON 68	5% 1/4W	R342	1-249-389-11	CARBON 4.7	5% 1/4W
R219	1-247-882-11	CARBON 130K	5% 1/4W	R343	1-249-409-11	CARBON 220	5% 1/4W
R220	1-249-426-11	CARBON 5.6K	5% 1/4W	R344	1-249-409-11	CARBON 220	5% 1/4W
R221	1-249-421-11	CARBON 2.2K	5% 1/4W	R345	1-249-441-11	CARBON 100K	5% 1/4W
				R346	1-249-441-11	CARBON 100K	5% 1/4W
				R347	1-249-429-11	CARBON 10K	5% 1/4W
				R348	1-249-428-11	CARBON 8.2K	5% 1/4W
				R349	1-249-441-11	CARBON 100K	5% 1/4W
				R350	1-249-441-11	CARBON 100K	5% 1/4W

Note:
The components identified by mark △ or dotted line with mark △ are critical for safety. Replace only with part number specified.

Note:
Les composants identifiés par une marque △ sont critiques pour la sécurité. Ne les remplacer que par une pièce portant le numéro spécifié.

MAIN

Ref. No.	Part No.	Description	Remark	Ref. No.	Part No.	Description	Remark
R351	1-249-423-11	CARBON	3. 3K 5% 1/4W	R805	1-249-417-11	CARBON	1K 5% 1/4W
R352	1-249-429-11	CARBON	10K 5% 1/4W	R806	1-247-844-11	CARBON	3. 6K 5% 1/4W
R353	1-249-429-11	CARBON	10K 5% 1/4W	R807	1-249-426-11	CARBON	5. 6K 5% 1/4W
R354	1-249-417-11	CARBON	1K 5% 1/4W	R808	1-249-428-11	CARBON	8. 2K 5% 1/4W
R355	1-249-430-11	CARBON	12K 5% 1/4W	R809	1-249-426-11	CARBON	5. 6K 5% 1/4W
R356	1-249-435-11	CARBON	33K 5% 1/4W	R810	1-247-887-00	CARBON	220K 5% 1/4W
R357	1-249-425-11	CARBON	4. 7K 5% 1/4W	R811	1-247-887-00	CARBON	220K 5% 1/4W
R364	1-249-421-11	CARBON	2. 2K 5% 1/4W	R812	1-249-436-11	CARBON	39K 5% 1/4W
R365	1-249-431-11	CARBON	15K 5% 1/4W	R813	1-247-891-00	CARBON	330K 5% 1/4W
R366	1-249-429-11	CARBON	10K 5% 1/4W	R814	1-247-891-00	CARBON	330K 5% 1/4W
R401	1-249-433-11	CARBON	22K 5% 1/4W	R815	1-249-436-11	CARBON	39K 5% 1/4W
R402	1-249-421-11	CARBON	2. 2K 5% 1/4W	R816	1-247-903-00	CARBON	1M 5% 1/4W
R403	1-249-433-11	CARBON	22K 5% 1/4W	R817	1-249-435-11	CARBON	33K 5% 1/4W
R404	1-249-409-11	CARBON	220 5% 1/4W	R818	1-249-435-11	CARBON	33K 5% 1/4W
R405	1-249-441-11	CARBON	100K 5% 1/4W	R819	1-249-425-11	CARBON	4. 7K 5% 1/4W
R406	1-249-429-11	CARBON	10K 5% 1/4W	R820	1-249-417-11	CARBON	1K 5% 1/4W
R407	1-249-411-11	CARBON	330 5% 1/4W	R821	1-249-413-11	CARBON	470 5% 1/4W
R408	1-249-437-11	CARBON	47K 5% 1/4W	R822	1-249-417-11	CARBON	1K 5% 1/4W
R409	1-249-441-11	CARBON	100K 5% 1/4W	R823	1-249-429-11	CARBON	10K 5% 1/4W
R501	1-249-433-11	CARBON	22K 5% 1/4W	R824	1-249-429-11	CARBON	10K 5% 1/4W
R502	1-249-421-11	CARBON	2. 2K 5% 1/4W	R825	1-249-433-11	CARBON	22K 5% 1/4W
R503	1-249-433-11	CARBON	22K 5% 1/4W	R826	1-249-429-11	CARBON	10K 5% 1/4W
R504	1-249-409-11	CARBON	220 5% 1/4W	R827	1-249-421-11	CARBON	2. 2K 5% 1/4W
R505	1-249-441-11	CARBON	100K 5% 1/4W	R828	1-249-410-11	CARBON	270 5% 1/4W
R506	1-249-429-11	CARBON	10K 5% 1/4W	R829	1-247-887-00	CARBON	220K 5% 1/4W
R507	1-249-411-11	CARBON	330 5% 1/4W	R830	1-249-413-11	CARBON	470 5% 1/4W
R508	1-249-437-11	CARBON	47K 5% 1/4W	R831	1-249-413-11	CARBON	470 5% 1/4W
R509	1-249-441-11	CARBON	100K 5% 1/4W	R832	1-249-435-11	CARBON	33K 5% 1/4W
R601	1-249-409-11	CARBON	220 5% 1/4W	R833	1-249-421-11	CARBON	2. 2K 5% 1/4W
R602	1-249-409-11	CARBON	220 5% 1/4W	R834	1-249-421-11	CARBON	2. 2K 5% 1/4W
R603	1-247-840-00	CARBON	2. 4K 5% 1/4W	R835	1-249-421-11	CARBON	2. 2K 5% 1/4W
R605	1-247-727-11	CARBON	10 5% 1/2W	R836	1-249-421-11	CARBON	2. 2K 5% 1/4W
R701	1-249-433-11	CARBON	22K 5% 1/4W	R837	1-249-429-11	CARBON	10K 5% 1/4W
R702	1-249-425-11	CARBON	4. 7K 5% 1/4W	R838	1-249-429-11	CARBON	10K 5% 1/4W
R703	1-249-420-11	CARBON	1. 8K 5% 1/4W	R839	1-249-433-11	CARBON	22K 5% 1/4W
R704	1-249-426-11	CARBON	5. 6K 5% 1/4W	R840	1-249-429-11	CARBON	10K 5% 1/4W
R705	1-249-427-11	CARBON	6. 8K 5% 1/4W	R841	1-249-429-11	CARBON	10K 5% 1/4W
R706	1-249-419-11	CARBON	1. 5K 5% 1/4W	R842	△1-212-958-00	FUSIBLE	10 5% 1/2W F
R707	1-249-429-11	CARBON	10K 5% 1/4W	R843	1-249-419-11	CARBON	1. 5K 5% 1/4W
R708	1-249-419-11	CARBON	1. 5K 5% 1/4W	R844	1-249-417-11	CARBON	1K 5% 1/4W
R709	1-249-425-11	CARBON	4. 7K 5% 1/4W	R845	1-249-421-11	CARBON	2. 2K 5% 1/4W
R710	1-249-409-11	CARBON	220 5% 1/4W	R846	1-247-887-00	CARBON	220K 5% 1/4W
R711	1-249-417-11	CARBON	1K 5% 1/4W	R847	1-249-410-11	CARBON	270 5% 1/4W
R712	1-249-427-11	CARBON	6. 8K 5% 1/4W	R848	1-249-421-11	CARBON	2. 2K 5% 1/4W
R713	1-249-427-11	CARBON	6. 8K 5% 1/4W				(US, Canadian)
R714	1-249-417-11	CARBON	1K 5% 1/4W	R849	1-249-421-11	CARBON	2. 2K 5% 1/4W
R715	1-249-425-11	CARBON	4. 7K 5% 1/4W	R850	1-249-432-11	CARBON	18K 5% 1/4W
R716	1-249-433-11	CARBON	22K 5% 1/4W	R851	1-249-429-11	CARBON	10K 5% 1/4W
R717	1-249-425-11	CARBON	4. 7K 5% 1/4W				(US, Canadian)
R718	1-249-433-11	CARBON	22K 5% 1/4W	R852	1-249-405-11	CARBON	100 5% 1/4W
							(US, Canadian)
R719	1-249-436-11	CARBON	39K 5% 1/4W	R853	1-249-393-11	CARBON	10 5% 1/4W
R720	1-247-856-00	CARBON	11K 5% 1/4W				(US, Canadian)
R721	1-249-437-11	CARBON	47K 5% 1/4W	R854	1-247-872-11	CARBON	51K 5% 1/4W
R722	1-247-742-11	CARBON	180 5% 1/2W	R855	1-249-427-11	CARBON	6. 8K 5% 1/4W
R723	1-808-065-11	THERMISTOR, POSITIVE		R856	1-249-433-11	CARBON	22K 5% 1/4W
R724	1-808-065-11	THERMISTOR, POSITIVE		R859	△1-212-942-00	FUSIBLE	2. 2 5% 1/2W F
R801	△1-212-954-11	FUSIBLE	6. 8 5% 1/2W F				
R802	△1-212-952-00	FUSIBLE	5. 6 5% 1/2W F				
R803	1-249-426-11	CARBON	5. 6K 5% 1/4W				
R804	1-249-428-11	CARBON	8. 2K 5% 1/4W				

Note:
The components identified by mark Δ or dotted line with mark Δ are critical for safety. Replace only with part number specified.

Note:
Les composants identifiés par une marque Δ sont critiques pour la sécurité. Ne les remplacer que par une pièce portant le numéro spécifié.

MAIN REAL MOTOR PANEL

Ref. No.	Part No.	Description	Remark
R914	1-249-422-11	CARBON 2.7K 5% 1/4W	
R915	1-249-424-11	CARBON 3.9K 5% 1/4W	
R916	1-249-428-11	CARBON 8.2K 5% 1/4W	
R928	1-249-434-11	CARBON 27K 5% 1/4W	
< VARIABLE RESISTOR >			
RV101	1-238-600-11	RES, ADJ, CARBON 10K	
RV102	1-238-016-11	RES, ADJ, CARBON 10K	
RV103	1-238-601-11	RES, ADJ, CARBON 22K	
RV201	1-238-600-11	RES, ADJ, CARBON 10K	
RV202	1-238-016-11	RES, ADJ, CARBON 10K	
RV203	1-238-601-11	RES, ADJ, CARBON 22K	
RV601	1-238-085-11	REA, VAR, CARBON 20K/20K (PHONE LEVEL)	
RV603	1-241-046-11	RES, VAR, CARBON 5K (BIAS)	
RV604	1-241-410-11	RES, VAR, CARBON 20K/50K/50K (REC LEVEL)	
RV605	1-238-904-21	RES, VAR, CARBON 50K/50K (BALANCE)	
RV801	1-238-602-11	RES, ADJ, CARBON 47K	
< RELAY >			
RY301	1-515-683-11	RELAY	
< SWITCH >			
S915	1-554-118-00	SWITCH, PUSH (1 KEY) (MPX FILTER)	
S916	1-572-154-11	SWITCH, ROTARY (DOLBY NR)	
< TRANSFORMER >			
T101	1-433-335-11	TRANSFORMER, BIAS OSCILLATION	
T201	1-433-335-11	TRANSFORMER, BIAS OSCILLATION	
T301	1-433-336-11	TRANSFORMER, BIAS OSCILLATION	
< TEST PIN >			
TP301	* 1-564-506-11	PLUG, CONNECTOR 3P	
TP801	* 1-564-505-11	PLUG, CONNECTOR 2P	
TP802	* 1-564-505-11	PLUG, CONNECTOR 2P	
TP803	* 1-564-506-11	PLUG, CONNECTOR 3P	
< CRYSTAL >			
X801	1-577-358-21	VIBRATOR, CERAMIC 4MHz	

	* 1-632-741-11	REAL MOTOR BOARD *****	
< CAPACITOR >			
C1051	1-124-907-11	ELECT 10uF 20% 50V	
C1052	1-124-907-11	ELECT 10uF 20% 50V	
C1053	1-164-159-11	CERAMIC 0.1uF 50V	
< CONNECTOR >			
CN1051	* 1-564-499-11	PIN, CONNECTOR 6P	
CN1052	* 1-564-718-11	PIN, CONNECTOR (SMALL TYPE) 2P	
CN1053	* 1-564-718-11	PIN, CONNECTOR (SMALL TYPE) 2P	
< RESISTOR >			
R1051	1-249-414-11	CARBON 560 5% 1/4W	

Ref. No.	Part No.	Description	Remark
		< MOTOR >	
M1051	X-3356-638-1	MOTOR (REEL R) ASSY	
M1052	X-3356-604-1	MOTOR (ASSIST) ASSY	

	* A-2006-441-A	PANEL BOARD (including ■ A-F) *****	
	9-911-844-XX	CUSHION	
	* 4-932-502-01	HOLDER, FL TUBE	
	* 4-937-336-01	HOLDER, LED	
< CAPACITOR >			
C901	1-161-494-00	CERAMIC 0.022uF 25V	
C902	1-161-494-00	CERAMIC 0.022uF 25V	
C903	1-162-282-31	CERAMIC 100PF 10% 50V	
C904	1-162-282-31	CERAMIC 100PF 10% 50V	
< CONNECTOR >			
CN901	* 1-580-782-11	CONNECTOR, BOARD TO BOARD	
< DIODE >			
D901	8-719-912-20	DIODE 1SS120	
D902	8-719-912-20	DIODE 1SS120	
D903	8-719-301-38	DIODE SEL2210S (ARL)	
< FLUORESCENT INDICATOR >			
FL901	1-519-658-11	INDICATOR TUBE, FLUORESCENT	
< IC >			
IC901	8-759-636-62	IC M50940-325SP	
IC902	8-741-100-48	IC SBX1610-59	
< TRANSISTOR >			
Q901	8-729-900-61	TRANSISTOR DTA114ES	
Q902	8-729-900-61	TRANSISTOR DTA114ES	
Q903	8-729-900-61	TRANSISTOR DTA114ES	
Q904	8-729-900-61	TRANSISTOR DTA114ES	
Q905	8-729-900-61	TRANSISTOR DTA114ES	
Q906	8-729-900-65	TRANSISTOR DTA144ES	
< RESISTOR >			
R857	1-249-422-11	CARBON 2.7K 5% 1/4W	
R858	1-249-422-11	CARBON 2.7K 5% 1/4W	
R901	1-249-441-11	CARBON 100K 5% 1/4W	
R902	1-249-441-11	CARBON 100K 5% 1/4W	
R903	1-249-441-11	CARBON 100K 5% 1/4W	
R904	1-249-441-11	CARBON 100K 5% 1/4W	
R905	1-249-441-11	CARBON 100K 5% 1/4W	
R906	1-249-441-11	CARBON 100K 5% 1/4W	
R907	1-247-903-00	CARBON 1M 5% 1/4W	
R908	1-249-435-11	CARBON 33K 5% 1/4W	
R909	1-249-411-11	CARBON 330 5% 1/4W	
R910	1-249-429-11	CARBON 10K 5% 1/4W	
R911	1-249-429-11	CARBON 10K 5% 1/4W	
R912	1-249-429-11	CARBON 10K 5% 1/4W	
R913	1-249-429-11	CARBON 10K 5% 1/4W	

PANEL

Ref. No.	Part No.	Description	Remark		
R917	1-249-422-11	CARBON	2.7K	5%	1/4W
R918	1-249-424-11	CARBON	3.9K	5%	1/4W
R919	1-249-428-11	CARBON	8.2K	5%	1/4W
R920	1-249-434-11	CARBON	27K	5%	1/4W
R921	1-249-422-11	CARBON	2.7K	5%	1/4W
R922	1-249-424-11	CARBON	3.9K	5%	1/4W
R923	1-249-428-11	CARBON	8.2K	5%	1/4W
R924	1-249-434-11	CARBON	27K	5%	1/4W
R925	1-249-422-11	CARBON	2.7K	5%	1/4W
R926	1-249-424-11	CARBON	3.9K	5%	1/4W
R927	1-249-428-11	CARBON	8.2K	5%	1/4W
R929	1-249-405-11	CARBON	100	5%	1/4W
R930	1-249-405-11	CARBON	100	5%	1/4W
R931	1-249-405-11	CARBON	100	5%	1/4W
R932	1-249-405-11	CARBON	100	5%	1/4W
R933	1-249-405-11	CARBON	100	5%	1/4W
		< SWITCH >			
S701	1-554-118-00	SWITCH, PUSH (1 KEY) (POWER)			
S801	1-571-520-11	SWITCH, SLIDE (DIRECTION)			
S802	1-571-520-11	SWITCH, SLIDE (TIMER)			
S901	1-554-303-21	SWITCH, TACTILE (OPEN/CLOSE △)			
S902	1-554-303-21	SWITCH, TACTILE (■)			
S903	1-554-303-21	SWITCH, TACTILE (▶▶)			
S904	1-554-303-21	SWITCH, TACTILE (◀◀)			
S905	1-554-303-21	SWITCH, TACTILE (REC ●)			
S906	1-554-303-21	SWITCH, TACTILE (<◁)			
S907	1-554-303-21	SWITCH, TACTILE (>▷)			
S908	1-554-303-21	SWITCH, TACTILE (REC MUTE ○)			
S909	1-554-303-21	SWITCH, TACTILE (ARL)			
S910	1-554-303-21	SWITCH, TACTILE (FADER)			
S911	1-554-303-21	SWITCH, TACTILE (PAUSE ■■)			
S912	1-554-303-21	SWITCH, TACTILE (RESET)			
S913	1-554-303-21	SWITCH, TACTILE (MEMORY)			
S914	1-554-303-21	SWITCH, TACTILE (DISPLAY MODE)			
		< VIBRATOR >			
X901	1-577-358-21	VIBRATOR, CERAMIC 4MHz			

Ref. No.	Part No.	Description	Remark
		MISCELLANEOUS	

52	△1-450-100-11	TRANSFORMER, POWER (US, Canadian)	
	△1-450-399-11	TRANSFORMER, POWER (AEP)	
58	△1-551-506-XX	CORD, POWER (US, Canadian)	
	△1-555-795-00	CORD, POWER, EURO PLUG (AEP)	
518	8-719-980-85	DIODE SLF-325C	
HRPE1001	A-2003-722-A	SLIDER (R4) COMPLETE ASSY	
IC1001	8-749-920-97	IC PHOTO REFLECTOR GP2S22B	
IC1002	8-749-920-97	IC PHOTO REFLECTOR GP2S22B	
IC803	8-759-973-95	IC BA6219B	
M1051	X-3356-638-1	MOTOR (REEL R) ASSY	
M1052	X-3356-604-1	MOTOR (ASSIST) ASSY	
M1053	X-3356-646-1	MOTOR (CAPSTAN V1) ASSY	
S1001	1-466-525-11	ENCODER, ROTARY	

ACCESSORY & PACKING MATERIAL

- 1-559-533-11 CORD, CONNECTION
- * 3-350-830-01 CUSHION
- * 3-366-700-21 INDIVIDUAL CARTON (US, Canadian)
- * 3-366-700-21 INDIVIDUAL CARTON (AEP)
- 3-703-450-01 INSTRUCTION (US)
- * 3-704-343-01 SHEET (STANDARD), PROTECTION
- 3-753-080-11 MANUAL, INSTRUCTION (ENGLISH, F, E, P) (AEP)
- 3-753-080-21 MANUAL, INSTRUCTION (ENGLISH) (US)
- 3-753-080-31 MANUAL, INSTRUCTION (FRENCH) (Canadian)
- 3-753-080-41 MANUAL, INSTRUCTION (D, NL, S, I) (AEP)

HARDWARE LIST

- # 1 7-685-534-19 SCREW +BTP 2.6X8 TYPE2 N-S
- # 2 7-682-547-04 SCREW +BVTT 3X6 (S)
- # 3 7-621-849-00 SCREW (BV/RING)
- # 4 7-685-645-79 SCREW +BVTP 3X6 TYPE2 N-S
- # 5 7-621-773-93 SCREW (PANEL 2.6 TP2)
- # 6 7-685-646-79 SCREW +BVTP 3X8 TYPE2 N-S
- # 7 7-621-255-35 SCREW +BVTT 2X5 (S)
- # 8 7-621-770-67 SCREW +BVTT 2.6X6 (S)
- #10 7-685-131-19 SCREW +BTP 2.6X4 TYPE2 N-S
- #11 7-685-133-19 SCREW +BTP 2.6X6 TYPE2 N-S
- #12 7-621-255-20 SCREW +BVTT 2X4 (S)

ex. F : FRENCH D : GERMAN
 E : SPANISH NL : DUTCH
 P : PORTUGUESE S : SWEDISH
 I : ITALIAN

<p>Note: The components identified by mark △ or dotted line with mark △ are critical for safety. Replace only with part number specified.</p>	<p>Note: Les composants identifiés par une marque △ sont critiques pour la sécurité. Ne les remplacer que par une pièce portant le numéro spécifié.</p>
---	---

