

TC-RX79/RX79ES

SERVICE MANUAL

US Model
Canadian Model
TC-RX79ES
AEP Model
TC-RX79



Dolby noise reduction manufactured under license from Dolby Laboratories Licensing Corporation. "DOLBY" and the double-D symbol  are trademarks of Dolby Laboratories Licensing Corporation.

Model Name Using Similar Mechanism	TC-RX77/RX77ES
Tape Transport Mechanism Type	TCM-200R10

SPECIFICATIONS

Recording system	4-track 2-channel stereo
Fast winding time	Approx. 90 sec. (with Sony C-60 cassette)
Bias	AC bias
Heads	Erasing head × 1 (ferrite head) Playback/Recording head × 1 (LA head)
Motors	Capstan motor × 1 (DC servo motor) Reel motor × 1 (DC motor) ASIST (mechanical drive) motor × 1 (DC motor)

Signal-to-noise ratio (at peak level)

Cassette (Dolby NR OFF)	Type IV (Sony Metal-Select)	Type II (Sony UX-S)	Type I (Sony HF-S)
	59 dB	58 dB	56 dB

Measured at peak level weighted without NR. The S/N is improved by about 15 dB at 500 Hz and by about 20 dB about 1 kHz with Dolby-C NR on. And by 5 dB at 1 kHz and by 10 dB about 5 kHz with Dolby-B NR on.

Harmonic distortion	0.4% (with Sony Type I, 160 nWb/m, 315 Hz, 3rd H.D.) 1.8% (with Sony Type IV, 250 nWb/m, 315 Hz, 3rd H.D.)
---------------------	---

Frequency response (Dolby NR OFF)

Type IV cassette (Sony Metal-Select)	20 - 20,000 Hz (±3 dB, IEC) 30 - 15,000 Hz [±3 dB (-4dB) recording]
Type II cassette (Sony UX-S)	25 - 18,000 Hz (±3 dB, IEC)
Type I cassette (Sony HF-S)	25 - 16,000 Hz (±3 dB, IEC)

Wow and flutter	±0.09% W.Peak (IEC) 0.06% W.RMS (NAB) ±0.16% W.Peak (DIN)
-----------------	---

Inputs

Line inputs (phono jacks)	Sensitivity	77.5 mV
	Input impedance	47 k ohms
Microphone inputs (phone jacks)	Sensitivity (For a low-impedance microphone)	0.25 mV

Outputs

Line outputs (phono jacks)	Rated output level	0.32 V at a load impedance of 47 k ohms
	Load impedance	Over 10 k ohms
Headphones (stereo phone jack)	Output level	0-1.25 mW at a load impedance of 32 ohms

General

Power requirements
RX79ES : 120 V AC, 60Hz (US, Canadian models)
RX79 : 220V AC, 50/60Hz (AEP model)

Power consumption 20 W

Dimensions Approx. 430 × 123 × 300 mm (w/h/d)
(17 × 4⁷/₈ × 11⁷/₈ inches)
including projecting parts and controls

Weight Approx. 4.7 kg (10 lbs 6 oz)

Supplied accessory

Audio connecting cords (2)

Design and specifications subject to change without notice.

STEREO CASSETTE DECK
SONY®

TABLE OF CONTENTS

<u>Section</u>	<u>Title</u>	<u>Page</u>
Specification		1
Model Identification		2
Safety Check-Out		2
1. GENERAL		3
2. DISASSEMBLY		4
3. ADJUSTMENTS		7
3-1. Mechanical Adjustment		7
3-2. Electrical Adjustment		7
4. DIAGRAMS		
4-1. Semiconductor Lead Layout		11
4-2. Circuit Boards Location		11
4-3. IC Block Diagram		12
4-4. Printed Wiring Boards		13
4-5. Schematic Diagram		17
4-6. Block Diagram		22
5. EXPLODED VIEWS		
5-1. Front Panel Section		25
5-2. Chassis Section		26
5-3. Mechanism Section (TCM-200R10)		27
5-4. Mechanism Section (TCM-200R10)		28
6. ELECTRICAL PARTS LIST		29

MODEL IDENTIFICATION

— Specification Label —

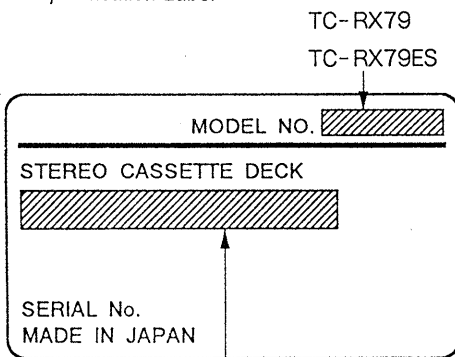

US, Canadian Model: AC: 120V 60Hz 30W
 AEP Models: AC: 220 - 230V~50/60 Hz

SAFETY-RELATED COMPONENT WARNING!!

COMPONENTS IDENTIFIED BY MARK OR DOTTED LINE WITH MARK ON THE SCHEMATIC DIAGRAMS AND IN THE PARTS LIST ARE CRITICAL TO SAFE OPERATION. REPLACE THESE COMPONENTS WITH SONY PARTS WHOSE PART NUMBERS APPEAR AS SHOWN IN THIS MANUAL OR IN SUPPLEMENTS PUBLISHED BY SONY.

SAFETY CHECK-OUT

After correcting the original service problem, perform the following safety check before releasing the set to the customer:

Check the antenna terminals, metal trim, "metallized" knobs, screws, and all other exposed metal parts for AC leakage. Check leakage as described below.

LEAKAGE TEST

The AC leakage from any exposed metal part to earth ground and from all exposed metal parts to any exposed metal part having a return to chassis, must not exceed 0.5 mA (500 microampers). Leakage current can be measured by any one of three methods.

1. A commercial leakage tester, such as the Simpson 229 or RCA WT-540A. Follow the manufacturers' instructions to use these instruments.
2. A battery-operated AC milliammeter. The Data Precision 245 digital multimeter is suitable for this job.
3. Measuring the voltage drop across a resistor by means of a VOM or battery-operated AC voltmeter. The "limit" indication is 0.75 V, so analog meters must have an accurate low-voltage scale. The Simpson 250 and Sanwa SH-63Trd are examples of a passive VOM that is suitable. Nearly all battery operated digital multimeters that have a 2V AC range are suitable. (See Fig. A)

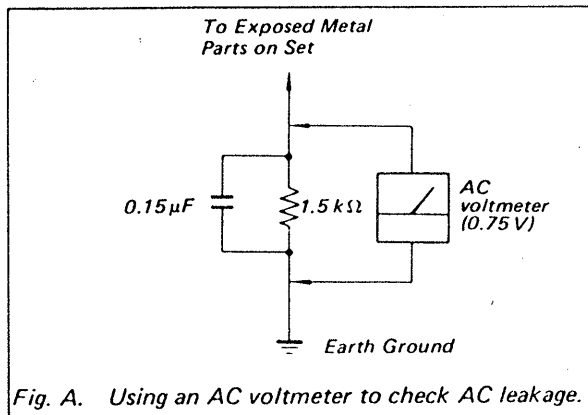

Fig. A. Using an AC voltmeter to check AC leakage.

ATTENTION AU COMPOSANT AYANT RAPPORT À LA SÉCURITÉ!

LES COMPOSANTS IDENTIFIÉS PAR UNE MARQUE SUR LES DIAGRAMMES SCHÉMATIQUES ET LA LISTE DES PIÈCES SONT CRITIQUES POUR LA SÉCURITÉ DE FONCTIONNEMENT. NE REMPLACER CES COMPOSANTS QUE PAR DES PIÈCES SONY DONT LES NUMÉROS SONT DONNÉS DANS CE MANUEL OU DANS LES SUPPLÉMENTS PUBLIÉS PAR SONY.

SECTION 1 GENERAL

This section is extracted from instruction manual.

Front Panel

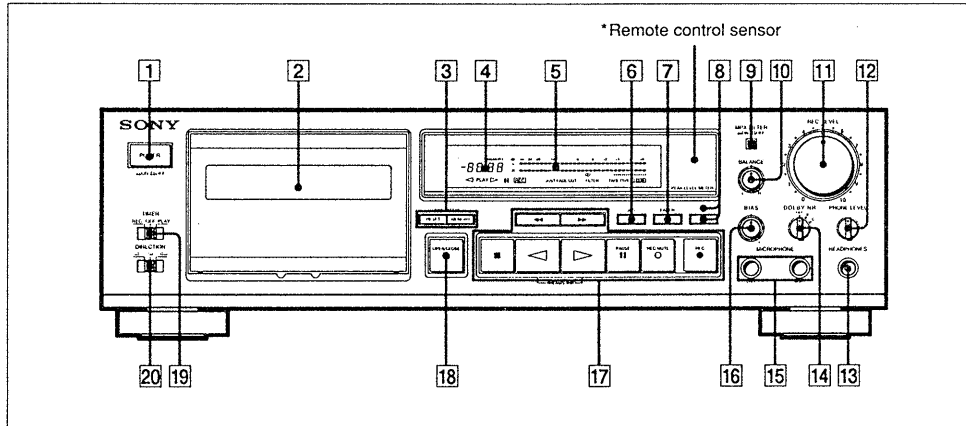

For details, refer to the page number indicated in parenthesis.

- 1 POWER switch
- 2 Cassette holder
- 3 Counter buttons
RESET button (page 10)
MEMORY button (pages 9 and 10)
- 4 LINEAR COUNTER (page 10)
- 5 PEAK LEVEL METER (page 15)
- 6 JFS (Just Fade-out) button (page 14)
- 7 FADER button (page 13)
- 8 ARL (automatic recording level) control and indicator (page 11)
- 9 MPX FILTER button (page 15)
- 10 BALANCE control (page 11)
- 11 REC (recording) LEVEL control (pages 11 and 15)
- 12 PHONE (headphones) LEVEL control (page 7)
- 13 HEADPHONES jack (stereo phone jack) (page 7)
- 14 DOLBY NR (noise reduction) switch (pages 7 and 11)
- 15 MICROPHONE jacks (phone jacks)
- 16 BIAS control (page 15)
- 17 Tape operation buttons
◀◀ (leftward fast winding) button
▶▶ (rightward fast winding) button
■ (stop) button
◀ (reverse play) button
▶ (forward play) button
|| PAUSE button
○ REC MUTE (record muting) button (page 17)
● REC (recording) button
- 18 OPEN/CLOSE button
- 19 TIMER switch (page 18)
- 20 DIRECTION mode switch (pages 7 and 11)

*Remote control sensor
You can remotely control this cassette deck with:
— A remote commander that came with a Sony amplifier or receiver if it has the mark and cassette deck control capability.
— An optional Sony remote commander with the mark and cassette deck control capability.

Hook-up Example

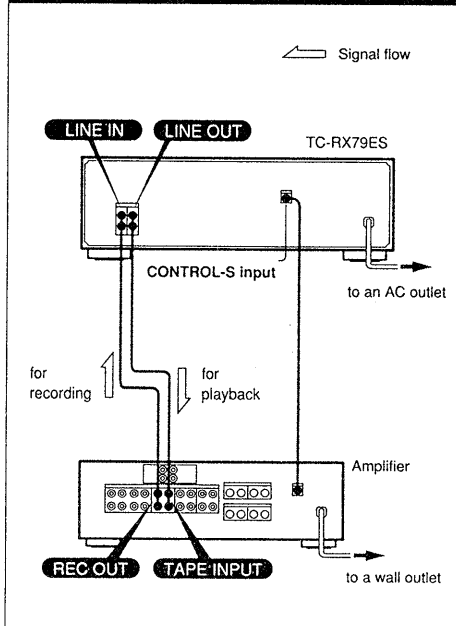

Features

- For higher quality recording/playback**
 - The Dolby HX PRO* system which improves the linearity of the tape's high-range response during recording.
 - B and C type Dolby NR* systems which reduce tape noise.
 - Bias calibration to achieve the optimum bias current setting for any tape.
 - Ceramic cassette holder for improved stability of tape running during playback and recording.
- For your convenience**
 - Quick reversing at the end of a tape to minimize interruptions during playback and recording.
 - The Multi-AMS and Memory Play functions which provide easy access to a desired selection.
 - Timer-activated playback and recording through the use of an optional timer.
 - Automatic switching between line and microphone input when recording with a microphone.
- For easier operation**
 - Fade-in and Fade-out functions to start and end recordings with a professional touch.
 - The Just Fade Out System which provides an automatic fade-out ending to any recording.
 - Easy-to-read linear counter which shows the elapsed recording or playing time.

SECTION 2 DISASSEMBLY

Note: Follow the disassembly procedure in the numerical order given.

Unscrew the four case attachment screws M3 × 8 and remove the upper case.

MAIN BOARD

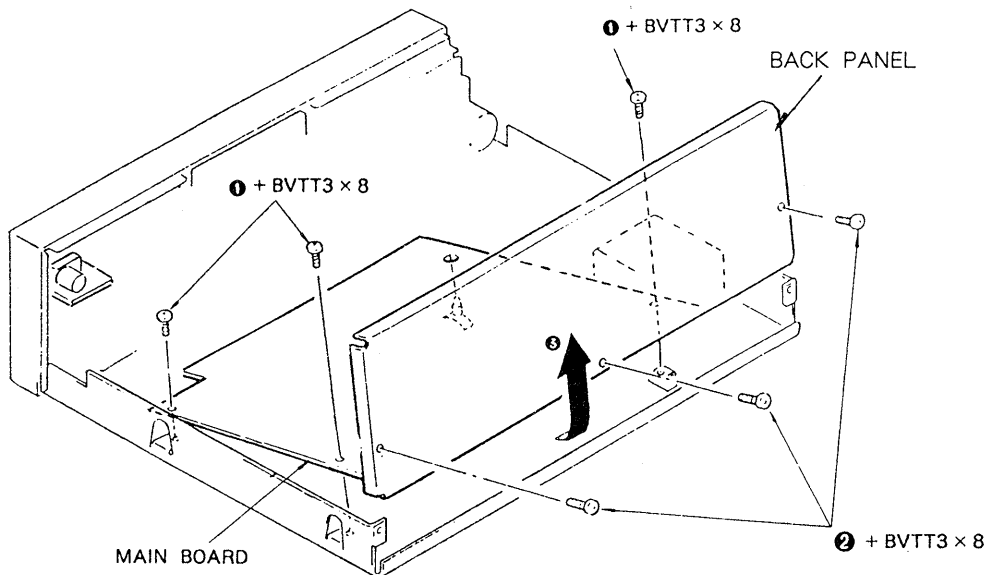

MECHANISM

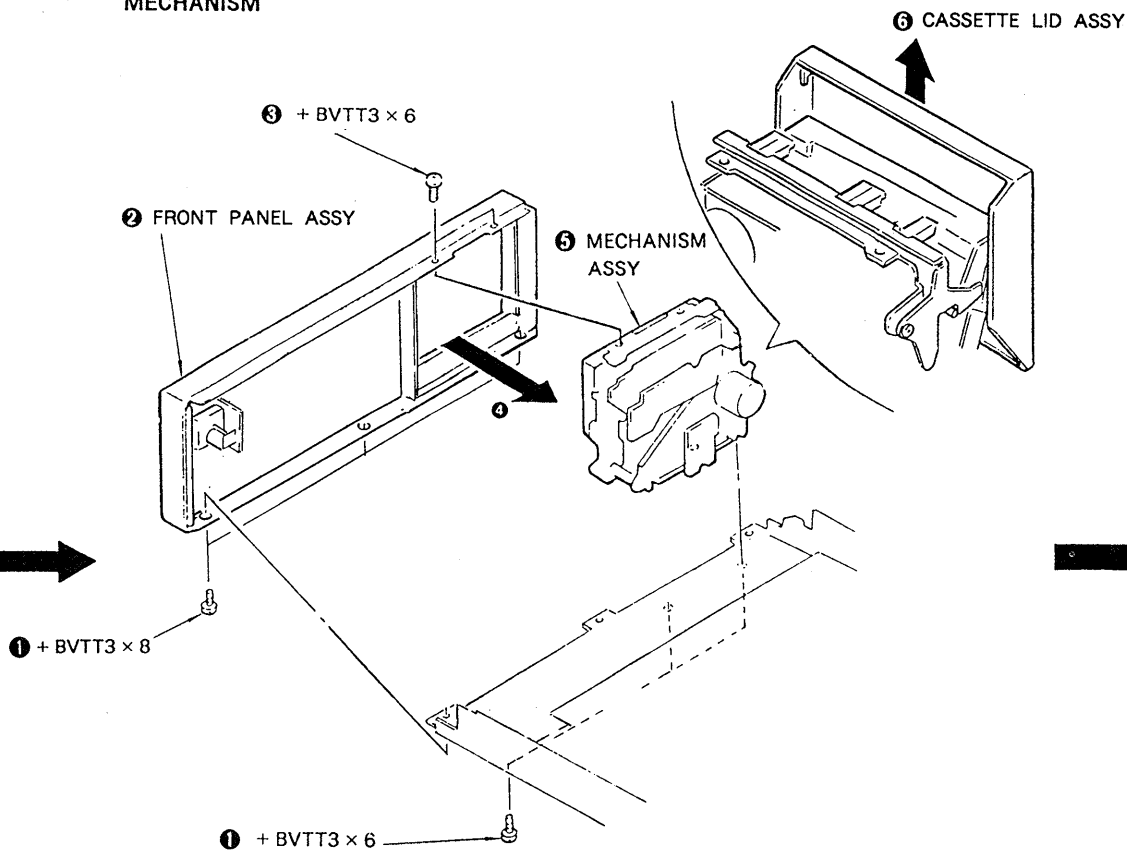

CASSETTE HOLDER

③ Push LEVER (LIFTER) in the direction of arrow and remove CASSETTE HOLDER.

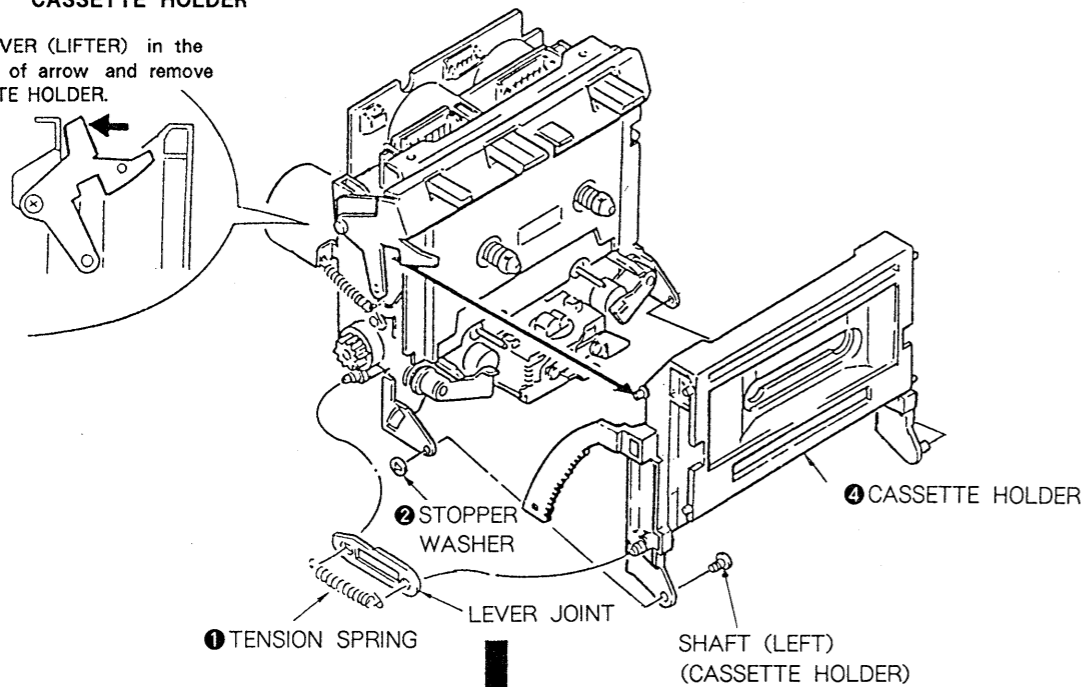

ORNAMENTAL PLATE

② Push LEVER (LIFTER) in the direction of arrow and remove ORNAMENTAL PLATE.

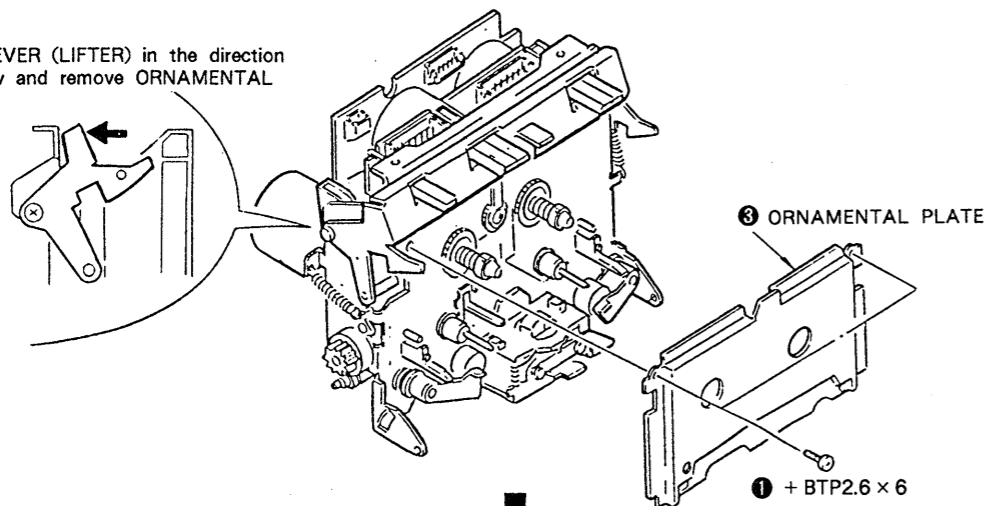

PINCH LEVER/HEAD

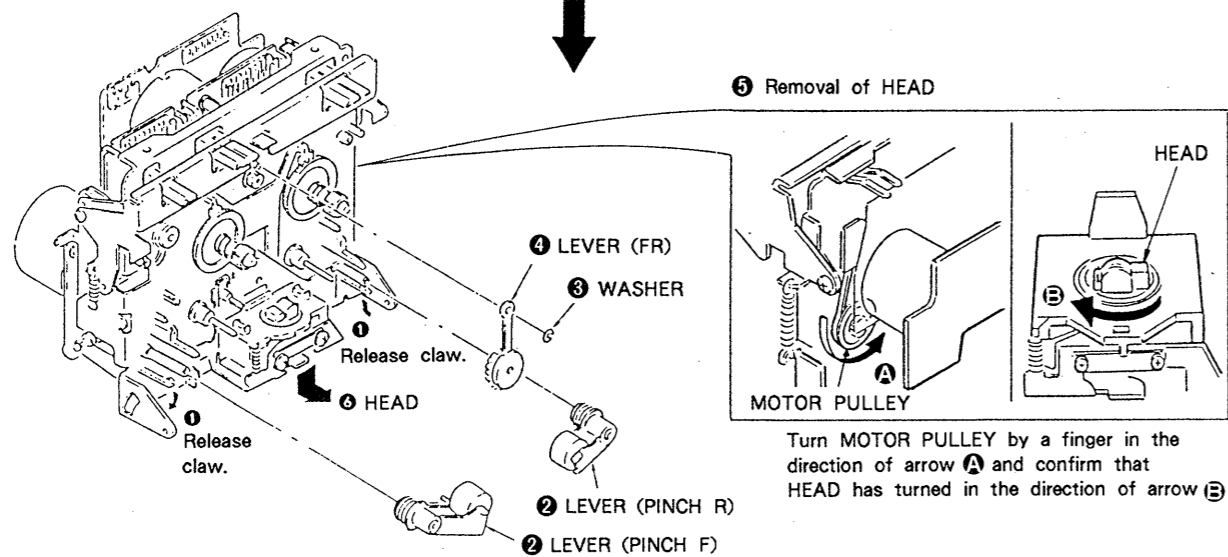

CAPSTAN MOTOR/FLYWHEEL

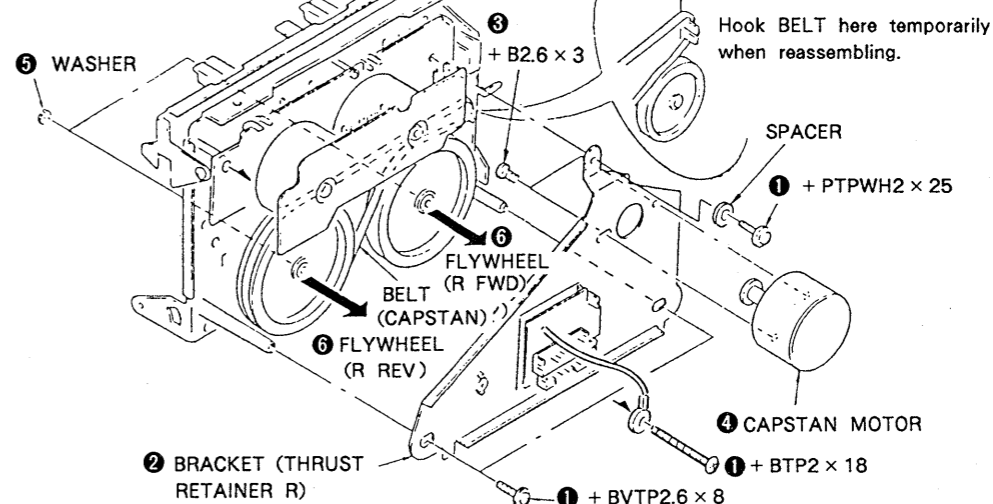

REEL and ASSIST MOTORS

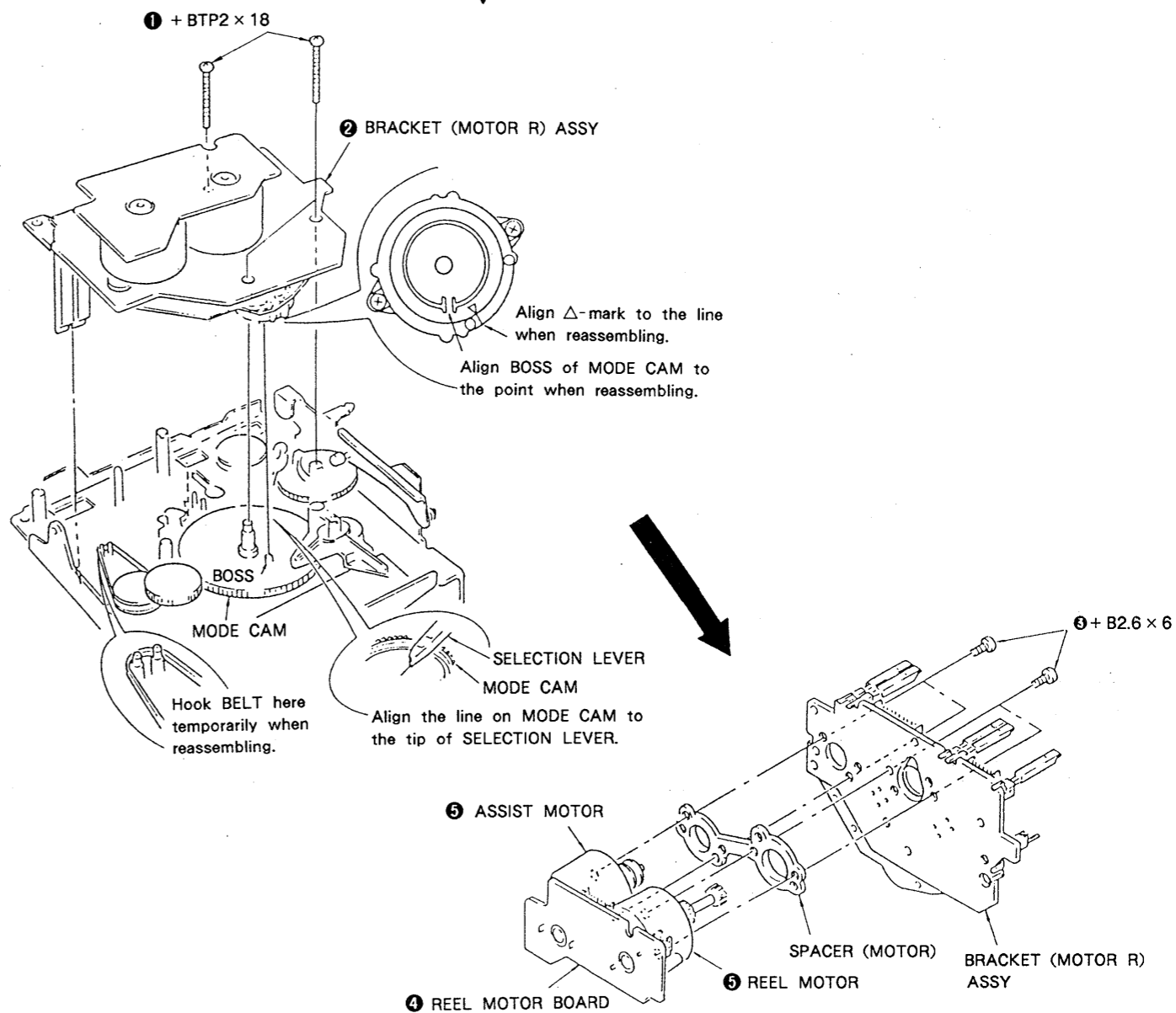

SECTION 3 ADJUSTMENTS

3-1. MECHANICAL ADJUSTMENTS

PRECAUTION

1. Clean the following parts with a denatured-alcohol-moistened swab :

record/playback head	pinch roller
erase head	rubber belts
capstan	idler
2. Demagnetize the record/playback head with a head demagnetizer.
3. Do not use a magnetized screwdriver for the adjustments.
4. After the adjustments, apply suitable locking compound to the parts adjusted.

TORQUE MEASUREMENT

Torque	Torque meter	Meter reading
FWD	CQ-102C	30 - 60g·cm (0.42 - 0.83oz·inch)
FWD Back tension	CQ-102C	1 - 5g·cm (0.014 - 0.069oz·inch)
REV	CQ-102RC	30 - 60g·cm (0.42 - 0.83oz·inch)
REV Back tension	CQ-102RC	1 - 5g·cm (0.014 - 0.069oz·inch)
FF, REW	CQ-201B	65 - 90·cm (0.9 - 1.25oz·inch)

3-2. ELECTRICAL ADJUSTMENT

Note : The adjustment should be performed in the order given in the service manual. As a rule, adjustments about playback should be performed before those about recording. The adjustments should be performed for both L-CH and R-CH.

- Switches and controls should be set as follows unless otherwise specified.

DOLBY NR switch : OFF
DIRECTION switch : →

- Standard Record :

Deliver the standard input signal level to the input jack and set the REC LEVEL control to obtain the standard output signal level.

—Record Mode—

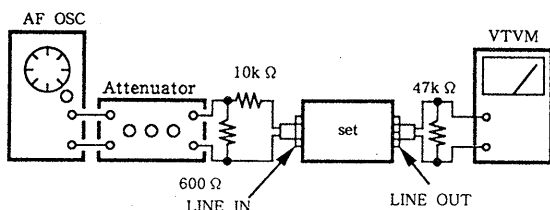

Standard Input Level

input terminal	LINE IN
source impedance	10k Ω
input level	0.25V (-10dB)

Standard Output Level

output terminal	LINE OUT
load impedance	47k Ω
output level	0.32V (-7.7dBs (m))

Test Tape

Type	Signal	Used for
P-4-A100	10kHz, -10dB	Azimuth Adjustment
P-4-L300	315Hz, 0dB	PB Level Adjustment
WS-48B	3kHz, 0dB	Tape Speed Adjustment

Test Mode

1. Put the set into the test mode by shorting test point TP801 (TEST) of the main board during the set is turned off.
2. Remove the short after the Electrical Adjustment is completed.

Record/Playback Head Azimuth Adjustment

Procedure :

1. Mode : FWD playback

Test tape
P-4-A100
(10kHz, -10dB)

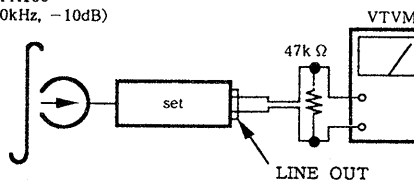

2. Turn the adjustment screw for the maximum output levels. If these levels do not match, turn the adjustment screw until both of output levels match together within 1dB.

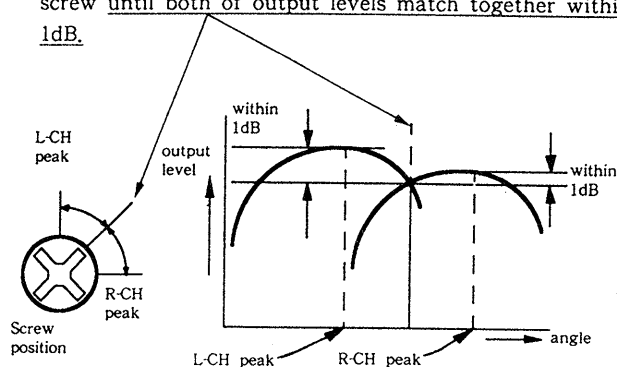

3. Phase Check
Mode : playback

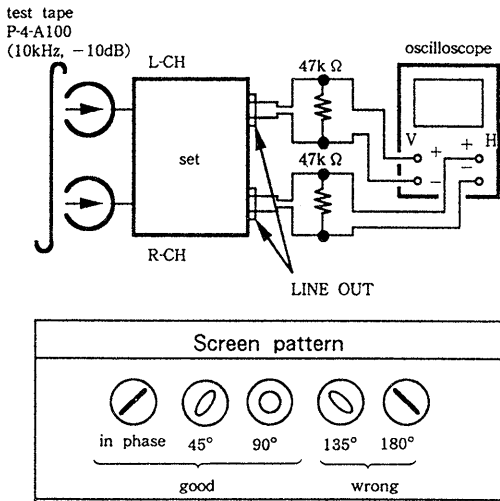

4. Set in the REV mode and repeat the step 1-3.
5. After the adjustment, lock the screws with locking compound.

Adjustment Location : Record/Playback head

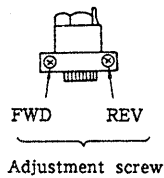

Tape Speed Adjustment

Setting :
test pin TP801 : short

Procedure :
Mode : playback

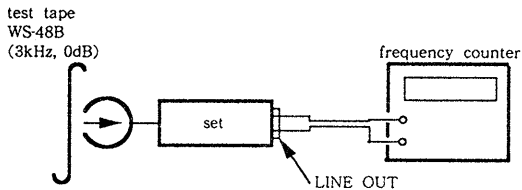

1. Set to FWD playback mode.
2. Adjust motor rear side (variable resistor) so that the frequency counter reading becomes $3,000 \pm 15\text{Hz}$.

Adjustment Location :
motor rear side

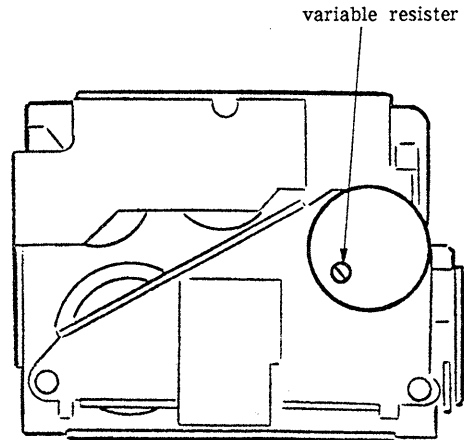

Playback Level Adjustment

Procedure :
Mode : playback

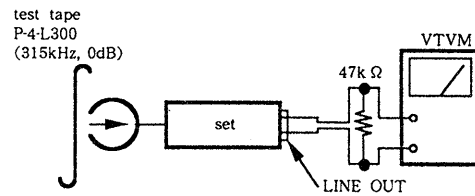

Adjust RV101 (L-ch) and RV201 (R-ch) so that the reading on VTVM meets the adjustment limits below.

Adjustment Limits :

LINE OUT level : $-7.7\text{dBs(m)} \pm 0.5\text{dB}(0.3\sim 0.34\text{V})$

Level difference between channels : less than 0.5dB

Check that the LINE OUT level does not change even if Playback and Stop operation is repeated several times.

Adjustment Location : Main board

Bias Current Adjustment

Procedure :

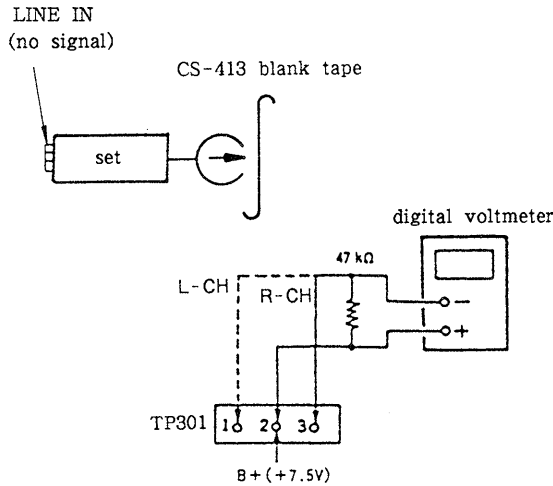

1. Set RV103 and RV203 to mechanical center and turn the set recording mode.
2. Connect digital voltmeter as shown by the following table.
3. Adjust the following transformers for the minimum readings on the digital voltmeter.

	Mesurement Point	Adjustment Part	Value
L-ch	① and ②, TP301	T101	not more than
R-ch	② and ③, TP301	T201	130mV

Adjustment Location : Main board

Record Bias Adjustment

Setting :

REC LEVEL control : Standard Record (See page 7.)
test pin TP801 : short

Procedure :

1. Mode : record

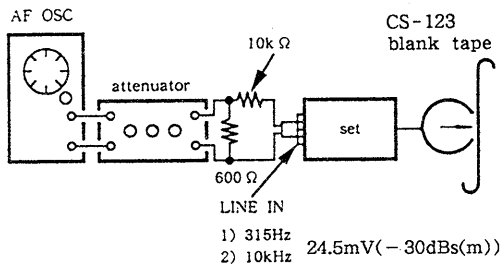

2. Mode : playback

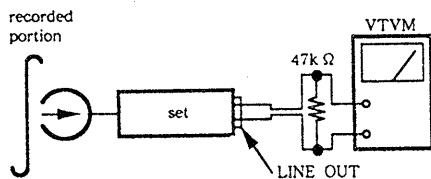

Playback the signal recorded in step 1.

Confirm that the 10kHz playback output is $0 \pm 0.5\text{dB}$ relative to the 315Hz output. If necessary, adjust RV103 (L-ch) and RV203 (R-ch) for repeat the steps given above.

Adjustment Location : Main board

Record Level Adjustment

Setting :

REC LEVEL control : Standard Record (See page 7.)
test pin TP801 : short

Procedure :

1. Mode : record

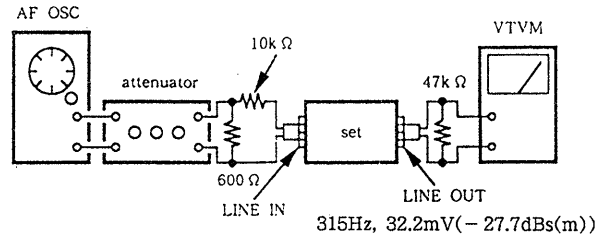

2. Mode : playback

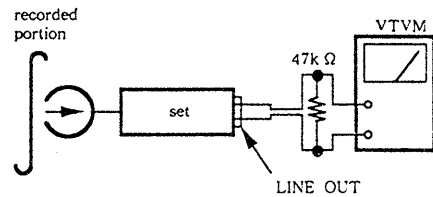

3. Playback the signal recorded in step1.

Confirm that the signal level is within the adjustment limits below. If necessary, adjust RV102 (L-ch) and RV202 (R-ch) repeat the step1-2.

Adjustment Limits : $-27.7\text{dBs(m)} \pm 0.5\text{dB}(30.4 \sim 34.2\text{mV})$

Adjustment Location : Main board

Quick Reverse Sensitivity Adjustment

Conditions :

DIRECTION MODE switch : \rightleftarrows

Adjustment procedure :

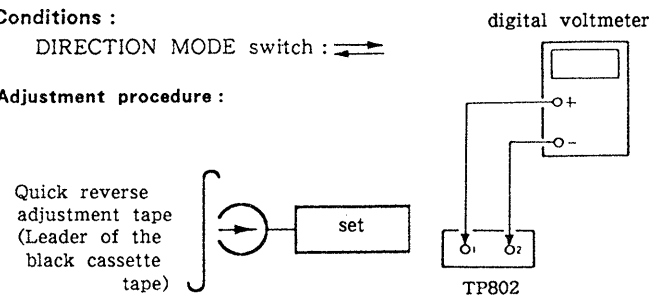

1. Connect the digital voltmeter to test point TP802.
2. Load quick reverse adjustment tape and play back the leading portion in FWD mode.
3. Adjust the RV801 for $4.5 \pm 0.5\text{V}$ reading on the digital voltmeter.
4. Play back quick reverse adjustment tape in FWD mode again.
5. Confirm that the reading on the digital voltmeter is "L" level at the magnetic portion of the tape.
6. Confirm that the tape stop around the tape end (border of the leading and the magnetic portions).

Adjustment Location : Main board

Adjustment Parts Location

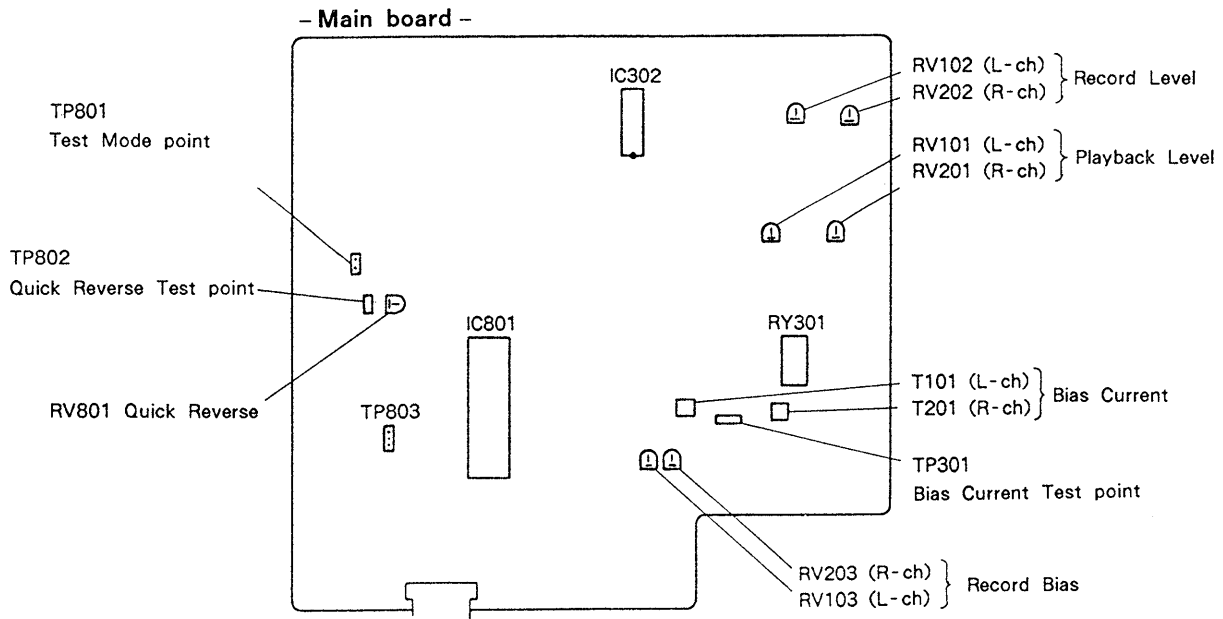

SECTION 4 DIAGRAMS

4-1. SEMICONDUCTOR LEAD LAYOUTS

DTA114ES
DTA144ES
DTC114ES
DTC143TS
2SA1175-HFE
2SB1116A-L
2SC2603-EF
2SC945-P
2SD1020-HFE

RBA-402

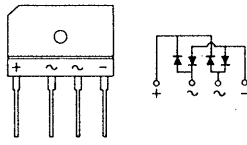

SEL2210S-C

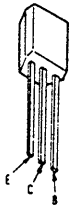
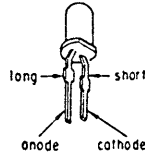

HZS6A1L
HZS7A1L
UZL-7H1
UZL-12M1

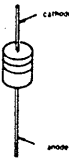

GP2S22B

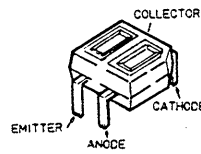

2SB1094-LK
2SD2012

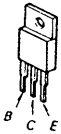

IN4148N
10E2N
21DQ05

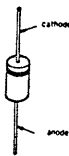

4-2. CIRCUIT BOARDS LOCATION

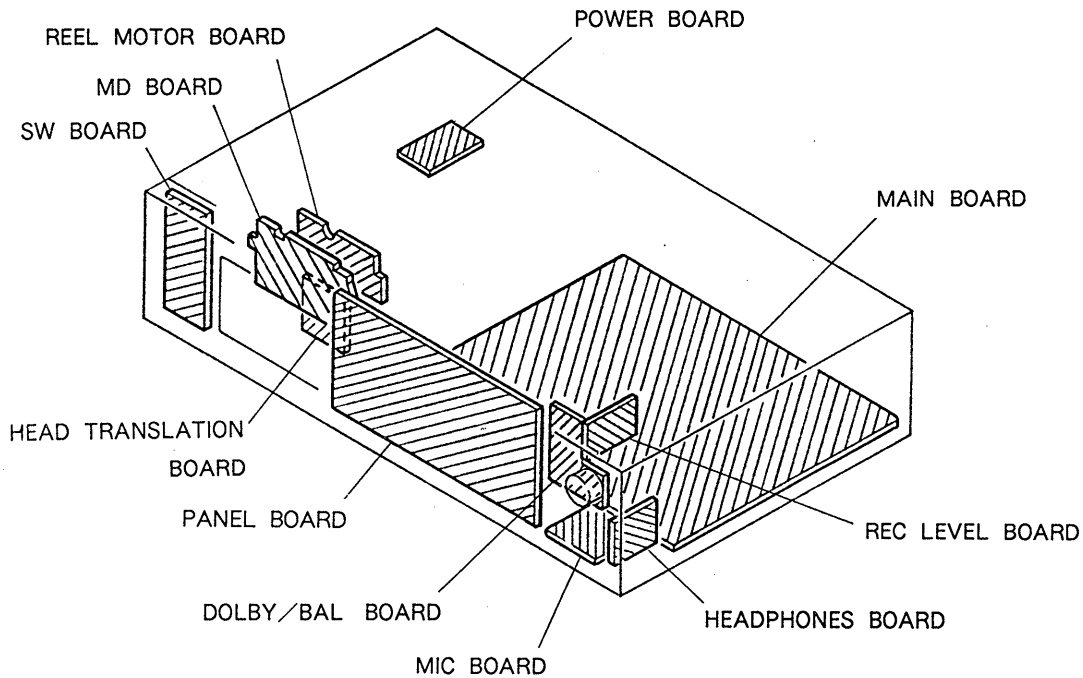

4-3. IC BLOCK DIAGRAM

- IC803 BA6219B
- IC804, 805 LB1641

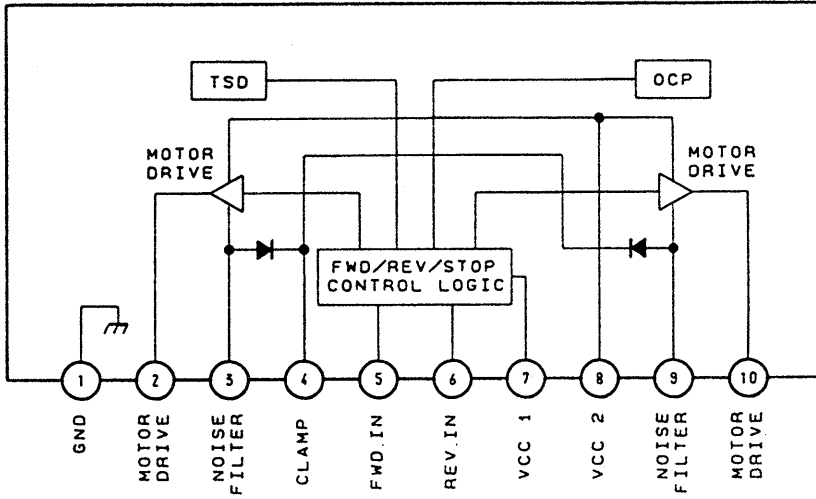

Ref. No.	Location	Ref. No.	Location
D101	F-20	Q102	C-21
D201	F-19	Q103	C-19
D301	D-20	Q104	C-18
D302	D-21	Q201	F-17
D303	E-19	Q202	D-20
D304	G-20	Q203	C-19
D305	D-18	Q204	C-17
D306	D-16	Q301	F-19
D307	D-16	Q302	D-16
D308	D-17	Q303	D-16
D309	H-17	Q304	D-17
D701	C-24	Q305	H-20
D702	C-24	Q306	I-20
D703	C-24	Q307	I-20
D704	C-24	Q308	I-20
D705	C-23	Q309	G-20
D706	B-24	Q310	I-17
D707	E-25	Q311	H-17
D712	D-24	Q312	D-21
D713	D-24	Q701	E-25
D714	D-24	Q702	D-23
D715	D-24	Q703	A-23
D716	D-25	Q704	A-23
D717	B-25	Q705	E-24
D718	C-25	Q706	E-24
D719	D-25	Q707	D-25
D720	D-25	Q708	A-24
D721	E-25	Q709	B-25
D722	B-22	Q710	D-25
D723	C-22	Q711	C-25
D724	D-25	Q801	G-24
D801	H-23	Q802	I-25
D802	H-23	Q803	I-25
D803	H-23	Q804	I-25
D804	H-25	Q805	I-25
D805	H-25	Q806	I-25
D806	F-24	Q807	E-21
D807	E-22	Q808	E-21
D808	G-22	Q809	F-21
D809	G-22	Q810	G-21
D810	E-21	Q811	F-22
D811	F-21	Q812	F-22
D814	D-17	Q813	F-23
D815	D-17	Q814	F-24
D901	G-9	Q815	I-22
D902	G-9	Q816	E-21
D903	I-7	Q901	H-9
D1051	F-4	Q902	H-9
		Q903	H-9
IC301	F-17	Q904	H-9
IC302	C-20	Q905	H-9
IC303	C-17	Q906	H-7
IC304	C-18		
IC305	F-19		
IC306	F-19		
IC601	C-13		
IC602	C-11		
IC701	B-23		
IC801	G-23		
IC802	H-24		
IC803	G-25		
IC804	G-24		
IC805	H-22		
IC901	H-11		
IC902	H-7		
IC1001	H-2		
IC1002	H-4		
Q101	E-18		

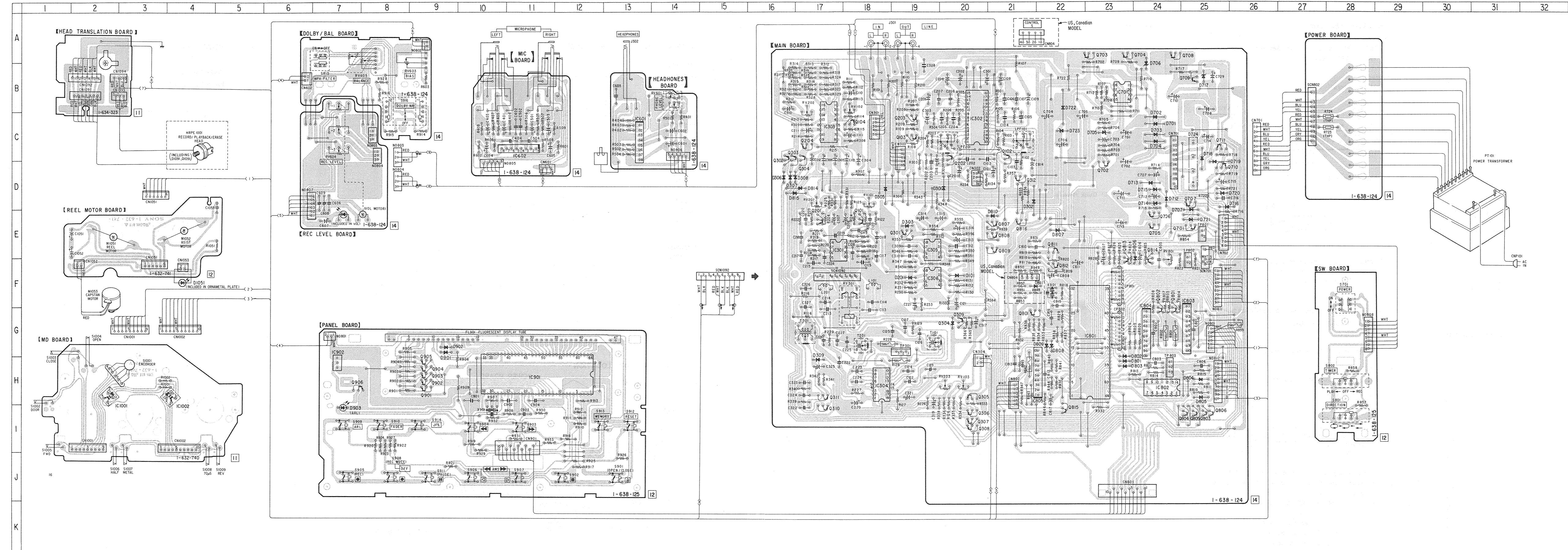

Note on Mounting Diagram:
 • ○ — : parts extracted from the component side.
 • □ — : indicates side identified with part number.

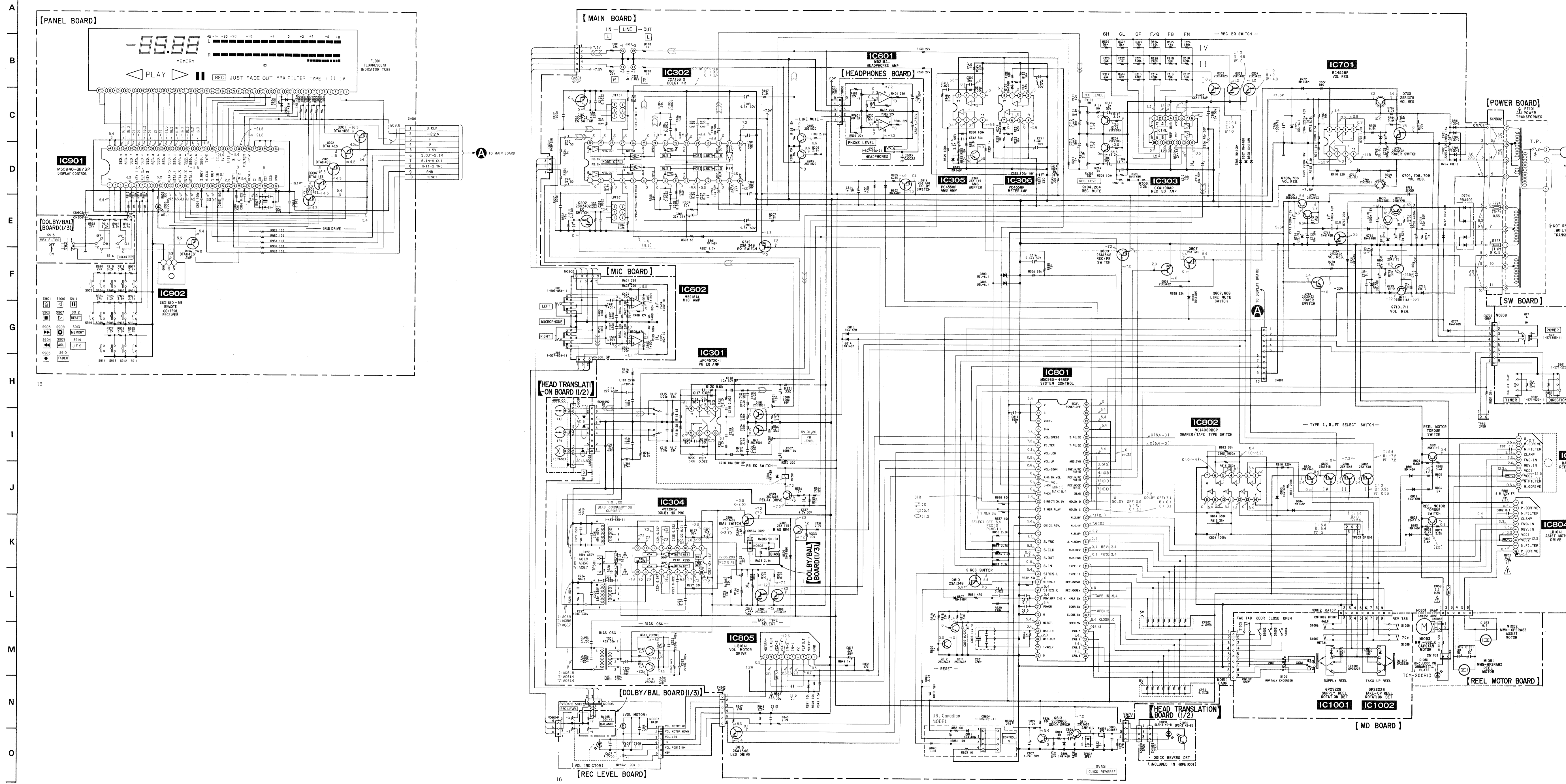

Note on Schematic Diagram :

- All capacitors are in μF unless otherwise noted. pF: μF 50V or less are not indicated except for electrolytics and tantalums.
- All resistors are in Ω and W or less unless otherwise specified.
- W : fusible resistor.

Note : The components identified by mark Δ or dotted line with mark Δ are critical for safety. Replace only with part number specified.

○ : Resistor
 ○ : Line
 ○ : Line
 ○ : adjustment for repair.
 ○ : Voltage and waveforms are dc with respect to ground under no-signal conditions.
 no mark : STOP MODE
 () : PLAY MODE
 < : REC MODE
 [] : DOLBY MODE
 B : DOLBY B MODE
 C : DOLBY C MODE
 ○ : Voltages are taken with a VOM (input impedance 10 M Ω). Voltage variations may be noted due to normal production tolerances.
 ○ : Signal path.
 Σ : PB
 Σ : REC

4-6. BLOCK DIAGRAM

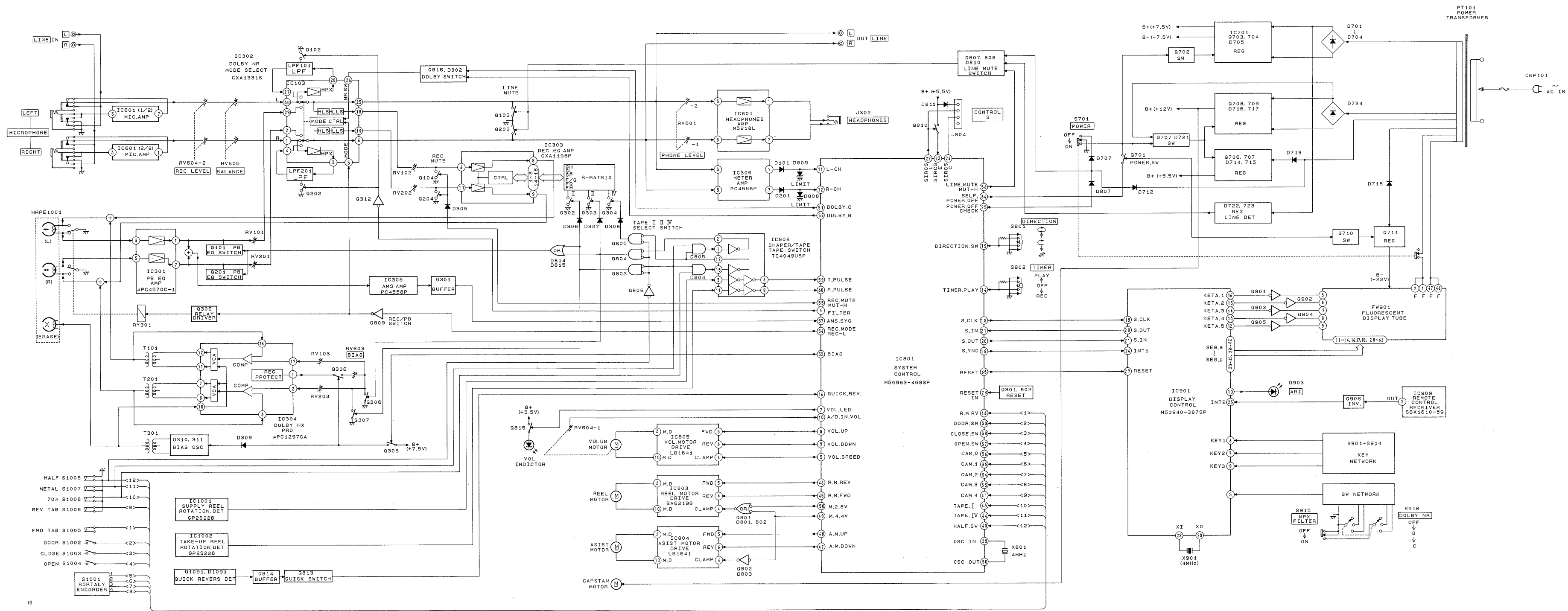

5-2. CHASSIS SECTION

▲A : POWER BOARD

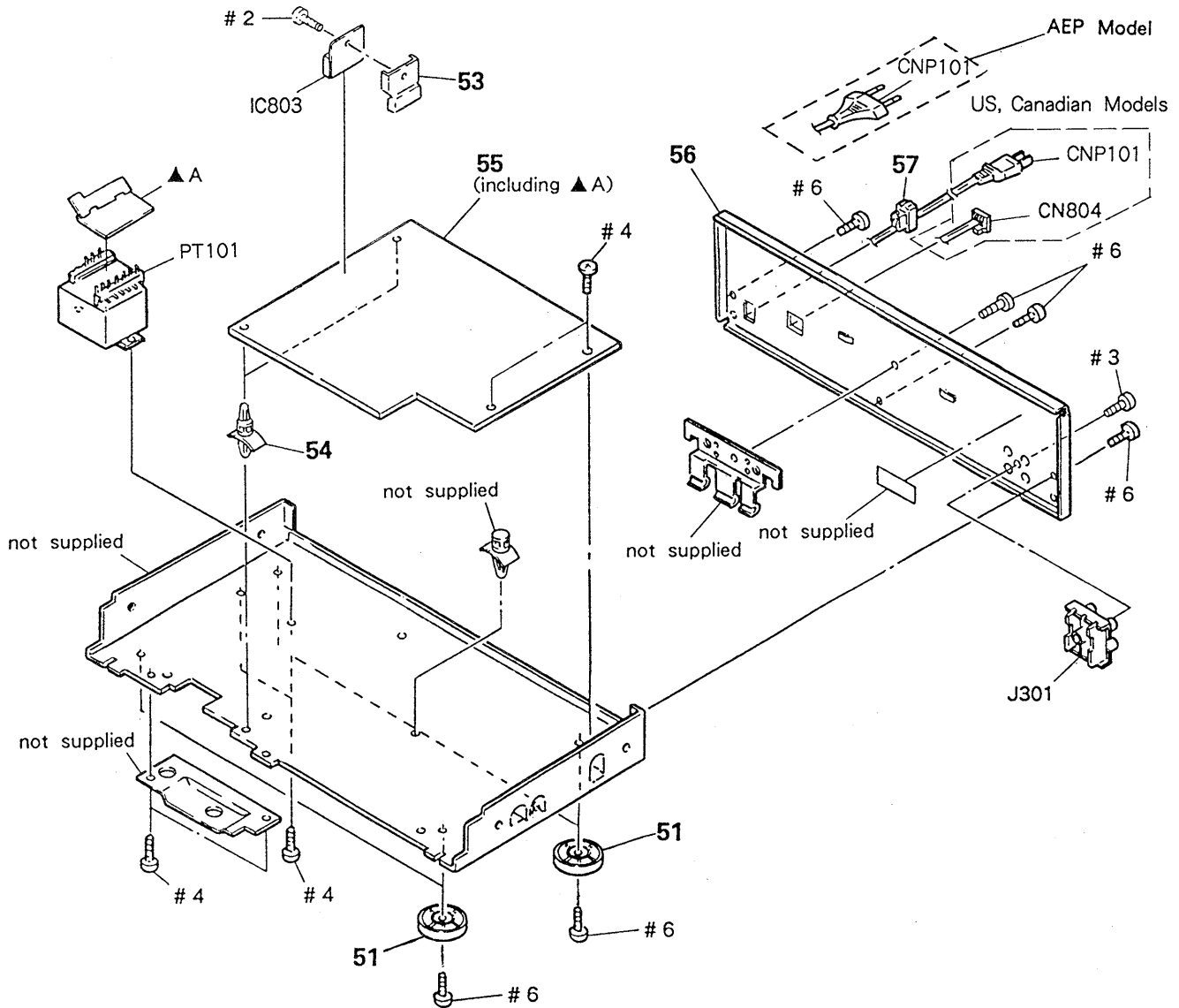

Note:
The components identified by mark ▲ or dotted line with mark ▲ are critical for safety. Replace only with part number specified.

Note:
Les composants identifiés par une marque ▲ sont critiques pour la sécurité. Ne les remplacer que par une pièce portant le numéro spécifié.

Ref. No.	Part No.	Description	Remarks	Ref. No.	Part No.	Description	Remarks
51	4-943-148-42	FOOT		CNP101	▲1-555-795-00	CORD, POWER, EULO PLUG (AEP)	
53	* 3-356-925-01	HEAT SINK		CNP101	▲1-558-945-11	CORD, POWER (POLAR. SPT-1) (US, Canadian)	
54	* 3-346-265-11	HOLDER, PC BOARD		CN804	1-558-350-31	CORD (WITH CONNECTOR) (US, Canadian)	
55	* A-2006-719-A	MAIN BOARD, COMPLETE (AEP)		IC803	8-759-973-95	IC BA6219B	
55	* A-2006-721-A	MAIN BOARD, COMPLETE (US, Canadian)		J301	1-573-070-11	JACK, PIN 4P (LINE) (US, Canadian)	
56	* 3-375-664-11	PANEL, BACK (US, Canadian)		J301	1-565-258-11	JACK, PIN 4P (LINE) (AEP)	
56	* 3-375-664-21	PANEL, BACK (AEP)		PT101	▲1-450-100-11	TRANSFORMER, POWER (US, Canadian)	
56	* 3-375-664-31	PANEL, BACK (AEP)		PT101	▲1-450-399-11	TRANSFORMER, POWER (AEP)	
57	* 3-703-244-00	BUSHING (2104), CORD (AEP)					
57	* 3-703-571-11	BUSHING (S) (4516), CORD (US, Canadian)					

5-3. MECHANISM SECTION (TCM-200R10)

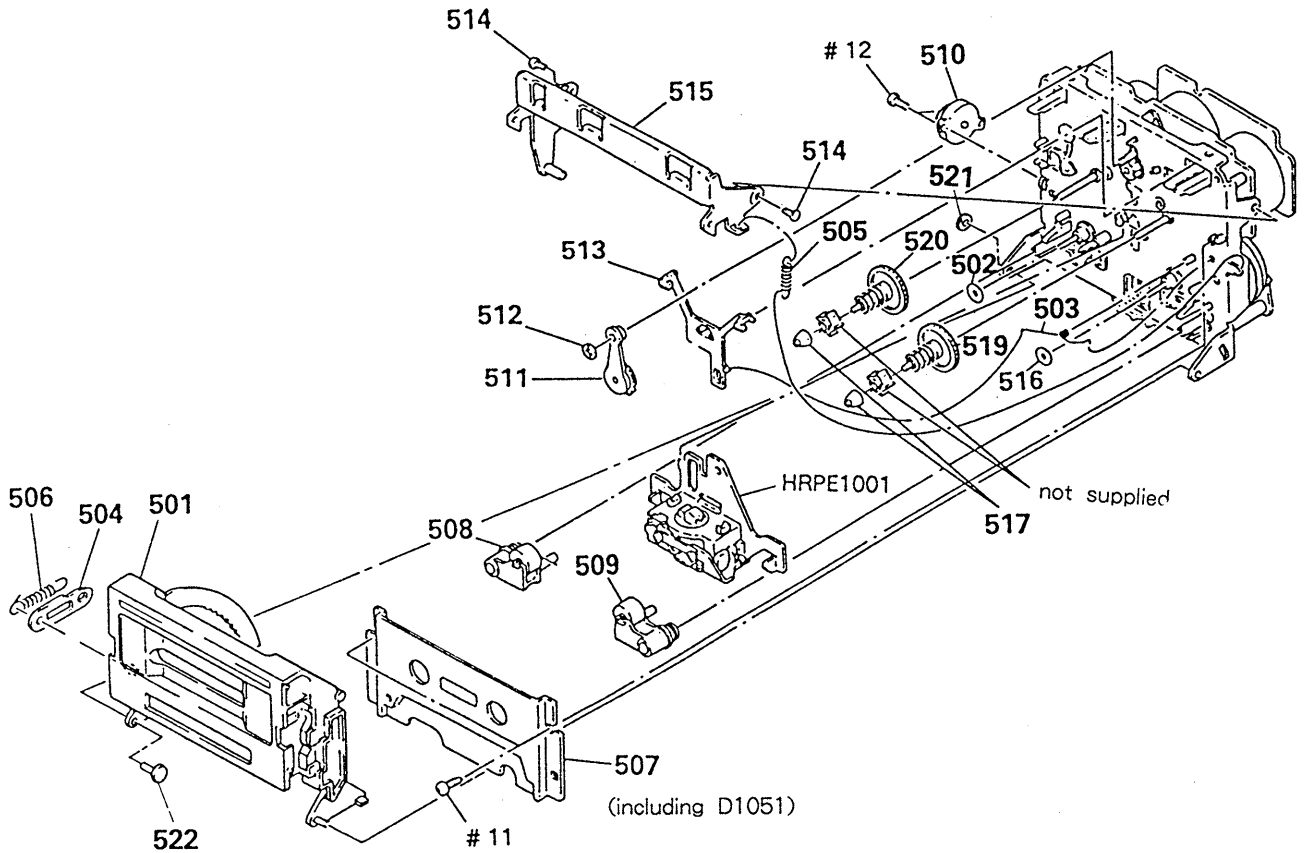

Ref. No.	Part No.	Description	Remarks	Ref. No.	Part No.	Description	Remarks
501	X-3364-799-1	HOLDER (CD) (2) ASSY, CASSETTE		513	3-356-614-01	SLIDER (BRAKE)	
502	3-356-714-01	WASHER		514	3-356-601-11	SCREW, STEP	
503	3-356-619-01	SPRING (B), TORSION		515	* X-3356-608-1	LEVER (LIFTER) ASSY	
504	* 3-356-717-01	LEVER (JOINT)		516	3-356-713-01	WASHER	
505	3-356-625-01	SPRING, TENSION		517	3-362-308-01	CAP (REEL)	
506	3-356-626-01	SPRING, TENSION		519	X-3356-627-1	GEAR (T) ASSY	
507	X-3356-613-1	PLATE ASSY, ORNAMENTAL	(including D1051)	520	X-3356-628-1	GEAR (S) ASSY	
508	X-3343-456-1	LEVER (PINCH R) ASSY		521	3-558-708-21	WASHER, STOPPER	
509	X-3343-455-1	LEVER (PINCH F) ASSY		522	3-378-341-01	SHAFT (L) (CASSETTE HOLDER)	
510	3-712-786-01	DAMPER, OIL		HRPE1001	A-2003-722-A	DECK ASSY, HEAD	
511	X-3356-641-1	LEVER (FR2) ASSY					
512	3-669-465-11	WASHER (1.5), STOPPER					

5-4. MECHANISM SECTION (TCM-200R10)

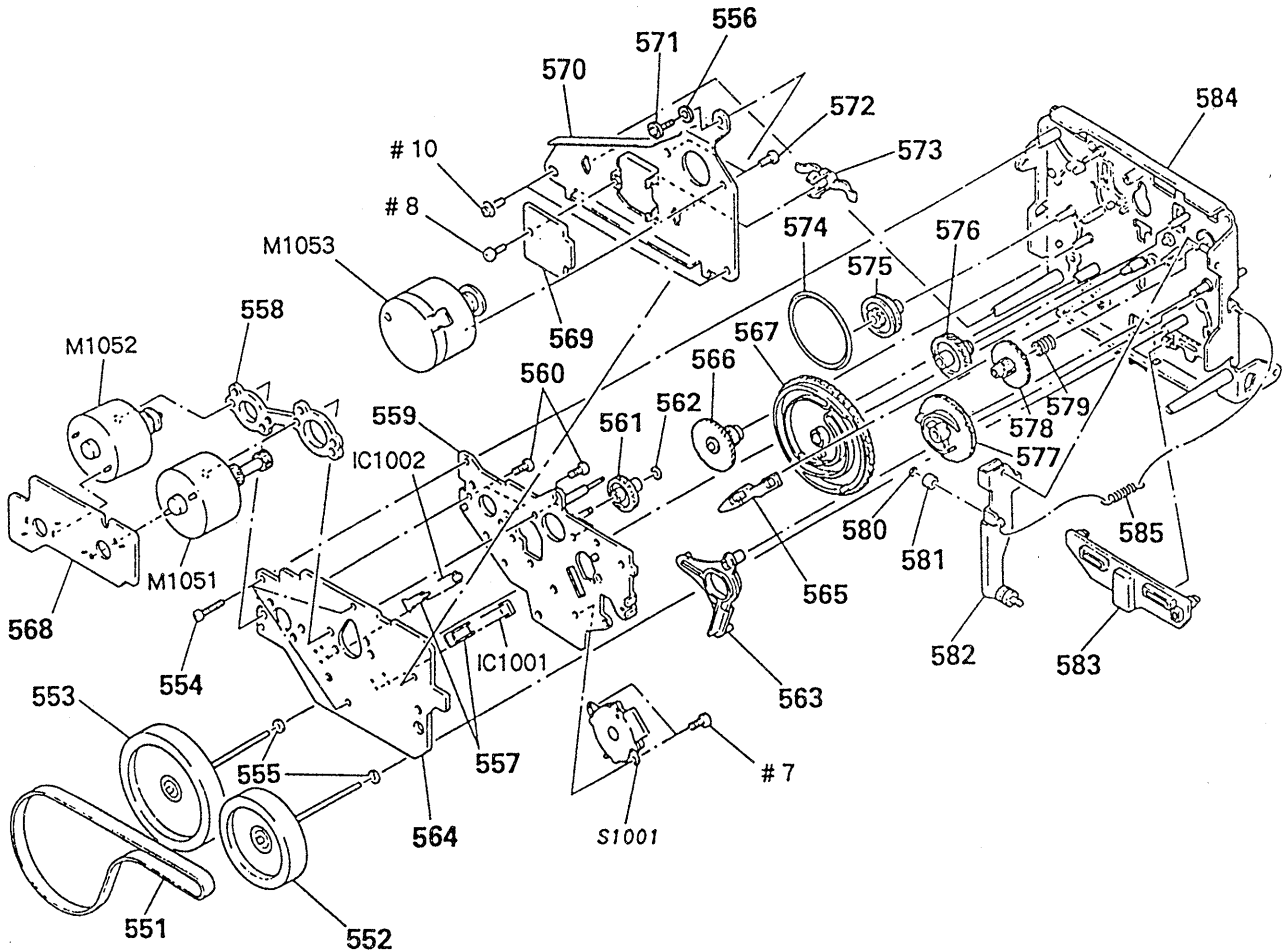

Ref. No.	Part No.	Description	Remarks	Ref. No.	Part No.	Description	Remarks
551	3-356-730-01	BELT (CAPSTAN R2)		572	4-885-599-00	SCREW, FITTING, REINFORCEMENT	
552	X-3356-642-1	FLYWHEEL (R FWD) ASSY		573	3-575-321-00	RETAINER, THRUST, CAPSTAN	
553	X-3356-643-1	FLYWHEEL (R REV) ASSY		574	3-356-603-01	BELT (MODE)	
554	3-355-801-01	SCREW (BTP 2X18)		575	3-356-607-01	PULLEY (MODE)	
555	3-356-705-01	WASHER (CAPSTAN)		576	3-356-703-01	GEAR (COMMUNICATION C)	
556	* 3-356-718-01	SPACER (THRUST RETAINER R)		577	3-356-616-01	GEAR (LOADING CAM)	
557	3-356-631-01	HOLDER (SENSOR)		578	3-356-609-01	GEAR (LOADING)	
558	* 3-356-628-01	SPACER (MOTOR)		579	3-356-605-01	SPRING, COMPRESSION	
559	* X-3356-602-1	BRACKET (MOTOR R) ASSY		580	3-558-708-11	WASHER, STOPPER	
560	3-363-804-01	SCREW (+P 2.6X6.5)		581	3-356-630-01	ROLLER (LOADING)	
561	3-356-702-01	GEAR (COMMUNICATION B)		582	* X-3356-606-1	LEVER (LOADING) ASSY	
562	3-669-465-00	WASHER (1.5), STOPPER		583	3-356-612-01	SLIDER (REVERSE)	
563	3-356-613-01	LEVER (MODE)		584	X-3356-634-1	CHASSIS (R2) COMPLETE ASSY, MECH	
564	* 1-632-740-11	MD BOARD		585	3-376-854-01	SPRING, TENSION	
565	3-356-617-01	LEVER (SELECTION)		IC1001	8-749-920-97	DIODE GP2S22B	
566	3-356-606-01	GEAR (MODE)		IC1002	8-749-920-97	DIODE GP2S22B	
567	3-356-615-01	GEAR (MODE CAM RR)		M1051	X-3356-638-1	MOTOR (REEL R) ASSY	
568	* 1-632-741-11	REEL MOTOR BOARD		M1052	X-3356-604-1	MOTOR (ASSIST) ASSY	
569	* 1-634-323-11	HEAD, TRANSLATION BOARD		M1053	X-3356-646-1	MOTOR (CAPSTAN V1) ASSY	
570	* 3-356-629-01	BRACKET (THRUST RETAINER R)		S1001	1-466-525-11	ENCORDER, ROTARY	
571	3-356-707-01	SCREW (+PTPWH 2X25)					

SECTION 6 ELECTRICAL PARTS LIST

HEAD TRANSLATION

MD MAIN

NOTE :

The components identified by mark Δ or dotted line with mark Δ are critical for safety. Replace only with part number specified.

Les composants identifiés par une marque Δ sont critiques pour la sécurité. Ne les remplacer que par une pièce portant le numéro spécifié.

When indicating parts by reference number, please include the board name.

- Due to standardization, replacements in the parts list may be different from the parts specified in the diagrams or the components used on the set.
- - XX, - X mean standardized parts, so they may have some difference from the original one.
- RESISTORS
All resistors are in ohms.
METAL : metal-film resistor
METAL OXIDE : Metal Oxide-film resistor
F : nonflammable
- Items marked "*" are not stocked since they are seldom required for routine service. Some delay should be anticipated when ordering these items.
- SEMICONDUCTORS
In each case, u : μ , for example :
uA... : μ A..., uPA..., μ PA...,
uPB..., μ PB..., uPC..., μ PC...,
uPD..., μ PD...
- CAPACITORS :
uF : μ F
- COILS

Ref. No.	Part No.	Description	Remarks	Ref. No.	Part No.	Description	Remarks
* 1-634-323-11		HEAD TRANSLATION BOARD *****		* A-2006-721-A		MAIN BOARD, COMPLETE (US, Canadian) *****	
		< CONNECTOR >		* A-2006-719-A		MAIN BOARD, COMPLETE (AEP) *****	(including 1A)
CN1091 * 1-564-709-11		PIN, CONNECTOR (SMALL TYPE) 7P		* 1-690-880-21		READ (WITH CONNECTOR)	
CN1092 * 1-564-509-11		PLUG, CONNECTOR 6P		* 3-356-925-01		HEAT SINK	
CN1093 * 1-564-705-11		PIN, CONNECTOR (SMALL TYPE) 3P		7-682-547-04		SCREW +BVT 3X6 (S)	
CN1094 * 1-564-506-11		PLUG, CONNECTOR 3P				< CAPACITOR >	

* 1-632-740-11		MD BOARD *****		C101	1-124-907-11	ELECT 10uF 20% 50V	
3-356-631-01		HOLDER (SENSOR)		C102	1-162-294-31	CERAMIC 0.001uF 10% 50V	
		< CONNECTOR >		C103	1-161-375-00	CERAMIC 0.0022uF 20% 50V	
CN1001 1-506-615-11		PIN, CONNECTOR 9P		C104	1-130-475-00	MYLAR 0.0022uF 5% 50V	
CN1002 * 1-564-502-11		PIN, CONNECTOR 10P		C105	1-130-475-00	MYLAR 0.0022uF 5% 50V	
		< IC >		C106	1-136-174-00	FILM 0.56uF 5% 50V	
IC1001 8-749-920-97		DIODE GP2S22B		C107	1-136-171-00	FILM 0.33uF 5% 50V	
IC1002 8-749-920-97		DIODE GP2S22B		C108	1-124-907-11	ELECT 10uF 20% 50V	
		< RESISTOR >		C109	1-124-927-11	ELECT 4.7uF 20% 100V	
R1001 1-249-408-11		CARBON 180 5% 1/4W		C110	1-124-902-00	ELECT 0.47uF 20% 50V	
R1002 1-249-408-11		CARBON 180 5% 1/4W		C111	1-124-907-11	ELECT 10uF 20% 50V	
		< SWITCH >		C112	1-124-907-11	ELECT 10uF 20% 50V	
S1001 1-466-237-11		ENCORDER, ROTARY		C113	1-162-285-31	CERAMIC 180PF 10% 50V	
S1002 1-570-953-11		SWITCH, PUSH (1 KEY) (DOOR)		C114	1-136-935-11	FILM 22PF 5% 630V	
S1003 1-571-958-11		SWITCH, PUSH (1 KEY) (CLOSE)		C115	1-164-736-31	CERAMIC 0.0012uF 10% 50V	
S1004 1-572-126-11		SWITCH, PUSH (1 KEY) (OPEN)		C117	1-136-157-00	FILM 0.022uF 5% 50V	
S1005 1-572-125-11		SWITCH, LEAF (FWD TAB)		C118	1-124-657-00	ELECT 10uF 20% 50V	
S1006 1-572-202-11		SWITCH, LEAF (HALF)		C119	1-161-494-00	CERAMIC 0.022uF 25V	
S1007 1-572-125-11		SWITCH, LEAF (METAL)		C120	1-136-158-00	FILM 0.027uF 5% 50V	
S1008 1-572-125-11		SWITCH, LEAF (70uS)		C121	1-123-382-00	ELECT 3.3uF 20% 100V	
S1009 1-572-125-11		SWITCH, LEAF (REV TAB)		C122	1-136-153-00	FILM 0.01uF 5% 50V	
		< TERMINAL >		C123	1-136-157-00	FILM 0.022uF 5% 50V	
TB1001 * 1-694-018-11		TERMINAL (5P)		C124	1-136-161-00	FILM 0.047uF 5% 50V	
		*****		C125	1-136-272-00	FILM 68PF 5% 630V	
				C126	1-130-468-00	MYLAR 560PF 5% 50V	
				C127	1-136-433-11	FILM 100PF 5% 630V	
				C128	1-162-282-31	CERAMIC 100PF 10% 50V	
				C201	1-124-907-11	ELECT 10uF 20% 50V	
				C202	1-162-294-31	CERAMIC 0.001uF 10% 50V	
				C203	1-161-375-00	CERAMIC 0.0022uF 20% 50V	

MAIN

Ref. No.	Part No.	Description	Remarks	Ref. No.	Part No.	Description	Remarks
C204	1-130-475-00	MYLAR	0.0022uF 5% 50V	C404	1-162-282-31	CERAMIC	100PF 10% 50V
C205	1-130-475-00	MYLAR	0.0022uF 5% 50V	C501	1-124-903-11	ELECT	1uF 20% 50V
C206	1-136-174-00	FILM	0.56uF 5% 50V	C502	1-162-292-31	CERAMIC	680PF 10% 50V
C207	1-136-171-00	FILM	0.33uF 5% 50V	C503	1-124-903-11	ELECT	1uF 20% 50V
C208	1-124-907-11	ELECT	10uF 20% 50V	C504	1-162-282-31	CERAMIC	100PF 10% 50V
C209	1-124-927-11	ELECT	4.7uF 20% 100V	C601	1-124-927-11	ELECT	4.7uF 20% 100V
C210	1-124-902-00	ELECT	0.47uF 20% 50V	C602	1-124-927-11	ELECT	4.7uF 20% 100V
C211	1-124-907-11	ELECT	10uF 20% 50V	C603	1-161-375-00	CERAMIC	0.0022uF 20% 50V
C212	1-124-907-11	ELECT	10uF 20% 50V	C604	1-124-443-00	ELECT	100uF 20% 10V
C213	1-162-285-31	CERAMIC	180PF 10% 50V	C605	1-124-443-00	ELECT	100uF 20% 10V
C214	1-136-935-11	FILM	22PF 5% 630V	C606	1-164-159-11	CERAMIC	0.1uF 50V
C215	1-164-736-31	CERAMIC	0.0012uF 10% 50V	C607	1-124-927-11	ELECT	4.7uF 20% 100V
C217	1-136-157-00	FILM	0.022uF 5% 50V	C608	1-164-159-11	CERAMIC	0.1uF 50V
C218	1-124-657-00	ELECT	10uF 20% 50V	C609	1-164-159-11	CERAMIC	0.1uF 50V
C219	1-161-494-00	CERAMIC	0.022uF 25V	C610	1-161-494-00	CERAMIC	0.022uF 25V
C220	1-136-158-00	FILM	0.027uF 5% 50V	C701	1-124-556-11	ELECT	2200uF 20% 16V
C221	1-123-382-00	ELECT	3.3uF 20% 100V	C702	1-124-556-11	ELECT	2200uF 20% 16V
C222	1-136-153-00	FILM	0.01uF 5% 50V	C703	1-124-478-11	ELECT	100uF 20% 25V
C223	1-136-157-00	FILM	0.022uF 5% 50V	C704	1-124-893-11	ELECT	2200uF 20% 10V
C224	1-136-161-00	FILM	0.047uF 5% 50V	C705	1-124-893-11	ELECT	2200uF 20% 10V
C225	1-136-272-00	FILM	68PF 5% 630V	C706	1-124-360-00	ELECT	1000uF 20% 16V
C226	1-130-468-00	MYLAR	560PF 5% 50V	C707	1-124-907-11	ELECT	10uF 20% 50V
C227	1-136-433-11	FILM	100PF 5% 630V	C708	1-124-564-11	ELECT	4700uF 20% 25V
C228	1-162-282-31	CERAMIC	100PF 10% 50V	C709	1-124-907-11	ELECT	10uF 20% 50V
C301	1-124-907-11	ELECT	10uF 20% 50V	C710	1-124-360-00	ELECT	1000uF 20% 16V
C302	1-124-907-11	ELECT	10uF 20% 50V	C711	1-124-887-00	ELECT	3300uF 20% 16V
C303	1-126-233-11	ELECT	22uF 20% 50V	C712	1-124-907-11	ELECT	10uF 20% 50V
C304	1-124-903-11	ELECT	1uF 20% 50V	C713	1-124-473-11	ELECT	1000uF 20% 10V
C305	1-124-907-11	ELECT	10uF 20% 50V	C714	1-124-122-11	ELECT	100uF 20% 50V
C306	1-124-907-11	ELECT	10uF 20% 50V	C715	1-124-910-11	ELECT	47uF 20% 50V
C307	1-124-443-00	ELECT	100uF 20% 10V	C716	1-164-159-11	CERAMIC	0.1uF 50V
C308	1-124-443-00	ELECT	100uF 20% 10V	C801	1-164-159-11	CERAMIC	0.1uF 50V
C309	1-162-217-31	CERAMIC	56PF 5% 50V	C802	1-164-159-11	CERAMIC	0.1uF 50V
C310	1-161-494-00	CERAMIC	0.022uF 25V	C803	1-162-294-31	CERAMIC	0.001uF 10% 50V
C311			0.0033uF	C804	1-162-294-31	CERAMIC	0.001uF 10% 50V
C312	1-162-217-31	CERAMIC	56PF 5% 50V	C805	1-161-377-00	CERAMIC	0.0047uF 30% 16V
C313	1-124-925-11	ELECT	2.2uF 20% 100V	C806	1-124-477-11	ELECT	47uF 20% 25V
C314	1-124-443-00	ELECT	100uF 20% 10V	C807	1-124-927-11	ELECT	4.7uF 20% 100V
C315	1-124-443-00	ELECT	100uF 20% 10V	C808	1-124-907-11	ELECT	10uF 20% 50V
C316	1-124-902-00	ELECT	0.47uF 20% 50V	C809	1-161-494-00	CERAMIC	0.022uF 25V
C317	1-124-927-11	ELECT	4.7uF 20% 100V	C810	1-164-159-11	CERAMIC	0.1uF 50V
C318	1-124-925-11	ELECT	2.2uF 20% 100V	C811	1-124-443-00	ELECT	100uF 20% 10V
C319	1-124-902-00	ELECT	0.47uF 20% 50V	C812	1-164-159-11	CERAMIC	0.1uF 50V
C320	1-124-477-11	ELECT	47uF 20% 25V	C813	1-164-159-11	CERAMIC	0.1uF 50V
C321	1-124-477-11	ELECT	47uF 20% 25V	C814	1-124-903-11	ELECT	1uF 20% 50V
C322	1-136-230-00	FILM	0.0022uF 5% 100V	C815	1-164-159-11	CERAMIC	0.1uF 50V
C323	1-136-230-00	FILM	0.0022uF 5% 100V	C816	1-161-494-00	CERAMIC	0.022uF 25V
C324	1-130-856-00	FILM	0.0068uF 5% 100V	C817	1-126-233-11	ELECT	22uF 20% 50V
C325	1-124-907-11	ELECT	10uF 20% 50V			< CONNECTOR >	
C326	1-136-558-11	FILM	0.0039uF 5% 630V	CN301	* 1-564-339-61	PIN, CONNECTOR	5P
C327	1-107-046-00	MICA	4.7PF 500V	CN302	* 1-564-705-11	PIN, CONNECTOR (SMALL TYPE)	3P
C328	1-161-494-00	CERAMIC	0.022uF 25V	CN303	* 1-564-339-00	PIN, CONNECTOR	5P
C401	1-124-903-11	ELECT	1uF 20% 50V	CN304	* 1-564-336-00	PIN, CONNECTOR	2P
C402	1-162-292-31	CERAMIC	680PF 10% 50V	CN601	* 1-564-705-11	PIN, CONNECTOR (SMALL TYPE)	3P
C403	1-124-903-11	ELECT	1uF 20% 50V				

MAIN

Ref. No.	Part No.	Description	Remarks	Ref. No.	Part No.	Description	Remarks
CN602	* 1-564-336-00	PIN, CONNECTOR 2P		D814	8-719-987-63	DIODE 1N4148M	
CN701	* 1-564-513-11	PLUG, CONNECTOR 10P		D815	8-719-987-63	DIODE 1N4148M	
CN702	* 1-564-342-11	PIN, CONNECTOR 8P				< IC >	
CN801	* 1-580-784-11	CONNECTOR, BOARD TO BOARD		IC301	8-759-111-44	IC uPC4570C-1	
CN802	* 1-564-340-00	PIN, CONNECTOR 6P		IC302	8-752-059-55	IC CXA1331S	
CN804	1-558-350-31	CORD (WITH CONNECTOR) (US, Canadian)		IC303	8-752-060-64	IC CXA1198AP	
		< COMPOSITION CIRCUIT BLOCK >		IC304	8-759-106-56	IC uPC1297CA	
CP801	1-233-204-11	COMPOSITION CIRCUIT BLOCK (4. 7KX8)		IC305	8-759-945-58	IC RC4558P	
CP802	1-233-204-11	COMPOSITION CIRCUIT BLOCK (4. 7KX8)		IC306	8-759-945-58	IC RC4558P	
		< DIODE >		IC601	8-759-634-50	IC M5218AL	
D101	8-719-987-63	DIODE 1N4148M		IC602	8-759-634-50	IC M5218AL	
D201	8-719-987-63	DIODE 1N4148M		IC701	8-759-945-58	IC RC4558P	
D301	8-719-987-63	DIODE 1N4148M		IC801	8-759-060-85	IC M50963-468SP	
D302	8-719-987-63	DIODE 1N4148M		IC802	8-759-240-69	IC TC4069UBP	
D303	8-719-987-63	DIODE 1N4148M		IC803	8-759-973-95	IC BA6219B	
D304	8-719-987-63	DIODE 1N4148M		IC804	8-759-822-09	IC LB1641	
D305	8-719-987-63	DIODE 1N4148M		IC805	8-759-822-09	IC LB1641	
D306	8-719-987-63	DIODE 1N4148M				< JACK >	
D307	8-719-987-63	DIODE 1N4148M		J101	1-507-854-21	JACK, LARGE TYPE (MICROPHONE LEFT)	
D308	8-719-987-63	DIODE 1N4148M				(US, Canadian)	
D309	8-719-987-63	DIODE 1N4148M		J101	1-507-854-00	JACK, PHONE (MICROPHONE LEFT) (AEP)	
D701	8-719-200-77	DIODE 10E2N		J201	1-507-854-00	JACK, PHONE (MICROPHONE RIGHT) (AEP)	
D702	8-719-200-77	DIODE 10E2N		J201	1-507-854-21	JACK, LARGE TYPE (MICROPHONE RIGHT)	
D703	8-719-200-77	DIODE 10E2N				(US, Canadian)	
D704	8-719-200-77	DIODE 10E2N		J301	1-573-070-11	JACK, PIN 4P (LINE) (US, Canadian)	
D705	8-719-933-33	DIODE HZS6A1L		J301	1-565-258-11	JACK, PIN 4P (LINE) (AEP)	
D706	8-719-933-33	DIODE HZS6A1L		J302	1-507-796-71	JACK (HEADPHONES)	
D707	8-719-987-63	DIODE 1N4148M				< COIL >	
D712	8-719-987-63	DIODE 1N4148M		L101	1-410-780-11	INDUCTOR 27mH	
D713	8-719-200-31	DIODE 21DQ05		L201	1-410-780-11	INDUCTOR 27mH	
D714	8-719-000-78	DIODE HZS7A1L		L301		INDUCTOR 33mH	
D715	8-719-987-63	DIODE 1N4148M				< FILTER >	
D716	8-719-987-63	DIODE 1N4148M		LPF101	1-236-475-11	FILTER, LOW PASS	
D717	8-719-001-70	DIODE UZL-12M1		LPF201	1-236-475-11	FILTER, LOW PASS	
D718	8-719-200-77	DIODE 10E2N				< TRANSISTOR >	
D719	8-719-200-77	DIODE 10E2N		Q101	8-729-900-74	TRANSISTOR DTC143TS	
D720	8-719-000-93	DIODE UZL-7H1		Q102	8-729-900-80	TRANSISTOR DTC114ES	
D721	8-719-987-63	DIODE 1N4148M		Q103	8-729-142-25	TRANSISTOR 2SD1020-HFE	
D722	8-719-987-63	DIODE 1N4148M		Q104	8-729-620-05	TRANSISTOR 2SC2603-EF	
D723	8-719-933-33	DIODE HZS6A1L		Q201	8-729-900-74	TRANSISTOR DTC143TS	
D724	8-719-312-09	DIODE RBA-402		Q202	8-729-900-80	TRANSISTOR DTC114ES	
D801	8-719-987-63	DIODE 1N4148M		Q203	8-729-142-25	TRANSISTOR 2SD1020-HFE	
D802	8-719-987-63	DIODE 1N4148M		Q204	8-729-620-05	TRANSISTOR 2SC2603-EF	
D803	8-719-987-63	DIODE 1N4148M		Q301	8-729-119-76	TRANSISTOR 2SA1175-HFE	
D804	8-719-987-63	DIODE 1N4148M		Q302	8-729-900-80	TRANSISTOR DTC114ES	
D805	8-719-987-63	DIODE 1N4148M		Q303	8-729-900-80	TRANSISTOR DTC114ES	
D806	8-719-987-63	DIODE 1N4148M		Q304	8-729-900-80	TRANSISTOR DTC114ES	
D807	8-719-987-63	DIODE 1N4148M		Q305	8-729-119-76	TRANSISTOR 2SA1175-HFE	
D808	8-719-933-33	DIODE HZS6A1L		Q306	8-729-900-80	TRANSISTOR DTC114ES	
D809	8-719-933-33	DIODE HZS6A1L		Q307	8-729-900-80	TRANSISTOR DTC114ES	
D810	8-719-987-63	DIODE 1N4148M					
D811	8-719-987-63	DIODE 1N4148M (US, Canadian)					

MAIN

Ref. No.	Part No.	Description	Remarks	Ref. No.	Part No.	Description	Remarks
Q308	8-729-900-80	TRANSISTOR DTC114ES		R121	1-249-421-11	CARBON 2.2K 5%	1/4W
Q309	8-729-620-05	TRANSISTOR 2SC2603-EF		R122	1-249-421-11	CARBON 2.2K 5%	1/4W
Q310	8-729-194-57	TRANSISTOR 2SC945-P		R123	1-247-840-00	CARBON 2.4K 5%	1/4W
Q311	8-729-194-57	TRANSISTOR 2SC945-P		R124	1-247-887-00	CARBON 220K 5%	1/4W
Q312	8-729-900-61	TRANSISTOR DTA114ES		R125	1-249-421-11	CARBON 2.2K 5%	1/4W
Q701	8-729-900-80	TRANSISTOR DTC114ES		R126	1-247-858-11	CARBON 13K 5%	1/4W
Q702	8-729-900-80	TRANSISTOR DTC114ES		R127	1-249-435-11	CARBON 33K 5%	1/4W
Q703	8-729-141-83	TRANSISTOR 2SB1094-LK		R128	△ 1-219-153-11	FUSIBLE 10 5%	1/4W F
Q704	8-729-209-15	TRANSISTOR 2SD2012		R129	1-247-883-00	CARBON 150K 5%	1/4W
Q705	8-729-209-15	TRANSISTOR 2SD2012		R130	1-249-434-11	CARBON 27K 5%	1/4W
Q706	8-729-620-05	TRANSISTOR 2SC2603-EF		R131	1-247-870-11	CARBON 43K 5%	1/4W
Q707	8-729-900-80	TRANSISTOR DTC114ES		R132	1-247-868-11	CARBON 36K 5%	1/4W
Q708	8-729-141-83	TRANSISTOR 2SB1094-LK		R133	1-249-408-11	CARBON 180 5%	1/4W
Q709	8-729-620-05	TRANSISTOR 2SC2603-EF		R134	1-249-417-11	CARBON 1K 5%	1/4W
Q710	8-729-119-76	TRANSISTOR 2SA1175-HFE		R201	1-249-433-11	CARBON 22K 5%	1/4W
Q711	8-729-140-04	TRANSISTOR 2SB1116A-L		R202	1-247-887-00	CARBON 220K 5%	1/4W
Q801	8-729-119-76	TRANSISTOR 2SA1175-HFE		R203	1-249-423-11	CARBON 3.3K 5%	1/4W
Q802	8-729-119-76	TRANSISTOR 2SA1175-HFE		R204	1-249-428-11	CARBON 8.2K 5%	1/4W
Q803	8-729-900-61	TRANSISTOR DTA114ES		R205	1-247-864-11	CARBON 24K 5%	1/4W
Q804	8-729-900-61	TRANSISTOR DTA114ES		R206	1-249-414-11	CARBON 560 5%	1/4W
Q805	8-729-900-61	TRANSISTOR DTA114ES		R207	1-249-421-11	CARBON 2.2K 5%	1/4W
Q806	8-729-900-61	TRANSISTOR DTA114ES		R208	1-249-431-11	CARBON 15K 5%	1/4W
Q807	8-729-900-65	TRANSISTOR DTA114ES		R209	1-249-421-11	CARBON 2.2K 5%	1/4W
Q808	8-729-900-80	TRANSISTOR DTC114ES		R210	1-249-417-11	CARBON 1K 5%	1/4W
Q809	8-729-900-61	TRANSISTOR DTA114ES		R211	1-249-429-11	CARBON 10K 5%	1/4W
Q810	8-729-900-61	TRANSISTOR DTA114ES		R212	1-249-424-11	CARBON 3.9K 5%	1/4W
Q811	8-729-620-05	TRANSISTOR 2SC2603-EF		R213	1-249-421-11	CARBON 2.2K 5%	1/4W
Q812	8-729-620-05	TRANSISTOR 2SC2603-EF		R214	1-249-429-11	CARBON 10K 5%	1/4W
Q813	8-729-620-05	TRANSISTOR 2SC2603-EF		R215	1-249-421-11	CARBON 2.2K 5%	1/4W
Q814	8-729-620-05	TRANSISTOR 2SC2603-EF		R216	1-249-428-11	CARBON 8.2K 5%	1/4W
Q815	8-729-900-61	TRANSISTOR DTA114ES		R217	1-249-435-11	CARBON 33K 5%	1/4W
Q816	8-729-900-61	TRANSISTOR DTA114ES		R218	1-249-403-11	CARBON 68 5%	1/4W
		< RESISTOR >		R219	1-247-882-11	CARBON 130K 5%	1/4W
R101	1-249-433-11	CARBON 22K 5%	1/4W	R220	1-249-426-11	CARBON 5.6K 5%	1/4W
R102	1-247-887-00	CARBON 220K 5%	1/4W	R221	1-249-421-11	CARBON 2.2K 5%	1/4W
R103	1-249-423-11	CARBON 3.3K 5%	1/4W	R222	1-249-421-11	CARBON 2.2K 5%	1/4W
R104	1-249-428-11	CARBON 8.2K 5%	1/4W	R223	1-247-840-00	CARBON 2.4K 5%	1/4W
R105	1-247-864-11	CARBON 24K 5%	1/4W	R224	1-247-887-00	CARBON 220K 5%	1/4W
R106	1-249-414-11	CARBON 560 5%	1/4W	R225	1-249-421-11	CARBON 2.2K 5%	1/4W
R107	1-249-421-11	CARBON 2.2K 5%	1/4W	R226	1-247-858-11	CARBON 13K 5%	1/4W
R108	1-249-431-11	CARBON 15K 5%	1/4W	R227	1-249-435-11	CARBON 33K 5%	1/4W
R109	1-249-421-11	CARBON 2.2K 5%	1/4W	R228	△ 1-219-153-11	FUSIBLE 10 5%	1/4W F
R110	1-249-417-11	CARBON 1K 5%	1/4W	R229	1-247-883-00	CARBON 150K 5%	1/4W
R111	1-249-429-11	CARBON 10K 5%	1/4W	R230	1-249-434-11	CARBON 27K 5%	1/4W
R112	1-249-424-11	CARBON 3.9K 5%	1/4W	R231	1-247-870-11	CARBON 43K 5%	1/4W
R113	1-249-421-11	CARBON 2.2K 5%	1/4W	R232	1-247-868-11	CARBON 36K 5%	1/4W
R114	1-249-429-11	CARBON 10K 5%	1/4W	R233	1-249-408-11	CARBON 180 5%	1/4W
R115	1-249-421-11	CARBON 2.2K 5%	1/4W	R234	1-249-417-11	CARBON 1K 5%	1/4W
R116	1-249-428-11	CARBON 8.2K 5%	1/4W	R301	1-249-417-11	CARBON 1K 5%	1/4W
R117	1-249-435-11	CARBON 33K 5%	1/4W	R302	1-249-437-11	CARBON 47K 5%	1/4W
R118	1-249-403-11	CARBON 68 5%	1/4W	R303	1-249-403-11	CARBON 68 5%	1/4W
R119	1-247-882-11	CARBON 130K 5%	1/4W	R304	1-249-429-11	CARBON 10K 5%	1/4W
R120	1-249-426-11	CARBON 5.6K 5%	1/4W	R305	1-215-455-00	METAL 27K 1%	1/6W
				R306	1-249-421-11	CARBON 2.2K 5%	1/4W
				R307	1-249-417-11	CARBON 1K 5%	1/4W

<p>Note: The components identified by mark △ or dotted line with mark △ are critical for safety. Replace only with part number specified.</p>	<p>Note: Les composants identifiés par une marque △ sont critiques pour la sécurité. Ne les remplacer que par une pièce portant le numéro spécifié.</p>
--	--

MAIN

Ref. No.	Part No.	Description	Remarks	Ref. No.	Part No.	Description	Remarks
R308	1-249-441-11	CARBON	100K 5% 1/4W	R406	1-249-429-11	CARBON	10K 5% 1/4W
R309	1-247-864-11	CARBON	24K 5% 1/4W	R407	1-249-411-11	CARBON	330 5% 1/4W
R312	1-249-438-11	CARBON	56K 5% 1/4W	R408	1-249-437-11	CARBON	47K 5% 1/4W
R313	1-249-436-11	CARBON	39K 5% 1/4W	R409	1-249-441-11	CARBON	100K 5% 1/4W
R314	1-247-885-00	CARBON	180K 5% 1/4W	R501	1-249-433-11	CARBON	22K 5% 1/4W
R315	1-247-882-11	CARBON	130K 5% 1/4W	R502	1-249-421-11	CARBON	2. 2K 5% 1/4W
R316	1-249-436-11	CARBON	39K 5% 1/4W	R503	1-249-433-11	CARBON	22K 5% 1/4W
R317	1-247-870-11	CARBON	43K 5% 1/4W	R504	1-249-409-11	CARBON	220 5% 1/4W
R318	1-247-893-11	CARBON	390K 5% 1/4W	R505	1-249-441-11	CARBON	100K 5% 1/4W
R319	1-247-866-11	CARBON	30K 5% 1/4W	R506	1-249-429-11	CARBON	10K 5% 1/4W
R320	1-247-888-11	CARBON	240K 5% 1/4W	R507	1-249-411-11	CARBON	330 5% 1/4W
R321	1-247-890-11	CARBON	300K 5% 1/4W	R508	1-249-437-11	CARBON	47K 5% 1/4W
R322	1-247-872-11	CARBON	51K 5% 1/4W	R509	1-249-441-11	CARBON	100K 5% 1/4W
R323	1-249-438-11	CARBON	56K 5% 1/4W	R601	1-249-409-11	CARBON	220 5% 1/4W
R324	1-247-885-00	CARBON	180K 5% 1/4W	R602	1-249-409-11	CARBON	220 5% 1/4W
R325	1-247-870-11	CARBON	43K 5% 1/4W	R603	1-247-840-00	CARBON	2. 4K 5% 1/4W
R326	1-247-880-11	CARBON	110K 5% 1/4W	R605	1-247-727-11	CARBON	10 5% 1/2W
R327	1-247-876-11	CARBON	75K 5% 1/4W	R701	1-249-433-11	CARBON	22K 5% 1/4W
R328	1-249-438-11	CARBON	56K 5% 1/4W	R702	1-249-425-11	CARBON	4. 7K 5% 1/4W
R329	1-249-438-11	CARBON	56K 5% 1/4W	R703	1-249-420-11	CARBON	1. 8K 5% 1/4W
R330	1-249-409-11	CARBON	220 5% 1/4W	R704	1-249-426-11	CARBON	5. 6K 5% 1/4W
R331	1-249-409-11	CARBON	220 5% 1/4W	R705	1-249-427-11	CARBON	6. 8K 5% 1/4W
R332	1-249-422-11	CARBON	2. 7K 5% 1/4W	R706	1-249-419-11	CARBON	1. 5K 5% 1/4W
R333	1-249-429-11	CARBON	10K 5% 1/4W	R707	1-249-429-11	CARBON	10K 5% 1/4W
R334	1-247-836-11	CARBON	1. 6K 5% 1/4W	R708	1-249-419-11	CARBON	1. 5K 5% 1/4W
R335	1-249-422-11	CARBON	2. 7K 5% 1/4W	R709	1-249-425-11	CARBON	4. 7K 5% 1/4W
R336	1-249-428-11	CARBON	8. 2K 5% 1/4W	R710	1-249-409-11	CARBON	220 5% 1/4W
R338	1-249-441-11	CARBON	100K 5% 1/4W	R711	1-249-417-11	CARBON	1K 5% 1/4W
R339	1-249-437-11	CARBON	47K 5% 1/4W	R712	1-249-427-11	CARBON	6. 8K 5% 1/4W
R340	1-249-437-11	CARBON	47K 5% 1/4W	R713	1-249-427-11	CARBON	6. 8K 5% 1/4W
R341	1-249-389-11	CARBON	4. 7 5% 1/4W	R714	1-249-417-11	CARBON	1K 5% 1/4W
R342	1-249-389-11	CARBON	4. 7 5% 1/4W	R715	1-249-425-11	CARBON	4. 7K 5% 1/4W
R343	1-249-409-11	CARBON	220 5% 1/4W	R716	1-249-433-11	CARBON	22K 5% 1/4W
R344	1-249-409-11	CARBON	220 5% 1/4W	R717	1-249-425-11	CARBON	4. 7K 5% 1/4W
R345	1-249-441-11	CARBON	100K 5% 1/4W	R718	1-249-433-11	CARBON	22K 5% 1/4W
R346	1-249-441-11	CARBON	100K 5% 1/4W	R719	1-249-436-11	CARBON	39K 5% 1/4W
R347	1-249-429-11	CARBON	10K 5% 1/4W	R720	1-247-856-00	CARBON	11K 5% 1/4W
R348	1-249-428-11	CARBON	8. 2K 5% 1/4W	R721	1-249-437-11	CARBON	47K 5% 1/4W
R349	1-249-441-11	CARBON	100K 5% 1/4W	R722	1-247-742-11	CARBON	180 5% 1/2W
R350	1-249-441-11	CARBON	100K 5% 1/4W	R723	1-219-135-11	FUSIBLE	0. 15 10% 1/4W
R351	1-249-423-11	CARBON	3. 3K 5% 1/4W	R724	1-219-137-11	FUSIBLE	0. 33 10% 1/4W
R352	1-249-429-11	CARBON	10K 5% 1/4W	R801	△ 1-212-954-11	FUSIBLE	6. 8 5% 1/2W F
R353	1-249-429-11	CARBON	10K 5% 1/4W	R802	△ 1-212-952-00	FUSIBLE	5. 6 5% 1/2W F
R354	1-249-417-11	CARBON	1K 5% 1/4W	R803	1-249-426-11	CARBON	5. 6K 5% 1/4W
R355	1-249-430-11	CARBON	12K 5% 1/4W	R804	1-249-426-11	CARBON	5. 6K 5% 1/4W
R356	1-249-435-11	CARBON	33K 5% 1/4W	R805	1-249-417-11	CARBON	1K 5% 1/4W
R357	1-249-425-11	CARBON	4. 7K 5% 1/4W	R806	1-247-838-00	CARBON	2K 5% 1/4W
R364	1-249-421-11	CARBON	2. 2K 5% 1/4W	R807	1-249-426-11	CARBON	5. 6K 5% 1/4W
R365	1-249-431-11	CARBON	15K 5% 1/4W	R808	1-249-428-11	CARBON	8. 2K 5% 1/4W
R366	1-249-429-11	CARBON	10K 5% 1/4W	R809	1-249-423-11	CARBON	3. 3K 5% 1/4W
R401	1-249-433-11	CARBON	22K 5% 1/4W	R810	1-247-887-00	CARBON	220K 5% 1/4W
R402	1-249-421-11	CARBON	2. 2K 5% 1/4W	R811	1-247-887-00	CARBON	220K 5% 1/4W
R403	1-249-433-11	CARBON	22K 5% 1/4W	R812	1-249-436-11	CARBON	39K 5% 1/4W
R404	1-249-409-11	CARBON	220 5% 1/4W	R813	1-247-891-00	CARBON	330K 5% 1/4W
R405	1-249-441-11	CARBON	100K 5% 1/4W	R814	1-247-891-00	CARBON	330K 5% 1/4W

Note:
The components identified by mark Δ or dotted line with mark Δ are critical for safety. Replace only with part number specified.

Note:
Les composants identifiés par une marque Δ sont critiques pour la sécurité. Ne les remplacer que par une pièce portant le numéro spécifié.

MAIN **PANEL**

Ref. No.	Part No.	Description	Remarks	Ref. No.	Part No.	Description	Remarks
R815	1-249-436-11	CARBON	39K 5% 1/4W	RV202	1-238-016-11	RES, ADJ, CARBON 10K	
R816	1-247-903-00	CARBON	1M 5% 1/4W	RV203	1-238-601-11	RES, ADJ, CARBON 22K	
R817	1-249-435-11	CARBON	33K 5% 1/4W	RV601	1-238-085-11	REA, VAR, CARBON 20K/20K (PHONE LEVEL)	
R818	1-249-435-11	CARBON	33K 5% 1/4W	RV603	1-241-046-11	RES, VAR, CARBON 5K (BIAS)	
R819	1-249-425-11	CARBON	4.7K 5% 1/4W	RV604	1-241-410-11	RES, VAR, CARBON 20K/50K/50K (REC LEVEL)	
R820	1-249-417-11	CARBON	1K 5% 1/4W	RV605	1-238-904-11	RES, VAR, CARBON 50K/50K (BALANCE)	
R821	1-249-413-11	CARBON	470 5% 1/4W	RV801	1-238-602-11	RES, ADJ, CARBON 47K	
R822	1-249-417-11	CARBON	1K 5% 1/4W			< RELAY >	
R823	1-249-429-11	CARBON	10K 5% 1/4W	RY301	1-515-683-11	RELAY	
R824	1-249-429-11	CARBON	10K 5% 1/4W			< SWITCH >	
R825	1-249-433-11	CARBON	22K 5% 1/4W	S915	1-554-118-00	SWITCH, PUSH (1 KEY) (MPX FILTER)	
R826	1-249-429-11	CARBON	10K 5% 1/4W	S916	1-572-154-11	SWITCH, ROTARY (DOLBY NR)	
R827	1-249-421-11	CARBON	2.2K 5% 1/4W			< TRANSFORMER >	
R828	1-249-410-11	CARBON	270 5% 1/4W	T101	1-433-335-11	TRANSFORMER, BIAS OSCILLATION	
R829	1-247-887-00	CARBON	220K 5% 1/4W	T201	1-433-335-11	TRANSFORMER, BIAS OSCILLATION	
R830	1-249-413-11	CARBON	470 5% 1/4W	T301	1-433-336-11	TRANSFORMER, BIAS OSCILLATION	
R831	1-249-413-11	CARBON	470 5% 1/4W			< TEST PIN >	
R832	1-249-435-11	CARBON	33K 5% 1/4W	TP301	* 1-564-506-11	PLUG, CONNECTOR 3P	
R833	1-249-421-11	CARBON	2.2K 5% 1/4W	TP801	* 1-564-505-11	PLUG, CONNECTOR 2P	
R834	1-249-421-11	CARBON	2.2K 5% 1/4W	TP802	* 1-564-505-11	PLUG, CONNECTOR 2P	
R835	1-249-421-11	CARBON	2.2K 5% 1/4W	TP803	* 1-564-506-11	PLUG, CONNECTOR 3P	
R836	1-249-421-11	CARBON	2.2K 5% 1/4W			< VIBRATOR >	
R837	1-249-429-11	CARBON	10K 5% 1/4W	X801	1-577-358-21	VIBRATOR, CERAMIC 4MHz	
R838	1-249-429-11	CARBON	10K 5% 1/4W			*****	
R839	1-249-433-11	CARBON	22K 5% 1/4W			* A-2006-722-A	PANEL BOARD, COMPLETE (US, Canadian) *****
R840	1-249-429-11	CARBON	10K 5% 1/4W			* A-2006-720-A	PANEL BOARD, COMPLETE (AEP) ***** (including ■A-F)
R841	1-249-429-11	CARBON	10K 5% 1/4W			9-911-844-XX	CUSHION
R842	△ 1-212-958-00	FUSIBLE	10 5% 1/2W F			* 4-932-502-01	HOLDER, FL TUBE
R843	1-249-419-11	CARBON	1.5K 5% 1/4W			* 4-937-336-01	HOLDER, LED
R844	1-249-417-11	CARBON	1K 5% 1/4W				< CAPACITOR >
R845	1-249-421-11	CARBON	2.2K 5% 1/4W	C901	1-161-494-00	CERAMIC	0.022uF 25V
R846	1-247-887-00	CARBON	220K 5% 1/4W	C902	1-161-494-00	CERAMIC	0.022uF 25V
R847	1-249-410-11	CARBON	270 5% 1/4W	C903	1-162-282-31	CERAMIC	100PF 10% 50V
R848	1-249-421-11	CARBON	2.2K 5% 1/4W (US, Canadian)	C904	1-162-282-31	CERAMIC	100PF 10% 50V
R849	1-249-421-11	CARBON	2.2K 5% 1/4W (US, Canadian)			< CONNECTOR >	
R850	1-249-432-11	CARBON	18K 5% 1/4W	CN901	* 1-580-782-11	CONNECTOR, BOARD TO BOARD 10P	
R851	1-249-429-11	CARBON	10K 5% 1/4W (US, Canadian)			< DIODE >	
R852	1-249-405-11	CARBON	100 5% 1/4W (US, Canadian)	D901	8-719-987-63	DIODE	1N4148M
R853	1-249-393-11	CARBON	10 5% 1/4W (US, Canadian)	D902	8-719-987-63	DIODE	1N4148M
R854	1-247-872-11	CARBON	51K 5% 1/4W	D903	8-719-301-38	DIODE	SEL2210S-C (ARL)
R855	1-249-427-11	CARBON	6.8K 5% 1/4W				
R856	1-249-433-11	CARBON	22K 5% 1/4W				
R859	△ 1-212-942-00	FUSIBLE	2.2 5% 1/2W F				
R914	1-249-422-11	CARBON	2.7K 5% 1/4W				
R915	1-249-424-11	CARBON	3.9K 5% 1/4W				
R916	1-249-428-11	CARBON	8.2K 5% 1/4W				
R928	1-249-434-11	CARBON	27K 5% 1/4W				
		< VARIABLE RESISTOR >					
RV101	1-238-600-11	RES, ADJ, CARBON 10K					
RV102	1-238-016-11	RES, ADJ, CARBON 10K					
RV103	1-238-601-11	RES, ADJ, CARBON 22K					
RV201	1-238-600-11	RES, ADJ, CARBON 10K					

<p>Note: The components identified by mark △ or dotted line with mark △ are critical for safety. Replace only with part number specified.</p>	<p>Note: Les composants identifiés par une marque △ sont critiques pour la sécurité. Ne les remplacer que par une pièce portant le numéro spécifié.</p>
--	--

PANEL REEL

Ref. No.	Part No.	Description	Remarks
		< FILTER >	
FL901	1-519-722-11	INDICATOR TUBE, FLUORESCENT	
		< IC >	
IC901	8-759-060-86	IC M50940-387SP	
IC902	8-741-100-48	IC SBX1610-59	
		< TRANSISTOR >	
Q901	8-729-900-61	TRANSISTOR DTA114ES	
Q902	8-729-900-61	TRANSISTOR DTA114ES	
Q903	8-729-900-61	TRANSISTOR DTA114ES	
Q904	8-729-900-61	TRANSISTOR DTA114ES	
Q905	8-729-900-61	TRANSISTOR DTA114ES	
Q906	8-729-900-65	TRANSISTOR DTA144ES	
		< RESISTOR >	
R857	1-249-422-11	CARBON 2.7K 5% 1/4W	
R858	1-249-422-11	CARBON 2.7K 5% 1/4W	
R901	1-249-441-11	CARBON 100K 5% 1/4W	
R902	1-249-441-11	CARBON 100K 5% 1/4W	
R903	1-249-441-11	CARBON 100K 5% 1/4W	
R904	1-249-441-11	CARBON 100K 5% 1/4W	
R905	1-249-441-11	CARBON 100K 5% 1/4W	
R906	1-249-441-11	CARBON 100K 5% 1/4W	
R907	1-247-903-00	CARBON 1M 5% 1/4W	
R908	1-249-435-11	CARBON 33K 5% 1/4W	
R909	1-249-411-11	CARBON 330 5% 1/4W	
R910	1-249-429-11	CARBON 10K 5% 1/4W	
R911	1-249-429-11	CARBON 10K 5% 1/4W	
R912	1-249-429-11	CARBON 10K 5% 1/4W	
R913	1-249-429-11	CARBON 10K 5% 1/4W	
R917	1-249-422-11	CARBON 2.7K 5% 1/4W	
R918	1-249-424-11	CARBON 3.9K 5% 1/4W	
R919	1-249-428-11	CARBON 8.2K 5% 1/4W	
R920	1-249-434-11	CARBON 27K 5% 1/4W	
R921	1-249-422-11	CARBON 2.7K 5% 1/4W	
R922	1-249-424-11	CARBON 3.9K 5% 1/4W	
R923	1-249-428-11	CARBON 8.2K 5% 1/4W	
R924	1-249-434-11	CARBON 27K 5% 1/4W	
R925	1-249-422-11	CARBON 2.7K 5% 1/4W	
R926	1-249-424-11	CARBON 3.9K 5% 1/4W	
R927	1-249-428-11	CARBON 8.2K 5% 1/4W	
R929	1-249-405-11	CARBON 100 5% 1/4W	
R930	1-249-405-11	CARBON 100 5% 1/4W	
R931	1-249-405-11	CARBON 100 5% 1/4W	
R932	1-249-405-11	CARBON 100 5% 1/4W	
R933	1-249-405-11	CARBON 100 5% 1/4W	
		< SWITCH >	
S701	1-554-118-00	SWITCH, PUSH (1 KEY)(POWER)	
S801	1-571-520-11	SWITCH, SLIDE (DIRECTION)	
S802	1-571-520-11	SWITCH, SLIDE (TIMER)	
S901	1-554-303-21	SWITCH, TACTILE (OPEN/CLOSE ▲)	

Ref. No.	Part No.	Description	Remarks
S902	1-554-303-21	SWITCH, TACTILE (■)	
S903	1-554-303-21	SWITCH, TACTILE (▶▶)	
S904	1-554-303-21	SWITCH, TACTILE (◀◀)	
S905	1-554-303-21	SWITCH, TACTILE (REC ●)	
S906	1-554-303-21	SWITCH, TACTILE (<)	
S907	1-554-303-21	SWITCH, TACTILE (>)	
S908	1-554-303-21	SWITCH, TACTILE (REC MUTE ○)	
S909	1-554-303-21	SWITCH, TACTILE (ARL)	
S910	1-554-303-21	SWITCH, TACTILE (FADER)	
S911	1-554-303-21	SWITCH, TACTILE (PAUSE ■■)	
S912	1-554-303-21	SWITCH, TACTILE (RESET)	
S913	1-554-303-21	SWITCH, TACTILE (MEMORY)	
S914	1-554-303-21	SWITCH, TACTILE (JFS)	
		< VIBRATOR >	
X901	1-577-358-21	VIBRATOR, CERAMIC 4MHz	

	* 1-632-741-11	REEL MOTOR BOARD	

		< CAPACITOR >	
C1051	1-124-907-11	ELECT 10uF 20% 50V	
C1052	1-124-907-11	ELECT 10uF 20% 50V	
C1053	1-164-159-11	CERAMIC 0.1uF 50V	
		< CONNECTOR >	
CN1051	* 1-564-499-11	PIN, CONNECTOR 6P	
CN1052	* 1-564-718-11	PIN, CONNECTOR (SMALL TYPE) 2P	
CN1053	* 1-564-718-11	PIN, CONNECTOR (SMALL TYPE) 2P	
		< RESISTOR >	
R1051	1-249-414-11	CARBON 560 5% 1/4W	
		< MOTOR >	
M1051	X-3356-638-1	MOTOR (REEL) ASSY	
M1052	X-3356-604-1	MOTOR (ASSIST) ASSY	

		MISCELLANEOUS	

CNP101	△1-555-795-00	CORD, POWER, EULO PLUG (AEP)	
CNP101	△1-558-945-11	CORD, POWER (POLAR. SPT-1) (US, Canadian)	
IC803	8-759-973-95	IC BA6219B	
PT101	△1-450-100-11	TRANSFORMER, POWER (US, Canadian)	
PT101	△1-450-399-11	TRANSFORMER, POWER (AEP)	
IC1001	8-749-920-97	DIODE GP2S22B	
IC1002	8-749-920-97	DIODE GP2S22B	
S1001	1-466-525-11	ENCORDER, ROTARY	
HRPE1001	A-2003-722-A	DECK ASSY, HEAD	
518	8-719-950-74	LED SLR-314D	

<p>Note: The components identified by mark △ or dotted line with mark △ are critical for safety. Replace only with part number specified.</p>	<p>Note: Les composants identifiés par une marque △ sont critiques pour la sécurité. Ne les remplacer que par une pièce portant le numéro spécifié.</p>
--	---

Ref. No.	Part No.	Description	Remarks
ACCESSORIES & PACKING MATERIALS			

	1-558-271-11	CORD, CONNECTION	
*	3-350-830-01	CUSHION	
*	3-376-443-11	INDIVIDUAL CARTON (AEP)	
*	3-376-443-21	INDIVIDUAL CARTON (US, Canadian)	
	3-754-902-11	MANUAL, INSTRUCTION (ENGLISH, F, E, P) (AEP)	
	3-754-902-21	MANUAL, INSTRUCTION (ENGLISH) (US, Canadian)	
	3-754-902-31	MANUAL, INSTRUCTION (FRENCH) (Canadian)	
	3-754-902-41	MANUAL, INSTRUCTION (D, NL, S, I) (AEP)	

Ref. No.	Part No.	Description	Remarks
HARDWARE LIST			

#1	7-685-534-19	SCREW +BTP 2. 6X8 TYPE2 N-S	
#2	7-682-547-04	SCREW +BVTT 3X6 (S)	
#3	7-621-849-00	SCREW (BV/RING)	
#4	7-685-645-79	SCREW +BVTP 3X6 TYPE2 N-S	
#6	7-685-646-79	SCREW +BVTP 3X8 TYPE2 N-S	
#7	7-621-255-35	SCREW +BVTT 2X5 (S)	
#8	7-621-770-67	SCREW +BVTT 2. 6X6 (S)	
#10	7-685-131-19	SCREW +BTP 2. 6X4 TYPE2 N-S	
#11	7-685-133-19	SCREW +BTP 2. 6X6 TYPE2 N-S	
#12	7-621-255-20	SCREW +BVTT 2X4 (S)	

Note

F : FRENCH NL : DUTCH
 E : SPANISH S : SWEDISH
 P : PORTUGUESE I : ITALIAN
 D : GERMAN