

# TC-S7

## SERVICE MANUAL

US Model  
Canadian Model  
AEP Model  
UK Model

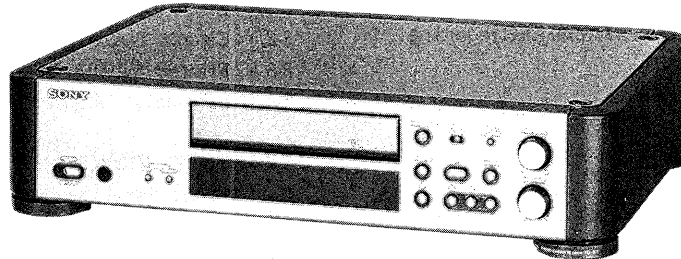

Model Name Using Similar Mechanism	NEW
Tape Transport Mechanism Type	TCM-200V30

### SPECIFICATIONS

Recording system 4-track 2-channel stereo  
Fast-forward and rewind time  
Approx. 90 sec. (with C-60 cassette)  
Bias AC Bias  
Signal-to-noise ratio (NAB, at peak level)

Cassette	Dolby NR switch		
	OFF	B-TYPE ON	C-TYPE ON
TYPE IV (Sony METAL-ES)	60 dB	69 dB	75 dB
TYPE II (Sony UX-S)	59 dB	68 dB	74 dB
TYPE I (Sony HF-S)	57 dB	66 dB	72 dB

Total harmonic distortion  
1.0% (with Sony METAL-ES cassettes)

Frequency response (DOLBY NR OFF)

TYPE IV cassette (Sony METAL-ES)	20 - 20,000 Hz ( $\pm 3$ dB, IEC) 20 - 16,000 Hz ( $\pm 3$ dB, 0 VU (-4 dB) recording)
TYPE II cassette (Sony UX-S)	20 - 18,000 Hz ( $\pm 3$ dB, IEC)
TYPE I cassette (Sony HF-S)	20 - 17,000 Hz ( $\pm 3$ dB, IEC)

Wow and flutter  $\pm 0.09$  % W.Peak (IEC)  
0.05 % WRMS (NAB)  
 $\pm 0.14$  % W.Peak (DIN)

Inputs

Line inputs (phono jacks)	Sensitivity	77.5 mV
	Input impedance	47 k ohms

Outputs

Line outputs (phono jacks)	Rated output level	0.32 V at a load impedance 47 k ohms
	Load impedance	Over 10 k ohms

General

Power requirements

Model for Continental Europe  
220 - 230 V AC, 50/60 Hz  
Model for the United Kingdom  
240 V AC, 50/60 Hz

- Continued on page 2 -

STEREO CASSETTE DECK  
**SONY**<sup>®</sup>

Power consumption 17 watts  
 Dimensions Approx. 430 × 95 × 360 mm  
 (17 × 3<sup>3</sup>/<sub>4</sub> × 14<sup>1</sup>/<sub>4</sub> inches) (w/h/d)  
 including projecting parts and controls  
 Weight Approx. 5.8 kg (12 lb 13 oz)

**Supplied accessory**

Audio connecting cord (2)

Design and specifications subject to change without notice.

**Note**

This appliance conforms with EEC Directive 87/308/EEC regarding interference suppression.

**Flexible Circuit Board Repairing**

- Keep the temperature of the soldering iron around 270°C during repairing.
- Do not touch the soldering iron on the same conductor of the circuit board (within 3 times).
- Be careful not to apply force on the conductor when soldering or unsoldering.



**Notes on chip component replacement**

- Never reuse a disconnected chip component.
- Notice that the minus side of a tantalum capacitor may be damaged by heat.

**TABLE OF CONTENTS**

<u>Section</u>	<u>Title</u>	<u>Page</u>
<b>1. GENERAL</b>	.....	3
<b>2. ADJUSTMENTS</b>	.....	4
<b>3. DIAGRAMS</b>		
3-1.	Block Diagram .....	10
3-2.	Circuit Boards Location .....	12
3-3.	Printed Wiring Boards .....	16
3-4.	Schematic Diagram .....	19
<b>4. EXPLODED VIEWS</b>		
4-1.	Front Panel Section .....	25
4-2.	Rear Panel Section .....	26
4-3.	Mechanism Section (1) .....	27
4-4.	Mechanism Section (2) .....	28
4-5.	Mechanism Section (3) .....	29
<b>5. ELECTRICAL PARTS LIST</b>	.....	30

**SAFETY-RELATED COMPONENT WARNING!!**

COMPONENTS IDENTIFIED BY MARK  OR DOTTED LINE WITH MARK  ON THE SCHEMATIC DIAGRAMS AND IN THE PARTS LIST ARE CRITICAL TO SAFE OPERATION. REPLACE THESE COMPONENTS WITH SONY PARTS WHOSE PART NUMBERS APPEAR AS SHOWN IN THIS MANUAL OR IN SUPPLEMENTS PUBLISHED BY SONY.

# SECTION 1 GENERAL

This section is extracted from instruction manual.

## Location of Controls

## Emplacement des commandes

## Ubicación de los controles

## Localização dos controles

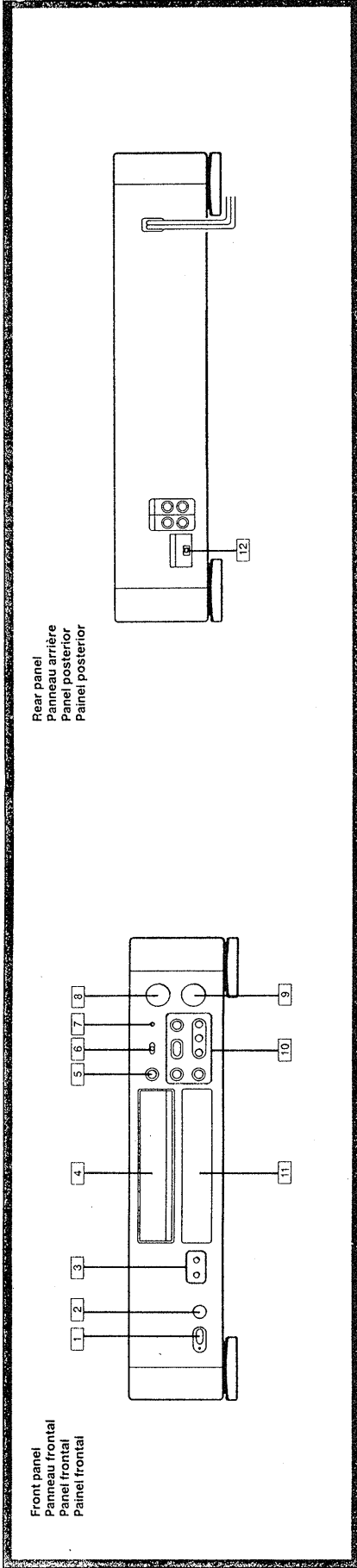

Refer to the pages indicated in ● for details.

Consulter les pages indiquées dans un cercle noir ● pour plus de détails.

Con respecto a los detalles, consulte las páginas indicadas en ●.

Consulte páginas indicadas nos círculos ● para maiores detalhes.

### Cassette deck

- 1 POWER switch and indicator
- 2 Remote sensor
- 3 COUNTER buttons
- 4 MEMORY button
- 5 RESET button
- 6 Cassette tray
- 7 OPEN/CLOSE button
- 8 DOLBY NR switch
- 9 MONITOR button
- 10 REC LEVEL control
- 11 BALANCE control
- 12 Tape operating buttons
- 13 Play button
- 14 Stop button
- 15 Pause button
- 16 Record button
- 17 Record-muting button
- 18 Display window
- 19 MPX FILTER switch

Can be used to remotely control this unit with:

- A remote commander with a **15** mark provided with a Sony amplifier and which can operate a cassette deck.
- An optional Sony remote commander with a **15** mark which can operate a cassette deck.

### Platine à cassette

- 1 Interrupteur d'alimentation et témoin POWER
- 2 Capteur de télécommande
- 3 Touches du compteur COUNTER
- 4 Touche de mémorisation (MEMORY)
- 5 Touche de réinitialisation (RESET)
- 6 Plateau à cassette
- 7 Touche d'ouverture/fermeture (OPEN/CLOSE)
- 8 Interrupteur de réduction de bruit Dolby (DOLBY NR)
- 9 Touche de surveillance (MONITOR)
- 10 Réglage de niveau d'enregistrement (REC LEVEL)
- 11 Réglage de balance (BALANCE)
- 12 Touche d'exploitation de la platine à cassette
- 13 (AMS): Touche d'avance rapide et AMS\*
- 14 (AMS): Touche de rebobinage et AMS\*
- 15 Touche de lecture
- 16 Touche d'arrêt
- 17 Touche de pause
- 18 Touche d'enregistrement
- 19 Touche d'enregistrement/silencieux
- 20 Fenêtre d'affichage
- 21 Commutateur MPX FILTER

Il peut être utilisé pour piloter cet appareil à distance avec:

- Une télécommande avec une marque **15** fournie avec un amplificateur Sony et qui peut exploiter une platine à cassette.
- Une télécommande Sony en option avec une marque **15** et qui peut piloter une platine à cassette.

### Deck de cassettes

- 1 Interrupteur de alimentación (POWER) e indicador
- 2 Sensor de control remoto
- 3 Teclas de memorización (MEMORY)
- 4 Tecla de puesta a cero (RESET)
- 5 Bandeja del cassette
- 6 Tecla de apertura/cierre (OPEN/CLOSE)
- 7 Selector de reducción de ruido Dolby (DOLBY NR)
- 8 Tecla selectora de escucha (MONITOR)
- 9 Control de nivel de grabación (REC LEVEL)
- 10 Control de equilibrio (BALANCE)
- 11 Tecla de operación de la cinta
- 12 (AMS): Tecla de avance rápido y del AMS\*
- 13 (AMS): Tecla de rebobinado y del AMS\*
- 14 Tecla de reproducción
- 15 Tecla de parada
- 16 Tecla de pausa
- 17 Tecla de grabación
- 18 Tecla de silenciamiento de la grabación
- 19 Ventanilla visualizadora
- 20 Interruptor del filtro multiplex (MPX FILTER)

Podrá emplearse para controlar a distancia esta unidad con:

- Un telemando con la marca **15** suministrado con un amplificador Sony y que pueda gobernar decks de cassettes.
- Un telemando Sony opcional con la marca **15** que pueda gobernar decks de cassettes.

### Gravador cassette

- 1 Interruptor e indicador POWER de alimentação
- 2 Sensor remoto
- 3 Teclas COUNTER do contador
- 4 Tecla MEMORY da memória
- 5 Tecla RESET de reinício
- 6 Compartimento de cassetes
- 7 Tecla OPEN/CLOSE de abertura/fechamento
- 8 Interruptor DOLBY NR de redução de ruído
- 9 Tecla MONITOR de monitorização
- 10 Controle REC LEVEL do nível da gravação
- 11 Controle BALANCE de balanço
- 12 Teclas de controle da cassete
- 13 (AMS): avanço rápido e busca automática AMS\*
- 14 (AMS): rebobinagem e busca automática AMS\*
- 15 leitura
- 16 paragem
- 17 pausa
- 18 gravação
- 19 silenciamento da gravação
- 20 Mostrador
- 21 Interruptor MPX FILTER do filtro multiplex

O aparelho pode ser comandado à distância com:

- um telecomando com a marca **15** fornecido com amplificadores com a opção para o comando de gravador cassette;
- Um telecomando Sony opcional com a marca **15** com a opção para o comando de gravador cassette.

\*AMS is the abbreviation of Automatic Music Sensor.

\*AMS es la abreviatura de Automatic Music Sensor: Sensor automático de canciones.

\*AMS é abreviação de Sensor Automático de Música.

## SECTION 2 ADJUSTMENTS

### 1. MECHANICAL ADJUSTMENTS

#### PRECAUTION

1. Clean the following parts with a denatured-alcohol-moistened swab :
 

record/playback head	pinch roller
erase head	rubber belts
capstan	idler
2. Demagnetize the record/playback head with a head demagnetizer.
3. Do not use a magnetized screwdriver for the adjustment
4. After the adjustments, apply suitable locking compound to the parts adjusted.

#### Tape Path Adjustment

**Note :** When using the adjustment methods for other than replacement reasons, please do not tamper unnecessarily with the adjustment screws or the erasehead because the record/playback head will be made the standard tape paths. Moreover, when it is necessary to adjust and replace two or more of any of the heads one, completely taking out the first tape path, and then replacing the second one.

#### Preparation :

1. Mirror cassette CQ009C 8-909-708-01  
(or CQ012C 8-909-708-02)

If one does not have this, cut out the sections of a 120-minute cassette shell as indicated below and use that cassette.

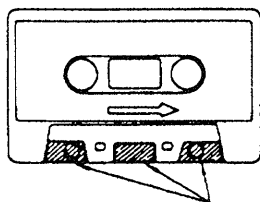

Cut out

2. Phillips screwdriver (medium-size) :  
For the head adjustment screws
3. Pen light
4. WS-48B (3kHz, 0dB)
5. P-4-A100 (10kHz, -10dB)

**Adjustment Position :** As seen from the cassette, side (top) and MD as seen head on (bottom).

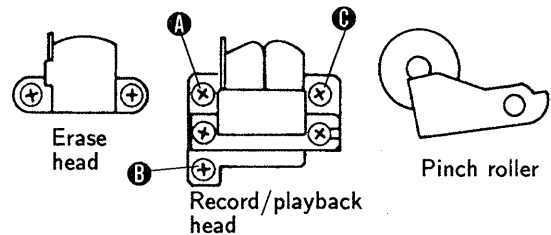
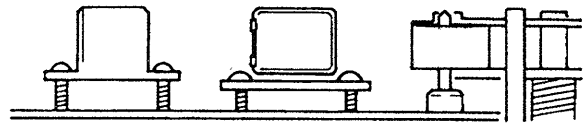

**Definition of Terms :** The figures are of a record/playback head.

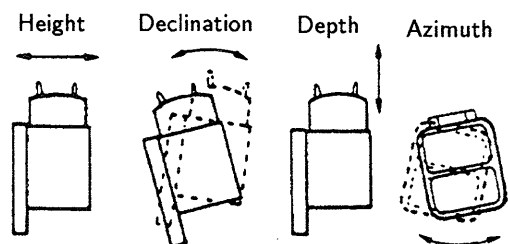

#### Record/playback head

**Note :** Only perform this adjustment when the record/playback head is to be replaced.

1. Insert the mirror cassette and put the unit in record/playback mode.
2. (**Height Adjustment**) Check to see if the tape is curling at the tape guide of the head. If it is curling, tighten screws **A**, **B**, and **C**, respectively by the same angle, moving the head so that it remains at the same angle throughout the procedure. If it curls on the bottom side of the mirror cassette (actually the inner side), tighten all the screws equally ; but loosen them if the tape begins to curl on the top side (outer side).

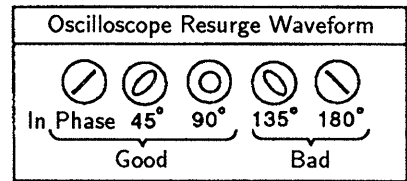
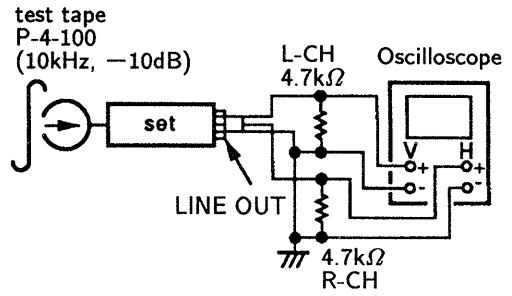
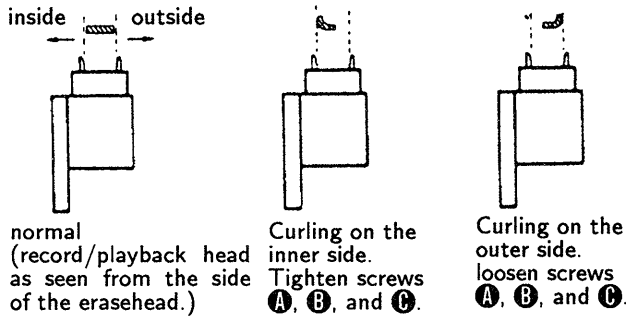

3. **(Declination Adjustment)** While in the record/playback position, set the back tension to 0 (wind the supply reel with something thin like a pencil counterclockwise direction) and make sure there is no curling or shifting (shifting up/shifting down) at the guide of the record/playback head.

Because shifting can only occur due to a difference in the width of the tape and that of the tape guides (curling will otherwise occur), it is necessary to pay close attention since it can be easily overlooked.

When there is a shift, tighten screws **B** and **C** equally and change the declination of the head. If it is shifting down, loosen them.

4. Repeat the adjustments in steps 2 and 3 and fine adjust the height and the declination.

5. **(Preliminary Azimuth Adjustment)**

After demagnetizing and cleaning the adjustment head, play back WS-48B (3kHz, 0dB).

Turn screw **C** so that the reading on the level meter of the unit or that of the level meter connected to LINE OUT is maximized.

If the screw is turned at least half a revolution, repeat the adjustment from step 1.

6. **(Tape Path Check)** Connect the oscilloscope to LINE OUT and play back P-4-A100 (10kHz, -10dB) to display a resurge waveform. After 20 seconds of record/playback (after the tension within the loop has been increased sufficiently), make sure the variation in the resurge is within  $\pm 90$  degrees (within  $\pm 45$  degrees is desired).

If the variation is greater than this, it is because the declination and/or the height adjustments from step 1.

### TORQUE MEASUREMENT

Torque	Torque meter	Meter reading
FWD	CQ-102C	28 - 60g.cm (0.39 - 0.83oz. inch)
FWD Back tension	CQ-102C	1 - 5g.cm (0.014 - 0.069oz. inch)
FF, REW	CQ-201B	65 - 90g.cm (0.9 - 1.25oz.inch)

### Pinch Roller Pressing Force Measurement

Mode : playback

Hook needle of the tension gauge to the pinch roller shaft and push back pinch roller to detach it from capstan. Then, return it gradually to capstan and read the gauge when the pinch roller begins turning.

Standard Limits :

210 - 320g (7.4 - 11.3oz)

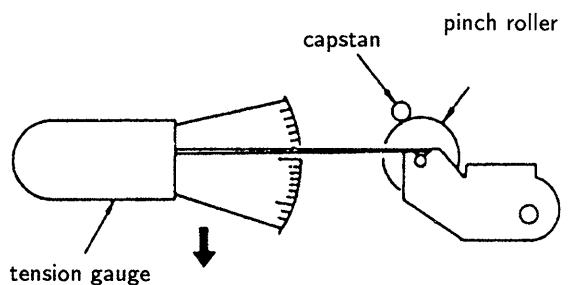

## 2. ELECTRICAL ADJUSTMENT

**Note :** The adjustment should be performed in the order given in the service manual. As a rule, adjustments about playback should be performed before those about recording.

The adjustment should be performed before for both L-CH and R-CH.

Switches and controls should be set as follows unless otherwise specified.

DOLBY NR switch : OFF

MPX FILTER switch : OFF

TAPE/SOURCE switch : Tape

Standard Record :

Deliver the standard input signal level to the input jack and set the REC LEVEL control to obtain the standard output signal level.

### — Record Mode —

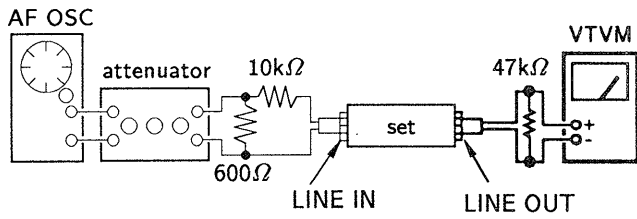

### Standard Input Level

input terminal	LINE IN
source impedance	10kΩ
input level	0.25V (-10dB)

### Standard Output Level

output terminal	LINE OUT
load impedance	47kΩ
output level	0.35V (-7.7dB)

### Test Tape

Type	Signal	Used for
P-4-A100	10kHz, -0dB	Azimuth Adjustment
P-4-L300	315Hz, 0dB	PB Level Adjustment
WS-48B	3kHz, 0dB	Tape Speed Adjustment

### Test Mode

This set will get into test mode by shorting the pins of TP803 on Audio system control board before turning the power on.

### Record/Playback Head Azimuth Adjustment

#### Porcedure :

1. Mode : FWD playback

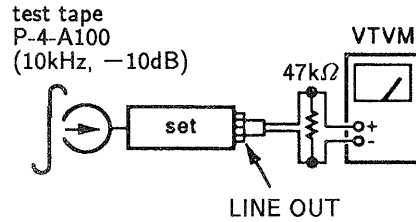

2. Turn the adjustment screw for the maximum output levels. If these levels do not match, turn the adjustment screw until both output levels match together within 1dB.

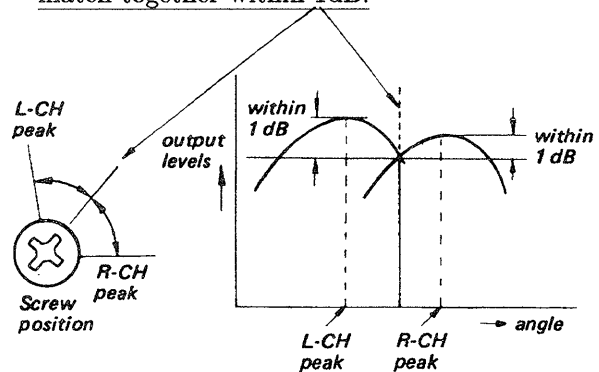

3. Phase Check

Mode : playback

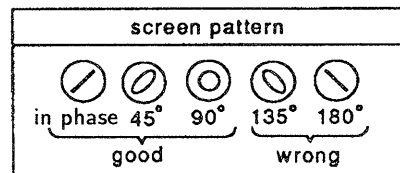
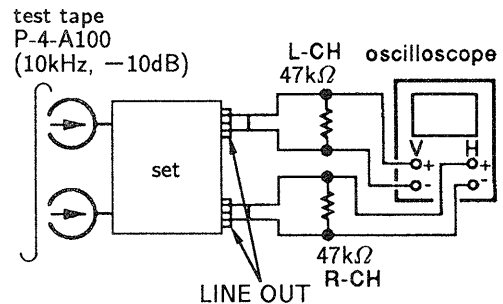

4. After the adjustment, lock the screws with locking compound.

**Adjustment Location :** Record/Playback head

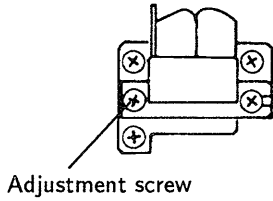

**Tape Speed Adjustment**

**Setting :**

Test pin TP803 short

**Procedure :**

Mode : playback

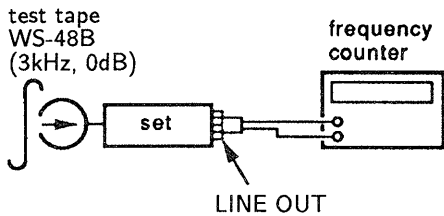

1. Set to playback mode.
2. Adjust motor rear side (variable resister) so that the frequency counter reading becomes  $3,000 \pm 15\text{Hz}$ .

**Adjustment Location :** motor rear side.

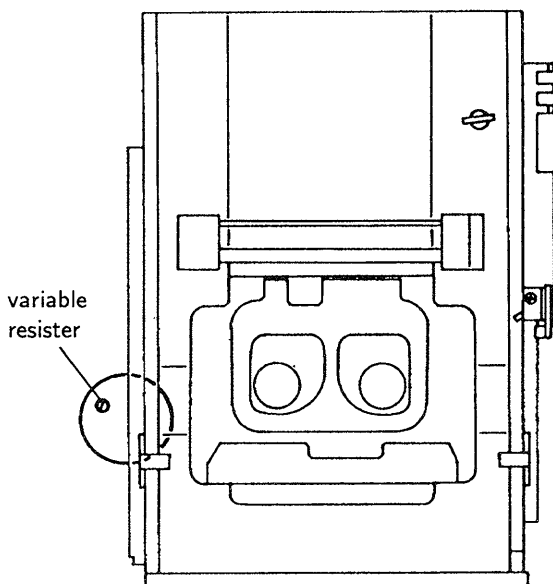

**Playback Level Adjustment**

**Procedure :**

Mode : playback

test tape  
P-4-L300  
(315Hz, 0dB)

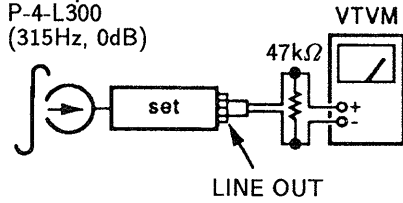

Adjust RV121 (L-ch) and RV221 (R-ch) so that the reading on VTVM meets the adjustment limits below.

**Adjustment Limits :**

LINE OUT level :  $-7.7 \pm 0.5\text{dB}$  (0.33 - 0.37V)

Level difference between channels : less than 0.5dB.

Check that the LINE OUT level does not change even if Playback and Stop operation is repeated several times.

**Adjustment Location :** Audio system control board

**Bais Consumption current Adjustment**

**Procedure :**

LINE IN  
(no signal) CS-413 blank tape

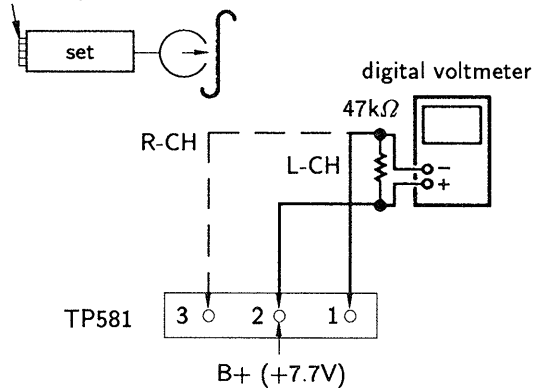

1. Set RV181 and RV281 to mechanical center and turn the set recording mode.
2. Connect digital voltmeter as shown by the following table.
3. Adjust the folowing transformers for the minimum readings on the digital voltmeter.

	Measurement Point	Adjustment Part	Value
L-ch	① and ②, TP581	T181	not more than 200mV
R-ch	③ and ②, TP581	T281	

**Adjustment Location :** Audio system control board

### Record Bias Adjustment

**Setting :**

REC LEVEL control : Standard Record (see page ).  
test pin TP803 : short

**Procedure :**

1. Mode : record

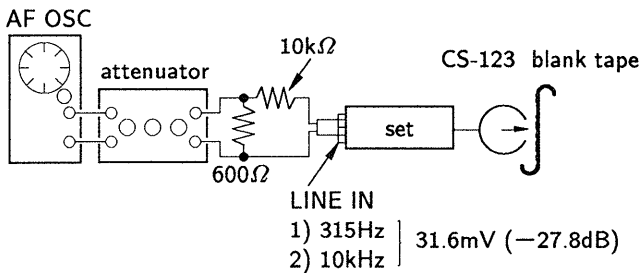

1. Mode : playback

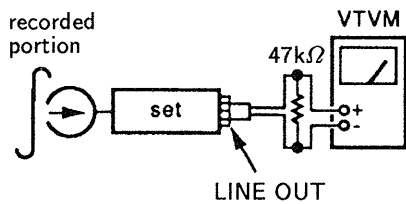

Playback the signal recorded in step 1.  
Confirm that the 10kHz playback output is  $0 \pm 0.5$  dB relative to the 315Hz output. If necessary, adjust RV181 (L-ch) and RV281 (R-ch) for repeat the steps given above.

**Adjustment Location :** Audio system control board

### Record Level Adjustment

**Setting :**

REC LEVEL control : Standard Record (see page )  
test pin TP803 : short

**Procedure :**

1. Mode : record

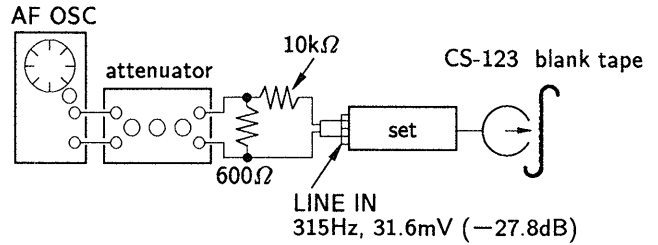

2. Mode : playback

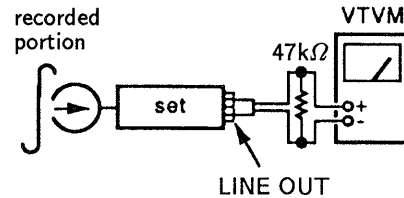

3. Playback the signal recorded in step 1.

Confirm that the signal level is within the adjustment limits below. If necessary, adjust RV 141 (L-ch) and RV241 (R-ch) repeat the step 1 2.

**Adjustment Limits :**

$$-27.8\text{dB} \pm 0.5\text{dB} \text{ (29 to 33.4mV)}$$

**Adjustment Location :** Audio system control board



**Adjustment Location**

— Audio system control board (component side) —

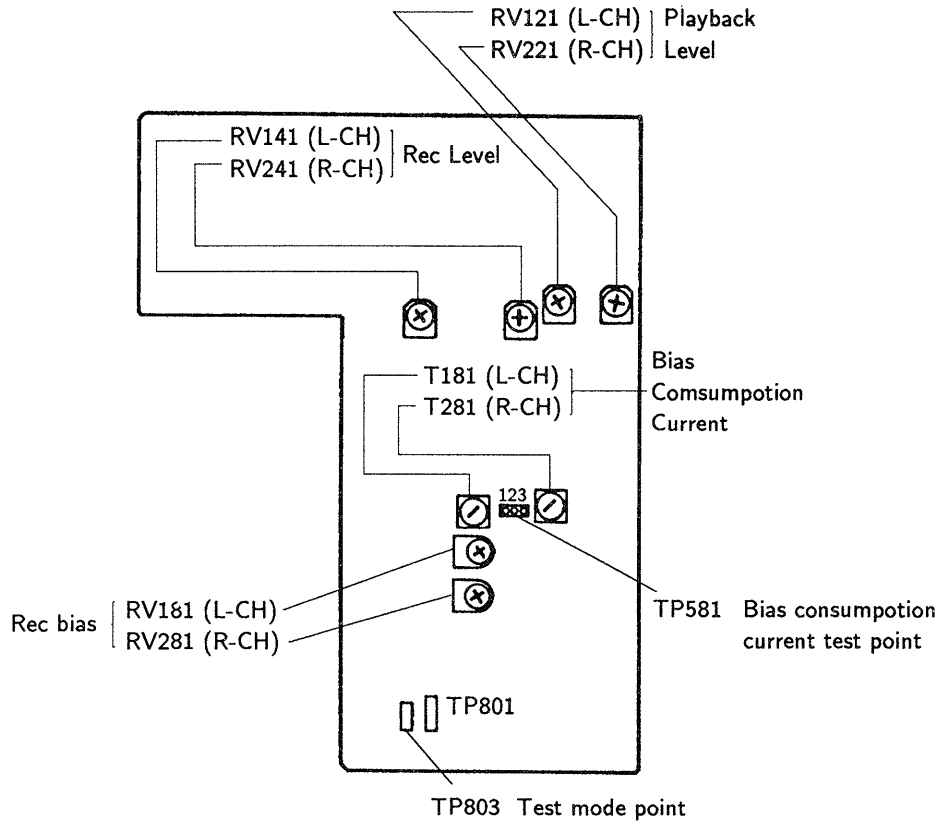

SECTION 3

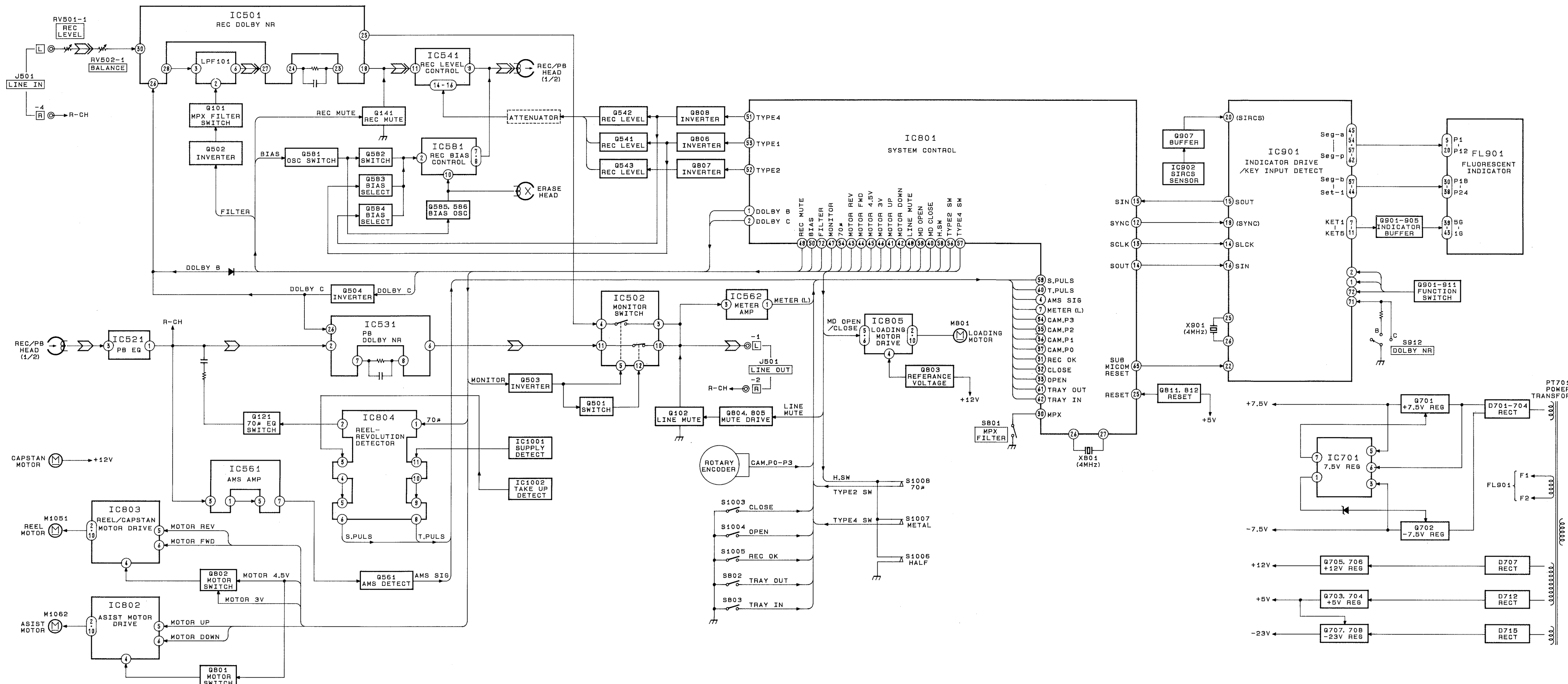

3-2. CIRCUIT BOARDS LOCATION

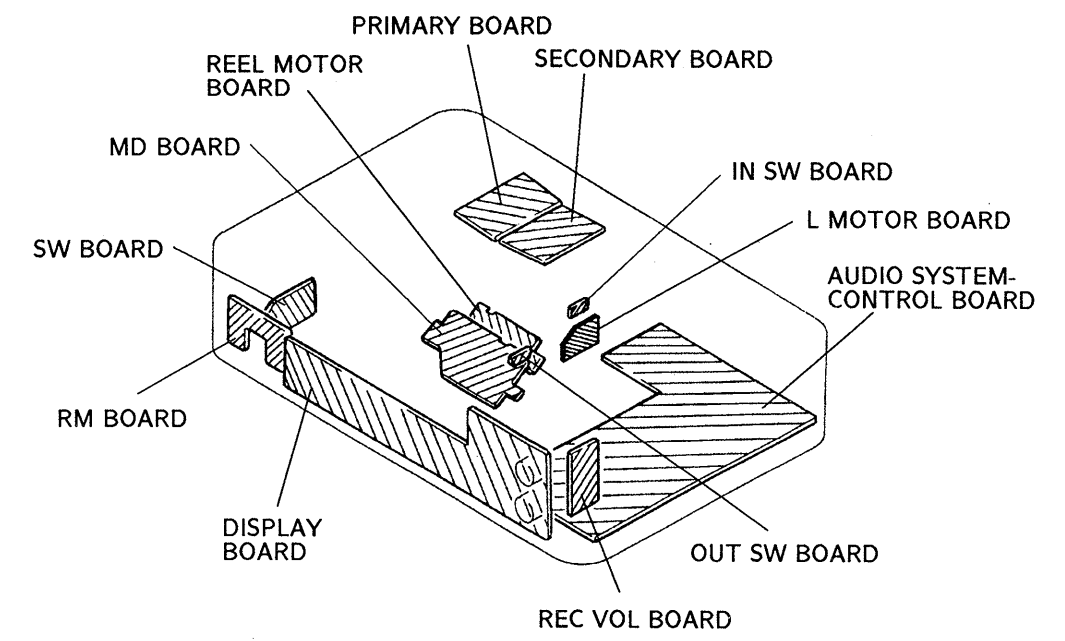

• SEMICONDUCTOR LEAD LAYOUTS

EC10QS-04  
EC10DS2

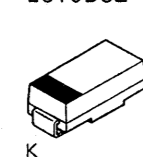

1SS355

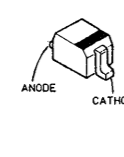

2SB1116A-L  
2SC945-P

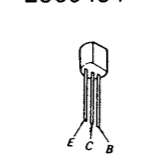

RBA-402

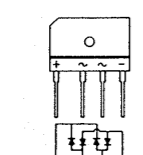

CD4066BCM  
CD4069BCM-FL63

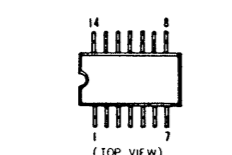

2SA1317-STU  
2SA1344

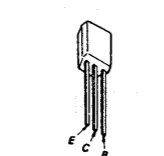

UZL-12M1  
HZS-6A1L  
HZS-7A1L

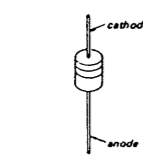

M50940-334FP  
M50964-255FP

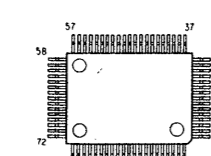

2SB1370-EF

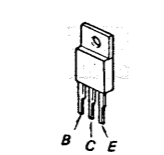

UZL-7H1  
10E2N

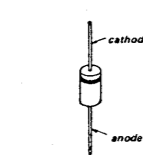

CXA1331M

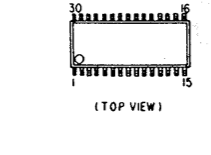

SEL2510C-D

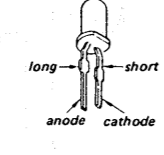

GP2S22B

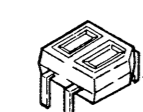

2SD2012

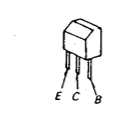

• SEMICONDUCTOR LOCATION

Ref. No.	Location	Ref. No.	Location
D161	F-5	Q101	B-4
D261	F-4	Q102	B-3
D501	J-3	Q121	E-2
D541	G-4	Q141	F-3
D542	G-4	Q201	B-3
D543	G-4	Q202	B-3
D544	D-4	Q221	E-1
D561	F-4	Q241	E-3
D582	H-1	Q501	B-1
D583	G-4	Q502	B-2
D584	H-4	Q503	B-2
D701	B-7	Q504	B-2
D702	B-7	Q541	G-4
D703	C-7	Q542	G-4
D704	C-7	Q543	G-4
D705	B-5	Q561	F-4
D706	B-7	Q581	H-2
D707	C-8	Q582	H-2
D711	C-8	Q583	G-4
D712	D-8	Q584	H-4
D713	C-5	Q585	G-2
D714	B-8	Q586	G-2
D715	D-6	Q701	A-6
D716	D-6	Q702	A-7
D717	D-6	Q703	C-6
D801	H-4	Q704	B-6
D802	I-5	Q705	A-8
D803	I-5	Q706	B-8
D805	K-1	Q707	D-5
D806	G-5	Q708	D-6
D807	G-5	Q801	G-4
D901	I-15	Q802	H-5
		Q803	J-5
		Q804	K-2
		Q805	K-2
IC1001	I-19	Q806	K-2
IC1002	I-20	Q807	K-2
IC501	C-3	Q808	K-2
IC502	B-2	Q811	I-1
IC521	F-2	Q812	I-1
IC531	D-2	Q901	J-10
IC541	F-3	Q902	J-10
IC561	F-5	Q903	J-11
IC562	F-5	Q904	J-11
IC581	H-3	Q905	J-11
		Q907	J-13
IC701	B-5		
IC801	J-2		
IC802	G-5		
IC803	I-5		
IC804	I-4		
IC805	J-5		
IC901	J-12		
IC902	G-15		

Note:

- : parts extracted from the component side.
- : parts extracted from the conductor side.
- : parts mounted on the conductor side.
- ▣ : indicates side identified with part number.
- ▤ : Pattern on the side which is seen.
- ▥ : Pattern of the rear side.
- (with dot) : Through hole.

3-3. PRINTED WIRING BOARDS

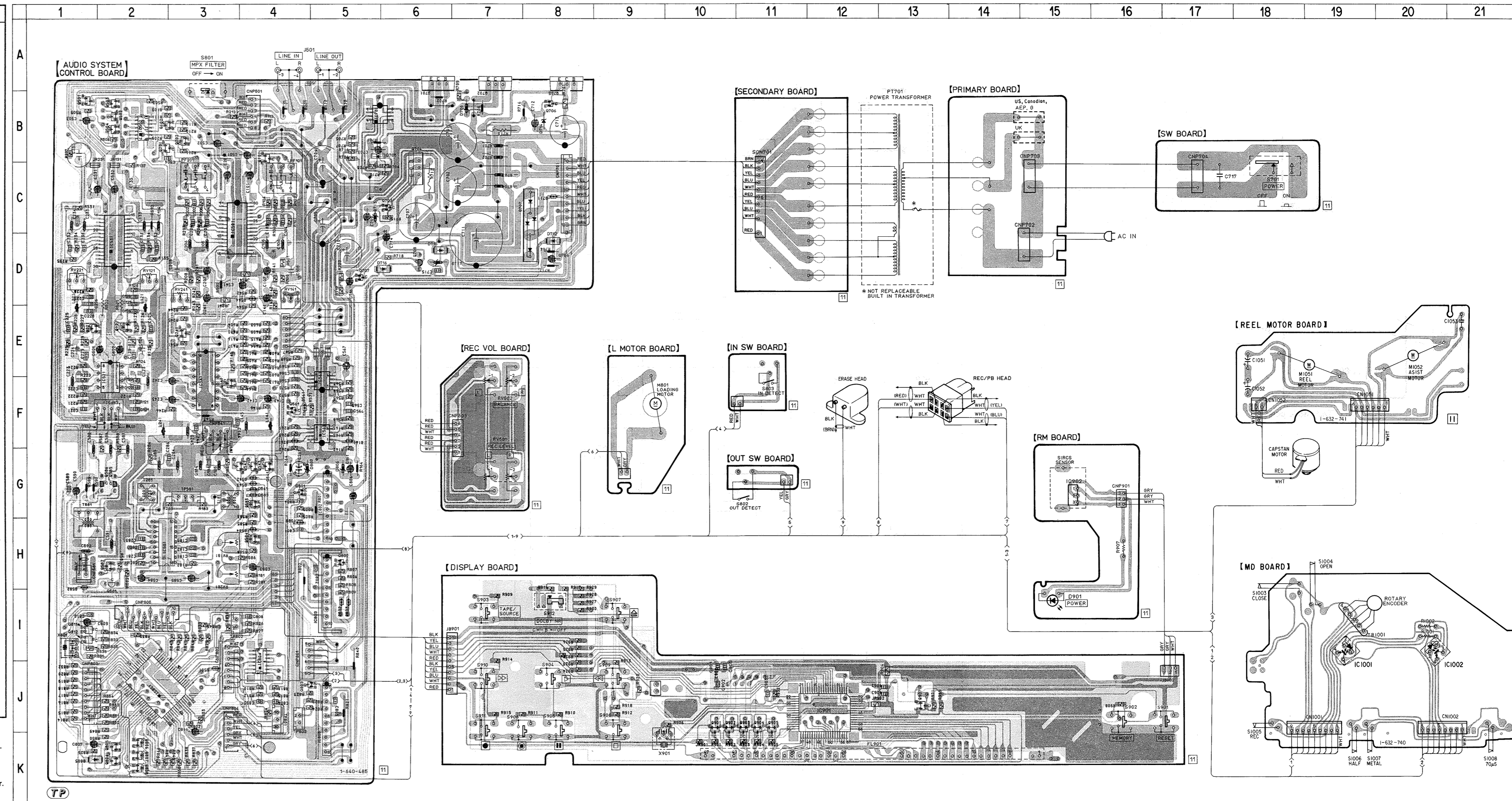

TP

3.4. SCHEMATIC DIAGRAM

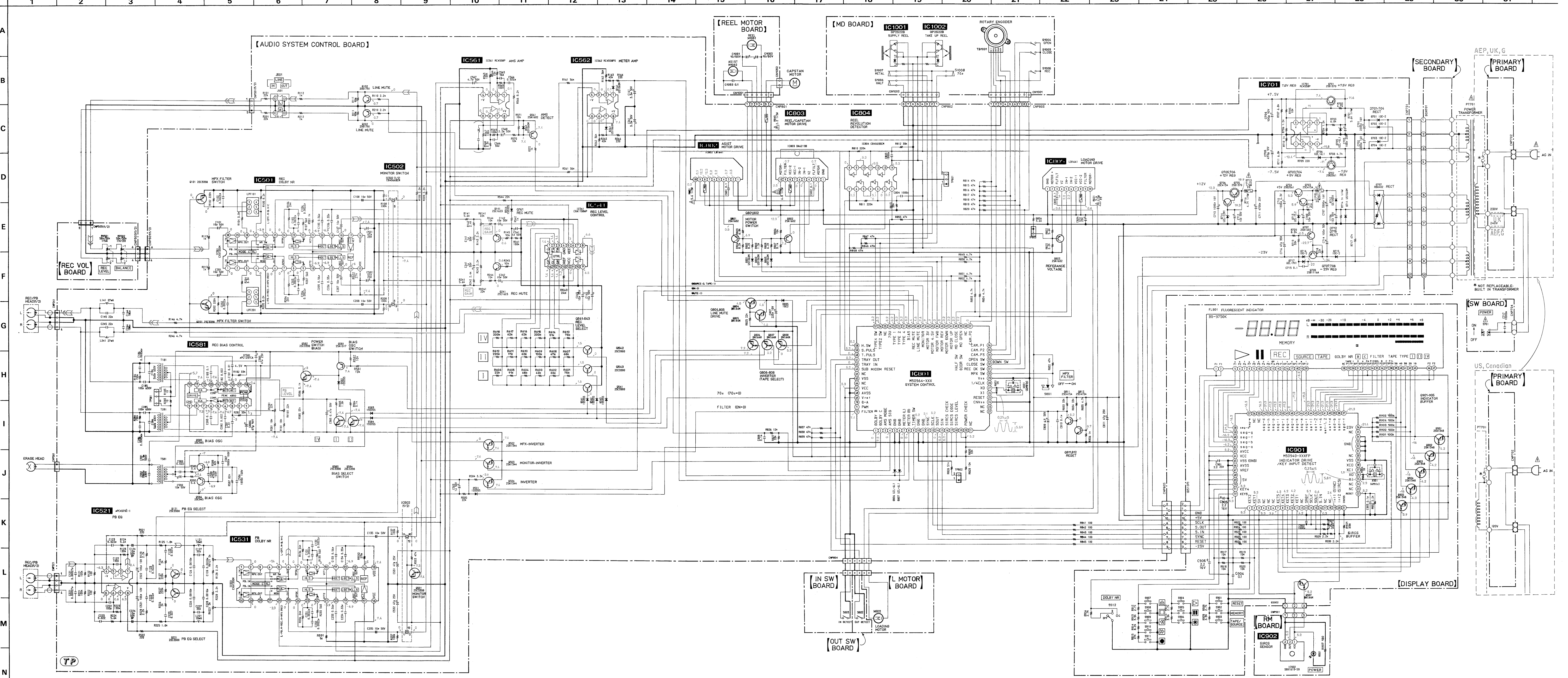

## SECTION 4 EXPLODED VIEWS

**NOTE:**

- -XX, -X mean standardized parts, so they may have some differences from the original one.
- The construction parts of an assembled part are indicated with a collation number in the remark column.
- Color indication of Appearance Parts  
Example:  
KNOB, BALANCE (WHITE)...(RED)  
  ↑  ↑  
  Parts color                        Cabinet's color

- Items marked "\*" are not stocked since they are seldom required for routine service. Some delay should be anticipated when ordering these items.
- The mechanical parts with no reference number in the exploded views are not supplied.
- Hardware (#mark) list is given in the last of this parts list.

The components identified by mark ⚠ or dotted line with mark ⚠ are critical for safety. Replace only with part number specified.

**4-1. FRONT PANEL SECTION**

● B—● E: See page (26)

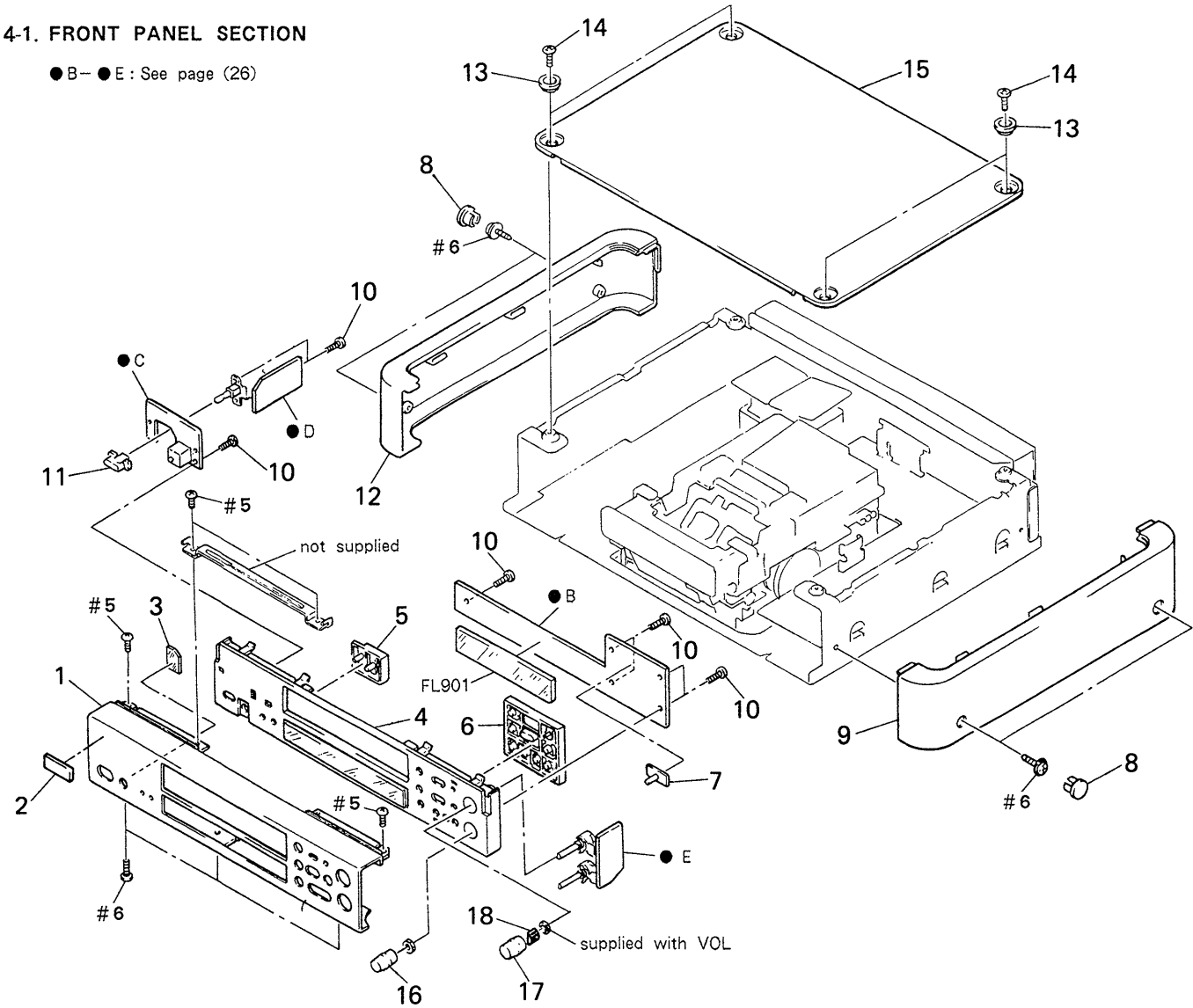

Ref. No.	Part No.	Description	Remark	Ref. No.	Part No.	Description	Remark
1	3-371-602-01	PANEL, FRONT		11	4-946-889-01	BUTTON (POWER)	
2	4-946-905-01	ENBLEM (NO. 4, 5), SONY		12	4-946-890-01	PANEL (L), SIDE	
3	4-946-888-01	WINDOW (REMOTE CONTROL)		13	4-928-025-11	ESCUTCHEON (TOP PLATE)	
4	X-3363-552-1	PANEL (BASE) ASSY		14	3-721-187-01	SCREW (3X8)	
5	3-371-599-01	BUTTON (COUNTER)		15	* 4-946-439-11	PLATE, TOP	
6	3-371-600-01	BUTTON (BLOCK)		16	3-371-591-11	KNOB (ROUND 18)	
7	3-371-595-01	KNOB (DOLBY)		17	3-371-591-01	KNOB (ROUND 18)	
8	4-946-893-01	CAP (SIDE PANEL)		18	3-703-466-00	SPRING (6600)	
9	4-946-891-01	PANEL (R), SIDE		FL901	1-519-680-11	INDICATOR TUBE, FLUORESCENT	
10	4-928-635-01	SCREW, +BV (2.6X8) TAPPING					

## 4-2. REAR PANEL SECTION

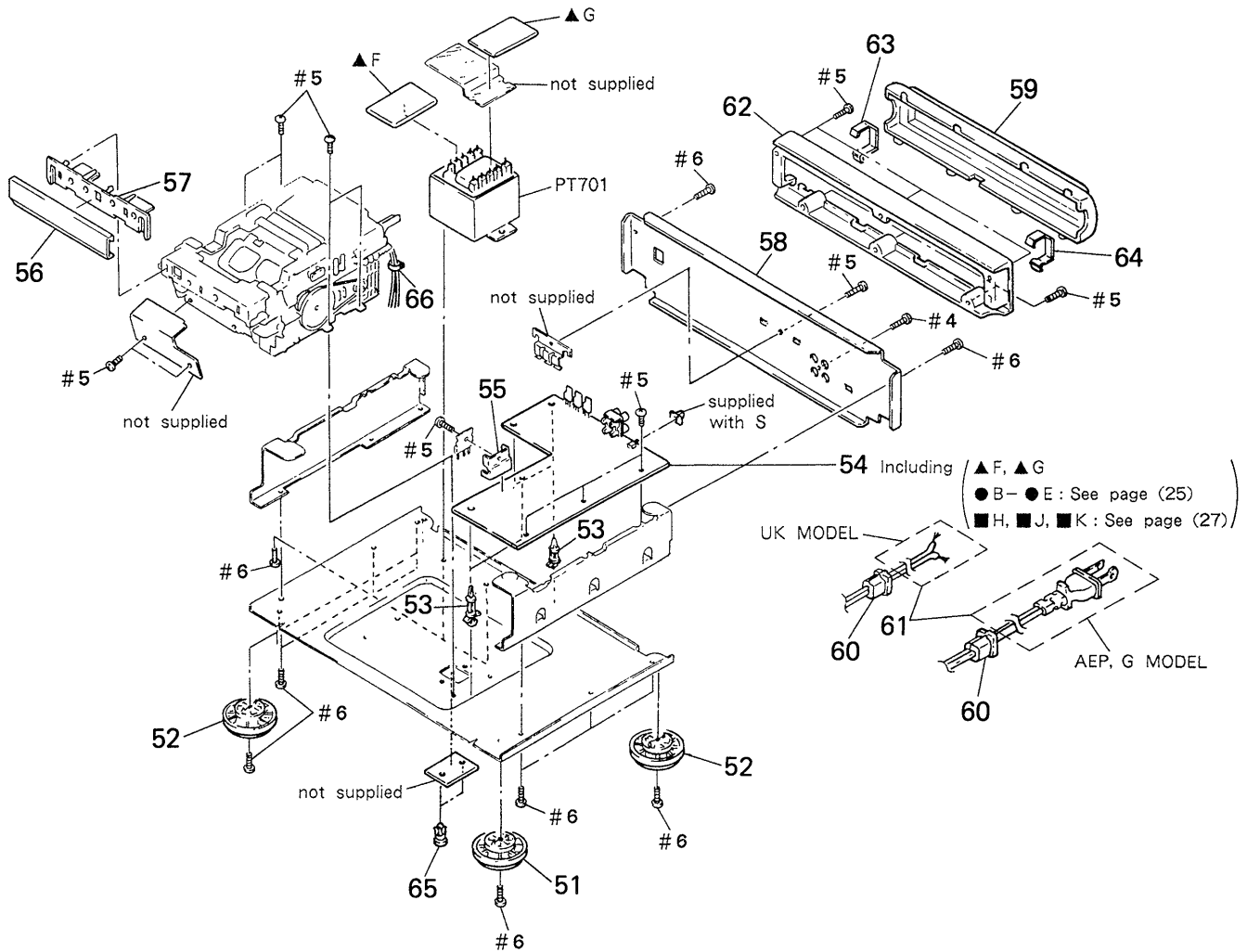

**Note:** The components identified by mark ▲ or dotted line with mark ▲ are critical for safety. Replace only with part number specified.

Ref.No.	Part No.	Description	Remark
51	X-3363-549-1	FOOT ASSY	
52	X-3363-548-1	FOOT ASSY	
53	* 3-346-265-11	HOLDER, PC BOARD	
54	* A-2006-578-A	AUDIO SYSCON BOARD, COMPLETE	
55	* 3-356-925-01	HEAT SINK	
56	3-371-598-01	PANEL, LOADING	
57	3-371-597-01	ESCUTCHEON (LOADING PANEL)	
58	* 3-370-076-11	PANEL, BACK (UK)	
58	* 3-370-076-21	PANEL, BACK (AEP, G)	
58	* 3-370-076-31	PANEL, BACK (AEP)	
58	* 3-370-076-01	PANEL, BACK (US, Canadian)	

Ref.No.	Part No.	Description	Remark
59	4-946-444-01	COVER, REAR	
60	* 3-703-244-00	BUSHING (2104), CORD	
61	▲ 1-558-946-21	CORD, POWER (UK)	
61	▲ 1-575-651-21	CORD, POWER (AEP, G)	
61	▲ 1-590-836-11	CORD, POWER (US, Canadian)	
62	* 4-946-443-01	MOLD, REAR	
63	4-946-447-01	HOLDER (L)	
64	4-946-448-01	HOLDER (R)	
65	3-531-576-01	RIVET	
66	3-655-653-21	BAND (TAITON), BINDING	
PT701	▲ 1-450-631-11	TRANSFORMER, POWER (AEP, UK, G)	
PT701	▲ 1-450-630-11	TRANSFORMER, POWER (US, Canadian)	

### 4-3. MECHANISM SECTION (1)

■ H, ■ J, ■ K : See page (26)

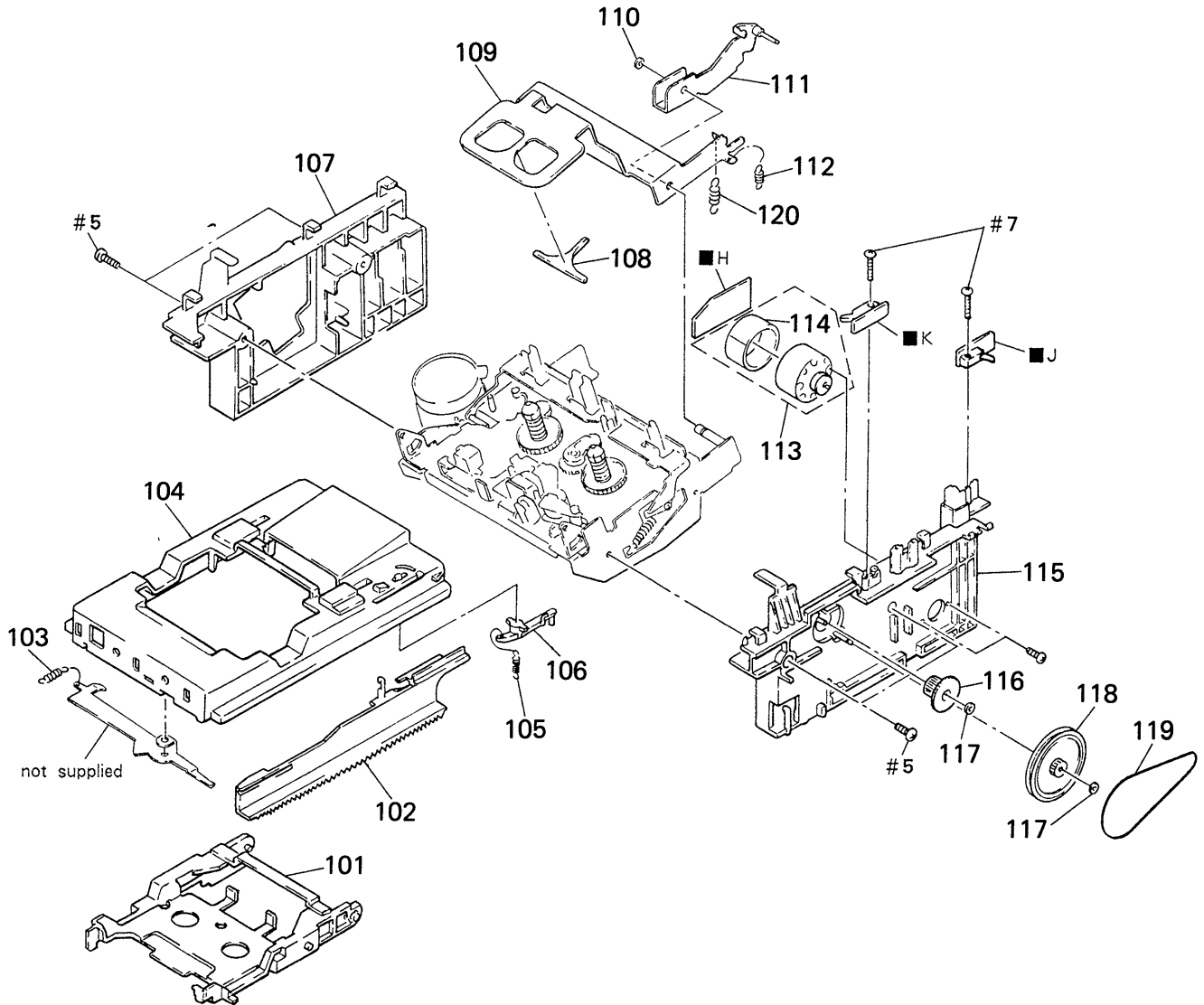

Ref. No.	Part No.	Description	Remark
101	3-371-624-01	RETAINER	
102	3-371-625-01	RACK	
103	3-371-628-01	SPRING (RETAINER), TENSION	
104	3-371-623-01	TRAY	
105	3-371-629-01	SPRING (LOCK LEVER), TENSION	
106	3-371-626-01	LEVER (LOCK)	
107	3-371-615-01	GUIDE (L)	
108	3-371-622-01	CUSHION (STABILIZER)	
109	* 3-371-621-01	LEVER (HALF RETAINER)	
110	3-696-510-01	WASHER (3), STOPPER	

Ref. No.	Part No.	Description	Remark
111	* X-3363-554-1	LEVER (LIMITER) ASSY	
112	3-371-619-01	SPRING (LIMITER), TENSION	
113	A-2003-936-A	MOTOR (LOADING) ASSY	
114	* 3-162-496-01	CORE, SHIELD	
115	X-3363-556-1	GUIDE (R) ASSY	
116	3-371-617-01	GEAR (DRIVING)	
117	3-669-465-00	WASHER (1.5), STOPPER	
118	3-371-616-01	PULLEY (MIDWAY)	
119	3-371-620-01	BELT (LOADING)	
120	3-371-618-01	SPRING (STABILIZER), TENSION	

#### 4-4. MECHANISM SECTION (2)

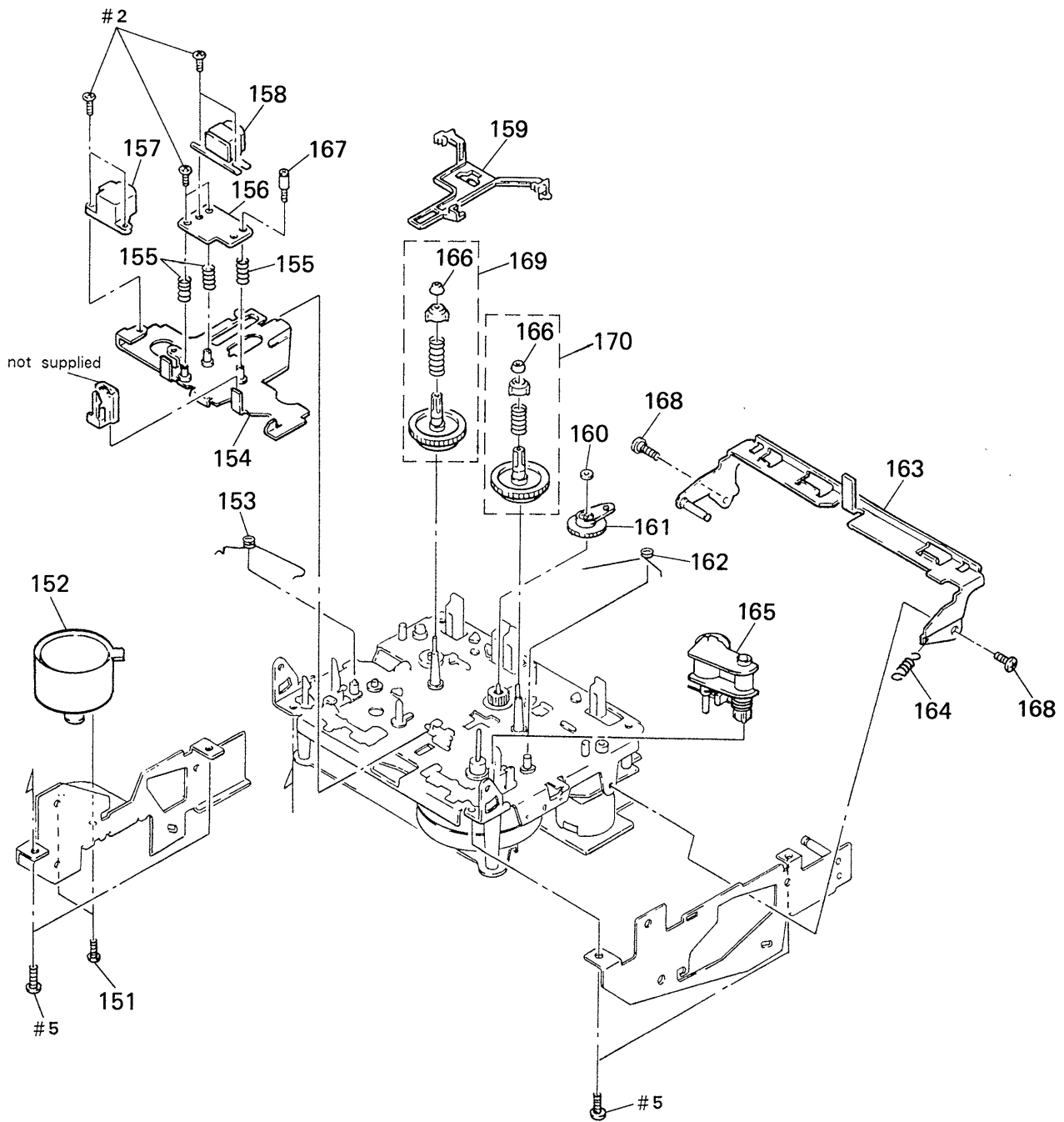

Ref. No.	Part No.	Description	Remark	Ref. No.	Part No.	Description	Remark
151	4-885-599-00	SCREW, FITTING, REINFORCEMENT		161	X-3356-641-1	LEVER (FR2) ASSY	
152	X-3363-546-1	MOTOR (CAPSTAN V30) ASSY		162	3-356-619-01	SPRING (B), TORSION	
153	3-371-565-01	SPRING, TORSION		163	* X-3363-542-1	LEVER (LIFTER) ASSY	
154	X-3363-547-1	SLIDER (HEAD PCB V30) ASSY		164	3-356-625-01	SPRING, TENSION	
155	3-356-659-01	SPRING (RPH), COMPRESSION		165	X-3356-649-1	LEVER (PINCH LEVER T) ASSY	
156	3-371-572-01	BRACKET (GUIDE R)		166	3-356-618-01	CAP (REEL)	
157	1-543-535-11	HEAD, MAGNETIC (ERASE)		167	3-371-630-01	SCREW (AZIMUTH), STEP	
158	1-543-733-11	HEAD, MAGNETIC (RECORD/PLAYBACK)		168	3-371-631-01	SCREW (LIFTER), STEP	
159	3-356-614-01	SLIDER (BRAKE)		169	X-3356-628-1	GEAR (S) ASSY	
160	3-669-465-11	WASHER (1.5), STOPPER		170	X-3356-627-1	GEAR (T) ASSY	



4-5. MECHANISM SECTION (3)

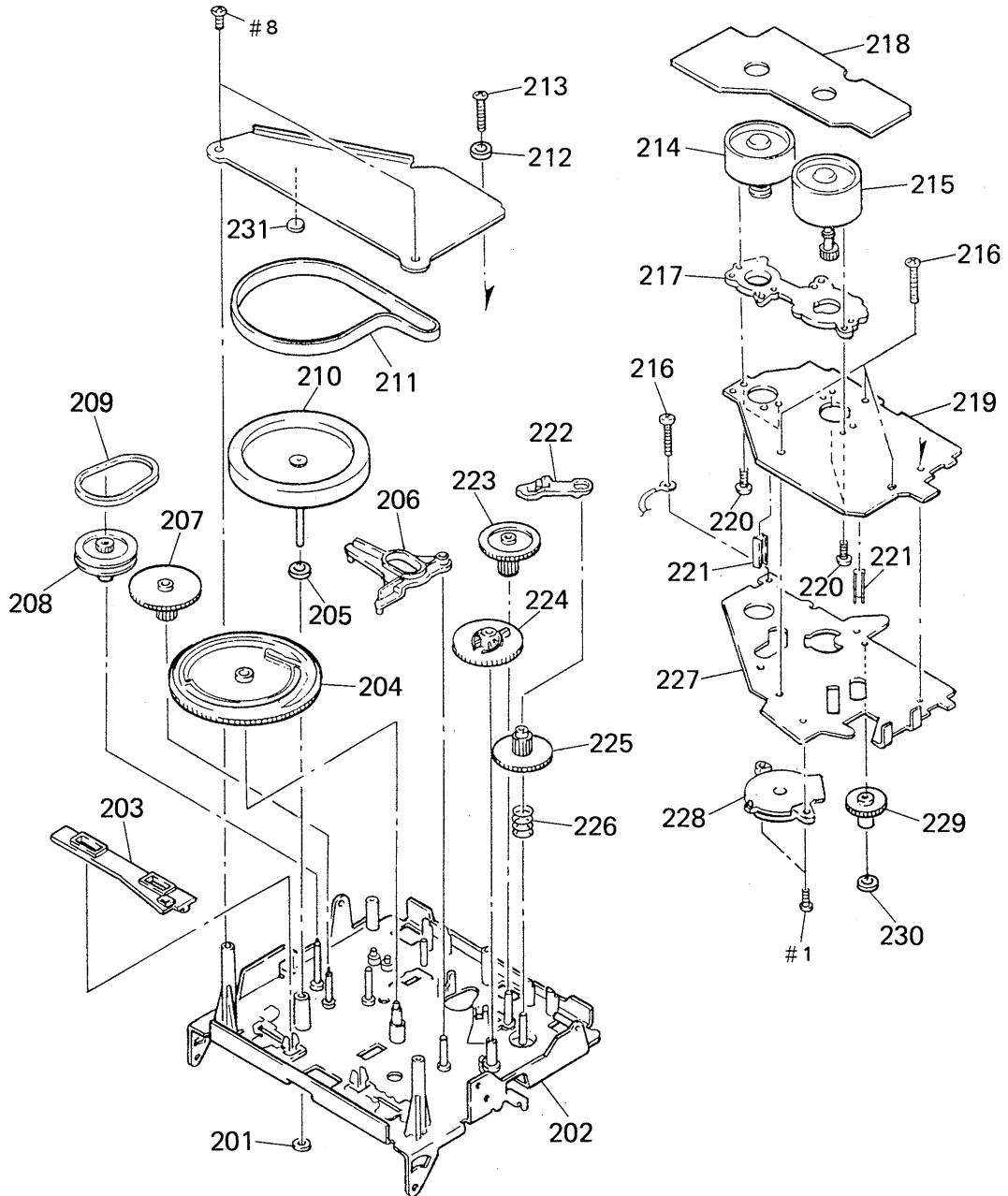

Ref. No.	Part No.	Description	Remark
201	3-356-713-01	WASHER	
202	* X-3363-544-1	CHASSIS (V30) COMPLETE ASSY, MECH	
203	3-356-653-01	SLIDER (PAUSE)	
204	3-356-747-01	GEAR (MODE CAM C)	
205	3-356-705-01	WASHER (CAPSTAN)	
206	3-356-613-01	LEVER (MODE)	
207	3-356-606-01	GEAR (MODE)	
208	3-356-607-01	PULLEY (MODE)	
209	3-356-603-01	BELT (MODE)	
210	X-3356-642-1	FLYWHEEL (R FWD) ASSY	
211	3-371-571-01	BELT (CAPSTAN)	
212	* 3-356-718-01	SPACER (THRUST RETAINER R)	
213	3-356-707-01	SCREW (+PTPW 2X25)	
214	X-3356-604-1	MOTOR (ASSIST) ASSY	
215	X-3356-638-1	MOTOR (REEL R) ASSY	

Ref. No.	Part No.	Description	Remark
216	3-355-801-01	SCREW (BTP 2X18)	
217	* 3-356-628-01	SPACER (MOTOR)	
218	* 1-632-741-11	PC BOARD, REEL MOTOR	
219	* 1-632-740-11	PC BOARD, MD	
220	3-363-804-01	SCREW (+P 2.6X6.5)	
221	3-356-631-03	HOLDER (SENSOR)	
222	3-356-617-01	LEVER (SELECTION)	
223	3-356-703-01	GEAR (COMMUNICATION C)	
224	3-356-616-01	GEAR (LOADING CAM)	
225	3-356-609-01	GEAR (LOADING)	
226	3-356-605-01	SPRING, COMPRESSION	
227	* X-3356-602-1	BRACKET (MOTOR R) ASSY	
228	1-466-238-11	ENCODER, ROTARY	
229	3-356-702-01	GEAR (COMMUNICATION B)	
230	3-669-465-00	WASHER (1.5), STOPPER	
231	3-371-570-01	SPACER (THRUST RETAINER)	

SECTION 5

ELECTRICAL PARTS LIST

AUDIO SYSCON

NOTE:

- Due to standardization, replacements in the parts list may be different from the parts specified in the diagrams or the components used on the set.
- -XX, -X mean standardized parts, so they may have some difference from the original one.
- RESISTORS  
All resistors are in ohms  
METAL :Metal-film resistor  
METAL OXIDE :Metal Oxide-film resistor  
F :nonflammable

- Items marked "\*" are not stocked since they are seldom required for routine service. Some delay should be anticipated when ordering these items.
- SEMICONDUCTORS  
In each case, u:  $\mu$ , for example:  
uA.....:  $\mu$ A....., uPA.....:  $\mu$ PA.....  
uPB.....:  $\mu$ PB....., uPC.....:  $\mu$ PC.....  
uPD.....:  $\mu$ PD.....
- CAPACITORS  
uF:  $\mu$ F
- COILS  
uH:  $\mu$ H

The components identified by mark  $\Delta$  or dotted line with mark  $\Delta$  are critical for safety. Replace only with part number specified.

When indicating parts by reference number, please include the board name.

Ref. No.	Part No.	Description	Remark	Ref. No.	Part No.	Description	Remark
	* A-2006-578-A	AUDIO SYSCON BOARD, COMPLETE *****		C144	1-163-257-91	CERAMIC CHIP 180PF	5% 50V
	* 1-562-327-00	SOCKET, CONNECTOR 3P		C145	1-136-935-11	FILM 22PF	5% 630V
	1-690-123-61	REED (WITH CONNECTOR) (2 CORE)		C161	1-123-382-00	ELECT 3.3uF	20% 100V
	* 3-356-925-01	HEAT SINK		C181	1-163-021-91	CERAMIC CHIP 0.01uF	10% 50V
	7-682-547-04	SCREW +BVTT 3X6 (S)		C182	1-163-037-11	CERAMIC CHIP 0.022uF	10% 25V
		< CAPACITOR >		C183	1-163-038-00	CERAMIC CHIP 0.1uF	25V
C101	1-126-059-11	ELECT 10uF	20% 50V	C184	1-136-803-11	FILM 560PF	5% 630V
C102	1-164-695-11	CERAMIC CHIP 0.0022uF	5% 50V	C185	1-136-433-11	FILM 100PF	5% 630V
C103	1-164-695-11	CERAMIC CHIP 0.0022uF	5% 50V	C186	1-163-135-00	CERAMIC CHIP 560PF	5% 50V
C104	1-164-695-11	CERAMIC CHIP 0.0022uF	5% 50V	C201	1-126-059-11	ELECT 10uF	20% 50V
C105	1-137-195-91	FILM 0.56uF	5% 50V	C202	1-164-695-11	CERAMIC CHIP 0.0022uF	5% 50V
C106	1-136-171-00	FILM 0.33uF	5% 50V	C203	1-164-695-11	CERAMIC CHIP 0.0022uF	5% 50V
C107	1-126-059-11	ELECT 10uF	20% 50V	C204	1-164-695-11	CERAMIC CHIP 0.0022uF	5% 50V
C108	1-124-657-00	ELECT 10uF	20% 50V	C205	1-137-195-91	FILM 0.56uF	5% 50V
C121	1-163-127-00	CERAMIC CHIP 270PF	5% 50V	C206	1-136-171-00	FILM 0.33uF	5% 50V
C122	1-163-251-11	CERAMIC CHIP 100PF	5% 50V	C207	1-126-059-11	ELECT 10uF	20% 50V
C123	1-163-157-00	FILM 0.022uF	5% 50V	C208	1-124-657-00	ELECT 10uF	20% 50V
C124	1-124-657-00	ELECT 10uF	20% 50V	C221	1-163-127-00	CERAMIC CHIP 270PF	5% 50V
C125	1-163-986-00	CERAMIC CHIP 0.027uF	10% 25V	C222	1-163-251-11	CERAMIC CHIP 100PF	5% 50V
C126	1-164-693-11	CERAMIC CHIP 0.0018uF	5% 50V	C223	1-163-157-00	FILM 0.022uF	5% 50V
C127	1-163-239-91	CERAMIC CHIP 33PF	5% 50V	C224	1-124-657-00	ELECT 10uF	20% 50V
C128	1-164-693-11	CERAMIC CHIP 0.0018uF	5% 50V	C225	1-163-986-00	CERAMIC CHIP 0.027uF	10% 25V
C129	1-163-037-11	CERAMIC CHIP 0.022uF	10% 25V	C226	1-164-693-11	CERAMIC CHIP 0.0018uF	5% 50V
C131	1-164-695-11	CERAMIC CHIP 0.0022uF	5% 50V	C227	1-163-239-91	CERAMIC CHIP 33PF	5% 50V
C132	1-164-695-11	CERAMIC CHIP 0.0022uF	5% 50V	C228	1-164-693-11	CERAMIC CHIP 0.0018uF	5% 50V
C133	1-137-195-91	FILM 0.56uF	5% 50V	C229	1-163-037-11	CERAMIC CHIP 0.022uF	10% 25V
C134	1-136-171-00	FILM 0.33uF	5% 50V	C231	1-164-695-11	CERAMIC CHIP 0.0022uF	5% 50V
C135	1-124-657-00	ELECT 10uF	20% 50V	C232	1-164-695-11	CERAMIC CHIP 0.0022uF	5% 50V
C141	1-126-044-11	ELECT 1uF	20% 50V	C233	1-137-195-91	FILM 0.56uF	5% 50V
C142	1-126-059-11	ELECT 10uF	20% 50V	C234	1-136-171-00	FILM 0.33uF	5% 50V
C143	1-126-059-11	ELECT 10uF	20% 50V	C235	1-124-657-00	ELECT 10uF	20% 50V
				C241	1-126-044-11	ELECT 1uF	20% 50V
				C242	1-126-059-11	ELECT 10uF	20% 50V
				C243	1-126-059-11	ELECT 10uF	20% 50V
				C244	1-163-257-91	CERAMIC CHIP 180PF	5% 50V

## AUDIO SYSCON

Ref. No.	Part No.	Description	Remark	Ref. No.	Part No.	Description	Remark
C245	1-136-935-11	FILM 22PF	5% 630V	C802	1-163-038-00	CERAMIC CHIP 0.1uF	25V
C261	1-123-382-00	ELECT 3.3uF	20% 100V	C803	1-163-275-91	CERAMIC CHIP 0.001uF	5% 50V
C281	1-163-021-91	CERAMIC CHIP 0.01uF	10% 50V	C804	1-163-275-91	CERAMIC CHIP 0.001uF	5% 50V
C282	1-163-037-11	CERAMIC CHIP 0.022uF	10% 25V	C805	1-163-038-00	CERAMIC CHIP 0.1uF	25V
C283	1-163-038-00	CERAMIC CHIP 0.1uF	25V	C806	1-124-477-11	ELECT 47uF	20% 25V
C284	1-136-803-11	FILM 560PF	5% 630V	C807	1-126-176-11	ELECT 220uF	20% 10V
C285	1-136-433-11	FILM 100PF	5% 630V	C808	1-163-038-00	CERAMIC CHIP 0.1uF	25V
C286	1-163-135-00	CERAMIC CHIP 560PF	5% 50V	C809	1-124-927-11	ELECT 4.7uF	20% 100V
C501	1-126-022-11	ELECT 47uF	20% 25V	C810	1-163-038-00	CERAMIC CHIP 0.1uF	25V
C502	1-126-022-11	ELECT 47uF	20% 25V	C811	1-124-477-11	ELECT 47uF	20% 25V
C503	1-124-903-11	ELECT 1uF	20% 50V	C901	1-164-505-11	CERAMIC CHIP 2.2uF	16V
C521	1-124-994-11	ELECT 100uF	20% 10V	C902	1-163-275-91	CERAMIC CHIP 0.001uF	5% 50V
C522	1-124-994-11	ELECT 100uF	20% 10V	C903	1-163-038-00	CERAMIC CHIP 0.1uF	25V
C531	1-126-022-11	ELECT 47uF	20% 25V	C904	1-163-038-00	CERAMIC CHIP 0.1uF	25V
C532	1-126-022-11	ELECT 47uF	20% 25V	C905	1-164-505-11	CERAMIC CHIP 2.2uF	16V
C541	1-124-903-11	ELECT 1uF	20% 50V	C906	1-164-505-11	CERAMIC CHIP 2.2uF	16V
C542	1-126-233-11	ELECT 22uF	20% 50V			< CONNECTOR >	
C563	1-163-245-11	CERAMIC CHIP 56PF	5% 50V	CNP501 *	1-564-708-11	PIN, CONNECTOR (SMALL TYPE) 6P	
C564	1-163-037-11	CERAMIC CHIP 0.022uF	10% 25V	CNP503	1-564-722-11	PIN, CONNECTOR (SMALL TYPE) 6P	
C566	1-163-245-11	CERAMIC CHIP 56PF	5% 50V	CNP521 *	1-560-062-00	PIN, CONNECTOR 4P	
C567	1-124-927-11	ELECT 4.7uF	20% 100V	CNP541 *	1-560-062-00	PIN, CONNECTOR 4P	
C568	1-164-505-11	CERAMIC CHIP 2.2uF	16V	CNP581 *	1-560-060-00	PIN, CONNECTOR 2P	
C583	1-124-902-00	ELECT 0.47uF	20% 50V	CNP701 *	1-564-513-11	PLUG, CONNECTOR 10P	
C584	1-126-022-11	ELECT 47uF	20% 25V	CNP702 *	1-580-230-31	PIN, CONNECTOR (PC BOARD) 3P	
C585	1-126-022-11	ELECT 47uF	20% 25V	CNP704	1-568-226-11	PIN, CONNECTOR 2P	
C586	1-136-253-11	FILM 0.0018uF	5% 100V	CNP801 *	1-564-340-00	PIN, CONNECTOR 6P	
C587	1-136-253-11	FILM 0.0018uF	5% 100V	CNP802 *	1-564-342-61	PIN, CONNECTOR 8P	
C588	1-136-233-11	FILM 0.0047uF	5% 100V	CNP803 *	1-506-503-71	PIN, CONNECTOR 9P	
C589	1-163-037-11	CERAMIC CHIP 0.022uF	10% 25V	CNP804 *	1-564-708-11	PIN, CONNECTOR (SMALL TYPE) 6P	
C590	1-124-907-11	ELECT 10uF	20% 50V	CNP805	1-580-767-11	PIN, CONNECTOR (PC BOARD) 10P	
C591	1-107-045-00	MICA 3.9PF	500V	CNP901	1-506-468-11	CONNECTOR 3P, MALE	
C592	1-136-558-11	FILM 0.0039uF	5% 630V			< DIODE >	
C701	1-124-556-11	ELECT 2200uF	20% 16V	D161	8-719-988-62	DIODE 1SS355	
C702	1-124-556-11	ELECT 2200uF	20% 16V	D261	8-719-988-62	DIODE 1SS355	
C703	1-124-994-11	ELECT 100uF	20% 10V	D501	8-719-988-62	DIODE 1SS355	
C704	1-124-994-11	ELECT 100uF	20% 10V	D541	8-719-988-62	DIODE 1SS355	
C705	1-124-997-11	ELECT 470uF	20% 10V	D542	8-719-988-62	DIODE 1SS355	
C706	1-124-907-11	ELECT 10uF	20% 50V	D543	8-719-988-62	DIODE 1SS355	
C707	1-126-936-11	ELECT 3300uF	20% 16V	D544	8-719-988-62	DIODE 1SS355	
C709	1-124-907-11	ELECT 10uF	20% 50V	D561	8-719-988-62	DIODE 1SS355	
C710	1-124-471-00	ELECT 1000uF	20% 6.3V	D582	8-719-988-62	DIODE 1SS355	
C711	1-124-564-11	ELECT 4700uF	20% 25V	D583	8-719-988-62	DIODE 1SS355	
C712	1-124-907-11	ELECT 10uF	20% 50V	D584	8-719-988-62	DIODE 1SS355	
C713	1-124-360-00	ELECT 1000uF	20% 16V	D701	8-719-200-77	DIODE 10E2N	
C714	1-124-122-11	ELECT 100uF	20% 50V	D702	8-719-200-77	DIODE 10E2N	
C715	1-163-038-00	CERAMIC CHIP 0.1uF	25V	D703	8-719-200-77	DIODE 10E2N	
C716	1-124-910-11	ELECT 47uF	20% 50V	D704	8-719-200-77	DIODE 10E2N	
C717	1-161-744-00	CERAMIC 0.01uF	400V				
C801	1-163-038-00	CERAMIC CHIP 0.1uF	25V				

## AUDIO SYSCON

Ref. No.	Part No.	Description	Remark	Ref. No.	Part No.	Description	Remark
D705	8-719-933-33	DIODE	HZS6A1L	JR562	1-216-296-00	METAL CHIP	0 5% 1/8W
D706	8-719-933-33	DIODE	HZS6A1L	JR701	1-216-296-00	METAL CHIP	0 5% 1/8W
D707	8-719-312-09	DIODE	RBA-402	JR802	1-216-295-00	METAL CHIP	0 5% 1/10W
D711	8-719-988-62	DIODE	1SS355	JR803	1-216-295-00	METAL CHIP	0 5% 1/10W
D712	8-719-210-39	DIODE	EC10QS-04	JR804	1-216-295-00	METAL CHIP	0 5% 1/10W
D713	8-719-933-43	DIODE	HZS7A1L	JR901	1-216-295-00	METAL CHIP	0 5% 1/10W
D714	8-719-001-70	DIODE	UZL-12M1	JR902	1-216-296-00	METAL CHIP	0 5% 1/8W
D715	8-719-210-33	DIODE	EC10DS2	JR903	1-216-295-00	METAL CHIP	0 5% 1/10W
D716	8-719-210-33	DIODE	EC10DS2	JR904	1-216-296-00	METAL CHIP	0 5% 1/8W
D717	8-719-000-93	DIODE	UZL-7H1			< COIL >	
D801	8-719-988-62	DIODE	1SS355	L121	1-410-778-11	INDUCTOR	18mH
D802	8-719-988-62	DIODE	1SS355	L141	1-410-780-11	INDUCTOR	27mH
D803	8-719-988-62	DIODE	1SS355	L221	1-410-778-11	INDUCTOR	18mH
D805	8-719-210-33	DIODE	EC10DS2	L241	1-410-780-11	INDUCTOR	27mH
D806	8-719-933-33	DIODE	HZS6A1L			< FILTER >	
D807	8-719-933-33	DIODE	HZS6A1L	LPF101	1-236-147-11	FILTER, LOW PASS	
D901	8-719-301-44	DIODE	SEL2410E-D	LPF201	1-236-147-11	FILTER, LOW PASS	
		< INDICATOR >				< TRANSISTOR >	
FL901	1-519-680-11	INDICATOR TUBE, FLUORESCENT		Q101	8-729-805-41	TRANSISTOR	2SC3398
		< IC >		Q102	8-729-921-73	TRANSISTOR	2SD1781K-QR
IC501	8-752-037-90	IC	CXA1331M	Q121	8-729-805-40	TRANSISTOR	2SC3900
IC502	8-759-516-47	IC	CD4066BCM	Q141	8-729-921-73	TRANSISTOR	2SD1781K-QR
IC521	8-759-111-44	IC	uPC4570C-1	Q201	8-729-805-41	TRANSISTOR	2SC3398
IC531	8-752-037-90	IC	CXA1331M	Q202	8-729-921-73	TRANSISTOR	2SD1781K-QR
IC541	8-752-038-02	IC	CXA1198AP	Q221	8-729-805-40	TRANSISTOR	2SC3900
IC561	8-759-981-95	IC	RC4558S	Q241	8-729-921-73	TRANSISTOR	2SD1781K-QR
IC562	8-759-981-95	IC	RC4558S	Q501	8-729-805-41	TRANSISTOR	2SC3398
IC581	8-759-106-56	IC	uPC1297CA	Q502	8-729-805-65	TRANSISTOR	2SA1344
IC701	8-759-981-95	IC	RC4558S	Q503	8-729-805-65	TRANSISTOR	2SA1344
IC801	8-759-637-18	IC	M50964-255FP	Q504	8-729-805-65	TRANSISTOR	2SA1344
IC802	8-759-822-09	IC	LB1641	Q541	8-729-805-45	TRANSISTOR	2SC3395
IC803	8-759-973-95	IC	BA6219B	Q542	8-729-805-45	TRANSISTOR	2SC3395
IC804	8-759-516-49	IC	CD4069BCM-FL63	Q543	8-729-805-45	TRANSISTOR	2SC3395
IC805	8-759-822-09	IC	LB1641	Q561	8-729-602-36	TRANSISTOR	2SA1602
IC901	8-759-637-17	IC	M50940-334FP	Q581	8-729-821-04	TRANSISTOR	2SA1317-STU
IC902	8-741-100-48	IC	SBX1610-59	Q582	8-729-805-41	TRANSISTOR	2SC3398
		< JACK >		Q583	8-729-805-41	TRANSISTOR	2SC3398
J501	1-573-070-11	JACK, PIN 4P (LINE IN/OUT)		Q584	8-729-805-41	TRANSISTOR	2SC3398
		< JUMPER >		Q585	8-729-194-57	TRANSISTOR	2SC945-P
JR131	1-216-296-00	METAL CHIP	0 5% 1/8W	Q586	8-729-194-57	TRANSISTOR	2SC945-P
JR141	1-216-296-00	METAL CHIP	0 5% 1/8W	Q701	8-729-924-90	TRANSISTOR	2SB1370-EF
JR231	1-216-296-00	METAL CHIP	0 5% 1/8W	Q702	8-729-111-55	TRANSISTOR	2SD1312K
JR241	1-216-296-00	METAL CHIP	0 5% 1/8W	Q703	8-729-602-21	TRANSISTOR	2SC4154
JR561	1-216-296-00	METAL CHIP	0 5% 1/8W	Q704	8-729-111-55	TRANSISTOR	2SD1312K
				Q705	8-729-924-90	TRANSISTOR	2SB1370-EF
				Q706	8-729-602-21	TRANSISTOR	2SC4154

## AUDIO SYSCON

Ref. No.	Part No.	Description	Remark	Ref. No.	Part No.	Description	Remark
Q707	8-729-602-36	TRANSISTOR	2SA1602	R146	1-216-065-00	METAL CHIP	4.7K 5% 1/10W
Q708	8-729-140-04	TRANSISTOR	2SB1116A-L	R161	1-216-086-00	METAL GLAZE	36K 5% 1/10W
Q801	8-729-602-36	TRANSISTOR	2SA1602	R162	1-216-086-00	METAL GLAZE	36K 5% 1/10W
Q802	8-729-602-36	TRANSISTOR	2SA1602	R163	1-216-088-00	METAL CHIP	43K 5% 1/10W
Q803	8-729-602-36	TRANSISTOR	2SA1602	R164	1-249-409-11	CARBON	220 5% 1/4W
Q804	8-729-805-65	TRANSISTOR	2SA1344	R181	1-216-079-00	METAL CHIP	18K 5% 1/10W
Q805	8-729-805-65	TRANSISTOR	2SA1344	R182	1-216-085-00	METAL CHIP	33K 5% 1/10W
Q806	8-729-805-65	TRANSISTOR	2SA1344	R183	1-216-001-00	METAL CHIP	10 5% 1/10W
Q807	8-729-805-65	TRANSISTOR	2SA1344	R184	1-216-101-00	METAL CHIP	150K 5% 1/10W
Q808	8-729-805-65	TRANSISTOR	2SA1344	R201	1-249-433-11	CARBON	22K 5% 1/4W
Q811	8-729-602-21	TRANSISTOR	2SC4154	R202	1-216-105-00	METAL CHIP	220K 5% 1/10W
Q812	8-729-602-21	TRANSISTOR	2SC4154	R204	1-216-061-00	METAL CHIP	3.3K 5% 1/10W
Q901	8-729-805-65	TRANSISTOR	2SA1344	R205	1-216-071-00	METAL CHIP	8.2K 5% 1/10W
Q902	8-729-805-65	TRANSISTOR	2SA1344	R206	1-216-082-00	METAL GLAZE	24K 5% 1/10W
Q903	8-729-805-65	TRANSISTOR	2SA1344	R207	1-216-043-00	METAL CHIP	560 5% 1/10W
Q904	8-729-805-65	TRANSISTOR	2SA1344	R208	1-216-097-00	METAL CHIP	100K 5% 1/10W
Q905	8-729-805-65	TRANSISTOR	2SA1344	R209	1-216-057-00	METAL CHIP	2.2K 5% 1/10W
Q907	8-729-805-65	TRANSISTOR	2SA1344	R210	1-216-057-00	METAL CHIP	2.2K 5% 1/10W
		< RESISTOR >		R211	1-216-073-00	METAL CHIP	10K 5% 1/10W
R101	1-249-433-11	CARBON	22K 5% 1/4W	R212	1-249-417-11	CARBON	1K 5% 1/4W
R102	1-216-105-00	METAL CHIP	220K 5% 1/10W	R213	1-216-049-00	METAL CHIP	1K 5% 1/10W
R104	1-216-061-00	METAL CHIP	3.3K 5% 1/10W	R221	1-216-097-00	METAL CHIP	100K 5% 1/10W
R105	1-216-071-00	METAL CHIP	8.2K 5% 1/10W	R222	1-216-025-00	METAL CHIP	100 5% 1/10W
R106	1-216-082-00	METAL GLAZE	24K 5% 1/10W	R223	1-216-100-00	METAL GLAZE	130K 5% 1/10W
R107	1-216-043-00	METAL CHIP	560 5% 1/10W	R224	1-216-067-00	METAL CHIP	5.6K 5% 1/10W
R108	1-216-097-00	METAL CHIP	100K 5% 1/10W	R225	1-216-055-00	METAL CHIP	1.8K 5% 1/10W
R109	1-216-057-00	METAL CHIP	2.2K 5% 1/10W	R226	1-216-056-00	METAL GLAZE	2K 5% 1/10W
R110	1-216-057-00	METAL CHIP	2.2K 5% 1/10W	R227	1-216-105-00	METAL CHIP	220K 5% 1/10W
R111	1-216-073-00	METAL CHIP	10K 5% 1/10W	R228	1-216-057-00	METAL CHIP	2.2K 5% 1/10W
R112	1-249-417-11	CARBON	1K 5% 1/4W	R229	1-216-057-00	METAL CHIP	2.2K 5% 1/10W
R113	1-216-049-00	METAL CHIP	1K 5% 1/10W	R234	1-216-082-00	METAL GLAZE	24K 5% 1/10W
R121	1-216-097-00	METAL CHIP	100K 5% 1/10W	R235	1-216-043-00	METAL CHIP	560 5% 1/10W
R122	1-216-025-00	METAL CHIP	100 5% 1/10W	R237	1-216-097-00	METAL CHIP	100K 5% 1/10W
R123	1-216-100-00	METAL GLAZE	130K 5% 1/10W	R241	1-216-067-00	METAL CHIP	5.6K 5% 1/10W
R124	1-216-067-00	METAL CHIP	5.6K 5% 1/10W	R242	1-216-058-00	METAL GLAZE	2.4K 5% 1/10W
R125	1-216-055-00	METAL CHIP	1.8K 5% 1/10W	R243	1-216-057-00	METAL CHIP	2.2K 5% 1/10W
R126	1-216-056-00	METAL GLAZE	2K 5% 1/10W	R244	1-216-073-00	METAL CHIP	10K 5% 1/10W
R127	1-216-105-00	METAL CHIP	220K 5% 1/10W	R245	1-216-073-00	METAL CHIP	10K 5% 1/10W
R128	1-216-057-00	METAL CHIP	2.2K 5% 1/10W	R246	1-216-065-00	METAL CHIP	4.7K 5% 1/10W
R129	1-216-057-00	METAL CHIP	2.2K 5% 1/10W	R261	1-216-086-00	METAL GLAZE	36K 5% 1/10W
R134	1-216-082-00	METAL GLAZE	24K 5% 1/10W	R262	1-216-086-00	METAL GLAZE	36K 5% 1/10W
R135	1-216-043-00	METAL CHIP	560 5% 1/10W	R263	1-216-088-00	METAL CHIP	43K 5% 1/10W
R137	1-216-097-00	METAL CHIP	100K 5% 1/10W	R264	1-249-409-11	CARBON	220 5% 1/4W
R141	1-216-067-00	METAL CHIP	5.6K 5% 1/10W	R281	1-216-079-00	METAL CHIP	18K 5% 1/10W
R142	1-216-058-00	METAL GLAZE	2.4K 5% 1/10W	R282	1-216-085-00	METAL CHIP	33K 5% 1/10W
R143	1-216-057-00	METAL CHIP	2.2K 5% 1/10W	R283	1-216-001-00	METAL CHIP	10 5% 1/10W
R144	1-216-073-00	METAL CHIP	10K 5% 1/10W	R284	1-216-101-00	METAL CHIP	150K 5% 1/10W
R145	1-216-073-00	METAL CHIP	10K 5% 1/10W	R501	1-216-049-00	METAL CHIP	1K 5% 1/10W
				R502	1-215-455-00	METAL	27K 1% 1/6W

## AUDIO SYSCON

Ref. No.	Part No.	Description	Remark			Ref. No.	Part No.	Description	Remark		
R503	1-216-089-00	METAL CHIP	47K	5%	1/10W	R618	1-216-104-00	METAL CHIP	200K	5%	1/10W
R504	1-216-061-00	METAL CHIP	3.3K	5%	1/10W	R701	1-249-426-11	CARBON	5.6K	5%	1/4W
R505	1-216-081-00	METAL CHIP	22K	5%	1/10W	R702	1-249-425-11	CARBON	4.7K	5%	1/4W
R521	1-247-704-11	CARBON	220	5%	1/4W	R703	1-216-069-00	METAL CHIP	6.8K	5%	1/10W
R522	1-247-704-11	CARBON	220	5%	1/4W	R704	1-216-053-00	METAL CHIP	1.5K	5%	1/10W
R531	1-216-049-00	METAL CHIP	1K	5%	1/10W	R705	1-216-073-00	METAL CHIP	10K	5%	1/10W
R532	1-215-455-00	METAL	27K	1%	1/6W	R706	1-216-053-00	METAL CHIP	1.5K	5%	1/10W
R533	1-249-409-11	CARBON	220	5%	1/4W	R707	1-216-069-00	METAL CHIP	6.8K	5%	1/10W
R541	1-216-097-00	METAL CHIP	100K	5%	1/10W	R708	1-249-425-11	CARBON	4.7K	5%	1/4W
R542	1-216-049-00	METAL CHIP	1K	5%	1/10W	R709	1-216-033-00	METAL CHIP	220	5%	1/10W
R543	1-215-454-00	METAL	24K	1%	1/6W	R710	1-216-049-00	METAL CHIP	1K	5%	1/10W
R544	1-216-081-00	METAL CHIP	22K	5%	1/10W	R711	1-216-069-00	METAL CHIP	6.8K	5%	1/10W
R563	1-216-097-00	METAL CHIP	100K	5%	1/10W	R712	△ 1-219-137-11	FUSIBLE	0.33	10%	1/4W
R564	1-216-073-00	METAL CHIP	10K	5%	1/10W	R713	△ 1-219-135-11	FUSIBLE	0.15	10%	1/4W
R565	1-216-097-00	METAL CHIP	100K	5%	1/10W	R714	1-249-417-11	CARBON	1K	5%	1/4W
R566	1-216-071-00	METAL CHIP	8.2K	5%	1/10W	R715	1-216-065-00	METAL CHIP	4.7K	5%	1/10W
R567	1-216-097-00	METAL CHIP	100K	5%	1/10W	R716	1-249-425-11	CARBON	4.7K	5%	1/4W
R568	1-216-061-00	METAL CHIP	3.3K	5%	1/10W	R717	1-249-437-11	CARBON	47K	5%	1/4W
R569	1-216-097-00	METAL CHIP	100K	5%	1/10W	R718	1-216-081-00	METAL CHIP	22K	5%	1/10W
R570	1-216-073-00	METAL CHIP	10K	5%	1/10W	R719	1-216-084-00	METAL CHIP	30K	5%	1/10W
R571	1-216-073-00	METAL CHIP	10K	5%	1/10W	R720	1-216-071-00	METAL CHIP	8.2K	5%	1/10W
R572	1-216-049-00	METAL CHIP	1K	5%	1/10W	R801	△ 1-212-952-00	FUSIBLE	5.6	5%	1/2W F
R581	1-216-073-00	METAL CHIP	10K	5%	1/10W	R802	△ 1-212-954-11	FUSIBLE	6.8	5%	1/2W F
R582	1-216-073-00	METAL CHIP	10K	5%	1/10W	R803	1-216-069-00	METAL CHIP	6.8K	5%	1/10W
R583	1-216-055-00	METAL CHIP	1.8K	5%	1/10W	R804	1-216-071-00	METAL CHIP	8.2K	5%	1/10W
R584	1-216-066-00	METAL CHIP	5.1K	5%	1/10W	R805	1-216-071-00	METAL CHIP	8.2K	5%	1/10W
R585	1-216-085-00	METAL CHIP	33K	5%	1/10W	R806	1-216-073-00	METAL CHIP	10K	5%	1/10W
R586	1-216-066-00	METAL CHIP	5.1K	5%	1/10W	R807	1-216-072-00	METAL CHIP	9.1K	5%	1/10W
R587	1-216-095-00	METAL CHIP	82K	5%	1/10W	R808	1-216-068-00	METAL CHIP	6.2K	5%	1/10W
R588	1-216-095-00	METAL CHIP	82K	5%	1/10W	R809	1-216-053-00	METAL CHIP	1.5K	5%	1/10W
R589	1-249-390-11	CARBON	5.6	5%	1/6W	R810	1-216-105-00	METAL CHIP	220K	5%	1/10W
R590	1-249-390-11	CARBON	5.6	5%	1/6W	R811	1-216-105-00	METAL CHIP	220K	5%	1/10W
R601	1-216-094-00	METAL GLAZE	75K	5%	1/10W	R812	1-216-748-11	METAL CHIP	39K	1%	1/10W
R602	1-216-085-00	METAL CHIP	33K	5%	1/10W	R813	1-216-748-11	METAL CHIP	39K	1%	1/10W
R603	1-216-088-00	METAL CHIP	43K	5%	1/10W	R814	1-216-089-00	METAL CHIP	47K	5%	1/10W
R604	1-216-093-00	METAL CHIP	68K	5%	1/10W	R815	1-216-089-00	METAL CHIP	47K	5%	1/10W
R605	1-216-096-00	METAL GLAZE	91K	5%	1/10W	R816	1-216-089-00	METAL CHIP	47K	5%	1/10W
R606	1-216-081-00	METAL CHIP	22K	5%	1/10W	R817	1-216-089-00	METAL CHIP	47K	5%	1/10W
R607	1-216-093-00	METAL CHIP	68K	5%	1/10W	R818	1-216-089-00	METAL CHIP	47K	5%	1/10W
R608	1-216-089-00	METAL CHIP	47K	5%	1/10W	R819	1-216-089-00	METAL CHIP	47K	5%	1/10W
R609	1-216-097-00	METAL CHIP	100K	5%	1/10W	R820	1-216-089-00	METAL CHIP	47K	5%	1/10W
R610	1-216-092-00	METAL GLAZE	62K	5%	1/10W	R821	△ 1-212-952-00	FUSIBLE	5.6	5%	1/2W F
R611	1-216-096-00	METAL GLAZE	91K	5%	1/10W	R822	1-216-067-00	METAL CHIP	5.6K	5%	1/10W
R612	1-216-105-00	METAL CHIP	220K	5%	1/10W	R823	1-216-057-00	METAL CHIP	2.2K	5%	1/10W
R613	1-216-094-00	METAL GLAZE	75K	5%	1/10W	R825	1-216-081-00	METAL CHIP	22K	5%	1/10W
R614	1-216-090-00	METAL CHIP	51K	5%	1/10W	R826	1-216-075-00	METAL CHIP	12K	5%	1/10W
R615	1-216-104-00	METAL CHIP	200K	5%	1/10W	R827	1-216-085-00	METAL CHIP	33K	5%	1/10W
R616	1-216-092-00	METAL GLAZE	62K	5%	1/10W	R828	1-216-090-00	METAL CHIP	51K	5%	1/10W
R617	1-216-092-00	METAL GLAZE	62K	5%	1/10W	R829	1-216-073-00	METAL CHIP	10K	5%	1/10W

Note: The components identified by mark △ or dotted line with mark △ are critical for safety. Replace only with part number specified.

## AUDIO SYSCON

Ref. No.	Part No.	Description			Remark	Ref. No.	Part No.	Description			Remark
R830	1-216-085-00	METAL CHIP	33K	5%	1/10W	R923	1-216-025-00	METAL CHIP	100	5%	1/10W
R831	1-216-121-00	METAL CHIP	1M	5%	1/10W	R924	1-216-025-00	METAL CHIP	100	5%	1/10W
R832	1-216-089-00	METAL CHIP	47K	5%	1/10W	R925	1-216-025-00	METAL CHIP	100	5%	1/10W
R833	1-216-085-00	METAL CHIP	33K	5%	1/10W	R926	1-216-025-00	METAL CHIP	100	5%	1/10W
R834	1-216-085-00	METAL CHIP	33K	5%	1/10W	R927	1-216-057-00	METAL CHIP	2.2K	5%	1/10W
R835	1-216-065-00	METAL CHIP	4.7K	5%	1/10W	R928	1-216-057-00	METAL CHIP	2.2K	5%	1/10W
R836	1-216-049-00	METAL CHIP	1K	5%	1/10W	R929	1-216-057-00	METAL CHIP	2.2K	5%	1/10W
R837	1-216-089-00	METAL CHIP	47K	5%	1/10W	R930	1-216-057-00	METAL CHIP	2.2K	5%	1/10W
R838	1-216-089-00	METAL CHIP	47K	5%	1/10W	R932	1-216-057-00	METAL CHIP	2.2K	5%	1/10W
R839	1-216-089-00	METAL CHIP	47K	5%	1/10W						
R840	$\Delta$ 1-212-942-00	FUSIBLE	2.2	5%	1/2W F			< VARIABLE RESISTOR >			
R841	1-216-025-00	METAL CHIP	100	5%	1/10W	RV121	1-237-458-21	RES. ADJ. CARBON 5K (PB LEVEL)			
R842	1-216-025-00	METAL CHIP	100	5%	1/10W	RV141	1-237-460-11	RES. ADJ. CARBON 20K (REC GAIN)			
R843	1-216-025-00	METAL CHIP	100	5%	1/10W	RV181	1-238-601-11	RES. ADJ. CARBON 22K (BIAS)			
R844	1-216-025-00	METAL CHIP	100	5%	1/10W	RV221	1-237-458-21	RES. ADJ. CARBON 5K (PB LEVEL)			
R845	1-216-025-00	METAL CHIP	100	5%	1/10W	RV241	1-237-460-11	RES. ADJ. CARBON 20K (REC GAIN)			
R846	1-216-089-00	METAL CHIP	47K	5%	1/10W	RV281	1-238-601-11	RES. ADJ. CARBON 22K (BIAS)			
R847	1-216-089-00	METAL CHIP	47K	5%	1/10W	RV501	1-241-615-11	RES. VAR. CARBON 50K/50K (REC LEVEL)			
R848	1-216-089-00	METAL CHIP	47K	5%	1/10W	RV502	1-241-616-11	RES. VAR. CARBON 50K/50K (BALANCE)			
R849	1-216-065-00	METAL CHIP	4.7K	5%	1/10W			< SWITCH >			
R850	1-216-065-00	METAL CHIP	4.7K	5%	1/10W	S701	$\Delta$ 1-572-267-51	SWITCH, PUSH (AC POWER) (1 KEY)			
R851	1-216-065-00	METAL CHIP	4.7K	5%	1/10W	S801	1-572-859-11	SWITCH, SLIDE (MPX FILTER)			
R852	1-216-065-00	METAL CHIP	4.7K	5%	1/10W	S802	1-572-143-11	SWITCH, SLIDE (OUT DETECT)			
R853	1-216-065-00	METAL CHIP	4.7K	5%	1/10W	S803	1-572-143-11	SWITCH, SLIDE (IN DETECT)			
R854	1-216-065-00	METAL CHIP	4.7K	5%	1/10W	S901	1-554-303-21	SWITCH, TACTILE (RESET)			
R855	1-216-089-00	METAL CHIP	47K	5%	1/10W	S902	1-554-303-21	SWITCH, TACTILE (MEMORY)			
R856	1-216-062-00	METAL CHIP	3.6K	5%	1/10W	S903	1-554-303-21	SWITCH, TACTILE (TAPE/SOURCE)			
R901	1-216-097-00	METAL CHIP	100K	5%	1/10W	S904	1-554-303-21	SWITCH, TACTILE (▷)			
R902	1-216-097-00	METAL CHIP	100K	5%	1/10W	S905	1-554-303-21	SWITCH, TACTILE (▮)			
R903	1-216-097-00	METAL CHIP	100K	5%	1/10W	S906	1-554-303-21	SWITCH, TACTILE (◉)			
R904	1-216-097-00	METAL CHIP	100K	5%	1/10W	S907	1-554-303-21	SWITCH, TACTILE (△)			
R905	1-216-097-00	METAL CHIP	100K	5%	1/10W	S908	1-554-303-21	SWITCH, TACTILE (□)			
R906	1-216-121-00	METAL CHIP	1M	5%	1/10W	S909	1-554-303-21	SWITCH, TACTILE (◁)			
R907	1-249-408-11	CARBON	180	5%	1/4W	S910	1-554-303-21	SWITCH, TACTILE (▷▷)			
R908	1-216-059-00	METAL CHIP	2.7K	5%	1/10W	S911	1-554-303-21	SWITCH, TACTILE (●)			
R909	1-216-063-00	METAL CHIP	3.9K	5%	1/10W	S912	1-570-835-11	SWITCH, SLIDE (DOLBY NR)			
R910	1-216-059-00	METAL CHIP	2.7K	5%	1/10W			< TRANSFORMER >			
R911	1-216-063-00	METAL CHIP	3.9K	5%	1/10W	T181	1-433-344-11	TRANSFORMER, BIAS OSCILLATION			
R912	1-216-059-00	METAL CHIP	2.7K	5%	1/10W	T281	1-433-344-11	TRANSFORMER, BIAS OSCILLATION			
R913	1-216-063-00	METAL CHIP	3.9K	5%	1/10W	T581	1-433-343-11	TRANSFORMER, BIAS OSCILLATION			
R914	1-216-071-00	METAL CHIP	8.2K	5%	1/10W			< TEST PIN >			
R915	1-216-083-00	METAL CHIP	27K	5%	1/10W	TP581	* 1-564-506-11	PLUG, CONNECTOR 3P			
R916	1-216-059-00	METAL CHIP	2.7K	5%	1/10W	TP801	* 1-564-506-11	PLUG, CONNECTOR 3P			
R917	1-216-073-00	METAL CHIP	10K	5%	1/10W	TP802	* 1-564-505-11	PLUG, CONNECTOR 2P			
R918	1-216-073-00	METAL CHIP	10K	5%	1/10W	TP803	* 1-564-505-11	PLUG, CONNECTOR 2P			
R919	1-216-073-00	METAL CHIP	10K	5%	1/10W						
R920	1-216-073-00	METAL CHIP	10K	5%	1/10W						
R921	1-216-085-00	METAL CHIP	33K	5%	1/10W						
R922	1-216-025-00	METAL CHIP	100	5%	1/10W						

Note: The components identified by mark  $\Delta$  or dotted line with mark  $\Delta$  are critical for safety. Replace only with part number specified.

**AUDIO SYSCON MD REEL MOTOR**

Ref. No.	Part No.	Description	Remark
		< VIBRATOR, CERAMIC >	
X801	1-577-358-21	VIBRATOR, CERAMIC (4MHz)	
X901	1-577-358-21	VIBRATOR, CERAMIC (4MHz)	
*****			
	* 1-632-740-11	MD BOARD	
		*****	
	3-356-631-01	HOLDER (SENSOR)	
		< CONNECTOR >	
CN1001	1-506-615-11	PIN, CONNECTOR 9P	
CN1002	1-564-501-11	PIN, CONNECTOR 8P	
		< IC >	
IC1001	8-749-920-97	DIODE GP2S22B	
IC1002	8-749-920-97	DIODE GP2S22B	
		< RESISTOR >	
R1001	1-249-408-11	CARBON 180 5% 1/4W	
R1002	1-249-408-11	CARBON 180 5% 1/4W	
		< SWITCH >	
S1003	1-571-958-11	SWITCH, PUSH (1 KEY) (CLOSE)	
S1004	1-572-126-11	SWITCH, PUSH (1 KEY) (OPEN)	
S1005	1-572-125-11	SWITCH, LEAF (REC)	
S1006	1-572-202-11	SWITCH, LEAF (HALF)	
S1007	1-572-125-11	SWITCH, LEAF (METAL)	
S1008	1-572-125-11	SWITCH, LEAF (70uS)	
		< CONNECTOR >	
TB1001	* 1-569-066-11	PIN, CONNECTOR 5P	
*****			
	* 1-632-741-11	REEL MOTOR BOARD	
		*****	
		< CAPACITOR >	
C1051	1-124-907-11	ELECT 10uF 20% 50V	
C1052	1-124-907-11	ELECT 10uF 20% 50V	
C1053	1-164-159-11	CERAMIC 0.1uF 50V	
		< CONNECTOR >	
CN1051	* 1-564-499-11	PIN, CONNECTOR 6P	
CN1052	* 1-564-718-11	PIN, CONNECTOR (SMALL TYPE) 2P	

Ref. No.	Part No.	Description	Remark
		MISCELLANEOUS	
		*****	
61	△ 1-558-946-21	CORD, POWER (UK)	
61	△ 1-575-651-21	CORD, POWER (AEP, G)	
61	△ 1-590-836-11	CORD, POWER (US, Canadian)	
157	1-543-535-11	HEAD, MAGNETIC (ERASE)	
158	1-543-733-11	HEAD, MAGNETIC (RECORD/PLAYBACK)	
228	1-466-238-11	ENCODER, ROTARY	
PT701	△ 1-450-631-11	TRANSFORMER, POWER (AEP, UK, G)	
PT701	△ 1-450-630-11	TRANSFORMER, POWER (US, Canadian)	
*****			
		ACCESSORIES & PACKING MATERIALS	
		*****	
		1-558-271-11	CORD, CONNECTION
		1-559-533-11	CORD, CONNECTION
	* 3-371-941-01	CUSHION	
	* 3-371-942-01	INDIVIDUAL CARTON	
	* 3-704-343-01	SHEET (STANDARD), PROTECTION	
		3-753-815-11	MANUAL, INSTRUCTION (ENGLISH, FRENCH, SPANISH, PORTUGUESE) (AEP, UK)
		3-753-815-41	MANUAL, INSTRUCTION (GERMAN, DUCH, SWEDISH, ITALIAN) (AEP, G)
*****			
<b>HARDWARE LIST</b>			
*****			
#1	7-621-255-35	SCREW +BVTT 2X5 (S)	
#2	7-621-772-20	SCREW +B 2X5	
#3	7-621-775-10	SCREW +B 2.6X4	
#4	7-621-849-00	SCREW (BV/RING)	
#5	7-682-547-04	SCREW +BVTT 3X6 (S)	
#6	7-682-548-09	SCREW +BVTT 3X8 (S)	
#7	7-685-106-19	SCREW +P 2X10 TYPE2 NON-SLIT	
#8	7-685-132-19	SCREW +BTP 2.6X5 TYPE2 N-S	
#9	7-685-133-19	SCREW +BTP 2.6X6 TYPE2 N-S	

Note: The components identified by mark △ or dotted line with mark △ are critical for safety. Replace only with part number specified.