

TC-W230/W233/W235

SERVICE MANUAL

TC-W230:

*US Model
Canadian Model
AEP Model
UK Model
E Model*

TC-W233:

US Model

TC-W235:

E Model

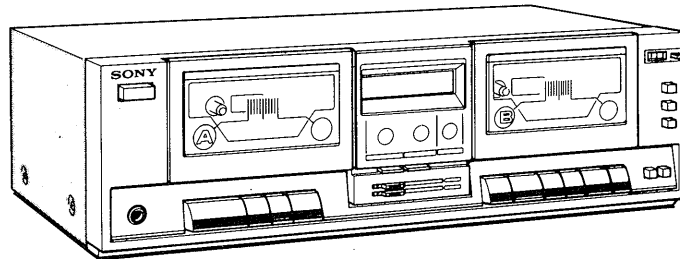

'Dolby' and the double-D symbol are the trade marks of Dolby laboratories Licensing Corporation. Noise reduction system manufactured under license from Dolby Laboratories Licensing Corporation.

SPECIFICATIONS

Tape Transport Mechanism Type	DECK A	TCM-54FMF
	DECK B	TCM-53FMF

Recording system 4-track 2-channel stereo
Fast-forward and rewind time
Approx. 105 sec. (with HF-60 cassette)
Bias frequency 105 kHz
Signal-to-noise ratio (NAB, at peak level)

Cassette	Dolby NR switch		
	OFF	B TYPE ON	C TYPE ON
TYPE IV (Sony METAL-ES)	58 dB	65 dB	71 dB
TYPE II (Sony UCX-S)	56 dB	63 dB	69 dB
TYPE I (Sony HF-S)	54 dB	61 dB	67 dB

Total harmonic distortion
1.0% (with Sony METAL-ES cassettes)

SAFETY-RELATED COMPONENT WARNING!!

COMPONENTS IDENTIFIED BY SHADING AND MARK  ON THE SCHEMATIC DIAGRAMS AND IN THE PARTS LIST ARE CRITICAL TO SAFE OPERATION. REPLACE THESE COMPONENTS WITH SONY PARTS WHOSE PART NUMBERS APPEAR AS SHOWN IN THIS MANUAL OR IN SUPPLEMENTS PUBLISHED BY SONY.

ATTENTION AU COMPOSANT AYANT RAPPORT À LA SÉCURITÉ!

LES COMPOSANTS IDENTIFIÉS PAR UNE TRAME ET UNE MARQUE  SUR LES DIAGRAMMES SCHEMATIQUES ET LA LISTE DES PIÈCES SONT CRITIQUES POUR LA SÉCURITÉ DE FONCTIONNEMENT. NE REMPLACER CES COMPOSANTS QUE PAR DES PIÈCES SONY DONT LES NUMÉROS SONT DONNÉS DANS CE MANUEL OU DANS LES SUPPLÉMENTS PUBLIÉS PAR SONY.

Frequency response

DOLBY NR OFF

- With TYPE IV cassette (Sony METAL-ES)
30–15,000 Hz (± 3 dB)
30–13,000 Hz (± 3 dB, 0 VU recording)
30–15,000 Hz (DIN)
- With TYPE II cassette (Sony UCX-S)
30–14,000 Hz (± 3 dB)
30–14,000 Hz (DIN)
- With TYPE I cassette (Sony HF-S)
30–13,000 Hz (± 3 dB)
30–13,000 Hz (DIN)

Wow and flutter

0.12% WRMS (NAB)
 $\pm 0.18\%$ (IEC)

Inputs

Line inputs (phono jacks)
Sensitivity 77.5 mV (-20 dB)
Input impedance 47 kilohms

Outputs

Line outputs (phono jacks)
Output level 0.44 V (-5 dB) at load impedance 47 kilohms
Load impedance over 10 kilohms
Headphone output (stereo phone jack)
Output level -28 dB at a load impedance of 8 ohms

0 dB = 0.775 V

— Continued on page 2 —

STEREO CASSETTE DECK
SONY[®]

TC



使用時は添付資料も参照のこと
Refer to the additional documents.

General

Power requirements

US, Canadian model: 120 V ac, 50 Hz
 AEP model: 220 V ac, 50 Hz
 (240 V ac adjustable by authorized Sony personnel)
 UK model: 240 V ac, 50 Hz
 (220 V ac adjustable by authorized Sony personnel)
 E model: 120, 220 or 240 V ac adjustable, 50/60 Hz

Power consumption

20 watts

Dimensions

Approx. 430 × 130 × 250 mm (w/h/d)
 (17 × 5 1/8 × 9 7/8 inches)

Weight

including projecting parts and controls
 Approx. 4.5 kg (9 lbs 15 oz)

MODEL IDENTIFICATION

— *specification Label* —

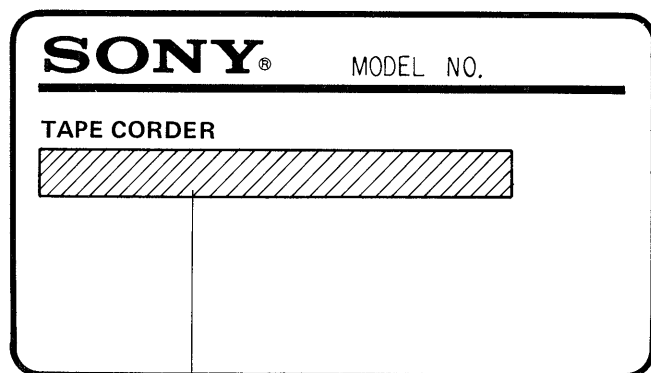

US, Canadian model: AC: 120 V 60 Hz 20 W
 AEP model: AC: 220 V 50/60 Hz 20 W
 UK model: AC: 240 V 50 Hz 20 W
 E model: AC: 120, 220, 240 V 50/60 Hz 20 W

SAFETY CHECK-OUT (US Model)

After correcting the original service problem, perform the following safety check before releasing the set to the customer:

Check the antenna terminals, metal trim, “metallized” knobs, screws, and all other exposed metal parts for AC leakage. Check leakage as described below.

LEAKAGE TEST

The AC leakage from any exposed metal part to earth ground and from all exposed metal parts to any exposed metal part having a return to chassis, must not exceed 0.5 mA (500 microampers). Leakage current can be measured by any one of three methods.

1. A commercial leakage tester, such as the Simpson 229 or RCA WT-540A. Follow the manufacturers' instructions to use these instruments.
2. A battery-operated AC milliammeter. The Data Precision 245 digital multimeter is suitable for this job.
3. Measuring the voltage drop across a resistor by means of a VOM or battery-operated AC voltmeter. The “limit” indication is 0.75 V, so analog meters must have an accurate low-voltage scale. The Simpson 250 and Sanwa SH-63Trd are examples of a passive VOM that is suitable. Nearly all battery operated digital multimeters that have a 2 V AC range are suitable. (See Fig. A)

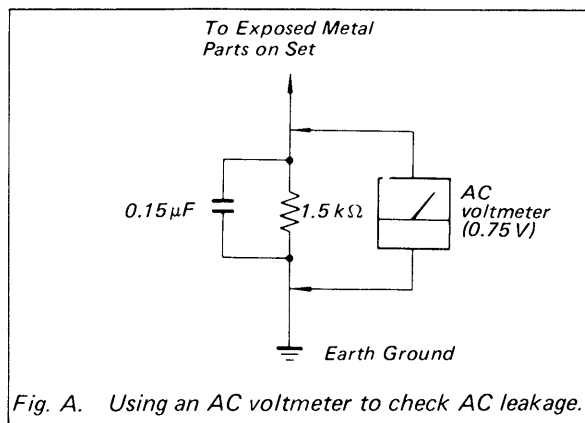
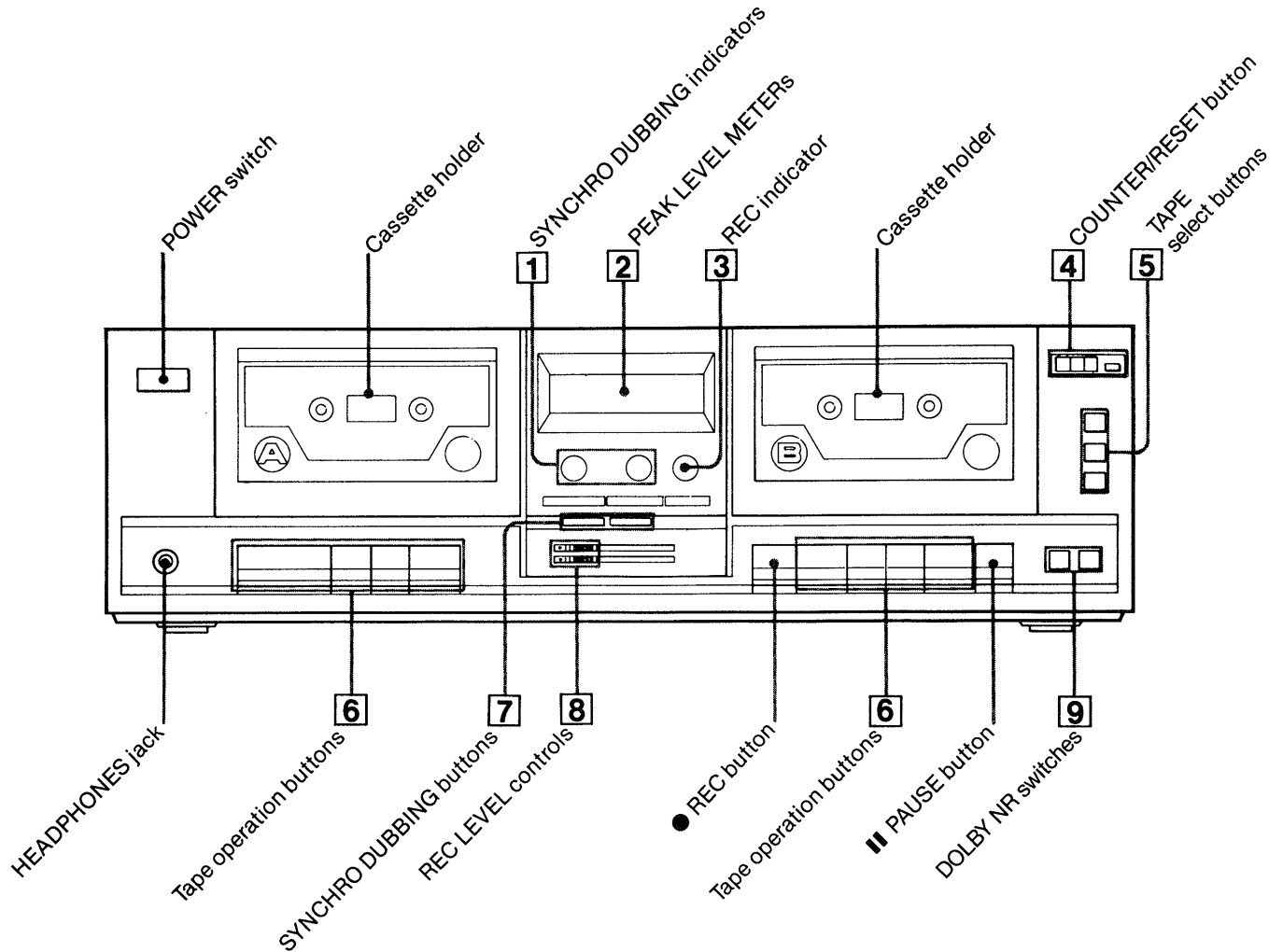

Fig. A. Using an AC voltmeter to check AC leakage.

LOCATION AND FUNCTION OF CONTROLS

Front panel



① SYNCHRO DUBBING indicators

The dubbing speed selected by the SYNCHRO DUBBING buttons lights up.

② PEAK LEVEL METERS

Show the peak input level of each channel during recording, and recorded levels in the playback mode. When both deck A and B are activated, the meters show the level of deck B.

③ REC (record) indicator

Lights up when the ● button is pressed (except when using the SYNCHRO DUBBING button).

④ COUNTER (tape counter) and RESET button (deck B)

Use the tape counter as a reference when searching for recorded materials. To reset to zero, press the RESET button.

⑤ TAPE select buttons (deck B)

Press to select the tape type.
TYPE I : for TYPE I (normal) tapes
TYPE II : for TYPE II (CrO₂) tapes
TYPE IV : for TYPE IV (metal) tapes

⑥ Tape operation buttons

▶ **PLAY button**

◀◀ **REW (rewind) button**
 Press to rewind the tape.

▶▶ **FF (fast-forward) button**
 Press to advance the tape rapidly.

■▲ **STOP/EJECT button**

7 SYNCHRO DUBBING buttons

Press to dub from deck A to deck B.

HIGH SPEED: Press for high speed dubbing.

NORMAL SPEED: Press for normal speed dubbing.

8 REC LEVEL (recording level) controls

Adjust the recording level while referring to the PEAK LEVEL METERS.

9 DOLBY NR switches (deck B)

Press to record or play back using the Dolby* NR (Noise Reduction) system.

Dolby NR system	Switch setting	
	Left switch	Right switch
Dolby B	☐ ON	☐ B-TYPE
Dolby C	☐ ON	☐ C-TYPE
Dolby OFF	☐ OFF	Either position

* "Dolby" and the double-D symbol are trade marks of the Dolby Laboratories Licensing Corporation. Noise reduction system manufactured under license from Dolby Laboratories Licensing Corporation.

Rear panel

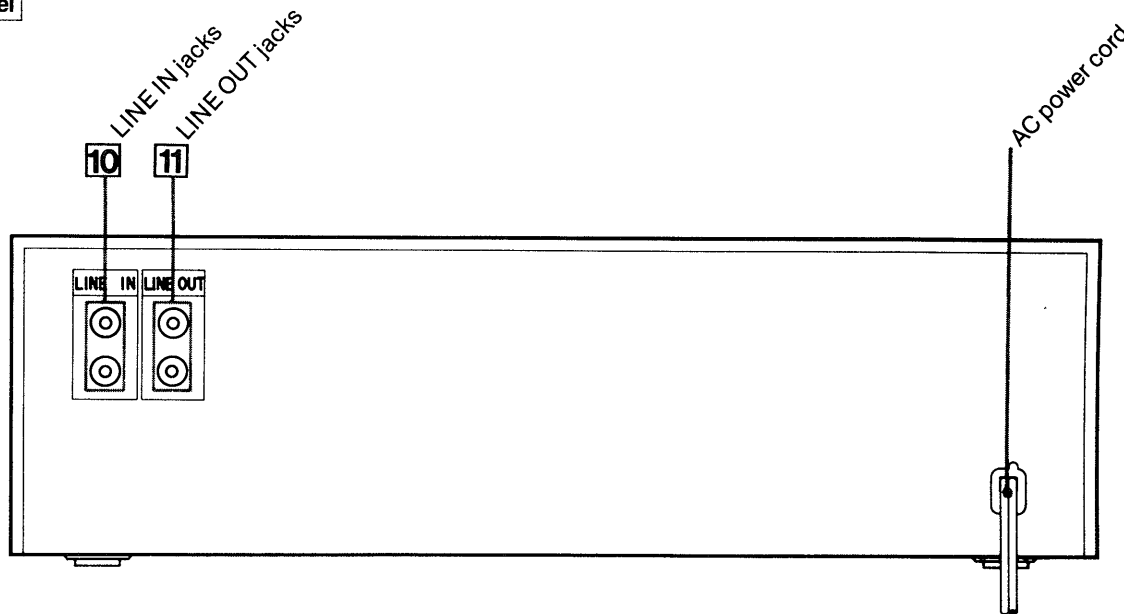

10 LINE IN (line input) jacks (phono jack)

Accept tape outputs from an amplifier for tape recording.

11 LINE OUT (line output) jacks (phono jack)

Accept tape inputs from an amplifier for playing back a tape.

SECTION 1
OUTLINE

1-1. BLOCK DIAGRAM

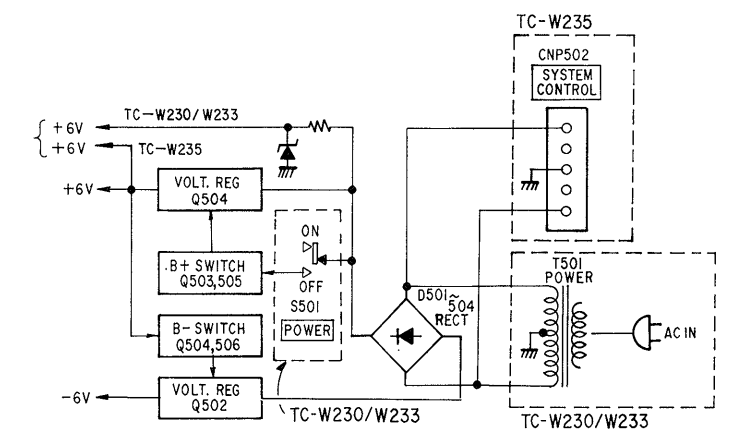
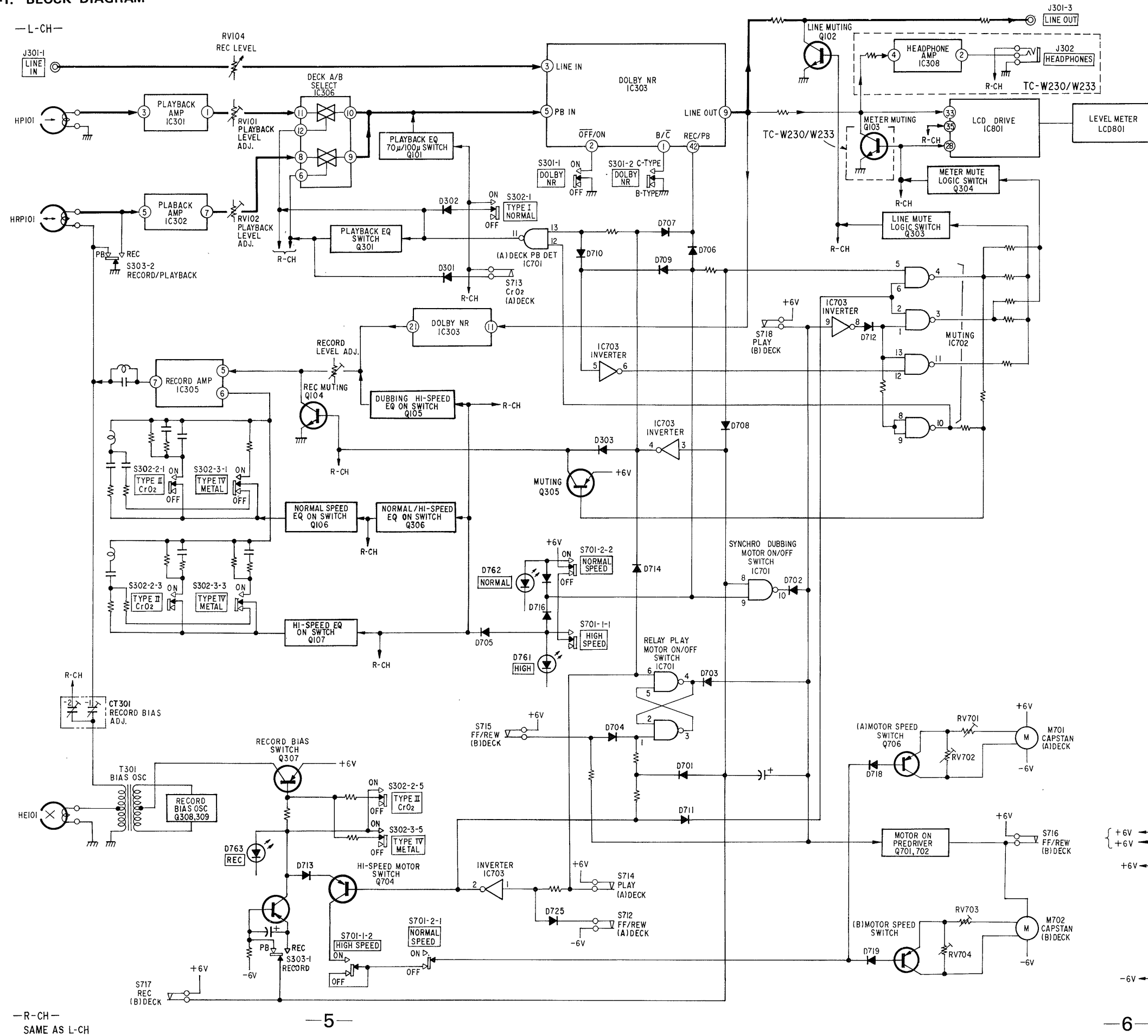

-R-CH-
SAME AS L-CH

SECTION 2
DISASSEMBLY

Note: Follow the disassembly procedure in the numerical order given.

CASE REMOVAL
Remove case by taking out four screws securing case.

FRONT PANEL REMOVAL

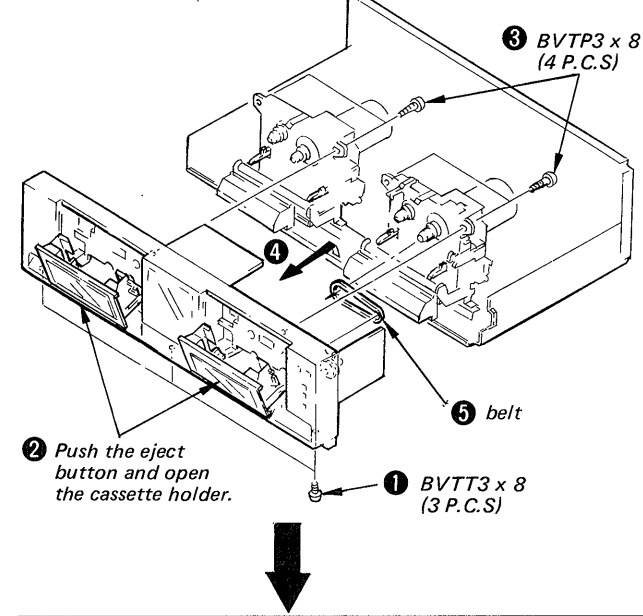

CASSETTE HOLDER REMOVAL

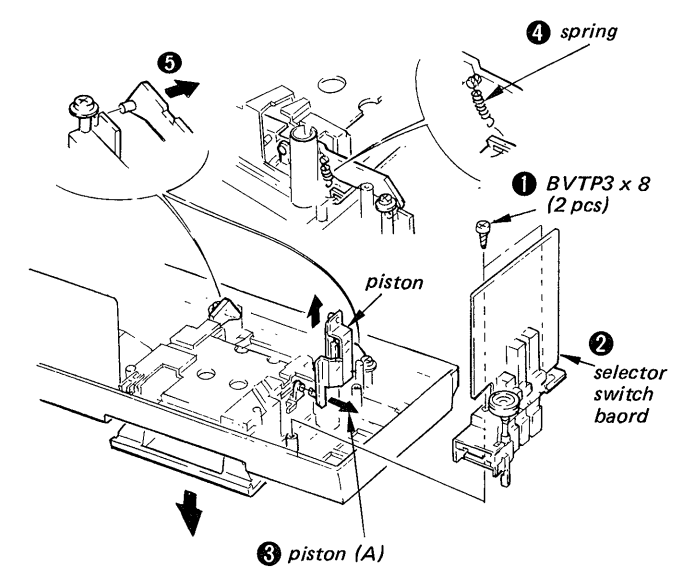

MECHANISM BLOCK REMOVAL

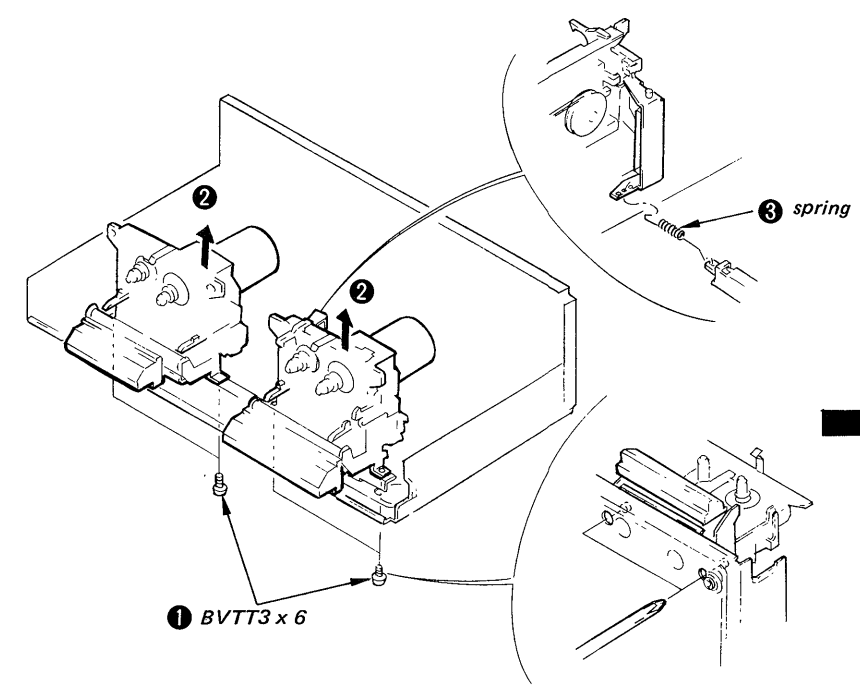

WHEN REINSTALLING;

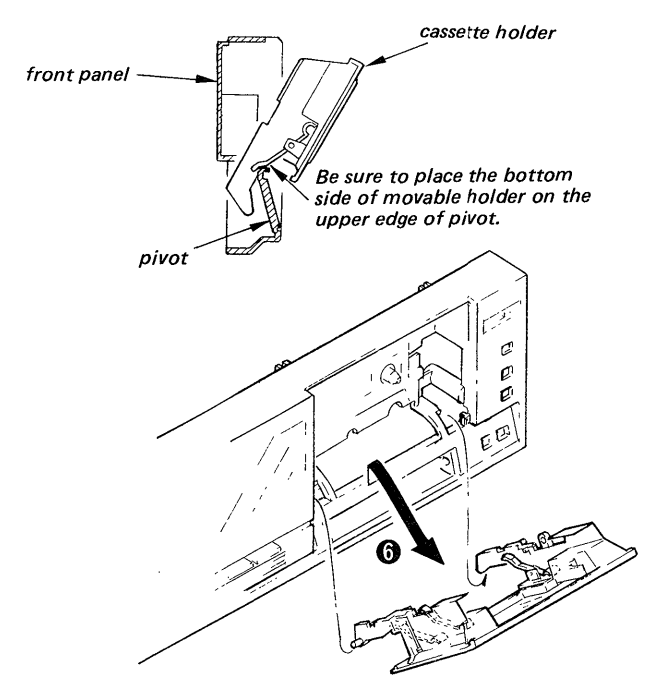

MOTOR, FR BELT, DRIVE BELT, AUTO BELT

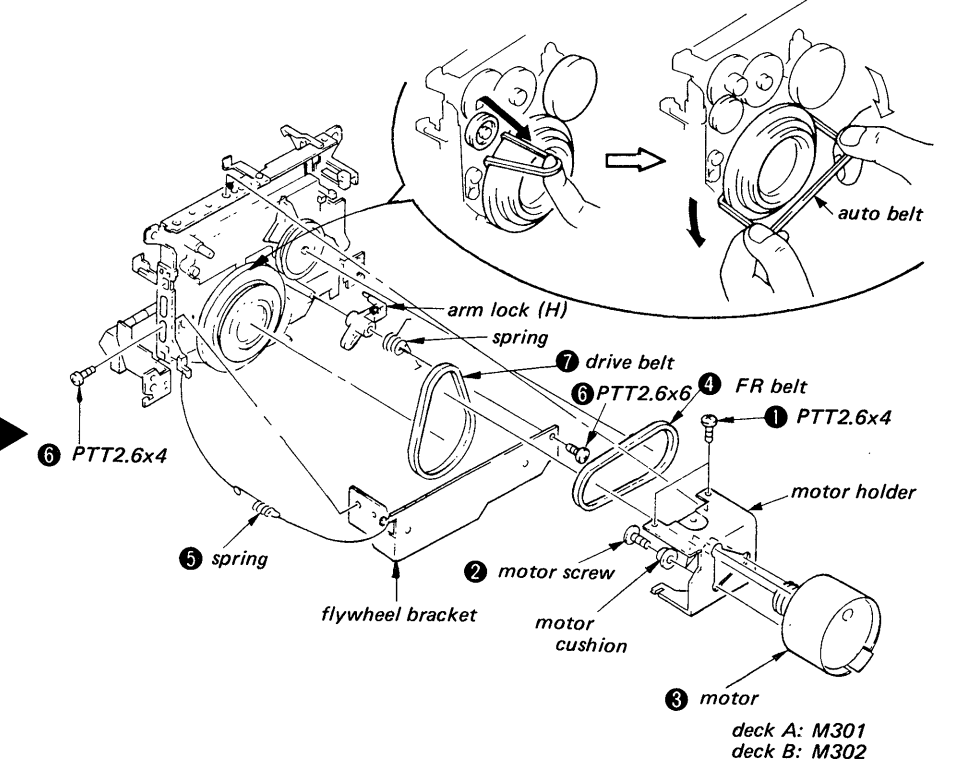

HEAD, PINCH ROLLER

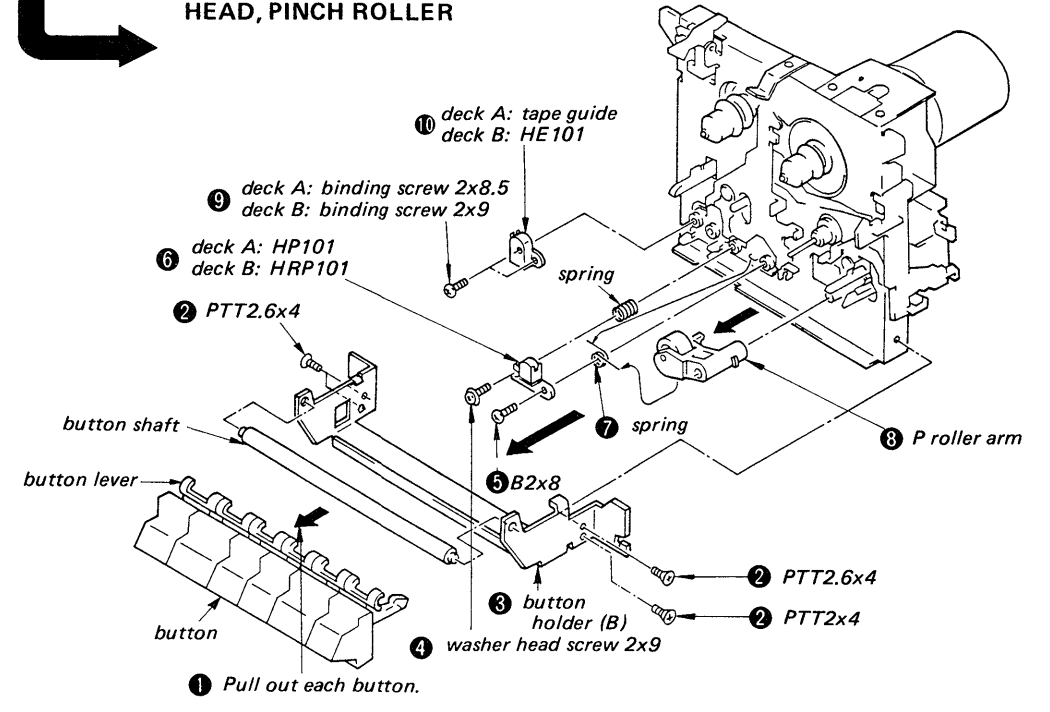

SECTION 3
ADJUSTMENTS

3-1. MECHANICAL ADJUSTMENTS

PRECAUTION

- Clean the following parts with a denatured-alcohol-moistened swab:

record/playback head	pinch roller
erase head	rubber belts
capstan	idlers
- Demagnetize the record/playback head with a head demagnetizer.
- Do not use a magnetized screwdriver for the adjustments.
- After the adjustments, apply suitable locking compound to the parts adjusted.
- The adjustments should be performed with the rated power supply voltage unless otherwise noted.

Torque Measurement

Torque	Torque meter	Meter reading
FWD	CQ-102C	35 – 70 g·cm (0.49 – 1.04 oz·inch)
FWD Back tension	CQ-102C	2 – 6 g·cm (0.014 – 0.08 oz·inch)
FF, REW	CQ-201B	70 – 160 g·cm (0.98 – 2.22 oz·inch)

Head Height Adjustment

- Prepare an adjustment cassette as shown below.

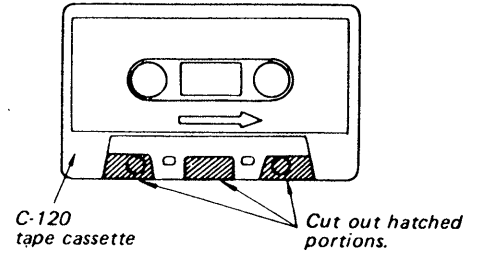

- In playback mode and viewing from the front, adjust the head heights to eliminate tape curl and tape twist at the portions shown by the arrows.

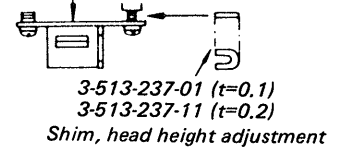
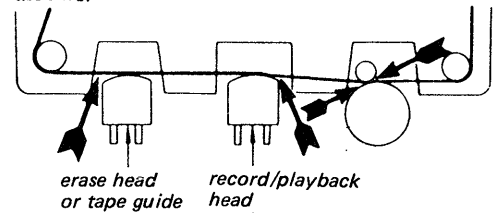

Pinch Roller Pressure Measurement

— Playback Mode —

- Slowly return the pinch roller and read the spring scale just when the pinch roller starts rotating. (The capstan should first contact here.)

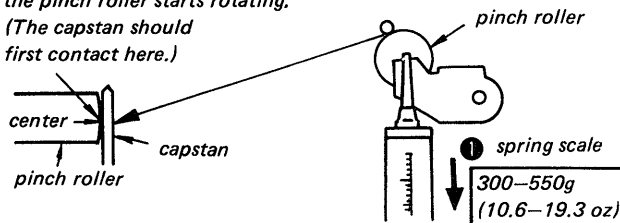

3-2. ELECTRICAL ADJUSTMENTS

1. Demagnetize the record/playback head with a head demagnetizer. (Do not bring the head demagnetizer close to the erase head.)
 2. Do not use a magnetized screwdriver for the adjustments.
 3. After the adjustments, apply suitable locking compound to the parts adjusted.
 4. The adjustments should be performed with the rated power supply voltage unless otherwise noted.
 5. The adjustments should be performed in the order given in this service manual. (As a general rule, playback circuit adjustment should be completed before performing recording circuit adjustment.)
 6. The adjustments should be performed for both L-CH and R-CH.
- Switches and controls should be set as follows unless otherwise specified.
 DOLBY NR switch: OFF
 SYNCHRO DUBBING switch: OFF
 TAPE TYPE switch: TYPE I
 - Standard Record:
 Deliver the standard input signal level to the input jack and set the REC LEVEL control to obtain the standard output signal level.

Mode: record

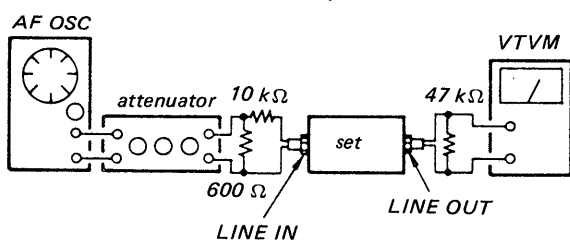

Standard Input Level

	LINE IN
Source impedance	10 kΩ
input level	0.25 V (-10 dB)

Standard Output Level

	LINE OUT
load impedance	47 kΩ
output level	0.44 V (-5 dB)

Record/playback Head Azimuth Adjustment

Procedure:

DECK A , **DECK B**

1. Mode: playback

test tape
P-4-A100
(10 kHz, -10 dB)

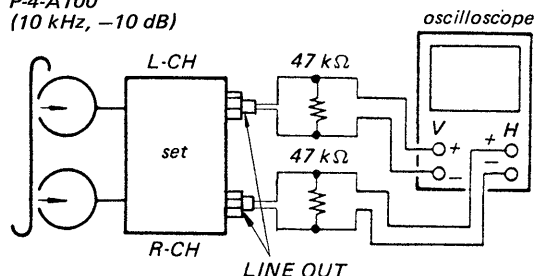

Adjust the adjustment screw so that amplitude of output pattern becomes in maximum both in vertically and horizontally within the good range shown below. Output-level difference between channels should be within 1 dB.

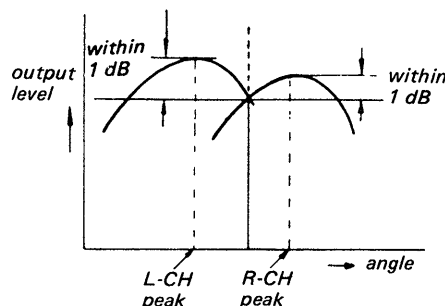

Phase Check

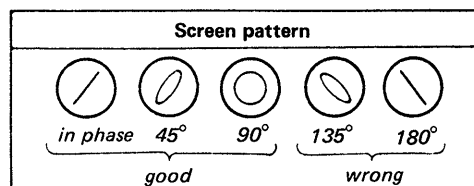

3. After the adjustment finishing with tightening direction, lock the adjustment screw with locking compound.
4. After the locking compound dried out, reassemble the function switch block.

Adjustment Location:

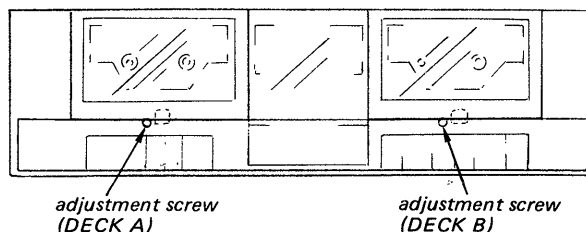

Tape Speed Adjustment DECK A , DECK B

Procedure:

Mode: playback

Note: Perform NORMAL SPEED first.

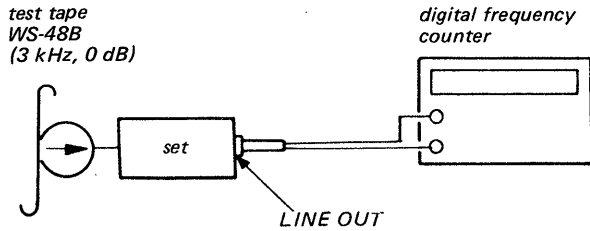

Specifications:

SYNCHRO DUBBING switch	Adjustment Part		Digital frequency counter
NORMAL SPEED	Deck A	RV701	2980 – 3020 Hz
	Deck B	RV703	
HIGH SPEED	Deck A	RV702	5960 – 6040 Hz
	Deck B	RV704	

Adjustment Location: – audio board –

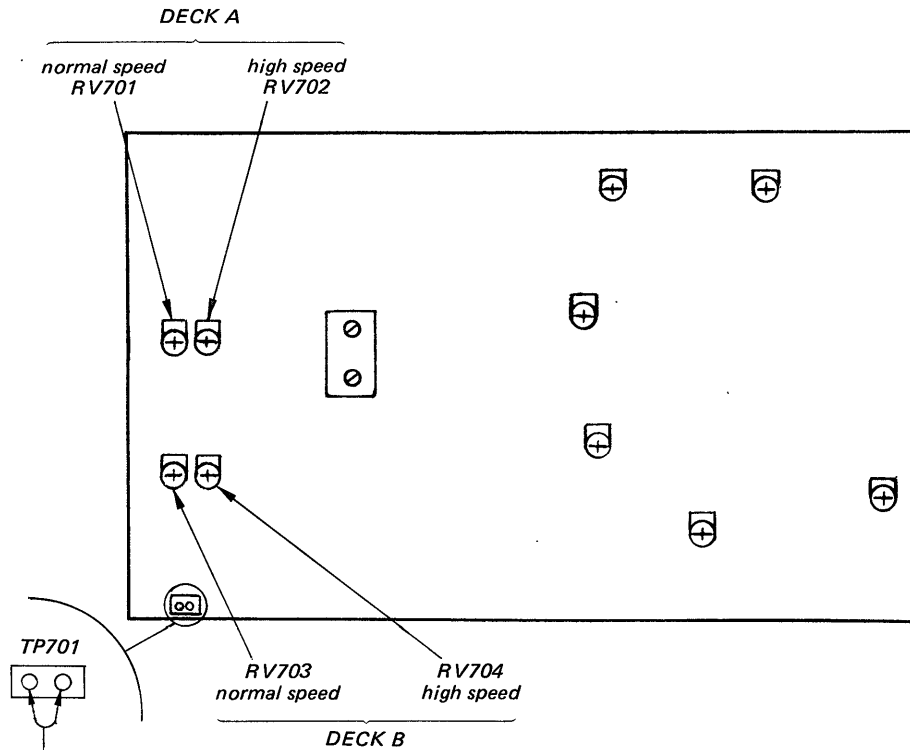

Short. Do not put the set to record mode in the shorted condition.

Playback Level Adjustment

DECK A , DECK B

Procedure:

Mode: playback

test tape
P-4-L300
(315 Hz, 0 dB)

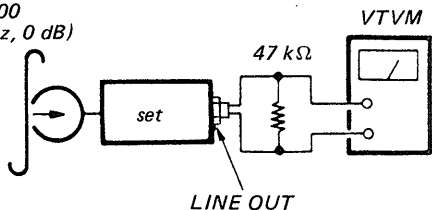

Adjust the DECK A: RV101, DECK B: RV102 (L-CH) and DECK A: RV201, DECK B: RV202 (R-CH) so that VTVM reads 0.44 V (−5 dB).

Specification:

LINE OUT level: 0.41 to 0.46 V
(−5.5 to −4.5 dB)

Level difference between channels:
less than 0.5 dB

Check that the LINE OUT level does not change in playback mode while changing the mode from playback to stop several times.

Adjustment Location:

— audio board —

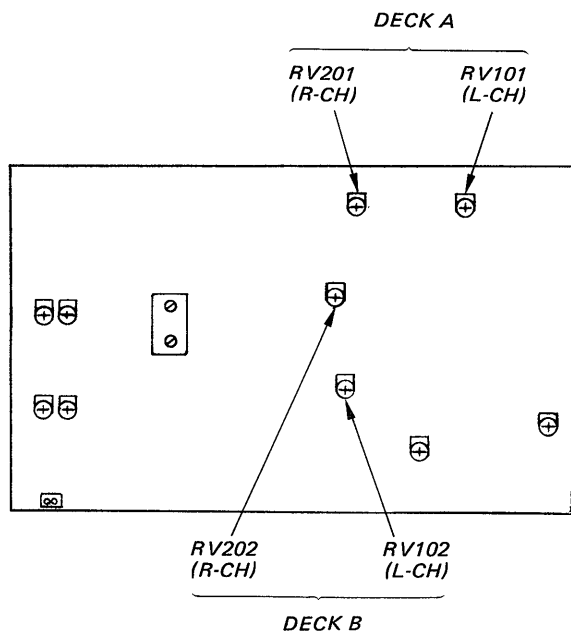

Record Bias Adjustment

DECK B

Setting:

REC LEVEL control: standard record
(See page 10.)

Procedure:

1. Mode: record

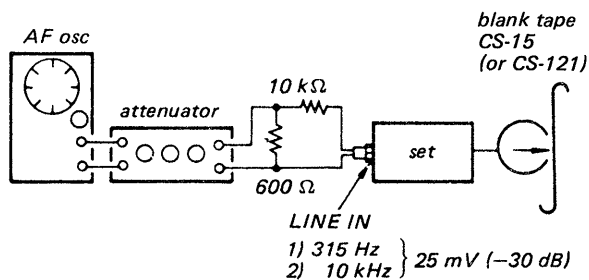

2. Mode: Playback

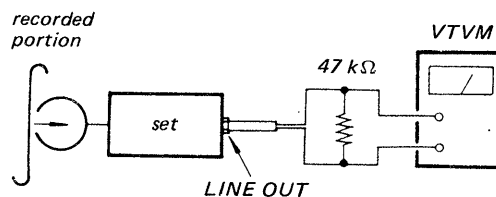

Confirm that the 10 kHz playback output is 0 dB relative to the 315 Hz output. If necessary, adjust CT301-1 (L-CH), CT301-2 (R-CH) and repeat the steps given above.

Adjustment Location:

— audio board —

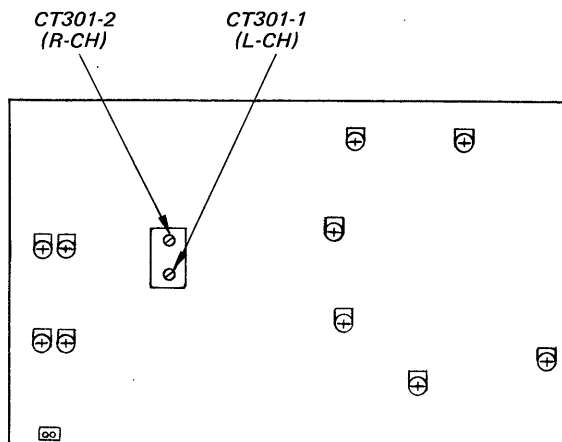

Record Level Adjustment

DECK B

Setting:

REC LEVEL control: standard record
(See page 10.)

Procedure:

1. Mode: record

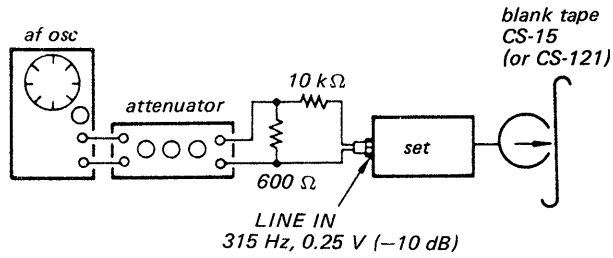

2. Mode: playback

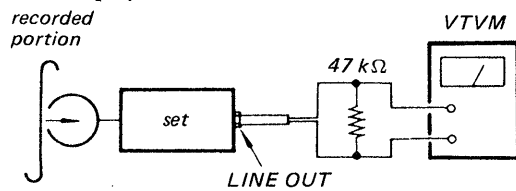

3. Play back the signal recorded in step 1.
Confirm that the signal level is within the specification below. If necessary, adjust RV103 (L-CH), RV203 (R-CH) and repeat the step 1-3.

Specification:

LINE OUT level: 0.41–0.46 V
–5dB ± 0.5dB

Adjustment Location:

– audio board –

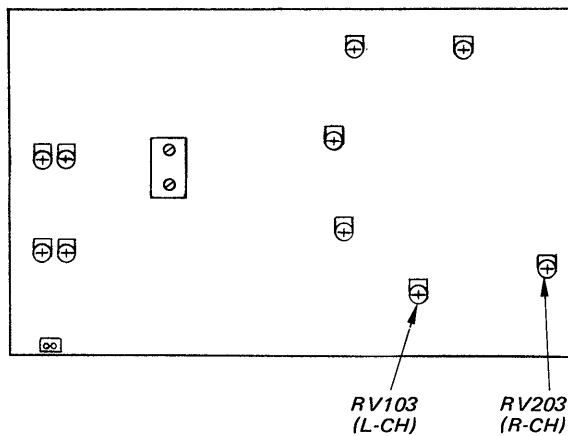

SECTION 4 EXPLODED VIEWS AND PARTS LIST

NOTE:

- The mechanical parts with no reference number in the exploded views are not supplied.
- Items marked " * " are not stocked since they are seldom required for routine service. Some delay should be anticipated when ordering these items.
- The construction parts of an assembled part are indicated with a collation number on the remark column.

The components identified by shading and mark  are critical for safety. Replace only with part number specified.

Les composants identifiés par une trame et une marque  sont critiques pour la sécurité. Ne les remplacer que par une pièce portant le numéro spécifié.

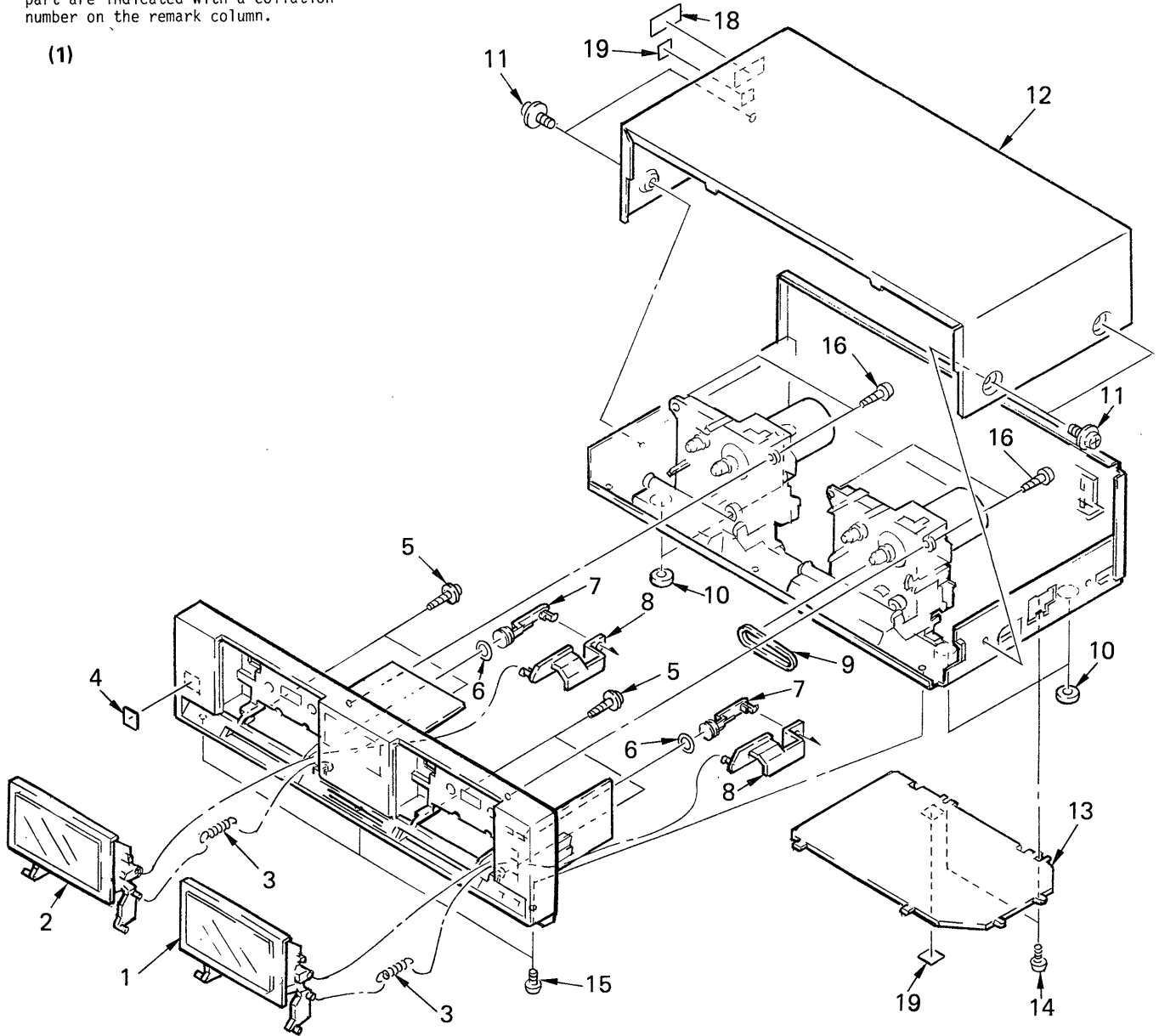

No.	Part No.	Description	Remarks	No.	Part No.	Description	Remarks
1	X-3332-419-1 (W233).....	HOLDER (B) ASSY, CASSETTE		10	3-576-731-00	FELT (H)	
	X-3332-421-1 (W230/W235)...	HOLDER (B) ASSY, CASSETTE		11	4-886-821-01	SCREW, M3 CASE	
2	X-3332-418-1 (W233).....	HOLDER (A) ASSY, CASSETTE		12	3-332-437-01	CASE	
	X-3332-420-1 (W230/W235)...	HOLDER (A) ASSY, CASSETTE		13	*3-332-430-01	PLATE, BOTTOM	
3	3-489-099-11	SPRING, TENSION		14	7-685-871-01	SCREW +BVTT 3X6 (S)	
4	3-703-710-41 (W235).....	STICKER, SONY SYMBOL (12)		15	7-685-752-04	SCREW +BVTT 3X8 (S)	
	3-703-713-41 (W230/W233)...	STICKER, SONY SYMBOL (10)		16	7-685-646-71	SCREW +BVTP 3X8 TYPE2 N-S	
5	3-703-135-00	SCREW, TAPPING		17	3-332-442-01 (W230:AE1)...	LABEL, APPROVAL BLIND	
6	3-312-441-00	RING, PISTON		18	3-703-079-21 (W230:UK)...	LABEL, CAUTION (BACK)	
7	3-312-458-03	PISTON (A)		19	3-703-680-00 (US)...	LABEL, CAUTION, SUB, NEW UL	
8	*3-325-026-01	LEVER (B), EJECT		20	3-307-371-00	SPRING (LEFT)	
9	3-530-181-XX	BELT, DETECTING		21	3-332-415-21 (W230/W235)...	PLATE, TRANSPARENT	
					3-332-415-31 (W233).....	PLATE, TRANSPARENT	

(2)

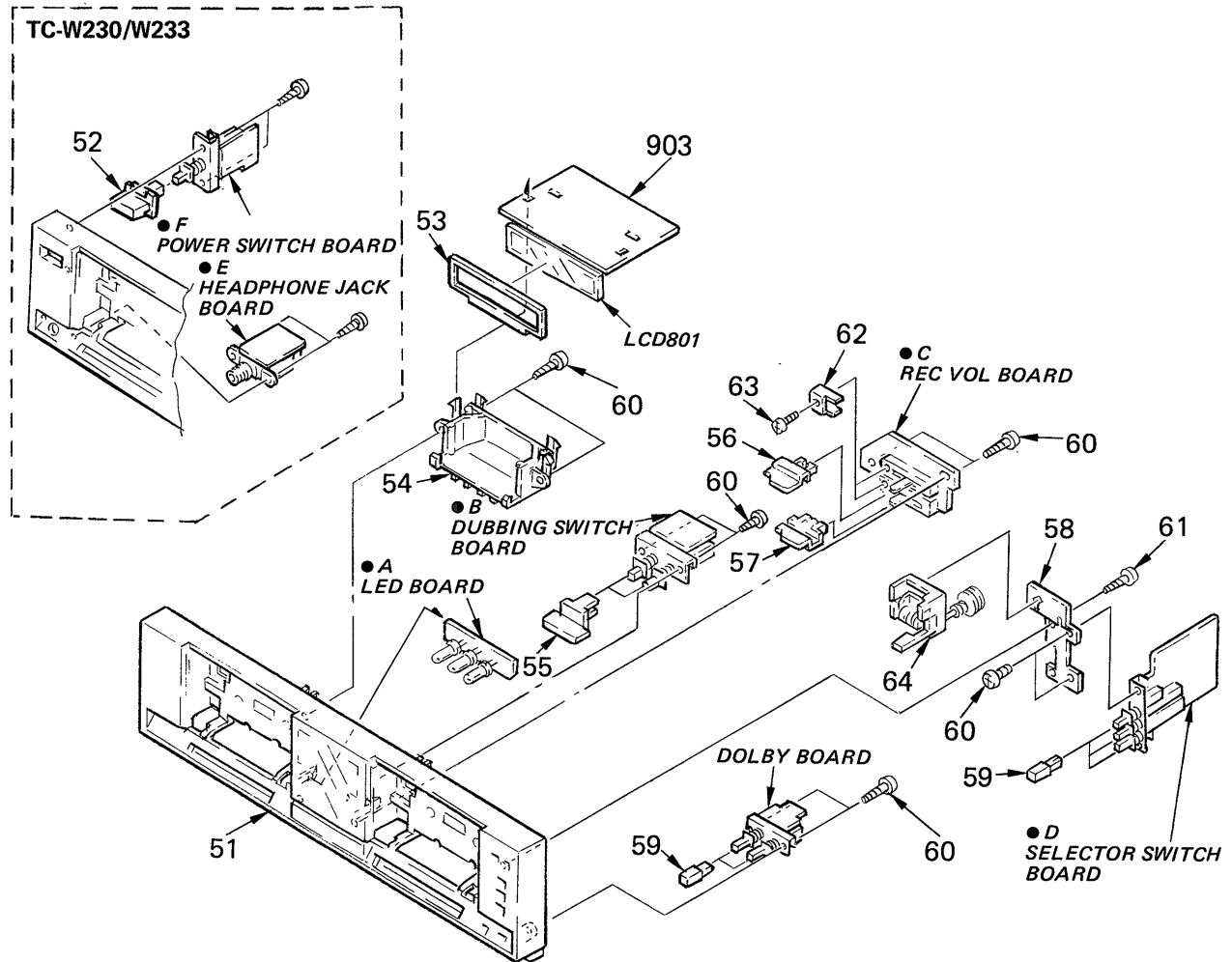

No.	Part No.	Description	Remarks	No.	Part No.	Description	Remarks
51	X-3332-414-1	(W230:US,Canadian)...PANEL ASSY, FRONT		58	*3-332-429-01	BRACKET, COUNTER	
	X-3332-415-1	(W230:AEP,UK,E).....PANEL ASSY, FRONT		59	4-855-804-11	KNOB, SQUARE	
	X-3332-416-1	(W233:US).....PANEL ASSY, FRONT		60	7-685-646-01	SCREW +BVTP 3X8 TYPE1	
	X-3332-417-1	(W235:E).....PANEL ASSY, FRONT		61	7-685-646-71	SCREW +BVTP 3X8 TYPE2 N-S	
52	3-332-417-01	(W230/W233)...KNOB (POWER), PUSH		62	*3-332-443-01	PLATE, GROUND, REC VOL	
53	*3-332-449-01	CUSHION, DISPLAY		63	7-627-553-18	SCREW, PRECISION +P 2X2	
54	*3-332-423-01	HOUSE, LAMP		64	1-548-589-51	COUNTER, TAPE (MIDDLE TYPE)	
55	3-332-420-01	BUTTON, DUBBING		903	*1-618-741-11	PC BOARD, LCD LEVEL METER	
56	3-323-446-01	KNOB (LEFT), CONTROL		LCD801	1-520-488-11	METER, LEVEL	
57	3-323-447-01	KNOB (RIGHT), CONTROL		S501	1-570-103-11	(W230/W233)..SWITCH, PUSH(1 KEY)(POWER)	

TC-W230/W233/W235

(3)

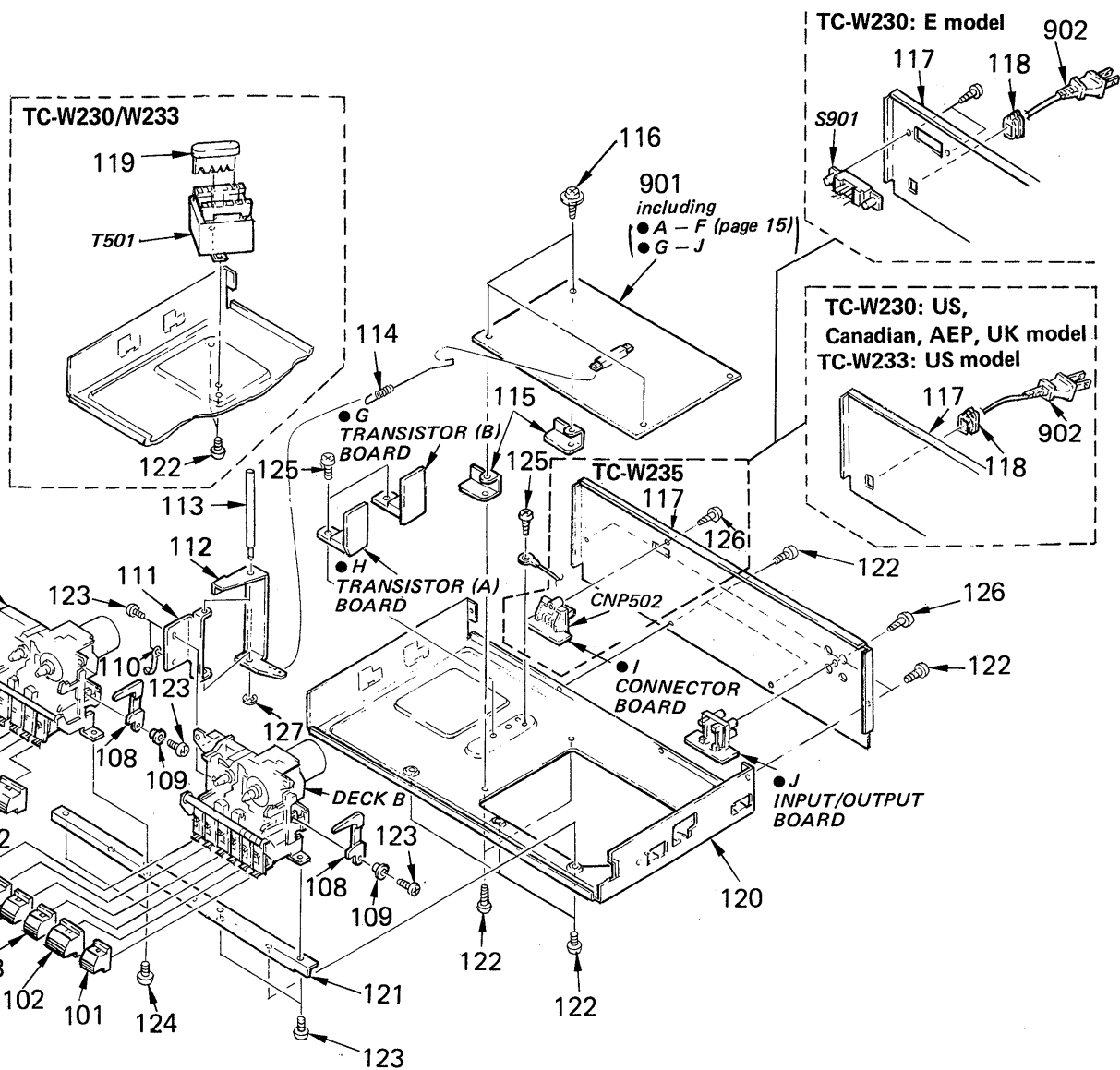

No.	Part No.	Description	Remarks	No.	Part No.	Description	Remarks
101	3-332-433-11	BUTTON (B), CONTROL		119	*3-332-444-01	(W230/W233)...COVER, TRANSFORMER SAFETY	
102	3-332-434-01	BUTTON (C), CONTROL		120	*3-332-438-01	CHASSIS	
103	3-332-432-01	BUTTON (A), CONTROL		121	*3-332-431-01	BRACKET, MD	
104	3-332-433-01	BUTTON (B), CONTROL		122	7-685-752-04	SCREW +BVTT 3X8 (S)	
105	3-332-434-11	BUTTON (C), CONTROL		123	7-685-791-04	SCREW +BVTT 2.6X5 (S)	
106	3-332-432-11	BUTTON (A), CONTROL		124	7-685-751-09	SCREW +BVTT 3X6 (S)	
107	3-332-435-01	BUTTON (D), CONTROL		125	7-685-871-01	SCREW +BVTT 3X6 (S)	
108	*3-325-023-01	LEVER, EJECT		126	7-685-646-01	SCREW +BVTP 3X8 TYPE1	
109	3-325-028-01	COLLAR, EJECT		127	7-624-105-04	STOP RING 2.3, TYPE -E	
110	*3-701-822-00	HOLDER, WIRE		901	*A-2056-320-A	(W230/W233:US)...MOUNTED PCB, AUDIO	
111	*3-327-629-01	BASE, REC			*A-2056-321-A	(W230:Canadian,AEP,E)..MOUNTED PCB, AUDIO	
112	*3-327-630-01	ARM, REC			*A-2056-322-A	(W230:UK)...MOUNTED PCB, AUDIO	
113	*3-327-631-01	SHAFT, REC			*A-2056-330-A	(W235:E)....MOUNTED PCB, AUDIO	
114	3-332-445-01	SPRING		902	▲.1-534-817-XX	(W230:AEP)...CORD, POWER	
115	*3-332-428-01	BRACKET (1), PC BOARD			▲.1-551-188-XX	(W230:E)....CORD, POWER	
116	3-703-249-01	SCREW, S TIGHT, +PTTWH 3X6			▲.1-551-628-00	(W230:US,Canadian/W233:US)...CORD, POWER	
117	*3-332-436-01	(W230:US,Canadian)...PLATE, JACK			▲.1-556-562-00	(W230:UK)....CORD, POWER	
	*3-332-436-11	(W230:E).....PLATE, JACK		CNP502	1-564-067-00	(W235)...SOCKET, CONNECTOR 5P	
	*3-332-436-21	(W230:AEP)...PLATE, JACK		S901	▲.1-570-307-11	(W230:E)...SWITCH, VOLTAGE CHANGE	
	*3-332-436-31	(W230:UK)....PLATE, JACK		T501	▲.1-448-497-11	(W230:E).....TRANSFORMER, POWER	
	*3-332-436-41	(W235:E).....PLATE, JACK			T501	▲.1-448-498-11	(W230:US,Canadian/W233:US) ...TRANSFORMER, POWER
	*3-332-436-51	(W233:US)....PLATE, JACK			T501	▲.1-448-499-11	(W230:AEP,UK)...TRANSFORMER, POWER
118	3-703-244-00	(W230:AEP,UK)...BUSHING (2104), CORD					
	3-703-571-00	(W230:US,Canadian,E/W233:US)...BUSHING (S)(4516), CORD					

SEE ADDITIONAL INFORMATION

TC-W230/W233/W235 TC-W230/W233/W235

SEE ADDITIONAL INFORMATION

(4) DECK A : TCM-54FMF

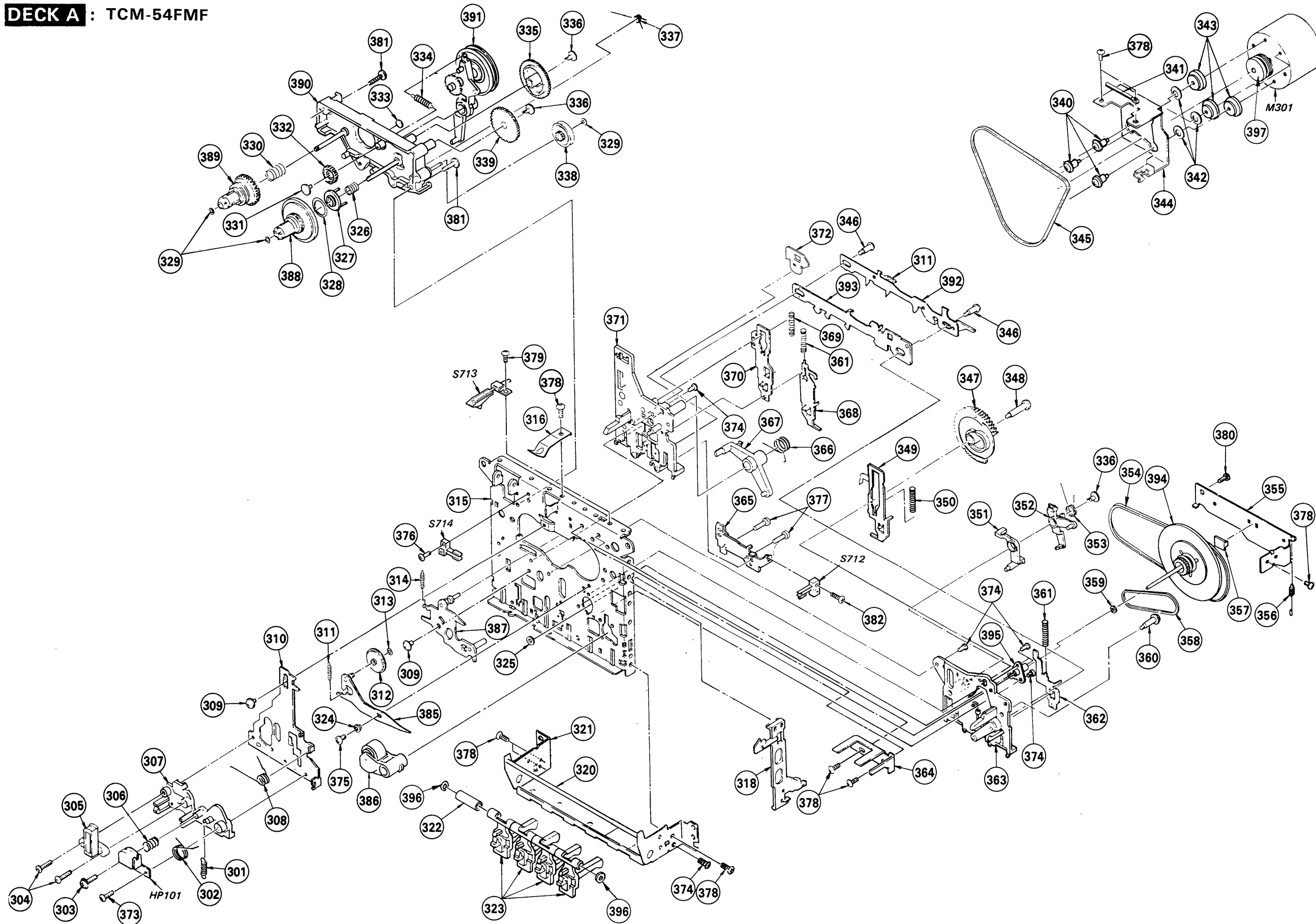

SEE ADDITIONAL INFORMATION

REVISED

TCM-54FMF (DECK A)

No.	Part No.	Description
301	3-595-956-01	SPRING
302	3-595-955-01	SPRING
303	3-595-972-01	SCREW (2X9), WASHER HEAD
304	3-596-938-01	SCREW (2X8.5), BINDING
305	1-543-986-01	GUIDE, TAPE
306	3-595-954-01	SPRING
307	*3-595-926-01	BASE, HEAD
308	3-595-953-01	SPRING
309	3-595-964-01	SCREW (A)
310	*3-595-912-01	CHASSIS, HEAD
311	3-595-951-01	SPRING
312	3-595-941-01	IDLER, PLAY
313	3-595-969-01	WASHER, POLYSLIDER
314	3-595-946-01	SPRING (C)
315	*3-595-901-01	CHASSIS
316	3-595-916-01	SPRING
318	3-595-932-01	LEVER (F), EJECT
320	*3-595-920-01	SHAFT (SO), BUTTON
321	*3-595-020-01	HOLDER (B), BUTTON
322	*3-596-018-01	COLLAR, BITTON
323	3-595-933-01	LEVER, BUTTON
324	3-595-919-01	COLLAR
325	3-595-970-01	WASHER, OIL STOP
326	3-595-961-01	SPRING
327	3-595-938-01	CLUTCH, AUTO
328	3-595-968-01	FELT, AUTO CLUTCH
329	3-558-708-11	WASHER, STOPPER
330	3-595-957-01	SPRING
331	3-595-928-01	BUSHING
332	3-595-927-01	GEAR, FF
333	3-596-013-01	WASHER (5.6X0.19), LUMILER
334	3-595-963-01	SPRING
335	3-595-937-01	GEAR, AUTO CAM
336	3-595-934-01	BUSHING
337	3-595-960-01	SPRING
338	3-595-935-01	PULLEY, AUTO
339	3-595-936-01	GEAR, AUTO
340	3-515-973-01	SCREW, MOTOR
341	*3-596-004-01	CLAMP, CORD
342	3-598-364-01	WASHER (B)
343	3-595-945-01	CUSHION, MOTOR
344	*3-596-024-01	HOLDER, MOTOR
345	3-596-010-01	BELT, FR
346	3-595-965-01	SCREW (B)
347	3-595-929-01	GEAR (C)
348	3-595-967-01	SCREW (D)
349	*3-595-904-01	LEVER (H), FF
350	3-595-947-01	SPRING
351	3-595-939-01	ARM (B), AUTO
352	3-595-940-01	ARM, AUTO LOCK
353	3-595-962-01	SPRING
354	3-595-998-01	BELT, DRIVE
355	*3-595-995-01	BRACKET, FLYWHEEL
356	3-595-959-01	SPRING
357	3-595-931-01	SPACER, CAPSTAN

TCM-54FMF (DECK A)

No.	Part No.	Description
358	3-595-944-01	BELT, AUTO
359	3-701-437-21	WASHER, POLY-SLIDER
360	3-595-966-01	SCREW (C)
361	3-595-948-01	SPRING
362	*3-595-991-01	LEVER, STOP
363	3-595-922-01	HOLDER (A), LEVER
364	*3-595-913-01	PROTECTOR, SWITCH
365	*3-595-906-01	BRACKET, SOLENOID
366	3-595-983-01	SPRING
367	3-595-930-01	ARM (H), LOCK
368	*3-595-905-01	LEVER (H), REW
369	3-595-949-01	SPRING
370	*3-595-909-01	LEVER (B), PLAY
371	3-595-923-01	HOLDER (B), LEVER
372	*3-595-918-01	ARM, INTERLOCK
373	7-621-772-40	SCREW +B 2X8
374	7-685-781-01	SCREW +PTT 2X4 (S)
375	7-685-782-01	SCREW +PTT 2X5 (S)
376	7-685-783-01	SCREW +PTT 2X6 (S)
377	7-685-786-01	SCREW +PTT 2X12 (S)
378	7-685-790-01	SCREW +PTT 2.6X4 (S)
379	7-685-791-01	SCREW +PTT 2.6X5 (S)
380	7-685-792-01	SCREW +PTT 2.6X6 (S)
381	3-685-863-01	SCREW +BVTT 2.6X8 (S)
382	7-685-864-01	SCREW +BVTT 2.6X10 (S)
385	*X-3595-902-1	ARM (HT) ASSY, IDLER
386	X-3595-905-1	ARM ASSY, P ROLLER
387	*X-3595-917-1	ARM ASSY, SHIFT
388	X-3595-906-1	REEL ASSY, TAKE-UP
389	X-3595-907-1	REEL ASSY, SUPPLY
390	X-3595-908-1	BASE ASST (B), REEL
391	X-3595-919-1	ARM ASSY, CLUTCH
392	*X-3595-904-1	CAM (B) ASSY, LOCK
393	X-3595-918-1	CAM (A) ASSY, LOCK
394	X-3595-920-1	FLYWHEEL ASSY (S)
395	X-3595-911-1	HOUSING ASSY
396	3-701-440-01	WASHER
397	X-3595-923-1	MOTOR ASSY (W/PULLEY)

ELECTRICAL PARTS

HP101	1-543-363-11	HEAD (PB)
M301	X-3595-921-1	MOTOR, CAPSTAN
S712	1-570-302-11	SWITCH, LEAF (B)(FF/REW)
S713	1-570-305-11	SWITCH, LEAF (E)(CrO2)
S714	1-570-304-11	SWITCH, LEAF (D)(PLAY)

SEE ADDITIONAL INFORMATION

REVISED

TCM-53FMF (DECK B)

No.	Part No.	Description
401	3-595-956-01	SPRING
402	3-595-955-01	SPRING
403	3-595-972-01	SCREW (2X9), WASHER HEAD
404	3-595-971-01	SCREW (2X9), BINDING
405	3-595-954-01	SPRING
406	*3-595-926-01	BASE, HEAD
407	3-595-953-01	SPRING
408	3-595-964-01	SCREW (A)
409	*3-595-912-01	CHASSIS, HEAD
410	3-595-951-01	SPRING
411	3-595-941-01	IDLER, PLAY
412	3-595-946-01	SPRING (C)
413	3-595-969-01	WASHER, POLYSLIDER
414	3-595-919-01	COLLAR
415	*3-595-902-01	ARM, PAUSE
416	3-558-708-11	WASHER, OIL STOP
417	*3-595-901-01	CHASSIS
419	3-595-932-01	LEVER (F), EJECT
420	*3-595-020-01	HOLDER (B), BUTTON
421	*3-595-920-01	SHAFT, BUTTON
422	3-595-933-01	LEVER, BUTTON
423	*3-596-023-01	BRACKET, REC SWITCH
424	*3-595-994-01	ARM, REC
425	*3-596-006-01	SCREW (2.6X22), DIA
426	*3-681-432-01	CLAMP, CORD
427	3-595-925-01	SENSOR, REC
428	3-595-916-01	SPRING
429	3-595-961-01	SPRING
430	3-595-938-01	CLUTCH, AUTO
431	3-595-968-01	FELT, AUTO CLUTCH
432	3-558-708-01	WASHER, STOPPER
433	3-595-928-01	BUSHING
434	3-595-957-01	SPRING
435	3-595-927-01	GEAR, FF
436	3-596-013-01	WASHER (5.6X0.19), LUMILER
437	3-595-963-01	SPRING
438	3-595-937-01	GEAR, AUTO CAM
439	3-595-928-01	BUSHING
440	3-595-960-01	SPRING
441	3-595-935-01	PULLEY, AUTO
442	3-595-936-01	GEAR, AUTO
443	3-595-011-01	WASHER (B)
444	3-595-945-01	CUSHION, MOTOR
445	*3-595-995-01	HOLDER, MOTOR
446	3-515-973-01	SCREW, MOTOR
447	3-596-010-01	BELT, FR
448	3-595-965-01	SCREW (B)
449	*3-595-918-01	ARM, INTERLOCK
450	*3-595-992-01	LEVER (C), REC
451	3-595-923-01	HOLDER (B), LEVER
452	*3-595-909-01	LEVER (B), PLAY
453	3-595-949-01	SPRING
454	3-595-948-01	SPRING
455	*3-595-905-01	LEVER (H), REW
456	3-595-983-01	SPRING
457	*3-595-907-01	LEVER (BH), REC

TCM-53FMF (DECK B)

No.	Part No.	Description
458	3-595-950-01	SPRING (B)
459	*3-595-906-01	BRACKET, SOLENOID
460	3-595-930-01	ARM (H), LOCK
461	*3-595-904-01	LEVER (H), FF
462	3-595-929-01	GEAR (C)
463	3-595-967-01	SCREW (D)
464	3-595-962-01	SPRING
465	3-595-940-01	ARM, AUTO LOCK
466	3-595-939-01	ARM (B), AUTO
467	3-595-947-01	SPRING
468	3-595-942-01	BELT, DRIVE
469	*3-595-993-01	BRACKET, FLYWHEEL
470	3-595-932-01	SPACER, CAPSTAN
471	3-595-944-01	BELT, AUTO
472	3-595-966-01	SCREW (C)
473	3-595-952-01	SPRING
474	3-701-437-21	WASHER, POLY-SLIDER
475	3-595-924-01	CAM, PAUSE
476	*3-595-991-01	LEVER, STOP
477	3-595-922-01	HOLDER (A), LEVER
478	7-621-772-40	SCREW +B 2X8
479	7-624-104-04	STOP RING 2.0, TYPE -E
480	7-685-781-01	SCREW +PTT 2X4 (S)
481	7-685-782-01	SCREW +PTT 2X5 (S)
482	7-685-783-01	SCREW +PTT 2X6 (S)
483	7-685-786-01	SCREW +PTT 2X12 (S)
484	7-685-790-01	SCREW +PTT 2.6X4 (S)
485	7-685-791-01	SCREW +PTT 2.6X5 (S)
486	7-685-792-01	SCREW +PTT 2.6X6 (S)
487	7-685-863-01	SCREW +BVTT 2.6X8 (S)
488	7-685-864-01	SCREW +BVTT 2.6X10 (S)
489	3-595-959-01	SPRING
490	7-688-002-11	W 2.6, MIDDLE
492	X-3595-905-1	ARM ASSY, P ROLLER
493	*X-3595-902-1	ARM (HT) ASSY, IDLER
494	*X-3595-917-1	ARM ASSY, SHIFT
495	X-3595-906-1	REEL ASSY, TAKE-UP
496	X-3595-907-1	REEL ASSY, SUPPLY
497	X-3595-908-1	BASE ASST (B), REEL
498	X-3595-919-1	ARM ASSY, CLUTCH
499	*X-3595-904-1	CAM (B) ASSY, LOCK
500	3-595-910-01	CAM (A) ASSY, LOCK
501	X-3595-920-1	FLYWHEEL ASSY (S)
502	X-3595-911-1	HOUSING ASSY
503	*X-3595-903-1	LEVER (B) ASSY, PAUSE
504	7-685-854-01	SCREW, +BVTT 2 X8
505	X-3595-923-1	MOTOR ASSY (W/PULLEY)
506	3-701-441-01	WASHER

ELECTRICAL PARTS

HE101	1-543-261-11	HEAD, ERASE (886-01-24)
HRP101	1-543-260-11	HEAD, REC/PB (223-30-46)
M301	X-3595-923-1	MOTOR ASSY (W/PULLEY)
M302	X-3595-923-1	MOTOR ASSY (W/PULLEY)
S715	1-570-303-11	SWITCH, LEAF (C)(MOTOR)
S716	1-570-302-11	SWITCH, LEAF (B)(FF/REW)
S717	1-570-301-11	SWITCH, LEAF (A)(REC)
S718	1-570-304-11	SWITCH, LEAF (D)(PLAY)

SEE ADDITIONAL
SEE INFORMATION

TC-W230/W233/W235 TC-W230/W233/W235

SEE ADDITIONAL
SEE INFORMATION

(5) DECK B : TCM-53FMF

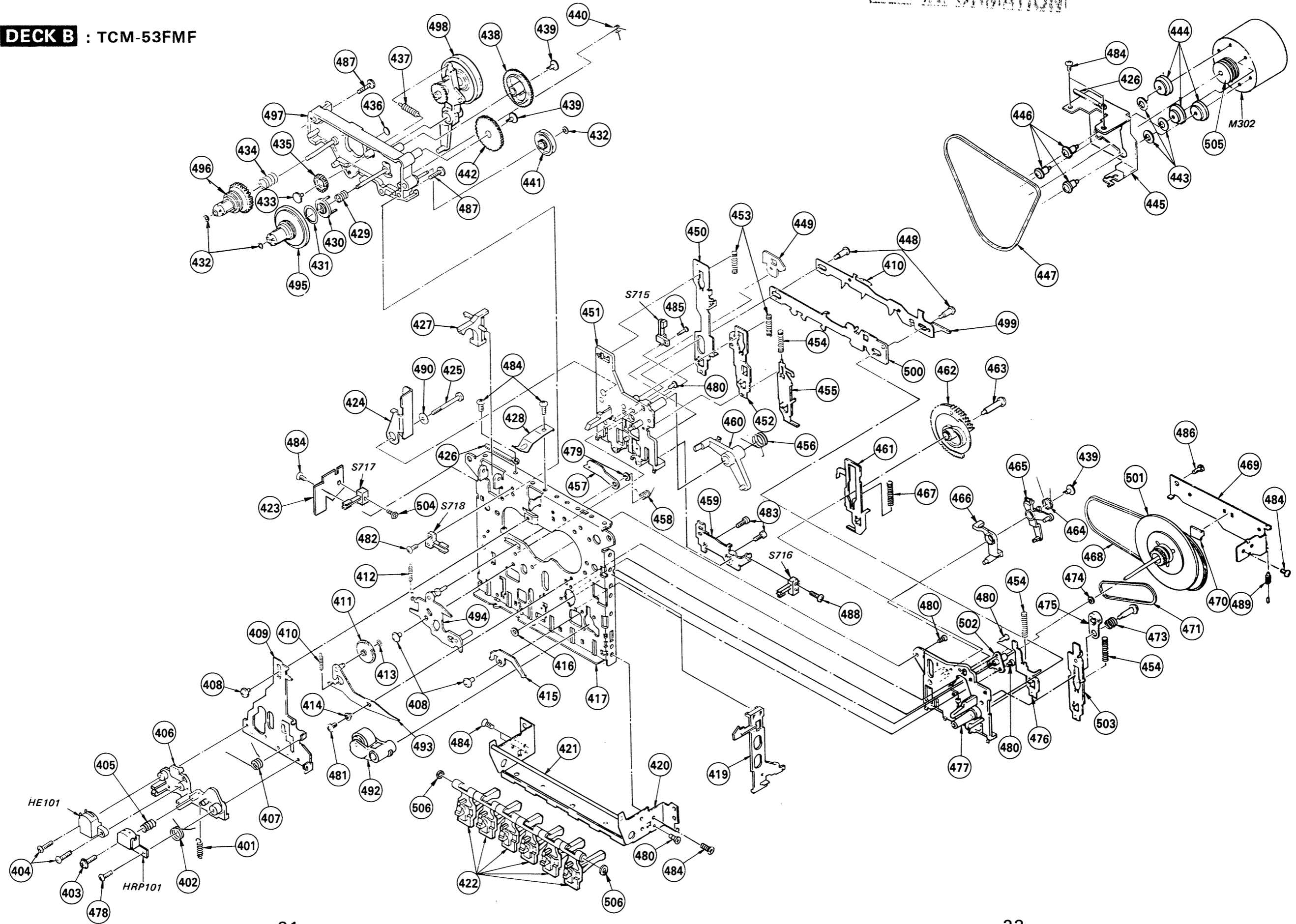

SECTION 5 ELECTRICAL PARTS LIST

NOTE:

- Items marked " * " are not stocked since they are seldom required for routine service. Some delay should be anticipated when ordering these items.
- If there are two or more same circuits in a set such as a stereophonic machine, only typical circuit parts may be indicated and capacitors and resistors in other same circuits may be omitted.

CAPACITORS:

MF:μF, PF:μμF.

RESISTORS

- All resistors are in ohms.
- F : nonflammable

COILS

MMH : mH, UH : μH

SEMICONDUCTORS

In each case, U : μ, for example:

UA....: μA...., UPA....: μPA...., UPC....: μPC, UPD....: μPD....

The components identified by shading and mark **Δ** are critical for safety. Replace only with part number specified.

Les composants identifiés par une trame et une marque **Δ** sont critiques pour la sécurité. Ne les remplacer que par une pièce portant le numéro spécifié.

ELECTRICAL PARTS

Ref.No.	Part No.	Description				
901	*A-2056-320-A	(W230/W233:US)...MOUNTED PCB, AUDIO				
	*A-2056-321-A	(W230:Canadian,AEP,E)..MOUNTED PCB, AUDIO				
	*A-2056-322-A	(W230:UK).....MOUNTED PCB, AUDIO				
	*A-2056-330-A	(W235:E).....MOUNTED PCB, AUDIO				
902	Δ .1-534-817-XX	(W230:AEP)....CORD, POWER				
	Δ .1-551-188-XX	(W230:E).....CORD, POWER				
	Δ .1-551-628-00	(W230:US,Canadian/W233:US)...CORD, POWER				
	Δ .1-556-562-00	(W230:UK).....CORD, POWER				
903	*1-618-741-11	PC BOARD, LCD LEVEL METER				
C101	1-162-287-31	CERAMIC	270PF	10%	50V	
C102	1-136-157-00	FILM	0.022MF	5%	50V	
C103	1-123-330-00	ELECT	22MF	20%	16V	
C104	1-162-292-31	CERAMIC	680PF	10%	50V	
C105	1-136-157-00	FILM	0.022MF	5%	50V	
C106	1-123-330-00	ELECT	22MF	20%	16V	
C107	1-136-158-00	FILM	0.027MF	5%	50V	
C109	1-124-927-11	ELECT	4.7MF	20%	50V	
C110	1-110-203-00	MYLAR	0.0047MF	5%	50V	
C111	1-136-173-00	FILM	0.47MF	5%	50V	
C112	1-136-167-00	FILM	0.15MF	5%	50V	
C113	1-136-155-00	FILM	0.015MF	5%	50V	
C114	1-136-169-00	FILM	0.22MF	5%	50V	
C115	1-136-163-00	FILM	0.068MF	5%	50V	
C116	1-136-161-00	FILM	0.047MF	5%	50V	
C117	1-110-205-00	MYLAR	0.0068MF	5%	50V	
C118	1-136-153-00	FILM	0.01MF	5%	50V	
C121	1-124-183-00	ELECT	2.2MF	20%	50V	
C122	1-124-903-00	ELECT	1MF	20%	50V	
C123	1-110-205-00	MYLAR	0.0068MF	5%	50V	
C124	1-124-899-91	ELECT	22MF	20%	25V	
C125	1-136-163-00	FILM	0.068MF	5%	50V	
C126	1-124-907-00	ELECT	10MF	20%	50V	
C127	1-162-288-31	CERAMIC	330PF	10%	50V	
C128	1-136-273-91	FILM	75PF	5%	630V	
C129	1-110-198-00	MYLAR	0.0018MF	5%	50V	
C130	1-136-153-00	FILM	0.01MF	5%	50V	
C131	1-136-155-00	FILM	0.015MF	5%	50V	
C132	1-110-206-00	MYLAR	0.0082MF	5%	50V	
C133	1-136-153-00	FILM	0.01MF	5%	50V	
C134	1-110-206-00	MYLAR	0.0082MF	5%	50V	
C135	1-124-903-00	ELECT	1MF	20%	50V	
C138	1-110-198-00	MYLAR	0.0018MF	5%	50V	
C301	1-124-468-11	ELECT	100MF	20%	6.3V	
C302	1-124-468-11	ELECT	100MF	20%	6.3V	
C303	1-124-468-11	ELECT	100MF	20%	6.3V	

ELECTRICAL PARTS

Ref.No.	Part No.	Description				
C304	1-124-468-11	ELECT	100MF	20%	6.3V	
C305	1-129-713-00	FILM	0.0082MF	10%	630V	
C306	1-110-206-00	MYLAR	0.0082MF	5%	50V	
C307	1-110-202-00	MYLAR	0.0039MF	5%	50V	
C308	1-110-202-00	MYLAR	0.0039MF	5%	50V	
C309	1-124-903-00	ELECT	1MF	20%	50V	
C310	1-124-902-00	ELECT	0.47MF	20%	50V	
C311	1-124-904-00	ELECT	2.2MF	20%	50V	
C313	1-136-161-00	FILM	0.047MF	5%	50V	
C314	1-123-343-00	ELECT	33MF	20%	25V	
C399	1-162-113-00	(W230/W233)...CERAMIC	0.01MF	30%	16V	
C501	1-124-563-11	(W235).....ELECT	2200MF	20%	25V	
C501	1-124-636-00	(W230/W233)...ELECT	3300MF	20%	25V	
C502	1-124-563-11	(W235).....ELECT	2200MF	20%	25V	
C502	1-124-636-00	(W230/W233)...ELECT	3300MF	20%	25V	
C503	1-124-478-11	ELECT	100MF	20%	25V	
C504	1-124-478-11	ELECT	100MF	20%	25V	
C505	1-124-471-00	ELECT	1000MF	20%	6.3V	
C506	1-124-471-00	ELECT	1000MF	20%	6.3V	
C507	1-124-899-91	ELECT	22MF	20%	25V	
C701	1-124-903-00	ELECT	1MF	20%	50V	
C702	1-124-905-91	ELECT	3.3MF	20%	50V	
C703	1-124-905-91	ELECT	3.3MF	20%	50V	
C708	1-162-294-31	CERAMIC	0.001MF	10%	50V	
C709	1-124-904-00	ELECT	2.2MF	20%	50V	
C710	1-162-306-31	CERAMIC	0.01MF	30%	16V	
C712	1-124-906-11	ELECT	4.7MF	20%	50V	
C791	1-124-927-11	ELECT	4.7MF	20%	50V	
C801	1-124-903-00	ELECT	1MF	20%	50V	
C802	1-124-904-00	ELECT	2.2MF	20%	50V	
C851	1-124-903-00	ELECT	1MF	20%	50V	
C852	1-124-904-00	ELECT	2.2MF	20%	50V	
C891	1-110-204-00	MYLAR	0.0056MF	5%	50V	
C892	1-124-892-91	ELECT	47MF	20%	10V	
CNP301*	1-560-061-00	PIN, CONNECTOR 3P				
CNP302*	1-560-064-00	PIN, CONNECTOR 6P				
CNP303*	1-564-505-31	PLUG, CONNECTOR 2P				
CNP502	1-564-067-00	(W235)...SOCKET, CONNECTOR 5P				
CNP701*	1-560-066-00	PIN, CONNECTOR 10P				
CNP702*	1-560-230-00	PIN, CONNECTOR 12P				
CNP801*	1-564-521-11	PLUG, CONNECTOR 6P				
CT301	1-141-225-00	CAP, TUNING, TRIMMER				
D301	8-719-107-94	DIODE 1SS202-1				
D302	8-719-107-94	DIODE 1SS202-1				
D303	8-719-107-94	DIODE 1SS202-1				

TC-W230/W233/W235

ELECTRICAL PARTS

Ref.No.	Part No.	Description
D501	8-719-200-77	(W230:US,Canadian,AEP ,E/W233/W235)
D502	8-719-200-77	(W230:US,Canadian,AEPDIODE 10E2N ,E/W233/W235)
D503	8-719-200-77	(W230:US,Canadian,AEPDIODE 10E2N ,E/W233/W235)
D504	8-719-200-77	(W230:US,Canadian,AEPDIODE 10E2N ,E/W233/W235)
D505	8-719-910-61	DIODE HZ6A1L
D506	8-719-910-64	(W230/W233)...DIODE HZ6B1L
D590	8-719-502-20	(W230:UK).....DIODE S2VB20
D701	8-719-107-94	DIODE 1SS202-1
D702	8-719-107-94	DIODE 1SS202-1
D703	8-719-107-94	DIODE 1SS202-1
D704	8-719-107-94	DIODE 1SS202-1
D705	8-719-107-94	DIODE 1SS202-1
D706	8-719-107-94	DIODE 1SS202-1
D707	8-719-107-94	DIODE 1SS202-1
D708	8-719-107-94	DIODE 1SS202-1
D709	8-719-107-94	DIODE 1SS202-1
D710	8-719-107-94	DIODE 1SS202-1
D711	8-719-107-94	DIODE 1SS202-1
D712	8-719-107-94	DIODE 1SS202-1
D713	8-719-107-94	DIODE 1SS202-1
D714	8-719-107-94	DIODE 1SS202-1
D716	8-719-107-94	DIODE 1SS202-1
D717	8-719-107-94	DIODE 1SS202-1
D718	8-719-107-94	DIODE 1SS202-1
D719	8-719-107-94	DIODE 1SS202-1
D725	8-719-107-94	DIODE 1SS202-1
D726	8-719-107-94	(W230/W233)...DIODE 1SS202-1
D728	8-719-107-94	DIODE 1SS202-1
D761	8-719-302-74	DIODE SEL2210W-C
D762	8-719-302-74	DIODE SEL2210W-C
D763	8-719-302-74	DIODE SEL2210W-C
IC301	8-759-602-01	IC M5220P
IC302	8-759-602-01	IC M5220P
IC303	8-752-018-70	IC CX20187
IC305	8-759-145-58	IC UPC4558C
IC306	8-759-140-66	IC UPD4066BC
IC308	8-759-600-02	(W230/W233)...IC M5218L
IC701	8-759-140-11	IC UPD4011BC
IC702	8-759-140-11	IC UPD4011BC
IC703	8-759-140-69	IC UPD4069UBC
IC801	8-752-321-65	IC CXD1017Q
J301	1-507-908-11	JACK, PIN 4P (LINE IN/OUT)
J302	1-563-249-11	(W230/W233)...JACK, LARGE TYPE (HEADPHONES)
L101	1-408-923-00	MICRO INDUCTOR 8.2MMH
L102	1-408-919-11	MICRO INDUCTOR 3.9MMH
L103	1-408-929-00	MICRO INDUCTOR 27MMH
L201	1-408-923-00	MICRO INDUCTOR 8.2MMH
L202	1-408-919-11	MICRO INDUCTOR 3.9MMH
L203	1-408-929-00	MICRO INDUCTOR 27MMH
LCD801	1-520-488-11	METER, LEVEL
LPF101	1-231-388-00	FILTER, LOW PASS
LPF201	1-231-388-00	FILTER, LOW PASS

ELECTRICAL PARTS

Ref.No.	Part No.	Description
PL801	1-518-596-11	LAMP, PILOT (6V/150mA)
PL802	1-518-596-11	LAMP, PILOT (6V/150mA)
Q101	8-729-606-33	TRANSISTOR 2SC2603F
Q102	8-729-606-33	TRANSISTOR 2SC2603F
Q103	8-729-606-33	(W230/W235)...TRANSISTOR 2SC2603F
Q104	8-729-606-33	TRANSISTOR 2SC2603F
Q105	8-729-606-33	TRANSISTOR 2SC2603F
Q106	8-729-606-33	TRANSISTOR 2SC2603F
Q107	8-729-606-33	TRANSISTOR 2SC2603F
Q201	8-729-606-33	TRANSISTOR 2SC2603F
Q202	8-729-606-33	TRANSISTOR 2SC2603F
Q203	8-729-606-33	(W230/W235)...TRANSISTOR 2SC2603F
Q204	8-729-606-33	TRANSISTOR 2SC2603F
Q205	8-729-606-33	TRANSISTOR 2SC2603F
Q206	8-729-606-33	TRANSISTOR 2SC2603F
Q207	8-729-606-33	TRANSISTOR 2SC2603F
Q301	8-729-900-89	TRANSISTOR DTC144ES
Q303	8-729-117-54	TRANSISTOR 2SA1175
Q304	8-729-117-54	TRANSISTOR 2SA1175
Q305	8-729-117-54	TRANSISTOR 2SA1175
Q306	8-729-606-33	TRANSISTOR 2SC2603F
Q307	8-729-178-54	TRANSISTOR 2SC2785
Q308	8-729-194-57	TRANSISTOR 2SC945-P
Q309	8-729-194-57	TRANSISTOR 2SC945-P
Q310	8-729-117-54	TRANSISTOR 2SA1175
Q501	8-729-107-25	TRANSISTOR 2SD1585-L
Q502	8-729-111-67	TRANSISTOR 2SB1094-L
Q503	8-729-178-54	TRANSISTOR 2SC2785
Q504	8-729-117-54	TRANSISTOR 2SA1175
Q505	8-729-178-54	TRANSISTOR 2SC2785
Q506	8-729-117-54	TRANSISTOR 2SA1175
Q701	8-729-606-33	TRANSISTOR 2SC2603F
Q702	8-729-801-83	TRANSISTOR 2SB1013
Q704	8-729-900-65	TRANSISTOR DTA144ES
Q705	8-729-900-65	TRANSISTOR DTA144ES
Q706	8-729-900-65	TRANSISTOR DTA144ES
R101	1-247-889-00	CARBON 270K 5% 1/6W
R102	1-249-405-11	CARBON 100 5% 1/6W
R103	1-247-882-00	CARBON 130K 5% 1/6W
R104	1-247-849-00	CARBON 5.6K 5% 1/6W
R105	1-249-419-11	CARBON 1.5K 5% 1/6W
R106	1-247-841-00	CARBON 2.7K 5% 1/6W
R107	1-247-887-00	CARBON 220K 5% 1/6W
R108	1-247-889-00	CARBON 270K 5% 1/6W
R109	1-249-405-11	CARBON 100 5% 1/6W
R110	1-247-882-00	CARBON 130K 5% 1/6W
R111	1-247-849-00	CARBON 5.6K 5% 1/6W
R112	1-249-433-11	CARBON 22K 5% 1/6W
R113	1-247-843-00	CARBON 3.3K 5% 1/6W
R114	1-247-851-00	CARBON 6.8K 5% 1/6W
R115	1-247-840-00	CARBON 2.4K 5% 1/6W
R116	1-247-846-00	CARBON 4.3K 5% 1/6W
R117	1-247-822-00	CARBON 430 5% 1/6W
R118	1-247-851-00	CARBON 6.8K 5% 1/6W
R119	1-249-415-11	CARBON 680 5% 1/6W
R120	1-249-421-11	CARBON 2.2K 5% 1/6W
R121	1-247-831-00	CARBON 1K 5% 1/6W

ELECTRICAL PARTS

Ref.No.	Part No.	Description			
R122	1-249-434-11	CARBON	27K	5%	1/6W
R123	1-247-843-00	CARBON	3.3K	5%	1/6W
R128	1-249-421-11	CARBON	2.2K	5%	1/6W
R130	1-249-433-11	CARBON	22K	5%	1/6W
R131	1-249-429-11	(W230/W233)...CARBON	10K	5%	1/6W
R132	1-247-831-00	(W230/W233)...CARBON	1K	5%	1/6W
R133	1-247-857-00	(W230/W233)...CARBON	12K	5%	1/6W
R134	1-249-429-11	(W230/W233)...CARBON	10K	5%	1/6W
R135	1-247-815-00	(W230/W233)...CARBON	220	5%	1/6W
R136	1-249-429-11	CARBON	10K	5%	1/6W
R137	1-247-849-00	CARBON	5.6K	5%	1/6W
R138	1-247-851-00	CARBON	6.8K	5%	1/6W
R139	1-249-434-11	CARBON	27K	5%	1/6W
R140	1-249-435-11	CARBON	33K	5%	1/6W
R141	1-247-841-00	CARBON	2.7K	5%	1/6W
R142	1-249-433-11	CARBON	22K	5%	1/6W
R143	1-249-433-11	CARBON	22K	5%	1/6W
R144	1-247-815-00	CARBON	220	5%	1/6W
R145	1-247-817-00	CARBON	270	5%	1/6W
R146	1-247-858-00	CARBON	13K	5%	1/6W
R147	1-249-429-11	CARBON	10K	5%	1/6W
R148	1-247-846-00	CARBON	4.3K	5%	1/6W
R149	1-249-433-11	CARBON	22K	5%	1/6W
R150	1-247-819-00	CARBON	330	5%	1/6W
R151	1-247-858-00	CARBON	13K	5%	1/6W
R152	1-247-837-00	CARBON	1.8K	5%	1/6W
R153	1-247-845-00	CARBON	3.9K	5%	1/6W
R154	1-247-846-00	CARBON	4.3K	5%	1/6W
R155	1-247-887-00	CARBON	220K	5%	1/6W
R156	1-247-887-00	CARBON	220K	5%	1/6W
R157	1-247-857-00	CARBON	12K	5%	1/6W
R159	1-249-435-11	CARBON	33K	5%	1/6W
R161	1-247-843-00	CARBON	3.3K	5%	1/6W
R162	1-249-429-11	CARBON	10K	5%	1/6W
R164	1-247-819-00	CARBON	330	5%	1/6W
R165	1-249-421-11	CARBON	2.2K	5%	1/6W
R301	1-247-708-11	CARBON	470	5%	1/4W
R302	1-247-708-11	CARBON	470	5%	1/4W
R303	1-247-708-11	CARBON	470	5%	1/4W
R304	1-247-708-11	CARBON	470	5%	1/4W
R305	1-249-429-11	CARBON	10K	5%	1/6W
R306	1-249-437-11	CARBON	47K	5%	1/6W
R307	1-249-433-11	CARBON	22K	5%	1/6W
R308	1-249-433-11	CARBON	22K	5%	1/6W
R309	1-249-433-11	CARBON	22K	5%	1/6W
R310	1-215-469-00	METAL	100K	1%	1/6W
R311	1-247-815-00	CARBON	220	5%	1/6W
R312	1-247-843-00	CARBON	3.3K	5%	1/6W
R313	1-249-425-11	CARBON	4.7K	5%	1/6W
R314	1-249-425-11	CARBON	4.7K	5%	1/6W
R315	1-249-433-11	CARBON	22K	5%	1/6W
R316	1-249-433-11	CARBON	22K	5%	1/6W
R317	1-249-433-11	CARBON	22K	5%	1/6W
R318	1-249-429-11	CARBON	10K	5%	1/6W
R319	1-212-857-91	FUSIBLE	10	5%	1/4W
R320	1-249-435-11	CARBON	33K	5%	1/6W
R322	1-249-429-11	CARBON	10K	5%	1/6W

ELECTRICAL PARTS

Ref.No.	Part No.	Description			
R323	1-247-887-00	CARBON	220K	5%	1/6W
R324	1-249-433-11	(W235)...CARBON	22K	5%	1/6W
R501	1-247-831-00	CARBON	1K	5%	1/6W
R502	1-247-831-00	CARBON	1K	5%	1/6W
R503	1-247-823-00	CARBON	470	5%	1/6W
R504	1-247-823-00	CARBON	470	5%	1/6W
R505	1-247-831-00	CARBON	1K	5%	1/6W
R506	1-247-843-00	CARBON	3.3K	5%	1/6W
R507	1-247-841-00	CARBON	2.7K	5%	1/6W
R508	1-249-421-11	(W230/W235)...CARBON	2.2K	5%	1/6W
R509	1-247-831-00	(W230/W235)...CARBON	1K	5%	1/6W
R510	1-247-831-00	CARBON	1K	5%	1/6W
R511	1-217-422-00	(W235).....FUSIBLE	1	5%	1/2W
R511	1-244-801-00	(W230/W233:US)...CARBON	1	5%	1/2W
R701	1-249-429-11	CARBON	10K	5%	1/6W
R702	1-249-437-11	CARBON	47K	5%	1/6W
R703	1-249-437-11	CARBON	47K	5%	1/6W
R704	1-249-435-11	CARBON	33K	5%	1/6W
R705	1-249-437-11	CARBON	47K	5%	1/6W
R706	1-247-895-00	CARBON	470K	5%	1/6W
R707	1-247-875-00	CARBON	68K	5%	1/6W
R708	1-249-435-11	CARBON	33K	5%	1/6W
R709	1-247-875-00	CARBON	68K	5%	1/6W
R710	1-249-437-11	CARBON	47K	5%	1/6W
R711	1-249-435-11	CARBON	33K	5%	1/6W
R712	1-249-433-11	CARBON	22K	5%	1/6W
R713	1-249-419-11	CARBON	1.5K	5%	1/6W
R714	1-249-437-11	CARBON	47K	5%	1/6W
R715	1-247-887-00	CARBON	220K	5%	1/6W
R717	1-247-891-00	CARBON	330K	5%	1/6W
R718	1-249-435-11	CARBON	33K	5%	1/6W
R719	1-247-889-00	CARBON	270K	5%	1/6W
R720	1-249-435-11	CARBON	33K	5%	1/6W
R721	1-249-435-11	CARBON	33K	5%	1/6W
R722	1-249-435-11	CARBON	33K	5%	1/6W
R723	1-249-435-11	CARBON	33K	5%	1/6W
R724	1-249-435-11	CARBON	33K	5%	1/6W
R725	1-249-435-11	CARBON	33K	5%	1/6W
R726	1-249-435-11	CARBON	33K	5%	1/6W
R727	1-247-833-00	CARBON	1.2K	5%	1/6W
R728	1-247-833-00	CARBON	1.2K	5%	1/6W
R729	1-247-833-00	CARBON	1.2K	5%	1/6W
R730	1-249-425-11	CARBON	4.7K	5%	1/6W
R731	1-249-425-11	CARBON	4.7K	5%	1/6W
R732	1-247-849-00	CARBON	5.6K	5%	1/6W
R734	1-249-429-11	CARBON	10K	5%	1/6W
R735	1-247-849-00	CARBON	5.6K	5%	1/6W
R737	1-249-429-11	CARBON	10K	5%	1/6W
R749	1-249-405-11	CARBON	100	5%	1/6W
R791	1-247-823-00	CARBON	470	5%	1/6W
R801	1-247-872-00	CARBON	51K	5%	1/6W
R802	1-249-437-11	CARBON	47K	5%	1/6W
R803	1-247-903-00	CARBON	1M	5%	1/6W
R851	1-247-872-00	CARBON	51K	5%	1/6W
R852	1-249-437-11	CARBON	47K	5%	1/6W
R853	1-247-903-00	CARBON	1M	5%	1/6W

TC-W230/W233/W235

ELECTRICAL PARTS

ACCESSORY & PACKING MATERIAL

Ref.No.	Part No.	Description
R891	1-247-893-00	CARBON 390K 5% 1/6W
R893	1-247-815-00	CARBON 220 5% 1/6W
R894	1-247-834-00	CARBON 1.3K 5% 1/6W
R895	1-249-441-11	CARBON 100K 5% 1/6W
RV101	1-228-989-00	RES, ADJ, CARBON 470
RV102	1-228-989-00	RES, ADJ, CARBON 470
RV103	1-228-994-00	RES, ADJ, CARBON 10K
RV104	1-237-204-21	RES, VAR, SLIDE 20K
RV201	1-228-989-00	RES, ADJ, CARBON 470
RV202	1-228-989-00	RES, ADJ, CARBON 470
RV203	1-228-994-00	RES, ADJ, CARBON 10K
RV204	1-237-204-21	RES, VAR, SLIDE 20K
RV701	1-228-993-00	RES, ADJ, CARBON 4.7K
RV702	1-228-993-00	RES, ADJ, CARBON 4.7K
RV703	1-228-993-00	RES, ADJ, CARBON 4.7K
RV704	1-228-993-00	RES, ADJ, CARBON 4.7K
S301	1-570-531-11	SWITCH, PUSH (2 KEY)(DOLBY NR)
S302	1-570-655-11	SWITCH, PUSH (3 KEY)(TAPE)
S303	1-554-033-00	SWITCH, SLIDE (RECORD/PLAYBACK)
S501	1-570-103-11	(W230/W233)..SWITCH, PUSH(1 KEY)(POWER)
S701	1-570-530-11	SWITCH, PUSH (2 KEY) (HIGH SPEED/NORMAL SPEED)
S901	1-570-307-11	(W230:E).....SWITCH, VOLTAGE CHANGE
SPK101	1-235-186-00	ENCAPSULATED COMPONENT
SPK201	1-235-186-00	ENCAPSULATED COMPONENT
T301	1-433-303-11	TRANSFORMER, BIAS OSCILLATION
T501	1-448-497-11	(W230:E).....TRANSFORMER, POWER
T501	1-448-498-11	(W230:US,Canadian/W233:US) ...TRANSFORMER, POWER
T501	1-448-499-11	(W230:AEP,UK)...TRANSFORMER, POWER
TP701	*1-564-505-31	PLUG, CONNECTOR 2P

Part No.	Description
1-558-543-11	CORD, CONNECTION
3-332-447-01	(W230)...INDIVIDUAL CARTON
3-332-447-11	(W233)...INDIVIDUAL CARTON
3-332-448-01	(W230/W233)..CUSHION
3-701-630-00	(W230/W233)...BAG, POLYETHYLENE
3-703-450-01	(W230/W233:US)...INSTRUCTION
3-703-680-00	LABEL, CAUTION, SUB, NEW UL
3-703-713-41	STICKER, SONY SYMBOL (10)
3-765-169-11	(W230/W233:AEP,UK,E)...MANUAL, INSTRUCTION
3-765-169-21	(W230/W233:US,Canadian) ...MANUAL, INSTRUCTION
3-765-169-31	(W230/W233:Canadian)...MANUAL, INSTRUCTION
3-765-169-41	(W230/W233:AEP).....MANUAL, INSTRUCTION
4-876-352-00	(W230/W233)...SHEET, PROTECTION

● Semiconductor Lead Layouts

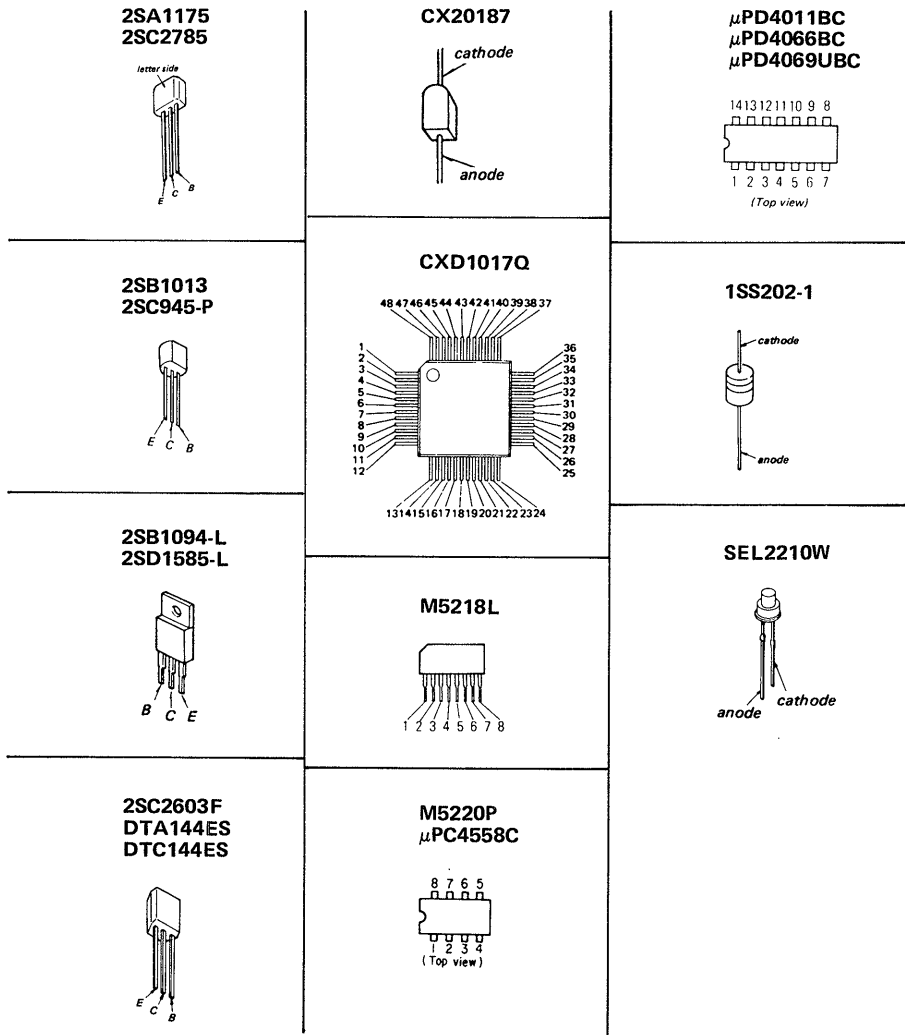

SECTION 6 DIAGRAMS

4-1. MOUNTED DIAGRAM

— Conductor Side —

- See page 27 for Semiconductor Lead Layouts.

SEMICONDUCTOR LOCATION

Ref. No.	Location	Ref. No.	Location
D301	B-10	Q101	C-8
D302	F-9	Q102	A-6
D303	F-11	Q103	E-10
D501	B-15	Q104	F-8
D502	B-15	Q105	F-9
D503	A-15	Q106	I-10
D504	A-15	Q107	I-9
D505	B-12	Q201	C-7
D506	B-13	Q202	A-7
D590	A-14	Q203	E-10
D701	F-14	Q204	F-6
D702	E-14	Q205	F-6
D703	F-15	Q206	I-10
D704	E-15	Q207	I-9
D705	D-14	Q301	B-10
D706	E-12	Q302	A-7
D707	D-12	Q303	E-10
D708	E-13	Q304	E-11
D709	E-13	Q305	I-10
D710	E-13	Q306	C-12
D711	D-12	Q307	C-12
D712	D-12	Q308	C-12
D713	D-14	Q309	C-13
D714	E-13	Q310	D-12
D716	D-14	Q501	C-17
D717	D-15	Q502	A-17
D718	D-15	Q503	B-12
D719	D-15	Q504	A-12
D725	B-15	Q505	A-12
D726	C-14	Q506	A-12
D728	F-14	Q701	F-15
D761	J-13	Q702	E-15
D762	J-14	Q704	E-14
D763	J-15	Q705	D-15
		Q706	C-15
IC301	B-8		
IC302	D-10		
IC303	D-7		
IC305	F-7		
IC306	B-9		
IC308	F-9		
IC701	F-14		
IC702	F-13		
IC703	D-13		
IC801	G-3		

Note:

- Color code or sleeving over the end of the jacket.

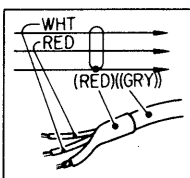

- : parts extracted from the component side.
- : part mounted on the conductor side.
- : indicates side identified with part number.

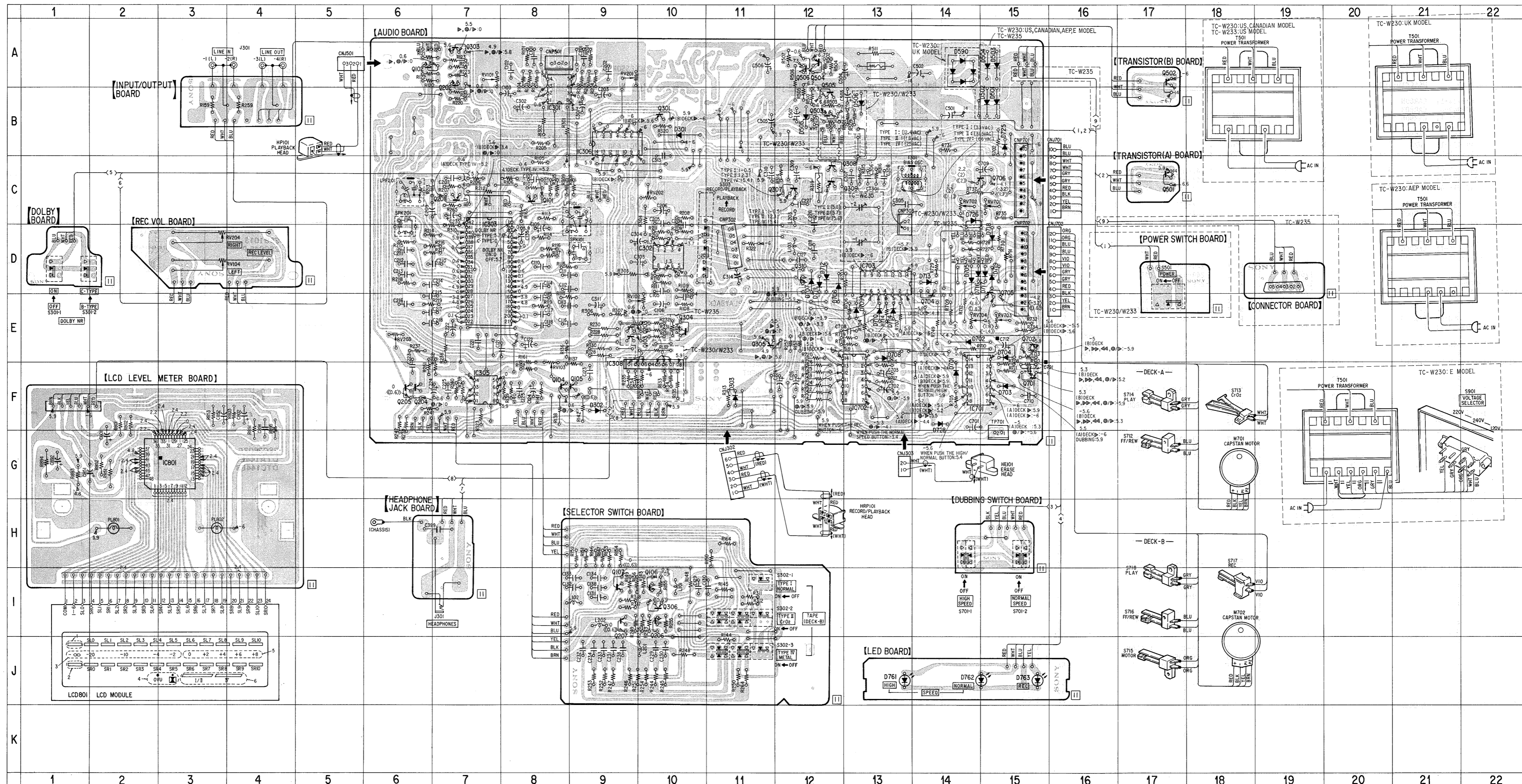

SONY
STEREO CASSETTE DECK
TC-W230/W233/W235

US Model
Canadian Model
AEP Model
UK Model
E Model

(TC-W230/W233/W235)

TC-W230/W233

SCHEMATIC DIAGRAM

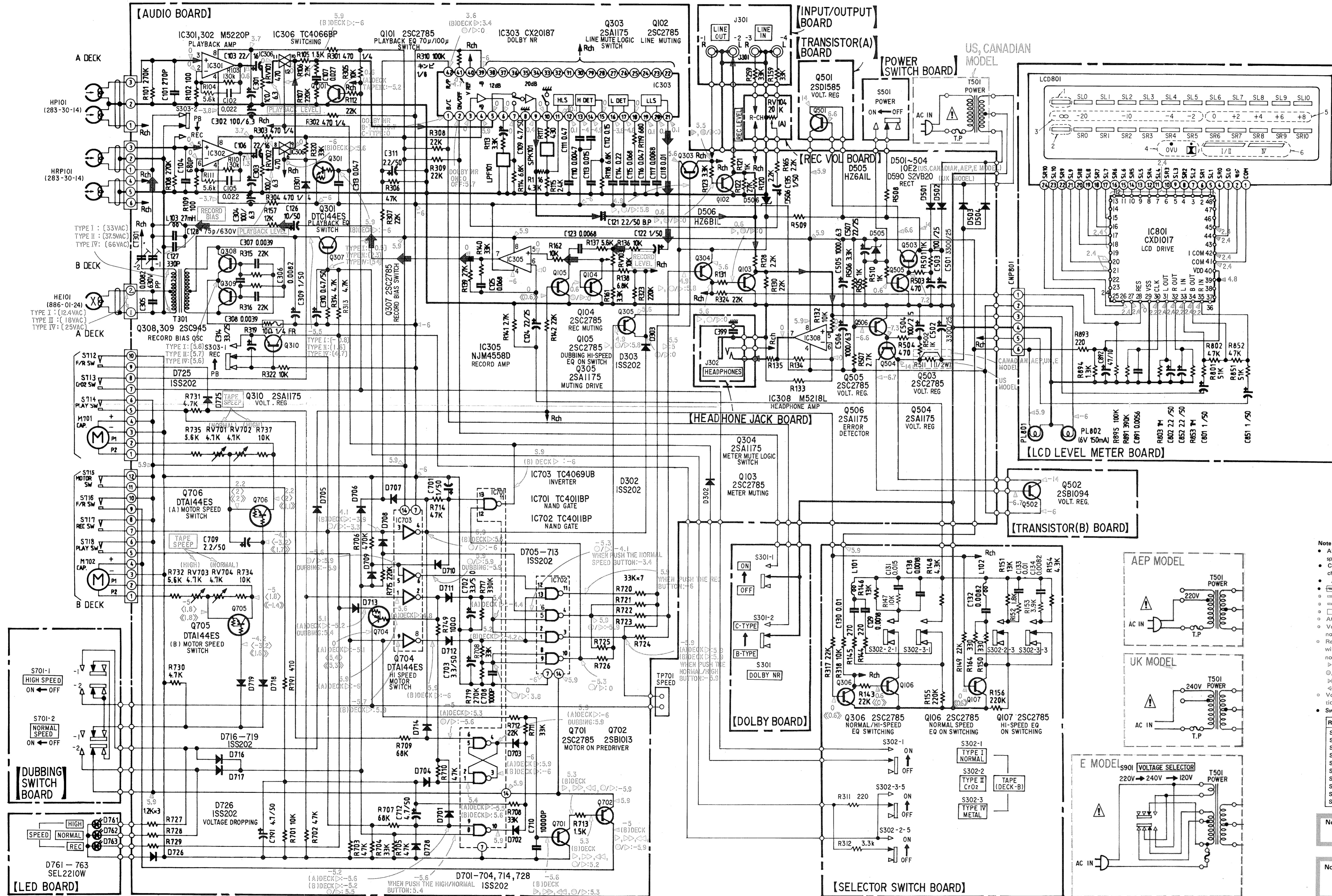

Note:

- All resistors are in Ω and $\frac{1}{2}W$ or less unless otherwise specified.
- Components for right channel have same values as for left channel. Reference numbers are coded from 200.
- Δ : internal component.
- \square : fusible resistor.
- $\text{---} \text{---}$: B+ bus.
- $\text{---} \text{---}$: B- bus.
- \square : adjustment for repair.
- AC voltage readings in the bias oscillator with a VTVM.
- Voltages are dc with respect to ground unless otherwise noted.
- Readings are taken under no-signal (detuned) conditions with a VOM (50 k Ω /V).
- no mark: STOP > NORMAL SPEED <
- >: PLAY <<: HIGH SPEED
- >|>: REC <<|<: REW
- <<: FF
- Voltage variations may be noted due to normal production tolerances.

Switch

Ref. No.	Switch	Position
S301-1	DOLBY NR	ON/OFF
S301-2	DOLBY NR B TYPE/C TYPE	B TYPE
S302-1	TYPE I (NORMAL)	OFF
S302-2	TYPE II (C.O.)	OFF
S302-3	TYPE IV (METAL)	OFF
S303	Record/Playback	Playback
S501	POWER	OFF
S701-1	HIGH SPEED	OFF
S701-2	NORMAL SPEED	OFF
S901	VOLTAGE SELECTOR	220V

Note: The components identified by shading and mark Δ are critical for safety. Replace only with part number specified.

Note: Les composants identifiés par un trame et une marque Δ sont critiques pour la sécurité. Ne les remplacer que par une pièce portant le numéro spécifié.

• \rightarrow : playback signal.
• \bullet : record signal.

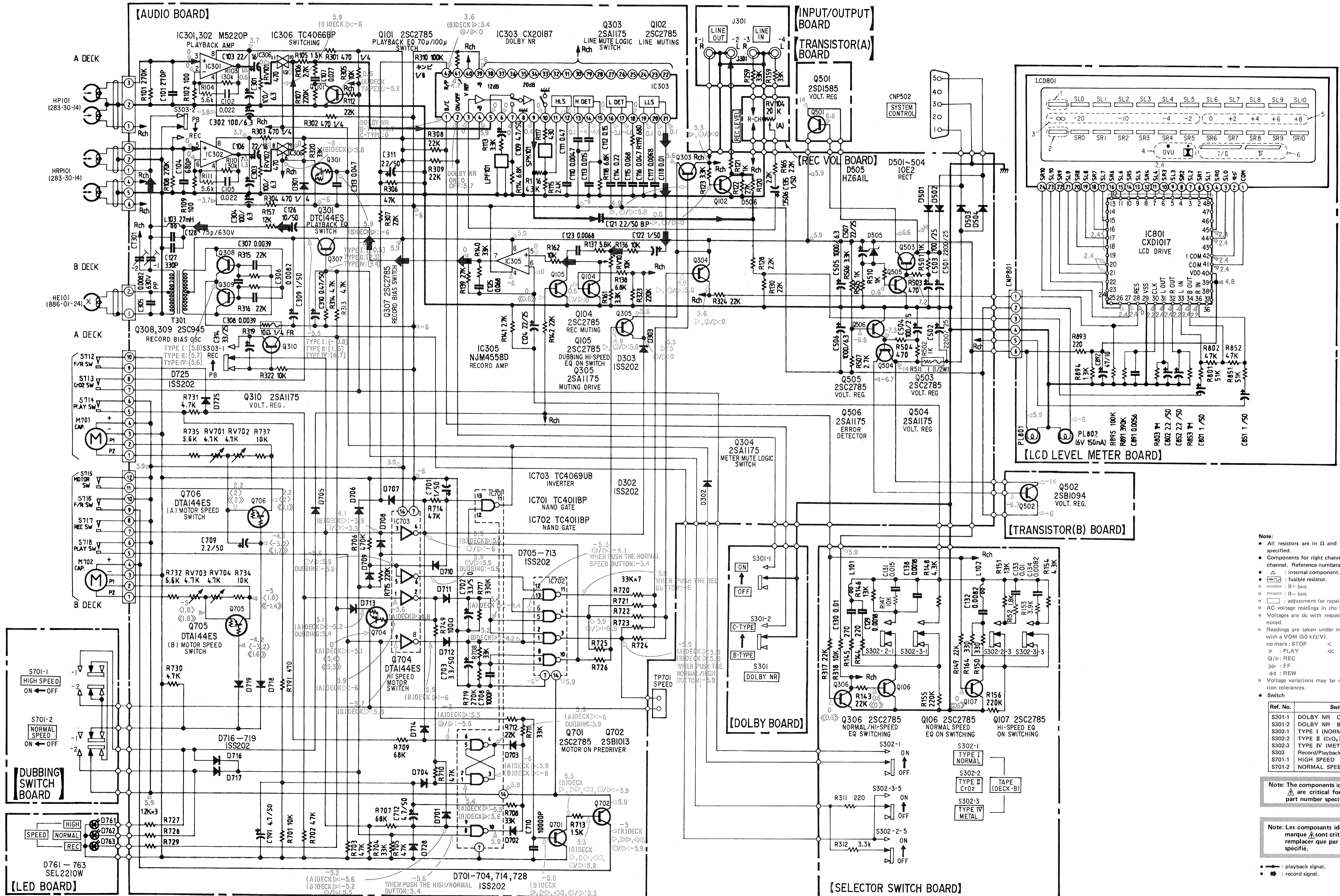

Note:

- All resistors are in Ω and $\frac{1}{2}W$ or less unless otherwise specified.
- Components for right channel have same values as for left channel. Reference numbers are coded from 200.
- Δ : internal component.
- \square : fusible resistor.
- \circ : B+ bus.
- \square : adjustment for repair.
- AC voltage readings in the bias oscillator with a VTVM.
- Voltages are dc with respect to ground unless otherwise noted.
- Readings are taken under no-signal (detuned) conditions with a VOM (50 k Ω /V).
- no mark: STOP < >: NORMAL SPEED
- >: PLAY << >>: HIGH SPEED
- >>>: FF
- <<<: REW
- Voltage variations may be noted due to normal production tolerances.

Switch

Ref. No.	Switch	Position
S301-1	DOLBY NR ON/OFF	OFF
S301-2	DOLBY NR B TYPE/C TYPE	B TYPE
S302-1	TYPE I (NORMAL)	OFF
S302-2	TYPE II (C ₀ -)	OFF
S302-3	TYPE IV (METAL)	OFF
S303	Record/Playback	Playback
S701-1	HIGH SPEED	OFF
S701-2	NORMAL SPEED	OFF

Note: The components identified by shading and mark Δ are critical for safety. Replace only with part number specified.

Note: Les composants identifiés par un trame et une marque Δ sont critiques pour la sécurité. Ne les remplacer que par une pièce portant le numéro spécifié.

● → : playback signal.
 ● → : record signal.

LEAF SWITCH LAYOUTS

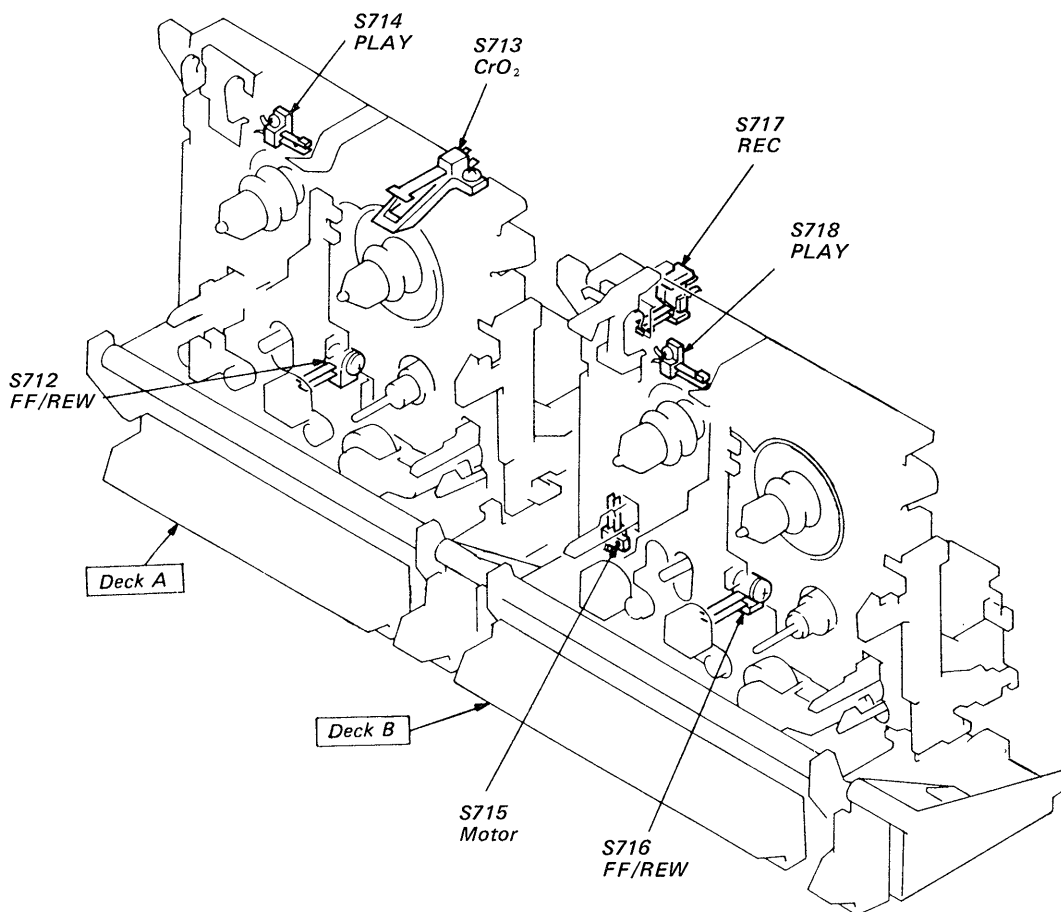

● ON/OFF state of leaf switches at each mode

mode Switch	STOP	FWD		FF or REW		REC	TAPE DUBBING
		Deck A	Deck B	Deck A	Deck B		
S714 (PLAY)	—	ON	—	—	—	—	ON
S712 (FF/REW)	—	—	—	ON	—	—	—
S715 (motor)	—	—	ON	—	ON	ON	ON
S718 (PLAY)	—	—	ON	—	—	ON	ON
S717 (REC)	—	—	—	—	—	ON	ON
S716 (FF/REW)	—	—	—	—	ON	—	—

— mark indicates OFF state.

TC-W230/W233/W235

SONY[®] SERVICE MANUAL

US Model
Canadian Model
AEP Model
UK Model
E Model

TC-W230

US Model

TC-W233

E Model

TC-W235

SUPPLEMENT-1

File this supplement with the Service Manual.

Information changes in Service Manual for parts list.

Tape Transport Mechanism Type	DECK A	TCM-54FMF
	DECK B	TCM-53FMF

TCM-54FMF (DECK A)

No.	Part No.	Description
301	3-595-956-01	SPRING
302	3-595-955-01	SPRING
303	3-595-972-01	SCREW (2X9), WASHER HEAD
304	3-596-016-01	SCREW (2X8.5), BINDING
305	3-595-986-01	GUIDE, TAPE
306	3-595-954-01	SPRING
307	*3-595-926-01	BASE, HEAD
308	3-595-953-01	SPRING
309	3-595-964-01	SCREW (A)
310	*3-595-912-01	CHASSIS, HEAD
311	3-595-951-01	SPRING
312	3-595-941-01	IDLER, PLAY
313	3-595-969-01	WASHER, POLYSLIDER
314	3-595-946-01	SPRING (C)
315	*3-595-901-01	CHASSIS
316	3-595-916-01	SPRING
318	3-595-932-01	LEVER (F), EJECT
320	*3-595-920-01	SHAFT (SO), BUTTON
321	*3-596-020-01	HOLDER (B), BUTTON
322	*3-596-018-01	COLLAR, BUTTON
323	3-595-933-01	LEVER, BUTTON
324	3-595-919-01	COLLAR
325	3-558-708-11	WASHER, OIL STOP
326	3-595-961-01	SPRING
327	3-595-938-01	CLUTCH, AUTO
328	3-595-968-01	FELT, AUTO CLUTCH
329	3-558-708-11	WASHER, STOPPER
330	3-595-957-01	SPRING
331	3-595-928-01	BUSHING
332	3-595-927-01	GEAR, FF
333	3-596-013-01	WASHER (5.6X0.19), LUMILER
334	3-595-963-01	SPRING
335	3-595-937-01	GEAR, AUTO CAM
336	3-595-934-01	BUSHING
337	3-595-960-01	SPRING
338	3-595-935-01	PULLEY, AUTO
339	3-595-936-01	GEAR, AUTO
340	3-515-973-01	SCREW, MOTOR
341	*3-596-004-01	CLAMP, CORD
342	3-596-011-01	WASHER (B)
343	3-595-945-01	CUSHION, MOTOR
344	*3-596-024-01	HOLDER, MOTOR
345	3-596-010-01	BELT, FR
346	3-595-965-01	SCREW (B)
347	3-595-929-01	GEAR (C)
348	3-595-967-01	SCREW (D)
349	*3-595-904-01	LEVER (H), FF
350	3-595-947-01	SPRING
351	3-595-939-01	ARM (B), AUTO
352	3-595-940-01	ARM, AUTO LOCK
353	3-595-962-01	SPRING
354	3-595-998-01	BELT, DRIVE
355	*3-595-995-01	BRACKET, FLYWHEEL
356	3-595-959-01	SPRING
357	3-595-931-01	SPACER, CAPSTAN

TCM-54FMF (DECK A)

No.	Part No.	Description
358	3-595-944-01	BELT, AUTO
359	3-701-437-21	WASHER, POLY-SLIDER
360	3-595-966-01	SCREW (C)
361	3-595-948-01	SPRING
362	*3-595-991-01	LEVER, STOP
363	3-595-922-01	HOLDER (A), LEVER
364	*3-595-913-01	PROTECTOR, SWITCH
365	*3-595-906-01	BRACKET, SOLENOID
366	3-595-983-01	SPRING
367	3-595-930-01	ARM (H), LOCK
368	*3-595-905-01	LEVER (H), REW
369	3-595-949-01	SPRING
370	*3-595-909-01	LEVER (B), PLAY
371	3-595-923-01	HOLDER (B), LEVER
372	*3-595-918-01	ARM, INTERLOCK
373	7-621-772-40	SCREW +B 2X8
374	7-685-781-01	SCREW +PTT 2X4 (S)
375	7-685-782-01	SCREW +PTT 2X5 (S)
376	7-685-783-01	SCREW +PTT 2X6 (S)
377	7-685-786-01	SCREW +PTT 2X12 (S)
378	7-685-790-01	SCREW +PTT 2.6X4 (S)
379	7-685-791-01	SCREW +PTT 2.6X5 (S)
380	7-685-792-01	SCREW +PTT 2.6X6 (S)
381	7-685-863-01	SCREW +BVTT 2.6X8 (S)
382	7-685-864-01	SCREW +BVTT 2.6X10 (S)
385	*X-3595-902-1	ARM (HT) ASSY, IDLER
386	X-3595-905-1	ARM ASSY, P ROLLER
387	*X-3595-917-1	ARM ASSY, SHIFT
388	X-3595-906-1	REEL ASSY, TAKE-UP
389	X-3595-907-1	REEL ASSY, SUPPLY
390	X-3595-908-1	BASE ASST (B), REEL
391	X-3595-919-1	ARM ASSY, CLUTCH
392	*X-3595-904-1	CAM (B) ASSY, LOCK
393	*3-595-910-01	CAM (A), LOCK
394	X-3595-920-1	FLYWHEEL ASSY (S)
395	X-3595-911-1	HOUSING ASSY
396	3-701-440-01	WASHER
397	

ELECTRICAL PARTS

HP101	1-543-363-11	HEAD (PB)
M301	X-3595-923-1	MOTOR, ASSY (W/PULLEY)
S712	1-570-302-11	SWITCH, LEAF (B)(FF/REW)
S713	1-570-305-11	SWITCH, LEAF (E)(Cr02)
S714	1-570-304-11	SWITCH, LEAF (D)(PLAY)

(4) **DECK A** : TCM-54FMF

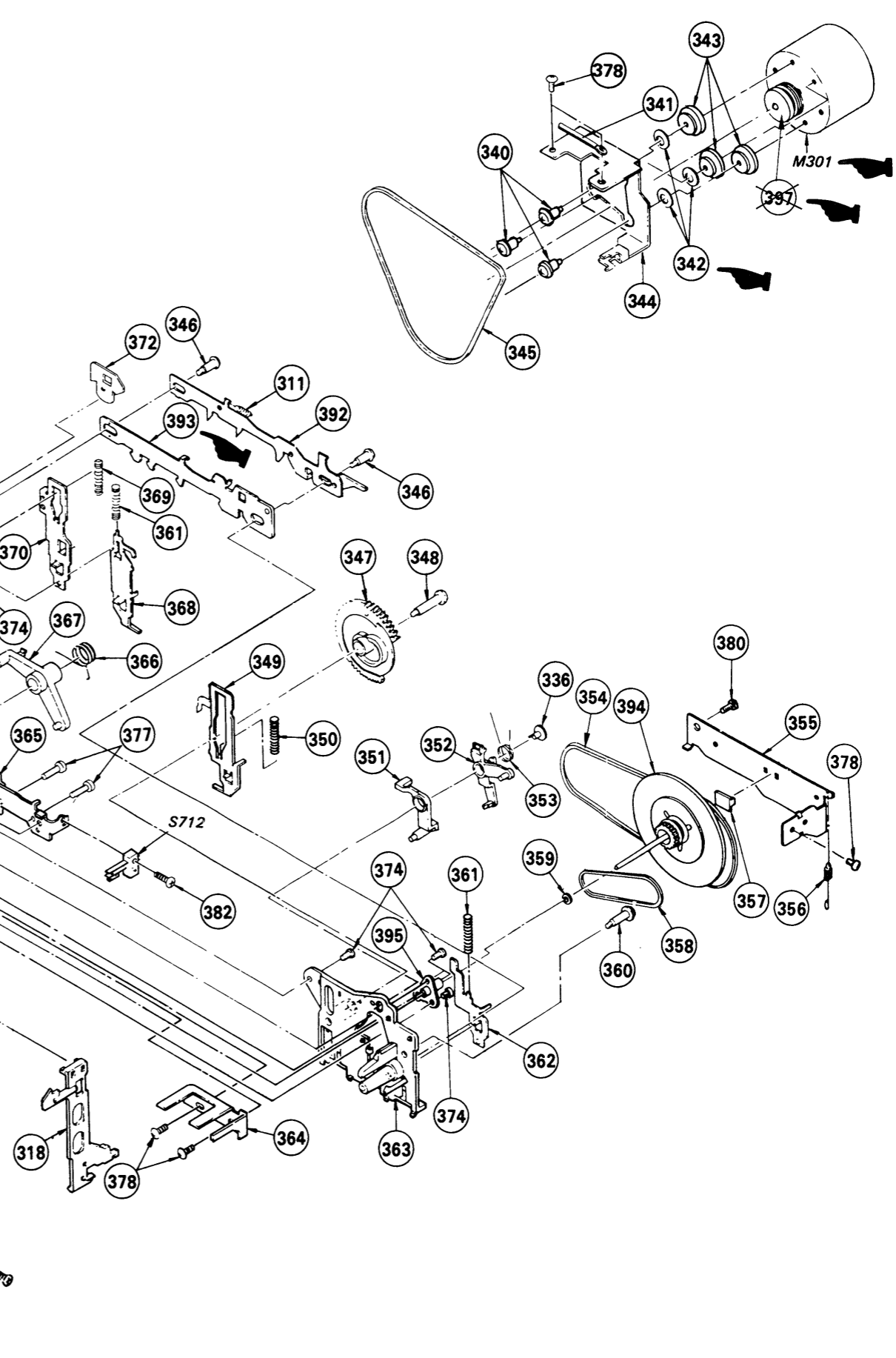
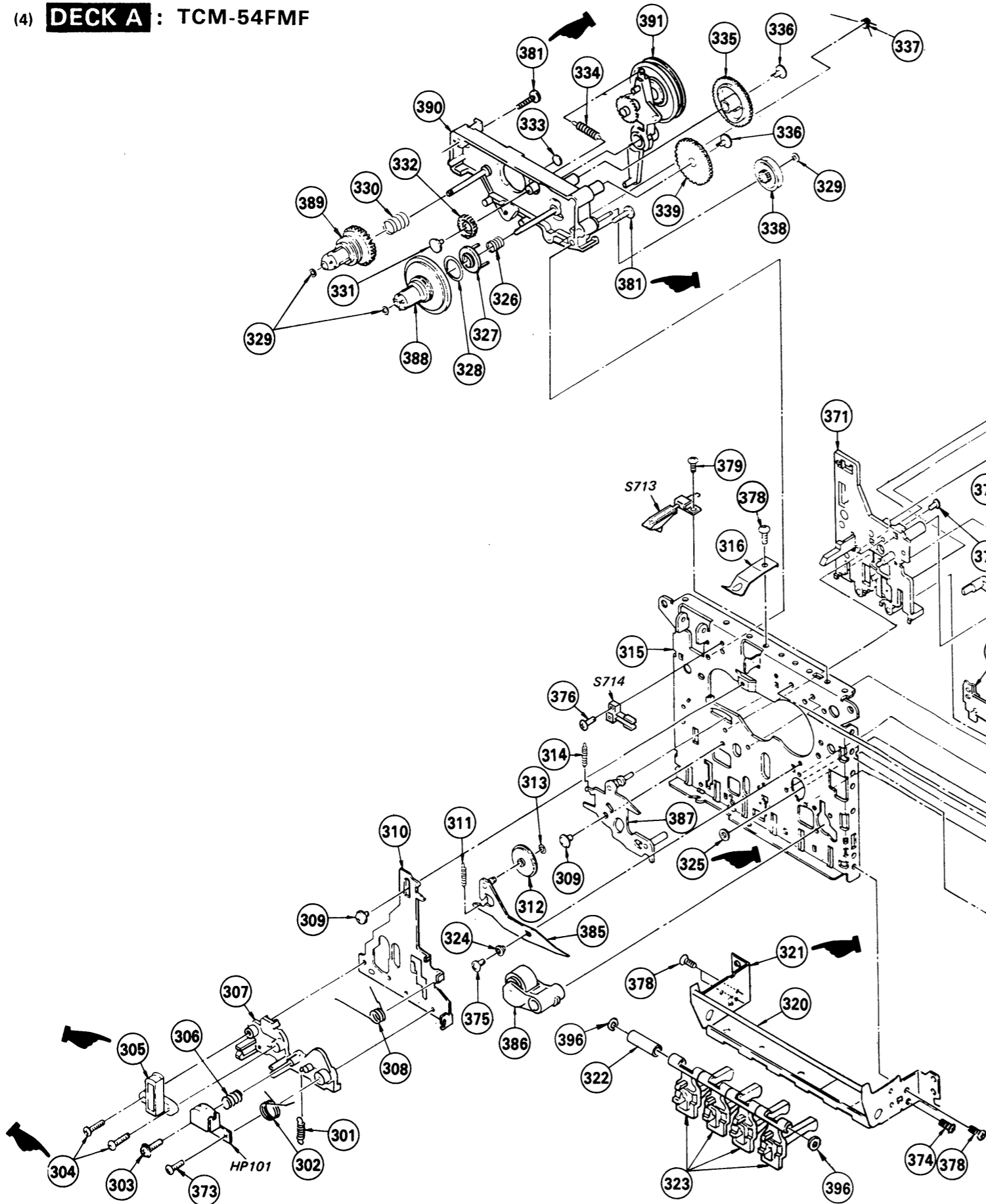

TCM-53FMF (DECK B)

No.	Part No.	Description
401	3-595-956-01	SPRING
402	3-595-955-01	SPRING
403	3-595-972-01	SCREW (2X9), WASHER HEAD
404	3-595-971-01	SCREW (2X9), BINDING
405	3-595-954-01	SPRING
406	*3-595-926-01	BASE, HEAD
407	3-595-953-01	SPRING
408	3-595-964-01	SCREW (A)
409	*3-595-912-01	CHASSIS, HEAD
410	3-595-951-01	SPRING
411	3-595-941-01	IDLER, PLAY
412	3-595-946-01	SPRING (C)
413	3-595-969-01	WASHER, POLYSLIDER
414	3-595-919-01	COLLAR
415	*3-595-902-01	ARM, PAUSE
416	3-595-970-01	WASHER, OIL STOP
417	*3-595-901-01	CHASSIS
419	3-595-932-01	LEVER (F), EJECT
420	*3-596-020-01	HOLDER (B), BUTTON
421	*3-595-920-01	SHAFT, BUTTON
422	3-595-933-01	LEVER, BUTTON
423	*3-596-023-01	BRACKET, REC SWITCH
424	*3-595-994-01	ARM, REC
425	7-685-868-01	SCREW (2.6X20), DIA
426	*3-596-004-01	CLAMP, CORD
427	3-595-925-01	SENSOR, REC
428	3-595-916-01	SPRING
429	3-595-961-01	SPRING
430	3-595-938-01	CLUTCH, AUTO
431	3-595-968-01	FELT, AUTO CLUTCH
432	3-558-708-01	WASHER, STOPPER
433	3-595-928-01	BUSHING
434	3-595-957-01	SPRING
435	3-595-927-01	GEAR, FF
436	3-596-013-01	WASHER (5.6X0.19), LUMILER
437	3-595-963-01	SPRING
438	3-595-937-01	GEAR, AUTO CAM
439	3-595-928-01	BUSHING
440	3-595-960-01	SPRING
441	3-595-935-01	PULLEY, AUTO
442	3-595-936-01	GEAR, AUTO
443	3-596-011-01	WASHER (B)
444	3-595-945-01	CUSHION, MOTOR
445	*3-596-024-01	HOLDER, MOTOR
446	3-515-973-01	SCREW, MOTOR
447	3-596-010-01	BELT, FR
448	3-595-965-01	SCREW (B)
449	*3-595-918-01	ARM, INTERLOCK
450	*3-595-992-01	LEVER (C), REC
451	3-595-923-01	HOLDER (B), LEVER
452	*3-595-909-01	LEVER (B), PLAY
453	3-595-949-01	SPRING
454	3-595-948-01	SPRING
455	*3-595-905-01	LEVER (H), REW
456	3-595-983-01	SPRING
457	*3-595-908-01	LEVER (BH), REC

TCM-53FMF (DECK B)

No.	Part No.	Description
458	3-595-950-01	SPRING (B)
459	*3-595-906-01	BRACKET, SOLENOID
460	3-595-930-01	ARM (H), LOCK
461	*3-595-904-01	LEVER (H), FF
462	3-595-929-01	GEAR (C)
463	3-595-967-01	SCREW (D)
464	3-595-962-01	SPRING
465	3-595-940-01	ARM, AUTO LOCK
466	3-595-939-01	ARM (B), AUTO
467	3-595-947-01	SPRING
468	3-595-942-01	BELT, DRIVE
469	*3-595-993-01	BRACKET, FLYWHEEL
470	3-595-931-01	SPACER, CAPSTAN
471	3-595-944-01	BELT, AUTO
472	3-595-966-01	SCREW (C)
473	3-595-952-01	SPRING
474	3-701-437-21	WASHER, POLY-SLIDER
475	3-595-924-01	CAM, PAUSE
476	*3-595-991-01	LEVER, STOP
477	3-595-922-01	HOLDER (A), LEVER
478	7-621-772-40	SCREW +B 2X8
479	7-624-104-04	STOP RING 2.0, TYPE -E
480	7-685-781-01	SCREW +PTT 2X4 (S)
481	7-685-782-01	SCREW +PTT 2X5 (S)
482	7-685-783-01	SCREW +PTT 2X6 (S)
483	7-685-786-01	SCREW +PTT 2X12 (S)
484	7-685-790-01	SCREW +PTT 2.6X4 (S)
485	7-685-791-01	SCREW +PTT 2.6X5 (S)
486	7-685-792-01	SCREW +PTT 2.6X6 (S)
487	7-685-863-01	SCREW +BVTT 2.6X8 (S)
488	7-685-864-01	SCREW +BVTT 2.6X10 (S)
489	3-595-959-01	SPRING
490	7-688-002-11	W 2.6, MIDDLE
492	X-3595-905-1	ARM ASSY, P ROLLER
493	*X-3595-902-1	ARM (HT) ASSY, IDLER
494	*X-3595-917-1	ARM ASSY, SHIFT
495	X-3595-906-1	REEL ASSY, TAKE-UP
496	X-3595-907-1	REEL ASSY, SUPPLY
497	X-3595-908-1	BASE ASST (B), REEL
498	X-3595-919-1	ARM ASSY, CLUTCH
499	*X-3595-904-1	CAM (B) ASSY, LOCK
500	*3-595-910-01	CAM (A), LOCK
501	X-3595-920-1	FLYWHEEL ASSY (S)
502	X-3595-911-1	HOUSING ASSY
503	*X-3595-903-1	LEVER (B) ASSY, PAUSE
504	7-685-854-01	SCREW, +BVTT 2x8
505	
506	3-701-441-01	WASHER

ELECTRICAL PARTS

HE101	1-543-261-11	HEAD, ERASE (886-01-24)
HRP101	1-543-363-11	HEAD, REC/PB
M302	X-3595-923-1	MOTOR ASSY (W/PULLEY)
S715	1-570-303-11	SWITCH, LEAF (C)(MOTOR)
S716	1-570-302-11	SWITCH, LEAF (B)(FF/REW)
S717	1-570-713-11	SWITCH, LEAF (A)(REC)
S718	1-570-304-11	SWITCH, LEAF (D)(PLAY)

(5) DECK B : TCM-53FMF

