

# TC-W285/W380

## SERVICE MANUAL

US Model

TC-W285

TC-W380

Canadian Model

E Model

Italian Model

TC-W285



Photo: TC-W380

- TC-W285 is the stereo double cassette deck section in SEN-280.

### SPECIFICATIONS

#### Recording system

4-track 2-channel stereo

#### Fast-forward and rewind time

Approx. 120 sec. (with C-60 cassette)

#### Bias

AC Bias

#### Signal-to-noise ratio (NAB, at peak level)

Cassette	Dolby NR switch	
	OFF	B-TYPE ON
TYPE IV (Sony METAL-ES)	58 dB	65 dB
TYPE II (Sony UX-S)	56 dB	63 dB
TYPE I (Sony HF-S)	54 dB	61 dB

#### Total harmonic distortion

1.0 % (with Sony METAL-ES cassette)

#### Frequency response (DOLBY NR OFF)

TYPE IV cassette (Sony METAL-ES)	30-15,000 Hz ( $\pm 3$ dB) 30-13,000 Hz (OVU recording)
TYPE II cassette (Sony UX-S)	30-14,000 Hz ( $\pm 3$ dB)
TYPE I cassette (Sony HF-S)	30-13,000 Hz ( $\pm 3$ dB)

#### Wow and flutter 0.12% WRMS (NAB)

#### Inputs

Connector	Type	Sensitivity	Impedance
LINE IN	phono	77.5 mV (-20 dB)	50 kilohms

#### Outputs

Connector	Type	Rated output level	Load impedance
LINE OUT	phono	0.44 V (-5 dB) at load impedance 47 kilohms	over 10 kilohms

Model Name Using Similar Mechanism	TC-W200	
Tape Transport Mechanism Type	DECK A	TCM-YM47CW-45
	DECK B	TCM-YM47CW-46

#### General

##### Power requirements (TC-W380)

120 V AC, 60 Hz

##### Power consumption (TC-W380)

12 W

##### Dimensions

TC-W380:

Approx. 430 x 117.5 x 250 mm (w/h/d)  
(17 x 4 $\frac{5}{8}$  x 9 $\frac{7}{8}$  inches)

including projecting parts and controls

TC-W285:

Approx. 430 x 117.5 x 250 mm (w/h/d)  
(17 x 4 $\frac{5}{8}$  x 9 $\frac{7}{8}$  inches)

including projecting parts and controls

##### Weight

TC-W380:

Approx. 3.2 kg (7 lb 2 oz) net

TC-W285:

Approx. 2.85 kg (6 lb 6 oz) net

##### Supplied accessories (TC-W380)

Connecting cord (2)

System control cord (3-pin) (1)

Dolby noise reduction manufactured under license from Dolby Laboratories Licensing Corporation.

"DOLBY" and the double-D symbol  $\square\square$  are trademarks of Dolby Laboratories Licensing Corporation.

STEREO CASSETTE DECK  
**SONY**<sup>®</sup>



TABLE OF CONTENTS

<u>Section</u>	<u>Title</u>	<u>Page</u>
Specifications	.....	1
Safety Check-out	.....	2
<b>SECTION 1. ADJUSTMENTS</b>	.....	3
<b>SECTION 2. DIAGRAMS</b>		
2-1. Semiconductor Lead Layouts	.....	5
2-2. Printed Wiring Boards	.....	6
2-3. Schematic Diagram	.....	9
<b>SECTION 3. EXPLODED VIEWS</b>	.....	11
<b>SECTION 4. ELECTRICAL PARTS LIST</b>	.....	16



SERVICING NOTE FOR TC-W285

[To supply B+ voltage]

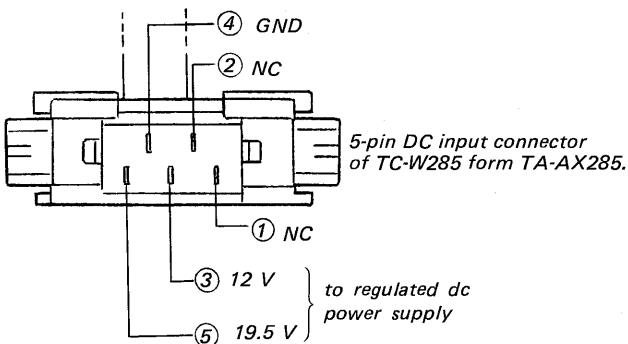
When this model alone operates, connect the unit to the regulated DC power supply, since power of this model is fed from TA-AX285.



SAFETY-RELATED COMPONENT WARNING!!

COMPONENTS IDENTIFIED BY MARK  OR DOTTED LINE WITH MARK  ON THE SCHEMATIC DIAGRAMS AND IN THE PARTS LIST ARE CRITICAL TO SAFE OPERATION. REPLACE THESE COMPONENTS WITH SONY PARTS WHOSE PART NUMBERS APPEAR AS SHOWN IN THIS MANUAL OR IN SUPPLEMENTS PUBLISHED BY SONY.

ATTENTION AU COMPOSANT AYANT RAPPORT À LA SÉCURITÉ!

LES COMPOSANTS IDENTIFIÉS PAR UNE MARQUE  SUR LES DIAGRAMMES SCHÉMATIQUES ET LA LISTE DES PIÈCES SONT CRITIQUES POUR LA SÉCURITÉ DE FONCTIONNEMENT. NE REMPLACER CES COMPOSANTS QUE PAR DES PIÈCES SONY DONT LES NUMÉROS SONT DONNÉS DANS CE MANUEL OU DANS LES SUPPLÉMENTS PUBLIÉS PAR SONY.

SAFETY CHECK-OUT

After correcting the original service problem, perform the following safety check before releasing the set to the customer:

Check the antenna terminals, metal trim, "metallized" knobs, screws, and all other exposed metal parts for AC leakage. Check leakage as described below.

LEAKAGE TEST

The AC leakage from any exposed metal part to earth ground and from all exposed metal parts to any exposed metal part having a return to chassis, must not exceed 0.5 mA (500 microamperes). Leakage current can be measured by any one of three methods.

1. A commercial leakage tester, such as the Simpson 229 or RCA WT-540A. Follow the manufacturers' instructions to use these instruments.
2. A battery-operated AC milliammeter. The Data Precision 245 digital multimeter is suitable for this job.
3. Measuring the voltage drop across a resistor by means of a VOM or battery-operated AC voltmeter. The "limit" indication is 0.75 V, so analog meters must have an accurate low-voltage scale. The Simpson 250 and Sanwa SH-63Trd are examples of a passive VOM that is suitable. Nearly all battery operated digital multimeters that have a 2 V AC range are suitable. (See Fig. A)

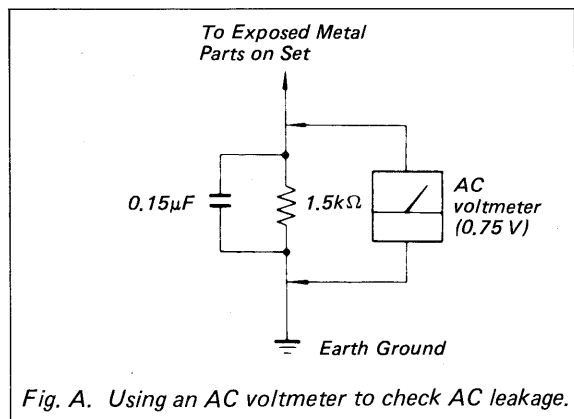

Fig. A. Using an AC voltmeter to check AC leakage.

**SECTION 1  
ADJUSTMENTS**

**1-1. MECHANICAL ADJUSTMENTS**

**PRECAUTION**

- Clean the following parts with a denatured-alcohol-moistened swab:
 

record/playback head	pinch roller
erase head	rubber belts
capstan	idlers

**Torque Measurement (DECKS A and B)**

Torque	Torquement	Meter reading
FWD	CQ-102C	30 - 70 g·cm (0.42 - 0.97 oz·inch)
FWD Back tension	CQ-102C	1.5 - 5.5 g·cm (0.020 - 0.076 oz·inch)
FF, REW	CQ-201B	63 g·cm or more (0.87 oz·inch)

**1-2. ELECTRICAL ADJUSTMENTS**

- Demagnetize the record/playback and erase head with a head demagnetizer.
- Do not use a magnetized screwdriver for the adjustments.
- After the adjustments, apply suitable locking compound to the parts adjusted.
- The adjustments should be performed with the rated power supply voltage unless otherwise noted.
- The adjustments should be performed in the order given in this service manual. (As a general rule, playback circuit adjustment should be completed before performing recording circuit adjustment.)
- The adjustments should be performed for both L-CH and R-CH.
  - Switches and controls should be set as follows unless otherwise specified.
    - DOLBY NR switch: OFF
    - TAPE TYPE switch: TYPE I (NORMAL)

**Record Mode -**

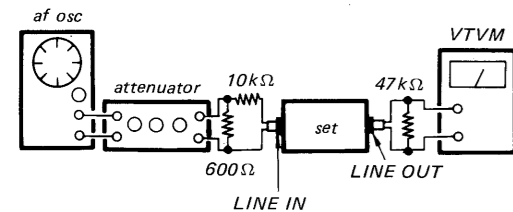

Note: Before recording short CN505 with a lead wire, otherwise MUTING functions and output signal does not appear at LINE OUT terminals.

**Standard Input Level**

	LINE IN
source impedance	10 kΩ
input level	0.25 V (-10 dB)

**Standard Output Level**

	LINE OUT
load impedance	47 kΩ
output level	0.44 V (-5 dB)

**Record/Playback Head Azimuth Adjustment** DECK A  
DECK B

**Procedure:**

- Mode: FWD playback

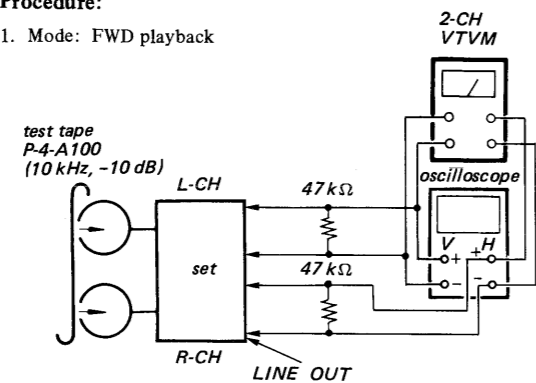

- Turn the adjustment screw and check output peaks. If the peaks do not match for L-CH and R-CH, turn the adjustment screw so that outputs match within 1 dB of peak.

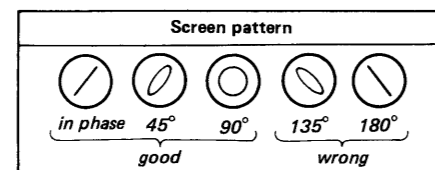
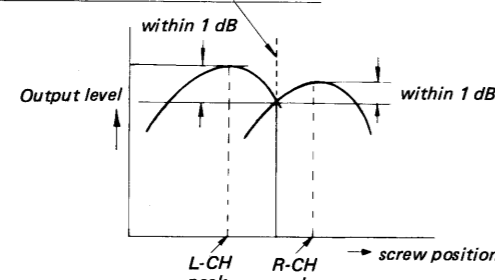

- After the adjustment, apply suitable locking compound to the adjustment screw.

**Adjustment Location:**

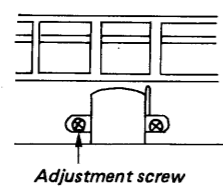

**Test Tape:**

Type	Signal	Used for
P-4-A100	10kHz, -10dB	Azimuth Adjustment
P-4-L300	315Hz, 0dB	Level Adjustment
WS-48A	3kHz, 0dB	Tape Speed Adjustment

**[LINE IN/OUT for TC-W285] : CN321**

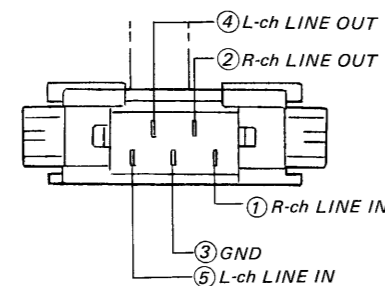

**Tape Speed Adjustment** DECK A  
DECK B

**Procedure:**

- Mode: FWD playback

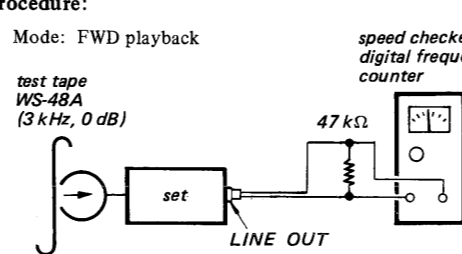

- Short the pins of CN504 with a wire to set the high speed mode.

**Specification:** high speed

Speed checker	Digital frequency counter
±0.5%	5,980 ±30 Hz

Frequency difference between the beginning and the end of the tape should be within 1.5% (90 Hz).

**Adjustment Location:**

- DECK-A: RV501
- DECK-B: RV503

- Remove the wire in step 1. (CN504)

**Specification:** normal speed

Speed checker	Digital frequency counter
±0.3%	2,980 ±10 Hz

Frequency difference between the beginning and the end of the tape should be within 1.5% (45 Hz).

**Adjustment Location:**

- DECK-A: RV502
- DECK-B: RV504

- If the specifications are not satisfied, repeat step 1 and 2.

**Playback Level Adjustment** DECK A  
DECK B

**Procedure:**

- Mode: FWD playback

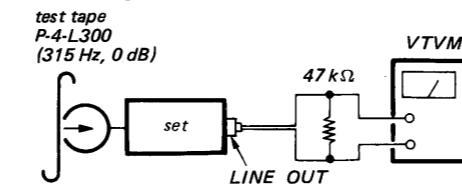

**Adjust,**

- DECK-A: RV101 (L-CH), RV201 (R-CH)
  - DECK-B: RV102 (L-CH), RV202 (R-CH)
- so that the specifications are satisfied.

**Specification:**

LINE OUT level: 0.41 - 0.46 V (-5 ±0.5 dB)  
level difference between the channels: within 0.5 dB

**Record Bias Current Adjustment** DECK B

**Setting:**

REC LEVEL control: standard record (See page 3.)

**Procedure:**

- Mode: record

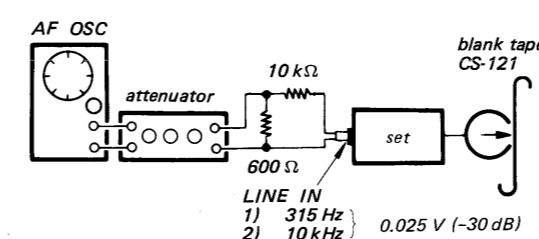

- Mode: playback

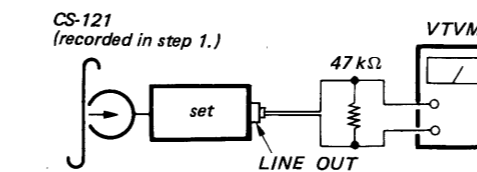

Playback the tape record in step 1. If the specification is not satisfied, adjust CT401-1 (L-CH), CT401-2 (R-CH) and repeat steps 1 and 2.

**Specification:**

The LINE OUT level of 10 kHz signal relative to that of 315 Hz: -0.5 dB to 0.5 dB.

**Adjustment Location:**

[AUDIO BOARD] - COMPONENT SIDE -

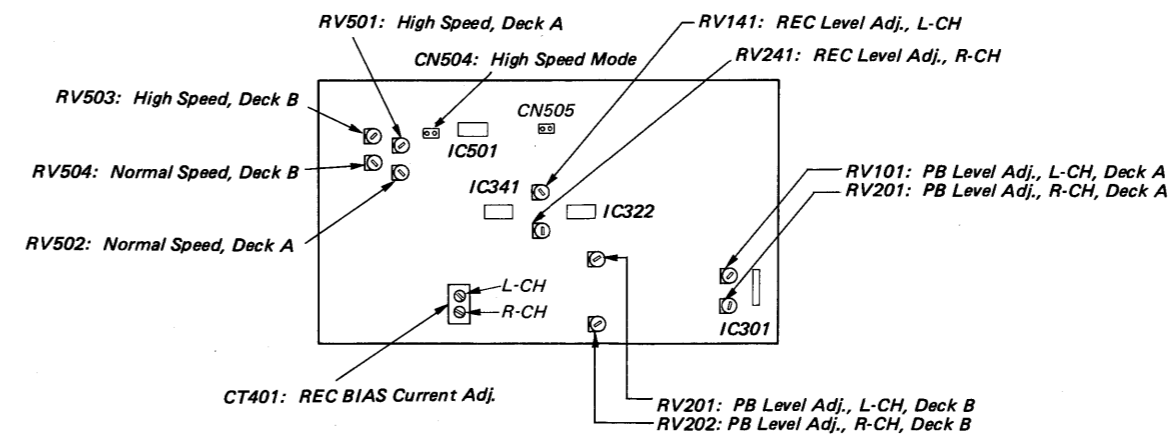

**SECTION 2  
DIAGRAMS**

**2-1. SEMICONDUCTOR LEAD LAYOUTS**

M4001BP  
M4011BP  
M4066BP

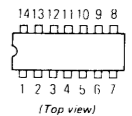

DTA114ES  
DTC114ES  
DTC144ES



CXA1100P  
CXA1198AP  
μPD4051BC

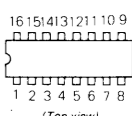

2SD1585-L  
2SD2012



LA3160

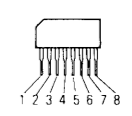

BN1L4M  
2SC2785



IR2E31A

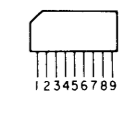

US1060M  
UZL-12L1  
10E2



2SC945  
2SC1815Y  
2SD1387

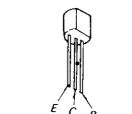

SEL1210S  
SEL1910A



● SEMICONDUCTOR LOCATION

Ref. No.	Location	Ref. No.	Location
D191	I-15	IC303	B-11
D192	I-15	IC322	D-10
D193	I-15	IC341	D-8
D194	I-15	IC342	D-6
D195	J-15	IC501	E-7
D291	I-16	IC502	F-8
D292	I-16		
D293	I-16	Q101	C-11
D294	I-16	Q121	E-13
D295	J-16	Q141	D-8
D401	B-6	Q201	C-11
D402	B-8	Q221	F-12
D501	A-6	Q241	C-8
D504	E-9	Q321	E-9
D505	E-7	Q401	B-6
D506	E-8	Q402	B-6
D507	E-8	Q403	B-6
D509	E-6	Q404	C-6
D510	D-5	Q405	C-7
D511	E-7	Q501	E-6
D512	B-5	Q502	E-5
D514	J-9	Q503	F-5
D515	J-9	Q504	F-6
D601	F-10	Q505	F-5
D602	F-10	Q506	F-5
D603	F-10	Q507	F-6
D604	F-10	Q508	E-7
D605	E-10	Q509	E-8
		Q510	E-6
IC191	I-16	Q511	F-6
IC291	I-17	Q601	E-11
IC301	B-13	Q602	E-10
IC302	B-10		

Note on Schematic Diagram:

- Note:
- All capacitors are in  $\mu\text{F}$  unless otherwise noted. pF:  $\mu\text{F}$  50WV or less are not indicated except for electrolytics and tantalums.
  - All resistors are in  $\Omega$  and  $\frac{1}{4}\text{W}$  or less unless otherwise specified.
  - : adjustment for repair.
  - AC voltage readings in the bias oscillator with a VTVM. no mark: Initial state
  - Voltage and waveforms are dc with respect to ground under no-signal conditions.
  - A ( ) : PB (DECK A)
  - B ( ) : PB (DECK B)
  - < > : REC (DECK B)
  - [ ] : DUBBING (NORMAL)
  - [ [ ] ] : DUBBING (HIGH)
  - Voltages are taken with a VOM (50 k $\Omega$ /V). Voltage variations may be noted due to normal production tolerances.
  - Signal path.
  - ▷ : PB (DECK A)
  - ◁ : REC (DECK B)
  - Switches:

Ref. No.	Switch	Position
S301	TAPE (DECK B)	TYPE I
S302	TAPE (DECK A)	TYPE I
S303	DOLBY NR	OFF
S501	DUBBING SPEED	NORMAL
S601	(W380) ... POWER	OFF
S901	MOTOR, DECK A	OFF
S902	FWD, DECK A	OFF
S903	MOTOR, DECK B	OFF
S904	FWD, DECK B	OFF
S905	RECORD	OFF

Note: The components identified by mark  $\Delta$  or dotted line with mark  $\Delta$  are critical for safety. Replace only with part number specified.

2-2. PRINTED WIRING BOARDS

● See page 5 for semiconductor lead layouts.

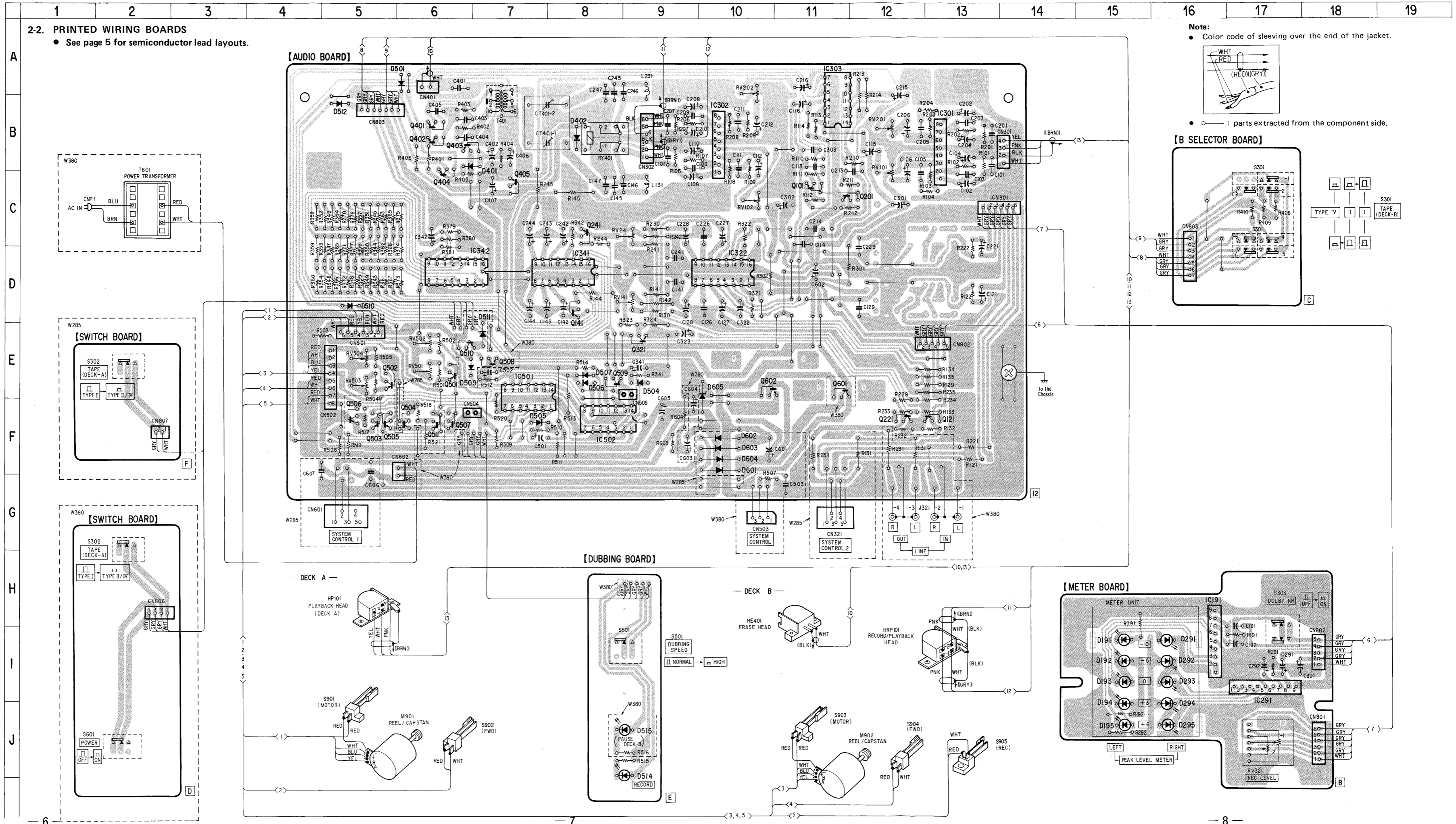

Note:

- Color code of sleeving over the end of the jacket.

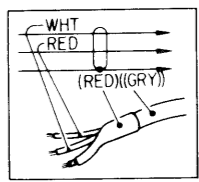

- : parts extracted from the component side.

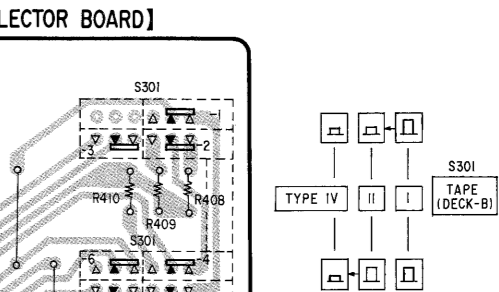



A

B

C

D

E

F

G

H

I

J

• See page 6 for note.

**IC303**

① 5.2, A(5.7)	⑧ 5.2, B(5.8)
② 5.6, A(5.7)	⑨ 5.6
③ 5.6, A(5.7)	⑩ 5.6
④ 5.2, B(5.7)	⑪ 5.2, A(5.8)
⑤ 0, B(10.8)	⑫ 0, A(11.3)
⑥ 0, B(10.8)	⑬ 0, A(11.3)
⑦ GND	⑭ 11.4

**IC502**

① 0, A(11.3)	⑧ 11.4, B(0)
② 8.2, <0>	⑨ 0, A(11.3)
③ 0, <11.2>	⑩ 0, B(10.7)
④ 8.2, <0>	⑪ 0, A/B(11.3)
⑤ 0, <11.2>	⑫ 11.4, A/B(0)
⑥ 0, <11.2>	⑬ 11.4, A/B(0)
⑦ GND	⑭ 11.4(VCC)

**IC501**

① 0, <10.6>	⑧ 0, A(10.0), B(9.4), <0>
② 0, <11.2>	⑨ 0, A(10.7), B(10.2)
③ 11.4, <0>	⑩ 11.4, A/B(0)
④ 11.2, <0>	⑪ 11.4, B(0)
⑤ 0, <11.2>	⑫ 2.0, B(11.3)
⑥ 0, A(11.3)	⑬ 8.2, <0>
⑦ GND	⑭ 11.4(VCC)

**TAPE B TYPE**

	I	II	IV
T401	<37>	<45>	<79>
T401	<14>	<17>	<30>
C408	<8.3>	<10>	<18>
R ch	<7.2>	<8.7>	<15> (AC)

**TAPE B TYPE**

	I	II	IV
Q401	<0.2>	<0.2>	<0.4>
E	<5.0>	<5.9>	<10>
C	<0.3>	<0.2>	<0.4>
Q402	<0.2>	<0.2>	<0.4>
E	<5.0>	<5.9>	<10>
C	<5.0>	<5.9>	<10>
B	<0.2>	<0.2>	<0.4>
Q403	<5.0>	<5.9>	<10>
E	<5.0>	<5.9>	<10>
C	11.4	11.4	11.4
B	<5.6>	<6.6>	<10.7>

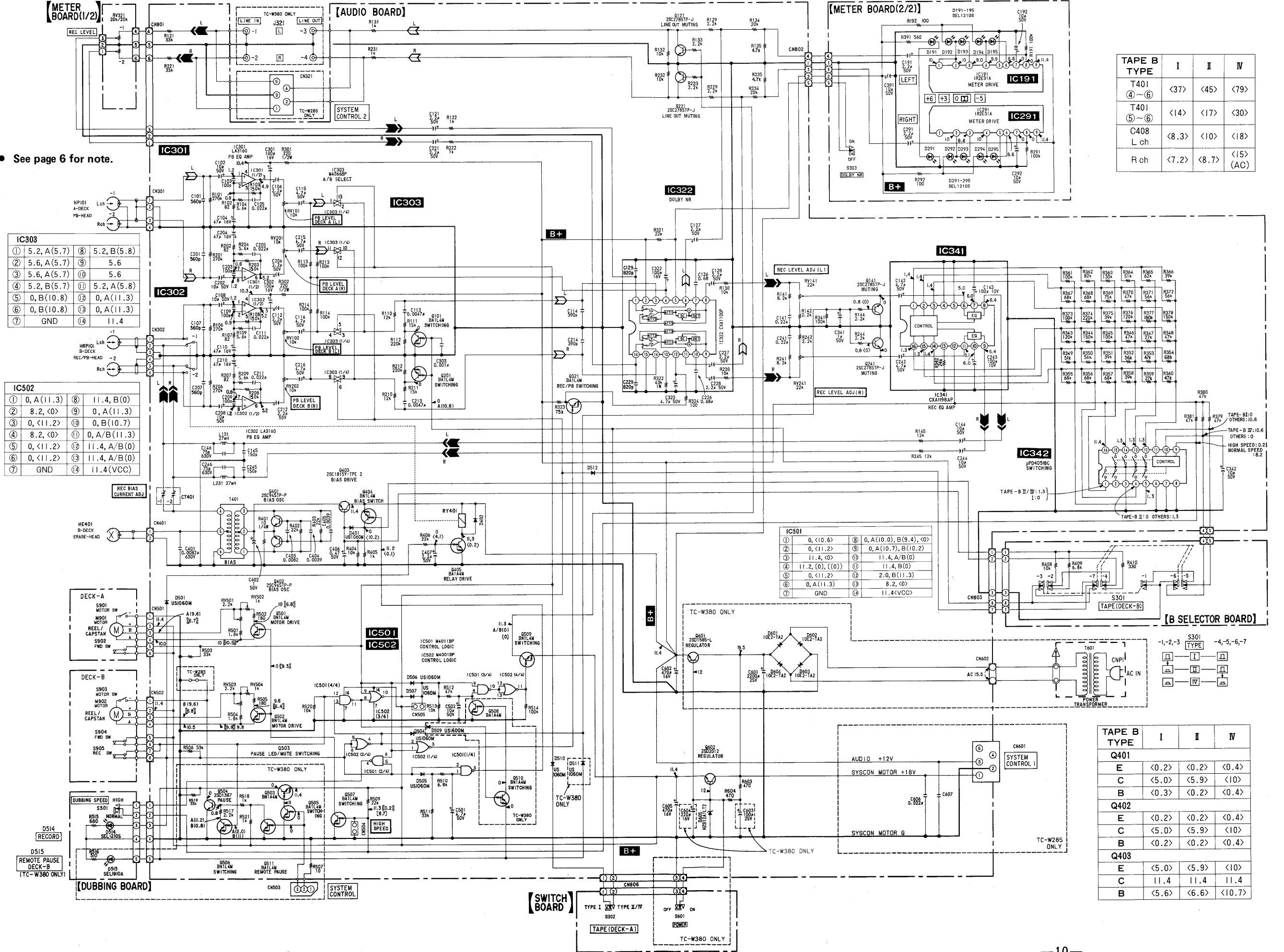



**SECTION 3  
EXPLODED VIEWS**

**NOTE:**

- The mechanical parts with no reference number in the exploded views are not supplied.
- The construction parts of an assembled part are indicated with a collation number in the remark column.
- Items marked "\*" are not stocked since they are seldom required for routine service. Some delay should be anticipated when ordering these items.

- Due to standardization, parts with part number suffix -XX and -X may be different from the parts specified in the components used on the set.
- Color Indication of Appearance Parts  
Example:  
(RED) ... KNOB, BALANCE (WHITE)  
↑ Cabinet's Color      ↑ Parts' Color

The components identified by mark  or dotted line with mark  are critical for safety. Replace only with part number specified.

Les composants identifiés par une marque  sont critiques pour la sécurité. Ne les remplacer que par une pièce portant le numéro spécifié.

(1) GENERAL

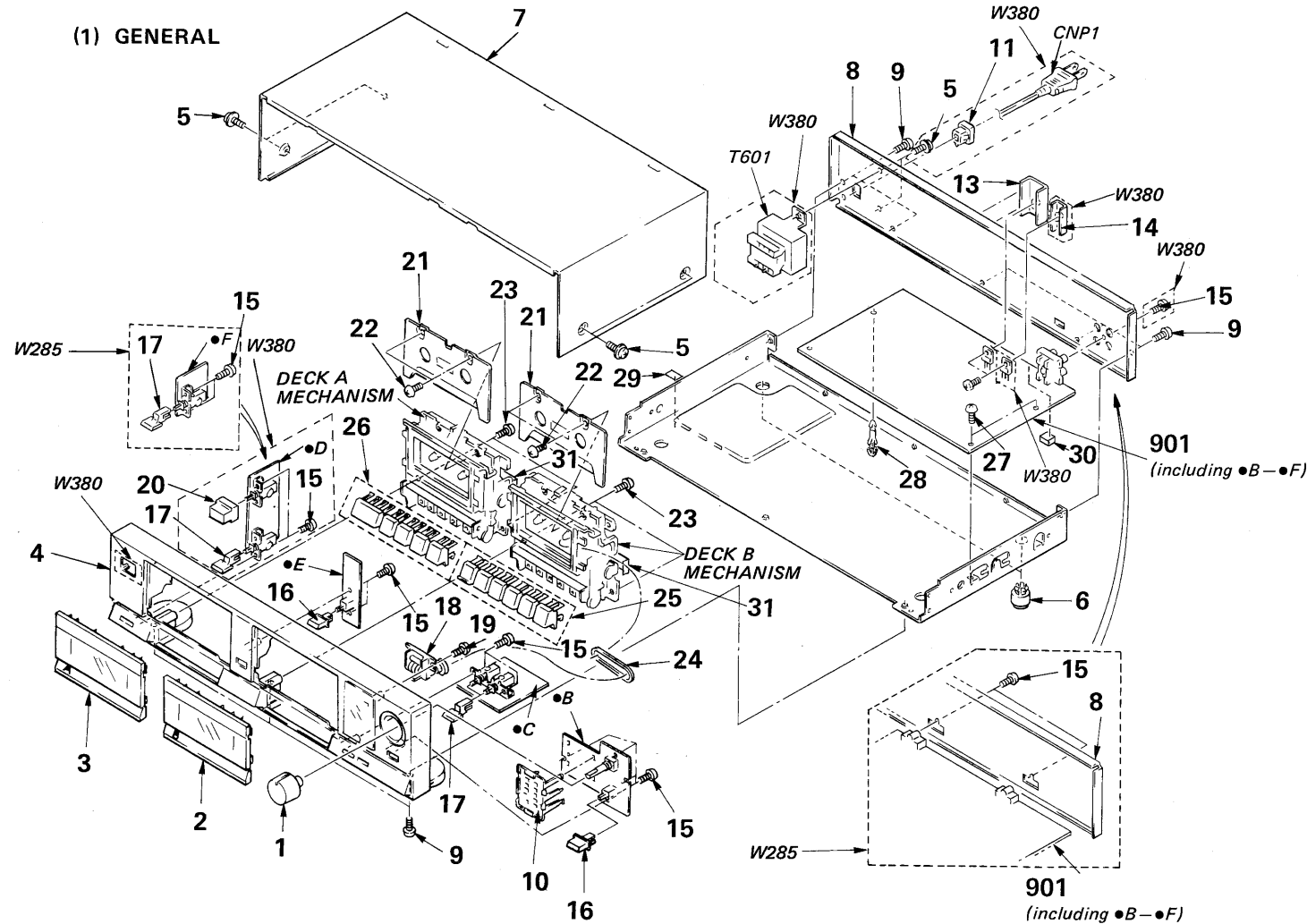

No.	Part No.	Description	Remarks	No.	Part No.	Description	Remarks
1	3-340-117-01	KNOB (REC LEVEL)		15	7-685-646-79	SCREW +BVTP 3X8 TYPE2 N-S	
2	3-340-121-11	LID, CASSETTE (DECK B)		16	4-924-901-01	BUTTON (M) (DOLBY, DUBBING SPEED)	
3	3-340-121-01	LID, CASSETTE (DECK A)		17	3-340-119-01	BUTTON (TAPE)	
4	X-3332-495-1 (W285) ... PANEL ASSY, FRONT X-3332-496-1 (W380) ... PANEL ASSY, FRONT			18	1-548-596-51	COUNTER, TAPE (MIDDLE TYPE)	
5	3-704-366-01	SCREW (CASE) (M3X8)		19	7-685-534-19	SCREW +BTP 2.6X8 TYPE2 N-S	
6	X-4864-303-1	FOOT ASSY		20	4-917-460-01	(W380) ... KNOB, POWER	
7	*3-327-853-01	CASE		21	4-914-974-11	PLATE, ORNAMENTAL, CASSETTE	
8	3-340-122-01 (W380) ... PANEL, BACK 3-340-122-11 (W285) ... PANEL, BACK			22	7-685-133-19	SCREW +P 2.6X6 TYPE2 NON-SLIT	
9	7-682-548-04	SCREW +BVTT 3X8 (S)		23	7-685-647-29	BVTP 3X10 BZn	
10	*3-340-120-01	HOLDER, LED		24	3-513-059-XX	BELT, COUNTER	
11	3-703-571-11	(W380) ... BUSHING (S) (4516), CORD		25	3-327-850-01	BUTTON BLOCK (B)	
13	*4-880-403-11	HEAT SINK		26	3-340-107-01	BUTTON BLOCK (A)	
14	*3-309-144-21	(W380) ... HEAT SINK		27	4-886-821-11	SCREW, S TIGHT, +PTTWH 3X6	
				28	3-346-265-11	SUPPORT, PC	
				29	3-346-375-01	SPACER	
				30	3-893-049-01	(W380) ... CUSHION	
				31	3-346-376-01	(W380) ... MD BRACKET	
				901	*A-2056-399-A (W380) ... MOUNTED PCB, AUDIO *A-2056-400-A (W285) ... MOUNTED PCB, AUDIO		
				CNP1	△.1-558-945-11	CORD, POWER	
				T601	△.1-449-256-11	(W380) ... TRANSFORMER, POWER	

(2) DECK A (1)  
(TCM-YM47CW45)

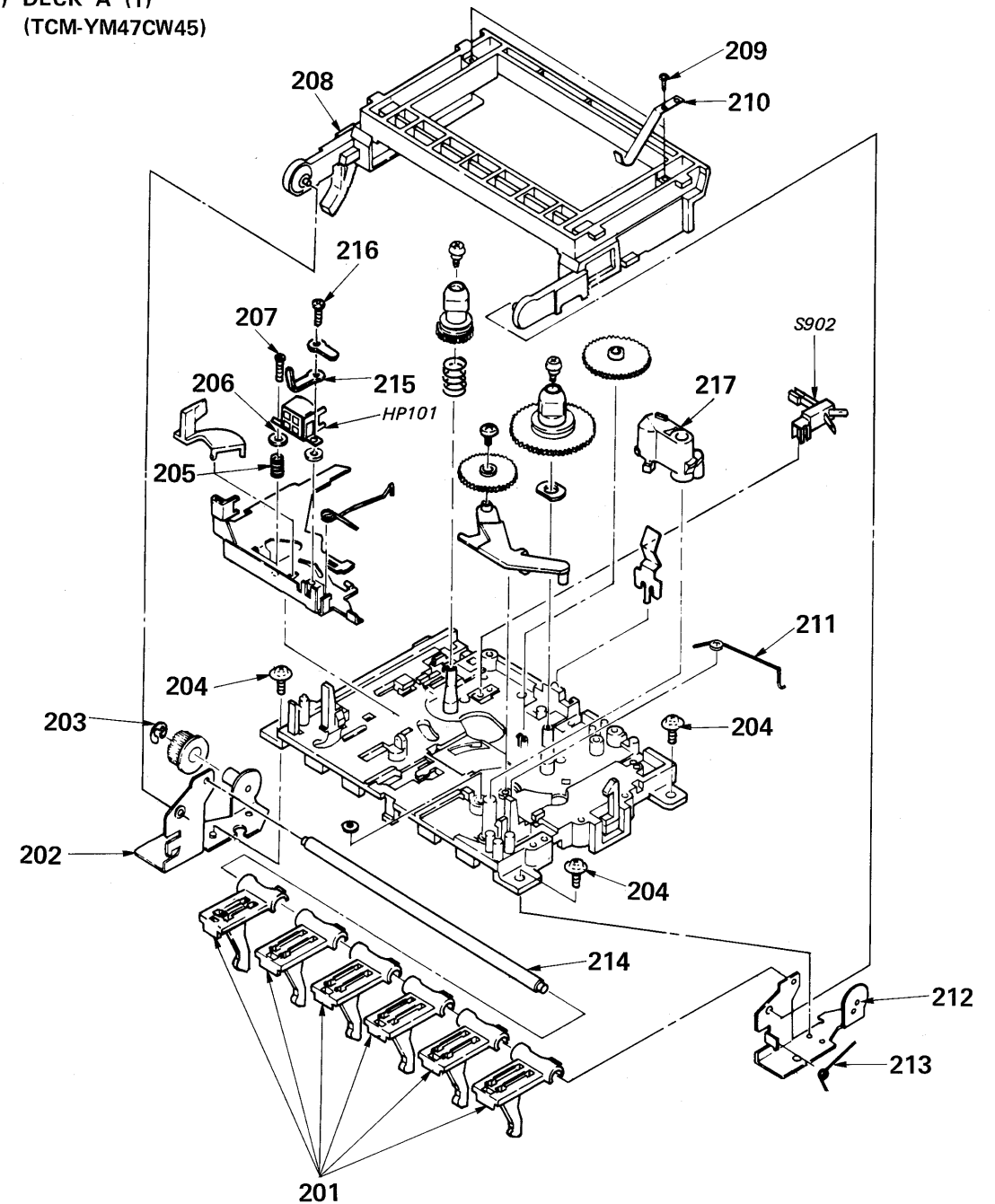

No.	Part No.	Description	Remarks	No.	Part No.	Description	Remarks
201	4-894-971-01	BUTTON LEVER		211	4-894-967-01	SPRING	
202	*4-894-972-01	BUTTON BRACKET R		212	*4-895-017-01	BUTTON BRACKET L ASSY	
203	7-624-106-04	STOP RING 3.0, TYPE -E		213	4-894-973-01	SPRING	
204	7-687-501-31	SCREW +P 2X5 TYPE2 NON-SLIT		214	*4-894-970-01	BUTTON SHAFT W	
205	4-894-955-01	C SPRING		215	3-390-817-01	LUG	
206	3-390-823-01	WASHER, F		216	7-621-255-15	SCREW +P 2X3	
207	7-621-255-55	SCREW, TOTSU P 2X8		217	3-390-805-01	ROLLER ASSY, PINCH	
208	3-390-801-01	CASE, CASSETTE		HP101	1-543-424-11	HEAD, MAGNETIC (PB)	
209	7-685-103-19	SCREW +P 2X5 TYPE2 NON-SLIT		S902	1-570-716-11	SWITCH, LEAF (FWD)	
210	4-894-951-01	KEEP PLATE					

(3) DECK A (2)

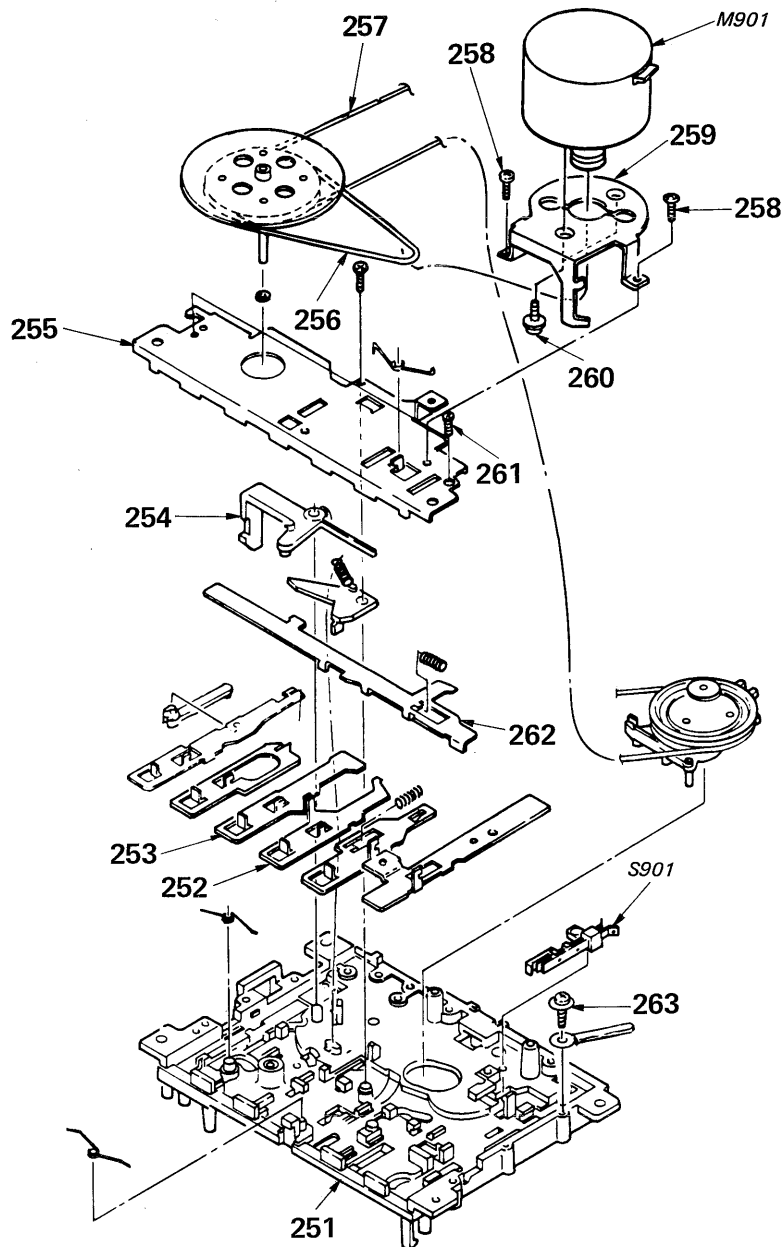

No.	Part No.	Description	Remarks	No.	Part No.	Description	Remarks
251	4-894-968-01	CHASSIS ASSY		259	*3-390-814-01	BRACKET, MOTOR	
252	*4-894-990-01	REW LEVER		260	7-628-253-90	SCREW +PS 2.6X4	
253	*4-894-988-01	FF LEVER W		261	7-685-133-19	SCREW +P 2.6X6 TYPE1	
254	*4-894-980-01	EJECT ARM		262	*4-894-994-01	REC LEVER	
255	*4-894-977-01	BACK PLATE		263	7-687-233-11	SCREW (+ PTPWH) (2.6X6)	
256	3-390-807-01	BELT		M901	X-3390-801-1	MOTOR ASSY	
257	3-390-816-01	BELT, SQUARE		S901	1-570-715-11	SWITCH, LEAF (MOTOR A)	
258	7-621-255-25	SCREW +PTT 2X4 (S)					

(4) DECK B (1)  
(TCM-YM47CW46)

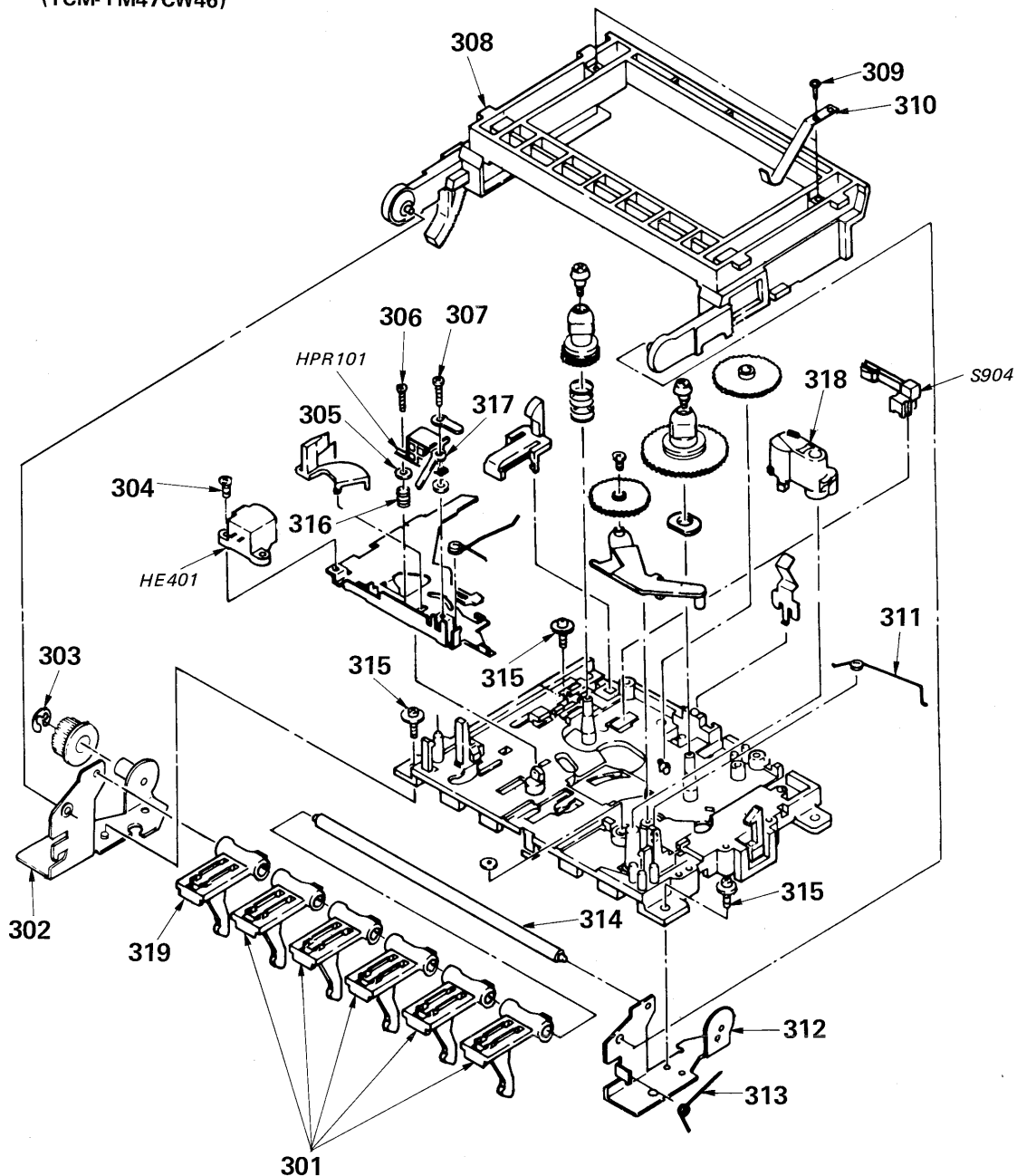

No.	Part No.	Description	Remarks	No.	Part No.	Description	Remarks
301	4-894-971-01	BUTTON LEVER		311	4-894-967-01	SPRING	
302	*4-894-972-01	BUTTON BRACKET R		312	*4-895-017-01	BUTTON BRACKET L ASSY	
303	7-624-106-04	STOP RING 3.0, TYPE -E		313	4-894-973-01	SPRING	
304	7-685-852-01	SCREW +BVTT 2X5 (S)		314	*4-894-970-01	BUTTON SHAFT W	
305	3-390-823-01	WASHER, F		315	7-687-501-31	SCREW, TOTSU PTTWH 2.6X6	
306	7-621-255-55	SCREW, TOTSU P 2X8		316	4-894-955-01	C SPRING	
307	7-621-255-15	SCREW +P 2X3		317	3-390-817-01	LUG	
308	3-390-801-01	CASE, CASSETTE		318	3-390-805-01	ROLLER ASSY, PINCH	
309	7-685-103-19	SCREW +P 2X5 TYPE2 NON-SLIT		319	3-390-824-01	BUTTON LEVER R	
310	4-894-951-01	KEEP PLATE		HE401	1-543-261-11	HEAD, ERASE (886-01-24)	
				HRP101	1-543-424-11	HEAD, MAGNETIC (REC/PB)	
				S904	1-570-716-11	SWITCH, LEAF	



(5) DECK B (2)

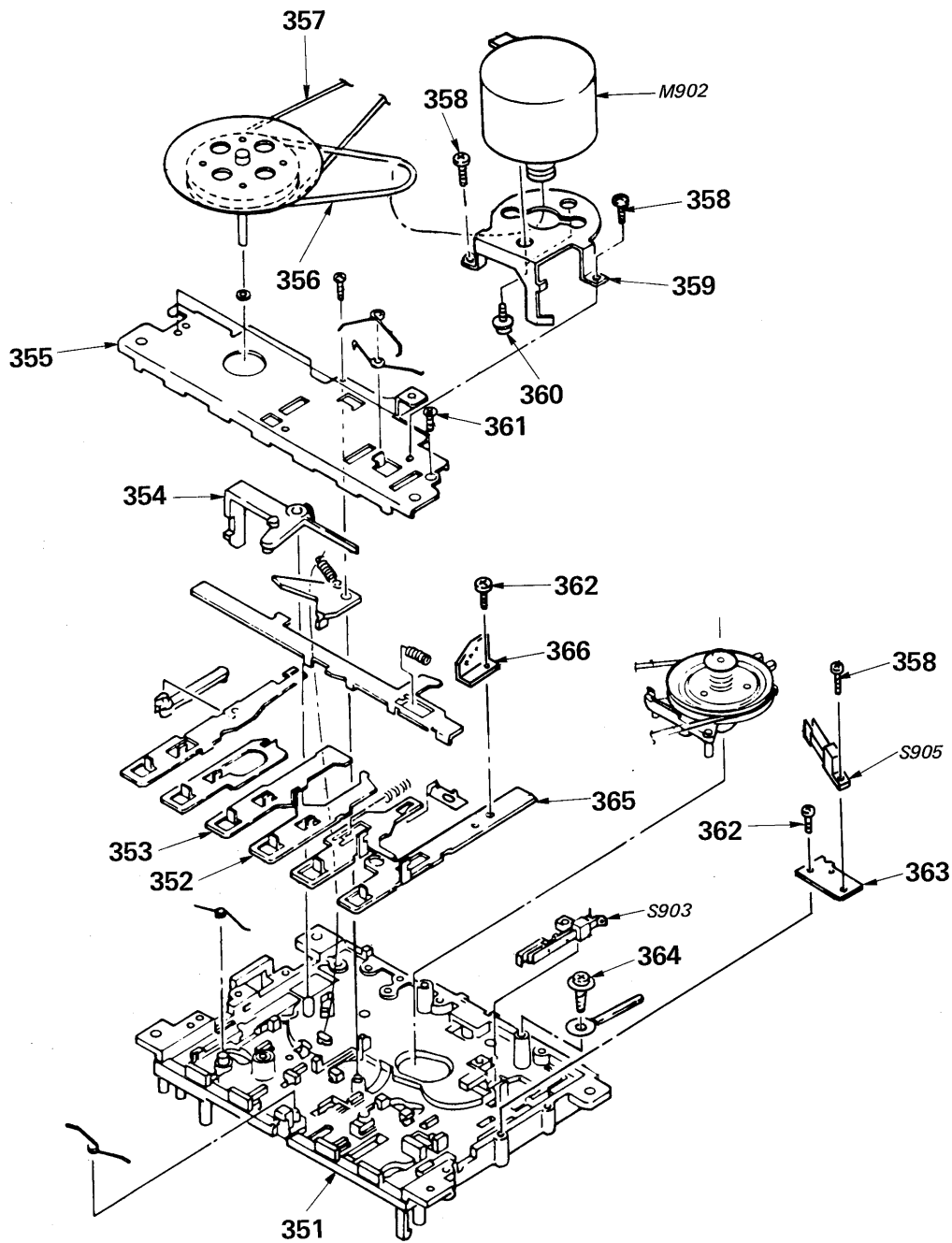

No.	Part No.	Description	Remarks
351	4-894-968-01	CHASSIS ASSY	
352	*4-894-990-01	REW LEVER	
353	*4-894-988-01	FF LEVER W	
354	*4-894-980-01	EJECT ARM	
355	*4-894-977-01	BACK PLATE	
356	3-390-807-01	BELT	
357	3-390-816-01	BELT, SQUARE	
358	7-621-255-25	SCREW +PTT 2X4 (S)	
359	*3-390-814-01	BRACKET, MOTOR	
360	7-628-253-90	SCREW +PS 2.6X4	

No.	Part No.	Description	Remarks
361	7-685-133-19	SCREW +P 2.6X6 TYPE1	
362	7-621-259-35	SCREW +PTT 2.6X5 (S)	
363	*3-390-829-01	BRACKET, SW	
364	7-687-233-11	SCREW (+ PTPWH) (2.6X6)	
365	*4-894-994-01	REC LEVER	
366	*3-390-828-01	LEVER, RSW	
M902	X-3390-801-1	MOTOR ASSY	
S903	1-570-715-11	SWITCH, LEAF	
S905	1-571-037-11	SWITCH, LEAF (REC SW)	

## SECTION 4 ELECTRICAL PARTS LIST

**NOTE:**

- Due to standardization, replacements in the parts list may be different from the parts specified in the diagrams or the components used on the set.
- Items marked "★" are not stocked since they are seldom required for routine service. Some delay should be anticipated when ordering these items.
- If there are two or more same circuits in a set such as a stereophonic machine, only typical circuit parts may be indicated and capacitors and resistors in other same circuits may be omitted.

**CAPACITORS:**

MF:  $\mu$ F, PF:  $\mu$  $\mu$ F.

**RESISTORS**

- All resistors are in ohms.
- F: nonflammable

**COILS**

- MMH: mH, UH:  $\mu$ H

**SEMICONDUCTORS**

In each case, U:  $\mu$ , for example:

UA...:  $\mu$ A..., UPA...:  $\mu$ PA...,  
UPC...:  $\mu$ PC, UPD...:  $\mu$ PD...

The components identified by mark  $\Delta$  or dotted line with mark  $\Delta$  are critical for safety. Replace only with part number specified.

Les composants identifiés par une marque  $\Delta$  sont critiques pour la sécurité. Ne les remplacer que par une pièce portant le numéro spécifié.



Ref.No.	Part No.	Description				
901	*A-2056-399-A	(W380)...MOUNTED PCB, AUDIO				
	*A-2056-400-A	(W285)...MOUNTED PCB, AUDIO				
C101	1-162-291-11	CERAMIC	560PF	10%	50V	
C102	1-123-875-11	ELECT	10MF	20%	50V	
C103	1-162-282-31	CERAMIC	100PF	10%	50V	
C104	1-124-477-11	ELECT	47MF	20%	16V	
C105	1-136-157-00	FILM	0.022MF	5%	50V	
C106	1-124-925-11	ELECT	2.2MF	20%	50V	
C107	1-162-291-11	CERAMIC	560PF	10%	50V	
C108	1-123-875-11	ELECT	10MF	20%	50V	
C109	1-162-282-31	CERAMIC	100PF	10%	50V	
C110	1-124-477-11	ELECT	47MF	20%	16V	
C111	1-136-157-00	FILM	0.022MF	5%	50V	
C112	1-124-925-11	ELECT	2.2MF	20%	50V	
C113	1-161-377-00	CERAMIC	0.0047MF	20%	16V	
C114	1-162-289-31	CERAMIC	390PF	10%	50V	
C115	1-124-927-11	ELECT	4.7MF	20%	50V	
C116	1-124-927-11	ELECT	4.7MF	20%	50V	
C121	1-124-925-11	ELECT	2.2MF	20%	50V	
C126	1-136-175-00	FILM	0.68MF	5%	50V	
C127	1-124-925-11	ELECT	2.2MF	20%	50V	
C128	1-124-925-11	ELECT	2.2MF	20%	50V	
C129	1-162-293-31	CERAMIC	820PF	10%	50V	
C141	1-136-169-00	FILM	0.22MF	5%	50V	
C142	1-124-927-11	ELECT	4.7MF	20%	50V	
C143	1-124-443-00	ELECT	100MF	20%	10V	
C144	1-123-875-11	ELECT	10MF	20%	50V	
C145	1-162-284-31	CERAMIC	150PF	10%	50V	
C146	1-136-273-91	FILM	75PF	5%	630V	
C191	1-124-925-11	ELECT	2.2MF	20%	50V	
C192	1-123-875-11	ELECT	10MF	20%	50V	
C201	1-162-291-11	CERAMIC	560PF	10%	50V	
C202	1-123-875-11	ELECT	10MF	20%	50V	
C203	1-162-282-31	CERAMIC	100PF	10%	50V	
C204	1-124-477-11	ELECT	47MF	20%	16V	
C205	1-136-157-00	FILM	0.022MF	5%	50V	
C206	1-124-925-11	ELECT	2.2MF	20%	50V	
C207	1-162-291-11	CERAMIC	560PF	10%	50V	
C208	1-123-875-11	ELECT	10MF	20%	50V	
C209	1-162-282-31	CERAMIC	100PF	10%	50V	
C210	1-124-477-11	ELECT	47MF	20%	16V	
C211	1-136-157-00	FILM	0.022MF	5%	50V	
C212	1-124-925-11	ELECT	2.2MF	20%	50V	
C213	1-161-377-00	CERAMIC	0.0047MF	20%	16V	

Ref.No.	Part No.	Description				
C214	1-162-289-31	CERAMIC	390PF	10%	50V	
C215	1-124-927-11	ELECT	4.7MF	20%	50V	
C216	1-124-927-11	ELECT	4.7MF	20%	50V	
C221	1-124-925-11	ELECT	2.2MF	20%	50V	
C226	1-136-175-00	FILM	0.68MF	5%	50V	
C227	1-124-925-11	ELECT	2.2MF	20%	50V	
C228	1-124-925-11	ELECT	2.2MF	20%	50V	
C229	1-162-293-31	CERAMIC	820PF	10%	50V	
C241	1-136-169-00	FILM	0.22MF	5%	50V	
C242	1-124-927-11	ELECT	4.7MF	20%	50V	
C243	1-124-443-00	ELECT	100MF	20%	10V	
C244	1-123-875-11	ELECT	10MF	20%	50V	
C245	1-162-284-31	CERAMIC	150PF	10%	50V	
C246	1-136-273-91	FILM	75PF	5%	630V	
C291	1-124-925-11	ELECT	2.2MF	20%	50V	
C292	1-123-875-11	ELECT	10MF	20%	50V	
C301	1-126-101-11	ELECT	100MF	20%	16V	
C302	1-126-101-11	ELECT	100MF	20%	16V	
C303	1-162-294-31	CERAMIC	0.001MF	10%	50V	
C322	1-126-101-11	ELECT	100MF	20%	16V	
C323	1-124-927-11	ELECT	4.7MF	20%	50V	
C341	1-124-499-11	ELECT	1MF	20%	50V	
C342	1-123-875-11	ELECT	10MF	20%	50V	
C391	1-123-875-11	ELECT	10MF	20%	50V	
C401	1-136-562-11	FILM	0.0082MF	5%	630V	
C402	1-124-499-11	ELECT	1MF	20%	50V	
C403	1-130-482-00	MYLAR	0.0082MF	5%	50V	
C404	1-130-478-00	MYLAR	0.0039MF	5%	50V	
C405	1-130-478-00	MYLAR	0.0039MF	5%	50V	
C406	1-124-902-00	ELECT	0.47MF	20%	50V	
C407	1-124-925-11	ELECT	2.2MF	20%	50V	
C501	1-124-927-11	ELECT	4.7MF	20%	50V	
C502	1-123-875-11	ELECT	10MF	20%	50V	
C601	1-124-563-11	(W380)...ELECT	2200MF	20%	25V	
C602	1-126-103-11	ELECT	470MF	20%	16V	
C603	1-124-478-11	(W380)...ELECT	100MF	20%	25V	
C604	1-124-120-11	(W380)...ELECT	220MF	20%	16V	
C605	1-126-103-11	ELECT	470MF	20%	16V	
C606	1-161-494-00	(W285)...CAP,CERAMIC	0.022MF			
C607	1-161-494-00	(W285)...CAP,CERAMIC	0.022MF			
CN301	*1-564-507-11	PLUG, CONNECTOR 4P				
CN302	*1-564-509-11	PLUG, CONNECTOR 6P				
CN321	*1-566-856-11	(W285)...SOCKET, CONNECTOR 5P (SYSTEM CONTROL 2)				
CN401	*1-564-505-11	PLUG, CONNECTOR 2P				
CN501	*1-564-509-11	PLUG, CONNECTOR 6P				
CN502	*1-564-511-11	PLUG, CONNECTOR 8P				

Ref.No.	Part No.	Description
CN503	*1-566-210-11	(W380)...PIN, CONNECTOR 3P (SYSTEM CONTROL IN)
CN504	*1-564-505-21	PLUG, CONNECTOR 2P
CN505	*1-564-505-21	PLUG, CONNECTOR 2P
CN601	*1-566-856-11	(W285)...SOCKET, CONNECTOR 5P (SYSTEM CONTROL 1)
CN602	*1-564-505-11	(W380)...PLUG, CONNECTOR 2P
CNP1	△.1-558-945-11	(W380)...CORD, POWER (POLAR.SPT-1)
CT401	1-141-225-00	CAP, TUNING, TRIMAR
D191	8-719-302-45	DIODE SEL1210S
D192	8-719-302-45	DIODE SEL1210S
D193	8-719-302-45	DIODE SEL1210S
D194	8-719-302-45	DIODE SEL1210S
D195	8-719-302-45	DIODE SEL1210S
D291	8-719-302-45	DIODE SEL1210S
D292	8-719-302-45	DIODE SEL1210S
D293	8-719-302-45	DIODE SEL1210S
D294	8-719-302-45	DIODE SEL1210S
D295	8-719-302-45	DIODE SEL1210S
D401	8-719-000-26	DIODE US1060M
D402	8-719-000-26	DIODE US1060M
D501	8-719-000-26	DIODE US1060M
D504	8-719-000-26	DIODE US1060M
D505	8-719-000-26	DIODE US1060M
D506	8-719-000-26	DIODE US1060M
D507	8-719-000-26	DIODE US1060M
D509	8-719-000-26	(W380)...DIODE US1060M
D510	8-719-000-26	DIODE US1060M
D511	8-719-000-26	(W380)...DIODE US1060M
D512	8-719-000-26	DIODE US1060M
D514	8-719-302-45	DIODE SEL1210S (RECORD)
D515	8-719-941-46	(W380)...DIODE SEL1910A (REMOTE PAUSE)
D601	8-719-200-02	(W380)...DIODE 10E2
D602	8-719-200-02	(W380)...DIODE 10E2
D603	8-719-200-02	(W380)...DIODE 10E2
D604	8-719-200-02	(W380)...DIODE 10E2
D605	8-719-001-60	DIODE UZL-12L1
HE401	1-543-261-11	HEAD, ERASE (886-01-24)
HP101	1-543-424-11	HEAD, MAGNETIC (PB)
HRP101	1-543-424-11	HEAD, MAGNETIC (REC/PB)
IC191	8-759-917-42	IC IR2E31A
IC291	8-759-917-42	IC IR2E31A
IC301	8-759-800-36	IC LA3160
IC302	8-759-800-36	IC LA3160
IC303	8-759-601-43	IC M4066BP
IC322	8-752-031-67	IC CXA1100P

Ref.No.	Part No.	Description
IC341	8-752-033-61	IC CXA1198AP
IC342	8-759-140-51	IC UPD4051BC
IC501	8-759-601-10	IC M4011BP
IC502	8-759-601-06	IC M4001BP
J321	1-565-258-21	JACK, PIN 4P (LINE IN/LINE OUT)
L131	1-410-780-11	INDUCTOR 27MMH
L231	1-410-780-11	INDUCTOR 27MMH
M901	X-3390-801-1	MOTOR ASSY
M902	X-3390-801-1	MOTOR ASSY
Q101	8-729-900-89	TRANSISTOR DTC144ES
Q121	8-729-178-54	TRANSISTOR 2SC2785
Q141	8-729-178-54	TRANSISTOR 2SC2785
Q201	8-729-900-89	TRANSISTOR DTC144ES
Q221	8-729-178-54	TRANSISTOR 2SC2785
Q241	8-729-178-54	TRANSISTOR 2SC2785
Q321	8-729-900-89	TRANSISTOR DTC144ES
Q401	8-729-194-57	TRANSISTOR 2SC945
Q402	8-729-194-57	TRANSISTOR 2SC945
Q403	8-729-281-52	TRANSISTOR 2SC1815Y
Q404	8-729-115-12	TRANSISTOR BN1L4M
Q405	8-729-900-80	TRANSISTOR DTC114ES
Q501	8-729-115-12	TRANSISTOR BN1L4M
Q502	8-729-115-12	TRANSISTOR BN1L4M
Q503	8-729-900-61	(W380)...TRANSISTOR DTA114ES
Q504	8-729-801-53	(W380)...TRANSISTOR 2SD1387
Q505	8-729-900-89	(W380)...TRANSISTOR DTC144ES
Q506	8-729-115-12	(W380)...TRANSISTOR BN1L4M
Q507	8-729-900-89	TRANSISTOR DTC144ES
Q508	8-729-900-80	(W380)...TRANSISTOR DTC114ES
Q509	8-729-115-12	TRANSISTOR BN1L4M
Q510	8-729-900-61	(W380)...TRANSISTOR DTA114ES
Q511	8-729-900-89	(W380)...TRANSISTOR DTC144ES
Q601	8-729-107-25	(W380)...TRANSISTOR 2SD1585-L
Q602	8-729-209-15	TRANSISTOR 2SD2012
R101	1-247-889-00	CARBON 270K 5% 1/4W
R102	1-249-404-00	CARBON 82 5% 1/4W
R103	1-247-883-00	CARBON 150K 5% 1/4W
R104	1-249-426-11	CARBON 5.6K 5% 1/4W
R106	1-247-889-00	CARBON 270K 5% 1/4W
R107	1-249-404-00	CARBON 82 5% 1/4W
R108	1-247-883-00	CARBON 150K 5% 1/4W
R109	1-249-426-11	CARBON 5.6K 5% 1/4W
R110	1-249-430-11	CARBON 12K 5% 1/4W
R111	1-249-431-11	CARBON 15K 5% 1/4W
R112	1-247-887-00	CARBON 220K 5% 1/4W
R113	1-249-441-11	CARBON 100K 5% 1/4W

**Note:**

The components identified by mark  or dotted line with mark  are critical for safety. Replace only with part number specified.

**Note:**

Les composants identifiés par une marque  sont critiques pour la sécurité. Ne les remplacer que par une pièce portant le numéro spécifié.

Ref.No.	Part No.	Description			
R114	1-249-441-11	CARBON	100K	5%	1/4W
R121	1-249-435-11	CARBON	33K	5%	1/4W
R122	1-249-417-11	CARBON	1K	5%	1/4W
R129	1-249-421-11	CARBON	2.2K	5%	1/4W
R130	1-249-429-11	CARBON	10K	5%	1/4W
R131	1-249-417-11	CARBON	1K	5%	1/4W
R132	1-249-429-11	CARBON	10K	5%	1/4W
R133	1-249-421-11	CARBON	2.2K	5%	1/4W
R134	1-215-452-00	CARBON	20K	5%	1/4W
R135	1-249-425-11	CARBON	4.7K	5%	1/4W
R141	1-249-428-11	CARBON	8.2K	5%	1/4W
R142	1-249-421-11	CARBON	2.2K	5%	1/4W
R144	1-249-421-11	CARBON	2.2K	5%	1/4W
R145	1-249-430-11	CARBON	12K	5%	1/4W
R191	1-249-441-11	CARBON	100K	5%	1/4W
R192	1-249-405-11	CARBON	100	5%	1/4W
R201	1-247-889-00	CARBON	270K	5%	1/4W
R202	1-249-404-00	CARBON	82	5%	1/4W
R203	1-247-883-00	CARBON	150K	5%	1/4W
R204	1-249-426-11	CARBON	5.6K	5%	1/4W
R206	1-247-889-00	CARBON	270K	5%	1/4W
R207	1-249-404-00	CARBON	82	5%	1/4W
R208	1-247-883-00	CARBON	150K	5%	1/4W
R209	1-249-426-11	CARBON	5.6K	5%	1/4W
R210	1-249-430-11	CARBON	12K	5%	1/4W
R211	1-249-431-11	CARBON	15K	5%	1/4W
R212	1-247-887-00	CARBON	220K	5%	1/4W
R213	1-249-441-11	CARBON	100K	5%	1/4W
R214	1-249-441-11	CARBON	100K	5%	1/4W
R221	1-249-435-11	CARBON	33K	5%	1/4W
R222	1-249-417-11	CARBON	1K	5%	1/4W
R229	1-249-421-11	CARBON	2.2K	5%	1/4W
R230	1-249-429-11	CARBON	10K	5%	1/4W
R231	1-249-417-11	CARBON	1K	5%	1/4W
R232	1-249-429-11	CARBON	10K	5%	1/4W
R233	1-249-421-11	CARBON	2.2K	5%	1/4W
R234	1-215-452-00	CARBON	20K	5%	1/4W
R235	1-249-425-11	CARBON	4.7K	5%	1/4W
R241	1-249-428-11	CARBON	8.2K	5%	1/4W
R242	1-249-421-11	CARBON	2.2K	5%	1/4W
R244	1-249-421-11	CARBON	2.2K	5%	1/4W
R245	1-249-430-11	CARBON	12K	5%	1/4W
R291	1-249-441-11	CARBON	100K	5%	1/4W
R292	1-249-405-11	CARBON	100	5%	1/4W
R301	1-247-743-11	CARBON	220	5%	1/2W



Ref.No.	Part No.	Description			
R302	1-247-743-11	CARBON	220	5%	1/2W
R321	1-249-433-11	CARBON	22K	5%	1/4W
R322	1-215-460-00	METAL	43K	1%	1/6W
R323	1-215-466-00	CARBON	75K	5%	1/4W
R324	1-249-405-11	CARBON	100	5%	1/4W
R341	1-249-441-11	CARBON	100K	5%	1/4W
R342	1-215-454-00	CARBON	24K	5%	1/4W
R343	1-247-881-00	CARBON	120K	5%	1/4W
R344	1-247-883-00	CARBON	150K	5%	1/4W
R345	1-249-441-11	CARBON	100K	5%	1/4W
R346	1-249-437-11	CARBON	47K	5%	1/4W
R347	1-249-434-11	CARBON	27K	5%	1/4W
R348	1-249-437-11	CARBON	47K	5%	1/4W
R349	1-215-462-00	CARBON	51K	5%	1/4W
R350	1-249-438-11	CARBON	56K	5%	1/4W
R351	1-249-436-11	CARBON	39K	5%	1/4W
R352	1-249-438-11	CARBON	56K	5%	1/4W
R353	1-249-437-11	CARBON	47K	5%	1/4W
R354	1-249-439-11	CARBON	68K	5%	1/4W
R355	1-249-439-11	CARBON	68K	5%	1/4W
R356	1-249-439-11	CARBON	68K	5%	1/4W
R357	1-249-439-11	CARBON	68K	5%	1/4W
R358	1-249-436-11	CARBON	39K	5%	1/4W
R359	1-249-434-11	CARBON	27K	5%	1/4W
R360	1-249-437-11	CARBON	47K	5%	1/4W
R361	1-249-441-11	CARBON	100K	5%	1/4W
R362	1-249-440-11	CARBON	82K	5%	1/4W
R363	1-215-472-00	CARBON	130K	5%	1/4W
R364	1-215-462-00	CARBON	51K	5%	1/4W
R365	1-215-464-00	CARBON	62K	5%	1/4W
R366	1-249-436-11	CARBON	39K	5%	1/4W
R367	1-249-439-11	CARBON	68K	5%	1/4W
R368	1-249-439-11	CARBON	68K	5%	1/4W
R369	1-215-466-00	CARBON	75K	5%	1/4W
R370	1-249-437-11	CARBON	47K	5%	1/4W
R371	1-249-438-11	CARBON	56K	5%	1/4W
R372	1-249-438-11	CARBON	56K	5%	1/4W
R373	1-249-441-11	CARBON	100K	5%	1/4W
R374	1-247-887-00	CARBON	220K	5%	1/4W
R375	1-249-436-11	CARBON	39K	5%	1/4W
R376	1-247-881-00	CARBON	120K	5%	1/4W
R377	1-247-885-00	CARBON	180K	5%	1/4W
R378	1-247-883-00	CARBON	150K	5%	1/4W
R379	1-249-437-11	CARBON	47K	5%	1/4W
R380	1-249-437-11	CARBON	47K	5%	1/4W

Ref.No.	Part No.	Description			
R381	1-249-437-11	CARBON	47K	5%	1/4W
R391	1-249-414-11	CARBON	560	5%	1/4W
R401	1-249-393-11	CARBON	10	5%	1/4W
R402	1-249-433-11	CARBON	22K	5%	1/4W
R403	1-249-433-11	CARBON	22K	5%	1/4W
R404	1-249-429-11	CARBON	10K	5%	1/4W
R405	1-249-417-11	CARBON	1K	5%	1/4W
R406	1-249-433-11	CARBON	22K	5%	1/4W
R408	1-249-429-11	CARBON	10K	5%	1/4W
R409	1-249-427-11	CARBON	6.8K	5%	1/4W
R410	1-249-411-11	CARBON	330	5%	1/4W
R501	1-249-420-11	CARBON	1.8K	5%	1/4W
R502	1-249-408-11	CARBON	180	5%	1/4W
R503	1-249-435-11	CARBON	33K	5%	1/4W
R504	1-249-420-11	CARBON	1.8K	5%	1/4W
R505	1-249-408-11	CARBON	180	5%	1/4W
R506	1-249-435-11	CARBON	33K	5%	1/4W
R507	1-249-393-11	(W380)...CARBON	10	5%	1/4W
R509	1-249-433-11	CARBON	22K	5%	1/4W
R510	1-249-427-11	CARBON	6.8K	5%	1/4W
R511	1-249-435-11	CARBON	33K	5%	1/4W
R512	1-249-437-11	CARBON	47K	5%	1/4W
R513	1-249-429-11	CARBON	10K	5%	1/4W
R514	1-249-441-11	CARBON	100K	5%	1/4W
R515	1-249-417-11	CARBON	1K	5%	1/4W
R516	1-249-442-11	(W380)...CARBON	510	5%	1/4W
R517	1-249-421-11	(W380)...CARBON	2.2K	5%	1/4W
R518	1-249-417-11	(W380)...CARBON	1K	5%	1/4W
R519	1-249-435-11	(W380)...CARBON	33K	5%	1/4W
R520	1-249-429-11	CARBON	10K	5%	1/4W
R521	1-249-417-11	(W380)...CARBON	1K	5%	1/4W
R603	1-249-413-11	CARBON	470	5%	1/4W
R604	1-249-413-11	CARBON	470	5%	1/4W
RV101	1-228-994-00	RES, ADJ, CARBON 10K(PB LEVEL ,L ,DECK A)			
RV102	1-228-994-00	RES, ADJ, CARBON 10K(PB LEVEL ,L ,DECK B)			
RV141	1-228-995-00	RES, ADJ, CARBON 22K(REC LEVEL ,L)			
RV201	1-228-994-00	RES, ADJ, CARBON 10K(PB LEVEL ,R ,DECK A)			
RV202	1-228-994-00	RES, ADJ, CARBON 10K(PB LEVEL ,R ,DECK B)			
RV241	1-228-995-00	RES, ADJ, CARBON 22K(REC LEVEL ,R)			
RV321	1-238-150-11	RES, VAR, CARBON 20K/20K (REC LEVEL)			
RV501	1-228-991-00	RES, ADJ, CARBON 2.2K(HIGH SPEED ,DECK A)			
RV502	1-228-990-00	RES, ADJ, CARBON 1K(NORMAL SPEED ,DECK A)			
RV503	1-228-991-00	RES, ADJ, CARBON 2.2K(HIGH SPEED ,DECK B)			
RV504	1-228-990-00	RES, ADJ, CARBON 1K(NORMAL SPEED ,DECK B)			
RY401	1-515-614-11	RELAY (REC/PB)			

Ref.No.	Part No.	Description
S301	1-571-523-11	SWITCH, PUSH (2 KEY)(TAPE ,DECK B)
S302	1-570-393-11	SWITCH, PUSH 1 KEY)(TAPE ,DECK A)
S303	1-571-510-11	SWITCH, PUSH (1 KEY)(DOLBY NR)
S501	1-571-510-11	SWITCH, PUSH 1 KEY DUBBING SPEED
S601	1-570-393-11	(W380)...SWITCH, PUSH (1 KEY)(POWER)
S901	1-570-715-11	SWITCH, LEAF (MOTOR A)
S902	1-570-716-11	SWITCH, LEAF (FWD A)
S903	1-570-715-11	SWITCH, LEAF (MOTOR B)
S904	1-570-716-11	SWITCH, LEAF (FWD B)
S905	1-571-037-11	SWITCH, LEAF (REC SW)
T401	1-433-303-11	TRANSFORMER, BIAS OSCILLATION
T601	△.1-449-256-11	(W380)...TRANSFORMER, POWER

ACCESSORY & PACKING MATERIAL (TC-W380 ONLY)

1-558-787-21	CORD, CONNECTION
1-558-844-11	CORD (WITH CONNECTOR) 3P
3-703-450-01	INSTRUCTION
3-769-973-21	MANUAL, INSTRUCTION
*3-327-844-81	INDIVIDUAL CARTON

**Note:**  
The components identified by mark  or dotted line with mark  are critical for safety. Replace only with part number specified.

**Note:**  
Les composants identifiés par une marque  sont critiques pour la sécurité. Ne les remplacer que par une pièce portant le numéro spécifié.

# Troubleshooting Guide

Before proceeding with these trouble checks, first confirm the following basic points:

- The power cord is firmly connected.
- The amplifier connections are firmly made.
- The heads, capstans and pinch rollers are clean.
- The amplifier controls and switches are set correctly.

FUNCTION BUTTONS AND TAPE TRANSPORT PROBLEMS		
Symptom	Cause	Remedy
Function buttons do not activate.	Cassette holder is not fully closed.	Close the holder completely.
	The REMOTE PAUSE indicator is lit. (TC-W380)	Press <b>II</b> on the remote commander to release the pause mode.
The <b>II</b> -button on the remote commander does not activate. (The REMOTE PAUSE indicator does not light up.)	The system control cord (3-pin) is not connected.	Connect the cord firmly.
● button does not activate.	No cassette in the holder.	Insert a cassette.
	Tab has been removed from the cassette.	Cover the hole with plastic tape.
Automatic shut-off mechanism activates before the tape comes to its end.	Tape is slack.	Take up the tape slack.
	Cassette shell is deformed.	Use another cassette.
Excessively loud tape transport noise when rewinding or fast-forwarding	This depends on the cassette used and is not a problem.	—

RECORDING AND PLAYBACK PROBLEMS		
Symptom	Cause	Remedy
Recording or playback cannot be made or there is a decrease in sound level.	Record/playback and erase heads are either dirty or magnetized.	Clean or demagnetize the heads.
	Improper connection	Make connections properly.
	Improper setting of the amplifier controls	Set the amplifier controls to the appropriate positions.
Excessive wow, flutter or dropout	Head, capstan or pinch roller is dirty.	Clean in accordance with instructions shown on "Maintenance".
Incomplete erasure	Erase head is dirty.	Clean the erase head.
Increased noise or poor reproduction in high frequencies	Head is magnetized.	Demagnetize the head.
Unbalanced tone in high frequencies	Improper setting of the DOLBY NR switch.	When playing back, set the switch to the same position used in recording.
	Improper setting of the TAPE selector(s).	If recorded with the wrong selector setting, adjust the tone controls of the amplifier in playback.

NOISE		
Symptom	Cause	Remedy
Hum noise	The deck is stacked on or under the amplifier.	Separate the units.
Noise is recorded.	Recording was made near such equipment as a television set or a color monitor, and the interference has affected the recording on the tape and the Dolby NR system.	Move the unit away from television set or color monitor.



# TC-W285/W380

## SONY<sup>®</sup> SERVICE MANUAL

US Model  
TC-W285  
TC-W380

Canadian Model  
E Model  
Italian Model  
TC-W285

### SUPPLEMENT-1

File this supplement with the service manual.

Revise your service manual as shown below due to parts supply classification has been changed.

(SPM-94026)

 : indicates revised portion.

Page 12

(2) DECK A (1)  
(TCM-YM47CW45)

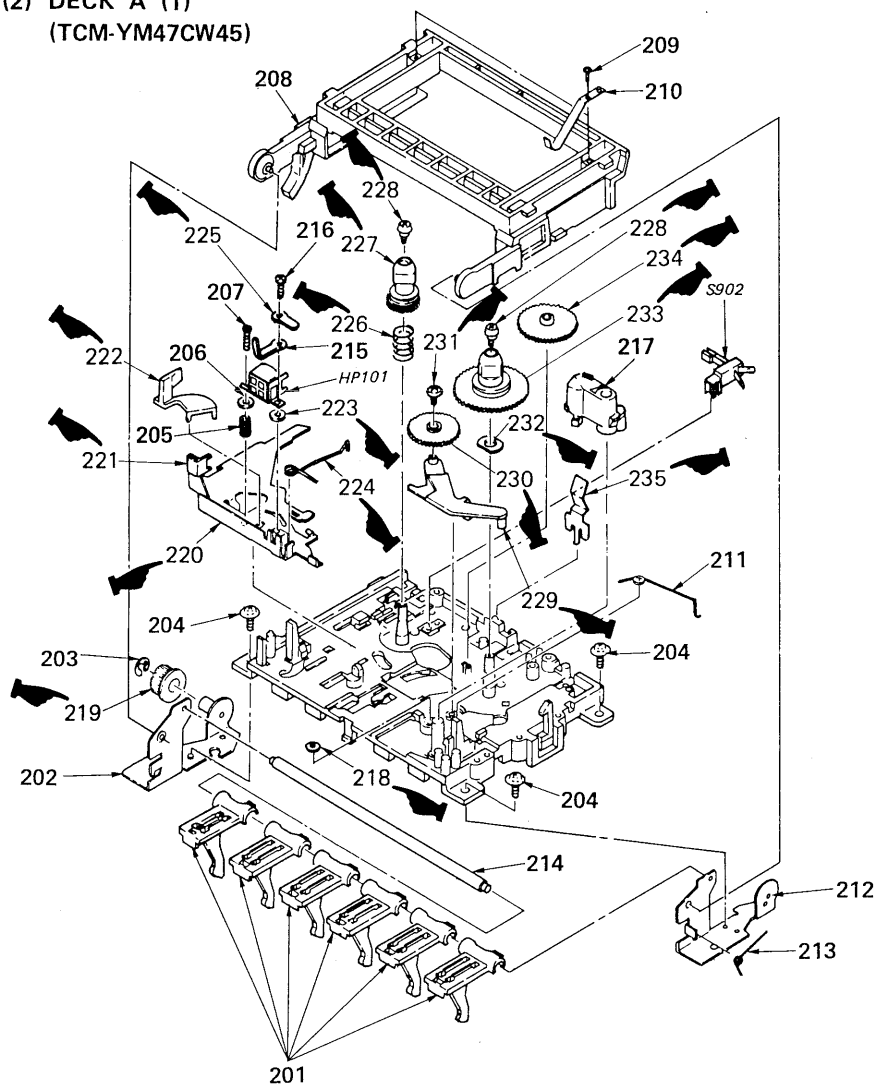

Ref. No.	Part No.	Description
218	4-894-969-01	N WASHER
219	4-895-001-01	GEAR
* 220	4-895-015-01	HEAD BASE
221	4-895-016-01	TAPE GUIDE
222	4-894-956-01	TAPE SENSOR
223	3-390-821-01	SPACER
* 224	3-390-804-01	SPRING, PINCH ARM
* 225	3-390-819-01	LUG
226	4-894-954-01	C SPRING
227	4-894-953-01	S REEL
228	3-390-803-01	BUSHING (D)
229	4-894-962-01	IDLER ARM
230	4-894-961-01	IDLER GEAR
231	4-894-960-01	BUSH
232	3-390-820-01	SPRING, LEAF
233	4-894-963-01	T REEL ASSY
234	4-894-964-01	F GEAR
235	4-894-966-01	SPRING

(3) DECK A (2)

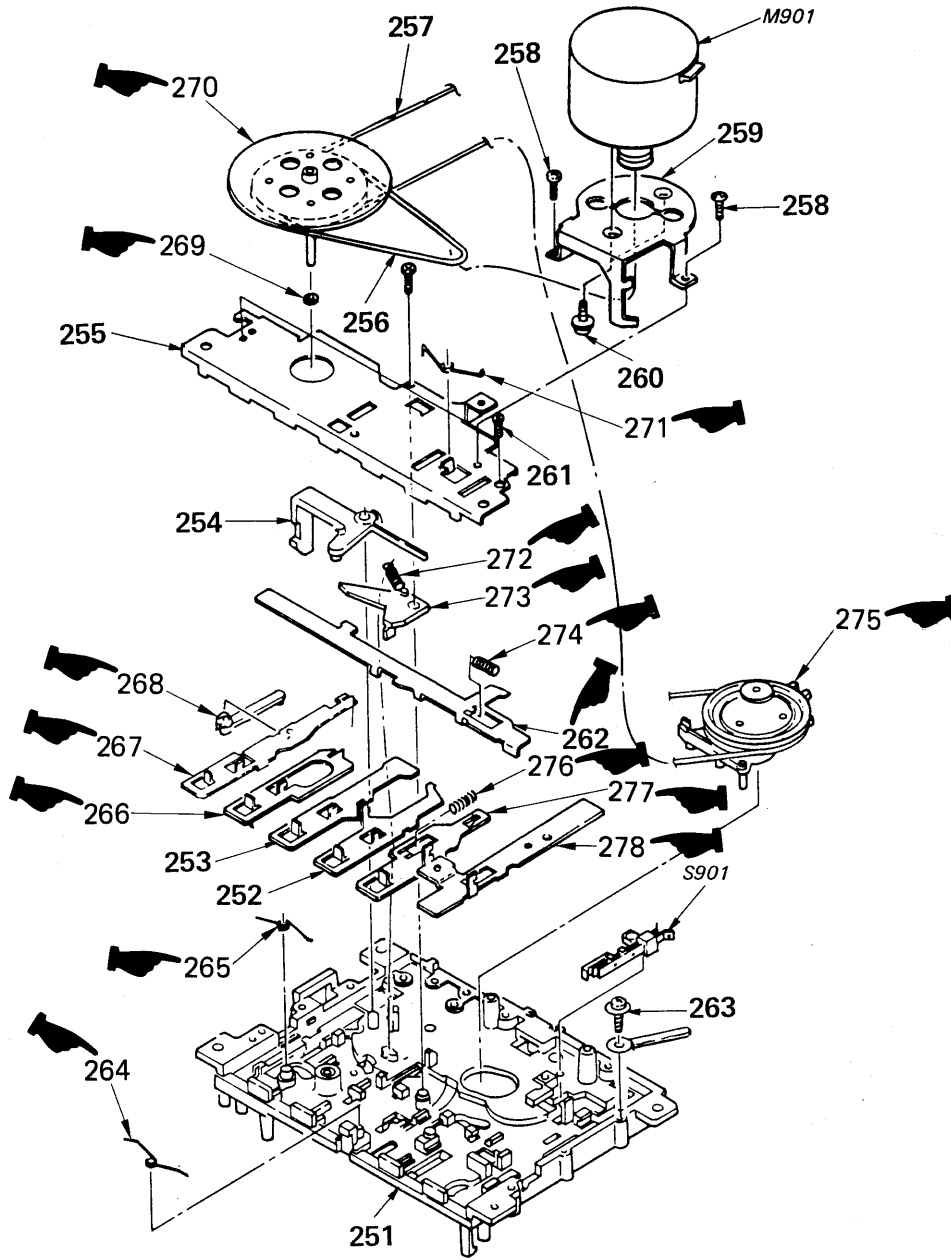

Ref. No.	Part No.	Description	Remark	Ref. No.	Part No.	Description	Remark
* 262	4-894-984-01	FUNCTION LEVER		271	4-894-978-01	SPRING	
264	4-894-999-01	SPRING		272	3-390-809-01	SPRING	
265	4-894-989-01	SPRING		273	4-894-982-01	S ARM	
* 266	4-894-987-01	S. E LEVER		274	4-894-983-01	C SPRING	
* 267	4-894-986-01	PAUSE LEVER		275	4-894-997-01	POWER ARM ASSY	
268	4-894-985-01	PAUSE ARM		276	3-390-827-01	SPRING	
269	4-894-976-01	P WASHER		277	3-390-810-01	LEVER, PLAY	
270	3-390-806-01	FW ASSY		278	4-894-994-01	REC LEVER	

(4) DECK B (1)  
(TCM-YM47CW46)

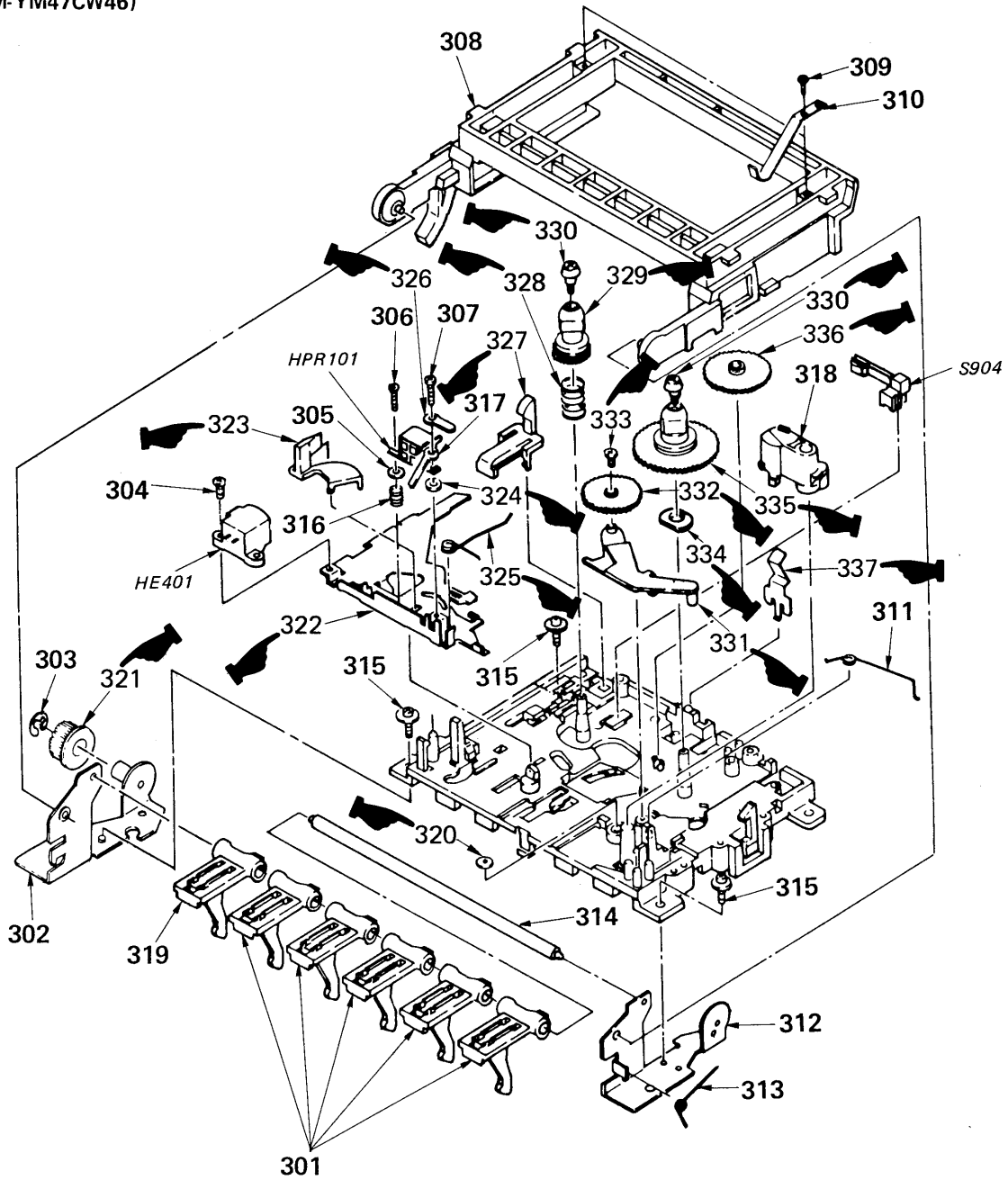

Ref. No.	Part No.	Description	Remark	Ref. No.	Part No.	Description	Remark
320	4-894-969-01	N WASHER		329	4-894-953-01	S REEL	
321	4-895-001-01	GEAR		330	3-390-803-01	BUSHING (D)	
* 322	4-894-957-01	HEAD BASE B		331	4-894-962-01	IDLER ARM	
323	4-894-956-01	TAPE SENSOR		332	4-894-961-01	IDLER GEAR	
324	3-390-821-01	SPACER		333	4-894-960-01	BUSH	
* 325	3-390-804-01	SPRING, PINCH ARM		334	3-390-820-01	SPRING, LEAF	
* 326	3-390-819-01	LUG		335	4-894-963-01	T REEL ASSY	
327	4-894-958-01	INTERLOCK ARM		336	4-894-964-01	F GEAR	
328	4-894-954-01	C SPRING		337	4-894-966-01	SPRING	

(5) DECK B (2)

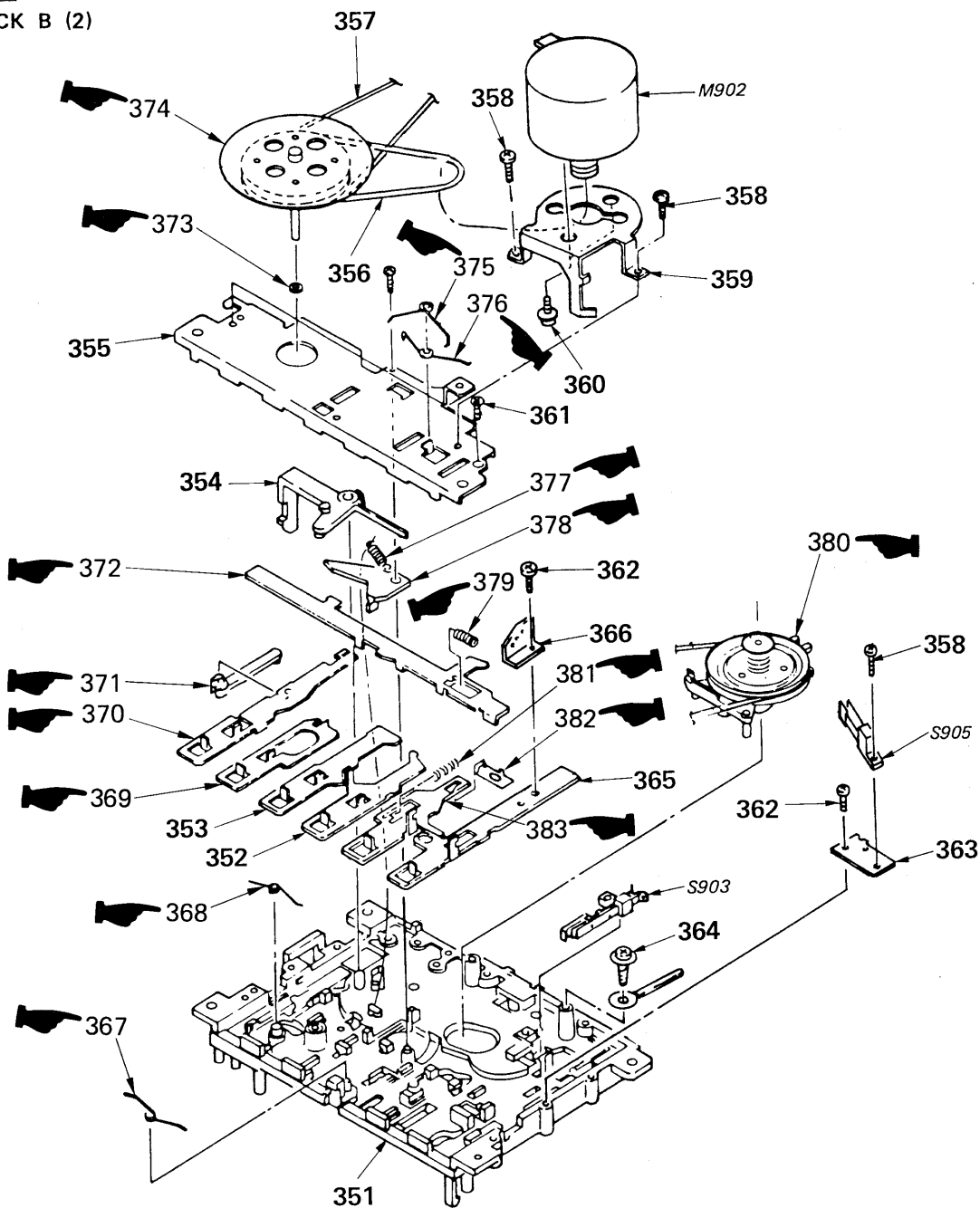

Ref. No.	Part No.	Description	Remark	Ref. No.	Part No.	Description	Remark
367	4-894-999-01	SPRING		376	4-894-979-01	SPRING	
368	4-894-989-01	SPRING		377	3-390-809-01	SPRING	
* 369	4-894-987-01	S. E LEVER		378	4-894-982-01	S ARM	
* 370	4-894-986-01	PAUSE LEVER		379	4-894-983-01	C SPRING	
371	4-894-985-01	PAUSE ARM		380	4-894-997-01	POWER ARM ASSY	
* 372	4-894-984-01	FUCTION LEVER		381	3-390-827-01	SPRING	
373	4-894-976-01	P WASHER		382	3-390-811-01	LEVER, REC STOP	
374	3-390-806-01	FW ASSY		383	3-390-810-01	LEVER, PLAY	
375	4-894-978-01	SPRING					

**Sony Corporation**  
 Consumer A&V Products Company  
 Home A&V Products Div.

English  
 94L0553-1  
 Printed in Japan  
 © 1994. 12