

TC-W190/W300

SERVICE MANUAL

US Model

TC-W190

US Model

Canadian Model

AEP Model

UK Model

E Model

TC-W300

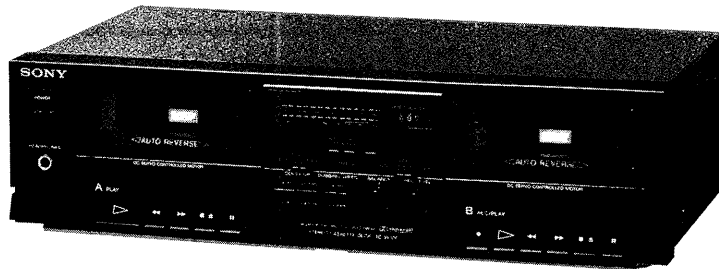

Photo : TC-W300

SPECIFICATIONS

Recording system 4-track 2-channel stereo
 Fast-forward and rewind time
 Approx. 90 sec. (with C-60 cassette)
 Bias AC bias
 Signal-to-noise ratio (NAB, at peak level)

Cassette	Dolby NR switch		
	OFF	B-TYPE ON	C-TYPE ON (TC-W300)
TYPE IV (Sony METAL-ES)	58 dB	65 dB	71 dB
TYPE II (Sony UX-S)	56 dB	63 dB	69 dB
TYPE I (Sony HF-S)	54 dB	61 dB	67 dB

Total harmonic distortion
 1.0% (with Sony METAL-ES cassettes)

Frequency response (DOLBY NR OFF)

TYPE IV cassette (Sony METAL-ES)	30-15,000 Hz (± 3 dB, DIN)
TYPE II cassette (Sony UX-S)	30-14,000 Hz (± 3 dB, DIN)
TYPE I cassette (Sony HF-S)	30-13,000 Hz (± 3 dB, DIN)

Wow and flutter 0.12% WRMS (NAB)
 $\pm 0.2\%$ (DIN)

Inputs

Line inputs (phono jacks)	Sensitivity	77.5 mV (-20 dB)
	Input impedance	50 k ohms

Model Name Using Similar Mechanism	New
Tape Transport Mechanism Type	DECK A : TCM-YM47CW-61 DECK B : TCM-YM47CW-60

Outputs

Line outputs (phono jacks)	Rated output level	0.44 V (-5 dB) at a load impedance 47 k ohms
	Load impedance	Over 10 k ohms
Headphone output (stereo phone jack)	Output level	0.28 mW at a load impedance of 32 ohms

General

Power requirements

US, Canadian model: 120 V AC, 60 Hz
 AEP model: 220 V AC, 50/60 Hz
 UK model: 240 V AC, 50/60 Hz
 E model:
 120V, 220V or 240V AC adjustable, 50/60Hz

Power consumption

15 W

Dimensions

Approx. 430 × 117.5 × 250 mm (w/h/d)
 (17 × 4³/₄ × 9⁷/₈ inches)

Weight

including projecting parts and controls
 Approx. 3.4 kg (7 lbs 8 oz)

Supplied accessories

Audio connecting cord (2)

STEREO CASSETTE DECK
SONY[®]

SAFETY CHECK-OUT

After correcting the original service problem, perform the following safety check before releasing the set to the customer:

Check the antenna terminals, metal trim, "metallized" knobs, screws, and all other exposed metal parts for AC leakage. Check leakage as described below.

LEAKAGE TEST

The AC leakage from any exposed metal part to earth ground and from all exposed metal parts to any exposed metal part having a return to chassis, must not exceed 0.5 mA (500 microampers). Leakage current can be measured by any one of three methods.

1. A commercial leakage tester, such as the Simpson 229 or RCA WT-540A. Follow the manufacturers' instructions to use these instruments.
2. A battery-operated AC milliammeter. The Data Precision 245 digital multimeter is suitable for this job.
3. Measuring the voltage drop across a resistor by means of a VOM or battery-operated AC voltmeter. The "limit" indication is 0.75 V, so analog meters must have an accurate low-voltage scale. The Simpson 250 and Sanwa SH-63Trd are examples of a passive VOM that is suitable. Nearly all battery operated digital multimeters that have a 2V AC range are suitable. (See Fig. A)

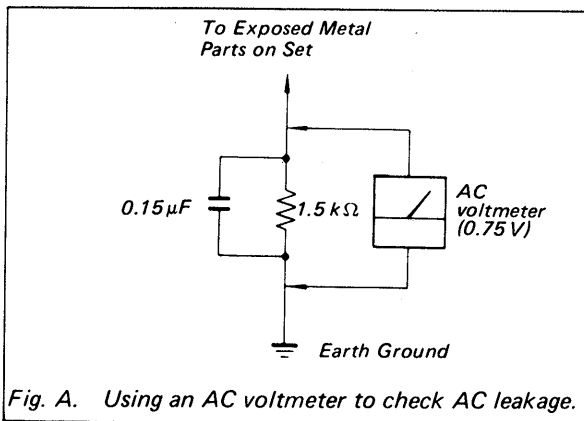

SAFETY-RELATED COMPONENT WARNING!!

COMPONENTS IDENTIFIED BY MARK \triangle OR DOTTED LINE WITH MARK \triangle ON THE SCHEMATIC DIAGRAMS AND IN THE PARTS LIST ARE CRITICAL TO SAFE OPERATION. REPLACE THESE COMPONENTS WITH SONY PARTS WHOSE PART NUMBERS APPEAR AS SHOWN IN THIS MANUAL OR IN SUPPLEMENTS PUBLISHED BY SONY.

—MODEL IDENTIFICATION— (Specification Label)

TC-W190:

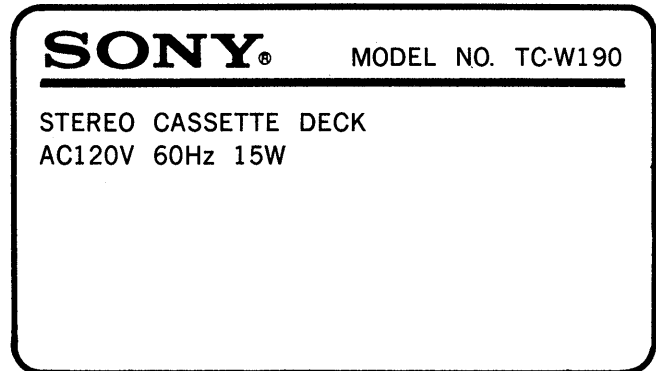

TC-W300:

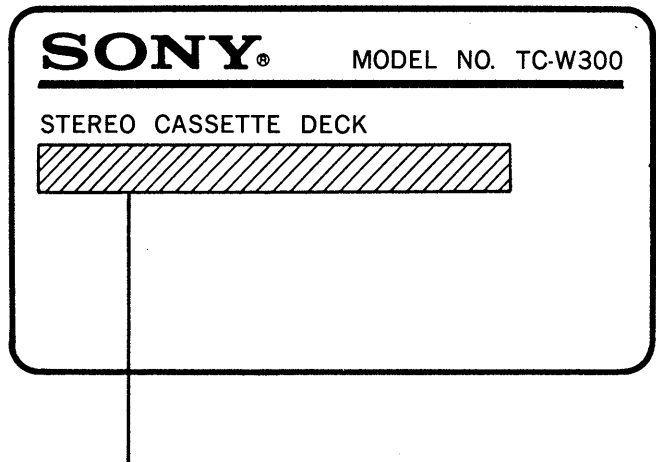

US, Canadian model: AC120V 60Hz 15W
AEP model: AC220V~50/60Hz 15W
UK model: AC240V~50/60Hz 15W
E model: AC120, 220,240V~50/60Hz 15W

ATTENTION AU COMPOSANT AYANT RAPPORT À LA SÉCURITÉ!

LES COMPOSANTS IDENTIFIÉS PAR UNE MARQUE \triangle SUR LES DIAGRAMMES SCHÉMATIQUES ET LA LISTE DES PIÈCES SONT CRITIQUES POUR LA SÉCURITÉ DE FONCTIONNEMENT. NE REMPLACER CES COMPOSANTS QUE PAR DES PIÈCES SONY DONT LES NUMÉROS SONT DONNÉS DANS CE MANUEL OU DANS LES SUPPLÉMENTS PUBLIÉS PAR SONY.

SECTION 1
GENERAL

1-1. LOCATION AND FUNCTION OF CONTROLS

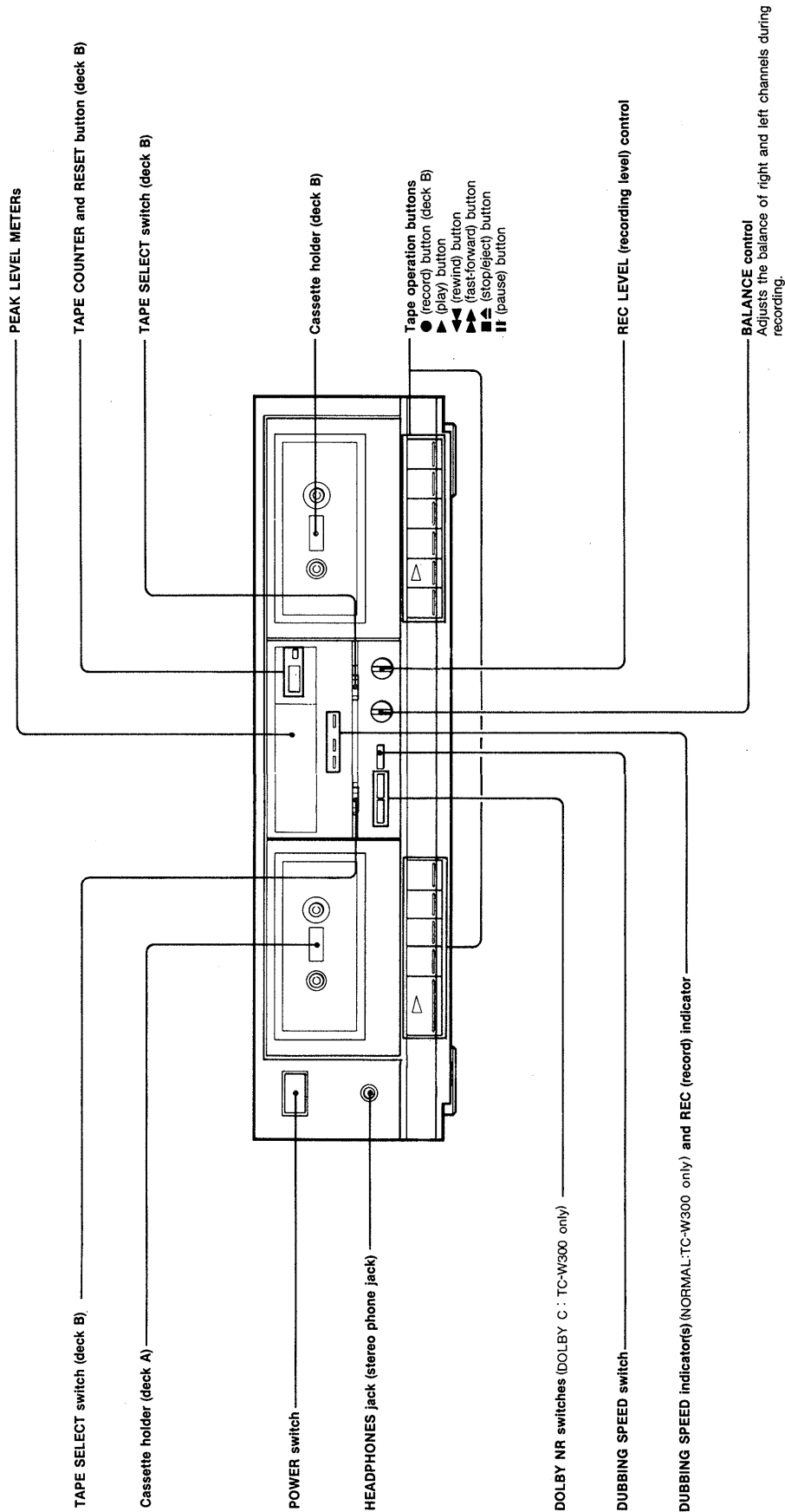

SECTION 2 MECHANICAL ADJUSTMENTS

PRECAUTION

- Clean the following parts with a denatured-alcohol-moistened swab:

record/playback head	pinch roller
erase head	rubber belts
capstan	idlers

Torque Measurement

Torque	Torque ment	Meter reading
FWD	CQ-102C	30-70g·cm (0.42-0.97oz·inch)
FWD Back tension	CQ-102C	1.5-5.5g·cm (0.020-0.076oz·inch)
FF, REW	CQ-201B	63g·cm or more (0.87oz·inch or more)

SECTION 3 ELECTRICAL ADJUSTMENTS

- Demagnetize the record/playback and erase head with a head demagnetizer.
- Do not use a magnetized screwdriver for the adjustments.
- After the adjustments, apply suitable locking compound to the parts adjusted.
- The adjustments should be performed with the rated power supply voltage unless otherwise noted.
- The adjustments should be performed in the order given in this service manual. (As a general rule, playback circuit adjustment should be completed before performing recording circuit adjustment.)
- The adjustments should be performed for both L-CH and R-CH.

- Turn the adjustment screw and check output peaks. If the peaks do not match for L-CH and R-CH, turn the adjustment screw so that outputs match within 1 dB of peak.

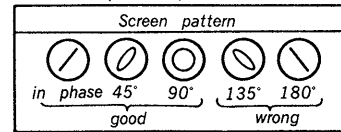
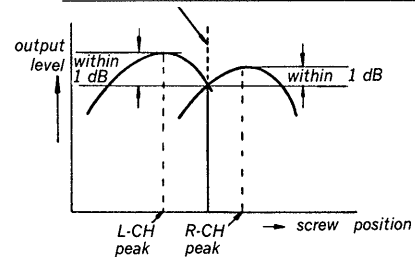

- Switches and controls should be set as follows unless otherwise specified.

DOLBY NR switch: OFF
 TAPE select switch: TYPE 1 (NORMAL)
 (DECK-B)

Mode: record

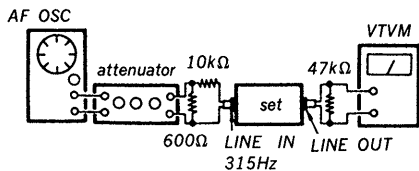

Standard Input Level

	LINE IN
source impedance	10kΩ
input level	0.25V (-10dB)

Standard Output Level

	LINE OUT
load impedance	47kΩ
output level	0.44V (-5dB)

3-1. RECORD/PLAYBACK HEAD AZIMUTH ADJUSTMENT DECK A/DECK B

Procedure:

- Mode: FWD playback

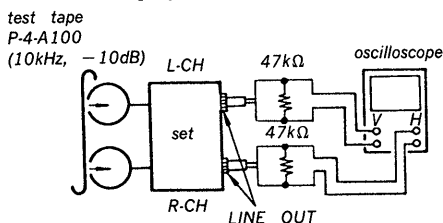

- After the adjustments, apply suitable locking compound to the parts adjusted.

Adjustment Location :

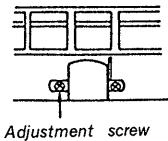

3-2. TAPE SPEED ADJUSTMENT

DECK A/DECK B

Procedure :

Mode: FWD playback

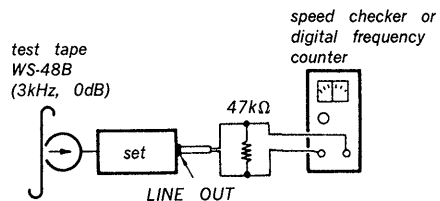

- Connect pin to with the lead wire. (CNP505)

Specification : high speed

Speed checker	Digital frequency counter
0±0.5%	5,980±30Hz

Frequency difference between the beginning and the end of the tape should be within 1.5% (90Hz).

Adjustment location :

- DECK-A side RV501
- DECK-B side RV503

2. Remove the wire in step 1. (CNP505)

Specification : normal speed

Speed checker	Digital frequency counter
0±0.3%	2,980±10Hz

Frequency difference between the beginning and the end of the tape should be within 1.5% (45Hz).

Adjustment location :

- DECK-A side RV502
- DECK-B side RV504

3. If the specifications are not satisfied, repeat step 1 and 2.

3-3. PLAYBACK LEVEL ADJUSTMENT
DECK A/DECK B

Procedure:

Mode: FWD playback

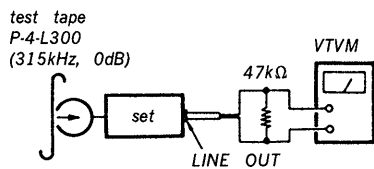

Adjust,

- DECK-A side RV101 (L-CH), RV201 (R-CH)
 - DECK-B side RV102 (L-CH), RV202 (R-CH)
- so that the specifications are satisfied.

Specification :

- LINE OUT level: 0.44V (-5dB)
- level difference between the channels: within 0.5dB

3-4. RECORD BIAS ADJUSTMENT **DECK B**

Setting :

TAPE SELECT: TYPE-I (DECK-B)

Procedure:

1. Mode: record

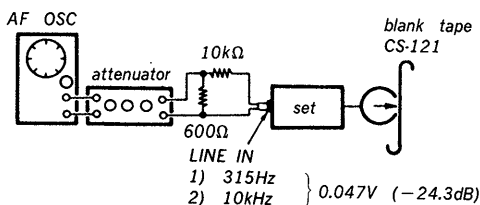

2. Mode: playback

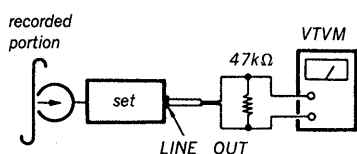

Playback the tape recorded in step 1. If the specification is not satisfied, adjust CT301 and repeat steps 1 and 2.

Specification :

The LINE OUT level of 10kHz signal relative to that of 315Hz: -0.5dB to 0.5dB.

3-5. RECORD GAIN ADJUSTMENT **DECK B**

Setting :

TAPE SELECT: TYPE-I (DECK-B)

Procedure:

1. Mode: record

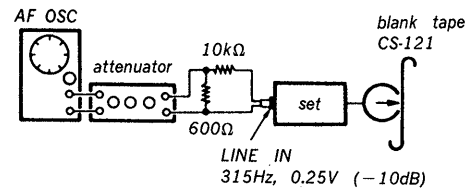

2. Mode: playback

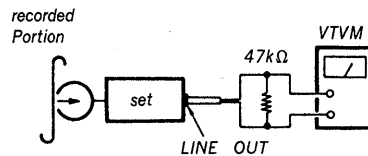

play back the recorded in step 1. If the specification is not satisfied, adjust RV103 (L-CH), RV203 (R-CH) and repeat steps 1 and 2.

Specification:

LINE OUT level: 0.44V (-5dB)

Adjustment Location : Audio Board

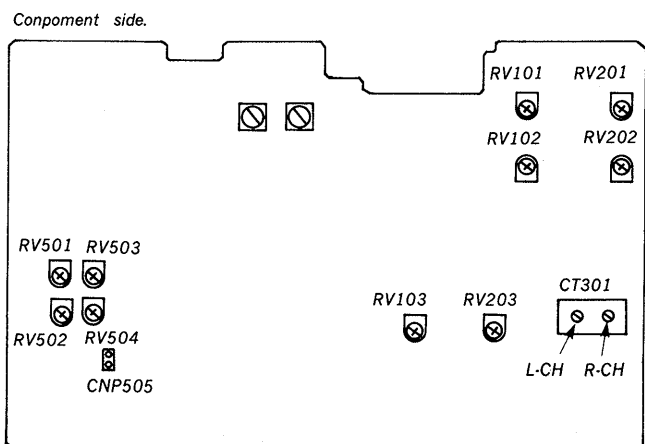

SECTION 4
DIAGRAMS

3-1. PRINTED WIRING BOARD

• Semiconductor Location

Ref. No.	Location	Ref. No.	Location
D101	B-5	Q103	E-15
D102	B-4	Q201	C-9
D103	B-4	Q202	G-9
D104	B-4	Q203	E-15
D105	B-3	Q301	D-4
D106	B-3	Q302	E-4
D107	B-3	Q303	E-4
D201	B-5	Q304	H-8
D202	B-4	Q305	G-8
D203	B-4	Q306	G-8
D204	B-4	Q307	H-8
D205	B-3	Q308	F-8
D206	B-3	Q501	F-13
D207	B-3	Q502	Q-15
D301	D-4	Q503	G-16
D302	C-1	Q504	F-15
D303	D-4	Q505	F-16
D304	G-8	Q506	F-16
D305	E-8	Q507	E-15
D501	F-15	Q701	C-15
D502	F-11	Q702	C-15
D503	F-15	Q703	C-15
D504	F-15	Q704	B-15
D505	F-14	Q705	B-15
D506	G-12	Q706	B-15
D507	G-13		
D511	C-4		
D512	C-3:		
	(TC-W300)		
D513	C-3		
D701	C-16		
D702	C-16		
D703	B-16		
D704	B-16		
D705	C-14		
IC101	C-5		
IC201	C-3		
IC303	C-8		
IC304	E-10		
IC305	E-10		
IC306	D-16		
IC307	D-13:		
	(TC-W190)		
IC501	F-14		
IC502	F-14		
Q101	C-11		
Q102	G-10		

Note:
• Color code or sleeving over the end of the jacket.

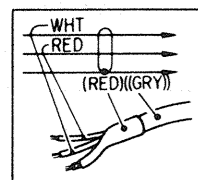

- : parts extracted from the component side.
- : parts extracted from the conductor side.
- : parts mounted on the conductor side.
- : indicates side identified with part number.

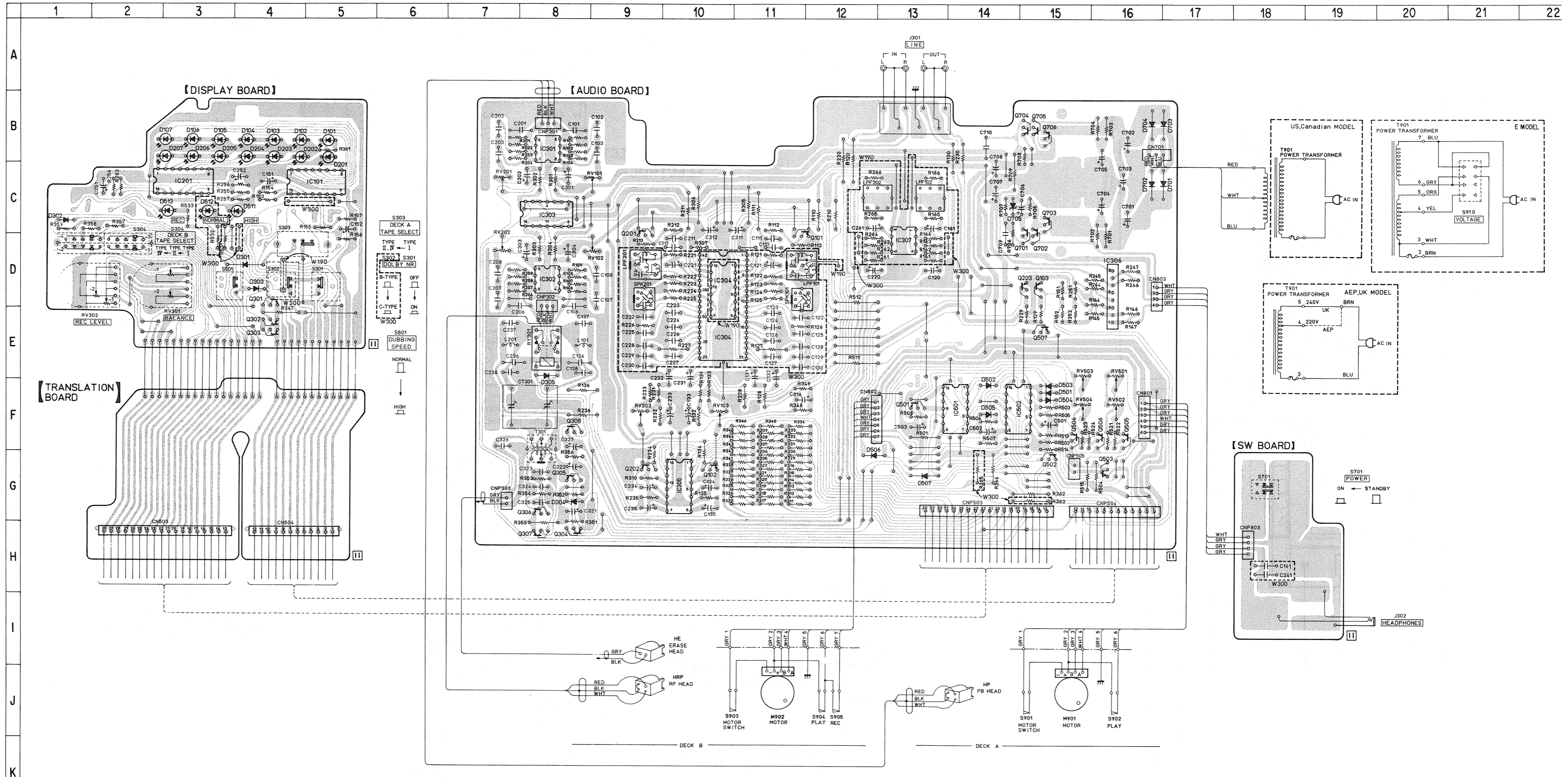

4-2. SCHEMATIC DIAGRAM

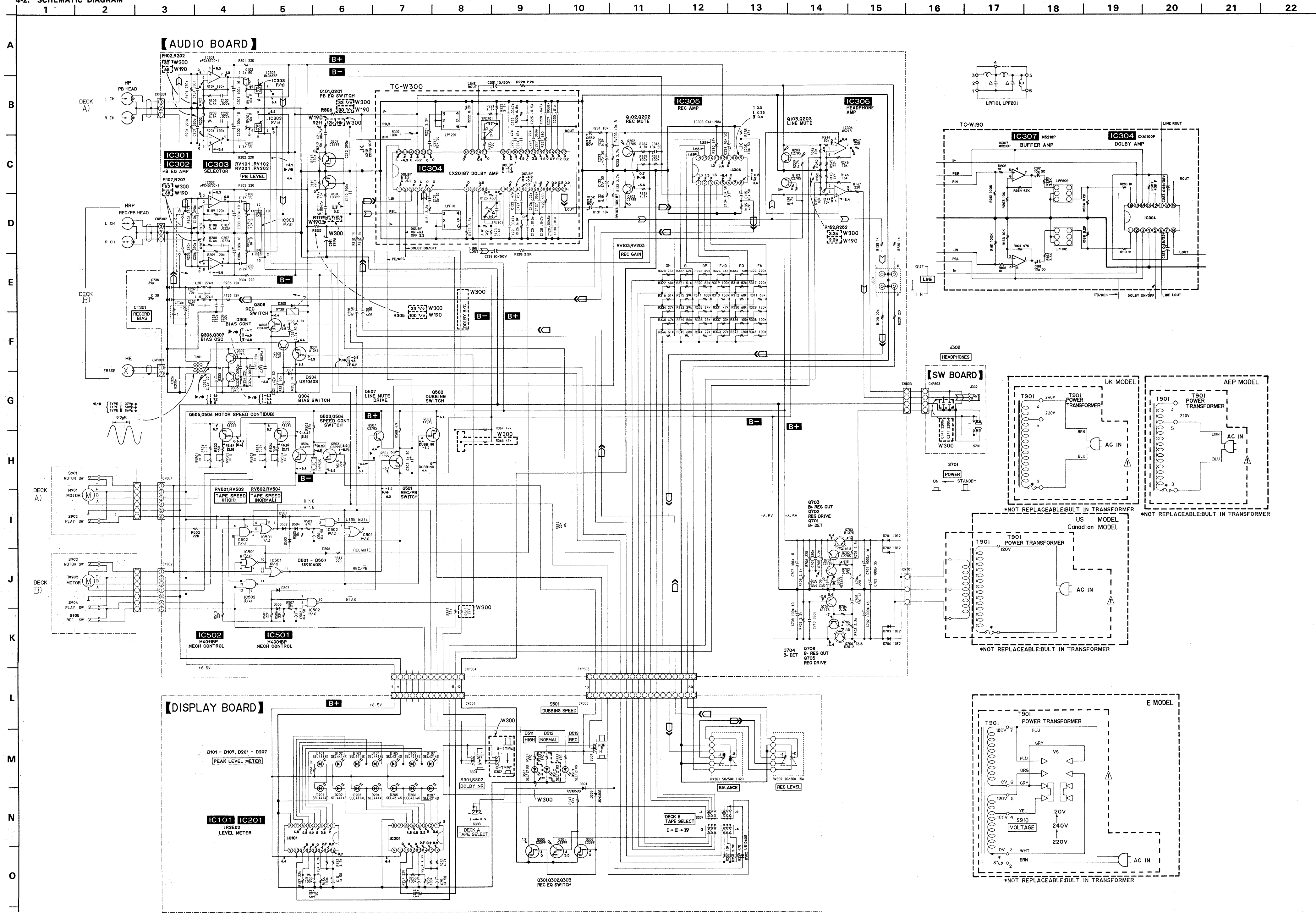

4-3. SEMICONDUCTOR LEAD LAYOUTS

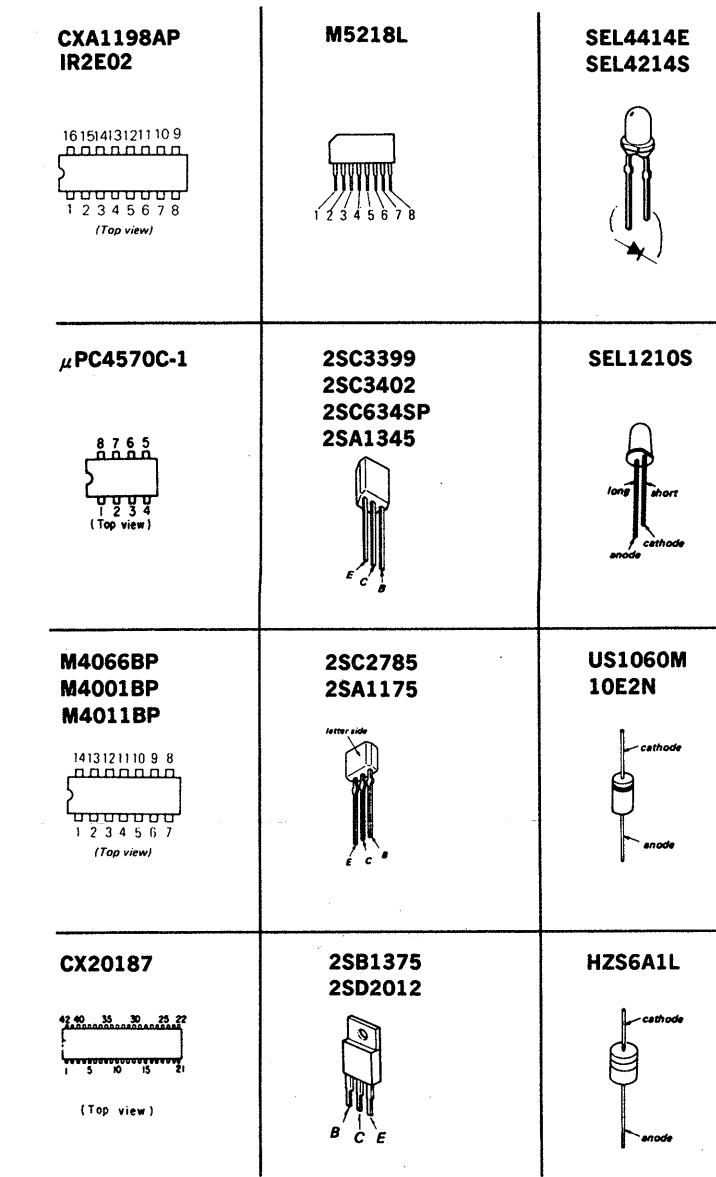

- Note:
- All capacitors are in μF unless otherwise noted. $\text{pF} = \mu\text{F} / 100$ or less are not indicated except for electrolytics and tantalums.
 - All resistors are in Ω and $1/4\text{W}$ or less unless otherwise specified.
 - Δ : internal component.
 - Switch

Ref. No.	Switch	Position
S301	DOLBY NR ON/OFF	OFF
S302	DOLBY NR TYPE B/C (TC-W300)	B-TYPE
S303	DECK A TAPE SELECT	TYPE-I
S304	DECK B TAPE SELECT	TYPE-I
S501	DUBBING SPEED	NDRMAL
S701	POWER	STANDBY
S901	DECK A MOTOR	OFF
S902	DECK A PLAY	OFF
S903	DECK B MOTOR	OFF
S904	DECK B PLAY	OFF
S905	DECK B REC	OFF
S910	VOLTAGE	220V

Note: The components identified by mark Δ or dotted line with mark Δ are critical for safety. Replace only with part number specified.

Note: Les composants identifiés par une marque Δ sont critiques pour la sécurité. Ne les remplacer que par une pièce portant le numéro spécifié.

- **B+**: B+Line
- **B-**: B-Line
- \square : adjustment for repair.
- Voltage and waveforms are dc with respect to ground under no-signal conditions. no mark: PLAY
< >: DUBBING SPEED (NORMAL)
[]: DUBBING SPEED (HIGH)
- \blacktriangleright : FWD \blacktriangleleft : REV \bullet : REC
- Voltages are taken with a VOM (50 $\text{k}\Omega/\text{V}$). Voltage variations may be noted due to normal production tolerances.
- Waveforms are taken with an oscilloscope. Voltage variations may be noted due to normal production tolerances.
- Signal path:
 - \square : PB (DECK A)
 - \square : PB (DECK B)
 - \square : REC (DECK B)

SECTION 5 EXPLODED VIEWS

NOTE:

- The mechanical parts with no reference number in the exploded views are not supplied.
- The construction parts of an assembled part are indicated with a collation number in the remark column.
- Items marked "★" are not stocked since they are seldom required for routine service. Some delay should be anticipated when ordering these items.

- Due to standardization, parts with part number suffix -XX and -X may be different from the parts specified in the components used on the set.
- Color Indication of Appearance Parts
Example:
(RED) ... KNOB, BALANCE (WHITE)
↑ Cabinet's Color ↑ Parts' Color

<p>The components identified by mark or dotted line with mark are critical for safety. Replace only with part number specified.</p>
<p>Les composants identifiés par une marque sont critiques pour la sécurité. Ne les remplacer que par une pièce portant le numéro spécifié.</p>

5-1. CASE, FRONT PANEL

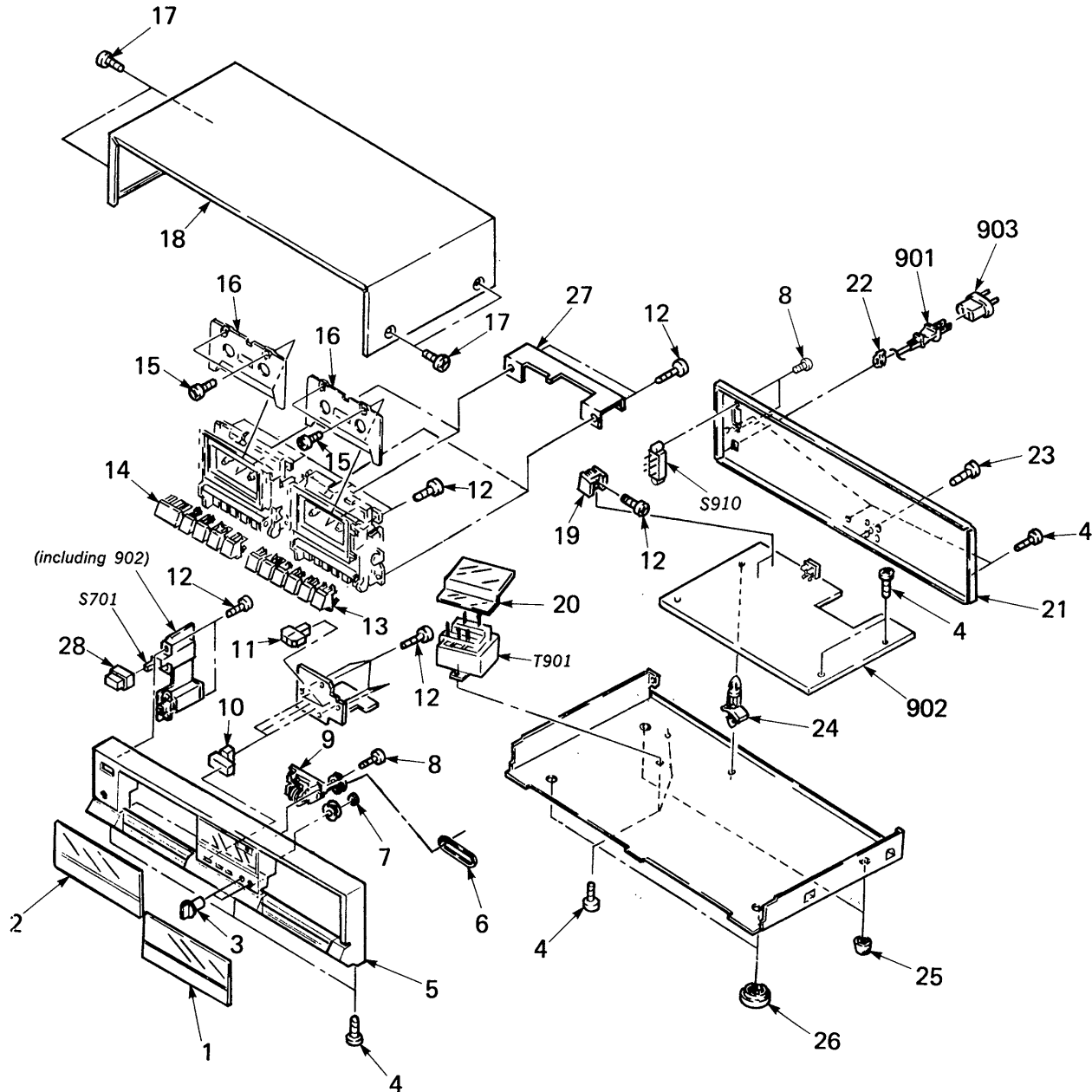

Ref.No	Part No.	Description	Remarks
1	X-3340-117-1	(TC-W300 ; AEP, UK, Canadian, E)....LID (B) ASSY, CASSETTE	
1	X-3340-118-1	(TC-W300 ; US)....LID (B) ASSY, CASSETTE	
1	X-3340-128-1	(TC-W190)....LID (B) ASSY, CASSETTE	
2	X-3340-115-1	(TC-W300 ; AEP, UK, Canadian, E)....LID (A) ASSY, CASSETTE	
2	X-3340-116-1	(TC-W300 ; US)....LID (A) ASSY, CASSETTE	
2	X-3340-127-1	(TC-W190)....LID (A) ASSY, CASSETTE	
3	3-346-380-01	KNOB (BALANCE, REC LEVEL) (BLK)	
3	3-346-380-21	(TC-W300)....KNOB (DALANCE, REC LEVEL) (RED)	
4	7-682-548-04	SCREW +BVTT 3X8 (S)	
5	X-3340-119-1	(TC-W300 ; AEP, UK, E)....PANEL ASSY, FRONT	
5	X-3340-120-1	(TC-W300 ; US, Canadian)....PANEL ASSY, FRONT	
5	X-3340-129-1	(TC-W190)....PANEL ASSY, FRONT	
6	3-305-524-00	BELT	
7	3-701-437-11	WASHER	
8	7-685-534-19	SCREW +BTP 2.6X8 TYPE2 N-S	
9	1-548-596-61	COUNTER, TAPE (MIDDLE TYPE)	
10	3-346-381-01	BUTTON	
11	3-346-379-01	KNOB (SLIDE)	
12	7-685-646-79	SCREW +BVTP 3X8 TYPE2 N-S	
13	3-346-385-01	BUTTON (BLOCK B)	
14	3-346-384-01	BUTTON (BLOCK A)	
15	7-685-133-19	SCREW +P 2.6X6 TYPE2 NON-SLIT	
16	4-914-974-01	PLATE, ORNAMENTAL, CASSETTE	
17	3-704-366-01	SCREW (CASE) (M3X8)	
18	*3-327-856-02	CASE	
19	*4-363-146-41	HEAT SINK, V.OUT	

Ref.No	Part No.	Description	Remarks
20	*3-327-855-01	COVER (TRANSFORMER)	
21	*3-346-346-01	(TC-W300 ; US, Canadian)....PANEL, BACK	
21	*3-346-346-11	(TC-W300 ; UK)....PANEL, BACK	
21	*3-346-346-21	(TC-W300 ; AEP1)....PANEL, BACK	
21	*3-346-346-31	(TC-W300 ; AEP2)....PANEL, BACK	
21	*3-346-346-41	(TC-W300 ; E)....PANEL, BACK	
21	*3-346-346-51	(TC-W190)....PANEL, BACK	
22	*3-703-244-00	(TC-W300 ; AEP, UK)....BUSHING (2104), CORD	
22	*3-703-571-00	(TC-W190, TC-W300 ; US, E, Canadian)....BUSHING (S) (4516), CORD	
23	7-621-849-00	SCREW, TAPPING	
24	*3-346-265-11	HOLDER, PC BOARD	
25	X-4864-303-0	FOOT ASSY	
26	X-3340-130-1	FOOT ASSY, ORNAMENTAL	
27	*3-346-376-01	REINFORCEMENT, MD	
28	4-917-460-01	KNOB, POWER	
901	Δ.1-551-188-XX	(TC-W300 ; E)....CORD,POWER	
901	Δ.1-551-506-XX	(TC-W300 ; US, Canadian/TC-W190)....CORD,POWER	
901	Δ.1-555-795-00	(TC-W300 ; AEP)....CORD, POWER, EULO PLUG	
901	Δ.1-556-035-00	(TC-W300 ; UK)....CORD, POWER	
902	*1-627-544-11	PC BOARD, AUDIO/SWITCH	
903	Δ.1-526-565-00	(TC-W300 ; E)....AC PLUG ADAPTOR	
S701	1-570-393-11	SWITCH, PUSH (1 KEY) (POWER)	
S910	Δ.1-570-307-11	SWITCH, VOLTAGE CHANGE	
T901	Δ.1-448-804-11	(TC-W300 ; US, Canadian/TC-W190)....TRANSFORMER, POWER	
T901	Δ.1-448-805-11	(TC-W300 ; AEP, UK)....TRANSFORMER, POWER	
T901	Δ.1-448-806-11	(TC-W300 ; E)....TRANSFORMER, POWER	

5-2. TAPE TRANSPORT MECHANISM-1

(DECK-A : TCM-YM47CW-61)
(DECK-B : TCM-YM47CW-60)

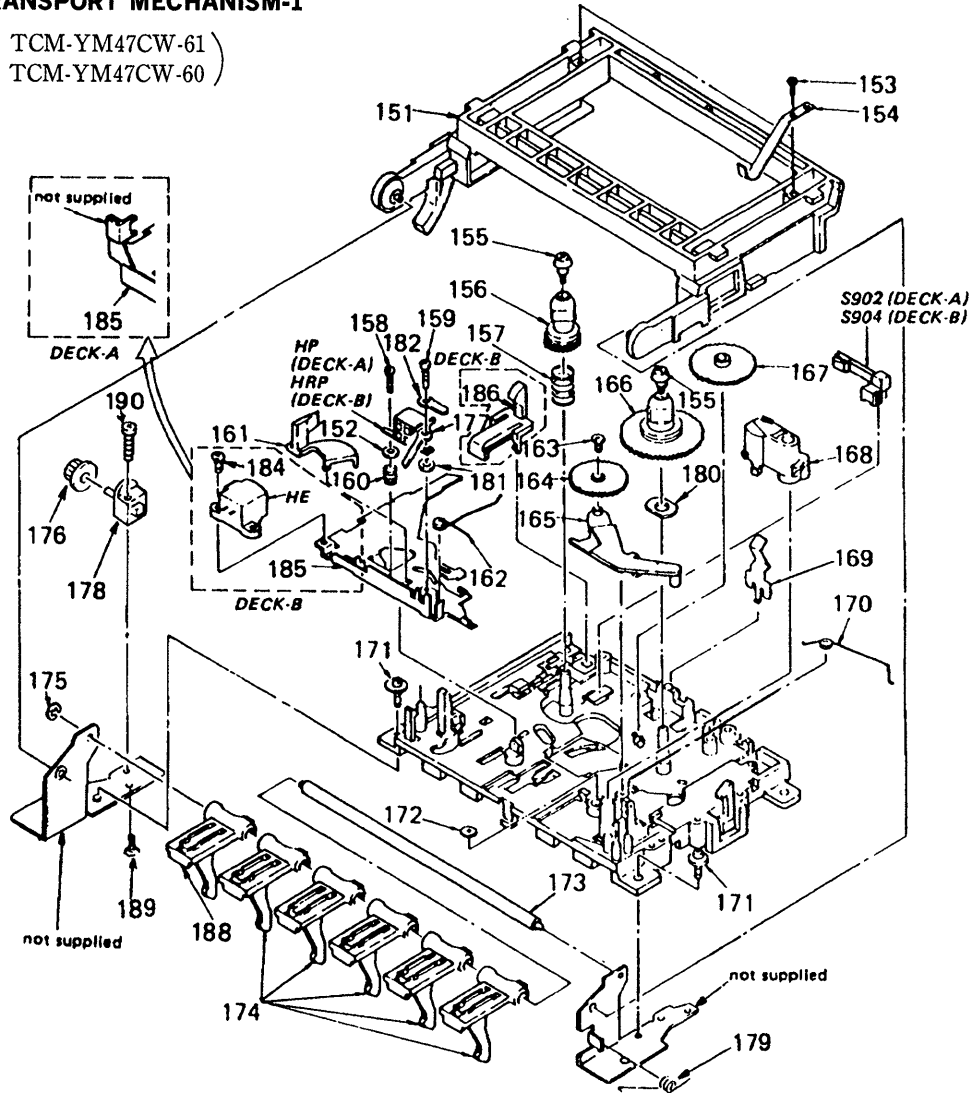

No.	Part No.	Description	Remarks	No.	Part No.	Description	Remarks
151	3-390-801-01	CASE, CASSETTE		173	*3-392-139-01	SHAFT	
152	3-390-823-01	WASHER, F		174	3-392-140-01	LEVER, BUTTON	
153	7-685-103-19	SCREW +P 2×5 TYPE2 NON-SLIT		175	7-624-104-04	STOP LING 2.0. TYPE-E	
154	4-894-951-01	KEEP PLATE		176	3-392-144-01	DAMPER, GEAR	
155	*3-390-803-01	SHAFT, PULLEY		177	3-390-817-01	LUG	
156	4-894-953-01	S REEL		178	*3-392-143-01	HOLDER, GEAR	
157	4-894-954-01	C SPRING		179	3-392-142-01	SPRING	
158	7-621-255-55	SCREW +P 2×8		180	3-390-820-01	SPRING, LEAF	
159	7-621-255-15	SCREW +P 2×3		181	3-390-821-01	SPACER	
160	4-894-955-01	C SPRING		182	3-390-819-01	LUG	
161	4-894-956-01	TAPE SENSOR		184	7-621-255-25	(DECK-B)SCREW +P 2×4	
162	3-390-804-01	SPRING, PINCH ARM		185	*4-895-015-01	(DECK-A)HEAD BASE	
163	4-894-960-01	BUSH		185	4-894-957-01	(DECK-B)HEAD BASE B	
164	4-894-951-01	IDLER GEAR		186	4-894-958-01	(DECK-B)INTERLOCK ARM	
165	4-894-962-01	IDLER ARM		188	3-392-147-01	(DECK-B) LEVER (R) , BUTTON	
166	4-894-963-01	T REEL ASSY		189	7-685-234-14	SCREW +KTP 2.6×8 TYPE2 NON-SLIT	
167	4-894-964-01	F GEAR		190	7-685-856-01	SCREW +BVT 2×12 (S)	
168	3-390-805-01	ROLLER ASSY, PINCH		HE	1-543-261-11	(DECK-B)HEAD.ERASE (886-01-24)	
169	4-894-966-01	SPRING		HP	1-543-424-21	(DECK-A)HEAD, MAGNETIC (PB)	
170	4-894-967-01	SPRING		HRP	1-543-424-21	(DECK-B)HEAD, MAGNETIC (REC/PB)	
171	7-621-770-67	SCREW +B 2.6×6		S902	1-570-430-11	(DECK-A)SWITCH, LEAF (PLAY)	
172	4-894-969-01	N WASHER		S904	1-570-430-11	(DECK-B)SWITCH, LEAF (PLAY)	

5-3. TAPE TRANSPORT MECHANISM-2

(DECK-A : TCM-YM47CW-61)
 (DECK-B : TCM-YM47CW-60)

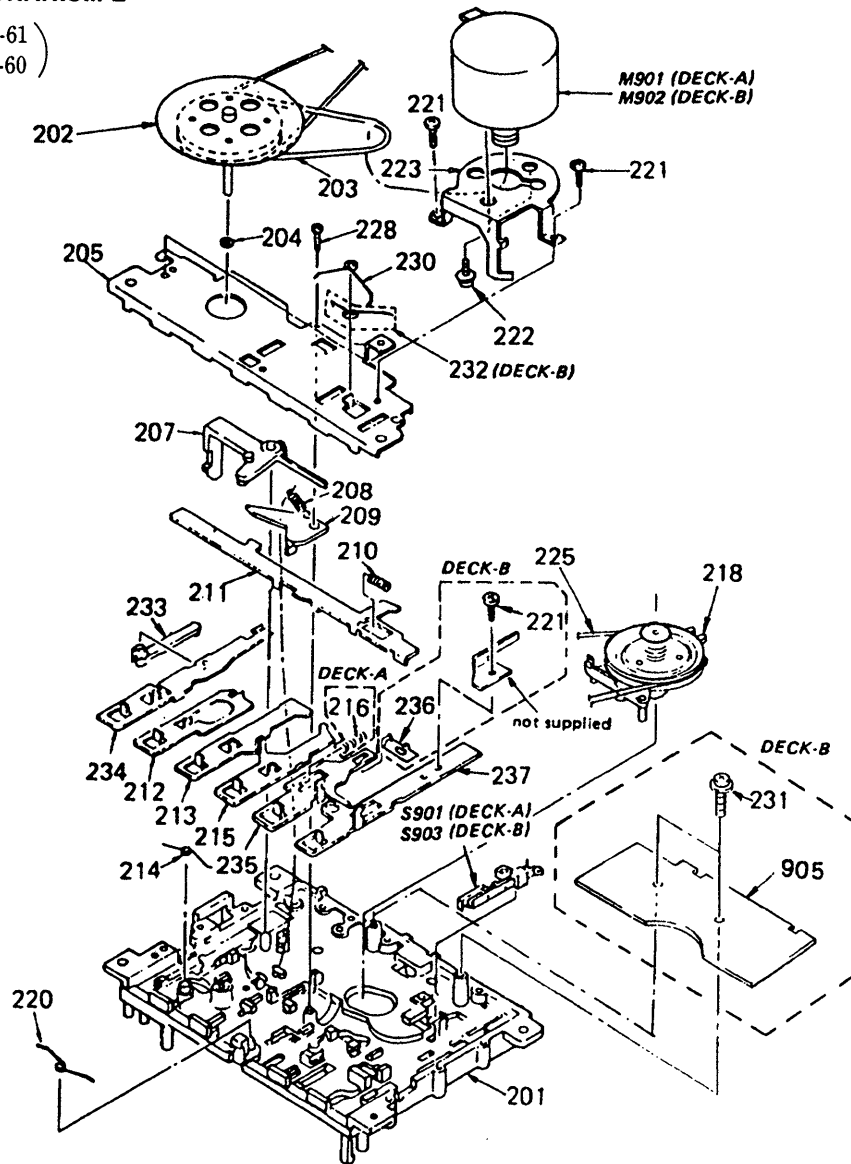

No.	Part No.	Description	Remarks	No.	Part No.	Description	Remarks
201	4-894-968-01	CHASSIS ASSY		225	3-561-892-00	BELT, SQUARE	
202	3-390-806-11	FW ASSY		228	3-390-822-01	BUSHING (C)	
203	3-390-807-01	BELT		229	7-685-133-19	SCREW +P 2.6×6 TYPE1	
204	4-894-976-01	P WASHER		230	4-894-978-01	SPRING	
205	*4-894-977-01	BACK PLATE		231	7-687-233-11	SCREW +PTPH 2.6×6	
207	*4-894-980-01	EJECT ARM		232	4-894-979-01	DECK-B)SPRING	
208	3-390-809-01	SPRING		233	4-894-985-01	PAUSE ARM	
209	4-894-982-01	S ARM		234	4-894-986-01	PAUSE LEVER	
210	4-894-983-01	C SPRING		235	3-390-810-01	LEVER, PLAY	
211	4-894-984-01	FUNCTION LEVER		236	3-390-811-01	DECK-B)LEVER, REC STOP	
212	4-894-987-01	S, E LEVER		237	*4-894-994-01	REC LEVER	
213	*4-894-988-01	PF LEVER W		905	*1-628-420-21	PC BOARD, MAIN (A)	
214	4-894-969-01	SPRING		M901	X-3390-801-1	DECK-A)MOTOR ASSY	
215	*4-894-990-01	REW LEVER		M902	X-3390-801-1	DECK-B)MOTOR ASSY	
216	3-390-827-01	DECK-A)SPRING		S901	1-570-715-11	DECK-A)SWITCH, LEAF (MOTOR)	
218	4-894-997-01	POWER ARM ASSY		S903	1-570-715-11	DECK-B)SWITCH, LEAF (MOTOR)	
220	4-894-999-01	SPRING					
221	7-621-255-25	SCREW +P 2×4					
222	7-628-253-90	SCREW +PS 2.6×4					
223	*3-390-814-01	BRACKET, MOTOR					

SECTION 6 ELECTRICAL PARTS LIST

NOTE:

- Due to standardization, replacements in the parts list may be different from the parts specified in the diagrams or the components used on the set.
- Items marked "★" are not stocked since they are seldom required for routine service. Some delay should be anticipated when ordering these items.
- If there are two or more same circuits in a set such as a stereophonic machine, only typical circuit parts may be indicated and capacitors and resistors in other same circuits may be omitted.

CAPACITORS:MF: μ F, PF: μ PF.**RESISTORS**

- All resistors are in ohms.
- F: nonflammable

COILS

- MMH: mH, UH: μ H

SEMICONDUCTORSIn each case, U: μ , for example:UA....: μ A..., UPA....: μ PA...,
UPC....: μ PC, UPD....: μ PD...

The components identified by mark Δ or dotted line with mark Δ are critical for safety. Replace only with part number specified.

Les composants identifiés par une marque Δ sont critiques pour la sécurité. Ne les remplacer que par une pièce portant le numéro spécifié.

Ref.No	Part No.	Description							
901	Δ .1-551-188-XX	(TC-W300 ; E)....CORD, POWER							
901	Δ .1-551-506-XX	(TC-W300 ; US, Canadian/TC-W190)CORD, POWER							
901	Δ .1-555-795-00	(TC-W300 ; AEP)....CORD, POWER, EULO PLUG							
901	Δ .1-556-035-00	(TC-W300 ; UK)....CORD, POWER							
902	* 1-627-544-11	PC BOARD, AUDIO/SWITCH							
903	Δ .1-526-565-00	(TC-W300 ; E)....AC PLUG ADAPTOR							
905	* 1-628-420-21	PC BOARD, MAIN (A)							
CAPACITOR									
C101	1-162-288-31	CERAMIC	330PF	10%	50V				
C102	1-136-157-00	FILM	0.022MF	5%	50V				
C103	1-124-767-00	ELECT	2.2MF	20%	50V				
C106	1-162-289-31	CERAMIC	390PF	10%	50V				
C107	1-136-157-00	FILM	0.022MF	5%	50V				
C108	1-124-767-00	ELECT	2.2MF	20%	50V				
C111	1-130-479-00	MYLAR	0.0047MF	5%	50V				
C112	1-162-289-31	CERAMIC	390PF	10%	50V				
C120	1-123-875-11	ELECT	10MF	20%	50V				
C121	1-123-875-11	(TC-W300)....ELECT	10MF	20%	50V				
C122	1-130-479-00	(TC-W300)....MYLAR	0.0047MF	5%	50V				
C123	1-136-173-00	(TC-W300)....FILM	0.47MF	5%	50V				
C123	1-131-587-11	(TC-W190)TANTALUM	0.68MF	10%	35V				
C124	1-136-167-00	(TC-W300)....FILM	0.15MF	5%	50V				
C125	1-136-155-00	(TC-W300)....FILM	0.015MF	5%	50V				
C126	1-136-169-00	(TC-W300)....FILM	0.22MF	5%	50V				
C127	1-136-163-00	(TC-W300)....FILM	0.068MF	5%	50V				
C128	1-136-161-00	(TC-W300)....FILM	0.047MF	5%	50V				
C129	1-130-481-00	(TC-W300)....MYLAR	0.0068MF	5%	50V				
C130	1-136-153-00	(TC-W300)....FILM	0.01MF	5%	50V				
C131	1-123-875-11	ELECT	10MF	20%	50V				
C132	1-124-925-11	ELECT	2.2MF	20%	50V				
C133	1-124-902-00	ELECT	0.47MF	20%	50V				
C134	1-123-875-11	ELECT	10MF	20%	50V				
C135	1-123-875-11	ELECT	10MF	20%	50V				
C136	1-162-284-31	CERAMIC	150PF	10%	50V				
C137	1-136-273-91	FILM	75PF	5%	630V				
C138	1-136-440-11	FILM	39PF	5%	630V				
C141	1-161-375-00	(TC-W300)....CERAMIC	0.0022MF	20%	16V				
C141	1-123-875-11	(TC-W190)....ELECT	10MF	20%	50V				
C151	1-124-499-11	ELECT	1MF	20%	50V				
C152	1-124-925-11	ELECT	2.2MF	20%	50V				
C201	1-162-288-31	CERAMIC	330PF	10%	50V				
C202	1-136-157-00	FILM	0.022MF	5%	50V				
C203	1-124-767-00	ELECT	2.2MF	20%	50V				
C206	1-162-289-31	CERAMIC	390PF	10%	50V				
C207	1-136-157-00	FILM	0.022MF	5%	50V				
C208	1-124-767-00	ELECT	2.2MF	20%	50V				
C211	1-130-479-00	MYLAR	0.0047MF	5%	50V				
C212	1-162-289-31	CERAMIC	390PF	10%	50V				
C220	1-123-875-11	ELECT	10MF	20%	50V				
C221	1-123-875-11	(TC-W300)....ELECT	10MF	20%	50V				
C222	1-130-479-00	(TC-W300)....MYLAR	0.0047MF	5%	50V				
C223	1-136-173-00	(TC-W300)....FILM	0.47MF	5%	50V				
C223	1-131-587-11	(TC-W190)TANTALUM	0.68MF	10%	35V				
C224	1-136-167-00	(TC-W300)....FILM	0.15MF	5%	50V				
C225	1-136-155-00	(TC-W300)....FILM	0.015MF	5%	50V				
C226	1-136-169-00	(TC-W300)....FILM	0.22MF	5%	50V				
C227	1-136-163-00	(TC-W300)....FILM	0.068MF	5%	50V				
C228	1-136-161-00	(TC-W300)....FILM	0.047MF	5%	50V				
C229	1-130-481-00	(TC-W300)....MYLAR	0.0068MF	5%	50V				
C230	1-136-153-00	(TC-W300)....FILM	0.01MF	5%	50V				
C231	1-123-875-11	ELECT	10MF	20%	50V				
C232	1-124-925-11	ELECT	2.2MF	20%	50V				
C233	1-124-902-00	ELECT	0.47MF	20%	50V				
C234	1-123-875-11	ELECT	10MF	20%	50V				
C235	1-123-875-11	ELECT	10MF	20%	50V				
C236	1-162-284-31	CERAMIC	150PF	10%	50V				
C237	1-136-273-91	FILM	75PF	5%	630V				
C238	1-136-440-11	FILM	39PF	5%	630V				
C241	1-161-375-00	(TC-W300)....CERAMIC	0.0022MF	20%	16V				
C251	1-124-499-11	ELECT	1MF	20%	50V				
C252	1-124-925-11	ELECT	2.2MF	20%	50V				
C252	1-123-875-11	(TC-W190)....ELECT	10MF	20%	50V				
C301	1-124-443-00	ELECT	100MF	20%	10V				
C302	1-124-443-00	ELECT	100MF	20%	10V				
C303	1-124-443-00	ELECT	100MF	20%	10V				
C304	1-124-443-00	ELECT	100MF	20%	10V				
C311	1-126-176-11	ELECT	220MF	20%	10V				
C312	1-126-176-11	ELECT	220MF	20%	10V				
C316	1-123-875-11	ELECT	10MF	20%	50V				
C321	1-124-902-00	ELECT	0.47MF	20%	50V				
C322	1-124-925-11	ELECT	2.2MF	20%	50V				
C323	1-130-478-00	MYLAR	0.0039MF	5%	50V				
C324	1-130-478-00	MYLAR	0.0039MF	5%	50V				
C325	1-130-482-00	MYLAR	0.0082MF	5%	50V				
C326	1-136-562-11	FILM	0.0082MF	5%	630V				
C327	1-124-925-11	ELECT	2.2MF	20%	50V				
C501	1-123-875-11	ELECT	10MF	20%	50V				
C502	1-123-875-11	ELECT	10MF	20%	50V				
C503	1-124-499-11	ELECT	1MF	20%	50V				
C701	1-124-360-00	ELECT	1000MF	20%	16V				
C702	1-124-360-00	ELECT	1000MF	20%	16V				
C703	1-126-105-11	ELECT	1000MF	20%	35V				
C704	1-124-120-11	ELECT	220MF	20%	16V				
C705	1-124-120-11	ELECT	220MF	20%	16V				
C706	1-123-875-11	ELECT	10MF	20%	50V				
C707	1-124-443-00	ELECT	100MF	20%	10V				
C708	1-124-443-00	ELECT	100MF	20%	10V				
C709	1-162-288-31	CERAMIC	330PF	10%	50V				
C710	1-162-288-31	CERAMIC	330PF	10%	50V				
CN503	* 1-566-659-11	CONNECTOR, HINGE (SOCKET) 18P							
CN504	* 1-566-827-11	SOCKET, CONNECTOR 12P							
CNP301	* 1-564-705-11	PIN, CONNECTOR (SMALL TYPE) 3P							

Ref.No	Part No.	Description
CNP302	*1-564-705-11	PIN, CONNECTOR (SMALL TYPE) 3P
CNP303	*1-564-704-11	PIN, CONNECTOR (SMALL TYPE) 2P
CNP503	*1-566-660-11	CONNECTOR, HINGE (PLUG) 18P
CNP504	*1-566-826-11	PLUG, CONNECTOR 12P
CNP505	*1-564-505-11	PLUG, CONNECTOR 2P
CNP801	*1-564-499-11	(DECK-A)....PIN, CONNECTOR 6P
CNP802	*1-564-500-11	(DECK-B)....PIN, CONNECTOR 7P
CNP803	*1-564-497-11	PIN, CONNECTOR 4P
CT301	1-141-225-00	CAP, TUNING, TRIMMER
D101	8-719-304-37	DIODE SEL4414E
D102	8-719-304-37	DIODE SEL4414E
D103	8-719-304-37	DIODE SEL4414E
D104	8-719-304-37	DIODE SEL4414E
D105	8-719-304-32	DIODE SEL4214S
D106	8-719-304-32	DIODE SEL4214S
D107	8-719-304-32	DIODE SEL4214S
D201	8-719-304-37	DIODE SEL4414E
D202	8-719-304-37	DIODE SEL4414E
D203	8-719-304-37	DIODE SEL4414E
D204	8-719-304-37	DIODE SEL4414E
D205	8-719-304-32	DIODE SEL4214S
D206	8-719-304-32	DIODE SEL4214S
D207	8-719-304-32	DIODE SEL4214S
D301	8-719-000-26	DIODE US1060M
D302	8-719-000-26	DIODE US1060M
D303	8-719-000-26	DIODE US1060M
D304	8-719-000-26	DIODE US1060M
D305	8-719-000-26	DIODE US1060M
D501	8-719-000-26	DIODE US1060M
D502	8-719-000-26	DIODE US1060M
D503	8-719-000-26	DIODE US1060M
D504	8-719-000-26	DIODE US1060M
D505	8-719-000-26	DIODE US1060M
D506	8-719-000-26	DIODE US1060M
D507	8-719-000-26	DIODE US1060M
D511	8-719-302-45	DIODE SEL1210S
D512	8-719-302-45	(TC-W300)....DIODE SEL1210S
D513	8-719-302-45	DIODE SEL1210S
D701	8-719-200-77	DIODE 10E2N
D702	8-719-200-77	DIODE 10E2N
D703	8-719-200-77	DIODE 10E2N
D704	8-719-200-77	DIODE 10E2N
D705	8-719-933-33	DIODE HZS6A1L
IC101	8-759-912-79	IC IR2E02
IC201	8-759-912-79	IC IR2E02
IC301	8-759-111-44	IC UPC4570C-1
IC302	8-759-111-44	IC UPC4570C-1
IC303	8-759-601-43	IC M4066BP
IC304	8-752-018-70	(TC-W300)....IC CX20187
IC304	8-752-031-67	(TC-W190)....IC CXA1100P
IC305	8-752-033-61	IC CXA1198AP
IC306	8-759-600-02	IC M5218L
IC307	8-759-601-02	(TC-W190)....IC M5218P
IC501	8-759-601-06	IC M4001BP
IC502	8-759-601-10	IC M4011BP
J301	1-565-258-11	JACK, PIN 4P (LINE IN/OUT)
J302	1-507-982-11	JACK (LARGE TYPE) (HEADPHONE)
L101	1-410-780-11	INDUCTOR 27MMH
L201	1-410-780-11	INDUCTOR 27MMH
LPF101	1-236-087-11	FILTER, LOW PASS
LPF201	1-236-087-11	FILTER, LOW PASS
Q101	8-729-806-38	TRANSISTOR 2SC3399
Q102	8-729-178-54	TRANSISTOR 2SC2785
Q103	8-729-178-54	TRANSISTOR 2SC2785

Ref.No	Part No.	Description
Q201	8-729-806-38	TRANSISTOR 2SC3399
Q202	8-729-178-54	TRANSISTOR 2SC2785
Q203	8-729-178-54	TRANSISTOR 2SC2785
Q301	8-729-806-38	TRANSISTOR 2SC3399
Q302	8-729-806-38	TRANSISTOR 2SC3399
Q303	8-729-806-38	TRANSISTOR 2SC3399
Q304	8-729-806-20	TRANSISTOR 2SA1345
Q305	8-729-600-27	TRANSISTOR 2SC634SP
Q306	8-729-600-27	TRANSISTOR 2SC634SP
Q307	8-729-600-27	TRANSISTOR 2SC634SP
Q308	8-729-806-28	TRANSISTOR 2SC3402
Q501	8-729-806-38	TRANSISTOR 2SC3399
Q502	8-729-806-20	TRANSISTOR 2SA1345
Q503	8-729-806-38	TRANSISTOR 2SC3399
Q504	8-729-806-38	TRANSISTOR 2SC3399
Q505	8-729-806-20	TRANSISTOR 2SA1345
Q506	8-729-806-20	TRANSISTOR 2SA1345
Q507	8-729-178-54	TRANSISTOR 2SC2785
Q701	8-729-178-54	TRANSISTOR 2SC2785
Q702	8-729-178-54	TRANSISTOR 2SC2785
Q703	8-729-209-60	TRANSISTOR 2SB1375
Q704	8-729-117-54	TRANSISTOR 2SA1175
Q705	8-729-117-54	TRANSISTOR 2SA1175
Q706	8-729-209-15	TRANSISTOR 2SD2012

RESISTOR

Ref.No	Part No.	Description	Value	Tolerance	Power
R101	1-247-889-00	CARBON	270K	5%	1/4W
R102	1-249-404-00	(TC-W300) ... CARBON	82	5%	1/4W
R102	1-249-403-11	(TC-W190) ... CARBON	68	5%	1/4W
R103	1-249-426-11	CARBON	5.6K	5%	1/4W
R104	1-247-881-00	CARBON	120K	5%	1/4W
R106	1-247-889-00	CARBON	270K	5%	1/4W
R107	1-249-404-00	(TC-W300) ... CARBON	82	5%	1/4W
R107	1-249-403-00	(TC-W190) ... CARBON	68	5%	1/4W
R108	1-249-426-11	CARBON	5.6K	5%	1/4W
R109	1-247-881-00	CARBON	120K	5%	1/4W
R110	1-249-417-11	CARBON	1K	5%	1/4W
R111	1-247-856-00	(TC-W300) ... CARBON	11K	5%	1/4W
R111	1-249-430-11	(TC-W190) ... CARBON	12K	5%	1/4W
R112	1-249-431-11	CARBON	15K	5%	1/4W
R113	1-247-887-00	CARBON	220K	5%	1/4W
R120	1-249-433-11	CARBON	22K	5%	1/4W
R121	1-249-423-11	(TC-W300) ... CARBON	3.3K	5%	1/4W
R122	1-249-428-11	(TC-W300) ... CARBON	8.2K	5%	1/4W
R123	1-247-840-00	(TC-W300) ... CARBON	2.4K	5%	1/4W
R124	1-249-425-11	(TC-W300) ... CARBON	4.7K	5%	1/4W
R125	1-247-822-11	(TC-W300) ... CARBON	430	5%	1/4W
R126	1-249-427-11	(TC-W300) ... CARBON	6.8K	5%	1/4W
R127	1-249-415-11	(TC-W300) ... CARBON	680	5%	1/4W
R128	1-249-421-11	CARBON	2.2K	5%	1/4W
R129	1-249-425-11	CARBON	4.7K	5%	1/4W
R130	1-249-417-11	CARBON	1K	5%	1/4W
R131	1-249-429-11	CARBON	10K	5%	1/4W
R132	1-249-427-11	CARBON	6.8K	5%	1/4W
R133	1-249-422-11	CARBON	2.7K	5%	1/4W
R134	1-249-425-11	CARBON	4.7K	5%	1/4W
R135	1-249-437-11	CARBON	47K	5%	1/4W
R136	1-249-430-11	CARBON	12K	5%	1/4W
R144	1-249-429-11	CARBON	10K	5%	1/4W

Ref.No	Part No.	Description							
R145	1-249-433-11	CARBON	22K	5%	1/4W				
R146	1-249-431-11	CARBON	15K	5%	1/4W				
R147	1-249-409-11	CARBON	220	5%	1/4W				
R151	1-249-429-11	CARBON	10K	5%	1/4W				
R152	1-249-423-11	(TC-W300)CARBON	3.3K	5%	1/4W				
R152	1-249-421-11	(TC-W190)CARBON	2.2K	5%	1/4W				
R153	1-249-425-11	CARBON	4.7K	5%	1/4W				
R154	1-249-425-11	CARBON	4.7K	5%	1/4W				
R155	1-249-441-11	CARBON	100K	5%	1/4W				
R156	1-249-441-11	CARBON	100K	5%	1/4W				
R157	1-249-433-11	CARBON	22K	5%	1/4W				
R161	1-249-441-11	(TC-W190)CARBON	100K	5%	1/4W				
R162	1-249-417-11	(TC-W190)CARBON	1K	5%	1/4W				
R163	1-249-429-11	(TC-W190)CARBON	10K	5%	1/4W				
R164	1-249-425-11	(TC-W190)CARBON	4.7K	5%	1/4W				
R165	1-249-231-11	(TC-W190)CARBON	3.3K	5%	1/4W				
R166	1-249-428-11	(TC-W190)CARBON	8.2K	5%	1/4W				
R201	1-247-889-00	CARBON	270K	5%	1/4W				
R202	1-249-404-00	(TC-W300)CARBON	82	5%	1/4W				
R202	1-249-403-11	(TC-W190)CARBON	68	5%	1/4W				
R203	1-249-426-11	CARBON	5.6K	5%	1/4W				
R204	1-247-881-00	CARBON	120K	5%	1/4W				
R206	1-247-889-00	CARBON	270K	5%	1/4W				
R207	1-249-404-00	(TC-W300)CARBON	82	5%	1/4W				
R207	1-249-403-11	(TC-W190)CARBON	68	5%	1/4W				
R208	1-249-426-11	CARBON	5.6K	5%	1/4W				
R209	1-247-881-00	CARBON	120K	5%	1/4W				
R210	1-249-417-11	CARBON	1K	5%	1/4W				
R211	1-247-856-00	(TC-W300)CARBON	11K	5%	1/4W				
R211	1-249-430-11	(TC-W190)CARBON	68	5%	1/4W				
R212	1-249-431-11	CARBON	15K	5%	1/4W				
R213	1-247-887-00	CARBON	220K	5%	1/4W				
R220	1-249-433-11	CARBON	22K	5%	1/4W				
R221	1-249-423-11	(TC-W300)CARBON	3.3K	5%	1/4W				
R222	1-249-428-11	(TC-W300)CARBON	8.2K	5%	1/4W				
R223	1-247-840-00	(TC-W300)CARBON	2.4K	5%	1/4W				
R224	1-249-425-11	(TC-W300)CARBON	4.7K	5%	1/4W				
R225	1-247-822-11	(TC-W300)CARBON	430	5%	1/4W				
R226	1-249-427-11	(TC-W300)CARBON	6.8K	5%	1/4W				
R227	1-249-415-11	(TC-W300)CARBON	680	5%	1/4W				
R228	1-249-421-11	CARBON	2.2K	5%	1/4W				
R229	1-249-425-11	CARBON	4.7K	5%	1/4W				
R230	1-249-417-11	CARBON	1K	5%	1/4W				
R231	1-249-429-11	CARBON	10K	5%	1/4W				
R232	1-249-427-11	CARBON	6.8K	5%	1/4W				
R233	1-249-422-11	CARBON	2.7K	5%	1/4W				
R234	1-249-425-11	CARBON	4.7K	5%	1/4W				
R235	1-249-437-11	CARBON	47K	5%	1/4W				
R236	1-249-430-11	CARBON	12K	5%	1/4W				
R244	1-249-429-11	CARBON	10K	5%	1/4W				
R245	1-249-433-11	CARBON	22K	5%	1/4W				
R246	1-249-431-11	CARBON	15K	5%	1/4W				
R247	1-249-409-11	CARBON	220	5%	1/4W				
R251	1-249-429-11	CARBON	10K	5%	1/4W				
R252	1-249-421-11	(TC-W190)CARBON	2.2K	5%	1/4W				
R252	1-249-423-11	(TC-W300)CARBON	3.3K	5%	1/4W				
R253	1-249-425-11	CARBON	4.7K	5%	1/4W				
R254	1-249-425-11	CARBON	4.7K	5%	1/4W				
R255	1-249-441-11	CARBON	100K	5%	1/4W				
R256	1-249-441-11	CARBON	100K	5%	1/4W				
R257	1-249-433-11	CARBON	22K	5%	1/4W				
R261	1-249-441-11	(TC-W190)CARBON	100K	5%	1/4W				
R262	1-249-417-11	(TC-W190)CARBON	1K	5%	1/4W				
R263	1-249-429-11	(TC-W190)CARBON	10K	5%	1/4W				
R264	1-249-425-11	(TC-W190)CARBON	4.7K	5%	1/4W				
R265	1-249-423-11	(TC-W190)CARBON	3.3K	5%	1/4W				
R266	1-249-428-11	(TC-W190)CARBON	8.2K	5%	1/4W				
R301	1-249-409-11	CARBON	220	5%	1/4W				
R302	1-249-409-11	CARBON	220	5%	1/4W				
R303	1-249-409-11	CARBON	220	5%	1/4W				
R304	1-249-409-11	CARBON	220	5%	1/4W				
R305	1-247-733-11	(TC-W300)CARBON	33	5%	1/2W				
R305	1-247-739-11	(TC-W190)CARBON	100	5%	1/2W				
R306	1-247-733-11	(TC-W300)CARBON	33	5%	1/2W				
R306	1-247-739-11	(TC-W190)CARBON	100	5%	1/2W				
R307	1-215-460-00	(TC-W190)METAL	43K	5%	1/6W				
R307	1-215-469-00	(TC-W300)METAL	100K	1%	1/6W				
R310	1-247-864-11	CARBON	24K	5%	1/4W				
R311	1-249-439-11	CARBON	68K	5%	1/4W				
R312	1-249-439-11	CARBON	68K	5%	1/4W				
R313	1-247-883-00	CARBON	150K	5%	1/4W				
R314	1-249-441-11	CARBON	100K	5%	1/4W				
R315	1-249-436-11	CARBON	39K	5%	1/4W				
R316	1-247-872-11	CARBON	51K	5%	1/4W				
R317	1-247-887-00	CARBON	220K	5%	1/4W				
R318	1-249-440-11	CARBON	82K	5%	1/4W				
R319	1-249-441-11	CARBON	100K	5%	1/4W				
R320	1-249-440-11	CARBON	82K	5%	1/4W				
R321	1-247-872-11	CARBON	51K	5%	1/4W				
R322	1-249-439-11	CARBON	68K	5%	1/4W				
R323	1-247-887-00	CARBON	220K	5%	1/4W				
R324	1-247-883-00	CARBON	150K	5%	1/4W				
R325	1-249-438-11	CARBON	56K	5%	1/4W				
R326	1-249-436-11	CARBON	39K	5%	1/4W				
R327	1-247-874-11	CARBON	62K	5%	1/4W				
R328	1-247-876-11	CARBON	75K	5%	1/4W				
R329	1-247-881-00	CARBON	120K	5%	1/4W				
R330	1-249-439-11	CARBON	68K	5%	1/4W				
R331	1-249-437-11	CARBON	47K	5%	1/4W				
R332	1-249-434-11	CARBON	27K	5%	1/4W				
R333	1-249-436-11	CARBON	39K	5%	1/4W				
R334	1-249-434-11	CARBON	27K	5%	1/4W				
R335	1-249-441-11	CARBON	100K	5%	1/4W				
R336	1-249-441-11	CARBON	100K	5%	1/4W				
R337	1-249-435-11	CARBON	33K	5%	1/4W				
R338	1-249-434-11	CARBON	27K	5%	1/4W				
R339	1-249-438-11	CARBON	56K	5%	1/4W				
R340	1-249-437-11	CARBON	47K	5%	1/4W				
R341	1-249-441-11	CARBON	100K	5%	1/4W				

Ref.No	Part No.	Description			
R342	1-247-881-00	CARBON	120K	5%	1/4W
R343	1-249-434-11	CARBON	27K	5%	1/4W
R344	1-249-433-11	CARBON	22K	5%	1/4W
R345	1-249-439-11	CARBON	68K	5%	1/4W
R346	1-247-872-11	CARBON	51K	5%	1/4W
R347	1-249-437-11	CARBON	47K	5%	1/4W
R348	1-249-441-11	CARBON	100K	5%	1/4W
R349	1-249-441-11	CARBON	100K	5%	1/4W
R351	1-249-429-11	CARBON	10K	5%	1/4W
R352	1-249-417-11	CARBON	1K	5%	1/4W
R353	1-249-433-11	CARBON	22K	5%	1/4W
R354	1-249-433-11	CARBON	22K	5%	1/4W
R355	1-249-393-11	CARBON	10	5%	1/4W
R356	1-249-425-11	CARBON	4.7K	5%	1/4W
R357	1-249-429-11	CARBON	10K	5%	1/4W
R358	1-249-424-11	CARBON	3.9K	5%	1/4W
R359	1-249-413-11	CARBON	470	5%	1/4W
R361	1-249-404-00	CARBON	82	5%	1/4W
R362	1-249-433-11	CARBON	22K	5%	1/4W
R363	1-249-433-11	(TC-W300) ... CARBON	22K	5%	1/4W
R364	1-249-437-11	CARBON	47K	5%	1/4W
R365	1-249-437-11	(TC-W300) ... CARBON	47K	5%	1/4W
R501	1-249-433-11	CARBON	22K	5%	1/4W
R502	1-249-433-11	CARBON	22K	5%	1/4W
R503	1-249-437-11	CARBON	47K	5%	1/4W
R504	1-249-437-11	CARBON	47K	5%	1/4W
R505	1-249-429-11	CARBON	10K	5%	1/4W
R506	1-249-435-11	CARBON	33K	5%	1/4W
R507	1-249-431-11	CARBON	15K	5%	1/4W
R508	1-249-437-11	CARBON	47K	5%	1/4W
R511	1-249-409-11	CARBON	220	5%	1/4W
R512	1-249-433-11	CARBON	22K	5%	1/4W
R513	1-249-433-11	CARBON	22K	5%	1/4W
R515	1-249-433-11	CARBON	22K	5%	1/4W
R521	1-249-421-11	CARBON	2.2K	5%	1/4W
R522	1-249-407-11	CARBON	150	5%	1/4W
R523	1-249-421-11	CARBON	2.2K	5%	1/4W
R524	1-249-407-11	CARBON	150	5%	1/4W
R531	1-249-413-11	CARBON	470	5%	1/4W
R532	1-249-413-11	CARBON	470	5%	1/4W
R533	1-249-413-11	CARBON	470	5%	1/4W
R701	1-249-421-11	CARBON	2.2K	5%	1/4W
R702	1-249-421-11	CARBON	2.2K	5%	1/4W
R703	1-249-421-11	CARBON	2.2K	5%	1/4W
R704	1-249-421-11	CARBON	2.2K	5%	1/4W
R705	1-249-421-11	CARBON	2.2K	5%	1/4W
R706	1-249-409-11	CARBON	220	5%	1/4W
R707	1-249-423-11	CARBON	3.3K	5%	1/4W
R708	1-249-423-11	CARBON	3.3K	5%	1/4W
R709	1-249-424-11	CARBON	3.9K	5%	1/4W
RV101	1-228-994-00	RES, ADJ, CARBON 10K			
RV102	1-228-994-00	RES, ADJ, CARBON 10K			
RV103	1-228-994-00	RES, ADJ, CARBON 10K			
RV201	1-228-994-00	RES, ADJ, CARBON 10K			
RV202	1-228-994-00	RES, ADJ, CARBON 10K			
RV203	1-228-994-00	RES, ADJ, CARBON 10K			
RV301	1-238-261-11	RES, VAR, CARBON 50K/50K (BALANCE)			
RV302	1-238-260-11	RES, VAR, CARBON 20K/20K (REC LEVEL)			
RV501	1-228-990-00	RES, ADJ, CARBON 1K			
RV502	1-228-990-00	RES, ADJ, CARBON 1K			
RV503	1-228-990-00	RES, ADJ, CARBON 1K			
RV504	1-228-990-00	RES, ADJ, CARBON 1K			
RY301	1-515-614-11	RELAY			

Ref.No	Part No.	Description
S301	1-571-510-11	SWITCH, PUSH (1 KEY) (DOLBY NR ON/OFF)
S302	1-571-510-11	(TC-W300)... SWITCH, PUSH (1 KEY) (DOLBY NR TYPE B/C)
S303	1-571-627-11	SWITCH, SLIDE (DECK A TAPE SELECT)
S304	1-571-628-11	SWITCH, SLIDE (DECK B TAPE SELECT)
S501	1-571-510-11	SWITCH, PUSH (1 KEY) (DUBBING SPEED)
S701	1-570-393-11	SWITCH, PUSH (1 KEY) (POWER)
S905	1-571-714-11	(DECK-B)... SWITCH, LEAF (REC)
S910	△.1-570-307-11	(E)... SWITCH, VOLTAGE CHANGE
SPK101	1-235-186-00	ENCAPSULATED COMPONENT
SPK201	1-235-186-00	ENCAPSULATED COMPONENT
T301	1-433-303-11	TRANSFORMER, BIAS OSCILLATION
T901	△.1-448-804-11	(TC-W300 ; US, Canadian/TC-W190) ... TRANSFORMER, POWER
T901	△.1-448-805-11	(TC-W300 ; AEP, UK)... TRANSFORMER, POWER
T901	△.1-448-806-11	(TC-W300 ; E)... TRANSFORMER, POWER

Part No.	Description	Remark
ACCESSORY & PACKING MATERIAL		
1-559-533-11	CORD, CONNECTION	
* 3-346-344-01	CUSHION	
* 3-346-378-21	(TC-W300)... INDIVIDUAL CARTON	
* 3-346-378-31	(TC-W190)... INDIVIDUAL CARTON	
3-703-450-01	(TC-W300 ; US/TC-W190)... INSTRUCTION	
* 3-704-343-01	SHEET (STANDARD), PROTECTION	
3-786-251-11	(TC-W300 ; AEP, Canadian, E)... MANUAL, INSTRUCTION	
3-786-251-21	(TC-W300 ; US, UK)... MANUAL, INSTRUCTION	
3-786-251-41	(TC-W300 ; AEP)... MANUAL, INSTRUCTION	
3-786-251-51	(TC-W190)... MANUAL, INSTRUCTION	

Note:
The components identified by mark **△** or dotted line with mark **△** are critical for safety. Replace only with part number specified.

Note:
Les composants identifiés par une marque **△** sont critiques pour la sécurité. Ne les remplacer que par une pièce portant le numéro spécifié.

9-953-365-13
(Including 9-953-365-81)
9-953-365-82)

Sony Corporation
Audio Group

English
9110408-1(2)
Printed in Japan
© 1988. 7