

TC-W301/W306

SERVICE MANUAL

US Model

TC-W301

TC-W306

Canadian Model

E Model

Australian Model

TC-W301

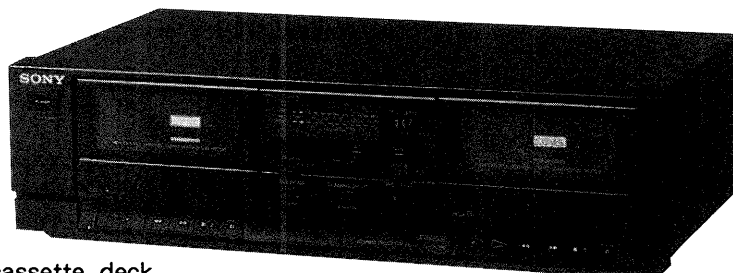

TC-W306 is the cassette deck section in SEN-501.

TC-W301 is the cassette deck section in SEN-301.

Photo : TC-W306

SPECIFICATIONS

Recording system

4-track 2-channel stereo

Fast-forward and rewind time

Approx. 120 sec. (with C-60 cassette)

Bias

AC bias

Signal-to-noise ratio (NAB, at peak level)

Dolby NR switch Cassette	OFF	ON
	TYPE IV (Sony METAL-ES)	58 dB
TYPE II (Sony UX-S)	56 dB	63 dB
TYPE I (Sony HF-S)	54 dB	61 dB

Total harmonic distortion

1.0% (with Sony METAL-ES cassette)

Frequency response (DOLBY NR OFF)

TYPE IV cassette (Sony METAL-ES)	30 – 15,000 Hz (± 3 dB) 30 – 13,000 Hz (0VU recording)
TYPE II cassette (Sony UX-S)	30 – 14,000 Hz (± 3 dB)
TYPE I cassette (Sony HF-S)	30 – 13,000 Hz (± 3 dB)

Wow and flutter 0.12% WRMS (NAB)

Input (TC – W306)

Connector	Type	Sensitivity	Impedance
LINE IN	phono	77.5 mV (-20 dB)	50 k ohms

Model Name Using Similar Mechanism		TC-W295/W390
Tape Transport Mechanism Type	DECK A	W301 : TCM-180VAH1 W306 : TCM-180VAH5
	DECK B	W301 : TCM-180VBH1 W306 : TCM-180VBH5

Output (TC – W306)

Connector	Type	Rated output level	Load impedance
LINE OUT	phono	0.44 V (-5 dB) at load impedance 47 k ohms	over 10 k ohms

General (TC – W306)

Power requirements

120 V AC, 60 Hz

Power consumption

15 W

Dimensions

Approx. 430 × 118 × 250 mm (w/h/d)
(17 × 4 $\frac{3}{4}$ × 9 $\frac{7}{8}$ inches)

including projecting parts and controls

Weight

Approx. 3.4 kg (7 lbs 8 oz)

Dolby noise reduction manufactured under license from
Dolby Laboratories Licensing Corporation.
"DOLBY" and the double-D symbol  are trademarks of
Dolby Laboratories Licensing Corporation.

STEREO CASSETTE DECK
SONY®



SERVICING NOTE FOR TC-W301

[To supply B+ voltage]

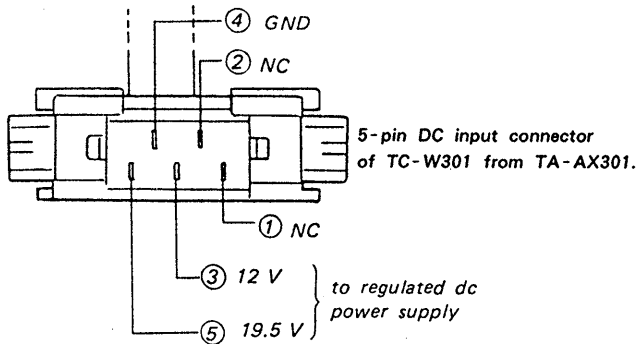
When this model alone operates, connect the unit to the regulated DC power supply, since power of this model is fed from TA-AX301.



SAFETY-RELATED COMPONENT WARNING!!

COMPONENTS IDENTIFIED BY MARK  OR DOTTED LINE WITH MARK  ON THE SCHEMATIC DIAGRAMS AND IN THE PARTS LIST ARE CRITICAL TO SAFE OPERATION. REPLACE THESE COMPONENTS WITH SONY PARTS WHOSE PART NUMBERS APPEAR AS SHOWN IN THIS MANUAL OR IN SUPPLEMENTS PUBLISHED BY SONY.

ATTENTION AU COMPOSANT AYANT RAPPORT À LA SÉCURITÉ!

LES COMPOSANTS IDENTIFIÉS PAR UNE MARQUE  SUR LES DIAGRAMMES SCHÉMATIQUES ET LA LISTE DES PIÈCES SONT CRITIQUES POUR LA SÉCURITÉ DE FONCTIONNEMENT. NE REMPLACER CES COMPOSANTS QUE PAR DES PIÈCES SONY DONT LES NUMÉROS SONT DONNÉS DANS CE MANUEL OU DANS LES SUPPLÉMENTS PUBLIÉS PAR SONY.

SAFETY CHECK-OUT

After correcting the original service problem, perform the following safety check before releasing the set to the customer:

Check the antenna terminals, metal trim, "metallized" knobs, screws, and all other exposed metal parts for AC leakage. Check leakage as described below.

LEAKAGE TEST

The AC leakage from any exposed metal part to earth ground and from all exposed metal parts to any exposed metal part having a return to chassis, must not exceed 0.5 mA (500 microamperes). Leakage current can be measured by any one of three methods.

1. A commercial leakage tester, such as the Simpson 229 or RCA WT-540A. Follow the manufacturers' instructions to use these instruments.
2. A battery-operated AC milliammeter. The Data Precision 245 digital multimeter is suitable for this job.
3. Measuring the voltage drop across a resistor by means of a VOM or battery-operated AC voltmeter. The "limit" indication is 0.75 V, so analog meters must have an accurate low-voltage scale. The Simpson 250 and Sanwa SH-63Trd are examples of a passive VOM that is suitable. Nearly all battery operated digital multimeters that have a 2V AC range are suitable. (See Fig. A)

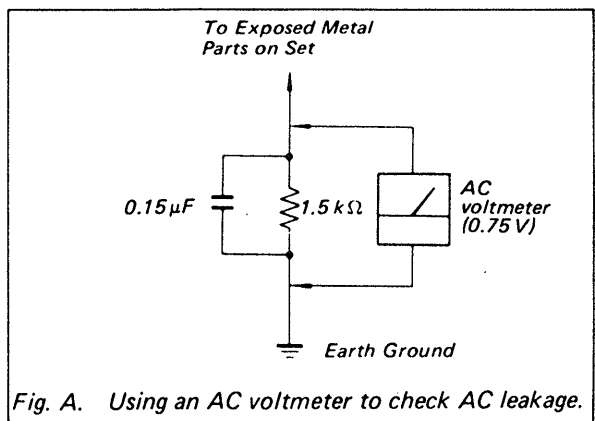

SECTION 1 ADJUSTMENTS

1-1. MECHANICAL ADJUSTMENTS

PRECAUTION

- Clean the following parts with a denatured-alcohol-moistened swab:

record/playback head	pinch roller
erase head	rubber belts
capstan	idlers

Torque Measurement (DECKS A and B)

Torque	Torque ment	Meter reading
FWD	CQ-102C	35 - 70 g·cm (0.49 - 0.97 oz·inch)
FF, REW	CQ-201B	70 - 160 g·cm (0.98 - 2.22 oz·inch)

1-2. ELECTRICAL ADJUSTMENTS

- Demagnetize the record/playback and erase head with a head demagnetizer.
 - Do not use a magnetized screwdriver for the adjustments.
 - After the adjustments, apply suitable locking compound to the parts adjusted.
 - The adjustments should be performed with the rated power supply voltage unless otherwise noted.
 - The adjustments should be performed in the order given in this service manual. (As a general rule, playback circuit adjustment should be completed before performing recording circuit adjustment.)
 - The adjustments should be performed for both L-CH and R-CH.
- Switches and controls should be set as follows unless otherwise specified.

DOLBY NR switch: OFF
TAPE SELECT switch: TYPE I (NORMAL)

- Standard Record:
Deliver the standard input signal level to the input jack and set the REC LEVEL control to obtain the standard output signal level.

Record Mode -

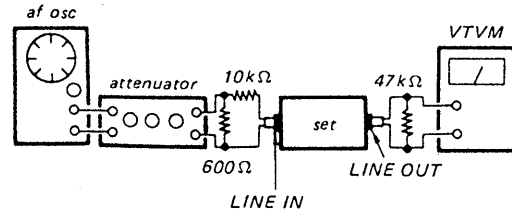

Note: Before recording short CNS05 with a lead wire, otherwise MUTING functions and output signal does not appear at LINE OUT terminals.

Standard Input Level

	LINE IN
source impedance	10 kΩ
input level	0.25 V (-10dB)

Standard Output Level

	LINE OUT
load impedance	47 kΩ
output level	0.44 V (-5dB)

Record/Playback Head Azimuth Adjustment

DECK A
DECK B

Procedure:

- Mode: FWD playback

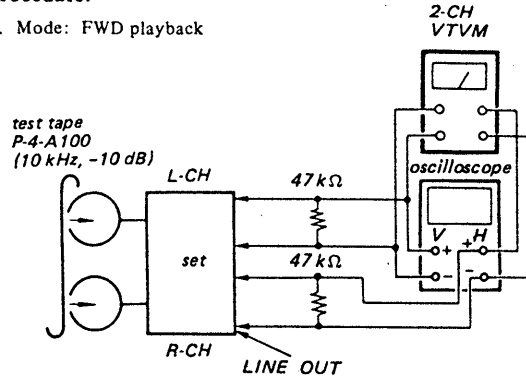

- Turn the adjustment screw and check output peaks. If the peaks do not match for L-CH and R-CH, turn the adjustment screw so that outputs match within 1 dB of peak.

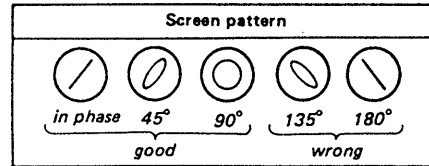
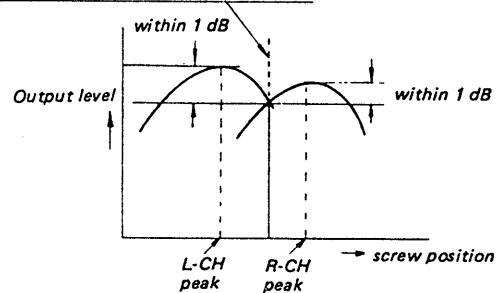

- After the adjustment, apply suitable locking compound to the adjustment screw.

Adjustment Location:

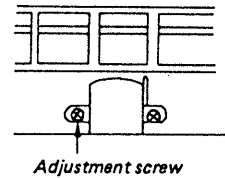

Test Tape:

Type	Signal	Used for
P-4-A100	10kHz, -10dB	Azimuth Adjustment
P-4-L300	315Hz, 0dB	Level Adjustment
WS-48A	3kHz, 0dB	Tape Speed Adjustment

[LINE IN/OUT for TC-W301] : CN321

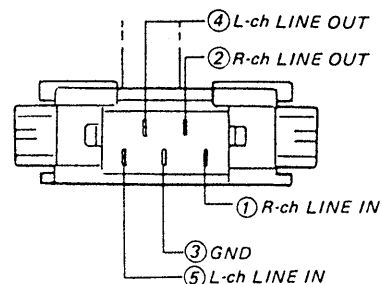

**SECTION 2
DIAGRAMS**

2-1. SEMICONDUCTOR LEAD LAYOUTS

Tape Speed Adjustment **DECK A**
DECK B

Procedure:
Mode: FWD playback
test tape WS-48A (3 kHz, 0 dB)
speed checker or digital frequency counter

1. Short the pins of CN504 with a wire to set the high speed mode.

Measurement limits: high speed

Speed checker	Digital frequency counter
±0.3%	6,000 ± 20 Hz

Frequency difference between the beginning and the end of the tape should be within 1.5% (90 Hz).

Adjustment Location:
DECK-A: RV501
DECK-B: RV503

2. Remove the wire in step 1. (CN504)

Measurement limits: normal speed

Speed checker	Digital frequency counter
±0.3%	3,000 ± 10 Hz

Frequency difference between the beginning and the end of the tape should be within 1.5% (45 Hz).

Adjustment Location:
DECK-A: RV502
DECK-B: RV504

3. If the specifications are not satisfied, repeat step 1 and 2.

Playback Level Adjustment **DECK A**
DECK B

Procedure:
Mode: FWD playback
test tape P-4-L300 (315 Hz, 0 dB)
VTVM

Adjust,
DECK-A: RV101 (L-CH), RV201 (R-CH)
DECK-B: RV102 (L-CH), RV202 (R-CH)
so that the measurement limits are satisfied.

Measurement limits:
LINE OUT level: 0.130 - 0.146 V (-15 ± 0.5 dB)
level difference between the channels: within 0.5 dB

Record Bias Current Adjustment **DECK B**

Setting:
REC LEVEL control: standard record (See page 3.)

Procedure:
1. Mode: record
AF OSC
blank tape CS-122

2. Mode: playback
CS-122 (recorded in step 1.)
VTVM

Playback the tape record in step 1. If the measurement limits is not satisfied, adjust C408-1 (L-CH), C408-2 (R-CH) and repeat steps 1 and 2.

Measurement limits:
The LINE OUT level of 10 kHz signal relative to that of 315 Hz: -0.5 dB to 0.5 dB.

Record Level Adjustment **DECK B**

Setting:
REC LEVEL control: standard record (See page 3.)

Procedure:
1. Mode: record
AF OSC
blank tape CS-122

2. Mode: playback
CS-122 (recorded in step 1.)
VTVM

Playback the tape recorded in step 1. If the measurement limits is not satisfied, adjust RV141 (L-CH), RV241 (R-CH) and repeat steps 1 and 2. If the level difference between the channels is still 1 dB or more, divide it to the both channels on the basis of -5 dB.

Measurement limits:
LINE OUT level: 0.041 - 0.045 V (-25 ± 0.5 dB)

Adjustment Location:
[AUDIO BOARD] - COMPONENT SIDE -

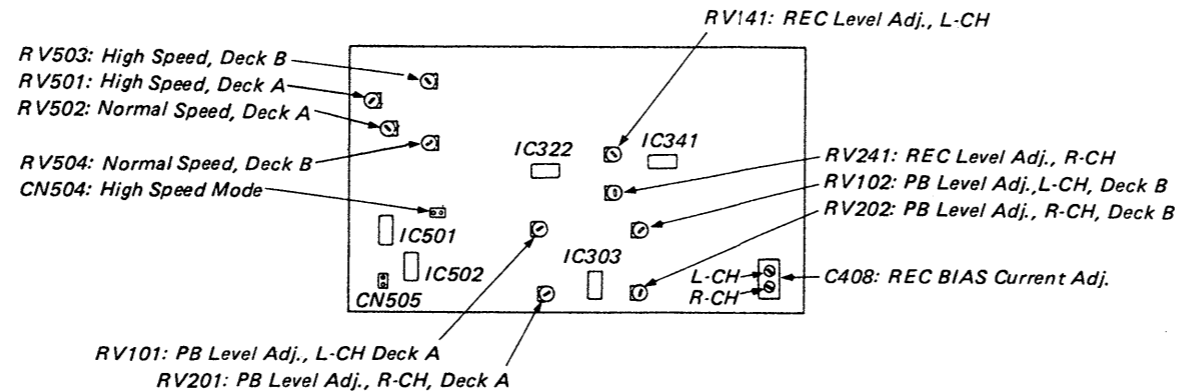

<p>CXA1100P CXA1198AP TC4051BPHB</p>	<p>2SC945-P 2SC1815Y 2SD1387</p>
<p>IR2E31A</p>	<p>2SD2012</p>
<p>LA3160</p>	<p>HZS6A1L HZL11CH2</p>
<p>MC14066BCP μPD4011BC TC4001BP</p>	<p>SEL1210S-C SEL1910A-C</p>
<p>2SC3623A-LK</p>	<p>SEL4214S</p>
<p>DTA114ES DTA144ES DTC114ES DTC144ES 2SC2603-EF</p>	<p>1SS202-1 10E2N</p>

● SEMICONDUCTOR LOCATION

Ref. No.	Location	Ref. No.	Location
D191	C-4	IC191	D-4
D192	C-4	IC291	D-3
D193	C-3	IC301	C-9
D194	C-3	IC302	C-12
D195	C-2	IC303	C-11
D196	C-4	IC322	F-10
D291	C-4	IC341	F-13
D292	C-4	IC342	G-13
D293	C-3	IC501	D-6
D294	C-3	IC502	C-7
D295	C-2		
D296	C-4	Q101	D-11
D401	E-14	Q121	G-11
D402	C-14	Q141	F-12
D501	F-14	Q201	D-11
D504	C-7	Q221	G-12
D505	D-7	Q241	E-12
D506	D-6	Q321	E-11
D507	D-6	Q401	E-14
D510	C-8	Q402	E-15
D511	E-6	Q403	E-14
D512	C-7	Q404	E-14
D513	E-6	Q405	E-14
D514	D-3	Q501	G-6
D515	D-2	Q502	F-7
D516	F-6	Q503	E-7
D517	E-6	Q504	F-7
D518	F-6	Q505	F-7
D601	H-7	Q506	F-7
D602	G-7	Q507	E-7
D603	G-7	Q508	E-6
D604	H-7	Q509	C-6
D605	G-10	Q511	E-7
D606	G-8	Q512	E-6
D607	G-8	Q601	H-10
D608	H-9	Q602	H-9
		Q603	H-10
		Q605	H-10

2-2. PRINTED WIRING BOARDS

● See page 5 for semiconductor lead layouts.

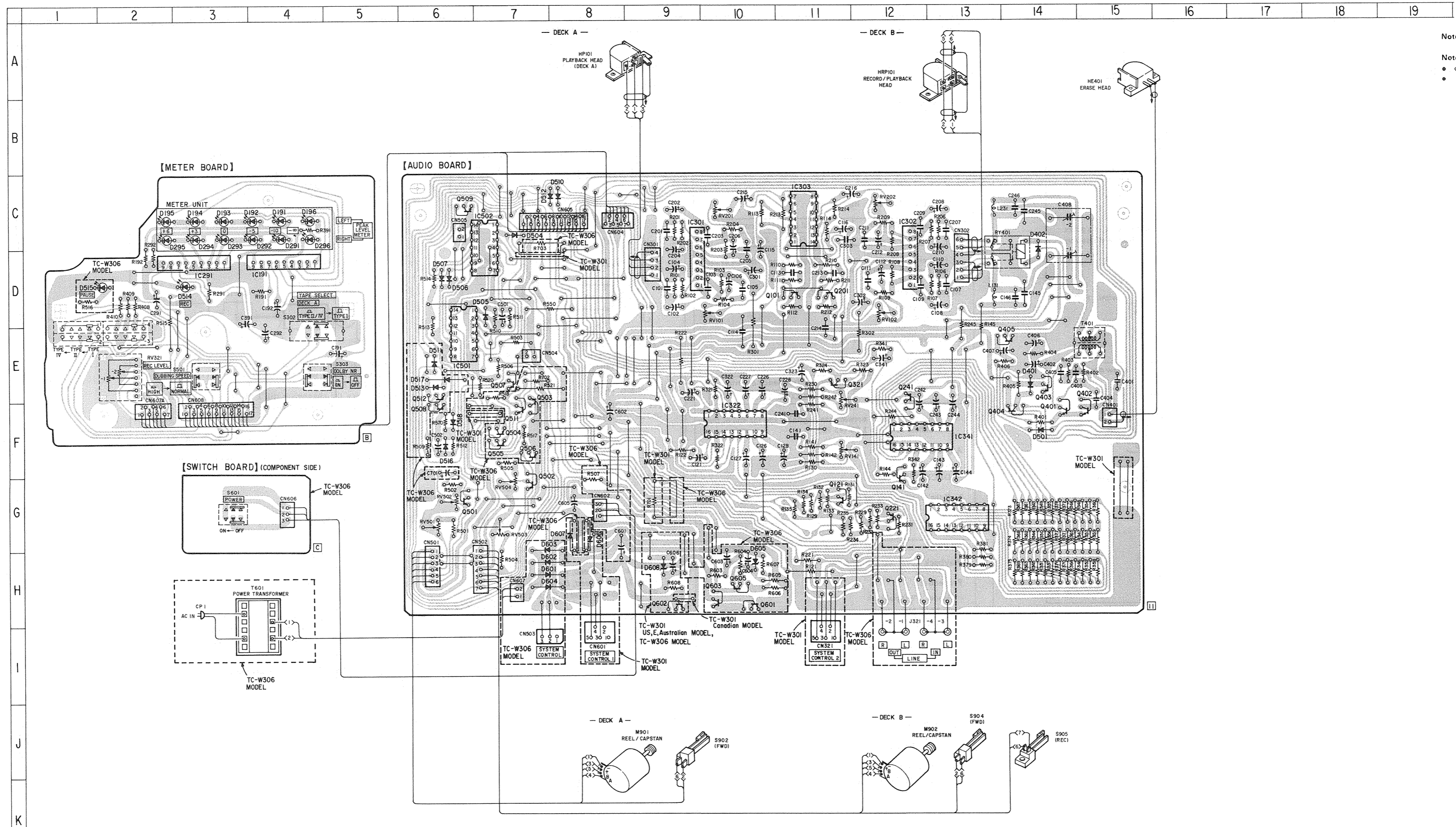

2-3. SCHEMATIC DIAGRAM

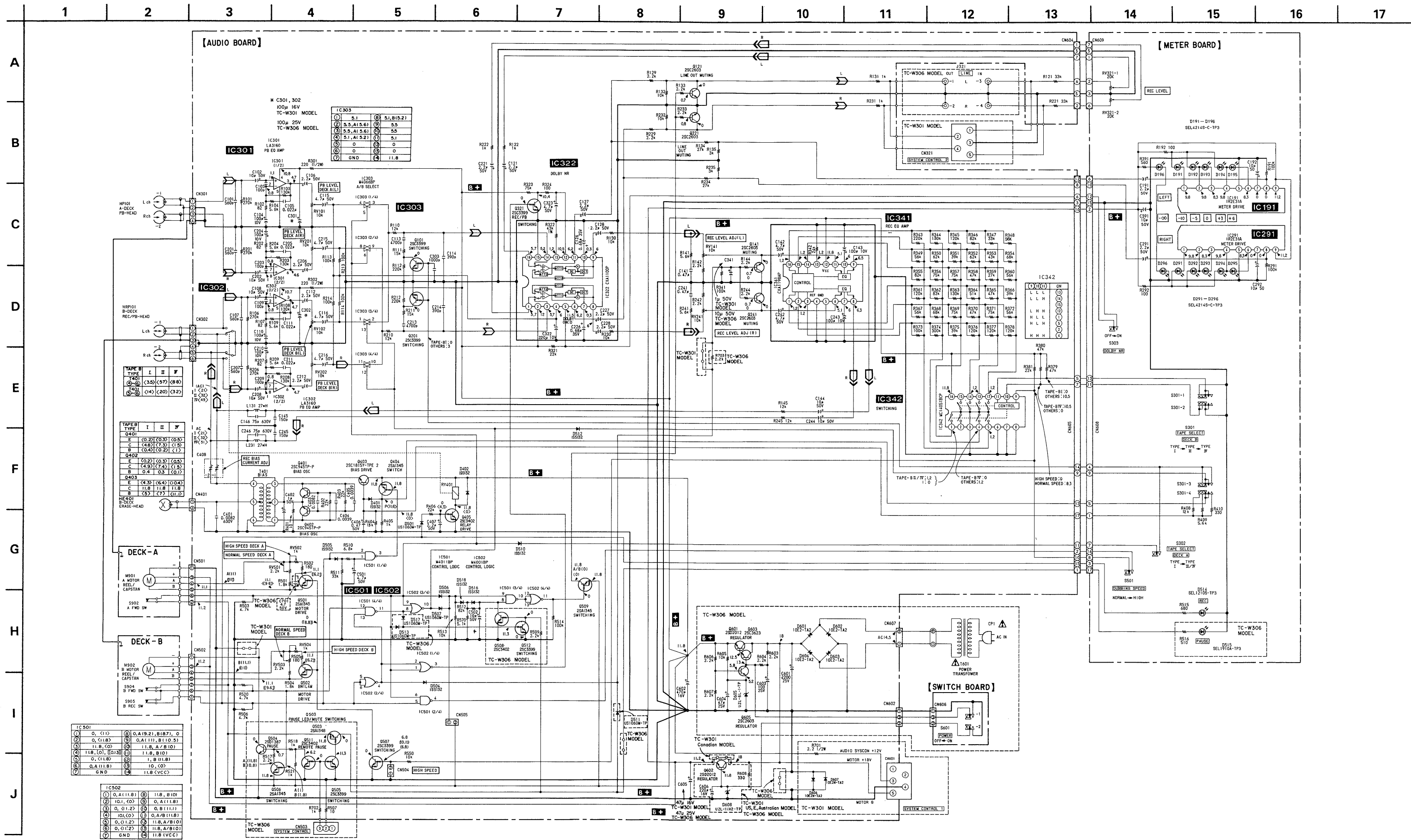

Note on Schematic Diagram:

Note:

- All capacitors are in μF unless otherwise noted. pF: μF 50WV or less are not indicated except for electrolytics and tantalums.
- All resistors are in Ω and $\frac{1}{2}\text{W}$ or less unless otherwise specified.
- \square : adjustment for repair.
- AC voltage readings in the bias oscillator with a VTVM.
- Voltage and waveforms are dc with respect to ground under no-signal conditions. no mark: STOP
- A (): PB (DECK A)
- B (): PB (DECK B)
- < > : REC (DECK B)
- [] : DUBBING (NORMAL)
- [] : DUBBING (HIGH)
- Volts are taken with a VOM (Input impedance 10M Ω).
- Voltage variations may be noted due to normal production tolerances.
- Signal path.
- \square : PB (DECK A)
- \square : PB (DECK B)
- \square : REC (DECK B)

Note: The components identified by mark Δ or dotted line with mark Δ are critical for safety. Replace only with part number specified.

Note: Les composants identifiés par une marque Δ sont critiques pour la sécurité. Ne les remplacer que par une pièce portant le numéro spécifié.

IC 501

①	0.1 (1)	⑥	0.1 (9, 21, B1, B7), 0
②	0.1 (1, 8)	⑦	0.1 (11, B1, 1, 5)
③	11.8 (CO)	⑧	11.8, A/B (O)
④	11.8 (O), (O1)	⑨	11.8, B1 (O)
⑤	0.1 (11, 8)	⑩	11.8 (11, 8)
⑪	0.1 (11, 8)	⑪	10, CO
⑫	0.1 (11, 8)	⑫	11.8 (VCC)
⑬	GND	⑬	11.8 (VCC)

IC 502

①	0.1 (11, 8)	⑥	11.8, B1 (O)
②	101, CO	⑦	0, A1 (1, 8)
③	0, 0.1 (2)	⑧	0, B1 (1, 1)
④	101, CO	⑨	0, A/B (11, 8)
⑤	0, 0.1 (2)	⑩	11.8, A/B1 (O)
⑪	0, 0.1 (2)	⑪	11.8, A/B1 (O)
⑫	GND	⑫	11.8 (VCC)

SECTION 3 EXPLODED VIEWS

NOTE:

- The mechanical parts with no reference number in the exploded views are not supplied.
- The construction parts of an assembled part are indicated with a collation number in the remark column.
- Items marked "★" are not stocked since they are seldom required for routine service. Some delay should be anticipated when ordering these items.

- Due to standardization, parts with part number suffix -XX and -X may be different from the parts specified in the components used on the set.
- Color Indication of Appearance Parts Example:
 (RED) ... KNOB, BALANCE (WHITE)
 ↑ Cabinet's Color ↑ Parts' Color
- AUS: Australian model

The components identified by mark Δ or dotted line with mark Δ are critical for safety. Replace only with part number specified.

Les composants identifiés par une marque Δ sont critiques pour la sécurité. Ne les remplacer que par une pièce portant le numéro spécifié.

(1) GENERAL

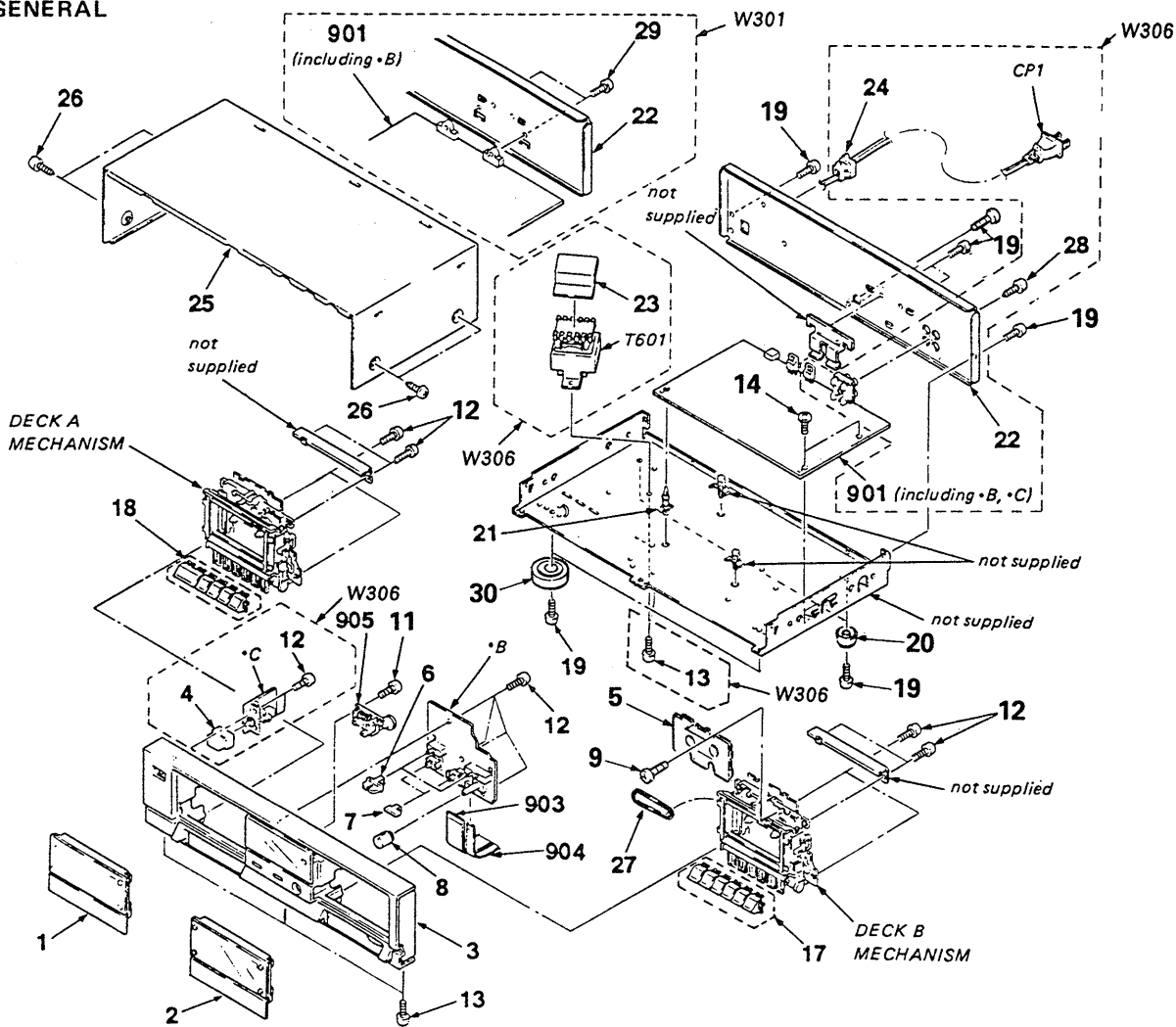

No.	Part No.	Description	Remarks	No.	Part No.	Description	Remarks
1	X-3340-190-1	LID (A) ASSY, CASSETTE		22	*3-349-023-21	(W301)...PANEL, BACK	
2	X-3340-189-1	LID (B) ASSY, CASSETTE			*3-349-023-31	(W306)...PANEL, BACK	
3	X-3340-191-1	(W301)...PANEL ASSY, FRONT		23	*3-327-855-01	(W306)...COVER (TRANSFORMER)	
	X-3346-302-1	(W306)...PANEL ASSY, FRONT		24	*3-703-571-11	(W306)...BUSHING (S) (4516), CORD CASE	
4	3-354-912-01	(W306)...KNOB, POWER		25	3-327-856-61		
5	X-3358-214-1	PLATE ASSY, ORNAMENTAL		26	3-704-366-01	SCREW (CASE) (M3X8)	
6	3-346-379-01	KNOB (SLIDE)		27	3-499-042-XX	BELT, COUNTER	
7	3-346-381-01	BUTTON		28	7-621-849-00	(W306)...SCREW, TAPPING	
8	3-349-039-01	KNOB (VOL)		29	7-685-646-79	(W301)...SCREW, +BVTP 3X8 TYPE 2	
9	7-685-133-19	SCREW +BTP 2.6X6 TYPE2 N-S		30	X-3340-138-1	(W301:US,Canadian,W306)...FOOT ASSY	
11	4-928-635-01	SCREW, +BV (2.6X8) TAPPING			X-3340-173-1	(W301:E,AUS).....FOOT ASSY	
12	4-928-635-21	SCREW, +BV (2.6X10) TAPPING		901	*A-2006-071-A	(W301:US,E,AUS)...MOUNTED PCB, AUDIO	
13	7-682-548-04	(W306)...SCREW +BVTT 3X8 (S)			*A-2006-072-A	(W306).....MOUNTED PCB, AUDIO	
14	4-886-821-11	(W301)...SCREW, S TIGHT, +PITWH 3X6			*A-2006-138-A	(W301:Canadian)...MOUNTED PCB, AUDIO	
	7-682-548-09	(W306)...SCREW, +BVTP 3X8 (S)		903	1-574-724-11	WIRE, FLAT TYPE (17 CORE)	
17	3-349-043-11	BUTTON (BLOCK B)		904	1-574-723-11	WIRE, FLAT TYPE (7 CORE)	
18	3-349-042-11	BUTTON (BLOCK A)		905	1-548-596-61	COUNTER, TAPE (MIDDLE TYPE)	
19	7-682-548-09	SCREW +BVTT 3X8 (S)		CP1	Δ 1-558-945-11	(W306)...CORD, POWER (POLAR.SPT-1)	
20	X-4904-496-1	FOOT ASSY		T601	Δ 1-449-256-11	(W306)...TRANSFORMER, POWER	
21	*3-346-265-11	HOLDER, PC BOARD					

(2) MECHANISM SECTION-1

DECK A : TCM-180VA-H1 (W301), TCM-180VA-H5 (W306)

DECK B : TCM-180VB-H1 (W301), TCM-180VB-H5 (W306)

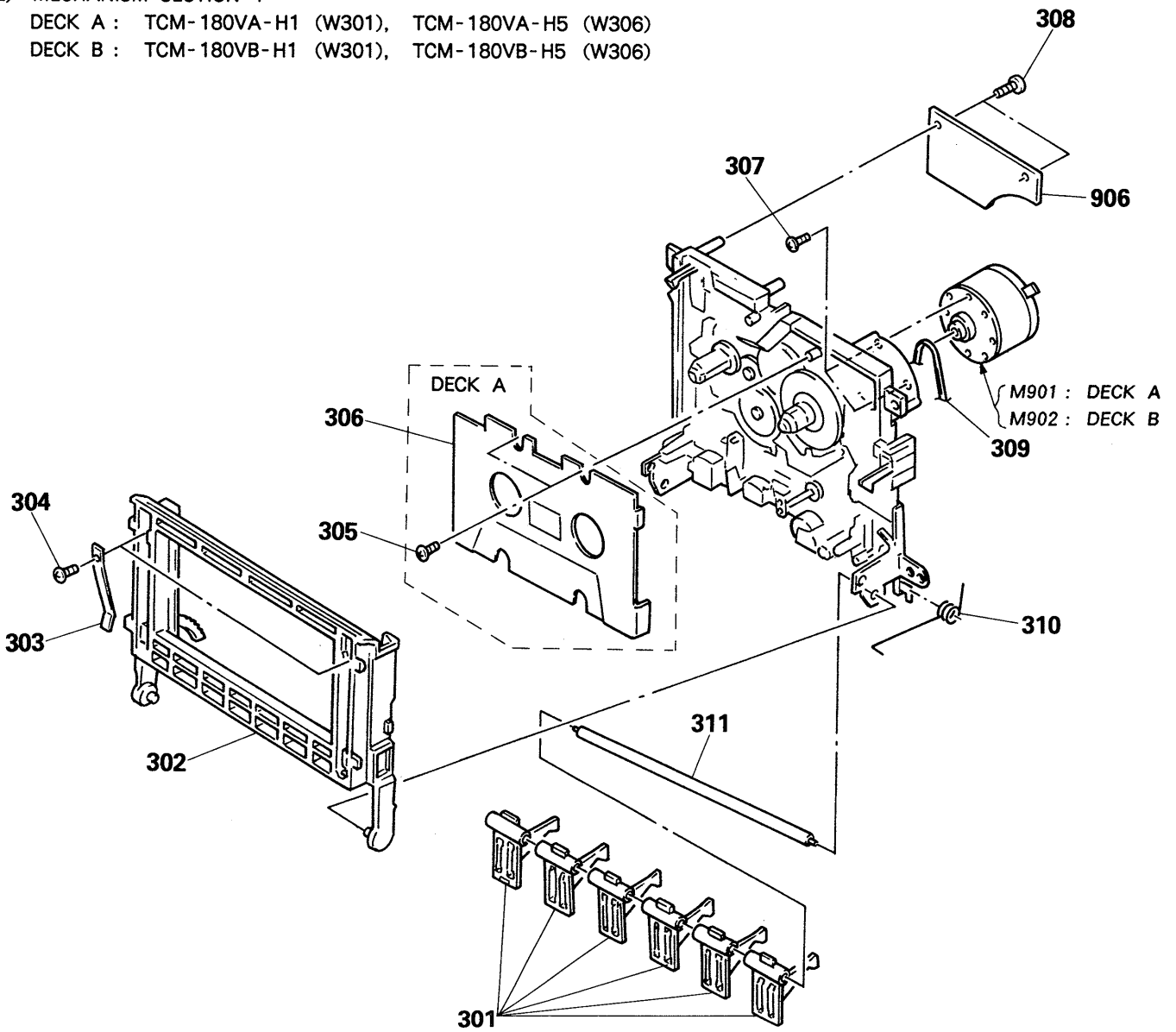

No.	Part No.	Description	Remarks	No.	Part No.	Description	Remarks
301	3-358-271-01	LEVER (BUTTON BASE A)		308	7-685-133-19	SCREW +BTP 2.6X6 TYPE2 N-S	
302	3-358-266-01	HOLDER, CASSETTE		309	3-358-272-01	BELT (A2)	
303	3-358-209-01	SPRING (CASSETTE HOLDER), LEAF		310	3-358-287-01	SPRING (LOADING A), TORSION	
304	7-685-103-19	SCREW +P 2X5 TYPE2 NON-SLIT		311	3-358-242-01	SHAFT (BUTTON SHAFT)	
305	7-685-132-19	(DECK A)...SCREW +BTP 2.6X5 TYPE2 N-S		906	*1-635-158-11	PC BOARD, SW	
306	X-3358-214-1	(DECK A)...PLATE ASSY, ORNAMENTAL		M901	X-3358-212-1	MOTOR (B) ASSY	
307	7-621-775-20	SCREW +B 2.6X5		M902	X-3358-212-1	MOTOR (B) ASSY	

(3) MECHANISM SECTION-2

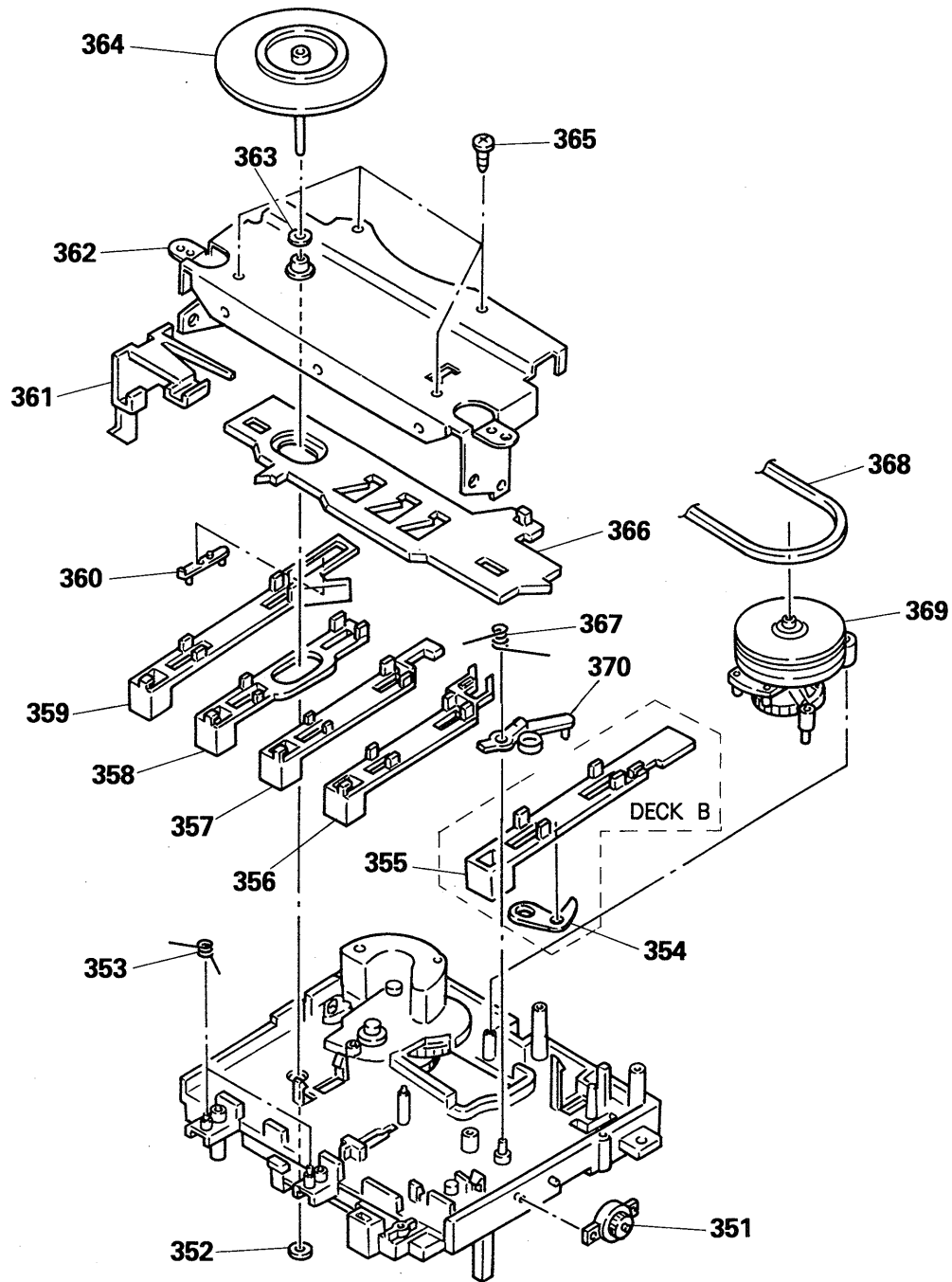

No.	Part No.	Description	Remarks	No.	Part No.	Description	Remarks
351	3-319-224-31	DAMPER, SMALL		362	*X-3358-213-1	BRACKET (A) ASSY	
352	7-623-921-01	WASHER 1.7, NYLONE		363	3-701-437-01	WASHER	
353	3-358-232-01	SPRING (S-P F-R), TORSION		364	X-3358-205-1	FLYWHEEL (A) ASSY	
354	*3-358-204-01	(DECK B)...LEVER (REC SAFETY)		365	7-685-133-19	SCREW +P 2.6X6 TYPE1	
355	3-358-259-01	(DECK B)...SLIDER (REC)		366	*3-358-249-01	SLIDER (LOCK PLATE)	
356	3-358-258-01	SLIDER (REW)		367	3-358-214-01	(DECK A)...SPRING (LOCK), TORSION	
357	3-358-257-01	SLIDER (FF)			3-358-233-01	(DECK B)...SPRING (REC-LOCK), TORSION	
358	3-358-256-01	SLIDER (STOP/EJECT)		368	3-358-230-01	BELT (A1)	
359	3-358-260-01	SLIDER (PAUSE)		369	X-3358-202-1	LEVER (FR ARM) ASSY	
360	*3-358-226-01	LEVER (PAUSE LEVER)		370	*3-358-286-01	LEVER (MOTOR LEVER)	
361	*3-358-261-01	SLIDER (HOLDER LOCK)					

(4) MECHANISM SECTION-3

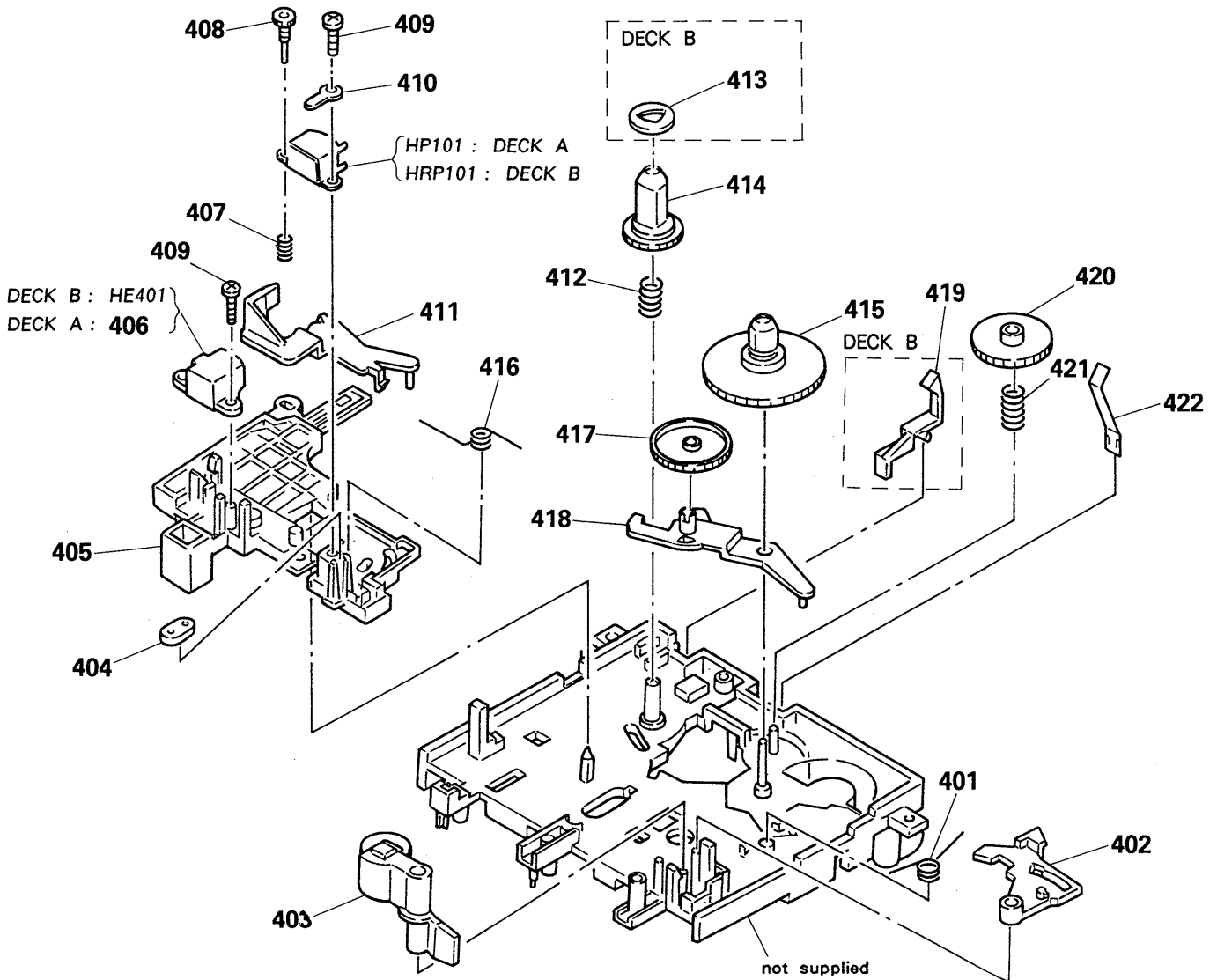

No.	Part No.	Description	Remarks	No.	Part No.	Description	Remarks
401	3-358-243-01	SPRING (TU-SHUT), TORSION		414	3-358-248-01	GEAR (SUPPLY REEL)	
402	*3-358-253-01	LEVER (SHUT-OFF LEVER)		415	X-3358-203-1	TABLE (T) ASSY, REEL	
403	X-3358-204-1	LEVER (PINCH LEVER) ASSY		416	3-358-228-01	SPRING, TORSION	
404	*3-358-215-01	BUSHING (WIRE KIT RETAINER)		417	*3-358-284-01	GEAR (TU GEAR)	
405	3-358-265-01	SLIDER (HEAD PC BOARD A)		418	*3-358-252-01	LEVER (TU ARM)	
406	3-358-285-01	(DECK A)...GUIDE, TAPE		419	*3-358-255-01	(DECK B)...LEVER (GB LEVER)	
407	3-358-234-01	SPRING (AZIMUTH), COMPRESSION		420	*3-358-224-01	GEAR (FF GEAR)	
408	3-358-213-01	SCREW, AZIMUTH		421	3-358-207-01	SPRING (FF GEAR), COMPRESSION	
409	7-685-105-19	TPG +P 2X8, TYPE 2, NON-SLIT		422	3-358-227-01	SPRING, LEAF	
410	7-623-505-01	LUG, 2		HE401	1-543-673-11	HEAD, MAGNETIC (ERASE)	
411	*3-358-251-01	LEVER (TENSION DETECTION ARM)		HP101	1-543-672-11	HEAD, MAGNETIC (REC/PB)	
412	3-358-208-01	SPRING (SUPPLY), COMPRESSION		HRP101	1-543-672-11	HEAD, MAGNETIC (REC/PB)	
413	*3-358-270-01	(DECK B)...PULLEY (COUNTER PULLEY)					

SECTION 4 ELECTRICAL PARTS LIST

NOTE:

- Due to standardization, replacements in the parts list may be different from the parts specified in the diagrams or the components used on the set.
- Items marked "*" are not stocked since they are seldom required for routine service. Some delay should be anticipated when ordering these items.
- If there are two or more same circuits in a set such as a stereophonic machine, only typical circuit parts may be indicated and capacitors and resistors in other same circuits may be omitted.

CAPACITORS:

MF: μ F, PF: μ μ F.

RESISTORS

- All resistors are in ohms.
- F: nonflammable

COILS

- MMH: mH, UH: μ H

SEMICONDUCTORS

In each case, U: μ , for example:

UA...: μ A..., UPA...: μ PA...,

UPC...: μ PC, UPD...: μ PD...

The components identified by mark Δ or dotted line with mark Δ are critical for safety. Replace only with part number specified.

Les composants identifiés par une marque Δ sont critiques pour la sécurité. Ne les remplacer que par une pièce portant le numéro spécifié.

• AUS: Australian model

Ref.No.	Part No.	Description					Ref.No.	Part No.	Description					
901	*A-2006-071-A	(W301:US,E,AUS)...MOUNTED PCB, AUDIO					C212	1-126-161-11	ELECT	2.2MF	20%	50V		
	*A-2006-072-A	(W306).....MOUNTED PCB, AUDIO					C213	1-161-377-00	CERAMIC	0.0047MF	20%	16V		
	*A-2006-138-A	(W301:Canadian)...MOUNTED PCB, AUDIO					C214	1-162-289-31	CERAMIC	390PF	10%	50V		
903	1-574-724-11	WIRE, FLAT TYPE (17 CORE)					C215	1-124-045-00	ELECT	4.7MF	20%	50V		
904	1-574-723-11	WIRE, FLAT TYPE (7 CORE)					C216	1-124-045-00	ELECT	4.7MF	20%	50V		
905	1-548-596-61	COUNTER, TAPE (MIDDLE TYPE)					C221	1-126-161-11	ELECT	2.2MF	20%	50V		
906	*1-635-158-11	PC BOARD, SW					C226	1-131-587-11	TANTALUM	0.68MF	10%	35V		
C101	1-162-291-31	CERAMIC	560PF	10%	50V	C227	1-124-257-00	ELECT	2.2MF	20%	50V			
C102	1-126-059-11	ELECT	10MF	20%	50V	C228	1-126-161-11	ELECT	2.2MF	20%	50V			
C103	1-162-282-31	CERAMIC	100PF	10%	50V	C241	1-136-173-00	FILM	0.47MF	5%	50V			
C104	1-124-994-11	ELECT	100MF	20%	10V	C242	1-124-045-00	ELECT	4.7MF	20%	50V			
C105	1-136-157-00	FILM	0.022MF	5%	50V	C243	1-124-994-11	ELECT	100MF	20%	10V			
C106	1-126-161-11	ELECT	2.2MF	20%	50V	C244	1-126-059-11	ELECT	10MF	20%	50V			
C107	1-162-291-31	CERAMIC	560PF	10%	50V	C245	1-162-284-31	CERAMIC	150PF	10%	50V			
C108	1-126-059-11	ELECT	10MF	20%	50V	C246	1-136-273-91	FILM	75PF	5%	630V			
C109	1-162-282-31	CERAMIC	100PF	10%	50V	C291	1-126-161-11	ELECT	2.2MF	20%	50V			
C110	1-124-994-11	ELECT	100MF	20%	10V	C292	1-126-059-11	ELECT	10MF	20%	50V			
C111	1-136-157-00	FILM	0.022MF	5%	50V	C301	1-124-478-11	(W306)...ELECT	100MF	20%	25V			
C112	1-126-161-11	ELECT	2.2MF	20%	50V	C301	1-126-023-11	(W301)...ELECT	100MF	20%	16V			
C113	1-161-377-00	CERAMIC	0.0047MF	20%	16V	C302	1-124-478-11	(W306)...ELECT	100MF	20%	25V			
C114	1-162-289-31	CERAMIC	390PF	10%	50V	C302	1-126-023-11	(W301)...ELECT	100MF	20%	16V			
C115	1-124-045-00	ELECT	4.7MF	20%	50V	C303	1-162-294-31	CERAMIC	0.001MF	10%	50V			
C116	1-124-045-00	ELECT	4.7MF	20%	50V	C322	1-126-101-11	ELECT	220MF	20%	10V			
C121	1-126-161-11	ELECT	2.2MF	20%	50V	C323	1-124-045-00	ELECT	4.7MF	20%	50V			
C126	1-131-587-11	TANTALUM	0.68MF	10%	35V	C341	1-126-059-11	(W306)...ELECT	10MF	20%	50V			
C127	1-124-257-00	ELECT	2.2MF	20%	50V	C341	1-126-301-11	(W301)...ELECT	1MF	20%	50V			
C128	1-126-161-11	ELECT	2.2MF	20%	50V	C391	1-126-059-11	ELECT	10MF	20%	50V			
C141	1-136-173-00	FILM	0.47MF	5%	50V	C401	1-136-562-11	FILM	0.0082MF	5%	630V			
C142	1-124-045-00	ELECT	4.7MF	20%	50V	C402	1-126-301-11	ELECT	1MF	20%	50V			
C143	1-124-994-11	ELECT	100MF	20%	10V	C403	1-130-482-00	MYLAR	0.0082MF	5%	50V			
C144	1-126-059-11	ELECT	10MF	20%	50V	C404	1-130-478-00	MYLAR	0.0039MF	5%	50V			
C145	1-162-284-31	CERAMIC	150PF	10%	50V	C405	1-130-478-00	MYLAR	0.0039MF	5%	50V			
C146	1-136-273-91	FILM	75PF	5%	630V	C406	1-126-300-11	ELECT	0.47MF	20%	50V			
C191	1-126-161-11	ELECT	2.2MF	20%	50V	C407	1-126-161-11	ELECT	2.2MF	20%	50V			
C192	1-126-059-11	ELECT	10MF	20%	50V	C408	1-141-225-00	CAP, TUNING, TRIMAR						
C201	1-162-291-31	CERAMIC	560PF	10%	50V	C501	1-124-045-00	ELECT	4.7MF	20%	50V			
C202	1-126-059-11	ELECT	10MF	20%	50V	C502	1-126-059-11	ELECT	10MF	20%	50V			
C203	1-162-282-31	CERAMIC	100PF	10%	50V	C601	1-124-962-11	(W306)...ELECT	2200MF	20%	25V			
C204	1-124-994-11	ELECT	100MF	20%	10V	C602	1-126-012-11	ELECT	470MF	20%	16V			
C205	1-136-157-00	FILM	0.022MF	5%	50V	C603	1-124-478-11	(W306)...ELECT	100MF	20%	25V			
C206	1-126-161-11	ELECT	2.2MF	20%	50V	C604	1-124-910-11	(W306)...ELECT	47MF	20%	25V			
C207	1-162-291-31	CERAMIC	560PF	10%	50V	C605	1-124-910-11	(W306)...ELECT	47MF	20%	25V			
C208	1-126-059-11	ELECT	10MF	20%	50V	C605	1-126-022-11	(W301)...ELECT	47MF	20%	16V			
C209	1-162-282-31	CERAMIC	100PF	10%	50V	C606	1-126-024-11	ELECT	220MF	20%	16V			
C210	1-124-994-11	ELECT	100MF	20%	10V	C701	1-124-045-00	(W306)...ELECT	4.7MF	20%	50V			
C211	1-136-157-00	FILM	0.022MF	5%	50V									

Ref.No.	Part No.	Description	Ref.No.	Part No.	Description
CN301	*1-564-507-11	PLUG, CONNECTOR 4P	IC191	8-759-917-42	IC IR2E31A
CN302	*1-564-509-11	PLUG, CONNECTOR 6P	IC291	8-759-917-42	IC IR2E31A
CN321	*1-566-856-11	(W301)...SOCKET, CONNECTOR 5P (SYSTEM CONTROL 2)	IC301	8-759-800-36	IC LA3160
CN401	*1-564-505-11	PLUG, CONNECTOR 2P	IC302	8-759-800-36	IC LA3160
CN503	*1-566-210-11	(W306)...PIN, CONNECTOR 3P (SYSTEM CONTROL)	IC303	8-759-000-49	IC MC14066BCP
CN504	*1-564-505-11	PLUG, CONNECTOR 2P	IC322	8-752-031-67	IC CXA1100P
CN505	*1-564-505-11	PLUG, CONNECTOR 2P	IC341	8-752-038-02	IC CXA1198AP
CN601	*1-566-856-11	(W301)...SOCKET, CONNECTOR 5P (SYSTEM CONTROL 1)	IC342	8-759-208-06	IC TC4051BPHB
CN602	*1-564-337-00	(W306)...PIN, CONNECTOR 3P	IC501	8-759-140-11	IC UPD4011BC
CN604	1-568-439-11	SOCKET, CONNECTOR 7P	IC502	8-759-240-01	IC TC4001BP
CN605	1-568-440-11	SOCKET, CONNECTOR 17P	J321	1-565-258-11	(W306)...JACK, PIN 4P (LINE IN/OUT)
CN608	1-568-438-11	SOCKET, CONNECTOR 17P	L131	1-410-780-11	INDUCTOR 27MMH
CN609	1-568-437-11	SOCKET, CONNECTOR 7P	L231	1-410-780-11	INDUCTOR 27MMH
CN901	*1-564-499-11	PIN, CONNECTOR 6P	M901	X-3358-212-1	MOTOR (B) ASSY
CN902	*1-564-500-11	PIN, CONNECTOR 7P	M902	X-3358-212-1	MOTOR (B) ASSY
CP1	△1-558-945-11	(W306)...CORD, POWER (POLAR.SPT-1)	Q101	8-729-900-89	TRANSISTOR DTC144ES
D191	8-719-304-32	DIODE SEL4214S	Q121	8-729-620-05	TRANSISTOR 2SC2603-EF
D192	8-719-304-32	DIODE SEL4214S	Q141	8-729-620-05	TRANSISTOR 2SC2603-EF
D193	8-719-304-32	DIODE SEL4214S	Q201	8-729-900-89	TRANSISTOR DTC144ES
D194	8-719-304-32	DIODE SEL4214S	Q221	8-729-620-05	TRANSISTOR 2SC2603-EF
D195	8-719-304-32	DIODE SEL4214S	Q241	8-729-620-05	TRANSISTOR 2SC2603-EF
D196	8-719-304-32	DIODE SEL4214S	Q321	8-729-900-89	TRANSISTOR DTC144ES
D291	8-719-304-32	DIODE SEL4214S	Q401	8-729-194-57	TRANSISTOR 2SC945-P
D292	8-719-304-32	DIODE SEL4214S	Q402	8-729-194-57	TRANSISTOR 2SC945-P
D293	8-719-304-32	DIODE SEL4214S	Q403	8-729-281-52	TRANSISTOR 2SC1815Y
D294	8-719-304-32	DIODE SEL4214S	Q404	8-729-900-65	TRANSISTOR DTA144ES
D295	8-719-304-32	DIODE SEL4214S	Q405	8-729-900-80	TRANSISTOR DTC114ES
D296	8-719-304-32	DIODE SEL4214S	Q501	8-729-900-65	TRANSISTOR DTA144ES
D401	8-719-107-94	DIODE 1SS202-1	Q502	8-729-900-65	TRANSISTOR DTA144ES
D402	8-719-107-94	DIODE 1SS202-1	Q503	8-729-900-61	(W306)...TRANSISTOR DTA114ES
D501	8-719-107-94	DIODE 1SS202-1	Q504	8-729-801-93	(W306)...TRANSISTOR 2SD1387
D504	8-719-107-94	DIODE 1SS202-1	Q505	8-729-900-89	(W306)...TRANSISTOR DTC144ES
D505	8-719-107-94	DIODE 1SS202-1	Q506	8-729-900-65	(W306)...TRANSISTOR DTA144ES
D506	8-719-107-94	DIODE 1SS202-1	Q507	8-729-900-89	TRANSISTOR DTC144ES
D507	8-719-107-94	DIODE 1SS202-1	Q508	8-729-900-80	(W306)...TRANSISTOR DTC114ES
D510	8-719-107-94	DIODE 1SS202-1	Q509	8-729-900-65	TRANSISTOR DTA144ES
D511	8-719-107-94	(W306)...DIODE 1SS202-1	Q511	8-729-900-80	(W306)...TRANSISTOR DTC114ES
D512	8-719-107-94	DIODE 1SS202-1	Q512	8-729-900-89	(W306)...TRANSISTOR DTC144ES
D513	8-719-107-94	(W306)...DIODE 1SS202-1	Q601	8-729-209-15	(W306)...TRANSISTOR 2SD2012
D514	8-719-302-46	DIODE SEL1210S-C	Q602	8-729-209-15	(W301:US,E,US,W306)..TRANSISTOR 2SD2012
D515	8-719-302-79	(W306)...DIODE SEL1910A-C	Q603	8-729-141-30	(W306)...TRANSISTOR 2SC3623A-LK
D516	8-719-107-94	DIODE 1SS202-1	Q605	8-729-620-05	(W306)...TRANSISTOR 2SC2603-EF
D517	8-719-107-94	DIODE 1SS202-1	R101	1-247-889-00	CARBON 270K 5% 1/4W
D518	8-719-107-94	DIODE 1SS202-1	R102	1-249-404-00	CARBON 82 5% 1/4W
D601	8-719-200-77	(W306)...DIODE 10E2N	R103	1-247-882-11	CARBON 130K 5% 1/4W
D602	8-719-200-77	(W306)...DIODE 10E2N	R104	1-249-426-11	CARBON 5.6K 5% 1/4W
D603	8-719-200-77	(W306)...DIODE 10E2N	R106	1-247-889-00	CARBON 270K 5% 1/4W
D604	8-719-200-77	(W306)...DIODE 10E2N	R107	1-249-404-00	CARBON 82 5% 1/4W
D605	8-719-933-33	(W306)...DIODE HZS6A1L	R108	1-247-882-11	CARBON 130K 5% 1/4W
D606	8-719-200-77	(W301)...DIODE 10E2N	R109	1-249-426-11	CARBON 5.6K 5% 1/4W
D607	8-719-200-77	(W301)...DIODE 10E2N	R110	1-249-430-11	CARBON 12K 5% 1/4W
D608	8-719-001-54	(W301:US,E,AUS,W306)...DIODE UZL-11H2	R111	1-249-431-11	CARBON 15K 5% 1/4W
HE401	1-543-673-11	HEAD, MAGNETIC (ERASE)	R112	1-247-887-00	CARBON 220K 5% 1/4W
HP101	1-543-672-11	HEAD, MAGNETIC (REC/PB)	R113	1-249-441-11	CARBON 100K 5% 1/4W
HRP101	1-543-672-11	HEAD, MAGNETIC (REC/PB)	R114	1-249-441-11	CARBON 100K 5% 1/4W
			R121	1-249-435-11	CARBON 33K 5% 1/4W
			R122	1-249-417-11	CARBON 1K 5% 1/4W

Note:

The components identified by mark △ or dotted line with mark △ are critical for safety. Replace only with part number specified.

Note:

Les composants identifiés par une marque △ sont critiques pour la sécurité. Ne les remplacer que par une pièce portant le numéro spécifié.



Ref.No.	Part No.	Description			
R129	1-249-421-11	CARBON	2.2K	5%	1/4W
R130	1-249-429-11	CARBON	10K	5%	1/4W
R131	1-249-417-11	CARBON	1K	5%	1/4W
R132	1-249-429-11	CARBON	10K	5%	1/4W
R133	1-249-421-11	CARBON	2.2K	5%	1/4W
R134	1-249-434-11	CARBON	27K	5%	1/4W
R135	1-247-842-11	CARBON	3K	5%	1/4W
R141	1-249-426-11	CARBON	5.6K	5%	1/4W
R142	1-249-421-11	CARBON	2.2K	5%	1/4W
R144	1-249-421-11	CARBON	2.2K	5%	1/4W
R145	1-249-430-11	CARBON	12K	5%	1/4W
R191	1-249-441-11	CARBON	100K	5%	1/4W
R192	1-249-405-11	CARBON	100	5%	1/4W
R201	1-247-889-00	CARBON	270K	5%	1/4W
R202	1-249-404-00	CARBON	82	5%	1/4W
R203	1-247-882-11	CARBON	130K	5%	1/4W
R204	1-249-426-11	CARBON	5.6K	5%	1/4W
R206	1-247-889-00	CARBON	270K	5%	1/4W
R207	1-249-404-00	CARBON	82	5%	1/4W
R208	1-247-882-11	CARBON	130K	5%	1/4W
R209	1-249-426-11	CARBON	5.6K	5%	1/4W
R210	1-249-430-11	CARBON	12K	5%	1/4W
R211	1-249-431-11	CARBON	15K	5%	1/4W
R212	1-247-887-00	CARBON	220K	5%	1/4W
R213	1-249-441-11	CARBON	100K	5%	1/4W
R214	1-249-441-11	CARBON	100K	5%	1/4W
R221	1-249-435-11	CARBON	33K	5%	1/4W
R222	1-249-417-11	CARBON	1K	5%	1/4W
R229	1-249-421-11	CARBON	2.2K	5%	1/4W
R230	1-249-429-11	CARBON	10K	5%	1/4W
R231	1-249-417-11	CARBON	1K	5%	1/4W
R232	1-249-429-11	CARBON	10K	5%	1/4W
R233	1-249-421-11	CARBON	2.2K	5%	1/4W
R234	1-249-434-11	CARBON	27K	5%	1/4W
R235	1-247-842-11	CARBON	3K	5%	1/4W
R241	1-249-426-11	CARBON	5.6K	5%	1/4W
R242	1-249-421-11	CARBON	2.2K	5%	1/4W
R244	1-249-421-11	CARBON	2.2K	5%	1/4W
R245	1-249-430-11	CARBON	12K	5%	1/4W
R291	1-249-441-11	CARBON	100K	5%	1/4W
R292	1-249-405-11	CARBON	100	5%	1/4W
R301	1-247-743-11	CARBON	220	5%	1/2W
R302	1-247-743-11	CARBON	220	5%	1/2W
R321	1-249-433-11	CARBON	22K	5%	1/4W
R322	1-215-460-00	METAL	43K	1%	1/6W
R323	1-247-876-11	CARBON	75K	5%	1/4W
R324	1-249-405-11	CARBON	100	5%	1/4W
R341	1-249-441-11	CARBON	100K	5%	1/4W
R342	1-247-864-11	CARBON	24K	5%	1/4W
R343	1-247-887-00	CARBON	220K	5%	1/4W
R344	1-247-882-11	CARBON	130K	5%	1/4W
R345	1-247-881-00	CARBON	120K	5%	1/4W
R346	1-249-440-11	CARBON	82K	5%	1/4W
R347	1-249-435-11	CARBON	33K	5%	1/4W
R348	1-249-438-11	CARBON	56K	5%	1/4W
R349	1-249-438-11	CARBON	56K	5%	1/4W
R350	1-247-874-11	CARBON	62K	5%	1/4W

Ref.No.	Part No.	Description			
R351	1-249-436-11	CARBON	39K	5%	1/4W
R352	1-247-874-11	CARBON	62K	5%	1/4W
R353	1-247-870-11	CARBON	43K	5%	1/4W
R354	1-249-439-11	CARBON	68K	5%	1/4W
R355	1-249-440-11	CARBON	82K	5%	1/4W
R356	1-247-876-11	CARBON	75K	5%	1/4W
R357	1-247-876-11	CARBON	75K	5%	1/4W
R358	1-249-437-11	CARBON	47K	5%	1/4W
R359	1-249-434-11	CARBON	27K	5%	1/4W
R360	1-249-438-11	CARBON	56K	5%	1/4W
R361	1-247-881-00	CARBON	120K	5%	1/4W
R362	1-249-440-11	CARBON	82K	5%	1/4W
R363	1-247-882-11	CARBON	130K	5%	1/4W
R364	1-247-872-11	CARBON	51K	5%	1/4W
R365	1-249-437-11	CARBON	47K	5%	1/4W
R366	1-249-436-11	CARBON	39K	5%	1/4W
R367	1-249-438-11	CARBON	56K	5%	1/4W
R368	1-249-439-11	CARBON	68K	5%	1/4W
R369	1-247-876-11	CARBON	75K	5%	1/4W
R370	1-249-437-11	CARBON	47K	5%	1/4W
R371	1-247-876-11	CARBON	75K	5%	1/4W
R372	1-249-438-11	CARBON	56K	5%	1/4W
R373	1-249-441-11	CARBON	100K	5%	1/4W
R374	1-247-890-11	CARBON	300K	5%	1/4W
R375	1-249-436-11	CARBON	39K	5%	1/4W
R376	1-247-881-00	CARBON	120K	5%	1/4W
R377	1-247-881-00	CARBON	120K	5%	1/4W
R378	1-247-881-00	CARBON	120K	5%	1/4W
R379	1-249-437-11	CARBON	47K	5%	1/4W
R380	1-249-437-11	CARBON	47K	5%	1/4W
R381	1-249-433-11	CARBON	22K	5%	1/4W
R391	1-249-414-11	CARBON	560	5%	1/4W
R401	1-249-393-11	CARBON	10	5%	1/4W
R402	1-249-433-11	CARBON	22K	5%	1/4W
R403	1-249-433-11	CARBON	22K	5%	1/4W
R404	1-247-858-11	CARBON	13K	5%	1/4W
R405	1-249-417-11	CARBON	1K	5%	1/4W
R406	1-249-433-11	CARBON	22K	5%	1/4W
R408	1-249-430-11	CARBON	12K	5%	1/4W
R409	1-249-426-11	CARBON	5.6K	5%	1/4W
R410	1-249-411-11	CARBON	330	5%	1/4W
R501	1-249-420-11	CARBON	1.8K	5%	1/4W
R502	1-249-408-11	CARBON	180	5%	1/4W
R503	1-249-425-11	CARBON	4.7K	5%	1/4W
R504	1-249-420-11	CARBON	1.8K	5%	1/4W
R505	1-249-408-11	CARBON	180	5%	1/4W
R506	1-249-425-11	CARBON	4.7K	5%	1/4W
R507	1-249-393-11	(W306)...CARBON	10	5%	1/4W
R509	1-249-421-11	(W306)...CARBON	2.2K	5%	1/4W
R510	1-249-427-11	CARBON	6.8K	5%	1/4W
R511	1-249-435-11	CARBON	33K	5%	1/4W
R512	1-249-440-11	CARBON	82K	5%	1/4W
R513	1-249-429-11	CARBON	10K	5%	1/4W
R514	1-249-441-11	CARBON	100K	5%	1/4W
R515	1-249-415-11	CARBON	680	5%	1/4W
R516	1-249-442-11	(W306)...CARBON	510	5%	1/4W
R517	1-249-421-11	(W306)...CARBON	2.2K	5%	1/4W

Ref.No.	Part No.	Description			
R518	1-249-417-11	(W306)...CARBON	1K	5%	1/4W
R520	1-249-425-11	CARBON	4.7K	5%	1/4W
R521	1-249-417-11	(W306)...CARBON	1K	5%	1/4W
R550	1-249-429-11	CARBON	10K	5%	1/4W
R570	1-247-848-11	(W306)...CARBON	5.1K	5%	1/4W
R603	1-249-421-11	(W306)...CARBON	2.2K	5%	1/4W
R604	1-249-421-11	(W306)...CARBON	2.2K	5%	1/4W
R605	1-249-429-11	(W306)...CARBON	10K	5%	1/4W
R606	1-249-421-11	(W306)...CARBON	2.2K	5%	1/4W
R607	1-249-421-11	(W306)...CARBON	2.2K	5%	1/4W
R608	1-249-411-11	(W301:US,E,AUS,W306) ...CARBON	330	5%	1/4W
R701	△.1-212-942-00	(W301)...FUSIBLE	2.2	5%	1/2W F
R702	1-249-417-11	(W306)...CARBON	1K	5%	1/4W
R703	1-249-421-11	(W306)...CARBON	2.2K	5%	1/4W
RV101	1-228-994-00	RES, ADJ, CARBON	10K		
RV102	1-228-994-00	RES, ADJ, CARBON	10K		
RV141	1-228-994-00	RES, ADJ, CARBON	10K		
RV201	1-228-994-00	RES, ADJ, CARBON	10K		
RV202	1-228-994-00	RES, ADJ, CARBON	10K		
RV241	1-228-994-00	RES, ADJ, CARBON	10K		
RV321	1-238-262-11	RES, VAR, CARBON	20K/20K (REC LEVEL)		
RV501	1-228-991-00	RES, ADJ, CARBON	2.2K		
RV502	1-228-990-00	RES, ADJ, CARBON	1K		
RV503	1-228-991-00	RES, ADJ, CARBON	2.2K		
RV504	1-228-990-00	RES, ADJ, CARBON	1K		
RY401	1-515-614-11	RELAY			
S301	1-571-628-11	SWITCH, SLIDE (DECK B TAPE SELECT)			
S302	1-571-627-21	SWITCH, SLIDE (DECK A TAPE SELECT)			
S303	1-571-510-11	SWITCH, PUSH (1 KEY)(DOLBY NR)			
S501	1-571-510-11	SWITCH, PUSH (1 KEY)(DUBBING SPEED)			
S601	1-570-393-21	(W306)...SWITCH, PUSH (1 KEY)(POWER)			
S902	1-571-736-11	SWITCH, LEAF (A FWD)			
S904	1-571-736-11	SWITCH, LEAF (B FWD)			
S905	1-571-736-11	SWITCH, LEAF (B REC)			
T401	1-433-303-11	TRANSFORMER, BIAS OSCILLATION			
T601	△.1-449-256-11	(W306)...TRANSFORMER, POWER			

ACCESSORY & PACKING MATERIAL

1-558-649-11	(W306)...CORD (WITH CONNECTOR) 3P
1-559-533-11	(W306)...CORD, CONNECTION
3-703-450-01	(W306)...INSTRUCTION
*3-704-343-01	SHEET (STANDARD), PROTECTION
3-751-753-21	(W306)...MANUAL, INSTRUCTION

Note:
The components identified by mark  or dotted line with mark  are critical for safety. Replace only with part number specified.

Note:
Les composants identifiés par une marque  sont critiques pour la sécurité. Ne les remplacer que par une pièce portant le numéro spécifié.

