

# TC-WA8ES/WR765S

## SERVICE MANUAL

US Model  
Canadian Model  
TC-WA8ES

AEP Model  
E Model  
Australian Model  
TC-WR765S

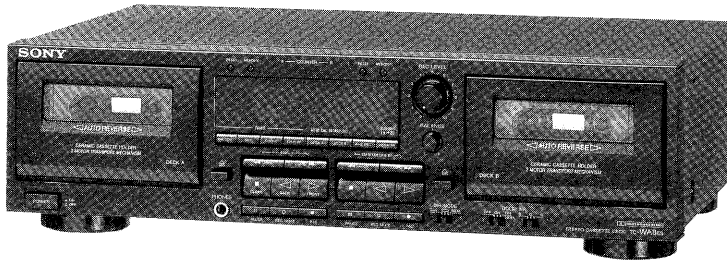

Photo : TC-WA8ES

\* Dolby noise reduction and HX Pro headroom extension manufactured under license from Dolby Laboratories Licensing Corporation. HX Pro originated by Bang & Olufsen.

"DOLBY", the double-D symbol  $\square\square$  and "HX PRO" are trademarks of Dolby Laboratories Licensing Corporation.

Model Name Using Similar Mechanism	TC-WR545/WR741
Tape Transport Mechanism Type	TCM-190RB12CL

### SPECIFICATIONS

Recording system 4-track 2-channel stereo  
Fastwinding time Approx. 90 sec. (with Sony C-60 cassette)  
Bias AC bias  
Signal-to-noise ratio (at peak level and weighted)

Cassette (Dolby NR OFF)	Type IV	Type II	Type I
	58 dB	57 dB	55 dB

S/N ratio improved (approximate values)  
with Dolby B NR on: 5 dB at 1 kHz; 10 dB at 5 kHz  
with Dolby C NR on: 15 dB at 500 Hz; 20 dB at 1 kHz  
with Dolby S NR on: 10 dB at 100 Hz; 24 dB at 1 kHz

Harmonic distortion  
0.4% (with Sony Type I, 160 nWb/m, 315 Hz, 3rd H.D.)  
1.8% (with Sony Type IV, 250 nWb/m, 315 Hz, 3rd H.D.)

Frequency response (Dolby NR OFF)

Cassette Model	Type IV cassette	Type II cassette	Type I cassette
TC-WA8ES/WR765S	30 - 18,000 Hz ( $\pm 3$ dB, IEC) 30 - 13,000 Hz [ $\pm 3$ dB (-4 dB) recording]	30 - 17,000 Hz ( $\pm 3$ dB, IEC)	30 - 15,000 Hz ( $\pm 3$ dB, IEC)

Type IV: Sony Type IV (METAL)  
Type II: Sony Type II (HIGH)  
Type I: Sony Type I (NORMAL)

Wow and flutter  $\pm 0.13\%$  W.Peak (IEC)  
0.07% W.RMS (NAB)  
 $\pm 0.18\%$  W.Peak (DIN)

Inputs

Line inputs (phono jacks)	Sensitivity	0.16 V
	Input impedance	47 k ohms

Outputs

Line outputs (phono jacks)	Rated output level	0.5 V at a load impedance of 47 k ohms
	Load impedance	Over 10 k ohms
Headphones (stereo phone jack)	Output level	1 mW at a load impedance of 32 ohms

- Continued on page 2 -



STEREO CASSETTE DECK  
**SONY**®

**General**

Power requirements

Where purchased	Power requirements
US, Canadian model	120V AC, 60Hz
AEP, German model	220 – 230V AC, 50/60Hz
Australian model	240V AC, 50/60Hz
E model	120/220/240V AC, 50/60Hz

Power consumption 28 W

Dimensions

US, Canadian model :  
 Approx. 430 × 123 × 290 mm  
 (w/h/d)  
 (17 × 4 7/8 × 11 1/2 inches)  
 AEP, German, E, Australian model :  
 Approx. 430 × 123 × 300 mm  
 (w/h/d)  
 (17 × 4 7/8 × 11 7/8 inches)  
 including projecting parts and  
 controls

Mass Approx. 4.6 kg (10 lbs 3 oz)

**Supplied accessories**

Audio connecting cords (2)

Design and specifications are subject to change without notice.

**TABLE OF CONTENTS**

<i>Section</i>	<i>Title</i>	<i>Page</i>
Specifications	.....	1
Safety Check-out	.....	3
<b>1. GENERAL</b>		
1-1. Identifying the Parts on the Front Panel	.....	4
<b>2. DISASSEMBLY</b>		
2-1. Front Panel	.....	5
2-2. Mechanism Deck	.....	5
2-3. Capstan Motor, Reel Motor	.....	6
2-4. Head, Pinch Roller	.....	6
<b>3. ADJUSTMENTS</b>		
3-1. Mechanical Adjustments	.....	7
3-2. Electrical Adjustments	.....	7
<b>4. EXPLANATION OF IC TERMINALS</b>	.....	11
<b>5. DIAGRAMS</b>		
5-1. Block Diagram	.....	14
5-2. Circuit Board Location	.....	16
5-3. Printed Wiring Boards (Main Section)	.....	17
5-4. Schematic Diagram (Main Section)	.....	21
5-5. Schematic Diagram (Audio Section)	.....	26
5-6. Printed Wiring Boards (Audio Section)	.....	31
5-7. Printed Wiring Boards (Dolby (S) Section)	.....	34
5-8. Schematic Diagram (Dolby (S) Section)	.....	34
<b>6. EXPLODED VIEWS</b>		
6-1. Chassis Section	.....	37
6-2. Front Panel Section	.....	38
6-3. Mechanism Section 1	.....	39
6-4. Mechanism Section 2	.....	40
<b>7. ELECTRICAL PARTS LIST</b>	.....	41

**MODEL IDENTIFICATION**  
*(Specification Label)*

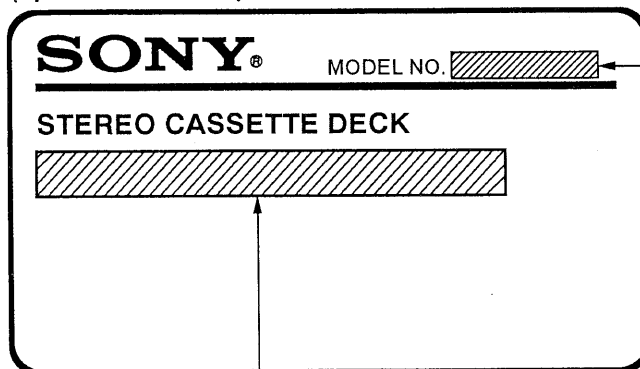

TC-WA8ES  
 TC-WR765S

US, Canadian model : AC 120V 60Hz  
 Australian model : AC 240V~50/60Hz  
 AEP, German model : AC 220-230V~50/60Hz  
 E model : AC120, 220, 240V~50/60Hz

## SAFETY CHECK-OUT

After correcting the original service problem, perform the following safety check before releasing the set to the customer:

Check the antenna terminals, metal trim, "metallized" knobs, screws, and all other exposed metal parts for AC leakage. Check leakage as described below.

### LEAKAGE TEST

The AC leakage from any exposed metal part to earth ground and from all exposed metal parts to any exposed metal part having a return to chassis, must not exceed 0.5 mA (500 microamperes). Leakage current can be measured by any one of three methods.

1. A commercial leakage tester, such as the Simpson 229 or RCA WT-540A. Follow the manufacturers' instructions to use these instruments.
2. A battery-operated AC milliammeter. The Data Precision 245 digital multimeter is suitable for this job.

3. Measuring the voltage drop across a resistor by means of a VOM or battery-operated AC voltmeter. The "limit" indication is 0.75 V, so analog meters must have an accurate low-voltage scale. The Simpson 250 and Sanwa SH-63Trd are examples of a passive VOM that is suitable. Nearly all battery operated digital multimeters that have a 2V AC range are suitable. (See Fig. A)

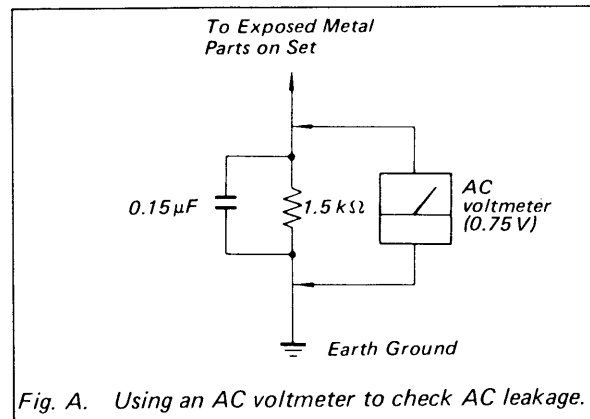

Fig. A. Using an AC voltmeter to check AC leakage.

### SAFETY-RELATED COMPONENT WARNING!!

COMPONENTS IDENTIFIED BY MARK  $\triangle$  OR DOTTED LINE WITH MARK  $\triangle$  ON THE SCHEMATIC DIAGRAMS AND IN THE PARTS LIST ARE CRITICAL TO SAFE OPERATION. REPLACE THESE COMPONENTS WITH SONY PARTS WHOSE PART NUMBERS APPEAR AS SHOWN IN THIS MANUAL OR IN SUPPLEMENTS PUBLISHED BY SONY.

### ATTENTION AU COMPOSANT AYANT RAPPORT À LA SÉCURITÉ!

LES COMPOSANTS IDENTIFIÉS PAR UNE MARQUE  $\triangle$  SUR LES DIAGRAMMES SCHÉMATIQUES ET LA LISTE DES PIÈCES SONT CRITIQUES POUR LA SÉCURITÉ DE FONCTIONNEMENT. NE REMPLACER CES COMPOSANTS QUE PAR DES PIÈCES SONY DONT LES NUMÉROS SONT DONNÉS DANS CE MANUEL OU DANS LES SUPPLÉMENTS PUBLIÉS PAR SONY.



## SECTION 1 GENERAL

This section is extracted from instruction manual.

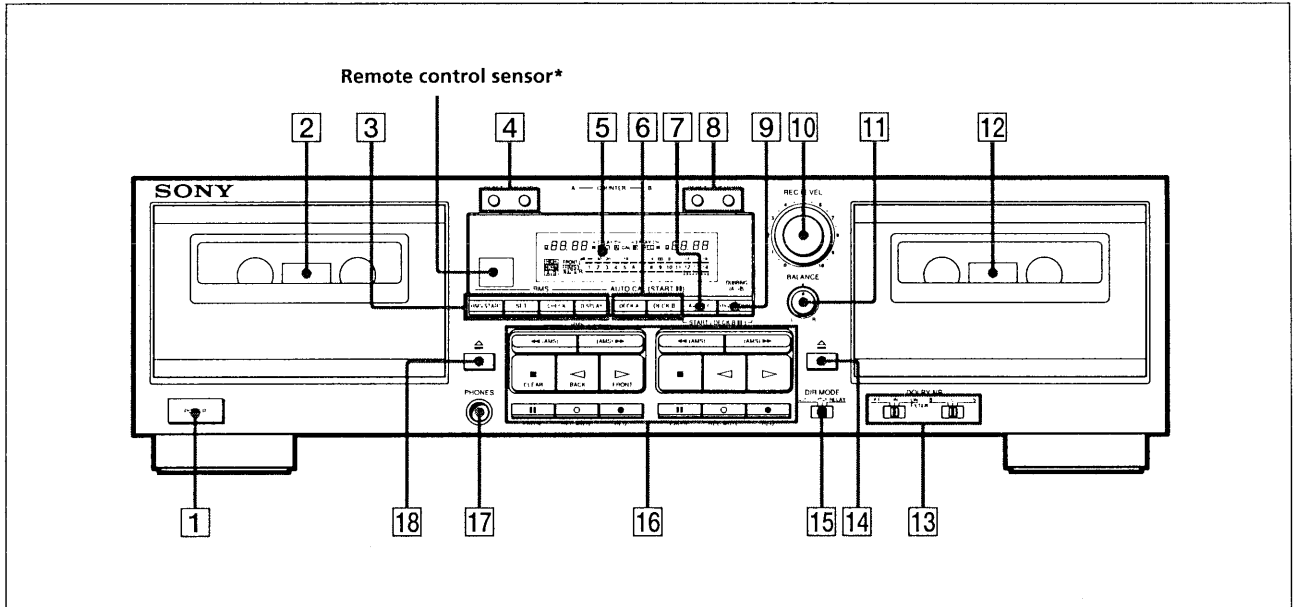
# Identifying the Parts on the Front Panel



For details, refer to the page number(s) indicated in parentheses.

- |  |  |
|--|--|
| <p><b>1</b> POWER switch</p> <p><b>2</b> Deck A</p> <p><b>3</b> RMS** operation buttons<br/>RMS/START button<br/>SET button<br/>CHECK button<br/>DISPLAY button</p> <p><b>4</b> COUNTER buttons (deck A)<br/>RESET button<br/>MEMORY button</p> <p><b>5</b> Display panel</p> <p><b>6</b> AUTO CAL DECK A and DECK B buttons</p> <p><b>7</b> A+B REC button</p> <p><b>8</b> COUNTER buttons (deck B)<br/>RESET button<br/>MEMORY button</p> <p><b>9</b> DUBBING HIGH/NORM button</p> <p><b>10</b> REC (recording) LEVEL control</p> <p><b>11</b> BALANCE control</p> <p><b>12</b> Deck B</p> <p><b>13</b> DOLBY NR switches<br/>OFF/ON/FILTER ON switch<br/>B/C/S switch</p> | <p><b>14</b> ≡ (eject) button (deck B)</p> <p><b>15</b> DIR (direction) MODE switch</p> <p><b>16</b> Tape operation buttons<br/>◀◀ (leftward fastwinding)/AMS**/RMS**<sup>-</sup> button<br/>▶▶ (rightward fastwinding)/AMS**/RMS**<sup>+</sup> button<br/>■ (stop)/(RMS**) CLEAR button<br/>◁ (reverse play)/(RMS**) BACK button<br/>▷ (forward play)/(RMS**) FRONT button<br/>   PAUSE button<br/>○ REC MUTE (record muting) button<br/>● REC (recording) button</p> <p><b>17</b> PHONES jack (stereo phone jack)</p> <p><b>18</b> ≡ (eject) button (deck A)</p> <p>* Remote control sensor<br/>You can remotely control this cassette deck with:<br/>— A remote commander that came with a Sony amplifier or receiver if it has the  mark and cassette deck control capability.<br/>— Any optional Sony remote commander with the  mark and cassette deck control capability.</p> <p>** Random Music Sensor</p> <p>*** Automatic Music Sensor</p> |
|--|--|

## SECTION 2 DISASSEMBLY

Note : Follow the disassembly procedure in the numerical order given.

**CASE**  
Unscrew the four case attachment screws M3 × 8 and remove the case.

### 2-1. FRONT PANEL

FRONT PANEL ① - ③  
VOLTAGE SELECTOR ① - ②

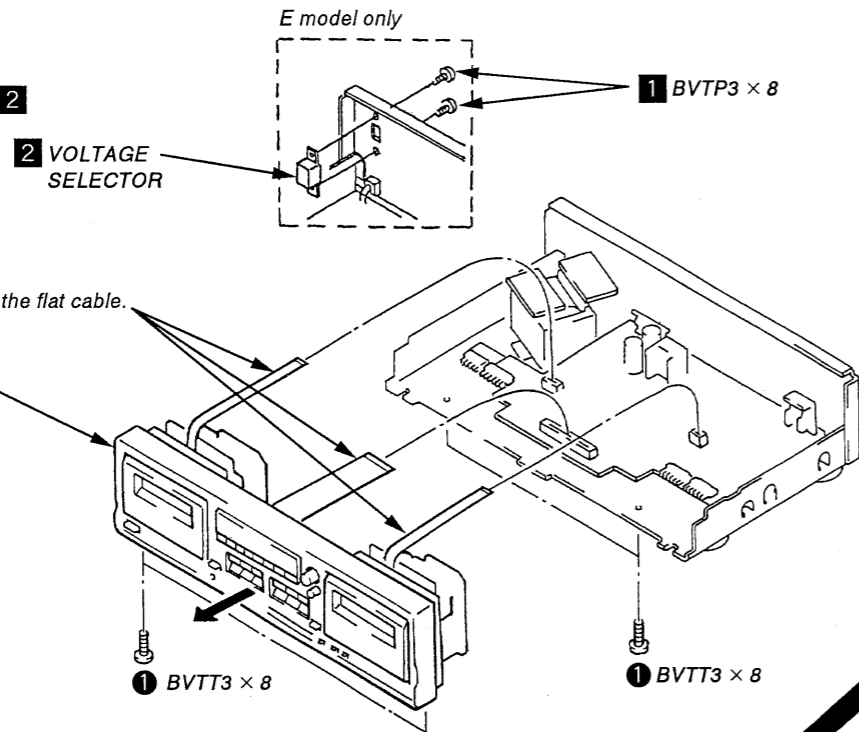

### 2-2. MECHANISM DECK

① Press the EJECT button.

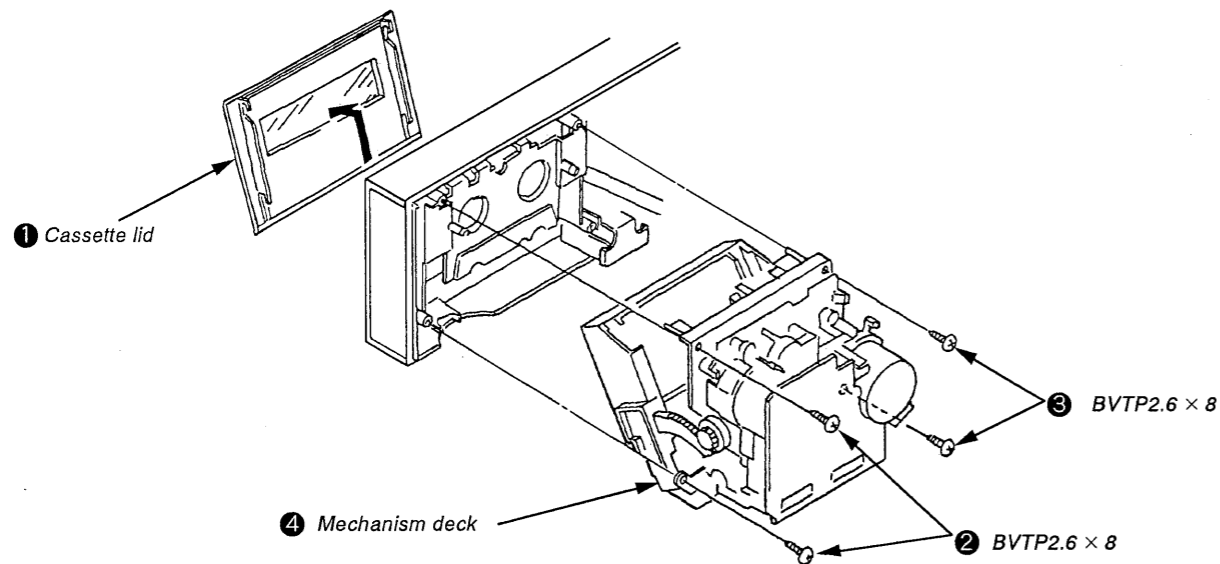

### 2-3. CAPSTAN MOTOR, REEL MOTOR

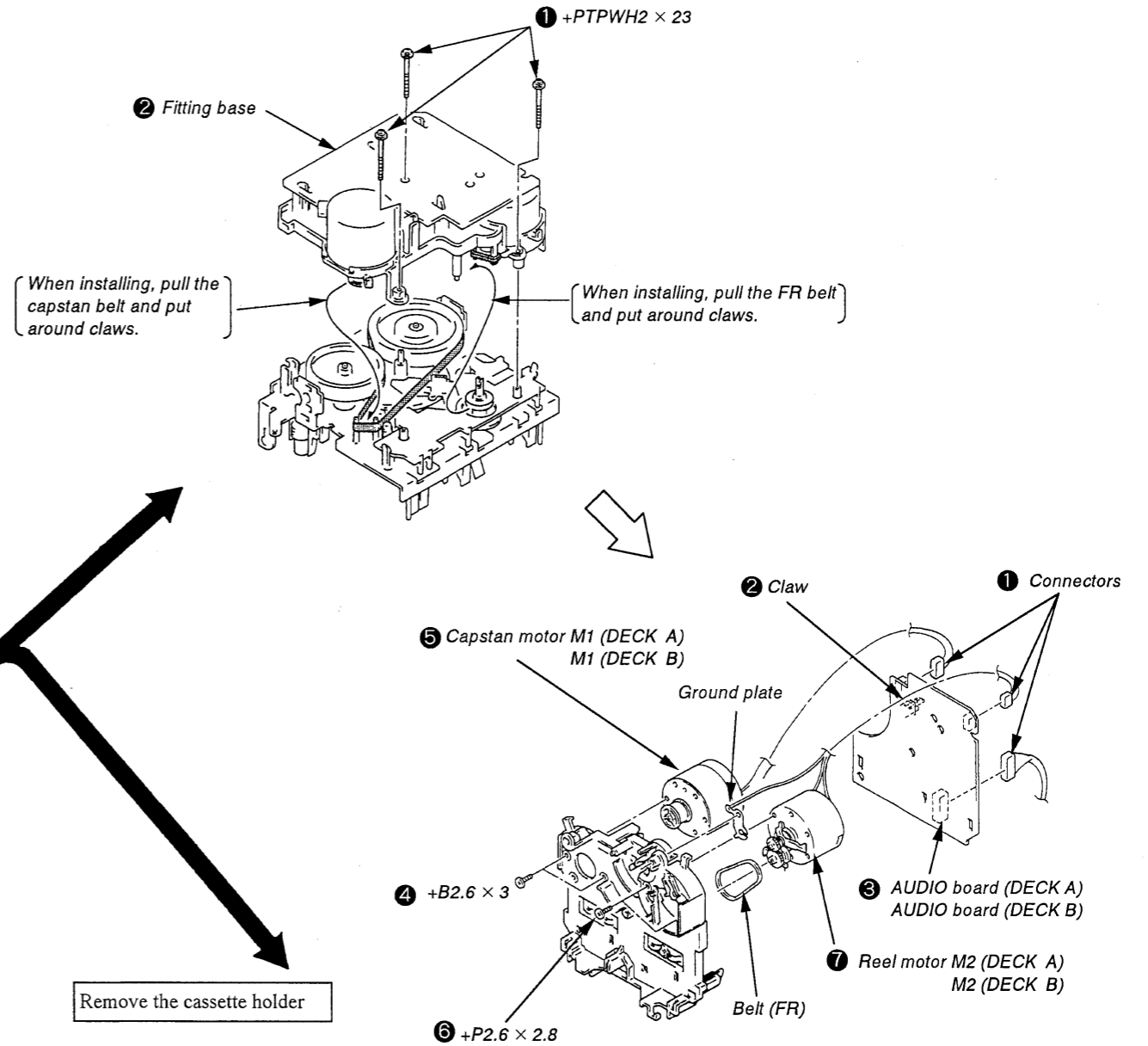

### 2-4. HEAD, PINCH ROLLER

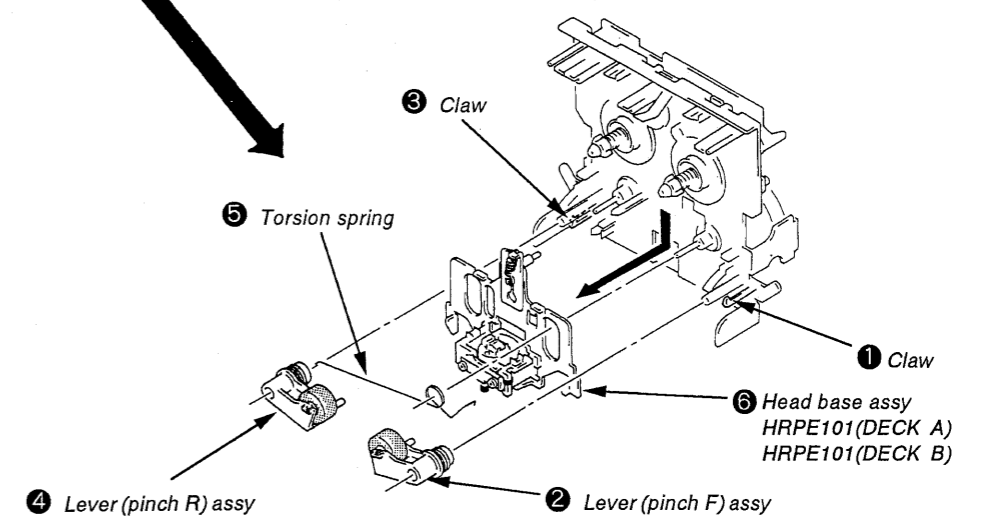

## SECTION 3 ADJUSTMENTS

### 3-1. MECHANICAL ADJUSTMENTS

#### PRECAUTION

1. Clean the following parts with a denatured alcohol-moistened swab:
 

record/playback/erase head	pinch roller
rubber belts	capstan
idlers	
2. Demagnetize the record/playback head with a head demagnetizer.
3. Do not use a magnetized screwdriver for the adjustment.
4. After the adjustments, apply suitable locking compound to the parts adjusted.
5. The adjustments should be performed with the rated power supply voltage unless otherwise noted.

#### Torque Measurement

Torque	Torque meter	Meter reading
Forward	CQ-102C	30 to 65g • cm (0.42 to 0.9 oz • inch)
Forward back tension	CQ-102C	DECK A : 1 to 6g • cm (0.014 to 0.083 oz • inch) DECK B : 2 to 9g • cm (0.03 to 0.12 oz • inch)
Reverse	CQ-102RC	30 to 65g • cm (0.42 to 0.9 oz • inch)
Reverse back tension	CQ-102RC	1 to 6g • cm (0.014 to 0.083 oz • inch)
FF/REW	CQ-201B	70 to 120g • cm (0.98 to 1.66 oz • inch)

### 3-2. ELECTRICAL ADJUSTMENTS

#### PRECAUTION

1. The adjustment should be performed in the publication.  
(Be sure to make playback adjustment at first.)
2. The adjustments and measurement should be performed for both L-CH and R-CH.
  - Switch position
 

DOLBY NR switch	: OFF
DIR MODE switch	: ⇄
  - Standard record position :
 

Deliver the standard input signal level to input jack and set the REC LEVEL control to obtain the standard output signal level as follows.

— Record Mode —

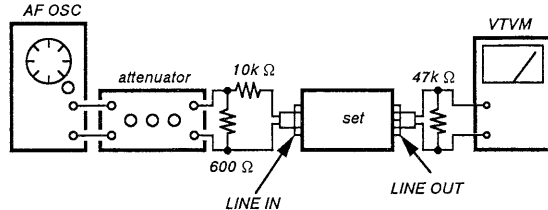

#### Standard Input Level

Input terminal	LINE IN
source impedance	10k Ω
input signal level	0.5V ( - 3.8dB)

#### Standard Output Level

Output terminal	LINE OUT
load impedance	47k Ω
output signal level	0.5V ( - 3.8dB)

#### Test Tape

Tape	Contents	Use
P-4-A100	10kHz, - 10dB	Azimuth Adjustment
P-4-L300	315Hz, 0dB	PB Level Adjustment
WS-48B	3kHz, 0dB	Tape Speed Adjustment

0dB=0.775V

#### Test Mode

1. Insert a short-circuit plug into TP801 (2P) and turn ON the power switch.  
At first, all the fluorescent tubes light up, then the system returns to normal display. (However, "0000" is not displayed on the counter.)
2. To release the test mode, remove the short plug and turn off the power switch.
3. Remove the short plug after completion of adjustment.

#### Record/Playback Head Azimuth Adjustment Procedure :

1. Forward playback Mode

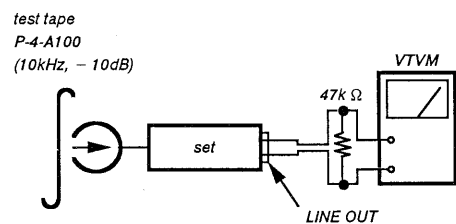

2. Turn the adjustment screw for the maximum output levels. If these levels do not match, turn the adjustment screw until both of output levels match together within 1dB.

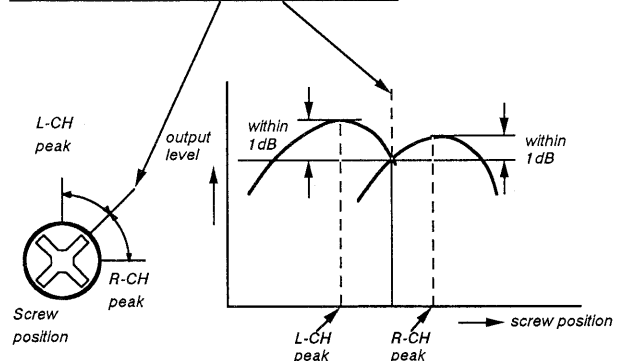

### 3. Playback Mode

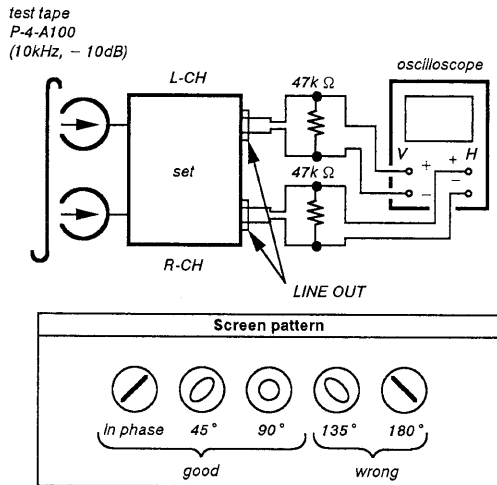

4. Change the reverse playback mode and repeat the steps 1 to 3.
5. After the adjustment, lock the adjustment screws with suitable locking compound.

**Adjustment Location :** – record/playback head –

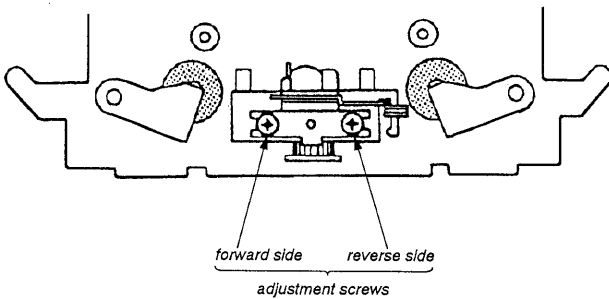

### Tape Speed Adjustment

#### Procedure :

– Forward Playback Mode –

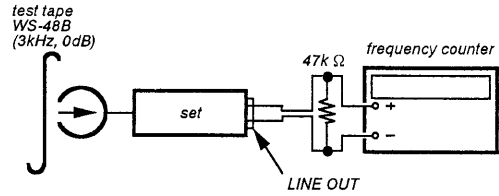

(High speed adjustment)

1. Set to test mode. (Refer to page 7)
2. Set to FWD playback mode.
3. Keep on pressing the HIGH SPEED DUBBING switch.
4. Adjust RV72 so that the frequency counter reading becomes  $6,000 \pm 20\text{Hz}$ .
5. Release test mode after adjustment is completed.

(Normal speed adjustment)

1. Set to FWD playback mode.
2. Adjust RV71 so that the frequency counter reading becomes  $3,000 \pm 10\text{Hz}$ .

Frequency difference between the beginning and the end of the tape should be within 3%.

Frequency difference between the deck A and deck B the beginning of the tape should be within 1.5%.

**Adjustment Location :** AUDIO board. (See page 10)

### Playback Level Adjustment

#### Procedure :

– Forward Playback Mode –

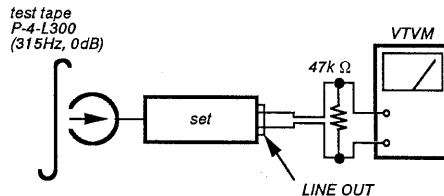

Adjust RV11(L-CH) and RV21(R-CH) so the VTVM reading becomes the adjustment limits below.

#### Adjustment Value :

LINE OUT level : –  $7.7 \pm 0.5\text{dB}$  (0.301 to 0.338V)

Level difference between channels : within 0.5dB

Confirm the LINE OUT level does not change in playback mode while changing the mode from playback to stop several times.

**Adjustment Location :** AUDIO board. (See page 10)

## Bias Consumption Current Adjustment

This adjustment should be performed when replacing the head assy or the bias oscillating transformer (T81, T91).

### Procedure :

( ) : R-CH

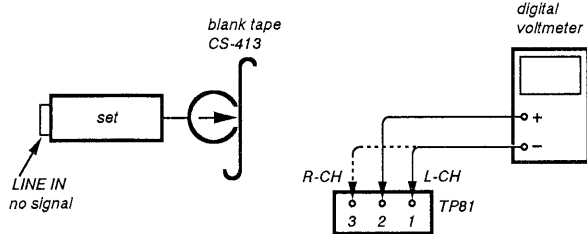

1. Connect the digital voltmeter to test point TP81.
2. Set RV81 (RV91) to mechanical center.
3. Set to FWD record mode.
4. Adjust T81 (T91) so that the digital voltmeter reading becomes minimum.

**Adjustment Value :** Maximum 220mV

**Adjustment Location :** AUDIO board. (See page 10)

## Record Bias Adjustment

### Setting :

REC LEVEL control : standard record position (Refer to page 7.)

### Procedure :

1. Record Mode

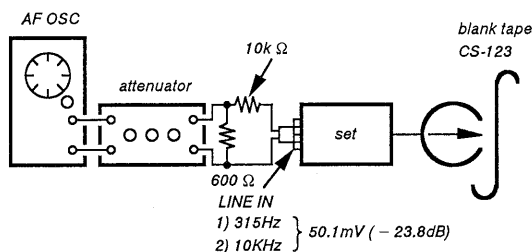

2. Playback Mode

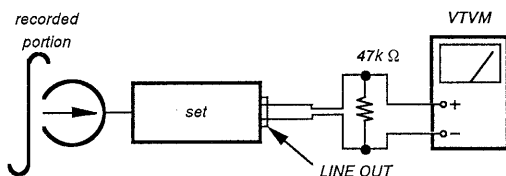

Confirm that the 10kHz playback output is  $0 \pm 0.5\text{dB}$  relative to the 315Hz output. If necessary, adjust RV81 (L-CH), RV91(R-CH) and repeat the steps given above.

**Adjustment Location :** AUDIO board. (See page 10)

## Record Level Adjustment

### Setting :

REC LEVEL control : standard record position (Refer to page 7.)

### Procedure :

1. Record Mode

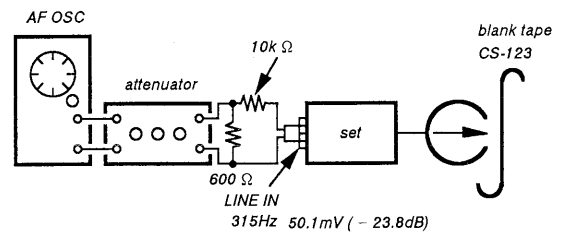

2. Playback Mode

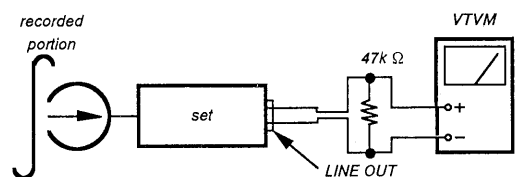

Confirm playback the tape recorded become adjustment level as follows.

If necessary, adjust RV101 (DECK B, L-CH), RV201 (DECK B, R-CH), RV102 (DECK A, L-CH), RV202 (DECK A, R-CH) and repeat the steps 1 and 2.

### Adjustment Value :

LINE OUT level :  $-23.8 \pm 0.5\text{dB}$  (47.2 to 53mV)

**Adjustment Location :** MAIN board. (See page 10)



— Adjustment Parts Location Diagrams —

**[MAIN BOARD]**

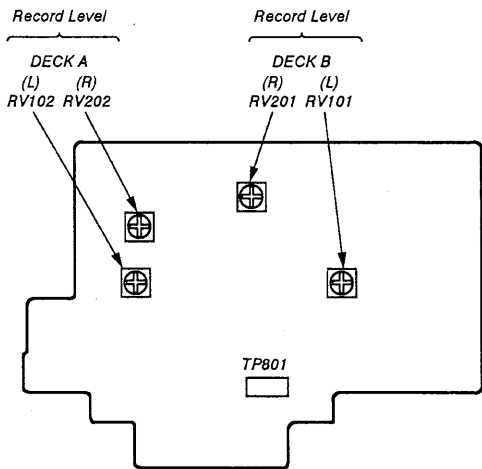

DECK A, DECK B :  
**[AUDIO BOARD]**

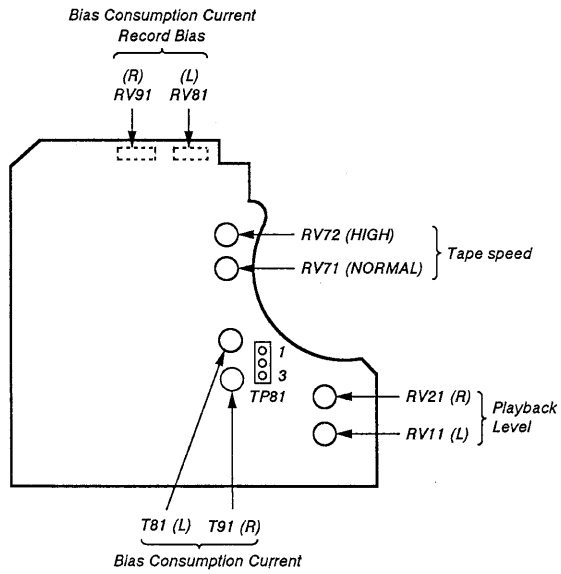

## SECTION 4 EXPLANATION OF IC TERMINALS

### IC801 CXP82220-031Q

Pin No.	Pin name	I/O	Description
1	IV (A)	I	METAL tape selector terminal.
2	IV (B)	I	METAL tape selector terminal.
3	70/120 $\mu$ (A)	I	70/120 $\mu$ tape selector terminal.
4	SIRCS	I	SIRCS signal input terminal.
5	70/120 $\mu$ (B)	I	70/120 $\mu$ tape selector terminal.
6	A/B SEL	O	Playback A/B selector.
7	NC	-	Not used. (OPEN)
8	POWER OUT	O	Power ON/OFF.
9	POWER IN	I	Power OFF. OFF=0V
10	REC MUTE (A)	O	Recording mute ON/OFF. "L" : ON
11	REC CAL 0 (A)	O	Recording calibration UP/DOWN. "H" : UP, "HIGH IMPEDANCE" : OFF, "L" : DOWN
12	REC CAL 1 (A)	O	Recording calibration UP/DOWN. "H" : UP, "HIGH IMPEDANCE" : OFF, "L" : DOWN
13	GP CAL 0 (A)	O	GEQ calibration UP/DOWN. "H" : UP, "HIGH IMPEDANCE" : OFF, "L" : DOWN
14	GP CAL 1 (A)	O	GEQ calibration UP/DOWN. "H" : UP, "HIGH IMPEDANCE" : OFF, "L" : DOWN
15	REC/PB	O	Recording/playback select. "L" : Playback
16	DIR SW (A)	I	DIRECTION SW (A) input terminal.
17	PB EQ HIGH/NORM	O	Playback EQ high/normal select.
18	REC MUTE (B)	O	Recording mute ON/OFF control. "L" : ON
19	REC CAL 0 (B)	O	Recording calibration UP/DOWN. "H" : UP, "HIGH IMPEDANCE" : OFF, "L" : DOWN
20	REC CAL 1 (B)	O	Recording calibration UP/DOWN. "H" : UP, "HIGH IMPEDANCE" : OFF, "L" : DOWN
21	GP CAL 0 (B)	O	GEQ calibration ON/OFF.
22	GP CAL 1 (B)	O	GEQ calibration ON/OFF.
23	CAL/OFF/S	O	CAL/OFF • B • C/S selector.
24	C/B/OFF	O	DOLBY C/B/OFF selector.
25	METER MUTE ON/OFF	-	Not used. (OPEN)
26	PASS/MUTE/DOLBY	O	DOLBY/MUTE/PASS selector.
27	BS/AMS/OFF	O	BS/AMS/OFF selector.
28	RELAY (B)	O	Recording/playback selector.
29	BIAS (B)	O	BIAS ON/OFF at DECK B. "H" : ON
30	AD CONT 0	O	A/D converter analog switch control.
31	AD CONT 1	O	A/D converter analog switch control.
32	A/D IN 0	I	A/D converter analog input.
33	A/D IN 1	I	A/D converter analog input.
34	S • REEL (A)	I	S-Side reel rotation detection at DECK A.
35	S • REEL (B)	I	S-Side reel rotation detection at DECK B.
36	AMS IN	I	AMS signal input terminal.
37	KEY 5	I	Key 5 input terminal.
38	RESET	I	System reset terminal.
39	EXTAL	O	System clock output terminal. (10MHz)
40	XTAL	I	System clock input terminal. (10MHz)

Note :  $\overline{\text{O O O}}$  : L active  
 $\overline{\text{O O O}}$  : HIGH IMPEDANCE active

Pin No.	Pin name	I/O	Description
41	V <sub>ss</sub>	–	Power supply. (GND)
42	TX	–	Not used. (GND)
43	TEX	–	Not used. (GND)
44	TEST	I	Test mode terminal. “L” : Test mode
45	NC	–	Not used. (GND)
46	AVREF	–	Analog voltage reference terminal.
47	AV <sub>ss</sub>	–	Analog power supply. (GND)
48	LINE MUTE	O	Line mute ON/OFF. “L” : ON
49	OSC H/L	O	CAL tone OSC H/L control. “H” : 400Hz, HIGH IMPEDANCE : 10kHz
50	OSC ON/OFF	O	CAL tone OSC ON/OFF control. “H” : OFF, HIGH IMPEDANCE : ON
51	BIAS CAL 0 (B)	O	EQ BIAS calibration terminal. (DECK B)
52	BIAS CAL 1 (B)	O	EQ BIAS calibration terminal. (DECK B)
53	BIAS CAL 2 (B)	O	EQ BIAS calibration terminal. (DECK B)
54	BIAS CAL 3 (B)	O	EQ BIAS calibration terminal. (DECK B)
55	BIAS CAL 0 (A)	O	EQ BIAS calibration terminal. (DECK A)
56	BIAS CAL 1 (A)	O	EQ BIAS calibration terminal. (DECK A)
57	BIAS CAL 2 (A)	O	EQ BIAS calibration terminal. (DECK A)
58	BIAS CAL 3 (A)	O	EQ BIAS calibration terminal. (DECK A)
59	CAP •M (B)	O	Capstan motor output at DECK B.
60	CAP •M (A)	O	Capstan motor output at DECK A.
61	CAP •M H/L	O	Capstan motor speed control.
62	P16	O	VFD Segment drive.
63	P15		
64	P14		
65	P13		
66	P12		
67	P11		
68	P10		
69	P9		
70	P8		
71	P7		
72	P6		
73	P5		
74	P4		
75	P3		
76	P2		
77	P1		
78	G1	O	VFD Grid drive.
79	G2		
80	G3		

Pin No.	Pin name	I/O	Description
81	G4	O	VFD Grid drive.
82	G5		
83	G6		
84	G7		
85	G8		
86	G6, G7		
87	G7, G8		
88	VFDP	-	VFD power. ( - 29V)
89	VDD	-	Power supply. (+5V)
90	NC	-	Not used. (VDD)
91	Vss	-	Power supply. (GND)
92	REEL (A) +	-	Reel motor (+) output at DECK A.
93	REEL (A) -	O	Reel motor ( - ) output at DECK A.
94	REEL (B) +	O	Reel motor (+) output at DECK B.
95	REEL (B) -	O	Reel motor ( - ) output at DECK A.
96	BIAS (A)	O	BIAS ON/OFF at DECK A. "H" : ON
97	RELAY (A)	O	Recording/playback selector.
98	DIR SW (B)	I	DIRECTION SW (B) input terminal.
99	STOP SW (B)	I	Mechanism stop switch for DECK B.
100	STOP SW (A)	I	Mechanism stop switch for DECK A.

SECTION 5  
DIAGRAMS

5-1. BLOCK DIAGRAM

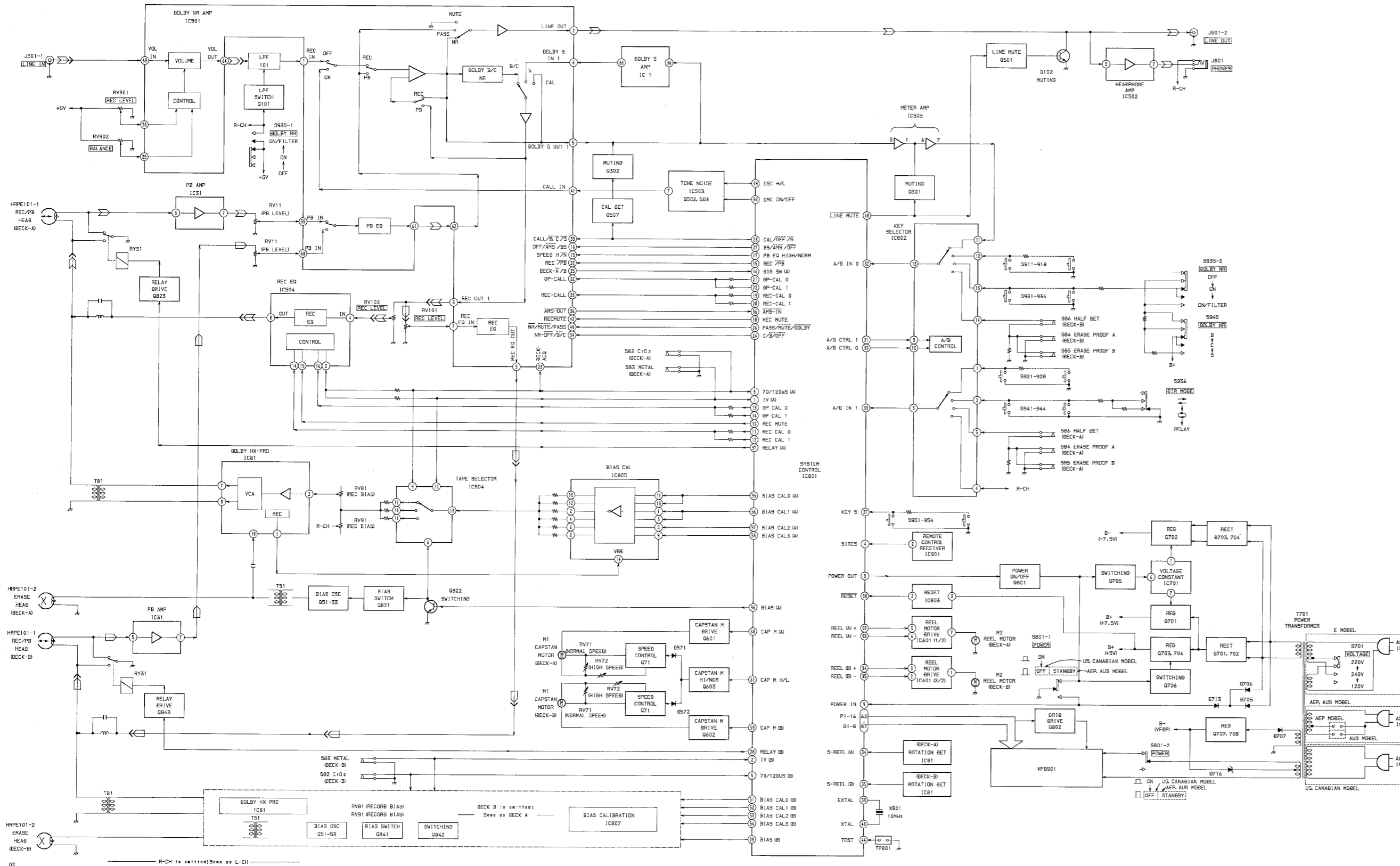

02

5-2. CIRCUIT BOARD LOCATION

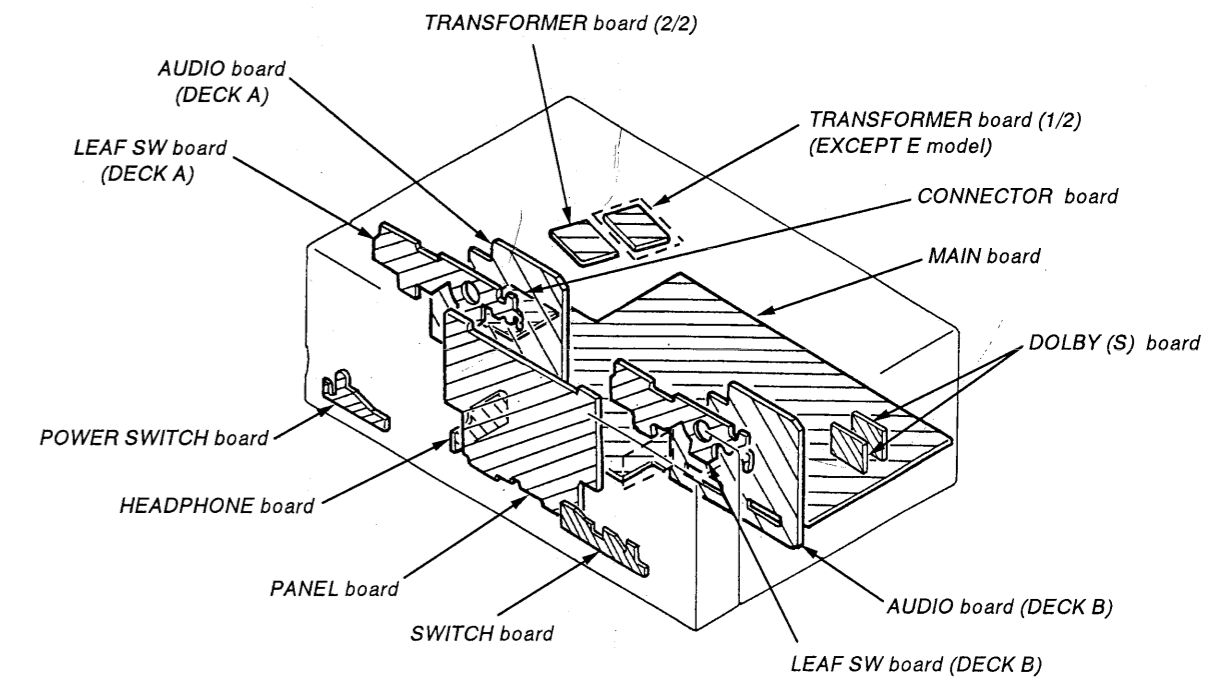

- Signal path.
- ▷ : PB ( DECK A )
- ▷▷ : REC ( DECK A )
- ▷ : PB ( DECK B )
- ▷▷ : REC ( DECK B )

● SEMICONDUCTOR LOCATION

Ref. No.	Location	Ref. No.	Location
D151	G-7	IC803	G-7
D251	H-7	IC804	G-13
D301	F-4	IC805	G-12
D302	F-4	IC806	H-4
D401	E-4	IC807	H-4
D402	F-4	IC901	H-18
D501	B-2		
D502	B-2		
D504	C-2	Q101	E-4
D505	C-2	Q102	B-5
		Q201	C-4
		Q202	B-5
		Q301	F-2
D506	C-2		
D507	C-2		
D571	H-13		
D572	H-3	Q302	F-2
D701	B-12	Q401	E-2
		Q402	E-3
		Q501	B-6
		Q502	B-2
D702	B-12		
D703	C-12	Q503	B-2
D704	C-12	Q507	F-2
D705	B-12	Q801	I-12
D706	B-13	Q602	I-12
		Q803	I-12
D707	D-12		
D708	B-9	Q701	A-11
D709	B-9	Q702	C-10
D710	B-10	Q703	A-12
D711	C-10	Q704	B-12
		Q705	B-10
D712	B-12		
D713	B-12		
D714	D-11		
D715	C-11	Q706	B-11
D716	D-12	Q707	D-11
		Q708	D-11
		Q801	F-11
D717	B-11	Q802	J-10
D718	E-8		
D801	I-10		
D802	I-10	Q821	G-14
D803	I-9	Q822	G-14
		Q823	F-14
		Q841	G-3
		Q842	G-4
D804	I-9		
		Q843	G-3
IC501	D-6		
IC502	B-7		
IC503	B-2		
IC504	E-11		
IC505	F-3		
IC506	F-4		
IC601	H-11		
IC701	B-10		
IC801	H-8		
IC802	G-7		

Note:

- — : parts extracted from the component side.
- ⊙ : Pattern on the side which is seen.
- Abbreviation : German  
G : German  
AUS : Australian

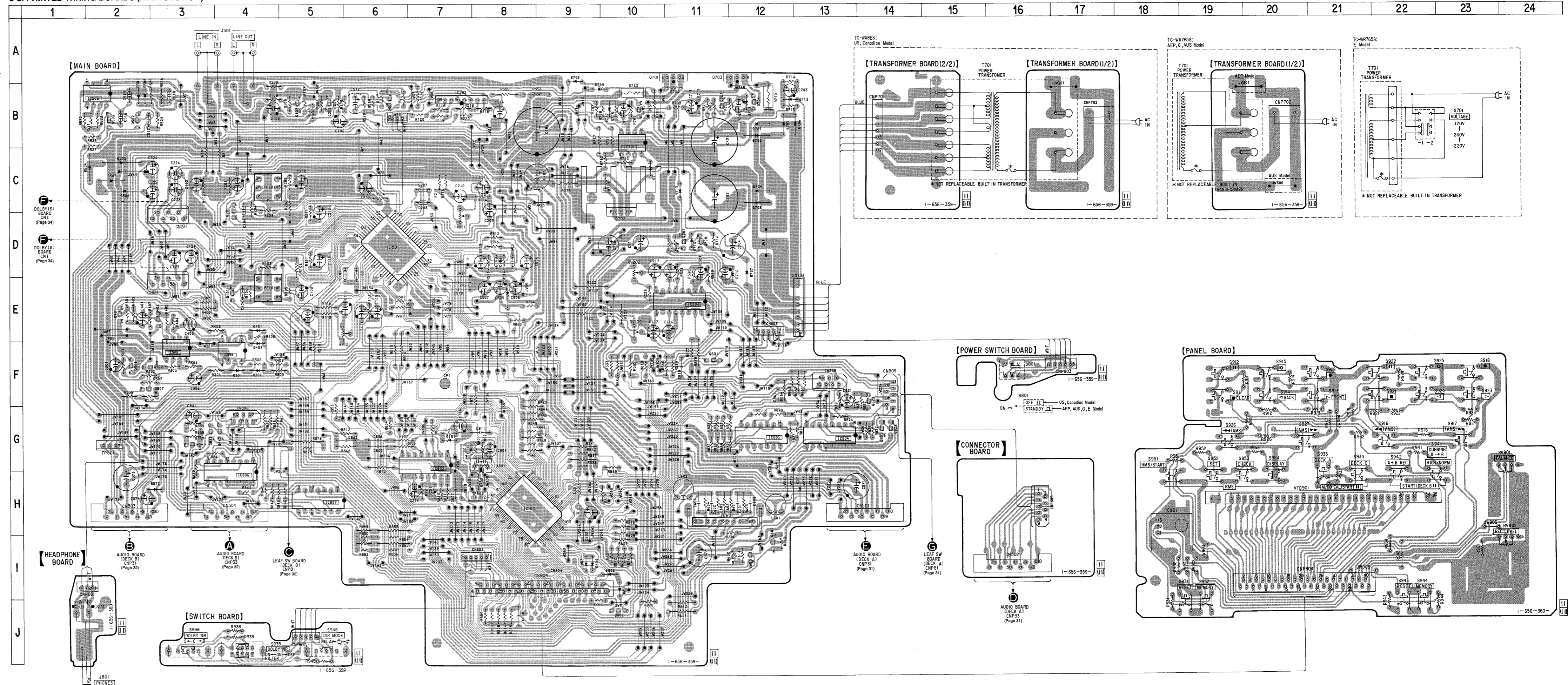

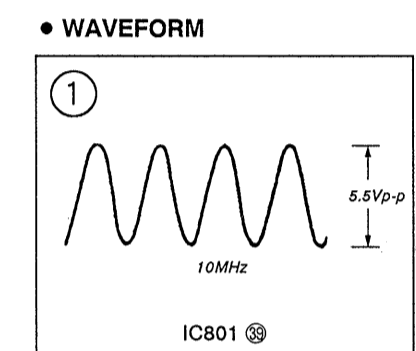
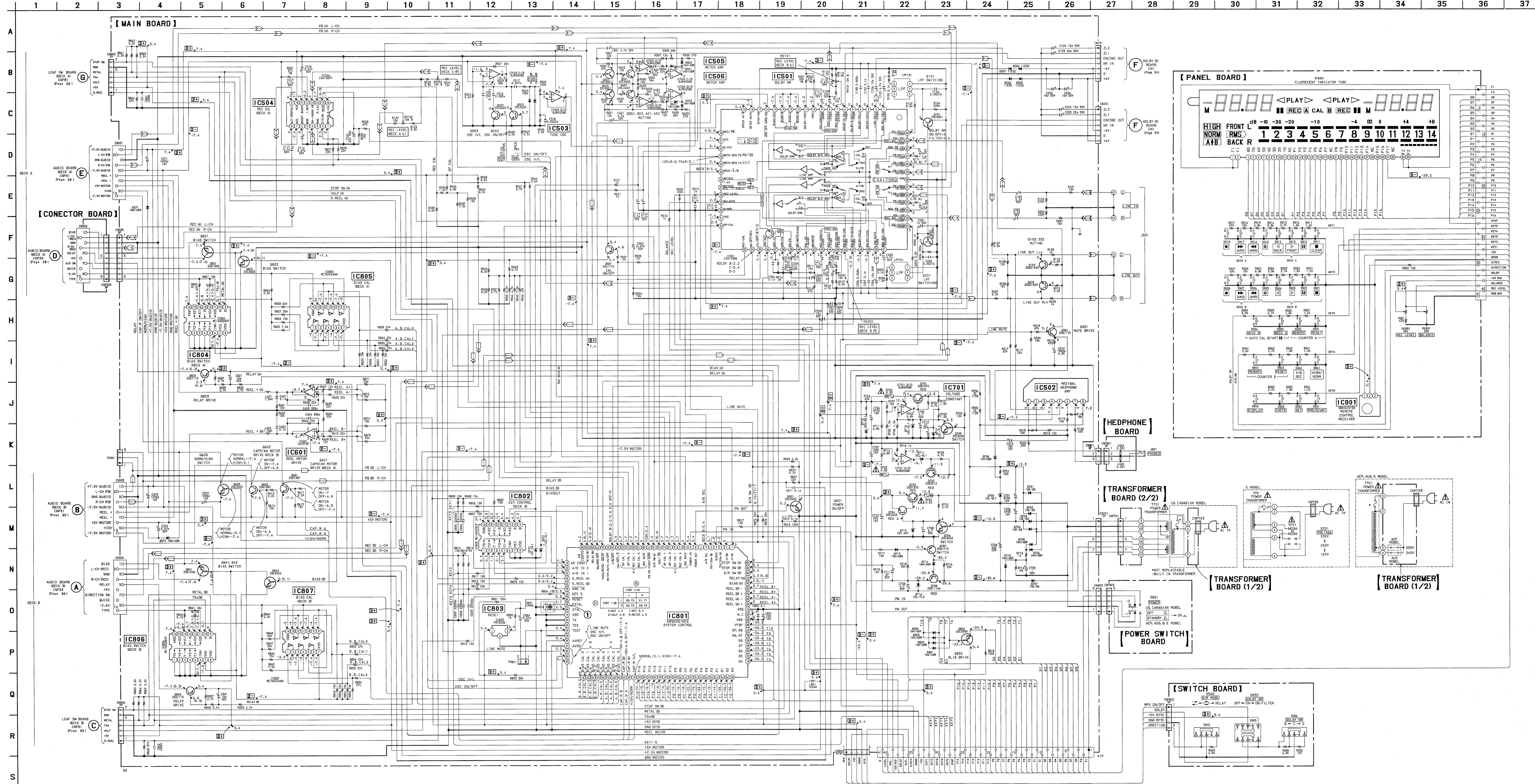

**Note :**

- All capacitors are in  $\mu$ F unless otherwise noted. pF:  $\mu$ F
- 50WV or less are not indicated except for electrolytics and tantalums.
- All resistors are in  $\Omega$  and  $\frac{1}{2}W$  or less unless otherwise specified.
- $\Delta$  : internal component.
- $\sim$  : fusible resistor.

**Note :**  
The components identified by mark  $\Delta$  or dot line with mark  $\Delta$  are critical for safety. Replace only with part number specified.

**Note :**  
Les composants identifiés par une marque  $\Delta$  sont critiques pour la sécurité. Ne les remplacer que par une pièce portant le numéro spécifié.

- B+** : B+ Line
- B-** : B- Line
- $\square$  : adjustment for repair.

Voltage and waveforms are dc with respect to ground under no-signal conditions.  
no mark : STOP  
( ) : REC

Voltages are taken with a VOM (Input impedance  $10M\Omega$ ).  
Voltage variations may be noted due to normal production tolerances.

Waveforms are taken with an oscilloscope.  
Voltage variations may be noted due to normal production tolerances.

Circled numbers refer to waveforms.

Signal path.

- $\Rightarrow$  : PB (DECK A)
- $\Rightarrow$  : REC (DECK A)
- $\Rightarrow$  : PB (DECK B)
- $\Rightarrow$  : REC (DECK B)

Abbreviation  
G : German  
AUS : Australian

5-5. SCHEMATIC DIAGRAM (AUDIO SECTION)

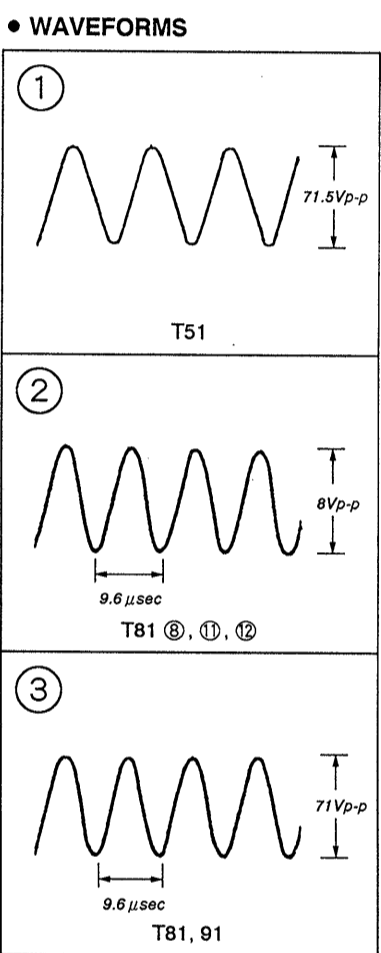
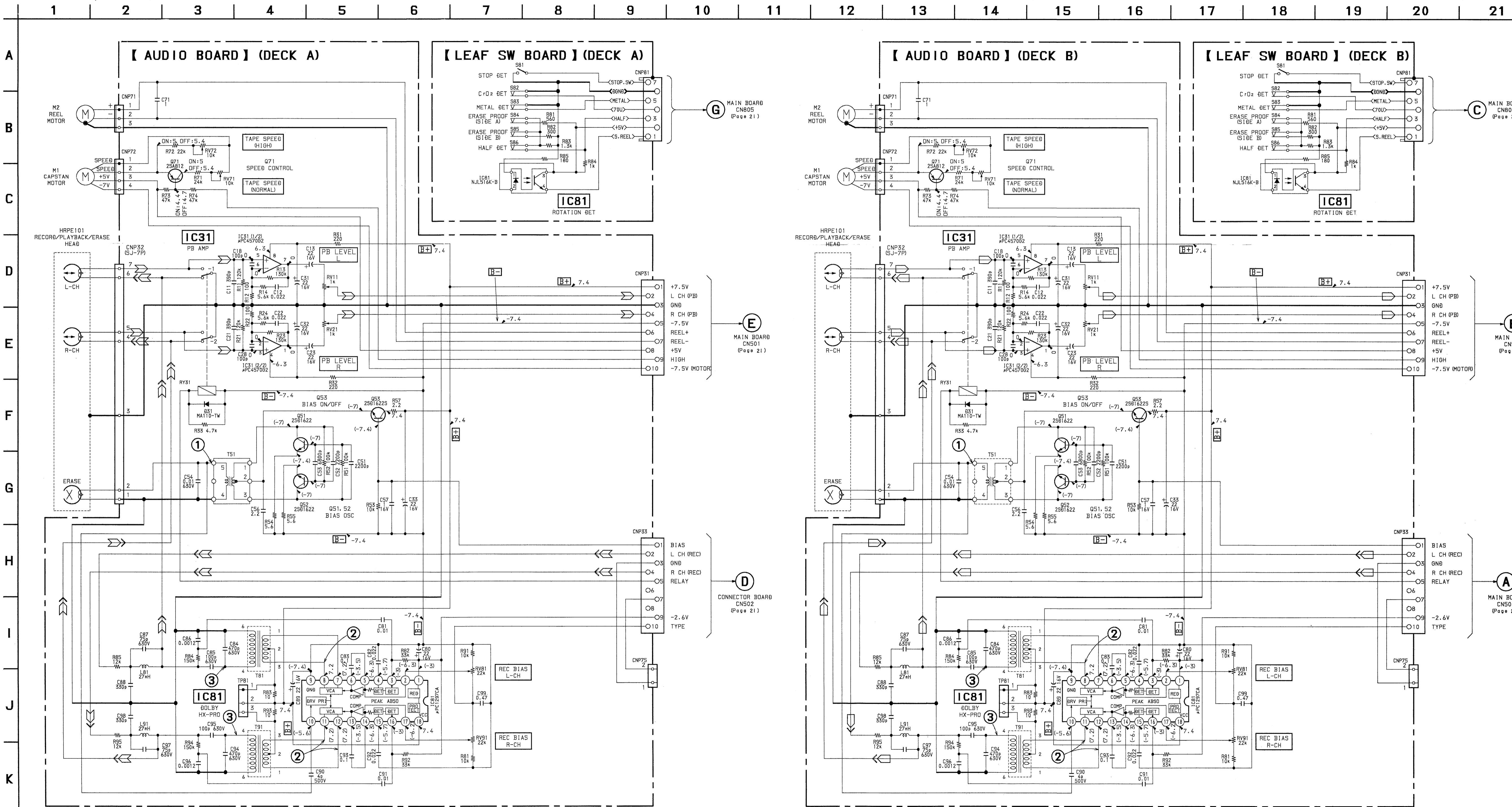

**Note :**

- All capacitors are in  $\mu$ F unless otherwise noted.  $\mu$ Pf:  $\mu$ F 50WV or less are not indicated except for electrolytics and tantalums.
- All resistors are in  $\Omega$  and  $\frac{1}{4}W$  or less unless otherwise specified.
- B+** : B+ Line
- B-** : B- Line
- : adjustment for repair.
- Voltage and waveforms are dc with respect to ground under no-signal conditions. no mark : STOP
- ( ) : REC
- Voltages are taken with a VOM (input impedance 10M  $\Omega$ ). Voltage variations may be noted due to normal production tolerances.
- Waveforms are taken with an oscilloscope. Voltage variations may be noted due to normal production tolerances.
- Circled numbers refer to waveforms.
- Signal path.
- $\Rightarrow$  PB (DECK A)
- $\Rightarrow$  REC (DECK A)
- $\Rightarrow$  PB (DECK B)
- $\Rightarrow$  REC (DECK B)



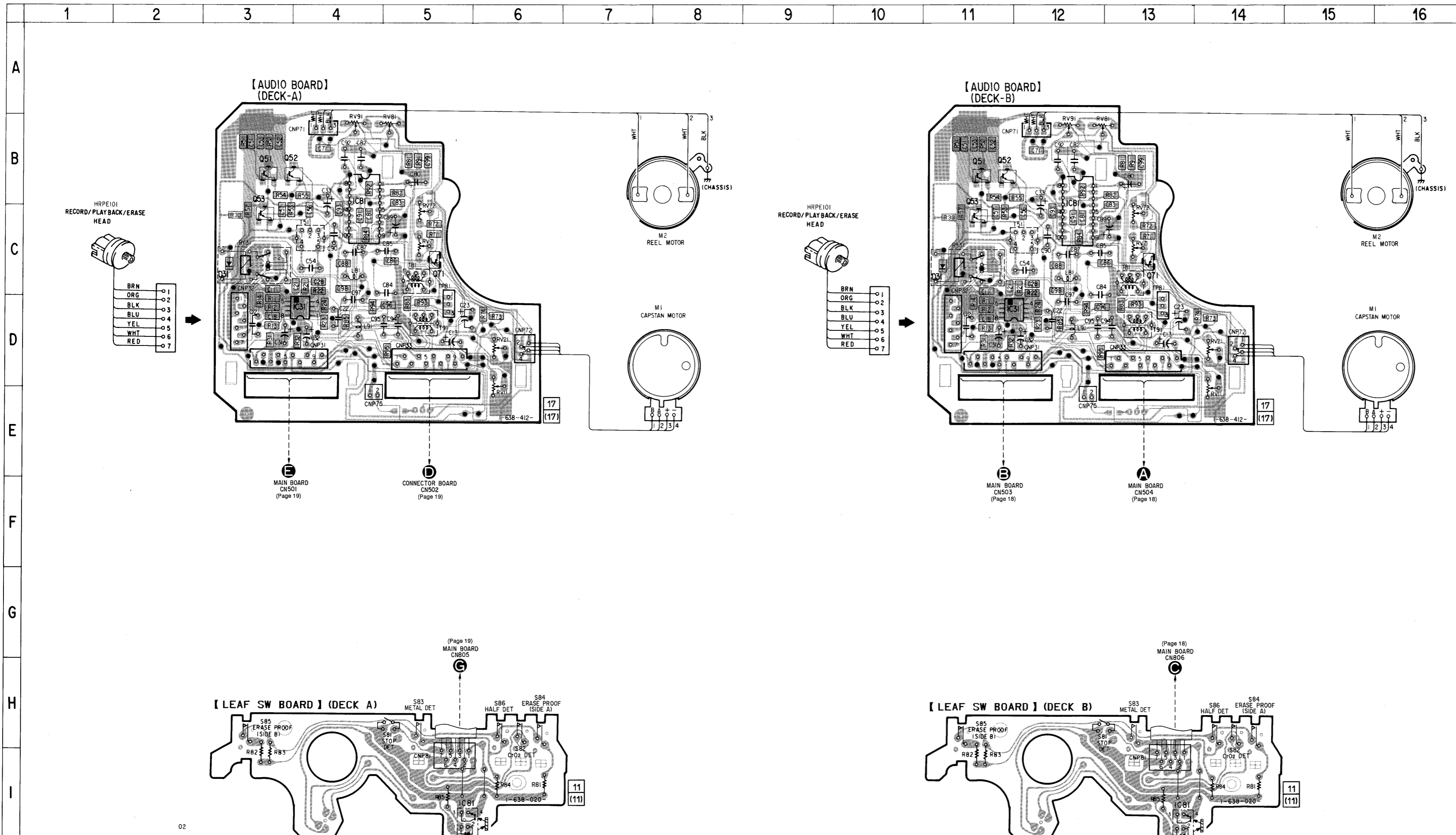

● SEMICONDUCTOR LOCATION (DECK-A)

Ref. No.	Location
D31	C-3
IC31	D-4
IC81	B-4
(AUDIO)	
IC81	I-5
(LEAF SW)	
Q51	B-3
Q52	B-3
Q53	C-3
Q71	C-5

(DECK-B)

Ref. No.	Location
D31	C-11
IC31	D-11
IC81	B-12
(AUDIO)	
IC81	I-13
(LEAF SW)	
Q51	B-11
Q52	B-11
Q53	C-11
Q71	C-13

Note:

- : parts extracted from the component side.
- : parts mounted on the conductor side.
- : Through hole.
- ▨ : Pattern on the side which is seen.
- ▩ : Pattern of the rear side.

5-7. PRINTED WIRING BOARDS (DOLBY (S) SECTION)

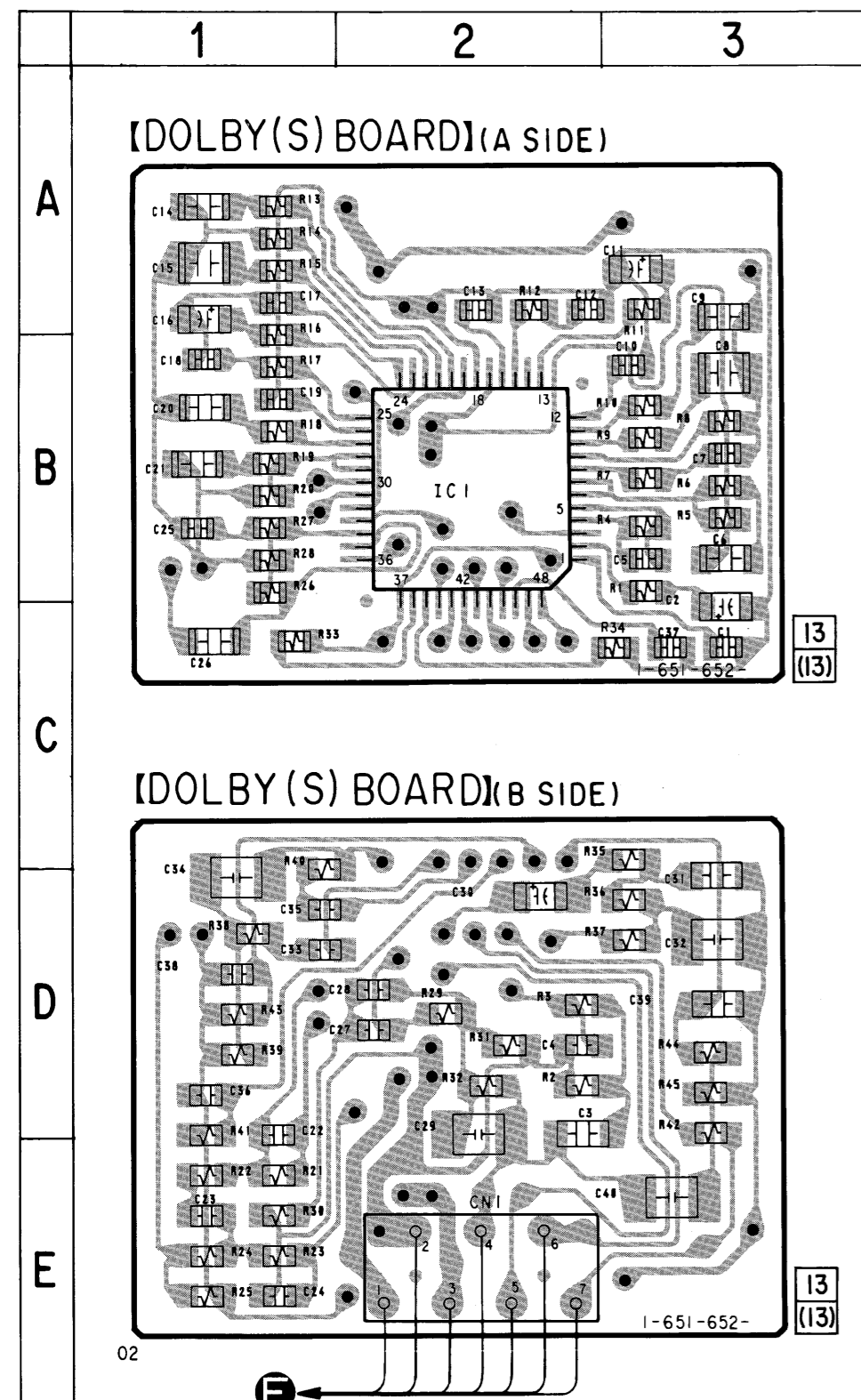

MAIN BOARD  
L-CH: CN131  
R-CH: CN231  
(Page 17)

5-8. SCHEMATIC DIAGRAM (DOLBY (S) SECTION)

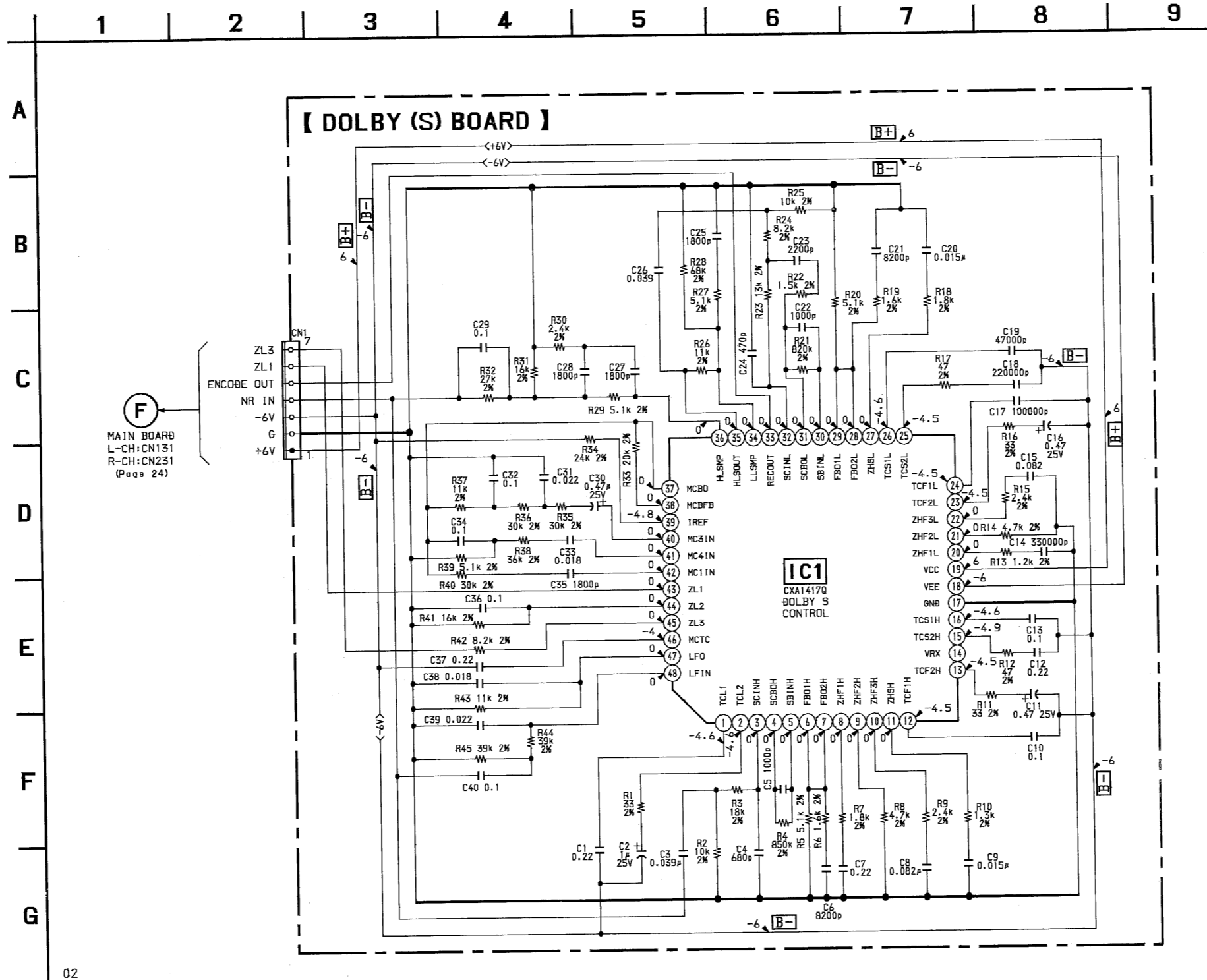

Note:  
 ○ : parts extracted from the component side.  
 ● : Through hole.  
 [Pattern] : Pattern from the side which enables seeing. (The other layers' patterns are not indicated)

Caution:  
 Pattern face side : Parts on the pattern face side seen from (Conductor Side) the pattern face are indicated.  
 Parts face side : Parts on the parts face side seen from the (Component side) parts face are indicated.

Note:  
 • All capacitors are in  $\mu F$  unless otherwise noted.  $pF$ :  $\mu F$   
 50WV or less are not indicated except for electrolytics and tantalums.  
 • All resistors are in  $\Omega$  and  $\frac{1}{4}W$  or less unless otherwise specified.  
 • % : indicates tolerance.  
 • [B+] : B+ Line  
 • [B-] : B- Line  
 • [ ] : adjustment for repair.

• Voltage and waveforms are dc with respect to ground under no-signal conditions.  
 no mark : STOP  
 • Voltages are taken with a VOM ( Input impedance  $10M \Omega$  ).  
 Voltage variations may be noted due to normal production tolerances.

• IC BLOCK DIAGRAMS  
IC1 CX1417Q

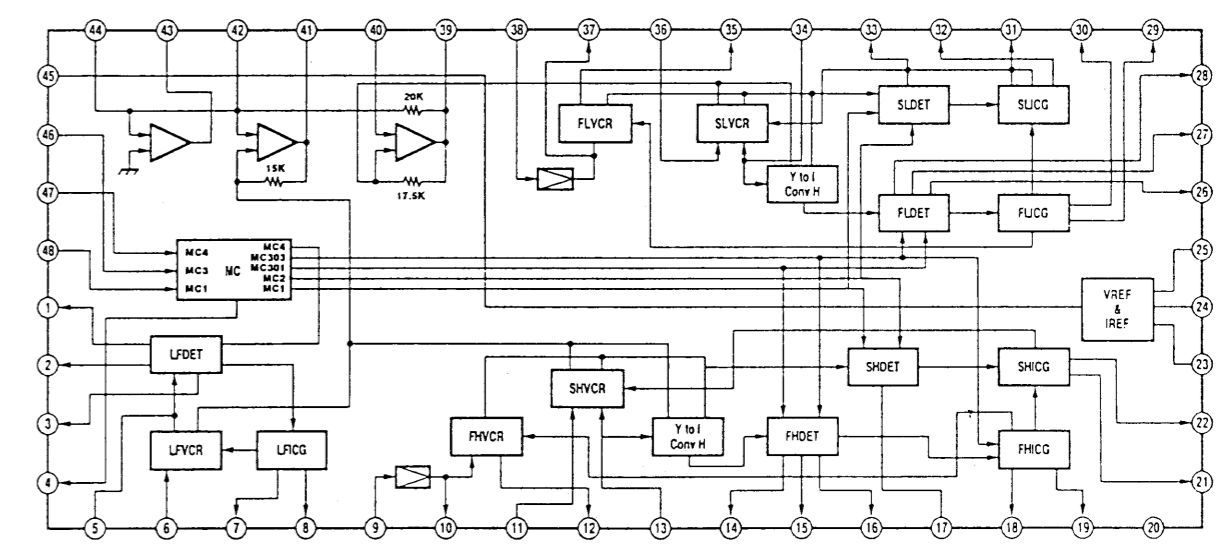

## SECTION 6 EXPLODED VIEWS

**NOTE :**

- -XX, -X mean standardized parts, so they may have some difference from the original one.
- The construction parts of an assembled part are indicated with a collation number in the remark column.
- Items marked " \* " are not stocked since they are seldom required for routine service. Some delay should be anticipated when ordering these items.

- The mechanical parts with no reference number in the exploded views are not supplied.
- Hardware ( # mark) list and accessories and packing materials are given in the last of this parts list.
- Abbreviation  
CND : Canadian  
G : German  
AUS : Australian

The components identified by mark  $\triangle$  or dotted line with mark  $\triangle$  are critical for safety. Replace only with part number specified.

Les composants identifiés par une marque  $\triangle$  sont critiques pour la sécurité. Ne les remplacer que par une pièce portant le numéro spécifié.

### 6-1. CHASSIS SECTION

- $\triangle$  A : CONNECTOR BOARD
- $\triangle$  B : TRANSFORMER BOARD (2/2)
- $\triangle$  C : TRANSFORMER BOARD (1/2)

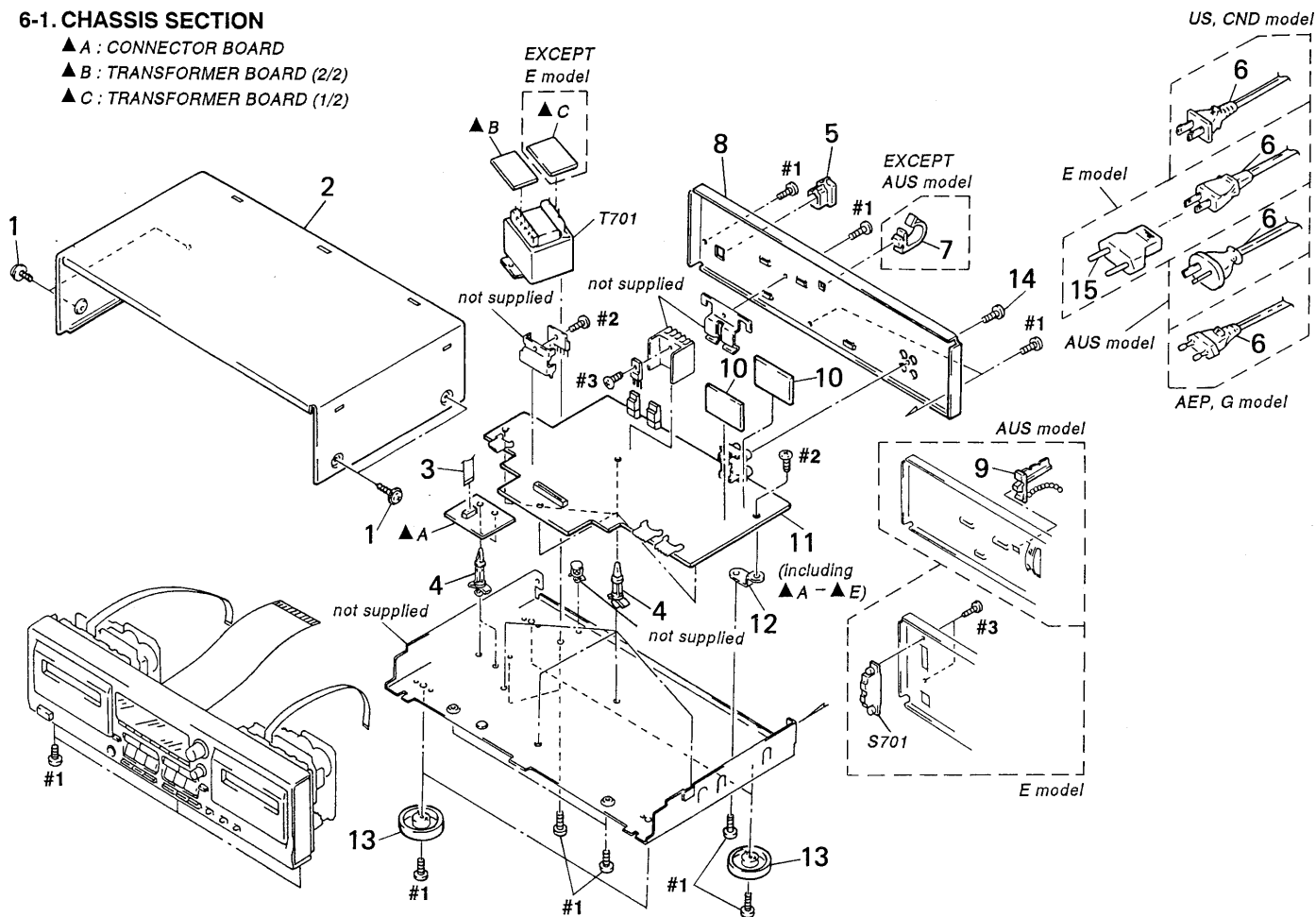

Ref. No.	Part No.	Description	Remark	Ref. No.	Part No.	Description	Remark
1	3-704-366-01	SCREW (CASE) (M3×8)		9	4-956-370-02	BAND, PLUG FIXED (AUS)	
2	3-332-578-61	CASE		* 10	A-2007-173-A	DOLBY (S) BOARD, COMPLETE	
3	1-575-849-11	WIRE, FLAT TYPE (9 CORE)		* 11	A-2007-399-A	MAIN BOARD, COMPLETE (US, CND)	
* 4	3-346-265-11	HOLDER, PC BOARD		* 11	A-2007-402-A	MAIN BOARD, COMPLETE (AEP, G)	
* 5	3-703-244-00	BUSHING (2104), CORD (AEP, G, AUS)		* 11	A-2007-403-A	MAIN BOARD, COMPLETE (E)	
* 5	3-703-571-11	BUSHING (S) (4516), CORD (US, CND, E)		* 11	A-2007-404-A	MAIN BOARD, COMPLETE (AUS)	
$\triangle$ 6	1-551-188-XX	CORD, POWER (E)		* 12	3-332-563-01	BRACKET (P)	
$\triangle$ 6	1-558-945-21	CORD, POWER (POLAR. SPT-1) (US, CND)		13	4-956-885-01	FOOT (F58175S2W) (WA8ES)	
$\triangle$ 6	1-575-651-21	CORD, POWER (AEP, G)		13	4-956-885-11	FOOT (F58175S2W) (WR765S)	
$\triangle$ 6	1-696-845-11	CORD, POWER (AUS)		14	3-704-515-01	SCREW (BV/RING)	
* 7	4-949-235-01	HOOK (EXCEPT AUS)		15	1-569-007-11	ADAPTER, CONVERSION 2P (E)	
* 8	3-923-288-01	PANEL, BACK (US, CND)		$\triangle$ S701	1-692-155-11	SELECTOR, POWER VOLTAGE (VOLTAGE SELECTOR) (E)	
* 8	3-923-288-11	PANEL, BACK (AEP, G)		$\triangle$ T701	1-426-784-11	TRANSFORMER, POWER (US, CND)	
* 8	3-923-288-21	PANEL, BACK (E)		$\triangle$ T701	1-426-785-11	TRANSFORMER, POWER (AEP, G, AUS)	
* 8	3-923-288-31	PANEL, BACK (AUS)		$\triangle$ T701	1-426-910-11	TRANSFORMER, POWER (E)	

## 6-2. FRONT PANEL SECTION

- ▲ D : POWER SWITCH BOARD
- ▲ E : SWITCH BOARD
- F : HEADPHONE BOARD

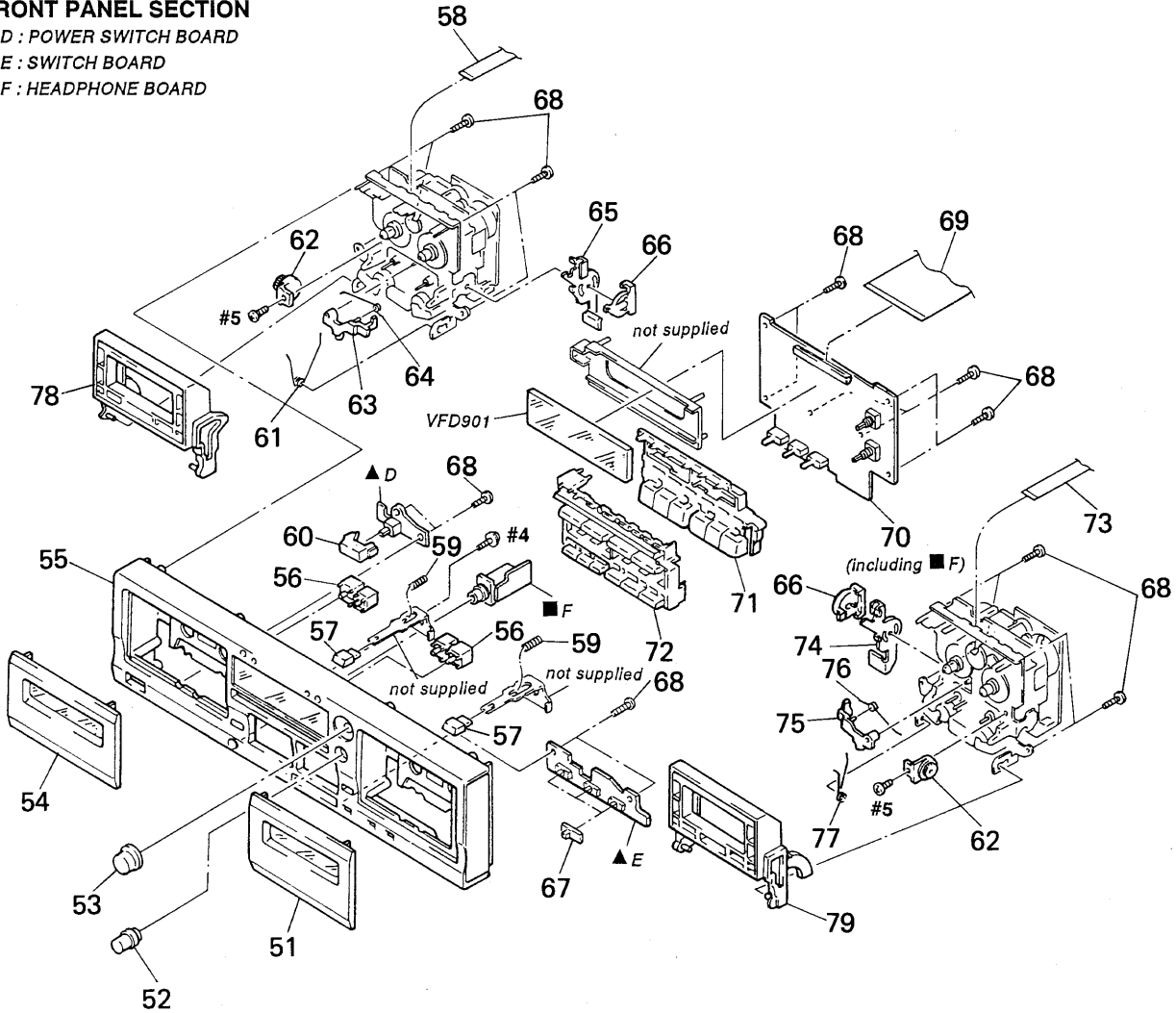

Ref.No.	Part No.	Description	Remark	Ref.No.	Part No.	Description	Remark
51	X-3369-657-1	LID (B) ASSY, CASSETTE (WA8ES)		64	3-354-962-01	SPRING (EJ SAFTY SPRING R)	
51	X-3370-148-1	LID (B) ASSY, CASSETTE (WR765S)		* 65	3-354-954-01	LEVER (LOCK LEVER R)	
52	3-367-431-01	KNOB (BAL)		66	3-354-957-01	JOINT (LOCK LEVER)	
53	3-909-661-11	KNOB (REC)		67	3-350-138-11	KNOB (SLIDE)	
54	X-3369-656-1	LID (A) ASSY, CASSETTE (WA8ES)		68	4-951-620-01	SCREW (2.6×8), +BVTP	
54	X-3370-147-1	LID (A) ASSY, CASSETTE (WR765S)		69	1-769-598-11	WIRE (FLAT TYPE) (41 CORE)	
55	X-3370-144-1	PANEL ASSY, FRONT (WA8ES:US)		* 70	A-2007-400-A	PANEL BOARD, COMPLETE	
55	X-3370-145-1	PANEL ASSY, FRONT (WA8ES:Canadian)		71	3-910-810-01	BUTTON (FR-J)	
55	X-3370-146-1	PANEL ASSY, FRONT (WR765S)		72	3-910-812-01	BUTTON (WR)	
56	3-377-329-11	BUTTON (COUNTER)		73	1-775-308-11	WIRE (FLAT TYPE) (7 CORE)	
57	3-377-328-01	BUTTON (EJECT)		* 74	3-354-953-01	LEVER (LOCK LEVER L)	
58	1-775-307-21	WIRE (FLAT TYPE) (7 CORE)		75	3-354-955-01	LEVER (EJ SAFTY LEVER L)	
59	3-382-382-01	SPRING, COMPRESSION		76	3-354-961-01	SPRING (EJ SAFTY SPRING L)	
60	3-354-932-01	BUTTON (POWER)		77	3-354-959-01	SPRING (LOADING L), TORSION	
61	3-354-960-01	SPRING (LOADING R), TORSION		78	X-3370-143-1	HOLDER (R) ASSY, CASSETTE	
62	3-354-963-01	DAMPER		79	X-3370-142-1	HOLDER (L) ASSY, CASSETTE	
63	3-354-956-01	LEVER (EJ SAFTY LEVER R)		VFD901	1-517-263-11	INDICATOR TUBE, FLUORESCENT	

**6-3. MECHANISM SECTION 1**  
**(TCM-190RB12CL : DECK A, DECK B)**

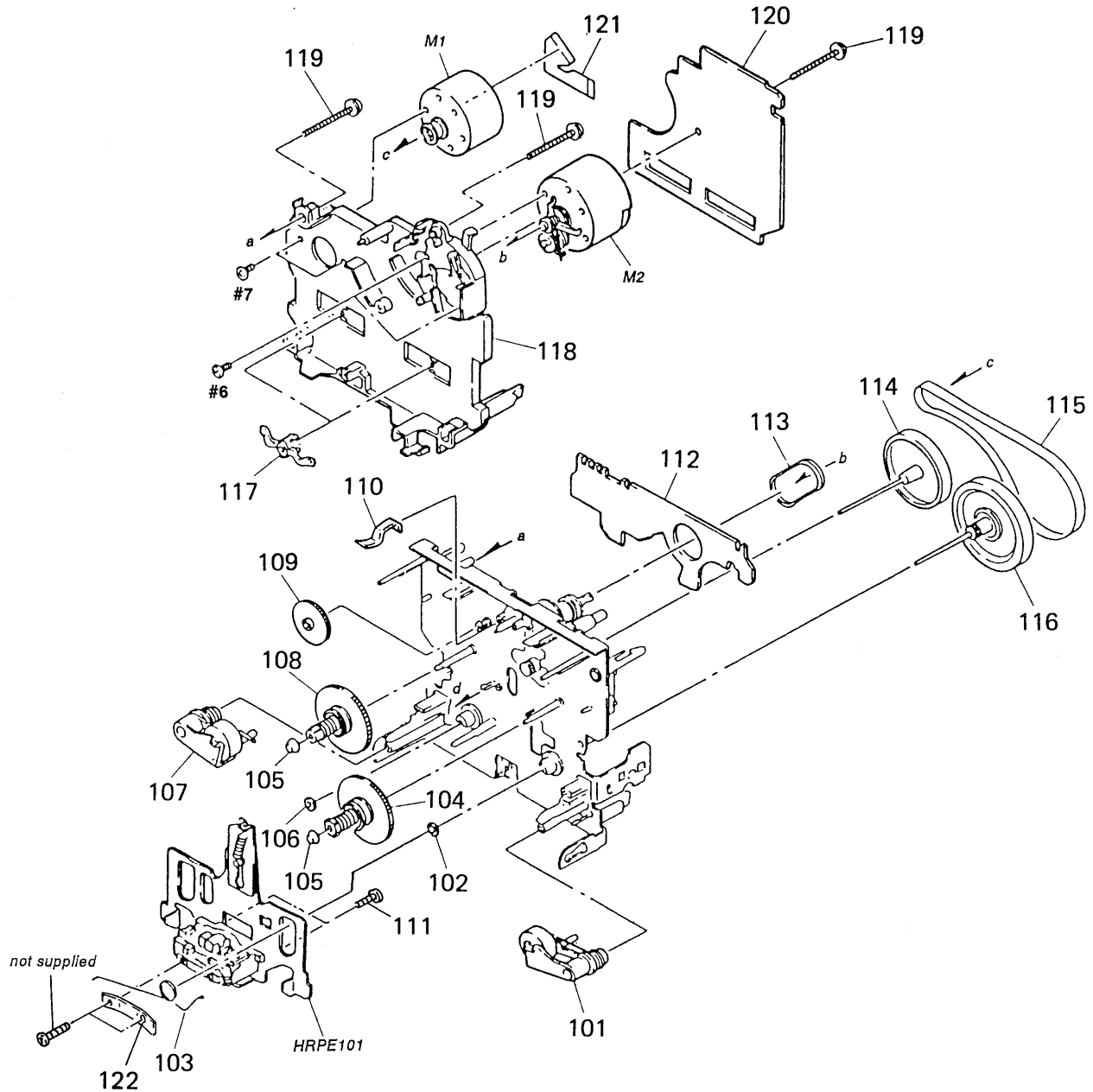

Ref.No.	Part No.	Description	Remark	Ref.No.	Part No.	Description	Remark
101	X-3366-047-1	LEVER (PINCH F) ASSY		114	X-3367-630-1	FLYWHEEL (REV) ASSY	
102	3-356-713-01	WASHER		115	3-359-417-01	BELT (FLAT), CAPSTAN	
103	3-907-362-01	SPRING, TORSION		116	X-3367-629-1	FLYWHEEL (FWD) ASSY	
104	X-3366-970-1	TABLE ASSY, REEL		117	3-575-321-00	RETAINER, THRUST, CAPSTAN	
105	3-362-308-01	CAP (REEL)		118	3-359-436-11	BASE (THRUST RETAINER), FITTING	
106	3-356-714-01	WASHER		119	3-359-414-01	SCREW (+PTPWH 2×23)	
107	X-3366-048-1	LEVER (PINCH R) ASSY		* 120	A-2007-040-A	AUDIO BOARD, COMPLETE	
108	X-3366-971-1	TABLE ASSY (B), REEL		121	1-638-983-11	PC BOARD, MOTOR FLEXIBLE	
109	3-359-424-01	GEAR (REV GEAR)		122	3-386-433-11	SPRING, LEAF	
110	3-359-430-01	SPRING (CASSETTE RETAINER), LEAF		HRPE101A-2003-930-A	BASE ASSY, HEAD (RECORD/PLAYBACK/ERASE)		
111	3-388-848-01	SCREW (P2×6) (B TIGHT)		M1	X-3365-377-2	MOTOR ASSY (CAPSTAN)	
* 112	1-638-020-11	PC BOARD, LEAF SW BOARD		M2	X-3363-501-2	MOTOR ASSY (REEL)	
113	3-359-466-01	BELT (FR), SQUARE					

6-4. MECHANISM SECTION 2  
(TCM-190RB12CL : DECK A, DECK B)

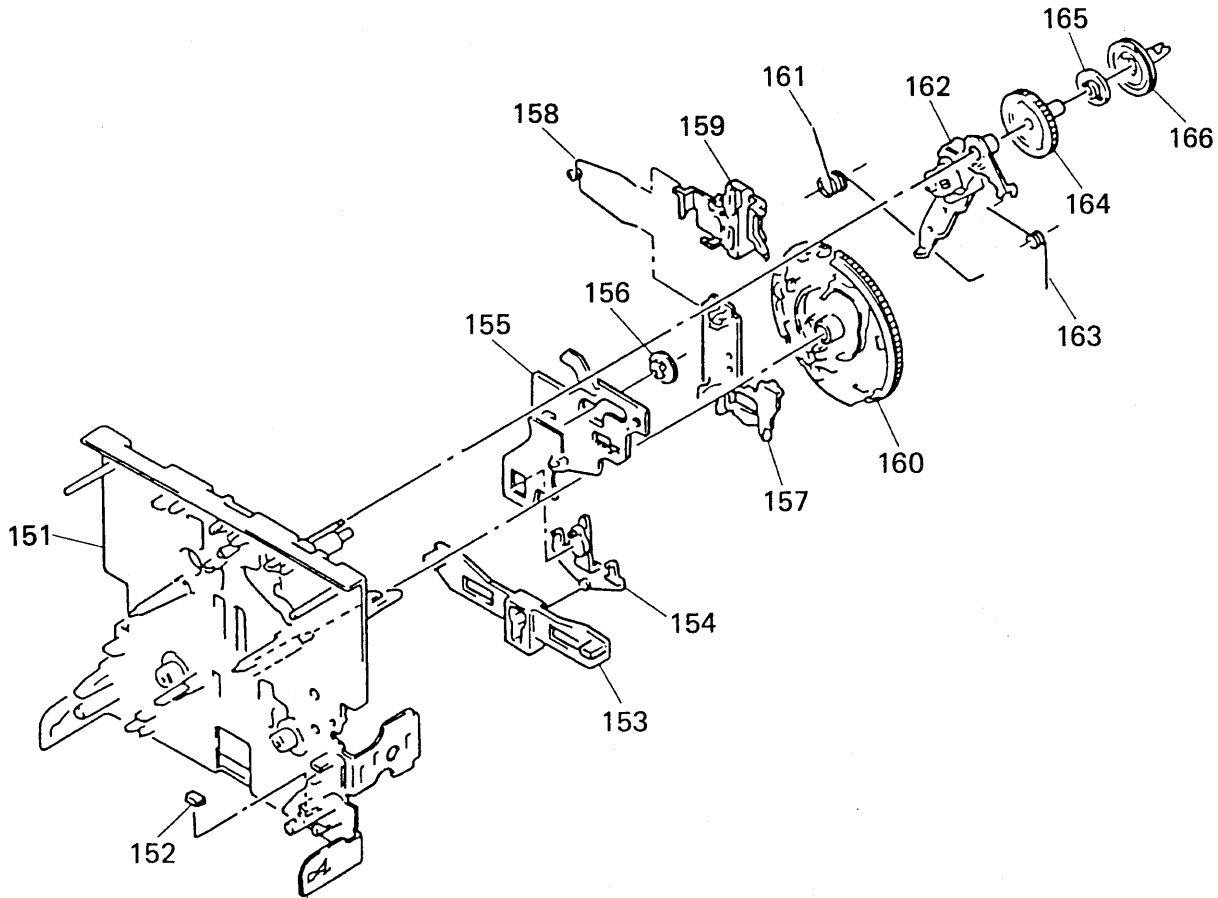

Ref.No.	Part No.	Description	Remark	Ref.No.	Part No.	Description	Remark
151	X-3359-415-1	CHASSIS ASSY MECHANICAL		159	3-359-429-01	SLIDER (BRAKE PLATE)	
152	3-359-469-01	SPACER		160	3-359-420-01	GEAR (CAM GEAR)	
153	3-359-425-01	SLIDER (REVERSE SLIDER)		161	3-359-456-01	SPRING (TRIGGER SPRING), TORSION	
154	3-359-426-01	LEVER (REVERSE LEVER)		162	X-3366-569-1	ARM ASSY, FR	
* 155	3-359-415-01	SLIDER (TRIGGER SLIDER)		163	3-924-185-11	SPRING (FR ARM), TORSION	
156	3-359-448-01	GEAR (TRIGGER)		164	3-359-419-11	GEAR (FR GEAR)	
157	3-359-427-01	SLIDER (LEVERSE SLIDER)		165	3-359-421-01	CLUTCH (REEL DISK)	
158	3-359-454-01	SPRING, TORSION		166	3-359-418-01	PULLEY (FR PULLEY)	

## SECTION 7 ELECTRICAL PARTS LIST

AUDIO

**NOTE :**

- Due to standardization, replacements in the parts list may be different from the parts specified in the diagrams or the components used on the set.
- -XX, -X mean standardized parts, so they may have some difference from the original one.
- RESISTORS  
All resistors are in ohms  
METAL : Metal-film resistor  
METAL OXIDE : Metal oxide-film resistor  
F : nonflammable

- Items marked “ \* ” are not stocked since they are seldom required for routine service. Some delay should be anticipated when ordering these items.
- SEMICONDUCTORS  
In each case, u :  $\mu$ , for example :  
uA.... :  $\mu$  A.... , uPA.... :  $\mu$  PA....  
uPB.... :  $\mu$  PB.... , uPC.... :  $\mu$  PC....  
uPD.... :  $\mu$  PD....
- CAPACITORS  
uF :  $\mu$  F
- COILS  
uH :  $\mu$  H

- Abbreviation  
CND : Canadian  
G : German  
AUS : Australian

The components identified by mark  $\Delta$  or dotted line with mark  $\Delta$  are critical for safety. Replace only with part number specified.

Les composants identifiés par une marque  $\Delta$  sont critiques pour la sécurité. Ne les remplacer que par une pièce portant le numéro spécifié.

When indicating parts by reference number, please include the board.

Ref.No.	Part No.	Description	Remark	Ref.No.	Part No.	Description	Remark
*	A-2007-040-A	AUDIO BOARD, COMPLETE *****		C97	1-136-273-91	FILM 75PF	5% 630V
		< CAPACITOR >		C98	1-163-003-11	CERAMIC CHIP 330PF	10% 50V
C11	1-163-131-00	CERAMIC CHIP 390PF	5% 50V	C99	1-164-005-11	CERAMIC CHIP 0.47uF	25V
C12	1-136-157-00	FILM 0.022uF	5% 50V			< CONNECTOR >	
C13	1-124-234-00	ELECT 22uF	20% 16V	* CNP31	1-580-782-11	CONNECTOR, BOARD TO BOARD	
C18	1-163-117-00	CERAMIC CHIP 100PF	5% 50V	* CNP32	1-580-781-11	PIN, CONNECTOR (PC BOARD) 7P	
C21	1-163-131-00	CERAMIC CHIP 390PF	5% 50V	* CNP33	1-580-782-11	CONNECTOR, BOARD TO BOARD	
C22	1-136-157-00	FILM 0.022uF	5% 50V	* CNP71	1-564-719-11	PIN, CONNECTOR (SMALL TYPE) 3P	
C23	1-124-234-00	ELECT 22uF	20% 16V	CNP72	1-764-902-11	CONNECTOR, FFC/FPC 4P	
C28	1-163-117-00	CERAMIC CHIP 100PF	5% 50V	* CNP75	1-564-718-11	PIN, CONNECTOR (SMALL TYPE) 2P	
C31	1-124-234-00	ELECT 22uF	20% 16V			< DIODE >	
C32	1-124-234-00	ELECT 22uF	20% 16V	D31	8-719-404-46	DIODE MA110	
C33	1-124-234-00	ELECT 22uF	20% 16V			< IC >	
C51	1-164-161-11	CERAMIC CHIP 0.0022uF	10% 100V	IC31	8-759-106-02	IC uPC4570G2	
C52	1-164-161-11	CERAMIC CHIP 0.0022uF	10% 100V	IC81	8-759-106-56	IC uPC1297CA	
C53	1-163-019-00	CERAMIC CHIP 0.0068uF	10% 50V			< COIL >	
C54	1-136-601-11	FILM 0.01uF	5% 630V	L81	1-410-780-11	INDUCTOR 27mH	
C56	1-164-505-11	CERAMIC CHIP 2.2uF	16V	L91	1-410-780-11	INDUCTOR 27mH	
C57	1-164-346-11	CERAMIC CHIP 1uF	16V			< TRANSISTOR >	
C71	1-164-346-11	CERAMIC CHIP 1uF	16V	Q51	8-729-808-01	TRANSISTOR 2SD1622-S	
C80	1-124-234-00	ELECT 22uF	20% 16V	Q52	8-729-808-01	TRANSISTOR 2SD1622-S	
C81	1-164-232-11	CERAMIC CHIP 0.01uF	50V	Q53	8-729-808-01	TRANSISTOR 2SD1622-S	
C82	1-136-157-00	FILM 0.022uF	5% 50V	Q71	8-729-216-22	TRANSISTOR 2SA1162-G	
C83	1-164-004-11	CERAMIC CHIP 0.1uF	10% 25V			< RESISTOR >	
C84	1-136-478-11	FILM 470PF	5% 630V	R11	1-216-099-00	METAL CHIP 120K 5% 1/10W	
C85	1-136-433-11	FILM 100PF	5% 630V	R12	1-216-025-00	METAL GLAZE 100 5% 1/10W	
C86	1-163-143-00	CERAMIC CHIP 0.0012uF	5% 50V	R13	1-216-100-00	METAL GLAZE 130K 5% 1/10W	
C87	1-136-273-91	FILM 75PF	5% 630V	R14	1-216-067-00	METAL CHIP 5.6K 5% 1/10W	
C88	1-163-003-11	CERAMIC CHIP 330PF	10% 50V	R21	1-216-099-00	METAL CHIP 120K 5% 1/10W	
C89	1-124-234-00	ELECT 22uF	20% 16V	R22	1-216-025-00	METAL GLAZE 100 5% 1/10W	
C90	1-107-584-11	CERAMIC 4PF	0.25PF 500V	R23	1-216-100-00	METAL GLAZE 130K 5% 1/10W	
C91	1-164-232-11	CERAMIC CHIP 0.01uF	50V	R24	1-216-067-00	METAL CHIP 5.6K 5% 1/10W	
C92	1-136-157-00	FILM 0.022uF	5% 50V				
C93	1-164-004-11	CERAMIC CHIP 0.1uF	10% 25V				
C94	1-136-478-11	FILM 470PF	5% 630V				
C95	1-136-433-11	FILM 100PF	5% 630V				
C96	1-163-143-00	CERAMIC CHIP 0.0012uF	5% 50V				

# AUDIO

# DOLBY (S)

Ref.No.	Part No.	Description	Remark
R31	1-216-033-00	METAL CHIP	220 5% 1/10W
R32	1-216-033-00	METAL CHIP	220 5% 1/10W
R33	1-216-065-00	METAL CHIP	4.7K 5% 1/10W
R51	1-216-097-00	METAL CHIP	100K 5% 1/10W
R52	1-216-097-00	METAL CHIP	100K 5% 1/10W
R53	1-216-073-00	METAL CHIP	10K 5% 1/10W
R54	1-216-309-00	METAL CHIP	5.6 5% 1/10W
R55	1-216-309-00	METAL CHIP	5.6 5% 1/10W
R57	1-216-298-00	METAL CHIP	2.2 5% 1/10W
R71	1-216-082-00	METAL GLAZE	24K 5% 1/10W
R72	1-216-081-00	METAL CHIP	22K 5% 1/10W
R73	1-216-089-00	METAL CHIP	47K 5% 1/10W
R74	1-216-089-00	METAL CHIP	47K 5% 1/10W
R81	1-216-073-00	METAL CHIP	10K 5% 1/10W
R82	1-216-085-00	METAL CHIP	33K 5% 1/10W
R83	1-216-001-00	METAL CHIP	10 5% 1/10W
R84	1-216-101-00	METAL CHIP	150K 5% 1/10W
R85	1-216-075-00	METAL CHIP	12K 5% 1/10W
R91	1-216-073-00	METAL CHIP	10K 5% 1/10W
R92	1-216-085-00	METAL CHIP	33K 5% 1/10W
R93	1-216-001-00	METAL CHIP	10 5% 1/10W
R94	1-216-101-00	METAL CHIP	150K 5% 1/10W
R95	1-216-075-00	METAL CHIP	12K 5% 1/10W
< VARIABLE RESISTOR >			
RV11	1-241-761-11	RES, ADJ, CARBON 1K (PB LEVEL, L)	
RV21	1-241-761-11	RES, ADJ, CARBON 1K (PB LEVEL, R)	
RV71	1-241-630-11	RES, ADJ, CARBON 10K (TAPE SPEED, NORMAL)	
RV72	1-241-630-11	RES, ADJ, CARBON 10K (TAPE SPEED, HIGH)	
RV81	1-241-786-11	RES, ADJ, CARBON 22K (REC BIAS, L)	
RV91	1-241-786-11	RES, ADJ, CARBON 22K (REC BIAS, R)	
< RELAY >			
RY31	1-515-913-11	RELAY	
< TRANSFORMER >			
T51	1-406-417-11	COIL, BIAS OSCILLATION	
T81	1-433-381-11	TRANSFORMER, BIAS OSCILLATOR	
T91	1-433-381-11	TRANSFORMER, BIAS OSCILLATOR	
< TEST PIN >			
* TP81	1-568-449-11	HOUSING, CONNECTOR (PC BOARD) 3P	
*****			

Ref.No.	Part No.	Description	Remark
*	A-2007-173-A	DOLBY (S) BOARD, COMPLETE *****	
< CAPACITOR >			
C1	1-164-222-11	CERAMIC CHIP	0.22uF 25V
C2	1-135-177-21	TANTALUM CHIP	1uF 20V
C3	1-104-558-11	FILM CHIP	0.039uF 5% 16V
C4	1-163-007-11	CERAMIC CHIP	680PF 10% 50V
C5	1-163-009-11	CERAMIC CHIP	0.001uF 10% 50V
C6	1-164-717-11	CERAMIC CHIP	0.0082uF 5% 50V
C7	1-164-222-11	CERAMIC CHIP	0.22uF 25V
C8	1-104-562-11	FILM CHIP	0.082uF 5% 16V
C9	1-104-553-11	FILM CHIP	0.015uF 5% 16V
C10	1-165-319-11	CERAMIC CHIP	0.1uF 50V
C11	1-135-145-11	TANTALUM CHIP	0.47uF 10% 35V
C12	1-164-222-11	CERAMIC CHIP	0.22uF 25V
C13	1-165-319-11	CERAMIC CHIP	0.1uF 50V
C14	1-162-568-11	CERAMIC CHIP	0.33uF 10% 16V
C15	1-104-562-11	FILM CHIP	0.082uF 5% 16V
C16	1-135-145-11	TANTALUM CHIP	0.47uF 10% 35V
C17	1-165-319-11	CERAMIC CHIP	0.1uF 50V
C18	1-164-222-11	CERAMIC CHIP	0.22uF 25V
C19	1-163-035-00	CERAMIC CHIP	0.047uF 50V
C20	1-104-553-11	FILM CHIP	0.015uF 5% 16V
C21	1-164-717-11	CERAMIC CHIP	0.0082uF 5% 50V
C22	1-163-009-11	CERAMIC CHIP	0.001uF 10% 50V
C23	1-164-161-11	CERAMIC CHIP	0.0022uF 10% 100V
C24	1-163-005-11	CERAMIC CHIP	470PF 10% 50V
C25	1-163-012-00	CERAMIC CHIP	0.0018uF 10% 50V
C26	1-104-558-11	FILM CHIP	0.039uF 5% 16V
C27	1-163-012-00	CERAMIC CHIP	0.0018uF 10% 50V
C28	1-163-012-00	CERAMIC CHIP	0.0018uF 10% 50V
C29	1-104-563-11	FILM CHIP	0.1uF 5% 16V
C30	1-135-145-11	TANTALUM CHIP	0.47uF 10% 35V
C31	1-104-555-11	FILM CHIP	0.022uF 5% 16V
C32	1-104-563-11	FILM CHIP	0.1uF 5% 16V
C33	1-163-024-00	CERAMIC CHIP	0.018uF 10% 50V
C34	1-104-563-11	FILM CHIP	0.1uF 5% 16V
C35	1-163-012-00	CERAMIC CHIP	0.0018uF 10% 50V
C36	1-165-319-11	CERAMIC CHIP	0.1uF 50V
C37	1-164-222-11	CERAMIC CHIP	0.22uF 25V
C38	1-163-024-00	CERAMIC CHIP	0.018uF 10% 50V
C39	1-104-555-11	FILM CHIP	0.022uF 5% 16V
C40	1-104-563-11	FILM CHIP	0.1uF 5% 16V
< CONNECTOR >			
CN1	1-695-092-11	SOCKET, CONNECTOR 7P	



**DOLBY (S)**

**LEAF SW**

**MAIN**

**SWITCH**

**TRANSFORMER (1/2)**

**TRANSFORMER (2/2)**

**CONNECTOR**

**POWER SWITCH**

Ref. No.	Part No.	Description	Remark		
		< IC >			
IC1	8-752-056-51	IC CXA1417Q			
		< RESISTOR >			
R1	1-216-615-11	METAL CHIP	33	0.5%	1/10W
R2	1-208-806-11	METAL GLAZE	10K	2%	1/10W
R3	1-208-812-11	METAL GLAZE	18K	2%	1/10W
R4	1-216-119-00	METAL CHIP	820K	5%	1/10W
R5	1-208-799-11	METAL GLAZE	5.1K	2%	1/10W
R6	1-208-787-11	METAL GLAZE	1.6K	2%	1/10W
R7	1-216-657-11	METAL CHIP	1.8K	0.5%	1/10W
R8	1-216-667-11	METAL CHIP	4.7K	0.5%	1/10W
R9	1-208-791-11	METAL GLAZE	2.4K	2%	1/10W
R10	1-216-052-00	METAL CHIP	1.3K	5%	1/10W
R11	1-216-615-11	METAL CHIP	33	0.5%	1/10W
R12	1-216-619-11	METAL CHIP	47	0.5%	1/10W
R13	1-208-784-11	METAL GLAZE	1.2K	2%	1/10W
R14	1-216-667-11	METAL CHIP	4.7K	0.5%	1/10W
R15	1-208-791-11	METAL GLAZE	2.4K	2%	1/10W
R16	1-216-615-11	METAL CHIP	33	0.5%	1/10W
R17	1-216-619-11	METAL CHIP	47	0.5%	1/10W
R18	1-216-657-11	METAL CHIP	1.8K	0.5%	1/10W
R19	1-208-787-11	METAL GLAZE	1.6K	2%	1/10W
R20	1-208-799-11	METAL GLAZE	5.1K	2%	1/10W
R21	1-216-119-00	METAL CHIP	820K	5%	1/10W
R22	1-216-655-11	METAL CHIP	1.5K	0.5%	1/10W
R23	1-216-678-11	METAL CHIP	13K	0.5%	1/10W
R24	1-216-673-11	METAL CHIP	8.2K	0.5%	1/10W
R25	1-208-806-11	METAL GLAZE	10K	2%	1/10W
R26	1-216-676-11	METAL CHIP	11K	0.5%	1/10W
R27	1-208-799-11	METAL GLAZE	5.1K	2%	1/10W
R28	1-216-695-11	METAL CHIP	68K	0.5%	1/10W
R29	1-208-799-11	METAL GLAZE	5.1K	2%	1/10W
R30	1-208-791-11	METAL GLAZE	2.4K	2%	1/10W
R31	1-208-811-11	METAL GLAZE	16K	2%	1/10W
R32	1-216-685-11	METAL CHIP	27K	0.5%	1/10W
R33	1-208-813-11	METAL GLAZE	20K	2%	1/10W
R34	1-216-684-11	METAL CHIP	24K	0.5%	1/10W
R35	1-208-817-11	METAL GLAZE	30K	2%	1/10W
R36	1-208-817-11	METAL GLAZE	30K	2%	1/10W
R37	1-216-676-11	METAL CHIP	11K	0.5%	1/10W
R38	1-208-819-11	METAL GLAZE	36K	2%	1/10W
R39	1-208-799-11	METAL GLAZE	5.1K	2%	1/10W
R40	1-208-817-11	METAL GLAZE	30K	2%	1/10W
R41	1-208-811-11	METAL GLAZE	16K	2%	1/10W
R42	1-216-673-11	METAL CHIP	8.2K	0.5%	1/10W
R43	1-216-676-11	METAL CHIP	11K	0.5%	1/10W
R44	1-216-689-11	METAL CHIP	39K	0.5%	1/10W

Ref. No.	Part No.	Description	Remark		
R45	1-216-689-11	METAL CHIP	39K	0.5%	1/10W
		*****			
*	1-638-020-11	LEAF SW BOARD			
		*****			
		< CONNECTOR >			
* CNP81	1-568-850-11	SOCKET, CONNECTOR 7P			
		< IC >			
IC81	8-749-924-10	IC PHONT REFLECTOR NJL5165K-B(H1)			
		< RESISTOR >			
R81	1-249-414-11	CARBON	560	5%	1/4W
R82	1-247-818-11	CARBON	300	5%	1/4W
R83	1-247-834-11	CARBON	1.3K	5%	1/4W
R84	1-249-417-11	CARBON	1K	5%	1/4W
R85	1-249-408-11	CARBON	180	5%	1/4W
		< SWITCH >			
S81	1-571-958-11	SWITCH, PUSH (1 KEY) (STOP DET)			
S82	1-571-281-21	SWITCH, LEAF (CrO <sub>2</sub> DET)			
S83	1-571-281-21	SWITCH, LEAF (METAL DET)			
S84	1-571-281-21	SWITCH, LEAF (ERASE PROOF, SIDE A)			
S85	1-571-281-21	SWITCH, LEAF (ERASE PROOF, SIDE B)			
S86	1-571-281-21	SWITCH, LEAF (HALF DET)			
		*****			
*	A-2007-399-A	MAIN BOARD, COMPLETE (US, CND)			
*	A-2007-402-A	MAIN BOARD, COMPLETE (AEP, G)			
*	A-2007-403-A	MAIN BOARD, COMPLETE (E)			
*	A-2007-404-A	MAIN BOARD, COMPLETE (AUS)			
		*****			
		SWITCH BOARD			
		*****			
		TRANSFORMER BOARD (1/2) (EXCEPT E)			
		*****			
		TRANSFORMER BOARD (2/2)			
		*****			
		CONNECTOR BOARD			
		*****			
		POWER SWITCH BOARD			
		*****			
		< CAPACITOR >			
C102	1-126-045-11	ELECT	2.2uF	20%	50V
C103	1-126-163-11	ELECT	4.7uF	20%	50V
C104	1-106-353-00	MYLAR	0.0027uF	5%	50V
C106	1-126-059-11	ELECT	10uF	20%	50V
C107	1-130-495-00	MYLAR	0.1uF	5%	50V

**MAIN**

**SWITCH**

**TRANSFORMER (1/2)**

**TRANSFORMER (2/2)**

**CONNECTOR**

**POWER SWITCH**

Ref.No.	Part No.	Description	Remark
C108	1-130-493-00	MYLAR	0.068uF 5% 50V
C109	1-126-059-11	ELECT	10uF 20% 50V
C110	1-126-043-11	ELECT	0.47uF 20% 50V
C111	1-126-163-11	ELECT	4.7uF 20% 50V
C112	1-126-163-11	ELECT	4.7uF 20% 50V
C114	1-124-925-11	ELECT	2.2uF 20% 100V
C116	1-126-043-11	ELECT	0.47uF 20% 50V
C117	1-126-163-11	ELECT	4.7uF 20% 50V
C123	1-124-916-11	ELECT	22uF 20% 63V
C124	1-124-907-11	ELECT	10uF 20% 50V
C202	1-126-045-11	ELECT	2.2uF 20% 50V
C203	1-126-163-11	ELECT	4.7uF 20% 50V
C204	1-106-353-00	MYLAR	0.0027uF 5% 50V
C206	1-126-059-11	ELECT	10uF 20% 50V
C207	1-130-495-00	MYLAR	0.1uF 5% 50V
C208	1-130-493-00	MYLAR	0.068uF 5% 50V
C209	1-126-059-11	ELECT	10uF 20% 50V
C210	1-126-043-11	ELECT	0.47uF 20% 50V
C211	1-126-163-11	ELECT	4.7uF 20% 50V
C212	1-126-163-11	ELECT	4.7uF 20% 50V
C214	1-124-925-11	ELECT	2.2uF 20% 100V
C216	1-126-043-11	ELECT	0.47uF 20% 50V
C217	1-126-163-11	ELECT	4.7uF 20% 50V
C223	1-124-916-11	ELECT	22uF 20% 63V
C224	1-124-907-11	ELECT	10uF 20% 50V
C301	1-126-963-11	ELECT	4.7uF 20% 50V
C302	1-126-963-11	ELECT	4.7uF 20% 50V
C401	1-126-963-11	ELECT	4.7uF 20% 50V
C402	1-126-963-11	ELECT	4.7uF 20% 50V
C501	1-124-903-11	ELECT	1uF 20% 50V
C502	1-124-902-00	ELECT	0.47uF 20% 50V
C503	1-124-916-11	ELECT	22uF 20% 63V
C504	1-124-903-11	ELECT	1uF 20% 50V
C505	1-130-491-00	MYLAR	0.047uF 5% 50V
C506	1-130-495-00	MYLAR	0.1uF 5% 50V
C507	1-124-907-11	ELECT	10uF 20% 50V
C508	1-124-907-11	ELECT	10uF 20% 50V
C509	1-124-907-11	ELECT	10uF 20% 50V
C510	1-164-159-11	CERAMIC	0.1uF 50V
C511	1-164-159-11	CERAMIC	0.1uF 50V
C512	1-126-916-11	ELECT	1000uF 20% 6.3V
C514	1-124-443-00	ELECT	100uF 20% 10V
C515	1-106-353-00	MYLAR	0.0027uF 5% 50V
C516	1-130-494-11	MYLAR	0.082uF 5% 50V
C517	1-130-491-00	MYLAR	0.047uF 5% 50V
C518	1-106-351-00	MYLAR	2200PF 5% 200V
C521	1-124-916-11	ELECT	22uF 20% 63V
C524	1-124-907-11	ELECT	10uF 20% 50V
C525	1-124-907-11	ELECT	10uF 20% 50V

Ref.No.	Part No.	Description	Remark
C571	1-126-952-11	ELECT	1000uF 20% 16V
C572	1-126-952-11	ELECT	1000uF 20% 16V
C573	1-126-952-11	ELECT	1000uF 20% 16V
C574	1-124-902-00	ELECT	0.47uF 20% 50V
C601	1-164-159-11	CERAMIC	0.1uF 50V
C602	1-164-159-11	CERAMIC	0.1uF 50V
C603	1-162-288-31	CERAMIC	330PF 10% 50V
C604	1-162-288-31	CERAMIC	330PF 10% 50V
C701	1-126-016-11	ELECT	4700uF 20% 16V
C702	1-126-016-11	ELECT	4700uF 20% 16V
C703	1-124-903-11	ELECT	1uF 20% 50V
C704	1-126-969-11	ELECT	220uF 20% 50V
C705	1-126-963-11	ELECT	4.7uF 20% 50V
C706	1-124-762-00	ELECT	4700uF 20% 10V
C707	1-124-473-11	ELECT	1000uF 20% 10V
C708	1-126-963-11	ELECT	4.7uF 20% 50V
C709	1-126-963-11	ELECT	4.7uF 20% 50V
C710	1-126-925-11	ELECT	470uF 20% 10V
C711	1-126-947-11	ELECT	47uF 20% 35V
C712	1-124-916-11	ELECT	22uF 20% 63V
C801	1-126-923-11	ELECT	220uF 20% 10V
C802	1-164-159-11	CERAMIC	0.1uF 50V
C804	1-124-902-00	ELECT	0.47uF 20% 50V
C805	1-161-494-00	CERAMIC	0.022uF 25V
C806	1-161-494-00	CERAMIC	0.022uF 25V
C807	1-161-494-00	CERAMIC	0.022uF 25V
C808	1-161-494-00	CERAMIC	0.022uF 25V
C809	1-161-494-00	CERAMIC	0.022uF 25V
C810	1-164-159-11	CERAMIC	0.1uF 50V
C811	1-164-159-11	CERAMIC	0.1uF 50V
C821	1-124-907-11	ELECT	10uF 20% 50V
C841	1-124-907-11	ELECT	10uF 20% 50V
C861	1-162-294-31	CERAMIC	0.001uF 10% 50V
C862	1-162-294-31	CERAMIC	0.001uF 10% 50V

< CONNECTOR >

CN131	1-695-087-11	PIN, CONNECTOR (PC BOARD) 7P	
CN231	1-695-087-11	PIN, CONNECTOR (PC BOARD) 7P	
* CN501	1-691-916-11	CONNECTOR, BOARD TO BOARD	
* CN502	1-691-916-11	CONNECTOR, BOARD TO BOARD	(CONNECTOR BOARD)
* CN503	1-691-916-11	CONNECTOR, BOARD TO BOARD	
* CN504	1-691-916-11	CONNECTOR, BOARD TO BOARD	
CN505	1-750-414-11	CONNECTOR, FFC/FPC 9P	
CN701	1-766-269-11	PIN, CONNECTOR (PC BOARD) 7P	
CN801	1-506-468-11	PIN, CONNECTOR 3P	
* CN802	1-568-954-11	PIN, CONNECTOR 5P	
* CN803	1-568-954-11	PIN, CONNECTOR 5P	
CN804	1-770-246-11	SOCKET, CONNECTOR 41P	

**MAIN SWITCH TRANSFORMER (1/2)**

**TRANSFORMER (2/2) CONNECTOR POWER SWITCH**

Ref. No.	Part No.	Description	Remark
CN805	1-568-826-11	CONNECTOR, FFC/FPC 7P	
CN806	1-568-826-11	CONNECTOR, FFC/FPC 7P	
CNP505	1-750-414-11	CONNECTOR, FFC/FPC 9P (CONNECTOR BOARD)	
* CNP702	1-580-230-31	PIN, CONNECTOR (PC BOARD) 2P (TRANSFORMER BOARD 1/2) (EXCEPT E)	
< DIODE >			
D151	8-719-933-33	DIODE HZS6A1L	
D251	8-719-933-33	DIODE HZS6A1L	
D301	8-719-987-63	DIODE 1N4148M	
D302	8-719-987-63	DIODE 1N4148M	
D401	8-719-987-63	DIODE 1N4148M	
D402	8-719-987-63	DIODE 1N4148M	
D501	8-719-987-63	DIODE 1N4148M	
D502	8-719-987-63	DIODE 1N4148M	
D504	8-719-200-82	DIODE 11ES2	
D505	8-719-200-82	DIODE 11ES2	
D506	8-719-200-82	DIODE 11ES2	
D507	8-719-200-82	DIODE 11ES2	
D571	8-719-987-63	DIODE 1N4148M	
D572	8-719-987-63	DIODE 1N4148M	
D701	8-719-200-77	DIODE 10E2N	
D702	8-719-200-77	DIODE 10E2N	
D703	8-719-200-77	DIODE 10E2N	
D704	8-719-200-77	DIODE 10E2N	
D705	8-719-987-63	DIODE 1N4148M	
D706	8-719-987-63	DIODE 1N4148M	
D707	8-719-200-77	DIODE 10E2N	
D708	8-719-987-63	DIODE 1N4148M	
D709	8-719-933-33	DIODE HZS6A1L	
D710	8-719-933-33	DIODE HZS6A1L	
D711	8-719-933-33	DIODE HZS6A1L	
D712	8-719-933-39	DIODE HZS6C1L	
D713	8-719-987-63	DIODE 1N4148M	
D714	8-719-987-63	DIODE 1N4148M	
D715	8-719-987-63	DIODE 1N4148M	
D716	8-719-000-78	DIODE UZL-7L2	
D717	8-719-000-78	DIODE UZL-7L2	
D718	8-719-933-33	DIODE HZS6A1L	
D801	8-719-987-63	DIODE 1N4148M	
D802	8-719-987-63	DIODE 1N4148M	
D803	8-719-987-63	DIODE 1N4148M	
D804	8-719-987-63	DIODE 1N4148M	
< IC >			
IC501	8-752-068-63	IC CXA1798Q	
IC502	8-759-634-50	IC M5218AL	

Ref. No.	Part No.	Description	Remark
IC503	8-759-634-51	IC M5218AP	
IC504	8-752-070-67	IC CXA1597P	
IC505	8-759-634-51	IC M5218AP	
IC506	8-759-634-51	IC M5218AP	
IC601	8-759-207-05	IC TA7272P	
IC701	8-759-634-51	IC M5218AP	
IC801	8-752-862-38	IC CXP82220-031Q	
IC802	8-759-000-48	IC MC14052BCP	
IC803	8-759-165-82	IC PST600E-T	
IC804	8-759-000-48	IC MC14052BCP	
IC805	8-759-916-14	IC SN74HC04AN	
IC806	8-759-000-48	IC MC14052BCP	
IC807	8-759-916-14	IC SN74HC04AN	
< JACK >			
J501	1-565-258-11	JACK, PIN 4P (LINE IN/OUT)	
< COIL >			
* L601	1-420-872-00	COIL, AIR-CORE	
* L602	1-420-872-00	COIL, AIR-CORE	
L801	1-408-080-00	INDUCTOR 100uH	
< FILTER >			
LPF101	1-235-175-11	FILTER, LOW PASS	
LPF201	1-235-175-11	FILTER, LOW PASS	
< TRANSISTOR >			
Q101	8-729-900-74	TRANSISTOR DTC143TS	
Q102	8-729-922-37	TRANSISTOR 2SD2144S	
Q201	8-729-900-74	TRANSISTOR DTC143TS	
Q202	8-729-922-37	TRANSISTOR 2SD2144S	
Q301	8-729-620-05	TRANSISTOR 2SC2603-BF	
Q302	8-729-900-74	TRANSISTOR DTC143TS	
Q401	8-729-620-05	TRANSISTOR 2SC2603-BF	
Q402	8-729-900-74	TRANSISTOR DTC143TS	
Q501	8-729-119-76	TRANSISTOR 2SA1175-HFE	
Q502	8-729-620-05	TRANSISTOR 2SC2603-BF	
Q503	8-729-620-05	TRANSISTOR 2SC2603-BF	
Q507	8-729-119-76	TRANSISTOR 2SA1175-HFE	
Q601	8-729-801-93	TRANSISTOR 2SD1387	
Q602	8-729-801-93	TRANSISTOR 2SD1387	
Q603	8-729-900-80	TRANSISTOR DTC114ES	
Q701	8-729-141-83	TRANSISTOR 2SB1094-LK	
Q702	8-729-209-15	TRANSISTOR 2SD2012	
Q703	8-729-141-83	TRANSISTOR 2SB1094-LK	
Q704	8-729-119-78	TRANSISTOR 2SC403SP-51	
Q704	8-729-620-05	TRANSISTOR 2SC2603-BF	

**MAIN**

**SWITCH**

**TRANSFORMER (1/2)**

**TRANSFORMER (2/2)**

**CONNECTOR**

**POWER SWITCH**

Ref. No.	Part No.	Description	Remark
Q705	8-729-900-80	TRANSISTOR DTC114ES	
Q706	8-729-900-80	TRANSISTOR DTC114ES	
Q707	8-729-119-76	TRANSISTOR 2SA1175-HFE	
Q708	8-729-140-04	TRANSISTOR 2SB1116A-L	
Q801	8-729-900-80	TRANSISTOR DTC114ES	
Q802	8-729-900-89	TRANSISTOR DTC144ES	
Q821	8-729-900-61	TRANSISTOR DTA114ES	
Q822	8-729-900-80	TRANSISTOR DTC114ES	
Q823	8-729-119-76	TRANSISTOR 2SA1175-HFE	
Q841	8-729-900-61	TRANSISTOR DTA114ES	
Q842	8-729-900-80	TRANSISTOR DTC114ES	
Q843	8-729-119-76	TRANSISTOR 2SA1175-HFE	
< RESISTOR >			
R101	1-259-452-11	CARBON 10K 5%	1/6W
R102	1-259-484-11	CARBON 220K 5%	1/6W
R103	1-259-440-11	CARBON 3.3K 5%	1/6W
R104	1-247-887-00	CARBON 220K 5%	1/4W
R105	1-259-445-11	CARBON 5.1K 5%	1/6W
R106	1-259-434-11	CARBON 1.8K 5%	1/6W
R107	1-259-436-11	CARBON 2.2K 5%	1/6W
R108	1-259-454-11	CARBON 12K 5%	1/6W
R109	1-259-428-11	CARBON 1K 5%	1/6W
R110	1-249-421-11	CARBON 2.2K 5%	1/4W
R111	1-259-440-11	CARBON 3.3K 5%	1/6W
R114	1-259-452-11	CARBON 10K 5%	1/6W
R115	1-259-442-11	CARBON 3.9K 5%	1/6W
R116	1-259-444-11	CARBON 4.7K 5%	1/6W
R117	1-259-460-11	CARBON 22K 5%	1/6W
R118	1-259-458-11	CARBON 18K 5%	1/6W
R119	1-259-452-11	CARBON 10K 5%	1/6W
R120	1-259-412-11	CARBON 220 5%	1/6W
R121	1-249-417-11	CARBON 1K 5%	1/4W
R122	1-259-452-11	CARBON 10K 5%	1/6W
R123	1-259-440-11	CARBON 3.3K 5%	1/6W
R201	1-259-452-11	CARBON 10K 5%	1/6W
R202	1-259-484-11	CARBON 220K 5%	1/6W
R203	1-259-440-11	CARBON 3.3K 5%	1/6W
R204	1-247-887-00	CARBON 220K 5%	1/4W
R205	1-259-445-11	CARBON 5.1K 5%	1/6W
R206	1-259-434-11	CARBON 1.8K 5%	1/6W
R207	1-259-436-11	CARBON 2.2K 5%	1/6W
R208	1-259-454-11	CARBON 12K 5%	1/6W
R209	1-259-428-11	CARBON 1K 5%	1/6W
R210	1-249-421-11	CARBON 2.2K 5%	1/4W
R211	1-259-440-11	CARBON 3.3K 5%	1/6W
R214	1-259-452-11	CARBON 10K 5%	1/6W
R215	1-259-442-11	CARBON 3.9K 5%	1/6W
R216	1-259-444-11	CARBON 4.7K 5%	1/6W

Ref. No.	Part No.	Description	Remark
R217	1-259-460-11	CARBON 22K 5%	1/6W
R218	1-259-458-11	CARBON 18K 5%	1/6W
R219	1-259-452-11	CARBON 10K 5%	1/6W
R220	1-259-412-11	CARBON 220 5%	1/6W
R221	1-249-417-11	CARBON 1K 5%	1/4W
R222	1-259-452-11	CARBON 10K 5%	1/6W
R223	1-259-440-11	CARBON 3.3K 5%	1/6W
R301	1-249-430-11	CARBON 12K 5%	1/4W
R302	1-249-437-11	CARBON 47K 5%	1/4W
R303	1-249-429-11	CARBON 10K 5%	1/4W
R304	1-249-438-11	CARBON 56K 5%	1/4W
R305	1-249-429-11	CARBON 10K 5%	1/4W
R306	1-249-433-11	CARBON 22K 5%	1/4W
R307	1-249-430-11	CARBON 12K 5%	1/4W
R308	1-249-439-11	CARBON 68K 5%	1/4W
R309	1-249-410-11	CARBON 270 5%	1/4W
R401	1-249-430-11	CARBON 12K 5%	1/4W
R402	1-249-437-11	CARBON 47K 5%	1/4W
R403	1-249-429-11	CARBON 10K 5%	1/4W
R404	1-249-438-11	CARBON 56K 5%	1/4W
R405	1-249-429-11	CARBON 10K 5%	1/4W
R406	1-249-433-11	CARBON 22K 5%	1/4W
R407	1-249-430-11	CARBON 12K 5%	1/4W
R408	1-249-439-11	CARBON 68K 5%	1/4W
R409	1-249-410-11	CARBON 270 5%	1/4W
R501	1-215-452-00	METAL 20K 1%	1/4W
R502	1-215-455-00	METAL 27K 1%	1/4W
R509	1-249-417-11	CARBON 1K 5%	1/4W
R510	1-249-413-11	CARBON 470 5%	1/4W
R511	1-249-429-11	CARBON 10K 5%	1/4W
R512	1-249-417-11	CARBON 1K 5%	1/4W
R513	1-249-428-11	CARBON 8.2K 5%	1/4W
R514	1-247-903-00	CARBON 1M 5%	1/4W
R515	1-249-417-11	CARBON 1K 5%	1/4W
R516	1-249-417-11	CARBON 1K 5%	1/4W
R517	1-249-413-11	CARBON 470 5%	1/4W
R519	1-249-437-11	CARBON 47K 5%	1/4W
R520	1-249-429-11	CARBON 10K 5%	1/4W
R521	1-249-433-11	CARBON 22K 5%	1/4W
R522	1-249-426-11	CARBON 5.6K 5%	1/4W
R523	1-249-436-11	CARBON 39K 5%	1/4W
R524	1-249-441-11	CARBON 100K 5%	1/4W
R525	1-249-441-11	CARBON 100K 5%	1/4W
R526	1-249-424-11	CARBON 3.9K 5%	1/4W
R527	1-249-425-11	CARBON 4.7K 5%	1/4W
R528	1-249-425-11	CARBON 4.7K 5%	1/4W
R529	1-249-413-11	CARBON 470 5%	1/4W
R530	1-249-429-11	CARBON 10K 5%	1/4W
R531	1-215-455-00	METAL 27K 1%	1/4W

**MAIN SWITCH TRANSFORMER (1/2)**

**TRANSFORMER (2/2) CONNECTOR POWER SWITCH**

Ref. No.	Part No.	Description	Remark			Ref. No.	Part No.	Description	Remark		
R533	1-249-426-11	CARBON	5. 6K	5%	1/4W	R713	1-249-417-11	CARBON	1K	5%	1/4W
R534	1-249-418-11	CARBON	1. 2K	5%	1/4W	R714	1-249-429-11	CARBON	10K	5%	1/4W
R535	1-249-427-11	CARBON	6. 8K	5%	1/4W	R715	1-249-422-11	CARBON	2. 7K	5%	1/4W
R537	1-247-852-11	CARBON	7. 5K	5%	1/4W	R716	1-249-433-11	CARBON	22K	5%	1/4W
R538	1-249-430-11	CARBON	12K	5%	1/4W	R717	1-249-429-11	CARBON	10K	5%	1/4W
R539	1-249-428-11	CARBON	8. 2K	5%	1/4W	R718	1-249-436-11	CARBON	39K	5%	1/4W
R540	1-249-428-11	CARBON	8. 2K	5%	1/4W	R719	1-249-430-11	CARBON	12K	5%	1/4W
R541	1-249-422-11	CARBON	2. 7K	5%	1/4W	△R720	1-219-136-11	FUSIBLE	0. 22	10%	1/4W F
R542	1-249-426-11	CARBON	5. 6K	5%	1/4W	R721	1-249-419-11	CARBON	1. 5K	5%	1/4W F
R543	1-249-425-11	CARBON	4. 7K	5%	1/4W	△R722	1-219-137-11	FUSIBLE	0. 33	10%	1/4W F
R544	1-249-425-11	CARBON	4. 7K	5%	1/4W	△R723	1-219-137-11	FUSIBLE	0. 33	10%	1/4W F
R545	1-247-852-11	CARBON	7. 5K	5%	1/4W	R724	1-249-409-11	CARBON	220	5%	1/4W
R546	1-249-430-11	CARBON	12K	5%	1/4W	R801	1-249-441-11	CARBON	100K	5%	1/4W
R549	1-249-428-11	CARBON	8. 2K	5%	1/4W	R802	1-249-417-11	CARBON	1K	5%	1/4W
R550	1-249-428-11	CARBON	8. 2K	5%	1/4W	R803	1-249-435-11	CARBON	33K	5%	1/4W
R551	1-249-422-11	CARBON	2. 7K	5%	1/4W	R804	1-247-807-31	CARBON	100	5%	1/4W
R552	1-249-426-11	CARBON	5. 6K	5%	1/4W	R805	1-247-807-31	CARBON	100	5%	1/4W
R553	1-249-441-11	CARBON	100K	5%	1/4W	R806	1-247-807-31	CARBON	100	5%	1/4W
R554	1-249-429-11	CARBON	10K	5%	1/4W	R807	1-247-807-31	CARBON	100	5%	1/4W
R555	1-260-079-11	CARBON	22	5%	1/2W	R808	1-249-429-11	CARBON	10K	5%	1/4W
R556	1-260-079-11	CARBON	22	5%	1/2W	R809	1-249-429-11	CARBON	10K	5%	1/4W
R557	1-247-858-11	CARBON	13K	5%	1/4W	R810	1-247-807-31	CARBON	100	5%	1/4W
R558	1-249-431-11	CARBON	15K	5%	1/4W	R811	1-247-807-31	CARBON	100	5%	1/4W
R601	1-247-807-31	CARBON	100	5%	1/4W	R812	1-247-807-31	CARBON	100	5%	1/4W
R602	1-247-807-31	CARBON	100	5%	1/4W	R813	1-247-807-31	CARBON	100	5%	1/4W
R603	1-249-433-11	CARBON	22K	5%	1/4W	R814	1-249-429-11	CARBON	10K	5%	1/4W
R604	1-249-433-11	CARBON	22K	5%	1/4W	R815	1-249-429-11	CARBON	10K	5%	1/4W
R605	1-249-433-11	CARBON	22K	5%	1/4W	R816	1-249-429-11	CARBON	10K	5%	1/4W
R606	1-249-433-11	CARBON	22K	5%	1/4W	R817	1-247-807-31	CARBON	100	5%	1/4W
R607	1-249-430-11	CARBON	12K	5%	1/4W	R818	1-249-441-11	CARBON	100K	5%	1/4W
R608	1-249-430-11	CARBON	12K	5%	1/4W	R819	1-249-441-11	CARBON	100K	5%	1/4W
R609	1-249-433-11	CARBON	22K	5%	1/4W	R821	1-249-432-11	CARBON	18K	5%	1/4W
R610	1-249-433-11	CARBON	22K	5%	1/4W	R822	1-247-854-11	CARBON	9. 1K	5%	1/4W
R611	1-249-421-11	CARBON	2. 2K	5%	1/4W	R824	1-249-421-11	CARBON	2. 2K	5%	1/4W
R612	1-249-421-11	CARBON	2. 2K	5%	1/4W	R825	1-247-852-11	CARBON	7. 5K	5%	1/4W
R613	1-249-429-11	CARBON	10K	5%	1/4W	R826	1-249-431-11	CARBON	15K	5%	1/4W
R614	1-249-429-11	CARBON	10K	5%	1/4W	R827	1-247-866-11	CARBON	30K	5%	1/4W
R701	1-249-414-11	CARBON	560	5%	1/4W	R828	1-247-874-11	CARBON	62K	5%	1/4W
R702	1-249-429-11	CARBON	10K	5%	1/4W	R829	1-249-429-11	CARBON	10K	5%	1/4W
R703	1-249-419-11	CARBON	1. 5K	5%	1/4W	R830	1-249-429-11	CARBON	10K	5%	1/4W
R704	1-249-425-11	CARBON	4. 7K	5%	1/4W	R831	1-249-429-11	CARBON	10K	5%	1/4W
R705	1-249-427-11	CARBON	6. 8K	5%	1/4W	R832	1-249-429-11	CARBON	10K	5%	1/4W
R706	1-249-419-11	CARBON	1. 5K	5%	1/4W	R833	1-249-434-11	CARBON	27K	5%	1/4W
R707	1-249-429-11	CARBON	10K	5%	1/4W	R834	1-249-434-11	CARBON	27K	5%	1/4W
R708	1-249-419-11	CARBON	1. 5K	5%	1/4W	R835	1-249-434-11	CARBON	27K	5%	1/4W
R709	1-249-425-11	CARBON	4. 7K	5%	1/4W	R836	1-249-434-11	CARBON	27K	5%	1/4W
R710	1-249-417-11	CARBON	1K	5%	1/4W	R837	1-249-422-11	CARBON	2. 7K	5%	1/4W
R711	1-249-427-11	CARBON	6. 8K	5%	1/4W	R838	1-249-422-11	CARBON	2. 7K	5%	1/4W
R712	1-249-427-11	CARBON	6. 8K	5%	1/4W	R839	1-249-422-11	CARBON	2. 7K	5%	1/4W

<p>The components identified by mark <math>\Delta</math> or dotted line with mark <math>\Delta</math> are critical for safety. Replace only with part number specified.</p>	<p>Les composants identifiés par une marque <math>\Delta</math> sont critiques pour la sécurité. Ne les remplacer que par une pièce portant le numéro spécifié.</p>
---	---

**MAIN**

**SWITCH**

**TRANSFORMER (1/2)**

**TRANSFORMER (2/2)**

**CONNECTOR**

**POWER SWITCH**

**PANEL**

**HEADPHONE**

Ref. No.	Part No.	Description	Remark
R841	1-249-432-11	CARBON	18K 5% 1/4W
R842	1-247-854-11	CARBON	9.1K 5% 1/4W
R844	1-249-421-11	CARBON	2.2K 5% 1/4W
R845	1-247-852-11	CARBON	7.5K 5% 1/4W
R846	1-249-431-11	CARBON	15K 5% 1/4W
R847	1-247-866-11	CARBON	30K 5% 1/4W
R848	1-247-874-11	CARBON	62K 5% 1/4W
R849	1-249-429-11	CARBON	10K 5% 1/4W
R850	1-249-429-11	CARBON	10K 5% 1/4W
R851	1-249-429-11	CARBON	10K 5% 1/4W
R852	1-249-429-11	CARBON	10K 5% 1/4W
R853	1-249-434-11	CARBON	27K 5% 1/4W
R854	1-249-434-11	CARBON	27K 5% 1/4W
R855	1-249-434-11	CARBON	27K 5% 1/4W
R856	1-249-434-11	CARBON	27K 5% 1/4W
R857	1-249-422-11	CARBON	2.7K 5% 1/4W
R858	1-249-422-11	CARBON	2.7K 5% 1/4W
R859	1-249-422-11	CARBON	2.7K 5% 1/4W
R860	1-249-433-11	CARBON	22K 5% 1/4W
R861	1-249-421-11	CARBON	2.2K 5% 1/4W
R862	1-249-421-11	CARBON	2.2K 5% 1/4W
R863	1-249-421-11	CARBON	2.2K 5% 1/4W
R864	1-249-434-11	CARBON	27K 5% 1/4W
R865	1-249-421-11	CARBON	2.2K 5% 1/4W
R866	1-249-421-11	CARBON	2.2K 5% 1/4W
R867	1-249-421-11	CARBON	2.2K 5% 1/4W
R868	1-249-434-11	CARBON	27K 5% 1/4W
R869	1-249-421-11	CARBON	2.2K 5% 1/4W
R870	1-249-421-11	CARBON	2.2K 5% 1/4W
R871	1-249-433-11	CARBON	22K 5% 1/4W
R872	1-249-429-11	CARBON	10K 5% 1/4W
R873	1-249-433-11	CARBON	22K 5% 1/4W
R874	1-249-429-11	CARBON	10K 5% 1/4W
R875	1-249-433-11	CARBON	22K 5% 1/4W
R876	1-249-433-11	CARBON	22K 5% 1/4W
R877	1-249-433-11	CARBON	22K 5% 1/4W
R878	1-249-433-11	CARBON	22K 5% 1/4W
R879	1-247-807-31	CARBON	100 5% 1/4W
R935	1-249-427-11	CARBON	6.8K 5% 1/4W
R936	1-249-431-11	CARBON	15K 5% 1/4W
R945	1-249-427-11	CARBON	6.8K 5% 1/4W
RV101	1-241-630-11	RES, ADJ, CARBON 10K	(REC LEVEL, L) (DECK B)

Ref. No.	Part No.	Description	Remark
RV102	1-241-630-11	RES, ADJ, CARBON 10K	(REC LEVEL, L) (DECK A)
RV201	1-241-630-11	RES, ADJ, CARBON 10K	(REC LEVEL, R) (DECK B)
RV202	1-241-630-11	RES, ADJ, CARBON 10K	(REC LEVEL, R) (DECK A)
S801	1-554-118-00	SWITCH, PUSH (1 KEY) (POWER)	(POWER SWITCH BOARD)
S935	1-570-837-11	SWITCH, SLIDE (DOLBY NR)	(SWITCH BOARD)
S936	1-570-855-11	SWITCH, SLIDE (DOLBY NR)	(SWITCH BOARD)
S945	1-570-855-11	SWITCH, SLIDE (DIR MODE)	(SWITCH BOARD)
* TP501	1-564-506-11	PLUG, CONNECTOR 3P	
* TP801	1-564-505-11	PLUG, CONNECTOR 2P	
X801	1-579-175-11	VIBRATOR, CERAMIC (10MHz)	
* A-2007-400-A		PANEL BOARD, COMPLETE	
		*****	
		HEADPHONE BOARD	
		*****	
C303	1-162-294-31	CERAMIC	0.001uF 10% 50V (HEADPHONE BOARD)
C403	1-162-294-31	CERAMIC	0.001uF 10% 50V (HEADPHONE BOARD)
CNP804	1-770-247-11	SOCKET, CONNECTOR 41P	
IC901	8-741-810-59	IC SBX1810-59	
J801	1-507-796-71	JACK (PHONES)	(HEADPHONE BOARD)
R901	1-249-413-11	CARBON	470 5% 1/4W
R902	1-247-807-31	CARBON	100 5% 1/4W
R911	1-249-418-11	CARBON	1.2K 5% 1/4W
R912	1-249-420-11	CARBON	1.8K 5% 1/4W
R913	1-249-422-11	CARBON	2.7K 5% 1/4W

# PANEL

# HEADPHONE

Ref.No.	Part No.	Description	Remark
R914	1-249-424-11	CARBON	3. 9K 5% 1/4W
R915	1-249-427-11	CARBON	6. 8K 5% 1/4W
R916	1-249-431-11	CARBON	15K 5% 1/4W
R917	1-249-437-11	CARBON	47K 5% 1/4W
R921	1-249-418-11	CARBON	1. 2K 5% 1/4W
R922	1-249-420-11	CARBON	1. 8K 5% 1/4W
R923	1-249-422-11	CARBON	2. 7K 5% 1/4W
R924	1-249-424-11	CARBON	3. 9K 5% 1/4W
R925	1-249-427-11	CARBON	6. 8K 5% 1/4W
R926	1-249-431-11	CARBON	15K 5% 1/4W
R927	1-249-437-11	CARBON	47K 5% 1/4W
R931	1-249-418-11	CARBON	1. 2K 5% 1/4W
R932	1-249-420-11	CARBON	1. 8K 5% 1/4W
R933	1-249-422-11	CARBON	2. 7K 5% 1/4W
R934	1-249-424-11	CARBON	3. 9K 5% 1/4W
R941	1-249-418-11	CARBON	1. 2K 5% 1/4W
R942	1-249-420-11	CARBON	1. 8K 5% 1/4W
R943	1-249-422-11	CARBON	2. 7K 5% 1/4W
R944	1-249-424-11	CARBON	3. 9K 5% 1/4W
R951	1-249-418-11	CARBON	1. 2K 5% 1/4W
R952	1-249-420-11	CARBON	1. 8K 5% 1/4W
R953	1-249-422-11	CARBON	2. 7K 5% 1/4W
< VARIABLE RESISTOR >			
RV901	1-241-798-11	RES, VAR, CARBON 20K (BALANCE)	
RV902	1-241-797-11	RES, VAR, CARBON 20K (REC LEVEL)	
< SWITCH >			
S911	1-554-303-21	SWITCH, TACTILE (■ CLEAR)	
S912	1-554-303-21	SWITCH, TACTILE (▨)	
S913	1-554-303-21	SWITCH, TACTILE (▷ FRONT)	
S914	1-554-303-21	SWITCH, TACTILE (◁ BACK)	
S915	1-554-303-21	SWITCH, TACTILE (●)	
S916	1-554-303-21	SWITCH, TACTILE (◀ AMS)	
S917	1-554-303-21	SWITCH, TACTILE (AMS ▶▶)	
S918	1-554-303-21	SWITCH, TACTILE (●)	
S921	1-554-303-21	SWITCH, TACTILE (■)	
S922	1-554-303-21	SWITCH, TACTILE (▨)	
S923	1-554-303-21	SWITCH, TACTILE (▷)	
S924	1-554-303-21	SWITCH, TACTILE (◁)	
S925	1-554-303-21	SWITCH, TACTILE (●)	
S926	1-554-303-21	SWITCH, TACTILE (◀ AMS)	
S927	1-554-303-21	SWITCH, TACTILE (AMS ▶▶)	
S928	1-554-303-21	SWITCH, TACTILE (●)	
S931	1-554-303-21	SWITCH, TACTILE (RESET)	
S932	1-554-303-21	SWITCH, TACTILE (MEMORY)	
S933	1-554-303-21	SWITCH, TACTILE (AUTO CAL, DECK A)	
S934	1-554-303-21	SWITCH, TACTILE (AUTO CAL, DECK B)	

Ref.No.	Part No.	Description	Remark
S941	1-554-303-21	SWITCH, TACTILE (DUBBING, HIGH/NORM)	
S942	1-554-303-21	SWITCH, TACTILE (A+B REC)	
S943	1-554-303-21	SWITCH, TACTILE (RESET)	
S944	1-554-303-21	SWITCH, TACTILE (MEMORY)	
S951	1-554-303-21	SWITCH, TACTILE (RMS/START)	
S952	1-554-303-21	SWITCH, TACTILE (SET)	
S953	1-554-303-21	SWITCH, TACTILE (CHECK)	
S954	1-554-303-21	SWITCH, TACTILE (DISPLAY)	
< INDICATOR TUBE >			
VFD901	1-517-263-11	INDICATOR TUBE, FLUORESCENT	
*****			
MISCELLANEOUS			
*****			
3	1-575-849-11	WIRE, FLAT TYPE (9 CORE)	
△6	1-551-188-XX	CORD, POWER (E)	
△6	1-558-945-21	CORD, POWER (POLAR. SPT-1) (US, CND)	
△6	1-575-651-21	CORD, POWER (AEP, G)	
△6	1-696-845-11	CORD, POWER (AUS)	
15	1-569-007-11	ADAPTER, CONVERSION 2P (E)	
58	1-775-307-21	WIRE (FLAT TYPE) (7 CORE)	
69	1-769-598-11	WIRE (FLAT TYPE) (41 CORE)	
73	1-775-308-11	WIRE (FLAT TYPE) (7 CORE)	
121	1-638-983-11	PC BOARD, MOTOR FLEXIBLE	
HRPE101A-2003-930-A	BASE ASSY, HEAD (RECORD/PLAYBACK/ERASE)		
M1	X-3365-377-2	MOTOR ASSY (CAPSTAN) (DECK A)	
M1	X-3365-377-2	MOTOR ASSY (CAPSTAN) (DECK B)	
M2	X-3363-501-2	MOTOR ASSY (REEL) (DECK A)	
M2	X-3363-501-2	MOTOR ASSY (REEL) (DECK B)	
△S701	1-692-155-11	SELECTOR, POWER VOLTAGE (VOLTAGE SELECTOR) (E)	
△T701	1-426-784-11	TRANSFORMER, POWER (US, CND)	
△T701	1-426-785-11	TRANSFORMER, POWER (AEP, G, AUS)	
△T701	1-426-910-11	TRANSFORMER, POWER (E)	
*****			
ACCESSORIES & PACKING MATERIALS			
*****			
	1-465-738-11	REMOTE COMMANDER (RM-J902) (CND)	
	1-558-271-11	CORD, CONNECTION	
	2-181-754-01	COVER, BATTERY (For RM-J902) (CND)	
*	3-376-446-01	CUSHION	
	3-755-288-11	MANUAL, INSTRUCTION (RM) (ENGLISH, FRENCH) (CND)	
	3-800-078-11	MANUAL, INSTRUCTION (ENGLISH, FRENCH, SPANISH, PORTUGUESE) (AEP, E)	
	3-800-078-21	MANUAL, INSTRUCTION (ENGLISH) (US, CND, AUS)	

<p>The components identified by mark △ or dotted line with mark △ are critical for safety. Replace only with part number specified.</p>	<p>Les composants identifiés par une marque △ sont critiques pour la sécurité. Ne les remplacer que par une pièce portant le numéro spécifié.</p>
---	---

Ref. No.	Part No.	Description	Remark
	3-800-078-31	MANUAL, INSTRUCTION (FRENCH) (CND)	
	3-800-078-41	MANUAL, INSTRUCTION (GERMAN, DUTCH, SWEDISH, ITALIAN) (AEP)	
	3-800-078-51	MANUAL, INSTRUCTION (GERMAN) (G)	
*	3-925-712-01	INDIVIDUAL CARTON (WA8ES)	
*	3-925-712-11	INDIVIDUAL CARTON (WR765S)	

\*\*\*\*\*

\*\*\*\*\*  
**HARDWARE LIST**  
 \*\*\*\*\*

#1	7-682-548-09	SCREW +BVTT 3×8 (S)
#2	7-685-871-01	SCREW +BVTT 3×6 (S)
#3	7-685-646-79	SCREW +BVTP 3×8 TYPE2 IT-3
#4	7-685-134-19	SCREW +PTPWH (2.6×8)
#5	7-621-773-95	SCREW +BVTT 2.6×6 (S)
#6	7-627-556-08	SCREW +P 2.6×2.8
#7	7-621-775-00	SCREW +B 2.6×3



# TC-WA8ES/WR765S

## SONY SERVICE MANUAL

US Model  
Canadian Model  
TC-WA8ES

AEP Model  
E Model  
Australian Model  
TC-WR765S

## SUPPLEMENT-1

File this Supplement with the Service Manual.

Subject : CHANGE OF HEADPHONE BOARD  
(1-656-360-11 ⇒ 1-656-360-14)

(ECN-TC500627)

● LOCATION 1-J, 1-2

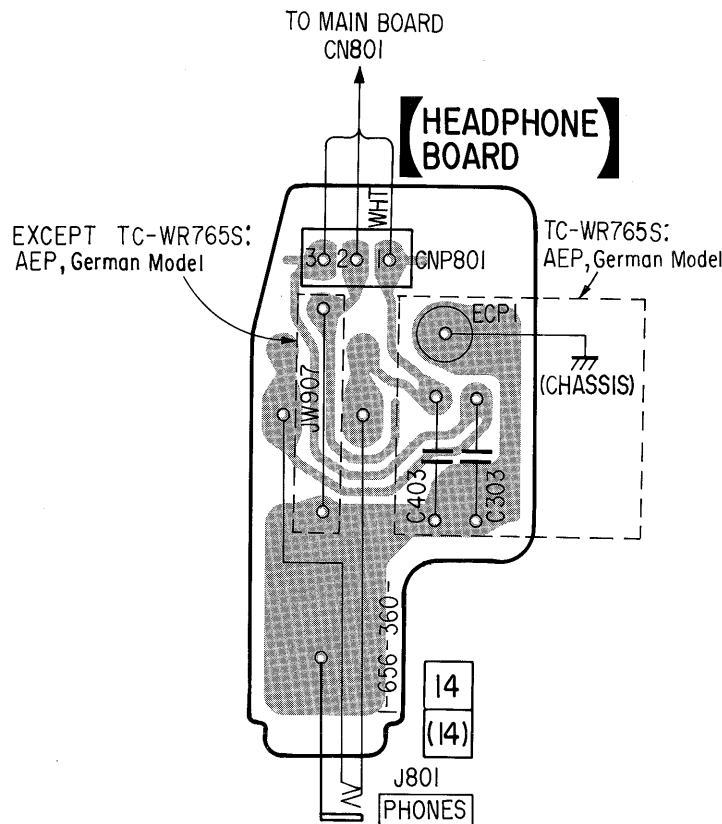

		Former (1-656-360-11)				New (1-656-360-14)				
Ref. No.	Part No.	Description				Part No.	Description			
C303	1-162-294-31	CERAMIC	0.001uF	10%	50V	1-162-294-31	CERAMIC	0.001uF	10%	50V (TC-WR765S: AEP, German)
C403	1-162-294-31	CERAMIC	0.001uF	10%	50V	1-162-294-31	CERAMIC	0.001uF	10%	50V (TC-WR765S: AEP, German)
ECPI						1-765-469-11	LEAD WITH CONNECTOR	(TC-WR765S: AEP, German)		