

TC-WE625/WE725/ WE825S

SERVICE MANUAL



Photo: TC-WE825S

US Model

TC-WE625/WE825S

Canadian Model

TC-WE625

AEP Model

UK Model

TC-WE725/WE825S

E Model

Australian Model

Chinese Model

TC-WE625

Dolby noise reduction extension manufactured under license from Dolby Laboratories Licensing Corporation.
HX Pro originated by Bang & Olufsen. "DOLBY", the double-D symbol \square and "HX PRO" are trademarks of Dolby Laboratories Licensing Corporation.

Model Name Using Similar Mechanism		TC-WE505/WE605S/WE705S
Tape Transport Mechanism Type	DECK A	TC-WE625 : TCM-190RB12CL TC-WE725/WE825S : TCM-190RB13C
	DECK B	TC-WE625 : TCM-190RB12CL TC-WE725/WE825S : TCM-190RB11C

SPECIFICATIONS

System

Recording system

4-track 2-channel stereo

Fast-winding time (approx.)

90 sec. (with Sony C-60 cassette)

High-speed fast-winding time (approx.) (TC-WE825S and TC-WE725 only)

45 sec. (with Sony C-60 cassette)

Bias

AC bias

Signal-to-noise ratio (at peak level and weighted with Dolby NR off)

Type I tape, Sony Type I (NORMAL): 55 dB

Type II tape, Sony Type II (HIGH): 57 dB

Type IV tape, Sony Type IV (METAL): 58 dB

S/N ratio improvement (approximate values)

With Dolby B NR on: 5 dB at 1 kHz, 10 dB at 5 kHz

With Dolby C NR on: 15 dB at 500 Hz, 20 dB at 1 kHz

With Dolby S NR on (TC-WE825S only): 10 dB at 100 Hz, 24 dB at 1 kHz

Harmonic distortion

0.4% (with Type I tape, Sony Type I (NORMAL):

160 nWb/m 315 Hz, 3rd H.D.)

1.8% (with Type IV tape, Sony Type IV (METAL):

250 nWb/m 315 Hz, 3rd H.D.)

Frequency response (Dolby NR off)

Tape type

Type I tape, Sony Type I (NORMAL) 30-16,000 Hz (± 3 dB, IEC),
20-17,000 Hz (± 6 dB)

Type II tape, Sony Type II (HIGH) 30-17,000 Hz (± 3 dB, IEC),
20-18,000 Hz (± 6 dB)

Type IV tape, Sony Type IV (METAL) 30-19,000 Hz (± 3 dB, IEC),
20-20,000 Hz (± 6 dB),
30-13,000 Hz (± 3 dB, -4 dB recording)

- Continued on next page -

STEREO CASSETTE DECK

SONY®



Wow and flutter

± 0.13% W. Peak (IEC)
0.07% W. RMS (NAB)
± 0.18% W. Peak (DIN)

Variable pitch range (approx.)

-30 to +30%

Inputs

Line inputs (phono jacks)

Sensitivity : 0.16 V
Input impedance : 47 kilohms

Outputs

Line outputs (phono jacks)

Rated output level : 0.5 V at a load impedance of
47 kilohms
Load impedance : Over 10 kilohms

Headphones (stereo phono jack)

Output level : 0.25 mW at a load impedance of
32 ohms

General

Power requirements

Where purchased	Power requirements
US, Canadian	120 V AC, 60 Hz
AEP, UK, Chinese	220 - 230 V AC, 50/60 Hz
Australian	240 V AC, 50/60 Hz
Singapore, Malaysia	120/220/230 - 240 V AC, 50/60 Hz

Power consumption
30 W

Dimensions (approx.) (w/h/d)

Model for UK and Australian :
430 × 120 × 310 mm (w/h/d)
(17 × 4 3/4 × 12 1/4 in.)

Model for other countries :
430 × 120 × 290 mm (w/h/d)
including projecting parts and controls

Mass (approx.)

4.3 kg (9 lbs 8 oz)

Supplied accessories

Audio connecting cords (2 phono plugs - 2 phono
plugs) (2)
CONTROL A1 cord (supplied for Canadian models
only) (1)

*Design and specifications are subject to change without
notice.*

SAFETY CHECK-OUT

After correcting the original service problem, perform the following safety check before releasing the set to the customer: Check the antenna terminals, metal trim, "metallized" knobs, screws, and all other exposed metal parts for AC leakage. Check leakage as described below.

LEAKAGE TEST

The AC leakage from any exposed metal part to earth ground and from all exposed metal parts to any exposed metal part having a return to chassis, must not exceed 0.5 mA (500 microamperes). Leakage current can be measured by any one of three methods.

1. A commercial leakage tester, such as the Simpson 229 or RCA WT-540A. Follow the manufacturers' instructions to use these instruments.
2. A battery-operated AC milliammeter. The Data Precision 245 digital multimeter is suitable for this job.
3. Measuring the voltage drop across a resistor by means of a VOM or battery-operated AC voltmeter. The "limit" indication is 0.75 V, so analog meters must have an accurate low-voltage scale. The Simpson 250 and Sanwa SH-63Trd are examples of a passive VOM that is suitable. Nearly all battery operated digital multimeters that have a 2V AC range are suitable. (See Fig. A)

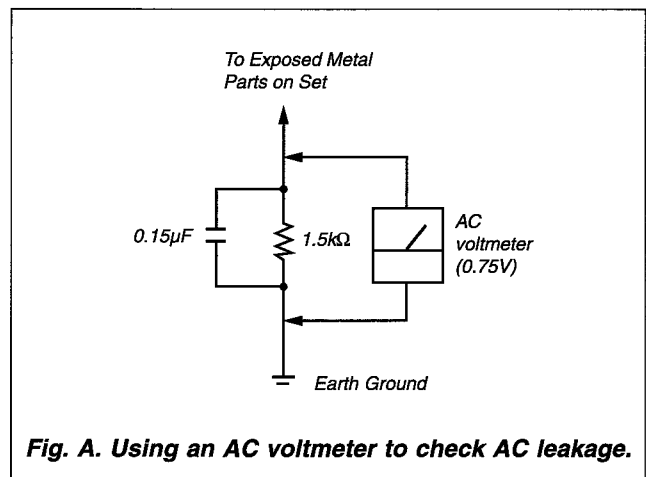

Fig. A. Using an AC voltmeter to check AC leakage.

SAFETY-RELATED COMPONENT WARNING!!

COMPONENTS IDENTIFIED BY MARK Δ OR DOTTED LINE WITH MARK Δ ON THE SCHEMATIC DIAGRAMS AND IN THE PARTS LIST ARE CRITICAL TO SAFE OPERATION. REPLACE THESE COMPONENTS WITH SONY PARTS WHOSE PART NUMBERS APPEAR AS SHOWN IN THIS MANUAL OR IN SUPPLEMENTS PUBLISHED BY SONY.

ATTENTION AU COMPOSANT AYANT RAPPORT À LA SÉCURITÉ!!

LES COMPOSANTS IDENTIFIÉS PAR UNE MARQUE Δ SUR LES DIAGRAMMES SCHÉMATIQUES ET LA LISTE DES PIÈCES SONT CRITIQUES POUR LA SÉCURITÉ DE FONCTIONNEMENT. NE REMPLACER CES COMPOSANTS QUE PAR DES PIÈCES SONY DONT LES NUMÉROS SONT DONNÉS DANS CE MANUEL OU DANS LES SUPPLÉMENTS PUBLIÉS PAR SONY.

MODEL IDENTIFICATION

–Back panel–

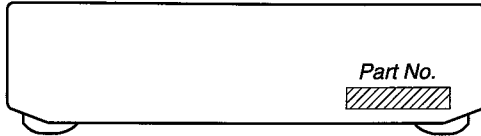

Part No.	Model
3-021-228-0□	TC-WE625 : US model
3-021-228-1□	TC-WE625 : CND model
3-021-228-2□	TC-WE625 : AUS model
3-021-228-3□	TC-WE625 : SP, MY model
3-021-228-4□	TC-WE625 : CH model
3-021-242-0□	TC-WE725 : AEP model
3-021-242-1□	TC-WE725 : UK model
3-021-243-0□	TC-WE825S : AEP model
3-021-243-1□	TC-WE825S : UK model
3-021-243-3□	TC-WE825S : US model

• Abbreviation

CND : Canadian model
 AUS : Austrarian model
 SP : Singapore model
 MY : Malaysia model
 CH : Chinese model

TABLE OF CONTENTS

1. GENERAL

1-1. Location of Controls 4

2. DISASSEMBLY

2-1. Front Panel Assy 5
 2-2. Mechanism Deck 5
 2-3. Fitting Base 6
 2-4. Capstan Motor, Reel Motor 6
 2-5. Head Deck Assy 7

3. MECHANICAL ADJUSTMENTS 8

4. ELECTRICAL ADJUSTMENTS 8

5. DIAGRAMS

5-1. IC Pin Description 12
 5-2. Circuit Boards Location 14
 5-3. Printed Wiring Boards –Main Section– 15
 5-4. Schematic Diagram –Main Section (1/4)– 17
 5-5. Schematic Diagram –Main Section (2/4)– 19
 5-6. Schematic Diagram –Main Section (3/4)– 21
 5-7. Schematic Diagram –Main Section (4/4)– 23
 5-8. Printed Wiring Boards –Power Section– 25
 5-9. Schematic Diagram –Power Section– 26
 5-10. Printed Wiring Boards –Panel Section– 27
 5-11. Schematic Diagram –Panel Section– 29
 5-12. Printed Wiring Boards –Deck A Section– 31
 5-13. Schematic Diagram –Deck A Section– 32
 5-14. Printed Wiring Boards –Deck B Section– 33
 5-15. Schematic Diagram –Deck B Section– 34
 5-16. Printed Wiring Board
 –DOLBY-S Section (TC-WE825S only)– 35
 5-17. Schematic Diagram
 –DOLBY-S Section (TC-WE825S only)– 35

6. EXPLODED VIEWS

6-1. Case Section 38
 6-2. Chassis Section 39
 6-3. Cassette Holder Section 40
 6-4. Front Panel Section 41
 6-5. Tape Mechanism Section 1 42
 6-6. Tape Mechanism Section 2 43

7. ELECTRICAL PARTS LIST 44

SECTION 1 GENERAL

1-1. LOCATION OF CONTROLS

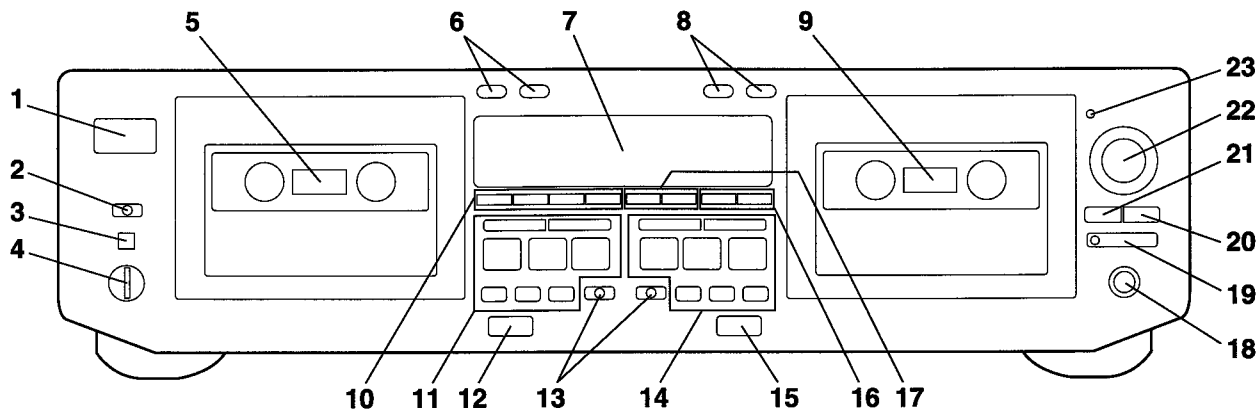

1. I/⏻ (Power) button (US, Canadian)
Ⓚ (Power) button (EXCEPT US, Canadian)
2. DIRECTION MODE switch
3. PITCH CONTROL (⏮ ON/⏭ OFF) switch (TC-WE725/WE825S)
4. PITCH CONTROL knob (TC-WE725/WE825S)
5. Cassette holder (Deck A)
6. COUNTER A buttons (Deck A)
RESET button
MEMORY button
7. Display window
8. COUNTER B buttons (Deck B)
RESET button
MEMORY button
9. Cassette holder (Deck B)
10. RMS buttons
RMS/START button
SET button
CHECK button
DISPLAY button
11. Tape operation buttons (Deck A)
◀ (AMS), RMS - button
▶ (AMS), RMS + button
■ CLEAR (Stop) button
◁ BACK (Reverse play) button
▷ FRONT (Forward play) button
⏸ PAUSE button
○ REC MUTING button
● REC button
12. ⏏ (Eject) button (Deck A)
13. DOLBY NR switches
ON, OFF, FILTER switch
B, C, S switch ("S" use for TC-WE825S)
14. Tape operation buttons (Deck B)
◀ (AMS) button
▶ (AMS) button
■ (Stop) button
◁ (Reverse play) button
▷ (Forward play) button
⏸ PAUSE button
○ REC MUTING button
● REC button
15. ⏏ (Eject) button (Deck B)
16. START (DECK B ⏸) buttons
A+B REC button
HIGH/NORMAL, DUBBING A→B button
17. AUTO CAL (START ⏸) buttons
DECK A button
DECK B button
18. PHONES jack
19. SYNCHRO button and indicator
20. ARL button
21. FADER button
22. REC LEVEL knob
23. AUTO indicator

SECTION 2 DISASSEMBLY

Note : Follow the disassembly procedure in the numerical order given.

CASE

Unscrew the five case attachment screws M3 × 8 and remove the case.

2-1. FRONT PANEL ASSY

POWER VOLTAGE SELECTOR 1 - 2 (Singapore, Malaysia)

FRONT PANEL ASSY 1 - 17

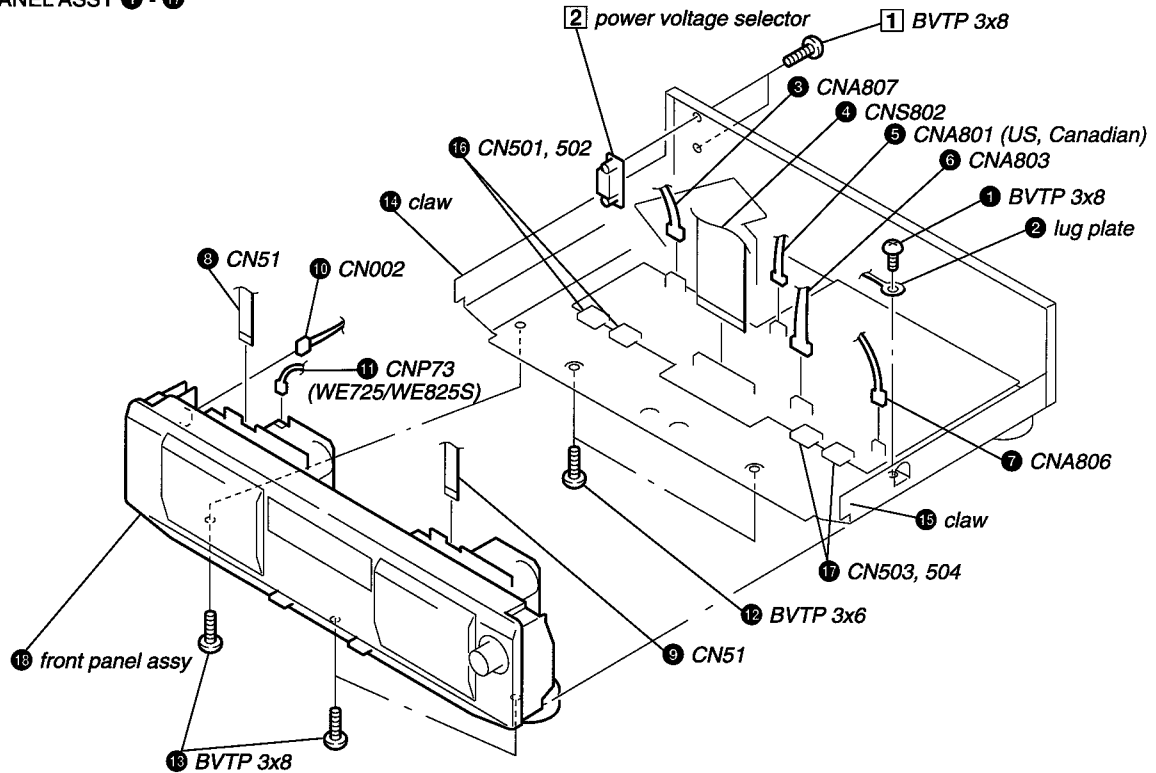

2-2. MECHANISM DECK

1 Press the EJECT button.

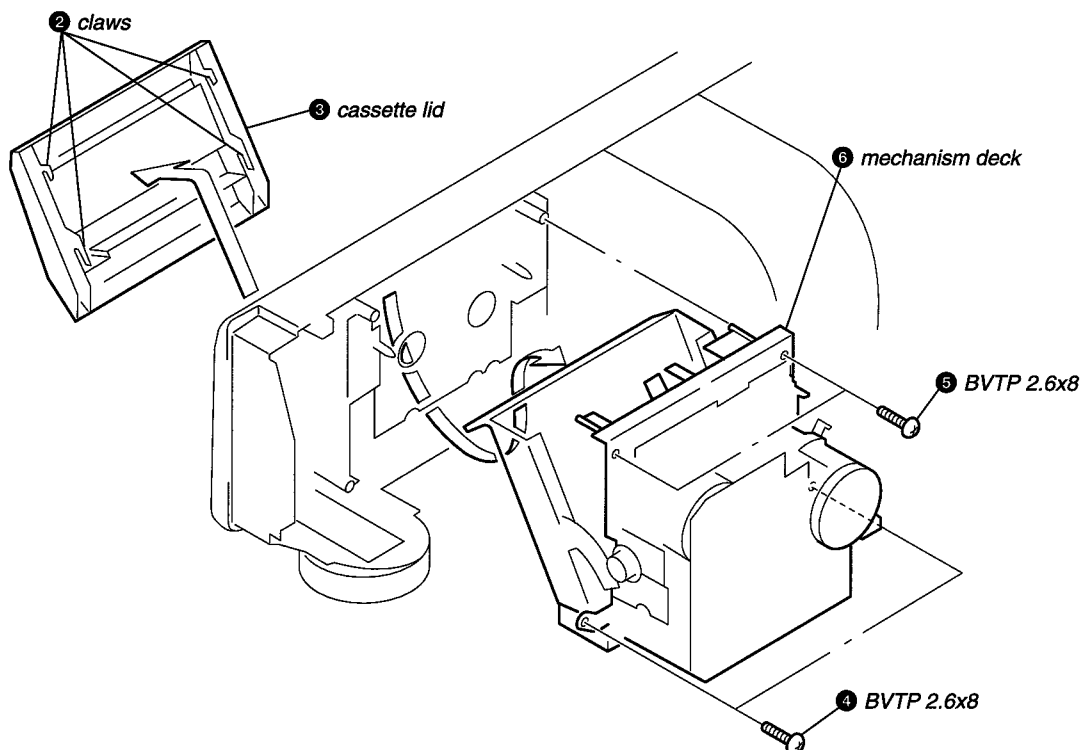

2-3. FITTING BASE

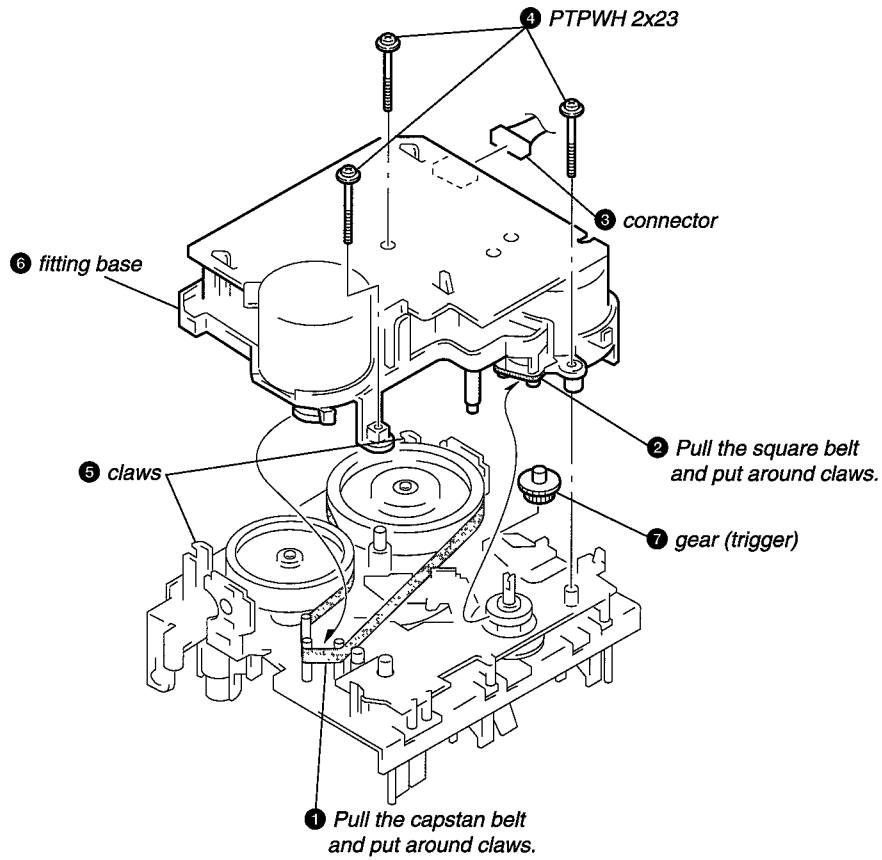

2-4. CAPSTAN MOTOR, REEL MOTOR

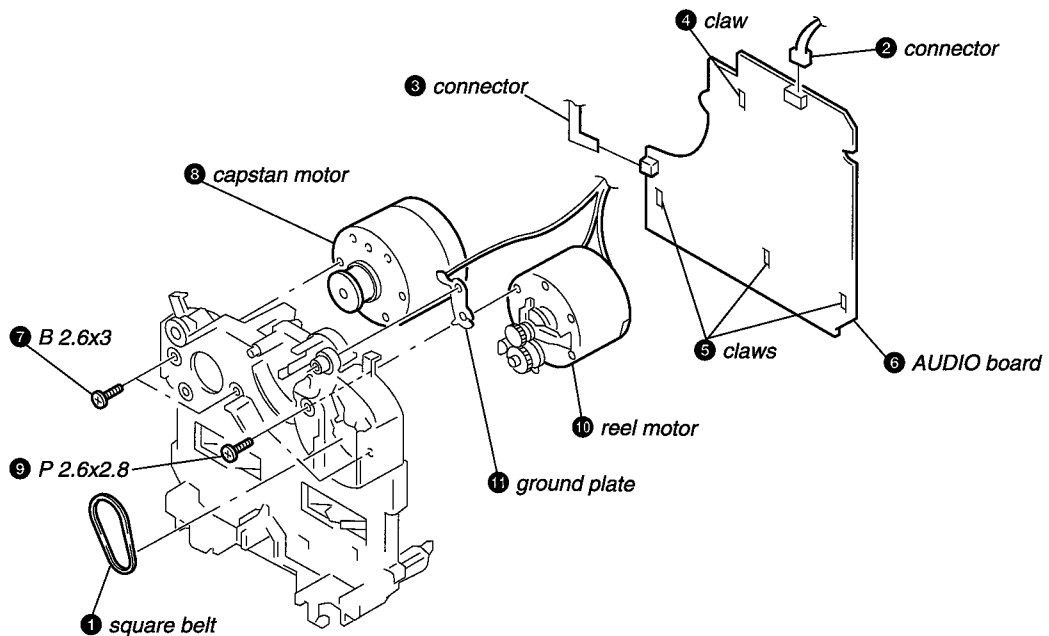

2-5. HEAD DECK ASSY

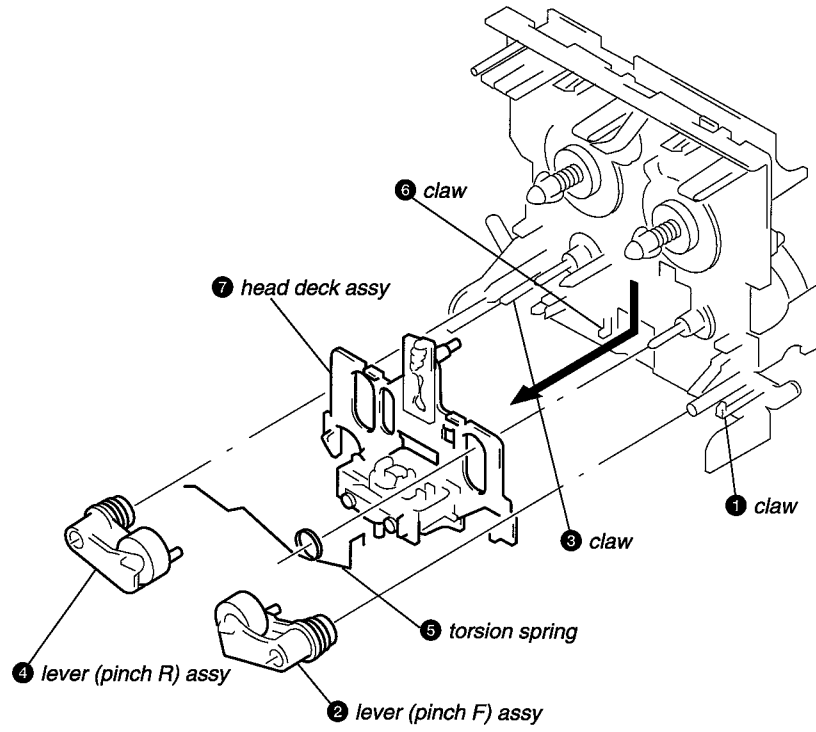

SECTION 3 MECHANICAL ADJUSTMENTS

PRECAUTION

1. Clean the following parts with a denatured alcohol-moistened swab :

record/playback/erase head	pinch roller
rubber belts	capstan
idlers	
2. Demagnetize the record/playback head with a head demagnetizer.
3. Do not use a magnetized screwdriver for the adjustment.
4. After the adjustments, apply suitable locking compound to the parts adjusted.
5. The adjustments should be performed with the rated power supply voltage unless otherwise noted.

Torque Measurement

Mode	Torque meter	Meter reading
Forward	CQ-102C	30 to 65 g • cm (0.42 to 0.90 oz • inch)
Forward back tension	CQ-102C	DECK A : 1 to 6 g • cm (0.014 to 0.083 oz • inch) DECK B : 2 to 9 g • cm (0.028 to 0.125 oz • inch)
Reverse	CQ-102RC	30 to 65 g • cm (0.42 to 0.90 oz • inch)
Reverse back tension	CQ-102RC	1 to 6 g • cm (0.014 to 0.083 oz • inch)
FF/REW	CQ-201B	70 to 120 g • cm (0.97 to 1.67 oz • inch)

SECTION 4 ELECTRICAL ADJUSTMENTS

PRECAUTION

1. The adjustment should be performed in the publication. (Be sure to make playback adjustment at first.)
2. The adjustments and measurement should be performed for both L-CH and R-CH.
 - Switch position
DOLBY NR switch : OFF
DIRECTION MODE switch : \rightleftarrows
 - Standard record position :
Deliver the standard input signal level to input jack and set the REC LEVEL control to obtain the standard output signal level as follows.

– Record Mode –

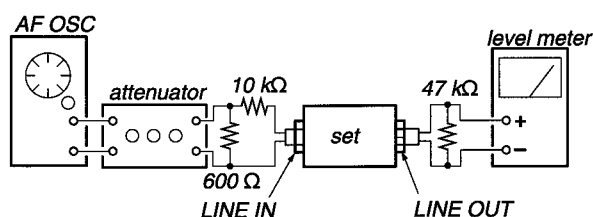

Standard Input Level

Input terminal	LINE IN
source impedance	10 kΩ
input signal level	0.5 V (–3.8 dB)

Standard Output Level

Output terminal	LINE OUT
load impedance	47 kΩ
output signal level	0.5 V (–3.8 dB)

Test Tape

Tape	Contents	Use
P-4-A100	10 kHz, –10 dB	Azimuth Adjustment
WS-48B	3 kHz, 0 dB	Tape Speed Adjustment
P-4-L300	315 Hz, 0 dB	PB Level Adjustment

0 dB = 0.775 V

Test Mode

1. Turn ON power switch pressing “REC MUTING” switch of deck A and B at the same time.
At first, all the fluorescent indicator light up, then the system returns to normal display. (However, “0.00” is not displayed on the counter.)
2. To release the test mode, turn OFF the power switch.

Record/Playback Head Azimuth Adjustment

DECK A DECK B

Procedure:

1. Forward Playback Mode

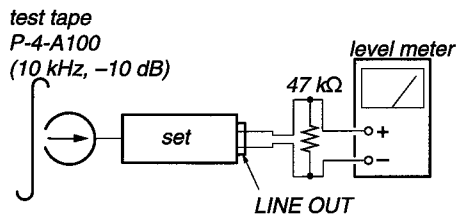

2. Turn the adjustment screw for the maximum output levels. If these levels do not match, turn the adjustment screw until both of output levels match together within 1 dB.

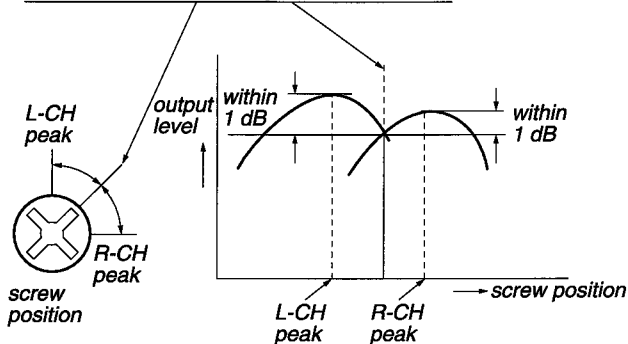

3. Playback Mode

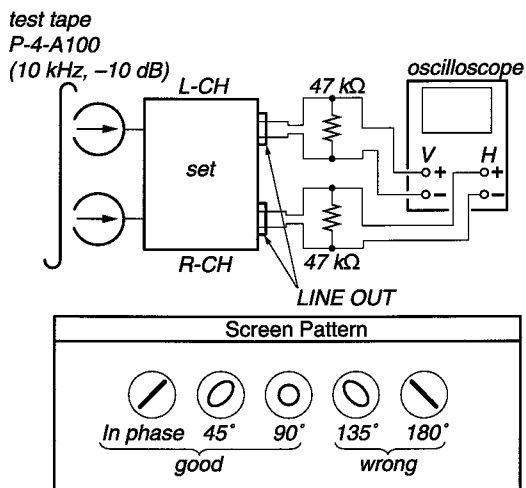

4. Change the reverse playback mode and repeat the steps 1 to 3.
5. After the adjustment, lock the adjustment screws with suitable locking compound.

Adjustment Location: –record/playback head–

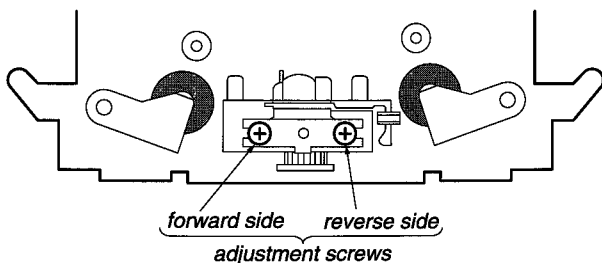

Tape Speed Adjustment

DECK A DECK B

Procedure:

–Forward Playback Mode–

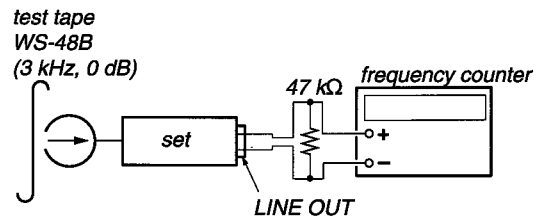

(High speed adjustment)

1. Set to test mode. (Refer to page 8.)
2. Set to FWD playback mode.
3. Twice pressing the HIGH/NORMAL switch.
4. Adjust RV72 so that the frequency counter reading becomes $6,000 \pm 20$ Hz.
5. Release test mode after adjustment is completed.

(Normal speed adjustment)

1. Set to FWD playback mode.
2. Adjust RV71 so that the frequency counter reading becomes $3,000 \pm 10$ Hz.

(Pitch control adjustment) (TC-WE725/WE825S only)

1. Push the PITCH CONTROL switch.
2. Set RV902 to mechanical center.
3. Set to FWD playback mode.
4. Adjust RV601 so that the frequency counter reading becomes $3,000 \pm 10$ Hz.

Frequency difference between the beginning and the end of the tape should be within $\pm 3\%$.

Frequency difference between the deck A and deck B the beginning of the tape should be within $\pm 1.5\%$.

Adjustment Location: AUDIO board, MAIN board
(See page 11.)

Playback Level Adjustment

DECK A DECK B

Procedure:

–Forward Playback Mode–

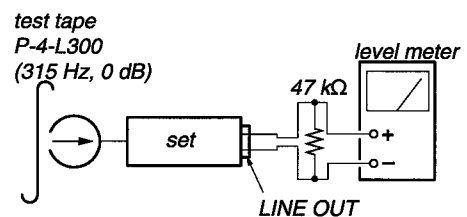

Adjust RV11 (L-CH) and RV21 (R-CH) so the level meter reading becomes the adjustment limits below.

Adjustment Value:

LINE OUT level : -7.7 ± 0.5 dB (0.301 to 0.338 V)

Level difference between channels : within 0.5 dB

Confirm that the LINE OUT level does not change in playback mode while changing the mode from playback to stop several times.

Adjustment Location: AUDIO board (See page 11.)

Bias Consumption Current Adjustment

DECK A DECK B

This adjustment should be performed when replacing the head assy or the bias oscillator transformer (T81, T91).

Procedure:

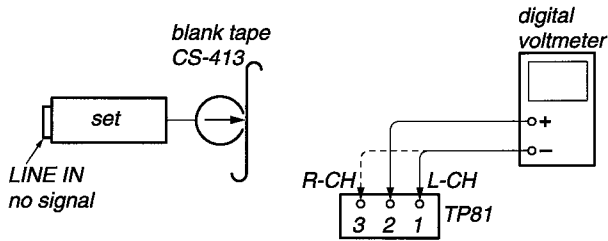

1. Connect the digital voltmeter to test point TP81.
2. Set RV81 (L-CH), RV91 (R-CH) to mechanical center.
3. Set to FWD record mode.
4. Adjust T81 (L-CH), T91 (R-CH) so that the digital voltmeter reading becomes minimum.

Adjustment Value: Maximum 220 mV

Adjustment Location: AUDIO board (See page 11.)

Record Bias Adjustment

DECK A DECK B

Setting:

REC LEVEL control : standard record position (See page 8.)

Procedure:

1. Record Mode

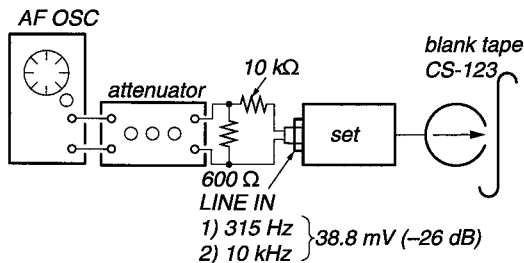

2. Playback Mode

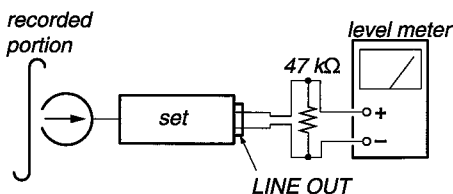

Confirm that the 10 kHz playback output is 0 ± 0.5 dB relative to the 315 Hz output. If necessary, adjust RV81 (L-CH), RV91 (R-CH) and repeat the steps given above.

Adjustment Location: AUDIO board (See page 11.)

Record Level Adjustment

DECK A DECK B

Setting:

REC LEVEL control : standard record position (See page 8.)

Procedure:

1. Record Mode

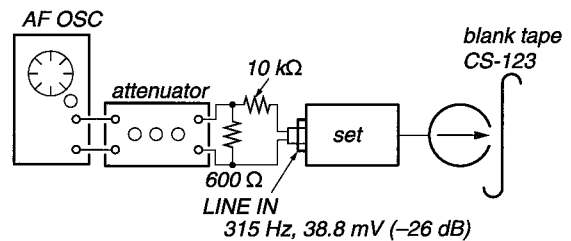

2. Playback Mode

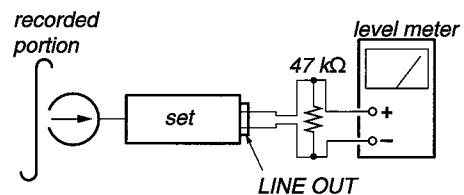

Confirm playback the tape recorded become adjustment level as follows.

If necessary, adjust Deck A : RV102 (L-CH), RV202 (R-CH) and Deck B : RV101 (L-CH), RV201 (R-CH) and repeat the steps 1 and 2.

Adjustment Value:

LINE OUT level : -26 ± 0.5 dB (36.7 to 41.1 mV)

Adjustment Location: MAIN board (See page 11.)

Adjustment Location:

—audio board (component side)—

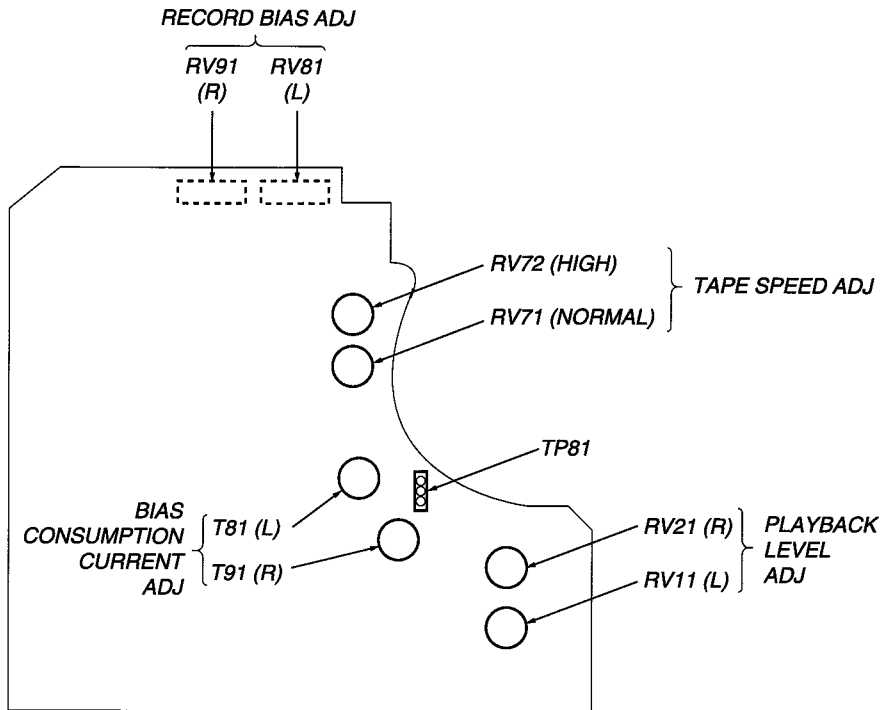

—main board (component side)—

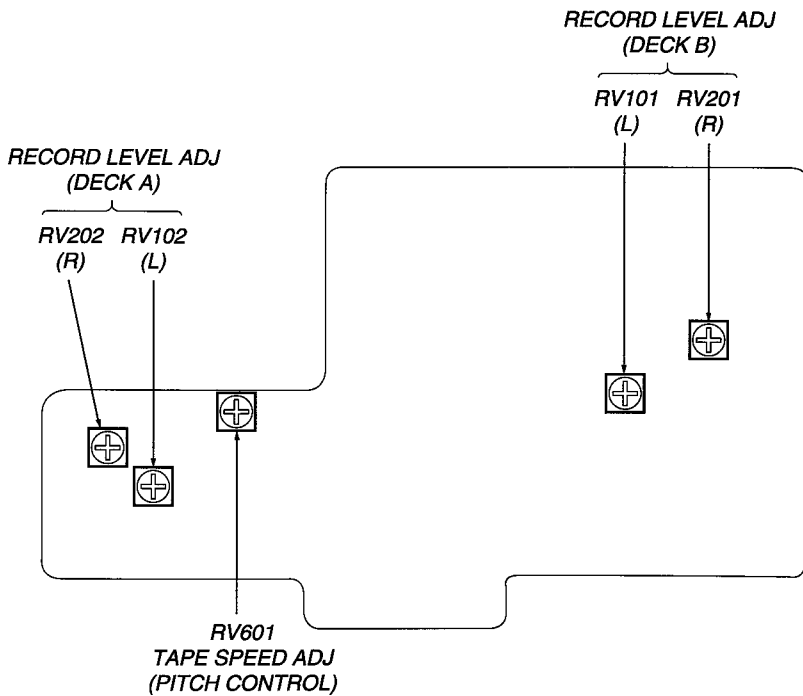

SECTION 5 DIAGRAMS

5-1. IC PIN DESCRIPTION

• IC801 CXP82432A-006Q (SYSTEM CONTROLLER)

Pin No.	Pin Name	I/O	Pin Description
1	T-REEL (A)	I	Take-up reel rotation detection input (DECK A)
2	S-REEL (B)	I	Supply reel rotation detection input (DECK B)
3	T-REEL (B)	I	Take-up reel rotation detection input (DECK B)
4	SIRCS IN	I	Sircs signal input
5	POWER IN	I	Power-off detection input
6	VOL OUT	O	Record level control output (PWM)
7	A/B SEL	I	Playback A/B selector input "L" : A, "H" : B
8	CONTROL-A IN	I	Control A signal input
9	CONTRL-A OUT	O	Control A signal output
10	REC MUTE (A)	O	Recording mute output (DECK A) "L" : Mute ON
11	REC CAL 0 (A)	O	Recording CAL-0 output for auto calibration. (DECK A)
12	REC CAL 1 (A)	O	Recording CAL-1 output for auto calibration. (DECK A)
13	GP CAL 0 (A)	O	GEQ CAL-0 output for auto calibration. (DECK A)
14	GP CAL 1 (A)	O	GEQ CAL-1 output for auto calibration. (DECK A)
15	REC/PB	O	Record/playback dolby NR mode selector output "L" : Playback
16	REC MUTE (B)	O	Recording mute output (DECK B) "L" : Mute ON
17	AMS IN	I	AMS signal input "L" : Music present
18	CAL/OFF/S	O	Audio selector "H" : CAL, "Open" : Dolby off, "L" : Dolby S
19	C/B/OFF	O	Dolby selector "H" : C, "Open" : B, "L" : Dolby off
20	REC CAL 0 (B)	O	Recording CAL-0 output for auto calibration. (DECK B)
21	REC CAL 1 (B)	O	Recording CAL-1 output for auto calibration. (DECK B)
22	GP CAL 0 (B)	O	GEQ CAL-0 output for auto calibration. (DECK B)
23	GP CAL 1 (B)	O	GEQ CAL-1 output for auto calibration. (DECK B)
24	POWER OUT	O	Power hold output
25	RECEQ HIGH/NORM	O	REC EQ high/normal select output "L" : Normal
26	PASS/MUTE/DOLBY	O	Audio selector "H" : Pass, "Open" : Mute, "L" : Dolby
27	BS/AMS/OFF	O	AMS amp selector "H" : BS, "Open" : AMS, "L" : OFF
28	EX IN 0	I	Expander control input (0)
29	EX IN 1	I	Expander control input (1)
30	EXP CTRL 0	O	Expander control output (0)
31	EXP CTRL 1	O	Expander control output (1)
32	A/D IN 0	I	Expander A/D input (0)
33	A/D IN 1	I	Expander A/D input (1)
34	KEY 5	I	Key 5 input (A/D converter)
35	VOL IN	I	Record volume input (A/D converter)
36	TEST/PITCH/VER	I	Test mode/pitch control/version input
37	CD SYNC LED	O	CD SYNCHRO LED driver "L" : ON
38	RESET	I	System reset input
39	EXTAL	I	System clock oscillator input (10 MHz)
40	XTAL	O	System clock oscillator output (10 MHz)
41	VSS	—	Ground
42	TX	—	Connected to ground.
43	TEX	—	Connected to ground.
44	ARL LED	O	ARL LED driver "H" : ON
45	PITCH ON/OFF	O	Pitch control ON/OFF output "L" : ON
46	AVREF	I	Reference voltage input for A/D converter.
47	AVSS	—	Ground for A/D converter.
48	LINE MUTE	O	Line mute ON/OFF control output "L" : Mute ON
49	OSC H/L	O	OSC frequency H/L select output for auto calibration.
50	OSC ON/OFF	O	OSC ON/OFF select output for auto calibration.
51	BIAS CAL 0 (B)	O	EQ bias CAL-0 output for auto calibration. (DECK B)

Pin No.	Pin Name	I/O	Pin Description
52	BIAS CAL 1 (B)	O	EQ bias CAL-1 output for auto calibration. (DECK B)
53	BIAS CAL 2 (B)	O	EQ bias CAL-2 output for auto calibration. (DECK B)
54	BIAS CAL 3 (B)	O	EQ bias CAL-3 output for auto calibration. (DECK B)
55	BIAS CAL 0 (A)	O	EQ bias CAL-0 output for auto calibration. (DECK A)
56	BIAS CAL 1 (A)	O	EQ bias CAL-1 output for auto calibration. (DECK A)
57	BIAS CAL 2 (A)	O	EQ bias CAL-2 output for auto calibration. (DECK A)
58	BIAS CAL 3 (A)	O	EQ bias CAL-3 output for auto calibration. (DECK A)
59	CAP.M (B)	O	Capstan motor driver output (DECK B) "H" : ON
60	CAP.M (A)	O	Capstan motor driver output (DECK A) "H" : ON
61	CAP.M H/L	O	Capstan motor high/normal select output "L" : ON
62 – 77	P16 – P1	O	Fluorescent indicator tube segment driver
78 – 85	G1 – G8	O	Fluorescent indicator tube grid driver
86	G6,G7	O	Fluorescent indicator tube grid driver
87	G7,G8	O	Fluorescent indicator tube grid driver
88	VFDP	—	Fluorescent indicator tube power supply (-28 V)
89	VDD	—	Power supply (+5 V)
90	N.C	—	Connected to power supply.
91	VSS	—	Ground
92	REEL (A) +	O	Reel motor (+) output (DECK A)
93	REEL (A) -	O	Reel motor (-) output (DECK A)
94	REEL (B) +	O	Reel motor (+) output (DECK B)
95	REEL (B) -	O	Reel motor (-) output (DECK B)
96	BIAS (A)	O	Bias ON/OFF output (DECK A) "H":ON
97	RELAY (A)	O	Relay record/playback selector output (DECK A) "L" : Record
98	BIAS (B)	O	Bias ON/OFF output (DECK B) "H" : ON
99	RELAY (B)	O	Relay record/playback selector output (DECK B) "L" : Record
100	S-REEL (A)	I	Supply reel rotation detection input (DECK A)

5-2. CIRCUIT BOARDS LOCATION

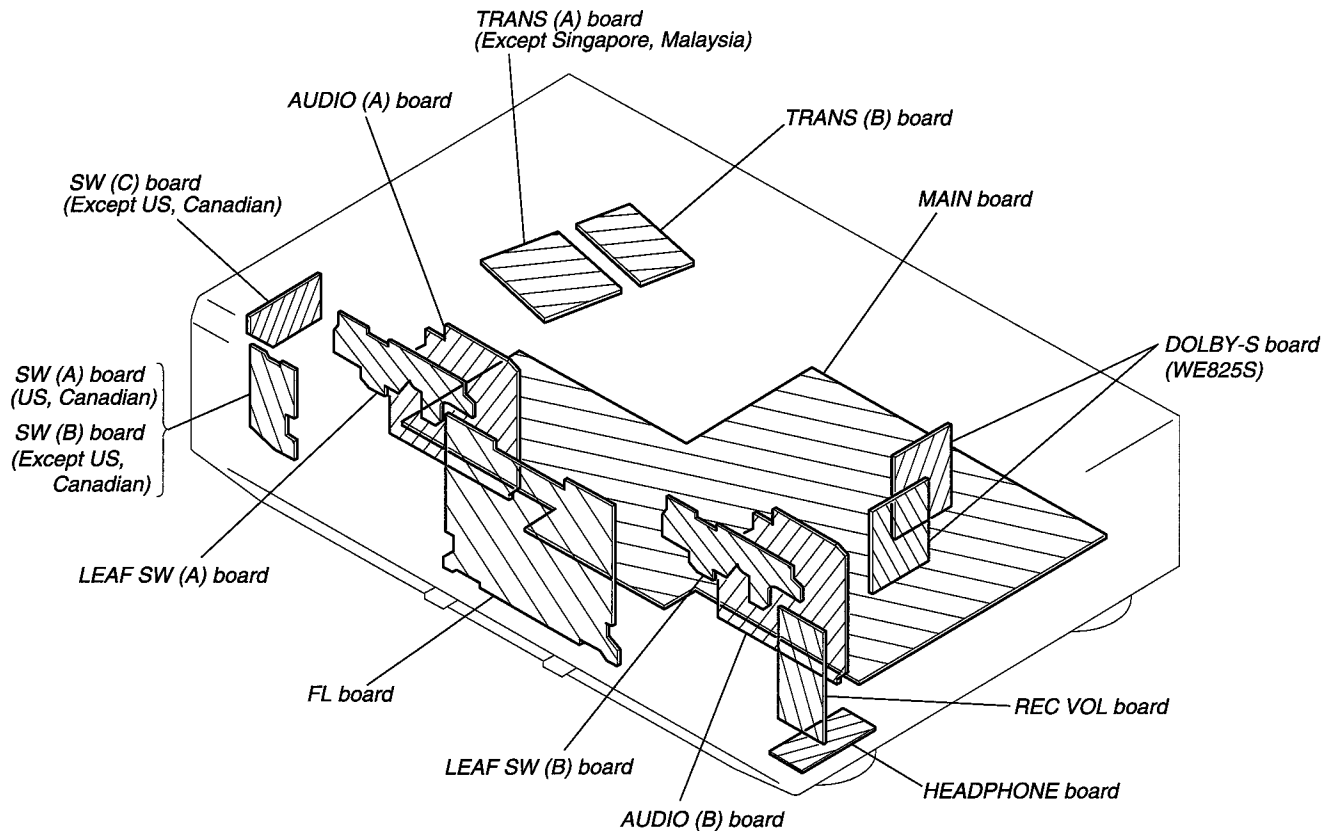

THIS NOTE IS COMMON FOR PRINTED WIRING BOARDS AND SCHEMATIC DIAGRAMS.

(In addition to this, the necessary note is printed in each block.)

• For printed wiring boards.

- : parts extracted from the component side.
- : Through hole.
- : Pattern from the side which enables seeing. (The other layers' patterns are not indicated.)

: Chip transistor of abbreviation (E, C, B)

• For schematic diagrams.

- All capacitors are in μF unless otherwise noted. pF: μF 50 WV or less are not indicated except for electrolytics and tantalums.
- All resistors are in Ω and $1/4\text{ W}$ or less unless otherwise specified.
- % : indicates tolerance.
- Δ : internal component.
- : fusible resistor.
- : panel designation.

Note:

The components identified by mark Δ or dotted line with mark Δ are critical for safety. Replace only with part number specified.

Note:

Les composants identifiés par une marque Δ sont critiques pour la sécurité. Ne les remplacer que par une pièce portant le numéro spécifié.

- : B+ Line.
- : B- Line.
- : adjustment for repair.
- Voltage is dc with respect to ground under no-signal (detuned) condition.

no mark : PB (DECK A)

() : REC (DECK A)

< > : PB (DECK B)

[] : REC (DECK B)

<< >> : STOP

* : impossible to measure

- Voltages are taken with a VOM (Input impedance $10\text{ M}\Omega$). Voltage variations may be noted due to normal production tolerances.

• Signal path.

: PB (DECK A)

: REC (DECK A)

: PB (DECK B)

: REC (DECK B)

• Abbreviation

CND : Canadian model.

AUS : Australian model.

SP : Singapore model.

MY : Malaysia model.

CH : Chinese model.

SECTION 6 EXPLODED VIEWS

NOTE:

- The mechanical parts with no reference number in the exploded views are not supplied.
- Items marked "*" are not stocked since they are seldom required for routine service. Some delay should be anticipated when ordering these items.
- Abbreviation
 CND : Canadian model
 AUS : Australian model
 SP : Singapore model
 MY : Malaysia model
 CH : Chinese model

- -XX and -X mean standardized parts, so they may have some difference from the original one.
- Color Indication of Appearance Parts
 Example :
 KNOB, BALANCE (WHITE) ... (RED)
 ↑ ↑
 Parts Color Cabinet's Color
- Accessories and packing materials and hardware (# mark) list are given in the last of this parts list.

The components identified by mark Δ or dotted line with mark Δ are critical for safety. Replace only with part number specified.

Les composants identifiés par une marque Δ sont critiques pour la sécurité. Ne les remplacer que par une pièce portant le numéro spécifié.

6-1. CASE SECTION

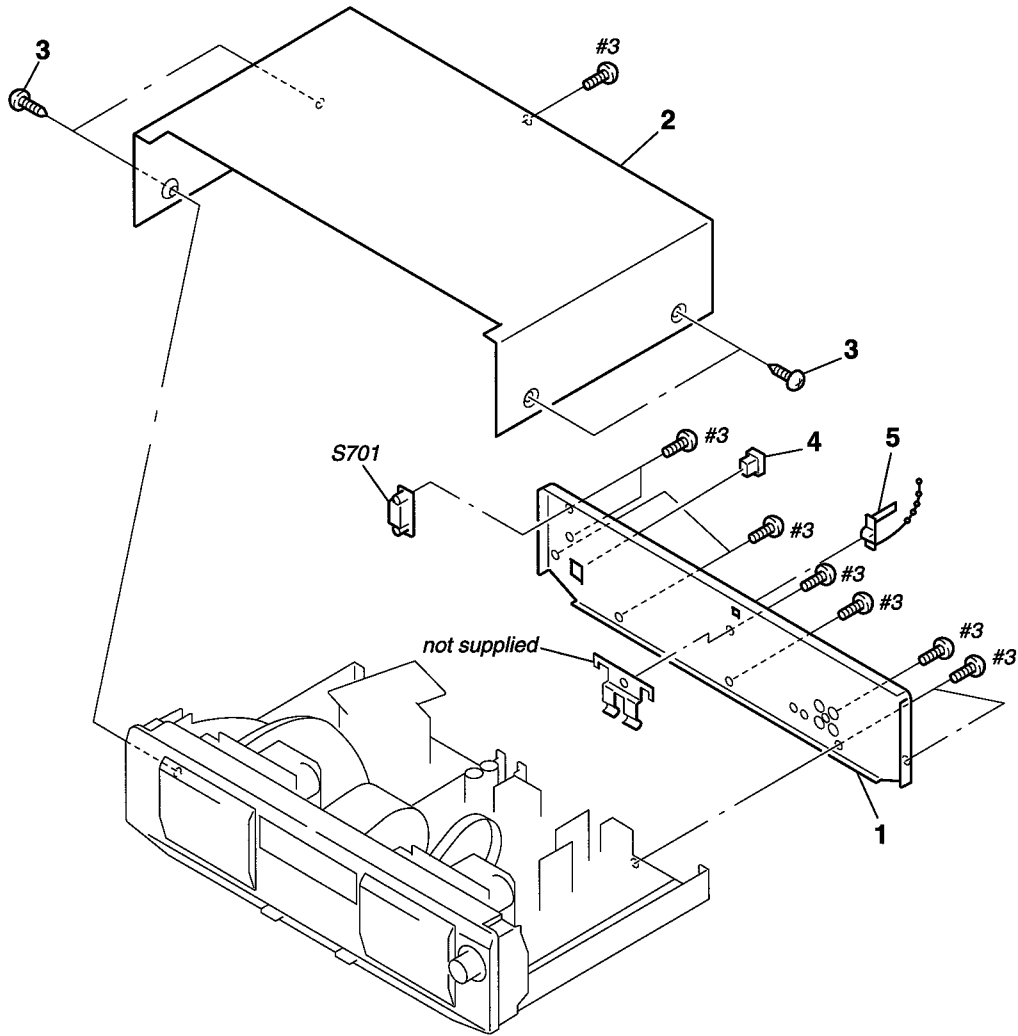

Ref. No.	Part No.	Description	Remark	Ref. No.	Part No.	Description	Remark
* 1	3-021-228-01	PANEL, BACK (WE625:US)		* 2	3-935-634-01	CASE (410726)	
* 1	3-021-228-11	PANEL, BACK (WE625:CND)		3	3-363-099-01	SCREW (CASE 3 TP2)	
* 1	3-021-228-21	PANEL, BACK (WE625:AUS)		4	3-703-244-00	BUSHING (2104), CORD (EXCEPT US,CND)	
* 1	3-021-228-31	PANEL, BACK (WE625:SP,MY)		* 4	3-703-571-11	BUSHING (S) (4516), CORD (US,CND)	
* 1	3-021-228-41	PANEL, BACK (WE625:CH)		5	4-956-370-12	BAND, PLUG FIXED (UK,AUS)	
* 1	3-021-242-01	PANEL, BACK (WE725:AEP)		Δ S701	1-692-155-11	SELECTOR, POWER VOLTAGE (VOLTAGE)	(SP,MY)
* 1	3-021-242-11	PANEL, BACK (WE725:UK)					
* 1	3-021-243-01	PANEL, BACK (WE825S:AEP)					
* 1	3-021-243-11	PANEL, BACK (WE825S:UK)					
* 1	3-021-243-32	PANEL, BACK (WE825S:US)					

6-2. CHASSIS SECTION

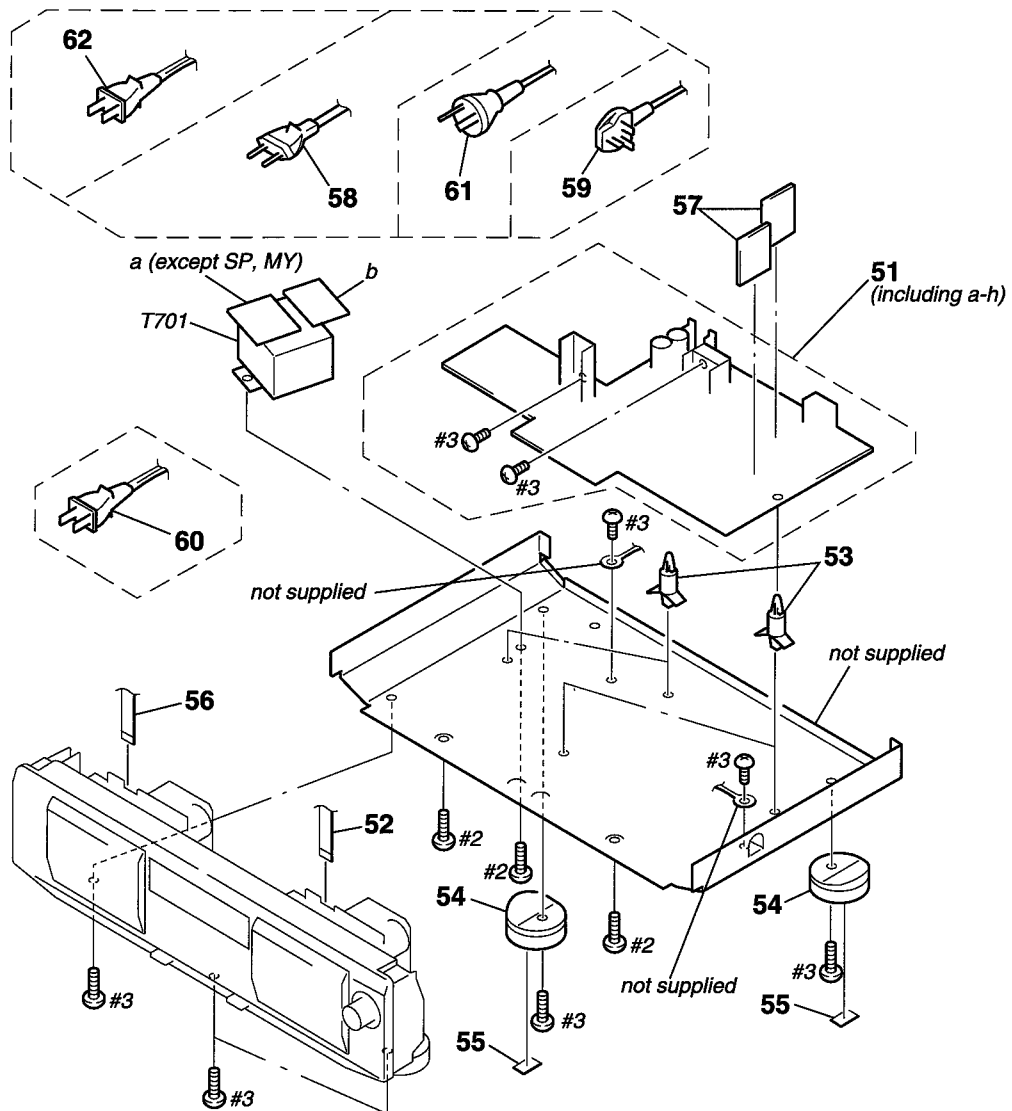

<p>The components identified by mark Δ or dotted line with mark Δ are critical for safety. Replace only with part number specified.</p>	<p>Les composants identifiés par une marque Δ sont critiques pour la sécurité. Ne les remplacer que par une pièce portant le numéro spécifié.</p>
---	---

Ref. No.	Part No.	Description	Remark	Ref. No.	Part No.	Description	Remark
* 51	A-2007-758-A	MAIN BOARD, COMPLETE (WE725)		* 55	4-978-398-21	CUSHION	
* 51	A-2007-761-A	MAIN BOARD, COMPLETE (WE625:US,CND)		56	1-769-883-11	WIRE (FLAT TYPE) (7 CORE) (WE625)	
* 51	A-2007-762-A	MAIN BOARD, COMPLETE (WE625:AUS)		56	1-769-916-11	WIRE (FLAT TYPE) (9 CORE) (WE725/WE825S)	
* 51	A-2007-763-A	MAIN BOARD, COMPLETE (WE625:SP,MY)		* 57	A-2007-801-A	DOLBY-S BOARD, COMPLETE (WE825S)	
* 51	A-2007-764-A	MAIN BOARD, COMPLETE (WE625:CH)		Δ 58	1-575-651-21	CORD, POWER (AEP,SP,MY)	
* 51	A-2007-765-A	MAIN BOARD, COMPLETE (WE825S:AEP,UK)		Δ 59	1-751-529-11	CORD, POWER (UK)	
* 51	A-2007-802-A	MAIN BOARD, COMPLETE (WE825S:US)		Δ 60	1-590-926-11	CORD, POWER (US,CND)	
52	1-590-486-11	WIRE (FLAT TYPE) (7 CORE) (WE625)		Δ 61	1-696-845-11	CORD, POWER (AUS)	
52	1-769-914-11	WIRE (FLAT TYPE) (9 CORE) (WE725/WE825S)		Δ 62	1-782-510-11	CORD, POWER (CH)	
* 53	3-346-265-31	HOLDER, PC BOARD		Δ T701	1-431-786-11	TRANSFORMER, POWER (AEP,UK,CH,AUS)	
54	4-977-591-01	FOOT (F50150S) (EXCEPT US,CND)		Δ T701	1-431-788-11	TRANSFORMER, POWER (US,CND)	
54	4-977-591-11	FOOT (F50150S) (US,CND)		Δ T701	1-431-789-11	TRANSFORMER, POWER (SP,MY)	

6-3. CASSETTE HOLDER SECTION

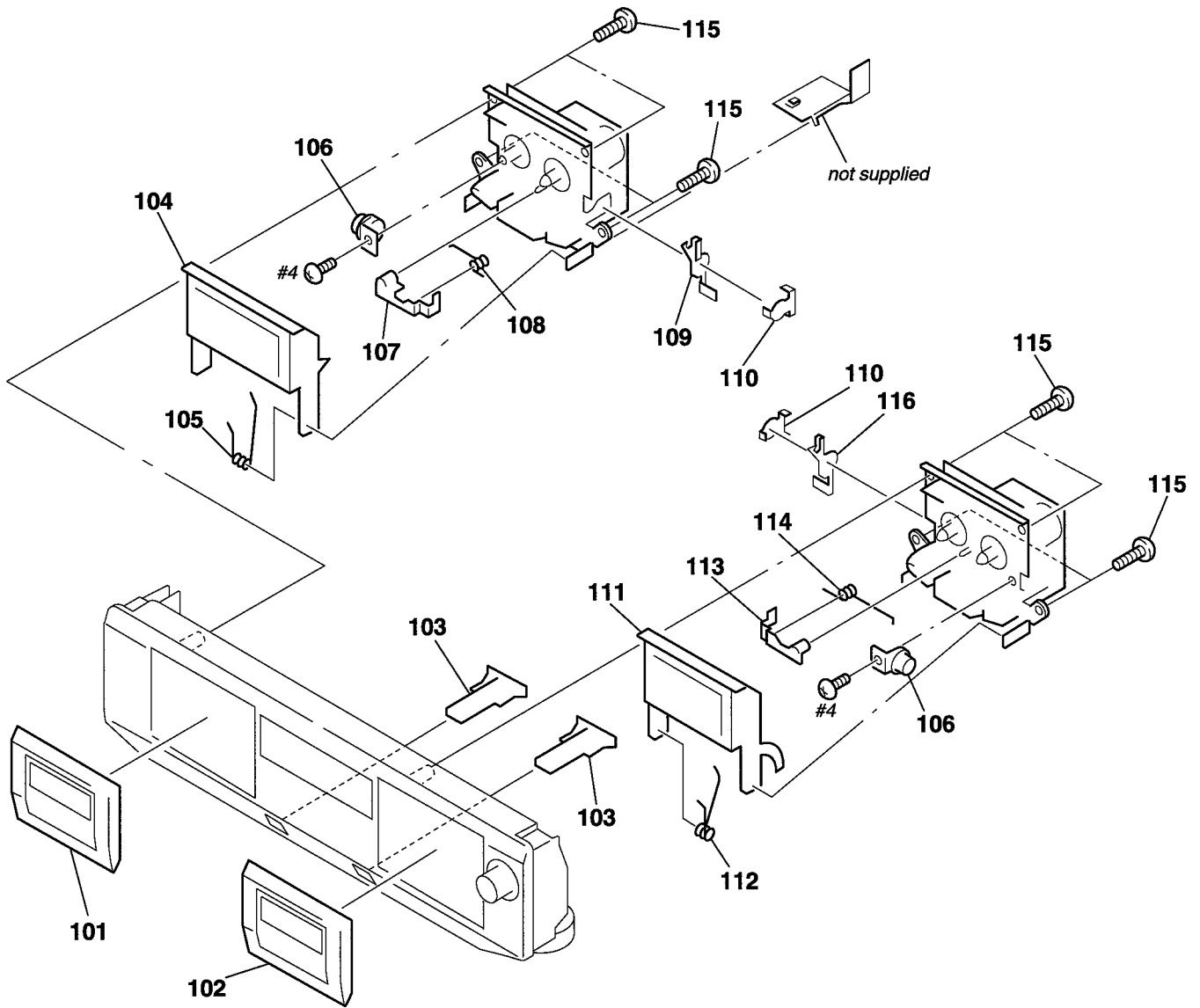

Ref. No.	Part No.	Description	Remark	Ref. No.	Part No.	Description	Remark
101	X-3374-864-1	LID (A) ASSY, CASSETTE		* 109	3-354-953-01	LEVER (LOCK LEVER L)	
102	X-3374-865-1	LID (B) ASSY, CASSETTE		110	3-354-957-01	JOINT (LOCK LEVER)	
103	3-931-427-31	BUTTON (EJ)		111	X-4945-946-1	HOLDER (R) ASSY, CASSETTE	
104	X-4945-947-1	HOLDER (L) ASSY, CASSETTE		112	4-959-232-21	SPRING (R), TORSION	
105	4-959-231-21	SPRING (L), TORSION		113	3-354-956-01	LEVER (EJ SAFETY LEVER R)	
106	3-354-963-01	DAMPER		114	3-354-962-11	SPRING (EJ SAFETY SPRING R)	
107	3-354-955-01	LEVER (EJ SAFETY LEVER L)		115	4-951-620-01	SCREW (2.6X8), +BVTP	
108	3-354-961-11	SPRING (EJ SAFETY SPRING L)		* 116	3-354-954-01	LEVER (LOCK LEVER R)	

6-4. FRONT PANEL SECTION

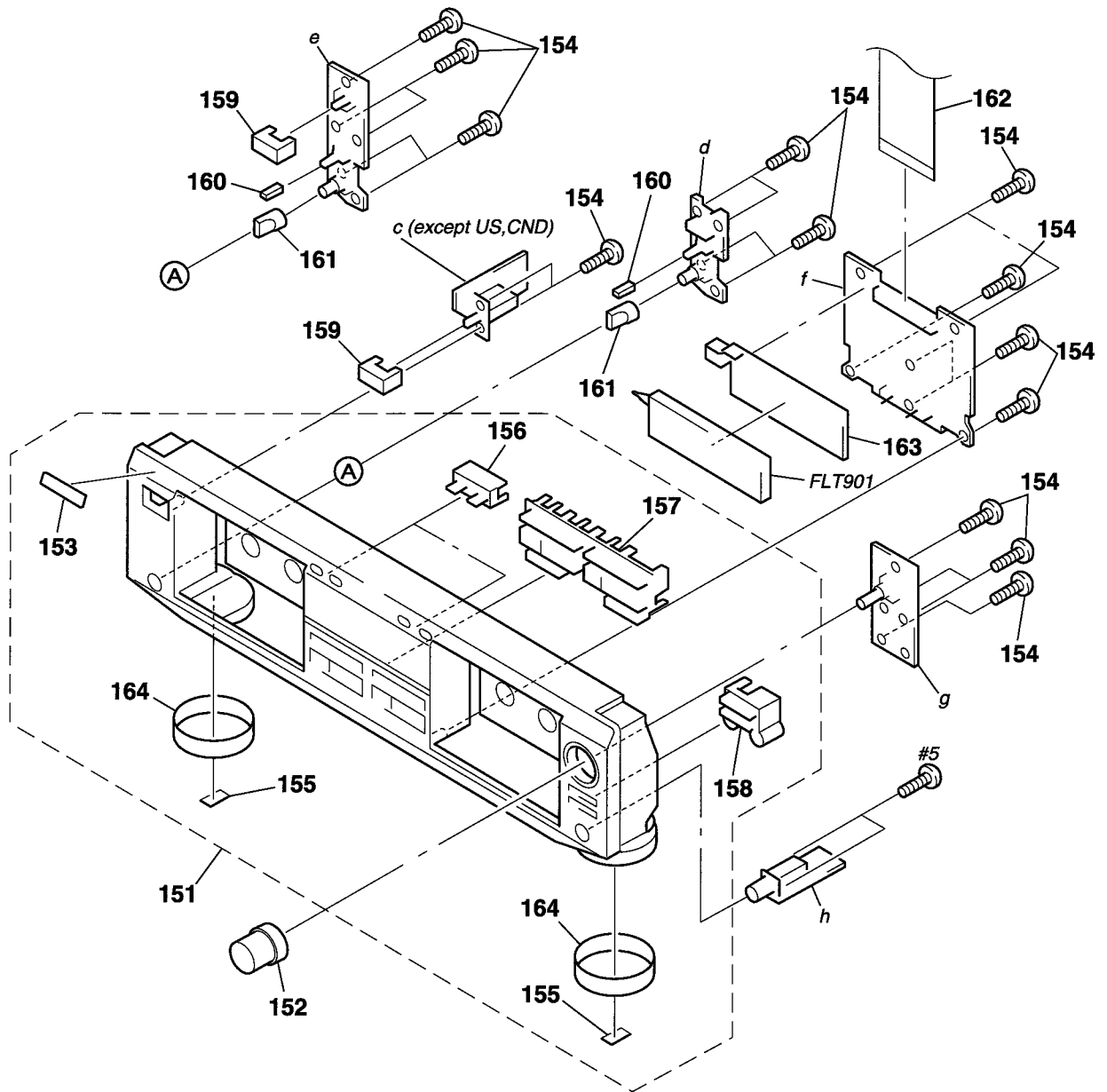

Ref. No.	Part No.	Description	Remark	Ref. No.	Part No.	Description	Remark
151	X-3374-855-1	PANEL ASSY, FRONT (WE625:US,CND)		158	X-3371-370-1	BUTTON (SYNCHRO) ASSY	
151	X-3374-857-1	PANEL ASSY, FRONT (WE725)		159	3-931-429-41	BUTTON (POWER) (EXCEPT US,CND)	
151	X-3374-858-1	PANEL ASSY, FRONT (WE825S:AEP,UK)		159	3-931-429-51	BUTTON (POWER) (US,CND)	
151	X-3374-942-1	PANEL ASSY, FRONT (WE625:CH,SP,MY,AUS)		160	3-380-952-21	BUTTON (WE725/WE825S)	
151	X-3375-510-1	PANEL ASSY, FRONT (WE825S:US)		161	3-931-378-01	KNOB (F10) (WE725/WE825S)	
152	3-021-239-01	KNOB (REC)		162	1-769-598-11	WIRE (FLAT TYPE) (41 CORE)	
153	4-996-698-41	EMBLEM, SONY		* 163	3-377-337-11	HOLDER (FL)	
154	4-951-620-01	SCREW (2.6X8), +BVTP		164	4-977-593-01	RING (DIA. 50), ORNAMENTAL	(EXCEPT US,CND)
* 155	4-978-398-21	CUSHION		FLT901	1-517-263-11	INDICATOR TUBE, FLUORESCENT	
156	3-021-232-01	BUTTON (COUNTER)					
157	3-021-230-01	BUTTON (FUNCTION)					

6-5. TAPE MECHANISM SECTION 1

	DECK A	DECK B
WE625	TCM-190RB12CL	TCM-190RB12CL
WE725	TCM-190RB13C	TCM-190RB11C
WE825S	TCM-190RB13C	TCM-190RB11C

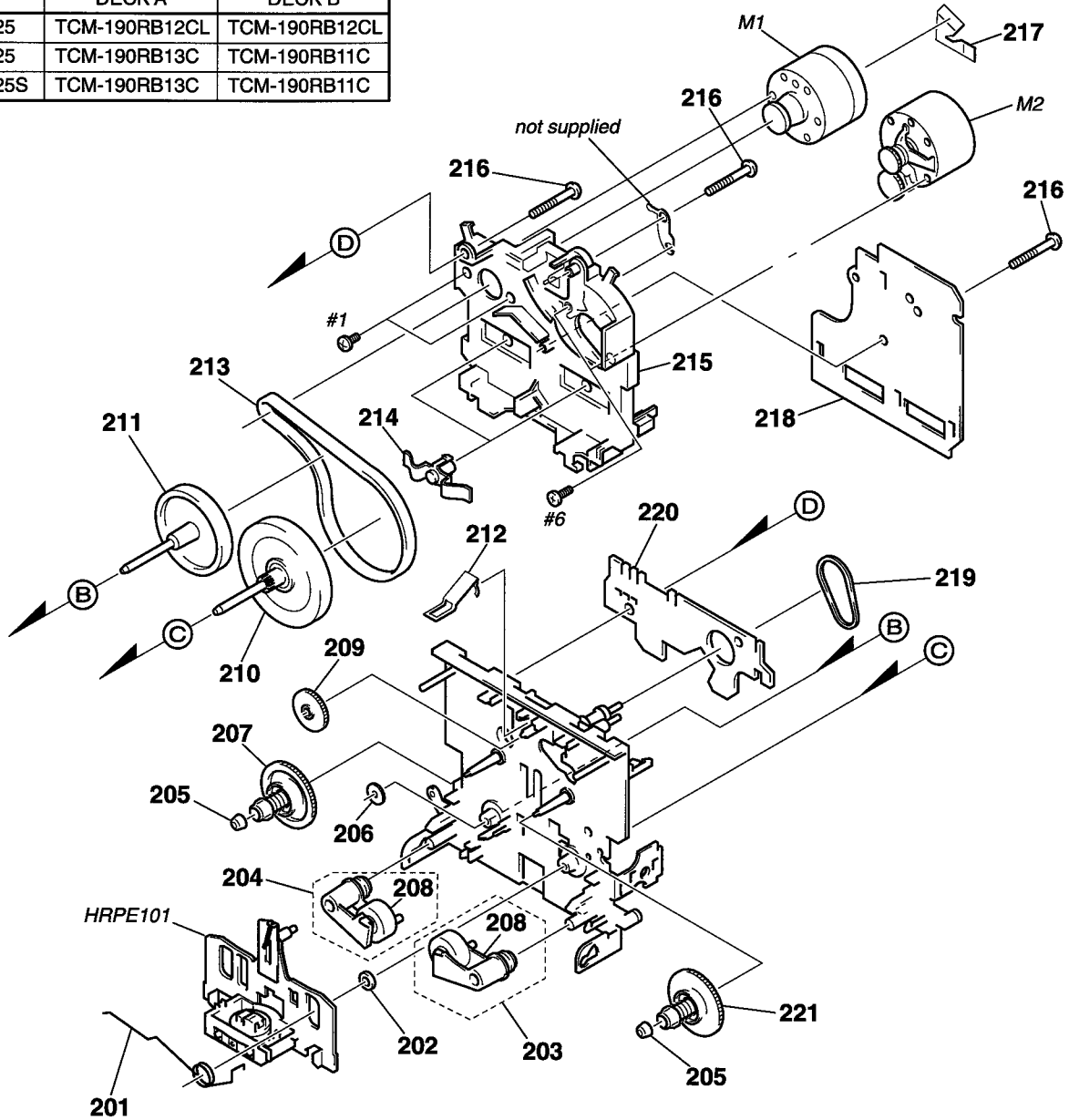

Ref. No.	Part No.	Description	Remark	Ref. No.	Part No.	Description	Remark
201	3-907-362-01	SPRING, TORSION		216	3-359-414-01	SCREW (+PTPWH 2X23)	
202	3-356-713-01	WASHER		217	1-638-983-11	MOTOR FLEXIBLE BOARD	
203	X-3366-047-1	LEVER (PINCH F) ASSY		* 218	A-2007-040-A	AUDIO (A) BOARD, COMPLETE (WE625)	
204	X-3366-048-1	LEVER (PINCH R) ASSY		* 218	A-2007-509-A	AUDIO (A) BOARD, COMPLETE (WE725/WE825S)	
205	3-362-308-01	CAP (REEL)		* 218	A-2007-040-A	AUDIO (B) BOARD, COMPLETE	
206	3-356-714-01	WASHER		219	3-359-466-01	BELT (FR), SQUARE	
207	X-3366-971-1	TABLE ASSY (B), REEL		* 220	1-634-841-14	LEAF SW (A) BOARD (DECK A) (WE725/WE825S)	
208	3-355-808-02	PINCH ROLLER		* 220	1-638-020-11	LEAF SW (A) BOARD (DECK A) (WE625)	
209	3-359-424-01	GEAR (REV GEAR)		* 220	1-634-841-14	LEAF SW (B) BOARD (DECK B) (WE725/WE825S)	
210	X-3367-629-1	FLYWHEEL (FWD) ASSY		* 220	1-638-020-11	LEAF SW (B) BOARD (DECK B) (WE625)	
211	X-3367-630-1	FLYWHEEL (REV) ASSY		221	X-3366-970-1	TABLE ASSY, REEL (WE625)	
212	3-359-430-01	SPRING (CASSETTE RETAINER), LEAF		221	X-3366-971-1	TABLE ASSY (B), REEL (WE725/WE825S)	
213	3-359-417-01	BELT (FLAT), CAPSTAN		HRPE101	A-2004-527-A	DECK ASSY, HEAD (RECORD/PLAYBACK/ERASE)	
214	3-575-321-00	RETAINER, THRUST, CAPSTAN		M1	X-3365-377-2	MOTOR ASSY (CAPSTAN)	
215	3-359-436-11	BASE (THRUST RETAINER), FITTING		M2	X-3363-501-2	MOTOR ASSY (REEL)	

6-6. TAPE MECHANISM SECTION 2

	DECK A	DECK B
WE625	TCM-190RB12CL	TCM-190RB12CL
WE725	TCM-190RB13C	TCM-190RB11C
WE825S	TCM-190RB13C	TCM-190RB11C

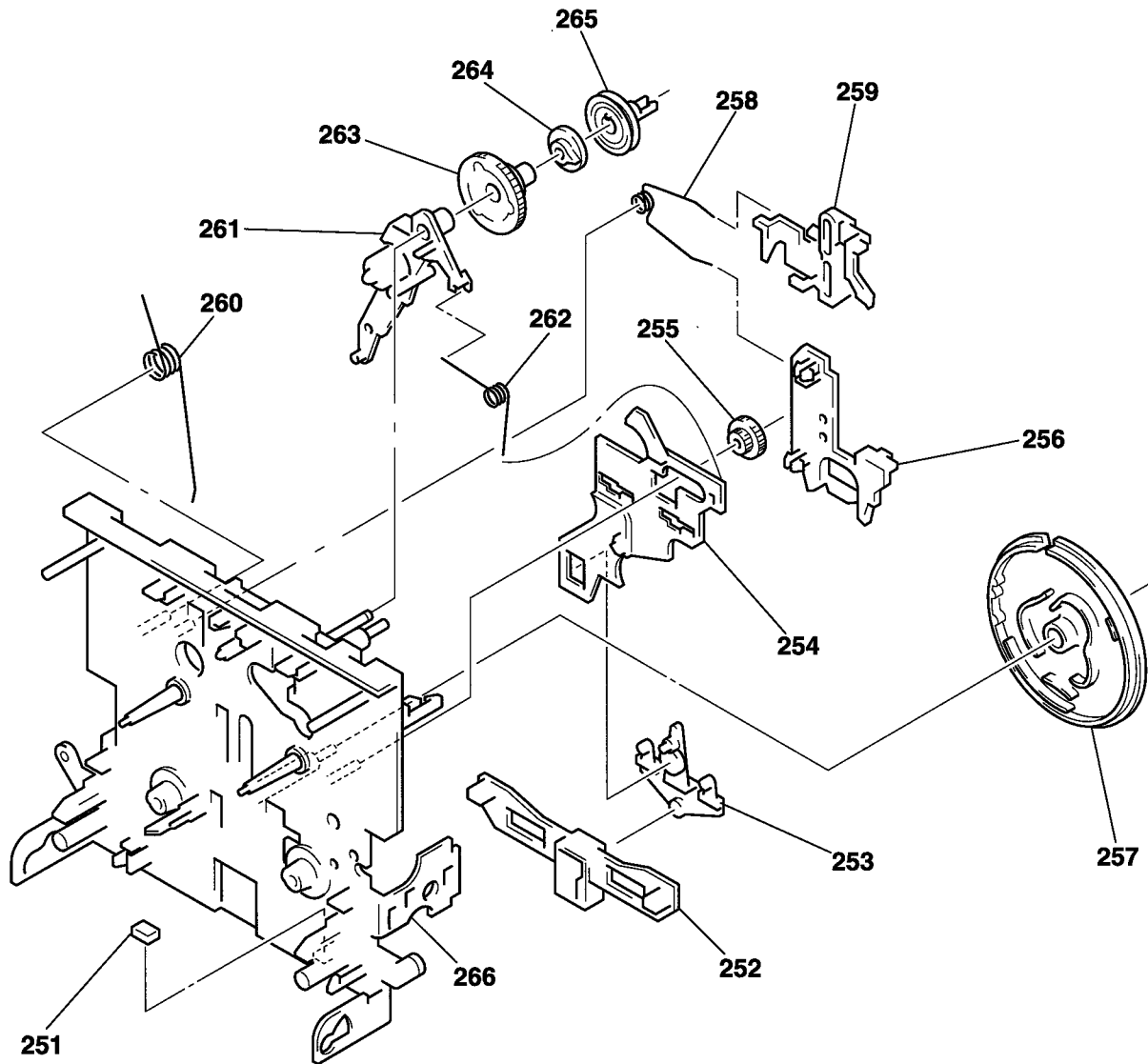

Ref. No.	Part No.	Description	Remark	Ref. No.	Part No.	Description	Remark
251	3-359-469-01	SPACER		259	3-359-429-01	SLIDER (BRAKE PLATE)	
252	3-359-425-01	SLIDER (REVERSE SLIDER)		260	3-359-456-01	SPRING (TRIGGER SPRING), TORSION	
253	3-359-426-01	LEVER (REVERSE LEVER)		261	X-3366-569-1	ARM ASSY, FR	
* 254	3-359-415-01	SLIDER (TRIGGER SLIDER)		262	3-924-185-11	SPRING (FR ARM), TORSION	
255	3-359-448-01	GEAR (TRIGGER)		263	3-359-419-11	GEAR (FR GEAR)	
256	3-359-427-01	SLIDER (REVERSE SLIDER)		264	3-359-421-01	CLUTCH (REEL DISC)	
257	3-936-483-01	GEAR (CAM GEAR)		265	3-359-418-01	PULLEY (FR PULLEY)	
258	3-359-454-01	SPRING, TORSION		266	X-3359-415-1	CHASSIS ASSY, MECHANICAL	

AUDIO (A)

SECTION 7 ELECTRICAL PARTS LIST

NOTE:

- Due to standardization, replacements in the parts list may be different from the parts specified in the diagrams or the components used on the set.
- -XX and -X mean standardized parts, so they may have some difference from the original one.
- RESISTORS
All resistors are in ohms.
METAL: Metal-film resistor.
METAL OXIDE: Metal oxide-film resistor.
F: nonflammable
- Abbreviation
CND : Canadian model MY : Malaysia model
AUS : Australian model CH : Chinese model
SP : Singapore model

- Items marked "*" are not stocked since they are seldom required for routine service. Some delay should be anticipated when ordering these items.
- SEMICONDUCTORS
In each case, u : μ , for example:
uA.. : μ A.. uPA.. : μ PA..
uPB.. : μ PB.. uPC.. : μ PC.. uPD.. : μ PD..
- CAPACITORS
uF : μ F
- COILS
uH : μ H

The components identified by mark Δ or dotted line with mark. Δ are critical for safety. Replace only with part number specified.

Les composants identifiés par une marque Δ sont critiques pour la sécurité. Ne les remplacer que par une pièce portant le numéro spécifié.

When indicating parts by reference number, please include the board.

Ref. No.	Part No.	Description	Remark	Ref. No.	Part No.	Description	Remark
*	A-2007-040-A	AUDIO (A) BOARD, COMPLETE (WE625)				< CONNECTOR >	
*	A-2007-509-A	AUDIO (A) BOARD, COMPLETE (WE725/WE825S)					

		< CAPACITOR >					
C11	1-163-131-00	CERAMIC CHIP	390PF 5% 50V	* CNP31	1-580-782-11	CONNECTOR, BOARD TO BOARD 10P	
C12	1-136-157-00	FILM	0.022uF 5% 50V	* CNP32	1-580-781-11	PIN, CONNECTOR (PC BOARD) 7P	
C13	1-124-234-00	ELECT	22uF 20% 16V	* CNP33	1-580-782-11	CONNECTOR, BOARD TO BOARD 10P	
C18	1-163-251-11	CERAMIC CHIP	100PF 5% 50V	* CNP71	1-564-719-11	PIN, CONNECTOR (SMALL TYPE) 3P	
C21	1-163-131-00	CERAMIC CHIP	390PF 5% 50V	CNP72	1-764-902-11	CONNECTOR, FFC/FPC 4P	
C22	1-136-157-00	FILM	0.022uF 5% 50V	CNP73	1-564-718-11	PIN, CONNECTOR (SMALL TYPE) 2P	
C23	1-124-234-00	ELECT	22uF 20% 16V	CNP75	1-564-718-11	PIN, CONNECTOR (SMALL TYPE) 2P	(WE725/WE825S)
C28	1-163-251-11	CERAMIC CHIP	100PF 5% 50V			< DIODE >	
C31	1-124-234-00	ELECT	22uF 20% 16V	D31	8-719-404-46	DIODE MA110	
C32	1-124-234-00	ELECT	22uF 20% 16V			< IC >	
C33	1-124-234-00	ELECT	22uF 20% 16V	IC31	8-759-711-85	IC NJM4580E-D	
C51	1-164-161-11	CERAMIC CHIP	0.0022uF 10% 100V	IC81	8-759-106-56	IC uPC1297CA	
C52	1-164-161-11	CERAMIC CHIP	0.0022uF 10% 100V			< COIL >	
C53	1-163-019-00	CERAMIC CHIP	0.0068uF 10% 50V	L81	1-410-780-11	INDUCTOR 27mH	
C54	1-136-601-11	FILM	0.01uF 5% 630V	L91	1-410-780-11	INDUCTOR 27mH	
C56	1-164-505-11	CERAMIC CHIP	2.2uF 16V			< TRANSISTOR >	
C57	1-164-346-11	CERAMIC CHIP	1uF 16V	Q51	8-729-822-05	TRANSISTOR 2SD1622-ST-TD	
C71	1-164-346-11	CERAMIC CHIP	1uF 16V	Q52	8-729-822-05	TRANSISTOR 2SD1622-ST-TD	
C80	1-124-234-00	ELECT	22uF 20% 16V	Q53	8-729-822-05	TRANSISTOR 2SD1622-ST-TD	
C81	1-164-232-11	CERAMIC CHIP	0.01uF 50V	Q71	8-729-216-22	TRANSISTOR 2SA1162-G	
C82	1-136-157-00	FILM	0.022uF 5% 50V			< RESISTOR >	
C83	1-164-004-11	CERAMIC CHIP	0.1uF 25V	R11	1-216-099-00	METAL CHIP 120K 5% 1/10W	
C84	1-136-478-11	FILM	470PF 5% 630V	R12	1-216-025-00	RES,CHIP 100 5% 1/10W	
C85	1-136-433-11	FILM	100PF 5% 630V	R13	1-216-100-00	RES,CHIP 130K 5% 1/10W	
C86	1-163-143-00	CERAMIC CHIP	0.0012uF 5% 50V	R14	1-216-068-00	METAL CHIP 6.2K 5% 1/10W	
C87	1-136-273-00	FILM	75PF 5% 630V	R21	1-216-099-00	METAL CHIP 120K 5% 1/10W	
C88	1-163-003-11	CERAMIC CHIP	330PF 10% 50V	R22	1-216-025-00	RES,CHIP 100 5% 1/10W	
C89	1-124-234-00	ELECT	22uF 20% 16V	R23	1-216-100-00	RES,CHIP 130K 5% 1/10W	
C90	1-107-584-11	CERAMIC	4PF 0.25PF 500V	R24	1-216-068-00	METAL CHIP 6.2K 5% 1/10W	
C91	1-164-232-11	CERAMIC CHIP	0.01uF 50V	R31	1-216-033-00	METAL CHIP 220 5% 1/10W	
C92	1-136-157-00	FILM	0.022uF 5% 50V	R32	1-216-033-00	METAL CHIP 220 5% 1/10W	
C93	1-164-004-11	CERAMIC CHIP	0.1uF 25V	R33	1-216-065-00	RES,CHIP 4.7K 5% 1/10W	
C94	1-136-478-11	FILM	470PF 5% 630V	R51	1-216-097-00	RES,CHIP 100K 5% 1/10W	
C95	1-136-433-11	FILM	100PF 5% 630V	R52	1-216-097-00	RES,CHIP 100K 5% 1/10W	
C96	1-163-143-00	CERAMIC CHIP	0.0012uF 5% 50V	R53	1-216-073-00	METAL CHIP 10K 5% 1/10W	
C97	1-136-273-00	FILM	75PF 5% 630V	R54	1-216-309-00	METAL CHIP 5.6 5% 1/10W	
C98	1-163-003-11	CERAMIC CHIP	330PF 10% 50V				
C99	1-164-005-11	CERAMIC CHIP	0.47uF 25V				

AUDIO (A)	AUDIO (B)
------------------	------------------

Ref. No.	Part No.	Description				Remark	Ref. No.	Part No.	Description				Remark
R55	1-216-309-00	METAL CHIP	5.6	5%	1/10W	C51	1-164-161-11	CERAMIC CHIP	0.0022uF	10%	100V		
R57	1-216-298-00	METAL CHIP	2.2	5%	1/10W	C52	1-164-161-11	CERAMIC CHIP	0.0022uF	10%	100V		
R71	1-216-082-00	RES,CHIP	24K	5%	1/10W	C53	1-163-019-00	CERAMIC CHIP	0.0068uF	10%	50V		
R72	1-216-081-00	METAL CHIP	22K	5%	1/10W	C54	1-136-601-11	FILM	0.01uF	5%	630V		
R73	1-216-089-00	RES,CHIP	47K	5%	1/10W	C56	1-164-505-11	CERAMIC CHIP	2.2uF		16V		
R74	1-216-089-00	RES,CHIP	47K	5%	1/10W	C57	1-164-346-11	CERAMIC CHIP	1uF		16V		
R81	1-216-073-00	METAL CHIP	10K	5%	1/10W	C71	1-164-346-11	CERAMIC CHIP	1uF		16V		
R82	1-216-085-00	METAL CHIP	33K	5%	1/10W	C80	1-124-234-00	ELECT	22uF	20%	16V		
R83	1-216-001-00	METAL CHIP	10	5%	1/10W	C81	1-164-232-11	CERAMIC CHIP	0.01uF		50V		
R84	1-216-101-00	METAL CHIP	150K	5%	1/10W	C82	1-136-157-00	FILM	0.022uF	5%	50V		
R85	1-216-075-00	METAL CHIP	12K	5%	1/10W	C83	1-164-004-11	CERAMIC CHIP	0.1uF	10%	25V		
R91	1-216-073-00	METAL CHIP	10K	5%	1/10W	C84	1-136-478-11	FILM	470PF	5%	630V		
R92	1-216-085-00	METAL CHIP	33K	5%	1/10W	C85	1-136-433-11	FILM	100PF	5%	630V		
R93	1-216-001-00	METAL CHIP	10	5%	1/10W	C86	1-163-143-00	CERAMIC CHIP	0.0012uF	5%	50V		
R94	1-216-101-00	METAL CHIP	150K	5%	1/10W	C87	1-136-273-00	FILM	75PF	5%	630V		
R95	1-216-075-00	METAL CHIP	12K	5%	1/10W	C88	1-163-003-11	CERAMIC CHIP	330PF	10%	50V		
		< VARIABLE RESISTOR >				C89	1-124-234-00	ELECT	22uF	20%	16V		
RV11	1-241-761-11	RES, ADJ, CARBON	1K			C90	1-107-584-11	CERAMIC	4PF	0.25PF	500V		
RV21	1-241-761-11	RES, ADJ, CARBON	1K			C91	1-164-232-11	CERAMIC CHIP	0.01uF		50V		
RV71	1-241-764-11	RES, ADJ, CARBON	10K			C92	1-136-157-00	FILM	0.022uF	5%	50V		
RV72	1-241-764-11	RES, ADJ, CARBON	10K			C93	1-164-004-11	CERAMIC CHIP	0.1uF	10%	25V		
RV81	1-241-786-11	RES, ADJ, CARBON	22K			C94	1-136-478-11	FILM	470PF	5%	630V		
RV91	1-241-786-11	RES, ADJ, CARBON	22K			C95	1-136-433-11	FILM	100PF	5%	630V		
		< RELAY >				C96	1-163-143-00	CERAMIC CHIP	0.0012uF	5%	50V		
RY31	1-515-913-11	RELAY				C97	1-136-273-00	FILM	75PF	5%	630V		
		< TRANSFORMER >				C98	1-163-003-11	CERAMIC CHIP	330PF	10%	50V		
T51	1-406-417-11	COIL, BIAS OSCILLATION				C99	1-164-005-11	CERAMIC CHIP	0.47uF		25V		
T81	1-433-381-11	TRANSFORMER, BIAS OSCILLATOR						< CONNECTOR >					
T91	1-433-381-11	TRANSFORMER, BIAS OSCILLATOR				* CNP31	1-580-782-11	CONNECTOR, BOARD TO BOARD	10P				
		< TEST PIN >				* CNP32	1-580-781-11	PIN, CONNECTOR (PC BOARD)	7P				
* TP81	1-568-449-11	HOUSING, CONNECTOR (PC BOARD)	3P			* CNP33	1-580-782-11	CONNECTOR, BOARD TO BOARD	10P				
		*****				* CNP71	1-564-719-11	PIN, CONNECTOR (SMALL TYPE)	3P				
						CNP72	1-764-902-11	CONNECTOR, FFC/FPC	4P				
						CNP75	1-564-718-11	PIN, CONNECTOR (SMALL TYPE)	2P				
								< DIODE >					
* A-2007-040-A		AUDIO (B) BOARD, COMPLETE				D31	8-719-404-46	DIODE	MA110				
		*****						< IC >					
		< CAPACITOR >				IC31	8-759-711-85	IC	NJM4580E-D				
C11	1-163-131-00	CERAMIC CHIP	390PF	5%	50V	IC81	8-759-106-56	IC	uPC1297CA				
C12	1-136-157-00	FILM	0.022uF	5%	50V			< COIL >					
C13	1-124-234-00	ELECT	22uF	20%	16V	L81	1-410-780-11	INDUCTOR	27mH				
C18	1-163-251-11	CERAMIC CHIP	100PF	5%	50V	L91	1-410-780-11	INDUCTOR	27mH				
C21	1-163-131-00	CERAMIC CHIP	390PF	5%	50V			< TRANSISTOR >					
C22	1-136-157-00	FILM	0.022uF	5%	50V	Q51	8-729-822-05	TRANSISTOR	2SD1622-ST-TD				
C23	1-124-234-00	ELECT	22uF	20%	16V	Q52	8-729-822-05	TRANSISTOR	2SD1622-ST-TD				
C28	1-163-251-11	CERAMIC CHIP	100PF	5%	50V	Q53	8-729-822-05	TRANSISTOR	2SD1622-ST-TD				
C31	1-124-234-00	ELECT	22uF	20%	16V	Q71	8-729-216-22	TRANSISTOR	2SA1162-G				
C32	1-124-234-00	ELECT	22uF	20%	16V								
C33	1-124-234-00	ELECT	22uF	20%	16V								

AUDIO (B)

DOLBY-S

Ref. No.	Part No.	Description	Remark
< RESISTOR >			
R11	1-216-099-00	METAL CHIP 120K 5%	1/10W
R12	1-216-025-00	RES,CHIP 100 5%	1/10W
R13	1-216-100-00	RES,CHIP 130K 5%	1/10W
R14	1-216-068-00	METAL CHIP 6.2K 5%	1/10W
R21	1-216-099-00	METAL CHIP 120K 5%	1/10W
R22	1-216-025-00	RES,CHIP 100 5%	1/10W
R23	1-216-100-00	RES,CHIP 130K 5%	1/10W
R24	1-216-068-00	METAL CHIP 6.2K 5%	1/10W
R31	1-216-033-00	METAL CHIP 220 5%	1/10W
R32	1-216-033-00	METAL CHIP 220 5%	1/10W
R33	1-216-065-00	RES,CHIP 4.7K 5%	1/10W
R51	1-216-097-00	RES,CHIP 100K 5%	1/10W
R52	1-216-097-00	RES,CHIP 100K 5%	1/10W
R53	1-216-073-00	METAL CHIP 10K 5%	1/10W
R54	1-216-309-00	METAL CHIP 5.6 5%	1/10W
R55	1-216-309-00	METAL CHIP 5.6 5%	1/10W
R57	1-216-298-00	METAL CHIP 2.2 5%	1/10W
R71	1-216-082-00	RES,CHIP 24K 5%	1/10W
R72	1-216-081-00	METAL CHIP 22K 5%	1/10W
R73	1-216-089-00	RES,CHIP 47K 5%	1/10W
R74	1-216-089-00	RES,CHIP 47K 5%	1/10W
R81	1-216-073-00	METAL CHIP 10K 5%	1/10W
R82	1-216-085-00	METAL CHIP 33K 5%	1/10W
R83	1-216-001-00	METAL CHIP 10 5%	1/10W
R84	1-216-101-00	METAL CHIP 150K 5%	1/10W
R85	1-216-075-00	METAL CHIP 12K 5%	1/10W
R91	1-216-073-00	METAL CHIP 10K 5%	1/10W
R92	1-216-085-00	METAL CHIP 33K 5%	1/10W
R93	1-216-001-00	METAL CHIP 10 5%	1/10W
R94	1-216-101-00	METAL CHIP 150K 5%	1/10W
R95	1-216-075-00	METAL CHIP 12K 5%	1/10W
< VARIABLE RESISTOR >			
RV11	1-241-761-11	RES, ADJ, CARBON 1K	
RV21	1-241-761-11	RES, ADJ, CARBON 1K	
RV71	1-241-764-11	RES, ADJ, CARBON 10K	
RV72	1-241-764-11	RES, ADJ, CARBON 10K	
RV81	1-241-786-11	RES, ADJ, CARBON 22K	
RV91	1-241-786-11	RES, ADJ, CARBON 22K	
< RELAY >			
RY31	1-515-913-11	RELAY	
< TRANSFORMER >			
T51	1-406-417-11	COIL, BIAS OSCILLATION	
T81	1-433-381-11	TRANSFORMER, BIAS OSCILLATOR	
T91	1-433-381-11	TRANSFORMER, BIAS OSCILLATOR	
< TEST PIN >			
* TP81	1-568-449-11	HOUSING, CONNECTOR (PC BOARD) 3P	

Ref. No.	Part No.	Description	Remark
*	A-2007-801-A	DOLBY-S BOARD, COMPLETE (WE825S)	

< CAPACITOR >			
C1	1-136-165-00	FILM 0.1uF 5%	50V
C2	1-163-012-00	CERAMIC CHIP 0.0018uF 10%	50V
C3	1-163-012-00	CERAMIC CHIP 0.0018uF 10%	50V
C4	1-164-222-11	CERAMIC CHIP 0.22uF	25V
C5	1-136-165-00	FILM 0.1uF 5%	50V
C6	1-136-165-00	FILM 0.1uF 5%	50V
C7	1-137-372-11	FILM 0.022uF 5%	50V
C8	1-164-222-11	CERAMIC CHIP 0.22uF	25V
C9	1-126-301-11	ELECT 1uF 20%	50V
C10	1-137-442-11	FILM 0.039uF 5%	50V
C11	1-163-007-11	CERAMIC CHIP 680PF 10%	50V
C12	1-164-717-11	CERAMIC CHIP 0.0082uF 5%	50V
C13	1-163-038-00	CERAMIC CHIP 0.1uF	25V
C14	1-124-465-00	ELECT 0.47uF 20%	50V
C15	1-164-222-11	CERAMIC CHIP 0.22uF	25V
C16	1-163-038-00	CERAMIC CHIP 0.1uF	25V
C17	1-124-465-00	ELECT 0.47uF 20%	50V
C18	1-163-038-00	CERAMIC CHIP 0.1uF	25V
C19	1-164-222-11	CERAMIC CHIP 0.22uF	25V
C20	1-163-035-00	CERAMIC CHIP 0.047uF	50V
C21	1-164-717-11	CERAMIC CHIP 0.0082uF 5%	50V
C22	1-164-161-11	CERAMIC CHIP 0.0022uF 10%	100V
C23	1-163-005-11	CERAMIC CHIP 470PF 10%	50V
C24	1-137-442-11	FILM 0.039uF 5%	50V
C25	1-136-165-00	FILM 0.1uF 5%	50V
C26	1-137-372-11	FILM 0.022uF 5%	50V
C28	1-163-038-00	CERAMIC CHIP 0.1uF	25V
< CONNECTOR >			
CN1	1-695-092-11	SOCKET, CONNECTOR 7P	
< IC >			
IC1	8-752-076-30	IC CXA1917AM-T6	
< JUMPER RESISTOR >			
J1	1-216-296-00	SHORT 0	
J2	1-216-296-00	SHORT 0	
J3	1-216-296-00	SHORT 0	
< RESISTOR >			
R1	1-216-685-11	METAL CHIP 27K 0.5%	1/10W
R2	1-208-811-11	RES,CHIP 16K 2%	1/10W
R3	1-208-791-11	RES,CHIP 2.4K 2%	1/10W
R4	1-208-799-11	RES,CHIP 5.1K 2%	1/10W
R5	1-216-689-11	METAL CHIP 39K 0.5%	1/10W
R6	1-216-689-11	METAL CHIP 39K 0.5%	1/10W
R7	1-216-615-11	METAL CHIP 33 0.5%	1/10W
R8	1-208-462-41	RES,CHIP 10K 2%	1/10W

Ref. No.	Part No.	Description	Remark
R9	1-208-812-11	RES,CHIP 18K 2%	1/10W
R10	1-216-615-11	METAL CHIP 33 0.5%	1/10W
R11	1-216-619-11	METAL CHIP 47 0.5%	1/10W
R12	1-216-684-11	METAL CHIP 24K 0.5%	1/10W
R13	1-216-615-11	METAL CHIP 33 0.5%	1/10W
R14	1-216-619-11	METAL CHIP 47 0.5%	1/10W
R15	1-216-655-11	METAL CHIP 1.5K 0.5%	1/10W
R16	1-216-678-11	METAL CHIP 13K 0.5%	1/10W
R17	1-216-673-11	METAL CHIP 8.2K 0.5%	1/10W
R18	1-208-462-41	RES,CHIP 10K 2%	1/10W
R19	1-208-462-41	RES,CHIP 10K 2%	1/10W
R20	1-216-689-11	METAL CHIP 39K 0.5%	1/10W

FL BOARD (SUPPLIED WITH MAIN BOARD, COMPLETE) *****			
* 3-377-337-11	HOLDER (FL)		
< CAPACITOR >			
C901	1-126-933-11	ELECT 100uF 20%	10V
C902	1-163-037-11	CERAMIC CHIP 0.022uF 10%	25V
< CONNECTOR >			
CNS901	1-770-247-11	SOCKET, CONNECTOR 41P	
< FLUORESCENT INDICATOR >			
FLT901	1-517-263-11	INDICATOR TUBE, FLUORESCENT	
< IC >			
IC901	8-749-014-66	IC NJL56H400	
< RESISTOR >			
R904	1-216-025-00	RES,CHIP 100 5%	1/10W
R905	1-216-097-00	RES,CHIP 100K 5%	1/10W (WE625)
R906	1-216-025-00	RES,CHIP 100 5%	1/10W
R911	1-216-051-00	METAL CHIP 1.2K 5%	1/10W
R912	1-216-055-00	METAL CHIP 1.8K 5%	1/10W
R913	1-216-059-00	METAL CHIP 2.7K 5%	1/10W
R914	1-216-063-00	RES,CHIP 3.9K 5%	1/10W
R915	1-216-069-00	METAL CHIP 6.8K 5%	1/10W
R916	1-216-077-00	METAL CHIP 15K 5%	1/10W
R917	1-216-089-00	RES,CHIP 47K 5%	1/10W
R921	1-216-051-00	METAL CHIP 1.2K 5%	1/10W
R922	1-216-055-00	METAL CHIP 1.8K 5%	1/10W
R923	1-216-059-00	METAL CHIP 2.7K 5%	1/10W
R924	1-216-063-00	RES,CHIP 3.9K 5%	1/10W
R925	1-216-069-00	METAL CHIP 6.8K 5%	1/10W
R926	1-216-077-00	METAL CHIP 15K 5%	1/10W
R927	1-216-089-00	RES,CHIP 47K 5%	1/10W
R931	1-216-051-00	METAL CHIP 1.2K 5%	1/10W

Ref. No.	Part No.	Description	Remark
R932	1-216-055-00	METAL CHIP 1.8K 5%	1/10W
R935	1-216-069-00	METAL CHIP 6.8K 5%	1/10W
R936	1-216-077-00	METAL CHIP 15K 5%	1/10W
R937	1-216-089-00	RES,CHIP 47K 5%	1/10W (WE825S)
R941	1-216-051-00	METAL CHIP 1.2K 5%	1/10W
R942	1-216-055-00	METAL CHIP 1.8K 5%	1/10W
R943	1-216-059-00	METAL CHIP 2.7K 5%	1/10W
R944	1-216-063-00	RES,CHIP 3.9K 5%	1/10W
R945	1-216-069-00	METAL CHIP 6.8K 5%	1/10W
R946	1-216-077-00	METAL CHIP 15K 5%	1/10W
R951	1-216-051-00	METAL CHIP 1.2K 5%	1/10W
R952	1-216-055-00	METAL CHIP 1.8K 5%	1/10W
R953	1-216-059-00	METAL CHIP 2.7K 5%	1/10W
R954	1-216-063-00	RES,CHIP 3.9K 5%	1/10W
< SWITCH >			
S911	1-554-303-21	SWITCH, TACTILE (■ CLEAR) (DECK A)	
S912	1-554-303-21	SWITCH, TACTILE (■ PAUSE) (DECK A)	
S913	1-554-303-21	SWITCH, TACTILE (▷ FRONT) (DECK A)	
S914	1-554-303-21	SWITCH, TACTILE (◁ BACK) (DECK A)	
S915	1-554-303-21	SWITCH, TACTILE (○ REC MUTING) (DECK A)	
S916	1-554-303-21	SWITCH, TACTILE (◀ (AMS)) (DECK B)	
S917	1-554-303-21	SWITCH, TACTILE (▶ (AMS)) (DECK B)	
S918	1-554-303-21	SWITCH, TACTILE (● REC) (DECK B)	
S921	1-554-303-21	SWITCH, TACTILE (■) (DECK B)	
S922	1-554-303-21	SWITCH, TACTILE (■ PAUSE) (DECK B)	
S923	1-554-303-21	SWITCH, TACTILE (▷ FRONT) (DECK B)	
S924	1-554-303-21	SWITCH, TACTILE (◁ BACK) (DECK B)	
S925	1-554-303-21	SWITCH, TACTILE (○ REC MUTING) (DECK B)	
S926	1-554-303-21	SWITCH, TACTILE (◀ (AMS)) (DECK A)	
S927	1-554-303-21	SWITCH, TACTILE (▶ (AMS)) (DECK A)	
S928	1-554-303-21	SWITCH, TACTILE (● REC) (DECK A)	
S931	1-554-303-21	SWITCH, TACTILE (RESET) (DECK A)	
S932	1-554-303-21	SWITCH, TACTILE (MEMORY) (DECK A)	
S936	1-762-567-11	SWITCH, SLIDE (DOLBY NR ON,OFF,FILTER)	
S937	1-762-608-11	SWITCH, SLIDE (DOLBY NR B,C)	(WE625/WE725)
S937	1-762-609-11	SWITCH, SLIDE (DOLBY NR B,C,S) (WE825S)	
S941	1-554-303-21	SWITCH, TACTILE (DISPLAY)	
S942	1-554-303-21	SWITCH, TACTILE (RMS START)	
S943	1-554-303-21	SWITCH, TACTILE (CHECK)	
S944	1-554-303-21	SWITCH, TACTILE (SET)	
S945	1-554-303-21	SWITCH, TACTILE (A+B REC)	
S946	1-554-303-21	SWITCH, TACTILE (HIGH/NORMAL)	
S951	1-554-303-21	SWITCH, TACTILE (RESET) (DECK B)	
S952	1-554-303-21	SWITCH, TACTILE (MEMORY) (DECK B)	
S953	1-554-303-21	SWITCH, TACTILE (DECK A)	
S954	1-554-303-21	SWITCH, TACTILE (DECK B)	

HEADPHONE

LEAF SW (A)

LEAF SW (B)

MAIN

Ref. No.	Part No.	Description	Remark
		HEADPHONE BOARD (SUPPLIED WITH MAIN BOARD, COMPLETE) *****	
		< JACK >	
J502	1-568-519-41	JACK, LARGE TYPE (PHONES)	

*	1-634-841-14	LEAF SW (A) BOARD (WE725/WE825S)	
*	1-638-020-11	LEAF SW (A) BOARD (WE625) *****	
		< CONNECTOR >	
* CNP81	1-568-850-11	SOCKET, CONNECTOR 7P (WE625)	
* CNP81	1-568-852-11	SOCKET, CONNECTOR 9P (WE725/WE825S)	
		< PHOTO REFLECTOR >	
IC81	8-749-924-10	PHOTO REFLECTOR NJL5165K-B(H1)	
IC82	8-749-924-10	PHOTO REFLECTOR NJL5165K-B(H1) (WE725/WE825S)	
		< RESISTOR >	
R81	1-249-414-11	CARBON 560 5% 1/4W	
R82	1-247-818-11	CARBON 300 5% 1/4W	
R83	1-247-834-11	CARBON 1.3K 5% 1/4W	
R84	1-249-417-11	CARBON 1K 5% 1/4W	
R85	1-249-408-11	CARBON 180 5% 1/4W	
R86	1-249-408-11	CARBON 180 5% 1/4W (WE725/WE825S)	
		< SWITCH >	
S81	1-571-958-11	SWITCH, PUSH (1 KEY) (STOP)	
S82	1-571-281-21	SWITCH, LEAF (CrO2)	
S83	1-571-281-21	SWITCH, LEAF (METAL)	
S84	1-571-281-21	SWITCH, LEAF (ERASE PROOF) (SIDE A)	
S85	1-571-281-21	SWITCH, LEAF (ERASE PROOF) (SIDE B)	
S86	1-571-281-21	SWITCH, LEAF (HALF)	

*	1-634-841-14	LEAF SW (B) BOARD (WE725/WE825S)	
*	1-638-020-11	LEAF SW (B) BOARD (WE625) *****	
		< CONNECTOR >	
* CNP81	1-568-850-11	SOCKET, CONNECTOR 7P (WE625)	
* CNP81	1-568-852-11	SOCKET, CONNECTOR 9P (WE725/WE825S)	
		< PHOTO REFLECTOR >	
IC81	8-749-924-10	PHOTO REFLECTOR NJL5165K-B(H1)	
IC82	8-749-924-10	PHOTO REFLECTOR NJL5165K-B(H1) (WE725/WE825S)	

Ref. No.	Part No.	Description	Remark
		< RESISTOR >	
R81	1-249-414-11	CARBON 560 5% 1/4W	
R82	1-247-818-11	CARBON 300 5% 1/4W	
R83	1-247-834-11	CARBON 1.3K 5% 1/4W	
R84	1-249-417-11	CARBON 1K 5% 1/4W	
R85	1-249-408-11	CARBON 180 5% 1/4W	
R86	1-249-408-11	CARBON 180 5% 1/4W (WE725/WE825S)	
		< SWITCH >	
S81	1-571-958-11	SWITCH, PUSH (1 KEY) (STOP)	
S82	1-571-281-21	SWITCH, LEAF (CrO2)	
S83	1-571-281-21	SWITCH, LEAF (METAL)	
S84	1-571-281-21	SWITCH, LEAF (ERASE PROOF) (SIDE A)	
S85	1-571-281-21	SWITCH, LEAF (ERASE PROOF) (SIDE B)	
S86	1-571-281-21	SWITCH, LEAF (HALF)	

*	A-2007-758-A	MAIN BOARD, COMPLETE (WE725)	
*	A-2007-761-A	MAIN BOARD, COMPLETE (WE625:US,CND)	
*	A-2007-762-A	MAIN BOARD, COMPLETE (WE625:AUS)	
*	A-2007-763-A	MAIN BOARD, COMPLETE (WE625:SP,MY)	
*	A-2007-764-A	MAIN BOARD, COMPLETE (WE625:CH)	
*	A-2007-765-A	MAIN BOARD, COMPLETE (WE825S:AEP,UK)	
*	A-2007-802-A	MAIN BOARD, COMPLETE (WE825S:US) (INCLUDING FL BOARD, HEADPHONE BOARD, REC VOL BOARD, SW (A) BOARD, SW (B) BOARD, SW (C) BOARD, TRANS (A) BOARD, TRANS (B) BOARD)	

		< CAPACITOR >	
C102	1-126-961-11	ELECT 2.2uF 20% 50V	
C103	1-163-017-00	CERAMIC CHIP 0.0047uF 5% 50V	
C104	1-126-963-11	ELECT 4.7uF 20% 50V	
C106	1-126-963-11	ELECT 4.7uF 20% 50V	
C107	1-126-964-11	ELECT 10uF 20% 50V	
C108	1-130-495-00	MYLAR 0.1uF 5% 50V	
C109	1-130-493-00	MYLAR 0.068uF 5% 50V	
C110	1-126-964-11	ELECT 10uF 20% 50V	
C111	1-126-959-11	ELECT 0.47uF 20% 50V	
C112	1-126-963-11	ELECT 4.7uF 20% 50V	
C113	1-126-963-11	ELECT 4.7uF 20% 50V	
C114	1-135-149-21	TANTALUM CHIP 2.2uF 20% 10V	
C115	1-163-016-00	CERAMIC CHIP 0.0039uF 10% 50V	
C116	1-126-959-11	ELECT 0.47uF 20% 50V	
C117	1-126-963-11	ELECT 4.7uF 20% 50V	
C121	1-163-009-11	CERAMIC CHIP 0.001uF 10% 50V	
C202	1-126-961-11	ELECT 2.2uF 20% 50V	

Ref. No.	Part No.	Description	Remark	Ref. No.	Part No.	Description	Remark
C203	1-163-017-00	CERAMIC CHIP	0.0047uF 5% 50V	C710	1-126-935-11	ELECT	470uF 20% 6.3V
C204	1-126-963-11	ELECT	4.7uF 20% 50V	C711	1-126-947-11	ELECT	47uF 20% 35V
C206	1-126-963-11	ELECT	4.7uF 20% 50V	C801	1-126-933-11	ELECT	100uF 20% 10V
C207	1-126-964-11	ELECT	10uF 20% 50V	C803	1-126-959-11	ELECT	0.47uF 20% 50V
C208	1-130-495-00	MYLAR	0.1uF 5% 50V	C810	1-163-037-11	CERAMIC CHIP	0.022uF 10% 25V
C209	1-130-493-00	MYLAR	0.068uF 5% 50V	< CONNECTOR >			
C210	1-126-964-11	ELECT	10uF 20% 50V	CN101	1-695-087-11	PIN, CONNECTOR (PC BOARD) 7P (WE825S)	
C211	1-126-959-11	ELECT	0.47uF 20% 50V	CN201	1-695-087-11	PIN, CONNECTOR (PC BOARD) 7P (WE825S)	
C212	1-126-963-11	ELECT	4.7uF 20% 50V	* CN501	1-691-916-11	CONNECTOR, BOARD TO BOARD 10P	
C213	1-126-963-11	ELECT	4.7uF 20% 50V	* CN502	1-691-916-11	CONNECTOR, BOARD TO BOARD 10P	
C214	1-135-149-21	TANTALUM CHIP	2.2uF 20% 10V	* CN503	1-691-916-11	CONNECTOR, BOARD TO BOARD 10P	
C215	1-163-016-00	CERAMIC CHIP	0.0039uF 10% 50V	* CN504	1-691-916-11	CONNECTOR, BOARD TO BOARD 10P	
C216	1-126-959-11	ELECT	0.47uF 20% 50V	* CNA801	1-568-954-11	PIN, CONNECTOR 5P (US,CND)	
C217	1-126-963-11	ELECT	4.7uF 20% 50V	* CNA803	1-568-934-11	PIN, CONNECTOR 7P	
C221	1-163-009-11	CERAMIC CHIP	0.001uF 10% 50V	CNA806	1-506-468-11	PIN, CONNECTOR 3P	
C401	1-165-319-11	CERAMIC CHIP	0.1uF 50V	* CNA807	1-568-955-11	PIN, CONNECTOR 6P	
C451	1-126-964-11	ELECT	10uF 20% 50V	CNM701	1-766-269-11	PIN, CONNECTOR (PC BOARD) 7P	
C461	1-126-964-11	ELECT	10uF 20% 50V	CNS802	1-770-246-11	SOCKET, CONNECTOR 41P	
C501	1-126-964-11	ELECT	10uF 20% 50V	* CNS804	1-568-826-11	SOCKET, CONNECTOR 7P (WE625)	
C502	1-126-964-11	ELECT	10uF 20% 50V	* CNS804	1-568-828-11	SOCKET, CONNECTOR 9P (WE725/WE825S)	
C503	1-126-964-11	ELECT	10uF 20% 50V	* CNS805	1-568-826-11	SOCKET, CONNECTOR 7P (WE625)	
C505	1-126-960-11	ELECT	1uF 20% 50V	* CNS805	1-568-828-11	SOCKET, CONNECTOR 9P (WE725/WE825S)	
C506	1-130-491-00	MYLAR	0.047uF 5% 50V	< DIODE >			
C507	1-130-498-00	MYLAR	0.18uF 5% 50V	D101	8-719-978-24	DIODE DTZ-TT11-5.6A	
C508	1-126-959-11	ELECT	0.47uF 20% 50V	D201	8-719-978-24	DIODE DTZ-TT11-5.6A	
C509	1-126-965-11	ELECT	22uF 20% 50V	D401	8-719-016-74	DIODE 1SS352	
C510	1-126-960-11	ELECT	1uF 20% 50V	D521	8-719-016-74	DIODE 1SS352	
C511	1-126-916-11	ELECT	1000uF 20% 6.3V	D522	8-719-016-74	DIODE 1SS352	
C512	1-126-925-11	ELECT	470uF 20% 10V	D601	8-719-016-74	DIODE 1SS352	
C514	1-126-767-11	ELECT	1000uF 20% 16V	D602	8-719-016-74	DIODE 1SS352 (WE725/WE825S)	
C515	1-126-767-11	ELECT	1000uF 20% 16V	D701	8-719-200-02	DIODE 10E2	
C516	1-126-959-11	ELECT	0.47uF 20% 50V	D702	8-719-200-02	DIODE 10E2	
C521	1-130-476-00	MYLAR	0.0027uF 5% 50V	D703	8-719-200-02	DIODE 10E2	
C522	1-130-494-11	MYLAR	0.082uF 5% 50V	D704	8-719-200-02	DIODE 10E2	
C523	1-130-491-00	MYLAR	0.047uF 5% 50V	D705	8-719-016-74	DIODE 1SS352	
C524	1-164-161-11	CERAMIC CHIP	0.0022uF 10% 100V	D706	8-719-016-74	DIODE 1SS352	
C530	1-126-965-11	ELECT	22uF 20% 50V	D707	8-719-200-02	DIODE 10E2	
C561	1-136-168-00	FILM	0.18uF 5% 50V	D708	8-719-016-74	DIODE 1SS352	
C562	1-130-483-00	MYLAR	0.01uF 5% 50V	D709	8-719-978-24	DIODE DTZ-TT11-5.6A	
C563	1-136-175-00	FILM	0.68uF 5% 50V	D710	8-719-978-24	DIODE DTZ-TT11-5.6A	
C601	1-165-319-11	CERAMIC CHIP	0.1uF 50V	D711	8-719-978-24	DIODE DTZ-TT11-5.6A	
C602	1-165-319-11	CERAMIC CHIP	0.1uF 50V	D712	8-719-105-99	DIODE RD6.2M-B1	
C603	1-163-003-11	CERAMIC CHIP	330PF 10% 50V	D713	8-719-016-74	DIODE 1SS352	
C604	1-163-003-11	CERAMIC CHIP	330PF 10% 50V	D714	8-719-016-74	DIODE 1SS352	
C701	1-128-547-11	ELECT	6800uF 20% 16V	D715	8-719-016-74	DIODE 1SS352	
C702	1-126-937-11	ELECT	4700uF 20% 16V	D716	8-719-977-11	DIODE DTZ6.8A	
C703	1-126-960-11	ELECT	1uF 20% 50V	D801	8-719-016-74	DIODE 1SS352	
C704	1-126-969-11	ELECT	220uF 20% 50V	D802	8-719-016-74	DIODE 1SS352	
C705	1-126-963-11	ELECT	4.7uF 20% 50V	D803	8-719-016-74	DIODE 1SS352	
C706	1-126-926-11	ELECT	1000uF 20% 10V	D804	8-719-016-74	DIODE 1SS352	
C707	1-126-926-11	ELECT	1000uF 20% 10V				
C708	1-126-963-11	ELECT	4.7uF 20% 50V				
C709	1-126-963-11	ELECT	4.7uF 20% 50V				

MAIN

Ref. No.	Part No.	Description	Remark	Ref. No.	Part No.	Description	Remark
		< IC >					
IC501	8-752-075-27	IC CXA1878Q		Q703	8-729-141-83	TRANSISTOR 2SB1094-LK	
IC502	8-759-636-55	IC M5218AFP		Q704	8-729-010-29	TRANSISTOR MSD601-RST1	
IC504	8-752-070-67	IC CXA1597P		Q705	8-729-421-22	TRANSISTOR UN2211 (US,CND)	
IC561	8-759-100-96	IC μ PC4558G2		Q706	8-729-421-22	TRANSISTOR UN2211 (US,CND)	
IC601	8-759-822-38	IC LA6510		Q707	8-729-010-05	TRANSISTOR MSB709-RT1	
IC701	8-759-100-96	IC μ PC4558G2		Q708	8-729-140-04	TRANSISTOR 2SB1116A-L	
IC801	8-752-892-34	IC CXP82432A-006Q		Q801	8-729-421-19	TRANSISTOR UN2213	
IC802	8-759-165-82	IC PST600E-T		Q802	8-729-010-29	TRANSISTOR MSD601-RST1	
IC803	8-759-009-06	IC MC14052BF				< RESISTOR >	
IC804	8-759-009-06	IC MC14052BF		R101	1-216-073-00	METAL CHIP 10K 5%	1/10W
IC805	8-759-009-19	IC MC14081BF		R102	1-216-105-00	RES,CHIP 220K 5%	1/10W
IC806	8-759-009-06	IC MC14052BF		R103	1-216-097-00	RES,CHIP 100K 5%	1/10W
IC807	8-759-032-11	IC MC74HC04AF		R104	1-216-055-00	METAL CHIP 1.8K 5%	1/10W
IC808	8-759-009-06	IC MC14052BF		R105	1-216-061-00	METAL CHIP 3.3K 5%	1/10W
IC809	8-759-032-11	IC MC74HC04AF		R106	1-216-060-00	RES,CHIP 3K 5%	1/10W
		< JACK >		R107	1-216-049-11	RES,CHIP 1K 5%	1/10W
* J401	1-764-188-11	JACK (SMALL TYPE) (DIA. 3.5) (S-LINK CONTROL A1)		R108	1-216-063-00	RES,CHIP 3.9K 5%	1/10W
* J402	1-764-188-11	JACK (SMALL TYPE) (DIA. 3.5) (S-LINK CONTROL A1)		R109	1-216-073-00	METAL CHIP 10K 5%	1/10W
J501	1-770-614-11	JACK, PIN 4P (LINE IN/OUT)		R110	1-216-065-00	RES,CHIP 4.7K 5%	1/10W
		< LOW PASS FILTER >		R111	1-216-057-00	METAL CHIP 2.2K 5%	1/10W
LPF101	1-233-271-11	FILTER, LOW PASS		R112	1-216-075-00	METAL CHIP 12K 5%	1/10W
LPF201	1-233-271-11	FILTER, LOW PASS		R113	1-216-049-11	RES,CHIP 1K 5%	1/10W
		< TRANSISTOR >		R114	1-216-057-00	METAL CHIP 2.2K 5%	1/10W
Q101	8-729-900-74	TRANSISTOR DTC143TS		R115	1-216-081-00	METAL CHIP 22K 5%	1/10W
Q102	8-729-922-37	TRANSISTOR 2SD2144S		R116	1-216-061-00	METAL CHIP 3.3K 5%	1/10W
Q201	8-729-900-74	TRANSISTOR DTC143TS		R117	1-216-073-00	METAL CHIP 10K 5%	1/10W
Q202	8-729-922-37	TRANSISTOR 2SD2144S		R118	1-216-033-00	METAL CHIP 220 5%	1/10W
Q401	8-729-010-29	TRANSISTOR MSD601-RST1		R119	1-216-049-11	RES,CHIP 1K 5%	1/10W
Q451	8-729-010-05	TRANSISTOR MSB709-RT1		R120	1-216-089-00	RES,CHIP 47K 5%	1/10W
Q452	8-729-424-08	TRANSISTOR UN2111		R121	1-216-089-00	RES,CHIP 47K 5%	1/10W
Q453	8-729-421-22	TRANSISTOR UN2211		R122	1-216-073-00	METAL CHIP 10K 5%	1/10W
Q461	8-729-010-05	TRANSISTOR MSB709-RT1		R123	1-216-061-00	METAL CHIP 3.3K 5%	1/10W
Q462	8-729-424-08	TRANSISTOR UN2111		R124	1-216-295-00	SHORT 0 (WE625/WE725)	
Q463	8-729-421-22	TRANSISTOR UN2211		R201	1-216-073-00	METAL CHIP 10K 5%	1/10W
Q501	8-729-010-05	TRANSISTOR MSB709-RT1		R202	1-216-105-00	RES,CHIP 220K 5%	1/10W
Q502	8-729-010-29	TRANSISTOR MSD601-RST1		R203	1-216-097-00	RES,CHIP 100K 5%	1/10W
Q503	8-729-010-29	TRANSISTOR MSD601-RST1		R204	1-216-055-00	METAL CHIP 1.8K 5%	1/10W
Q601	8-729-421-22	TRANSISTOR UN2211		R205	1-216-061-00	METAL CHIP 3.3K 5%	1/10W
Q602	8-729-421-22	TRANSISTOR UN2211		R206	1-216-060-00	RES,CHIP 3K 5%	1/10W
Q603	8-729-424-08	TRANSISTOR UN2111 (WE725/WE825S)		R207	1-216-049-11	RES,CHIP 1K 5%	1/10W
Q604	8-729-801-93	TRANSISTOR 2SD1387		R208	1-216-063-00	RES,CHIP 3.9K 5%	1/10W
Q605	8-729-801-93	TRANSISTOR 2SD1387		R209	1-216-073-00	METAL CHIP 10K 5%	1/10W
Q606	8-729-421-22	TRANSISTOR UN2211 (WE725/WE825S)		R210	1-216-065-00	RES,CHIP 4.7K 5%	1/10W
Q607	8-729-424-08	TRANSISTOR UN2111 (WE725/WE825S)		R211	1-216-057-00	METAL CHIP 2.2K 5%	1/10W
Q621	8-729-010-05	TRANSISTOR MSB709-RT1 (WE725/WE825S)		R212	1-216-075-00	METAL CHIP 12K 5%	1/10W
Q701	8-729-141-83	TRANSISTOR 2SB1094-LK		R213	1-216-049-11	RES,CHIP 1K 5%	1/10W
Q702	8-729-209-15	TRANSISTOR 2SD2012		R214	1-216-057-00	METAL CHIP 2.2K 5%	1/10W
				R215	1-216-081-00	METAL CHIP 22K 5%	1/10W
				R216	1-216-061-00	METAL CHIP 3.3K 5%	1/10W
				R217	1-216-073-00	METAL CHIP 10K 5%	1/10W
				R218	1-216-033-00	METAL CHIP 220 5%	1/10W
				R219	1-216-049-11	RES,CHIP 1K 5%	1/10W

Ref. No.	Part No.	Description	Quantity	Unit	Cost	Remark	Ref. No.	Part No.	Description	Quantity	Unit	Cost	Remark
R220	1-216-089-00	RES,CHIP	47K		5%	1/10W	R579	1-216-067-00	METAL CHIP	5.6K		5%	1/10W
R221	1-216-089-00	RES,CHIP	47K		5%	1/10W	R580	1-216-059-00	METAL CHIP	2.7K		5%	1/10W
R222	1-216-073-00	METAL CHIP	10K		5%	1/10W	R581	1-216-065-00	RES,CHIP	4.7K		5%	1/10W
R223	1-216-061-00	METAL CHIP	3.3K		5%	1/10W	R582	1-216-065-00	RES,CHIP	4.7K		5%	1/10W
R224	1-216-295-00	SHORT	0			(WE625/WE725)	R583	1-216-070-00	METAL CHIP	7.5K		5%	1/10W
R401	1-216-073-00	METAL CHIP	10K		5%	1/10W	R584	1-216-075-00	METAL CHIP	12K		5%	1/10W
R402	1-216-049-11	RES,CHIP	1K		5%	1/10W	R585	1-216-071-00	METAL CHIP	8.2K		5%	1/10W
R403	1-216-065-00	RES,CHIP	4.7K		5%	1/10W	R586	1-216-071-00	METAL CHIP	8.2K		5%	1/10W
R404	1-216-073-00	METAL CHIP	10K		5%	1/10W	R587	1-216-059-00	METAL CHIP	2.7K		5%	1/10W
R405	1-216-001-00	METAL CHIP	10		5%	1/10W	R588	1-216-067-00	METAL CHIP	5.6K		5%	1/10W
R451	1-216-059-00	METAL CHIP	2.7K		5%	1/10W	R601	1-216-025-00	RES,CHIP	100		5%	1/10W
R452	1-216-059-00	METAL CHIP	2.7K		5%	1/10W	R602	1-216-025-00	RES,CHIP	100		5%	1/10W
R453	1-216-059-00	METAL CHIP	2.7K		5%	1/10W	R603	1-216-081-00	METAL CHIP	22K		5%	1/10W
R461	1-216-059-00	METAL CHIP	2.7K		5%	1/10W	R604	1-216-081-00	METAL CHIP	22K		5%	1/10W
R462	1-216-059-00	METAL CHIP	2.7K		5%	1/10W	R605	1-216-075-00	METAL CHIP	12K		5%	1/10W
R463	1-216-059-00	METAL CHIP	2.7K		5%	1/10W	R606	1-216-075-00	METAL CHIP	12K		5%	1/10W
R501	1-208-816-11	RES,CHIP	27K		0.50%	1/10W	R607	1-216-076-00	METAL CHIP	13K		5%	1/10W
R502	1-208-813-11	RES,CHIP	20K		0.50%	1/10W	R608	1-216-076-00	METAL CHIP	13K		5%	1/10W
R503	1-216-049-11	RES,CHIP	1K		5%	1/10W	R609	1-216-076-00	METAL CHIP	13K		5%	1/10W
R504	1-216-071-00	METAL CHIP	8.2K		5%	1/10W	R610	1-216-076-00	METAL CHIP	13K		5%	1/10W
R505	1-216-121-00	RES,CHIP	1M		5%	1/10W	R613	1-216-070-00	METAL CHIP	7.5K		5%	1/10W
R506	1-216-073-00	METAL CHIP	10K		5%	1/10W	R614	1-216-070-00	METAL CHIP	7.5K		5%	1/10W
R507	1-216-073-00	METAL CHIP	10K		5%	1/10W	R615	1-216-072-00	METAL CHIP	9.1K		5%	1/10W
R508	1-216-041-00	METAL CHIP	470		5%	1/10W	R616	1-216-072-00	METAL CHIP	9.1K		5%	1/10W
R509	1-216-049-11	RES,CHIP	1K		5%	1/10W	R617	1-216-073-00	METAL CHIP	10K		5%	1/10W
R510	1-216-089-00	RES,CHIP	47K		5%	1/10W	R618	1-216-057-00	METAL CHIP	2.2K		5%	1/10W
R511	1-216-073-00	METAL CHIP	10K		5%	1/10W	R619	1-216-073-00	METAL CHIP	10K		5%	1/10W
R512	1-216-041-00	METAL CHIP	470		5%	1/10W	R620	1-216-057-00	METAL CHIP	2.2K		5%	1/10W
R513	1-216-089-00	RES,CHIP	47K		5%	1/10W	R622	1-216-066-00	METAL CHIP	5.1K		5%	1/10W
R514	1-216-025-00	RES,CHIP	100		5%	1/10W	R623	1-216-089-00	RES,CHIP	47K		5%	1/10W (WE725/WE825S)
R515	1-208-816-11	RES,CHIP	27K		0.50%	1/10W	R624	1-216-089-00	RES,CHIP	47K		5%	1/10W (WE725/WE825S)
R521	1-216-081-00	METAL CHIP	22K		5%	1/10W	R701	1-249-414-11	CARBON	560		5%	1/4W
R522	1-216-067-00	METAL CHIP	5.6K		5%	1/10W	R702	1-216-073-00	METAL CHIP	10K		5%	1/10W
R523	1-216-689-11	METAL CHIP	39K		0.5%	1/10W	R703	1-216-061-00	METAL CHIP	3.3K		5%	1/10W
R524	1-216-065-00	RES,CHIP	4.7K		5%	1/10W	R704	1-216-065-00	RES,CHIP	4.7K		5%	1/10W
R525	1-216-065-00	RES,CHIP	4.7K		5%	1/10W	R705	1-216-069-00	METAL CHIP	6.8K		5%	1/10W
R526	1-216-097-00	RES,CHIP	100K		5%	1/10W	R706	1-216-053-00	METAL CHIP	1.5K		5%	1/10W
R527	1-216-097-00	RES,CHIP	100K		5%	1/10W	R707	1-216-073-00	METAL CHIP	10K		5%	1/10W
R528	1-216-063-00	RES,CHIP	3.9K		5%	1/10W	R708	1-216-053-00	METAL CHIP	1.5K		5%	1/10W
R529	1-216-041-00	METAL CHIP	470		5%	1/10W	R709	1-216-065-00	RES,CHIP	4.7K		5%	1/10W
R530	1-216-073-00	METAL CHIP	10K		5%	1/10W	R710	1-216-049-11	RES,CHIP	1K		5%	1/10W
R561	1-216-089-00	RES,CHIP	47K		5%	1/10W	R711	1-216-069-00	METAL CHIP	6.8K		5%	1/10W
R562	1-216-089-00	RES,CHIP	47K		5%	1/10W	R712	1-216-069-00	METAL CHIP	6.8K		5%	1/10W
R563	1-216-089-00	RES,CHIP	47K		5%	1/10W	R713	1-216-049-11	RES,CHIP	1K		5%	1/10W
R564	1-216-081-00	METAL CHIP	22K		5%	1/10W	R714	1-216-073-00	METAL CHIP	10K		5%	1/10W
R565	1-216-081-00	METAL CHIP	22K		5%	1/10W	R715	1-216-059-00	METAL CHIP	2.7K		5%	1/10W
R571	1-216-051-00	METAL CHIP	1.2K		5%	1/10W	R716	1-216-081-00	METAL CHIP	22K		5%	1/10W
R572	1-216-067-00	METAL CHIP	5.6K		5%	1/10W	R717	1-216-073-00	METAL CHIP	10K		5%	1/10W
R573	1-216-069-00	METAL CHIP	6.8K		5%	1/10W	R718	1-216-689-11	METAL CHIP	39K		0.5%	1/10W
R575	1-216-070-00	METAL CHIP	7.5K		5%	1/10W	R719	1-216-075-00	METAL CHIP	12K		5%	1/10W
R576	1-216-075-00	METAL CHIP	12K		5%	1/10W							
R577	1-216-071-00	METAL CHIP	8.2K		5%	1/10W							
R578	1-216-071-00	METAL CHIP	8.2K		5%	1/10W							

MAIN

REC VOL

Ref. No.	Part No.	Description	Remark
△ R720	1-219-136-11	FUSIBLE	0.22 10% 1/4W F
R721	1-216-073-00	METAL CHIP	10K 5% 1/10W
△ R722	1-219-137-11	FUSIBLE	0.33 10% 1/4W F
△ R723	1-219-137-11	FUSIBLE	0.33 10% 1/4W F
R801	1-216-097-00	RES,CHIP	100K 5% 1/10W
R802	1-216-073-00	METAL CHIP	10K 5% 1/10W
R803	1-216-073-00	METAL CHIP	10K 5% 1/10W (WE725/WE825S)
R804	1-216-067-00	METAL CHIP	5.6K 5% 1/10W (WE725/WE825S)
R806	1-216-081-00	METAL CHIP	22K 5% 1/10W
R807	1-216-097-00	RES,CHIP	100K 5% 1/10W
R808	1-216-097-00	RES,CHIP	100K 5% 1/10W
R809	1-216-049-11	RES,CHIP	1K 5% 1/10W
R810	1-216-025-00	RES,CHIP	100 5% 1/10W
R811	1-216-073-00	METAL CHIP	10K 5% 1/10W
R812	1-216-073-00	METAL CHIP	10K 5% 1/10W
R813	1-216-073-00	METAL CHIP	10K 5% 1/10W
R814	1-216-073-00	METAL CHIP	10K 5% 1/10W
R815	1-216-073-00	METAL CHIP	10K 5% 1/10W
R816	1-216-025-00	RES,CHIP	100 5% 1/10W
R817	1-216-025-00	RES,CHIP	100 5% 1/10W
R818	1-216-025-00	RES,CHIP	100 5% 1/10W
R819	1-216-025-00	RES,CHIP	100 5% 1/10W
R820	1-216-025-00	RES,CHIP	100 5% 1/10W
R821	1-216-025-00	RES,CHIP	100 5% 1/10W
R822	1-216-025-00	RES,CHIP	100 5% 1/10W
R823	1-216-025-00	RES,CHIP	100 5% 1/10W
R824	1-216-025-00	RES,CHIP	100 5% 1/10W
R825	1-216-025-00	RES,CHIP	100 5% 1/10W
R826	1-216-025-00	RES,CHIP	100 5% 1/10W
R827	1-216-025-00	RES,CHIP	100 5% 1/10W
R828	1-216-025-00	RES,CHIP	100 5% 1/10W
R829	1-216-025-00	RES,CHIP	100 5% 1/10W
R830	1-216-025-00	RES,CHIP	100 5% 1/10W
R831	1-216-097-00	RES,CHIP	100K 5% 1/10W
R832	1-216-097-00	RES,CHIP	100K 5% 1/10W
R833	1-216-097-00	RES,CHIP	100K 5% 1/10W
R834	1-216-097-00	RES,CHIP	100K 5% 1/10W
R841	1-216-073-00	METAL CHIP	10K 5% 1/10W
R842	1-216-080-00	METAL CHIP	20K 5% 1/10W
R843	1-216-057-00	METAL CHIP	2.2K 5% 1/10W
R844	1-216-092-00	RES,CHIP	62K 5% 1/10W
R845	1-216-084-00	METAL CHIP	30K 5% 1/10W
R846	1-216-077-00	METAL CHIP	15K 5% 1/10W
R847	1-216-070-00	METAL CHIP	7.5K 5% 1/10W
R848	1-216-073-00	METAL CHIP	10K 5% 1/10W
R849	1-216-073-00	METAL CHIP	10K 5% 1/10W
R850	1-216-073-00	METAL CHIP	10K 5% 1/10W
R851	1-216-073-00	METAL CHIP	10K 5% 1/10W
R852	1-216-083-00	METAL CHIP	27K 5% 1/10W
R853	1-216-083-00	METAL CHIP	27K 5% 1/10W
R854	1-216-083-00	METAL CHIP	27K 5% 1/10W

Ref. No.	Part No.	Description	Remark
R855	1-216-083-00	METAL CHIP	27K 5% 1/10W
R861	1-216-073-00	METAL CHIP	10K 5% 1/10W
R862	1-216-080-00	METAL CHIP	20K 5% 1/10W
R863	1-216-057-00	METAL CHIP	2.2K 5% 1/10W
R864	1-216-092-00	RES,CHIP	62K 5% 1/10W
R865	1-216-084-00	METAL CHIP	30K 5% 1/10W
R866	1-216-077-00	METAL CHIP	15K 5% 1/10W
R867	1-216-070-00	METAL CHIP	7.5K 5% 1/10W
R868	1-216-073-00	METAL CHIP	10K 5% 1/10W
R869	1-216-073-00	METAL CHIP	10K 5% 1/10W
R870	1-216-073-00	METAL CHIP	10K 5% 1/10W
R871	1-216-073-00	METAL CHIP	10K 5% 1/10W
R872	1-216-083-00	METAL CHIP	27K 5% 1/10W
R873	1-216-083-00	METAL CHIP	27K 5% 1/10W
R874	1-216-083-00	METAL CHIP	27K 5% 1/10W
R875	1-216-083-00	METAL CHIP	27K 5% 1/10W
R877	1-216-081-00	METAL CHIP	22K 5% 1/10W
R878	1-216-081-00	METAL CHIP	22K 5% 1/10W
R881	1-216-057-00	METAL CHIP	2.2K 5% 1/10W
R882	1-216-057-00	METAL CHIP	2.2K 5% 1/10W
R883	1-216-057-00	METAL CHIP	2.2K 5% 1/10W
R884	1-216-083-00	METAL CHIP	27K 5% 1/10W
R885	1-216-083-00	METAL CHIP	27K 5% 1/10W (WE725/WE825S)
R885	1-216-295-00	SHORT	0 (WE625)
R886	1-216-057-00	METAL CHIP	2.2K 5% 1/10W
R891	1-216-057-00	METAL CHIP	2.2K 5% 1/10W
R892	1-216-057-00	METAL CHIP	2.2K 5% 1/10W
R893	1-216-057-00	METAL CHIP	2.2K 5% 1/10W
R894	1-216-083-00	METAL CHIP	27K 5% 1/10W
R895	1-216-083-00	METAL CHIP	27K 5% 1/10W (WE725/WE825S)
R895	1-216-295-00	SHORT	0 (WE625)
R896	1-216-057-00	METAL CHIP	2.2K 5% 1/10W
< VARIABLE RESISTOR >			
RV101	1-241-764-11	RES, ADJ, CARBON	10K
RV102	1-241-764-11	RES, ADJ, CARBON	10K
RV201	1-241-764-11	RES, ADJ, CARBON	10K
RV202	1-241-764-11	RES, ADJ, CARBON	10K
RV601	1-241-765-11	RES, ADJ, CARBON	22K (WE725/WE825S)
< VIBRATOR >			
X801	1-579-175-11	VIBRATOR, CERAMIC	(10MHz)

REC VOL BOARD (SUPPLIED WITH MAIN BOARD, COMPLETE) *****			
< DIODE >			
D901	8-719-313-43	LED SEL6210S-TH10	(CD SYNCHRO)
D902	8-719-313-43	LED SEL6210S-TH10	(AUTO)

<p>The components identified by mark △ or dotted line with mark. △ are critical for safety. Replace only with part number specified.</p>	<p>Les composants identifiés par une marque △ sont critiques pour la sécurité. Ne les remplacer que par une pièce portant le numéro spécifié.</p>
--	---

REC VOL

SW (A)

SW (B)

SW (C)

TRANS (A)

TRANS (B)

Ref. No.	Part No.	Description	Remark
		< TRANSISTOR >	
Q901	8-729-424-08	TRANSISTOR UN2111	
Q902	8-729-424-08	TRANSISTOR UN2111	
		< RESISTOR >	
R901	1-216-041-00	METAL CHIP 470 5% 1/10W	
R902	1-216-041-00	METAL CHIP 470 5% 1/10W	
R933	1-216-059-00	METAL CHIP 2.7K 5% 1/10W	
R934	1-216-063-00	RES,CHIP 3.9K 5% 1/10W	
		< VARIABLE RESISTOR >	
RV901	1-225-616-11	RES, VAR, CARBON 20K (REC LEVEL)	
		< SWITCH >	
S933	1-554-303-21	SWITCH, TACTILE (FADER)	
S934	1-554-303-21	SWITCH, TACTILE (ARL)	
S935	1-554-303-21	SWITCH, TACTILE (CD SYNCHRO)	

		SW (A) BOARD (US,CND) (SUPPLIED WITH MAIN BOARD, COMPLETE) *****	
		< RESISTOR >	
R903	1-216-097-00	RES,CHIP 100K 5% 1/10W (WE825S:US)	
R947	1-216-089-00	RES,CHIP 47K 5% 1/10W	
		< VARIABLE RESISTOR >	
RV902	1-225-173-21	RES, VAR, CARBON 50K (PITCH CONTROL) (WE825S:US)	
		< SWITCH >	
S801	1-554-118-00	SWITCH, PUSH (1 KEY) (I/C)	
S947	1-762-609-11	SWITCH, SLIDE (DIRECTION MODE)	
S960	1-554-118-00	SWITCH, PUSH (1 KEY) (PITCH CONTROL) (WE825S:US)	

		SW (B) BOARD (EXCEPT US,CND) (SUPPLIED WITH MAIN BOARD, COMPLETE) *****	
		< RESISTOR >	
R903A	1-216-097-00	RES,CHIP 100K 5% 1/10W (AEP,UK)	
R947A	1-216-089-00	RES,CHIP 47K 5% 1/10W	
		< VARIABLE RESISTOR >	
RV902A	1-225-173-21	RES, VAR, CARBON 50K (PITCH CONTROL) (AEP,UK)	

Ref. No.	Part No.	Description	Remark
		< SWITCH >	
S947A	1-762-609-11	SWITCH, SLIDE (DIRECTION MODE)	
S960A	1-554-118-00	SWITCH, PUSH (1 KEY) (PITCH CONTROL) (AEP,UK)	

		SW (C) BOARD (EXCEPT US,CND) (SUPPLIED WITH MAIN BOARD, COMPLETE) *****	
		< CAPACITOR >	
△ C001	1-113-925-11	CERAMIC 0.01uF 20% 250V	
		< CONNECTOR >	
CN002	1-568-226-11	PIN, CONNECTOR 2P (AEP,UK,CH,AUS)	
* CN002	1-580-230-31	PIN, CONNECTOR (PC BOARD) 2P (SP,MY)	
		< SWITCH >	
△ S850	1-762-581-11	SWITCH, AC POWER PUSH (1 KEY) (Ⓢ)	

		TRANS (A) BOARD (EXCEPT SP,MY) (SUPPLIED WITH MAIN BOARD, COMPLETE) *****	
		< CONNECTOR >	
* CN001	1-573-047-11	PIN, CONNECTOR (PC BOARD) 2P	

		TRANS (B) BOARD (SUPPLIED WITH MAIN BOARD, COMPLETE) *****	
		< CAPACITOR >	
C751	1-165-319-11	CERAMIC CHIP 0.1uF 50V	
C752	1-137-374-11	FILM 0.047uF 5% 50V	
C753	1-137-374-11	FILM 0.047uF 5% 50V	
		< TRANSFORMER >	
△ T701	1-431-786-11	TRANSFORMER, POWER (AEP,UK,CH,AUS)	
△ T701	1-431-788-11	TRANSFORMER, POWER (US,CND)	
△ T701	1-431-789-11	TRANSFORMER, POWER (SP,MY)	

The components identified by mark △ or dotted line with mark. △ are critical for safety. Replace only with part number specified.	Les composants identifiés par une marque △ sont critiques pour la sécurité. Ne les remplacer que par une pièce portant le numéro spécifié.
---	--

TC-WE625/WE725/WE825S

Ref. No.	Part No.	Description	Remark
		MISCELLANEOUS *****	
52	1-590-486-11	WIRE (FLAT TYPE) (7 CORE) (WE625)	
52	1-769-914-11	WIRE (FLAT TYPE) (9 CORE) (WE725/WE825S)	
56	1-769-883-11	WIRE (FLAT TYPE) (7 CORE) (WE625)	
56	1-769-916-11	WIRE (FLAT TYPE) (9 CORE) (WE725/WE825S)	
△ 58	1-575-651-21	CORD, POWER (AEP,SP,MY)	
△ 59	1-751-529-11	CORD, POWER (UK)	
△ 60	1-590-926-11	CORD, POWER (US,CND)	
△ 61	1-696-845-11	CORD, POWER (AUS)	
△ 62	1-782-510-11	CORD, POWER (CH)	
162	1-769-598-11	WIRE (FLAT TYPE) (41 CORE)	
217	1-638-983-11	MOTOR FLEXIBLE BOARD	
HRPE101	A-2004-527-A	DECK ASSY, HEAD (RECORD/PLAYBACK/ERASE)	
M1	X-3365-377-2	MOTOR ASSY (CAPSTAN)	
M2	X-3363-501-2	MOTOR ASSY (REEL)	
△ S701	1-692-155-11	SELECTOR, POWER VOLTAGE (VOLTAGE) (SP,MY)	
△ T701	1-431-786-11	TRANSFORMER, POWER (AEP,UK,CH,AUS)	
△ T701	1-431-788-11	TRANSFORMER, POWER (US,CND)	
△ T701	1-431-789-11	TRANSFORMER, POWER (SP,MY)	

ACCESSORIES & PACKING MATERIALS *****			
	1-559-713-31	CORD, CONNECTION (AUDIO)	
	1-777-172-11	CORD, CONNECTION (CONTROL A1) (CND)	
*	3-023-344-01	INDIVIDUAL CARTON (WE725)	
*	3-023-369-01	INDIVIDUAL CARTON (WE625:US,CND,AUS)	
*	3-023-370-01	INDIVIDUAL CARTON (WE625:CH,SP,MY)	
*	3-023-373-01	CUSHION	
*	3-023-374-01	INDIVIDUAL CARTON (WE825S:AEP,UK)	
*	3-025-278-01	INDIVIDUAL CARTON (WE825S:US)	
	3-862-713-11	MANUAL, INSTRUCTION (ENGLISH) (US,CND,UK,CH,AUS)	
	3-862-713-21	MANUAL, INSTRUCTION (FRENCH) (CND)	
	3-862-713-31	MANUAL, INSTRUCTION (ENGLISH,FRENCH, SPANISH,PORTUGUESE) (AEP,SP,MY)	
	3-862-713-41	MANUAL, INSTRUCTION (GERMAN,DUTCH, SWEDISH,ITALIAN) (AEP)	
	3-862-713-51	MANUAL, INSTRUCTION (CHINESE) (CH,SP,MY)	

HARDWARE LIST *****			
#1	7-621-775-00	SCREW +B 2.6X3	
#2	7-685-871-01	SCREW +BVTT 3X6 (S)	
#3	7-685-646-79	SCREW +BVTP 3X8 TYPE2 N-S	
#4	7-685-862-09	SCREW +BVTT 2.6X6 (S)	
#5	7-685-134-19	SCREW +PTPWH 2.6X8 (TYPE2)	
#6	7-627-556-08	SCREW +P 2.6X2.8	

The components identified by mark △ or dotted line with mark △ are critical for safety. Replace only with part number specified.

Les composants identifiés par une marque △ sont critiques pour la sécurité. Ne les remplacer que par une pièce portant le numéro spécifié.