

TC-WA7ES/WR565/WR665S

SERVICE MANUAL

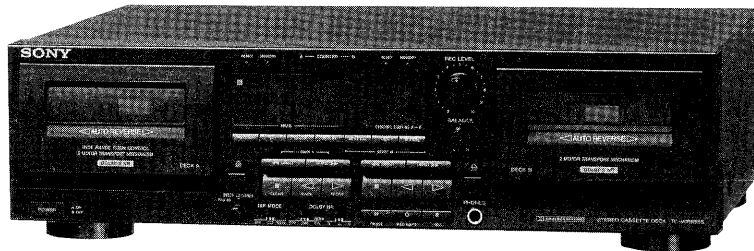

Photo : TC-WR665S

US Model
TC-WA7ES/WR565/WR665S

Canadian Model

AEP Model

UK Model

E Model

Australian Model

Chinese Model

TC-WR565/WR665S

* Dolby noise reduction and HX Pro headroom extension manufactured under license from Dolby Laboratories Licensing Corporation. HX Pro originated by Bang & Olufsen.

"DOLBY", the double-D symbol  and "HX PRO" are trademarks of Dolby Laboratories Licensing Corporation.

Model Name Using Similar Mechanism	TC-WR545/WR741	
Tape Transport Mechanism Type	DECK A	TC-WR565/WR665S : TCM-190RA14CL TC-WA7ES : TCM-190RA12CL
	DECK B	TCM-190RB12CL

SPECIFICATIONS

System

Recording system

4-track 2-channel stereo

Fast-winding time (approx.)

90 sec. (with Sony C-60 cassette)

Bias AC bias

Signal-to-noise ratio (at peak level and weighted with Dolby NR off)

Type I tape, Sony Type I (NORMAL) : 55 dB

Type II tape, Sony Type II (HIGH) : 57 dB

Type IV tape, Sony Type IV (METAL) : 58 dB

S/N ratio improvement (approximate values)

With Dolby B NR on : 5dB at 1kHz, 10dB at 5kHz

With Dolby C NR on : 15dB at 500Hz, 20dB at 1kHz

With Dolby S NR on (TC-WA7ES/WR665S only) :

10dB at 100Hz, 24dB at 1kHz

Harmonic distortion

0.4% (with Type I tape, Sony Type I (NORMAL) :
160 nWb/m 315 Hz, 3rd H.D.)

1.8% (with Type IV tape, Sony Type IV (METAL) :
250 nWb/m 315 Hz, 3rd H.D.)

Frequency response (Dolby NR off)

Type I tape, Sony Type I (NORMAL) :
30-15,000Hz (± 3dB, IEC)

Type II tape, Sony Type II (HIGH) :
30-17,000Hz (± 3dB, IEC)

Type IV tape, Sony Type IV (METAL) :
30-18,000Hz (± 3dB, IEC)
30-13,000Hz (± 3dB, - 4dB recording)

Wow and flutter

TC-WA7ES/WR665S : ± 0.13% W. Peak (IEC)

0.07% W. RMS (NAB)

± 0.18% W. Peak (DIN)

TC-WR565 : ± 0.14% W. Peak (IEC)

0.08% W. RMS (NAB)

± 0.19% W. Peak (DIN)

Variable pitch range (approx.)

- 30 to +30%

Inputs

Line inputs (phono jacks)

Sensitivity : 0.16V

Input impedance : 47 kilohms

Outputs

Line outputs (phono jacks)

Rated output level : 0.5V at a load impedance of
47 kilohms

Load impedance : Over 10 kilohms

Headphones (stereo phone jack)

Output level : 1mW at a load impedance of 32 ohms

- Continued on page 2 -

STEREO CASSETTE DECK
SONY®

General

Power requirements

Where purchased	Power requirements
US, Canadian model	120V AC, 60Hz
AEP, UK, German, Chinese model	220 - 230V AC, 50/60Hz
Australian model	240V AC, 50/60Hz
E model	120/220/240V AC, 50/60Hz

Power consumption

26W

Dimensions (approx) (w/h/d)

Model for U.K. and Australian :

430×123 ×300mm (w/h/d)

(17 × 4 7/8 × 11 7/8 inches)

Model for other countries :

430×123 ×290mm (w/h/d)

(17 × 4 7/8 × 11 1/2 inches)

including projecting parts and controls

Mass (Approx.)

4.5kg (9lbs 15oz)

Supplied accessories

Audio connecting cords (2 phono plug-2 phone plugs) (2)

Optional accessory

Remote commander RM-J902

Design and specifications are subject to change without notice.

TABLE OF CONTENTS

Section	Title	Page
Specifications	1
Safety Check-out	3
1. GENERAL		
1-1. Identifying the Parts	4
2. DISASSEMBLY		
2-1. Front Panel	5
2-2. Mechanism Deck	5
2-3. Capstan Motor, Reel Motor	6
2-4. Head, Pinch Roller	6
3. ADJUSTMENTS		
3-1. Mechanical Adjustments	7
3-2. Electrical Adjustments	7
4. EXPLANATION OF IC TERMINALS	11
5. DIAGRAMS		
5-1. Block Diagram	13
5-2. Printed Wiring Boards (System Control Section)	17
5-3. Schematic Diagram (System Control Section)	21
5-4. Schematic Diagram (Audio Section)	27
5-5. Printed Wiring Boards (Audio Section)	31
5-6. Printed Wiring Boards (Dolby (S) Section)	34
5-7. Schematic Diagram (Dolby (S) Section)	34
6. EXPLODED VIEWS		
6-1. Chassis Section	37
6-2. Front Panel Section	39
6-3. Mechanism Section 1	40
6-4. Mechanism Section 2	41
7. ELECTRICAL PARTS LIST	42

MODEL IDENTIFICATION
(Specification Label)

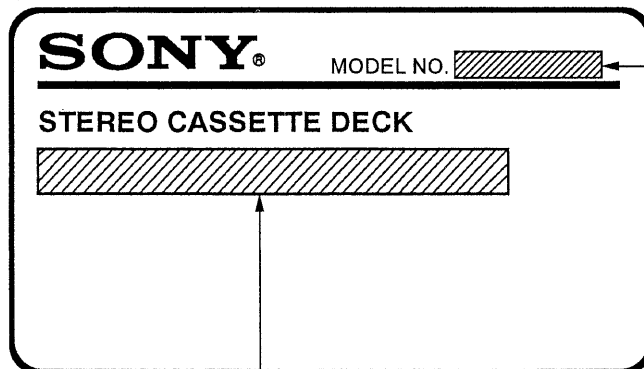

TC-WR565
TC-WR665S
TC-WA7ES

US, Canadian model : AC 120V 60Hz
UK model : AC 240V 50Hz
Australian model : AC 240V~50/60Hz
AEP, German model : AC 220-230V~50/60Hz
E model : AC120, 220, 240V~50/60Hz
Chinese model : AC 220 - 230V~50/60Hz

SAFETY CHECK-OUT

After correcting the original service problem, perform the following safety check before releasing the set to the customer:

Check the antenna terminals, metal trim, "metallized" knobs, screws, and all other exposed metal parts for AC leakage. Check leakage as described below.

LEAKAGE TEST

The AC leakage from any exposed metal part to earth ground and from all exposed metal parts to any exposed metal part having a return to chassis, must not exceed 0.5 mA (500 microamperes). Leakage current can be measured by any one of three methods.

1. A commercial leakage tester, such as the Simpson 229 or RCA WT-540A. Follow the manufacturers' instructions to use these instruments.
2. A battery-operated AC milliammeter. The Data Precision 245 digital multimeter is suitable for this job.
3. Measuring the voltage drop across a resistor by means of a VOM or battery-operated AC voltmeter. The "limit" indication is 0.75 V, so analog meters must have an accurate low-voltage scale. The Simpson 250 and Sanwa SH-63Trd are examples of a passive VOM that is suitable. Nearly all battery operated digital multimeters that have a 2V AC range are suitable. (See Fig. A)

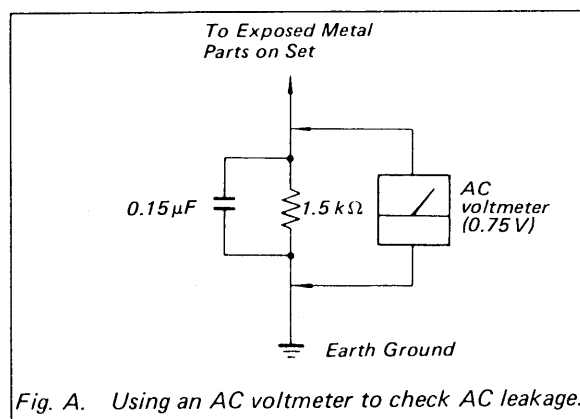





Fig. A. Using an AC voltmeter to check AC leakage.

SAFETY-RELATED COMPONENT WARNING!!

COMPONENTS IDENTIFIED BY MARK  OR DOTTED LINE WITH MARK  ON THE SCHEMATIC DIAGRAMS AND IN THE PARTS LIST ARE CRITICAL TO SAFE OPERATION. REPLACE THESE COMPONENTS WITH SONY PARTS WHOSE PART NUMBERS APPEAR AS SHOWN IN THIS MANUAL OR IN SUPPLEMENTS PUBLISHED BY SONY.

ATTENTION AU COMPOSANT AYANT RAPPORT À LA SÉCURITÉ!

LES COMPOSANTS IDENTIFIÉS PAR UNE MARQUE  SUR LES DIAGRAMMES SCHÉMATIQUES ET LA LISTE DES PIÈCES SONT CRITIQUES POUR LA SÉCURITÉ DE FONCTIONNEMENT. NE REMPLACER CES COMPOSANTS QUE PAR DES PIÈCES SONY DONT LES NUMÉROS SONT DONNÉS DANS CE MANUEL OU DANS LES SUPPLÉMENTS PUBLIÉS PAR SONY.

SECTION 1 GENERAL

1-1. IDENTIFYING THE PARTS

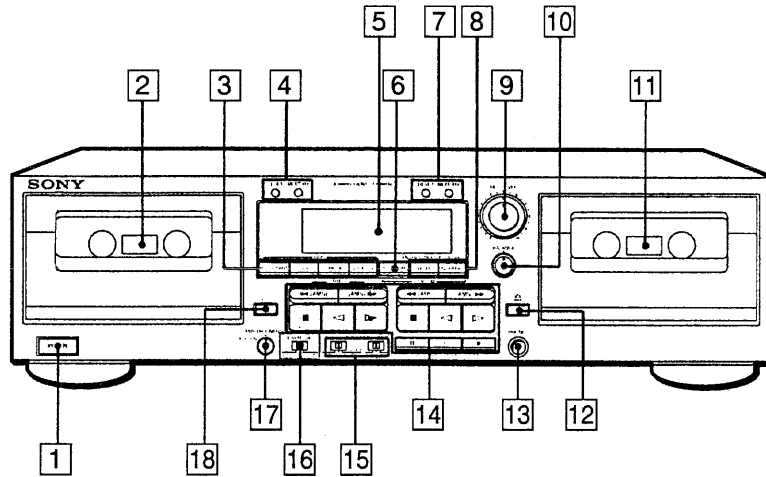

FRONT PANEL

- | | |
|---|--|
| <p>1 POWER switch</p> <p>2 Deck A</p> <p>3 RMS**operation buttons
RMS/START buttons
SET buttons
CHECK buttons
DISPLAY buttons</p> <p>4 COUNTER buttons (deck A)
RESET button
MEMORY button (TC-WA7ES/WR665S only)</p> <p>5 Display panel</p> <p>6 AUTO CAL button</p> <p>7 COUNTER buttons (deck B)
RESET button
MEMORY button (TC-WA7ES/WR665S only)</p> <p>8 SYNCHRO DUBBING buttons
HIGH button
NORMAL button</p> <p>9 REC (recording) LEVEL control</p> <p>10 BALANCE control</p> | <p>11 Deck B</p> <p>12 (eject) button (deck B)</p> <p>13 PHONES jack (stereo phone jack)</p> <p>14 Tape operation buttons
◀◀ (leftward fastwinding)/AMS***/
RMS** - button
▶▶ (rightward fastwinding)/AMS***/
RMS** +button
■ (stop)/(RMS**) CLEAR button
◀ (reverse play)/(RMS**) BACK
button
▶ (forward play)/(RMS**) FRONT
button
 PAUSE button
○ REC MUTE (record muting) button
● REC (record muting) button</p> <p>15 DOLBY NR switches
OFF/ON/FILTER ON switch
B/C/S switch</p> <p>16 DIR (direction) MODE switch</p> <p>17 PITCH control</p> <p>18 (eject) button (deck A)</p> |
|---|--|

**Random Music Sensor
***Automatic Music Sensor

SECTION 2 DISASSEMBLY

Note : Follow the disassembly procedure in the numerical order given.

CASE
Unscrew the four case attachment screws M3 × 8 and remove the case.

2-1. FRONT PANEL

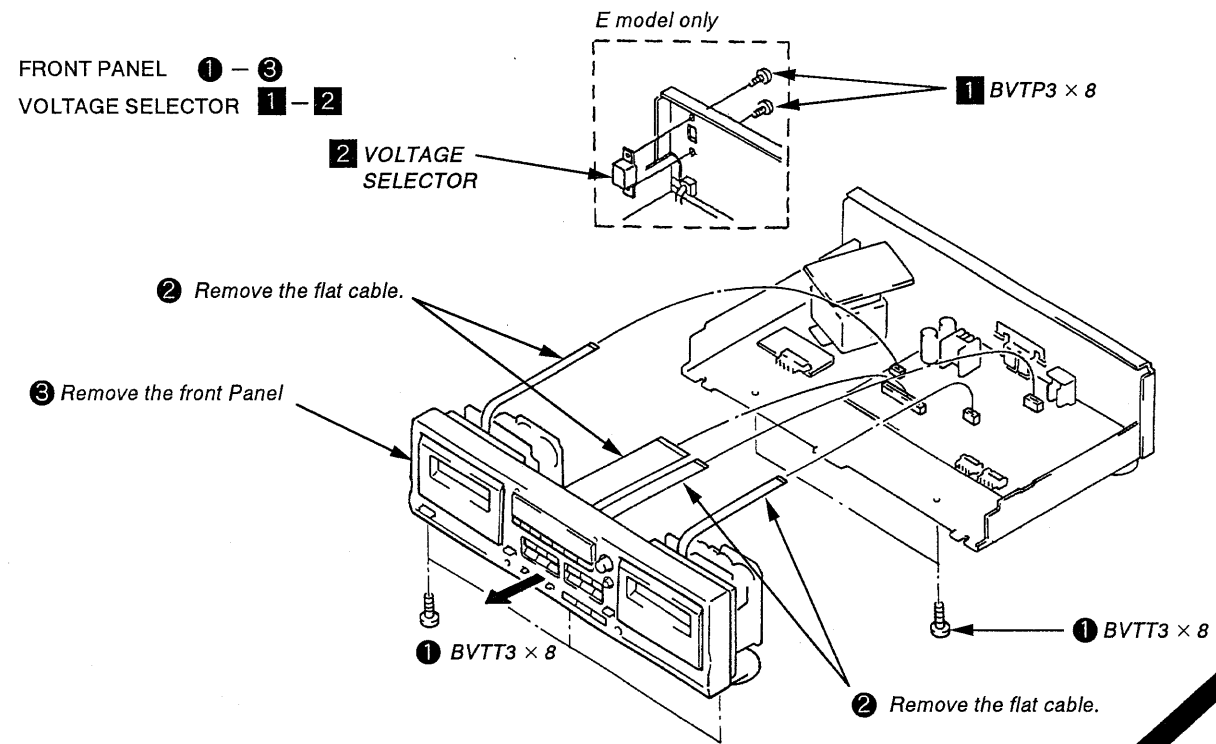

2-2. MECHANISM DECK

① Press the EJECT button.

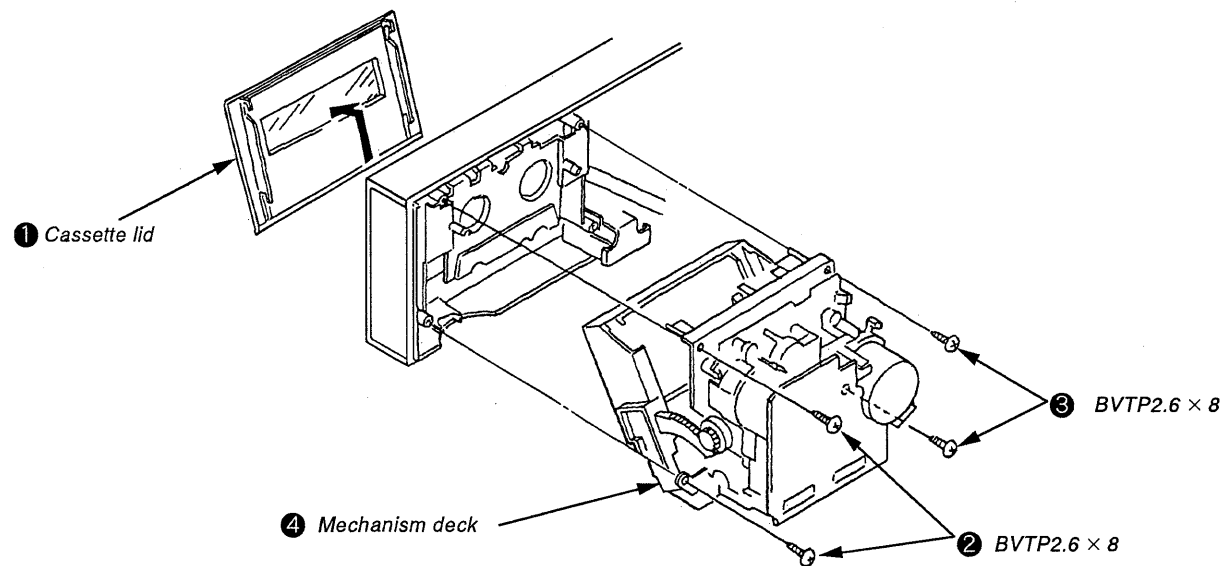

2-3. CAPSTAN MOTOR, REEL MOTOR

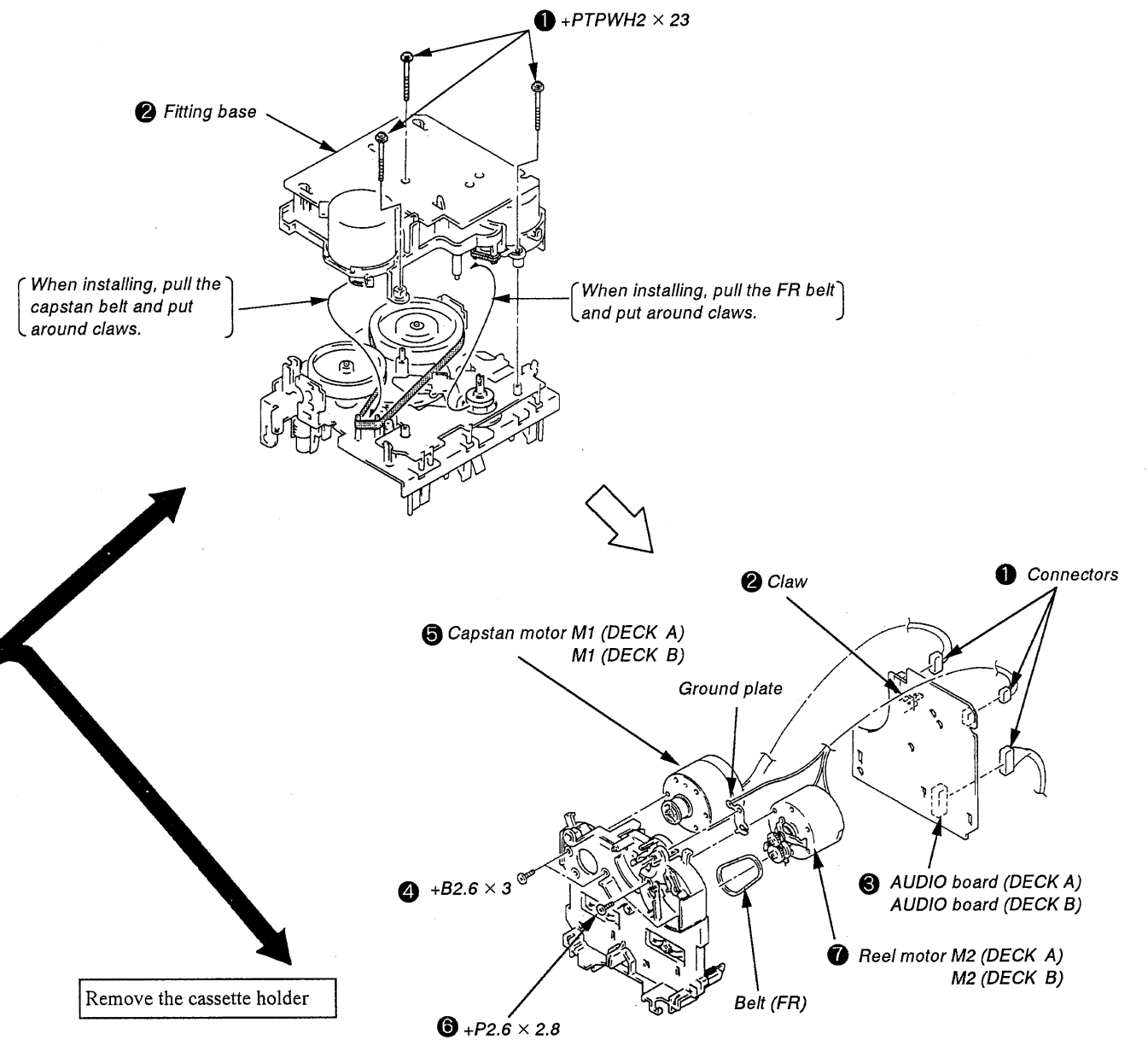

2-4. HEAD, PINCH ROLLER

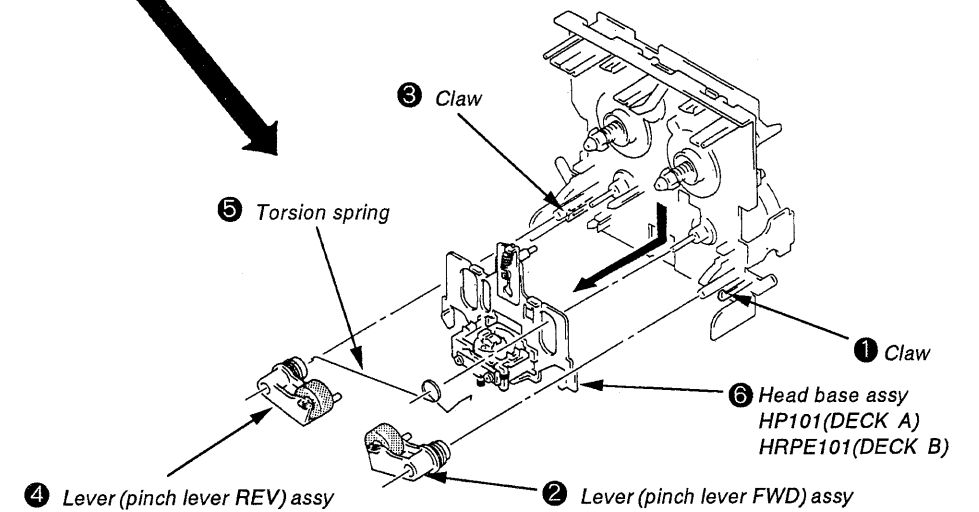

SECTION 3 ADJUSTMENTS

3-1. MECHANICAL ADJUSTMENTS

PRECAUTION

1. Clean the following parts with a denatured alcohol-moistened swab:

record/playback/erase head	pinch roller
rubber belts	capstan
idlers	
2. Demagnetize the record/playback head with a head demagnetizer.
3. Do not use a magnetized screwdriver for the adjustment.
4. After the adjustments, apply suitable locking compound to the parts adjusted.
5. The adjustments should be performed with the rated power supply voltage unless otherwise noted.

Torque Measurement

Torque	Torque meter	Meter reading
Forward	CQ-102C	30 to 65g • cm (0.42 to 0.9 oz • inch)
Forward back tension	CQ-102C	DECK A : 1 to 6g • cm (0.014 to 0.083 oz • inch) DECK B : 2 to 9g • cm (0.03 to 0.12 oz • inch)
Reverse	CQ-102RC	30 to 65g • cm (0.42 to 0.9 oz • inch)
Reverse back tension	CQ-102RC	1 to 6g • cm (0.014 to 0.083 oz • inch)
FF/REW	CQ-201B	70 to 120g•cm (0.98 to 1.66 oz•inch)

3-2. ELECTRICAL ADJUSTMENTS

PRECAUTION

1. The adjustment should be performed in the publication.
(Be sure to make playback adjustment at first.)
2. The adjustments and measurement should be performed for both L-CH and R-CH.
 - Switch position

DOLBY NR switch	: OFF
DIR MODE switch	: ⇄
 - Standard record position :
Deliver the standard input signal level to input jack and set the REC LEVEL control to obtain the standard output signal level as follows.

— Record Mode —

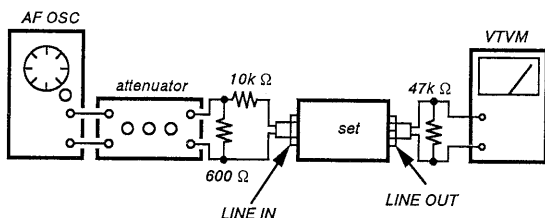

Standard Input Level

Input terminal	LINE IN
source impedance	10k Ω
input signal level	0.5V (- 3.8dB)

Standard Output Level

Output terminal	LINE OUT
load impedance	47k Ω
output signal level	0.5V (- 3.8dB)

Test Tape

Tape	Contents	Use
P-4-A100	10kHz, - 10dB	Azimuth Adjustment
P-4-L300	315Hz, 0dB	PB Level Adjustment
WS-48B	3kHz, 0dB	Tape Speed Adjustment

0dB=0.775V

Test Mode

1. Insert a short-circuit plug into TP801 (2P) and turn ON the power switch.
At first, all the fluorescent tubes light up, then the system returns to normal display. (However, "0000" is not displayed on the counter.)
2. To release the test mode, remove the short plug and turn off the power switch.
3. Remove the short plug after completion of adjustment.

Record/Playback Head Azimuth Adjustment Procedure :

1. Forward playback Mode

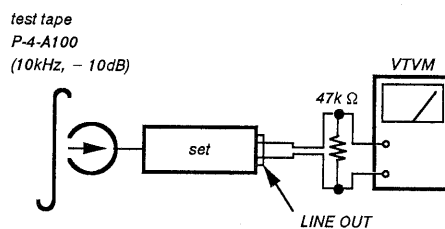

2. Turn the adjustment screw for the maximum output levels. If these levels do not match, turn the adjustment screw until both of output levels match together within 1dB.

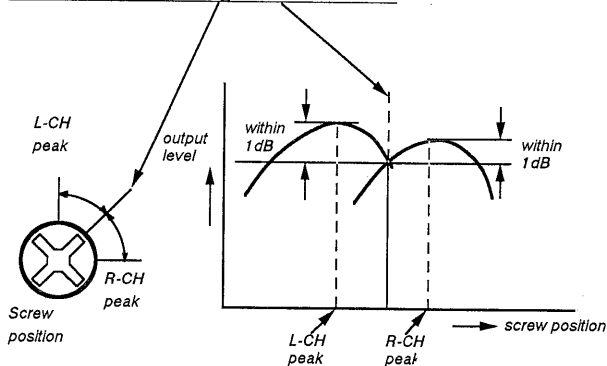

3. Playback Mode

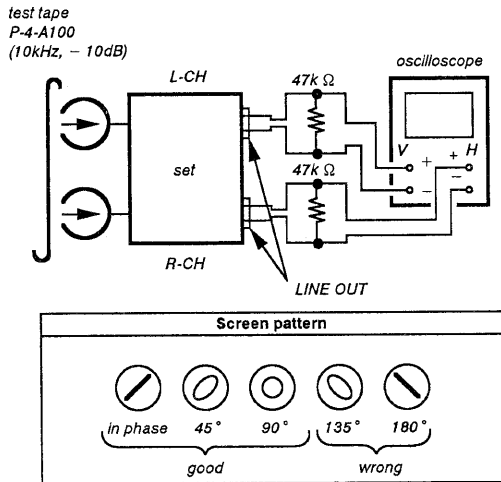

4. Change the reverse playback mode and repeat the steps 1 to 3.
5. After the adjustment, lock the adjustment screws with suitable locking compound.

Adjustment Location : – record/playback head –

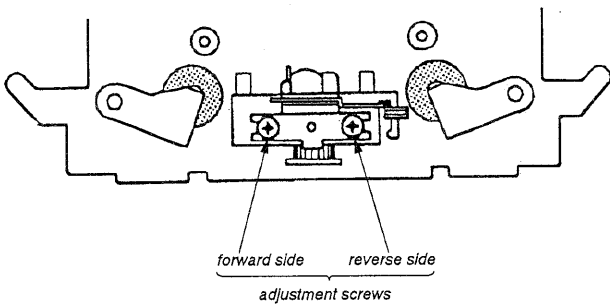

Tape Speed Adjustment

Procedure :

– Forward Playback Mode –

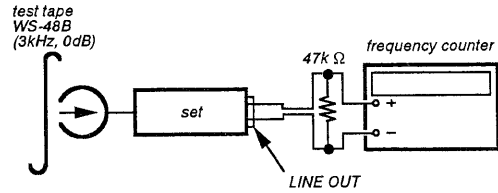

(High speed adjustment)

1. Set to test mode. (Refer to page 7)
2. Set to FWD playback mode.
3. Keep on pressing the HIGH SPEED DUBBING switch.
4. Adjust RV72 so that the frequency counter reading becomes $6,000 \pm 20\text{Hz}$.
5. Release test mode after adjustment is completed.

(Normal speed adjustment)

1. Set to FWD playback mode.
2. Adjust RV71 so that the frequency counter reading becomes $3,000 \pm 10\text{Hz}$.

(Pitch control adjustment) (TC-WR565, TC-WR665S)

1. Turn ON the PITCH CONTROL switch.
2. Set RV801 to mechanical center.
3. Set to FWD playback mode.
4. Adjust RV802 so that the frequency counter reading becomes $3,000 \pm 10\text{Hz}$.

Frequency difference between the beginning and the end of the tape should be within 3%.

Frequency difference between the deck A and deck B the beginning of the tape should be within 1.5%.

Adjustment Location : AUDIO board, CONNECTOR board.
(See page 10)

Playback Level Adjustment

Procedure :

– Forward Playback Mode –

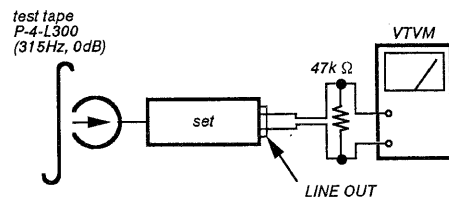

Adjust RV11(L-CH) and RV21(R-CH) so the VTVM reading becomes the adjustment limits below.

Adjustment Value :

LINE OUT level : – $7.7 \pm 0.5\text{dB}$ (0.301 to 0.338V)

Level difference between channels : within 0.5dB

Confirm the LINE OUT level does not change in playback mode while changing the mode from playback to stop several times.

Adjustment Location : AUDIO board. (See page 10)

Bias Consumption Current Adjustment

This adjustment should be performed when replacing the head assy or the bias oscillating transformer (T81, T91).

Procedure :

() : R-CH

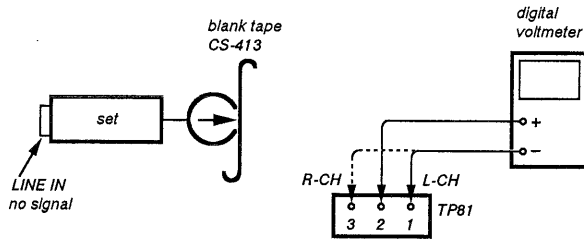

1. Connect the digital voltmeter to test point TP81.
2. Set RV81 (RV91) to mechanical center.
3. Set to FWD record mode.
4. Adjust T81 (T91) so that the digital voltmeter reading becomes minimum.

Adjustment Value : Maximum 220mV

Adjustment Location : AUDIO board. (See page 10)

Record Bias Adjustment

Setting :

REC LEVEL control : standard record position (Refer to page 7.)

Procedure :

1. Record Mode

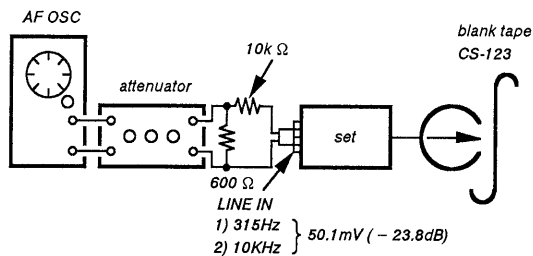

2. Playback Mode

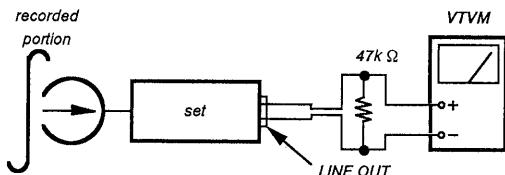

Confirm that the 10kHz playback output is $0 \pm 0.5\text{dB}$ relative to the 315Hz output. If necessary, adjust RV81 (L-CH), RV91(R-CH) and repeat the steps given above.

Adjustment Location : AUDIO board. (See page 10)

Record Level Adjustment

Setting :

REC LEVEL control : standard record position (Refer to page 7.)

Procedure :

1. Record Mode

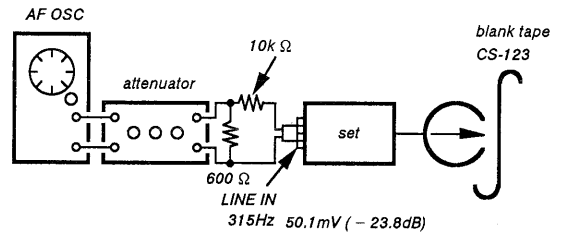

2. Playback Mode

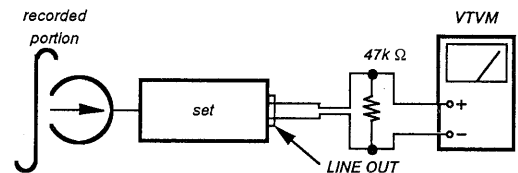

Confirm playback the tape recorded become adjustment level as follows.

If necessary, adjust RV101(L-CH), RV201(R-CH) and repeat the steps 1 and 2.

Adjustment Value :

LINE OUT level : $-23.8 \pm 0.5\text{dB}$ (47.2 to 53mV)

Adjustment Location : SYSTEM CONTROL board.

(See page 10)

— Adjustment Parts Location Diagrams —

[SYSTEM CONTROL BOARD]

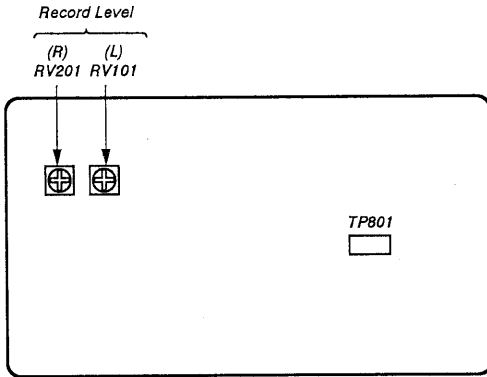

DECK-A :
[AUDIO BOARD]

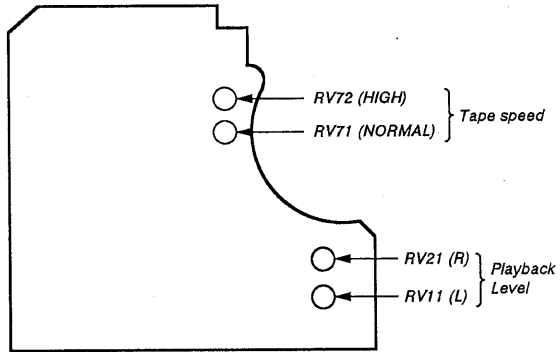

DECK-B :
[AUDIO BOARD]

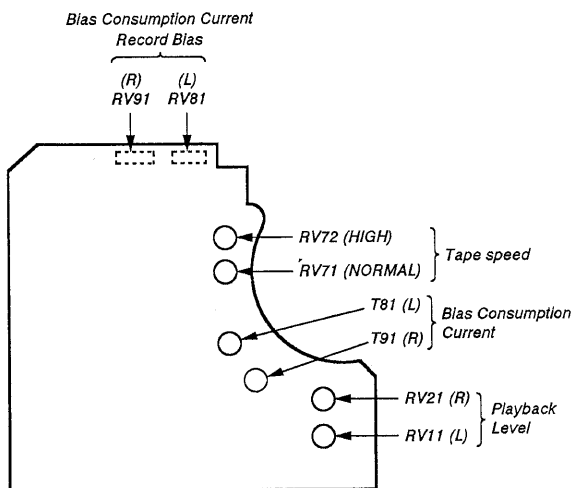

DECK-B :
[CONNECTOR BOARD]

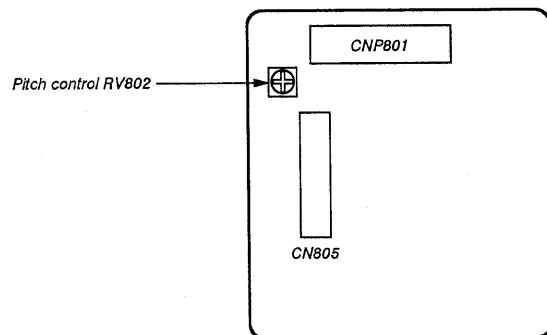

SECTION 4 EXPLANATION OF IC TERMINALS

IC801 CXP82316-053Q

Pin No.	Pin name	I/O	Description
1	$\overline{\text{TEST}}$	I	Test mode terminal. "L" : Test mode, "H" : Normal mode
2	SIRCS	I	Sircs signal in terminal.
3	POWER IN	I	Power OFF. OFF = 0V
4	SPEED H/L	O	Normal/High selector for equalizer.
5	A/B	O	Playback A/B selector. "L" : DECK-A, "H" : DECK-B
6	NR1	O	Dolby NR control.
7	NR0	O	Dolby NR control.
8	MODE0	O	Dolby NR mode control.
9	MODE1	O	Dolby NR mode control.
10	$\overline{\text{BC/S}}$	O	Dolby NR type selector. "L" : Dolby B, C, "H" : Dolby S
11	$\overline{\text{LIN MUTE}}$	O	Line mute ON/OFF. "L" : ON
12	$\overline{\text{IC MUTE}}$	O	Meter mute. "H" : ON
13	REALY REC/PB	O	Recording/Playback selector at DECK-B. "L" : Recording
14	REC CAL0	O	Recording calibration. "H" : ON
15	REC CAL1	O	Recording calibration. "H" : ON
16	EQ CAL0	O	EQ calibration terminal.
17	EQ CAL1	O	EQ calibration terminal.
18	BIAS	O	Bias ON/OFF at DECK-B. "H" : ON
19	POWER OUT	O	Power ON/OFF.
20	METAL (B)	I	Metal tape selector terminal. "H" : Metal
21	70 μ (B)	I	CrO ₂ tape selector terminal. "L" : CrO ₂
22	A/D CTRL0	O	A/D converter analog switch control.
23	A/D CTRL1	O	A/D converter analog switch control.
24	A/D IN0	I	A/D converter analog input.
25	A/D IN1	I	A/D converter analog input.
26	S. REEL (A)	I	S-Side reel rotation detection at DECK-A.
27	S. REEL (B)	I	S-Side reel rotation detection at DECK-B.
28	AMS IN	I	AMS signal input terminal.
29	AMS/ $\overline{\text{BS}}$	O	AMS/BS selector. "L" : BS ON
30	$\overline{\text{RESET}}$	I	Reset terminal. Reset : 0V
31	EXTAL	O	System clock output terminal.
32	XTAL	I	System clock input terminal.
33	V _{ss}	—	Power supply (GND)
34	BIAS CAL0	O	EQ Bias calibration terminal.
35	BAIS CAL1	O	EQ Bias calibration terminal.
36	BAIS CAL2	O	EQ Bias calibration terminal.
37	BAIS CAL3	O	EQ Bias calibration terminal.
38	$\overline{\text{REC MUTE}}$	O	Recording mute ON/OFF. "L" : ON
39	OSC ON/OFF	O	OSC ON/OFF control. "H" : OFF
40	OSC H/L	O	OSC H/L control terminal.

Pin No.	Pin name	I/O	Description
41	CAP. MOTOR (B)	O	Capstan motor output at DECK-B.
42	CAP. MOTOR (A)	O	Capstan motor output at DECK-A.
43	CAP. MOT (L/ \overline{H})	O	Capstan motor speed selector . "L" : Normal
44	PITCH. C. ON/ \overline{OFF}	O	Pitch control ON/OFF.
45	P16	O	VFD Segment.
46	P15	O	VFD Segment.
47	P14	O	VFD Segment.
48	P13	O	VFD Segment.
49	P12	O	VFD Segment.
50	P11	O	VFD Segment.
51	P10	O	VFD Segment.
52	P9	O	VFD Segment.
53	P8	O	VFD Segment.
54	P7	O	VFD Segment.
55	P6	O	VFD Segment.
56	P5	O	VFD Segment.
57	P4	O	VFD Segment.
58	P3	O	VFD Segment.
59	P2	O	VFD Segment.
60	P1	O	VFD Segment.
61	T0	O	VFD Grid.
62	T1	O	VFD Grid.
63	T2	O	VFD Grid.
64	T3	O	VFD Grid.
65	T4	O	VFD Grid.
66	T5	O	VFD Grid.
67	T6	O	VFD Grid.
68	T7	O	VFD Grid.
69	T8	O	VFD Grid.
70	T9	O	VFD Grid.
71	VFDP	—	VFD Power.
72	V _{DD}	—	Power supply (+5V)
73	—	—	+5V
74	REEL (A) +	O	Reel motor (+) output at DECK-A. "H" : FF.
75	REEL (A) —	O	Reel motor (—) output at DECK-A. "H" : REW.
76	REEL (B) +	O	Reel motor (+) output at DECK-B. "H" : FF.
77	REEL (B) —	O	Reel motor (—) output at DECK-B. "H" : REW.
78	STOP SW (A)	I	Mechanism stop switch input for DECK-A.
79	STOP SW (B)	I	Mechanism stop switch input for DECK-B.
80	HALF (A)	I	Half pawl input for DECK-A. "L" : Available

SECTION 5 DIAGRAMS

5-1. BLOCK DIAGRAM

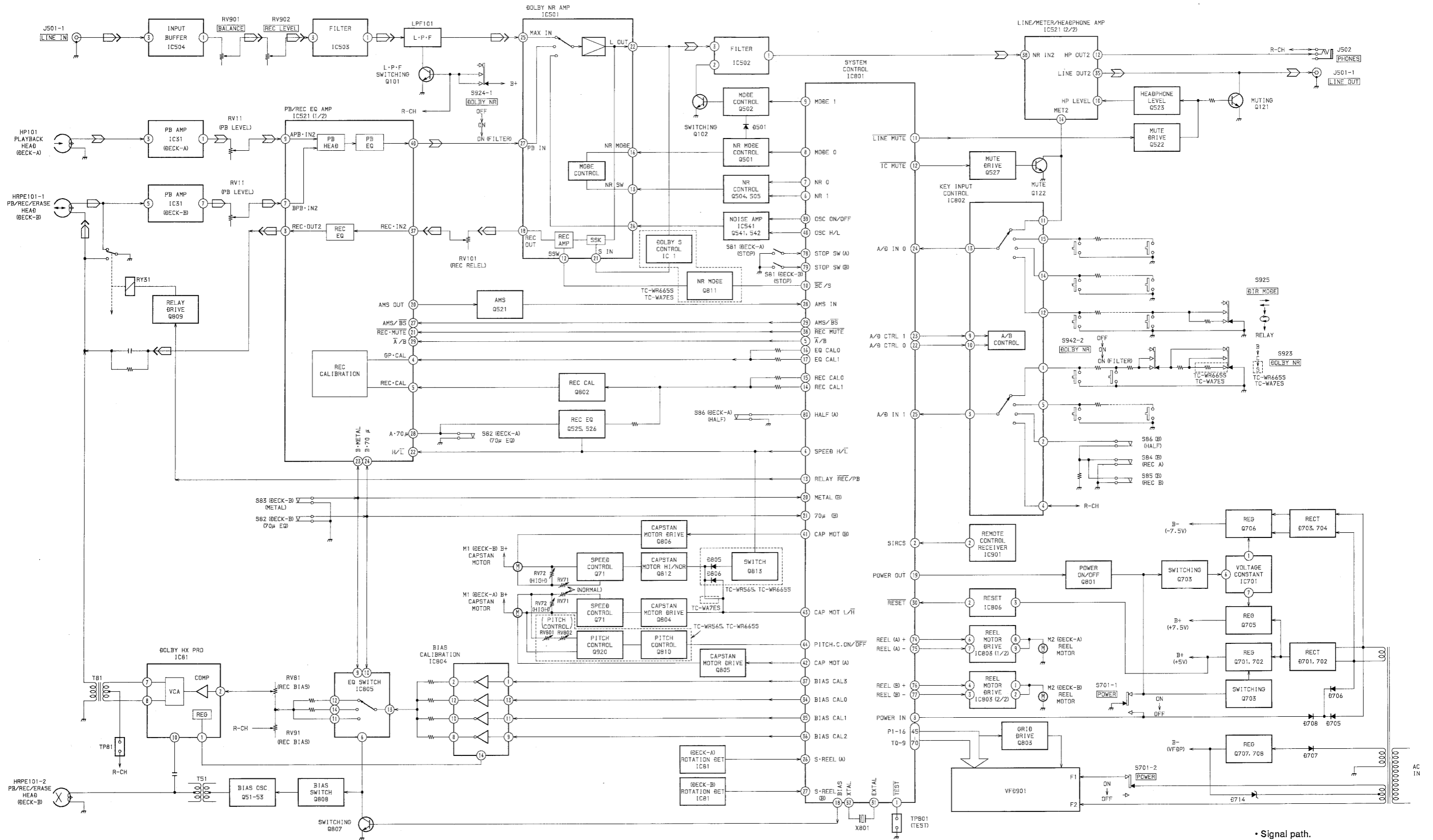

02 — R-CH is Omitted; Same as L-CH —

• Signal path.
 : PB (DECK A)
 : PB (DECK B)
 : REC (DECK B)

● **CIRCUIT BOARDS LOCATION**

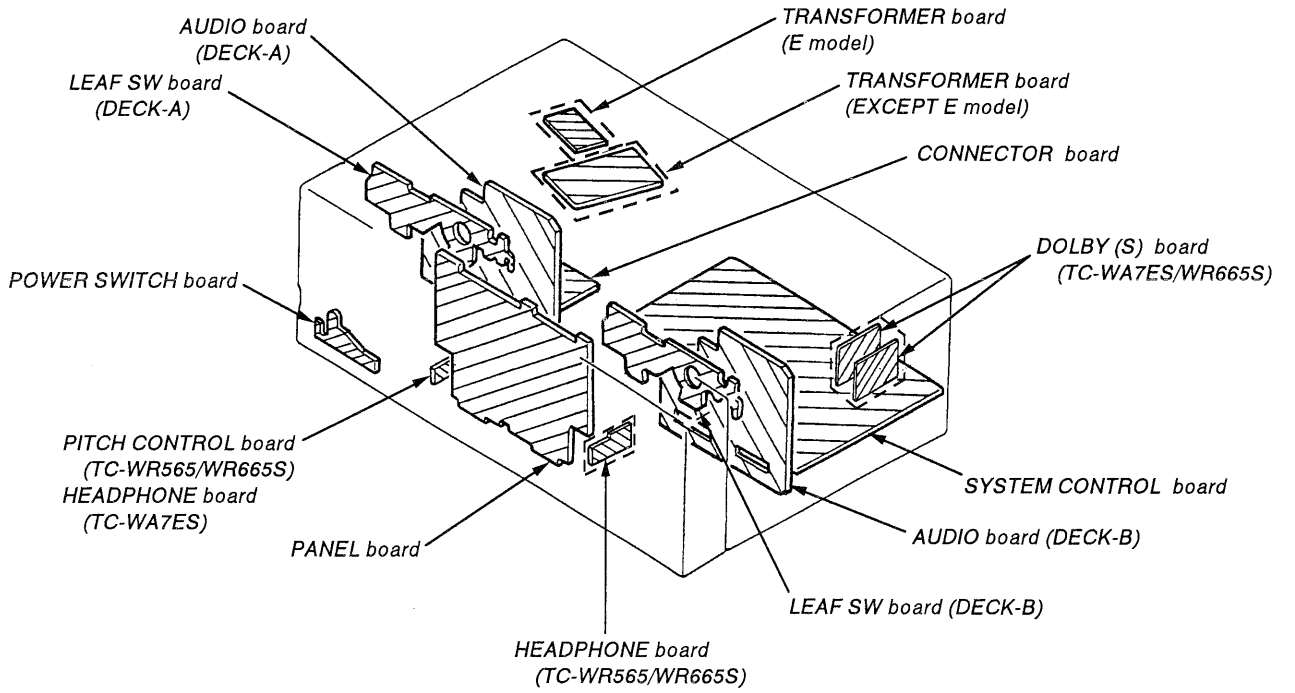

● SEMICONDUCTOR LEAD LAYOUTS

CXA1417Q
CXA1599Q

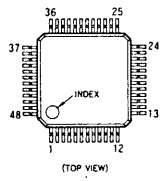

M5218AL

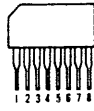

μ PC4570G2

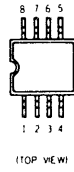

2SA1175-HFE

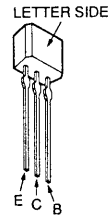

HZS6A1L
UZL-7L2
1SS202-1
11ES2-NTA2B

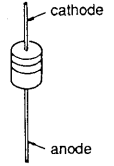

CXA1563S

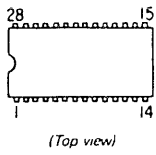

M5218AP

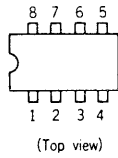

μ PC1297CA

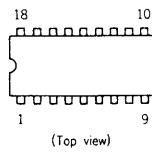

2SB1094-LK
2SD2012

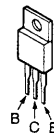

MA110

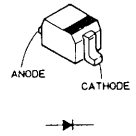

CXP82316-053Q

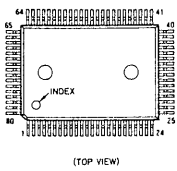

PST600E-T

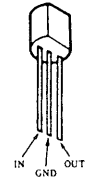

DTA144ES
DTC143TS
2SC2603-EF
2SD2144S

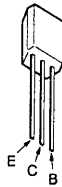

2SB1116A-L
2SD1387



NJL5165K-B (H1)

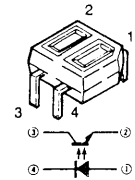

SBX1610-59

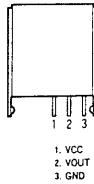

LA6510

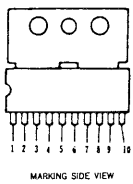

2SA1162-G

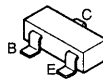

2SD1622-S

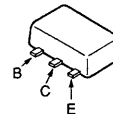

1N4148M

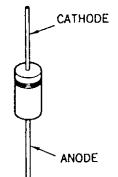

• SEMICONDUCTOR LOCATION

Ref. No.	Location	Ref. No.	Location
D121	D-7	Q101	D-4
D221	E-7	Q102	E-3
D501	E-4	Q121	B-5
D502	E-4	Q122	D-7
D503	C-2	Q201	D-2
D504	C-2	Q202	E-2
D505	C-4	Q221	B-5
D506	C-3	Q222	E-7
D521	E-7	Q501	E-4
D531	C-5	Q502	D-4
D541	B-2	Q503	E-4
D542	B-2	Q504	E-4
D701	B-10	Q505	E-4
D702	B-10	Q521	E-7
D703	B-10	Q522	F-4
D704	C-10	Q523	G-4
D705	B-10	Q525	E-10
D706	B-10	Q526	E-10
D707	C-10	Q527	E-7
D708	B-11	Q541	B-2
D709	B-9	Q542	B-2
D710	B-6	Q701	B-8
D711	C-8	Q702	B-8
D712	C-9	Q703	B-9
D713	C-10	Q704	B-6
D714	C-11	Q705	B-7
D715	C-9	Q706	C-8
D801	F-10	Q707	C-10
D802	F-10	Q708	C-11
D803	F-10	Q801	D-11
D804	F-10	Q802	D-10
D805	H-8	Q803	G-10
D806	H-11	Q804	H-10
D807	D-10	Q805	H-10
		Q806	H-9
IC501	D-3	Q807	E-5
IC502	E-3	Q808	E-5
IC503	D-5	Q809	G-4
IC504	B-3	Q810	H-9
IC521	G-3	Q811	D-7
IC541	B-2	Q812	H-8
IC701	C-7	Q813	H-8
IC801	E-10	Q920	F-21
IC802	F-8		
IC803	G-6		
IC804	D-5		
IC805	E-5		
IC806	E-9		
IC901	F-18		

Note:
 ○ : parts extracted from the component side.
 □ : Pattern on the side which is seen.
 • Abbreviation
 CND : Canadian
 G : German
 AUS : Australian
 CH : Chinese

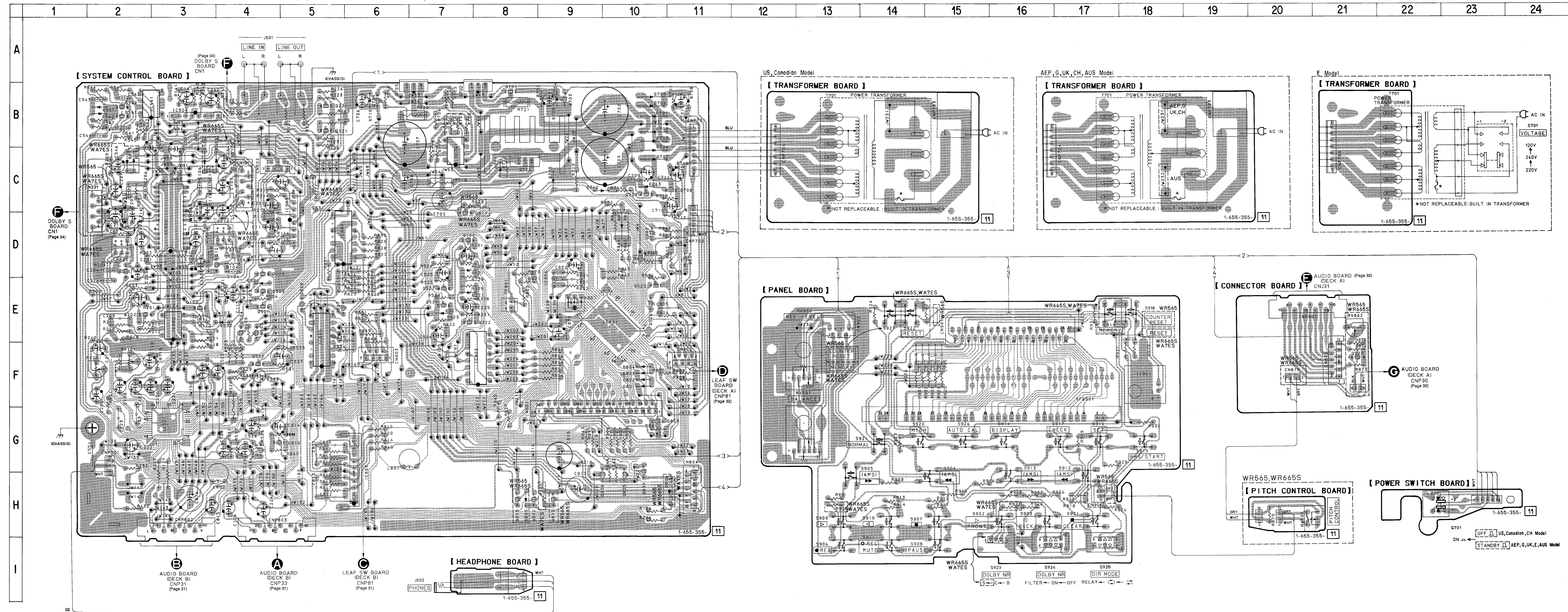

5-3. SCHEMATIC DIAGRAM (SYSTEM CONTROL SECTION) Refer to page 36 for IC Block Diagrams.

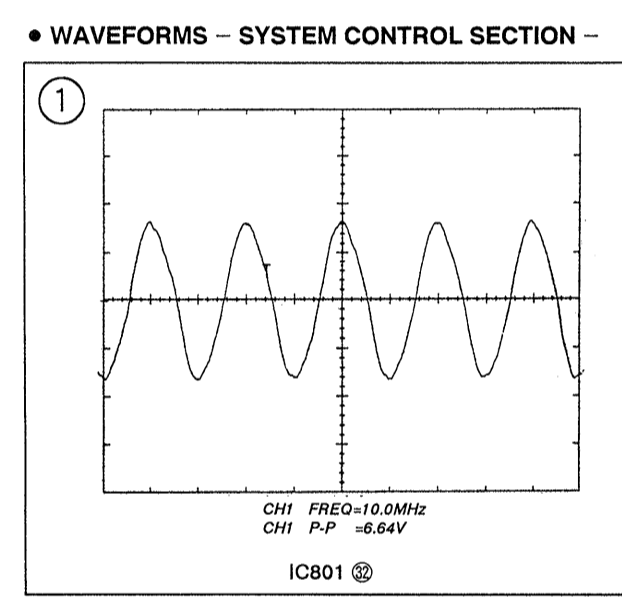
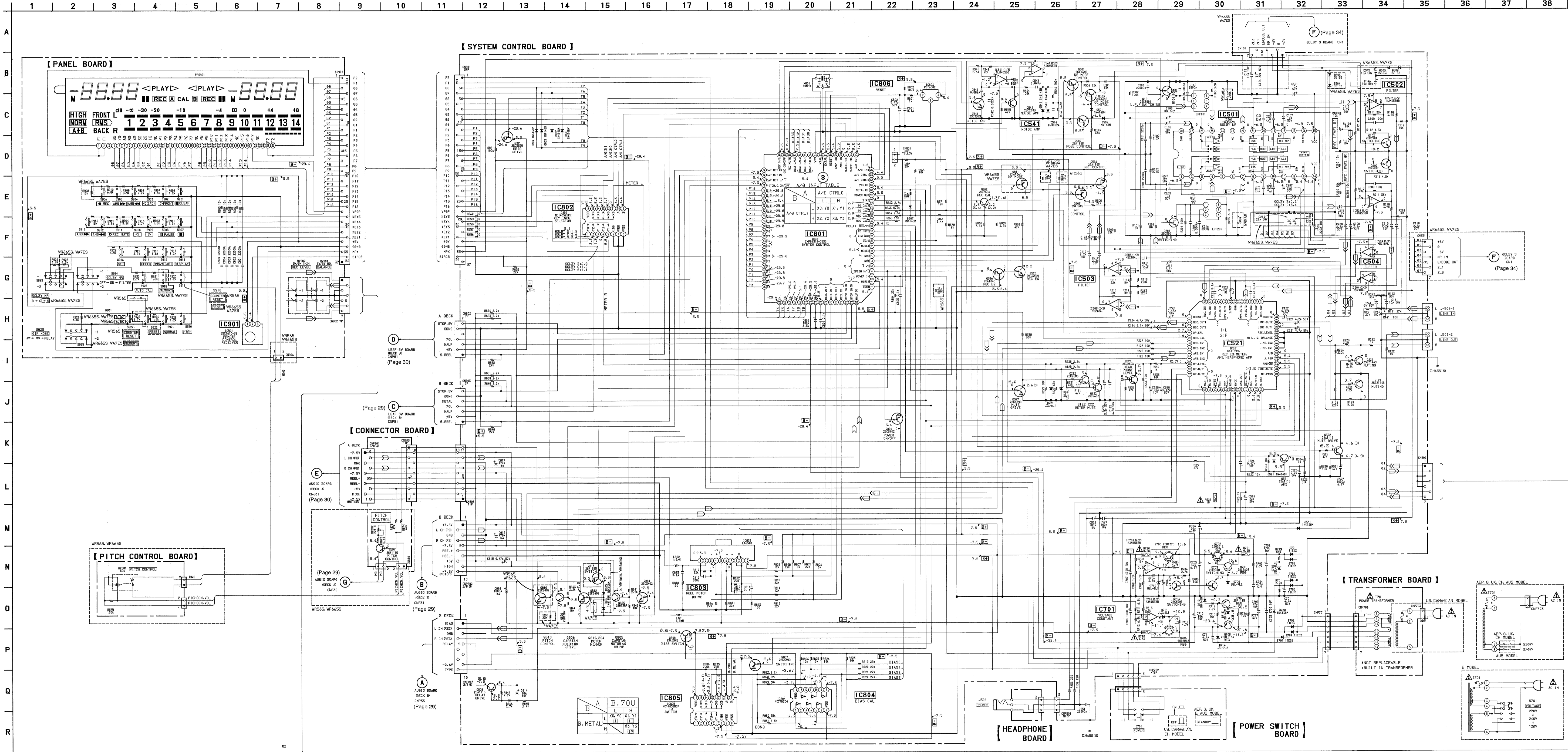

Note:

- All capacitors are in μ F unless otherwise noted. pF: μ μ F 50WV or less are not indicated except for electrolytics and tantalums.
- All resistors are in Ω and $\frac{1}{4}$ W or less unless otherwise specified.
- Δ : internal component.
- $\text{---}/\text{---}$: fusible resistor.

Note:
The components identified by mark Δ or dotted line with mark Δ are critical for safety. Replace only with part number specified.

Note:
Les composants identifiés par une marque Δ ou par une ligne pointillée avec une marque Δ sont critiques pour la sécurité. Ne les remplacer que par une pièce portant le numéro spécifié.

- --- : B+ Line
- --- : B- Line
- --- : adjustment for repair.

• Voltage and waveforms are dc with respect to ground under no-signal (detuned) conditions.
 () : STOP
 () : REC
 • Voltages are taken with a VOM (Input impedance 10M Ω). Voltage variations may be noted due to normal production tolerances.
 • Waveforms are taken with an oscilloscope. Voltage variations may be noted due to normal production tolerances.
 • Circled numbers refer to waveforms.
 • Signal path:
 ○ : PB (DECK A)
 □ : PB (DECK B)
 ▭ : REC (DECK B)
 • Abbreviation:
 CND: Canadian
 G: German
 AUS: Australian
 CH: Chinese

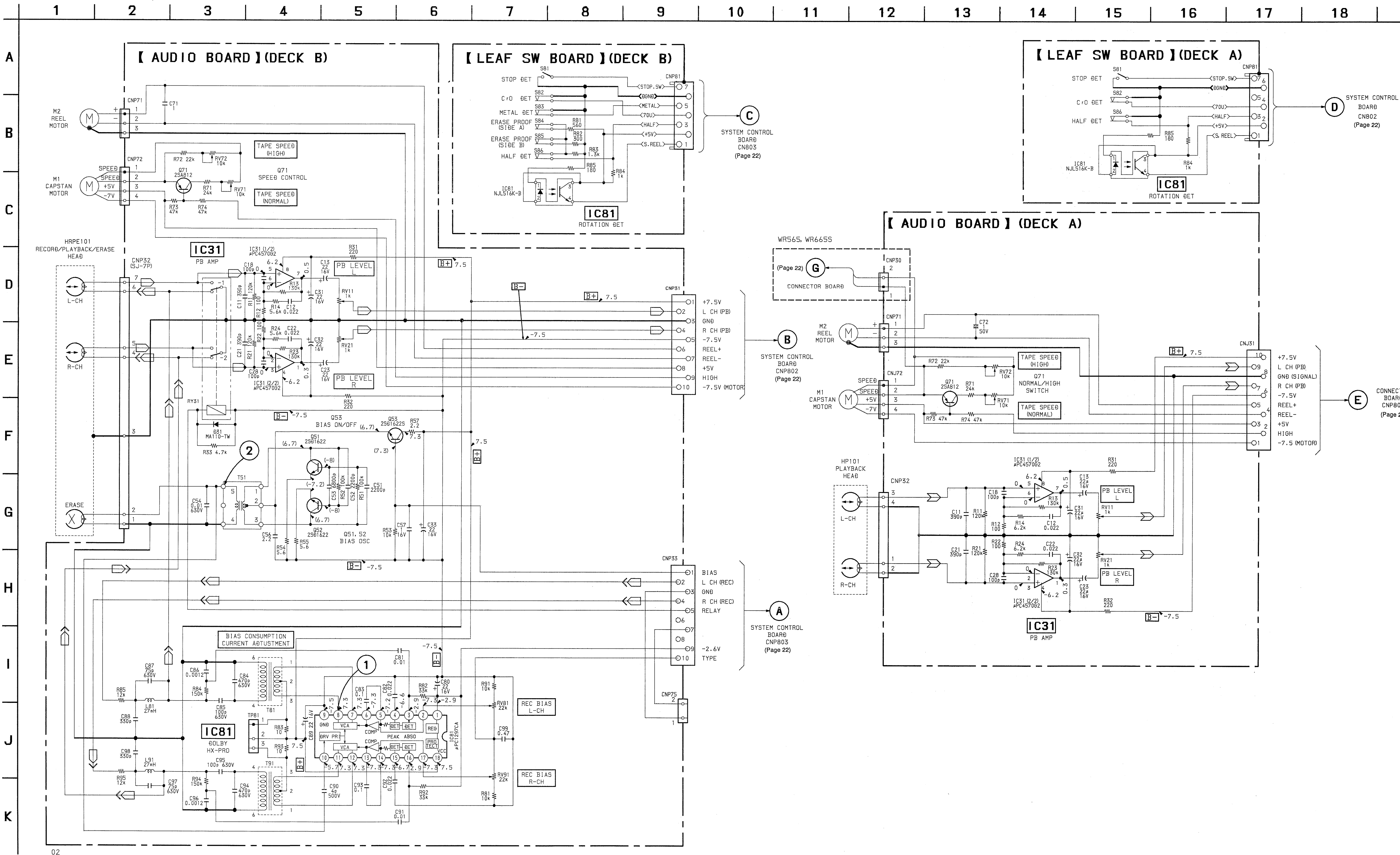

• WAVEFORMS - AUDIO SECTION -

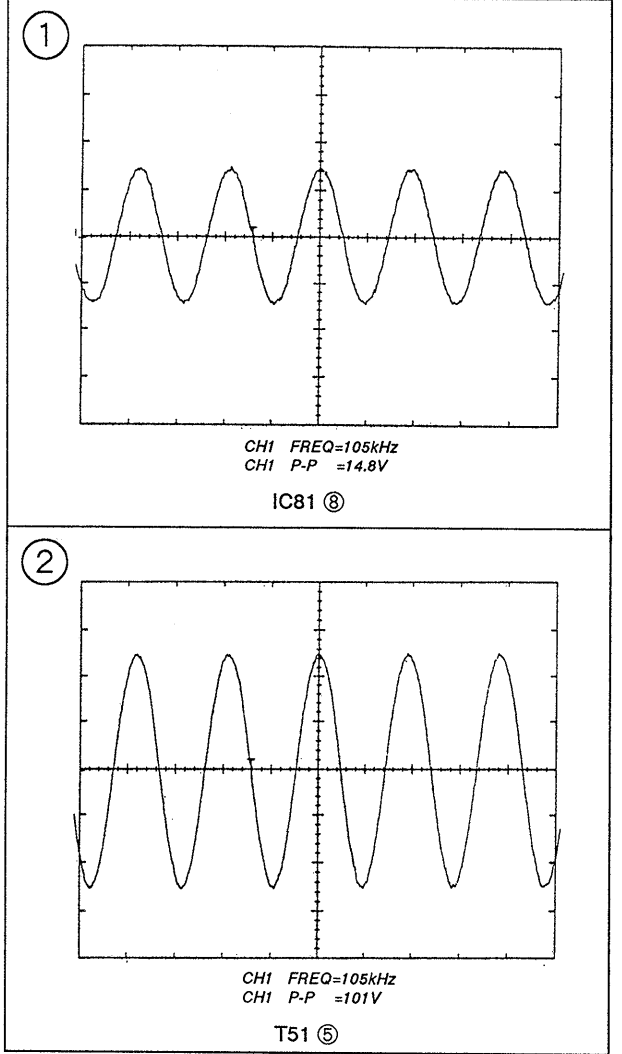

Note :

- All capacitors are in μ F unless otherwise noted. pF μ μ F 50WV or less are not indicated except for electrolytics and tantalums.
- All resistors are in Ω and $\frac{1}{4}$ W or less unless otherwise specified.
- [B+] : B+ Line
- [B-] : B- Line
- [] : adjustment for repair.
- Voltage and waveforms are dc with respect to ground under no-signal (detuned) conditions. no mark : STOP
- () : REC
- Voltagess are taken with a VOM (Input impedance 10M Ω). Voltage variations may be noted due to normal production tolerances.
- Waveforms are taken with an oscilloscope. Voltage variations may be noted due to normal production tolerances.
- Circled numbers refer to waveforms.
- Signal path.
 - : PB (DECK A)
 - : PB (DECK B)
 - : REC (DECK B)
- Abbreviation
 - CND : Canadian
 - G : German
 - AUS : Australian
 - CH : Chinese

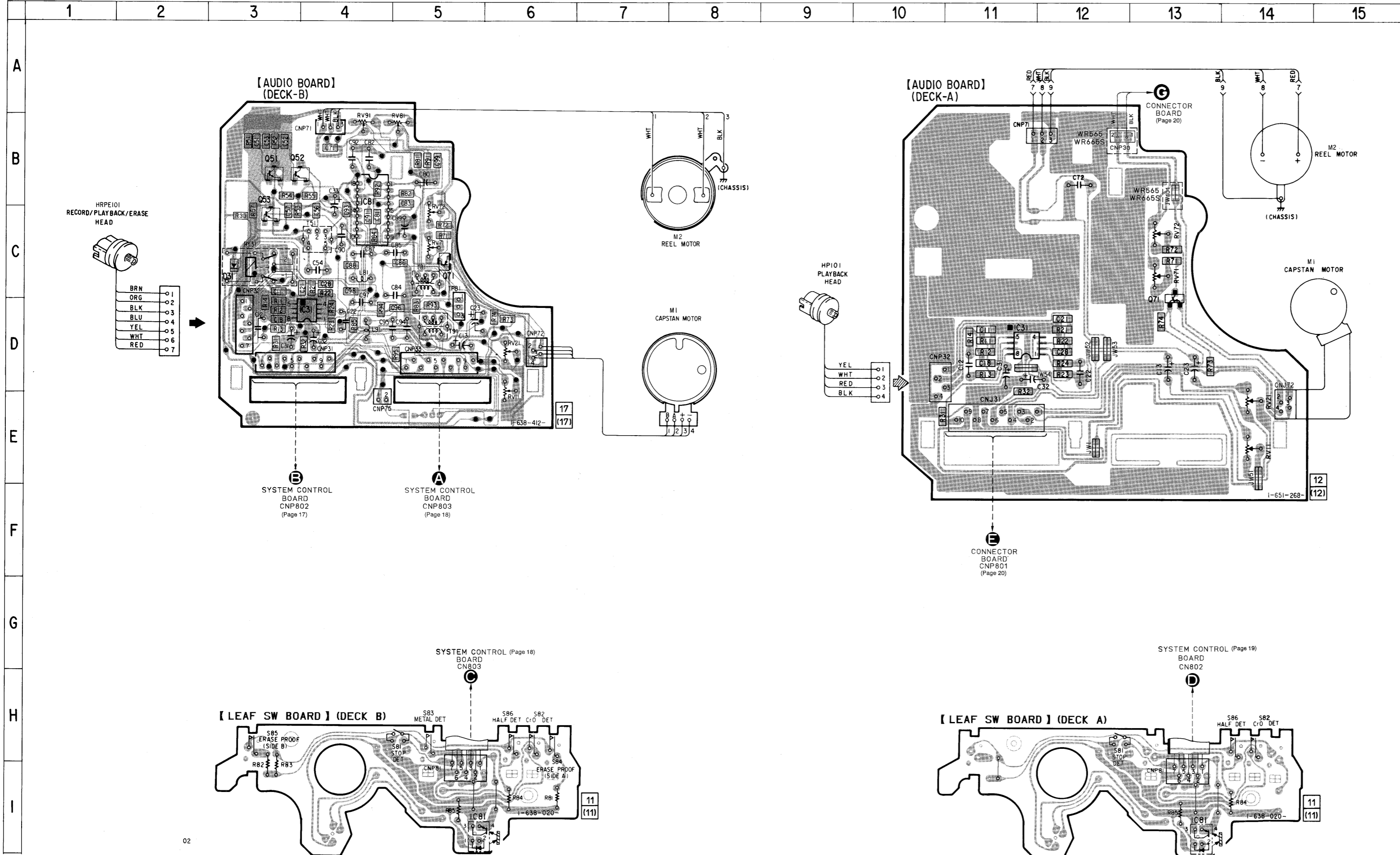

• SEMICONDUCTOR LOCATION (DECK-A)

Ref. No.	Location
IC31	D-11
IC81 (LEAF SW)	I-13
Q71	C-13

(DECK-B)

Ref. No.	Location
D31	C-3
IC31	D-4
IC81 (AUDIO)	I-5
IC81 (LEAF SW)	I-5
Q51	B-3
Q52	B-3
Q53	C-3
Q71	C-5

Note:
 • ○ : parts extracted from the component side.
 • ■ : parts mounted on the conductor side.
 • ● : Through hole.
 • [Pattern] : Pattern on the side which is seen.
 • [Pattern] : Pattern of the rear side.

5-6. PRINTED WIRING BOARDS (DOLBY (S) SECTION) • Refer to page 16 for Semiconductor Lead Layouts.

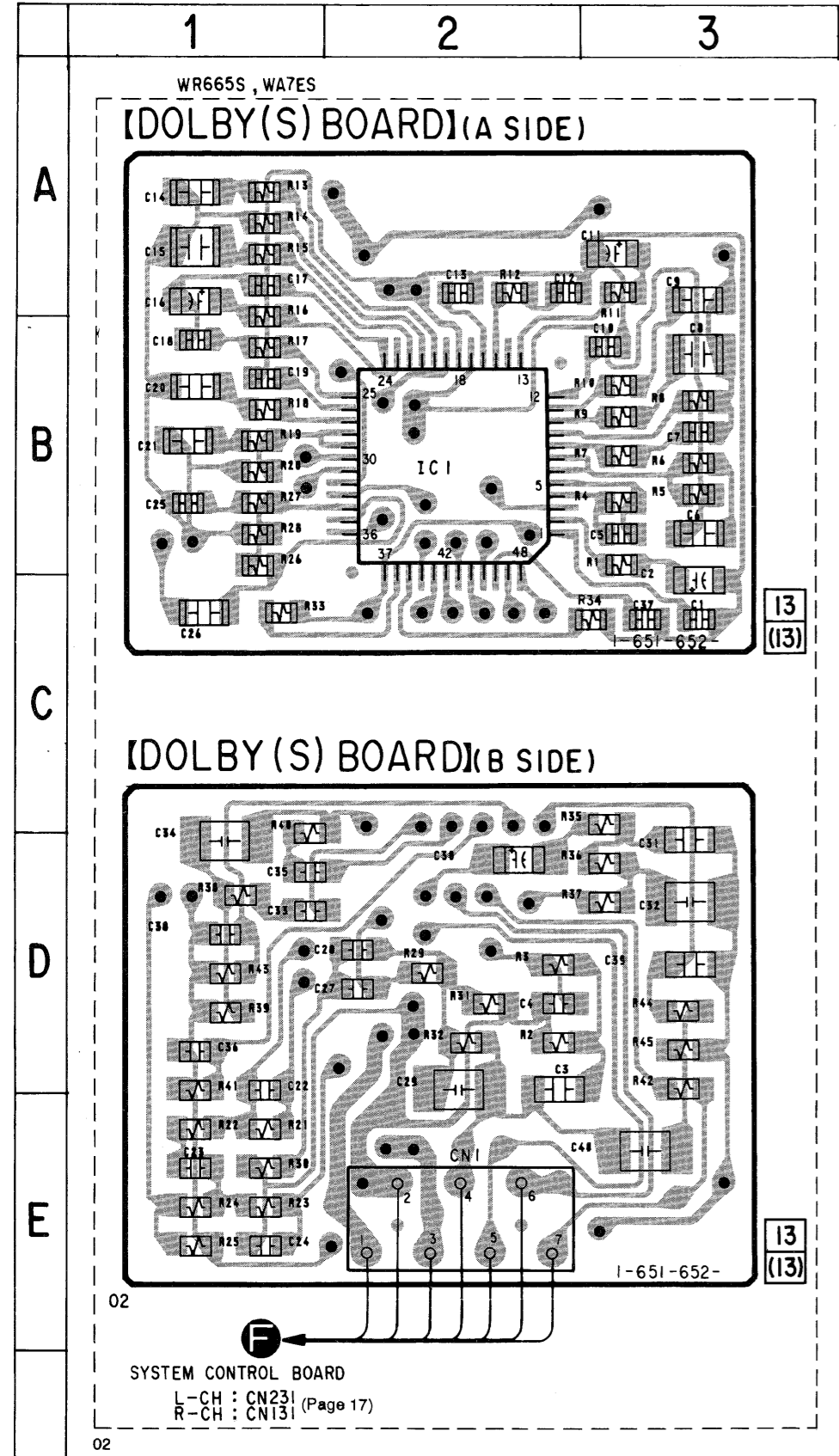

5-7. SCHEMATIC DIAGRAM (DOLBY (S) SECTION)

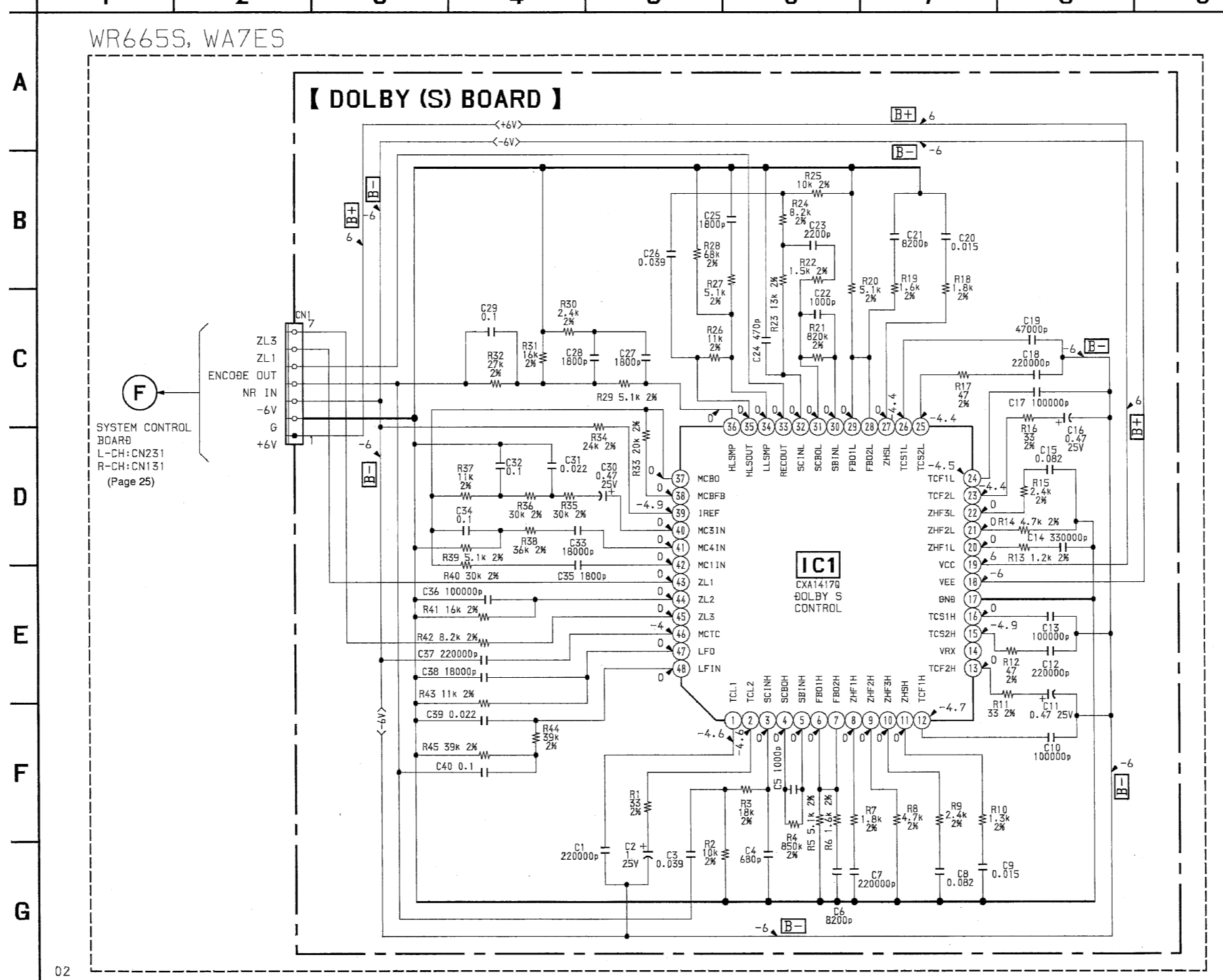

Note:

- : parts extracted from the component side.
- : Through hole.
- ▨ : Pattern from the side which enables seeing. (The other layers' patterns are not indicated)

Caution:

Pattern face side : Parts on the pattern face side seen from (Conductor Side) the pattern face are indicated.
 Parts face side : Parts on the parts face side seen from the (Component side) parts face are indicated.

Note:

- All capacitors are in μF unless otherwise noted. pF: $\mu \mu F$ 50WV or less are not indicated except for electrolytics and tantalums.
- All resistors are in Ω and $\frac{1}{4}W$ or less unless otherwise specified.
- % : indicates tolerance.
- B+** : B+ Line
- B-** : B- Line
- : adjustment for repair.
- Voltage and waveforms are dc with respect to ground under no-signal (detuned) conditions. no mark : STOP
- Voltagess are taken with a VOM (Input impedance 10M Ω). Voltage variations may be noted due to normal production tolerances.

• IC BLOCK DIAGRAMS

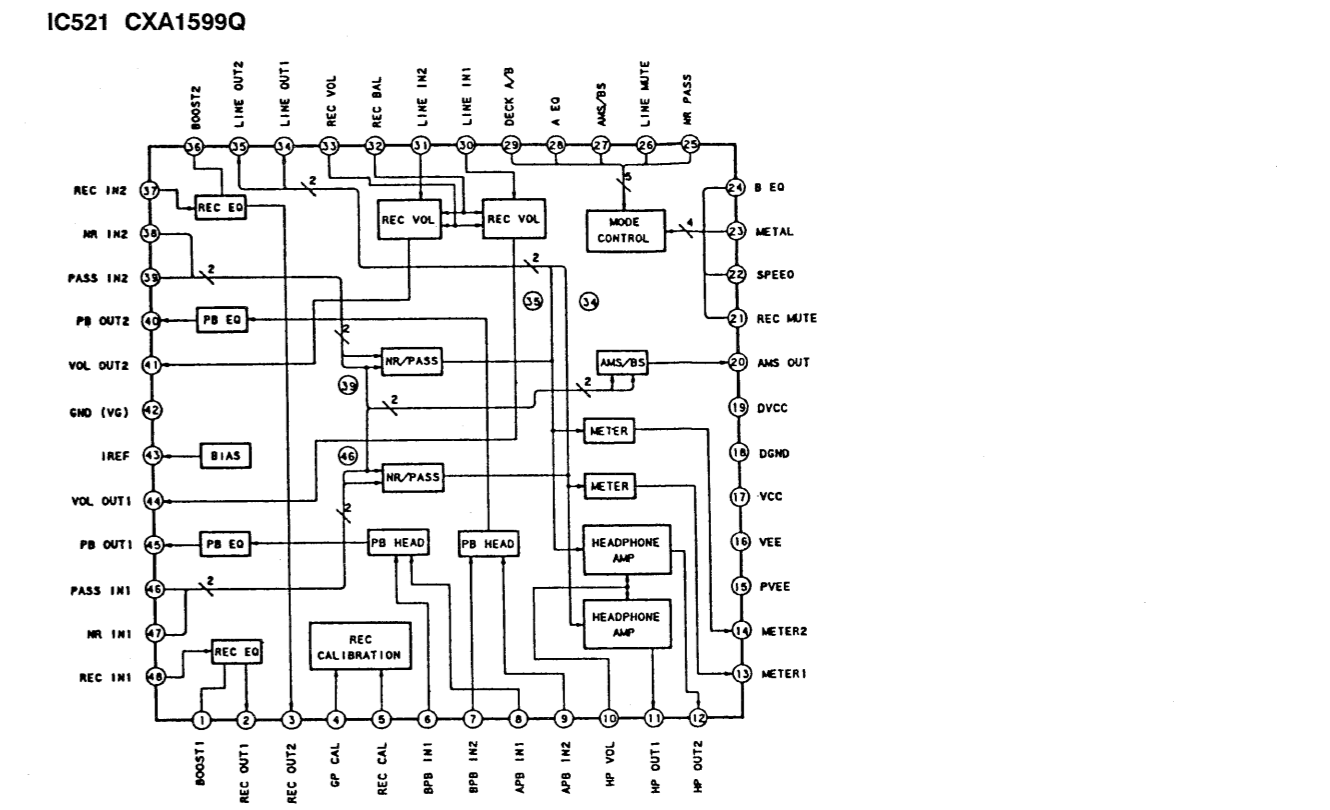
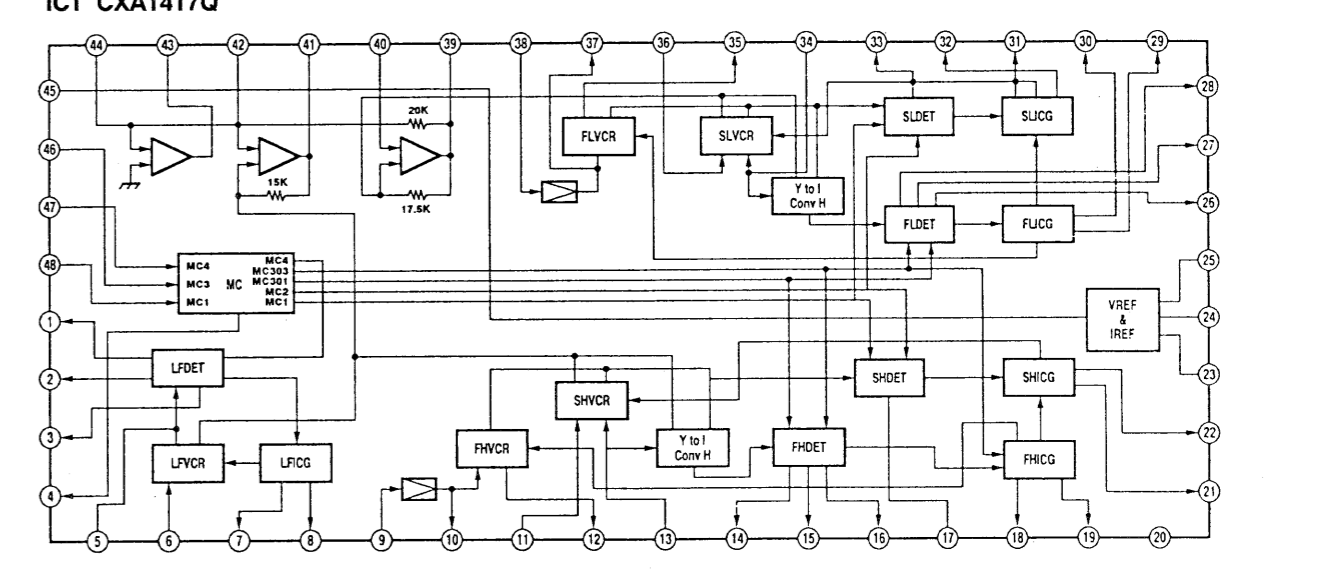

SECTION 6 EXPLODED VIEWS

NOTE :

- -XX, -X mean standardized parts, so they may have some difference from the original one.
- The construction parts of an assembled part are indicated with a collation number in the remark column.
- Items marked " * " are not stocked since they are seldom required for routine service. Some delay should be anticipated when ordering these items.

- The mechanical parts with no reference number in the exploded views are not supplied.
- Hardware (# mark) list and accessories and packing materials are given in the last of this parts list.
- Abbreviation
 CND : Canadian
 G : German
 AUS : Australian
 CH : Chinese

The components identified by mark or dotted line with mark are critical for safety. Replace only with part number specified.

Les composants identifiés par une marque sont critiques pour la sécurité. Ne les remplacer que par une pièce portant le numéro spécifié.

6-1. CHASSIS SECTION

- A : POWER TRANSFORMER BOARD
- B : CONNECTOR BOARD

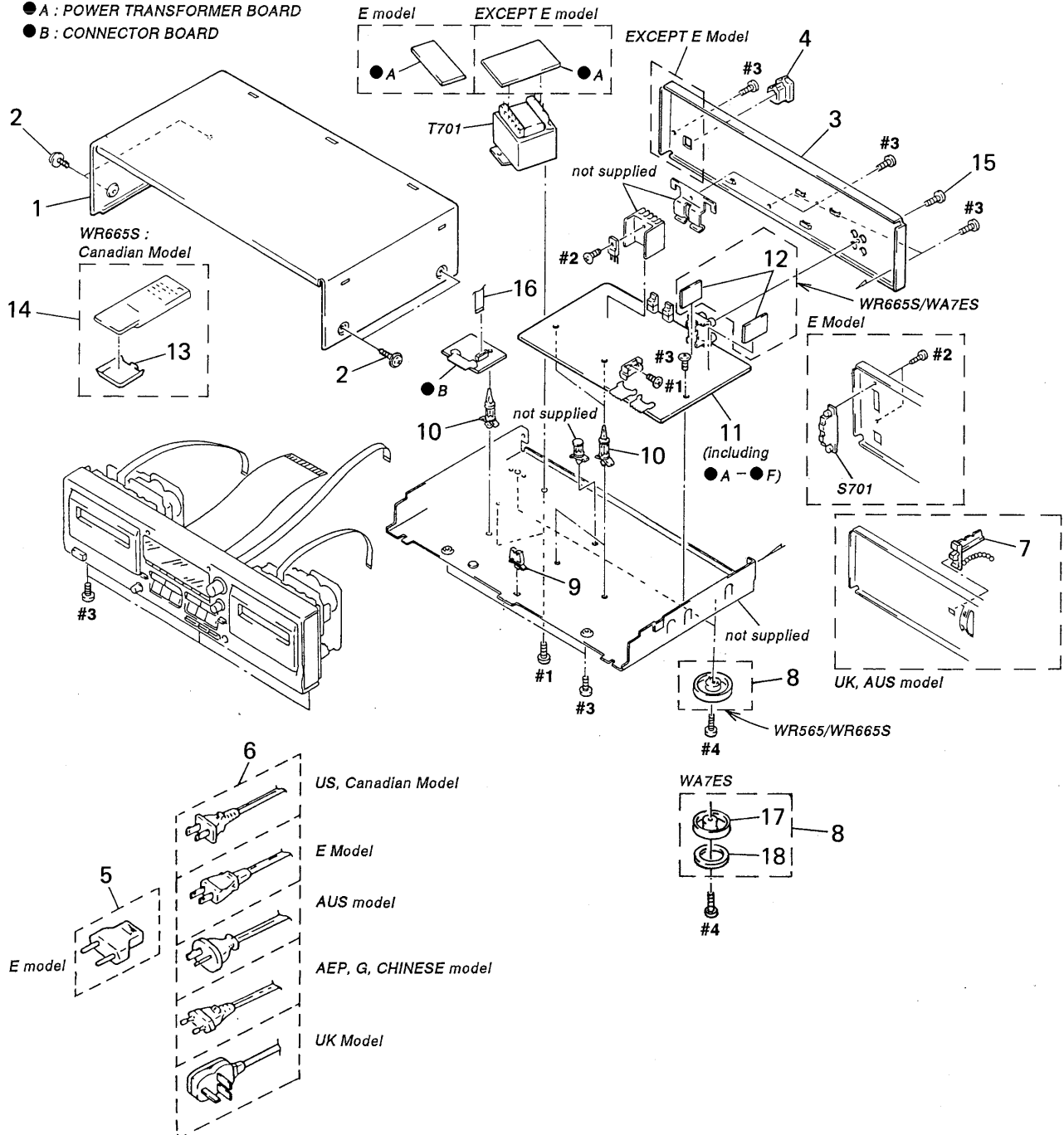

Ref. No.	Part No.	Description	Remark	Ref. No.	Part No.	Description	Remark
* 1	4-943-088-41	CASE		8	X-3369-843-1	FOOT ASSY (F58175S) (WR565:AEP, UK, E, G, AUS, CH/WR665S:AEP, UK, E, G, AUS, CH)	
2	3-363-099-01	SCREW (CASE 3 TP2)		8	X-4941-291-1	FOOT ASSY (F58175S) (WA7ES)	
* 3	3-920-372-01	PANEL, BACK (WR565:US)		* 9	4-308-840-11	HOLDER, WIRE	
* 3	3-920-372-11	PANEL, BACK (WR565:AEP, G)		* 10	3-346-265-31	HOLDER, PC BOARD	
* 3	3-920-372-21	PANEL, BACK (WR565:UK)		* 11	A-2007-311-A	SYSTEM CONTROL BOARD, COMPLETE (WR565:US, CND, AEP, UK, G, CH)	
* 3	3-920-372-31	PANEL, BACK (WR565:E)		* 11	A-2007-313-A	SYSTEM CONTROL BOARD, COMPLETE (WR565:AUS)	
* 3	3-920-372-41	PANEL, BACK (WR565:AUS)		* 11	A-2007-314-A	SYSTEM CONTROL BOARD, COMPLETE (WR565:E)	
* 3	3-920-372-51	PANEL, BACK (WR565:CND)		* 11	A-2007-315-A	SYSTEM CONTROL BOARD, COMPLETE (WR665S:US, CND, AEP, UK, G, CH)	
* 3	3-920-372-61	PANEL, BACK (WR565:CH)		* 11	A-2007-317-A	SYSTEM CONTROL BOARD, COMPLETE (WR665S:AUS)	
* 3	3-920-373-01	PANEL, BACK (WR665S:US)		* 11	A-2007-318-A	SYSTEM CONTROL BOARD, COMPLETE (WR665S:E)	
* 3	3-920-373-11	PANEL, BACK (WR665S:AEP, G)		* 11	A-2007-365-A	SYSTEM CONTROL BOARD, COMPLETE (WA7ES)	
* 3	3-920-373-21	PANEL, BACK (WR665S:UK)		* 12	A-2007-416-A	DOLBY (S) BOARD, COMPLETE (DECK A) (WA7ES, WR665S)	
* 3	3-920-373-31	PANEL, BACK (WR665S:E)		13	2-181-754-01	COVER, BATTERY (WR665S:CA)	
* 3	3-920-373-41	PANEL, BACK (WR665S:AUS)		14	1-465-738-11	REMOTE COMMANDER (WR665S:CA)	
* 3	3-920-373-51	PANEL, BACK (WR665S:CND)		15	3-704-515-01	SCREW (BV/RING)	
* 3	3-920-373-61	PANEL, BACK (WA7ES)		16	1-765-216-11	WIRE (FLAT TYPE) (11 CORE)	
* 3	3-920-373-71	PANEL, BACK (WR665S:CH)		17	3-318-688-51	FOOT (F58175S) (WA7ES)	
* 4	3-703-244-00	BUSHING (2104), CORD (AEP, UK, G, AUS, CH)		18	4-923-836-11	CUSHION (WA7ES)	
4	3-703-571-11	BUSHING (S) (4516), CORD (WA7ES/WR565:US, CND, E/WR665S:US, CND, E)		18	4-923-836-21	CUSHION (WA7ES)	
△5	1-569-007-11	ADAPTER, CONVERSION 2P (E)		△S701	1-692-155-11	SELECTOR, POWER VOLTAGE (E)	
△6	1-551-188-XX	CORD, POWER (E)		△T701	1-427-782-11	TRANSFORMER, POWER (US, CND)	
△6	1-558-945-21	CORD, POWER (POLAR. SPT-1) (US, CND)		△T701	1-427-783-11	TRANSFORMER, POWER (AEP, UK, G, AUS, CH)	
△6	1-575-651-21	CORD, POWER (AEP, G, CH)		△T701	1-427-784-11	TRANSFORMER, POWER (E)	
△6	1-696-586-11	CORD, POWER (UK)					
△6	1-696-845-11	CORD, POWER (AUS)					
7	4-956-370-12	BAND, PLUG FIXED (UK, AUS)					
8	X-3369-842-1	FOOT ASSY (F58175S) (WR565:US, CND/WR665S:US, CND)					

6-2. FRONT PANEL SECTION

- C : HEADPHONE BOARD
- D : PICH CONTROL BOARD
- E : PANEL BOARD
- F : POWER SWITCH BOARD

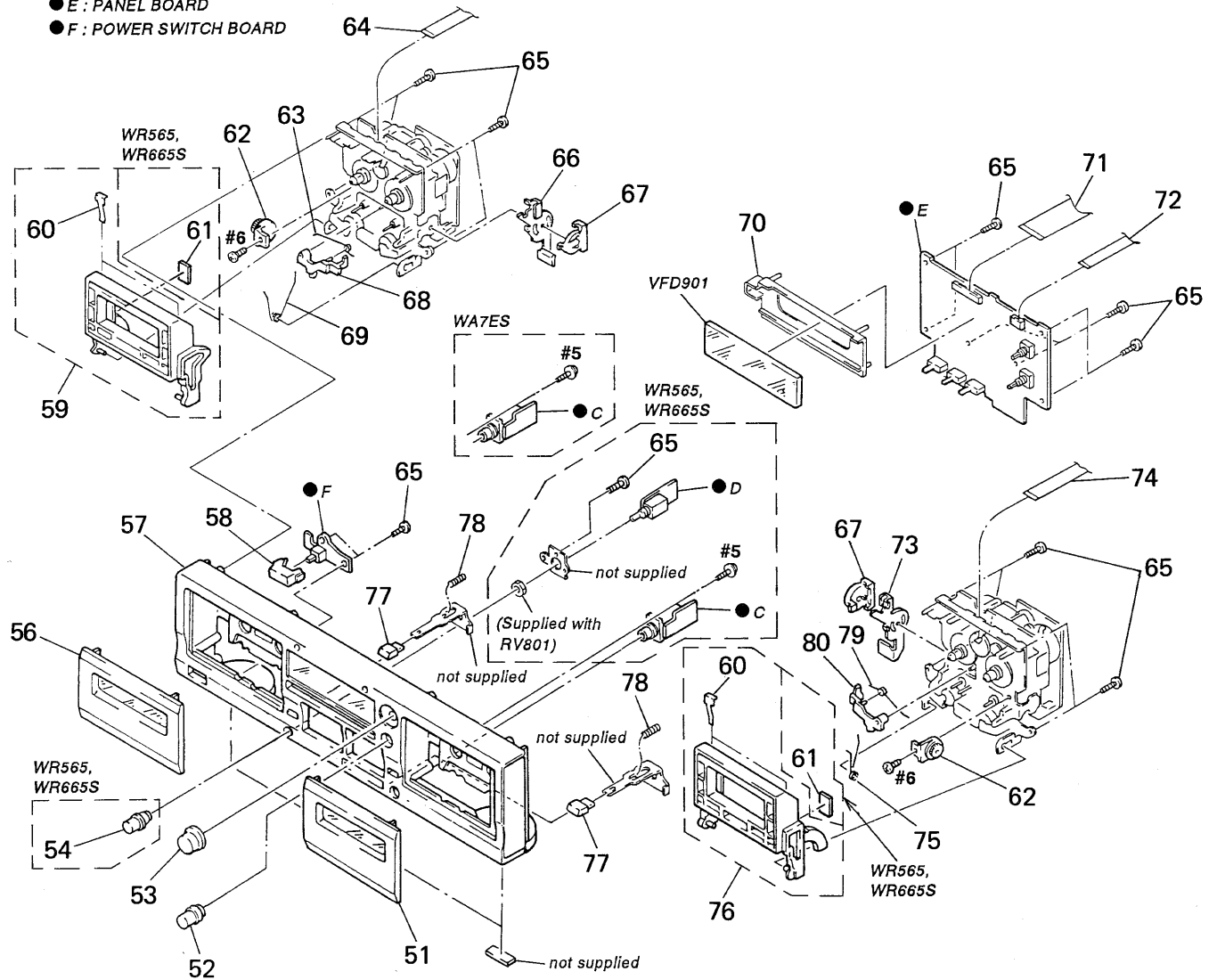

Ref. No.	Part No.	Description	Remark	Ref. No.	Part No.	Description	Remark
51	X-3369-653-1	LID (B) ASSY, CASSETTE (WR565)		62	3-354-963-01	DAMPER	
51	X-3369-655-1	LID (B) ASSY, CASSETTE (WR665S)		63	3-354-962-01	SPRING (EJ SAFTY SPRING R)	
51	X-3369-657-1	LID (B) ASSY, CASSETTE (WA7ES)		64	1-765-214-11	WIRE (FLAT TYPE) (7 CORE)	
52	3-367-431-01	KNOB (BAL)		65	4-951-620-01	SCREW (2.6×8), +BVTP	
53	3-909-661-01	KNOB (REC)		* 66	3-354-954-01	LEVER (LOCK LEVER R)	
54	3-920-370-01	KNOB (TS) (WR565, WR665S)		67	3-354-957-01	JOINT (LOCK LEVER)	
56	X-3369-652-1	LID (A) ASSY, CASSETTE (WR565)		68	3-354-956-01	LEVER (EJ SAFTY LEVER R)	
56	X-3369-654-1	LID (A) ASSY, CASSETTE (WR665S)		69	3-354-960-01	SPRING (LOADING R), TORSION	
56	X-3369-656-1	LID (A) ASSY, CASSETTE (WA7ES)		* 70	3-377-337-11	HOLDER (FL)	
57	X-3369-646-1	PANEL ASSY, FRONT (WR565:US, CND)		71	1-765-217-11	WIRE (FLAT TYPE) (37 CORE)	
57	X-3369-647-1	PANEL ASSY, FRONT (WR565:AEP, UK, E, G, AUS, CH)		72	1-765-215-11	WIRE (FLAT TYPE) (7 CORE)	
57	X-3369-648-1	PANEL ASSY, FRONT (WR665S:US)		* 73	3-354-953-01	LEVER (LOCK LEVER L)	
57	X-3369-649-1	PANEL ASSY, FRONT (WR665S:CND)		74	1-765-213-11	WIRE (FLAT TYPE) (7 CORE)	
57	X-3369-650-1	PANEL ASSY, FRONT (WR665S:CH)		75	3-354-959-01	SPRING (LOADING L), TORSION	
57	X-3369-651-1	PANEL ASSY, FRONT (WA7ES)		76	A-2004-501-A	HOLDER (L) ASSY, CASSETTE (WA7ES)	
58	3-354-932-01	BUTTON (POWER)		76	A-4325-163-A	HOLDER (L) ASSY, CASSETTE (WR565, WR665S)	
59	A-2004-502-A	HOLDER (R) ASSY, CASSETTE (WA7ES)		77	3-377-328-11	BUTTON (EJECT)	
59	A-4325-164-A	HOLDER (R) ASSY, CASSETTE (WR565, WR665S)		78	3-382-382-11	SPRING, COMPRESSION	
60	3-308-823-11	DETENT, CASSETTE		79	3-354-961-01	SPRING (EJ SAFTY SPRING L)	
* 61	3-387-151-01	CUSHION, RUBBER (WR565, WR665S)		80	3-354-955-01	LEVER (EJ SAFTY LEVER L)	
				VFD901	1-517-263-11	INDICATOR TUBE, FLUORESCENT	

6-3. MECHANISM SECTION 1

(TCM-190RA14CL : DECK-A) : TC-WR565/WR665S

(TCM-190RA12CL : DECK-A) : TC-WA7ES

(TCM-190RB12CL : DECK-B) : TC-WR565/WR665S/TC-WA7ES

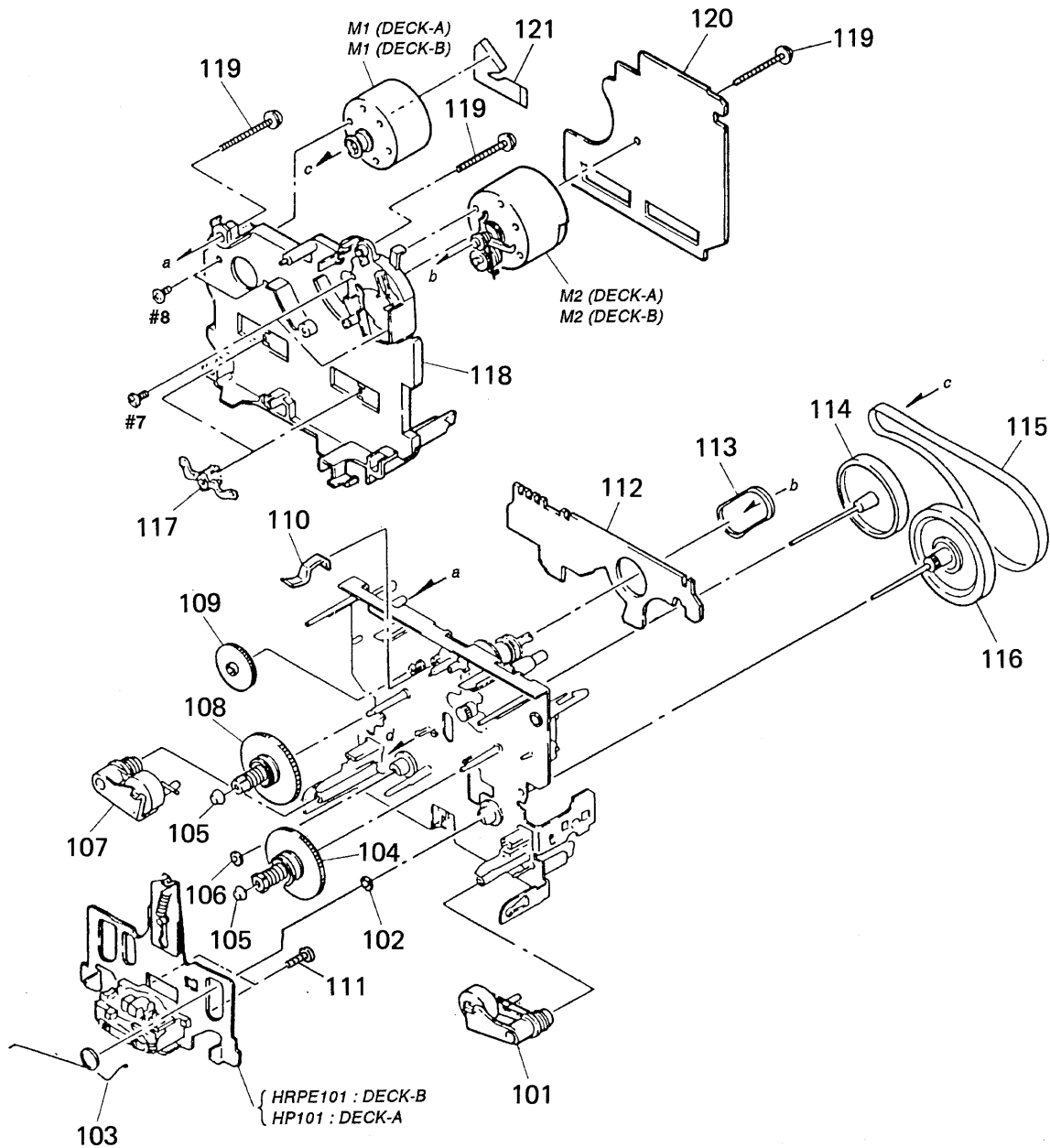

Ref. No.	Part No.	Description	Remark
101	X-3366-047-1	LEVER (PINCH F) ASSY	
102	3-356-713-01	WASHER	
103	3-907-362-01	SPRING, TORSION	
104	X-3366-970-1	TABLE ASSY, REEL	
105	3-362-308-01	CAP (REEL)	
106	3-356-714-01	WASHER	
107	X-3366-048-1	LEVER (PINCH R) ASSY	
108	X-3366-971-1	TABLE ASSY (B), REEL	
109	3-359-424-01	GEAR (REV GEAR)	
110	3-359-430-01	SPRING (CASSETTE RETAINER), LEAF	
111	3-388-848-01	SCREW (P2×6) (B TIGHT)	
* 112	1-638-020-11	LEAF SW BOARD (DECK A)	
* 112	1-638-020-11	LEAF SW BOARD (DECK B)	
113	3-359-466-01	BELT (FR), SQUARE	
114	X-3367-630-1	FLYWHEEL (REV) ASSY	
115	3-359-417-01	BELT (FLAT), CAPSTAN	

Ref. No.	Part No.	Description	Remark
116	X-3367-629-1	FLYWHEEL (FWD) ASSY	
117	3-575-321-00	RETAINER, THRUST, CAPSTAN	
118	3-359-436-11	BASE (THRUST RETAINER), FITTING	
119	3-359-414-01	SCREW (+PTPWH 2×23)	
* 120	A-2007-040-A	AUDIO BOARD, COMPLETEETE (DECK B)	
* 120	A-2007-266-A	AUDIO BOARD, COMPLETEETE (DECK A)	(WA7ES)
* 120	A-2007-339-A	AUDIO BOARD, COMPLETEETE (DECK A)	(WR565, WR665S)
121	1-638-983-11	PC BOARD, MOTOR FLEXIBLE	
HP101	A-2003-757-A	BASE ASSY, HEAD (PLAY BACK) (DECK A)	
HRPE101A-2003-930-A	BASE ASSY, HEAD	(RECORD, PLAYBACK, ERASE) (DECK B)	
M1	X-3365-377-2	MOTOR ASSY, CAPSTAN (DECK A)	
M1	X-3365-377-2	MOTOR ASSY, CAPSTAN (DECK B)	
M2	X-3363-501-1	MOTOR ASSY, REEL (DECK A)	
M2	X-3363-501-1	MOTOR ASSY, REEL (DECK B)	

6-4. MECHANISM SECTION 2

(TCM-190RA14CL : DECK-A) : TC-WR565/WR665S

(TCM-190RA12CL : DECK-A) : TC-WA7ES

(TCM-190RB12CL : DECK-B) : TC-WR565/WR665S/TC-WA7ES

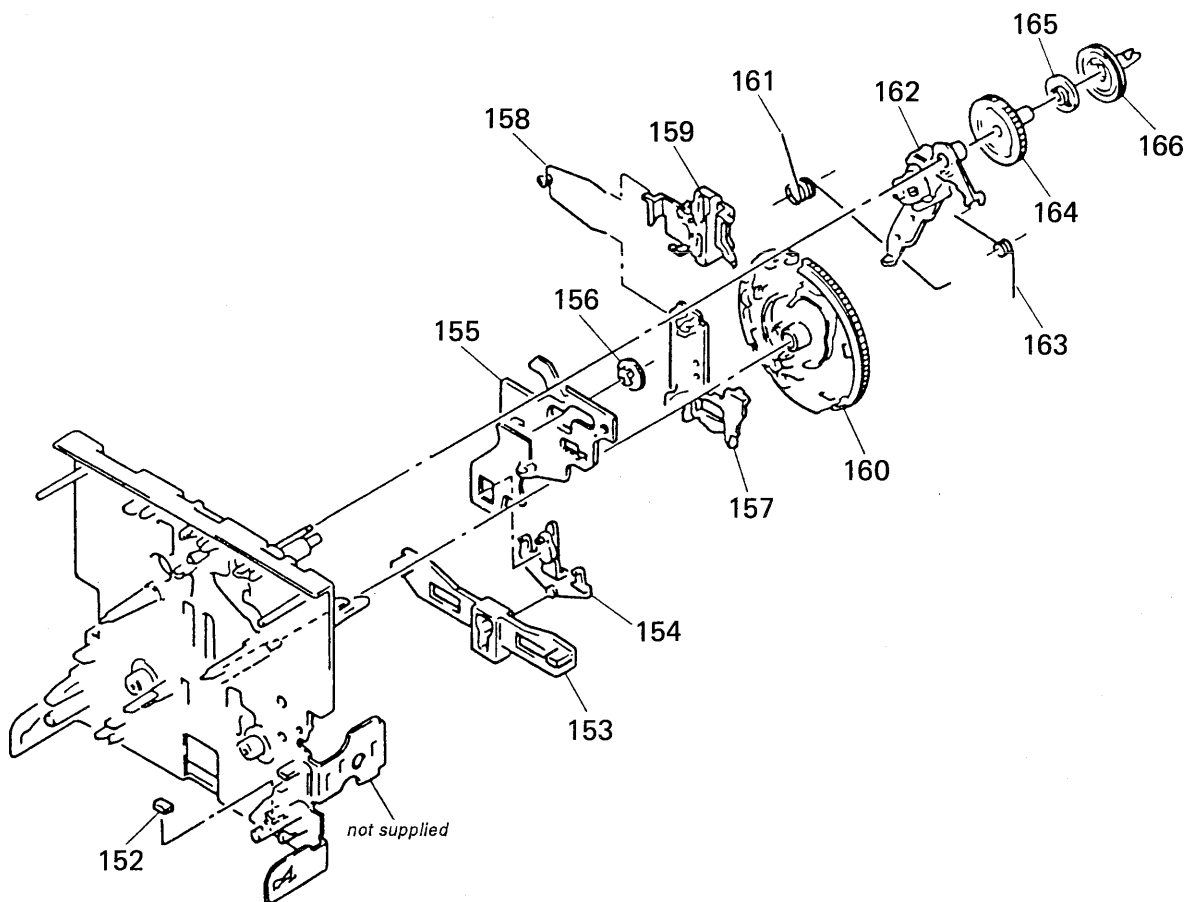

Ref.No.	Part No.	Description	Remark	Ref.No.	Part No.	Description	Remark
152	3-359-469-01	SPACER		160	3-359-420-01	GEAR (CAM GEAR)	
153	3-359-425-01	SLIDER (REVERSE SLIDER)		161	3-359-456-01	SPRING (TRIGGER SPRING), TORSION	
154	3-359-426-01	LEVER (REVERSE LEVER)		162	X-3366-569-1	ARM ASSY, FR	
* 155	3-359-415-01	SLIDER (TRIGGER SLIDER)		163	3-924-185-11	SPRING (FR ARM), TORSION	
156	3-359-448-01	GEAR (TRIGGER)		164	3-359-419-11	GEAR (FR GEAR)	
157	3-359-427-01	SLIDER (LEVERSE SLIDER)		165	3-359-421-01	CLUTCH (REEL DISK)	
158	3-359-454-01	SPRING, TORSION		166	3-359-418-01	PULLEY (FR PULLEY)	
159	3-359-429-01	SLIDER (BRAKE PLATE)					

SECTION 7 ELECTRICAL PARTS LIST

AUDIO (DECK A)

AUDIO (DECK B)

NOTE :

- Due to standardization, replacements in the parts list may be different from the parts specified in the diagrams or the components used on the set.
- -XX, -X mean standardized parts, so they may have some difference from the original one.
- RESISTORS
All resistors are in ohms
METAL : Metal-film resistor
METAL OXIDE : Metal oxide-film resistor
F : nonflammable

- Items marked " * " are not stocked since they are seldom required for routine service. Some delay should be anticipated when ordering these items.
- SEMICONDUCTORS
In each case, u : μ , for example :
uA.... : μ A...., uPA.... : μ PA....
uPB.... : μ PB...., uPC.... : μ PC....
uPD.... : μ PD....
- CAPACITORS
uF : μ F
- COILS
uH : μ H

The components identified by mark Δ or dotted line with mark Δ are critical for safety. Replace only with part number specified.

Les composants identifiés par une marque Δ sont critiques pour la sécurité. Ne les remplacer que par une pièce portant le numéro spécifié.

When indicating parts by reference number, please include the board.

Ref. No.	Part No.	Description	Remark
*	A-2007-266-A	AUDIO BOARD, COMPLETE (DECK A)	(WA7ES)
*	A-2007-339-A	AUDIO BOARD, COMPLETE (DECK A)	(WR565, WR665S)

< CAPACITOR >			
C11	1-163-131-00	CERAMIC CHIP	390PF 5% 50V
C12	1-136-157-00	FILM	0.022uF 5% 50V
C13	1-124-234-00	ELECT	22uF 20% 16V
C18	1-163-117-00	CERAMIC CHIP	100PF 5% 50V
C21	1-163-131-00	CERAMIC CHIP	390PF 5% 50V
C22	1-136-157-00	FILM	0.022uF 5% 50V
C23	1-124-234-00	ELECT	22uF 20% 16V
C28	1-163-117-00	CERAMIC CHIP	100PF 5% 50V
C31	1-124-234-00	ELECT	22uF 20% 16V
C32	1-124-234-00	ELECT	22uF 20% 16V
C72	1-124-499-11	ELECT, NONPOLAR 1uF	20% 50V
< JACK >			
* CNJ31	1-580-782-11	CONNECTOR, BOARD TO BOARD	
CNJ72	1-764-902-11	CONNECTOR, FFC/FPC 4P	
< CONNECTOR >			
* CNP30	1-564-718-11	PIN, CONNECTOR (SMALL TYPE) 2P	(WR565, WR665S)
* CNP32	1-580-772-11	PIN, CONNECTOR (PC BOARD) 4P	
* CNP71	1-564-719-11	PIN, CONNECTOR (SMALL TYPE) 3P	
< IC >			
IC31	8-759-106-02	IC uPC4570G2	
< JUMPER RESISTOR >			
JW1	1-216-295-00	METAL CHIP	0 5% 1/10W
JW51	1-216-296-00	METAL CHIP	0 5% 1/8W
JW52	1-216-296-00	METAL CHIP	0 5% 1/8W
JW53	1-216-296-00	METAL CHIP	0 5% 1/8W
JW54	1-216-296-00	METAL CHIP	0 5% 1/8W
JW101	1-216-295-00	METAL CHIP	0 5% 1/8W (WR565, WR665S)

Ref. No.	Part No.	Description	Remark
< TRANSISTOR >			
Q71	8-729-216-22	TRANSISTOR	2SA1162-G
< RESISTOR >			
R11	1-216-099-00	METAL CHIP	120K 5% 1/10W
R12	1-216-025-00	METAL GLAZE	100 5% 1/10W
R13	1-216-100-00	METAL GLAZE	130K 5% 1/10W
R14	1-216-068-00	METAL CHIP	6.2K 5% 1/10W
R21	1-216-099-00	METAL CHIP	120K 5% 1/10W
R22	1-216-025-00	METAL GLAZE	100 5% 1/10W
R23	1-216-100-00	METAL GLAZE	130K 5% 1/10W
R24	1-216-068-00	METAL CHIP	6.2K 5% 1/10W
R31	1-216-033-00	METAL CHIP	220 5% 1/10W
R32	1-216-033-00	METAL CHIP	220 5% 1/10W
R71	1-216-082-00	METAL GLAZE	24K 5% 1/10W
R72	1-216-081-00	METAL CHIP	22K 5% 1/10W
R73	1-216-089-00	METAL CHIP	47K 5% 1/10W
R74	1-216-089-00	METAL CHIP	47K 5% 1/10W
< VARIABLE RESISTOR >			
RV11	1-241-761-11	RES, ADJ, CARBON 1K (PB LEVEL, L)	
RV21	1-241-761-11	RES, ADJ, CARBON 1K (PB LEVEL, R)	
RV71	1-241-630-11	RES, ADJ, CARBON 10K (TAPE SPEED, NORMAL)	
RV72	1-241-630-11	RES, ADJ, CARBON 10K (TAPE SPEED, HIGH)	

*	A-2007-040-A	AUDIO BOARD, COMPLETE (DECK B)	

< CAPACITOR >			
C11	1-163-131-00	CERAMIC CHIP	390PF 5% 50V
C12	1-136-157-00	FILM	0.022uF 5% 50V
C13	1-124-234-00	ELECT	22uF 20% 16V
C18	1-163-117-00	CERAMIC CHIP	100PF 5% 50V
C21	1-163-131-00	CERAMIC CHIP	390PF 5% 50V
C22	1-136-157-00	FILM	0.022uF 5% 50V
C23	1-124-234-00	ELECT	22uF 20% 16V
C28	1-163-117-00	CERAMIC CHIP	100PF 5% 50V
C31	1-124-234-00	ELECT	22uF 20% 16V
C32	1-124-234-00	ELECT	22uF 20% 16V

AUDIO (DECK B)

Ref.No.	Part No.	Description	Remark	Ref.No.	Part No.	Description	Remark
C33	1-124-234-00	ELECT	22uF 20% 16V			< TRANSISTOR >	
C51	1-164-161-11	CERAMIC CHIP	0.0022uF 10% 100V	Q51	8-729-808-01	TRANSISTOR 2SD1622-S	
C52	1-164-161-11	CERAMIC CHIP	0.0022uF 10% 100V	Q52	8-729-808-01	TRANSISTOR 2SD1622-S	
C53	1-163-019-00	CERAMIC CHIP	0.0068uF 10% 50V	Q53	8-729-808-01	TRANSISTOR 2SD1622-S	
C54	1-136-601-11	FILM	0.01uF 5% 630V	Q71	8-729-216-22	TRANSISTOR 2SA1162-G	
C56	1-164-505-11	CERAMIC CHIP	2.2uF 16V			< RESISTOR >	
C57	1-164-346-11	CERAMIC CHIP	1uF 16V	R11	1-216-099-00	METAL CHIP 120K 5% 1/10W	
C71	1-164-346-11	CERAMIC CHIP	1uF 16V	R12	1-216-025-00	METAL GLAZE 100 5% 1/10W	
C80	1-124-234-00	ELECT	22uF 20% 16V	R13	1-216-100-00	METAL GLAZE 130K 5% 1/10W	
C81	1-164-232-11	CERAMIC CHIP	0.01uF 50V	R14	1-216-067-00	METAL CHIP 5.6K 5% 1/10W	
C82	1-136-157-00	FILM	0.022uF 5% 50V	R21	1-216-099-00	METAL CHIP 120K 5% 1/10W	
C83	1-164-004-11	CERAMIC CHIP	0.1uF 10% 25V	R22	1-216-025-00	METAL GLAZE 100 5% 1/10W	
C84	1-136-478-11	FILM	470PF 5% 630V	R23	1-216-100-00	METAL GLAZE 130K 5% 1/10W	
C85	1-136-433-11	FILM	100PF 5% 630V	R24	1-216-067-00	METAL CHIP 5.6K 5% 1/10W	
C86	1-163-143-00	CERAMIC CHIP	0.0012uF 5% 50V	R31	1-216-033-00	METAL CHIP 220 5% 1/10W	
C87	1-136-273-91	FILM	75PF 5% 630V	R32	1-216-033-00	METAL CHIP 220 5% 1/10W	
C88	1-163-003-11	CERAMIC CHIP	330PF 10% 50V	R33	1-216-065-00	METAL CHIP 4.7K 5% 1/10W	
C89	1-124-234-00	ELECT	22uF 20% 16V	R51	1-216-097-00	METAL CHIP 100K 5% 1/10W	
C90	1-107-584-11	CERAMIC	4PF 0.25PF 500V	R52	1-216-097-00	METAL CHIP 100K 5% 1/10W	
C91	1-164-232-11	CERAMIC CHIP	0.01uF 50V	R53	1-216-073-00	METAL CHIP 10K 5% 1/10W	
C92	1-136-157-00	FILM	0.022uF 5% 50V	R54	1-216-309-00	METAL CHIP 5.6 5% 1/10W	
C93	1-164-004-11	CERAMIC CHIP	0.1uF 10% 25V	R55	1-216-309-00	METAL CHIP 5.6 5% 1/10W	
C94	1-136-478-11	FILM	470PF 5% 630V	R57	1-216-298-00	METAL CHIP 2.2 5% 1/10W	
C95	1-136-433-11	FILM	100PF 5% 630V	R71	1-216-082-00	METAL GLAZE 24K 5% 1/10W	
C96	1-163-143-00	CERAMIC CHIP	0.0012uF 5% 50V	R72	1-216-081-00	METAL CHIP 22K 5% 1/10W	
C97	1-136-273-91	FILM	75PF 5% 630V	R73	1-216-089-00	METAL CHIP 47K 5% 1/10W	
C98	1-163-003-11	CERAMIC CHIP	330PF 10% 50V	R74	1-216-089-00	METAL CHIP 47K 5% 1/10W	
C99	1-164-005-11	CERAMIC CHIP	0.47uF 25V	R81	1-216-073-00	METAL CHIP 10K 5% 1/10W	
		< CONNECTOR >		R82	1-216-085-00	METAL CHIP 33K 5% 1/10W	
* CNP31	1-580-782-11	CONNECTOR, BOARD TO BOARD		R83	1-216-001-00	METAL CHIP 10 5% 1/10W	
* CNP32	1-580-781-11	PIN, CONNECTOR (PC BOARD) 7P		R84	1-216-101-00	METAL CHIP 150K 5% 1/10W	
* CNP33	1-580-782-11	CONNECTOR, BOARD TO BOARD		R85	1-216-075-00	METAL CHIP 12K 5% 1/10W	
* CNP71	1-564-719-11	PIN, CONNECTOR (SMALL TYPE) 3P		R91	1-216-073-00	METAL CHIP 10K 5% 1/10W	
CNP72	1-764-902-11	CONNECTOR, FFC/FPC 4P		R92	1-216-085-00	METAL CHIP 33K 5% 1/10W	
* CNP75	1-564-718-11	PIN, CONNECTOR (SMALL TYPE) 2P		R93	1-216-001-00	METAL CHIP 10 5% 1/10W	
		< DIODE >		R94	1-216-101-00	METAL CHIP 150K 5% 1/10W	
D31	8-719-404-46	DIODE MA110		R95	1-216-075-00	METAL CHIP 12K 5% 1/10W	
		< IC >				< VARIABLE RESISTOR >	
IC31	8-759-106-02	IC uPC4570G2		RV11	1-241-761-11	RES, ADJ, CARBON 1K (PB LEVEL, L)	
IC81	8-759-106-56	IC uPC1297CA		RV21	1-241-761-11	RES, ADJ, CARBON 1K (PB LEVEL, R)	
		< COIL >		RV71	1-241-630-11	RES, ADJ, CARBON 10K (TAPE SPEED, NORMAL)	
L81	1-410-780-11	INDUCTOR 27mH		RV72	1-241-630-11	RES, ADJ, CARBON 10K (TAPE SPEED, HIGH)	
L91	1-410-780-11	INDUCTOR 27mH		RV81	1-241-786-11	RES, ADJ, CARBON 22K (REC BIAS, L)	
				RV91	1-241-786-11	RES, ADJ, CARBON 22K (REC BIAS, R)	

AUDIO (DECK B)

DOLBY (S)

Ref.No.	Part No.	Description	Remark
		< RELAY >	
RY31	1-515-913-11	RELAY	
		< TRANSFORMER >	
T51	1-406-417-11	COIL, BIAS OSCILLATION	
T81	1-433-381-11	TRANSFORMER, BIAS OSCILLATOR	
T91	1-433-381-11	TRANSFORMER, BIAS OSCILLATOR	
		< TEST PIN >	
* TP81	1-568-449-11	HOUSING, CONNECTOR (PC BOARD) 3P	

* A-2007-416-A	DOLBY (S) BOARD, COMPLETE (WA7ES, WR665S)		

		< CAPACITOR >	
C1	1-164-222-11	CERAMIC CHIP 0.22uF	25V
C2	1-135-177-21	TANTALUM CHIP 1uF	20% 20V
C3	1-104-558-11	FILM CHIP 0.039uF	5% 16V
C4	1-163-007-11	CERAMIC CHIP 680PF	10% 50V
C5	1-163-009-11	CERAMIC CHIP 0.001uF	10% 50V
C6	1-164-717-11	CERAMIC CHIP 0.0082uF	5% 50V
C7	1-164-222-11	CERAMIC CHIP 0.22uF	25V
C8	1-104-562-11	FILM CHIP 0.082uF	5% 16V
C9	1-104-553-11	FILM CHIP 0.015uF	5% 16V
C10	1-165-319-11	CERAMIC CHIP 0.1uF	50V
C11	1-135-145-11	TANTALUM CHIP 0.47uF	10% 35V
C12	1-164-222-11	CERAMIC CHIP 0.22uF	25V
C13	1-165-319-11	CERAMIC CHIP 0.1uF	50V
C14	1-162-568-11	CERAMIC CHIP 0.33uF	10% 16V
C15	1-104-562-11	FILM CHIP 0.082uF	5% 16V
C16	1-135-145-11	TANTALUM CHIP 0.47uF	10% 35V
C17	1-165-319-11	CERAMIC CHIP 0.1uF	50V
C18	1-164-222-11	CERAMIC CHIP 0.22uF	25V
C19	1-163-035-00	CERAMIC CHIP 0.047uF	50V
C20	1-104-553-11	FILM CHIP 0.015uF	5% 16V
C21	1-164-717-11	CERAMIC CHIP 0.0082uF	5% 50V
C22	1-163-009-11	CERAMIC CHIP 0.001uF	10% 50V
C23	1-164-161-11	CERAMIC CHIP 0.0022uF	10% 100V
C24	1-163-005-11	CERAMIC CHIP 470PF	10% 50V
C25	1-163-012-00	CERAMIC CHIP 0.0018uF	10% 50V
C26	1-104-558-11	FILM CHIP 0.039uF	5% 16V
C27	1-163-012-00	CERAMIC CHIP 0.0018uF	10% 50V
C28	1-163-012-00	CERAMIC CHIP 0.0018uF	10% 50V
C29	1-104-563-11	FILM CHIP 0.1uF	5% 16V
C30	1-135-145-11	TANTALUM CHIP 0.47uF	10% 35V
C31	1-104-555-11	FILM CHIP 0.022uF	5% 16V
C32	1-104-563-11	FILM CHIP 0.1uF	5% 16V

Ref.No.	Part No.	Description	Remark
C33	1-163-024-00	CERAMIC CHIP 0.018uF	10% 50V
C34	1-104-563-11	FILM CHIP 0.1uF	5% 16V
C35	1-163-012-00	CERAMIC CHIP 0.0018uF	10% 50V
C36	1-165-319-11	CERAMIC CHIP 0.1uF	50V
C37	1-164-222-11	CERAMIC CHIP 0.22uF	25V
C38	1-163-024-00	CERAMIC CHIP 0.018uF	10% 50V
C39	1-104-555-11	FILM CHIP 0.022uF	5% 16V
C40	1-104-563-11	FILM CHIP 0.1uF	5% 16V
		< CONNECTOR >	
CN1	1-695-092-11	SOCKET, CONNECTOR 7P	
		< IC >	
IC1	8-752-056-51	IC CXA1417Q	
		< RESISTOR >	
R1	1-216-615-11	METAL CHIP 33 0.5%	1/10W
R2	1-208-806-11	METAL GLAZE 10K 2%	1/10W
R3	1-208-812-11	METAL GLAZE 18K 2%	1/10W
R4	1-216-119-00	METAL CHIP 820K 5%	1/10W
R5	1-208-799-11	METAL GLAZE 5.1K 2%	1/10W
R6	1-208-787-11	METAL GLAZE 1.6K 2%	1/10W
R7	1-216-657-11	METAL CHIP 1.8K 0.5%	1/10W
R8	1-216-667-11	METAL CHIP 4.7K 0.5%	1/10W
R9	1-208-791-11	METAL GLAZE 2.4K 2%	1/10W
R10	1-216-052-00	METAL CHIP 1.3K 5%	1/10W
R11	1-216-615-11	METAL CHIP 33 0.5%	1/10W
R12	1-216-619-11	METAL CHIP 47 0.5%	1/10W
R13	1-208-784-11	METAL GLAZE 1.2K 2%	1/10W
R14	1-216-667-11	METAL CHIP 4.7K 0.5%	1/10W
R15	1-208-791-11	METAL GLAZE 2.4K 2%	1/10W
R16	1-216-615-11	METAL CHIP 33 0.5%	1/10W
R17	1-216-619-11	METAL CHIP 47 0.5%	1/10W
R18	1-216-657-11	METAL CHIP 1.8K 0.5%	1/10W
R19	1-208-787-11	METAL GLAZE 1.6K 2%	1/10W
R20	1-208-799-11	METAL GLAZE 5.1K 2%	1/10W
R21	1-216-119-00	METAL CHIP 820K 5%	1/10W
R22	1-216-655-11	METAL CHIP 1.5K 0.5%	1/10W
R23	1-216-678-11	METAL CHIP 13K 0.5%	1/10W
R24	1-216-673-11	METAL CHIP 8.2K 0.5%	1/10W
R25	1-208-806-11	METAL GLAZE 10K 2%	1/10W
R26	1-216-676-11	METAL CHIP 11K 0.5%	1/10W
R27	1-208-799-11	METAL GLAZE 5.1K 2%	1/10W
R28	1-216-695-11	METAL CHIP 68K 0.5%	1/10W
R29	1-208-799-11	METAL GLAZE 5.1K 2%	1/10W
R30	1-208-791-11	METAL GLAZE 2.4K 2%	1/10W
R31	1-208-811-11	METAL GLAZE 16K 2%	1/10W
R32	1-216-685-11	METAL CHIP 27K 0.5%	1/10W

DOLBY (S)

LEAF SW (DECK A)

LEAF SW (DECK B)

SYSTEM CONTROL

TRANSFORMER

PANEL

CONNECTOR

POWER SWITCH

PITCH CONTROL

HEADPHONE

Ref.No.	Part No.	Description	Remark		
R33	1-208-813-11	METAL GLAZE	20K	2%	1/10W
R34	1-216-684-11	METAL CHIP	24K	0.5%	1/10W
R35	1-208-817-11	METAL GLAZE	30K	2%	1/10W
R36	1-208-817-11	METAL GLAZE	30K	2%	1/10W
R37	1-216-676-11	METAL CHIP	11K	0.5%	1/10W
R38	1-208-819-11	METAL GLAZE	36K	2%	1/10W
R39	1-208-799-11	METAL GLAZE	5.1K	2%	1/10W
R40	1-208-817-11	METAL GLAZE	30K	2%	1/10W
R41	1-208-811-11	METAL GLAZE	16K	2%	1/10W
R42	1-216-673-11	METAL CHIP	8.2K	0.5%	1/10W
R43	1-216-676-11	METAL CHIP	11K	0.5%	1/10W
R44	1-216-689-11	METAL CHIP	39K	0.5%	1/10W
R45	1-216-689-11	METAL CHIP	39K	0.5%	1/10W

*	1-638-020-11	LEAF SW BOARD (DECK A)	*****		
		< CONNECTOR >			
* CNP81	1-568-850-11	SOCKET, CONNECTOR 7P			
		< IC >			
IC81	8-749-924-10	IC PHONT REFLECTOR NJL5165K-B (H1)			
		< RESISTOR >			
R84	1-249-417-11	CARBON	1K	5%	1/4W
R85	1-249-408-11	CARBON	180	5%	1/4W
		< SWITCH >			
S81	1-571-958-11	SWITCH, PUSH (1 KEY) (STOP DET)			
S82	1-571-281-21	SWITCH, LEAF (CrO ₂ DET)			
S86	1-571-281-21	SWITCH, LEAF (HALF DET)			

*	1-638-020-11	LEAF SW BOARD (DECK B)	*****		
		< CONNECTOR >			
* CNP81	1-568-850-11	SOCKET, CONNECTOR 7P			
		< IC >			
IC81	8-749-924-10	IC PHONT REFLECTOR NJL5165K-B (H1)			
		< RESISTOR >			
R81	1-249-414-11	CARBON	560	5%	1/4W
R82	1-247-818-11	CARBON	300	5%	1/4W
R83	1-247-834-11	CARBON	1.3K	5%	1/4W
R84	1-249-417-11	CARBON	1K	5%	1/4W
R85	1-249-408-11	CARBON	180	5%	1/4W

Ref.No.	Part No.	Description	Remark		
< SWITCH >					
S81	1-571-958-11	SWITCH, PUSH (1 KEY) (STOP DET)			
S82	1-571-281-21	SWITCH, LEAF (CrO ₂ DET)			
S83	1-571-281-21	SWITCH, LEAF (METAL DET)			
S84	1-571-281-21	SWITCH, LEAF (ERASE PROOF, SIDE A)			
S85	1-571-281-21	SWITCH, LEAF (ERASE PROOF, SIDE B)			
S86	1-571-281-21	SWITCH, LEAF (HALF DET)			

*	A-2007-311-A	SYSTEM CONTROL BOARD, COMPLETE (WR565:US, CND, AEP, UK, G, CH)			
*	A-2007-365-A	SYSTEM CONTROL BOARD, COMPLETE (WA7ES)			
*	A-2007-313-A	SYSTEM CONTROL BOARD, COMPLETE (WR565:AUS)			
*	A-2007-314-A	SYSTEM CONTROL BOARD, COMPLETE (WR565:E)			
*	A-2007-317-A	SYSTEM CONTROL BOARD, COMPLETE (WR665S:AUS)			
*	A-2007-318-A	SYSTEM CONTROL BOARD, COMPLETE (WR665S:E)			
*	A-2007-315-A	SYSTEM CONTROL BOARD, COMPLETE (WR665S:US, CND, AEP, UK, G, CH)			

TRANSFORMER BOARD					

PANEL BOARD					

CONNECTOR BOARD					

POWER SWITCH BOARD					

PITCH CONTROL BOARD (WR565, WR665S)					

HEADPHONE BOARD					

< CAPACITOR >					
C101	1-162-302-11	CERAMIC	0.0022uF	30%	16V
C102	1-124-907-11	ELECT	10uF	20%	50V
C103	1-124-907-11	ELECT	10uF	20%	50V
C104	1-137-368-11	FILM	0.0047uF	5%	50V
C105	1-136-165-00	FILM	0.1uF	5%	50V
C106	1-136-163-00	FILM	0.068uF	5%	50V
C107	1-124-907-11	ELECT	10uF	20%	50V
C108	1-124-925-11	ELECT	2.2uF	20%	100V
C109	1-162-282-31	CERAMIC	100PF	10%	50V
C110	1-124-925-11	ELECT	2.2uF	20%	100V

SYSTEM CONTROL

TRANSFORMER

PANEL

CONNECTOR

POWER SWITCH

PITCH CONTROL

HEADPHONE

Ref. No.	Part No.	Description	Remark
C111	1-124-927-11	ELECT 4.7uF 20%	100V
C112	1-124-925-11	ELECT 2.2uF 20%	100V
C113	1-124-907-11	ELECT 10uF 20%	50V
C114	1-124-916-11	ELECT 22uF 20%	63V (WA7ES, WR665S)
C115	1-124-927-11	ELECT 4.7uF 20%	100V
C116	1-137-342-11	FILM 0.0039uF 50%	50V
C121	1-124-927-11	ELECT 4.7uF 20%	100V
C122	1-124-902-00	ELECT 0.47uF 20%	50V
C123	1-164-159-11	CERAMIC 0.1uF	50V
C124	1-124-927-11	ELECT 4.7uF 20%	100V
C125	1-126-962-11	ELECT 3.3uF 20%	50V
C141	1-124-907-11	ELECT 10uF 20%	50V
C201	1-162-302-11	CERAMIC 0.0022uF	30% 16V
C202	1-124-907-11	ELECT 10uF 20%	50V
C203	1-124-907-11	ELECT 10uF 20%	50V
C204	1-137-368-11	FILM 0.0047uF 5%	50V
C205	1-136-165-00	FILM 0.1uF 5%	50V
C206	1-136-163-00	FILM 0.068uF 5%	50V
C207	1-124-907-11	ELECT 10uF 20%	50V
C208	1-124-925-11	ELECT 2.2uF 20%	100V
C209	1-162-282-31	CERAMIC 100PF	10% 50V
C210	1-124-925-11	ELECT 2.2uF 20%	100V
C211	1-124-927-11	ELECT 4.7uF 20%	100V
C212	1-124-925-11	ELECT 2.2uF 20%	100V
C213	1-124-907-11	ELECT 10uF 20%	50V (WA7ES, WR665S)
C214	1-124-916-11	ELECT 22uF 20%	63V (WA7ES, WR665S)
C215	1-124-927-11	ELECT 4.7uF 20%	100V
C216	1-137-342-11	FILM 0.0039uF 50%	50V
C221	1-124-927-11	ELECT 4.7uF 20%	100V
C222	1-124-902-00	ELECT 0.47uF 20%	50V
C223	1-164-159-11	CERAMIC 0.1uF	50V
C224	1-124-927-11	ELECT 4.7uF 20%	100V
C225	1-126-962-11	ELECT 3.3uF 20%	50V
C241	1-124-907-11	ELECT 10uF 20%	50V
C501	1-124-907-11	ELECT 10uF 20%	50V
C502	1-126-176-11	ELECT 220uF 20%	10V
C503	1-161-494-00	CERAMIC 0.022uF	25V
C521	1-124-443-00	ELECT 100uF 20%	10V
C522	1-124-443-00	ELECT 100uF 20%	10V
C523	1-124-443-00	ELECT 100uF 20%	10V
C524	1-124-902-00	ELECT 0.47uF 20%	50V
C525	1-124-925-11	ELECT 2.2uF 20%	100V
C526	1-124-916-11	ELECT 22uF 20%	63V
C527	1-126-916-11	ELECT 1000uF 20%	6.3V
C528	1-124-902-00	ELECT 0.47uF 20%	50V

Ref. No.	Part No.	Description	Remark
C529	1-124-443-00	ELECT 100uF 20%	10V
C541	1-130-494-11	MYLAR 0.082uF 5%	50V
C542	1-137-457-11	FILM 0.0027uF 5%	50V
C543	1-136-161-00	FILM 0.047uF 5%	50V
C544	1-137-366-11	FILM 0.0022uF 5%	50V
C545	1-124-907-11	ELECT 10uF 20%	50V (WA7ES, WR665S)
C546	1-124-907-11	ELECT 10uF 20%	50V (WA7ES, WR665S)
C551	1-161-494-00	CERAMIC 0.022uF	25V
C701	1-124-927-11	ELECT 4.7uF 20%	100V
C702	1-126-016-11	ELECT 4700uF 20%	16V (WA7ES)
C702	1-124-898-11	ELECT 4700uF 20%	16V (WR565, WR665S)
C703	1-126-016-11	ELECT 4700uF 20%	16V (WA7ES)
C703	1-124-898-11	ELECT 4700uF 20%	16V (WR565, WR665S)
C704	1-124-927-11	ELECT 4.7uF 20%	100V
C705	1-124-472-11	ELECT 470uF 20%	10V
C706	1-124-927-11	ELECT 4.7uF 20%	100V
C707	1-124-762-00	ELECT 4700uF 20%	10V
C708	1-126-926-11	ELECT 1000uF 20%	10V (WR565, WR665S)
C708	1-124-473-11	ELECT 1000uF 20%	10V (WA7ES)
C709	1-124-910-11	ELECT 47uF 20%	50V
C710	1-124-907-11	ELECT 10uF 20%	50V
C711	1-124-927-11	ELECT 4.7uF 20%	100V
C801	1-164-159-11	CERAMIC 0.1uF	50V
C802	1-124-902-00	ELECT 0.47uF 20%	50V
C803	1-124-443-00	ELECT 100uF 20%	10V
C804	1-164-159-11	CERAMIC 0.1uF	50V
C805	1-164-159-11	CERAMIC 0.1uF	50V
C810	1-162-288-31	CERAMIC 330PF	10% 50V
C811	1-164-159-11	CERAMIC 0.1uF	50V
C812	1-162-288-31	CERAMIC 330PF	10% 50V
C813	1-164-159-11	CERAMIC 0.1uF	50V
C814	1-124-907-11	ELECT 10uF 20%	50V
C815	1-124-902-00	ELECT 0.47uF 20%	50V
C816	1-126-103-11	ELECT 470uF 20%	16V
C817	1-126-103-11	ELECT 470uF 20%	16V
C818	1-124-360-00	ELECT 1000uF 20%	16V
C901	1-161-494-00	CERAMIC 0.022uF	25V (PANEL BOARD)
C902	1-161-494-00	CERAMIC 0.022uF	25V (PANEL BOARD)
C903	1-161-494-00	CERAMIC 0.022uF	25V (PANEL BOARD)
C904	1-161-494-00	CERAMIC 0.022uF	25V (PANEL BOARD)

SYSTEM CONTROL

TRANSFORMER

PANEL

CONNECTOR

POWER SWITCH

PITCH CONTROL

HEADPHONE

Ref. No.	Part No.	Description	Remark
C905	1-161-494-00	CERAMIC 0.022uF	25V (PANEL BOARD)
< CONNECTOR >			
CN131	1-695-087-11	PIN, CONNECTOR (PC BOARD) 7P	(WATES, WR665S)
CN231	1-695-087-11	PIN, CONNECTOR (PC BOARD) 7P	(WATES, WR665S)
* CN502	1-568-826-11	SOCKET, CONNECTOR 7P	
* CN801	1-764-700-11	SOCKET, CONNECTOR 37P	
* CN802	1-568-826-11	SOCKET, CONNECTOR 7P	
* CN803	1-568-826-11	SOCKET, CONNECTOR 7P	
* CN804	1-568-830-11	SOCKET, CONNECTOR 11P	
* CN805	1-568-830-11	SOCKET, CONNECTOR 11P (CONNECTOR BOARD)	
* CN810	1-568-951-11	PIN, CONNECTOR 2P (CONNECTOR BOARD)	
* CN901	1-764-701-11	SOCKET, CONNECTOR 37P (PANEL BOARD)	
* CN902	1-568-850-11	SOCKET, CONNECTOR 7P (PANEL BOARD)	
* CN906	1-564-495-11	PIN, CONNECTOR 2P (WR565, WR665S)	
< CONNECTOR >			
CNP501	1-506-468-11	PIN, CONNECTOR 3P	
CNP701	1-766-280-11	PIN, CONNECTOR (PC BOARD) 7P	
* CNP702	1-568-954-11	PIN, CONNECTOR 5P	
* CNP703	1-580-230-31	PIN, CONNECTOR (PC BOARD) 2P	(TRANSFORMER BOARD) (EXCEPT E)
CNP704	1-766-280-11	PIN, CONNECTOR (PC BOARD) 7P	(TRANSFORMER BOARD)
* CNP801	1-691-916-11	CONNECTOR, BOARD TO BOARD	(CONNECTOR BOARD)
* CNP802	1-691-916-11	CONNECTOR, BOARD TO BOARD	
* CNP803	1-691-916-11	CONNECTOR, BOARD TO BOARD	
< DIODE >			
D121	8-719-933-33	DIODE HZS6A1L	
D221	8-719-933-33	DIODE HZS6A1L	
D501	8-719-987-63	DIODE 1N4148M	
D502	8-719-987-63	DIODE 1N4148M	
D503	8-719-107-94	DIODE 1SS202-1 (WATES, WR665S)	
D504	8-719-107-94	DIODE 1SS202-1 (WATES, WR665S)	
D505	8-719-107-94	DIODE 1SS202-1 (WATES, WR665S)	
D506	8-719-107-94	DIODE 1SS202-1 (WATES, WR665S)	
D521	8-719-987-63	DIODE 1N4148M	
D531	8-719-987-63	DIODE 1N4148M	
D541	8-719-987-63	DIODE 1N4148M	
D542	8-719-987-63	DIODE 1N4148M	
D701	8-719-024-99	DIODE 11ES2-NTA2B	
D702	8-719-024-99	DIODE 11ES2-NTA2B	
D703	8-719-024-99	DIODE 11ES2-NTA2B	
D704	8-719-024-99	DIODE 11ES2-NTA2B	

Ref. No.	Part No.	Description	Remark
D705	8-719-024-99	DIODE 11ES2-NTA2B	
D706	8-719-024-99	DIODE 11ES2-NTA2B	
D707	8-719-024-99	DIODE 11ES2-NTA2B	
D708	8-719-987-63	DIODE 1N4148M	
D709	8-719-000-78	DIODE UZL-7L2	
D710	8-719-933-33	DIODE HZS6A1L	
D711	8-719-933-33	DIODE HZS6A1L	
D712	8-719-987-63	DIODE 1N4148M	
D713	8-719-987-63	DIODE 1N4148M	
D714	8-719-000-78	DIODE UZL-7L2	
D715	8-719-933-33	DIODE HZS6A1L	
D801	8-719-987-63	DIODE 1N4148M	
D802	8-719-987-63	DIODE 1N4148M	
D803	8-719-987-63	DIODE 1N4148M	
D804	8-719-987-63	DIODE 1N4148M	
D805	8-719-987-63	DIODE 1N4148M (WR565, WR665S)	
D806	8-719-987-63	DIODE 1N4148M (WR565, WR665S)	
D807	8-719-987-63	DIODE 1N4148M	
< IC >			
IC501	8-752-066-35	IC CXA1563S	
IC502	8-759-634-51	IC M5218AP	
IC503	8-759-634-50	IC M5218AL	
IC504	8-759-634-50	IC M5218AL	
IC521	8-752-058-57	IC CXA1599Q	
IC541	8-759-634-51	IC M5218AP	
IC701	8-759-634-51	IC M5218AP	
IC801	8-752-862-32	IC CXP82316-053Q	
IC802	8-759-000-48	IC MC14052BCP	
IC803	8-759-822-38	IC LA6510	
IC804	8-759-916-14	IC SN74HC04AN	
IC805	8-759-000-48	IC MC14052BCP	
IC806	8-759-165-82	IC PST600E-T	
IC901	8-741-810-59	IC SBX1610-59 (PANEL BOARD)	
< JACK >			
J501	1-565-258-11	JACK, PIN 4P (LINE IN/OUT)	
J502	1-568-519-41	JACK, LARGE TYPE (PHONES)	(HEADPHONE BOARD)
< COIL >			
L801	1-420-872-00	COIL, AIR-CORE	
L802	1-420-872-00	COIL, AIR-CORE	
< FILTER >			
LPF101	1-233-271-11	FILTER, LOW PASS	
LPF201	1-233-271-11	FILTER, LOW PASS	

SYSTEM CONTROL

TRANSFORMER

PANEL

CONNECTOR

POWER SWITCH

PITCH CONTROL

HEADPHONE

Ref. No.	Part No.	Description	Remark
		< TRANSISTOR >	
Q101	8-729-900-74	TRANSISTOR DTC143TS	
Q102	8-729-900-74	TRANSISTOR DTC143TS	
Q121	8-729-922-37	TRANSISTOR 2SD2144S	
Q122	8-729-620-05	TRANSISTOR 2SC2603-EF	
Q201	8-729-900-74	TRANSISTOR DTC143TS	
Q202	8-729-900-74	TRANSISTOR DTC143TS	
Q221	8-729-922-37	TRANSISTOR 2SD2144S	
Q222	8-729-620-05	TRANSISTOR 2SC2603-EF	
Q501	8-729-900-65	TRANSISTOR DTA144ES	
Q502	8-729-900-65	TRANSISTOR DTA144ES	
Q503	8-729-900-65	TRANSISTOR DTA144ES	
Q504	8-729-900-65	TRANSISTOR DTA144ES	
Q505	8-729-900-65	TRANSISTOR DTA144ES	
Q521	8-729-119-76	TRANSISTOR 2SA1175-HFE	
Q522	8-729-119-76	TRANSISTOR 2SA1175-HFE	
Q523	8-729-620-05	TRANSISTOR 2SC2603-EF	
Q525	8-729-900-89	TRANSISTOR DTC144ES	
Q526	8-729-900-65	TRANSISTOR DTA144ES	
Q527	8-729-900-89	TRANSISTOR DTC144ES	
Q541	8-729-900-89	TRANSISTOR DTC144ES	
Q542	8-729-620-05	TRANSISTOR 2SC2603-EF	
Q701	8-729-620-05	TRANSISTOR 2SC2603-EF	
Q702	8-729-209-15	TRANSISTOR 2SD2012	
Q703	8-729-900-74	TRANSISTOR DTC143TS	
Q704	8-729-900-74	TRANSISTOR DTC143TS	
Q705	8-729-141-83	TRANSISTOR 2SB1094-LK	
Q706	8-729-209-15	TRANSISTOR 2SD2012	
Q707	8-729-119-76	TRANSISTOR 2SA1175-HFE	
Q708	8-729-140-04	TRANSISTOR 2SB1116A-L	
Q801	8-729-900-80	TRANSISTOR DTC114ES	
Q802	8-729-620-05	TRANSISTOR 2SC2603-EF	
Q803	8-729-900-89	TRANSISTOR DTC144ES	
Q804	8-729-900-80	TRANSISTOR DTC114ES	
Q805	8-729-801-93	TRANSISTOR 2SD1387	
Q806	8-729-801-93	TRANSISTOR 2SD1387	
Q807	8-729-900-89	TRANSISTOR DTC144ES	
Q808	8-729-900-65	TRANSISTOR DTA144ES	
Q809	8-729-119-76	TRANSISTOR 2SA1175-HFE	
Q810	8-729-900-80	TRANSISTOR DTC114ES (WR565, WR665S)	
Q811	8-729-900-65	TRANSISTOR DTA144ES (WA7ES, WR665S)	
Q812	8-729-900-80	TRANSISTOR DTC114ES	
Q813	8-729-900-65	TRANSISTOR DTA144ES (WR565, WR665S)	
Q920	8-729-119-76	TRANSISTOR 2SA1175-HFE	
		(CONNECTOR BOARD) (WR565, WR665S)	
		< RESISTOR >	
R101	1-249-432-11	CARBON 18K 5% 1/4W	

Ref. No.	Part No.	Description	Remark
R102	1-249-421-11	CARBON 2.2K 5% 1/4W	
R103	1-249-420-11	CARBON 1.8K 5% 1/4W	
R104	1-249-441-11	CARBON 100K 5% 1/4W	
R105	1-249-424-11	CARBON 3.9K 5% 1/4W	
R109	1-249-429-11	CARBON 10K 5% 1/4W	
R110	1-249-429-11	CARBON 10K 5% 1/4W	
R111	1-249-435-11	CARBON 33K 5% 1/4W	
R112	1-247-846-11	CARBON 4.3K 5% 1/4W	
R113	1-247-887-00	CARBON 220K 5% 1/4W	
R114	1-249-429-11	CARBON 10K 5% 1/4W	
R115	1-249-433-11	CARBON 22K 5% 1/4W	
R117	1-249-437-11	CARBON 47K 5% 1/4W	
R118	1-249-425-11	CARBON 4.7K 5% 1/4W	
R119	1-249-429-11	CARBON 10K 5% 1/4W	
R121	1-249-434-11	CARBON 27K 5% 1/4W	
R122	1-249-417-11	CARBON 1K 5% 1/4W	
R123	1-249-421-11	CARBON 2.2K 5% 1/4W	
R124	1-247-887-00	CARBON 220K 5% 1/4W	
R125	1-249-421-11	CARBON 2.2K 5% 1/4W	
R126	1-247-807-31	CARBON 100 5% 1/4W	
R127	1-247-807-31	CARBON 100 5% 1/4W	
R128	1-249-421-11	CARBON 2.2K 5% 1/4W	
R129	1-249-439-11	CARBON 68K 5% 1/4W	
R131	1-249-437-11	CARBON 47K 5% 1/4W	
R132	1-249-409-11	CARBON 220 5% 1/4W	
R141	1-249-441-11	CARBON 100K 5% 1/4W	
R142	1-249-435-11	CARBON 33K 5% 1/4W	
R201	1-249-432-11	CARBON 18K 5% 1/4W	
R202	1-249-421-11	CARBON 2.2K 5% 1/4W	
R203	1-249-420-11	CARBON 1.8K 5% 1/4W	
R204	1-249-441-11	CARBON 100K 5% 1/4W	
R205	1-249-424-11	CARBON 3.9K 5% 1/4W	
R209	1-249-429-11	CARBON 10K 5% 1/4W	
R210	1-249-429-11	CARBON 10K 5% 1/4W	
R211	1-249-435-11	CARBON 33K 5% 1/4W	
R212	1-247-846-11	CARBON 4.3K 5% 1/4W	
R213	1-247-887-00	CARBON 220K 5% 1/4W	
R214	1-249-429-11	CARBON 10K 5% 1/4W	
R215	1-249-433-11	CARBON 22K 5% 1/4W	
R217	1-249-437-11	CARBON 47K 5% 1/4W	
R218	1-249-425-11	CARBON 4.7K 5% 1/4W	
R219	1-249-429-11	CARBON 10K 5% 1/4W	
R221	1-249-434-11	CARBON 27K 5% 1/4W	
R222	1-249-417-11	CARBON 1K 5% 1/4W	
R223	1-249-421-11	CARBON 2.2K 5% 1/4W	
R224	1-247-887-00	CARBON 220K 5% 1/4W	
R225	1-249-421-11	CARBON 2.2K 5% 1/4W	
R226	1-247-807-31	CARBON 100 5% 1/4W	
R227	1-247-807-31	CARBON 100 5% 1/4W	

SYSTEM CONTROL

TRANSFORMER

PANEL

CONNECTOR

POWER SWITCH

PITCH CONTROL

HEADPHONE

Ref. No.	Part No.	Description	Remark	Ref. No.	Part No.	Description	Remark
R228	1-249-421-11	CARBON 2. 2K 5%	1/4W	R713	1-249-417-11	CARBON 1K 5%	1/4W
R229	1-249-439-11	CARBON 68K 5%	1/4W	R714	1-249-422-11	CARBON 2. 7K 5%	1/4W
R231	1-249-437-11	CARBON 47K 5%	1/4W	R715	1-249-431-11	CARBON 15K 5%	1/4W
R232	1-249-409-11	CARBON 220 5%	1/4W	R716	1-249-430-11	CARBON 12K 5%	1/4W
R241	1-249-441-11	CARBON 100K 5%	1/4W	R717	1-249-437-11	CARBON 47K 5%	1/4W
R242	1-249-435-11	CARBON 33K 5%	1/4W	△R718	1-219-137-11	FUSIBLE 0. 33 10%	1/4W F
R501	1-215-452-00	METAL 20K 1%	1/4W	R719	1-249-414-11	CARBON 560 5%	1/4W
R502	1-249-417-11	CARBON 1K 5%	1/4W	△R720	1-219-139-11	FUSIBLE 0. 68 10%	1/4W F
R503	1-249-435-11	CARBON 33K 5%	1/4W	△R721	1-219-139-11	FUSIBLE 0. 68 10%	1/4W F
R505	1-249-435-11	CARBON 33K 5%	1/4W	R801	1-249-417-11	CARBON 1K 5%	1/4W
R506	1-249-433-11	CARBON 22K 5%	1/4W	R802	1-249-441-11	CARBON 100K 5%	1/4W
R508	1-249-433-11	CARBON 22K 5%	1/4W	R803	1-249-435-11	CARBON 33K 5%	1/4W
R509	1-249-435-11	CARBON 33K 5%	1/4W	R804	1-249-433-11	CARBON 22K 5%	1/4W
R521	1-215-455-00	METAL 27K 1%	1/4W	R805	1-249-433-11	CARBON 22K 5%	1/4W
R522	1-249-429-11	CARBON 10K 5%	1/4W	R806	1-249-429-11	CARBON 10K 5%	1/4W
R523	1-249-429-11	CARBON 10K 5%	1/4W	R807	1-249-429-11	CARBON 10K 5%	1/4W
R524	1-249-417-11	CARBON 1K 5%	1/4W	R808	1-249-433-11	CARBON 22K 5%	1/4W
R525	1-247-872-11	CARBON 51K 5%	1/4W	R809	1-249-430-11	CARBON 12K 5%	1/4W
R526	1-249-417-11	CARBON 1K 5%	1/4W	R810	1-249-433-11	CARBON 22K 5%	1/4W
R527	1-249-413-11	CARBON 470 5%	1/4W	R811	1-249-433-11	CARBON 22K 5%	1/4W
△R528	1-212-863-00	FUSIBLE 18 5%	1/4W F	R812	1-249-433-11	CARBON 22K 5%	1/4W
R529	1-249-437-11	CARBON 47K 5%	1/4W	R813	1-247-807-31	CARBON 100 5%	1/4W
R530	1-249-429-11	CARBON 10K 5%	1/4W	R814	1-249-430-11	CARBON 12K 5%	1/4W
R531	1-249-437-11	CARBON 47K 5%	1/4W	R815	1-249-433-11	CARBON 22K 5%	1/4W
R532	1-249-417-11	CARBON 1K 5%	1/4W	R816	1-249-433-11	CARBON 22K 5%	1/4W
R533	1-249-432-11	CARBON 18K 5%	1/4W	R817	1-249-433-11	CARBON 22K 5%	1/4W
R534	1-249-430-11	CARBON 12K 5%	1/4W	R818	1-247-807-31	CARBON 100 5%	1/4W
R535	1-249-437-11	CARBON 47K 5%	1/4W	R819	1-249-434-11	CARBON 27K 5%	1/4W
R536	1-249-437-11	CARBON 47K 5%	1/4W	R820	1-249-434-11	CARBON 27K 5%	1/4W
R538	1-249-435-11	CARBON 33K 5%	1/4W	R821	1-249-434-11	CARBON 27K 5%	1/4W
R541	1-249-426-11	CARBON 5. 6K 5%	1/4W	R822	1-249-434-11	CARBON 27K 5%	1/4W
R542	1-249-433-11	CARBON 22K 5%	1/4W	R823	1-249-429-11	CARBON 10K 5%	1/4W
R543	1-249-436-11	CARBON 39K 5%	1/4W	R824	1-249-429-11	CARBON 10K 5%	1/4W
R544	1-249-441-11	CARBON 100K 5%	1/4W	R825	1-249-429-11	CARBON 10K 5%	1/4W
R545	1-249-437-11	CARBON 47K 5%	1/4W	R826	1-249-429-11	CARBON 10K 5%	1/4W
R546	1-249-441-11	CARBON 100K 5%	1/4W	R827	1-249-421-11	CARBON 2. 2K 5%	1/4W
R547	1-247-846-11	CARBON 4. 3K 5%	1/4W	R828	1-247-874-11	CARBON 62K 5%	1/4W
R701	1-249-421-11	CARBON 2. 2K 5%	1/4W	R829	1-247-866-11	CARBON 30K 5%	1/4W
R702	1-249-422-11	CARBON 2. 7K 5%	1/4W	R830	1-249-431-11	CARBON 15K 5%	1/4W
R703	1-249-429-11	CARBON 10K 5%	1/4W	R831	1-247-852-11	CARBON 7. 5K 5%	1/4W
R704	1-249-422-11	CARBON 2. 7K 5%	1/4W	R835	1-249-433-11	CARBON 22K 5%	1/4W
R705	1-249-425-11	CARBON 4. 7K 5%	1/4W	R836	1-247-852-11	CARBON 7. 5K 5%	1/4W
R706	1-249-427-11	CARBON 6. 8K 5%	1/4W	R841	1-249-421-11	CARBON 2. 2K 5%	1/4W
R707	1-249-419-11	CARBON 1. 5K 5%	1/4W	R842	1-249-429-11	CARBON 10K 5%	1/4W
R708	1-249-429-11	CARBON 10K 5%	1/4W	R843	1-249-421-11	CARBON 2. 2K 5%	1/4W
R709	1-249-419-11	CARBON 1. 5K 5%	1/4W	R844	1-249-429-11	CARBON 10K 5%	1/4W
R710	1-249-425-11	CARBON 4. 7K 5%	1/4W	R845	1-249-422-11	CARBON 2. 7K 5%	1/4W
R711	1-249-427-11	CARBON 6. 8K 5%	1/4W	R846	1-249-422-11	CARBON 2. 7K 5%	1/4W
R712	1-249-427-11	CARBON 6. 8K 5%	1/4W	R847	1-249-422-11	CARBON 2. 7K 5%	1/4W

The components identified by mark Δ or dotted line with mark Δ are critical for safety. Replace only with part number specified.

Les composants identifiés par une marque Δ sont critiques pour la sécurité. Ne les remplacer que par une pièce portant le numéro spécifié.

SYSTEM CONTROL

TRANSFORMER

PANEL

CONNECTOR

POWER SWITCH

PITCH CONTROL

HEADPHONE

Ref. No.	Part No.	Description	Remark
R848	1-249-434-11	CARBON 27K 5%	1/4W
R849	1-249-421-11	CARBON 2.2K 5%	1/4W
R850	1-249-421-11	CARBON 2.2K 5%	1/4W
R851	1-249-421-11	CARBON 2.2K 5%	1/4W
R852	1-249-434-11	CARBON 27K 5%	1/4W
R853	1-249-421-11	CARBON 2.2K 5%	1/4W
R854	1-249-421-11	CARBON 2.2K 5%	1/4W
R855	1-249-433-11	CARBON 22K 5%	1/4W
R856	1-247-807-31	CARBON 100 5%	1/4W
R857	1-247-807-31	CARBON 100 5%	1/4W
R858	1-247-807-31	CARBON 100 5%	1/4W
R859	1-247-807-31	CARBON 100 5%	1/4W
R860	1-247-807-31	CARBON 100 5%	1/4W
R861	1-249-441-11	CARBON 100K 5%	1/4W
R862	1-249-422-11	CARBON 2.7K 5%	1/4W
R863	1-249-426-11	CARBON 5.6K 5%	1/4W
R864	1-247-852-11	CARBON 7.5K 5%	1/4W
R865	1-247-858-11	CARBON 13K 5%	1/4W
R866	1-249-429-11	CARBON 10K 5%	1/4W
R867	1-247-840-00	CARBON 2.4K 5%	1/4W
R868	1-247-852-11	CARBON 7.5K 5%	1/4W
R869	1-249-425-11	CARBON 4.7K 5%	1/4W
R870	1-249-430-11	CARBON 12K 5%	1/4W
R871	1-249-430-11	CARBON 12K 5%	1/4W
R872	1-249-436-11	CARBON 39K 5%	1/4W
R873	1-249-437-11	CARBON 47K 5%	1/4W (CONNECTOR BOARD) (WR565, WR665S)
R874	1-249-437-11	CARBON 47K 5%	1/4W (CONNECTOR BOARD) (WR565, WR665S)
R875	1-247-848-11	CARBON 5.1K 5%	1/4W (CONNECTOR BOARD) (WR565, WR665S)
R876	1-249-435-11	CARBON 33K 5%	1/4W (WR565)
R877	1-249-435-11	CARBON 33K 5%	1/4W (WA7ES, WR665S)
R878	1-249-435-11	CARBON 33K 5%	1/4W (WR565)
R879	1-249-441-11	CARBON 100K 5%	1/4W (PITCH CONTROL BOARD) (WR565, WR665S)
R880	1-249-435-11	CARBON 33K 5%	1/4W (WA7ES)
R901	1-249-429-11	CARBON 10K 5%	1/4W (PANEL BOARD)
R902	1-249-429-11	CARBON 10K 5%	1/4W (PANEL BOARD)
R903	1-249-429-11	CARBON 10K 5%	1/4W (PANEL BOARD)
R904	1-249-429-11	CARBON 10K 5%	1/4W (PANEL BOARD)
R905	1-249-429-11	CARBON 10K 5%	1/4W (PANEL BOARD)
R906	1-249-418-11	CARBON 1.2K 5%	1/4W (PANEL BOARD)
R907	1-249-420-11	CARBON 1.8K 5%	1/4W (PANEL BOARD)
R908	1-249-422-11	CARBON 2.7K 5%	1/4W (PANEL BOARD)
R909	1-249-424-11	CARBON 3.9K 5%	1/4W (PANEL BOARD)
R910	1-249-427-11	CARBON 6.8K 5%	1/4W (PANEL BOARD)
R911	1-249-418-11	CARBON 1.2K 5%	1/4W (PANEL BOARD)
R912	1-249-420-11	CARBON 1.8K 5%	1/4W (PANEL BOARD)

Ref. No.	Part No.	Description	Remark
R913	1-249-422-11	CARBON 2.7K 5%	1/4W (PANEL BOARD)
R914	1-249-424-11	CARBON 3.9K 5%	1/4W (PANEL BOARD)
R915	1-249-427-11	CARBON 6.8K 5%	1/4W (PANEL BOARD)
R916	1-249-431-11	CARBON 15K 5%	1/4W (PANEL BOARD)
R917	1-249-418-11	CARBON 1.2K 5%	1/4W (PANEL BOARD)
R918	1-249-420-11	CARBON 1.8K 5%	1/4W (PANEL BOARD)
R919	1-249-422-11	CARBON 2.7K 5%	1/4W (PANEL BOARD)
R920	1-249-418-11	CARBON 1.2K 5%	1/4W (PANEL BOARD)
R921	1-249-420-11	CARBON 1.8K 5%	1/4W (PANEL BOARD)
R922	1-249-424-11	CARBON 3.9K 5%	1/4W (PANEL BOARD)
R923	1-249-418-11	CARBON 1.2K 5%	1/4W (PANEL BOARD)
R924	1-249-420-11	CARBON 1.8K 5%	1/4W (PANEL BOARD)
R925	1-249-422-11	CARBON 2.7K 5%	1/4W (PANEL BOARD) (WA7ES, WR665S)
R926	1-249-427-11	CARBON 6.8K 5%	1/4W (PANEL BOARD)
R927	1-249-427-11	CARBON 6.8K 5%	1/4W (PANEL BOARD)
R928	1-249-431-11	CARBON 15K 5%	1/4W (PANEL BOARD) (WA7ES, WR665S)
R929	1-249-424-11	CARBON 3.9K 5%	1/4W (PANEL BOARD)
R930	1-249-422-11	CARBON 2.7K 5%	1/4W (PANEL BOARD)
R931	1-249-424-11	CARBON 3.9K 5%	1/4W (PANEL BOARD) (WA7ES, WR665S)
R931	1-249-427-11	CARBON 6.8K 5%	1/4W (PANEL BOARD) (WR565)
< VARIABLE RESISTOR >			
RV101	1-241-630-11	RES, ADJ, CARBON 10K	(REC LEVEL, L)
RV201	1-241-630-11	RES, ADJ, CARBON 10K	(REC LEVEL, R)
RV801	1-223-848-11	RES, VAR, CARBON 50K	(PITCH CONTROL) (PITCH CONTROL BOARD) (WR565, WR665S)
RV802	1-241-765-11	RES, ADJ, CARBON 22K	(PITCH CONTROL) (CONTROL BOARD) (WR565, WR665S)
RV901	1-223-616-11	RES, VAR, CARBON 5K/5K	(BALANCE) (PANEL BOARD)
RV902	1-223-617-11	RES, VAR, CARBON 5K/5K	(REC LEVEL) (PANEL BOARD)
< SWITCH >			
S701	1-554-118-00	SWITCH, PUSH (1 KEY)	(POWER) (POWER SWITCH BOARD)
S901	1-554-303-21	SWITCH, TACTILE (■ CLEAR)	(PANEL BOARD)
S902	1-554-303-21	SWITCH, TACTILE (▷ FRONT)	(PANEL BOARD)
S903	1-554-303-21	SWITCH, TACTILE (◁ BACK)	(PANEL BOARD)
S904	1-554-303-21	SWITCH, TACTILE (AMS ◀)	(PANEL BOARD)
S905	1-554-303-21	SWITCH, TACTILE (AMS ▶)	(PANEL BOARD)
S906	1-554-303-21	SWITCH, TACTILE (● REC)	(PANEL BOARD)
S907	1-554-303-21	SWITCH, TACTILE (■)	(PANEL BOARD)
S908	1-554-303-21	SWITCH, TACTILE (▯ PAUSE)	(PANEL BOARD)
S909	1-554-303-21	SWITCH, TACTILE (▷)	(PANEL BOARD)
S910	1-554-303-21	SWITCH, TACTILE (◁)	(PANEL BOARD)

SYSTEM CONTROL

TRANSFORMER

PANEL

CONNECTOR

POWER SWITCH

PITCH CONTROL

HEADPHONE

Ref. No.	Part No.	Description	Remark
S911	1-554-303-21	SWITCH, TACTILE (● REC MUTE) (PANEL BOARD)	
S912	1-554-303-21	SWITCH, TACTILE (AMS ◀◀) (PANEL BOARD)	
S913	1-554-303-21	SWITCH, TACTILE (AMS ▶▶) (PANEL BOARD)	
S914	1-554-303-21	SWITCH, TACTILE (DISPLAY) (PANEL BOARD)	
S915	1-554-303-21	SWITCH, TACTILE (RMS/START) (PANEL BOARD)	
S916	1-554-303-21	SWITCH, TACTILE (SET) (PANEL BOARD)	
S917	1-554-303-21	SWITCH, TACTILE (CHECK) (PANEL BOARD)	
S918	1-554-303-21	SWITCH, TACTILE (COUNTER RESET) (PANEL BOARD) (WR565)	
S918	1-554-303-21	SWITCH, TACTILE (RESET) (PANEL BOARD) (WA7ES, WR665S)	
S919	1-554-303-21	SWITCH, TACTILE (MEMORY) (PANEL BOARD) (WA7ES, WR665S)	
S920	1-554-303-21	SWITCH, TACTILE (HIGH) (PANEL BOARD)	
S921	1-554-303-21	SWITCH, TACTILE (NORMAL) (PANEL BOARD)	
S922	1-554-303-21	SWITCH, TACTILE (RESET) (PANEL BOARD) (WA7ES, WR665S)	
S923	1-692-126-11	SWITCH, SLIDE (DOLBY NR) (PANEL BOARD) (WA7ES, WR665S)	
S923	1-692-665-11	SWITCH, SLIDE (DOLBY NR) (PANEL BOARD) (WR565)	
S924	1-692-126-11	SWITCH, SLIDE (DOLBY NR) (PANEL BOARD)	
S925	1-692-126-11	SWITCH, SLIDE (DIR MODE) (PANEL BOARD)	
S926	1-554-303-21	SWITCH, TACTILE (AUTO CAL) (PANEL BOARD)	
S927	1-554-303-21	SWITCH, TACTILE (COUNTER RESET) (PANEL BOARD) (WR565)	
S927	1-554-303-21	SWITCH, TACTILE (MEMORY) (PANEL BOARD) (WA7ES, WR665S)	
		< TEST PIN >	
* TP801	1-560-060-00	PIN, CONNECTOR 2P < FLUORESCENT INDICATOR TUBE >	
VFD901	1-517-263-11	INDICATOR TUBE, FLUORESCENT (PANEL BOARD)	
		< CRYSTAL >	
X801	1-579-175-11	VIBRATOR, CERAMIC (10MHz)	

		MISCELLANEOUS *****	
△5	1-569-007-11	ADAPTER, CONVERSION 2P (E)	
△6	1-551-188-XX	CORD, POWER (E)	
△6	1-558-945-21	CORD, POWER (POLAR. SPT-1) (US, CND)	
△6	1-575-651-21	CORD, POWER (AEP, G, CH)	
△6	1-696-586-11	CORD, POWER (UK)	
△6	1-696-845-11	CORD, POWER (AUS)	

Ref. No.	Part No.	Description	Remark
16	1-765-216-11	WIRE (FLAT TYPE) (11 CORE)	
67	1-765-214-11	WIRE (FLAT TYPE) (7 CORE)	
71	1-765-217-11	WIRE (FLAT TYPE) (37 CORE)	
72	1-765-215-11	WIRE (FLAT TYPE) (7 CORE)	
74	1-765-213-11	WIRE (FLAT TYPE) (7 CORE)	
121	1-638-983-11	PC BOARD, MOTOR FLEXIBLE	
HP101	A-2003-757-A	BASE ASSY, HEAD (PLAY BACK) (DECK A)	
HRPE101A	2003-930-A	BASE ASSY, HEAD (RECORD, PLAYBACK, ERASE) (DECK B)	
△S701	1-692-155-11	SELECTOR, POWER VOLTAGE (E)	
△T701	1-427-782-11	TRANSFORMER, POWER (US, CND)	
△T701	1-427-783-11	TRANSFORMER, POWER (AEP, UK, G, AUS, CH)	
△T701	1-427-784-11	TRANSFORMER, POWER (E)	

		ACCESSORIES & PACKING MATERIALS *****	
	1-551-734-11	CORD, CONNECTION	
	3-755-288-11	MANUAL, INSTRUCTION (RM) (ENGLISH, FRENCH) (WR665S:CND)	
	3-798-411-11	MANUAL, INSTRUCTION (ENGLISH, FRENCH, SPANISH, PORTUGUESE) (WR565:AEP, E/WR665S:AEP, E)	
	3-798-411-21	MANUAL, INSTRUCTION (ENGLISH) (WR565:US, CND, UK, AUS/ WR665S:US, CND, UK, AUS)	
	3-798-411-31	MANUAL, INSTRUCTION (FRENCH) (WR565:CND/WR665S:CND/)	
	3-798-411-41	MANUAL, INSTRUCTION (GERMAN, DUTCH, SWEDISH, ITALIAN) (WR565:AEP/WR665S:AEP)	
	3-798-411-51	MANUAL, INSTRUCTION (GERMAN) (WR565:G/WR665S:G)	
	3-798-411-61	MANUAL, INSTRUCTION (CHINESE) (WR565:CH/WR665S:CH)	
	3-798-792-21	MANUAL, INSTRUCTION (ENGLISH) (WA7ES)	
*	3-907-887-01	CUSHION	
*	3-921-800-01	INDIVIDUAL CARTON (WR665S:US, CND, E, AUS)	
*	3-921-800-11	INDIVIDUAL CARTON (WR665S:AEP, UK, G, CH)	
*	3-921-800-21	INDIVIDUAL CARTON (WR565:US, CND, E, AUS)	
*	3-921-800-31	INDIVIDUAL CARTON (WR565:AEP, UK, G, CH)	
*	3-923-965-41	INDIVIDUAL CARTON (WA7ES)	

<p>The components identified by mark △ or dotted line with mark △ are critical for safety. Replace only with part number specified.</p>	<p>Les composants identifiés par une marque △ sont critiques pour la sécurité. Ne les remplacer que par une pièce portant le numéro spécifié.</p>
---	---

<u>Ref. No.</u>	<u>Part No.</u>	<u>Description</u>	<u>Remark</u>
		***** HARDWARE LIST *****	
#1	7-685-871-01	SCREW +BVTT 3×6 (S)	
#2	7-685-646-79	SCREW +BVTP 3×8 TYPE2 IT-3	
#3	7-682-547-09	SCREW +BVTT 3×6 (S)	
#4	7-682-548-04	SCREW +BVTT 3×8 (S)	
#5	7-685-134-19	SCREW (+ PIPWH) (2.6×8)	
#6	7-621-773-95	SCREW +BVTT 2.6×6 (S)	
#7	7-627-556-08	SCREW +P 2.6×2.8	
#8	7-621-775-00	SCREW +B 2.6×3	