

TTS-4000 PSE-4000

General Export and EP Model



[PSE-4000]



[TTS-4000]

SPECIFICATIONS

GENERAL

- Speeds:** 33 $\frac{1}{3}$, 45 rpm, 3% adjustable
- Turntable drive:** Direct-drive system
- Wow and flutter:** { Less than 0.03% (RMS)
(weighted) { Less than 0.07% (DIN 45507)
- Signal-to-noise ratio:** { Greater than 60 dB (JIS)
(weighted) { Greater than 67 dB (DIN 45544)
- Motor:** AC servo-controlled motor
- Power consumption:** Approx. 17 watts
- Power requirement:** 110, 127, 220 and 240 volts ac,
50/60 Hz (EP Model)
100, 120, 220 and 240 volts ac,
50/60 Hz (General Export Model)
- Dimensions:** TTS-4000
Turntable assembly:
343 mm (dia) x 145.6 mm (height)
13 $\frac{1}{2}$ " (dia) x 5 $\frac{3}{4}$ " (height)

PSE-4000

563 mm (width) x 212 mm (height) x
420 mm (depth)
22 $\frac{1}{2}$ " (width) x 8 $\frac{1}{2}$ " (height) x
16 $\frac{1}{2}$ " (depth)

Control box:

116 mm (width) x 87 mm (height) x
66 mm (depth)
4 $\frac{9}{16}$ " (width) x 3 $\frac{7}{16}$ " (height) x
2 $\frac{5}{8}$ " (depth)

Weight:

TTS-4000
Approx. 9.8 kg (21 lb 10 oz)

PSE-4000

Approx. 18 kg (39 lb 11 oz)
(with control box)

Control box:

Approx. 0.4 kg (9.6 oz)

Shipping weight:

TTS-4000
12.5 kg (27 lb 7 oz)

PSE-4000

23 kg (50 lb 12 oz)

SONY®

SERVICE MANUAL

TABLE OF CONTENTS

<u>Title</u>	<u>Page</u>
Servicing Notes	1
SECTION 1. TECHNICAL DESCRIPTION	
1-1. Technical Specifications	2
1-2. Principle of AC Servo System	2
1-3. Block Diagram	5
SECTION 2. DISASSEMBLY AND REPLACEMENT	
2-1. Top Cover Removal (PSE-4000 only)	6
2-2. Turntable Platter Removal	6
2-3. Turntable Assembly Removal	6
2-4. Chassis Removal	6
SECTION 3. ADJUSTMENTS	8
SECTION 4. REPACKING	9
SECTION 5. DIAGRAMS	
4-1. Mounting Diagram	11
4-2. Schematic Diagram	13
SECTION 6. EXPLODED VIEW	15
SECTION 7. ELECTRICAL PARTS LIST	18

SERVICING NOTES

1. OPERATIONAL CHECK

Operational check should be performed by putting the platter in place. This causes difficulty of electrical check at operation. A pair of special

extension cord (1-534-731-11) is ready at the factory service department. By using the extension cord, operational check is performed as illustrated.

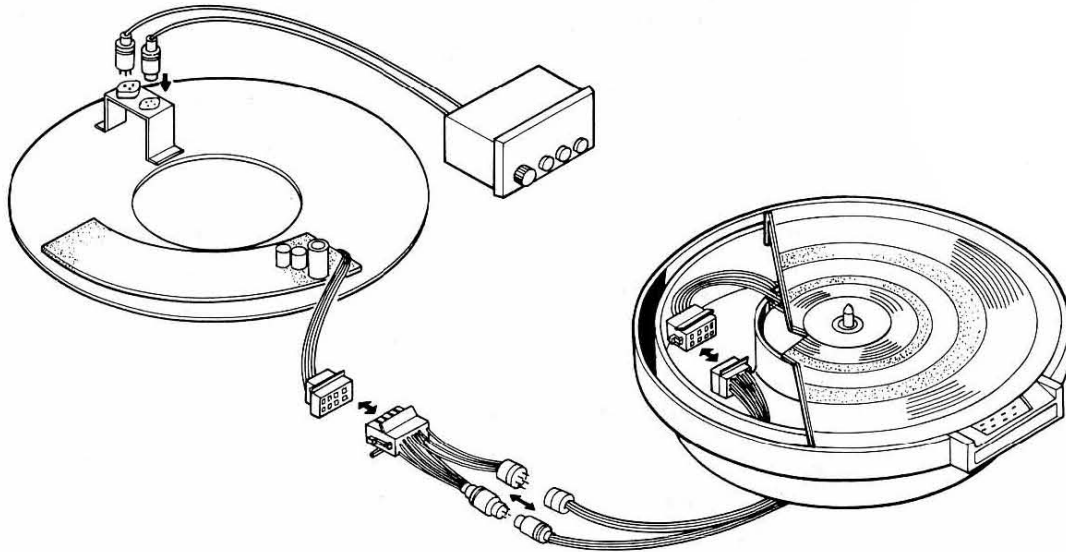

Fig. A Operational check connection

2. ADAPTATION TO THE LOCAL POWER LINE

This turntable can be adapted to operate at several different power-line voltages. The line-voltages selection can be performed as follows:

1. Remove the turntable platter as described in Procedure 2-2 on page 6.
2. Remove the four screws shown in Fig. B. This frees the cover plate.
3. Pull off the voltage changeover knob, then reset it as required.

3. LUBRICATION

Lubricate the turntable shaft once a year. Use the SONY OL-2K oil supplied. Remove the top of the turntable shaft by turning it counterclockwise, and then apply two or three drops of oil to the opening of the shaft as shown in Fig. C. Do not apply too much oil.

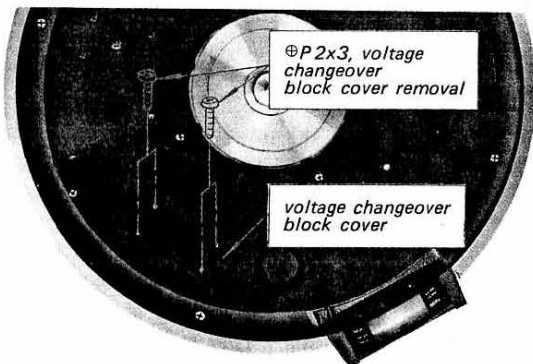

Fig. B. Voltage changeover block cover removal

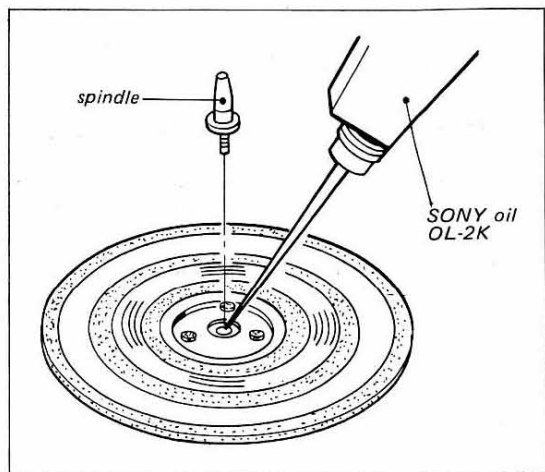

Fig. C. Lubrication

**SECTION 1
TECHNICAL DESCRIPTION**

1-1. SPECIFICATIONS

General

Speeds:	33 1/3, 45 rpm, 3% adjustable
Turntable drive:	Direct-drive system
Wow and flutter: (weighted)	{ Less than 0.03% (RMS) Less than 0.07% (DIN 45507)
Signal-to-noise ratio: (weighted)	{ Greater than 60 dB (JIS) Greater than 67 dB (DIN 45544)
Motor:	AC servo-controlled motor
Power consumption:	Approx. 17 watts
Power requirement:	110, 127, 220 and 240 volts ac, 50/60 Hz (EP Model) 100, 120, 220 and 240 volts ac, 50/60 Hz (General Export Model)
Dimensions:	TTS-4000 Turntable assembly: 343 mm (dia) x 145.6 mm (height) 13 1/2" (dia) x 5 3/4" (height) PSE-4000 563mm (width) x 212mm (height) x 420mm (depth) 22 1/2" (width) x 8 1/2" (height) x 16 1/2" (depth) Control box: 116mm (width) x 87mm (height) x 66mm (depth) 4 9/16" (width) x 3 7/16" (height) x 2 5/8" (depth)
Weight:	TTS-4000 Approx. 9.8 kg (21 lb 10 oz) PSE-4000 Approx. 18 kg (39 lb 11 oz) (with control box) Control box: Approx. 0.4 kg (9.6 oz)

1-2. PRINCIPLE OF AC SERVO SYSTEM

Fig. 1-1 shows a simplified diagram of the ac servo system employed in this set. Since the ac motor speed is proportional to the applied ac voltage, it is controlled by varying the applied voltage (Em) to the motor. This is effectively performed by means of series resistor Rv.

In practice, series resistor Rv is replaced by the diode-bridge circuit and collector-emitter impedance of a power transistor as illustrated in Fig. 1-2. Note that the diode-bridge determines only the direction of the ac current which flows in the power transistor.

Motor speed is converted into ac signal by means of a direct-coupled frequency generator.

The servo amplifier compares this signal against a very stable dc reference voltage, and then controls the collector-emitter impedance of power transistor. Any error in motor speed results in a correction voltage supplied to the motor.

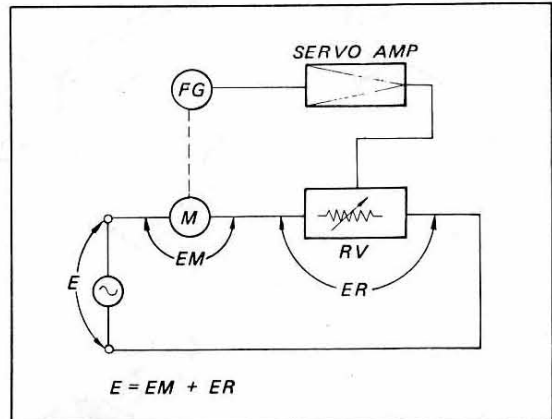

Fig. 1-1. Principle of ac servo system

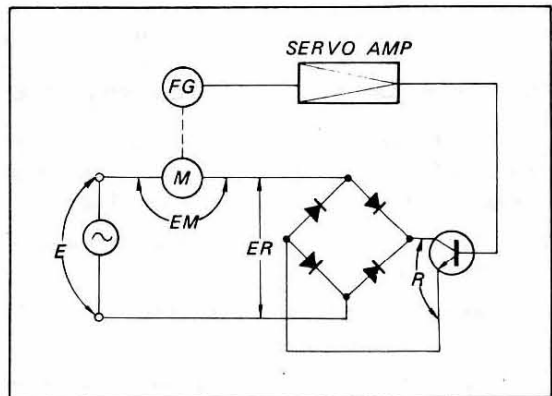

Fig. 1-2. Practical ac servo system

Stage/Control

Function

Start Operation

When the power switch is turned on, Q06 in the base circuit of Q07 is cut-off. As a result, C8 in the collector circuit is charged through R10, R11, R12, R13 and R14 when the 33 rpm button is depressed. Note that R11 and R12 are shorted during 45 rpm operation. Q07 is forced into conduction when C8 is charged up to some specified voltage. As a result the following conditions exist:

<i>Stage/Control</i>	<i>Function</i>
	<u>Q09</u> <u>Q010</u> <u>Q011</u> <u>Q3</u> <u>Q4</u> <u>Q5</u> <u>Q9</u>
	OFF OFF ON ON ON ON ON
	and a large enough ac voltage is applied to the motor so the motor starts to revolve rapidly.

Correct Speed Condition

Frequency generator	When the motor starts to revolve, the frequency generator (F.G.) generates ac voltage whose frequency is proportional to the motor speed. As the frequency generator is directly coupled to the shaft of the drive motor, it converts motor speed into frequency.
Differential amplifier Q1, Q2	Q1 and Q2 form a differential amplifier which amplifies the input FG signal to the level required for the following limiter circuit. Note that the output is extracted from collector circuit of Q1 and Q2, and then fed to the flip-flop stage through diode limiter D1 and D2.
Diode limiter D1, D2	Removes all amplitude variations from the signal. Each diode conducts when the signal across it exceeds the barrier potential (0.6 V) in a forward biased condition. Thus, the output signal is limited to about 1.2 V peak-to-peak.
Flip-flop circuit Q01, Q02	Q01 and Q02 form a flip-flop circuit which generates square output in accordance with the input trigger signal (limiter's output). The flip-flop output is extracted at collector circuit of Q02 and then fed to the buffer amplifier stages.
Buffer/phase inverter Q03, Q04, Q05	Q03, Q04 and Q05 form a buffer amplifier stage. Note that Q03 and Q05 are emitter followers but, Q04 acts as a phase inverter.
Differentiation circuit C7, R012	Square wave output at the emitter circuit of Q05 is converted into spike pulses through the differentiator circuit (formed by C7 and R012) to trigger the following saw-tooth wave generator (Q06).

<i>Stage/Control</i>	<i>Function</i>
Saw-tooth wave generator Q06, C8, R11, R12, R13, R14	Q06 and RC components (C8, R11, R12, R13, R14) in the collector circuit form a saw-tooth wave generator. Note that the frequency of the saw-tooth wave is determined by the RC time constants in the collector circuit.
Voltage comparator Q07, Q08	The saw-tooth is fed to the voltage comparator formed by Q07 and Q08. Q08 is forward biased through the FINE control (R36 paralleled by R34), R35 and R37. The current flow in Q08 is controlled by the FINE control (R36), which varies its base-emitter voltage. Q07 conducts only when the base voltage becomes higher than the emitter voltage which is determined by the current flow in Q08. Note that the emitter voltage of Q08 serves as a reference voltage. Referring to Fig. 1-3, the comparator operates as follows: At time T1 a saw-tooth signal is applied to the base of Q07. At time T2 the voltage at the base of Q07 is sufficient to turn on Q07 generating a negative pulse. Note that the pulse width is determined by saw-tooth signal waveform.
Buffer/phase inverter Q09, Q010, Q011	Q09 and Q011 are emitter followers but Q010 acts as a phase inverter providing a positive pulsating signal to the following stages.
Low pass filter /buffer amplifier	Buffer amplifier Q3 and an RC network consisting of R16, C11, C12, C13, R18, R19 and C14 comprise a low-pass filter having a sharp rolloff characteristic. Notice that this stage acts as an integrator, converting the input positive pulses into a dc voltage proportional to the input pulse width.
Dc amplifiers Q4, Q5, Q9	Dc output from the low-pass filter is applied to the base of Q4. As Q4, Q5 and Q9 are directly coupled, a change in input dc voltage alters the conduction of Q9, controlling the voltage applied to the motor.

Stage/Control

Function

Servo Operation

When, by any cause, the motor speed becomes slightly faster or slower than the specified value, the servo system works as follows:

Referring to Fig. 1-3, assume that the motor speed becomes faster. The FG output signal frequency becomes higher, resulting in a shorter interval between pulses for triggering the saw-tooth wave generator. The shorter interval between trigger pulses causes lower saw-tooth wave height, which in turn yields a shorter "ON" period for comparator Q07. Therefore, the output pulse width at the emitter circuit of Q011 becomes shorter, reducing the positive bias upon Q4.

As a result, the collector-emitter impedance of Q9 increases, reducing the motor speed.

Conversely, if the motor speed becomes slower, the collector-emitter impedance of Q9 decreases, increasing the motor speed.

Electromagnetic brake circuit

This operates only when the motor speed becomes excessively faster than the specified value which occurs at

Stage/Control

Function

the instant of the motor speed from 45 rpm to 33 $\frac{1}{3}$ rpm.

Q6, Q7, Q8

Q6, Q7, Q8 act as electronic switches. Normally, Q6 is ON, Q7 is OFF and Q8 is OFF which has no effect upon motor operation. See Fig. 1-4.

When the motor speed becomes ex-

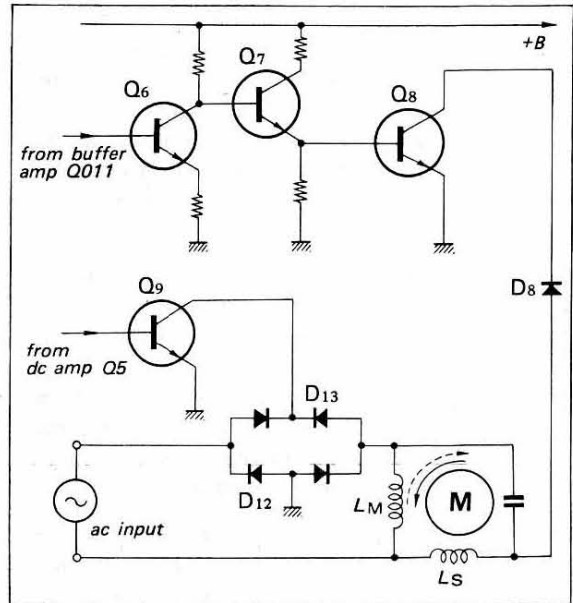

Fig. 1-4. Electromagnetic brake circuit

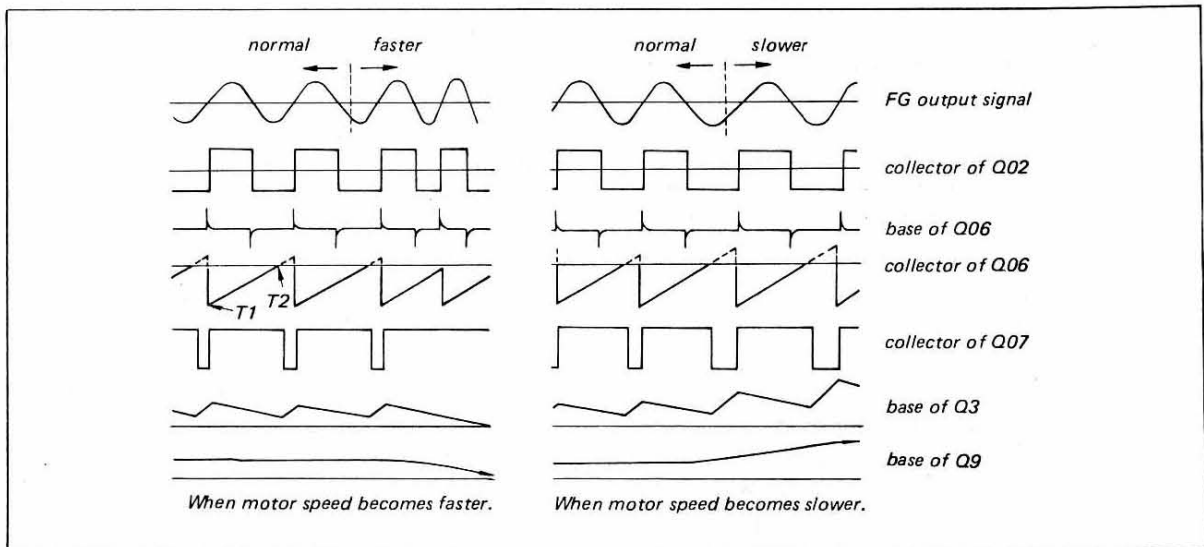

Fig. 1-3. Waveforms on servo control circuit

Stage/Control

Function

cessively faster, servo amplifier will not supply any control pulse to the dc power regulator Q9 or Q6. As a result, Q6 is OFF, Q7 is ON and Q8 is ON. The current now flows through Ls, D8, Q8 at each half cycle of the input ac power since Q9 is OFF. See Fig. 1-4. This generates counter electromotive force upon the motor, decreasing speed effectively.

Power supply A positive 12 volts for the system is provided by the full-wave rectifier consisting of D10 and D11, filter capacitors C15, C22 and zener diode D9.

Stage/Control

Function

Speed selector switch S2, S3

Speed changeover operation is performed by changing the saw-tooth wave frequency as previously described. Since the saw-tooth wave frequency is determined by the RC time constant in the collector circuit of Q06, a speed selector switch is connected in parallel with R11 and R12. A smaller time constant results in faster motor speed and vice versa. So S2 and S3 are open when the speed selector switch is set to 33 1/3 rpm.

1-3. BLOCK DIAGRAM

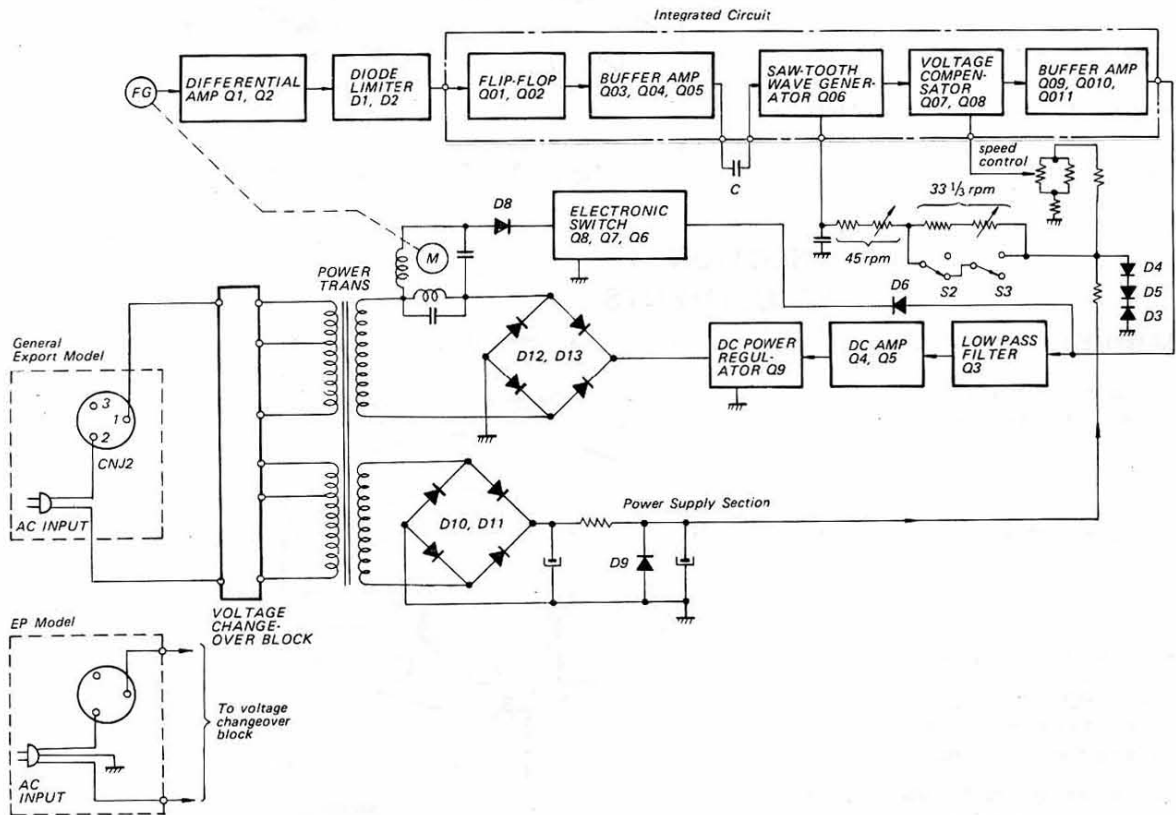

SECTION 2 DISASSEMBLY AND REPLACEMENT

WARNING

Unplug the ac power cord before starting any disassembly or replacement procedures.

2-1. TOP COVER REMOVAL (PSE-4000 ONLY)

1. Open the top cover, and then push the lower part of top cover to the right as far as it will go.
2. Carefully push the hinge backward. This frees the top cover as shown in Fig. 2-1.
3. To reassemble the top cover, reverse the foregoing procedures.

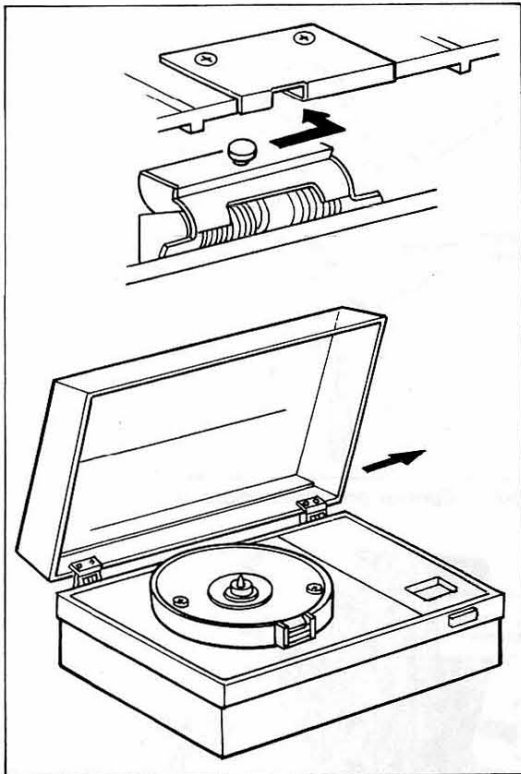

Fig. 2-1. Top cover removal

2-2. TURNTABLE PLATTER REMOVAL

1. Remove the rubber mat from the turntable.
2. Insert your fingers into the two turntable platter holes with both thumbs placed on the center spindle.
3. Remove the turntable by pulling it straight up as shown in Fig. 2-2.

2-3. TURNTABLE ASSEMBLY REMOVAL

1. Remove the turntable platter as described in Procedure 2-2.
2. Disconnect the two control box cables at the bottom.
3. Remove the four screws securing the turntable assembly to the wooden case shown in Fig. 2-3. This frees the turntable assembly.

2-4. CHASSIS REMOVAL

1. Remove the turntable assembly as described in Procedure 2-3.
2. Remove the ten screws securing the turntable base to the chassis shown in Fig. 2-4. This frees the chassis as shown in Fig. 2-5.

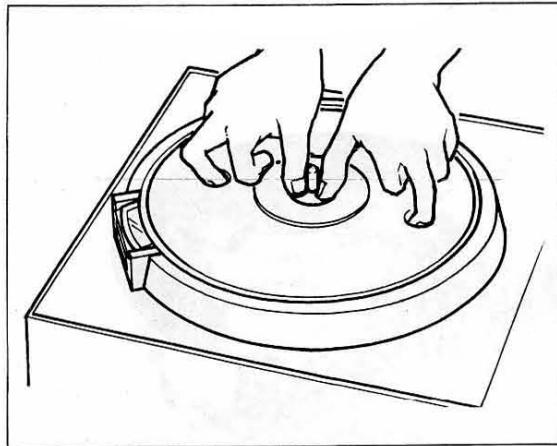

Fig. 2-2. Turntable platter removal

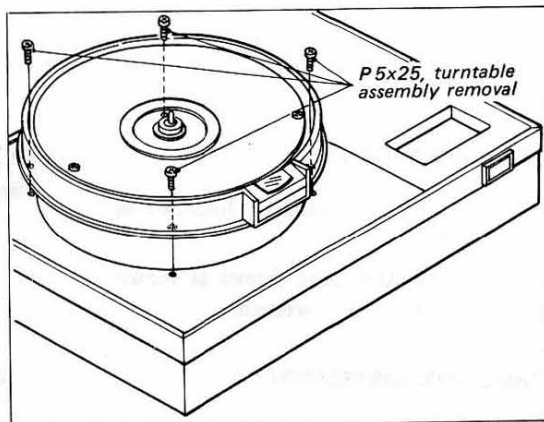

Fig. 2-3. Turntable assembly removal

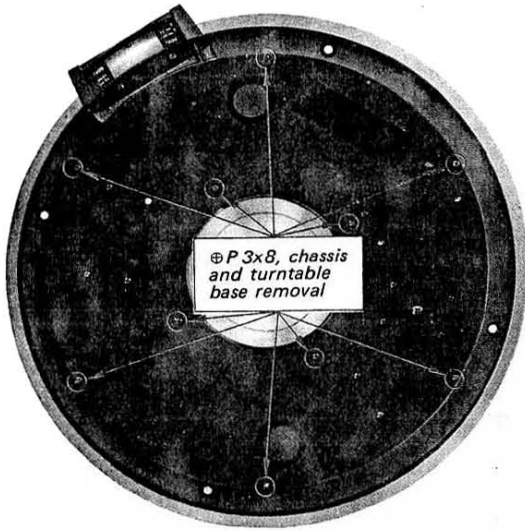

Fig. 2-4. Chassis and turntable base removal (1)

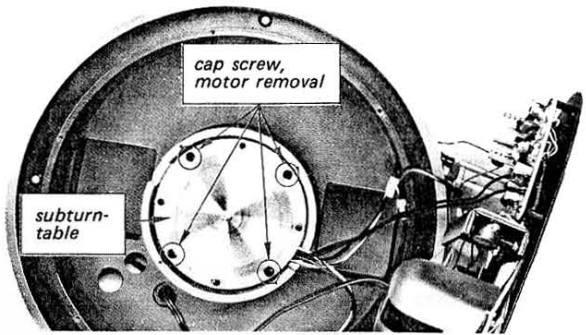

Fig. 2-6. Motor replacement

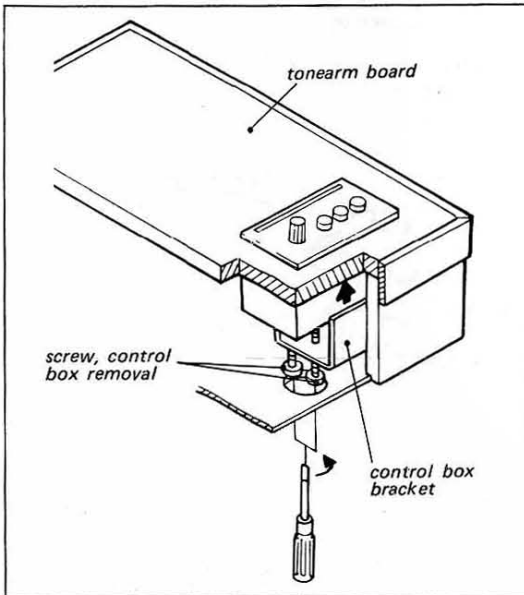

Fig. 2-7. Control box disassembly (1)

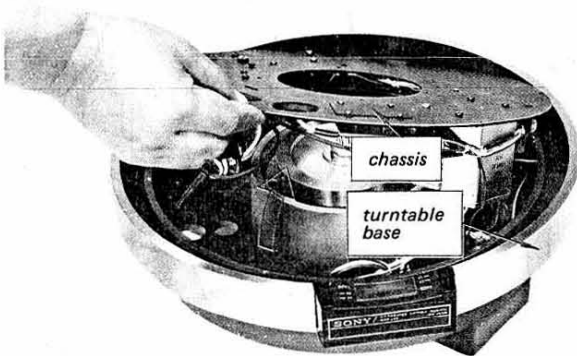

Fig. 2-5. Chassis and turntable base removal (2)

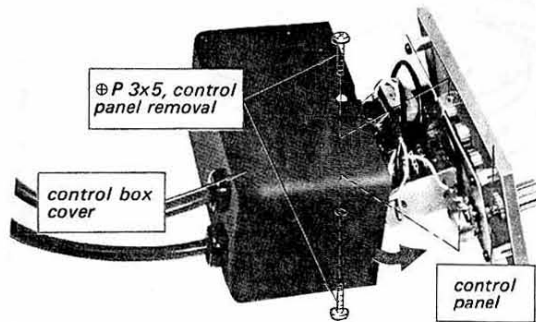

Fig. 2-8. Control box disassembly (2)

2-5. MOTOR REPLACEMENT

1. Remove the turntable chassis as described in Procedure 2-4.
2. Remove the four Allen-head screws as shown in Fig. 2-6, with hexagonal wrench.

2-6. CONTROL BOX DISASSEMBLY

1. Remove the two screws from the bottom of the control box as shown in Fig. 2-7.
2. Remove the two screws shown in Fig. 2-8. This frees the control switch mechanism together with control panel as shown in Fig. 2-8.

2-7. CONTROL KNOB AND PUSHBUTTON REMOVAL

1. Remove the control switch mechanism as described in Procedure 2-6.
2. Apply a cement solvent to the knob or pushbutton from the back, then pull it off.

2-8. FUSE REPLACEMENT

1. Remove the four screws shown in Fig. 2-9. This frees the cover plate.
2. Pry out the defective fuse then install a new one.

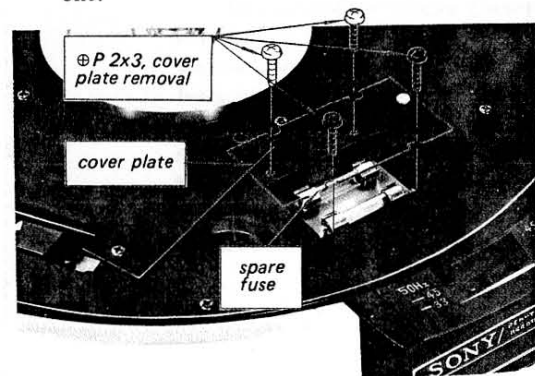

Fig. 2-9. Fuse replacement

2-9. STROBE LAMP REPLACEMENT

1. Remove the chassis as described in Procedure 2-4, and then unsolder the two red lead wires from the printed circuit board and MP capacitor.

2. Remove the two screws securing the lamp shade to the turntable base shown in Fig. 2-10. This frees lamp shade.
3. Remove the lamp holder and light shield plate and then apply a drop of cement solvent to the lamp.
4. Install a new lamp. Be sure that the glowing side (front) of the lamp is correctly positioned as shown in Fig. 2-10.

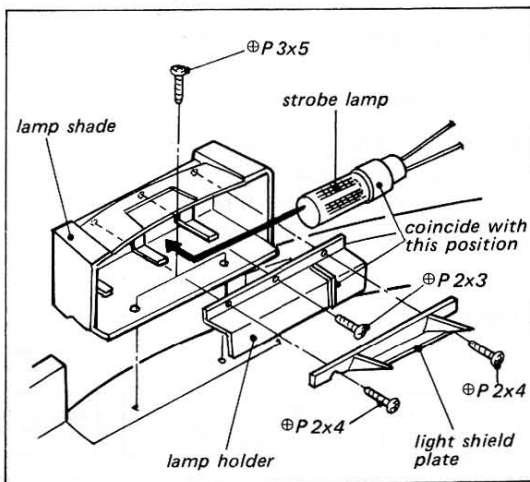

Fig. 2-10. Strobe lamp replacement

**SECTION 3
ADJUSTMENTS**

3-1. SPEED ADJUSTMENT

Note: Be sure that the turntable platter is in place when performing speed adjustment.

Preparation

1. Remove the chassis as described in Procedure 2-4.

Procedure

1. Set the speed control to mid position.
2. Set the 33 1/3/45 control to the 45 position, and then turn adjustable resistor R13 (See Fig. 3-1) to obtain the correct indication.
If this does not change the situation, adjust R14 on the printed circuit board.
3. After completing the 45 rpm adjustment, proceed to the 33 1/3 rpm adjustment as previously described, except turning adjustable resistor R11 (See Fig. 3-1).
If this does not change the situation, adjust R12 on the printed circuit board.

4. If above mentioned procedures do not change the situation, perform operational check and repair the defective circuit.

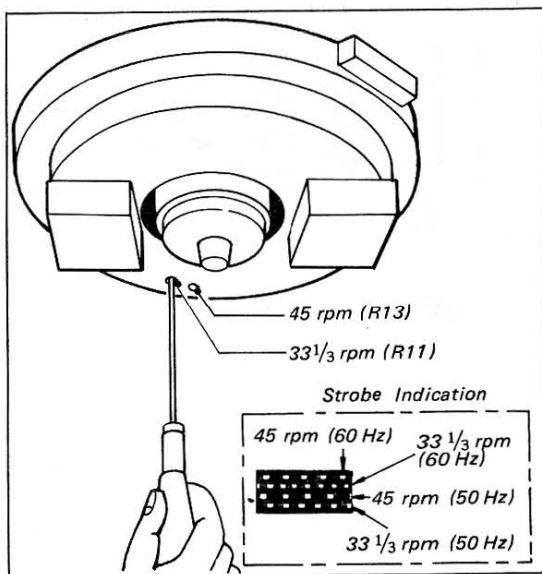

Fig. 3-1. Speed adjustment

SECTION 4 REPACKING

The TTS-4000/PSE-4000 original shipping carton and packing materials are the ideal containers for shipping the unit. However to secure the maximum protection, the TTS-4000/PSE-4000 must be repacked

in these materials precisely as before. The proper repacking procedures are shown in Figures 4-1 and 4-2.

[TTS-4000]

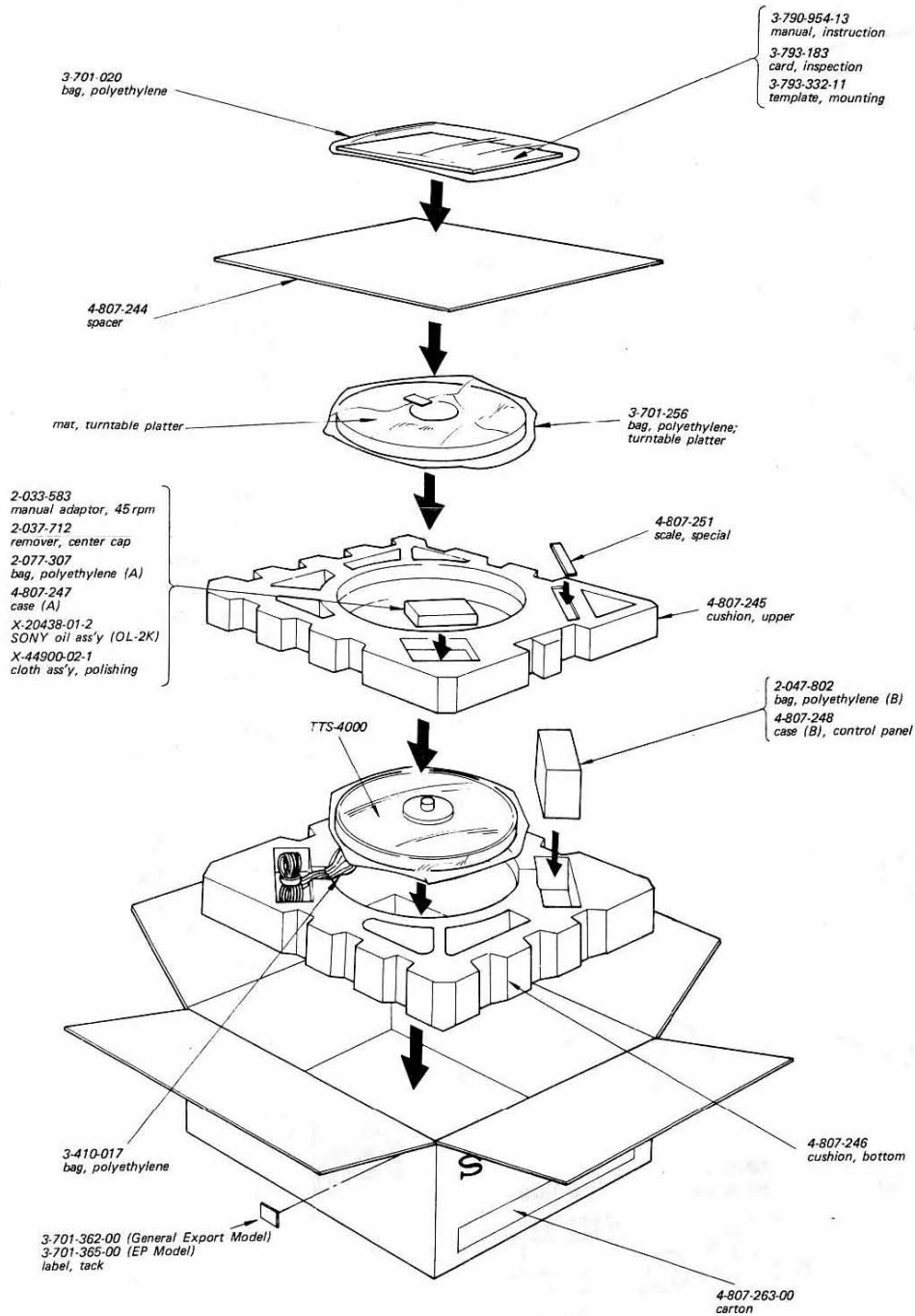

Fig. 4-1. Repacking

[PSE-4000]

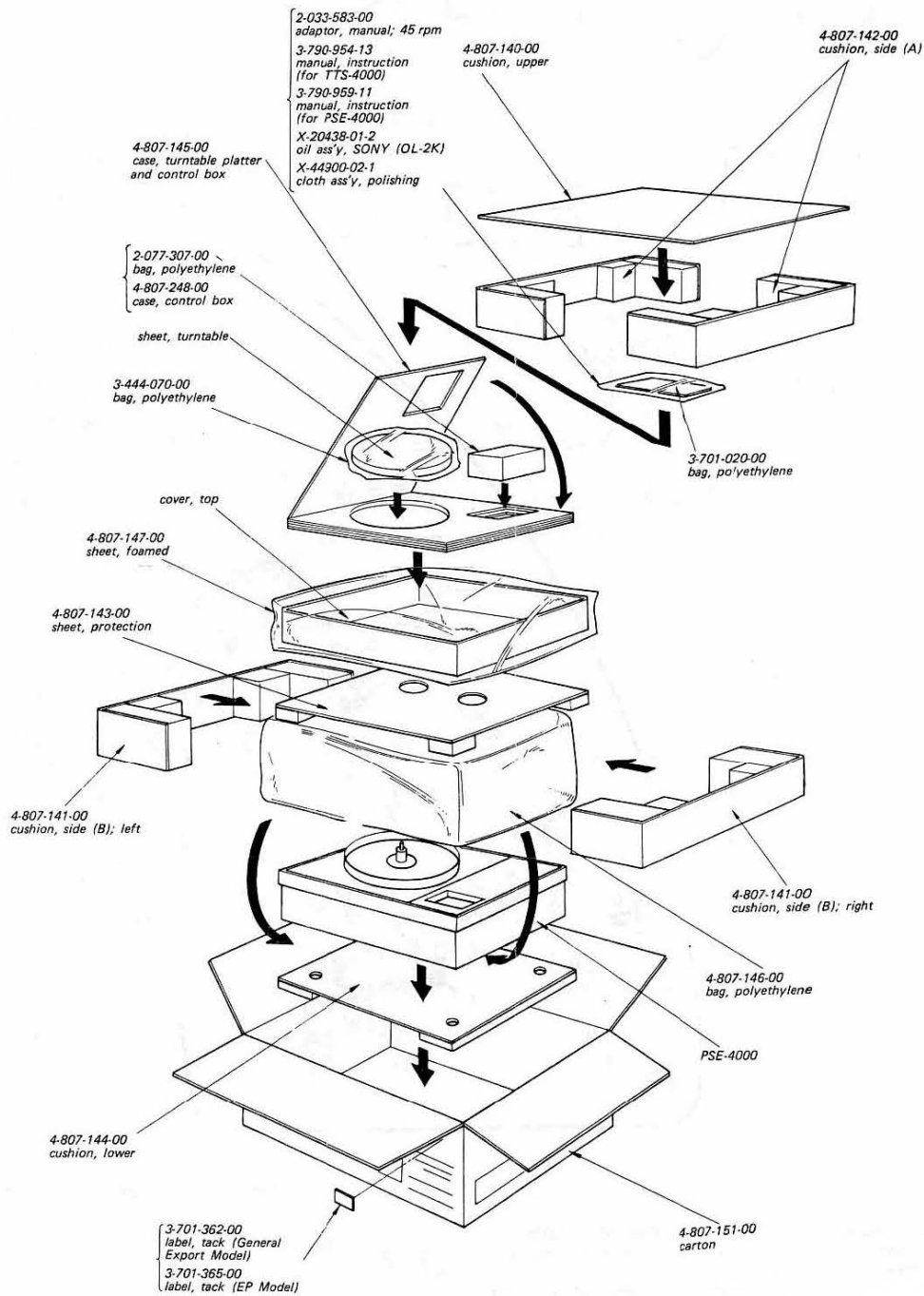
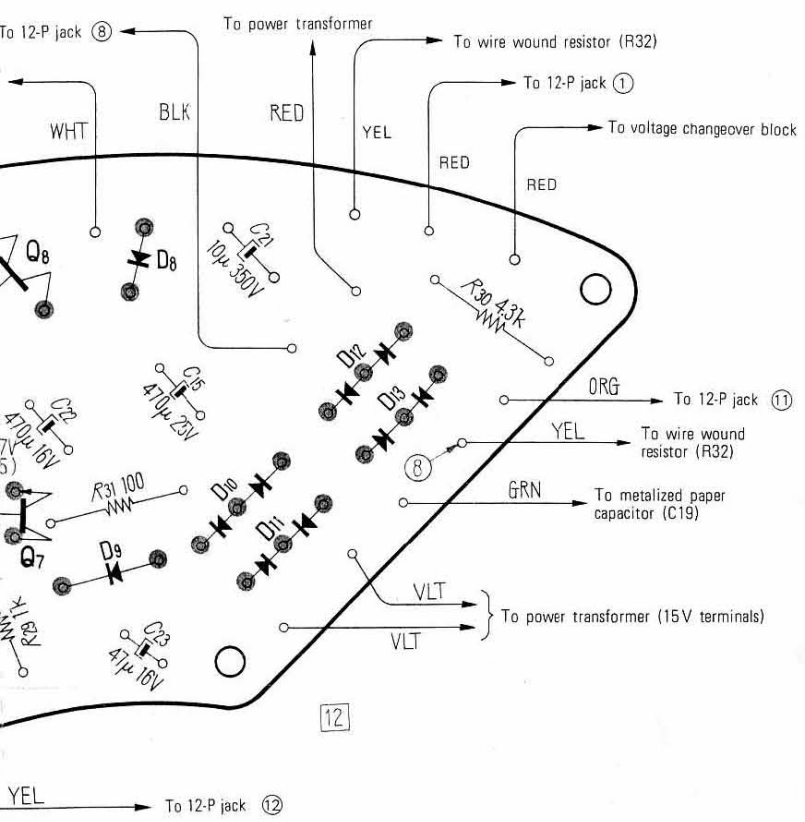
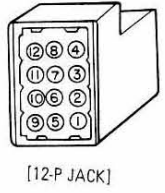
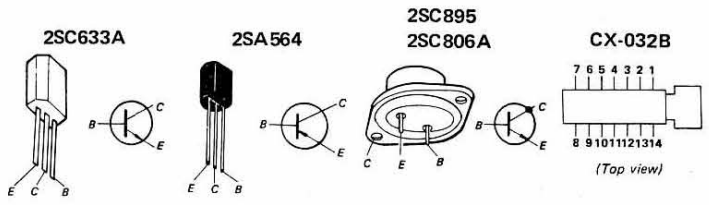
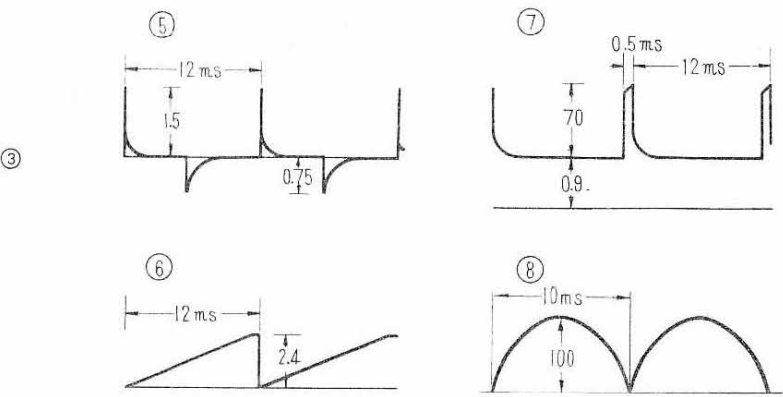

Fig. 4-2. Repacking



D1	10D-05
D2	10D-05
D3	1T-243M
D4	10D-05
D5	10D-05
D6	10D-05
D7	10D-05
D8	10D-4
D9	ZBI-12
D10	CDR-2
D11	CD-2
D12	CDR-4
D13	CD-4

Q1	2SC633A
Q2	2SC633A
Q3	2SC633A
Q4	2SC633A
Q5	2SA564
Q6	2SC633A
Q7	2SC633A
Q8	2SC895
Q9	2SC806A
X1	CX-032B





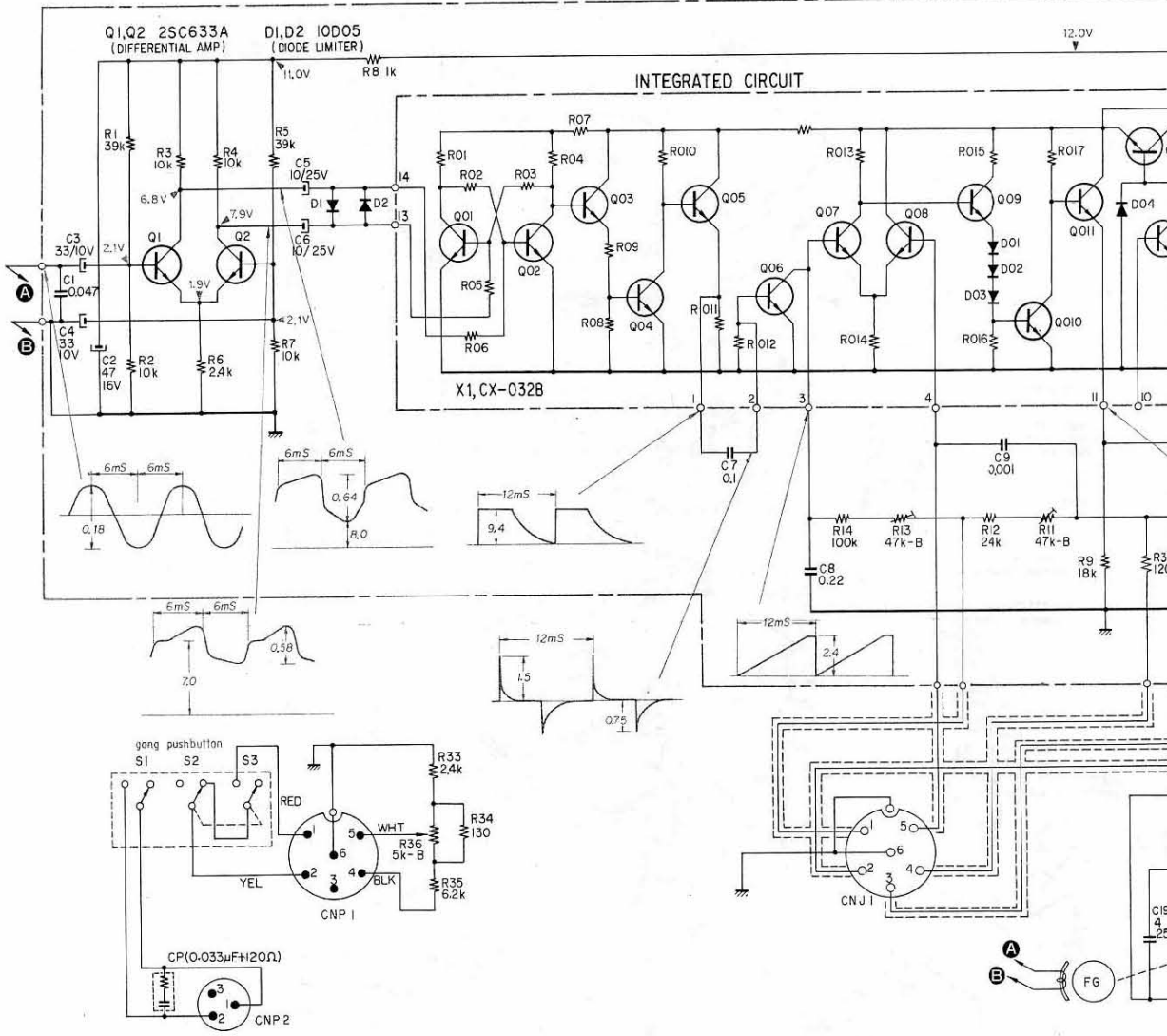







5-2. SCHEMATIC DIAGRAM



SECTION 6
EXPLODED VIEWS

(1) The following chart will help you to decipher the hardware codes given in the exploded view.

– Hardware Nomenclature –

P – Pan Head Screw 	SC – Set Screw 
PS – Pan Head Screw with Spring Washer 	E – Retaining Ring (E Washer) 
K – Flat Countersunk Head Screw 	W – Washer
B – Binding Head Screw 	SW – Spring Washer
RK – Oval Countersunk Head Screw 	LW – Lock Washer
T – Truss Head Screw 	N – Nut
R – Round Head Screw 	
F – Flat Fillister Head Screw 	

– Example –

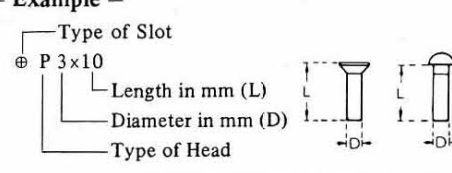

(2) To simplify the exploded view, the part numbers of normal screws, nuts, washers, and retaining rings are not expressed but summarized in the table below.

<u>Part No.</u>	<u>Description</u>	<u>Part No.</u>	<u>Description</u>
7-681-363-04	screw, ⊕ RK 4 × 12	7-685-102-25	screw, self-tapping; ⊕ P 2 × 4
7-682-123-05	screw, ⊕ P 2 × 3	7-621-761-64	screw, wood; ⊕ K 5.1 × 25
7-682-146-01	screw, ⊕ P 3 × 5	7-621-843-48	screw, wood; ⊕ R 3.1 × 16
7-682-147-05	screw, ⊕ P 3 × 6	7-623-110-05	washer, 4 mm dia.
7-682-149-03	screw, ⊕ P 3 × 10	7-623-108-15	washer, flat; 3 mm dia.
7-682-151-01	screw, ⊕ P 3 × 14	7-623-112-04	washer, flat; 5 mm dia.
7-682-152-03	screw, ⊕ P 3 × 16	7-623-208-12	washer, spring; 3 mm dia.
7-682-165-01	screw, ⊕ P 4 × 16	7-623-408-02	washer, lock (ext. tooth); 3 mm dia.
7-682-173-05	screw, ⊕ P 5 × 6	7-623-508-01	lug, 3 mm dia.
7-682-180-05	screw, ⊕ P 5 × 25	7-623-058-31	lug, dual; 3 mm dia.
7-682-281-02	screw, ⊕ K 5 × 30	7-684-013-00	nut, 3 mm dia.
7-682-448-04	screw, ⊕ T 3 × 8	7-684-014-00	nut, 4 mm dia.
7-682-356-06	screw, ⊕ RK 3 × 35	7-684-015-02	nut, 5 mm dia.
7-682-361-14	screw, ⊕ RK 4 × 8	7-683-420-01	bolt, hexagon head; 4 mm dia. × 10 mm
7-682-467-03	screw, ⊕ T 4 × 25		

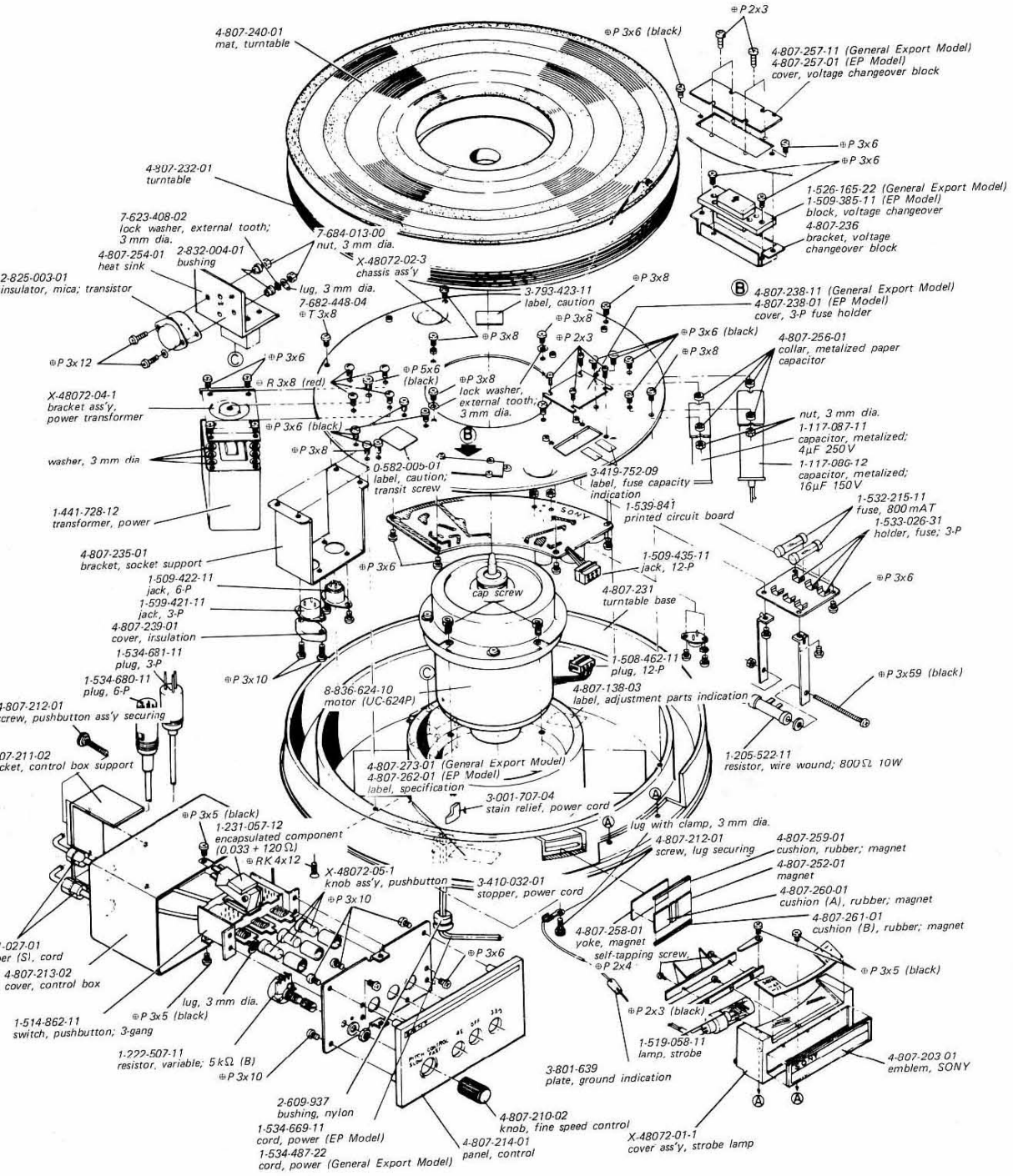

— [PSE-4000] —

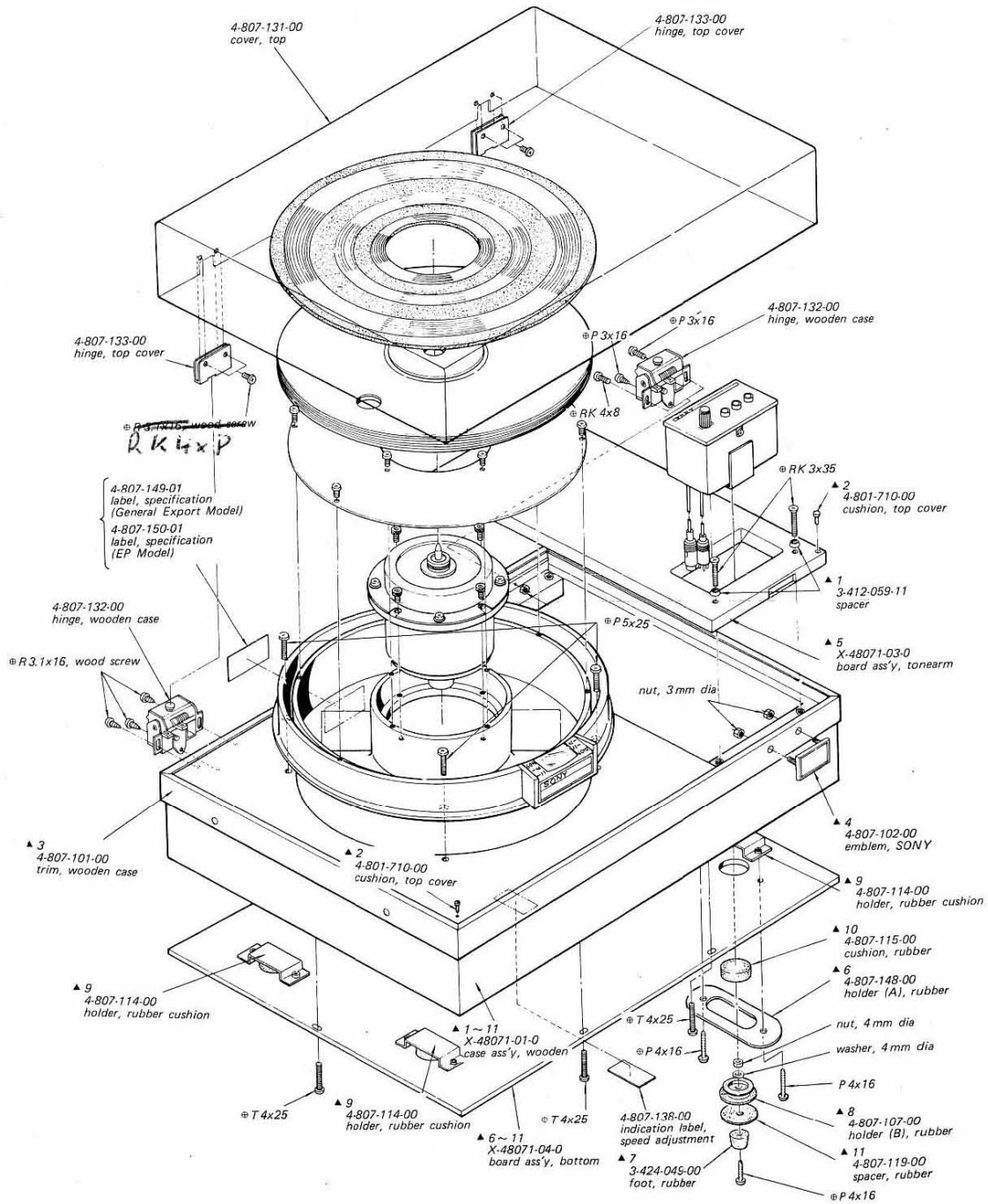

Note: ▲6 ~ 11 Bottom board ass'y (X-48071-04-0) includes all the parts marked ▲.
 ▲1 ~ 11 Wooden case ass'y (X-48071-01-0) includes all the parts marked ▲.

<u>Ref. No.</u>	<u>Part No.</u>	<u>Description</u>	
R30	1-244-888-11	4.3 k	±5% ½W
R31	1-244-849-11	100	±5% ½W
R32	1-205-522-11	800	±5% 10W wire wound
R33	1-244-682-11	2.4 k	
R34	1-244-652-11	130	
R35	1-244-692-11	6.2 k	
R36	1-222-507-11	5 k (B),	variable
R37	1-244-651-11	120	

SWITCHES

S1 } S2 } S3 }	1-514-862-00	switch, pushbutton; 3-gang
----------------------	--------------	----------------------------

MISCELLANEOUS

CP	1-231-057-12	encapsulated component, 0.033µF + 120Ω
	1-508-462-00	plug, 12-P AMPLOK with lead wires

<u>Ref. No.</u>	<u>Part No.</u>	<u>Description</u>
CNJ2	1-509-421-00	jack, 3-P
CNJ1	1-509-422-00	jack, 6-P
	1-509-435-00	jack, 12-P AMPLOK with lead wires
NL	1-519-058-00	lamp, strobe
	1-526-165-22	voltage changeover block (General Export Model)
VS	1-509-385-00	voltage changeover block (EP Model)
	1-533-026-31	holder, fuse; 3-P
CNP1	1-534-680-00	plug, 6-P
CNP2	1-534-681-00	plug, 3-P
M	8-836-624-10	motor UC-624P
	1-534-669-00	cord, power (EP Model)
	1-534-487-22	cord, power (General Export Model)
F1, 2	1-532-215-00	fuse, 800 mA

SONY CORPORATION

© 1972