

TXD-R11

SERVICE MANUAL

Canadian Model
AEP Model



Dolby noise reduction manufactured under license from
Dolby Laboratories Licensing Corporation.
"DOLBY" and the double-D symbol  are trademarks of
Dolby Laboratories Licensing Corporation.

CD Section	Model Name Using Similar Mechanism	NEW
	CD Mechanism Name	CDM28-5BD13
	Base Unit Name	BU-5BD13
Tape Deck Section	Model Name Using Similar Mechanism	TC-WR741
	Tape Transport Mechanism Type	TCM-190RB52C

SPECIFICATIONS

Compact Disc Player Section

System

Type	Compact disc digital audio system
Laser	Semiconductor laser
Wavelength	780 – 790 nm
Frequency response	2 Hz – 20 kHz (± 0.5 dB)
Signal-to-noise ratio	More than 100 dB
Dynamic range	More than 95 dB
Harmonic distortion	Less than 0.007%
Channel separation	More than 95 dB

Cassette Deck Section

System

Recording system	4-track 2-channel stereo
Bias	AC bias
Head (x 1)	Erasing F & F Playback/Recording SD
Motor	Capstan motor × 1 (DC servo motor) Reel motor × 1 (DC motor)
Wow and flutter	±0.14% W. Peak (IEC) 0.08% W. RMS (NAB) ±0.19% W. Peak (DIN)

Fast-winding time (approx.)

90 sec. (with Sony C-60 cassette)

Frequency response (Dolby NR off)

Type I tape, Sony Type I (NORMAL):
30 – 15,000 Hz (± 3 dB)
Type II tape, Sony Type II (HIGH):
30 – 17,000 Hz (± 3 dB)
Type IV tape, Sony Type IV (METAL):
30 – 18,000 Hz (± 3 dB)

Signal-to-noise ratio

(at peak level, weighted, and with Dolby NR off)

Type I tape, Sony Type I (NORMAL):
53 dB
Type II tape, Sony Type II (HIGH):
57 dB
Type IV tape, Sony Type IV (METAL):
57 dB

S/N ratio improvement

Dolby NR on	Approximate values
B	5 dB at 1 kHz, 10 dB at 5 kHz
C	15 dB at 500 Hz, 20 dB at 1 kHz

— Continue to next page —

COMPACT DISC CASSETTE
SONY®

Harmonic distortion Type I tape, Sony Type I (NORMAL):
0.4% (160 nWb/m 315 Hz, 3rd H.D.)
Type IV tape, Sony Type IV (METAL):
1.8% (250 nWb/m 315 Hz, 3rd H.D.)

Inputs

	Jack type	Maximum input sensitivity
TAPE IN	Phono jacks	0.16 V (input impedance: 47 kilohms)

Outputs

	Jack type	Maximum output level	Load impedance
TAPE OUT (FIXED)	Phono jacks	0.5 V (at a load impedance of 47 kilohms)	Over 10 kilohms
CD OUT (FIXED)	Phono jacks	2 V (at a load impedance of 50 kilohms)	Over 10 kilohms
PHONES (VARIABLE)	Stereo phone jack	0 - 3 mW (at a load impedance of 32 ohms)	

General

Power requirements

Where purchased	Power requirements
Europe	220 V - 230 V AC, 50/60 Hz
Canada	120 V AC, 60 Hz

Power consumption 23 W

Dimensions 430 x 125 x 280 mm (w/h/d)
(17 x 4 7/8 x 11 1/8 inches)

Mass (approx.) 4.5 kg (9 lb. 15 oz.)

Supplied accessories Audio connecting cord (2 phono plugs - 2 phono plugs) (3)

Design and specifications are subject to change without notice.

SAFETY-RELATED COMPONENT WARNING!!

COMPONENTS IDENTIFIED BY MARK Δ OR DOTTED LINE WITH MARK Δ ON THE SCHEMATIC DIAGRAMS AND IN THE PARTS LIST ARE CRITICAL TO SAFE OPERATION. REPLACE THESE COMPONENTS WITH SONY PARTS WHOSE PART NUMBERS APPEAR AS SHOWN IN THIS MANUAL OR IN SUPPLEMENTS PUBLISHED BY SONY.

ATTENTION AU COMPOSANT AYANT RAPPORT À LA SÉCURITÉ!

LES COMPOSANTS IDENTIFIÉS PAR UNE MARQUE Δ SUR LES DIAGRAMMES SCHÉMATIQUES ET LA LISTE DES PIÈCES SONT CRITIQUES POUR LA SÉCURITÉ DE FONCTIONNEMENT. NE REMPLACER CES COMPOSANTS QUE PAR DES PIÈCES SONY DONT LES NUMÉROS SONT DONNÉS DANS CE MANUEL OU DANS LES SUPPLÉMENTS PUBLIÉS PAR SONY.

TABLE OF CONTENTS

<u>Section</u>	<u>Title</u>	<u>Page</u>
Specifications	1
Servicing Notes	3
1. GENERAL		
	Location of Controls	4
2. DISASSEMBLY	5
3. ADJUSTMENTS		
3-1.	Mechanical Adjustments	6
3-2.	Electrical Adjustments	6
4. DIAGRAMS		
4-1.	Printed Wiring Boards	
	- Panel and Mechanism Section -	12
4-2.	Schematic Diagram	
	- Panel and Mechanism Section -	15
4-3.	Schematic Diagram - Main Section -	20
4-4.	Printed Wiring Boards - Main Section -	25
4-5.	IC Pin Function Description	29
5. EXPLODED VIEWS	33
6. ELECTRICAL PARTS LIST	38

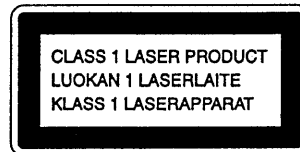

This appliance is classified as a CLASS 1 LASER product. The CLASS 1 LASER PRODUCT MARKING is located on the rear exterior.

The following caution label is located inside of the unit.

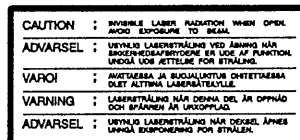

CAUTION
Use of controls or adjustments or performance of procedures other than those specified herein may result in hazardous radiation exposure.

SERVICING NOTES

NOTES ON HANDLING THE OPTICAL PICK-UP BLOCK OR BASE UNIT

The laser diode in the optical pick-up block may suffer electrostatic breakdown because of the potential difference generated by the charged electrostatic load, etc. on clothing and the human body.

During repair, pay attention to electrostatic breakdown and also use the procedure in the printed matter which is included in the repair parts.

The flexible board is easily damaged and should be handled with care.

NOTES ON LASER DIODE EMISSION CHECK

The laser beam on this model is concentrated so as to be focused on the disc reflective surface by the objective lens in the optical pick-up block. Therefore, when checking the laser diode emission, observe more than 30 cm away from the objective lens.

LASER DIODE AND FOCUS SEARCH OPERATION CHECK

1. Make POWER switch on with no disc inserted and disc table closed.
2. Confirm that the following operation is performed while observing the objective lens.

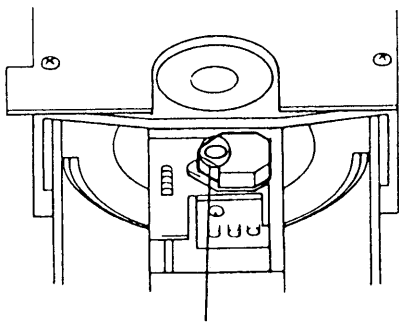

- ① Confirm that laser beam is spread.
- ② Up and downmotion of the objective lens. (3 times)

SECTION 1 GENERAL

• Location of Controls

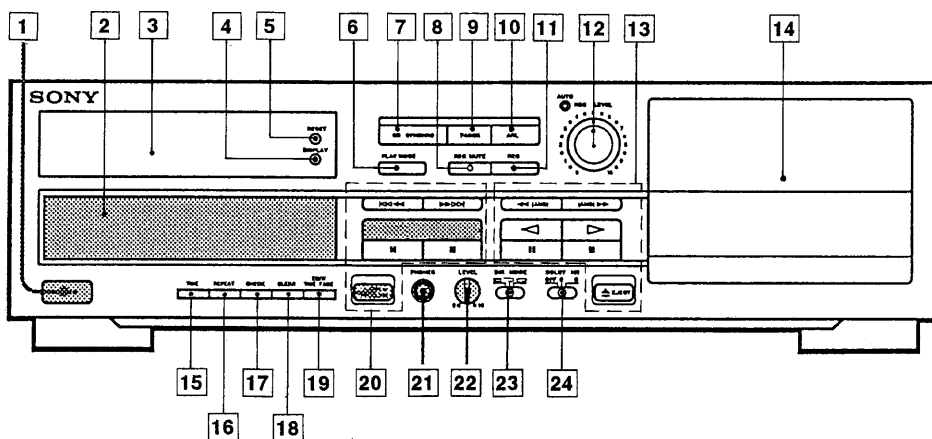

- | | |
|--|--|
| <p>1 POWER button</p> <p>2 Disc tray</p> <p>3 Display window</p> <p>4 DISPLAY butto</p> <p>5 RESET button</p> <p>6 PLAY MODE button</p> <p>7 CD SYNCHRO button</p> <p>8 REC MUTE button</p> <p>9 FADER button</p> <p>10 ARL button</p> <p>11 REC button</p> <p>12 REC LEVEL control</p> <p>13 Tape operation buttons</p> <p>◀▶ : Fast winding</p> <p>▷ : Forward play</p> <p>◁ : Reverse play</p> <p> : PAUSE</p> <p>■ : STOP</p> <p>△ : EJECT</p> | <p>14 Cassette holder</p> <p>15 TIME button</p> <p>16 REPEAT button</p> <p>17 CHECK button</p> <p>18 CLEAR button</p> <p>19 EDIT/TIME FADE button</p> <p>20 CD operation button</p> <p>△ : OPEN/CLOSE</p> <p> : PAUSE</p> <p>■ : STOP</p> <p>▷ : PLAY</p> <p>◀▶ : Manual search</p> <p>21 PHONES jack</p> <p>22 PHONES LEVEL control</p> <p>23 DIR MODE switch</p> <p>24 DOLBY NR switch</p> |
|--|--|

SECTION 2 DISASSEMBLY

Note: Follow the disassembly procedure in the numerical order given.

CASE

Unscrew the four case attachment screw (CASE 3 TP2) and remove the case.

FRONT PANEL

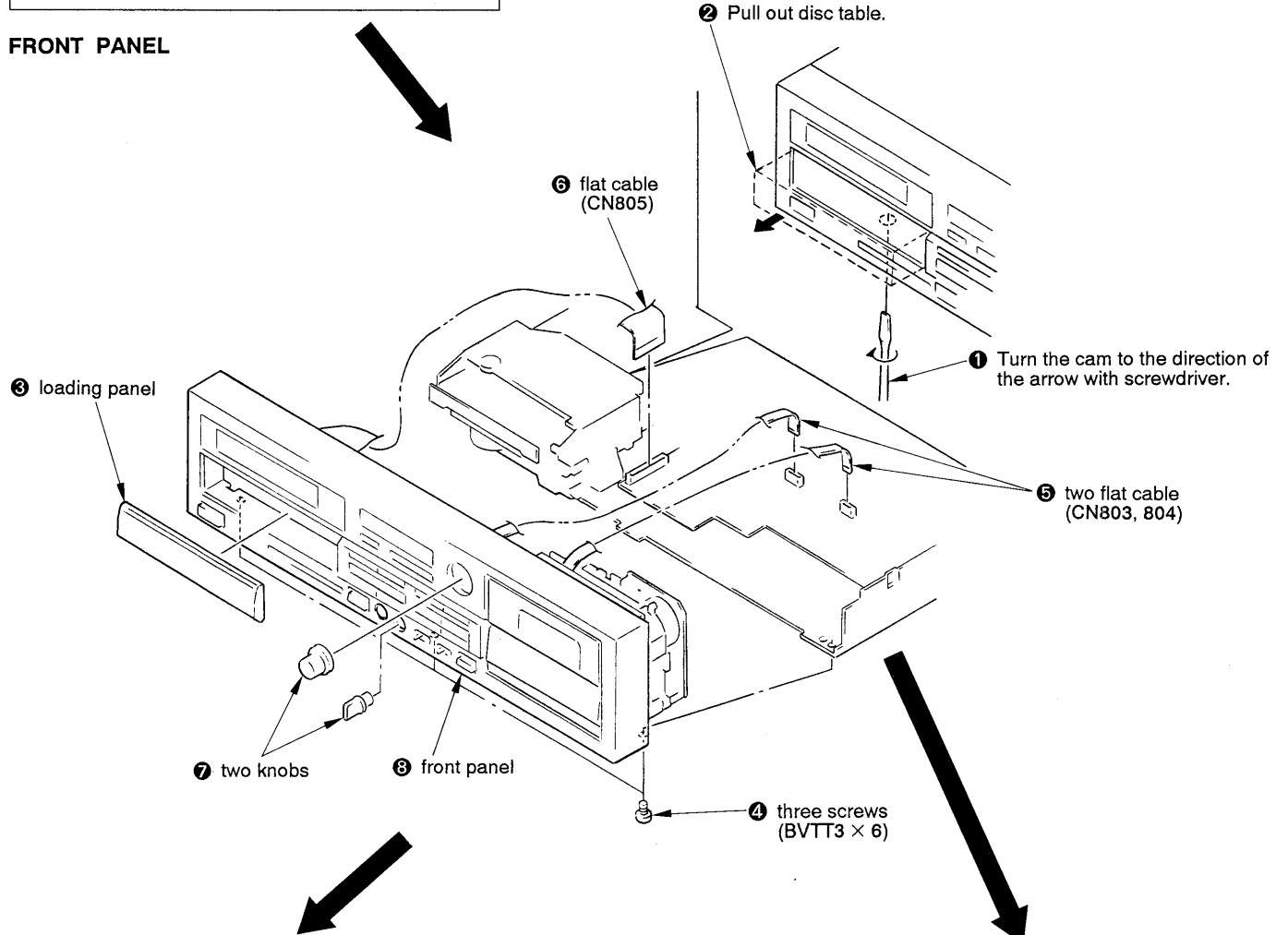

CD UNIT

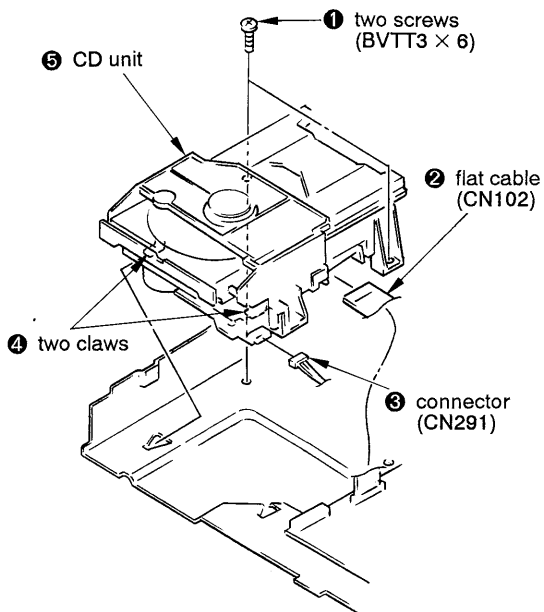

MECHANISM DECK

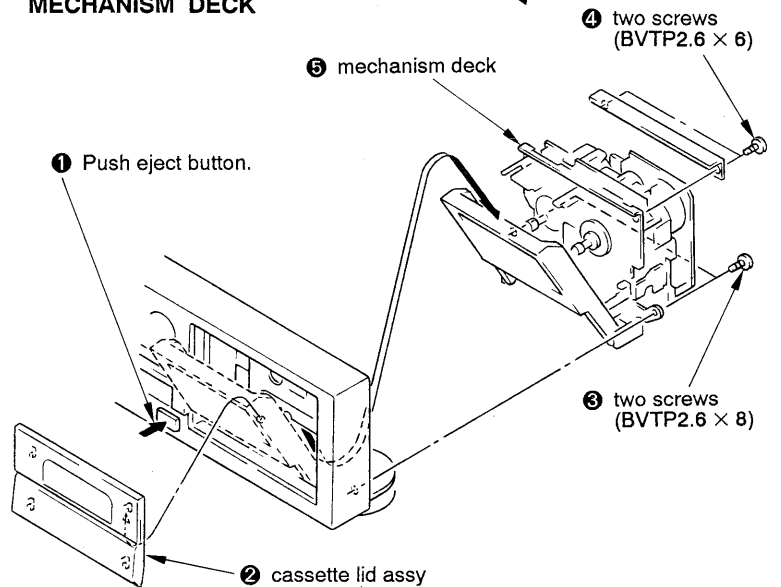

SECTION 3 ADJUSTMENTS

3-1. MECHANICAL ADJUSTMENTS

PRECAUTION

1. Clean the following parts with a denatured alcohol-moistened swab:

record/playback/erase head	pinch roller
rubber belts	capstan
idlers	
2. Demagnetize the record/playback head with a head demagnetizer. (Head demagnetizer do not approach for the erase head.)
3. Do not use a magnetized screwdriver for the adjustment.
4. After the adjustments, apply suitable locking compound to the parts adjusted.
5. The adjustments should be performed with the rated power supply voltage unless otherwise noted.

Torque Measurement

Torque	Torque meter	Meter reading
Forward	CQ-102C	30 to 65 g • cm (0.42 to 0.9 oz • inch)
Forward back tension	CQ-102C	1 to 6 g • cm (0.014 to 0.083 oz • inch)
Reverse	CQ-102RC	30 to 65 g • cm (0.42 to 0.9 oz • inch)
Reverse back tension	CQ-102RC	1 to 6 g • cm (0.014 to 0.083 oz • inch)
FF/REW	CQ-201B	70 to 120 g • cm (0.98 to 1.66 oz • inch)

3-2. ELECTRICAL ADJUSTMENTS

TAPE SECTION

PRECAUTION

1. The adjustment should be performed in the publication. (Be sure to make playback adjustment at first.)
2. The adjustments and measurement should be performed for both L-CH and R-CH.
 - Switch position

DOLBY NR switch	: OFF
DIR MODE switch	: \rightleftharpoons
 - Standard record position :

Deliver the standard input signal level to input jack and set the REC LEVEL control to obtain the standard output signal level as follows.

— Record Mode —

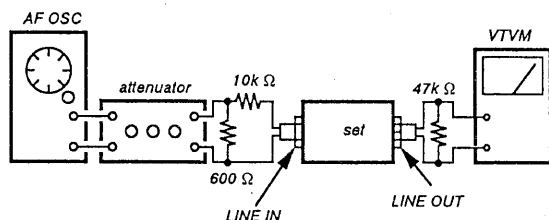

Standard Input Level

Input terminal	LINE IN
source impedance	10k Ω
input signal level	0.5V (- 3.8dB)

Standard Output Level

Output terminal	LINE OUT
load impedance	47k Ω
output signal level	0.5V (- 3.8dB)

Test Tape

Tape	Contents	Use
P-4-A100	10kHz, - 10dB	Azimuth Adjustment
P-4-L300	315Hz, 0dB	PB Level Adjustment
WS-48B	3kHz, 0dB	Tape Speed Adjustment

0dB=0.775V

Test Mode

1. Insert a short-circuit plug into TP801 (2P) and turn ON the power switch. (Earth pin ⑩ of IC801 and turn ON the power switch.)
At first, all the fluorescent tubes light up, then the system returns to normal display. (However, "0000" is not displayed on the counter.)
2. To release the test mode, remove the short plug and turn off the power switch.
3. Remove the short plug after completion of adjustment.

Record/Playback Head Azimuth Adjustment

Procedure :

1. Forward playback Mode

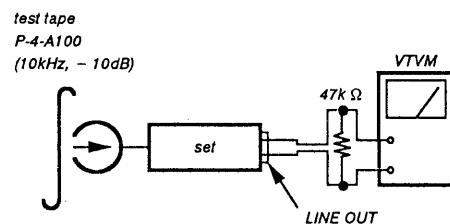

2. Turn the adjustment screw for the maximum output levels. If these levels do not match, turn the adjustment screw until both of output levels match together within 1dB.

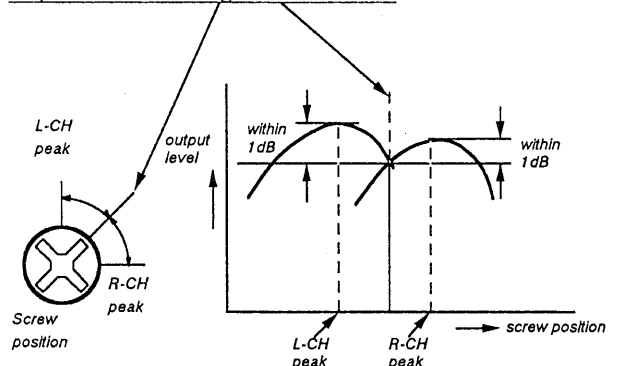

3. Playback Mode

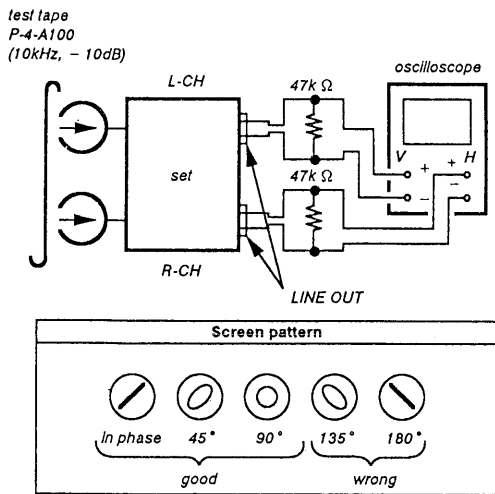

4. Change the reverse playback mode and repeat the steps 1 to 3.
5. After the adjustment, lock the adjustment screws with suitable locking compound.

Adjustment Location : – record/playback head –

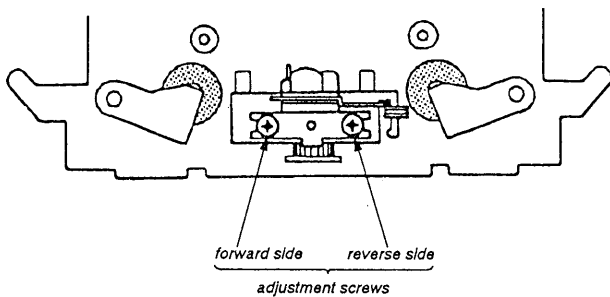

Tape Speed Adjustment

Procedure :

– Forward Playback Mode –

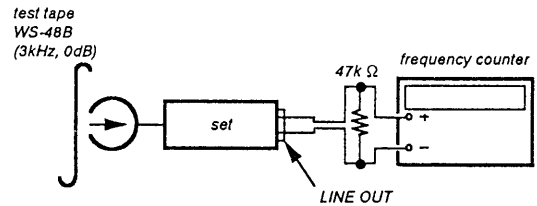

1. Set to FWD playback mode.
2. Adjust RV71 so that the frequency counter reading becomes $3,000 \pm 10\text{Hz}$.

Frequency difference between the beginning and the end of the tape should be within 3%.

Adjustment Location : AUDIO board

Playback Level Adjustment

Procedure :

– Forward Playback Mode –

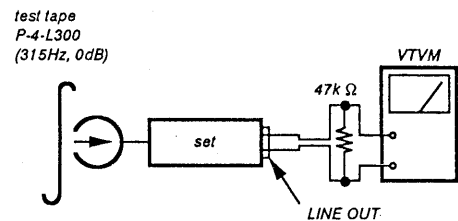

Adjust RV11(L-CH) and RV21(R-CH) so the VTVM reading becomes the adjustment limits below.

Adjustment Value :

LINE OUT level : $-7.7 \pm 0.5\text{dB}$ (0.301 to 0.338V)

Level difference between channels : within 0.5dB

Confirm the LINE OUT level does not change in playback mode while changing the mode from playback to stop several times.

Adjustment Location : AUDIO board

Record Bias Adjustment

Setting :

REC LEVEL control : standard record position (Refer to page 6.)

Procedure :

1. Record Mode

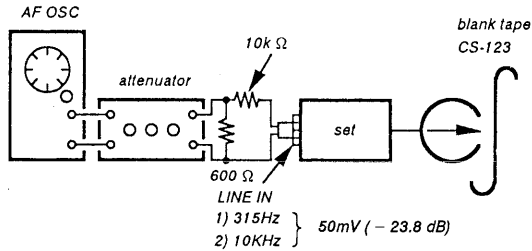

2. Playback Mode

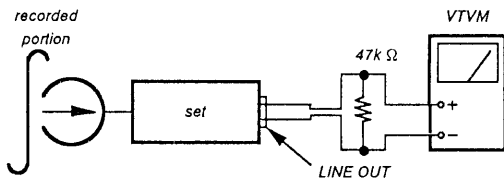

Confirm that the 10kHz playback output is $0 \pm 0.5\text{dB}$ relative to the 315Hz output. If necessary, adjust RV12 (L-CH), RV22 (R-CH) and repeat the steps given above.

Adjustment Location : AUDIO board

Record Level Adjustment

Setting :

REC LEVEL control : standard record position (Refer to page 6.)

Procedure :

1. Record Mode

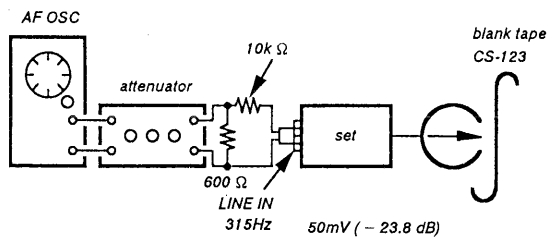

2. Playback Mode

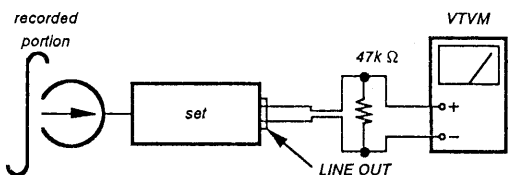

Confirm playback the tape recorded become adjustment level as follows.

If necessary, adjust RV111 (L-CH), RV211 (R-CH) and repeat the steps 1 and 2.

Adjustment Value :

LINE OUT level : $-23.8 \pm 0.5\text{ dB}$ (47.2 to 53.0 mV)

Adjustment Location : MAIN board

– Adjustment Parts Location Diagrams –

[MAIN BOARD]

(Component Side)

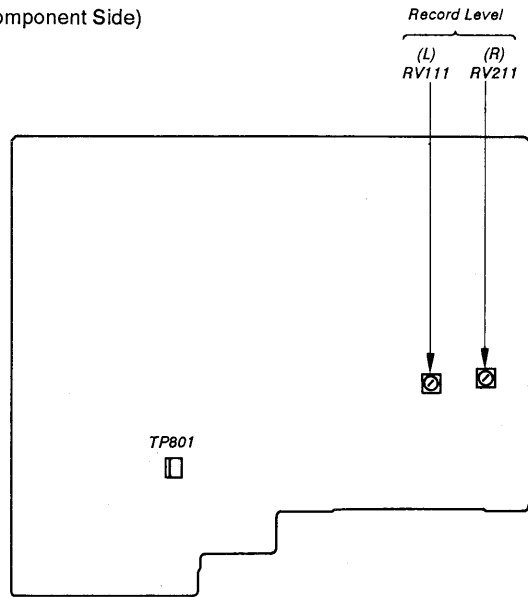

[AUDIO BOARD]

(Conductor Side)

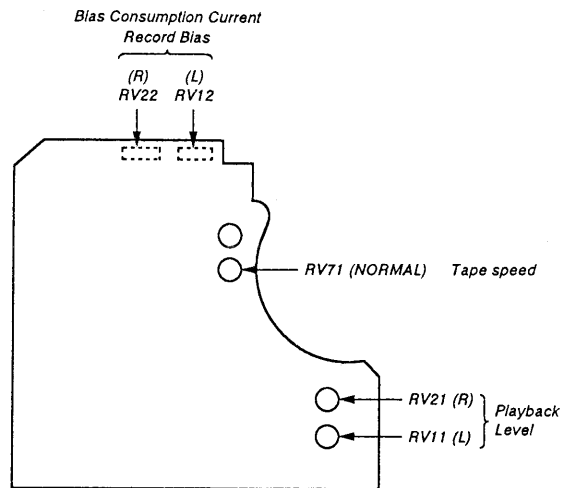

CD SECTION

Note :

1. CD Block basically constructed to operate without adjustment. Therefore, check each item in order given.
2. Use YEDS-18 disc (3-702-101-01) unless otherwise indicated.
3. Use the oscilloscope with more than $10M\Omega$ impedance.
4. Clean an object lens by an applicator with neutral detergent when the signal level is low than specified value with the following checks.

S-Curve Check

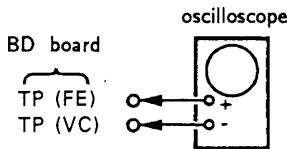

Procedure :

1. Connect oscilloscope to test point TP (FE) on BD board.
2. Connect between test point TP (FEI) and TP (VC) by lead wire.
3. Turned Power switch on.
4. Put disc (YEDS-18) in and turned Power switch on again and actuate the focus search. (actuate the focus search when disc table is moving in and out.)
5. Check the oscilloscope waveform (S-curve) is symmetrical between A and B. And confirm peak to peak level within $3\pm 1V_{p-p}$.

S-curve waveform

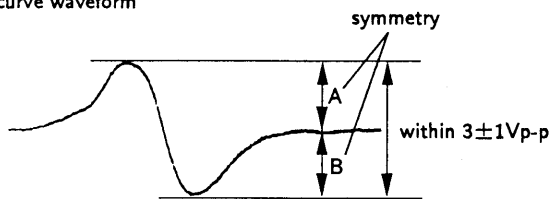

6. After check, remove the lead wire connected in step 2.
- Note :**
- Try to measure several times to make sure that the ratio of A : B or B : A is more than 10 : 7.
 - Take sweep time as long as possible and light up the brightness to obtain best waveform.

RF Level Check

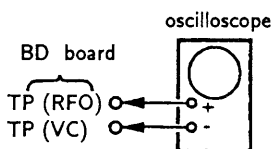

Procedure :

1. Connect oscilloscope to test point TP (RFO) on BD board.
2. Turned Power switch on.

3. Put disc (YEDS-18) in and playback.
4. Confirm that oscilloscope waveform is clear and check RF signal level is correct or not.

Note :

Clear RF signal waveform means that the shape "◇" can be clearly distinguished at the center of the waveform.

RF signal waveform

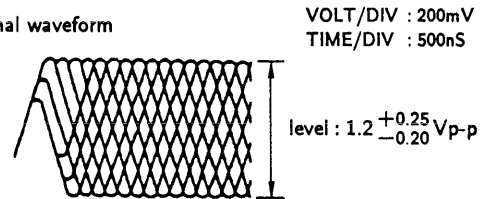

E-F Balance Check

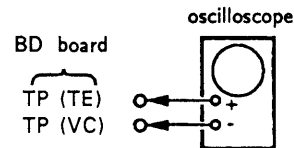

Procedure :

1. Connect JW146 (ADJ) to JW145 (GND) and TP (TEI) to TP (VC) with lead wire.
2. Connect oscilloscope to test point TP (TE) on BD board.
3. Turned Power switch on.
4. Put disc (YEDS-18) in and playback.
5. Confirm that the oscilloscope waveform is symmetrical on the top and bottom in relation to 0V, and check this level.

Traverse waveform



6. Remove the lead wire connected in step 1.

RF PLL Free-run Frequency Check

Procedure :

1. Connect frequency counter to test point (PLCK) with lead wire.

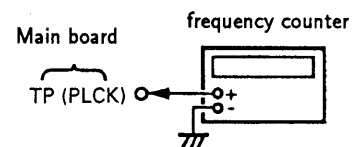

2. Turned Power switch on.
3. Confirm that reading on frequency counter is 4.3218MHz.

Adjustment Location:

[BD BOARD]
(Conductor Side)

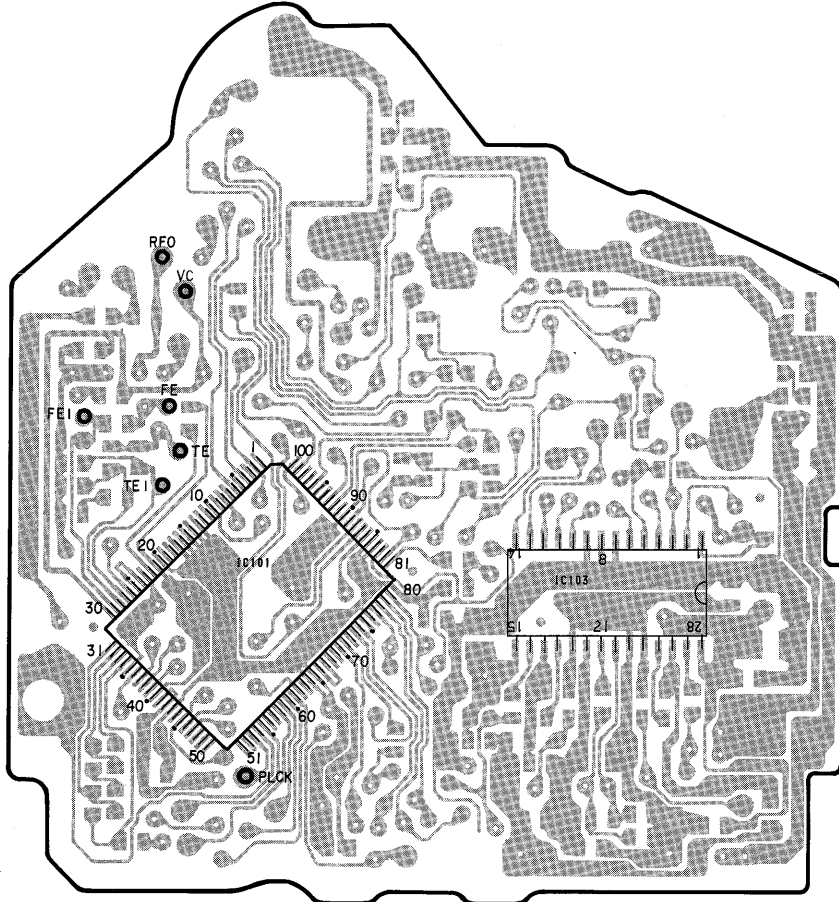

[MAIN BOARD]
(Component Side)

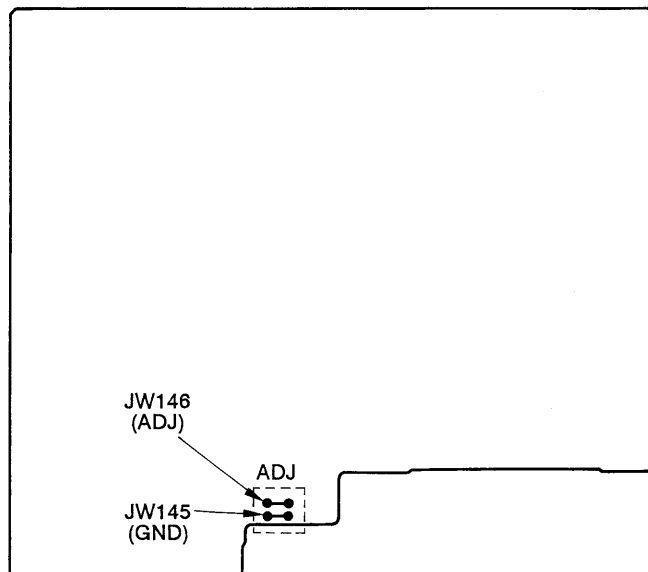

SECTION 4
DIAGRAMS

• Circuit Boards Location

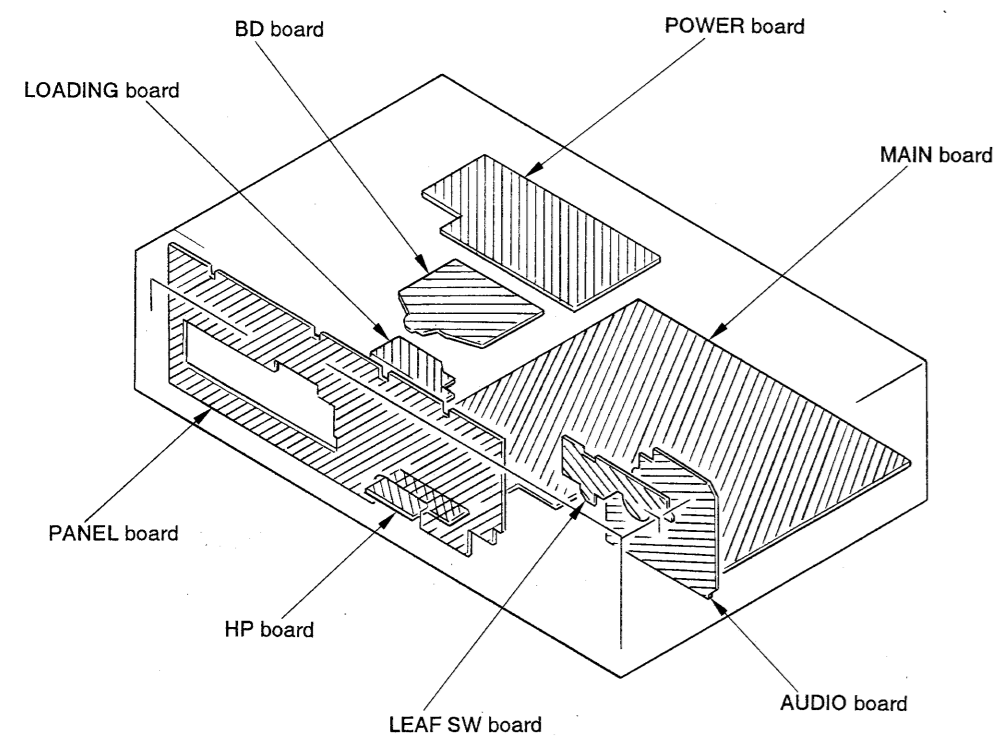

• Semiconductor Location

Ref. No.	Location
D901	B-10
IC31	F-3
IC32	F-4
IC81	K-6
IC101	J-10
IC102	I-16
IC103	J-12
IC901	B-15
Q51	D-4
Q52	D-4
Q53	E-4
Q71	E-6

4-1. PRINTED WIRING BOARDS - PANEL and MECHANISM Section -

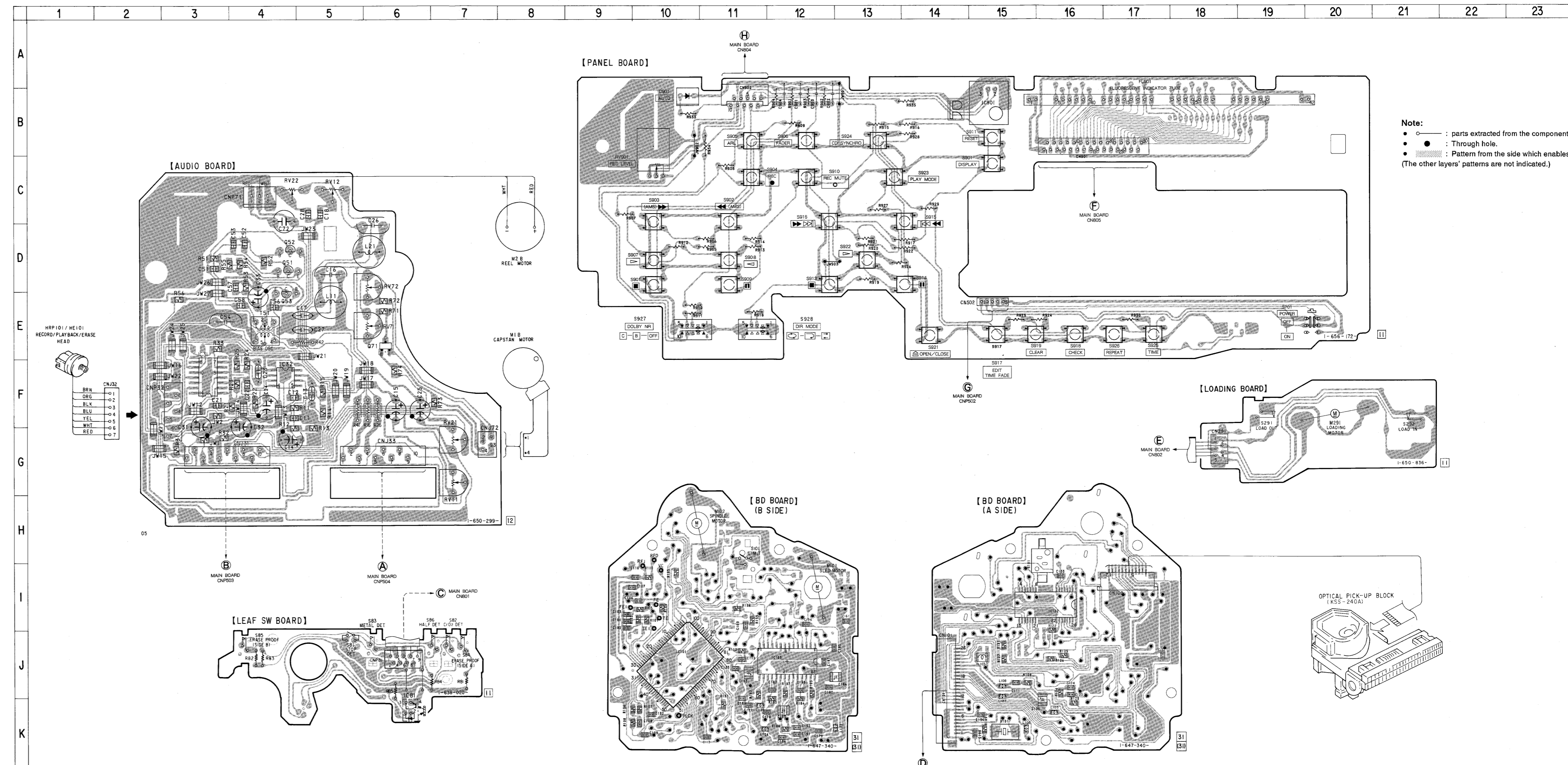

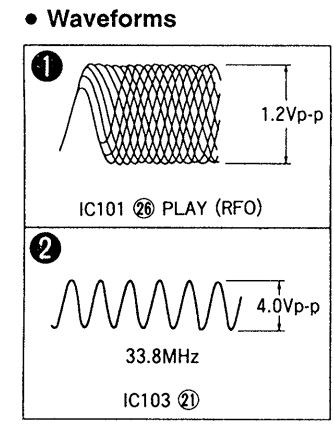
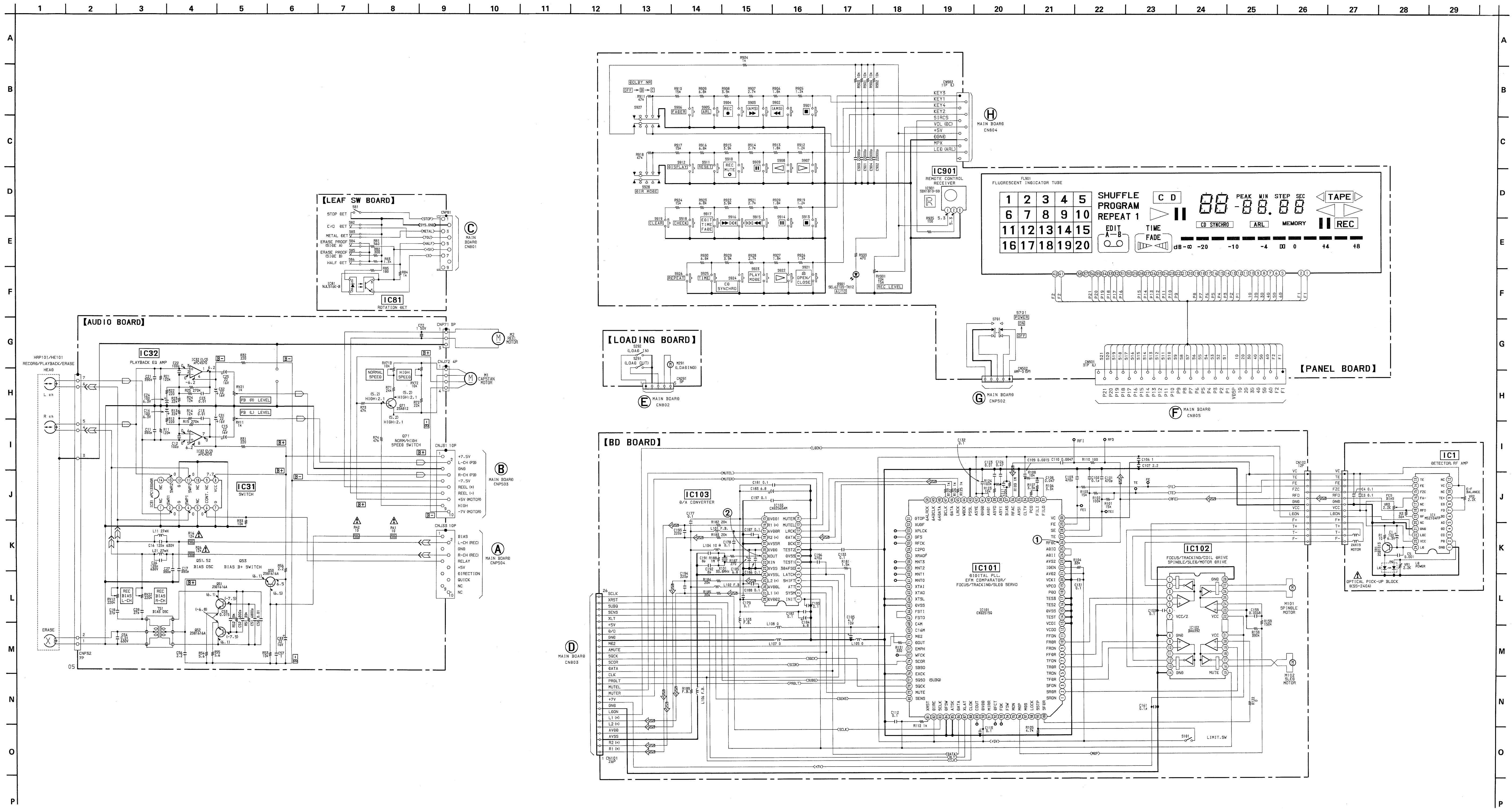

Note:

- All capacitors are in μF unless otherwise noted. pF, μF 50 WV or less are not indicated except for electrolytics and tantalums.
- All resistors are in Ω and $\frac{1}{2} \text{W}$ or less unless otherwise specified.
- : nonflammable resistor.

Note: The components identified by mark or dotted line with mark are critical for safety. Replace only with part number specified.

Note: Les composants identifiés par une marque ou une ligne pointillée avec la marque sont critiques pour la sécurité. Ne les remplacer que par une pièce portant le numéro spécifié.

- : B+ Line.
- : B- Line.
- : panel designation.
- : adjustment for repair.
- Volts are dc with respect to ground under no-signal conditions.
- Volts are taken with a VOM (10 M Ω /V).
- Voltage variations may be noted due to normal production tolerances.
- Signal path.
- : PB
- : REC
- : CD

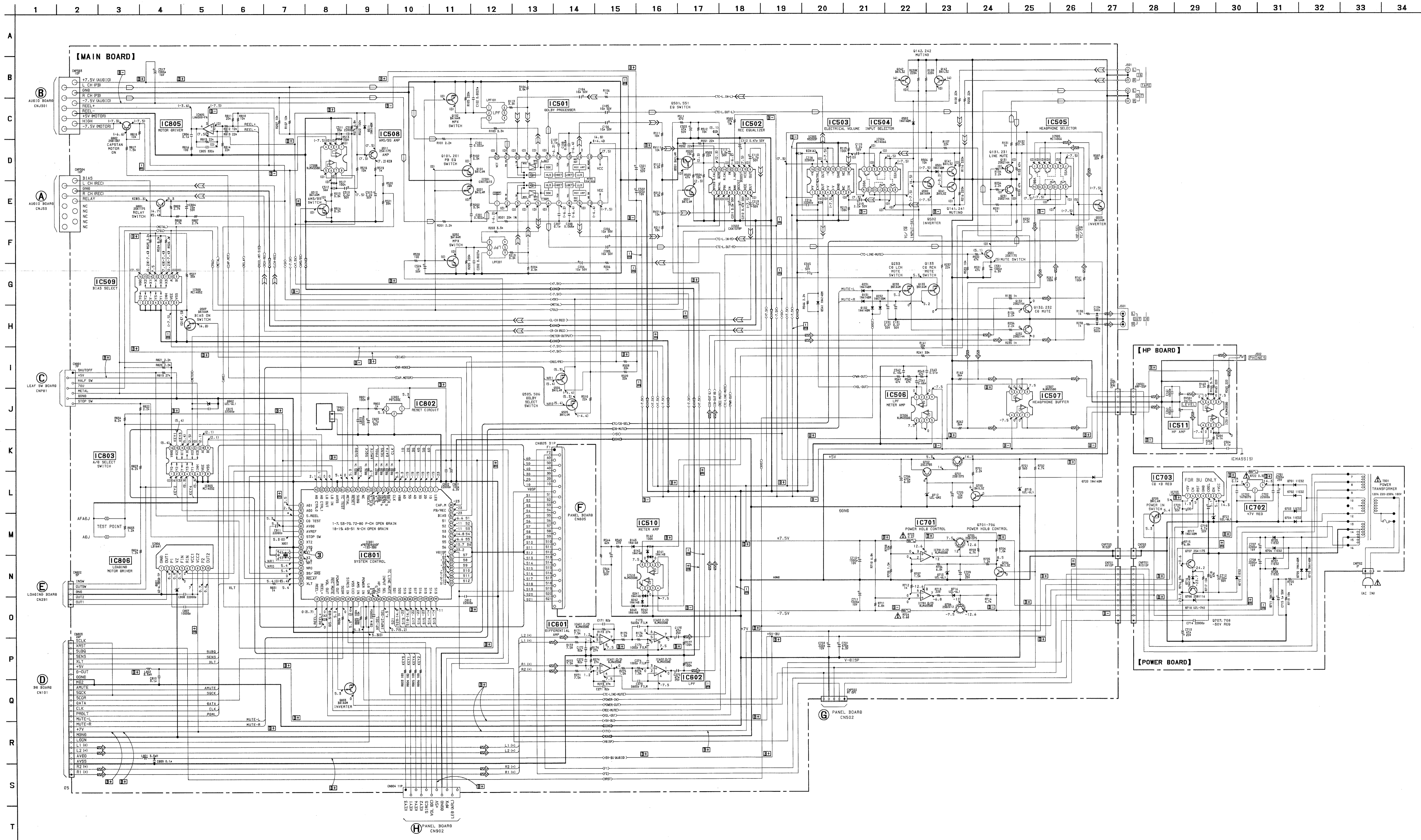

• Waveform

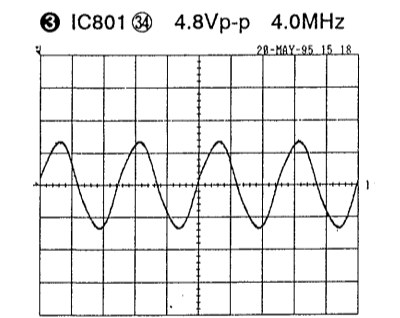

- Note:
- All capacitors are in μF unless otherwise noted, μF , μF 50 WV or less are not indicated except for electrolytics and tantalums.
 - All resistors are in Ω and $\frac{1}{4}$ W or less unless otherwise specified.
 - Δ : internal component.
 - $\text{---}/\text{---}$: fusible resistor.

Note: The components identified by mark Δ or dotted line with mark Δ are critical for safety. Replace only with part number specified.

Note: Les composants identifiés par une marque Δ sont critiques pour la sécurité. Ne les remplacer que par une pièce portant le numéro spécifié.

- $\text{---}+$: B+ Line.
- $\text{---}-$: B- Line.
- --- : panel designation.
- --- : adjustment for repair.
- Voltages and waveforms are dc with respect to ground under no-signal conditions.
- Voltages are taken with a VOM (10 M Ω /V). Voltage variations may be noted due to normal production tolerances.
- Waveforms are taken with an oscilloscope. Voltage variations may be noted due to normal production tolerances.
- Circled numbers refer to waveforms.
- Signal path.
- --- : PB
- --- : REC
- --- : CD

• Semiconductor Location

Ref. No.	Location	Ref. No.	Location
D131	G-9	IC511	G-14
D132	D-9	IC601	F-9
D141	D-8	IC602	E-9
D142	D-8	IC701	B-9
D143	D-7	IC702	B-13
D231	G-8	IC703	B-13
D232	D-8	IC801	I-8
D241	D-7	IC802	H-9
D242	D-7	IC803	H-6
D243	D-7	IC805	G-5
D501	C-4	IC806	E-10
D502	D-3		
D511	E-5	Q101	E-3
D541	F-7	Q102	F-3
D701	C-14	Q131	C-4
D702	C-14	Q132	E-9
D703	C-14	Q133	D-9
D704	C-14	Q141	C-3
D705	D-14	Q142	D-3
D706	D-14	Q201	E-3
D707	D-14	Q202	E-1
D708	D-14	Q231	C-5
D709	C-14	Q233	F-8
D710	C-14	Q241	C-3
D711	C-12	Q242	D-3
D712	B-8	Q501	H-2
D713	B-9	Q502	D-4
D714	B-10	Q503	E-5
D715	D-14	Q505	E-4
D716	D-13	Q506	E-4
D717	C-12	Q507	G-4
D718	B-14	Q511	F-5
D719	C-9	Q512	D-5
D720	C-7	Q531	C-5
D721	C-12	Q551	H-2
D801	E-10	Q701	A-8
D802	G-6	Q702	B-8
		Q703	C-8
		Q704	C-9
IC501	D-2	Q705	A-9
IC502	G-2	Q706	A-10
IC503	B-1	Q707	D-13
IC504	D-4	Q708	D-12
IC505	D-5	Q709	C-12
IC506	F-8	Q801	H-5
IC507	D-7	Q802	H-5
IC508	E-4	Q803	H-7
IC509	G-4		
IC510	F-8		

Note:
 • ○ : parts extracted from the component side.

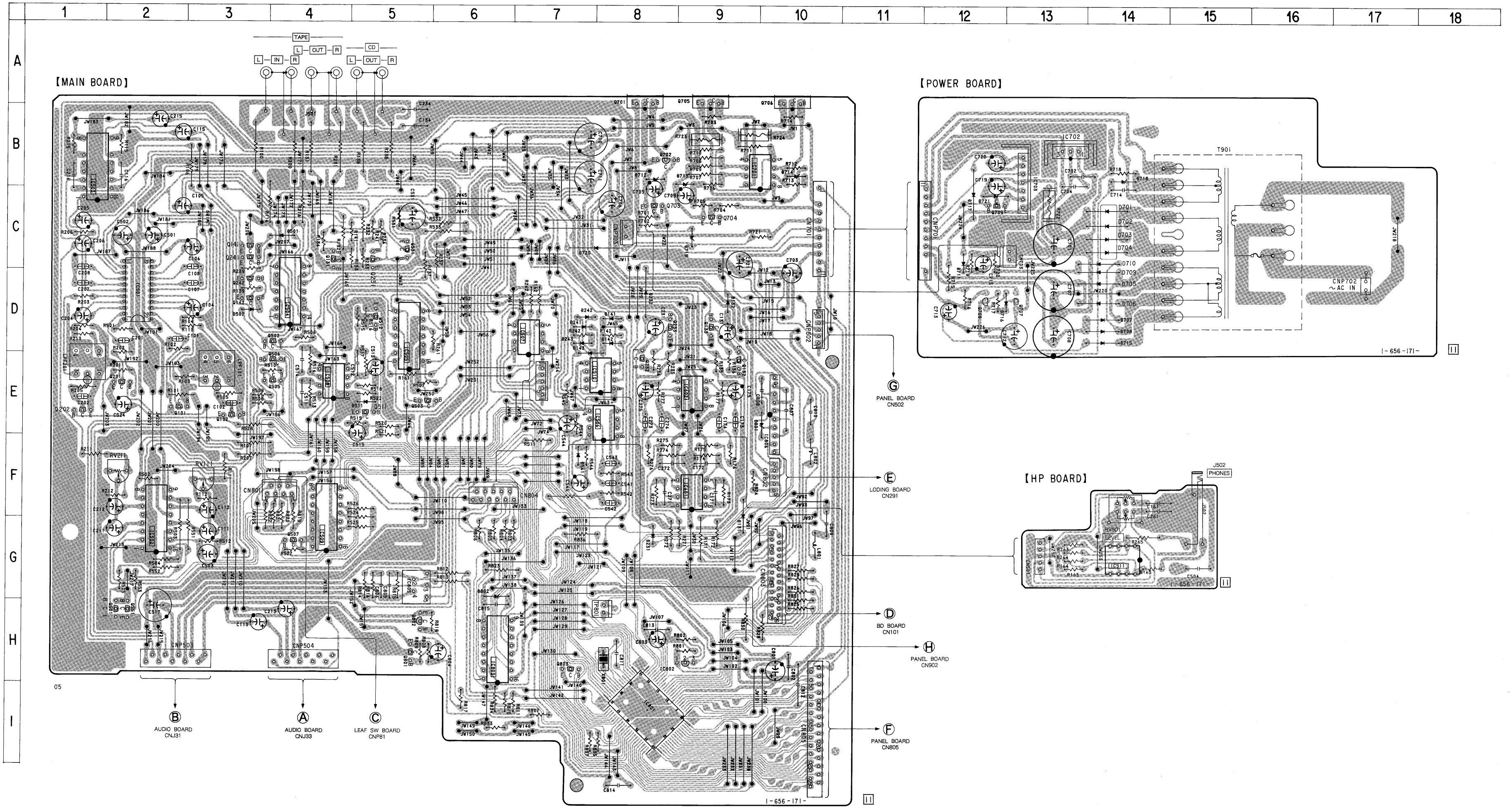

4-5. IC PIN FUNCTION DESCRIPTION

IC801 μ PD78044AGF-133-3B9

Pin No.	Pin Name	I/O	Function
1	LED	O	Auto Rec Level indicate LED ON output ("H": ON)
2	1G	O	FL tube grid output (6G)
3	2G	O	FL tube grid output (5G)
4	3G	O	FL tube grid output (4G)
5	4G	O	FL tube grid output (3G)
6	5G	O	FL tube grid output (2G)
7	6G	O	FL tube grid output (1G)
8	VDD	—	Power supply pin (+5 V)
9	CLK	O	Serial clock output to CDM (IC101, 103)
10	DATA	O	Serial data output to CDM (IC101, 103)
11	SENS	I	SENS signal input from CDM (IC101)
12	PGML	O	Latch clock (PRGLT) output to CDM (IC103)
13	AMUTE	O	CD mute ON output to CDM (IC101, 103). ("L": MUTE)
14	SQCLK	O	SUB-Q code serial clock output to CDM (IC101)
15	NC	—	Not used
16	SUBQ	I	SUB-Q code serial data input from CDM (IC101)
17	RESET	I	Reset input ("L": RESET)
18	METAL	I	TYPE IV cassette detect switch input
19	TC TEST	I	DECK TEST pin ("L": DECK TEST MODE)
20	AVSS	—	GND
21	LD IN	O	Loading motor rotation direction control output (OUT direction)
22	LD OUT	O	Loading motor rotation direction control output (IN direction)
23	AD CTRL1	O	A/D select output to Selector (IC803)
24	AD CTRL0	O	
25	AD1	I	A/D input from Selector (IC803)
26	AD0	I	
27	S. REEL	I	S-REEL pulse input (A/D)
28	CD TEST	I	CD TEST pin (A/D). → See other description
29	AVDD	—	Power supply pin (+5 V)
30	AVREF	—	Reference voltage pin (+5 V)
31	STOP SW	I	DECK stop switch input ("H": STOP)
32	XT2	—	Not used
33	VSS	—	GND
34	X1	I	System clock input pin
35	X2	—	System clock
36	NR1	O	DOLBY NR mode control output. → See other description
37	NR0	O	
38	BS/AMS	O	DECK AMS/BS amp select output ("L": AMS, "H": BS)
39	RELAY	O	DECK REC/PB head relay select output ("L": REC, "H": PB)
40	XLT	O	Latch output to CDM (IC101)

Pin No.	Pin Name	I/O	Function
41	REEL -	O	DECK reel motor rotation direction control output (to amp "-")
42	REEL +	O	DECK reel motor rotation direction control output (to amp "+")
43	VOL OUT	O	Input level control output (PWM) to LPF (IC506)
44	REC MUTE	O	REC MUTE ON output ("L": MUTE)
45	POWER OUT	O	Power hold control output ("H": HOLD)
46	SCOR	I	SCOR input from CDM (IC101)
47	SIRCS IN	I	SIRCS input
48	VSS (IC)	—	GND
49	AMS IN	I	AMS signal input ("L": BLANK, "H": MUSIC)
50	POWER IN	I	Power switch input ("L": OFF)
51	LD ON	O	Laser Diode ON output to CDM (IC1). ("H": ON)
52	VDD	—	Power supply pin (+5 V)
53	HP SEL	O	Headphone output select ("L": CD, "H": TAPE)
54	INPUT SEL	O	DECK Input select ("L": CD, "H": LINE IN)
55	TC LINE MUTE	O	DECK Line mute ON output ("L": MUTE)
56	S21	O	FL tube segment output (S21)
57	S20	O	FL tube segment output (S20)
58	S19	O	FL tube segment output (S19)
59	S18	O	FL tube segment output (S18)
60	S17	O	FL tube segment output (S17)
61	S16	O	FL tube segment output (S16)
62	S15	O	FL tube segment output (S15)
63	S14	O	FL tube segment output (S14)
64	S13	O	FL tube segment output (S13)
65	S12	O	FL tube segment output (S12)
66	S11	O	FL tube segment output (S11)
67	S10	O	FL tube segment output (S10)
68	S9	O	FL tube segment output (S9)
69	S8	O	FL tube segment output (S8)
70	S7	O	FL tube segment output (S7)
71	VDISP	—	Power supply pin (-30 V)
72	S6	O	FL tube segment output (S6)
73	S5	O	FL tube segment output (S5)
74	S4	O	FL tube segment output (S4)
75	S3	O	FL tube segment output (S3)
76	S2	O	FL tube segment output (S2)
77	S1	O	FL tube segment output (S1)
78	BIAS	O	BIAS ON output ("H": ON)
79	PB/REC	O	DOLBY NR REC/PB select output ("L": PB, "H": REC)
80	CAP. M	O	Capstan motor ON output ("H": ON)

● IC Block Diagrams

IC101 CXD2515Q (BD BORAD)

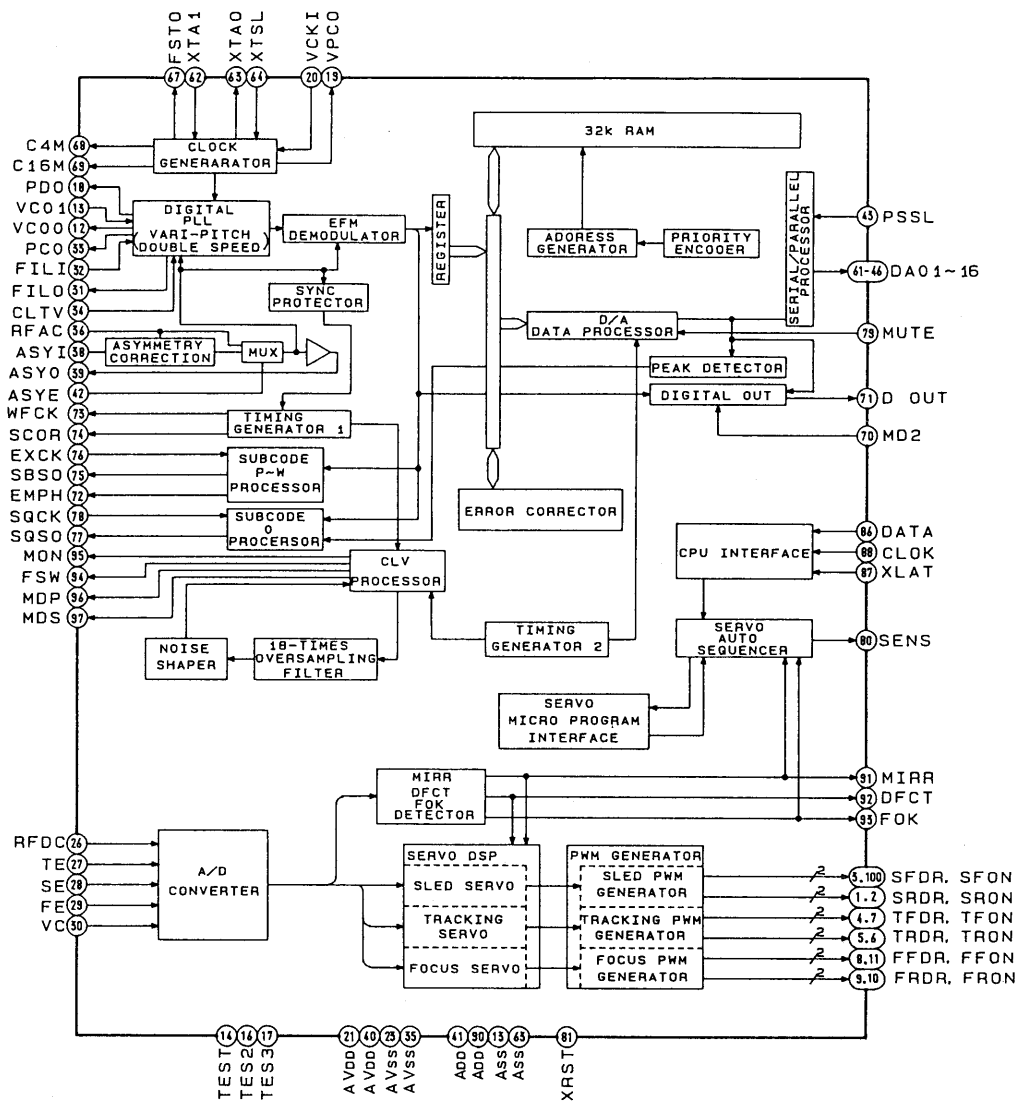

IC502 CXA1578P (MAIN BOARD)

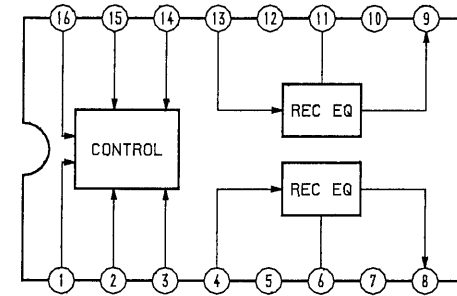

IC503 M5283P (MAIN BOARD)

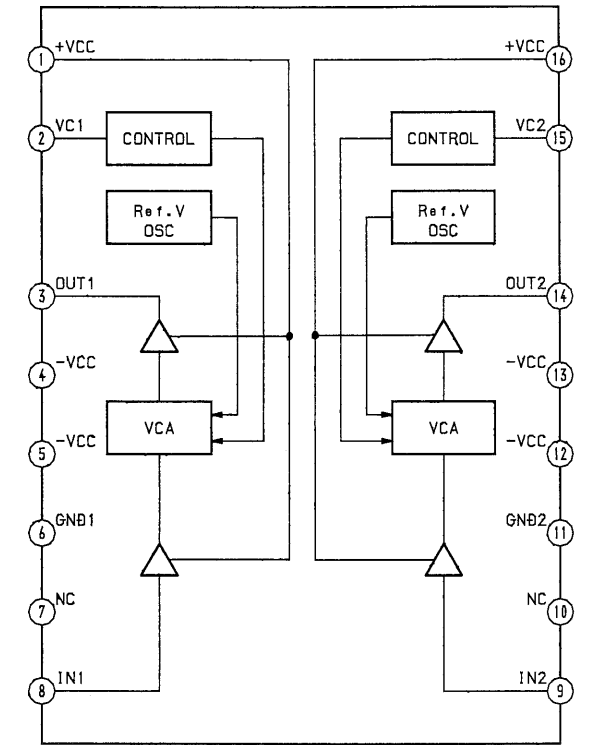

IC103 CXD2565M (BD BOARD)

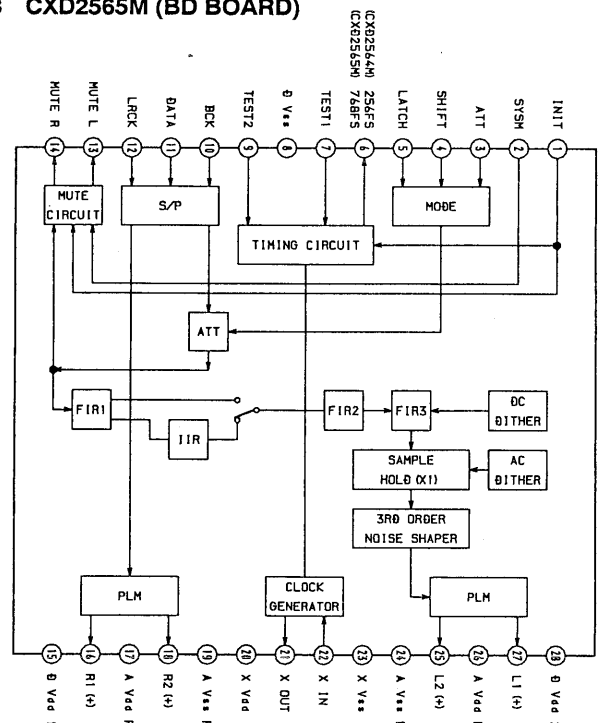

IC31 μPC1330GR (AUDIO BOARD)

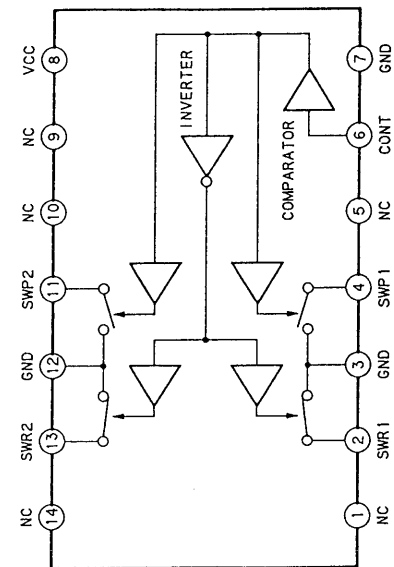

IC703 LA5602 (MAIN BOARD)

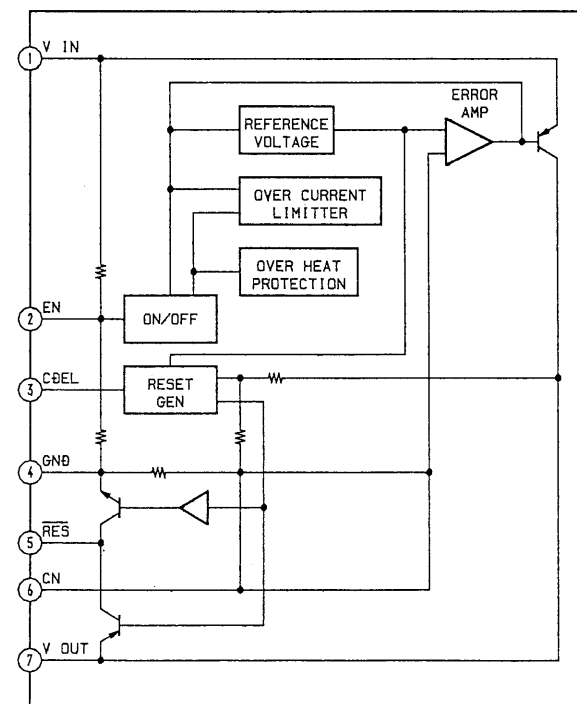

IC806 LB1641 (MAIN BOARD)

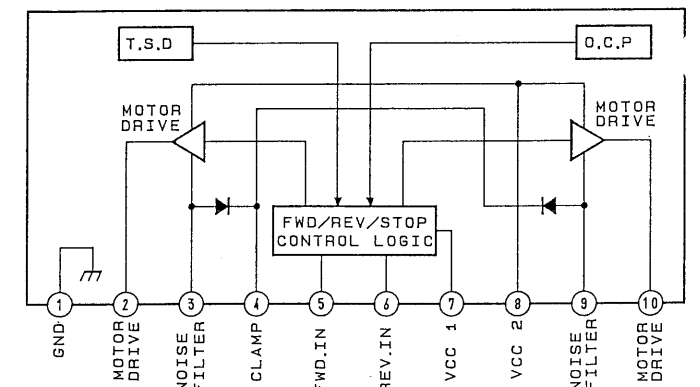

SECTION 5 EXPLODED VIEWS

NOTE:

- -XX and -X mean standardized parts, so they may have some difference from the original one.
- Color Indication of Appearance Parts
Example:
KNOB, BALANCE (WHITE) ... (RED)
↑ ↑
Parts Color Cabinet's Color

- Items marked "*" are not stocked since they are seldom required for routine service. Some delay should be anticipated when ordering these items.
- The mechanical parts with no reference number in the exploded views are not supplied.
- Hardware (# mark) list and accessories and packing materials are given in the last of the electrical parts list.

The components identified by mark \triangle or dotted line with mark \triangle are critical for safety. Replace only with part number specified.

Les composants identifiés par une marque \triangle sont critiques pour la sécurité. Ne les remplacer que par une pièce portant le numéro spécifié.

(1) CABINET SECTION

- A: POWER BOARD
- B: HP BOARD

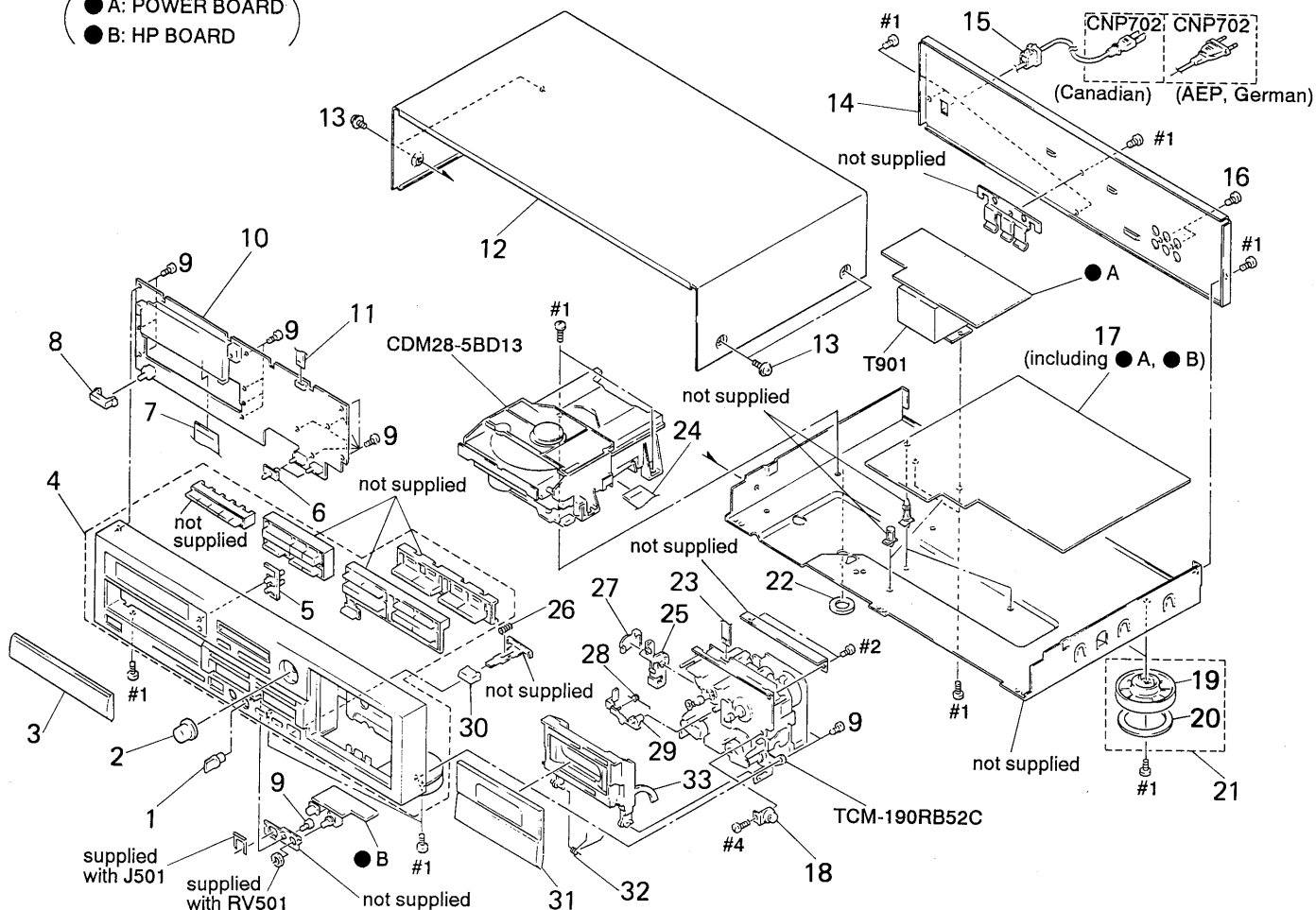

Ref. No.	Part No.	Description	Remark
1	3-354-931-01	KNOB (DIA. 10)	
2	3-909-661-01	KNOB (REC)	
3	3-923-299-01	PANEL, LOADING	
4	X-3370-091-1	PANEL ASSY, FRONT (AEP, German)	
4	X-3370-151-1	PANEL ASSY, FRONT (Canadian)	
5	3-922-832-01	BUTTON (COUNTER)	
6	3-917-216-11	KNOB (TIMER)	
7	1-775-368-11	WIRE (FLAT TYPE) (31 CORE)	
8	3-354-932-01	BUTTON (POWER)	
9	4-951-620-01	SCREW (2.6X8), +BVT	
* 10	A-2007-414-A	PANEL BOARD, COMPLETE	
11	1-775-369-11	WIRE (FLAT TYPE) (11 CORE)	
* 12	4-943-088-41	CASE	
13	3-363-099-01	SCREW (CASE 3 TP2)	
* 14	3-923-319-01	PANEL, BACK (Canadian)	
* 14	3-923-319-11	PANEL, BACK (AEP, German)	
* 15	3-703-244-00	BUSHING (2104), CORD (AEP, German)	
15	3-703-571-11	BUSHING (S) (4516), CORD (Canadian)	
16	3-704-515-01	SCREW (BV/RING)	
* 17	A-2007-413-A	MAIN BOARD, COMPLETE (Canadian)	
* 17	A-2007-415-A	MAIN BOARD, COMPLETE (AEP, German)	
18	3-354-963-01	DAMPER	

Ref. No.	Part No.	Description	Remark
19	3-318-688-31	FOOT (F58175S) (AEP, German)	
19	3-318-688-51	FOOT (F58175S) (Canadian)	
20	4-923-836-21	CUSHION	
21	X-4941-291-1	FOOT ASSY (F58175S) (Canadian)	
21	X-4941-292-1	FOOT ASSY (F58175S) (AEP, German)	
22	3-302-647-01	WASHER, RUBBER	
23	1-775-370-11	WIRE (FLAT TYPE) (7 CORE)	
24	1-775-371-11	WIRE (FLAT TYPE) (26 CORE)	
* 25	3-354-953-01	LEVER (LOCK LEVER L)	
26	3-382-382-11	SPRING, COMPRESSION	
27	3-354-957-01	JOINT (LOCK LEVER)	
28	3-354-961-01	SPRING (EJ SAFTY SPRING L)	
29	3-354-955-01	LEVER (EJ SAFTY LEVER L)	
30	3-923-306-01	BUTTON (EJECT)	
31	X-3370-158-1	LID ASSY, CASSETTE	
32	4-959-231-11	SPRING (L), TORSION	
33	X-4945-947-1	HOLDER (L) ASSY, CASSETTE	
\triangle CNP702	1-558-945-21	CORD, POWER (POLAR. SPT-1) (Canadian)	
\triangle CNP702	1-575-651-21	CORD, POWER (AEP, German)	
\triangle T901	1-427-909-11	TRANSFORMER, POWER (Canadian)	
\triangle T901	1-427-910-11	TRANSFORMER, POWER (AEP, German)	

(2) MECHANISM SECTION 1
(TCM-190RB52C)

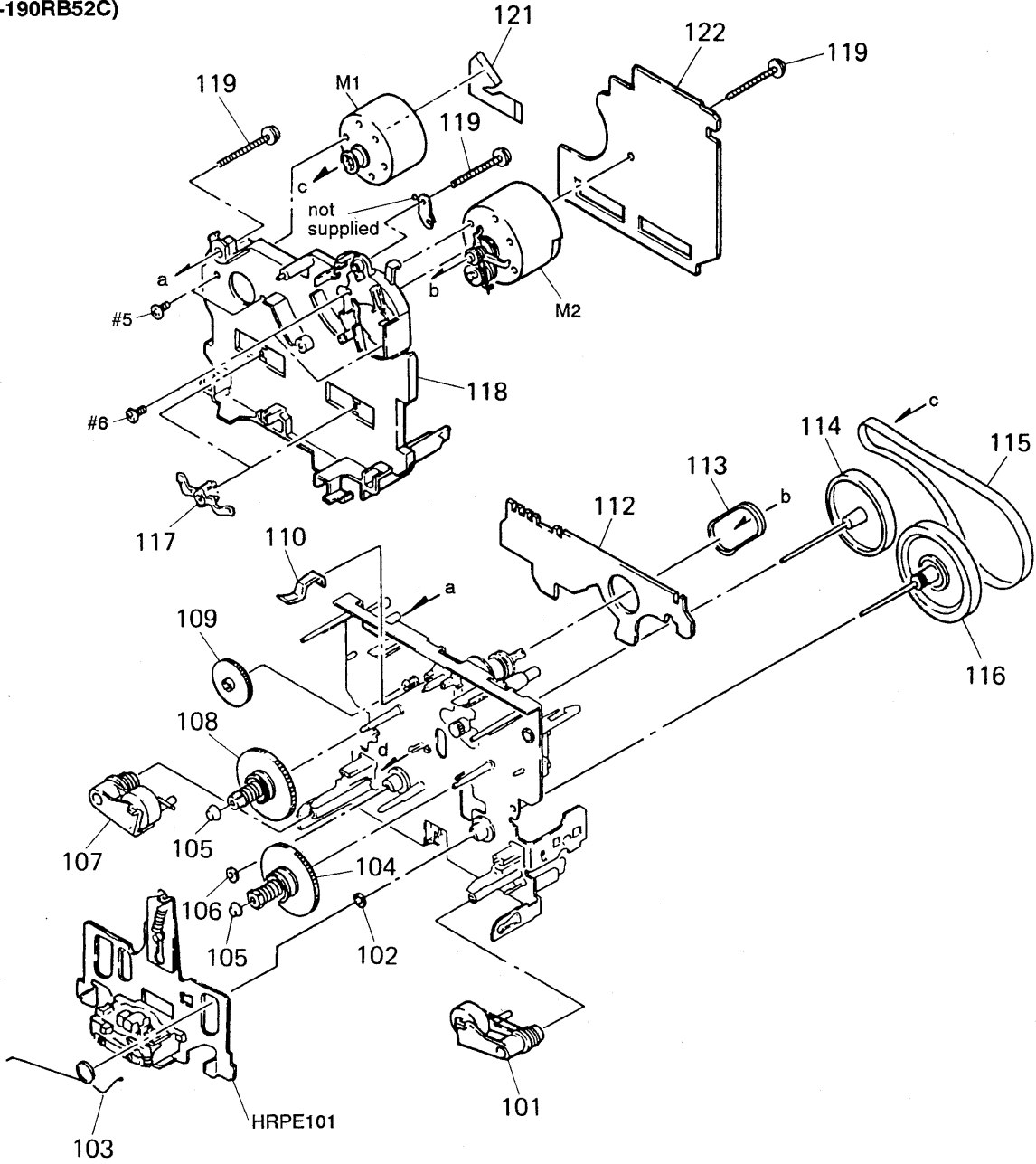

Ref. No.	Part No.	Description	Remark	Ref. No.	Part No.	Description	Remark
101	X-3366-047-1	LEVER (PINCH F) ASSY		114	X-3367-630-1	FLYWHEEL (REV) ASSY	
102	3-356-713-01	WASHER		115	3-359-417-01	BELT (FLAT), CAPSTAN	
103	3-907-362-01	SPRING, TORSION		116	X-3367-629-1	FLYWHEEL (FWD) ASSY	
104	X-3366-970-1	TABLE ASSY, REEL		117	3-575-321-00	RETAINER, THRUST, CAPSTAN	
105	3-362-308-01	CAP (REEL)		118	3-359-436-11	BASE (THRUST RETAINER), FITTING	
106	3-356-714-01	WASHER		119	3-359-414-01	SCREW (+PTPWH 2X23)	
107	X-3366-048-1	LEVER (PINCH R) ASSY		121	1-638-983-11	MOTOR FLEXIBLE	
108	X-3366-971-1	TABLE ASSY (B), REEL		* 122	A-2007-133-A	AUDIO BOARD, COMPLETE	
109	3-359-424-01	GEAR (REV GEAR)		HRPE101A-2003-930-A	DECK ASSY, HEAD (PLAYBACK/RECORD/ERASE)		
110	3-359-430-01	SPRING (CASSETTE RETAINER), LEAF		M1	X-3365-377-2	MOTOR ASSY (CAPSTAN)	
* 112	1-638-020-11	LEAF SW BOARD		M2	X-3363-501-2	MOTOR ASSY (REEL)	
113	3-359-466-01	BELT (FR), SQUARE					

(3) MECHANISM SECTION 2
(TCM-190RB52C)

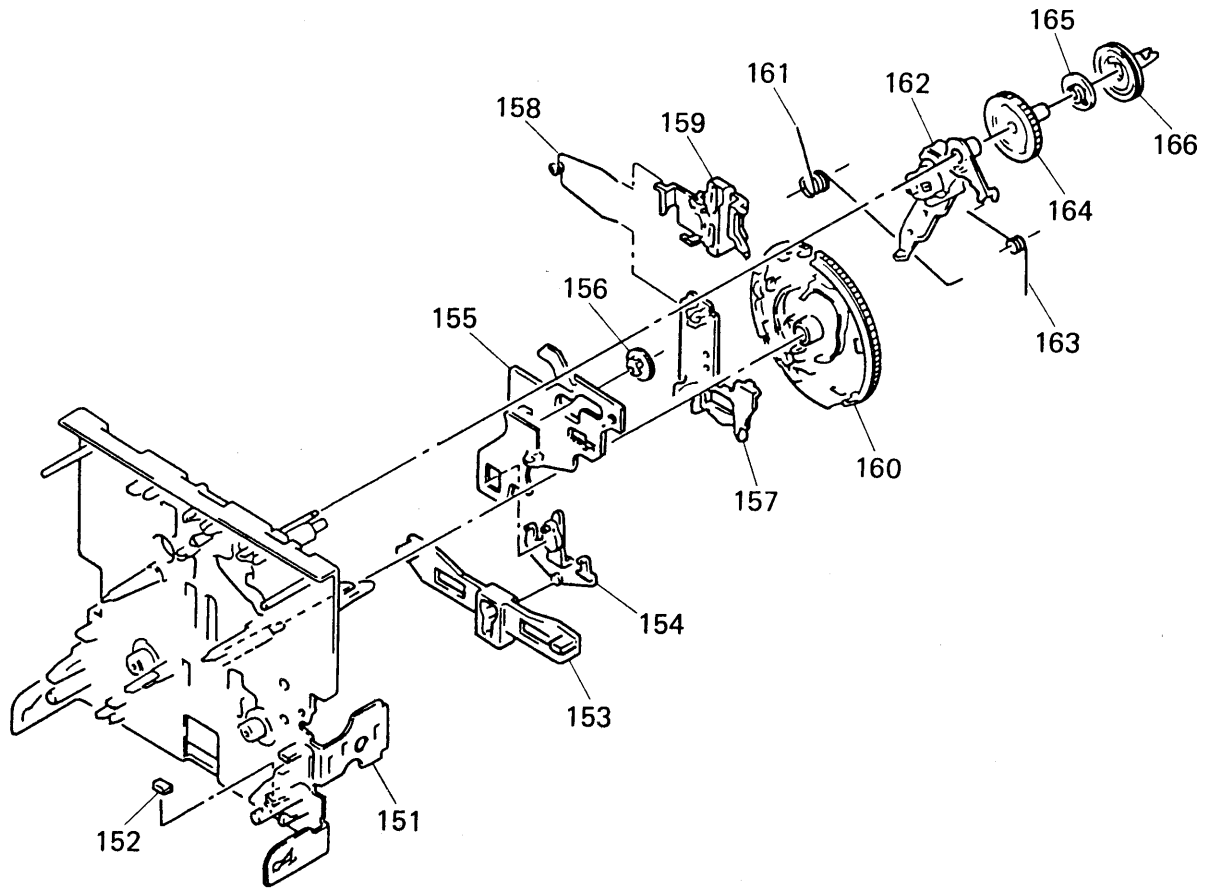

Ref. No.	Part No.	Description	Remark	Ref. No.	Part No.	Description	Remark
151	X-3363-790-1	CHASSIS ASSY, MECHANICAL		159	3-359-429-11	SLIDER (BRAKE PLATE)	
152	3-359-469-01	SPACER		160	3-359-420-01	GEAR (CAM GEAR)	
153	3-359-425-01	SLIDER (REVERSE SLIDER)		161	3-359-456-01	SPRING (TRIGGER SPRING), TORSION	
154	3-359-426-01	LEVER (REVERSE LEVER)		162	X-3366-569-1	ARM ASSY, FR	
155	3-359-415-11	SLIDER (TRIGGER SLIDER)		163	3-924-185-11	SPRING (FR ARM), TORSION	
156	3-359-448-01	GEAR (TRIGGER)		164	3-359-419-11	GEAR (FR GEAR)	
157	3-359-427-01	SLIDER (LEVERSE SLIDER)		165	3-359-421-01	CLUTCH (REEL DISK)	
158	3-359-454-01	SPRING, TORSION		166	3-359-418-01	PULLEY (FR PULLEY)	

(4) CD SECTION
(CDM28-5BD13)

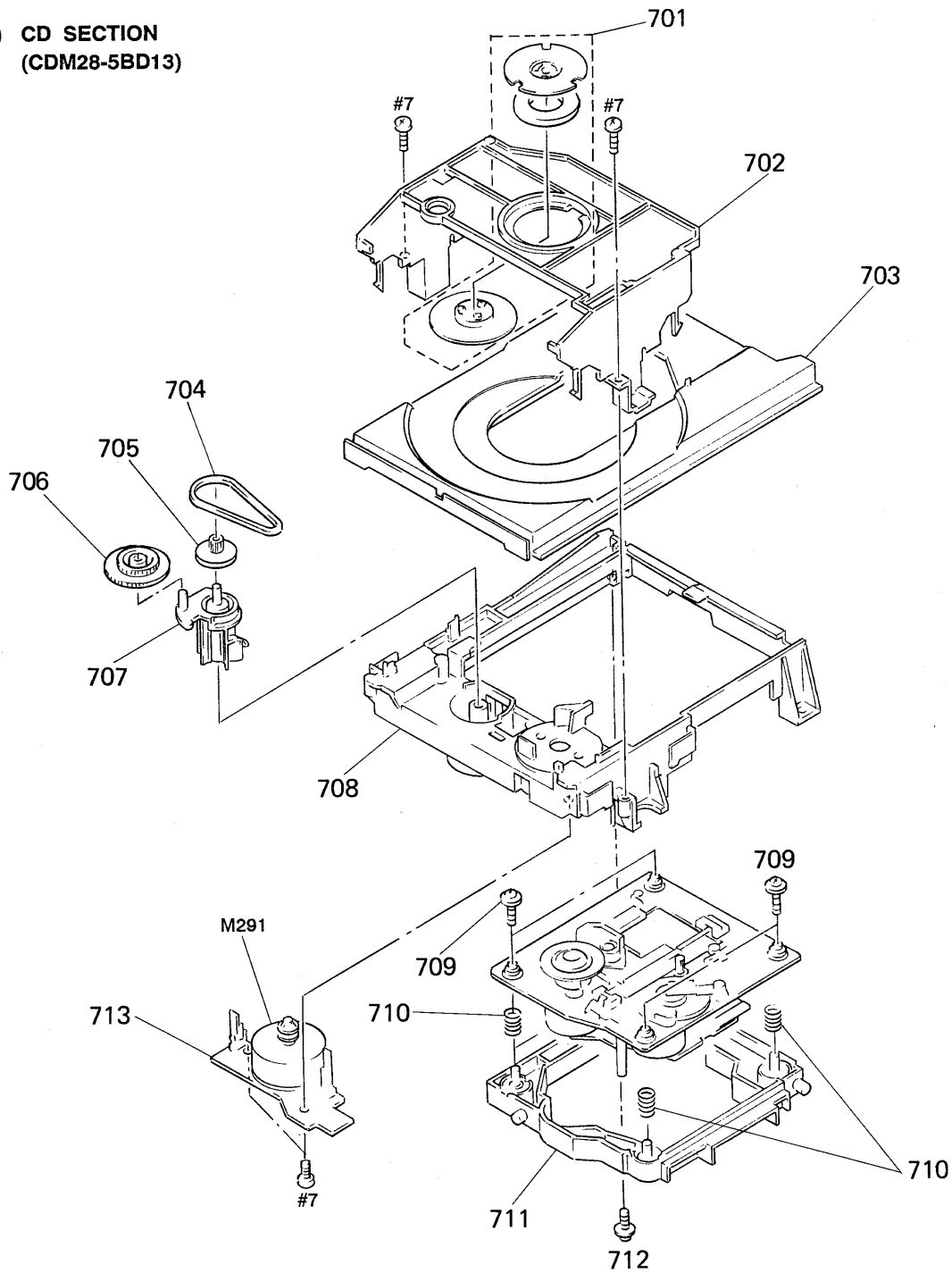

Ref. No.	Part No.	Description	Remark	Ref. No.	Part No.	Description	Remark
701	1-452-719-11	MAGNET ASSY		708	4-960-838-03	BASE (MD)	
702	4-960-835-01	HOLDER (M)		709	4-933-134-01	SCREW (+PTPWH M2. 6X6)	
703	4-960-836-01	TABLE, DISC		710	4-959-996-01	SPRING (932), COMPRESSION	
704	4-927-649-01	BELT		711	4-960-834-01	HOLDER (BU)	
705	4-960-841-01	PULLEY (S)		712	4-917-583-21	BRACKET, YOKE	
706	4-960-842-01	GEAR (P)		* 713	1-650-836-11	LOADING BOARD	
* 707	4-960-839-01	CAM		M291	A-4604-363-A	MOTOR (L) ASSY (LOADING)	

(5) BASE UNIT SECTION
(BU-5BD13)

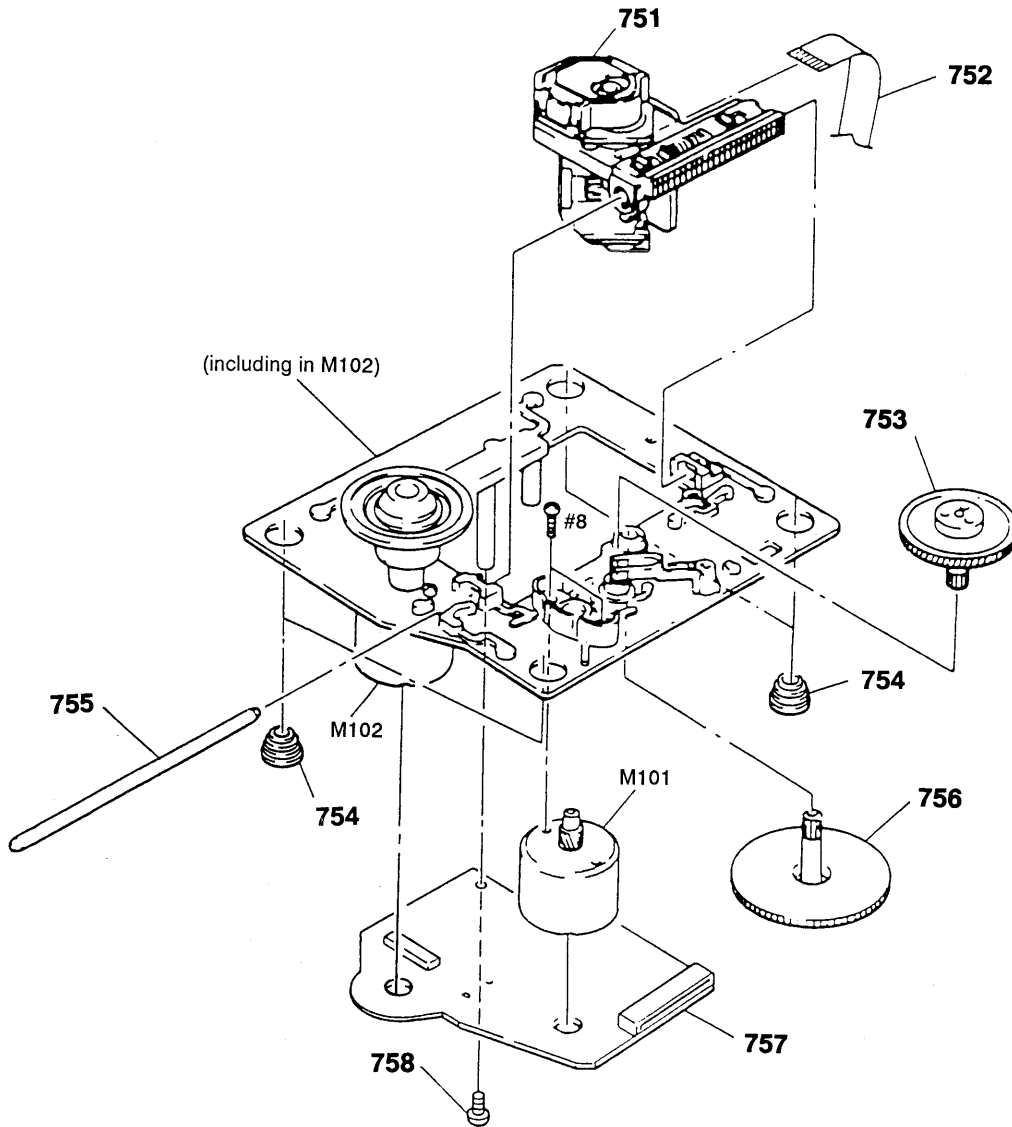

The components identified by mark Δ or dotted line with mark Δ are critical for safety. Replace only with part number specified.

Les composants identifiés par une marque Δ sont critiques pour la sécurité. Ne les remplacer que par une pièce portant le numéro spécifié.

Ref. No.	Part No.	Description	Remark	Ref. No.	Part No.	Description	Remark
Δ 751	8-848-144-11	DEVICE, OPTICAL KSS-240A		756	4-917-564-01	GEAR (P), FLATNESS	
752	1-575-001-11	WIRE, FLAT TYPE (12 CORE)		757	A-4649-890-A	BD BOARD, COMPLETE	
753	4-917-567-01	GEAR (M)		758	4-951-620-01	SCREW (2. 6X8), +BVTP	
754	4-951-940-01	INSULATOR (BU)		M101	X-4917-504-1	MOTOR ASSY (SLED)	
755	4-917-565-01	SHAFT, SLED		M102	X-4917-523-4	BASE (OUTSERT) ASSY (SPINDLE MOTOR)	

SECTION 6

ELECTRICAL PARTS LIST

AUDIO

NOTE:

- Due to standardization, replacements in the parts list may be different from the parts specified in the diagrams or the components used on the set.
- -XX and -X mean standardized parts, so they may have some difference from the original one.
- RESISTORS
All resistors are in ohms.
METAL: Metal-film resistor.
METAL OXIDE: Metal oxide-film resistor.
F: nonflammable

- Items marked "*" are not stocked since they are seldom required for routine service. Some delay should be anticipated when ordering these items.
- SEMICONDUCTORS
In each case, u: μ , for example:
uA.: μ A. uPA.: μ PA.
uPB.: μ PB. uPC.: μ PC. uPD.: μ PD.
- CAPACITORS
uF: μ F
- COILS
uH: μ H

The components identified by mark Δ or dotted line with mark Δ are critical for safety.
Replace only with part number specified.

Les composants identifiés par une marque Δ sont critiques pour la sécurité.
Ne les remplacer que par une pièce portant le numéro spécifié.

When indicating parts by reference number, please include the board.

Ref. No.	Part No.	Description	Remark	Ref. No.	Part No.	Description	Remark
*	A-2007-133-A	AUDIO BOARD, COMPLETE *****		*	CNP71	1-564-719-11 PIN, CONNECTOR (SMALL TYPE) 3P	
		< CAPACITOR >				< IC >	
C11	1-163-131-00	CERAMIC CHIP 390PF	5% 50V	IC31	8-759-249-21	IC uPC1330AGR	
C12	1-163-117-00	CERAMIC CHIP 100PF	5% 50V	IC32	8-759-106-02	IC uPC4570G2	
C13	1-136-153-00	FILM 0.01uF	5% 50V			< JUMPER RESISTOR >	
C14	1-126-177-11	ELECT 100uF	20% 10V	JW1	1-216-295-00	METAL CHIP 0 5% 1/10W	
C15	1-124-234-00	ELECT 22uF	20% 16V	JW2	1-216-295-00	METAL CHIP 0 5% 1/10W	
C16	1-136-434-11	FILM 120PF	5% 630V	JW11	1-216-296-91	CONDUCTOR, CHIP (3216)	
C17	1-164-080-11	CERAMIC 390PF	10% 50V	JW12	1-216-296-91	CONDUCTOR, CHIP (3216)	
C18	1-163-103-00	CERAMIC CHIP 27PF	5% 50V	JW13	1-216-296-91	CONDUCTOR, CHIP (3216)	
C21	1-163-131-00	CERAMIC CHIP 390PF	5% 50V	JW14	1-216-296-91	CONDUCTOR, CHIP (3216)	
C22	1-163-117-00	CERAMIC CHIP 100PF	5% 50V	JW15	1-216-296-91	CONDUCTOR, CHIP (3216)	
C23	1-136-153-00	FILM 0.01uF	5% 50V	JW16	1-216-296-91	CONDUCTOR, CHIP (3216)	
C24	1-126-177-11	ELECT 100uF	20% 10V	JW17	1-216-296-91	CONDUCTOR, CHIP (3216)	
C25	1-124-234-00	ELECT 22uF	20% 16V	JW18	1-216-296-91	CONDUCTOR, CHIP (3216)	
C26	1-136-434-11	FILM 120PF	5% 630V	JW19	1-216-296-91	CONDUCTOR, CHIP (3216)	
C27	1-164-080-11	CERAMIC 390PF	10% 50V	JW20	1-216-296-91	CONDUCTOR, CHIP (3216)	
C28	1-163-103-00	CERAMIC CHIP 27PF	5% 50V	JW21	1-216-296-91	CONDUCTOR, CHIP (3216)	
C31	1-124-234-00	ELECT 22uF	20% 16V	JW22	1-216-296-91	CONDUCTOR, CHIP (3216)	
C32	1-124-234-00	ELECT 22uF	20% 16V	JW23	1-216-296-91	CONDUCTOR, CHIP (3216)	
C33	1-124-234-00	ELECT 22uF	20% 16V	JW24	1-216-296-91	CONDUCTOR, CHIP (3216)	
C51	1-163-019-00	CERAMIC CHIP 0.0068uF	10% 50V	JW25	1-216-296-91	CONDUCTOR, CHIP (3216)	
C52	1-163-019-00	CERAMIC CHIP 0.0068uF	10% 50V	JW26	1-216-296-91	CONDUCTOR, CHIP (3216)	
C53	1-163-023-00	CERAMIC CHIP 0.015uF	5% 50V	JW27	1-216-296-91	CONDUCTOR, CHIP (3216)	
C54	1-136-601-11	FILM 0.01uF	5% 630V			< COIL >	
C56	1-164-505-11	CERAMIC CHIP 2.2uF	16V	L11	1-410-780-11	INDUCTOR 27mH	
C57	1-164-346-11	CERAMIC CHIP 1uF	16V	L21	1-410-780-11	INDUCTOR 27mH	
C58	1-164-232-11	CERAMIC CHIP 0.01uF	50V			< TRANSISTOR >	
C72	1-109-889-11	ELECT 1uF	20% 50V	Q51	8-729-111-29	TRANSISTOR 2SD1616A-K	
		< JACK >		Q52	8-729-111-29	TRANSISTOR 2SD1616A-K	
* CNJ31	1-580-782-11	CONNECTOR, BOARD TO BOARD		Q53	8-729-111-29	TRANSISTOR 2SD1616A-K	
* CNJ33	1-580-782-11	CONNECTOR, BOARD TO BOARD		Q71	8-729-216-22	TRANSISTOR 2SA1162-G	
CNJ72	1-764-902-11	CONNECTOR, FFC/FPC 4P				< RESISTOR >	
		< CONNECTOR >		R11	1-216-099-00	METAL CHIP 120K 5% 1/10W	
* CNP32	1-580-781-11	PIN, CONNECTOR (PC BOARD) 7P					

Ref. No.	Part No.	Description	Remark		
R12	1-216-033-00	METAL CHIP	220	5%	1/10W
R13	1-216-081-00	METAL CHIP	22K	5%	1/10W
R14	1-216-075-00	METAL CHIP	12K	5%	1/10W
R15	1-216-107-00	METAL CHIP	270K	5%	1/10W
R16	1-249-430-11	CARBON	12K	5%	1/4W
R21	1-216-099-00	METAL CHIP	120K	5%	1/10W
R22	1-216-033-00	METAL CHIP	220	5%	1/10W
R23	1-216-081-00	METAL CHIP	22K	5%	1/10W
R24	1-216-075-00	METAL CHIP	12K	5%	1/10W
R25	1-216-107-00	METAL CHIP	270K	5%	1/10W
R26	1-249-430-11	CARBON	12K	5%	1/4W
R31	1-216-033-00	METAL CHIP	220	5%	1/10W
R32	1-216-033-00	METAL CHIP	220	5%	1/10W
R33	1-216-073-00	METAL CHIP	10K	5%	1/10W
△R41	1-249-393-11	CARBON	10	5%	1/4W F
△R42	1-249-393-11	CARBON	10	5%	1/4W F
R51	1-216-689-11	METAL CHIP	39K	0.5%	1/10W
R52	1-216-689-11	METAL CHIP	39K	0.5%	1/10W
R53	1-216-073-00	METAL CHIP	10K	5%	1/10W
R54	1-216-309-00	METAL CHIP	5.6	5%	1/10W
R55	1-216-309-00	METAL CHIP	5.6	5%	1/10W
R56	1-216-298-00	METAL CHIP	2.2	5%	1/10W
R71	1-216-082-00	METAL GLAZE	24K	5%	1/10W
R72	1-216-081-00	METAL CHIP	22K	5%	1/10W
R73	1-216-089-91	METAL GLAZE	47K	5%	1/10W
R74	1-216-089-91	METAL GLAZE	47K	5%	1/10W
< VARIABLE RESISTOR >					
RV11	1-241-761-11	RES, ADJ, CARBON 1K (PB LEVEL L)			
RV12	1-238-551-11	RES, ADJ, CARBON 220K (PB LEVEL L)			
RV21	1-241-761-11	RES, ADJ, CARBON 1K (PB LEVEL R)			
RV22	1-238-551-11	RES, ADJ, CARBON 220K (PB LEVEL R)			
RV71	1-241-630-11	RES, ADJ, CARBON 10K (NORMAL SPEED)			
RV72	1-241-630-11	RES, ADJ, CARBON 10K (HIGH SPEED)			
< TRANSFORMER >					
T51	1-423-980-11	TRANSFORMER, BIAS OSCILLATION			

A-4649-890-A BD BOARD, COMPLETE					

< CAPACITOR >					
C101	1-163-005-11	CERAMIC CHIP	470PF	10%	50V
C102	1-163-038-00	CERAMIC CHIP	0.1uF		25V
C103	1-163-005-11	CERAMIC CHIP	470PF	10%	50V
C105	1-135-155-21	TANTALUM CHIP	4.7uF	10%	16V
C106	1-164-346-11	CERAMIC CHIP	1uF		16V

Ref. No.	Part No.	Description	Remark		
C107	1-164-505-11	CERAMIC CHIP	2.2uF		16V
C108	1-163-035-00	CERAMIC CHIP	0.047uF		50V
C109	1-163-011-11	CERAMIC CHIP	0.0015uF	10%	50V
C110	1-163-017-00	CERAMIC CHIP	0.0047uF	5%	50V
C111	1-163-251-11	CERAMIC CHIP	100PF	5%	50V
C112	1-163-038-00	CERAMIC CHIP	0.1uF		25V
C113	1-163-038-00	CERAMIC CHIP	0.1uF		25V
C123	1-164-232-11	CERAMIC CHIP	0.01uF		50V
C124	1-164-005-11	CERAMIC CHIP	0.47uF		25V
C131	1-163-038-00	CERAMIC CHIP	0.1uF		25V
C132	1-163-038-00	CERAMIC CHIP	0.1uF		25V
C133	1-163-038-00	CERAMIC CHIP	0.1uF		25V
C153	1-163-038-00	CERAMIC CHIP	0.1uF		25V
C159	1-163-019-00	CERAMIC CHIP	0.0068uF	10%	50V
C161	1-163-038-00	CERAMIC CHIP	0.1uF		25V
C177	1-163-038-00	CERAMIC CHIP	0.1uF		25V
C178	1-163-038-00	CERAMIC CHIP	0.1uF		25V
C179	1-163-038-00	CERAMIC CHIP	0.1uF		25V
C181	1-163-038-00	CERAMIC CHIP	0.1uF		25V
C182	1-163-038-00	CERAMIC CHIP	0.1uF		25V
C183	1-135-156-21	TANTALUM CHIP	6.8uF	10%	10V
C184	1-135-156-21	TANTALUM CHIP	6.8uF	10%	10V
C185	1-135-156-21	TANTALUM CHIP	6.8uF	10%	10V
C186	1-163-038-00	CERAMIC CHIP	0.1uF		25V
C187	1-163-038-00	CERAMIC CHIP	0.1uF		25V
C188	1-163-038-00	CERAMIC CHIP	0.1uF		25V
C191	1-163-091-00	CERAMIC CHIP	8PF		50V
C192	1-163-091-00	CERAMIC CHIP	8PF		50V
C193	1-163-125-00	CERAMIC CHIP	220PF	5%	50V
C194	1-163-125-00	CERAMIC CHIP	220PF	5%	50V
C195	1-163-038-00	CERAMIC CHIP	0.1uF		25V
C196	1-163-005-11	CERAMIC CHIP	470PF	10%	50V
C197	1-163-038-00	CERAMIC CHIP	0.1uF		25V
< CONNECTOR >					
CN101	1-691-199-21	CONNECTOR, FPC 26P			
CN102	1-565-771-11	CONNECTOR, FPC (1.0MM) (ZIF) 12P			
< IC >					
IC101	8-752-361-94	IC CXD2515Q			
IC102	8-759-176-09	IC BA6392FP			
IC103	8-752-367-61	IC CXD2565AM			
< COIL >					
L101	1-414-234-11	INDUCTOR, FERRITE BEAD			
L102	1-414-234-11	INDUCTOR, FERRITE BEAD			
L103	1-414-234-11	INDUCTOR, FERRITE BEAD			
L104	1-216-001-00	METAL CHIP	10	5%	1/10W
L105	1-216-295-00	METAL CHIP	0	5%	1/10W

Note:
The components identified by mark △ or dotted line with mark △ are critical for safety. Replace only with part number specified.

Note:
Les composants identifiés par une marque △ sont critiques pour la sécurité. Ne les remplacer que par une pièce portant le numéro spécifié.

BD **LEAF SW** **LOADING** **MAIN** **HP** **POWER**

Ref. No.	Part No.	Description	Remark
L106	1-414-234-11	INDUCTOR, FERRITE BEAD	
L107	1-216-295-00	METAL CHIP 0 5% 1/10W	
L108	1-216-295-00	METAL CHIP 0 5% 1/10W	
< RESISTOR >			
R101	1-216-077-00	METAL CHIP 15K 5% 1/10W	
R102	1-216-097-00	METAL CHIP 100K 5% 1/10W	
R103	1-216-077-00	METAL CHIP 15K 5% 1/10W	
R104	1-216-085-00	METAL CHIP 33K 5% 1/10W	
R105	1-216-065-00	METAL CHIP 4.7K 5% 1/10W	
R106	1-216-061-00	METAL CHIP 3.3K 5% 1/10W	
R107	1-216-061-00	METAL CHIP 3.3K 5% 1/10W	
R108	1-216-073-00	METAL CHIP 10K 5% 1/10W	
R109	1-216-121-91	METAL GLAZE 1M 5% 1/10W	
R110	1-216-025-00	METAL CHIP 100 5% 1/10W	
R112	1-216-049-00	METAL CHIP 1K 5% 1/10W	
R122	1-216-295-00	METAL CHIP 0 5% 1/10W	
R123	1-216-073-00	METAL CHIP 10K 5% 1/10W	
R124	1-216-097-00	METAL CHIP 100K 5% 1/10W	
R125	1-216-049-00	METAL CHIP 1K 5% 1/10W	
R126	1-216-049-00	METAL CHIP 1K 5% 1/10W	
R127	1-216-049-00	METAL CHIP 1K 5% 1/10W	
R131	1-216-037-00	METAL CHIP 330 5% 1/10W	
R158	1-216-111-91	METAL GLAZE 390K 5% 1/10W	
R159	1-216-101-00	METAL CHIP 150K 5% 1/10W	
R181	1-216-053-00	METAL CHIP 1.5K 5% 1/10W	
R182	1-216-080-00	METAL CHIP 20K 5% 1/10W	
R183	1-216-080-00	METAL CHIP 20K 5% 1/10W	
R184	1-216-080-00	METAL CHIP 20K 5% 1/10W	
R185	1-216-080-00	METAL CHIP 20K 5% 1/10W	
R187	1-216-035-00	METAL CHIP 270 5% 1/10W	
R188	1-216-121-91	METAL GLAZE 1M 5% 1/10W	
R189	1-414-234-11	INDUCTOR, FERRITE BEAD	

< SWITCH >

S101 1-572-085-11 SWITCH, LEAF (LIMIT)

< VIBRATOR >

X101 1-579-904-11 VIBRATOR, CRYSTAL (33.8MHz)

* 1-638-020-11 LEAF SW BOARD

< CONNECTOR >

* CNP81 1-568-850-11 SOCKET, CONNECTOR 7P

< IC >

IC81 8-749-924-10 IC PHONT REFLECTOR NJL5165K-B(H1)

< RESISTOR >

R81	1-249-414-11	CARBON 560 5% 1/4W
R82	1-247-818-11	CARBON 300 5% 1/4W
R83	1-247-834-11	CARBON 1.3K 5% 1/4W
R84	1-249-417-11	CARBON 1K 5% 1/4W
R85	1-249-408-11	CARBON 180 5% 1/4W

< SWITCH >

S81	1-571-958-11	SWITCH, PUSH (1 KEY) (STOP)
S82	1-571-281-21	SWITCH, LEAF (CrO2)
S83	1-571-281-21	SWITCH, LEAF (METAL)
S84	1-571-281-21	SWITCH, LEAF (REC A)
S85	1-571-281-21	SWITCH, LEAF (REC B)

S86 1-571-281-21 SWITCH, LEAF (HALF)

* 1-650-836-11 LOADING BOARD

< CONNECTOR >

* CN291 1-568-943-11 PIN, CONNECTOR 5P

< SWITCH >

S291	1-572-086-11	SWITCH, LEAF (LOAD OUT)
S292	1-572-086-11	SWITCH, LEAF (LOAD IN)

* A-2007-413-A MAIN BOARD, COMPLETE (Canadian)
* A-2007-415-A MAIN BOARD, COMPLETE (AEP, German)

HP BOARD

POWER BOARD

4-902-345-01 HEAT SINK
7-685-871-01 SCREW +BVTT 3X6 (S)

< CAPACITOR >

C101	1-136-157-00	FILM 0.022uF 5% 50V
C102	1-137-457-11	FILM 0.0027uF 5% 50V
C104	1-124-907-11	ELECT 10uF 20% 50V
C105	1-124-907-11	ELECT 10uF 20% 50V
C106	1-124-907-11	ELECT 10uF 20% 50V
C107	1-136-165-00	FILM 0.1uF 5% 50V

MAIN	HP	POWER
------	----	-------

Ref. No.	Part No.	Description	Remark		
C108	1-136-163-00	FILM	0.068uF	5%	50V
C111	1-126-962-11	ELECT	3.3uF	20%	50V
C112	1-124-902-00	ELECT	0.47uF	20%	50V
C113	1-126-963-11	ELECT	4.7uF	20%	50V
C115	1-124-925-11	ELECT	2.2uF	20%	100V
C116	1-161-494-00	CERAMIC	0.022uF		25V
C131	1-124-902-00	ELECT	0.47uF	20%	50V
C134	1-162-291-31	CERAMIC	560PF	10%	50V
C161	1-162-305-11	CERAMIC	0.0068uF	30%	16V
C171	1-162-280-31	CERAMIC	82PF	10%	50V
C172	1-162-280-31	CERAMIC	82PF	10%	50V
C173	1-130-480-00	MYLAR	0.0056uF	5%	50V
C174	1-130-471-00	MYLAR	0.001uF	5%	50V
C175	1-124-477-11	ELECT	47uF	20%	25V
C201	1-136-157-00	FILM	0.022uF	5%	50V
C202	1-137-457-11	FILM	0.0027uF	5%	50V
C204	1-124-907-11	ELECT	10uF	20%	50V
C205	1-124-907-11	ELECT	10uF	20%	50V
C206	1-124-907-11	ELECT	10uF	20%	50V
C207	1-136-165-00	FILM	0.1uF	5%	50V
C208	1-136-163-00	FILM	0.068uF	5%	50V
C211	1-126-962-11	ELECT	3.3uF	20%	50V
C212	1-124-902-00	ELECT	0.47uF	20%	50V
C213	1-126-963-11	ELECT	4.7uF	20%	50V
C215	1-124-925-11	ELECT	2.2uF	20%	100V
C216	1-161-494-00	CERAMIC	0.022uF		25V
C231	1-124-902-00	ELECT	0.47uF	20%	50V
C234	1-162-291-31	CERAMIC	560PF	10%	50V
C261	1-162-305-11	CERAMIC	0.0068uF	30%	16V
C271	1-162-280-31	CERAMIC	82PF	10%	50V
C272	1-162-280-31	CERAMIC	82PF	10%	50V
C273	1-130-480-00	MYLAR	0.0056uF	5%	50V
C274	1-130-471-00	MYLAR	0.001uF	5%	50V
C275	1-124-477-11	ELECT	47uF	20%	25V
C501	1-124-907-11	ELECT	10uF	20%	50V
C502	1-104-666-11	ELECT	220uF	20%	10V
C503	1-124-477-11	ELECT	47uF	20%	25V
C504	1-164-159-11	CERAMIC	0.1uF		50V
C511	1-162-211-31	CERAMIC	33PF	5%	50V
C512	1-162-217-31	CERAMIC	56PF	5%	50V
C513	1-124-925-11	ELECT	2.2uF	20%	100V
C514	1-161-494-00	CERAMIC	0.022uF		25V
C515	1-124-925-11	ELECT	2.2uF	20%	100V
C517	1-126-952-11	ELECT	1000uF	20%	16V
C524	1-124-903-11	ELECT	1uF	20%	50V
C531	1-126-916-11	ELECT	1000uF	20%	6.3V
C541	1-136-175-00	FILM	0.68uF	5%	50V
C542	1-136-168-00	FILM	0.18uF	5%	50V
C543	1-136-153-00	FILM	0.01uF	5%	50V

Ref. No.	Part No.	Description	Remark		
C544	1-126-962-11	ELECT	3.3uF	20%	50V
C545	1-124-907-11	ELECT	10uF	20%	50V
C701	1-126-943-11	ELECT	2200uF	20%	25V
C702	1-161-494-00	CERAMIC	0.022uF		25V
C703	1-104-666-11	ELECT	220uF	20%	10V
C704	1-164-159-11	CERAMIC	0.1uF		50V
C705	1-124-907-11	ELECT	10uF	20%	50V
C706	1-126-941-11	ELECT	470uF	20%	6.3V
C707	1-126-768-11	ELECT	2200uF	20%	16V
C708	1-126-768-11	ELECT	2200uF	20%	16V
C709	1-124-477-11	ELECT	47uF	20%	25V
C710	1-124-473-11	ELECT	1000uF	20%	10V
C711	1-124-473-11	ELECT	1000uF	20%	10V
C712	1-124-122-11	ELECT	100uF	20%	50V
C713	1-124-477-11	ELECT	47uF	20%	25V
C714	1-161-494-00	CERAMIC	0.022uF		25V
C715	1-124-903-11	ELECT	1uF	20%	50V
C719	1-126-963-11	ELECT	4.7uF	20%	50V
C720	1-126-963-11	ELECT	4.7uF	20%	50V
C721	1-126-941-11	ELECT	470uF	20%	6.3V
C801	1-124-443-00	ELECT	100uF	20%	10V
C802	1-161-494-00	CERAMIC	0.022uF		25V
C803	1-126-963-11	ELECT	4.7uF	20%	50V
C804	1-124-907-11	ELECT	10uF	20%	50V
C805	1-162-288-31	CERAMIC	330PF	10%	50V
C806	1-164-159-11	CERAMIC	0.1uF		50V
C807	1-162-306-11	CERAMIC	0.01uF	30%	16V
C808	1-161-494-00	CERAMIC	0.022uF		25V
C809	1-164-159-11	CERAMIC	0.1uF		50V
C810	1-164-159-11	CERAMIC	0.1uF		50V
C811	1-161-494-00	CERAMIC	0.022uF		25V
C812	1-161-494-00	CERAMIC	0.022uF		25V
C813	1-161-494-00	CERAMIC	0.022uF		25V
C814	1-161-494-00	CERAMIC	0.022uF		25V
C815	1-161-494-00	CERAMIC	0.022uF		25V

< CONNECTOR >

- * CN801 1-568-826-11 SOCKET, CONNECTOR 7P
- * CN804 1-568-830-11 SOCKET, CONNECTOR 11P
- * CN805 1-568-845-11 SOCKET, CONNECTOR 31P

< CONNECTOR >

- * CNP501 1-568-954-11 PIN, CONNECTOR 5P
- * CNP502 1-568-954-11 PIN, CONNECTOR 5P
- * CNP503 1-691-916-11 CONNECTOR, BOARD TO BOARD
- * CNP504 1-691-916-11 CONNECTOR, BOARD TO BOARD
- CNP701 1-766-272-11 PIN, CONNECTOR (PC BOARD) 10P
- * CNP702 1-580-230-31 PIN, CONNECTOR (PC BOARD) 2P
- CNP703 1-766-275-11 PIN, CONNECTOR (PC BOARD) 2P

MAIN HP POWER

Ref. No.	Part No.	Description	Remark	Ref. No.	Part No.	Description	Remark
< DIODE >							
D131	8-719-987-63	DIODE 1N4148M		IC509	8-759-000-48	IC MC14052BCP	
D132	8-719-987-63	DIODE 1N4148M		IC510	8-759-634-51	IC M5218AP	
D141	8-719-987-63	DIODE 1N4148M		IC511	8-759-634-51	IC M5218AP	
D142	8-719-987-63	DIODE 1N4148M		IC601	8-759-634-51	IC M5218AP	
D143	8-719-987-63	DIODE 1N4148M		IC602	8-759-634-51	IC M5218AP	
D231	8-719-987-63	DIODE 1N4148M		IC701	8-759-634-51	IC M5218AP	
D232	8-719-987-63	DIODE 1N4148M		IC702	8-759-071-48	IC TA7807S	
D241	8-719-987-63	DIODE 1N4148M		IC703	8-759-061-65	IC LA5602	
D242	8-719-987-63	DIODE 1N4148M		IC801	8-759-357-17	IC uPD78044AGF-133-3B9	
D243	8-719-987-63	DIODE 1N4148M		IC802	8-759-165-82	IC PST600E-T	
D501	8-719-987-63	DIODE 1N4148M		IC803	8-759-000-48	IC MC14052BCP	
D502	8-719-987-63	DIODE 1N4148M		IC805	8-759-803-42	IC LA6500-FA	
D511	8-719-987-63	DIODE 1N4148M		IC806	8-759-822-09	IC LB1641	
D541	8-719-987-63	DIODE 1N4148M		< JACK >			
D701	8-719-024-99	DIODE 11ES2-NTA2B		J501	1-565-320-81	JACK, PIN 6P(CD LINE OUT, TC LINE IN/OUT)	
D702	8-719-024-99	DIODE 11ES2-NTA2B		J502	1-507-796-71	JACK (PHONES)	
D703	8-719-024-99	DIODE 11ES2-NTA2B		< COIL >			
D704	8-719-024-99	DIODE 11ES2-NTA2B		L801	1-410-322-11	INDUCTOR 3.3uH	
D705	8-719-024-99	DIODE 11ES2-NTA2B		L802	1-410-322-11	INDUCTOR 3.3uH	
D706	8-719-024-99	DIODE 11ES2-NTA2B		< FILTER >			
D707	8-719-024-99	DIODE 11ES2-NTA2B		LPF101	1-239-355-11	FILTER, LOW PASS	
D708	8-719-024-99	DIODE 11ES2-NTA2B		LPF201	1-239-355-11	FILTER, LOW PASS	
D709	8-719-987-63	DIODE 1N4148M		< TRANSISTOR >			
D710	8-719-987-63	DIODE 1N4148M		Q101	8-729-900-89	TRANSISTOR DTC144ES	
D711	8-719-987-63	DIODE 1N4148M		Q102	8-729-900-80	TRANSISTOR DTC114ES	
D712	8-719-000-60	DIODE UZL-6M2		Q131	8-729-922-37	TRANSISTOR 2SD2144S	
D713	8-719-933-33	DIODE HZS6A1L		Q132	8-729-922-37	TRANSISTOR 2SD2144S	
D714	8-719-933-33	DIODE HZS6A1L		Q133	8-729-900-61	TRANSISTOR DTA114ES	
D715	8-719-024-99	DIODE 11ES2-NTA2B		Q141	8-729-900-74	TRANSISTOR DTC143TS	
D716	8-719-987-63	DIODE 1N4148M		Q142	8-729-900-74	TRANSISTOR DTC143TS	
D717	8-719-987-63	DIODE 1N4148M		Q201	8-729-900-89	TRANSISTOR DTC144ES	
D718	8-719-933-50	DIODE HZS7C2L		Q202	8-729-900-80	TRANSISTOR DTC114ES	
D719	8-719-933-33	DIODE HZS6A1L		Q231	8-729-922-37	TRANSISTOR 2SD2144S	
D720	8-719-987-63	DIODE 1N4148M		Q232	8-729-922-37	TRANSISTOR 2SD2144S	
D721	8-719-933-33	DIODE HZS6A1L		Q233	8-729-900-61	TRANSISTOR DTA114ES	
D801	8-719-010-29	DIODE UZ-4.3BSB		Q241	8-729-900-74	TRANSISTOR DTC143TS	
D802	8-719-933-33	DIODE HZS6A1L		Q242	8-729-900-74	TRANSISTOR DTC143TS	
< IC >				Q501	8-729-900-89	TRANSISTOR DTC144ES	
IC501	8-752-060-46	IC CXA1561S		Q502	8-729-900-80	TRANSISTOR DTC114ES	
IC502	8-752-055-61	IC CXA1578P		Q503	8-729-900-80	TRANSISTOR DTC114ES	
IC503	8-759-635-26	IC M5283P		Q505	8-729-900-65	TRANSISTOR DTA144ES	
IC504	8-759-000-49	IC MC14066BCP		Q506	8-729-900-65	TRANSISTOR DTA144ES	
IC505	8-759-000-49	IC MC14066BCP					
IC506	8-759-634-51	IC M5218AP					
IC507	8-759-634-51	IC M5218AP					
IC508	8-759-634-51	IC M5218AP					

MAIN**HP****POWER**

Ref. No.	Part No.	Description	Remark
Q507	8-729-900-80	TRANSISTOR DTC114ES	
Q511	8-729-119-76	TRANSISTOR 2SA1175-HFE	
Q512	8-729-900-80	TRANSISTOR DTC114ES	
Q531	8-729-119-76	TRANSISTOR 2SA1175-HFE	
Q551	8-729-900-89	TRANSISTOR DTC144ES	
Q701	8-729-141-83	TRANSISTOR 2SB1094-LK	
Q702	8-729-119-78	TRANSISTOR 2SC403SP-51	
Q703	8-729-900-74	TRANSISTOR DTC143TS	
Q704	8-729-900-74	TRANSISTOR DTC143TS	
Q705	8-729-141-83	TRANSISTOR 2SB1094-LK	
Q706	8-729-209-15	TRANSISTOR 2SD2012	
Q707	8-729-119-76	TRANSISTOR 2SA1175-HFE	
Q708	8-729-140-04	TRANSISTOR 2SB1116A-L	
Q709	8-729-900-65	TRANSISTOR DTA144ES	
Q801	8-729-119-76	TRANSISTOR 2SA1175-HFE	
Q802	8-729-801-93	TRANSISTOR 2SD1387	
Q803	8-729-900-80	TRANSISTOR DTC114ES	
< RESISTOR >			
R100	1-249-433-11	CARBON 22K 5% 1/4W	
R101	1-249-421-11	CARBON 2.2K 5% 1/4W	
R102	1-249-423-11	CARBON 3.3K 5% 1/4W	
R103	1-249-423-11	CARBON 3.3K 5% 1/4W	
R104	1-249-424-11	CARBON 3.9K 5% 1/4W	
R105	1-247-887-00	CARBON 220K 5% 1/4W	
R106	1-249-417-11	CARBON 1K 5% 1/4W	
R107	1-249-429-11	CARBON 10K 5% 1/4W	
R111	1-249-429-11	CARBON 10K 5% 1/4W	
R112	1-249-423-11	CARBON 3.3K 5% 1/4W	
R113	1-249-423-11	CARBON 3.3K 5% 1/4W	
R115	1-249-441-11	CARBON 100K 5% 1/4W	
R116	1-247-887-00	CARBON 220K 5% 1/4W	
R131	1-249-417-11	CARBON 1K 5% 1/4W	
R132	1-249-421-11	CARBON 2.2K 5% 1/4W	
R133	1-249-437-11	CARBON 47K 5% 1/4W	
R134	1-249-421-11	CARBON 2.2K 5% 1/4W	
R135	1-249-417-11	CARBON 1K 5% 1/4W	
R136	1-249-421-11	CARBON 2.2K 5% 1/4W	
R137	1-249-433-11	CARBON 22K 5% 1/4W	
R138	1-249-417-11	CARBON 1K 5% 1/4W	
R139	1-247-887-00	CARBON 220K 5% 1/4W	
R141	1-249-435-11	CARBON 33K 5% 1/4W	
R142	1-249-441-11	CARBON 100K 5% 1/4W	
R161	1-249-441-11	CARBON 100K 5% 1/4W	
R162	1-247-868-11	CARBON 36K 5% 1/4W	
R163	1-249-421-11	CARBON 2.2K 5% 1/4W	
R164	1-247-854-11	CARBON 9.1K 5% 1/4W	
R165	1-249-409-11	CARBON 220 5% 1/4W	
R171	1-247-852-11	CARBON 7.5K 5% 1/4W	

Ref. No.	Part No.	Description	Remark
R172	1-247-852-11	CARBON 7.5K 5% 1/4W	
R173	1-249-434-11	CARBON 27K 5% 1/4W	
R174	1-249-434-11	CARBON 27K 5% 1/4W	
R175	1-249-419-11	CARBON 1.5K 5% 1/4W	
R176	1-249-419-11	CARBON 1.5K 5% 1/4W	
R177	1-249-441-11	CARBON 100K 5% 1/4W	
R200	1-249-433-11	CARBON 22K 5% 1/4W	
R201	1-249-421-11	CARBON 2.2K 5% 1/4W	
R202	1-249-423-11	CARBON 3.3K 5% 1/4W	
R203	1-249-423-11	CARBON 3.3K 5% 1/4W	
R204	1-249-424-11	CARBON 3.9K 5% 1/4W	
R205	1-247-887-00	CARBON 220K 5% 1/4W	
R206	1-249-417-11	CARBON 1K 5% 1/4W	
R207	1-249-429-11	CARBON 10K 5% 1/4W	
R211	1-249-429-11	CARBON 10K 5% 1/4W	
R212	1-249-423-11	CARBON 3.3K 5% 1/4W	
R213	1-249-423-11	CARBON 3.3K 5% 1/4W	
R215	1-249-441-11	CARBON 100K 5% 1/4W	
R216	1-247-887-00	CARBON 220K 5% 1/4W	
R231	1-249-417-11	CARBON 1K 5% 1/4W	
R232	1-249-421-11	CARBON 2.2K 5% 1/4W	
R233	1-249-437-11	CARBON 47K 5% 1/4W	
R234	1-249-421-11	CARBON 2.2K 5% 1/4W	
R235	1-249-417-11	CARBON 1K 5% 1/4W	
R236	1-249-421-11	CARBON 2.2K 5% 1/4W	
R237	1-249-433-11	CARBON 22K 5% 1/4W	
R238	1-249-417-11	CARBON 1K 5% 1/4W	
R239	1-247-887-00	CARBON 220K 5% 1/4W	
R241	1-249-435-11	CARBON 33K 5% 1/4W	
R242	1-249-441-11	CARBON 100K 5% 1/4W	
R261	1-249-441-11	CARBON 100K 5% 1/4W	
R262	1-247-868-11	CARBON 36K 5% 1/4W	
R263	1-249-421-11	CARBON 2.2K 5% 1/4W	
R264	1-247-854-11	CARBON 9.1K 5% 1/4W	
R265	1-249-409-11	CARBON 220 5% 1/4W	
R271	1-247-852-11	CARBON 7.5K 5% 1/4W	
R272	1-247-852-11	CARBON 7.5K 5% 1/4W	
R273	1-249-434-11	CARBON 27K 5% 1/4W	
R274	1-249-434-11	CARBON 27K 5% 1/4W	
R275	1-249-419-11	CARBON 1.5K 5% 1/4W	
R276	1-249-419-11	CARBON 1.5K 5% 1/4W	
R277	1-249-441-11	CARBON 100K 5% 1/4W	
R501	1-215-452-00	METAL 20K 1% 1/4W	
R502	1-215-455-00	METAL 27K 1% 1/4W	
R503	1-249-433-11	CARBON 22K 5% 1/4W	
R504	1-249-429-11	CARBON 10K 5% 1/4W	
R505	1-249-437-11	CARBON 47K 5% 1/4W	
R506	1-249-429-11	CARBON 10K 5% 1/4W	
R507	1-249-435-11	CARBON 33K 5% 1/4W	

MAIN

HP

POWER

Ref. No.	Part No.	Description	Remark
R508	1-249-435-11	CARBON	33K 5% 1/4W
R509	1-249-435-11	CARBON	33K 5% 1/4W
R510	1-249-433-11	CARBON	22K 5% 1/4W
R511	1-249-413-11	CARBON	470 5% 1/4W
R512	1-249-429-11	CARBON	10K 5% 1/4W
R513	1-247-883-00	CARBON	150K 5% 1/4W
R514	1-249-427-11	CARBON	6.8K 5% 1/4W
R515	1-249-423-11	CARBON	3.3K 5% 1/4W
R516	1-249-428-11	CARBON	8.2K 5% 1/4W
R517	1-249-441-11	CARBON	100K 5% 1/4W
R518	1-249-429-11	CARBON	10K 5% 1/4W
R519	1-249-417-11	CARBON	1K 5% 1/4W
R520	1-249-432-11	CARBON	18K 5% 1/4W
R521	1-249-436-11	CARBON	39K 5% 1/4W
R522	1-249-441-11	CARBON	100K 5% 1/4W
R524	1-249-428-11	CARBON	8.2K 5% 1/4W
R525	1-249-421-11	CARBON	2.2K 5% 1/4W
R527	1-249-435-11	CARBON	33K 5% 1/4W
R528	1-247-807-31	CARBON	100 5% 1/4W
R531	1-249-437-11	CARBON	47K 5% 1/4W
R532	1-249-437-11	CARBON	47K 5% 1/4W
R533	1-249-429-11	CARBON	10K 5% 1/4W
R541	1-249-437-11	CARBON	47K 5% 1/4W
R542	1-249-437-11	CARBON	47K 5% 1/4W
R543	1-249-437-11	CARBON	47K 5% 1/4W
R544	1-247-874-11	CARBON	62K 5% 1/4W
R545	1-249-410-11	CARBON	270 5% 1/4W
R546	1-249-421-11	CARBON	2.2K 5% 1/4W
R551	1-249-433-11	CARBON	22K 5% 1/4W
R552	1-249-429-11	CARBON	10K 5% 1/4W
R553	1-249-429-11	CARBON	10K 5% 1/4W
R701	1-249-421-11	CARBON	2.2K 5% 1/4W
R702	1-249-425-11	CARBON	4.7K 5% 1/4W
R703	1-249-425-11	CARBON	4.7K 5% 1/4W
R704	1-249-419-11	CARBON	1.5K 5% 1/4W
R705	1-249-418-11	CARBON	1.2K 5% 1/4W
R706	1-249-427-11	CARBON	6.8K 5% 1/4W
R707	1-249-419-11	CARBON	1.5K 5% 1/4W
R708	1-249-429-11	CARBON	10K 5% 1/4W
R709	1-249-419-11	CARBON	1.5K 5% 1/4W
R710	1-249-427-11	CARBON	6.8K 5% 1/4W
R711	1-249-427-11	CARBON	6.8K 5% 1/4W
R712	1-249-417-11	CARBON	1K 5% 1/4W
R713	1-249-409-11	CARBON	220 5% 1/4W
R714	1-249-425-11	CARBON	4.7K 5% 1/4W
R715	1-249-427-11	CARBON	6.8K 5% 1/4W
R716	1-247-866-11	CARBON	30K 5% 1/4W
R717	1-249-429-11	CARBON	10K 5% 1/4W

Ref. No.	Part No.	Description	Remark
R718	1-249-437-11	CARBON	47K 5% 1/4W
R719	1-249-429-11	CARBON	10K 5% 1/4W
R720	1-249-417-11	CARBON	1K 5% 1/4W
R721	1-249-414-11	CARBON	560 5% 1/4W
△R722	1-219-137-11	FUSIBLE	0.33 10% 1/4W F
△R723	1-217-371-00	FUSIBLE	0.47 10% 1/4W F
△R724	1-219-139-11	FUSIBLE	0.68 10% 1/4W F
R801	1-249-441-11	CARBON	100K 5% 1/4W
R802	1-249-417-11	CARBON	1K 5% 1/4W
R803	1-247-807-31	CARBON	100 5% 1/4W
R804	1-247-807-31	CARBON	100 5% 1/4W
R805	1-247-807-31	CARBON	100 5% 1/4W
R806	1-247-807-31	CARBON	100 5% 1/4W
R807	1-249-422-11	CARBON	2.7K 5% 1/4W
R808	1-249-422-11	CARBON	2.7K 5% 1/4W
R809	1-249-422-11	CARBON	2.7K 5% 1/4W
R810	1-249-429-11	CARBON	10K 5% 1/4W
R811	1-247-862-11	CARBON	20K 5% 1/4W
R812	1-249-430-11	CARBON	12K 5% 1/4W
R813	1-249-433-11	CARBON	22K 5% 1/4W
R814	1-249-433-11	CARBON	22K 5% 1/4W
R815	1-249-433-11	CARBON	22K 5% 1/4W
R816	1-247-807-31	CARBON	100 5% 1/4W
R817	1-249-419-11	CARBON	1.5K 5% 1/4W
R818	1-249-429-11	CARBON	10K 5% 1/4W
R819	1-249-434-11	CARBON	27K 5% 1/4W
R820	1-249-421-11	CARBON	2.2K 5% 1/4W
R821	1-249-421-11	CARBON	2.2K 5% 1/4W
R822	1-249-421-11	CARBON	2.2K 5% 1/4W
R823	1-249-428-11	CARBON	8.2K 5% 1/4W
R824	1-249-418-11	CARBON	1.2K 5% 1/4W
R825	1-249-417-11	CARBON	1K 5% 1/4W
R826	1-249-417-11	CARBON	1K 5% 1/4W
R827	1-249-417-11	CARBON	1K 5% 1/4W
R828	1-249-417-11	CARBON	1K 5% 1/4W
R829	1-249-417-11	CARBON	1K 5% 1/4W
R830	1-249-417-11	CARBON	1K 5% 1/4W
R831	1-249-417-11	CARBON	1K 5% 1/4W
R833	1-249-418-11	CARBON	1.2K 5% 1/4W
R834	1-249-428-11	CARBON	8.2K 5% 1/4W
R835	1-249-441-11	CARBON	100K 5% 1/4W
R836	1-249-417-11	CARBON	1K 5% 1/4W
R837	1-249-429-11	CARBON	10K 5% 1/4W
< VARIABLE RESISTOR >			
RV111	1-241-630-11	RES, ADJ, CARBON 10K	
RV211	1-241-630-11	RES, ADJ, CARBON 10K	
RV501	1-223-864-11	RES, VAR, CARBON 1K/1K (LEVEL)	

Note:
The components identified by mark △ or dotted line with mark △ are critical for safety. Replace only with part number specified.

Note:
Les composants identifiés par une marque △ sont critiques pour la sécurité. Ne les remplacer que par une pièce portant le numéro spécifié.

MAIN

HP

POWER

PANEL

Ref. No.	Part No.	Description	Remark
		< TEST PIN >	
* TP801	1-560-060-00	PIN, CONNECTOR 2P	
		< VIBRATOR >	
X801	1-577-358-21	VIBRATOR, CERAMIC (4MHz)	

* A-2007-414-A	PANEL BOARD, COMPLETE		

	3-923-303-01	HOLDER (FL TUBE)	
		< CAPACITOR >	
C901	1-161-494-00	CERAMIC 0.022uF	25V
C902	1-161-494-00	CERAMIC 0.022uF	25V
C903	1-161-494-00	CERAMIC 0.022uF	25V
C904	1-161-494-00	CERAMIC 0.022uF	25V
		< CONNECTOR >	
* CN901	1-568-873-11	SOCKET, CONNECTOR 31P	
* CN902	1-568-854-11	SOCKET, CONNECTOR 11P	
		< DIODE >	
D901	8-719-313-48	DIODE SEL6210S-TH12 (AUTO)	
		< FILTER >	
FL901	1-517-421-11	INDICATOR TUBE, FLUORESCENT	
		< IC >	
IC901	8-741-810-59	IC SBX1810-59	
		< RESISTOR >	
R901	1-249-429-11	CARBON 10K 5% 1/4W	
R902	1-249-429-11	CARBON 10K 5% 1/4W	
R903	1-249-429-11	CARBON 10K 5% 1/4W	
R904	1-249-429-11	CARBON 10K 5% 1/4W	
R905	1-249-418-11	CARBON 1.2K 5% 1/4W	
R906	1-249-420-11	CARBON 1.8K 5% 1/4W	
R907	1-249-422-11	CARBON 2.7K 5% 1/4W	
R908	1-249-424-11	CARBON 3.9K 5% 1/4W	
R909	1-249-427-11	CARBON 6.8K 5% 1/4W	
R910	1-249-431-11	CARBON 15K 5% 1/4W	
R911	1-249-437-11	CARBON 47K 5% 1/4W	
R912	1-249-418-11	CARBON 1.2K 5% 1/4W	
R913	1-249-420-11	CARBON 1.8K 5% 1/4W	
R914	1-249-422-11	CARBON 2.7K 5% 1/4W	
R915	1-249-424-11	CARBON 3.9K 5% 1/4W	

Ref. No.	Part No.	Description	Remark
R916	1-249-427-11	CARBON 6.8K 5% 1/4W	
R917	1-249-431-11	CARBON 15K 5% 1/4W	
R918	1-249-437-11	CARBON 47K 5% 1/4W	
R919	1-249-418-11	CARBON 1.2K 5% 1/4W	
R920	1-249-420-11	CARBON 1.8K 5% 1/4W	
R921	1-249-422-11	CARBON 2.7K 5% 1/4W	
R922	1-249-424-11	CARBON 3.9K 5% 1/4W	
R923	1-249-427-11	CARBON 6.8K 5% 1/4W	
R924	1-249-431-11	CARBON 15K 5% 1/4W	
R926	1-249-418-11	CARBON 1.2K 5% 1/4W	
R927	1-249-420-11	CARBON 1.8K 5% 1/4W	
R928	1-249-422-11	CARBON 2.7K 5% 1/4W	
R929	1-249-424-11	CARBON 3.9K 5% 1/4W	
R930	1-249-427-11	CARBON 6.8K 5% 1/4W	
R933	1-249-413-11	CARBON 470 5% 1/4W	
R934	1-249-417-11	CARBON 1K 5% 1/4W	
R935	1-247-807-31	CARBON 100 5% 1/4W	
		< VARIABLE RESISTOR >	
RV901	1-241-797-11	RES, VAR, CARBON 20K (REC LEVEL)	
		< SWITCH >	
S701	1-692-409-11	SWITCH, PUSH (1 KEY) (POWER)	
S901	1-554-303-21	SWITCH, TACTILE (■)	
S902	1-554-303-21	SWITCH, TACTILE (◀(AMS))	
S903	1-554-303-21	SWITCH, TACTILE ((AMS)▶▶)	
S904	1-554-303-21	SWITCH, TACTILE (●REC)	
S905	1-554-303-21	SWITCH, TACTILE (ARL)	
S906	1-554-303-21	SWITCH, TACTILE (FADER)	
S907	1-554-303-21	SWITCH, TACTILE (▷)	
S908	1-554-303-21	SWITCH, TACTILE (<)	
S909	1-554-303-21	SWITCH, TACTILE (■)	
S910	1-554-303-21	SWITCH, TACTILE (●REC MUTE)	
S911	1-554-303-21	SWITCH, TACTILE (RESET)	
S912	1-554-303-21	SWITCH, TACTILE (DISPLAY)	
S913	1-554-303-21	SWITCH, TACTILE (■)	
S914	1-554-303-21	SWITCH, TACTILE (■)	
S915	1-554-303-21	SWITCH, TACTILE (◀◀)	
S916	1-554-303-21	SWITCH, TACTILE (▶▶▶)	
S917	1-554-303-21	SWITCH, TACTILE (EDIT TIME FADE)	
S918	1-554-303-21	SWITCH, TACTILE (CHECK)	
S919	1-554-303-21	SWITCH, TACTILE (CLEAR)	
S920	1-554-303-21	SWITCH, TACTILE	
S921	1-554-303-21	SWITCH, TACTILE (△ OPEN/CLOSE)	
S922	1-554-303-21	SWITCH, TACTILE (▷)	
S923	1-554-303-21	SWITCH, TACTILE (PLAY MODE)	
S924	1-554-303-21	SWITCH, TACTILE (CD SYNCHRO)	
S925	1-554-303-21	SWITCH, TACTILE (TIME)	

PANEL

Ref. No.	Part No.	Description	Remark
S926	1-554-303-21	SWITCH, TACTILE (REPEAT)	
S927	1-571-296-11	SWITCH, SLIDE (DOLBY NR)	
S928	1-571-296-11	SWITCH, SLIDE (DIR MODE)	

MISCELLANEOUS			

7	1-775-368-11	WIRE (FLAT TYPE) (31 CORE)	
11	1-775-369-11	WIRE (FLAT TYPE) (11 CORE)	
23	1-775-370-11	WIRE (FLAT TYPE) (7 CORE)	
24	1-775-371-11	WIRE (FLAT TYPE) (26 CORE)	
121	1-638-983-11	MOTOR FLEXIBLE	
701	1-452-719-11	MAGNET ASSY	
△751	8-848-144-11	DEVICE, OPTICAL KSS-240A	
752	1-575-001-11	WIRE, FLAT TYPE (12 CORE)	
△CNP702	1-558-945-21	CORD, POWER (POLAR. SPT-1) (Canadian)	
△CNP702	1-575-651-21	CORD, POWER (AEP, German)	
HRPE101A-2003-930-A		DECK ASSY, HEAD (PLAYBACK/RECORD/ERASE)	
M1	X-3365-377-2	MOTOR ASSY (CAPSTAN)	
M2	X-3363-501-2	MOTOR ASSY (REEL)	
M101	X-4917-504-1	MOTOR ASSY (SLED)	
M102	X-4917-523-4	BASE (OUTSERT) ASSY (SPINDLE MOTOR)	
M291	A-4604-363-A	MOTOR (L) ASSY (LOADING)	
△T901	1-427-909-11	TRANSFORMER, POWER (Canadian)	
△T901	1-427-910-11	TRANSFORMER, POWER (AEP, German)	

ACCESSORIES & PACKING MATERIALS			

	1-551-734-11	CORD, CONNECTION	
	3-798-627-11	MANUAL, INSTRUCTION (ENGLISH, FRENCH) (Canadian)	
	3-798-627-21	MANUAL, INSTRUCTION (ENGLISH, FRENCH, SPANISH, PORTUGUESE) (AEP)	
	3-798-627-31	MANUAL, INSTRUCTION (GERMAN, DUTCH, SWEDISH, ITALIAN) (AEP)	
	3-798-627-41	MANUAL, INSTRUCTION (GERMAN) (German)	
*	3-907-887-01	CUSHION	
*	3-923-808-41	INDIVIDUAL CARTON (Canadian)	
*	3-923-808-51	INDIVIDUAL CARTON (AEP, German)	
	1-473-359-11	REMOTE COMMANDER (RM-J803)	
	2-181-754-01	COVER, BATTERY (FOR RM-J803)	

HARDWARE LIST			

#1	7-685-871-01	SCREW +BVTT 3X6 (S)	
#2	7-685-133-19	SCREW (DIA. 2.6) (IT3B)	

Ref. No.	Part No.	Description	Remark
#4	7-621-773-95	SCREW +BVTT 2.6X6 (S)	
#5	7-621-775-00	SCREW +B 2.6X3	
#6	7-627-556-08	SCREW +P 2.6X2.8	
#7	7-685-646-79	SCREW +BVTP 3X8 TYPE2 N-S	
#8	7-621-255-15	SCREW +P 2X3	

The components identified by mark △ or dotted line with mark △ are critical for safety. Replace only with part number specified.	Les composants identifiés par une marque △ sont critiques pour la sécurité. Ne les remplacer que par une pièce portant le numéro spécifié.
--	--