



# Technical Manual

.....





---

## IMPORTANT

Please read this manual carefully before connecting your Console to the mains for the first time.

---



This equipment complies  
with the EMC Directive  
89/336/EEC

For further details contact:

Harman International Industries Ltd,  
Cranborne House, Cranborne Road,  
Potters Bar, Hertfordshire, EN6 3JN, UK.

Tel: +44 (0) 1707 665000  
Fax: +44 (0) 1707 660482

© Harman International Industries Ltd. 1999  
All rights reserved

Parts of the design of this product may be protected by worldwide patents.

Part No. ZM0242  
Issue I

Soundcraft is a trading division of Harman International Industries Ltd. Information in this manual is subject to change without notice and does not represent a commitment on the part of the vendor. Soundcraft shall not be liable for loss or damage whatsoever arising from the use of information or any error contained in this manual.

No part of this manual may be reproduced, stored in a retrieval system, or transmitted, in any form or by any means, electronic, electrical, mechanical, optical, chemical, including photocopying and recording, for any purpose without the express written permission of Soundcraft.



Harman International Industries Limited.  
Cranborne House,  
Cranborne Road,  
Cranborne Industrial Estate,  
Potters Bar,  
Herts.,  
EN6 3JN  
UK.

Tel: 01707 665000  
Fax: 01707 660482

# Series TWO

## Contents

<b>Approvals and Notice</b>	<b>2</b>
<b>Safety Symbol Guide</b>	<b>iii</b>
<b>Warranty</b>	<b>v</b>
<b>Important Safety Instructions</b>	<b>vi</b>
<b>Cautions</b>	<b>vi</b>
<b>Warnings</b>	<b>vii</b>
<b>1 Introduction</b>	<b>1.1</b>
<b>2 Installation</b>	<b>2.1</b>
Locating the Console	2.2
Mains Power	2.2
Mains Wiring	2.2
Mains Earthing	2.3
Dimensions	2.4
<b>3 Signal Connections</b>	<b>3.1</b>
Typical System Diagram	3.2
Mating (Cable) Connectors	3.4
Polarity	3.4
Screening	3.4
Connector Wiring	3.4

<b>4</b>	<b>Module Facilities</b>	<b>4.1</b>
	Mono Input	4.2
	Stereo Input	4.5
	Stereo Return	4.6
	Subgroup Output	4.8
	Aux Output	4.9
	Mix/Mono Outputs	4.9
	Matrix Output	4.10
	Monitoring	4.11
	Talkback and Oscillator	4.13
	Output Meters	4.13
	Scene Control	4.14
<b>5</b>	<b>Appendices</b>	<b>5.1</b>
	Appendix A: Scene Control Advanced Information	5.2
	Appendix B: Cable Wiring Diagrams	5.5
	Appendix C: Technical Specifications	5.6
	Appendix D: Input Equaliser Curves	5.7
	Appendix E: Troubleshooting Guide	5.8
	Appendix F: System Block Diagram	5.10
<b>6</b>	<b>Circuit Diagrams and PCB Layouts</b>	<b>6.1</b>
<b>7</b>	<b>Spare Parts</b>	<b>7.1</b>

## Safety Symbol Guide

---

For your own safety and to avoid invalidation of the warranty all text marked with these symbols should be read carefully.



---

### CAUTIONS

Must be followed carefully to avoid bodily injury.

---



---

### WARNINGS

Must be observed to avoid damage to your equipment.

---



---

### NOTES

Contain important information and useful tips on the operation of your equipment.

---



## Warranty

- 1 **Soundcraft** is a trading division of Harman International Industries Ltd .  
**End User** means the person who first puts the equipment into regular operation.  
**Dealer** means the person other than Soundcraft (if any) from whom the End User purchased the Equipment, provided such a person is authorised for this purpose by Soundcraft or its accredited Distributor.  
**Equipment** means the equipment supplied with this manual.
- 2 If within the period of twelve months from the date of delivery of the Equipment to the End User it shall prove defective by reason only of faulty materials and/or workmanship to such an extent that the effectiveness and/or usability thereof is materially affected the Equipment or the defective component should be returned to the Dealer or to Soundcraft and subject to the following conditions the Dealer or Soundcraft will repair or replace the defective components. Any components replaced will become the property of Soundcraft.
- 3 Any Equipment or component returned will be at the risk of the End User whilst in transit (both to and from the Dealer or Soundcraft) and postage must be prepaid.
- 4 This warranty shall only be valid if:
  - A) the Equipment has been properly installed in accordance with instructions contained in Soundcraft's manual; and
  - B) the End User has notified Soundcraft or the Dealer within 14 days of the defect appearing; and
  - C) no persons other than authorised representatives of Soundcraft or the Dealer have effected any replacement of parts maintenance adjustments or repairs to the Equipment; and
  - D) the End User has used the Equipment only for such purposes as Soundcraft recommends, with only such operating supplies as meet Soundcraft's specifications and otherwise in all respects in accordance Soundcraft's recommendations.
- 5 Defects arising as a result of the following are not covered by this Warranty: faulty or negligent handling, chemical or electro-chemical or electrical influences, accidental damage, Acts of God, neglect, deficiency in electrical power, air-conditioning or humidity control.
- 6 The benefit of this Warranty may not be assigned by the End User.
- 7 End Users who are consumers should note their rights under this Warranty are in addition to and do not affect any other rights to which they may be entitled against the seller of the Equipment.

**Series TWO**

**1**

**Introduction**

# Introduction

Thank you for purchasing a Soundcraft Series Two mixing console. The features and facilities found on the Series Two represent a new level of sophistication for a console of this size, offering greater control and higher production values to the console user and owner.

Using the classic eight-bus-eight-aux architecture first pioneered by Soundcraft in the 1970's, the Series Two incorporates state-of-the-art electronic design to achieve outstanding audio quality and flexibility of operation. The Series Two is available in 24, 32 and 40 mono input versions, each with two stereo inputs fitted as standard. The eight subgroups, auxiliary outputs and left/right/mono masters are located at the centre of the console on a single module; inputs are internally modular in blocks of eight. All connections are located at the rear of the console, including dc power connection for the DCP200 power supply unit.

The input pre-amp, which is always the starting point of a good mixing console, is a brand new design and has been optimised for ultra-low noise and improved distortion. A sweepable high-pass filter is available on every mono input to minimise unwanted stage rumble, and high-resolution LED metering gives the engineer clear visual indication of the status of the console's inputs and outputs.

The Series Two is a professional product, designed to give a lifetime's reliable service. This User Guide, as well as describing the console's facilities in detail, also offers some advice on maximising the performance of the entire audio system by the use of good system topology and professional mixing techniques. We hope that you will enjoy many productive hours at your Series Two console; by reading the User Guide now you will be able to make the most creative use of its features.



**Series TWO**

**2**

**Installation**

# Installation

---

The Series Two is designed for reliability and high performance, and is built to the highest standards. Whilst great care has been taken to ensure that installation is made as trouble-free as possible, care taken at this stage, followed by correct setting up, will be rewarded by a long life and reliable operation.

## Locating the Console

---

The console should be located at the best position for the engineer to hear what is being mixed. This is usually in the auditorium within the audience, but may be in a control room. In this case, great care must be taken to position the console centrally in the room, away from large reflective objects, as these can affect the engineer's perception of the live sound. Always ensure that enough space is available behind the console for cable connections, as they may need to be changed from time to time.

*TIP:*

*Though the Series Two may have to be located in a control room, an additional set of connections located in the auditorium may be useful for rehearsals or more complex productions where the positioning of the console is more critical.*

## Mains Power

---

The DCP200 power supply unit, supplied with the Series Two console, is explained in a separate User Guide. Please refer to this document for operational details.



### WARNING

**It is vital that the voltage setting shown on the power supply matches the AC mains supply. Incorrect supply voltage may cause damage and voids the warranty.**

---

The DCP200 is supplied with a suitable mains lead for your region. If for some reason it is necessary to use a different connector, the following wiring code must be used:



## Mains Wiring

---

Connection	Symbol	Wire colour	
Earth:	E or $\perp$	Green and Yellow	(Green and Yellow-US)
Neutral:	N	Blue	(White-US)
Live:	L	Brown	(Black-US)

Please note that for safety reasons, the Earth connection must ALWAYS be made. Power connections and cables should be checked periodically for wear and replaced immediately if damaged. To avoid risk of fire, replace the mains fuse only with the correct value fuse, as indicated on the power supply.

*TIP:*

*To avoid excessive noise appearing at the console's outputs, do not position the console or its power supply adjacent to lighting dimmers or other high-current control gear. The mains connection for the sound system should not be shared with lighting or other control equipment. Ensure that all sound system components are connected to the same phase - if in doubt, consult a qualified electrician.*



## Mains Earthing

A good quality mains earth connection is one of the most important aspects of any sound system installation. In a fixed installation, a 'clean earth' connection should be requested (one which is not shared by any other services and which is taken from the earliest possible point in the building. In a mobile or temporary system, great care should be taken to ensure that the earth connection, like the mains power source, is made at a single point. This enables the installer or system engineer to distribute power and earth connections in a 'star-point' configuration.

The primary function of the earth wire to the audio system is as a safety connection. It is therefore imperative that this remains intact, and has a current-carrying capacity that matches or exceeds the rating of the live and neutral feeds. The earth connection on individual pieces of equipment must NEVER be removed, even though this may temporarily solve a noise problem. Unearthed equipment is potentially DANGEROUS.

### TIP:

*Even though plugging the Series Two power supply or other ancillary equipment into a convenient wall-socket may be tempting, this may destroy an otherwise well-designed earthing system, and is likely to result in increased noise throughout the audio system. Extending the existing audio power distribution system is a better option.*

# Dimensions

Console	Overall Width
24+4 frame	1037mm (40.83")
32+4 frame	1243mm (48.93")
40+4 frame	1449mm (57.04")

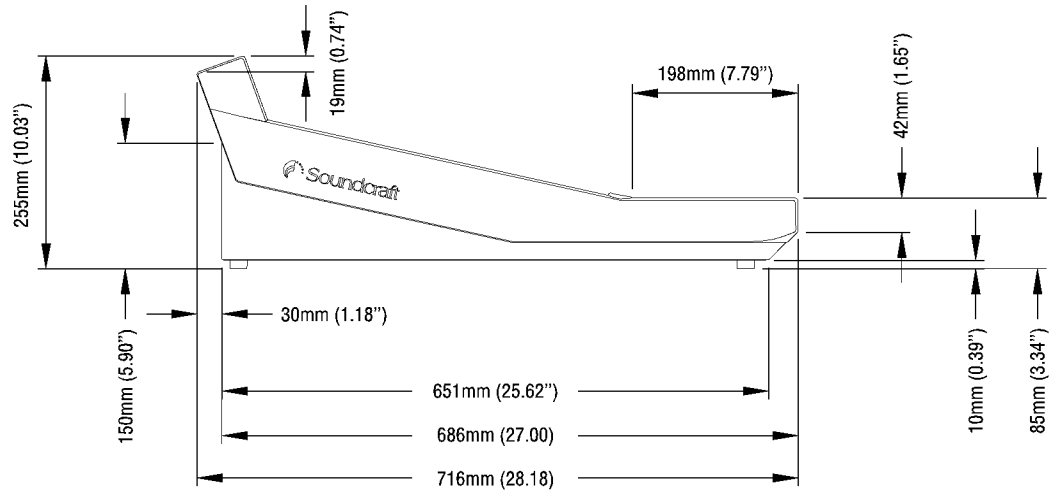

**Series TWO**

**3**

# **Signal Connections**

## Signal Connections

Signal connections to the Series Two fall into three groups; Inputs, Outputs and Inserts. All connections (except for the engineer's headphone socket) are located at the rear of the console.

### Typical System Diagram

This diagram shows how the Series Two may be integrated into a typical sound reinforcement system. For the sake of clarity, only a few examples of external equipment are shown.

Microphones (dynamic and condenser) are on stage, with electronic instruments connected via Direct Inject boxes for balancing and isolation. Inputs may have dynamics processors inserted in their signal path, such as noise gates or compressors. The Direct Outputs may be used to feed a multitrack recorder, or even another console.

The first four Aux mixes are used here for stage monitoring, fed pre-fade from each channel. Other Aux mixes are used as effects sends; a mono mix is connected to a stereo effects processor (most of which are capable of generating a stereo output from a single input). The processor's output is routed to one of the console's Stereo Returns, where it is mixed into the relevant subgroups or main Left/Right masters.

The subgroup outputs themselves are not used in this instance, but a typical application would be an eight-track recording of the grouped signals. The group insert points are used to add dynamics processing (usually compression) to a group of signals, such as backing vocalists, where individual processing is too costly or might be undesirable.

The console's main Left and Right outputs are sent to speaker controllers or crossovers, power amps, and the main PA system, while the Mono output is routed to a separate centre cluster. This may be used to 'localise' vocals and separate them from music programme material. In all three cases, the insert point is used to provide equalisation before the main output faders and meters.

Delays are secondary loudspeaker systems, which are usually fed from matrix outputs, enabling the engineer to modify the mix of signals being sent. The delay system would be used to cover a balcony or other far-field area and requires a time-delay to align its output with the signal from the main system.

The engineer's own monitoring is provided by a pair of small loudspeakers and an amplifier connected to the Monitor L and R outputs. To avoid confusing timing problems, it may be necessary to add a delay (not shown) to these outputs.

It should be stressed that the diagram represents a typical configuration and is by no means the only way to connect a system. Other applications may have different requirements.

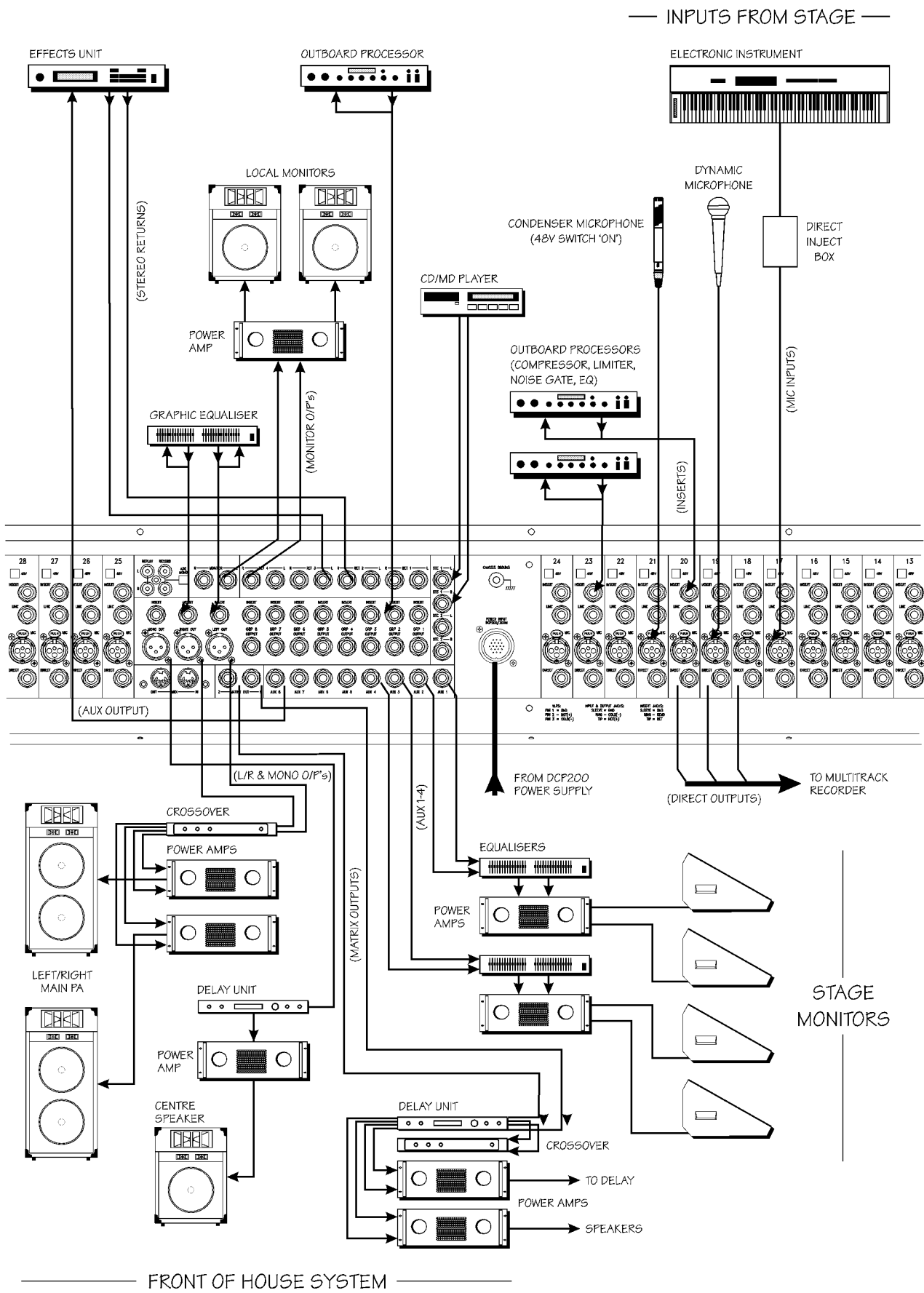

— INPUTS FROM STAGE —

EFFECTS UNIT

OUTBOARD PROCESSOR

ELECTRONIC INSTRUMENT

LOCAL MONITORS

DYNAMIC MICROPHONE

CONDENSER MICROPHONE (48V SWITCH 'ON')

DIRECT INJECT BOX

POWER AMP

CD/MD PLAYER

OUTBOARD PROCESSORS (COMPRESSOR, LIMITER, NOISE GATE, EQ)

GRAPHIC EQUALISER

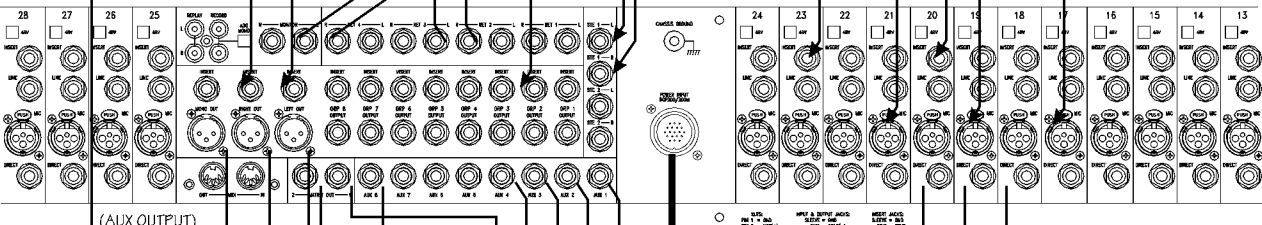

(AUX OUTPUT)

FROM DCP200 POWER SUPPLY

TO MULTITRACK RECORDER

CROSSOVER  
POWER AMPS

LEFT/RIGHT MAIN PA

DELAY UNIT

POWER AMP

CENTRE SPEAKER

EQUALISERS  
POWER AMPS

STAGE MONITORS

DELAY UNIT  
CROSSOVER  
POWER AMPS  
SPEAKERS

— FRONT OF HOUSE SYSTEM —

## Mating (Cable) Connectors

To complete the installation of your Series Two console, you will require the following cable connectors:

Connector type	Console frame size		
	24-channel	32-channel	40-channel
3-pin XLR plug (male)	24	32	40
3-pin XLR socket (female)	3	3	3
3-pole 1/4" jack plug	87	103	119
RCA phono plug	4	4	4

Note that these quantities assume that the 1/4" jack line input connectors on each channel are NOT used.

## Polarity

The installation of balanced connections (where the audio appears as a positive and negative signal on two cores of a 'paired' cable) requires particular care to preserve the correct signal polarity. Even though an incorrectly wired connection may appear to work on its own, the signal may be 'phase inverted', causing enormous problems when it is mixed with other, correctly-wired, signals. Problems with incorrect polarity are most commonly found in multicore cables, so a clear and logical wire colour code should be adopted and documented by the installer.

## Screening

All microphone and line-level signals should be screened; that is, the signal-carrying cores should be covered by a continuous shield of conductive material, usually either copper braid, copper foil or conductive plastic. This helps to prevent the audio signal from being contaminated with unwanted interference from radio signals and nearby high-power equipment.

Under normal circumstances, connecting the screen of the cable, or the 'drain wire' that is connected to the screen, at both ends will give optimum results. However, in some instances, in order to avoid 'hum loops' (screen-borne noise caused by poor equipment earthing), it may be beneficial to disconnect the screen at the receiving end only. It should be understood that this is a last resort; if hum loops are present, earthing the audio equipment properly is the only real solution. Please refer to the earlier section on power connection for more details.

## Connector Wiring

### Microphone Inputs

Each mono input channel is equipped with a balanced microphone input, which uses an industry-standard 3-pin XLR socket, requiring a cable-mounted XLR plug to be used to make the connection. This input is suitable for a wide variety of sources, including low-impedance dynamic, condenser and ribbon microphones, as well as direct-inject (DI) boxes.

The Series Two XLR inputs are wired according to the following standard:

Pin 1	Screen
Pin 2	Hot (+ve signal)
Pin 3	Cold (-ve signal)

When phantom power is switched on using the rear panel switches, 48V dc is supplied to pins 2 and 3 of the XLR. This may be used to provide remote power for condenser microphones or some types of DI boxes.

For connection to an unbalanced source, the XLR plug should be wired as follows:

Pin 1	Screen
Pin 2	Signal
Pin 3	Link to Pin 1

Balanced Mic XLR

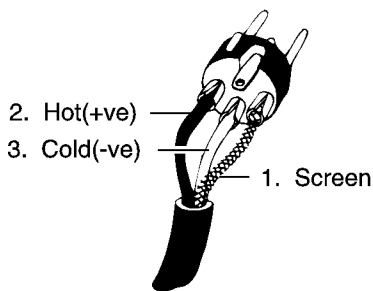

Unbalanced Mic XLR

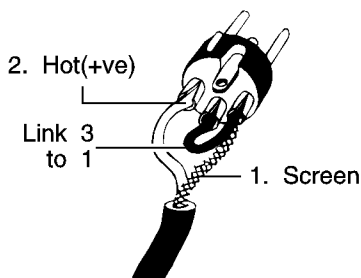





TIP:

Unbalanced microphone-level connections are not suitable for use over long runs of cable, due to their low immunity to interference. Use balanced cables wherever possible to reduce the risk of noise affecting the system.

### WARNING

**Do not use unbalanced connections with phantom power. The voltage between pins 1 and 2 of the XLR connector may cause serious damage.**

Balanced 3 pole Jack      Unbalanced 3 pole Jack

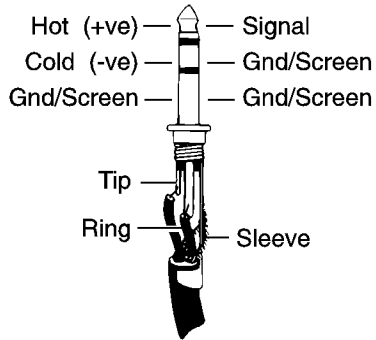

Inserts

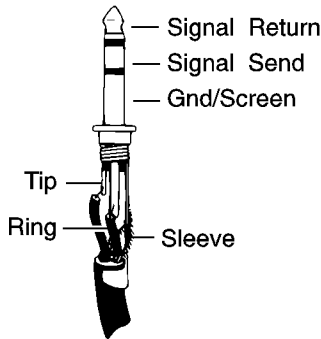

Replay In/Rec Out

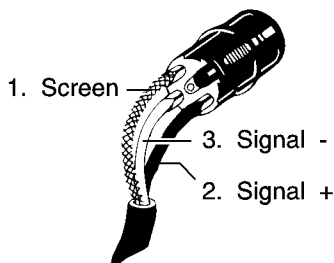
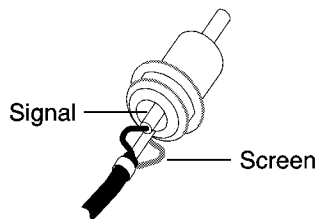

### Line Inputs

Line inputs are available on all mono channels in addition to the two fixed stereo channels at the centre of the console. Other line-level input connections are the four stereo returns, which use eight connectors.

A 3-pole 1/4" tip-ring-sleeve socket is used for balanced line-level inputs, requiring a 3-pole or 2-pole cable-mounted plug. Note that if a 2-pole plug is used, the source will be unbalanced and may be prone to external interference.

Wiring the 1/4" jack should be done according to the following code:

Tip      Hot      (+ve signal)  
Ring     Cold     (-ve signal)  
Sleeve   Screen

For a 2-pole jack, the following convention is used:

Tip      Signal  
Sleeve   Screen

3-pole jacks may be used even if the source and cable are unbalanced. Ensure that the ring and sleeve connections are linked inside the plug.

TIP:

The XLR input is low-impedance and suitable for most professional equipment. Due to the 20dB 'Range' switch fitted to each input, the XLR may also be used with line-level signals. Phantom power is not available on the 1/4" jack connector. In a typical live environment, all lines from the stage would be connected to the console's XLR inputs.

### Tape Replay Inputs

A Stereo Replay input is provided for connection to a tape machine, CD player or other line-level source. This uses RCA phono connectors wired according to the universal standard:

Inner     Signal  
Outer    Screen

### Inserts

Inserts are combined input/output connections, and provide a break in the signal path to allow an external processor (such as a gate, compressor or equaliser) to be used on an individual input or output. The Series Two uses 3-pole 1/4" jacks to provide an unbalanced 'send' and 'return' connection, which share the same cable and screen.

TIP:

Different manufacturers use different standards for insert wiring. Please check before using any existing insert cables with your Series Two console. All Soundcraft professional consoles use the tip of the jack for the return signal, and the ring for the send.

Insert points are available on all Mono Inputs, subgroups 1-8 and the Left/Right/Mono masters. The wiring for cable connectors is as follows:

Tip      Return            Input to the console  
Ring     Send                Output from the console  
Sleeve   Screen

### Mix & Group Inserts

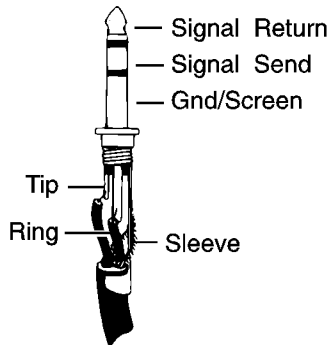

### Group Outputs Matrix Outputs Aux Outputs Direct Outputs

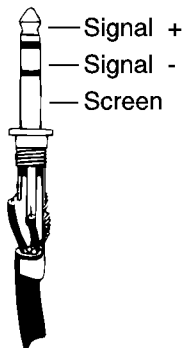

### Headphones

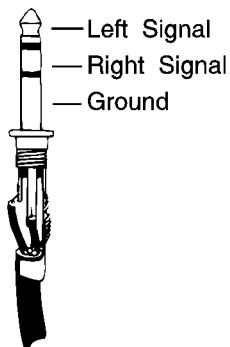

### TIP:

The Series Two sends a permanent, pre-fade signal to the 'send' connection, enabling the user to tap off a feed of a channel, group or master. This can be done by using a 3-pole jack with the tip and ring shorted to keep the signal path intact.

### Balanced Outputs

The centre section of the Series Two contains the console's outputs; these are electronically balanced for optimum immunity to external noise. Primary outputs (Left, Right and Mono master busses) utilise 3-pin XLR connectors; the cable-mounted mating sockets should be wired as follows:

Pin 1	Screen
Pin 2	Hot (+ve signal)
Pin 3	Cold (-ve signal)

Impedance-balanced outputs are provided on 3-pole 1/4" jack sockets for Subgroup 1-8, Aux 1-8, Matrix 1 and 2, and Monitor Left and Right. Each mono channel also has an impedance-balanced direct output. These should be wired to the standard pin-out:

Tip	Hot (+ve signal)
Ring	Cold (-ve signal)
Sleeve	Screen

### TIP:

If the external device that is receiving the console output is unbalanced, the best result will be obtained by using paired, screened cable. Connect the tip of the 1/4" jack to the 'hot' (+ve signal) core, with the sleeve (and ring, if using a 3-pole plug) connected to the 'cold' (-ve) core and screen. It may be advantageous to connect the cable screen at the console end ONLY.

### Unbalanced Outputs

The only unbalanced line-level outputs provided by the Series Two are the Left and Right Record outputs, which use RCA phono connectors. Cable plugs should be wired in the same way as the Tape Replay connectors, shown on the previous page.

### Headphone Output

The engineer's headphone socket is located on the front panel, near the group faders at the centre of the console. It is wired to standard industry convention and is compatible with most stereo headphones. Should it be necessary to re-wire a headphone cable, the following pin-out should be used:

Tip	Left (often a white wire)
Ring	Right (usually a red wire)
Sleeve	Screen

**Series TWO**

**4**

# **Console Facilities**

# Console Facilities

The Series Two's features are divided into the following sections:

- Mono Input
- Stereo Input
- Stereo Return
- Group Output
- Aux Output
- Master Output
- Matrix Output
- Monitoring
- Talkback and Oscillator
- Scene Control

## Mono Input

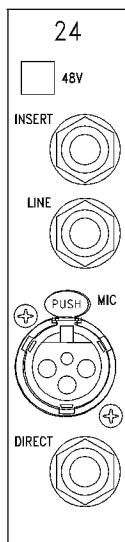

## Connections (Rear Panel)

The Mono input is fitted with a 3-pin XLR (low-impedance signals) and 3-pole 1/4" jack (high-impedance signals). Plugging a jack into the Line jack will override any signals connected to the XLR input. The Line jack is isolated from phantom power, even if this is switched on. Another 3-pole 1/4" jack socket provides the pre-EQ insert point, while a third socket is used for the channel's direct output. This signal is normally post-fade but may be switched to pre-fade (post EQ) by the DIR PRE button on the front panel.

## 48V Switch

48V dc phantom power is available on the input XLR connector only, and is activated by the rear-panel 48V switch, located above the Insert connector.

*TIP:*

*Do not plug microphones in with the phantom power switched on, as this may damage some types of microphone. Always check the status of the rear panel switch before connecting a source to the Series Two.*

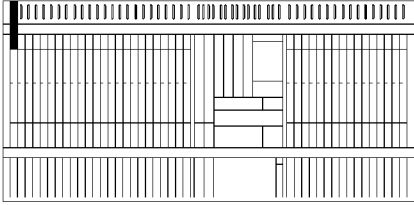

### Input Level Meter

Each Mono Input has a 12-segment LED bargraph meter, located in the raised meter bridge above the channel. This indicates the pre-fade, post-EQ signal (in other words, it will be affected by any EQ or outboard processing used, but not by the fader or mute switch).

The PK (Peak) LED at the top of the meter shows the peak level at the insert send and pre-fade points - if the signal at either of these key points reaches 3dB below clipping, the PK LED will stay lit for a short period.



### SENS control

The input sensitivity may be varied from -60dBu to -15dBu using this rotary control. The SENS rotary control should normally be set so that the loudest signal peaks do not quite illuminate the PK indicator at the top of the input level meter. This will ensure that there is enough gain added to the input signal, to maximise the signal to noise performance without clipping the internal circuitry.

### -20 Switch

When depressed, this switch reduces the sensitivity of the input stage by 20dB. This allows high-level signals (up to +26dBu) to be adjusted via the SENS control for optimum level. Unlike many mixers, this is not a 'pad' (which can have a detrimental effect on the signal), but gives the SENS control an overall range of -60dBu to +26dBu.

### Ø Switch

This switch is used to reverse the phase of the input signal to compensate for incorrect wiring or microphone placement.

*TIP:*

*If using two microphones on a snare drum (one positioned above and one below the drum), reversing the phase of the lower microphone will prevent any low-frequency cancellation between the two inputs, and will give a fuller, richer sound.*

### H/P Controls

Each Mono Input is provided with a variable-frequency High Pass Filter, which may be activated by the H/P switch. The filter will progressively remove all signal below the frequency selected by the rotary control, which has a range from 40Hz to 400Hz. The 'slope' of the filter is 12dB per octave; in other words, if the rotary control is set to 120Hz, the frequency response of the channel will be -3dB at 120Hz, -15dB at 60Hz and -27dB at 30Hz. The HP filter can be used to remove stage rumble from sources that do not require low-frequency information, or to reduce 'popping' on vocal microphones.

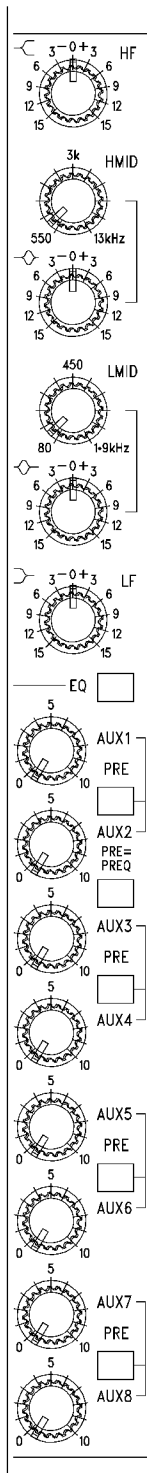
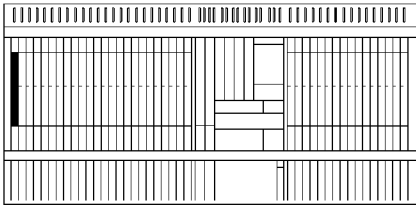

## Equaliser

The equaliser fitted to the mono input is a four-band design, with fixed frequency high and low-frequency bands, plus variable frequency high-mid and low-mid sections. The four bands are defined as follows:

Type	Control Band	Frequency Range	Cut/Boost
HF	High	12kHz	+/- 15dB Shelving
HMID	High-Mid	550Hz - 13kHz	+/- 15dB Peak/Dip
LMID	Low-Mid	80Hz - 1.9kHz	+/- 15dB Peak/Dip
LF	Low	60Hz	+/- 15dB Shelving

The HF and LF sections are equipped with a single cut/boost control, which has a centre detent. The HMID and LMID sections have an additional rotary control, which is used to vary the centre frequency of the cut or boost curve.

See Appendix D for EQ curves.

*TIP:*

*When using the equaliser to reduce the level of an excessively loud group of frequencies, it is advisable to use the cut/boost control to first emphasise the frequency. Sweep the centre-frequency to identify the worst sound; then turn down the level of the cut/boost control until the frequency band is sufficiently reduced.*

An overall EQ in/out switch is provided, allowing the engineer to bypass the equaliser controls if required.

## Auxiliary Sends

The Series Two provides eight aux mixes, which may be used to generate special feeds for stage monitoring, backstage foldback or effects sends for reverb units, etc.

Aux 1-8 are normally post-fade (their level is affected by the channel fader position), but each pair of aux sends may be selected to be pre-fade (post-EQ) by a switch located between each pair of controls. The pre-fade point may be changed to be pre-EQ by depressing the PRE=PREQ switch.

Typical uses for the three aux types are as follows:

<b>Post fade</b>	Send to effects unit	Effects mix is based on original signal mix levels
<b>Pre fade/Post EQ</b>	Stage monitoring	Level is set independently of FOH mix but is EQ'd
<b>Pre fade/Pre EQ</b>	Monitoring/Recording	Offers a fixed, uncorrected feed of input signals

Whether the aux sends are selected to be pre or post-fade, they are always muted by the channel MUTE switch (see below). Pre-fade sends (whether pre or post EQ) are taken post-insert, so are affected by any external processing that may be in use.

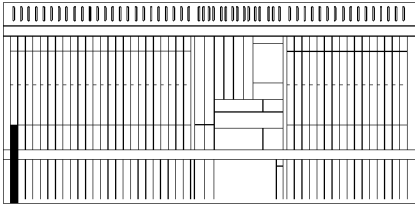

## Routing and PAN Controls

The Series Two benefits from having eight subgroups for sub-mixing inputs before generating a final output mix. Each input channel may be routed to the subgroups in pairs using the four switches (1-2, 3-4, 5-6, 7-8).

Direct routing to the stereo master outputs is achieved by the MIX switch, while the MONO switch sends the signal to the mono master output.

The rotary PAN control is used to vary the relative levels of the input being fed into the left (or odd) and right (or even) outputs. This control affects all subgroups and the stereo master outputs. At its centre point, the pan control feeds the signal to both busses at -4.5dB. When the control is turned fully clockwise, the signal is sent to the even groups only; when fully counterclockwise, only the odd groups are fed.

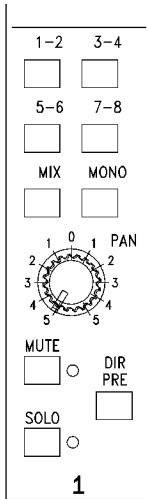

### MUTE Button

The Mute switch cuts the signal to the group and master mixes, as well as any pre or post-fade aux sends. The LED next to the button is used to indicate that the mute is activated. This can be done by pressing the button or through the Scene Control system (see Scene Control, Page 4.19).

In certain circumstances, the MUTE LED is used to indicate that the channel is 'Mute Safe' (it is not affected by the automation system). Please refer to Scene Control for an explanation of this function.

### DIR PRE Button

This is used to select the direct output to be pre-fade (pre-mute). This is particularly useful for recording a live performance; individual channels may be sent to a multitrack recorder using the pre-fade direct output, safe in the knowledge that the tape level will be unaffected by the mix required for the live sound.

If the button is not pressed, the direct output receives a post-fade signal.

### SOLO Button

The normal function of this button is to provide a pre-fade listen feed of the channel to the engineer's headphones (which is displayed on the MONO/PFL meter). In this way, inputs may be checked while the performance or rehearsal is in progress, without interrupting the feed to the main system. However, if the SIP function is active (see Solo-In-Place), the SOLO button allows the channel to be heard exclusively at the main outputs. All channels that do not have their SOLO buttons pressed are muted. In this mode, the input signal is heard post-fade, and is affected by the PAN control. An active SOLO is shown by the adjacent LED, and also by the PFL/AFL LED on the master section.

### Channel Fader

Mono Inputs are fitted with 100mm long-throw faders that control the level of signal being fed to the groups, the Left/Right/Mono masters and any post-fade auxes. At its lowest point, the fader effectively mutes the signal, while at the top of its travel, it can be used to add 10dB of gain to the channel's level. The optimum level, however, is at or close to the '0' mark. This represents 0dB or 'unity gain' - the signal passes through the fader without changing level.

*TIP:*

*The area around the 0dB point on the fader is designed to allow the engineer to make fine adjustments to the mix. If you are operating the console with the fader near the bottom of its travel, you should use the SENS control or -20 switch to decrease the input level.*

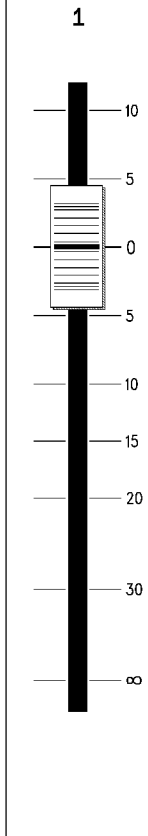

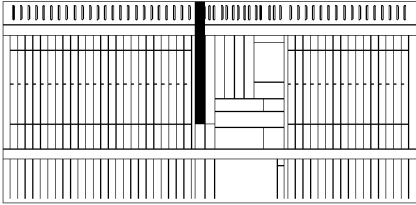

## Stereo Input

Two fully-featured Stereo Inputs are fitted to the Series Two, adjacent to the central output section. Typical uses would be inputs from line-level playback devices (CD or MD players, tape machines), submixes from other sources, such as a sequencer or keyboard mixer, or returns from stereo effects units.

## Connections (Rear Panel)

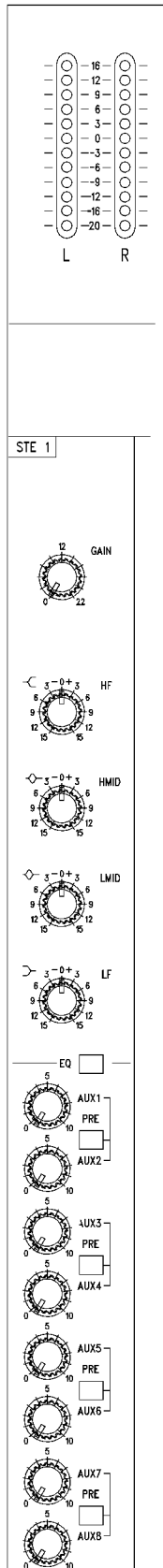

Each Stereo Input is fitted with two balanced 3-pole  $\frac{1}{4}$ " jacks and will accept line level balanced or unbalanced signals.

## Input Level Meter

Each Stereo Input has a pair of 12-segment LED bargraph meters, located in the raised meter bridge above the channel. These indicate the left and right pre-fade, post-EQ signal (in other words, they will be affected by any EQ or outboard processing used, but not by the fader or mute switch).

## GAIN control

The line input gain may be varied from 0dB to +22dB using this rotary control. The GAIN rotary control should normally be set so that the loudest signal peaks do not quite illuminate the top LED of the input level meters. This will ensure that there is enough gain added to the input signal, to maximise the signal to noise performance without clipping the internal circuitry.

## Equaliser

The equaliser fitted to the Stereo Input is a four fixed-band design, with carefully selected high, high-mid, low-mid and low-frequency bands. All four sections are equipped with a single cut/boost control, which has a centre detent.

The EQ controls provide +/-15dB of cut or boost at frequencies of 12kHz, 3kHz, 320Hz and 60Hz respectively.

An overall EQ switch is provided, allowing the engineer to defeat the equaliser controls if required. This may be used to compare the equalised and 'raw' signal to verify that using the EQ has improved the sound.

## Auxiliary Sends

All eight aux mixes are accessible from the Stereo Input; the stereo signal is summed to mono before being routed to these busses.

As with the Mono Input, aux sends are normally post-fade (their level is affected by the channel fader position), but each pair of sends may be selected to be pre-fade (post-EQ) by a switch located between each pair of controls.

Whether the aux sends are selected to be pre or post-fade, they are always muted by the channel MUTE switch (see next page).



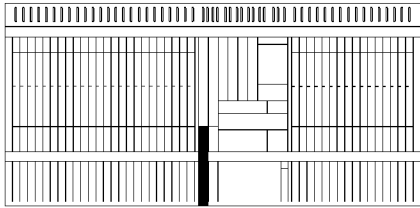

## Routing and BAL Controls

Stereo inputs may be routed to the eight subgroups for sub-mixing or to the stereo (Left/Right) masters. Stereo inputs are routed so that the Left channel is sent to the odd groups, while the Right side is fed to the even busses using the five switches (1-2, 3-4, 5-6, 7-8, MIX).

The rotary BAL (Balance) control is used to vary the relative levels of the input being fed into the left (or odd) and right (or even) outputs. This control affects all subgroups and the stereo master outputs.

At its centre point, the BAL control feeds the signal to the busses at 0dB (unity gain). When the control is turned fully clockwise, the signal is sent to the even groups only and is boosted by 4dB; when fully counterclockwise, only the odd groups are fed.

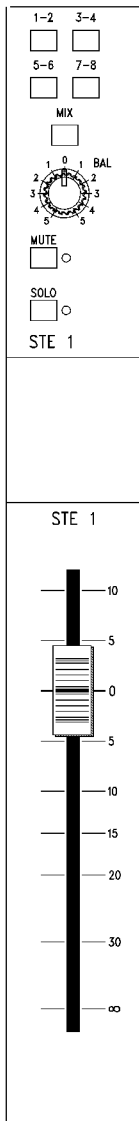

## MUTE Button

The Mute switch cuts the signal to the group and master mixes, as well as any pre or post-fade aux sends. The LED next to the button is used to indicate that the mute is activated. This can be done by pressing the button or through the Scene Control system ( see Scene Control, Page 4.19 ).

In certain circumstances, the MUTE LED is used to indicate that the channel is 'Mute Safe' (it is not affected by the automation system). Please refer to Scene Control for an explanation of this function.

## SOLO Button

The normal function of this button is to provide a mono pre-fade listen feed of the channel to the engineer's headphones and the MONO/PFL meter. In this way, inputs may be checked while the performance or rehearsal is in progress, without interrupting the feed to the main system. However, if the SIP function is active (see Solo-In-Place), the SOLO button allows the channel to be heard exclusively at the main outputs. All channels that do not have their SOLO buttons pressed are muted. In this mode, the input signal is heard in stereo, post-fade, and is affected by the BAL control. An active SOLO is shown by the adjacent LED.

## Channel Fader

Stereo Inputs are fitted with 100mm long-throw stereo faders that control the level of signal being fed to the groups, the Left/Right masters and any post-fade auxes.

## Stereo Return

The Series Two is fitted with four stereo returns (RET1 - RET4), which accept line-level signals and may be used for submix inputs, effects returns, or as additional stereo inputs if required.

### Connections (Rear Panel)

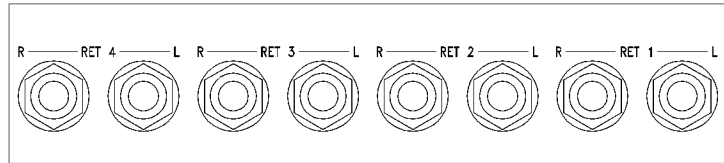
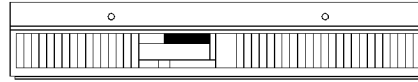

Each Stereo Return is fitted with a pair of balanced 3-pole 1/4" jacks as input connectors. Balanced or unbalanced line-level signals may be used.

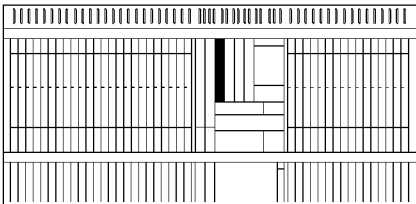

### GAIN Control

Input gain may be adjusted from 0dB to +22dB using this rotary control. The GAIN rotary control should initially be set so that when the Stereo Return PFL button is pressed (see below), the normal level shown on the PFL/MONO meter is around the '0' mark.

### TILT Control

This rotary control provides a tone control function over the stereo return signal. When turned clockwise, the level of high frequencies is boosted by up to 6dB, while low frequencies are attenuated by a similar amount. Turning the control counterclockwise increases the low-frequency content and reduces the HF level.

*TIP:*

*This function may be used to 'brighten' signals being sent from effects units by boosting the high-frequency level - but beware of increasing the noise generated by outboard devices.*

### Aux Sends

Four rotary controls are provided on the Stereo Return for creating aux sends - these are shared between pairs of auxes, selected by two switches (3-4 and 7-8). With no switches pressed, the four controls route the signal to Aux 1, 2, 5 and 6. All aux sends from the Stereo return are post-fade.

*TIP:*

*Great care should be taken when using the Stereo Returns as effects inputs to avoid sending a Return signal back to the aux mix that is used to feed the effect unit. This will create, at best, strange effects, and at worst will cause a feedback loop that will be uncontrollable.*

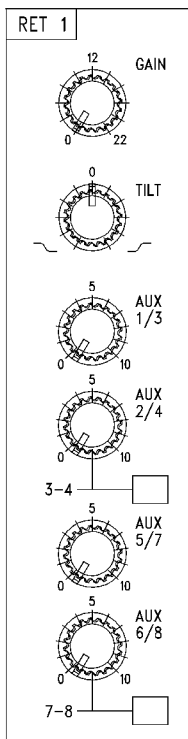

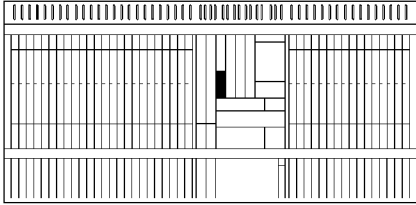

## Routing Switches

The Stereo Return signal is routed in stereo using the subgroup (1-2, 3-4, 5-6, 7-8) and MIX buttons. Routing is post-fade and post-mute.

*TIP:*

*Where a group of signals has been sent to an effects mix, routing the associated Stereo Return into the same subgroup instead of directly to mix will ensure that the effects level is mixed at a constant level with the original signals.*

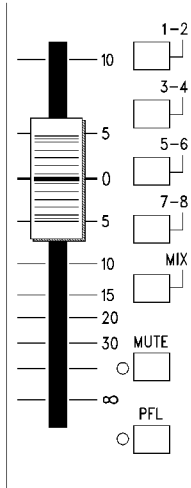

## MUTE Switch

As with other inputs, the MUTE switch affects the subgroup and Left/Right master feeds, as well as the aux sends. The LED next to the button is used to indicate that the mute is activated, either by pressing the button or through the Scene Control system ( see Scene Control, page 4.19 ).

In certain circumstances, the MUTE LED is used to indicate that the channel is 'Mute Safe' (it is not affected by the automation system). Please refer to Scene Control for an explanation of this function.

## PFL Switch

This sends a mono sum of the pre-fade Stereo Return signal to the Monitoring outputs (see below) and the PFL/MONO meter. The PFL buttons cannot be used to generate a Solo-in-Place function, if this has been enabled.

## Stereo Return Fader

Stereo Returns are fitted with 60mm faders, with a range from +10dB to  $-\infty$ dB (muted). The fader affects the level sent to the subgroups, Left/Right masters and aux mixes.

## Subgroup Output

The Series Two is an 'eight-bus' console, meaning that it has eight discrete subgroups. These may be used to create mono mixes of signals, or may be paired to generate stereo sub-mixes. Typically, these would be used to group instruments in logical sections; for example, the numerous microphones used to cover a choir can be allocated to a stereo subgroup, allowing the engineer to use the channel PAN controls to make up a stereo submix. During the show, if the level is too high or low, the entire choir can be adjusted using just two faders.

## Connections (Rear Panel)

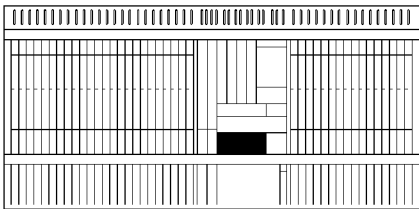
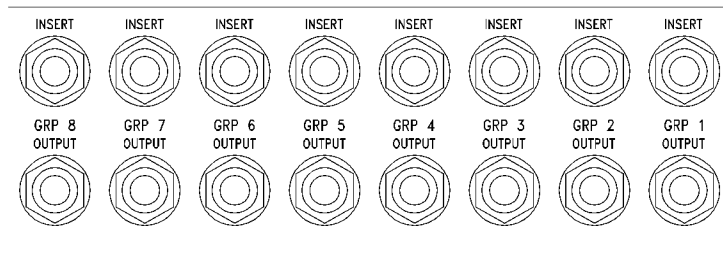
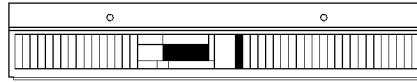

Subgroup outputs are available on the rear panel via balanced 3-pole 1/4" jack sockets. These outputs may be used for 8-track recording, or for sending the subgroup mixes to another console.

Each subgroup also has an insert point; this uses another 3-pole 1/4" jack, wired according to the same convention as the input insert points (see Signal Connections).

## Routing and PAN Controls

The subgroup output is fed to a rear-panel connector, but may also be routed into the stereo (Left/Right) masters and/or the Mono master, using the MIX and MONO buttons. When sending the subgroup to the MIX masters, the PAN control affects the signal's placement in the stereo field.

*TIP:*

Where two subgroups are used as a stereo pair, the 'width' of the stereo mix may be varied by using the two associated PAN controls. Also, varying one of the PAN controls will alter the 'position' of the stereo pair in the main mix, by biasing the image to the left or right.

## PFL Button

This is used to send a pre-fade subgroup signal to the Monitoring section (see below). This function is not affected by Solo-in-Place.

## Insert Point

Each subgroup has a pre-fade insert point, which may be used to add an external processor (such as a compressor/limiter) to the signal path. This is especially useful where the amount of external processing is limited, or where it is important that a group of signals requires the same process. A typical example is a stereo multiple-keyboard submix; it is more important to maintain a constant keyboard level than to compress each instrument individually.

*TIP:*

Since the 'send' of the insert point is constantly live, it is possible to use the insert point as a pre-fade subgroup output, for example for a constant-level multitrack recording of a live performance. However, care must be taken when wiring the cables to ensure that the signal is fed back into the 'return' of the connector.

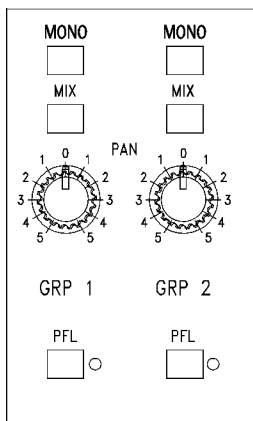

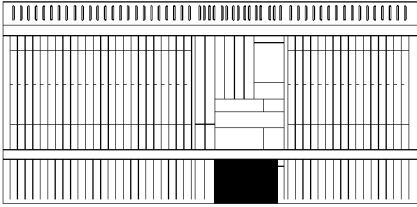

### Subgroup Fader

Each subgroup has a 100mm long-throw fader, which affects the level being sent to the Left/Right/Mono masters, as well as the rear panel output connector. The fader allows up to +10dB of gain and will effectively mute the signal at the bottom of its travel.

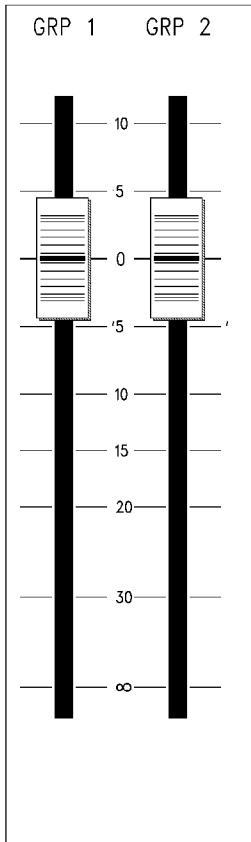

## Aux Output

---

### Connections (Rear Panel)

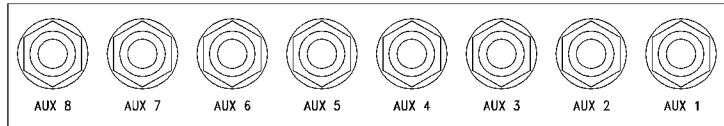
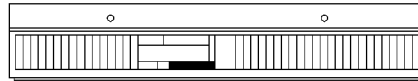

Each aux output is equipped with a 1/4" 3-pole jack socket, which provides a balanced, line-level output of the aux mix.

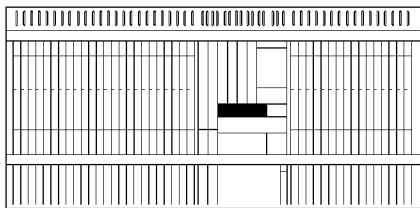

### Aux Master Level Control

The Series Two is equipped with eight rotary Aux Master controls, which vary the output level of the mix from 0dB to  $-\infty$ dB (off).

### AFL Button

This sends a post-master fader aux signal to the Monitoring section and to the PFL/MONO meter, allowing the engineer to check that the output level is correct. This is not affected by the Solo-in-Place function.

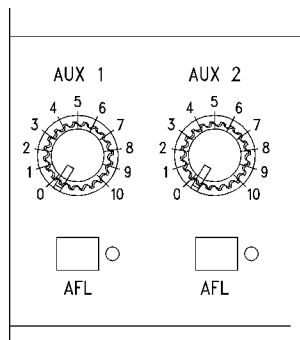

## Mix/Mono Outputs

### Connections (Rear Panel)

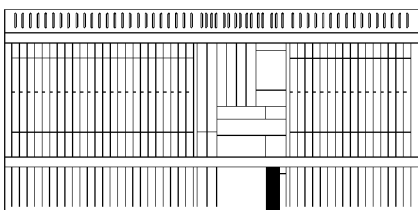
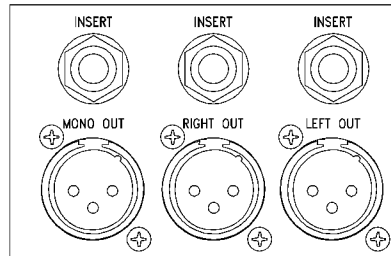
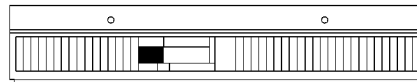

The Series Two has three master busses; Left, Right and Mono. These appear on 3-pin XLR connectors and are balanced, line-level signals. Each master bus also benefits from a pre-fade insert point, available on a 3-pole 1/4" jack socket.

### Insert Point

The pre-fade insert point is used to add external processing (such as a graphic equaliser) to the signal path of the master outputs. Placing outboard equipment at this point in the signal chain is important, as it enables the engineer to make level corrections after the processing has been done. Also, with a processor inserted before the fader, the true signal level is being shown on the output meters.

### MIX/MONO Faders

The Left/Right outputs share a stereo 100mm long-throw fader, which affects the level being sent to the rear panel output connector. Similarly, the Mono output has a separate 100mm fader. The faders allow up to +10dB of gain and will effectively mute the signals at the bottom of their travel.

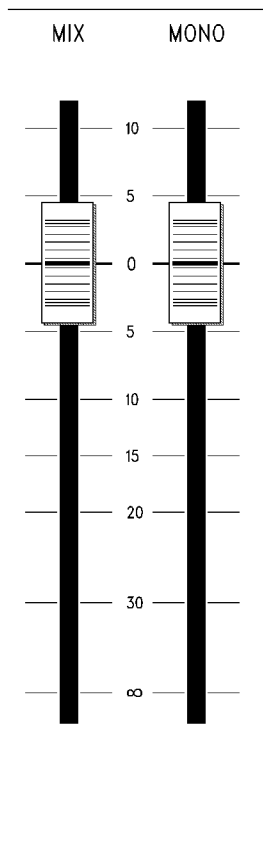

## Matrix Output

### Connection (Rear Panel)

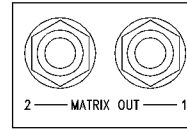
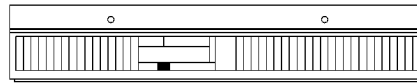

The Series Two's Matrix outputs (1 and 2) are provided with balanced 3-pole 1/4" jacks for connection to delay systems or other ancillary equipment.

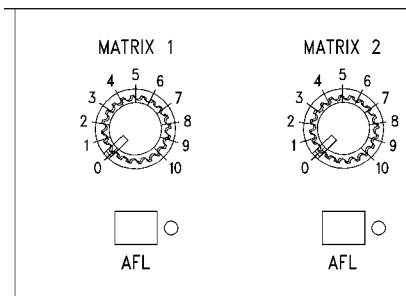
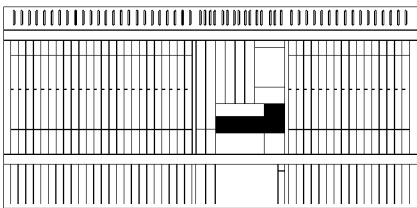

### Send Controls

The eight subgroups, as well as the Left/Right/Mono masters, are able to access the two-output matrix via the rotary controls located above the subgroup outputs. These have a range from 0dB (unity gain) to  $-\infty$ dB(off). The feed to the matrix is post-fade (post-mute) in each case.

### Master Controls and AFL

Matrix 1 and 2 have overall rotary level controls, which can be used in association with the AFL button to ensure that the correct level is being sent. The AFL button routes the post-fade signal to the Monitoring section and the MONO/PFL meter.

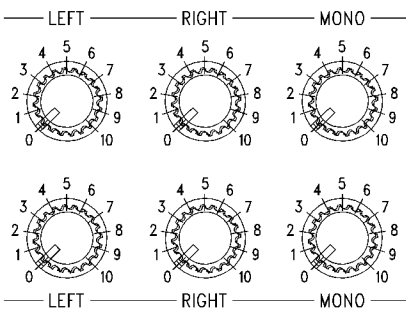



## Monitoring

This section provides the engineer with the controls and functions to check that the console is operating at the correct signal levels. Dedicated metering and a separate audio output mean that monitoring may be carried out while a performance is in progress, without interrupting or affecting the main outputs. A stereo monitor output is available for connection to a local amplifier and speakers, enabling the engineer to listen to any PFL/AFL/SOLO selection.

### Connections (Rear Panel)

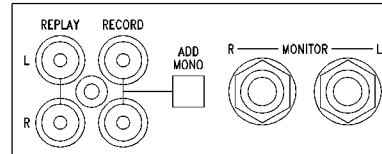
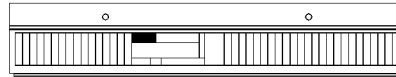

The balanced, line-level Monitor output is available on a pair of 3-pole 1/4" jacks (MONITOR L and R). A REPLAY input and RECORD output, also in stereo, are provided on RCA Phono connectors.

*TIP:*

*Though the Monitor outputs are provided in stereo, the stereo effect will only be heard if Solo-in-Place is used, if the Replay input is monitored, or if the stereo mix is being monitored inside an isolated booth or remote area. If these are not required, a mono amplifier and single speaker will suffice.*

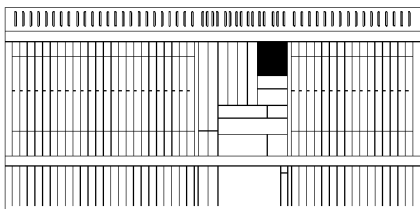

### Replay Section

The Replay inputs may be used for any playback device such as a CD, MD or tape machine. Using these inputs avoids having to allocate a full stereo input for a device where no EQ is required.

There is also a Record output, in stereo, which is a duplicate feed of the Left/Right outputs, but at a reduced level suitable for most cassette or MD recorders.

*TIP:*

*If recording a performance on a stereo machine, the Replay inputs can be used to return the off-tape signal to the console for monitoring.*

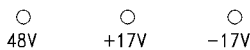

### ADD MONO Switch (Rear Panel)

This allows the output of the Mono master to be summed with the Left/Right mix before being sent to the recording device, via the RECORD connectors. This allows signals routed to a centre cluster, but not to the main mix, to appear in the recording as if they were panned centrally.

### Replay Level

This rotary control affects the level of the Replay input and is the only level control before the signal reaches the MIX busses.

### REPLAY TO MIX Switch

This routes the post-level-control Replay signal to the Left/Right master busses. Note that this switch should not be activated if the Replay input is being used for off-tape monitoring.

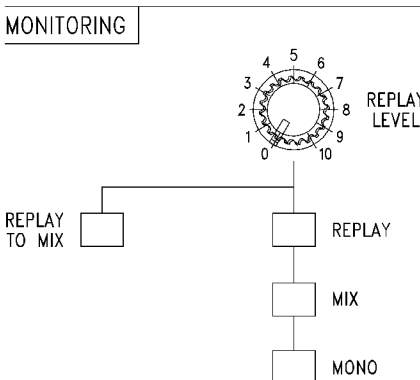

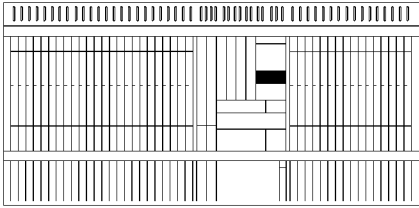

## Monitor Selection Switches

The REPLAY, MIX and MONO switches are used to select the normal source for the stereo Monitor output. This selection will be overridden by any PFL, AFL or SOLO button being activated.

*TIP:*

*If you do not require a 'default' feed to be sent to monitors, deselect all three of these switches. This will mean that a signal is only present on the Monitor outputs when a PFL/AFL/SOLO button is pressed, and means that there is never any doubt as to what is being monitored.*

## SOLO-IN-PLACE

Solo-in-Place effectively replaces the entire Left/Right mix output with an individual signal, enabling the engineer to hear the isolated input in its correct position in the stereo image (with effects returns if necessary).

The SIP function is made 'ready' by pressing the Solo-in-Place switch; this lights the amber warning LED. Following this, pressing any channel SOLO button will activate the system, as indicated by the adjacent red LED.

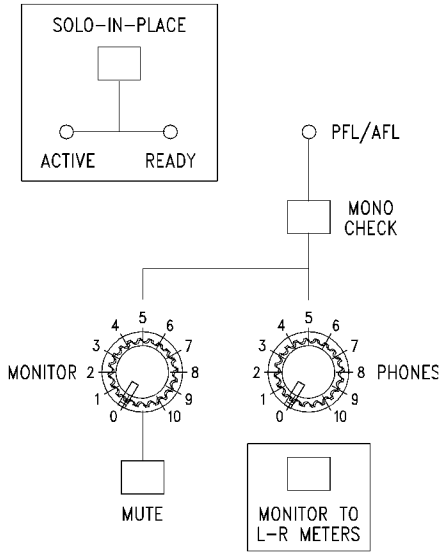

### WARNING:

**This function should never be selected during a performance, as the soloed input(s) will be heard by the entire audience. Always make sure that the 'READY' LED is not lit before starting a show.**

## PFL/AFL LED

This LED is illuminated whenever a PFL, AFL or SOLO button is pressed anywhere on the console. It provides a very useful indication to the engineer that the normal Monitor output has been replaced by a different signal.

## MONO CHECK Switch

This switch sums the left and right halves of any stereo signal to ensure that they are 'mono-compatible'. This applies to whatever has been selected on the monitor selection switches: ie, Replay, mix or a Solo-in-Place.

*TIP:*

*Some stereo signals may have phase problems that do not show up when monitoring in stereo. Summing the left and right signals together is the simplest way of checking that should it ever be required in mono, the signal will be heard correctly. If this is not the case, the phase of one half may have to be inverted.*

## MONITOR and PHONES Controls

These two level controls affect the signals being sent to the line-level and headphone outputs respectively. Additionally, the line-level output has a MUTE switch, which does not affect the headphone output.

## MONITOR TO L-R METERS Switch

To provide visual confirmation that a stereo signal (eg: Replay input) is well-balanced (ie., that the levels of the Left and Right signals are not too different), the signal feeding the L and R master meters may be replaced by the stereo Monitor output. Note that this feed is pre-level-control. Great care should be taken to ensure that this switch is not accidentally left pressed when the MONITOR TO L-R METERS facility is not required. This ensures that the L and R master meters continuously monitor the main mix output, and are not interrupted by solos or selection of other monitor sources.

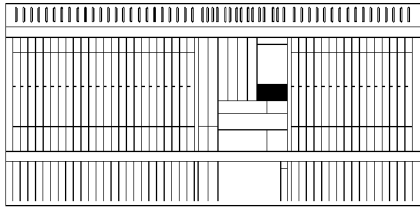

## Talkback and Oscillator

Communications are a vital part of a successful production, and the Series Two allows the engineer to access the most important outputs to talk to artists or crew members. An on-board oscillator is also provided to line up any outboard equipment connected to the console.

### MIC Connection (Front Panel)

The engineer may use a gooseneck dynamic microphone for talkback; this avoids having to use a full input channel for this purpose.

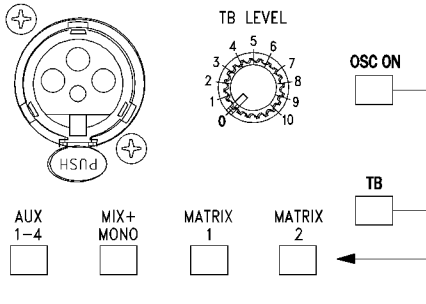

### TB Level

The gain of the Talkback mic amp may be varied to match the microphone level.

### TB/OSC ON Switches

These switches are used to select whether Talkback or the on-board oscillator is sent to the routing switches. Pressing the momentary TB switch allows the talkback microphone signal to be sent to the busses preselected by the routing switches below. Selecting the OSC ON switch overrides the Talkback microphone, and activates a 1kHz fixed-level tone for line-up purposes.

### TB/OSC Routing

Four latching routing switches are provided (AUX 1-4, MIX+ MONO, MATRIX 1 and MATRIX 2). These are used to pre select the busses that will receive the Talkback or Oscillator signal.

*TIP:*

*In a typical live setup, Aux 1-4 would be used as pre-fade outputs for on-stage monitoring or foldback. Allocating these aux mixes in this way allows the engineer to talk to the stage using the Talkback routing.*

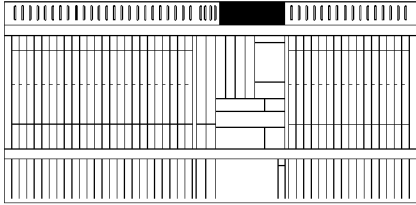

## Output Meters

### Subgroup Meters

Each subgroup has a dedicated 12-segment LED bargraph meter, which displays the post-fade (post-insert) output level. This enables the engineer to see the actual signal leaving the console, or being fed into the Left/Right/Mono master busses. A reading of '0' corresponds to an output level of +4dBu. The meters have a peak reading response, ie. a very fast attack, but slow decay time.

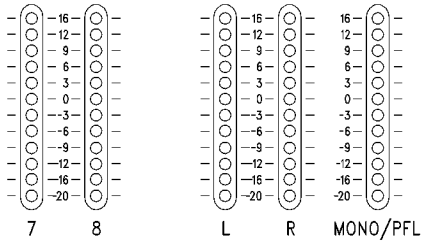

### L/R Meters

These meters are normally dedicated to the Left/Right outputs, displaying the post-fade, post-insert level. However, by pressing the MONITOR TO L-R METERS button located in the Monitoring section (see page 4.16), these meters can be re-assigned to show the stereo monitor output.

A reading of '0' corresponds to an output level of +4dBu. The meters have a peak reading response.

### MONO/PFL Meter

With no PFL/AFL/SOLO buttons pressed, this meter shows the Mono master output level in the same way as the adjacent Left/Right meters. As soon as any AFL, PFL or SOLO button is activated, the meter switches to show the level of the selected input or output. If this is the case, the PFL/AFL LED on the Monitoring section (see above) will be illuminated.

A reading of '0' corresponds to an output level of +4dBu. The meters have a peak reading response.

#### TIP:

The top LED of the output meters (labelled '16') represents an output of +20dBu, which is within 4dB of the maximum level. If this LED is frequently lit, the output signal may be 'clipped', which will cause audible distortion, and may also overload whatever equipment is connected to the output. A 'safe' operating level would show a normal signal at around 0, with any occasional peaks not quite reaching the last LED of the meter.

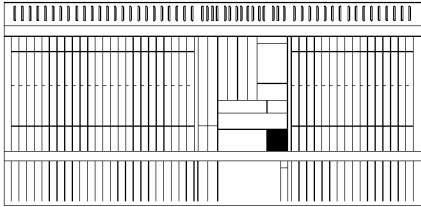

## Scene Control

The Series Two benefits from an intuitive automation system that allows the engineer to store and recall up to 128 different 'scenes', comprising console input mutes and MIDI information for the control of external equipment. Each scene may be recalled in sequence, or individually if required. Individual inputs may be set to 'Mute Safe', effectively removing them from the automation system.

In addition to storing scenes, the engineer may set up eight Mute Groups, allowing multiple channels to be muted as required.

Please note that there are several Operating Modes contained within the Series Two operating system. For full details, refer to Appendix A.

### TIP:

*To those users who are unfamiliar with automation, it is easier to consider a Mute Group as a logical collection of inputs (eg all vocal microphones) that may need to be muted quickly when not in use, and to use the Scene memories to pre-set the console for various key points in the show (such as the beginning of each song).*

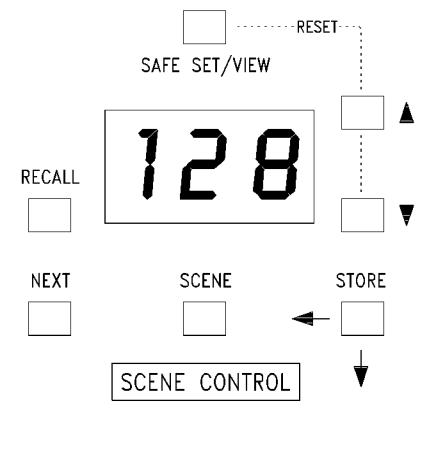

## Connections (Rear Panel)

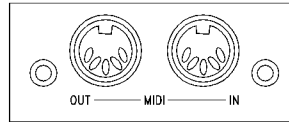
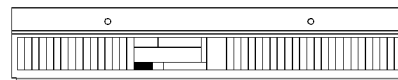

Two MIDI-standard 5-pin DIN sockets are provided, labelled IN and OUT. The Series Two can be connected to other MIDI equipment so that the engineer may use its Scene Control facilities to control outboard processing equipment, playback devices, etc.

The Series Two can accept MIDI Program Changes and Note On/Note Off messages via the IN connector. The OUT connector is used to transmit Program Change messages whenever a Mute Scene is recalled, as well as Note On/Note Off messages that correspond to individual mutes being activated manually.

## Storing a Mute Scene

Firstly, switch on the MUTE buttons of the Mono Inputs, Stereo Inputs and Stereo Returns that you require to be muted; then use the ▲ or ▼ buttons to the right of the three-character display to select the memory you wish to use (1 to 128). Press and hold the STORE button then press the SCENE button. This will store the status of the console in the memory indicated by the 3-character display. You will see '57' appear briefly as the Mute Scene is stored.

## Display

The three-digit LED display shows the scene number, numbered from 1 to 128. If the display is flashing, the number shown has been selected by the ▲/▼ buttons and does not represent the current status of the console.

## Returning the Display to the Last Recalled Mute Scene

This is simply achieved by pressing the SCENE button (without pressing STORE). The flashing 3-character display will change to show the last recalled Mute Scene and will cease to flash.

## Recalling a Mute Scene

This can be done in one of three ways;

- 1 The engineer can recall the next consecutive Mute Scene by using the NEXT button,
- 2 An out-of-sequence Mute Scene is recalled by using the ▲ or ▼ keys to scroll to the correct scene number, followed by the RECALL button,
- 3 A MIDI Program Change can be sent from an external controller to recall the Mute Scene.

Only one Mute Scene may be recalled at any one time.

*TIP:*

*Though the Series Two uses Mute Scene numbers 1-128, these correspond to MIDI program change numbers 0-127. Remember to offset the Program Change by -1 to access the correct scene.*

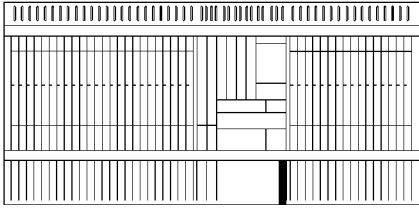

## Mute Groups

The Series Two provides the engineer with eight Mute Groups (MUTE 1 to MUTE 8), which are activated by the illuminated buttons adjacent to the MONO master fader.

## Storing a Mute Group

Firstly, switch on the MUTE buttons of the Mono Inputs, Stereo Inputs and Stereo Returns that you require to be muted.

Press and hold the STORE button then press the relevant Mute Group button (MUTE 1 to MUTE 8).

## Activating a Mute Group

Mute Groups can be activated at any time, and normally override the Mute Scene settings. Simply press the Mute Group button (MUTE 1 to MUTE 8). The associated LED will illuminate.

*TIP:*

*Unlike Mute Scenes, more than one Mute Group may be active at any time. Arranging the input mutes into logical groups of sources will mean that it is easy for the engineer to mute any unnecessary signals by adding two or more Mute Groups.*

## SAFE SET/VIEW Button

Each channel may be set to 'Mute Safe' by pressing its MUTE button while the central SAFE SET/VIEW button is held down. In this way, individual channels may be isolated from the Scene Control system; even if they are programmed to mute in a given scene, they will remain under the engineer's control. Simply pressing the SAFE SET/VIEW button will illuminate the MUTE LED of any channel that is currently set to 'Mute Safe'.

*TIP:*

*If you are using one or more input channels for effects returns, it is advisable to set these to 'Mute Safe' - otherwise a reverb effect may be cut short when a new scene is recalled and the return itself is muted. For this reason, the Stereo inputs 1 & 2 and the four stereo returns are set to mute safe as factory default.*

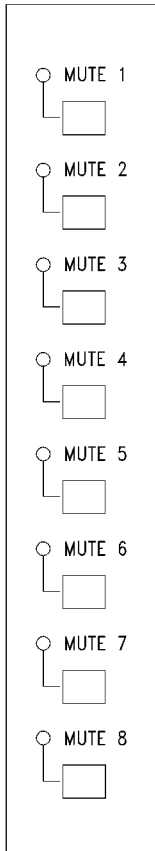

## Using the Series Two to Control External Equipment

Each time a MUTE button is pressed, a single MIDI message is sent. This may be Note On or Note Off, depending on the status of the MUTE switch and the setup of the Operating Modes (see Appendix A). The message may be used to start or stop samplers (for effects playback) or to trigger other events that are relevant to the channel. Please refer to Appendix A for more details.

Every Mute Scene also has an associated MIDI Program Change message, which is transmitted every time the Mutes Scene is recalled. This is extremely useful in controlling outboard effects processors (recalling various preset effects as part of a cue) or for triggering playback, lighting cues or any MIDI-controlled events.

It is also possible to use the Series TWO's scene control system purely as a remote effects program controller, without recalling any mute scenes. This is done by selecting operating mode 7 (see Appendix A for details).

## Using External Equipment to Control the Series Two

Mutes can be externally controlled either by sending a MIDI Program Change to the Series Two (to recall the associated Mute Scene), or by sending a Note On or Note Off message to change the state of an individual input mute. For a list of Note numbers and their corresponding input mutes, Program Change numbers and MIDI channel information, please refer to Appendix A.

Please refer to Appendix A for details on Operating Modes available as part of the Series Two operating system.





**Series TWO**

**5**

# **Appendices**

# Appendix A: Scene Control Advanced Information

## Operating Modes

The Series Two may be set up by the user to optimise its Scene Control system for a particular application. The user has 8 options as shown below, any of which may be set by the engineer. The factory-set default for each of the Operating Modes is off.

<u>Mode</u>	<u>Function</u>	<u>Description</u>
1	MIDI Receive Off	Stops the console responding to external messages (either Prog Change or Notes)
2	MIDI Transmit Off	Stops the console sending any MIDI messages
3	Program Change Transmit Off	Allows Note On/Note Off to be transmitted but not Prog Changes
4	Mutes as MIDI Note On/Off	See 'Note On/Note Off' below - this selects Sampler Mode when active
5	Scenes override active Mute Groups	Allows a recalled Scene to un-mute channels that were muted as part of a Mute Group
6	Scenes override manual MUTE presses	Allows a recalled Scene to un-mute channels that were muted manually by the engineer
7	Scene recall transmits Program Change only	Recalling a scene has no effect on console mutes; this turns the Scene control system into a controller for external devices only
8	All Automation Off	

## Setting an Operating Mode

The engineer can activate any of the above modes by holding down the corresponding Mute Master button (MUTE 1 to MUTE 8) while the console powers up, or while a Processor reset is performed (see Resetting the Console, Page A4). The Mute Master LEDs show which modes are active during power-up.

## MUTE/MIDI Note Operation

The default factory setup allows channel Mutes to respond to MIDI Note On messages, with the Velocity determining whether the Mute is on or off. This is known as **Sequencer Mode**, as it resembles that way in which a MIDI sequencer would be used to control the Series Two. A velocity value of '0' is interpreted as 'Mute On'; any other value is seen as 'Mute Off'.

For transmission, pressing a MUTE button to activate the Mute will transmit a Note On message with a velocity of 127 ('7F'); un-muting the channel will send a Note On message with a velocity value of 0 ('00').

Message format:            <Note On> <Console Channel> <Velocity>  
For 'Mute On'                <Note On> <Console Channel> <127>  
For 'Mute Off'                <Note On> <Console Channel> <0>

Please refer to 'Console Channel/MIDI Note Conversion' below for details of console channel numbers.

The Series Two can be user-set to work in **Sampler Mode**, where Note Off represents a Mute being activated and Note On is equivalent to the channel being un-muted. If used with a sampler, this allows the engineer to trigger samples by simply un-muting the relevant channel - a useful method of integrating effects playback into the console itself. Velocity is set to 127 ('7F') in either case.

MIDI Message format: <Note On/Note Off> <Console Channel>  
<Velocity>

For 'Mute On' <Note Off> <Console Channel> <127>

For 'Mute Off' <Note On> <Console Channel> <127>

### **Console Channel/MIDI Note Conversion**

The following table shows how Channel numbers are mapped to MIDI Note numbers:

<b><u>Console Channel</u></b>	<b><u>MIDI Note Number (Hex)</u></b>	<b><u>MIDI Note Number (Decimal)</u></b>
Mono Input 1	00	0
Mono Input 2	01	1
Mono Input 3	02	2
Mono Input 4	03	3
Mono Input 24	17	23
Mono Input 32	1F	31
Mono Input 40	27	39
Stereo Input 1	28	40
Stereo Input 2	29	41
Stereo Return 1	2A	42
Stereo Return 2	2B	43
Stereo Return 3	2C	44
Stereo Return 4	2D	45

### **Program Change Messages**

Unless Operating Modes are set to prevent MIDI transmission, recalling a Scene will send a Program Change message. The format is as follows:

<Prog Change> <Prog Number>

Transmission is on MIDI Channel 16. Program Change numbers are offset by -1 when compared with their associated Scene; Scenes 1 to 128 correspond to Program Changes 0 to 127. The same is true when receiving MIDI Program Changes.

### **Mute Groups and MIDI**

Mute Groups are NOT connected with any MIDI messages.

## **Backing Up and Restoring a Show**

The Series Two will allow a show (multiple Scenes and Mute Group allocations) to be saved off-line by using a MIDI System Exclusive 'Dump Out'. Similarly, a show can be loaded into the console by sending it back a Sys Ex dump.

The Dump Out is initiated by simultaneously pressing the ▲, ▼ and STORE keys. During the Dump Out sequence the normal console operation is suspended (including manual Mute On/Off) and the 3-character display will display 'dO'. During Sys Ex reception, the display will display 'dI'. The Sys Ex dump is best stored using Sys Ex librarian software, recorded on a sequencer track, or saved to a MIDI data file.

## **Resetting the Console**

In the unlikely event of a software failure, the processor can be reset without powering down the console by simultaneously holding down the SAFE SET/VIEW, UP and DOWN keys. This **Processor Reset** will restart the processor, but will not clear either Mute Groups or Scene memories. The Scene Control display and functions will return to their pre-reset states.

If the engineer wishes to clear the console's memories, it is possible to perform a **Hard Reset**, by pressing and holding the NEXT, SCENE and STORE buttons during power-up. This will restore the factory default settings, which are shown below:

<b><u>Function</u></b>	<b><u>Default State</u></b>
Mute Groups	All empty, all deselected
Scenes	All Mutes Off, displayed Scene = 1
Safes	All channels not Safe, except Stereo inputs 1&2 and stereo returns 1-4.
Mutes	All Mute Off
Operating Modes	All Off

## **Software Version**

The three-character display will show the software version number for a couple of seconds during power-up. A display showing '\_ 10' refers to Version 1.0.

# Appendix B: Cable Wiring Diagrams

## INPUTS

Balanced Mic  
XLR

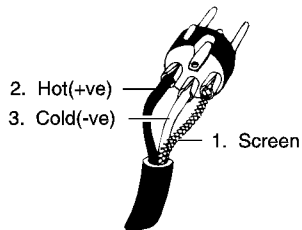

Unbalanced Mic  
XLR

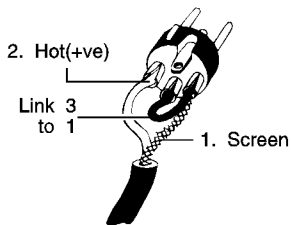

Line Inputs

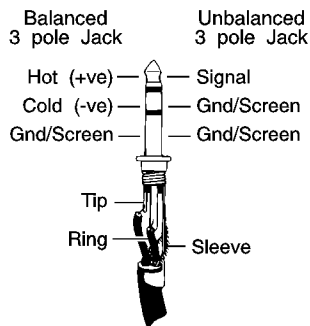

Inserts

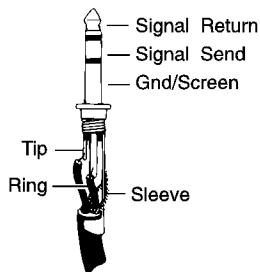

Replay In/Rec Out

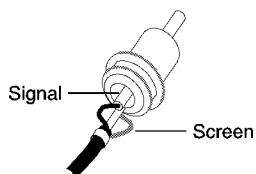

## OUTPUTS

Mix Outputs

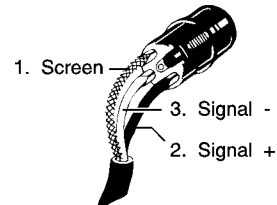

Mix & Group Inserts

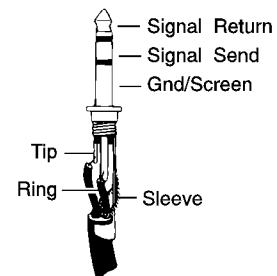

Aux Outputs  
Group Outputs  
Direct Outputs  
Matrix Outputs

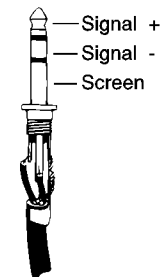

Headphones

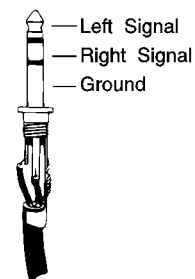

## Appendix C: Technical Specifications

Performance Data	
Frequency Response	XLR input to any output: +0/-0.5dB, 20Hz-20kHz
T.H.D. and Noise	Measured at +4dBu output, 1kHz XLR in to Mix Output @ +20dBu: <0.0065%
Mic Input E.I.N	22Hz-22kHz bandwidth, unweighted, (200Ω source): <-127dBu
Residual Noise	Mix Output; no inputs routed, Mix fader@0dB: -88dBu
Bus Noise	Mix Output; 40channels routed, input faders @ -∞, Mix fader 0dB: -79dBu
	Group Output; 40 channels routed, input faders @ -∞, Mix fader 0dB: -80dBu
Crosstalk	1 kHz
	Input channel muting: 90dB
	Input fader cutoff: 90dB

Mono Input EQ and Filter		
High Pass	Freq	40-400Hz
	Slope	12dB/octave
HF	Freq	12kHz
	Gain	+/- 15dB
HMID	Freq	550Hz-1.3kHz
	Gain	+/- 15dB
	Q	1.3
LMID	Freq	80Hz -1.9kHz
	Gain	+/- 15dB
	Q	1.3
LF	Freq	60Hz
	Gain	+/- 15dB

Connections		
Connection	Impedance	Level
Low Impedance Input (XLR)	2kΩ	-60dBu to -15dBu /-40dBu to +5dBu (+27dBu max)
High Impedance Input (jack)	> 10kΩ	As low impedance input.
Insert (jack)	Unbalanced send/return 75Ω/10kΩ	0dBu (+22dBu max)
Direct Out (jack)	75Ω Impedance balanced	0dBu (+22dBu max)
Stereo Input/Return (jack)	> 10kΩ balanced	+4dBu (+26dBu max)
Replay Input (RCA phono)	> 10kΩ unbalanced	-10dBV (+14dBu max)
Record Output (RCA phono)	75Ω unbalanced	-10dBV (+22dBu max)
Group Insert (jack)	Unbalanced send/return 75Ω/10kΩ	0dBu (+22dBu max)
Group Output (jack)	75Ω Impedance balanced	+4dBu (+22dBu max)
Aux Output (jack)	75Ω Impedance balanced	+4dBu (+22dBu max)
Matrix Output (jack)	75Ω Impedance balanced	+4dBu (+22dBu max)
L/R/Mono Insert (jack)	Unbalanced send/return 75Ω/10kΩ	0dBu (+22dBu max)
L/R/Mono Output (XLR)	75Ω balanced	+4dBu (+26dBu max)

# Appendix D: Input Equaliser Curves

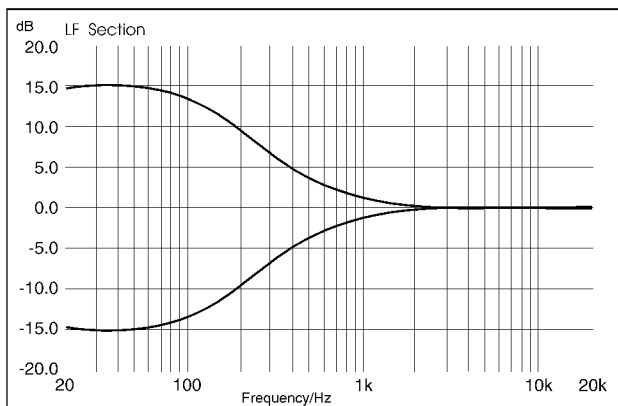
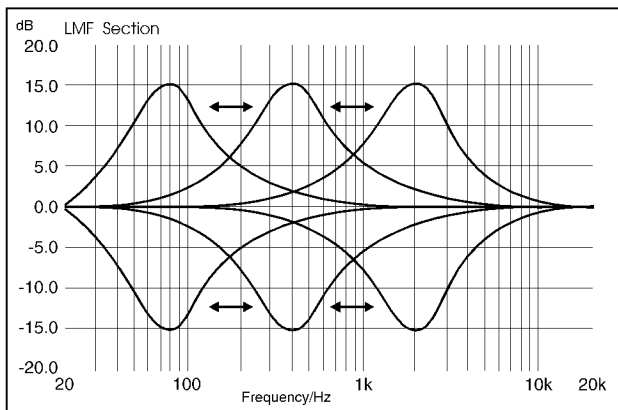
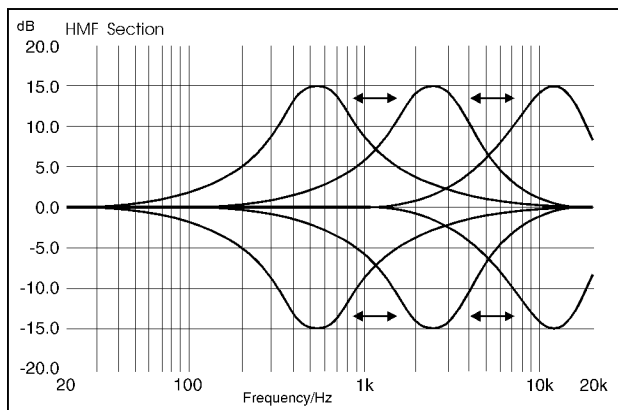
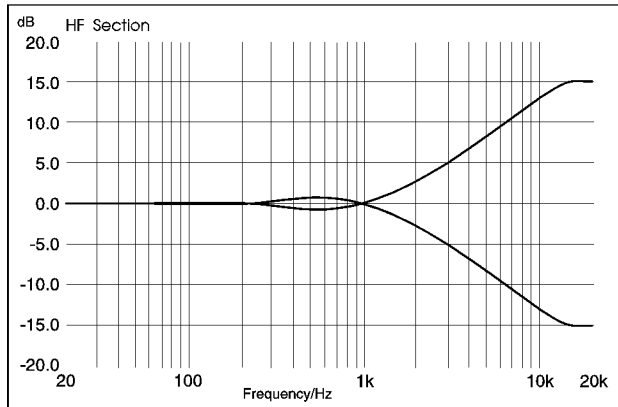

## Appendix E: Troubleshooting Guide

Correct installation and operation of your Series Two console should result in many years of trouble-free mixing; however, the console is part of a larger and sometimes complex system, which may occasionally present the user with a problem. This section is a guide to the most common system difficulties, and should give the user a few hints on how to avoid their repetition.

### An input sounds distorted

Firstly, check the input meter. If the level is constantly lighting up the top LEDs ('I2' and 'I6/PK'), then the input level is too high. Turn down the SENS control until the top LEDs stop illuminating. If the SENS control is already fully counter-clockwise, press the -20 switch to reduce the input gain, and adjust the SENS control again.

### An output sounds distorted

Subgroup or Left/Right/Mono master outputs are permanently displayed on dedicated meters, so excessive level should be obvious. In the case of an Aux or Matrix output, press the AFL button for that output to check the level on the PFL/AFL meter. If the top LED on the meter ('I6') is constantly illuminated, reduce the output level control.

### An input is 'noisy'

Increasing the gain of a low-level input also increases the noise level of the signal; this may be heard as a hiss or even buzz. The console itself is engineered to add no appreciable noise to the signal, so try to adjust the level at the source first (for example, at the guitar amplifier or keyboard output) before adjusting the level at the console. It may be worth checking the cable that connects the source to the input; if one signal core of a balanced pair is broken, the signal level will be reduced and noisy.

### Even with the SENS control fully clockwise, there is not enough signal level

This problem is similar to the noisy input; if a source is too quiet, the best way to make up the level is at the source. Check, though, that the -20 switch is not pressed, as this will reduce the maximum gain that you can apply to the signal.

### The input signal does not reach the subgroups or master outputs

Apart from checking that the subgroup/master routing switches are set correctly (and that the channel's MUTE is not active), you should check whether the input has an external processor connected to its INSERT point. Disconnect the jack if this is the case; if the signal returns, the processor or insert cable is at fault.

### When the system is connected, 'hum' is heard

This can be a complex problem to solve, as hum can be picked up almost anywhere in the system. To isolate the probable cause, mute all the input channels one-by-one and listen to the system. If the hum disappears, the problem is in the source, the input section or the outboard equipment connected to it, in which case each INSERT point should be checked (by removing the jack). If not, turn down the subgroup faders and aux master controls one by one. If the hum persists, remove any jacks from the INSERT points of the Left/Right/Mono outputs, to check whether outboard processing equipment is the cause. If not, pull down the Left/Right/Master faders. If the hum is still present, check the system 'downstream' of the console, especially the mains power connections - often the problem is caused by plugging the console into a different supply from the rest of the system.



DO NOT AT ANYTIME REMOVE MAINS EARTH CONNECTIONS TO GET RID OF UNWANTED HUM.

**When the system is connected, radio noise is heard**.....

This is usually the result of an unbalanced connection somewhere in the system. Repeat the sequence above, and when the input or output is identified, swap the connecting cables with a working input or output.

**The input fader is at '+10', but there is still not enough level**.....

This is the result of insufficient gain at the input amplifier. Decrease the fader level to '0', then adjust the SENS control so that the input meter shows a normal level. If this makes the input's noise audible, adjust the level at the source (see above). If the input signal is known to be good, but the meter level is low, check that any outboard equipment connected to the INSERT point is not responsible for reducing the signal level.

**With the subgroup and master faders at '0', the output is too loud**.....

This is the result of overloading the subgroup mix busses by having the input levels too high. A common reason is that individual fader levels are often increased to boost solos, but are not necessarily reduced by the same amount. This will mean that input faders are approaching the top of their travel (+10dB), requiring the output faders to be pulled back. In this case, reduce the level of every input fader - remembering that this will also affect any post-fade aux sends. If the input faders are more-or-less at the '0' mark, reduce the SENS level of each channel by the same amount to preserve the balance of the mix.

**Inputs are routed correctly, but no signal is present at the Left/Right outputs.**.....

Check that the SOLO-IN-PLACE LEDs are not lit - if the ACTIVE LED is illuminated, there is an active SOLO button somewhere on the console that is overriding the normal Left/Right outputs. (This should be obvious due to the illumination of most of the console's mute switches).

**A stereo source sounds unnaturally 'thin'**.....

Lack of low frequencies may be a result of one half of the stereo signal being 'phase-inverted' - either by a mis-wired cable, an incorrectly set-up source or by the Ø button on the Mono Input. If the stereo source is connected to two Mono Inputs, press the Ø button of one channel and listen for an improvement in signal quality (this is best done with a full range source like modern music). If the input is connected to a Stereo Input, re-connect to two spare Mono Inputs and repeat the check.

**Even with no solo's pressed, there is still a signal at the Monitor outputs**.....

This is a result of selecting MONO, STEREO or REPLAY as the monitor default feed. Select an unused feed (usually REPLAY) or deselect all three source buttons to mute the Monitor output when no SOLO, PFL or AFL buttons are pressed.



**Series TWO**

**6**

# **Circuit Diagrams & PCB Layouts**

# Contents

---

ED4019 Iss 6/SC4019 Iss 6 . . . . .	Mic Amp
ED4020 Iss 6/SC4020 Iss 6 . . . . .	Master
ED4021 Iss 3/SC4021 Iss 3 . . . . .	Blyth Live
ED4022 Iss 6/SC4022 Iss 6 . . . . .	Meter Board
ED4023 Iss 3/SC4023 Iss 3 . . . . .	Blyth Live
ED4024 Iss 2/SC4024 Iss 2 . . . . .	Rearconn Board
ED4025 Iss 4/SC4025 Iss 4 . . . . .	Rearcon & Midi
ED4026 Iss 4/SC4026 Iss 4 . . . . .	Output Fader PCB
ED4027 Iss 6/SC4027 Iss 6 . . . . .	O/P Meter
ED4028 Iss 1/SC4028 Iss 1 . . . . .	Moving Fader PCB
ED4041 Iss 3/SC4041 Iss 3 . . . . .	PSU Distribution PCB
ED3657 Iss 3/SC3657 Iss 3 . . . . .	DCP200 PSU

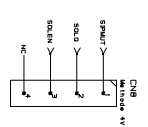
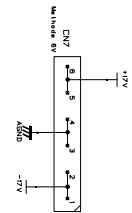
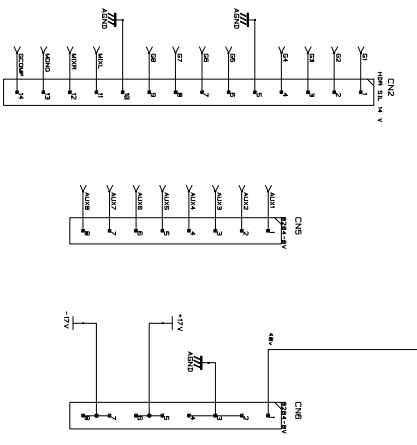
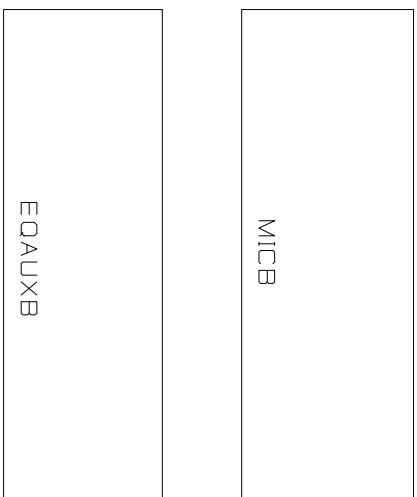
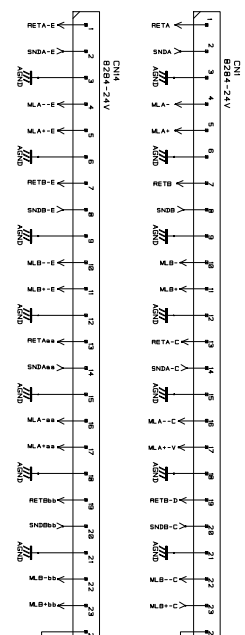
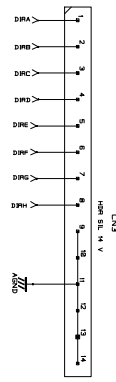
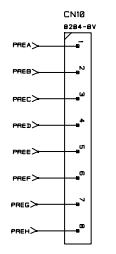

SOUND-CRAFT OWNS THE COPYRIGHT OF THIS DRAWING WHICH IS NOT TO BE REPRODUCED OR TRANSMITTED IN ANY FORM OR BY ANY MEANS WITHOUT WRITTEN PERMISSION.

- NOTES
- (1) ONLY CHANNELS A AND B (1 AND 2) ARE SHOWN.
  - (2) CHANNELS C TO H (3 TO 8) ARE SAME AND TO BE REPEATED.
  - (3) TOTAL CHANNELS ARE A TO H (8) ON PCB

DRN: GHB

DATE
------

SOUND-CRAFT INDUSTRIES LTD.  
HARMANT HOUSE  
CRANBORNE ROAD.  
POTTERS BAR.  
MIDDLESEX.  
TEL: 01753 650092  
FAX: 01753 650482

TITLE

SERIES TWO  
MIC AMP

DRG NO. ED4019

SHEET 1 OF 5





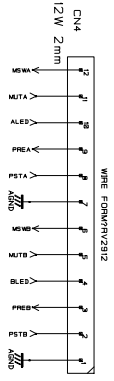
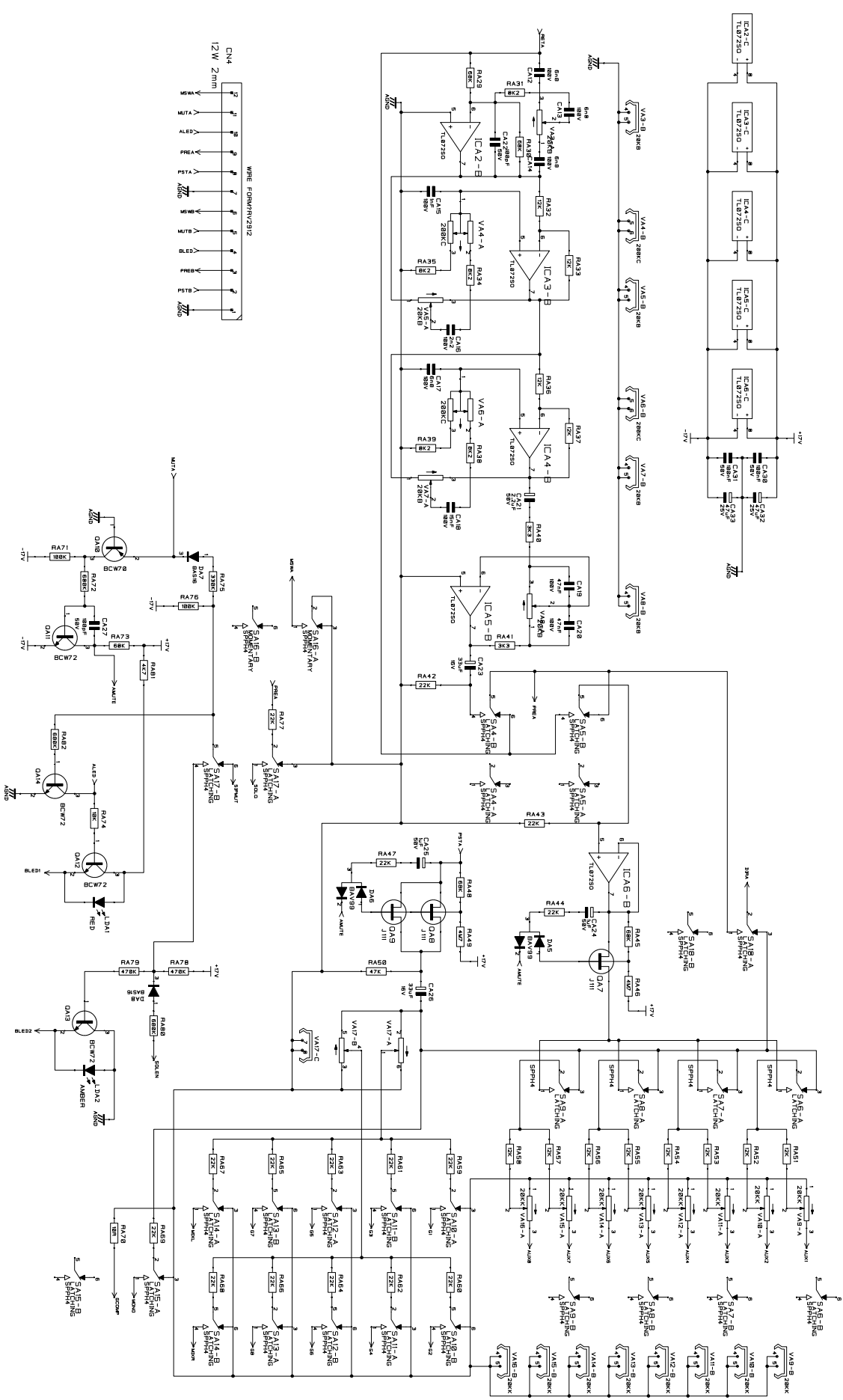

- NOTES
- (1) ONLY CHANNELS A AND B (1 AND 2) ARE SHOWN.
  - (2) CHANNELS C TO H (3 TO 8) ARE SAME AND TO BE REPEATED.
  - (3) TOTAL CHANNELS ARE A TO H (8) ON PCB

SOUNDRAFT OWNS THE COPYRIGHT OF THIS DRAWING WHICH IS NOT TO BE A THIRD PARTY WITHOUT WRITTEN PERMISSION.

DRN:	GHB	SOUNDRAFT INDUSTRIES LTD. HARMANT HOUSE, CRANBORNE ROAD, POTTERS BAR, IN. HERTS. SG9 6SL FAX: 01787 550082	TITLE SERIES TWO MIC AMP
DATE			
DRG NO.	ED4019		SHT. 1 OF 5



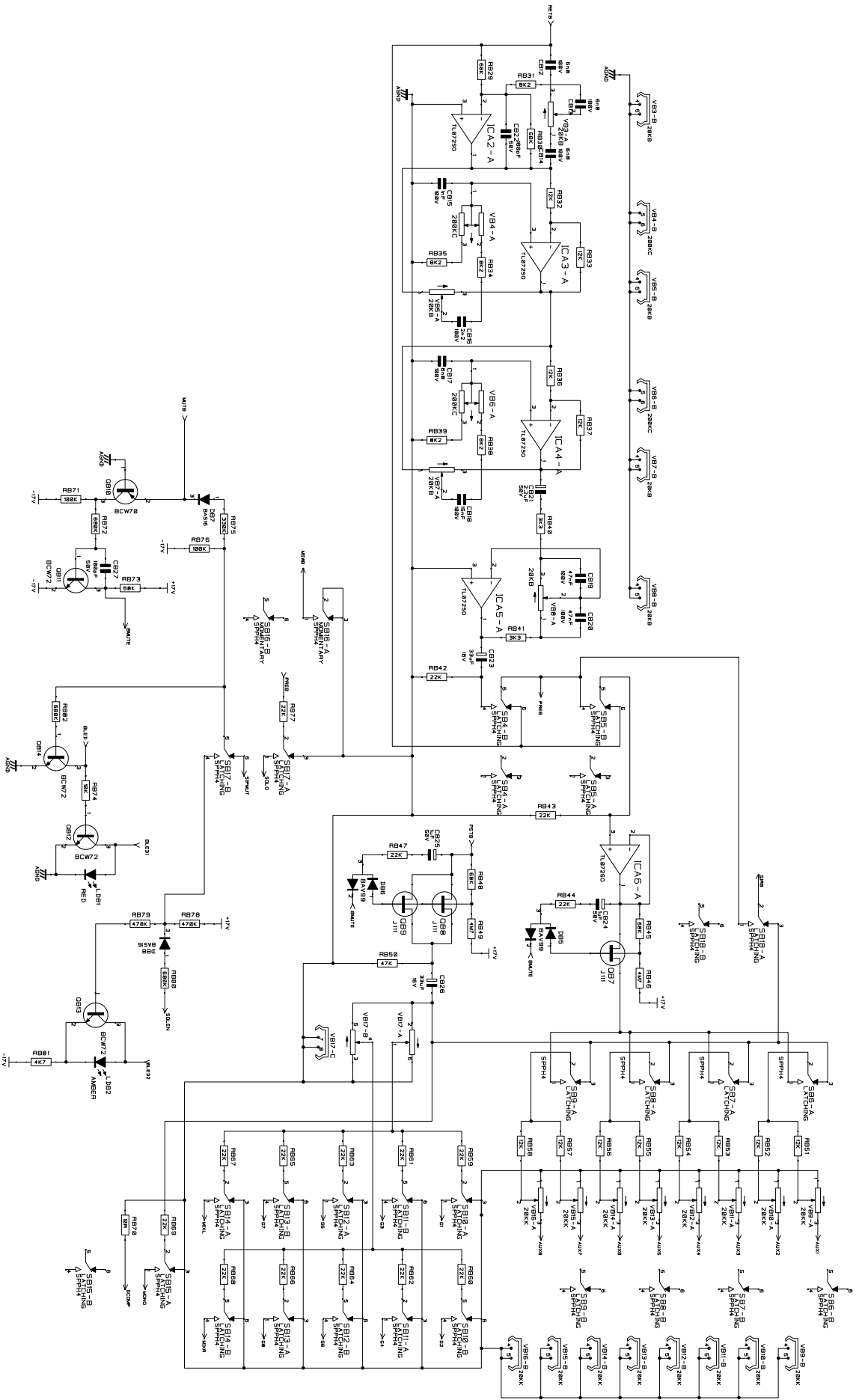

- NOTES
- (1) ONLY CHANNELS A AND B (1 AND 2) ARE SHOWN.
  - (2) CHANNELS C TO H (3 TO 8) ARE SAME AND TO BE REPEATED.
  - (3) TOTAL CHANNELS ARE A TO H (8) ON PCB

SOUNDCRAFT OWNS THE COPYRIGHT OF THIS DRAWING WHICH IS NOT TO BE REPRODUCED OR TRANSMITTED IN ANY FORM OR BY ANY MEANS WITHOUT WRITTEN PERMISSION.

DRN:	GHB	SOUNDCRAFT INDUSTRIES LTD.	TITLE	SERIES TWO MIC AMP
DATE		HARMAN INT. HOUSE, CRANBORNE ROAD, POTTERS BAR, IN. HERTS. EN9 5JQ FAX: 01767 560482	DRG. NO.	ED4019
SHT. 5 OF 5				

SHEET 1

STEREO 1 & 2  
MALE  
DIP34+OP-285A

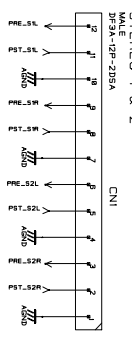

GROUPS 1-4  
MALE  
DIP34+OP-285A

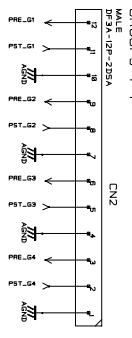

GROUPS 5-8  
MALE  
DIP34+OP-285A

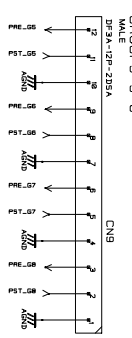

LR MIX & MONO  
MALE  
DIP34+OP-285A

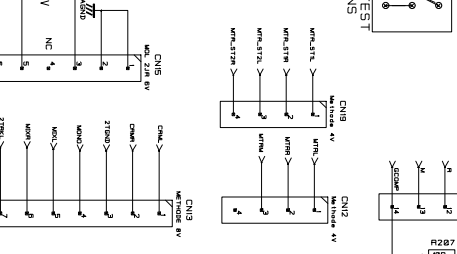
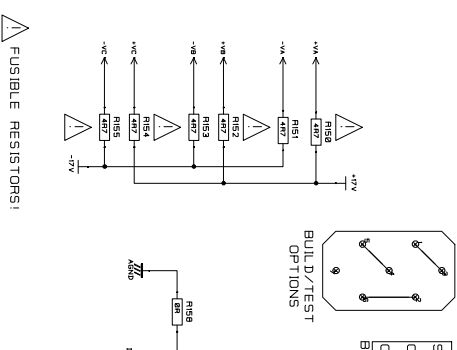
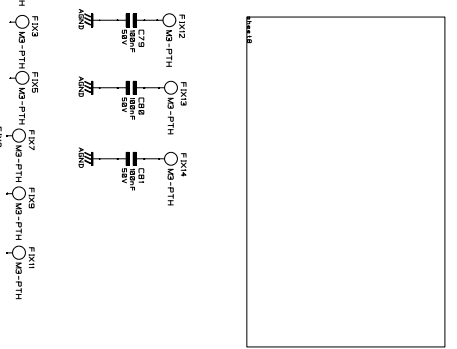
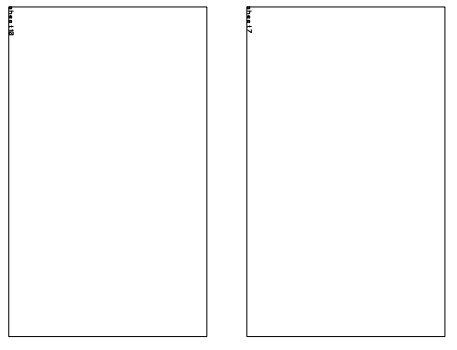
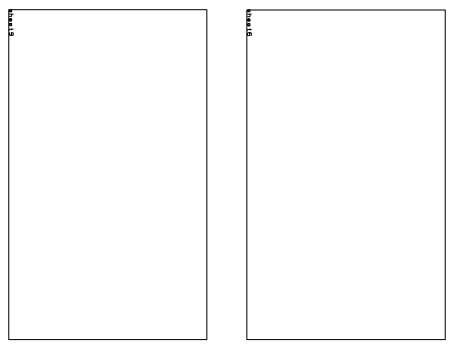
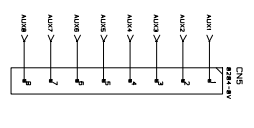
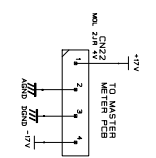
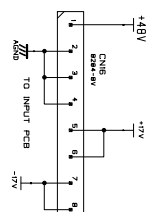
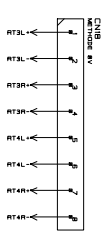
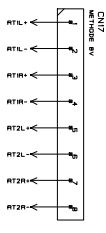
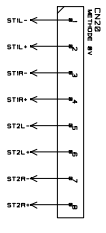
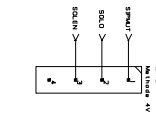
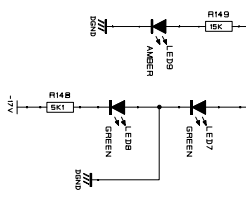
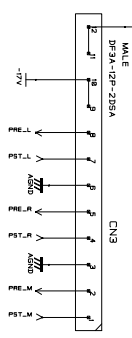

FUSIBLE RESISTORS!

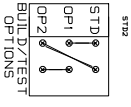
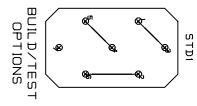
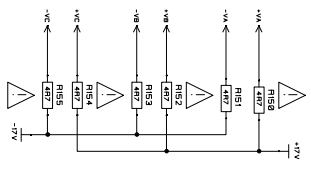

NOTES

SOUNDRAFT OWNS THE COPYRIGHT OF THIS DRAWING WHICH IS NOT TO BE A THIRD PARTY WITHOUT WRITTEN PERMISSION.

DRN: GHB

DATE

TITLE

SOUNDRAFT INDUSTRIES LTD.  
HARMANNIT HOUSE,  
CRANBORNE ROAD,  
POTTERS BAR, IN.  
HERTS, EN9 6JQ  
TEL: 01763 630092  
FAX: 01763 660482

SERIES TWO  
MASTER

DRG. NO. ED4020

INITIAL	ISSUE	DATE
DCB	6:01	01-05-00

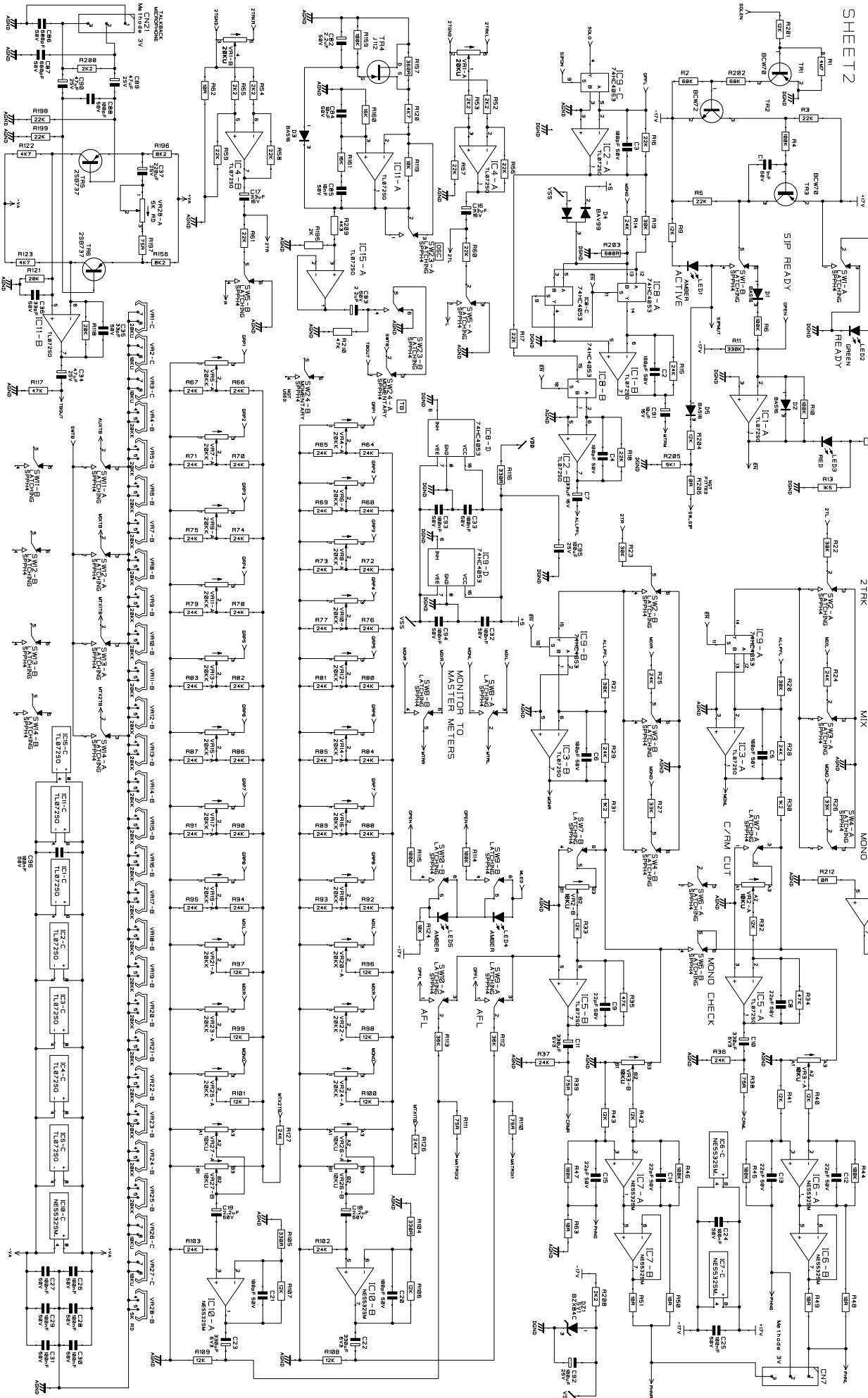

SOUNDRAFT OWNS THE COPYRIGHT OF THIS DRAWING WHICH IS NOT TO BE REPRODUCED OR TRANSMITTED IN ANY FORM OR BY ANY MEANS WITHOUT WRITTEN PERMISSION.

NOTES

DRN.	GH8	TITLE	SOUNDRAFT INDUSTRIES LTD.
DATE			HARMAN INT HOUSE, CRANBORNE ROAD, POTTERS BAR, MIDTLESEX, ENGLAND TEL: 01707 655000 FAX: 01707 650482
			DRG NO. ED40220

IC1-A	74HC483	IC1-B	74HC483	IC1-C	74HC483	IC1-D	74HC483
IC2-A	74HC483	IC2-B	74HC483	IC2-C	74HC483	IC2-D	74HC483
IC3-A	74HC483	IC3-B	74HC483	IC3-C	74HC483	IC3-D	74HC483
IC4-A	74HC483	IC4-B	74HC483	IC4-C	74HC483	IC4-D	74HC483
IC5-A	74HC483	IC5-B	74HC483	IC5-C	74HC483	IC5-D	74HC483
IC6-A	74HC483	IC6-B	74HC483	IC6-C	74HC483	IC6-D	74HC483
IC7-A	74HC483	IC7-B	74HC483	IC7-C	74HC483	IC7-D	74HC483
IC8-A	74HC483	IC8-B	74HC483	IC8-C	74HC483	IC8-D	74HC483
IC9-A	74HC483	IC9-B	74HC483	IC9-C	74HC483	IC9-D	74HC483
IC10-A	74HC483	IC10-B	74HC483	IC10-C	74HC483	IC10-D	74HC483

INITIAL	ISSUE	DATE
DCB	6:01	01-05-00

SHEET 3

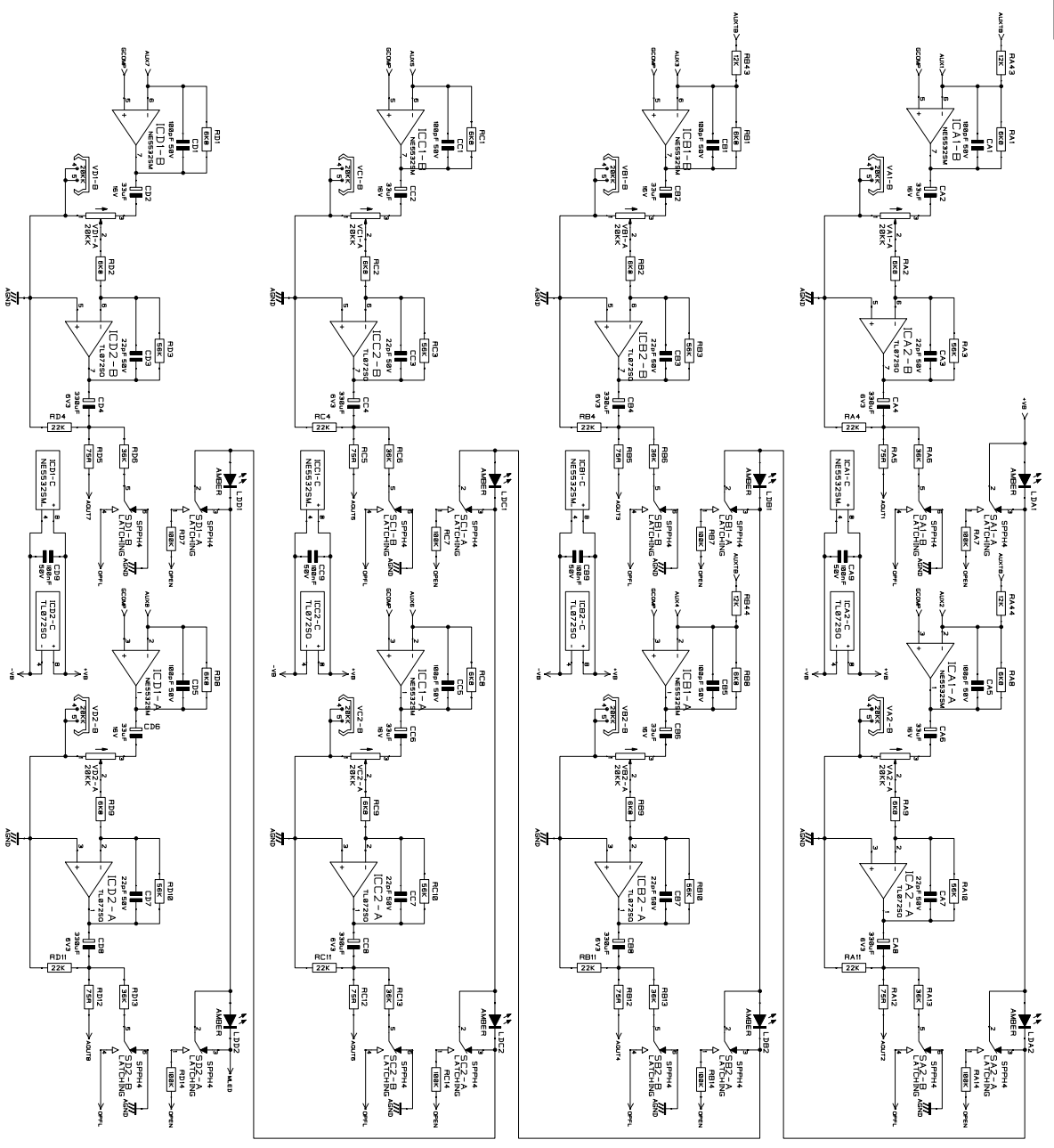

NOTES

SOUNDRAFT OWNS THE COPYRIGHT OF THIS DRAWING WHICH IS NOT TO BE A THIRD PARTY WITHOUT WRITTEN PERMISSION.

DRN: GHB

DATE

SOUNDRAFT INDUSTRIES LTD.  
HARMANN NT HOUSE,  
CRANBORNE ROAD,  
POTTERS BAR, IN.  
HERTS. SG9 6JL  
TEL: 01753 654000  
FAX: 01753 654182

TITLE  
SERIES TWO  
MASTER

DRG NO. ED4020

SHEET 4

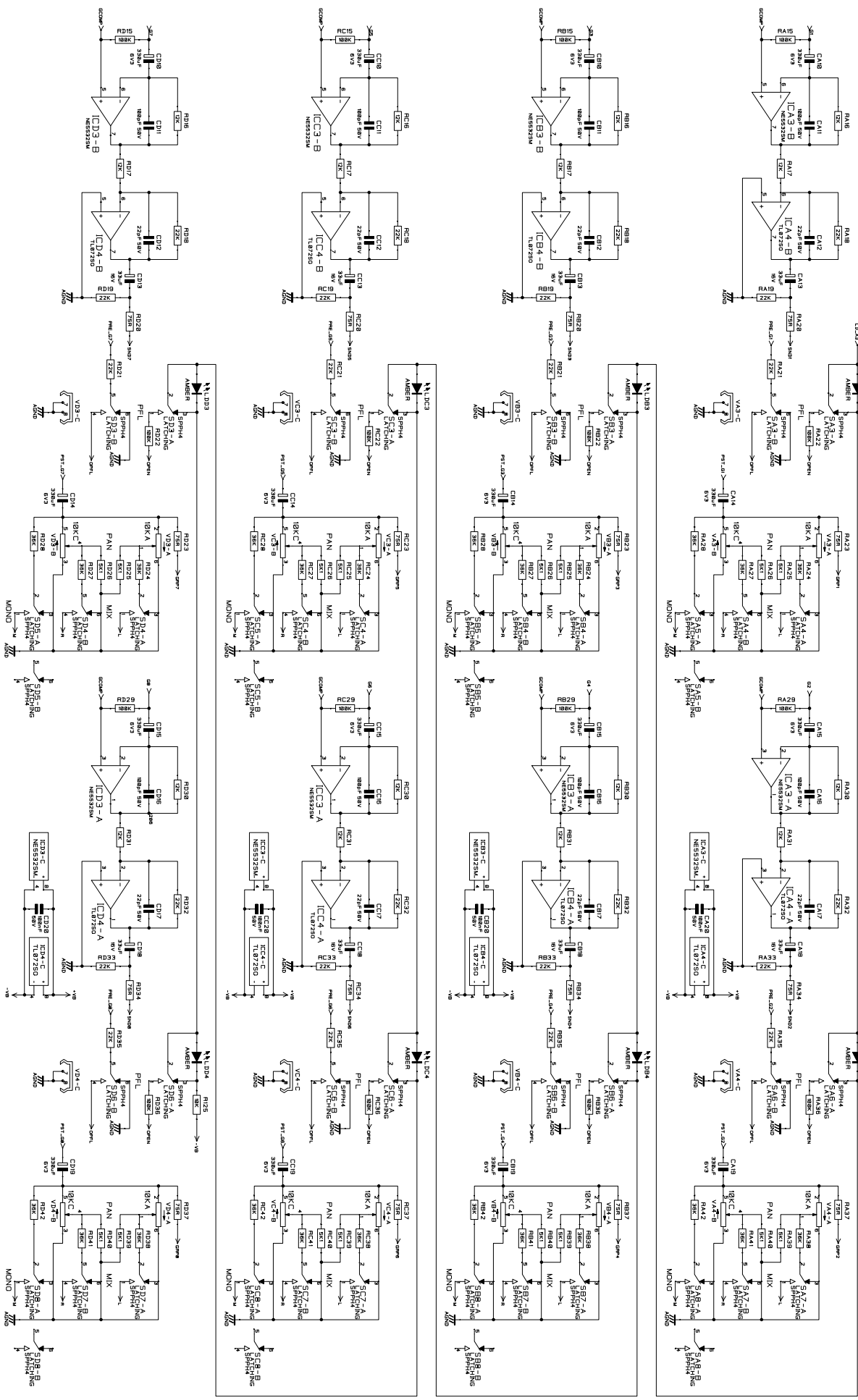

NOTES

SOUNDRAFT OWNS THE COPYRIGHT OF THIS DRAWING WHICH IS NOT TO BE A THIRD PARTY WITHOUT WRITTEN PERMISSION.

DRN. GHB

DATE

TITLE

SOUNDRAFT INDUSTRIES LTD.  
 HARMANN NT HOUSE,  
 CRANBORNE ROAD,  
 POTTERS BAR, N.  
 HERTS. EN9 5JN.  
 TEL: 0438 550099  
 FAX: 01707 550482

DRG. NO. ED4020

INITIAL	ISSUE	DATE
DCB	6:01	01-05-00

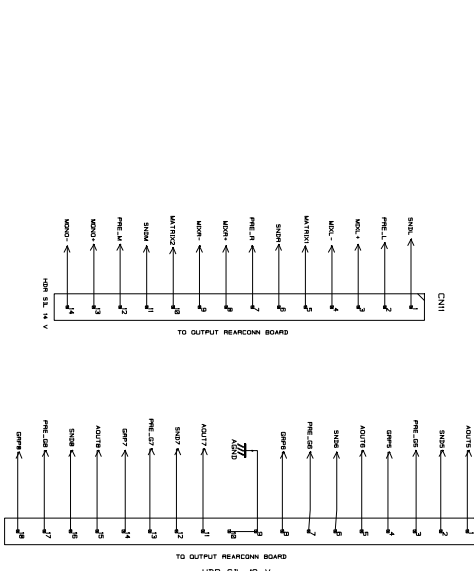
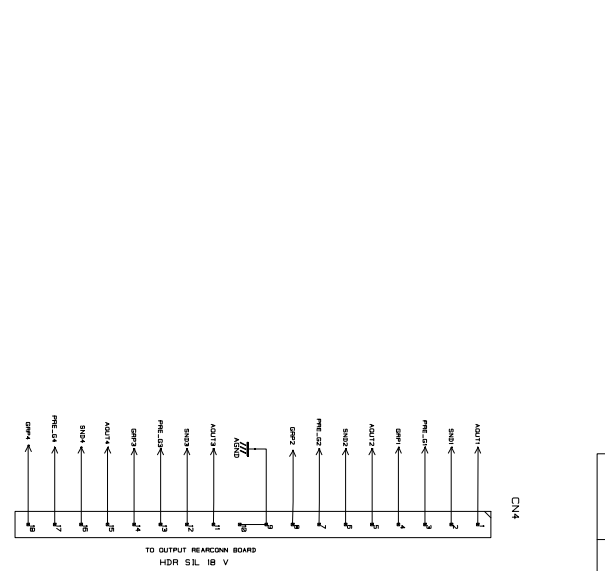
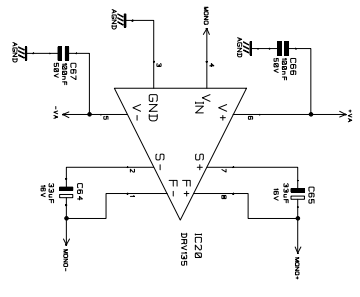
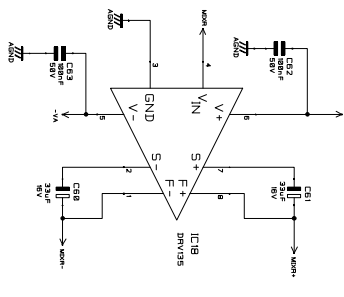
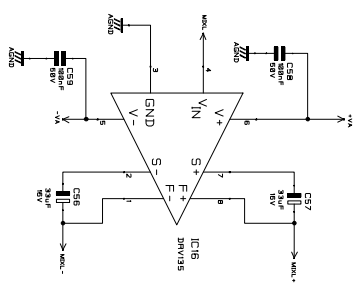
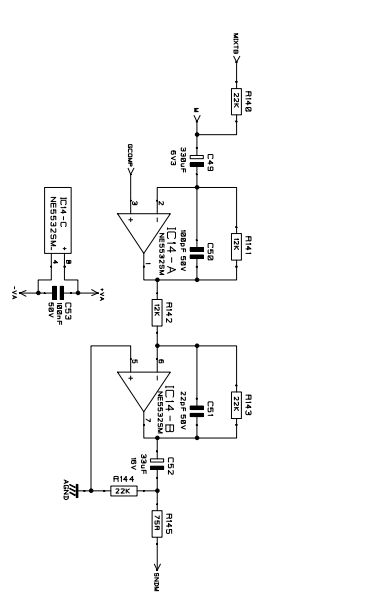
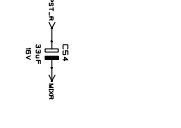
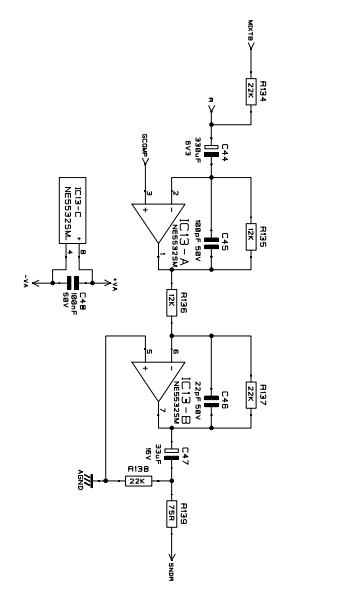
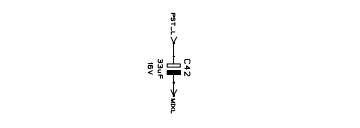
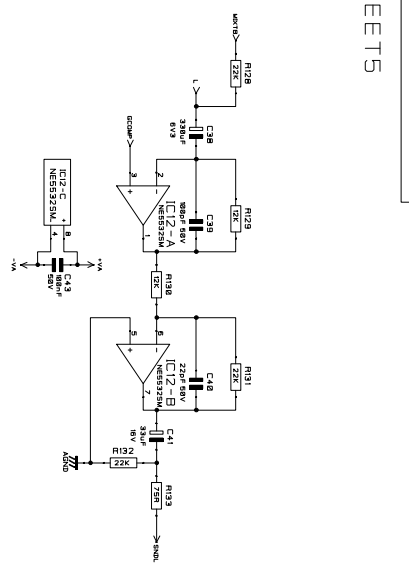

NOTES

SOUNDRAFT OWNS THE COPYRIGHT OF THIS DRAWING WHICH IS NOT TO BE A THIRD PARTY WITHOUT WRITTEN PERMISSION.

DRN. GH8

DATE

SOUNDRAFT INDUSTRIES LTD.  
HARMAN INT. HOUSE,  
CRANBORNE ROAD,  
POTTERS BAR, IN.  
TEL: 01753 631000  
FAX: 01753 650482

TITLE

SERIES TWO  
MASTER

DRG NO. ED40220

INITIAL	ISSUE	DATE
DCB	6:01	01-05-00

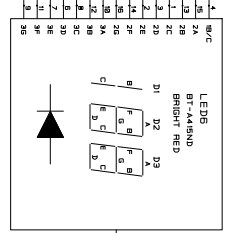
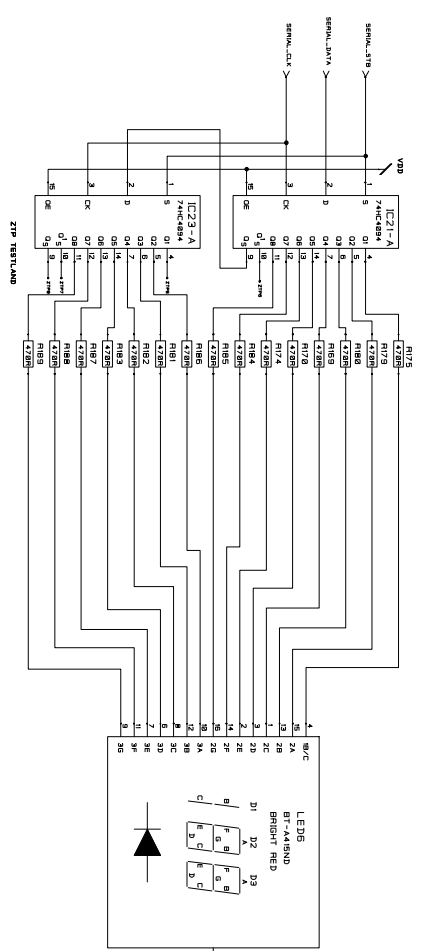
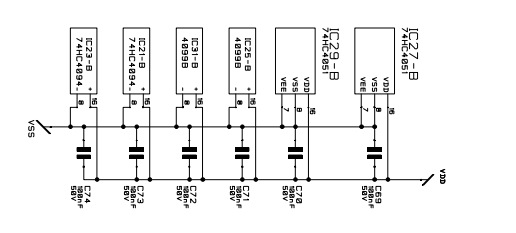
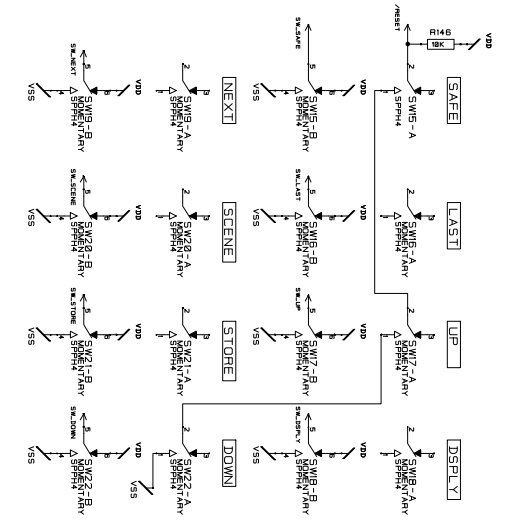
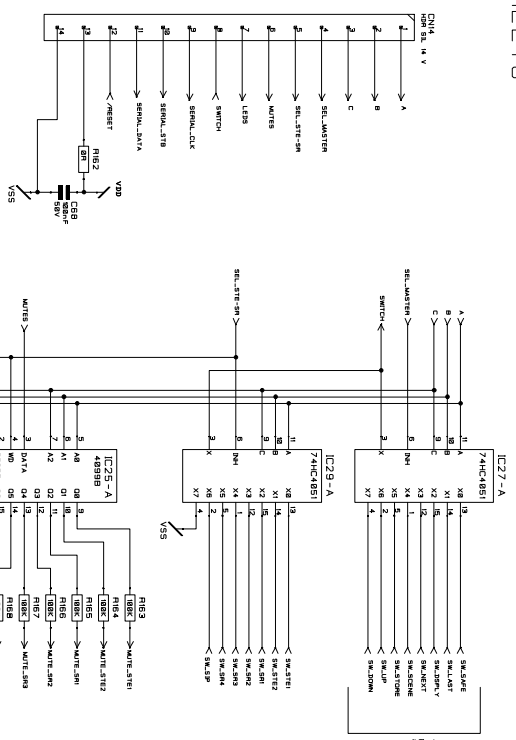

NOTES

SOUNDCRAFT OWNS THE COPYRIGHT OF THIS DRAWING WHICH IS NOT TO BE A THIRD PARTY WITHOUT WRITTEN PERMISSION.

DRN. GHB

DATE

TITLE

SERIES TWO MASTER

DRG. NO. ED40220

SOUNDCRAFT INDUSTRIES LTD.  
HARMAN INT.  
CRANBORNE HOUSE,  
CRANBORNE ROAD,  
POTTERS BAR, IN.  
HERTS. SG9 5JG  
TEL: 01753 650009  
FAX: 01753 650482





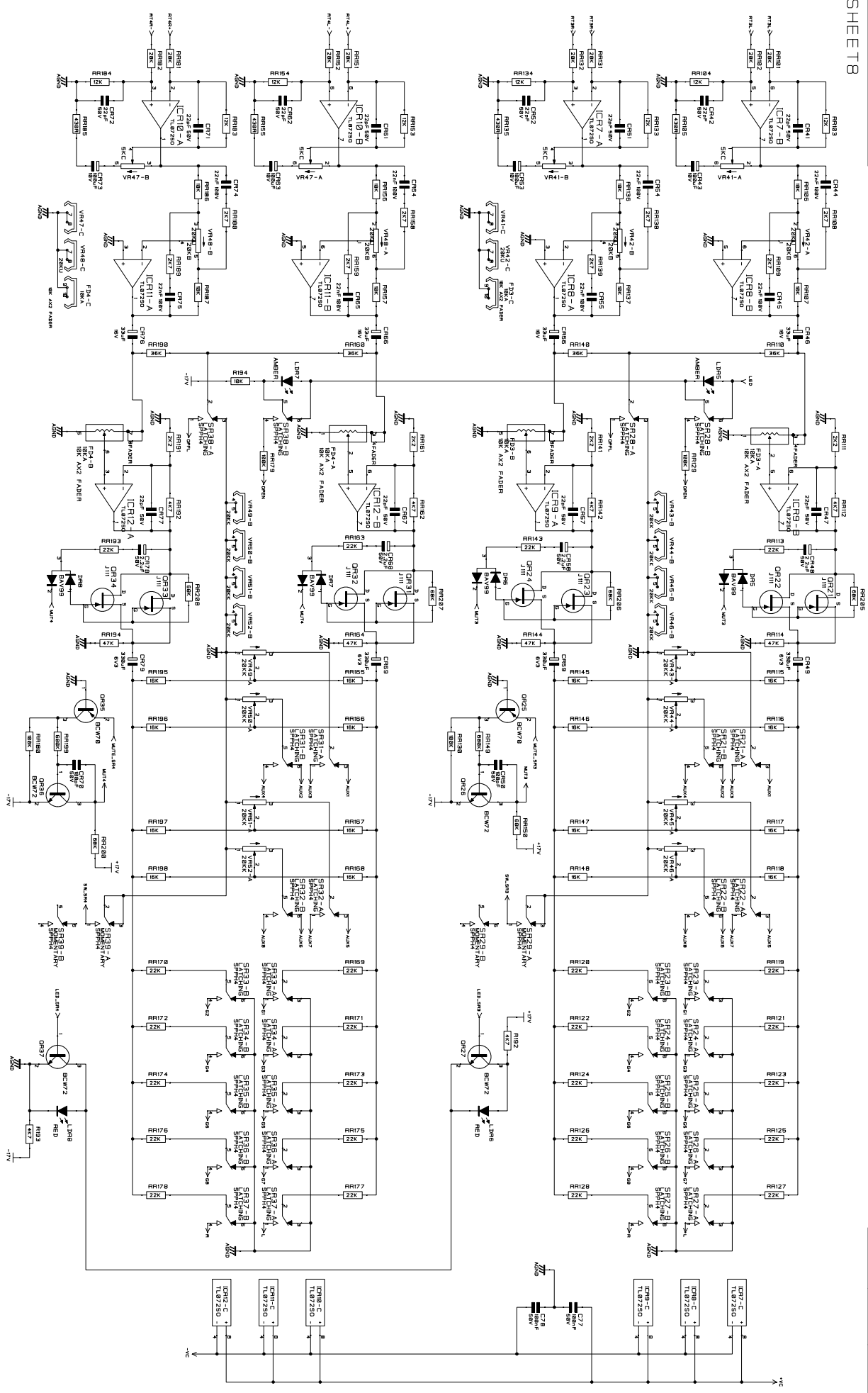

NOTES

SOUNDRAFT OWNS THE COPYRIGHT OF THIS DRAWING WHICH IS NOT TO BE A THIRD PARTY WITHOUT WRITTEN PERMISSION.

DRN. GHB

DATE

SOUNDRAFT INDUSTRIES LTD.  
HARMAN INT. HOUSE.  
CRANBORNE ROAD.  
POTTERS BAR, N.  
HERTS. EN9 6JN  
TEL: 0438 530092  
FAX: 01767 668482

TITLE

SERIES TWO  
MASTER

DRG. NO. ED4020

INITIAL	ISSUE	DATE
DCB	6:01	01-05-00

SHEET9

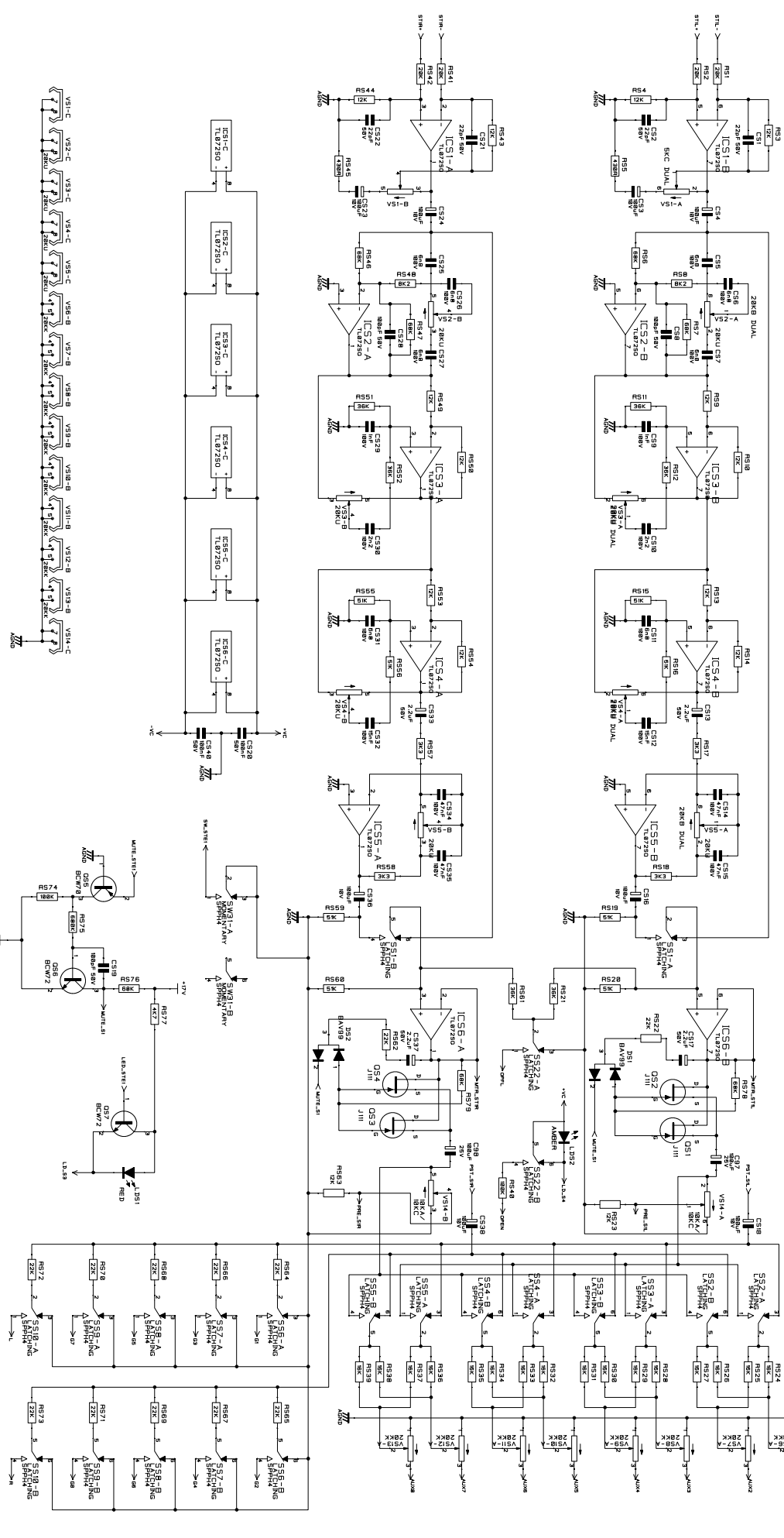

NOTES

SOUNDRAFT OWNS THE COPYRIGHT OF THIS DRAWING WHICH IS NOT TO BE A THIRD PARTY WITHOUT WRITTEN PERMISSION.

DRN. GHB

DATE

SOUNDRAFT INDUSTRIES LTD.  
HARMAN INT.  
CRANBORNE HOUSE,  
CRANBORNE ROAD,  
POTTERS BAR, TN.  
TELEPHONE: 01753 634000  
FAX: 01753 650482

TITLE

SERIES TWO  
MASTER

DRG NO. ED4020

INITIAL	ISSUE	DATE
DCB	6:01	01-05-00

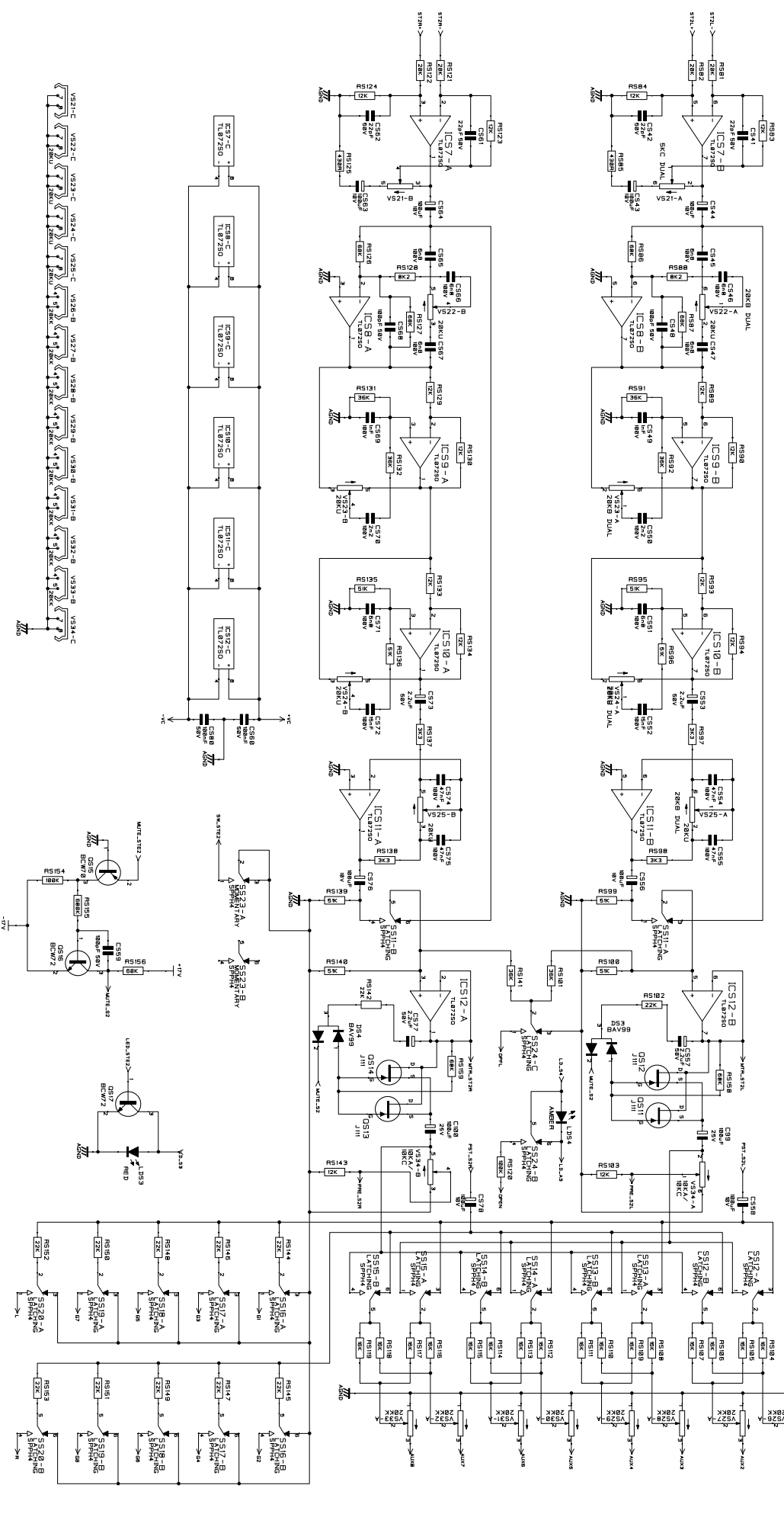

NOTES

SOUNDCRAFT OWNS THE COPYRIGHT OF THIS DRAWING WHICH IS NOT TO BE A THIRD PARTY WITHOUT WRITTEN PERMISSION.

DRN. GHB

DATE

TITLE

SOUNDCRAFT INDUSTRIES LTD.  
HARMAN INT. HOUSE,  
CRANBORNE ROAD,  
POTTERS BAR, TN,  
HERTS. EN9 6JQ  
TEL: 01707 650092  
FAX: 01707 650482

SERIES TWO  
MASTER

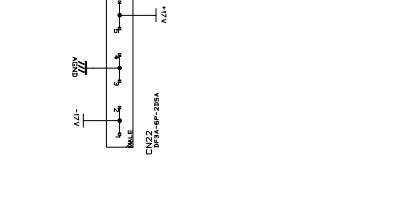
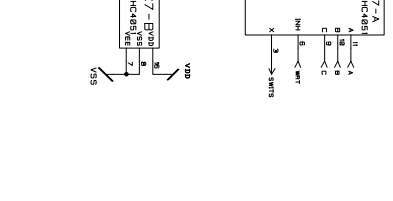
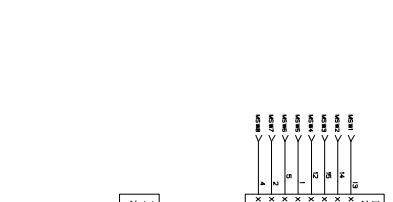
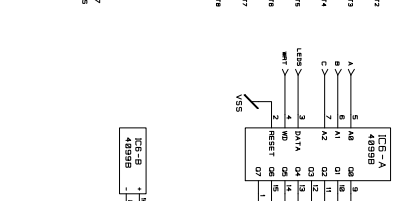
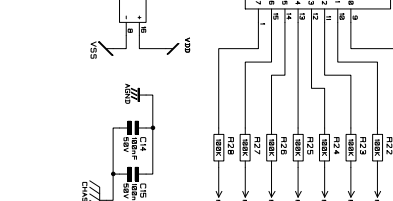
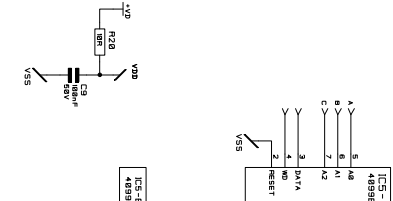
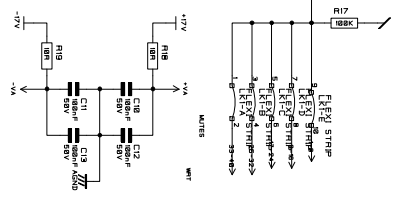
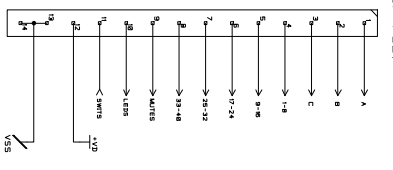
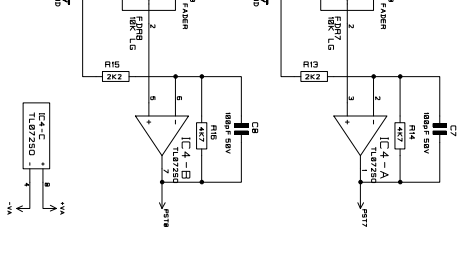
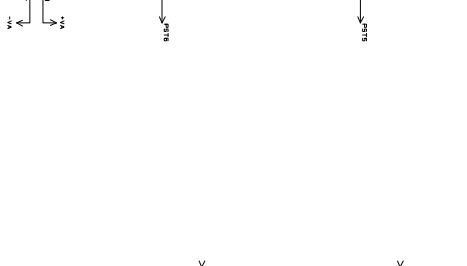
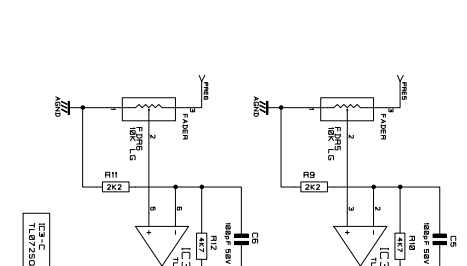
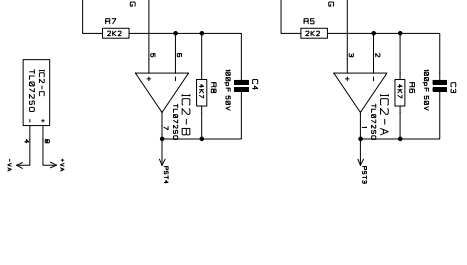
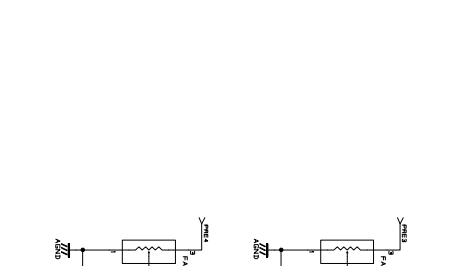
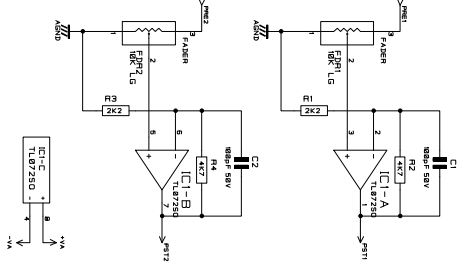
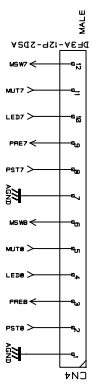
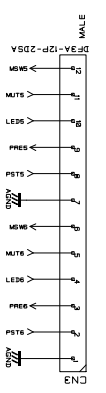
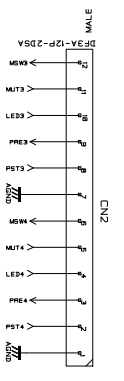
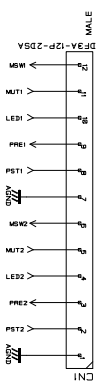

CNS HDR BIL 14 V  
PUT CNS ON BACK  
OF PCB.

USE OPEN 10W HDR OR  
2 ROWS OF 5 PIN SIL  
TO MAKE INTO JUMPERS.

NOTES

SOUNDCRAFT OWNS THE COPYRIGHT OF  
THIS DRAWING WHICH IS NOT TO BE  
REPRODUCED OR TRANSMITTED IN ANY  
FORM OR BY ANY MEANS, ELECTRONIC  
OR MECHANICAL, INCLUDING PHOTOCOPYING,  
RECORDING, OR BY ANY INFORMATION  
STORAGE AND RETRIEVAL SYSTEM,  
WITHOUT THE WRITTEN PERMISSION OF  
SOUNDCRAFT.

DRN:

GHB

DATE

TITLE

BLYTH LIVE  
INPUT FADER

SOUNDCRAFT INDUSTRIES LTD.  
HARMAN INT. HOUSE,  
CRANBORNE ROAD,  
POTTERS BAR, TN,  
UK.  
TELEPHONE: 01753 654000  
FAX: 01753 650482

DRG NO. ED4021

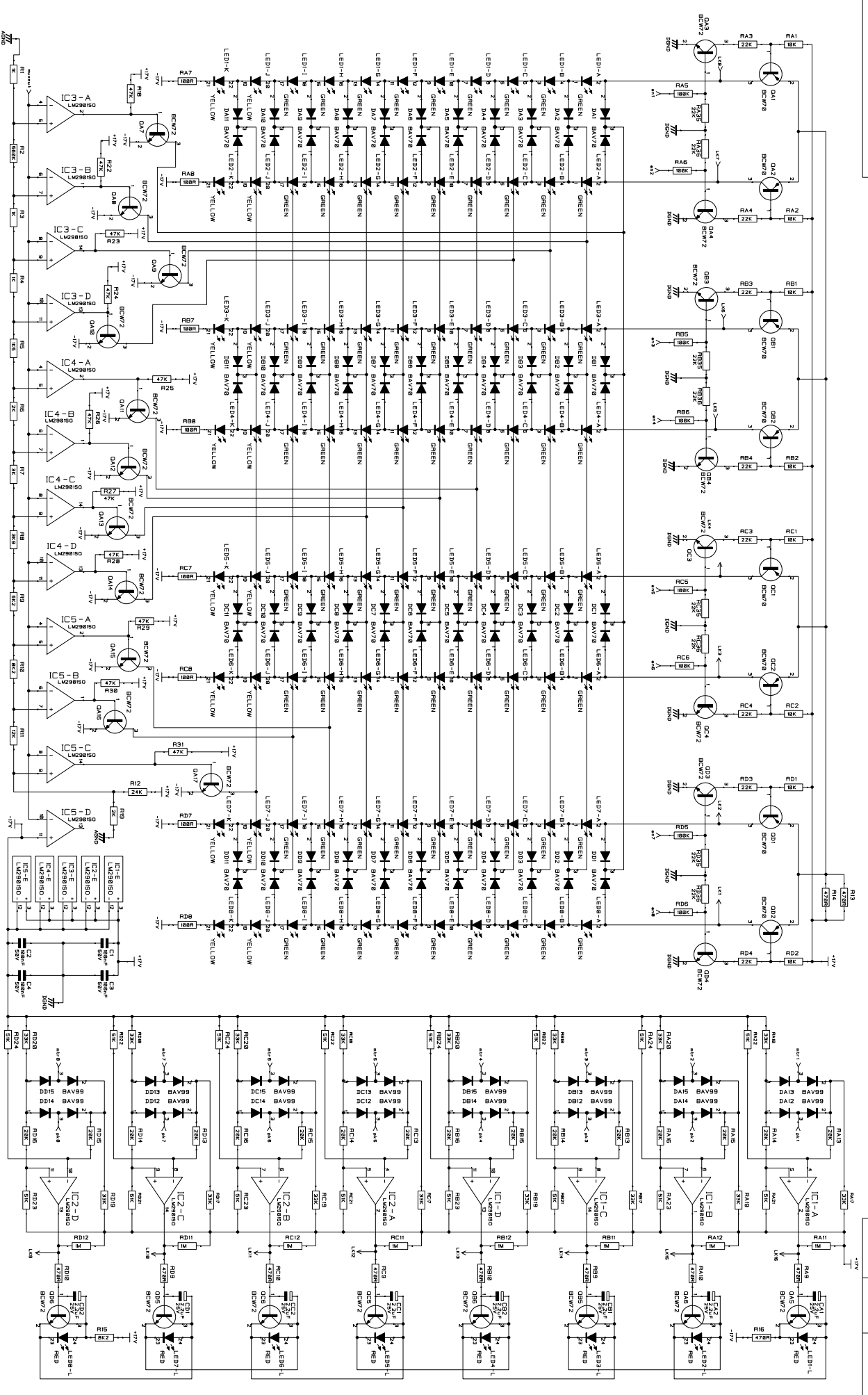

INITIAL	ISSUE	DATE
DCB	6:01	08-03-00

NOTES

SOUNDCRAFT OWNS THE COPYRIGHT OF THIS DRAWING WHICH IS NOT TO BE A THIRD PARTY WITHOUT WRITTEN PERMISSION.

DRN: GH8

DATE

SOUNDCRAFT INDUSTRIES LTD.  
 HAINMAN NT HOUSE,  
 CRANBORNE ROAD,  
 POTTERS BAR, TN,  
 HERTS, EN9 6JL  
 TEL: 01753 650092  
 FAX: 01753 650482

TITLE  
 SERIES TWO  
 METER BOARD

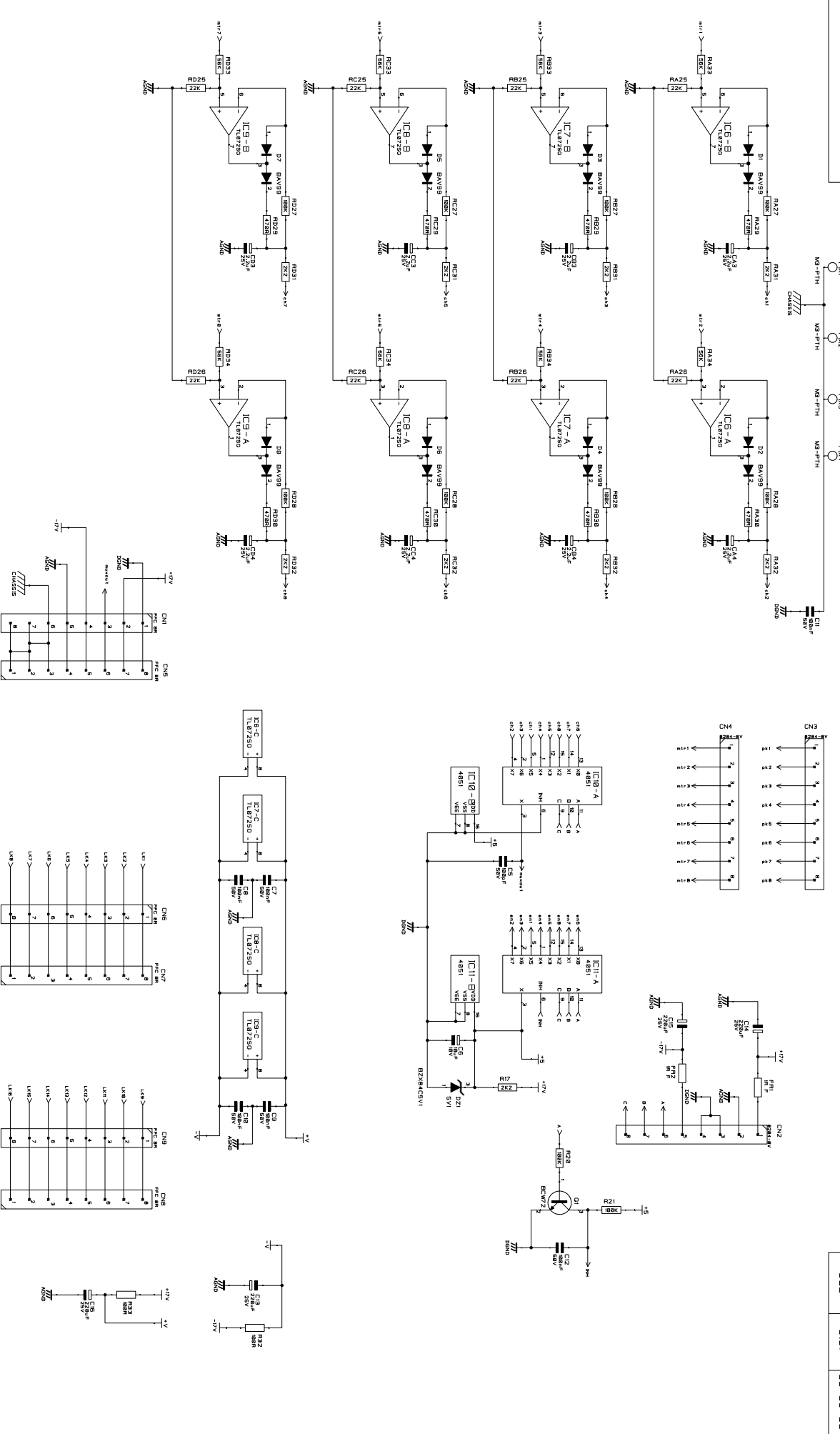

NOTES

SOUNDRAFT OWNS THE COPYRIGHT OF THIS DRAWING WHICH IS NOT TO BE A THIRD PARTY WITHOUT WRITTEN PERMISSION.

DRN: GHB

DATE

SOUNDRAFT INDUSTRIES LTD.  
 HARMAN NT HOUSE,  
 CRANBORNE ROAD,  
 POTTERS BAR, TN  
 HERTS, SG9 6SD  
 TEL: 01753 550092  
 FAX: 01753 550482

TITLE  
 SERIES TWO  
 METER BOARD

DRG NO. ED4022

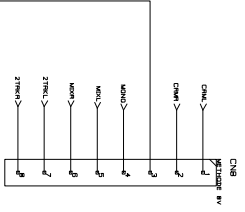
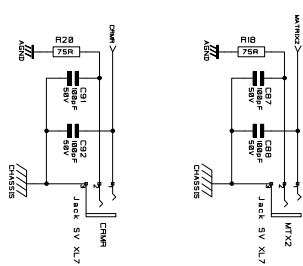
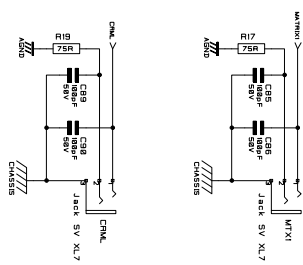
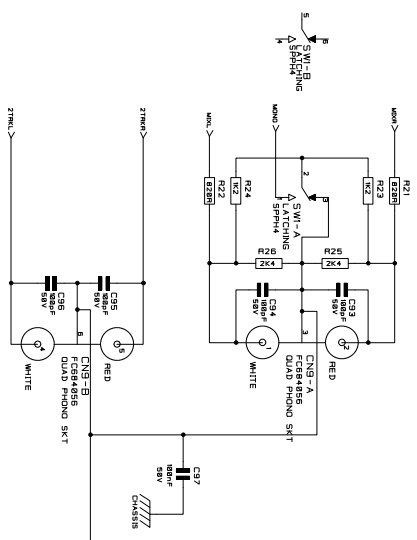
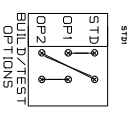
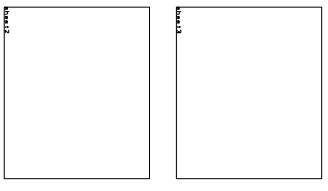
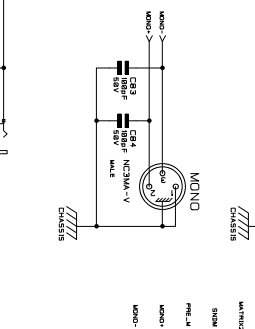
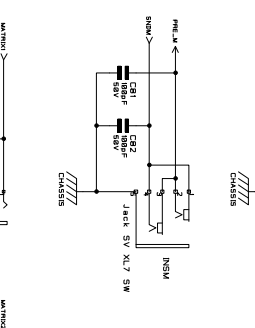
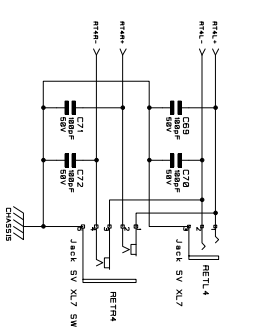
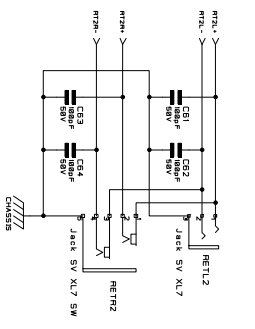
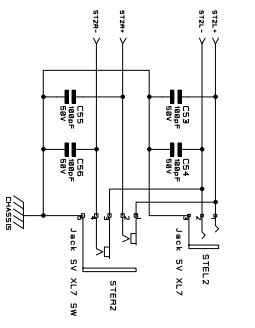
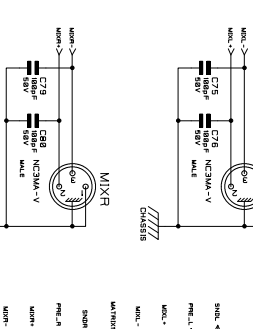
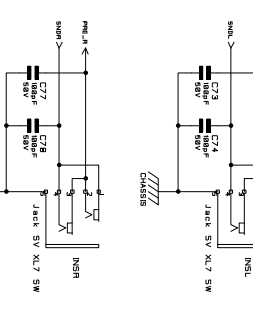
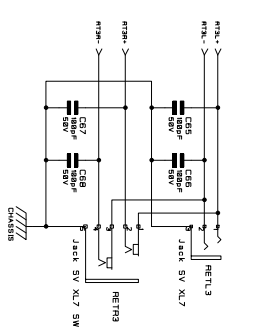
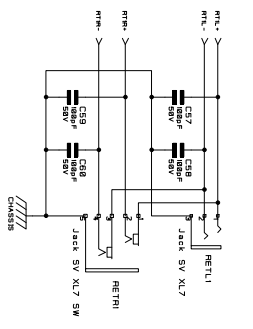
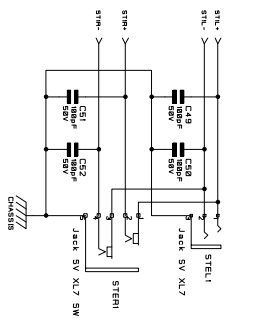
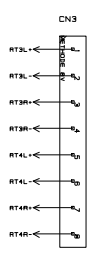
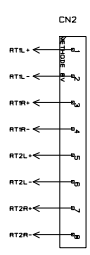
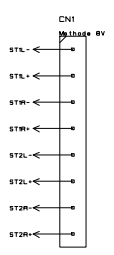

NOTES

SOUNDCRAFT OWNS THE COPYRIGHT OF THIS DRAWING WHICH IS NOT TO BE A THIRD PARTY WITHOUT WRITTEN PERMISSION.

DRN: \*\*\*

DATE 00-00-00

SOUNDCRAFT INDUSTRIES LTD.  
HARMAN INT. HOUSE,  
CRANBORNE ROAD,  
POTTERS BAR, TN  
HERTS, EN9 5SD  
TEL: 01753 650092  
FAX: 01753 650482

TITLE  
SERIES TWO  
Rearconn & Mid

DRG NO. ED4025

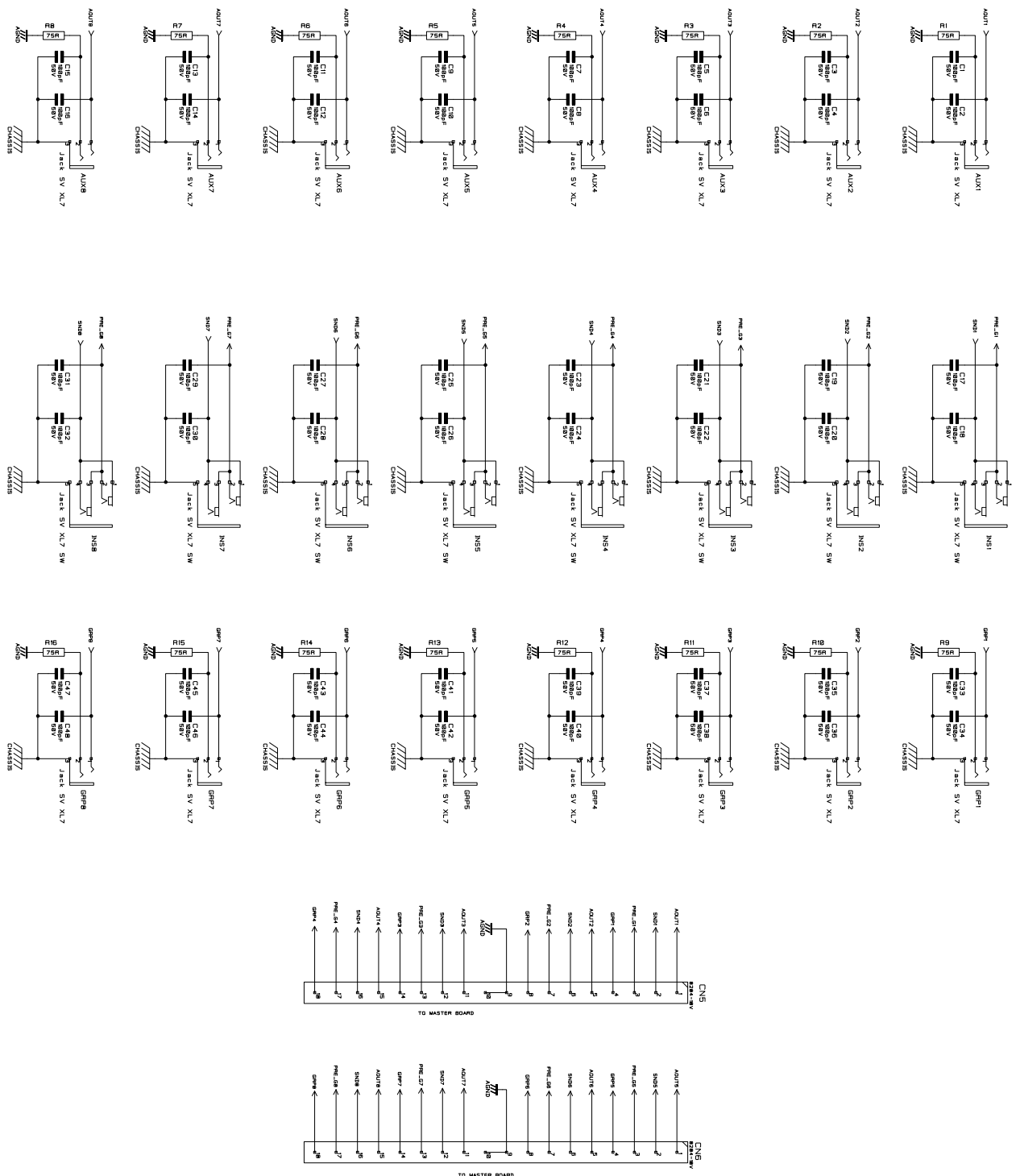

NOTES

SOUNDCRAFT OWNS THE COPYRIGHT OF THIS DRAWING WHICH IS NOT TO BE A THIRD PARTY WITHOUT WRITTEN PERMISSION.

DRN: \*\*\*

DATE 00-00-00

SOUNDCRAFT INDUSTRIES LTD.  
HARMANN T. HOUSE,  
CRANBORNE ROAD,  
POTTERS BAR, IN.  
TEL: 01753 650092  
FAX: 01753 650482

TITLE SERIES TWO  
Rearconn & MidI

DRG NO. ED4025



INITIAL	ISSUE	DATE
TW	4:02	4-7-00

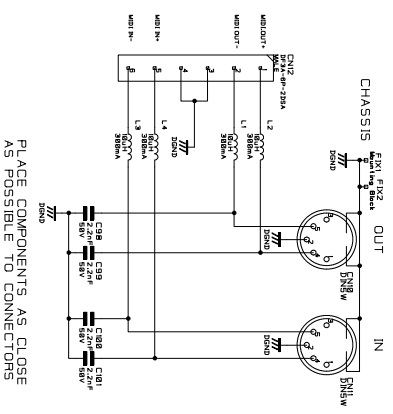

PLACE COMPONENTS AS CLOSE AS POSSIBLE TO CONNECTORS

NOTES

SOUNDCRAFT OWNS THE COPYRIGHT OF THIS DRAWING WHICH IS NOT TO BE A THIRD PARTY WITHOUT WRITTEN PERMISSION.

DRN: \*\*\*

DATE 00-00-00

SOUNDCRAFT  
HARMONY INDUSTRIES LTD.  
CRANBORNE HOUSE  
CRANBORNE ROAD.  
POTTERS BAR, IN.  
HERTS. EN9 5JL  
TELEPHONE 520092  
FAX: 01757 550482

TITLE  
SERIES TWO  
Rearconn & Midi

DRG NO. ED4025

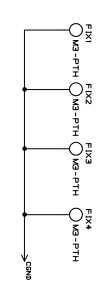
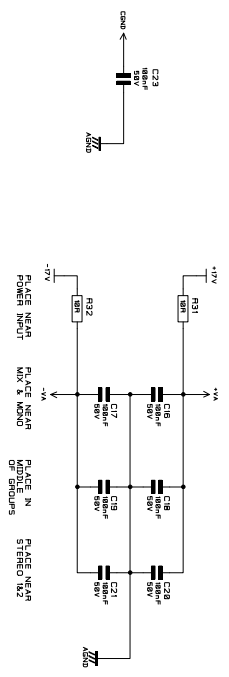
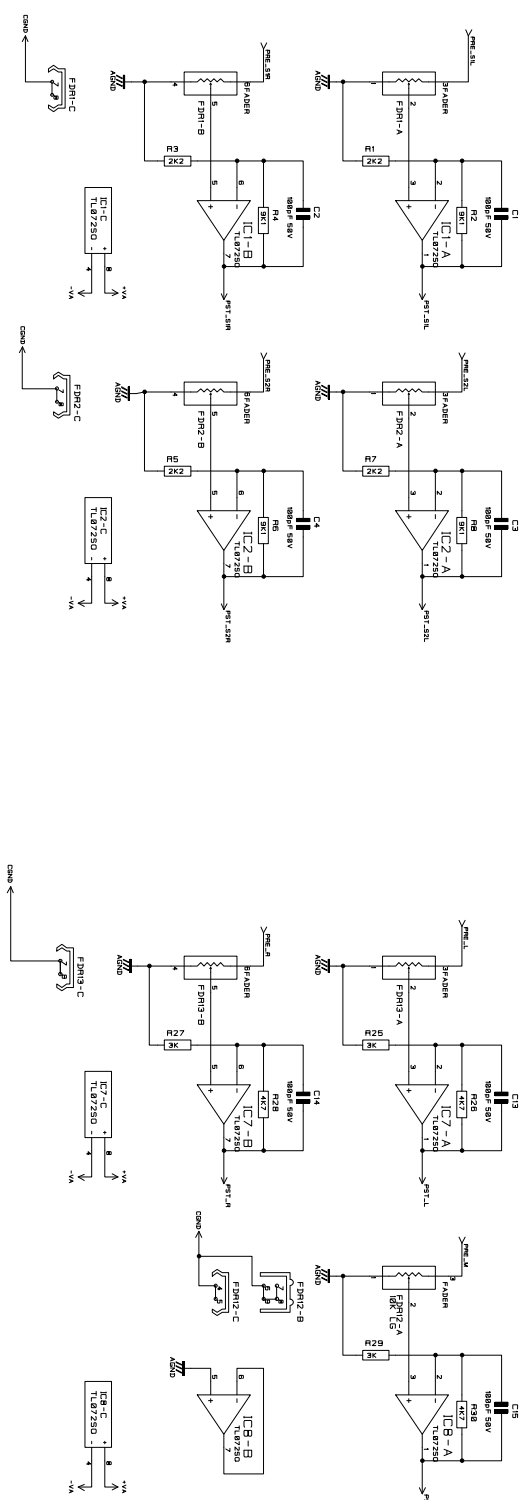
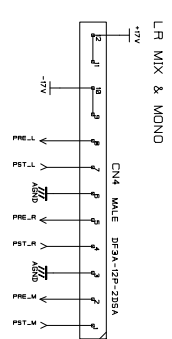
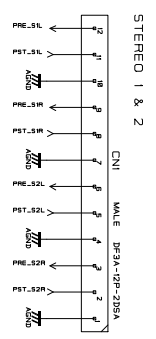

NOTES

SOUNDCRAFT OWNS THE COPYRIGHT OF THIS DRAWING WHICH IS NOT TO BE A THIRD PARTY WITHOUT WRITTEN PERMISSION.

DRN:

YS  
DATE 11-02-99

TITLE

SERIES TWO  
OUTPUT FADER PCB  
STEREO, LR & MONO FADERS

SOUNDCRAFT INDUSTRIES LTD.  
HARMANT HOUSE,  
CRANBORNE ROAD,  
POTTERS BAR, IN.  
HERTS, SG9 6SL  
TEL: 01753 650092  
FAX: 01753 650482

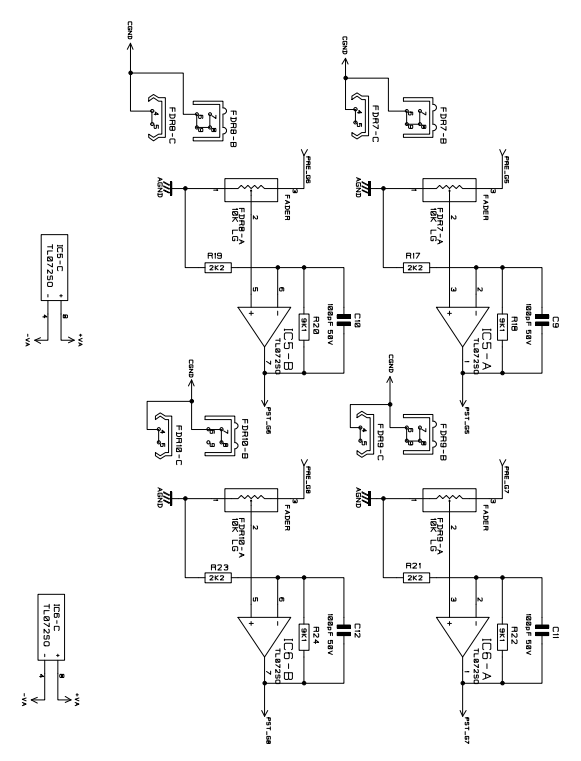
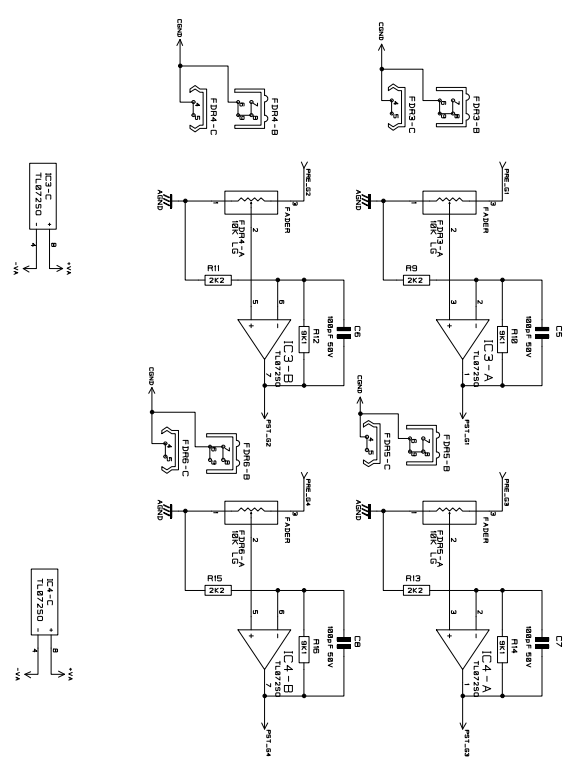
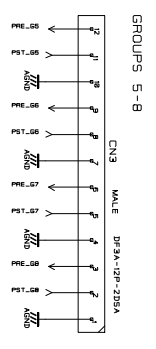
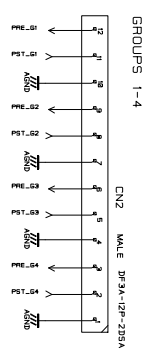

NOTES

SOUNDCRAFT OWNS THE COPYRIGHT OF THIS DRAWING WHICH IS NOT TO BE A THIRD PARTY WITHOUT WRITTEN PERMISSION.

DRN.

YS  
DATE 11-02-99

TITLE

SOUNDCRAFT INDUSTRIES LTD.  
HARMANT HOUSE  
CRANBORNE ROAD.  
POTTERS BAR, TN.  
HERTS. SG9 6SL002  
FAX: 01767 550482

DRG. NO. ED4026

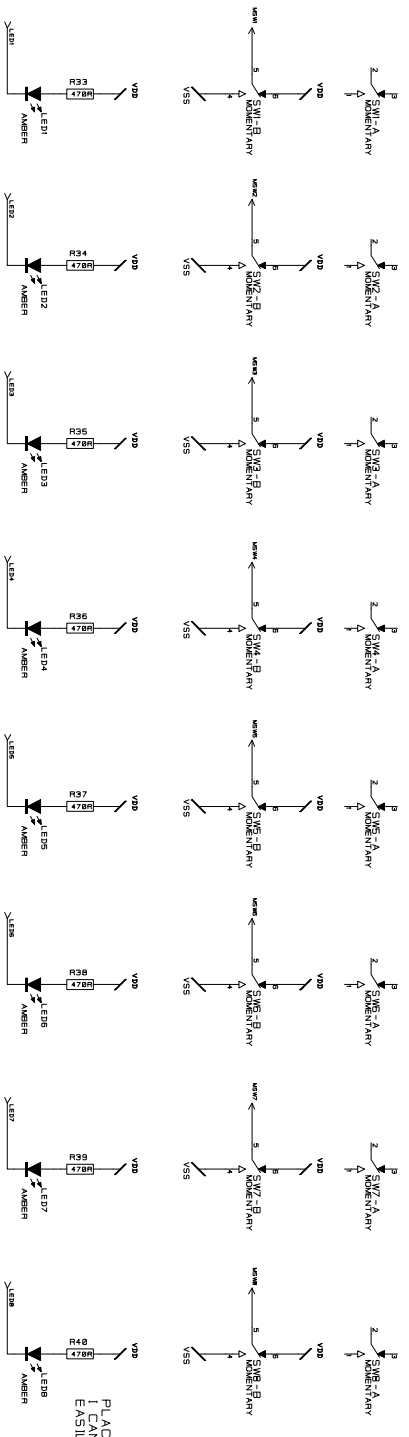

PLACE RESISTORS SO I CAN RESOLDER THEM EASILY!

FLOOD FILL WITH VAS

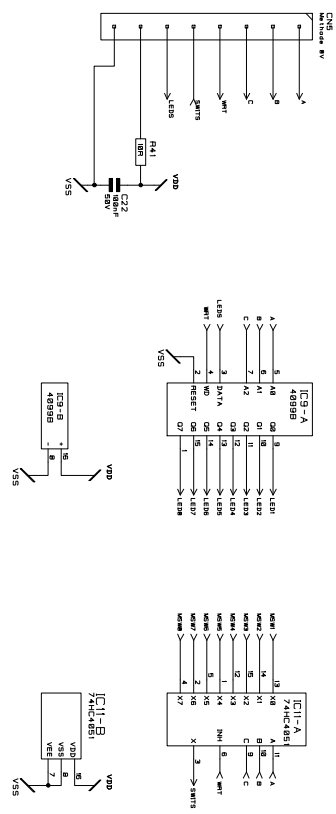

HEADPHONE SOCKET

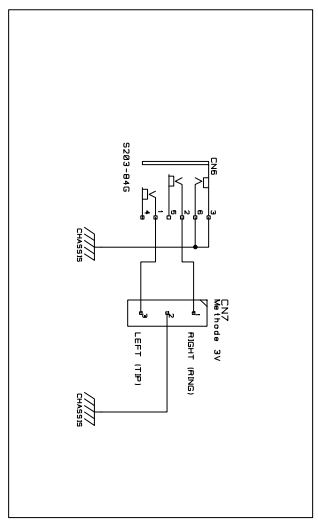

FLOOD FILL WITH CHASSIS. KEEP CHASSIS FLOOD AT LEAST 5mm AWAY FROM VAS FLOOD FILL

NOTES

SOUNDCRAFT OWNS THE COPYRIGHT OF THIS DRAWING WHICH IS NOT TO BE A THIRD PARTY WITHOUT WRITTEN PERMISSION.

DRN:

YES

DATE

11-02-99

TITLE

SERIES TWO OUTPUT FADER PCB W/TE GROUP PCB

SOUNDCRAFT HARMANN INT. INDUSTRIES LTD. CRANBORNE HOUSE. CRANBORNE ROAD. POTTERS BAR, TN. HERTS. EN9 5SD  
TEL: 01767 550092 FAX: 01767 550482

DRG NO.

ED4026

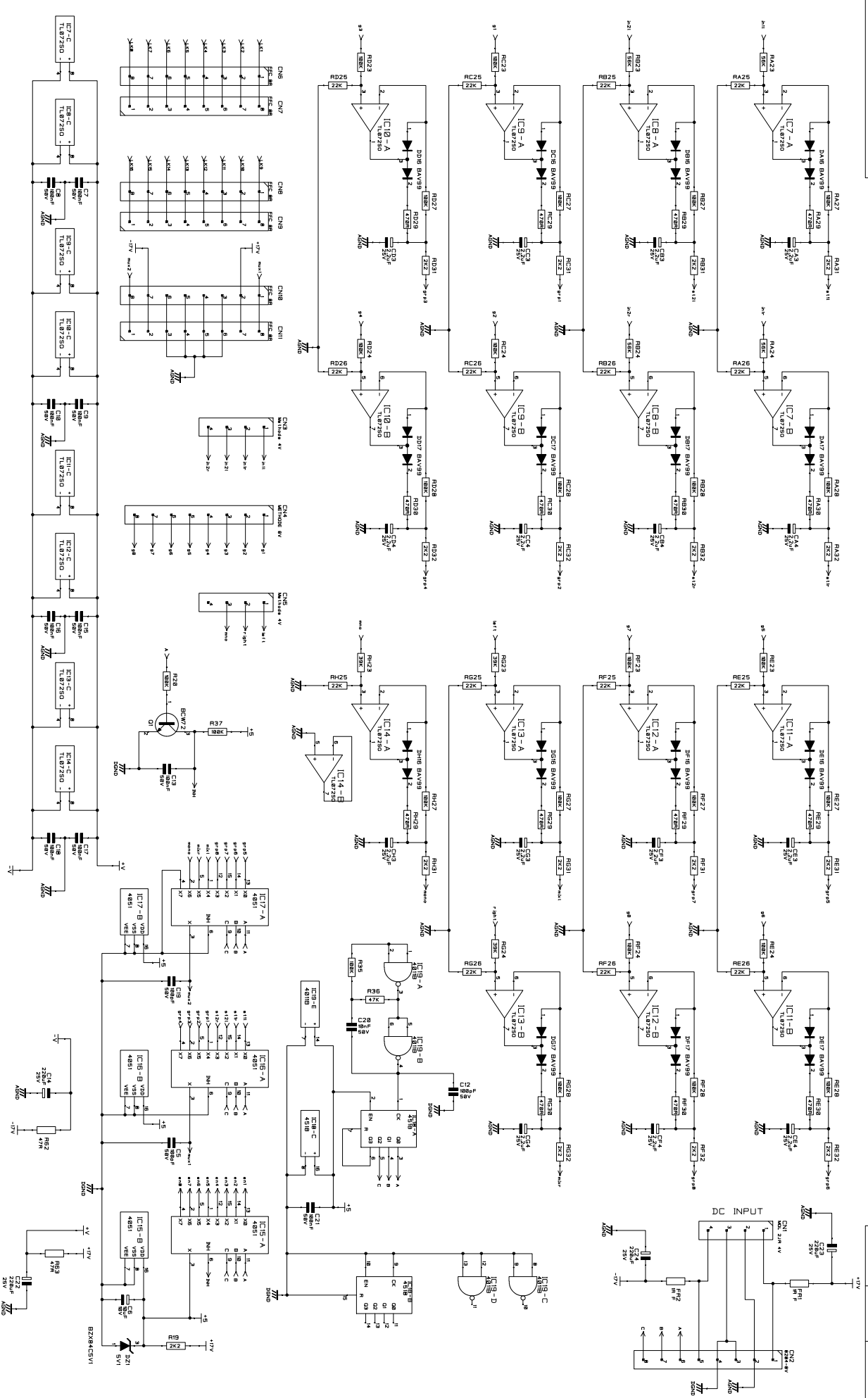

NOTES

SOUNDRAFT OWNS THE COPYRIGHT OF THIS DRAWING WHICH IS NOT TO BE COPIED, IN PART OR IN WHOLE TO A THIRD PARTY WITHOUT WRITTEN PERMISSION.

DRN. GHB

DATE 22-02-99

TITLE

SOUNDRAFT HARMAN INT. INDUSTRIES LTD.  
 GRANBORNE HOUSE,  
 GRANBORNE ROAD,  
 HERTINGHAM,  
 HANTS RG27 9JN  
 TEL: 01707 665000  
 FAX: 01707 660482

DRG NO. ED4027

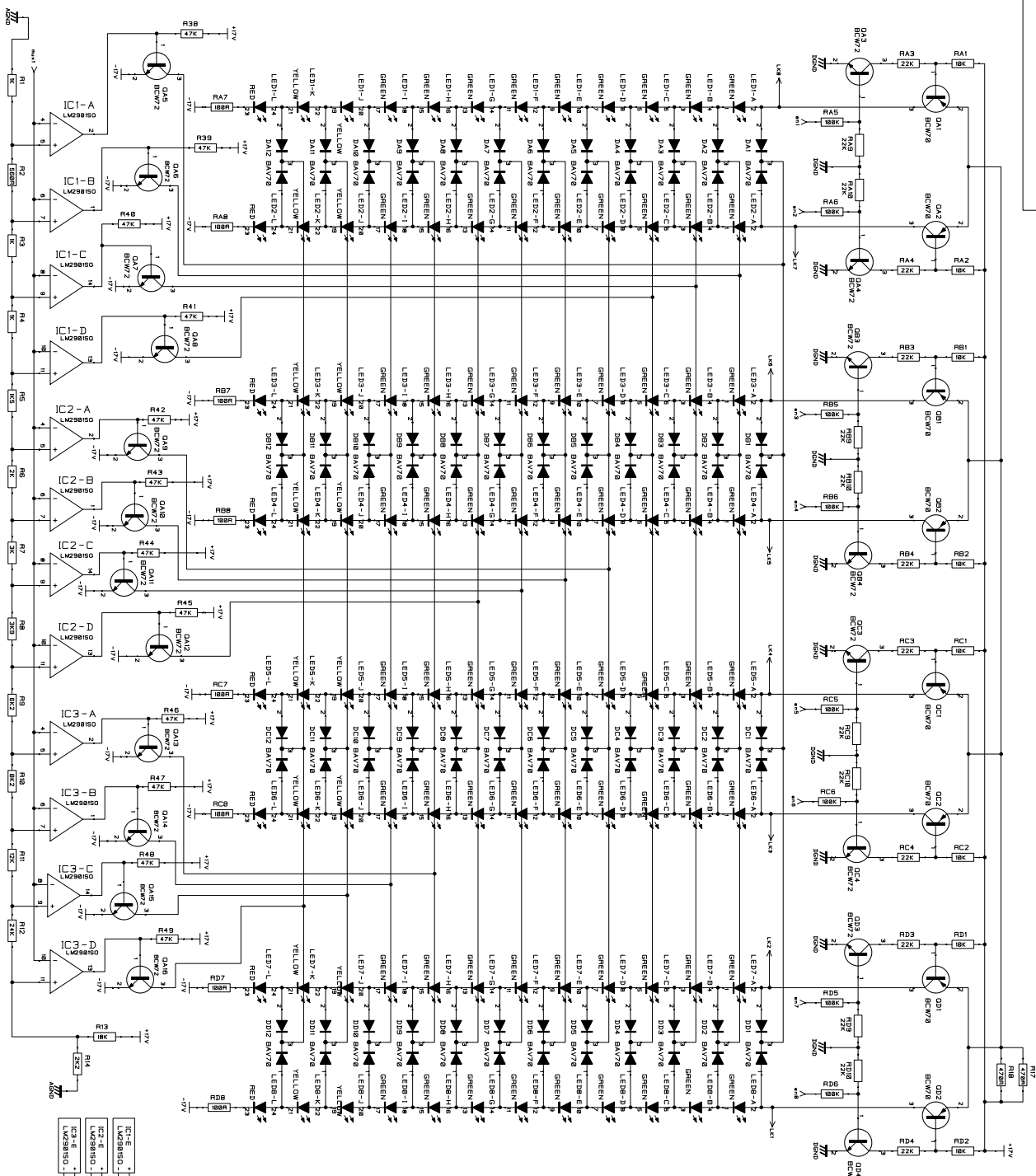

NOTES

SOUNDCRAFT OWNS THE COPYRIGHT OF THIS DRAWING WHICH IS NOT TO BE A THIRD PARTY WITHOUT WRITTEN PERMISSION.

DRN: GHB

DATE 22-02-99

SOUNDCRAFT INDUSTRIES LTD.  
 HARMAN INT. HOUSE,  
 CRANBORNE ROAD,  
 POTTERS BAR, TN,  
 HERTS, SG9 6SL  
 TEL: 01753 650099  
 FAX: 01753 650482

TITLE

SERIES TWO  
 O/P METER

DRG NO. ED4027

INITIAL	ISSUE	DATE
TW	6:02	19-4-00

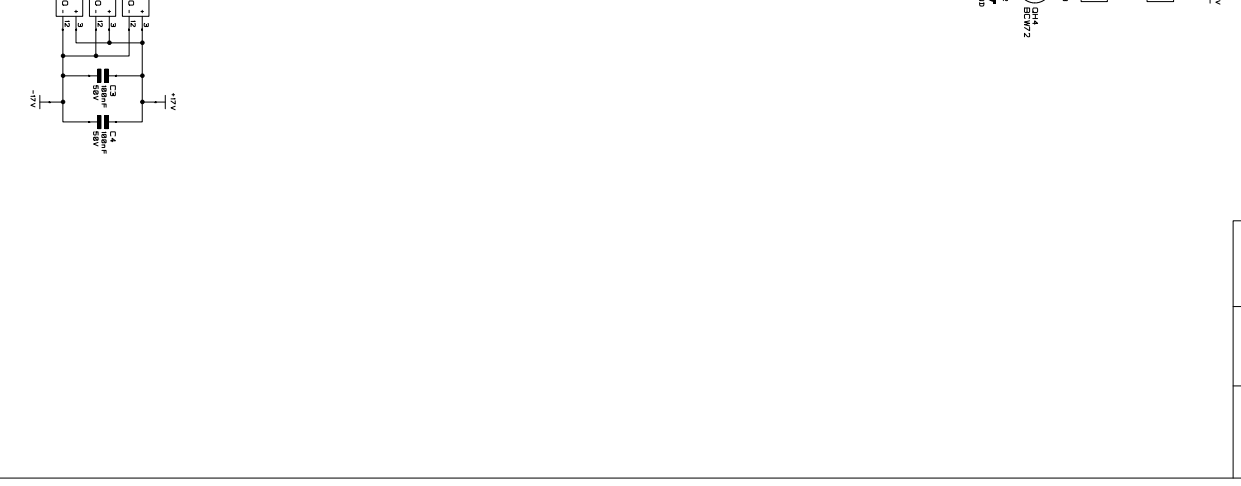
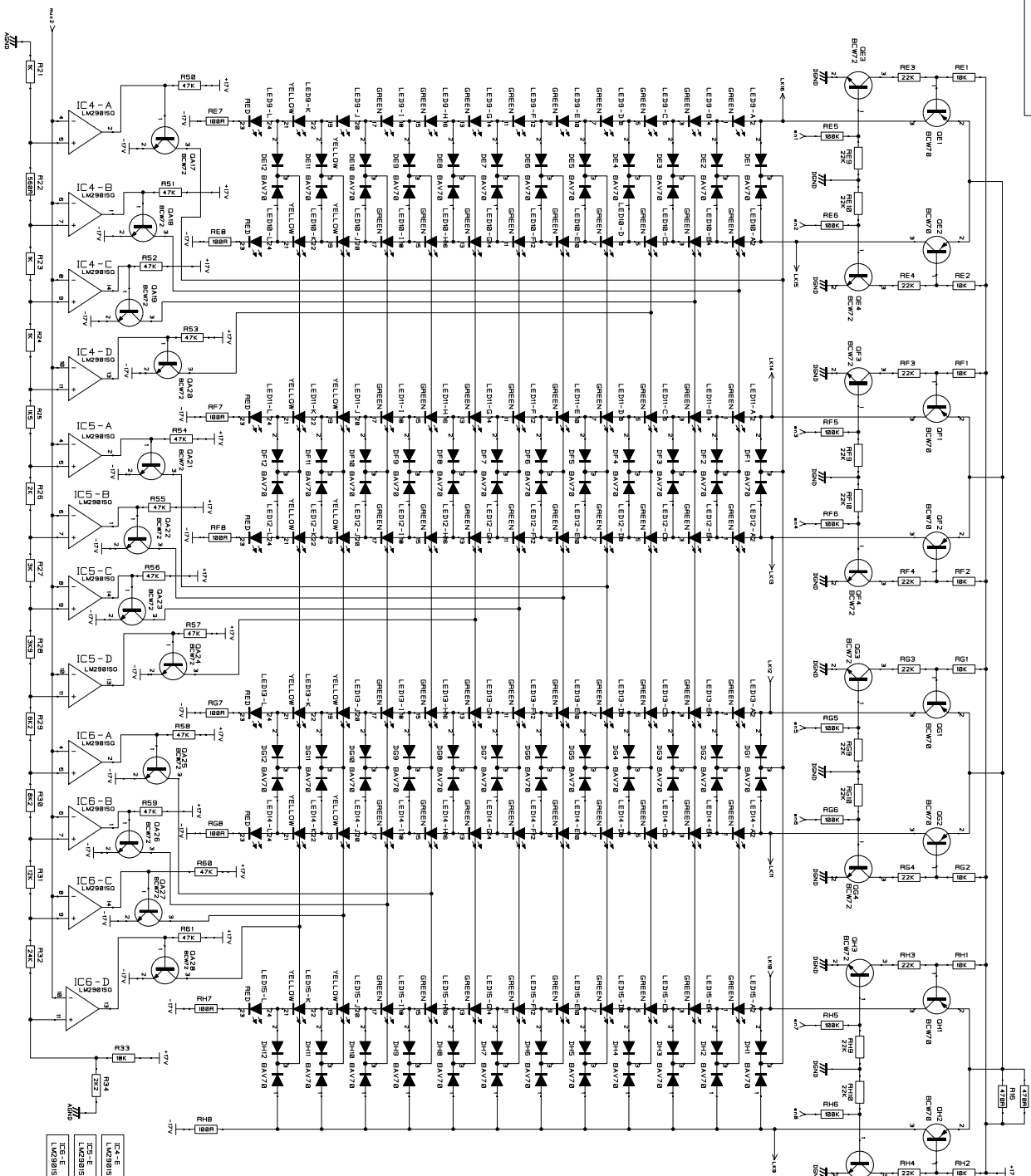

NOTES

DRN. GHB

TITLE SERIES TWO O/P METER

SOUNDCRAFT OWNS THE COPYRIGHT OF THIS DRAWING WHICH IS NOT TO BE A THIRD PARTY WITHOUT WRITTEN PERMISSION.

DATE 22-02-99

SOUNDCRAFT INDUSTRIES LTD.  
 HARMAN INT. HOUSE,  
 CRANBORNE ROAD,  
 POTTERS BAR, IN.  
 HERTS. EN9 6JQ  
 TEL: 01763 550099  
 FAX: 01763 550182

DRG NO. ED4027

DRG NO. ED4028

INITIAL	ISSUE	DATE
YS	1:00	11-03-99

Microcontroller

Fader Servos 1-4

Fader Servos 5-8

Channel Interface

NOTES

SOUNDCRAFT OWNS THE COPYRIGHT OF THIS DRAWING WHICH IS NOT TO BE A THIRD PARTY WITHOUT WRITTEN PERMISSION.

DEN: YES

DATE 11-03-99

SOUNDCRAFT  
HARMONY INDUSTRIES LTD.  
HARMONY HOUSE  
CRANBORNE ROAD.  
POTTERS BAR, IN.  
HERTS, EN9 6SD  
TEL: 01753 650092  
FAX: 01753 650482

TITLE

SERIES TWO  
MOVING FADER  
INTERFACE PCB

DRG NO. ED4028





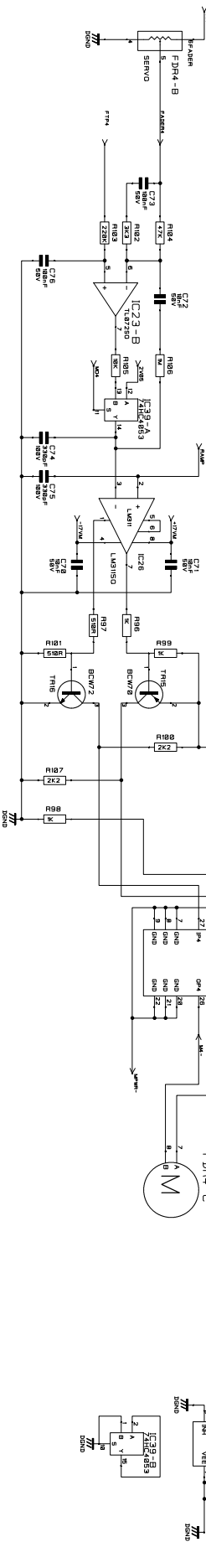
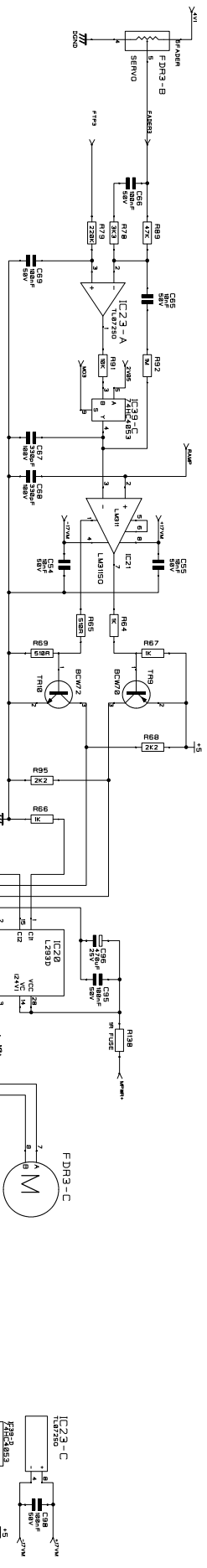
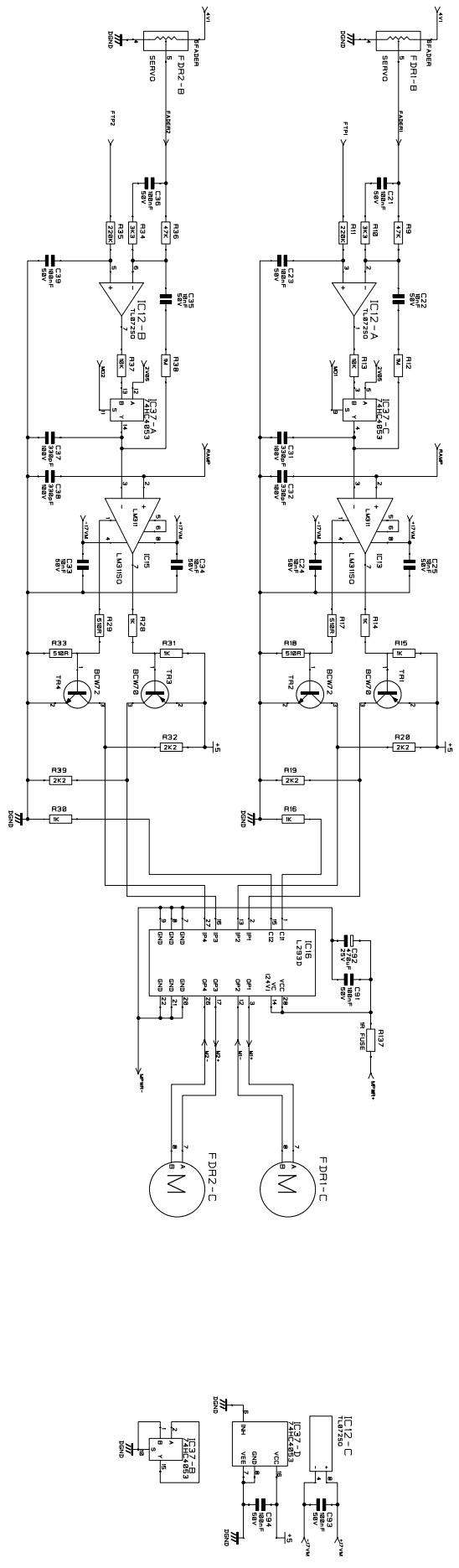

FADER SERVOS 1-4

NOTES

SOUNDRAFT OWNS THE COPYRIGHT OF THIS DRAWING WHICH IS NOT TO BE A THIRD PARTY WITHOUT WRITTEN PERMISSION.

DRN: YS

DATE 11-03-99

SOUNDRAFT INDUSTRIES LTD.  
 HARMAN INT. HOUSE,  
 CRANBORNE ROAD,  
 POTTERS BAR, TN.  
 TEL: 0189 543000  
 FAX: 01787 550482

TITLE

SERIES TWO  
 MOVING FADER  
 INTERFACE PCB

DRG NO. ED4028

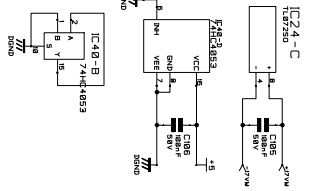
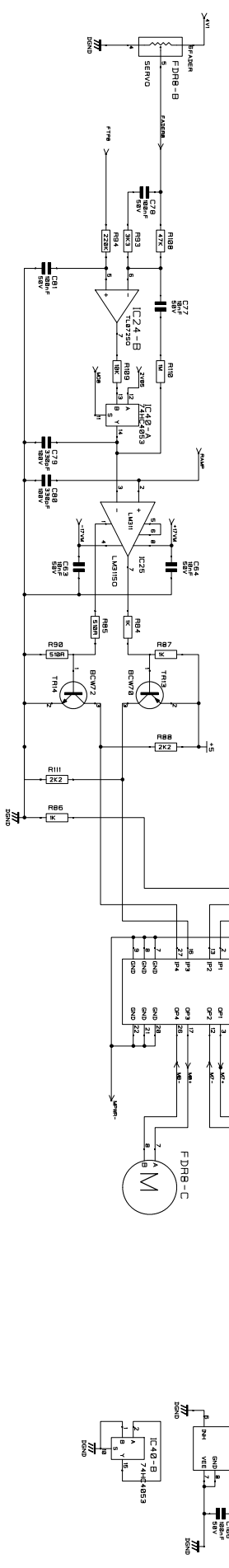
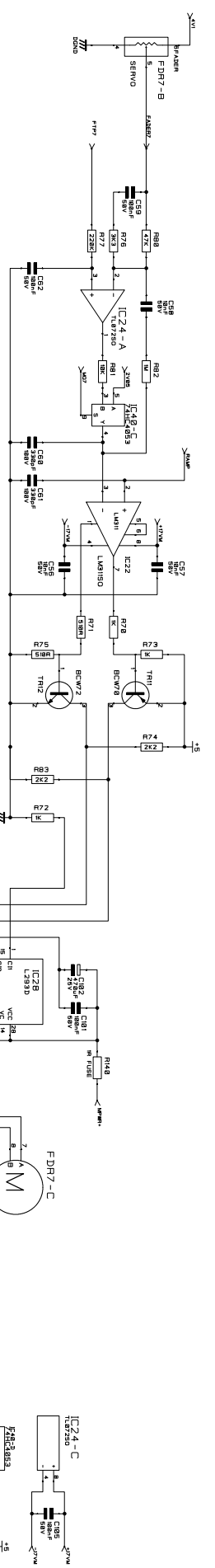
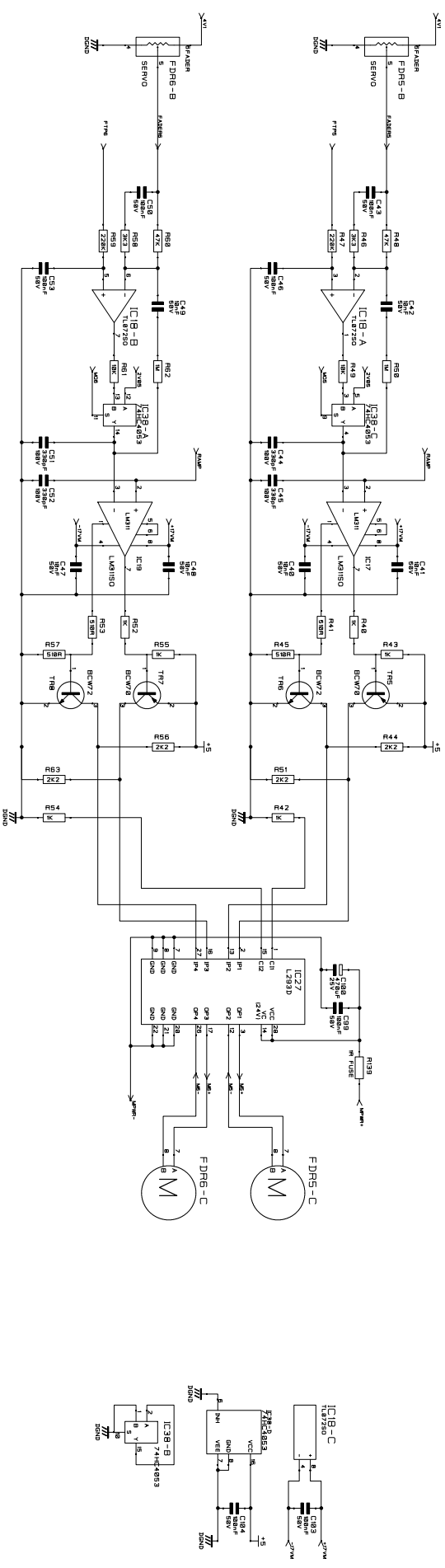

FADER SERVOS 5-8

NOTES

SOUNDRAFT OWNS THE COPYRIGHT OF THIS DRAWING WHICH IS NOT TO BE A THIRD PARTY WITHOUT WRITTEN PERMISSION.

DRN: YS

DATE 11-03-99

TITLE

SERIES TWO MOVING FADER INTERFACE PCB

SOUNDRAFT INDUSTRIES LTD.  
HARMAN INT. HOUSE,  
CRANBORNE ROAD,  
POTTERS BAR, IN.  
HERTS, SG9 6SD  
TEL: 01753 650092  
FAX: 01753 650482

DRG NO. ED4028

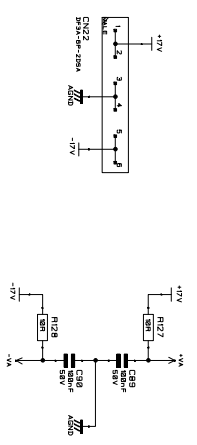
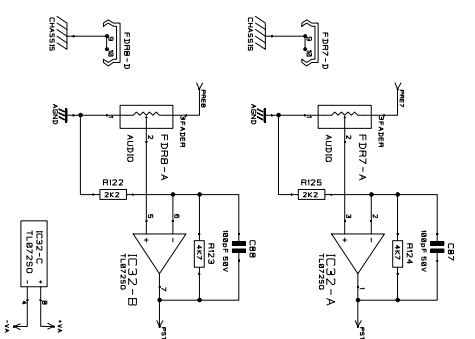
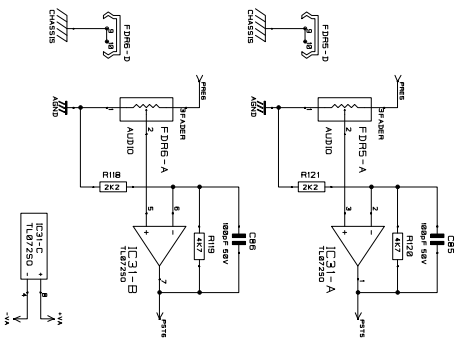
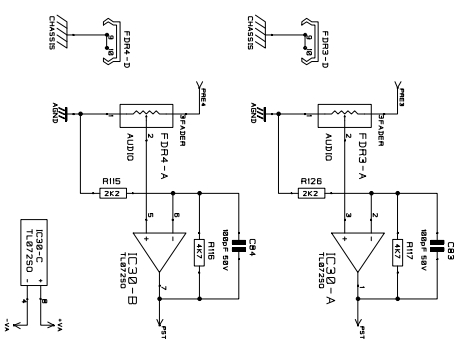
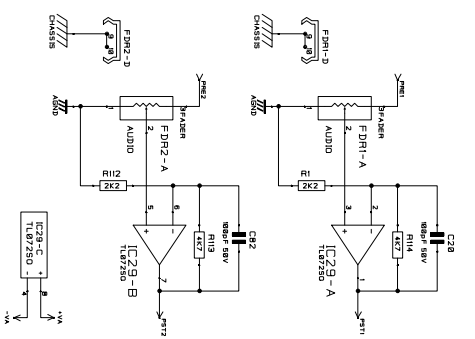
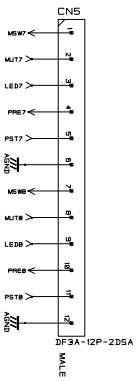
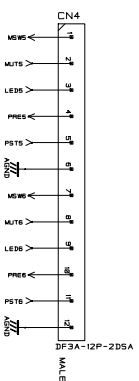
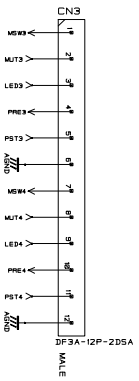
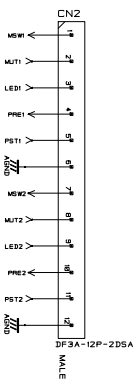

CHANNEL INTERFACE

NOTES

SOUNDRAFT OWNS THE COPYRIGHT OF THIS DRAWING WHICH IS NOT TO BE A THIRD PARTY WITHOUT WRITTEN PERMISSION.

CAUTION - AUDIO CIRCUITRY KEEP AWAY FROM DIGITAL AND SERVO CIRCUITS AND PLACE IN "AGND" GROUND PLANE. SEPARATE ANALOGUE AND DIGITAL GROUND PLANES BY AT LEAST 5mm

DRN: YS

DATE 11-03-99

TITLE

SERIES TWO MOVING FIBER INTERFACE PCB

DRG NO. ED4028

SOUNDRAFT HARMAN INT. INDUSTRIES LTD. CRANBORNE HOUSE, CRANBORNE ROAD, POTTERS BAR, HERTS, EN9 5AF, UK. TEL: 01753 650000 FAX: 01753 650482

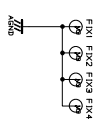
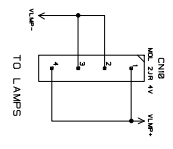
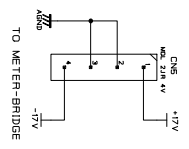
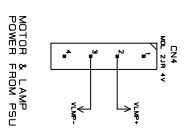
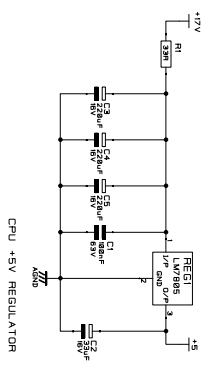
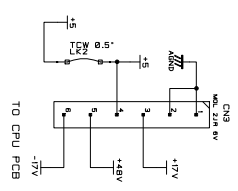
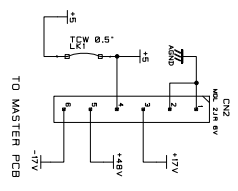
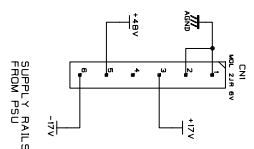

NOTES

SOUNDCRAFT OWNS THE COPYRIGHT OF THIS DRAWING WHICH IS NOT TO BE A THIRD PARTY WITHOUT WRITTEN PERMISSION.

DRAWN: GB/Yans

DATE: 04-01-00

SOUNDCRAFT  
HARMANN INT. INDUSTRIES LTD.  
CRANBORNE HOUSE  
CRANBORNE ROAD.  
POTTERS BAR, IN.  
HERTS. SG9 5SL  
TEL: 01753 650092  
FAX: 01753 650482

TITLE: SERIES TWO  
PSU DISTRIBUTION PCB

DRG NO. ED4041

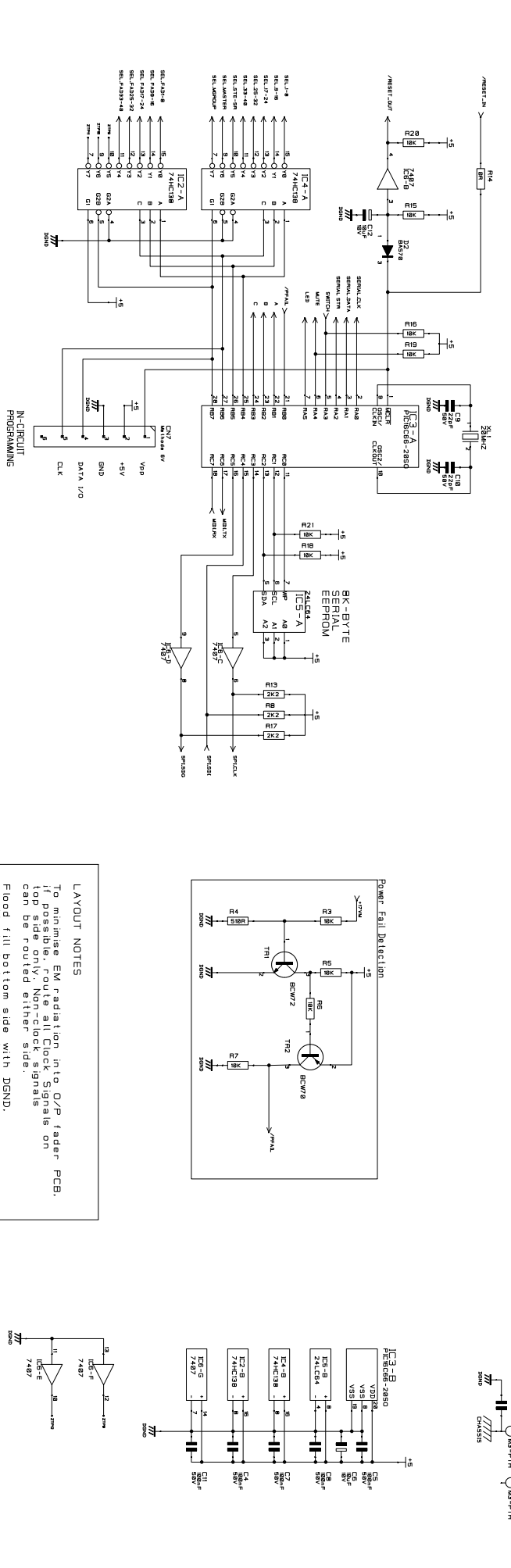
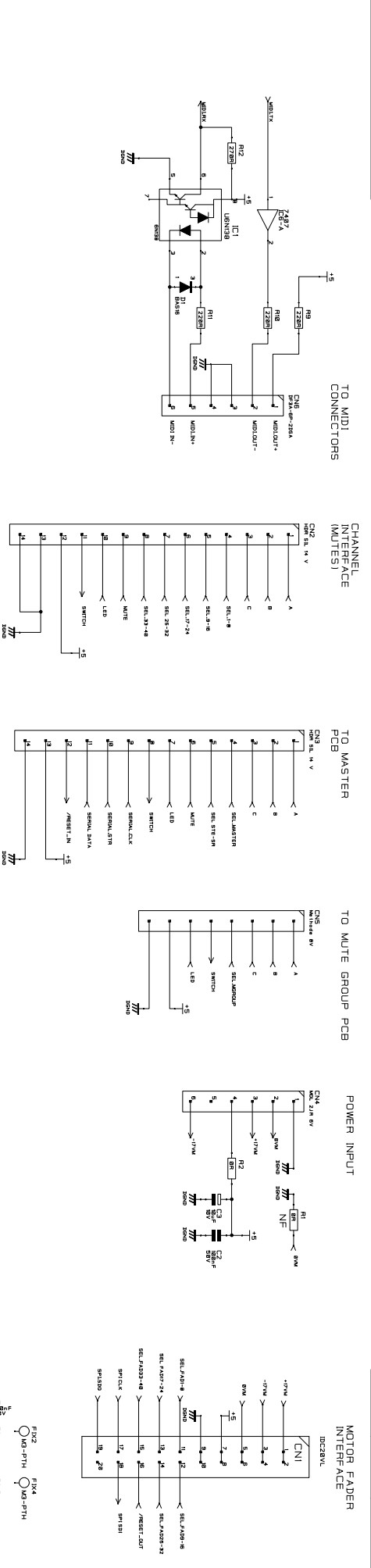

**LAYOUT NOTES**  
 To minimise EM radiation into O/P fader PCB, if possible, route all Clock Signals on top side only. Non-clock signals can be routed either side.  
 Flood fill bottom side with DGND. Particularily beneath microprocessor and, if possible beneath logic ICs.  
 Flood-fill top side with DGND also.

NOTES

SOUNDCRAFT OWNS THE COPYRIGHT OF THIS DRAWING WHICH IS NOT TO BE A THIRD PARTY WITHOUT WRITTEN PERMISSION.

DRN:	YS
DATE	24-05-99

TITLE	SERIES TWO
	MUTE AUTOMATION
	GPU PCB

INITIAL	ISSUE	DATE
TW	2.03	4-7-00

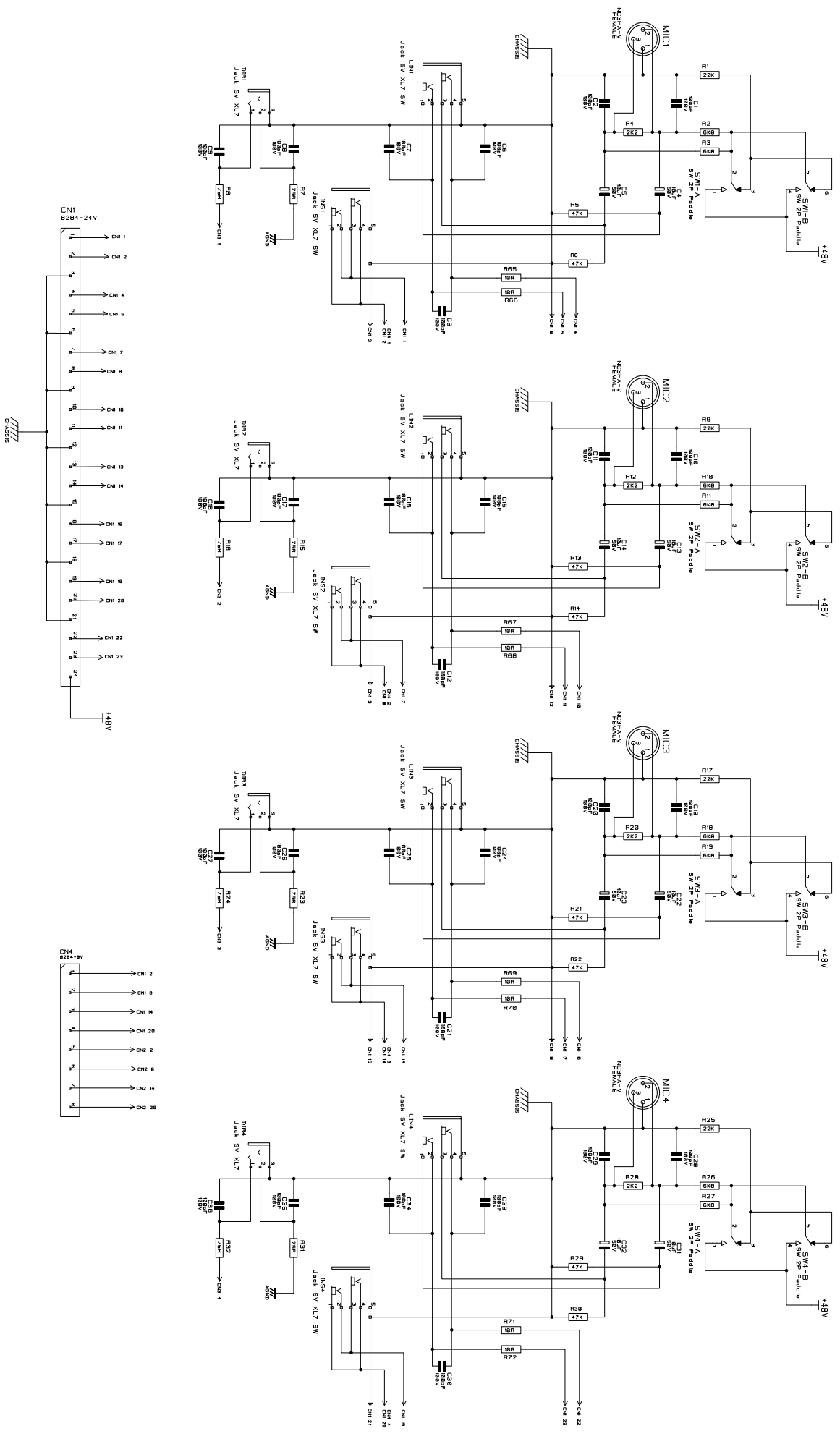

NOTES

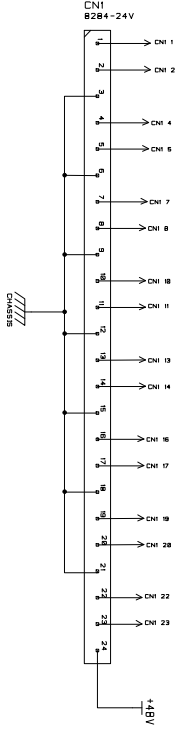

SOUNDCRAFT OWNS THE COPYRIGHT OF THIS DRAWING WHICH IS NOT TO BE A THIRD PARTY WITHOUT WRITTEN PERMISSION.

DRN: ML  
DATE 03-12-99

SOUNDCRAFT INDUSTRIES LTD.  
HARMAN INT. CRANBORNE HOUSE.  
CRANBORNE ROAD.  
POTTERS BAR, IN.  
TEL: 01899 535000  
FAX: 01753 550482

TITLE SPIRIT PRO REARCONN BOARD  
DRG NO. ED4024

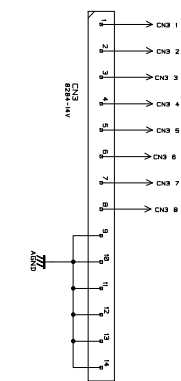
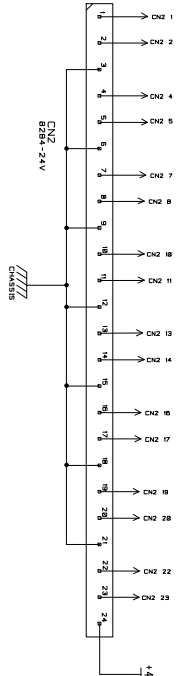
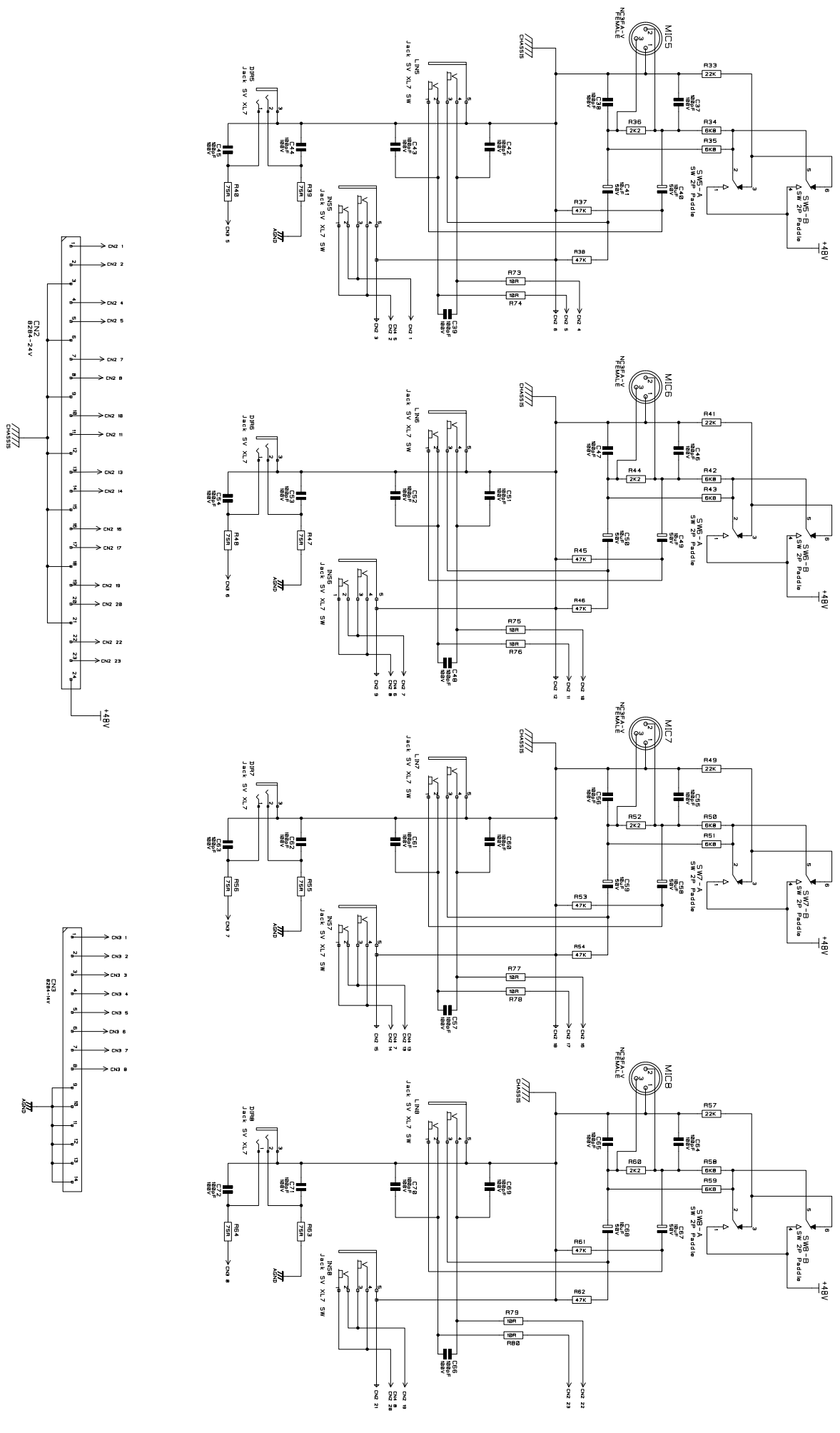

NOTES

SOUNDCRAFT OWNS THE COPYRIGHT OF THIS DRAWING WHICH IS NOT TO BE A THIRD PARTY WITHOUT WRITTEN PERMISSION.

DRN. ML

DATE 03-12-99

SOUNDCRAFT INDUSTRIES LTD.  
HARMAN INT. HOUSE,  
CRANBORNE ROAD,  
POTTERS BAR, IN.  
TELE: 01895 535000  
FAX: 01753 550482

TITLE SPIRIT PRO REARCONN BOARD

DRG NO. ED4024



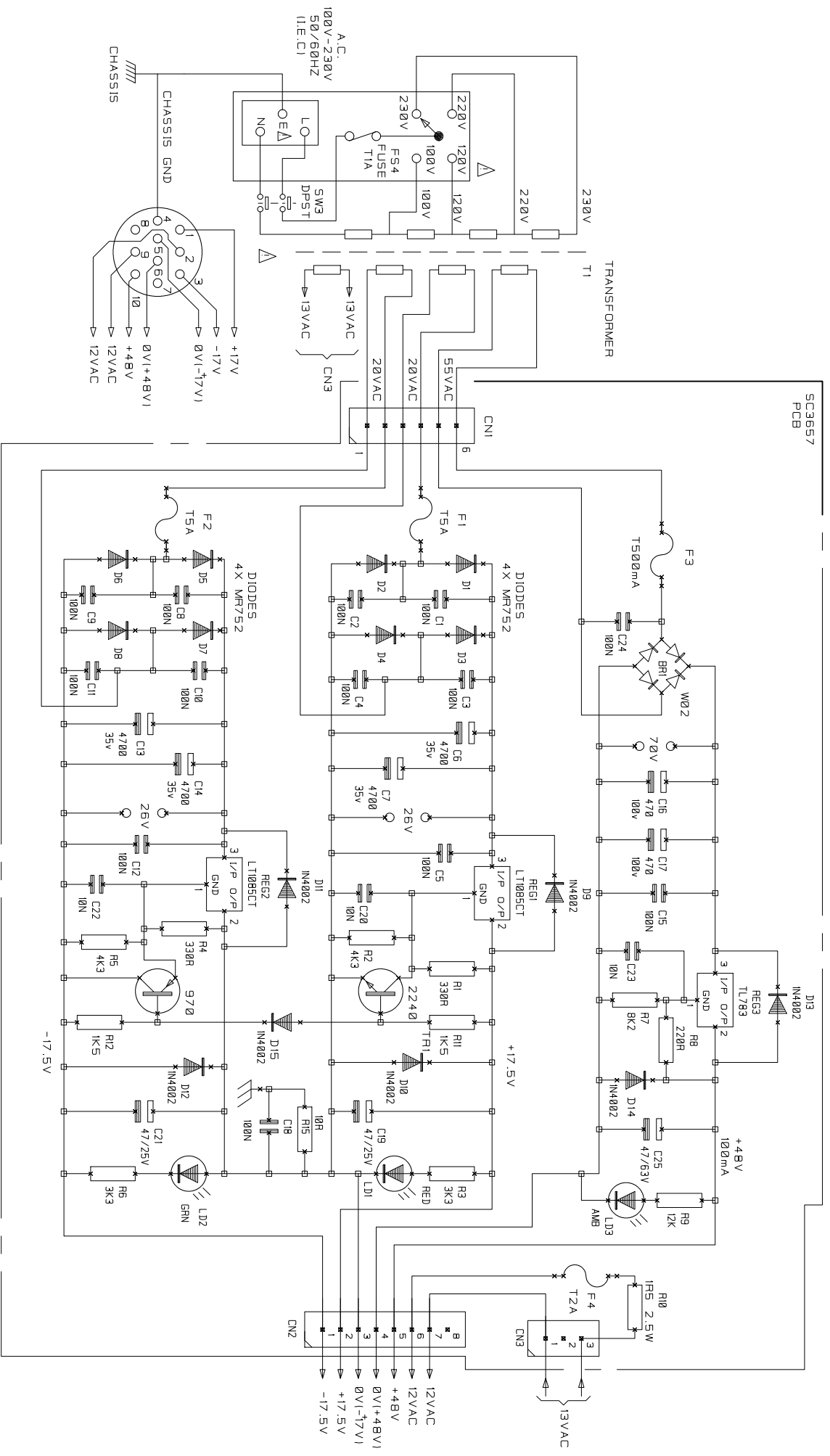

NOTES  
ALL VOLTAGES MEASURED AT NOMINAL MAINS INPUT, NO LOAD.

DRN: GH8  
TITLE: DCP200 PSU

DRG NO. ED 3657

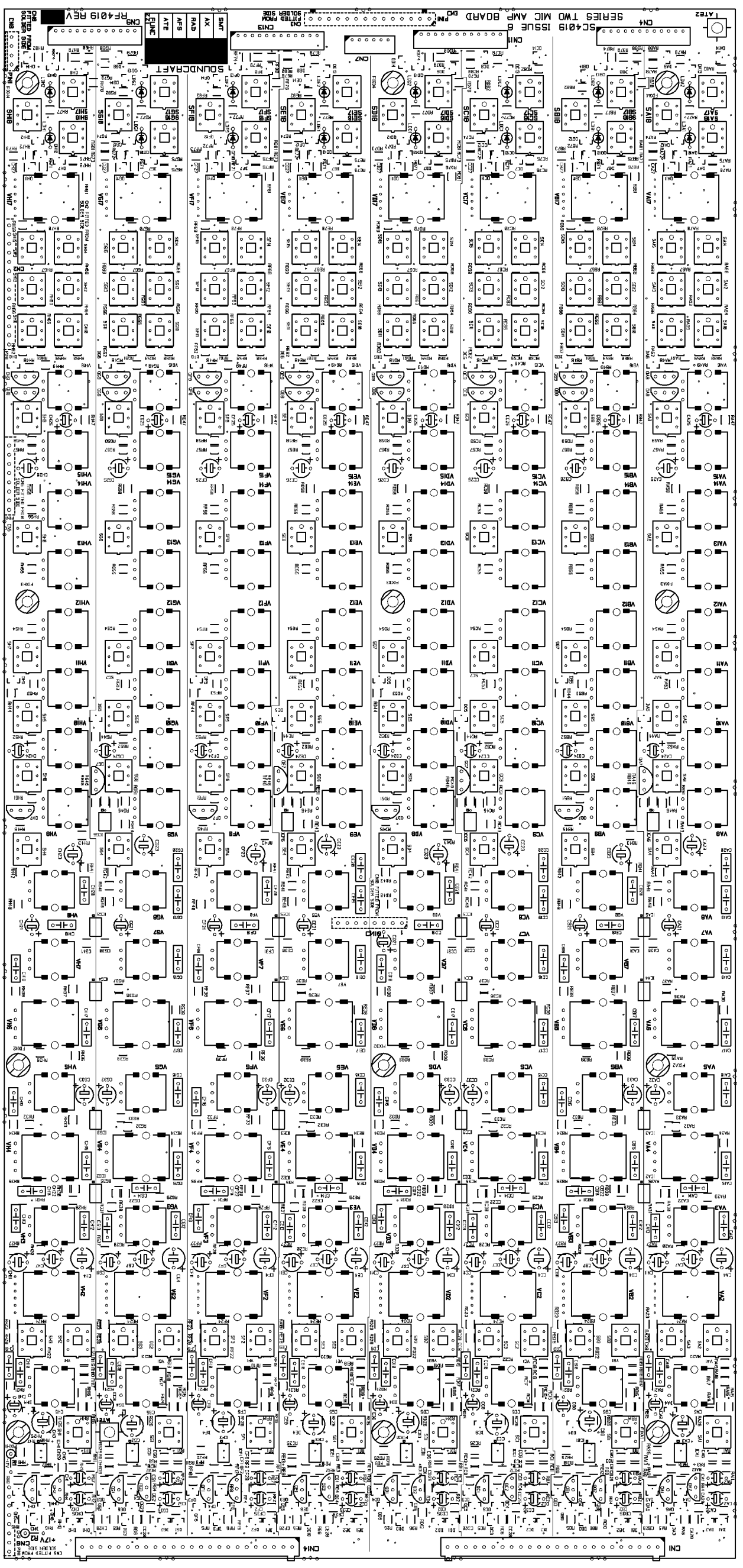

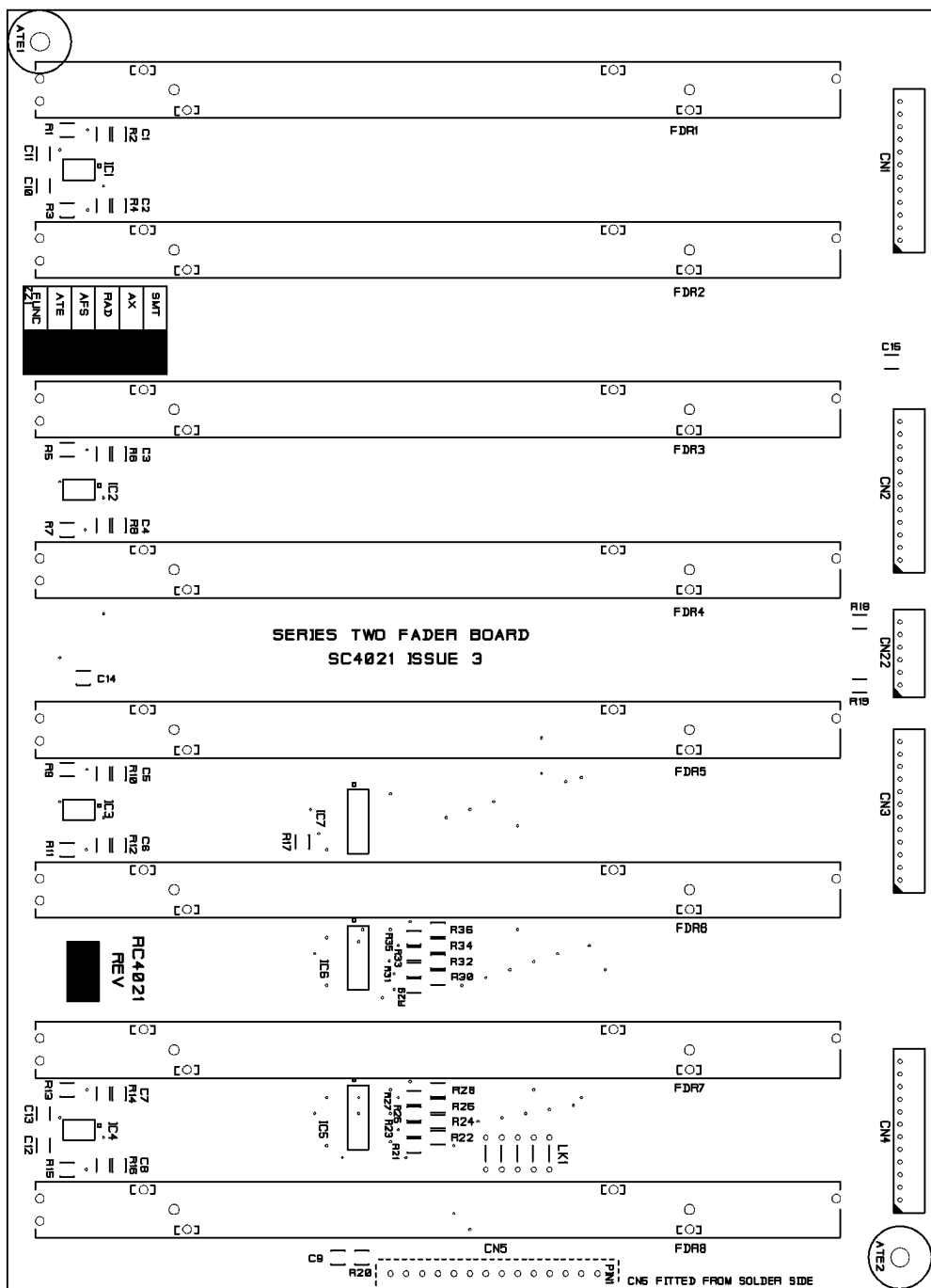



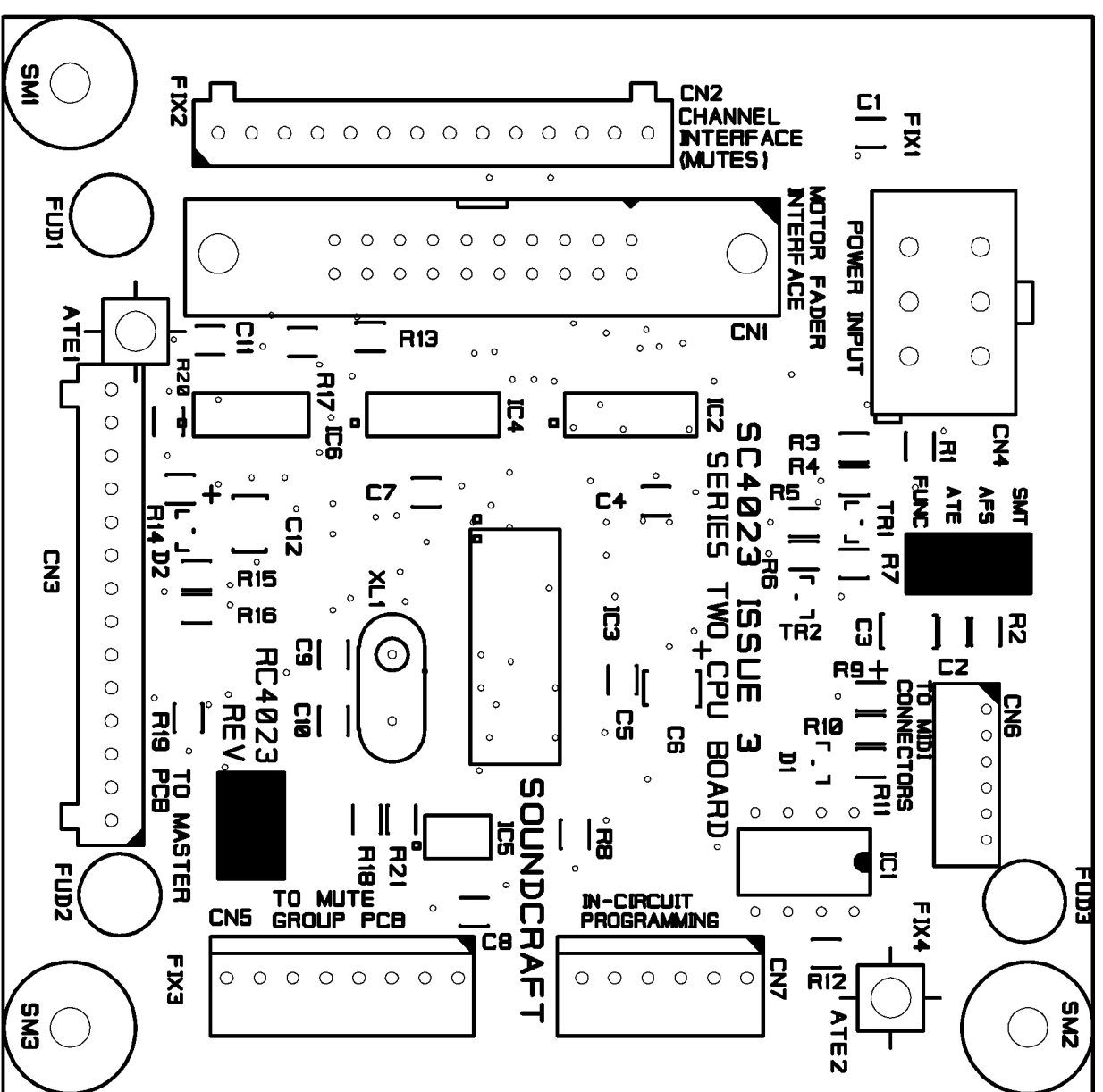



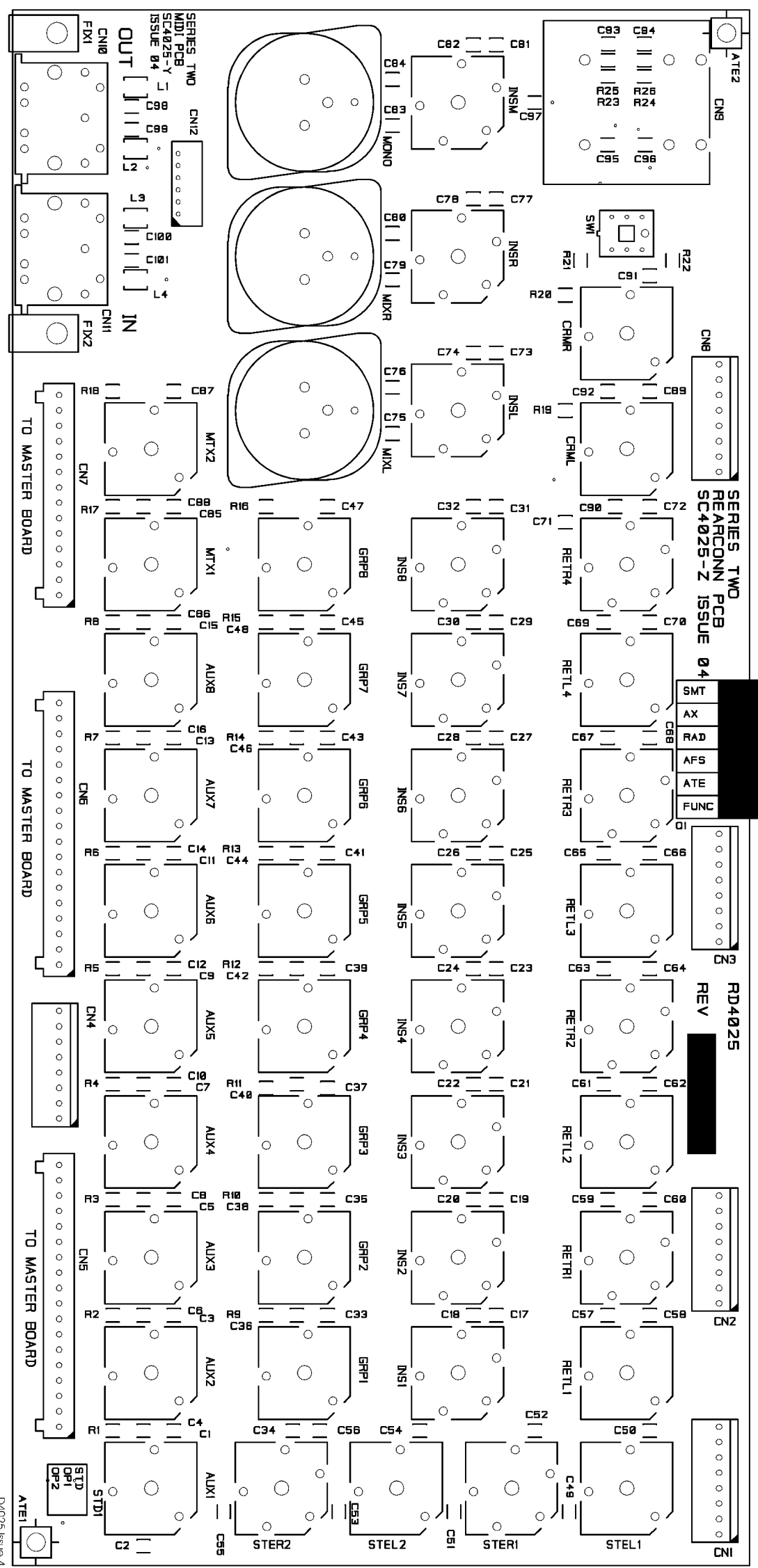

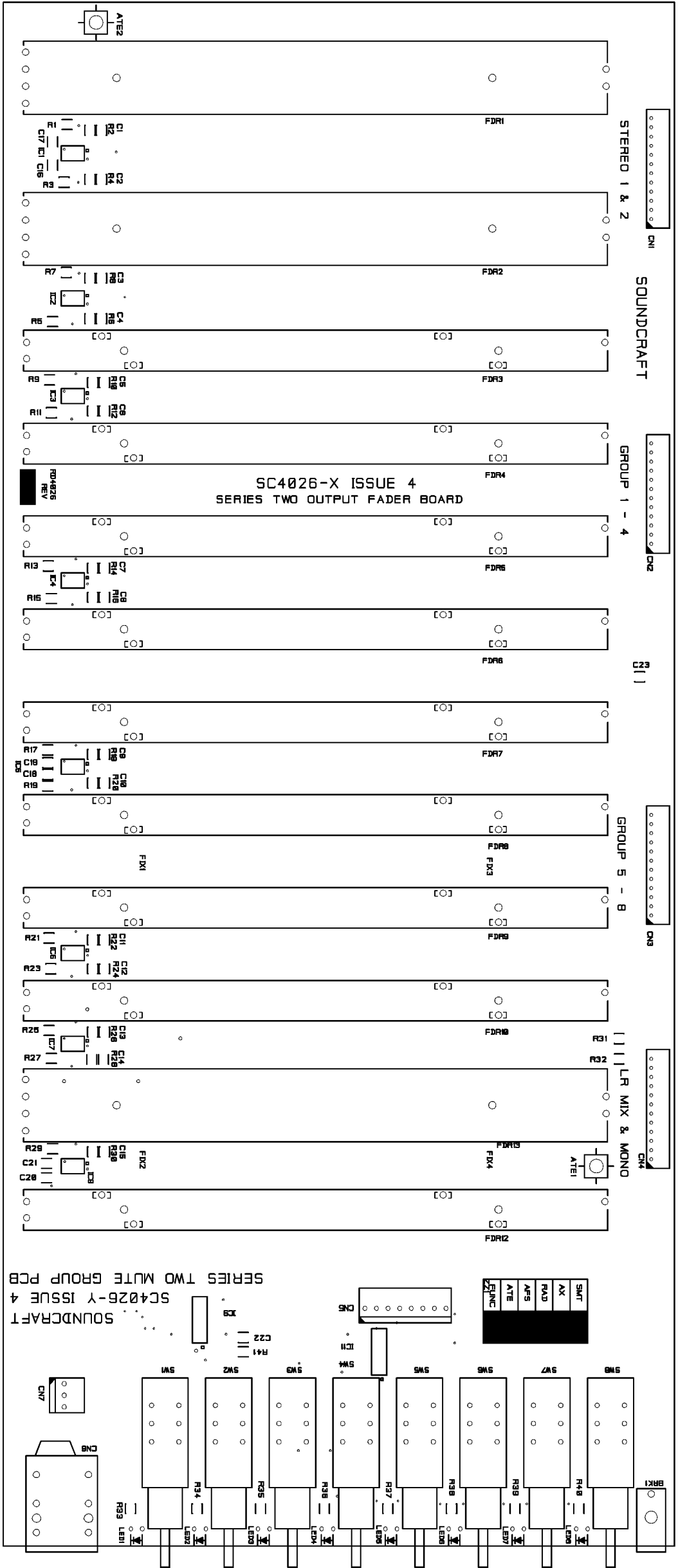



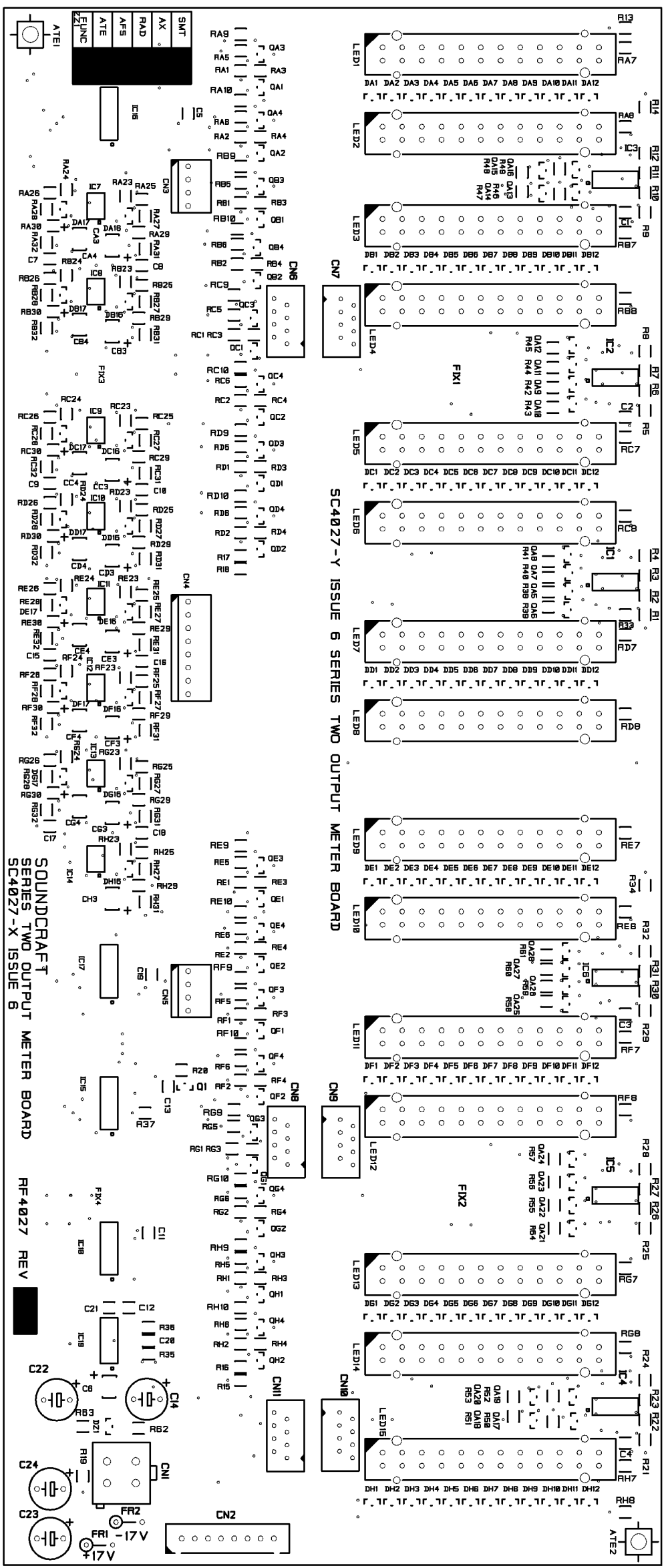

SOUND CRAFT  
 SERIES TWO OUTPUT METER BOARD  
 SC4027-X ISSUE 6

RF4027 REV

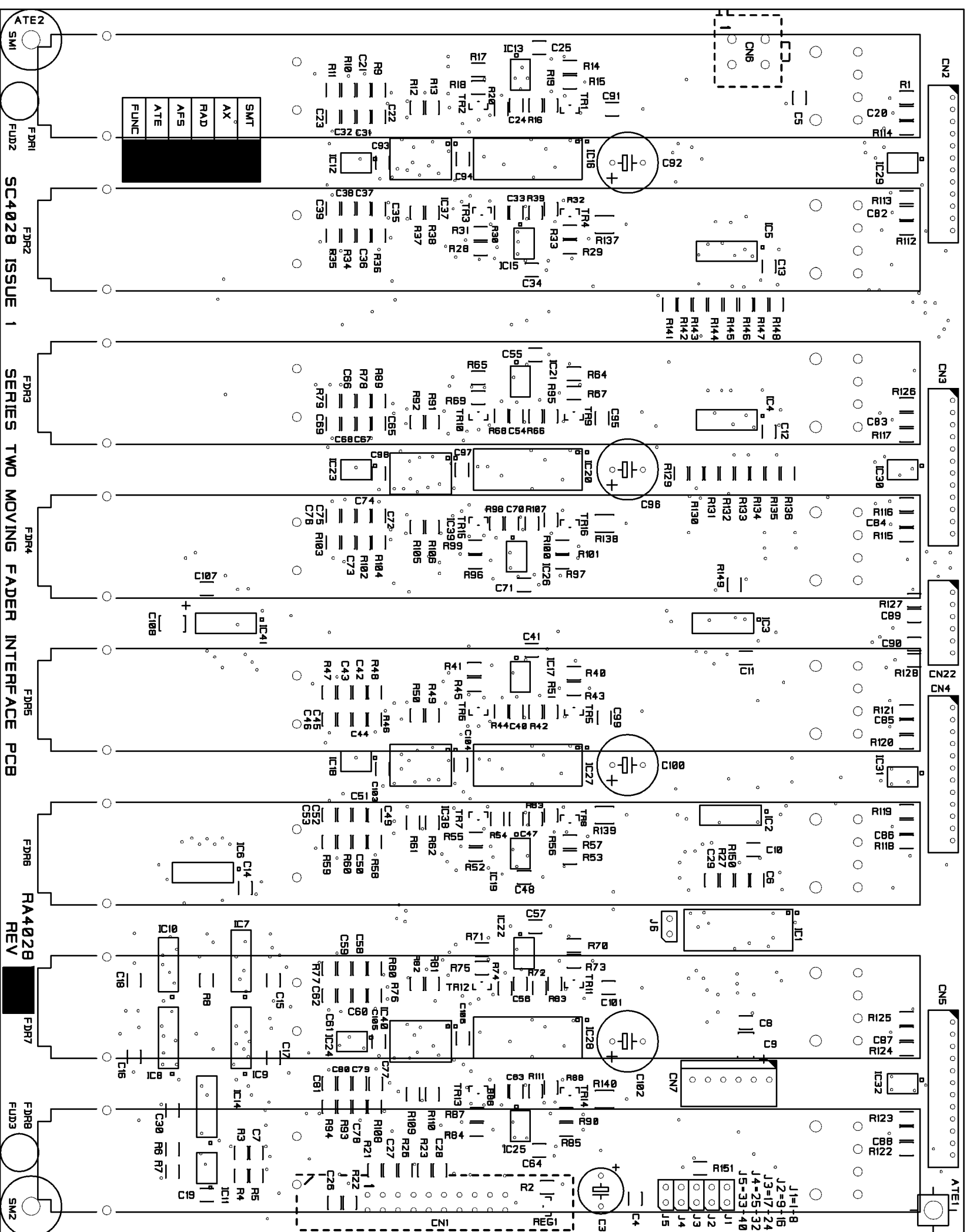

SC4028 ISSUE 1  
 SERIES TWO MOVING FADER INTERFACE PCB

RA4028  
 REV

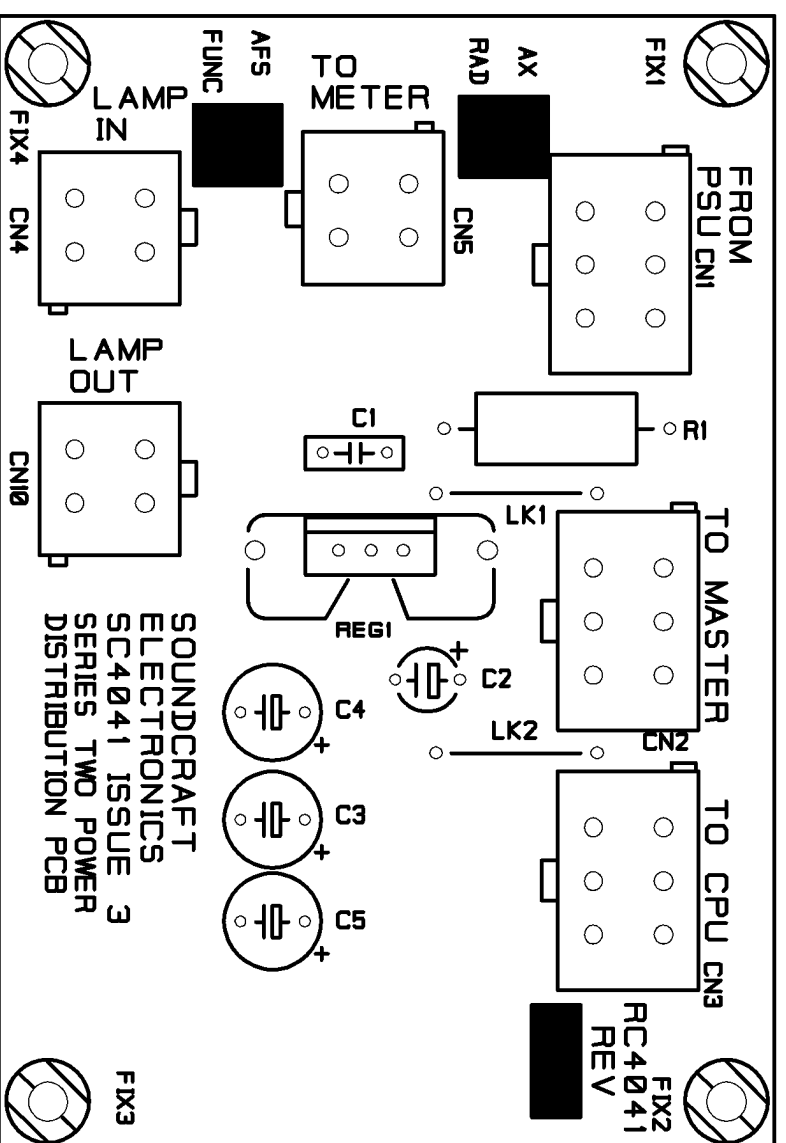

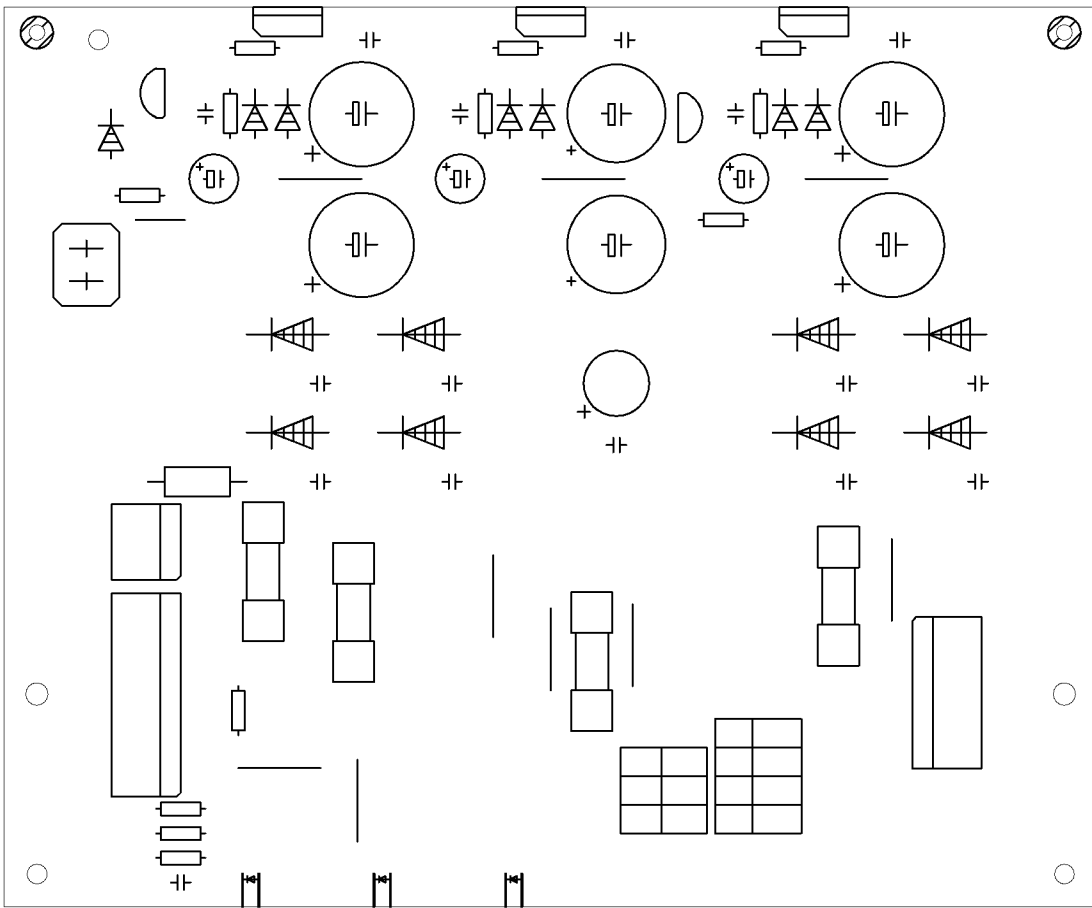

**Series TWO**

**7**

**Spare Parts**



---

## CONTENTS

<b>CONSOLES</b>	<b>7.5</b>
24I/P CONSOLE	RW5594..... 7.5
32I/P CONSOLE	RW5595..... 7.6
40I/P CONSOLE	RW5596..... 7.7
<b>MAIN ASSEMBLIES</b>	<b>7.9</b>
I/P RR CON PCB ASSY	RB4024..... 7.9
FADER I/P PCB ASSY	RC4021..... 7.11
CPU PCB ASSY	RC4023..... 7.11
PSU DIST PCB ASSY	RC4041..... 7.11
MST/MIDI RR PCB ASS	RD4025..... 7.12
O/P FDR PCB ASSY	RD4026..... 7.12
AUDIO I/P PCB ASSY	RE4019..... 7.12
MASTER PCB ASSY	RF4020..... 7.13
I/P MTR PCB ASSY	RF4022..... 7.18
O/P MTR PCB ASSY	RF4027..... 7.19
<b>SWITCH TOPS, FADER TOPS AND KNOBS</b>	<b>7.20</b>
<b>FADERS</b>	<b>7.21</b>
<b>PCBS</b>	<b>7.22</b>
FADER I/P SM ASSY	RC4021A-SM..... 7.22
CPU PCB SM ASSY	RC4023A-SM..... 7.22
MST/MIDI RR SM ASSY	RD4025A-SM..... 7.23
O/P FDR PCB SM ASSY	RD4026A-SM..... 7.24
AUDIO I/P SM ASSY	RE4019A-SM..... 7.25
MASTER PCB SM ASSY	RF4020A-SM..... 7.26
I/P MTR PCB SM ASSY	RF4022A-SM..... 7.37
O/P MTR PCB SM ASSY	RF4027A-SM..... 7.38
<b>MISCELLANEOUS HARDWARE</b>	<b>7.41</b>





---

## CONSOLES

### 24I/P CONSOLE

#### Description

12WY LED LENS  
S/THROW 2-PRT FDR KNOB-BLU/I93  
SHINY 2-PRT FDR KNOB-LT BLUE  
SHINY 2-PRT FDR KNOB-RED  
SHINY 2-PRT FDR KNOB-WHITE  
SHINY 2-PRT FDR KNOB-YELLOW  
SHINY 2-PRT FDR KNOB-BLACK  
11MM SERIES TWO KNOB GRY/RED  
11MM SERIES TWO KNOB GRY/GRY  
11MM SERIES TWO KNOB GRY/BLK  
11MM SERIES TWO LNOB GRY/GRN  
11MM SERIES TWO KNOB GRY/BLUE  
11MM SERIES TWO KNOB GRY/YEL  
SPIRIT FOLIO EXT PUSH BTN  
SERIES TWO SWITCH CAP GREY  
FFC 8WY 1.25 FLEXISTRIP-50MM  
CABLE TIE BASE 19X19MM  
M3X6MM PAN POZI BLK SCREW  
M4X10MM PAN POZI STL SCR BLACK  
M3X8MM CSK POZI SCREW BLACK  
M8X45MM CSK SKT SCRWB LCK  
M4X8MM PAN POZI SCRWB LCK  
NO4X3/8" PAN POZI S/T BLK SCRWB  
M4X10MM MUSHROOM HD PN PZ BLK  
M4X8MM CSK POZI ZINC  
M3X5 CSK POZI BLK TRUNCATED SC  
M3X10MM PAN POZI SCR BLK  
M3X6 PN PZI W/CAPT WASHER ZNC  
M3 NYLON INSERT NUT  
M4 FULL NUT  
NUT(PART OF FH0773&FH0786)  
M3 S/PROOF WASHER  
M4 S/PROOF WASHER  
WASHER(PART OF FH0773&FH0786)  
M3X20MM TAPPED PILLAR  
M4X9.53 TAPPED SPACER NYLON HE  
SERIES TWO 24CH O/B RREAR CVR  
SERIES TWO(PH2)24CH RR CON PNL  
SERIES TWO 24CH CROSSMEMBER  
SERIES TWO(PH2)MAIN SUPPORT  
SERIES TWO(PH2)24CH BASE PNL  
SERIES TWO(PH2)SIDE PLATE LH  
SERIES TWO(PH2)SIDE PLATE RH  
SERIES TWO 24CH FRONT PNL  
SERIES TWO 24CH MTR PNL  
SERIES TWO 24CH SCRIBBLE STRIP  
SERIES TWO DISPLAY WINDOW  
SERIES TWO 24CH ARMREST  
SERIES TWO SIDE TRIM LH  
SERIES TWO SIDE TRIM RH  
SERIES TWO I/P RR CON PCB ASSY  
SERIES TWO FADER I/P PCB ASSY  
SERIES TWO CPU PCB ASSY  
SERIES TWO PSU DIST PCB ASSY  
SERIES TWO MST/MIDI RR PCB ASSY  
SERIES TWO O/P FDR PCB ASSY  
SERIES TWO AUDIO I/P PCB ASSY  
SERIES TWO MASTER PCB ASSY  
SERIES TWO I/P MTR PCB ASSY  
SERIES TWO O/P MTR PCB ASSY  
SM12 I/P XLR WFM  
SERIES TWO 4WY LINK WFM  
SERIES TWO 14WY LOOM-300MM  
SPIRIT FX16 14WY LOOM(MI5181)  
SPIRIT FX16 24WY LOOM(MI5182)  
2MM 12WY CRIMP/CRIMP 90MM WFM  
2MM 6WY CRIMP/CRIMP 90MM WFM  
SERIES TWO 18WY LOOM-560MM-MI5  
SERIES TWO 24CH SOLO BUS LM MI

### RW5594

#### Part Number

JD0396  
KA0226  
KA0343  
KA0345  
KA0346  
KA0347  
KA0348  
KA0373  
KA0374  
KA0375  
KA0376  
KA0377  
KA0378  
KB1656  
KB2260  
LC0281  
LF0567  
NA0084  
NA0146  
NA0210  
NA0227  
NA0241  
NA0249  
NA0291  
NA0296  
NA0328  
NA0394  
NA0401  
NB0113  
NB0154  
NB0176  
NC0221  
NC0248  
NC0296  
ND0321  
ND0400  
PC1465-01  
PC1474-01  
PF0688-02  
PF0692-01  
PH1510-01  
PH1513-01  
PH1514-01  
PJ1603-02  
PJ1605-02  
PK2590-01  
PK2594-01  
PM1559TG-03  
PM1562TG-03  
PM1563TG-03  
RB4024  
RC4021  
RC4023  
RC4041  
RD4025  
RD4026  
RE4019  
RF4020  
RF4022  
RF4027  
RV3128  
RV3687-140  
RV3761-14-300  
RV3761-14-480  
RV3762-24-110  
RV4030  
RV4031  
RV4050-18-560  
RV4051

SERIES TWO 14WY 24CH M/LM MI52  
 SERIES TWO 8WY 24CH M/LM MI523  
 2MM 6WY CRIMP/CRIMP 640MM  
 SERIES TWO 14WY CPU MST LOOM-M  
 SERIES TWO MTR TO RR CON LOOM-  
 SERIES TWO I/P TO MTR LOOM-MI5  
 SERIES TWO 24CH MTR LM MI5237  
 SERIES TWO SRC WFM  
 SERIES TWO MST/RRCON WFM 100MM  
 SERIES TWO MST/RRCON WFM 250MM  
 SERIES TWO MST/MTR WFM 500MM  
 SERIES TWO PWR WFM 475MM  
 SERIES TWO 24CH LITTLELITE WFM  
 SERIES TWO PWR WFM  
 SERIES TWO 24CH FDR LM MI5240  
 SERIES TWO H/PHONE WFM  
 SERIES TWO 24CH DUSTCOVER  
 RICHO SCREW ON PLASTIC FEET

RV4054  
 RV4056  
 RV4061  
 RV4065  
 RV4066-8-130  
 RV4066-8-300  
 RV4068  
 RV4071  
 RV4072-100  
 RV4072-250  
 RV4073-500  
 RV4074-475  
 RV4075  
 RV4078  
 RV4079  
 RV4088-500  
 TZ2431  
 ZZ2541

## 32I/P CONSOLE

### Description

12WY LED LENS  
 S/THROW 2-PRT FDR KNOB-BLU/I93  
 SHINY 2-PRT FDR KNOB-LT BLUE  
 SHINY 2-PRT FDR KNOB-RED  
 SHINY 2-PRT FDR KNOB-WHITE  
 SHINY 2-PRT FDR KNOB-YELLOW  
 SHINY 2-PRT FDR KNOB-BLACK  
 11MM SERIES TWO KNOB GRY/RED  
 11MM SERIES TWO KNOB GRY/GRY  
 11MM SERIES TWO KNOB GRY/BLK  
 11MM SERIES TWO LNOB GRY/GRN  
 11MM SERIES TWO KNOB GRY/BLUE  
 11MM SERIES TWO KNOB GRY/YEL  
 SPIRIT FOLIO EXT PUSH BTN  
 SERIES TWO SWITCH CAP GREY  
 FFC 8WY 1.25 FLEXISTRIP-50MM  
 CABLE TIE BASE 19X19MM  
 M3X6MM PAN POZI BLK SCREW  
 M4X10MM PAN POZI STL SCR BLACK  
 M3X8MM CSK POZI SCREW BLACK  
 M4X8MM PAN POZI SCRW BLCK  
 NO4X3/8" PAN POZI S/T BLK SCRW  
 M5X8MM PAN HEAD SCR ZINC  
 M4X10MM MUSHROOM HD PN PZ BLK  
 M4X8MM CSK POZI ZINC  
 M3X5 CSK POZI BLK TRUNCATED SC  
 M3X10MM PAN POZI SCR BLK  
 M3X6 PN PZI W/CAPT WASHER ZNC  
 M2.5X6 PAN POZI SCREW BLK  
 M3 NYLON INSERT NUT  
 M4 FULL NUT  
 NUT(PART OF FH0773&FH0786)  
 M3 S/PROOF WASHER  
 M4 S/PROOF WASHER  
 WASHER(PART OF FH0773&FH0786)  
 M3X20MM TAPPED PILLAR  
 M4X9.53 TAPPED SPACER NYLON HE  
 SERIES TWO 32CH O/B REAR CVR  
 SERIES TWO(PH2)32CH RR CON PNL  
 SERIES TWO 32CH CROSSMEMBER  
 SERIES TWO(PH2)MAIN SUPPORT  
 SERIES TWO(PH2)32CH BASE PNL  
 SERIES TWO(PH2)SIDE PLATE LH  
 SERIES TWO(PH2)SIDE PLATE RH  
 SERIES TWO 32CH FRONT PNL  
 SERIES TWO 32CH MTR PNL  
 SERIES TWO 32CH SCRIBBLE STRIP  
 SERIES TWO DISPLAY WINDOW  
 SERIES TWO 32CH ARMREST  
 SERIES TWO SIDE TRIM LH  
 SERIES TWO SIDE TRIM RH  
 SERIES TWO I/P RR CON PCB ASSY  
 SERIES TWO FADER I/P PCB ASSY  
 SERIES TWO CPU PCB ASSY

## RW5595

### Part Number

JD0396  
 KA0226  
 KA0343  
 KA0345  
 KA0346  
 KA0347  
 KA0348  
 KA0373  
 KA0374  
 KA0375  
 KA0376  
 KA0377  
 KA0378  
 KB1656  
 KB2260  
 LC0281  
 LF0567  
 NA0084  
 NA0146  
 NA0210  
 NA0241  
 NA0249  
 NA0277  
 NA0291  
 NA0296  
 NA0328  
 NA0394  
 NA0401  
 NA0429  
 NB0113  
 NB0154  
 NB0176  
 NC0221  
 NC0248  
 NC0296  
 ND0321  
 ND0400  
 PC1466-01  
 PC1475-01  
 PF0686-03  
 PF0692-01  
 PH1511-01  
 PH1513-01  
 PH1514-01  
 PJ1593-03  
 PJ1595-03  
 PK2591-01  
 PK2594-01  
 PM1560TG-03  
 PM1562TG-03  
 PM1563TG-03  
 RB4024  
 RC4021  
 RC4023

SERIES TWO PSU DIST PCB ASSY	RC4041
SERIES TWO MST/MIDI RR PCB ASS	RD4025
SERIES TWO O/P FDR PCB ASSY	RD4026
SERIES TWO AUDIO I/P PCB ASSY	RE4019
SERIES TWO MASTER PCB ASSY	RF4020
SERIES TWO I/P MTR PCB ASSY	RF4022
SERIES TWO O/P MTR PCB ASSY	RF4027
SM12 I/P XLR WFM	RV3128
SERIES TWO 4WY LINK WFM	RV3687-140
SERIES TWO 14WY LOOM-300MM	RV3761-14-300
SPIRIT FX16 14WY LOOM(MI5181)	RV3761-14-480
SPIRIT FX16 24WY LOOM(MI5182)	RV3762-24-110
2MM 12WY CRIMP/CRIMP 90MM WFM	RV4030
2MM 6WY CRIMP/CRIMP 90MM WFM	RV4031
SERIES TWO 14WY M/LM MI5243	RV4048
SERIES TWO 8WY M/LM MI5244	RV4049
SERIES TWO 18WY LOOM-560MM-MI5	RV4050-18-560
SERIES TWO 32CH SOLO BUS LM MI	RV4052
2MM 6WY CRIMP/CRIMP 640MM	RV4061
SERIES TWO 14WY CPU MST LOOM-M	RV4065
SERIES TWO MTR TO RR CON LOOM-	RV4066-8-130
SERIES TWO I/P TO MTR LOOM-MI5	RV4066-8-300
SERIES TWO 32CH MTR LM MI5238	RV4069
SERIES TWO SRC WFM	RV4071
SERIES TWO MST/RRCON WFM 100MM	RV4072-100
SERIES TWO MST/RRCON WFM 250MM	RV4072-250
SERIES TWO MST/MTR WFM 500MM	RV4073-500
SERIES TWO PWR WFM 475MM	RV4074-475
SERIES TWO 32CH LITTLELITE WFM	RV4076
SERIES TWO PWR WFM	RV4078
SERIES TWO 32CH FDR LM MI5241	RV4080
SERIES TWO H/PHONE WFM	RV4088-500
SERIES TWO 32CH DUSTCOVER	TZ2432
RICHO SCREW ON PLASTIC FEET	ZZ2541

## 40I/P CONSOLE

### Description

12WY LED LENS  
 S/THROW 2-PRT FDR KNOB-BLU/193  
 SHINY 2-PRT FDR KNOB-LT BLUE  
 SHINY 2-PRT FDR KNOB-RED  
 SHINY 2-PRT FDR KNOB-WHITE  
 SHINY 2-PRT FDR KNOB-YELLOW  
 SHINY 2-PRT FDR KNOB-BLACK  
 11MM SERIES TWO KNOB GRY/RED  
 11MM SERIES TWO KNOB GRY/GRY  
 11MM SERIES TWO KNOB GRY/BLK  
 11MM SERIES TWO LNOB GRY/GRN  
 11MM SERIES TWO KNOB GRY/BLUE  
 11MM SERIES TWO KNOB GRY/YEL  
 SPIRIT FOLIO EXT PUSH BTN  
 SERIES TWO SWITCH CAP GREY  
 FFC 8WY 1.25 FLEXISTRIP-50MM  
 CABLE TIE BASE 19X19MM  
 M3X6MM PAN POZI BLK SCREW  
 M3X8MM CSK POZI SCREW BLACK  
 M4X8MM PAN POZI SCRWBK  
 NO4X3/8" PAN POZI S/T BLK SCRWB  
 M5X8MM PAN HEAD SCR ZINC  
 M4X10MM MUSHROOM HD PN PZ BLK  
 M4X8MM CSK POZI ZINC  
 M3X5 CSK POZI BLK TRUNCATED SC  
 NO10-14X1/2" PAN POZI PLASTITE  
 M3X10MM PAN POZI SCR BLK  
 M3X6 PN PZI W/CAPT WASHER ZNC  
 M2.5X6 PAN POZI SCREW BLK  
 M3 NYLON INSERT NUT  
 M4 BARB NUT  
 NUT(PART OF FH0773&FH0786)  
 M3 S/PROOF WASHER  
 M4 S/PROOF WASHER  
 WASHER(PART OF FH0773&FH0786)  
 M3X20MM TAPPED PILLAR  
 M4X9.53 TAPPED SPACER NYLON HE  
 SERIES TWO 40CH O/B REAR CVR

## RW5596

### Part Number

JD0396  
 KA0226  
 KA0343  
 KA0345  
 KA0346  
 KA0347  
 KA0348  
 KA0373  
 KA0374  
 KA0375  
 KA0376  
 KA0377  
 KA0378  
 KB1656  
 KB2260  
 LC0281  
 LF0567  
 NA0084  
 NA0210  
 NA0241  
 NA0249  
 NA0277  
 NA0291  
 NA0296  
 NA0328  
 NA0346  
 NA0394  
 NA0401  
 NA0429  
 NB0113  
 NB0168  
 NB0176  
 NC0221  
 NC0248  
 NC0296  
 ND0321  
 ND0400  
 PCI467-01

SERIES TWO(PH2)40CH RR CON NL	PC1476-01
SERIES TWO 40CH CROSSMEMBER	PF0689-02
SERIES TWO(PH2)MAIN SUPPORT	PF0692-01
SERIES TWO(PH2)40CH BASE PNL	PH1512-01
SERIES TWO(PH2)SIDE PLATE LH	PH1513-01
SERIES TWO(PH2)SIDE PLATE RH	PH1514-01
SERIES TWO 40CH FRONT PNL	PJ1606-02
SERIES TWO 40CH MTR PNL	PJ1608-02
SERIES TWO 40CH SCRIBBLE STRIP	PK2592-01
SERIES TWO DISPLAY WINDOW	PK2594-01
SERIES TWO 40CH ARMREST	PM1561TG-03
SERIES TWO SIDE TRIM LH	PM1562TG-03
SERIES TWO SIDE TRIM RH	PM1563TG-03
SERIES TWO I/P RR CON PCB ASSY	RB4024
SERIES TWO FADER I/P PCB ASSY	RC4021
SERIES TWO CPU PCB ASSY	RC4023
SERIES TWO PSU DIST PCB ASSY	RC4041
SERIES TWO MST/MIDI RR PCB ASS	RD4025
SERIES TWO O/P FDR PCB ASSY	RD4026
SERIES TWO AUDIO I/P PCB ASSY	RE4019
SERIES TWO MASTER PCB ASSY	RF4020
SERIES TWO I/P MTR PCB ASSY	RF4022
SERIES TWO O/P MTR PCB ASSY	RF4027
SM12 I/P XLR WFM	RV3128
SERIES TWO 4WY LINK WFM	RV3687-140
SERIES TWO 14WY LOOM-300MM	RV3761-14-300
SPIRIT FX16 14WY LOOM(M15181)	RV3761-14-480
SPIRIT FX16 24WY LOOM(M15182)	RV3762-24-110
2MM 12WY CRIMP/CRIMP 90MM WFM	RV4030
2MM 6WY CRIMP/CRIMP 90MM WFM	RV4031
SERIES TWO 18WY LOOM-560MM-M15	RV4050-18-560
SERIES TWO 40CH SOLO BUS LM MI	RV4053
SERIES TWO 14WY 40CH M/LM MI52	RV4055
SERIES TWO 8WY 40CH M/LM MI523	RV4057
2MM 6WY CRIMP/CRIMP 640MM	RV4061
SERIES TWO 14WY CPU MST LOOM-M	RV4065
SERIES TWO MTR TO RR CON LOOM-	RV4066-8-130
SERIES TWO I/P TO MTR LOOM-MI5	RV4066-8-300
SERIES TWO 40CH MTR LM MI5239	RV4070
SERIES TWO SRC WFM	RV4071
SERIES TWO MST/RRCON WFM 100MM	RV4072-100
SERIES TWO MST/RRCON WFM 250MM	RV4072-250
SERIES TWO MST/MTR WFM 500MM	RV4073-500
SERIES TWO PWR WFM 475MM	RV4074-475
SERIES TWO 40CH LITTLELITE WFM	RV4077
SERIES TWO PWR WFM	RV4078
SERIES TWO 40CH FDR LM MI5242	RV4081
SERIES TWO H/PHONE WFM	RV4088-500
SERIES TWO 40CH DUSTCOVER	TZ2433
RICHO SCREW ON PLASTIC FEET	ZZ2541

## MAIN ASSEMBLIES

### I/P RR CON PCB ASSY

Ident	Description	Part Number
pcb	SERIES TWO I/P RR CON PCB	SC4024-02
C1	C/C 0.2" TAPED 100V 100PF(N10)	CA0006
C2	C/C 0.2" TAPED 100V 100PF(N10)	CA0006
C3	C/C 0.2" TAPED 100V 100PF(N10)	CA0006
C4	VERT ELEC TPD 10UF/50V SSP	CE0474
C5	VERT ELEC TPD 10UF/50V SSP	CE0474
C6	C/C 0.2" TAPED 100V 100PF(N10)	CA0006
C7	C/C 0.2" TAPED 100V 100PF(N10)	CA0006
C8	C/C 0.2" TAPED 100V 100PF(N10)	CA0006
C9	C/C 0.2" TAPED 100V 100PF(N10)	CA0006
C10	C/C 0.2" TAPED 100V 100PF(N10)	CA0006
C11	C/C 0.2" TAPED 100V 100PF(N10)	CA0006
C12	C/C 0.2" TAPED 100V 100PF(N10)	CA0006
C13	VERT ELEC TPD 10UF/50V SSP	CE0474
C14	VERT ELEC TPD 10UF/50V SSP	CE0474
C15	C/C 0.2" TAPED 100V 100PF(N10)	CA0006
C16	C/C 0.2" TAPED 100V 100PF(N10)	CA0006
C17	C/C 0.2" TAPED 100V 100PF(N10)	CA0006
C18	C/C 0.2" TAPED 100V 100PF(N10)	CA0006
C19	C/C 0.2" TAPED 100V 100PF(N10)	CA0006
C20	C/C 0.2" TAPED 100V 100PF(N10)	CA0006
C21	C/C 0.2" TAPED 100V 100PF(N10)	CA0006
C22	VERT ELEC TPD 10UF/50V SSP	CE0474
C23	VERT ELEC TPD 10UF/50V SSP	CE0474
C24	C/C 0.2" TAPED 100V 100PF(N10)	CA0006
C25	C/C 0.2" TAPED 100V 100PF(N10)	CA0006
C26	C/C 0.2" TAPED 100V 100PF(N10)	CA0006
C27	C/C 0.2" TAPED 100V 100PF(N10)	CA0006
C28	C/C 0.2" TAPED 100V 100PF(N10)	CA0006
C29	C/C 0.2" TAPED 100V 100PF(N10)	CA0006
C30	C/C 0.2" TAPED 100V 100PF(N10)	CA0006
C31	VERT ELEC TPD 10UF/50V SSP	CE0474
C32	VERT ELEC TPD 10UF/50V SSP	CE0474
C33	C/C 0.2" TAPED 100V 100PF(N10)	CA0006
C34	C/C 0.2" TAPED 100V 100PF(N10)	CA0006
C35	C/C 0.2" TAPED 100V 100PF(N10)	CA0006
C36	C/C 0.2" TAPED 100V 100PF(N10)	CA0006
C37	C/C 0.2" TAPED 100V 100PF(N10)	CA0006
C38	C/C 0.2" TAPED 100V 100PF(N10)	CA0006
C39	C/C 0.2" TAPED 100V 100PF(N10)	CA0006
C40	VERT ELEC TPD 10UF/50V SSP	CE0474
C41	VERT ELEC TPD 10UF/50V SSP	CE0474
C42	C/C 0.2" TAPED 100V 100PF(N10)	CA0006
C43	C/C 0.2" TAPED 100V 100PF(N10)	CA0006
C44	C/C 0.2" TAPED 100V 100PF(N10)	CA0006
C45	C/C 0.2" TAPED 100V 100PF(N10)	CA0006
C46	C/C 0.2" TAPED 100V 100PF(N10)	CA0006
C47	C/C 0.2" TAPED 100V 100PF(N10)	CA0006
C48	C/C 0.2" TAPED 100V 100PF(N10)	CA0006
C49	VERT ELEC TPD 10UF/50V SSP	CE0474
C50	VERT ELEC TPD 10UF/50V SSP	CE0474
C51	C/C 0.2" TAPED 100V 100PF(N10)	CA0006
C52	C/C 0.2" TAPED 100V 100PF(N10)	CA0006
C53	C/C 0.2" TAPED 100V 100PF(N10)	CA0006
C54	C/C 0.2" TAPED 100V 100PF(N10)	CA0006
C55	C/C 0.2" TAPED 100V 100PF(N10)	CA0006
C56	C/C 0.2" TAPED 100V 100PF(N10)	CA0006
C57	C/C 0.2" TAPED 100V 100PF(N10)	CA0006
C58	VERT ELEC TPD 10UF/50V SSP	CE0474
C59	VERT ELEC TPD 10UF/50V SSP	CE0474
C60	C/C 0.2" TAPED 100V 100PF(N10)	CA0006
C61	C/C 0.2" TAPED 100V 100PF(N10)	CA0006
C62	C/C 0.2" TAPED 100V 100PF(N10)	CA0006
C63	C/C 0.2" TAPED 100V 100PF(N10)	CA0006
C64	C/C 0.2" TAPED 100V 100PF(N10)	CA0006
C65	C/C 0.2" TAPED 100V 100PF(N10)	CA0006
C66	C/C 0.2" TAPED 100V 100PF(N10)	CA0006
C67	VERT ELEC TPD 10UF/50V SSP	CE0474

### RB4024

C68	VERT ELEC TPD 10UF/50V SSP	CE0474
C69	C/C 0.2" TAPED 100V 100PF(N10)	CA0006
C70	C/C 0.2" TAPED 100V 100PF(N10)	CA0006
C71	C/C 0.2" TAPED 100V 100PF(N10)	CA0006
C72	C/C 0.2" TAPED 100V 100PF(N10)	CA0006
CN1	24WY VERT SHROUDED HDR	FF0993
CN2	24WY VERT SHROUDED HDR	FF0993
CN3	14WY VERT SHROUDED HDR	FF0991
CN4	8WY VERT SHROUDED HDR	FF0990
Jack	JCK SKT STEREO	FH0773
Jack	JACK SKT STEREO BREAK	FH0786
R1	MF 0.25W RES 2% 22K	AD0481
R2	MF 0.25W RES 2% 6K8	AD0469
R3	MF 0.25W RES 2% 6K8	AD0469
R4	MF 0.25W RES 2% 2K2	AD0457
R5	MF 0.25W RES 2% 47K	AD0489
R6	MF 0.25W RES 2% 47K	AD0489
R7	MF 0.25W RES 2% 75R	AD0422
R8	MF 0.25W RES 2% 75R	AD0422
R9	MF 0.25W RES 2% 22K	AD0481
R10	MF 0.25W RES 2% 6K8	AD0469
R11	MF 0.25W RES 2% 6K8	AD0469
R12	MF 0.25W RES 2% 2K2	AD0457
R13	MF 0.25W RES 2% 47K	AD0489
R14	MF 0.25W RES 2% 47K	AD0489
R15	MF 0.25W RES 2% 75R	AD0422
R16	MF 0.25W RES 2% 75R	AD0422
R17	MF 0.25W RES 2% 22K	AD0481
R18	MF 0.25W RES 2% 6K8	AD0469
R19	MF 0.25W RES 2% 6K8	AD0469
R20	MF 0.25W RES 2% 2K2	AD0457
R21	MF 0.25W RES 2% 47K	AD0489
R22	MF 0.25W RES 2% 47K	AD0489
R23	MF 0.25W RES 2% 75R	AD0422
R24	MF 0.25W RES 2% 75R	AD0422
R25	MF 0.25W RES 2% 22K	AD0481
R26	MF 0.25W RES 2% 6K8	AD0469
R27	MF 0.25W RES 2% 6K8	AD0469
R28	MF 0.25W RES 2% 2K2	AD0457
R29	MF 0.25W RES 2% 47K	AD0489
R30	MF 0.25W RES 2% 47K	AD0489
R31	MF 0.25W RES 2% 75R	AD0422
R32	MF 0.25W RES 2% 75R	AD0422
R33	MF 0.25W RES 2% 22K	AD0481
R34	MF 0.25W RES 2% 6K8	AD0469
R35	MF 0.25W RES 2% 6K8	AD0469
R36	MF 0.25W RES 2% 2K2	AD0457
R37	MF 0.25W RES 2% 47K	AD0489
R38	MF 0.25W RES 2% 47K	AD0489
R39	MF 0.25W RES 2% 75R	AD0422
R40	MF 0.25W RES 2% 75R	AD0422
R41	MF 0.25W RES 2% 22K	AD0481
R42	MF 0.25W RES 2% 6K8	AD0469
R43	MF 0.25W RES 2% 6K8	AD0469
R44	MF 0.25W RES 2% 2K2	AD0457
R45	MF 0.25W RES 2% 47K	AD0489
R46	MF 0.25W RES 2% 47K	AD0489
R47	MF 0.25W RES 2% 75R	AD0422
R48	MF 0.25W RES 2% 75R	AD0422
R49	MF 0.25W RES 2% 22K	AD0481
R50	MF 0.25W RES 2% 6K8	AD0469
R51	MF 0.25W RES 2% 6K8	AD0469
R52	MF 0.25W RES 2% 2K2	AD0457
R53	MF 0.25W RES 2% 47K	AD0489
R54	MF 0.25W RES 2% 47K	AD0489
R55	MF 0.25W RES 2% 75R	AD0422
R56	MF 0.25W RES 2% 75R	AD0422
R57	MF 0.25W RES 2% 22K	AD0481
R58	MF 0.25W RES 2% 6K8	AD0469
R59	MF 0.25W RES 2% 6K8	AD0469
R60	MF 0.25W RES 2% 2K2	AD0457
R61	MF 0.25W RES 2% 47K	AD0489
R62	MF 0.25W RES 2% 47K	AD0489
R63	MF 0.25W RES 2% 75R	AD0422
R64	MF 0.25W RES 2% 75R	AD0422
R65	MF 0.25W RES 2% 10R	AD0401

R66	MF 0.25W RES 2% 10R	AD0401
R67	MF 0.25W RES 2% 10R	AD0401
R68	MF 0.25W RES 2% 10R	AD0401
R69	MF 0.25W RES 2% 10R	AD0401
R70	MF 0.25W RES 2% 10R	AD0401
R71	MF 0.25W RES 2% 10R	AD0401
R72	MF 0.25W RES 2% 10R	AD0401
R73	MF 0.25W RES 2% 10R	AD0401
R74	MF 0.25W RES 2% 10R	AD0401
R75	MF 0.25W RES 2% 10R	AD0401
R76	MF 0.25W RES 2% 10R	AD0401
R77	MF 0.25W RES 2% 10R	AD0401
R78	MF 0.25W RES 2% 10R	AD0401
R79	MF 0.25W RES 2% 10R	AD0401
R80	MF 0.25W RES 2% 10R	AD0401
SW1	ALPS SWITCH L/TRAVEL VERT	DF0660
SW2	ALPS SWITCH L/TRAVEL VERT	DF0660
SW3	ALPS SWITCH L/TRAVEL VERT	DF0660
SW4	ALPS SWITCH L/TRAVEL VERT	DF0660
SW5	ALPS SWITCH L/TRAVEL VERT	DF0660
SW6	ALPS SWITCH L/TRAVEL VERT	DF0660
SW7	ALPS SWITCH L/TRAVEL VERT	DF0660
SW8	ALPS SWITCH L/TRAVEL VERT	DF0660
XLR	XLR A-SRS PLASTIC FML PUSH	FK0969

### FADER I/P PCB ASSY

Ident	Description	Part Number
CN1	2MM 12WY R/A ML HDR	FF0977
CN2	2MM 12WY R/A ML HDR	FF0977
CN3	2MM 12WY R/A ML HDR	FF0977
CN4	2MM 12WY R/A ML HDR	FF0977
CN5	14WY VERT SIL HDR-SHORT PIN	FF0803
CN22	2MM 6WY R/A ML HDR	FF0978
FDR1	ALPS MONO FDR 10KD(T)+DC	DD0454
FDR2	ALPS MONO FDR 10KD(T)+DC	DD0454
FDR3	ALPS MONO FDR 10KD(T)+DC	DD0454
FDR4	ALPS MONO FDR 10KD(T)+DC	DD0454
FDR5	ALPS MONO FDR 10KD(T)+DC	DD0454
FDR6	ALPS MONO FDR 10KD(T)+DC	DD0454
FDR7	ALPS MONO FDR 10KD(T)+DC	DD0454
FDR8	ALPS MONO FDR 10KD(T)+DC	DD0454
pcb ass	SERIES TWO FADER I/P SM ASSY	RC4021A-SM

### RC4021

### CPU PCB ASSY

Ident	Description	Part Number
CN2	14WY VERT SIL HDR-SHORT PIN	FF0803
CN3	14WY VERT SIL HDR-SHORT PIN	FF0803
CN4	MINIFIT JR 6WY 2ROW V HDR	FF0911
CN5	MTHD 8WY .1" ML LCKNG PLRSD HDR	FF0569
CN6	2MM 6WY L/PRF VERT LCKG ML HDR	FF0869
CN7	MTHD .1" 6WY VERT LCKG ML HDR	FF0649
IC1	6N138 OPTO-COUPLER	BD0344
XLI	20MHZ CRYSTAL (HC49V/4H)	ZE0415
pcb ass	SERIES TWO CPU PCB SM ASSY	RC4023A-SM

### RC4023

### PSU DIST PCB ASSY

Ident	Description	Part Number
pcb	SERIES TWO PSU DIST PCB	SC4041-03
C1	POLY-CAP 5MM 5% 63V 100N	CC0252
C2	VERT ELEC 33UF/16V SSP	CE0457
C3	VERT ELEC 0.2" TPD 220UF 16V E	CE0483
C4	VERT ELEC 0.2" TPD 220UF 16V E	CE0483
C5	VERT ELEC 0.2" TPD 220UF 16V E	CE0483
CN1	MINIFIT JR 6WY 2ROW V HDR	FF0911
CN2	MINIFIT JR 6WY 2ROW V HDR	FF0911
CN3	MINIFIT JR 6WY 2ROW V HDR	FF0911
CN4	MINIFIT JR 4WY 2ROW V HDR	FF0912
CN5	MINIFIT JR 4WY 2ROW V HDR	FF0912
CN10	MINIFIT JR 4WY 2ROW V HDR	FF0912
RI	W/W 2.5W RES 5% 33R	AG0626
REG1	V.REG LM7805 +5V 1A	BE0424
REG1	REDPOINT HEATSINK CLIP PF723	PN1270

### RC4041

**MST/MIDI RR PCB ASS**

Ident	Description	Part Number
---	TS24 GENERAL PCB BRACKET	PG0871
---	TS24 GENERAL PCB BRACKET	PG0871
CN1	MTHD 8WY.1" ML LCKNG PLRSD HDR	FF0569
CN2	MTHD 8WY.1" ML LCKNG PLRSD HDR	FF0569
CN3	MTHD 8WY.1" ML LCKNG PLRSD HDR	FF0569
CN4	MTHD 8WY.1" ML LCKNG PLRSD HDR	FF0569
CN5	18WY VERT SHROUDED HDR	FF0992
CN6	18WY VERT SHROUDED HDR	FF0992
CN7	14WY VERT SHROUDED HDR	FF0991
CN8	MTHD 8WY.1" ML LCKNG PLRSD HDR	FF0569
CN9	QUAD PC PHONO SKT PHS12D	FH0755
CN10	5WY DIN 180DEG PC SKT	FK0947
CN11	5WY DIN 180DEG PC SKT	FK0947
CN12	2MM 6WY L/PRF VERT LCKG ML HDR	FF0869
Jack	JCK SKT STEREO	FH0773
Jack	JACK SKT STEREO BREAK	FH0786
SW1	ALPS SWITCH L/TRAVEL VERT	DF0660
XLR	XLR A-SRS PLASTIC ML PIN1 GND	FK0970
pcb ass	SERIES TWO MST/MIDI RR SM ASSY	RD4025A-SM

**O/P FDR PCB ASSY**

Ident	Description	Part Number
CN1	2MM 12WY R/A ML HDR	FF0977
CN2	2MM 12WY R/A ML HDR	FF0977
CN3	2MM 12WY R/A ML HDR	FF0977
CN4	2MM 12WY R/A ML HDR	FF0977
CN5	MTHD 8WY.1" ML LCKNG PLRSD HDR	FF0569
CN6	REAN SLIMJACK S203-84G	FH0760
CN7	MTHD 3WY.1" ML LCKG PLRSD HDR	FF0627
FDR1	ALPS STER FDR 10KDX2(T)+DC	DD0455
FDR10	ALPS MONO FDR 10KD(T)+DC	DD0454
FDR12	ALPS MONO FDR 10KD(T)+DC	DD0454
FDR13	ALPS STER FDR 10KDX2(T)+DC	DD0455
FDR2	ALPS STER FDR 10KDX2(T)+DC	DD0455
FDR3	ALPS MONO FDR 10KD(T)+DC	DD0454
FDR4	ALPS MONO FDR 10KD(T)+DC	DD0454
FDR5	ALPS MONO FDR 10KD(T)+DC	DD0454
FDR6	ALPS MONO FDR 10KD(T)+DC	DD0454
FDR7	ALPS MONO FDR 10KD(T)+DC	DD0454
FDR8	ALPS MONO FDR 10KD(T)+DC	DD0454
FDR9	ALPS MONO FDR 10KD(T)+DC	DD0454
LED1	LED AMBER 3MM S/B SHORT MD5543	JA0127
LED2	LED AMBER 3MM S/B SHORT MD5543	JA0127
LED3	LED AMBER 3MM S/B SHORT MD5543	JA0127
LED4	LED AMBER 3MM S/B SHORT MD5543	JA0127
LED5	LED AMBER 3MM S/B SHORT MD5543	JA0127
LED6	LED AMBER 3MM S/B SHORT MD5543	JA0127
LED7	LED AMBER 3MM S/B SHORT MD5543	JA0127
LED8	LED AMBER 3MM S/B SHORT MD5543	JA0127
SW1	ALPS (SUN) 2 POLE PUSH SWT MOM	DF0520
SW2	ALPS (SUN) 2 POLE PUSH SWT MOM	DF0520
SW3	ALPS (SUN) 2 POLE PUSH SWT MOM	DF0520
SW4	ALPS (SUN) 2 POLE PUSH SWT MOM	DF0520
SW5	ALPS (SUN) 2 POLE PUSH SWT MOM	DF0520
SW6	ALPS (SUN) 2 POLE PUSH SWT MOM	DF0520
SW7	ALPS (SUN) 2 POLE PUSH SWT MOM	DF0520
SW8	ALPS (SUN) 2 POLE PUSH SWT MOM	DF0520
pcb ass	SERIES TWO O/P FDR PCB SM ASSY	RD4026A-SM

**AUDIO I/P PCB ASSY**

Ident	Description	Part Number
CA1	VERT ELEC 0.2"TPD 2.2UF/50 SSP	CE0416
CA2	VERT ELEC 0.2"TPD 2.2UF/50 SSP	CE0416
CA3	VERT ELEC 330MF/6.3V 6.3D 11L	CE0455
CA4	VERT ELEC 330MF/6.3V 6.3D 11L	CE0455
CA7	VERT ELEC 33UF/16V SSP	CE0457
CA8	VERT ELEC 0.2"TPD 2.2UF/50 SSP	CE0416
CA9	MICRO-BOX 5MM 5% 63V 33N	CC0247

**RD4025****RD4026****RE4019**



CA10	MICRO-BOX 5MM 5% 63V 33N	CC0247
CA11	VERT ELEC 33UF/16V SSP	CE0457
CA12	MICRO-BOX 5MM 5% 63V 6N8	CC0243
CA13	MICRO-BOX 5MM 5% 63V 6N8	CC0243
CA14	MICRO-BOX 5MM 5% 63V 6N8	CC0243
CA15	MICRO-BOX 5MM 5% 63V 1N	CC0238
CA16	MICRO-BOX 5MM 5% 63V 2N2	CC0240
CA17	MICRO-BOX 5MM 5% 63V 6N8	CC0243
CA18	MICRO-BOX 5MM 5% 63V 15N	CC0245
CA19	MICRO-BOX 5MM 5% 63V 47N	CC0248
CA20	MICRO-BOX 5MM 5% 63V 47N	CC0248
CA21	VERT ELEC 0.2"TPD 2.2UF/50 SSP	CE0416
CA23	VERT ELEC 33UF/16V SSP	CE0457
CA24	VERT ELEC 1UF 63V 4D 7L SSP	CE0485
CA25	VERT ELEC 1UF 63V 4D 7L SSP	CE0485
CA26	VERT ELEC 33UF/16V SSP	CE0457
CA32	VERT ELEC 0.2"TPD 47UF 25V SKP	CE0401
CA33	VERT ELEC 0.2"TPD 47UF 25V SKP	CE0401
CG34	VERT ELEC 0.2"TPD 47UF 25V SKP	CE0401
CN1	24WY VERT SHROUDED HDR	FF0993
CN2	14WY VERT SIL HDR-SHORT PIN	FF0803
CN3	14WY VERT SIL HDR-SHORT PIN	FF0803
CN4	2MM 12WY L/PRF VERT ML HDR	FF0860
CN5	8WY VERT SHROUDED HDR	FF0990
CN6	8WY VERT SHROUDED HDR	FF0990
CN7	2MM 6WY L/PRF VERT LCKG ML HDR	FF0869
CN8	AMP 4WY VERT ML LTCHG HDR	FF0987
CN9	2MM 12WY L/PRF VERT ML HDR	FF0860
CN10	8WY VERT SHROUDED HDR	FF0990
CN11	2MM 12WY L/PRF VERT ML HDR	FF0860
CN13	2MM 12WY L/PRF VERT ML HDR	FF0860
CN14	24WY VERT SHROUDED HDR	FF0993
LDA1	LED RED 3MM S/B" 17.5"-MD6748	JA0109
LDA2	LED AMBER 3MM S/B 17.5 MD6748	JA0129
QA1	PNP TRANS 2SB737 LOW RBB	BD0346
QA2	PNP TRANS 2SB737 LOW RBB	BD0346
QA7	FET SWITCH J111 (TAPED)	BD0320
QA8	FET SWITCH J111 (TAPED)	BD0320
QA9	FET SWITCH J111 (TAPED)	BD0320
RI	MF0.25W RES 2% 4R7	AD0398
R2	MF0.25W RES 2% 4R7	AD0398
SA1-15	ALPS SWITCH L/TRAVEL VERT	DF0660
SA16	ALPS SWT L/TRAVEL VERT MOM	DF0662
SA17-18	ALPS SWITCH L/TRAVEL VERT	DF0660
VA1	ALPS 9MM VERT 10KRD ESD PROOF	DM1365-ESD
VA2	ALPS 100KE VERT CD DUAL	DM1364
VA3	ALPS 9MM VRT SHRT-D 20KB CDCOL	DM1250
VA4	ALPS 11MM VERT 200KCX2 HIGH/D	DM1323
VA5	ALPS 9MM VRT SHRT-D 20KB CDCOL	DM1250
VA6	ALPS 11MM VERT 200KCX2 HIGH/D	DM1323
VA7	ALPS 9MM VRT SHRT-D 20KB CDCOL	DM1250
VA8	ALPS 9MM VRT SHRT-D 20KB CDCOL	DM1250
VA17	ALPS 12MM 10KA&10KC CD DUAL	DM1352
VA9-16	ALPS 9MM VRT SHRT-D 20KK COL	DM1251
pcb ass	SERIES TWO AUDIO I/P SM ASSY	RE4019A-SM

## MASTER PCB ASSY

Ident	Description
C7	VERT ELEC 33UF/16V SSP
C10	VERT ELEC 330MF/6.3V 6.3D 11L
C11	VERT ELEC 330MF/6.3V 6.3D 11L
C16	VERT ELEC 33UF/16V SSP
C17	VERT ELEC 0.2"TPD 2.2UF/50 SSP
C17	VERT ELEC 33UF/16V SSP
C18	VERT ELEC 0.2"TPD 2.2UF/50 SSP
C18	VERT ELEC 0.2"TPD 2.2UF/50 SSP
C19	VERT ELEC 0.2"TPD 2.2UF/50 SSP
C22	VERT ELEC 330MF/6.3V 6.3D 11L
C23	VERT ELEC 330MF/6.3V 6.3D 11L
C28	VERT ELEC 0.2"TPD 2.2UF/50 SSP
C33	VERT ELEC 0.2"TPD 2.2UF/50 SSP
C34	VERT ELEC 0.2"TPD 47UF 25V SKP
C37	VERT ELEC 0.2"TPD 2.2UF/50 SSP
C37	VERT ELEC 220UF 25V SKP
C38	VERT ELEC 0.2"TPD 2.2UF/50 SSP

## RF4020

Part Number
CE0457
CE0455
CE0455
CE0457
CE0416
CE0457
CE0416
CE0416
CE0416
CE0455
CE0455
CE0416
CE0416
CE0416
CE0401
CE0416
CE0422
CE0416

C38	VERT ELEC 330MF/6.3V 6.3D 1 IL	CE0455
C41	VERT ELEC 33UF/16V SSP	CE0457
C42	VERT ELEC 33UF/16V SSP	CE0457
C44	VERT ELEC 330MF/6.3V 6.3D 1 IL	CE0455
C47	VERT ELEC 33UF/16V SSP	CE0457
C48	VERT ELEC 0.2"TPD 2.2UF/50 SSP	CE0416
C49	VERT ELEC 330MF/6.3V 6.3D 1 IL	CE0455
C52	VERT ELEC 33UF/16V SSP	CE0457
C53	VERT ELEC 0.2"TPD 2.2UF/50 SSP	CE0416
C54	VERT ELEC 33UF/16V SSP	CE0457
C55	VERT ELEC 33UF/16V SSP	CE0457
C56	VERT ELEC 33UF/16V SSP	CE0457
C57	VERT ELEC 0.2"TPD 2.2UF/50 SSP	CE0416
C57	VERT ELEC 33UF/16V SSP	CE0457
C58	VERT ELEC 0.2"TPD 2.2UF/50 SSP	CE0416
C60	VERT ELEC 33UF/16V SSP	CE0457
C61	VERT ELEC 33UF/16V SSP	CE0457
C64	VERT ELEC 33UF/16V SSP	CE0457
C65	VERT ELEC 33UF/16V SSP	CE0457
C68	VERT ELEC 0.2"TPD 2.2UF/50 SSP	CE0416
C73	VERT ELEC 0.2"TPD 2.2UF/50 SSP	CE0416
C77	VERT ELEC 0.2"TPD 2.2UF/50 SSP	CE0416
C78	VERT ELEC 0.2"TPD 2.2UF/50 SSP	CE0416
C82	VERT ELEC 0.2"TPD 2.2UF/50 SSP	CE0416
C83	VERT ELEC 0.2"TPD 2.2UF/50 SSP	CE0416
C89	VERT ELEC 0.2"TPD 47UF 25V SKP	CE0401
C90	VERT ELEC 0.2"TPD 47UF 25V SKP	CE0401
C91	VERT ELEC SSP 10UF/16V	CE0448
C92	VERT ELEC 100UF 25V SKP	CE0446
C95	VERT ELEC 100UF 25V SKP	CE0446
C97	VERT ELEC 100UF 25V SKP	CE0446
C98	VERT ELEC 100UF 25V SKP	CE0446
C99	VERT ELEC 100UF 25V SKP	CE0446
C100	VERT ELEC 100UF 25V SKP	CE0446
CA2	VERT ELEC 33UF/16V SSP	CE0457
CA4	VERT ELEC 330MF/6.3V 6.3D 1 IL	CE0455
CA6	VERT ELEC 33UF/16V SSP	CE0457
CA8	VERT ELEC 330MF/6.3V 6.3D 1 IL	CE0455
CA10	VERT ELEC 330MF/6.3V 6.3D 1 IL	CE0455
CA13	VERT ELEC 33UF/16V SSP	CE0457
CA14	VERT ELEC 330MF/6.3V 6.3D 1 IL	CE0455
CA15	VERT ELEC 330MF/6.3V 6.3D 1 IL	CE0455
CA18	VERT ELEC 33UF/16V SSP	CE0457
CA19	VERT ELEC 330MF/6.3V 6.3D 1 IL	CE0455
CN1	2MM 12WY L/PRF VERT ML HDR	FF0860
CN2	2MM 12WY L/PRF VERT ML HDR	FF0860
CN3	2MM 12WY L/PRF VERT ML HDR	FF0860
CN4	18WY VERT SIL HDR-SHORT PIN	FF0806
CN5	8WY VERT SHROUDED HDR	FF0990
CN6	14WY VERT SIL HDR-SHORT PIN	FF0803
CN7	MTHD 3WY .1" ML LCKG PLRSD HDR	FF0627
CN8	AMP 4WY VERT ML LTCHG HDR	FF0987
CN9	2MM 12WY L/PRF VERT ML HDR	FF0860
CN10	18WY VERT SIL HDR-SHORT PIN	FF0806
CN11	14WY VERT SIL HDR-SHORT PIN	FF0803
CN12	MTHD .1" 4WY VERT LCKG ML HDR	FF0638
CN13	MTHD 8WY .1" ML LCKNG PLRSD HDR	FF0569
CN14	14WY VERT SIL HDR-SHORT PIN	FF0803
CN15	MIINIFIT JR 6WY 2ROW V HDR	FF0911
CN16	8WY VERT SHROUDED HDR	FF0990
CN17	MTHD 8WY .1" ML LCKNG PLRSD HDR	FF0569
CN18	MTHD 8WY .1" ML LCKNG PLRSD HDR	FF0569
CN19	MTHD .1" 4WY VERT LCKG ML HDR	FF0638
CN20	MTHD 8WY .1" ML LCKNG PLRSD HDR	FF0569
CN21	MTHD 3WY .1" ML LCKG PLRSD HDR	FF0627
CN22	MIINIFIT JR 4WY 2ROW V HDR	FF0912
CR3	VERT ELEC 0.2"TPD 100UF 10V SK	CE0403
CR4	MICRO-BOX 5MM 5% 63V 22N	CC0246
CR4	VERT ELEC 0.2"TPD 100UF 10V SK	CE0403
CR5	MICRO-BOX 5MM 5% 63V 22N	CC0246
CR5	VERT ELEC 33UF/16V SSP	CE0457
CR6	VERT ELEC 33UF/16V SSP	CE0457
CR8	VERT ELEC 0.2"TPD 2.2UF/50 SSP	CE0416
CR9	VERT ELEC 330MF/6.3V 6.3D 1 IL	CE0455
CR13	VERT ELEC 0.2"TPD 100UF 10V SK	CE0403
CR14	MICRO-BOX 5MM 5% 63V 22N	CC0246

CR15	MICRO-BOX 5MM 5% 63V 22N	CC0246
CR16	VERT ELEC 0.2"TPD 100UF 10V SK	CE0403
CR16	VERT ELEC 33UF/16V SSP	CE0457
CR18	VERT ELEC 0.2"TPD 100UF 10V SK	CE0403
CR19	VERT ELEC 330MF/6.3V 6.3D 1 IL	CE0455
CR23	VERT ELEC 0.2"TPD 100UF 10V SK	CE0403
CR24	MICRO-BOX 5MM 5% 63V 22N	CC0246
CR24	VERT ELEC 0.2"TPD 100UF 10V SK	CE0403
CR25	MICRO-BOX 5MM 5% 63V 22N	CC0246
CR26	VERT ELEC 33UF/16V SSP	CE0457
CR29	VERT ELEC 330MF/6.3V 6.3D 1 IL	CE0455
CR33	VERT ELEC 0.2"TPD 100UF 10V SK	CE0403
CR34	MICRO-BOX 5MM 5% 63V 22N	CC0246
CR35	MICRO-BOX 5MM 5% 63V 22N	CC0246
CR36	VERT ELEC 0.2"TPD 100UF 10V SK	CE0403
CR36	VERT ELEC 33UF/16V SSP	CE0457
CR38	VERT ELEC 0.2"TPD 100UF 10V SK	CE0403
CR39	VERT ELEC 330MF/6.3V 6.3D 1 IL	CE0455
CR43	VERT ELEC 0.2"TPD 100UF 10V SK	CE0403
CR43	VERT ELEC 0.2"TPD 100UF 10V SK	CE0403
CR44	MICRO-BOX 5MM 5% 63V 22N	CC0246
CR44	VERT ELEC 0.2"TPD 100UF 10V SK	CE0403
CR45	MICRO-BOX 5MM 5% 63V 22N	CC0246
CR46	VERT ELEC 33UF/16V SSP	CE0457
CR49	VERT ELEC 330MF/6.3V 6.3D 1 IL	CE0455
CR53	VERT ELEC 0.2"TPD 100UF 10V SK	CE0403
CR54	MICRO-BOX 5MM 5% 63V 22N	CC0246
CR55	MICRO-BOX 5MM 5% 63V 22N	CC0246
CR56	VERT ELEC 0.2"TPD 100UF 10V SK	CE0403
CR58	VERT ELEC 0.2"TPD 100UF 10V SK	CE0403
CR59	VERT ELEC 330MF/6.3V 6.3D 1 IL	CE0455
CR63	VERT ELEC 0.2"TPD 100UF 10V SK	CE0403
CR64	MICRO-BOX 5MM 5% 63V 22N	CC0246
CR64	VERT ELEC 0.2"TPD 100UF 10V SK	CE0403
CR65	MICRO-BOX 5MM 5% 63V 22N	CC0246
CR66	VERT ELEC 33UF/16V SSP	CE0457
CR69	VERT ELEC 330MF/6.3V 6.3D 1 IL	CE0455
CR73	VERT ELEC 0.2"TPD 100UF 10V SK	CE0403
CR74	MICRO-BOX 5MM 5% 63V 22N	CC0246
CR75	MICRO-BOX 5MM 5% 63V 22N	CC0246
CR76	VERT ELEC 0.2"TPD 100UF 10V SK	CE0403
CR76	VERT ELEC 33UF/16V SSP	CE0457
CR78	VERT ELEC 0.2"TPD 100UF 10V SK	CE0403
CR79	VERT ELEC 330MF/6.3V 6.3D 1 IL	CE0455
CS5	MICRO-BOX 5MM 5% 63V 6N8	CC0243
CS6	MICRO-BOX 5MM 5% 63V 6N8	CC0243
CS7	MICRO-BOX 5MM 5% 63V 6N8	CC0243
CS9	MICRO-BOX 5MM 5% 63V 1N	CC0238
CS10	MICRO-BOX 5MM 5% 63V 2N2	CC0240
CS11	MICRO-BOX 5MM 5% 63V 6N8	CC0243
CS12	MICRO-BOX 5MM 5% 63V 15N	CC0245
CS13	VERT ELEC 0.2"TPD 2.2UF/50 SSP	CE0416
CS14	MICRO-BOX 5MM 5% 63V 47N	CC0248
CS15	MICRO-BOX 5MM 5% 63V 47N	CC0248
CS25	MICRO-BOX 5MM 5% 63V 6N8	CC0243
CS26	MICRO-BOX 5MM 5% 63V 6N8	CC0243
CS27	MICRO-BOX 5MM 5% 63V 6N8	CC0243
CS29	MICRO-BOX 5MM 5% 63V 1N	CC0238
CS30	MICRO-BOX 5MM 5% 63V 2N2	CC0240
CS31	MICRO-BOX 5MM 5% 63V 6N8	CC0243
CS32	MICRO-BOX 5MM 5% 63V 15N	CC0245
CS34	MICRO-BOX 5MM 5% 63V 47N	CC0248
CS35	MICRO-BOX 5MM 5% 63V 47N	CC0248
CS45	MICRO-BOX 5MM 5% 63V 6N8	CC0243
CS46	MICRO-BOX 5MM 5% 63V 6N8	CC0243
CS47	MICRO-BOX 5MM 5% 63V 6N8	CC0243
CS49	MICRO-BOX 5MM 5% 63V 1N	CC0238
CS50	MICRO-BOX 5MM 5% 63V 2N2	CC0240
CS51	MICRO-BOX 5MM 5% 63V 6N8	CC0243
CS52	MICRO-BOX 5MM 5% 63V 15N	CC0245
CS54	MICRO-BOX 5MM 5% 63V 47N	CC0248
CS55	MICRO-BOX 5MM 5% 63V 47N	CC0248
CS65	MICRO-BOX 5MM 5% 63V 6N8	CC0243
CS66	MICRO-BOX 5MM 5% 63V 6N8	CC0243
CS67	MICRO-BOX 5MM 5% 63V 6N8	CC0243
CS69	MICRO-BOX 5MM 5% 63V 1N	CC0238

CS70	MICRO-BOX 5MM 5% 63V 2N2	CC0240
CS71	MICRO-BOX 5MM 5% 63V 6N8	CC0243
CS72	MICRO-BOX 5MM 5% 63V 15N	CC0245
CS74	MICRO-BOX 5MM 5% 63V 47N	CC0248
CS75	MICRO-BOX 5MM 5% 63V 47N	CC0248
FD1	PAN 75MM STEREO FADER 10KA	DD0409
FD2	PAN 75MM STEREO FADER 10KA	DD0409
FD3	PAN 75MM STEREO FADER 10KA	DD0409
FD4	PAN 75MM STEREO FADER 10KA	DD0409
LDA1	LED AMBER 3MM S/B 17.5 MD6748	JA0129
LDA2	LED AMBER 3MM S/B 17.5 MD6748	JA0129
LDA3	LED AMBER 3MM S/B 17.5 MD6748	JA0129
LDA4	LED AMBER 3MM S/B 17.5 MD6748	JA0129
LDR1	LED AMBER 3MM S/B 17.5 MD6748	JA0129
LDR2	LED RED 3MM S/B"17.5"-MD6748	JA0109
LDR3	LED AMBER 3MM S/B 17.5 MD6748	JA0129
LDR4	LED RED 3MM S/B"17.5"-MD6748	JA0109
LDR5	LED AMBER 3MM S/B 17.5 MD6748	JA0129
LDR6	LED RED 3MM S/B"17.5"-MD6748	JA0109
LDR7	LED AMBER 3MM S/B 17.5 MD6748	JA0129
LDR8	LED RED 3MM S/B"17.5"-MD6748	JA0109
LDS1	LED RED 3MM S/B"17.5"-MD6748	JA0109
LDS2	LED AMBER 3MM S/B 17.5 MD6748	JA0129
LDS3	LED RED 3MM S/B"17.5"-MD6748	JA0109
LDS4	LED AMBER 3MM S/B 17.5 MD6748	JA0129
LED1	LED AMBER 3MM S/B UNPRE	JA0126
LED2	LED GREEN 3MM S/B UNPRE	JA0101
LED3	LED RED 3MM S/B UNPRE	JA0100
LED4	LED AMBER 3MM S/B 17.5 MD6748	JA0129
LED5	LED AMBER 3MM S/B 17.5 MD6748	JA0129
LED6	8WY SIL SKT (MADE FROM FF0538)	FF0620
LED6	3 DIGIT BRIGHT RED LED DISPLAY	JE0416
LED7	LED GREEN 3MM S/B UNPRE	JA0101
LED8	LED GREEN 3MM S/B UNPRE	JA0101
LED9	LED AMBER 3MM S/B UNPRE	JA0126
QR1	FET SWITCH J111 (TAPED)	BD0320
QR2	FET SWITCH J111 (TAPED)	BD0320
QR3	FET SWITCH J111 (TAPED)	BD0320
QR4	FET SWITCH J111 (TAPED)	BD0320
QR11	FET SWITCH J111 (TAPED)	BD0320
QR12	FET SWITCH J111 (TAPED)	BD0320
QR13	FET SWITCH J111 (TAPED)	BD0320
QR14	FET SWITCH J111 (TAPED)	BD0320
QR21	FET SWITCH J111 (TAPED)	BD0320
QR22	FET SWITCH J111 (TAPED)	BD0320
QR23	FET SWITCH J111 (TAPED)	BD0320
QR24	FET SWITCH J111 (TAPED)	BD0320
QR31	FET SWITCH J111 (TAPED)	BD0320
QR32	FET SWITCH J111 (TAPED)	BD0320
QR33	FET SWITCH J111 (TAPED)	BD0320
QR34	FET SWITCH J111 (TAPED)	BD0320
QS1	FET SWITCH J111 (TAPED)	BD0320
QS2	FET SWITCH J111 (TAPED)	BD0320
QS3	FET SWITCH J111 (TAPED)	BD0320
QS4	FET SWITCH J111 (TAPED)	BD0320
QS11	FET SWITCH J111 (TAPED)	BD0320
QS12	FET SWITCH J111 (TAPED)	BD0320
QS13	FET SWITCH J111 (TAPED)	BD0320
QS14	FET SWITCH J111 (TAPED)	BD0320
RI50	MF0.25W RES 2% 4R7	AD0398
RI51	MF0.25W RES 2% 4R7	AD0398
RI52	MF0.25W RES 2% 4R7	AD0398
RI53	MF0.25W RES 2% 4R7	AD0398
RI54	MF0.25W RES 2% 4R7	AD0398
RI55	MF0.25W RES 2% 4R7	AD0398
S19	SALPS SWT L/TRAVEL VERT MOM	DF0662
SA1	ALPS SWITCH L/TRAVEL VERT	DF0660
SA2	ALPS SWITCH L/TRAVEL VERT	DF0660
SA3	ALPS SWITCH L/TRAVEL VERT	DF0660
SA4	ALPS SWITCH L/TRAVEL VERT	DF0660
SA5	ALPS SWITCH L/TRAVEL VERT	DF0660
SA6	ALPS SWITCH L/TRAVEL VERT	DF0660
SA7	ALPS SWITCH L/TRAVEL VERT	DF0660
SA8	ALPS SWITCH L/TRAVEL VERT	DF0660
SR1	ALPS SWITCH L/TRAVEL VERT	DF0660
SR2	ALPS SWITCH L/TRAVEL VERT	DF0660

---

SR3	ALPS SWITCH L/TRAVEL VERT	DF0660
SR4	ALPS SWITCH L/TRAVEL VERT	DF0660
SR5	ALPS SWITCH L/TRAVEL VERT	DF0660
SR6	ALPS SWITCH L/TRAVEL VERT	DF0660
SR7	ALPS SWITCH L/TRAVEL VERT	DF0660
SR8	ALPS SWITCH L/TRAVEL VERT	DF0660
SR9	SALPS SWT L/TRAVEL VERT MOM	DF0662
SR11	ALPS SWITCH L/TRAVEL VERT	DF0660
SR12	ALPS SWITCH L/TRAVEL VERT	DF0660
SR13	ALPS SWITCH L/TRAVEL VERT	DF0660
SR14	ALPS SWITCH L/TRAVEL VERT	DF0660
SR15	ALPS SWITCH L/TRAVEL VERT	DF0660
SR16	ALPS SWITCH L/TRAVEL VERT	DF0660
SR17	ALPS SWITCH L/TRAVEL VERT	DF0660
SR18	ALPS SWITCH L/TRAVEL VERT	DF0660
SR21	ALPS SWITCH L/TRAVEL VERT	DF0660
SR22	ALPS SWITCH L/TRAVEL VERT	DF0660
SR23	ALPS SWITCH L/TRAVEL VERT	DF0660
SR24	ALPS SWITCH L/TRAVEL VERT	DF0660
SR25	ALPS SWITCH L/TRAVEL VERT	DF0660
SR26	ALPS SWITCH L/TRAVEL VERT	DF0660
SR27	ALPS SWITCH L/TRAVEL VERT	DF0660
SR28	ALPS SWITCH L/TRAVEL VERT	DF0660
SR29	SALPS SWT L/TRAVEL VERT MOM	DF0662
SR31	ALPS SWITCH L/TRAVEL VERT	DF0660
SR32	ALPS SWITCH L/TRAVEL VERT	DF0660
SR33	ALPS SWITCH L/TRAVEL VERT	DF0660
SR34	ALPS SWITCH L/TRAVEL VERT	DF0660
SR35	ALPS SWITCH L/TRAVEL VERT	DF0660
SR36	ALPS SWITCH L/TRAVEL VERT	DF0660
SR37	ALPS SWITCH L/TRAVEL VERT	DF0660
SR38	ALPS SWITCH L/TRAVEL VERT	DF0660
SR39	SALPS SWT L/TRAVEL VERT MOM	DF0662
SS1	ALPS SWITCH L/TRAVEL VERT	DF0660
SS2	ALPS SWITCH L/TRAVEL VERT	DF0660
SS3	ALPS SWITCH L/TRAVEL VERT	DF0660
SS4	ALPS SWITCH L/TRAVEL VERT	DF0660
SS5	ALPS SWITCH L/TRAVEL VERT	DF0660
SS6	ALPS SWITCH L/TRAVEL VERT	DF0660
SS7	ALPS SWITCH L/TRAVEL VERT	DF0660
SS8	ALPS SWITCH L/TRAVEL VERT	DF0660
SS9	ALPS SWITCH L/TRAVEL VERT	DF0660
SS10	ALPS SWITCH L/TRAVEL VERT	DF0660
SS11	ALPS SWITCH L/TRAVEL VERT	DF0660
SS12	ALPS SWITCH L/TRAVEL VERT	DF0660
SS13	ALPS SWITCH L/TRAVEL VERT	DF0660
SS14	ALPS SWITCH L/TRAVEL VERT	DF0660
SS15	ALPS SWITCH L/TRAVEL VERT	DF0660
SS16	ALPS SWITCH L/TRAVEL VERT	DF0660
SS17	ALPS SWITCH L/TRAVEL VERT	DF0660
SS18	ALPS SWITCH L/TRAVEL VERT	DF0660
SS19	ALPS SWITCH L/TRAVEL VERT	DF0660
SS20	ALPS SWITCH L/TRAVEL VERT	DF0660
SS22	ALPS SWITCH L/TRAVEL VERT	DF0660
SS23	ALPS SWT L/TRAVEL VERT MOM	DF0662
SS24	ALPS SWITCH L/TRAVEL VERT	DF0660
SW1	ALPS SWITCH L/TRAVEL VERT	DF0660
SW2	ALPS SWITCH L/TRAVEL VERT	DF0660
SW3	ALPS SWITCH L/TRAVEL VERT	DF0660
SW4	ALPS SWITCH L/TRAVEL VERT	DF0660
SW5	ALPS SWITCH L/TRAVEL VERT	DF0660
SW6	ALPS SWITCH L/TRAVEL VERT	DF0660
SW7	ALPS SWITCH L/TRAVEL VERT	DF0660
SW8	ALPS SWITCH L/TRAVEL VERT	DF0660
SW9	ALPS SWITCH L/TRAVEL VERT	DF0660
SW10	ALPS SWITCH L/TRAVEL VERT	DF0660
SW11	ALPS SWITCH L/TRAVEL VERT	DF0660
SW12	ALPS SWITCH L/TRAVEL VERT	DF0660
SW13	ALPS SWITCH L/TRAVEL VERT	DF0660
SW14	ALPS SWITCH L/TRAVEL VERT	DF0660
SW15	ALPS SWT L/TRAVEL VERT MOM	DF0662
SW17	ALPS SWT L/TRAVEL VERT MOM	DF0662
SW18	ALPS SWT L/TRAVEL VERT MOM	DF0662
SW19	ALPS SWT L/TRAVEL VERT MOM	DF0662
SW20	ALPS SWT L/TRAVEL VERT MOM	DF0662
SW21	ALPS SWT L/TRAVEL VERT MOM	DF0662

---

SW22	ALPS SWT L/TRAVEL VERT MOM	DF0662
SW23	ALPS SWITCH L/TRAVEL VERT	DF0660
SW24	ALPS SWT L/TRAVEL VERT MOM	DF0662
SW31	ALPS SWT L/TRAVEL VERT MOM	DF0662
TR4	J112 MOTOROLA TPD(RF4020 ONLY)	BD0418
TR5	PNP TRANS 2SB737 LOW RBB	BD0346
TR6	PNP TRANS 2SB737 LOW RBB	BD0346
VS1	PAN 12MM 5KC DUAL L/SHT	DM1306
VS2	PAN 12MM 20KB C/D DUAL	DM1239
VS3	PAN 12MM 20KB C/D DUAL	DM1239
VS4	PAN 12MM 20KB C/D DUAL	DM1239
VS5	PAN 12MM 20KB C/D DUAL	DM1239
VA1	ALPS 9MM VRT SHRT-D 20KK COL	DM1251
VA2	ALPS 9MM VRT SHRT-D 20KK COL	DM1251
VA3	ALPS 12MM 10KA&10KC CD DUAL	DM1352
VA4	ALPS 12MM 10KA&10KC CD DUAL	DM1352
VR1	PAN 12MM 20KU DUAL BUSHED	DM1246
VR2	PAN 12MM 10KU DUAL	DM1240
VR3	PAN 12MM 10KU DUAL	DM1240
VR26	PAN 12MM 10KU DUAL	DM1240
VR27	PAN 12MM 10KU DUAL	DM1240
VR28	ALPS 9MM VERT(SHRT-D)5KRD	DM1219
VR29	PAN 12MM 5KC DUAL L/SHT	DM1306
VR30	PAN 12MM 20KB C/D DUAL	DM1239
VR35	PAN 12MM 5KC DUAL L/SHT	DM1306
VR36	PAN 12MM 20KB C/D DUAL	DM1239
VR41	PAN 12MM 5KC DUAL L/SHT	DM1306
VR42	PAN 12MM 20KB C/D DUAL	DM1239
VR47	PAN 12MM 5KC DUAL L/SHT	DM1306
VR48	PAN 12MM 20KB C/D DUAL	DM1239
VR31-34	ALPS 9MM VRT SHRT-D 20KK COL	DM1251
VR37-40	ALPS 9MM VRT SHRT-D 20KK COL	DM1251
VR4-25	ALPS 9MM VRT SHRT-D 20KK COL	DM1251
VR43-46	ALPS 9MM VRT SHRT-D 20KK COL	DM1251
VR49-52	ALPS 9MM VRT SHRT-D 20KK COL	DM1251
VS14	ALPS 12MM 10KA&10KC CD DUAL	DM1352
VS21	PAN 12MM 5KC DUAL L/SHT	DM1306
VS22	PAN 12MM 20KB C/D DUAL	DM1239
VS23	PAN 12MM 20KB C/D DUAL	DM1239
VS24	PAN 12MM 20KB C/D DUAL	DM1239
VS25	PAN 12MM 20KB C/D DUAL	DM1239
VS26-28	ALPS 9MM VRT SHRT-D 20KK COL	DM1251
VS34	ALPS 12MM 10KA&10KC CD DUAL	DM1352
VS6-13	ALPS 9MM VRT SHRT-D 20KK COL	DM1251
pcb ass	SERIES TWO MASTER PCB SM ASSY	RF4020A-SM

## I/P MTR PCB ASSY

Ident	Description	Part Number
C13	VERT ELEC 220UF 25V SKP	CE0422
C14	VERT ELEC 220UF 25V SKP	CE0422
C15	VERT ELEC 220UF 25V SKP	CE0422
C16	VERT ELEC 220UF 25V SKP	CE0422
CN1	FFC 8WY R/A 1.25 FML HDR	FF0984
CN2	8WY VERT SHROUDED HDR	FF0990
CN3	8WY VERT SHROUDED HDR	FF0990
CN4	8WY VERT SHROUDED HDR	FF0990
CN5	FFC 8WY R/A 1.25 FML HDR	FF0984
CN6	FFC 8WY R/A 1.25 FML HDR	FF0984
CN7	FFC 8WY R/A 1.25 FML HDR	FF0984
CN8	FFC 8WY R/A 1.25 FML HDR	FF0984
CN9	FFC 8WY R/A 1.25 FML HDR	FF0984
FR1	(Safety Critical Part)! MF 0.33W RES 5% 1R FUSIBLE	AD8001
FR2	(Safety Critical Part)! MF 0.33W RES 5% 1R FUSIBLE	AD8001
LED1	12WY LED ARRAY DISPLAY	JD0395
LED2	12WY LED ARRAY DISPLAY	JD0395
LED3	12WY LED ARRAY DISPLAY	JD0395
LED4	12WY LED ARRAY DISPLAY	JD0395
LED5	12WY LED ARRAY DISPLAY	JD0395
LED6	12WY LED ARRAY DISPLAY	JD0395
LED7	12WY LED ARRAY DISPLAY	JD0395
LED8	12WY LED ARRAY DISPLAY	JD0395
pcb ass	SERIES TWO I/P MTR PCB SM ASSY	RF4022A-SM

## RF4022

---

**O/P MTR PCB ASSY****RF4027**

<b>Ident</b>	<b>Description</b>	<b>Part Number</b>
C14	VERT ELEC 220UF 25V SKP	CE0422
C22	VERT ELEC 220UF 25V SKP	CE0422
C23	VERT ELEC 220UF 25V SKP	CE0422
C24	VERT ELEC 220UF 25V SKP	CE0422
CN1	MINIFIT JR 4WY 2ROW V HDR	FF0912
CN2	8WY VERT SHROUDED HDR	FF0990
CN3	MTHD .1" 4WY VERT LCKG ML HDR	FF0638
CN4	MTHD 8WY .1" ML LCKNG PLRSD HDR	FF0569
CN5	MTHD .1" 4WY VERT LCKG ML HDR	FF0638
CN6	FFC 8WY R/A 1.25 FML HDR	FF0984
CN7	FFC 8WY R/A 1.25 FML HDR	FF0984
CN8	FFC 8WY R/A 1.25 FML HDR	FF0984
CN9	FFC 8WY R/A 1.25 FML HDR	FF0984
CN10	FFC 8WY R/A 1.25 FML HDR	FF0984
CN11	FFC 8WY R/A 1.25 FML HDR	FF0984
FR1	(Safety Critical Part)! MF 0.33W RES 5% 1R FUSIBLE	AD8001
FR2	(Safety Critical Part)! MF 0.33W RES 5% 1R FUSIBLE	AD8001
LED1	12WY LED ARRAY DISPLAY	JD0395
LED2	12WY LED ARRAY DISPLAY	JD0395
LED3	12WY LED ARRAY DISPLAY	JD0395
LED4	12WY LED ARRAY DISPLAY	JD0395
LED5	12WY LED ARRAY DISPLAY	JD0395
LED6	12WY LED ARRAY DISPLAY	JD0395
LED7	12WY LED ARRAY DISPLAY	JD0395
LED8	12WY LED ARRAY DISPLAY	JD0395
LED9	12WY LED ARRAY DISPLAY	JD0395
LED10	12WY LED ARRAY DISPLAY	JD0395
LED11	12WY LED ARRAY DISPLAY	JD0395
LED12	12WY LED ARRAY DISPLAY	JD0395
LED13	12WY LED ARRAY DISPLAY	JD0395
LED14	12WY LED ARRAY DISPLAY	JD0395
LED15	12WY LED ARRAY DISPLAY	JD0395
pcb ass	SERIES TWO O/P MTR PCB SM ASSY	RF4027A-SM

---

## SWITCH TOPS, FADER TOPS AND KNOBS

Description	Part Number	Used in: (part number)
11MM SERIES TWO KNOB GRY/BLK	KA0375	RW5594
11MM SERIES TWO KNOB GRY/BLUE	KA0377	RW5594
11MM SERIES TWO KNOB GRY/GRY	KA0374	RW5594
11MM SERIES TWO KNOB GRY/RED	KA0373	RW5594
11MM SERIES TWO KNOB GRY/YEL	KA0378	RW5594
11MM SERIES TWO LNOB GRY/GRN	KA0376	RW5594
S/THROW 2-PRT FDR KNOB-BLU/193	KA0226	RW5594
SERIES TWO SWITCH CAP GREY	KB2260	RW5594
SHINY 2-PRT FDR KNOB-BLACK	KA0348	RW5594
SHINY 2-PRT FDR KNOB-LT BLUE	KA0343	RW5594
SHINY 2-PRT FDR KNOB-RED	KA0345	RW5594
SHINY 2-PRT FDR KNOB-WHITE	KA0346	RW5594
SHINY 2-PRT FDR KNOB-YELLOW	KA0347	RW5594
SPIRIT FOLIO EXT PUSH BTN	KB1656	RW5594



---

## FADERS

Description	Part Number	Used in: (part number)
ALPS MONO FDR 10KD(T)+DC	DD0454	RC4021, RD4026
ALPS STER FDR 10KDX2(T)+DC	DD0455	RD4026
PAN 75MM STEREO FADER 10KA	DD0409	RF4020







R37	SM0805 RES 470R 1% 0.1W T200	AS0471R-0805F
R38	SM0805 RES 470R 1% 0.1W T200	AS0471R-0805F
R39	SM0805 RES 470R 1% 0.1W T200	AS0471R-0805F
R40	SM0805 RES 470R 1% 0.1W T200	AS0471R-0805F
R41	SM0805 RES 10R 1% 0.1W T200	AS0100R-0805F

## AUDIO I/P SM ASSY

Ident	Description
pcb	SERIES TWO AUDIO I/P PCB
CA22	CAP CRMC 100PF 10% 100V
CA27	CAP CRMC 100PF 10% 100V
CA5	CAP CRMC 22PF 5% 50V NP0
CA6	CAP CRMC 22PF 5% 50V NP0
CA28	CAP CRMC 100NF 10% 50V X7R
CA29	CAP CRMC 100NF 10% 50V X7R
CA30	CAP CRMC 100NF 10% 50V X7R
CA31	CAP CRMC 100NF 10% 50V X7R
CA35	CAP CRMC 2N2 5% 50V NPO
DA01	BAV99 SM DIODE
DA02	BAV99 SM DIODE
DA03	BAV99 SM DIODE
DA04	DIODE SURFACE MOUNT BAS16
DA07	DIODE SURFACE MOUNT BAS16
DA08	DIODE SURFACE MOUNT BAS16
DA5-6	BAV99 SM DIODE
ICA1	OP275GS SM DUAL OPAMP
ICA2	TL072CD SM DUAL OP AMP
ICA3	TL072CD SM DUAL OP AMP
ICA4	TL072CD SM DUAL OP AMP
ICA5	TL072CD SM DUAL OP AMP
ICA6	TL072CD SM DUAL OP AMP
QA03	NPN TRANS BCW72
QA04	NPN TRANS BCW72
QA05	PNP TRANS BCW70
QA06	PNP TRANS BCW70
QA10	PNP TRANS BCW70
QA11	NPN TRANS BCW72
QA12	NPN TRANS BCW72
QA13	NPN TRANS BCW72
QA14	NPN TRANS BCW72
R181	SM0805 RES 12K 1% 0.1W T200
RA1	MMELF RES 100KJ 1% 0.2W 50BLF
RA2	MMELF RES 100KJ 1% 0.2W 50BLF
RA3	MMELF RES 47K 1% 0.2W 50BLF
RA4	MMELF RES 47K 1% 0.2W 50BLF
RA5	MMELF RES 220R 1% 0.2W 50BLF
RA6	MMELF RES 220R 1% 0.2W 50BLF
RA7	MMELF RES 1K 1% 0.2W 50BLF
RA8	MMELF RES 1K 1% 0.2W 50BLF
RA9	MMELF RES 820R 1% 0.2W 50BLF
RA10	MMELF RES 820R 1% 0.2W 50BLF
RA11	MMELF RES 10K 1% 0.2W 50BLF
RA12	MMELF RES 39R 1% 0.2W 50BLF
RA13	MMELF RES 33K 1% 0.2W 50BLF
RA14	MMELF RES 1K3 1% 0.2W 50BLF
RA15	MMELF RES 1K3 1% 0.2W 50BLF
RA16	MMELF RES 1K2 1% 0.2W 50BLF
RA17	MMELF RES 1K2 1% 0.2W 50BLF
RA18	MMELF RES 100KJ 1% 0.2W 50BLF
RA19	MMELF RES 130R 1% 0.2W 50BLF
RA20	MMELF RES 47K 1% 0.2W 50BLF
RA21	SM0805 RES 2K2 1% 0.1W T200
RA22	SM0805 RES 3K6 1% 0.1W T200
RA23	SM0805 RES 12K 1% 0.1W T200
RA24	SM0805 RES 12K 1% 0.1W T200
RA25	SM0805 RES 12K 1% 0.1W T200
RA26	SM0805 RES 18K 1% 0.1W T200
RA27	MMELF RES 47K 1% 0.2W 50BLF
RA28	SM0805 RES 75R 1% 0.1W T200
RA29	SM0805 RES 68K 1% 0.1W T200
RA30	SM0805 RES 68K 1% 0.1W T200
RA31	SM0805 RES 8K2 1% 0.1W T200
RA32	SM0805 RES 12K 1% 0.1W T200
RA33	SM0805 RES 12K 1% 0.1W T200

## RE4019A-SM

Part Number
SC4019-05
CS1101R-0805K
CS1101R-0805K
CS1220R-0805J
CS1220R-0805J
CS7104R-0805K
CS7104R-0805K
CS7104R-0805K
CS7104R-0805K
CS1222R-0805J
BS0005R-SOT23
BS0005R-SOT23
BS0005R-SOT23
BS0001R-SOT23
BS0001R-SOT23
BS0001R-SOT23
BS0005R-SOT23
BS7010R-SOIC8
BS7001R-SO8
BS7001R-SO8
BS7001R-SO8
BS7001R-SO8
BS7001R-SO8
BS0502R-SOT23
BS0502R-SOT23
BS0501R-SOT23
BS0501R-SOT23
BS0501R-SOT23
BS0502R-SOT23
BS0502R-SOT23
BS0502R-SOT23
BS0502R-SOT23
AS0123R-0805F
AS2104R-0102F
AS2104R-0102F
AS2473R-0102F
AS2473R-0102F
AS2221R-0102F
AS2221R-0102F
AS2102R-0102F
AS2102R-0102F
AS2821R-0102F
AS2821R-0102F
AS2103R-0102F
AS2390R-0102F
AS2333R-0102F
AS2132R-0102F
AS2132R-0102F
AS2122R-0102F
AS2122R-0102F
AS2104R-0102F
AS2131R-0102F
AS2473R-0102F
AS0222R-0805F
AS0362R-0805F
AS0123R-0805F
AS0123R-0805F
AS0123R-0805F
AS0183R-0805F
AS2473R-0102F
AS0750R-0805F
AS0683R-0805F
AS0683R-0805F
AS0822R-0805F
AS0123R-0805F
AS0123R-0805F

RA34 SM0805 RES 8K2 1% 0.1W T200  
 RA35 SM0805 RES 8K2 1% 0.1W T200  
 RA36 SM0805 RES 12K 1% 0.1W T200  
 RA37 SM0805 RES 12K 1% 0.1W T200  
 RA38 SM0805 RES 8K2 1% 0.1W T200  
 RA39 SM0805 RES 8K2 1% 0.1W T200  
 RA40 SM0805 RES 3K3 1% 0.1W T200  
 RA41 SM0805 RES 3K3 1% 0.1W T200  
 RA45 SM0805 RES 68K 1% 0.1W T200  
 RA46 SM0805 RES 4M7 1% 0.1W T200  
 RA47 SM0805 RES 22K 1% 0.1W T200  
 RA48 SM0805 RES 68K 1% 0.1W T200  
 RA49 SM0805 RES 4M7 1% 0.1W T200  
 RA50 MMELF RES 47K 1% 0.2W 50BLF  
 RA51 SM0805 RES 12K 1% 0.1W T200  
 RA52 SM0805 RES 12K 1% 0.1W T200  
 RA53 SM0805 RES 12K 1% 0.1W T200  
 RA54 SM0805 RES 12K 1% 0.1W T200  
 RA55 SM0805 RES 12K 1% 0.1W T200  
 RA56 SM0805 RES 12K 1% 0.1W T200  
 RA57 SM0805 RES 12K 1% 0.1W T200  
 RA58 SM0805 RES 12K 1% 0.1W T200  
 RA70 SM0805 RES 10R 1% 0.1W T200  
 RA71 MMELF RES 100KJ 1% 0.2W 50BLF  
 RA72 SM0805 RES 680K 1% 0.1W T200  
 RA73 SM0805 RES 68K 1% 0.1W T200  
 RA74 MMELF RES 10K 1% 0.2W 50BLF  
 RA75 SM0805 RES 330K 1% 0.1W T200  
 RA76 MMELF RES 100KJ 1% 0.2W 50BLF  
 RA77 SM0805 RES 22K 1% 0.1W T200  
 RA78 SM0805 RES 470K 1% 0.1W T200  
 RA79 SM0805 RES 470K 1% 0.1W T200  
 RA80 SM0805 RES 680K 1% 0.1W T200  
 RA81 SM0805 RES 4K7 1% 0.1W T200  
 RA82 SM0805 RES 680K 1% 0.1W T200  
 RA42-44 SM0805 RES 22K 1% 0.1W T200  
 RA59-69 SM0805 RES 22K 1% 0.1W T200

AS0822R-0805F  
 AS0822R-0805F  
 AS0123R-0805F  
 AS0123R-0805F  
 AS0822R-0805F  
 AS0822R-0805F  
 AS0332R-0805F  
 AS0332R-0805F  
 AS0683R-0805F  
 AS0475R-0805F  
 AS0223R-0805F  
 AS0683R-0805F  
 AS0475R-0805F  
 AS2473R-0102F  
 AS0123R-0805F  
 AS0123R-0805F  
 AS0123R-0805F  
 AS0123R-0805F  
 AS0123R-0805F  
 AS0123R-0805F  
 AS0123R-0805F  
 AS0123R-0805F  
 AS0123R-0805F  
 AS0100R-0805F  
 AS2104R-0102F  
 AS0684R-0805F  
 AS0683R-0805F  
 AS2103R-0102F  
 AS0334R-0805F  
 AS2104R-0102F  
 AS0223R-0805F  
 AS0474R-0805F  
 AS0474R-0805F  
 AS0684R-0805F  
 AS0472R-0805F  
 AS0684R-0805F  
 AS0223R-0805F  
 AS0223R-0805F

## MASTER PCB SM ASSY

Ident	Description
pcb	SERIES TWO MASTER PCB
C1	CAP CRMC 1NF 10% 50V X7R
C2	CAP CRMC 100PF 5% 50V NPO
C3	CAP CRMC 100PF 5% 50V NPO
C4	CAP CRMC 100PF 5% 50V NPO
C5	CAP CRMC 100PF 5% 50V NPO
C6	CAP CRMC 100PF 5% 50V NPO
C8	CAP CRMC 22PF 5% 50V NP0
C9	CAP CRMC 22PF 5% 50V NP0
C12	CAP CRMC 22PF 5% 50V NP0
C13	CAP CRMC 22PF 5% 50V NP0
C14	CAP CRMC 22PF 5% 50V NP0
C15	CAP CRMC 22PF 5% 50V NP0
C19	CAP CRMC 100PF 5% 50V NPO
C20	CAP CRMC 100PF 5% 50V NPO
C21	CAP CRMC 100PF 5% 50V NPO
C24	CAP CRMC 100NF 10% 50V X7R
C25	CAP CRMC 100NF 10% 50V X7R
C26	CAP CRMC 100NF 10% 50V X7R
C27	CAP CRMC 100NF 10% 50V X7R
C28	CAP CRMC 100PF 5% 50V NPO
C28	CAP CRMC 100NF 10% 50V X7R
C29	CAP CRMC 100NF 10% 50V X7R
C30	CAP CRMC 100NF 10% 50V X7R
C31	CAP CRMC 100NF 10% 50V X7R
C32	CAP CRMC 100NF 10% 50V X7R
C33	CAP CRMC 100NF 10% 50V X7R
C35	CAP CRMC 33PF 5% 50V NPO
C36	CAP CRMC 33PF 5% 50V NPO
C39	CAP CRMC 100PF 5% 50V NPO
C40	CAP CRMC 22PF 5% 50V NP0
C43	CAP CRMC 100NF 10% 50V X7R
C45	CAP CRMC 100PF 5% 50V NPO
C46	CAP CRMC 22PF 5% 50V NP0
C48	CAP CRMC 100PF 5% 50V NPO

## RF4020A-SM

Part Number
SC4020-06
CS7102R-0805K
CS1101R-0805J
CS1101R-0805J
CS1101R-0805J
CS1101R-0805J
CS1101R-0805J
CS1220R-0805J
CS1220R-0805J
CS1220R-0805J
CS1220R-0805J
CS1220R-0805J
CS1101R-0805J
CS1101R-0805J
CS1101R-0805J
CS7104R-0805K
CS7104R-0805K
CS7104R-0805K
CS1101R-0805J
CS7104R-0805K
CS7104R-0805K
CS7104R-0805K
CS1330R-0805J
CS1330R-0805J
CS1101R-0805J
CS1220R-0805J
CS7104R-0805K
CS1101R-0805J
CS1220R-0805J
CS1101R-0805J

C48	CAP CRMC 100NF 10% 50V X7R	CS7104R-0805K
C50	CAP CRMC 100PF 5% 50V NPO	CS1101R-0805J
C51	CAP CRMC 22PF 5% 50V NPO	CS1220R-0805J
C53	CAP CRMC 100NF 10% 50V X7R	CS7104R-0805K
C58	CAP CRMC 100NF 10% 50V X7R	CS7104R-0805K
C59	CAP CRMC 100PF 5% 50V NPO	CS1101R-0805J
C59	CAP CRMC 100NF 10% 50V X7R	CS7104R-0805K
C62	CAP CRMC 100NF 10% 50V X7R	CS7104R-0805K
C63	CAP CRMC 100NF 10% 50V X7R	CS7104R-0805K
C66	CAP CRMC 100NF 10% 50V X7R	CS7104R-0805K
C67	CAP CRMC 100NF 10% 50V X7R	CS7104R-0805K
C68	CAP CRMC 100PF 5% 50V NPO	CS1101R-0805J
C68	CAP CRMC 100NF 10% 50V X7R	CS7104R-0805K
C69	CAP CRMC 100NF 10% 50V X7R	CS7104R-0805K
C70	CAP CRMC 100NF 10% 50V X7R	CS7104R-0805K
C71	CAP CRMC 100NF 10% 50V X7R	CS7104R-0805K
C72	CAP CRMC 100NF 10% 50V X7R	CS7104R-0805K
C73	CAP CRMC 100NF 10% 50V X7R	CS7104R-0805K
C74	CAP CRMC 100NF 10% 50V X7R	CS7104R-0805K
C75	CAP CRMC 100NF 10% 50V X7R	CS7104R-0805K
C76	CAP CRMC 100NF 10% 50V X7R	CS7104R-0805K
C77	CAP CRMC 100NF 10% 50V X7R	CS7104R-0805K
C78	CAP CRMC 100NF 10% 50V X7R	CS7104R-0805K
C79	CAP CRMC 100NF 10% 50V X7R	CS7104R-0805K
C80	CAP CRMC 100NF 10% 50V X7R	CS7104R-0805K
C81	CAP CRMC 100NF 10% 50V X7R	CS7104R-0805K
C84	CAP CRMC 10NF 10% 50V X7R	CS7103R-0805K
C85	CAP CRMC 10NF 10% 50V X7R	CS7103R-0805K
C86	CAP CRMC 680PF 5% 50V	CS1681R-0805J
C87	CAP CRMC 680PF 5% 50V	CS1681R-0805J
C88	CAP CRMC 100PF 5% 50V NPO	CS1101R-0805J
C93	CAP CRMC 100NF 10% 50V X7R	CS7104R-0805K
C94	CAP CRMC 100NF 10% 50V X7R	CS7104R-0805K
C96	CAP CRMC 100NF 10% 50V X7R	CS7104R-0805K
CA1	CAP CRMC 100PF 5% 50V NPO	CS1101R-0805J
CA3	CAP CRMC 22PF 5% 50V NPO	CS1220R-0805J
CA5	CAP CRMC 100PF 5% 50V NPO	CS1101R-0805J
CA7	CAP CRMC 22PF 5% 50V NPO	CS1220R-0805J
CA9	CAP CRMC 100NF 10% 50V X7R	CS7104R-0805K
CA11	CAP CRMC 100PF 5% 50V NPO	CS1101R-0805J
CA12	CAP CRMC 22PF 5% 50V NPO	CS1220R-0805J
CA16	CAP CRMC 100PF 5% 50V NPO	CS1101R-0805J
CA17	CAP CRMC 22PF 5% 50V NPO	CS1220R-0805J
CA20	CAP CRMC 100NF 10% 50V X7R	CS7104R-0805K
CC40	CAP CRMC 100NF 10% 50V X7R	CS7104R-0805K
CC60	CAP CRMC 100NF 10% 50V X7R	CS7104R-0805K
CC80	CAP CRMC 100NF 10% 50V X7R	CS7104R-0805K
CR1	CAP CRMC 22PF 5% 50V NPO	CS1220R-0805J
CR2	CAP CRMC 22PF 5% 50V NPO	CS1220R-0805J
CR7	CAP CRMC 22PF 5% 50V NPO	CS1220R-0805J
CR10	CAP CRMC 100PF 5% 50V NPO	CS1101R-0805J
CR11	CAP CRMC 22PF 5% 50V NPO	CS1220R-0805J
CR12	CAP CRMC 22PF 5% 50V NPO	CS1220R-0805J
CR17	CAP CRMC 22PF 5% 50V NPO	CS1220R-0805J
CR21	CAP CRMC 22PF 5% 50V NPO	CS1220R-0805J
CR22	CAP CRMC 22PF 5% 50V NPO	CS1220R-0805J
CR27	CAP CRMC 22PF 5% 50V NPO	CS1220R-0805J
CR30	CAP CRMC 100PF 5% 50V NPO	CS1101R-0805J
CR31	CAP CRMC 22PF 5% 50V NPO	CS1220R-0805J
CR32	CAP CRMC 22PF 5% 50V NPO	CS1220R-0805J
CR37	CAP CRMC 22PF 5% 50V NPO	CS1220R-0805J
CR41	CAP CRMC 22PF 5% 50V NPO	CS1220R-0805J
CR42	CAP CRMC 22PF 5% 50V NPO	CS1220R-0805J
CR47	CAP CRMC 22PF 5% 50V NPO	CS1220R-0805J
CR50	CAP CRMC 100PF 5% 50V NPO	CS1101R-0805J
CR51	CAP CRMC 22PF 5% 50V NPO	CS1220R-0805J
CR52	CAP CRMC 22PF 5% 50V NPO	CS1220R-0805J
CR57	CAP CRMC 22PF 5% 50V NPO	CS1220R-0805J
CR61	CAP CRMC 22PF 5% 50V NPO	CS1220R-0805J
CR62	CAP CRMC 22PF 5% 50V NPO	CS1220R-0805J
CR67	CAP CRMC 22PF 5% 50V NPO	CS1220R-0805J
CR70	CAP CRMC 100PF 5% 50V NPO	CS1101R-0805J
CR71	CAP CRMC 22PF 5% 50V NPO	CS1220R-0805J
CR72	CAP CRMC 22PF 5% 50V NPO	CS1220R-0805J
CR77	CAP CRMC 22PF 5% 50V NPO	CS1220R-0805J
CS1	CAP CRMC 22PF 5% 50V NPO	CS1220R-0805J

CS2	CAP CRMC 22PF 5% 50V NP0	CS1220R-0805J
CS8	CAP CRMC 100PF 5% 50V NP0	CS1101R-0805J
CS20	CAP CRMC 100NF 10% 50V X7R	CS7104R-0805K
CS21	CAP CRMC 22PF 5% 50V NP0	CS1220R-0805J
CS22	CAP CRMC 22PF 5% 50V NP0	CS1220R-0805J
CS41	CAP CRMC 22PF 5% 50V NP0	CS1220R-0805J
CS42	CAP CRMC 22PF 5% 50V NP0	CS1220R-0805J
CS61	CAP CRMC 22PF 5% 50V NP0	CS1220R-0805J
CS62	CAP CRMC 22PF 5% 50V NP0	CS1220R-0805J
D1	DIODE SURFACE MOUNT BAS16	BS0001R-SOT23
D2	DIODE SURFACE MOUNT BAS16	BS0001R-SOT23
D3	DIODE SURFACE MOUNT BAS16	BS0001R-SOT23
D4	3BAV99 SM DIODE	BS0005R-SOT23
D5	DIODE SURFACE MOUNT BAS16	BS0001R-SOT23
DR1-8	3BAV99 SM DIODE	BS0005R-SOT23
DS1-4	3BAV99 SM DIODE	BS0005R-SOT23
DZ1	ZENER DIODE 300MW 5VI BZX84C	BS0020R-SOT23
IC1	TL072CD SM DUAL OP AMP	BS7001R-SO8
IC2	TL072CD SM DUAL OP AMP	BS7001R-SO8
IC3	TL072CD SM DUAL OP AMP	BS7001R-SO8
IC4	TL072CD SM DUAL OP AMP	BS7001R-SO8
IC5	TL072CD SM DUAL OP AMP	BS7001R-SO8
IC6	NE5532 SM DUAL OP AMP	BS7009R-SO8
IC7	NE5532 SM DUAL OP AMP	BS7009R-SO8
IC8	74HC4053 SM TP 2CH MUX/DEMUX	BS2513R-SO16
IC9	74HC4053 SM TP 2CH MUX/DEMUX	BS2513R-SO16
IC10	NE5532 SM DUAL OP AMP	BS7009R-SO8
IC11	TL072CD SM DUAL OP AMP	BS7001R-SO8
IC12	NE5532 SM DUAL OP AMP	BS7009R-SO8
IC13	NE5532 SM DUAL OP AMP	BS7009R-SO8
IC14	NE5532 SM DUAL OP AMP	BS7009R-SO8
IC15	TL072CD SM DUAL OP AMP	BS7001R-SO8
IC16	DRV135 BAL LINE DRIVER SM	BS7015M-SO8
IC18	DRV135 BAL LINE DRIVER SM	BS7015M-SO8
IC20	DRV135 BAL LINE DRIVER SM	BS7015M-SO8
IC21	74HC4094 SM 8-STG SHFT/STORE	BS2519R
IC23	74HC4094 SM 8-STG SHFT/STORE	BS2519R
IC25	HCF4099B 8BIT ADD/LATCH	BS1113R-SO16
IC27	74HC4051 8-I ANALOG MUX SM	BS2511R-SO16
IC29	74HC4051 8-I ANALOG MUX SM	BS2511R-SO16
IC31	HCF4099B 8BIT ADD/LATCH	BS1113R-SO16
ICA1	NE5532 SM DUAL OP AMP	BS7009R-SO8
ICA2	TL072CD SM DUAL OP AMP	BS7001R-SO8
ICA3	NE5532 SM DUAL OP AMP	BS7009R-SO8
ICA4	TL072CD SM DUAL OP AMP	BS7001R-SO8
ICR1	TL072CD SM DUAL OP AMP	BS7001R-SO8
ICR2	TL072CD SM DUAL OP AMP	BS7001R-SO8
ICR3	TL072CD SM DUAL OP AMP	BS7001R-SO8
ICR4	TL072CD SM DUAL OP AMP	BS7001R-SO8
ICR5	TL072CD SM DUAL OP AMP	BS7001R-SO8
ICR6	TL072CD SM DUAL OP AMP	BS7001R-SO8
ICR7	TL072CD SM DUAL OP AMP	BS7001R-SO8
ICR8	TL072CD SM DUAL OP AMP	BS7001R-SO8
ICR9	TL072CD SM DUAL OP AMP	BS7001R-SO8
ICR10	TL072CD SM DUAL OP AMP	BS7001R-SO8
ICR11	TL072CD SM DUAL OP AMP	BS7001R-SO8
ICR12	TL072CD SM DUAL OP AMP	BS7001R-SO8
ICS1	TL072CD SM DUAL OP AMP	BS7001R-SO8
ICS2	TL072CD SM DUAL OP AMP	BS7001R-SO8
ICS3	TL072CD SM DUAL OP AMP	BS7001R-SO8
ICS4	TL072CD SM DUAL OP AMP	BS7001R-SO8
ICS5	TL072CD SM DUAL OP AMP	BS7001R-SO8
ICS6	TL072CD SM DUAL OP AMP	BS7001R-SO8
ICS7	TL072CD SM DUAL OP AMP	BS7001R-SO8
ICS8	TL072CD SM DUAL OP AMP	BS7001R-SO8
ICS9	TL072CD SM DUAL OP AMP	BS7001R-SO8
ICS10	TL072CD SM DUAL OP AMP	BS7001R-SO8
ICS11	TL072CD SM DUAL OP AMP	BS7001R-SO8
ICS12	TL072CD SM DUAL OP AMP	BS7001R-SO8
Q6	NPN TRANS BCW72	BS0502R-SOT23
Q7	NPN TRANS BCW72	BS0502R-SOT23
Q16	NPN TRANS BCW72	BS0502R-SOT23
Q17	NPN TRANS BCW72	BS0502R-SOT23
QR5	PNP TRANS BCW70	BS0501R-SOT23
QR6	NPN TRANS BCW72	BS0502R-SOT23
QR7	NPN TRANS BCW72	BS0502R-SOT23



QR15	PNP TRANS BCW70	BS0501R-SOT23
QR16	NPN TRANS BCW72	BS0502R-SOT23
QR17	NPN TRANS BCW72	BS0502R-SOT23
QR25	PNP TRANS BCW70	BS0501R-SOT23
QR26	NPN TRANS BCW72	BS0502R-SOT23
QR27	NPN TRANS BCW72	BS0502R-SOT23
QR35	PNP TRANS BCW70	BS0501R-SOT23
QR36	NPN TRANS BCW72	BS0502R-SOT23
QR37	NPN TRANS BCW72	BS0502R-SOT23
QS5	PNP TRANS BCW70	BS0501R-SOT23
QS15	PNP TRANS BCW70	BS0501R-SOT23
R1	SM0805 RES 4M7 1% 0.1W T200	AS0475R-0805F
R2	SM0805 RES 68K 1% 0.1W T200	AS0683R-0805F
R3	SM0805 RES 22K 1% 0.1W T200	AS0223R-0805F
R4	SM0805 RES 100K 1% 0.1W T200	AS0104R-0805F
R5	SM0805 RES 22K 1% 0.1W T200	AS0223R-0805F
R6	SM0805 RES 100K 1% 0.1W T200	AS0104R-0805F
R7	SM0805 RES 3K6 1% 0.1W T200	AS0362R-0805F
R8	SM0805 RES 1K5 1% 0.1W T200	AS0152R-0805F
R9	SM0805 RES 12K 1% 0.1W T200	AS0123R-0805F
R10	SM0805 RES 100K 1% 0.1W T200	AS0104R-0805F
R11	SM0805 RES 330K 1% 0.1W T200	AS0334R-0805F
R12	SM0805 RES 3K3 1% 0.1W T200	AS0332R-0805F
R13	SM0805 RES 1K5 1% 0.1W T200	AS0152R-0805F
R14	SM0805 RES 24K 1% 0.1W T200	AS0243R-0805F
R15	SM0805 RES 24K 1% 0.1W T200	AS0243R-0805F
R16	SM0805 RES 22K 1% 0.1W T200	AS0223R-0805F
R17	SM0805 RES 22K 1% 0.1W T200	AS0223R-0805F
R18	SM0805 RES 22K 1% 0.1W T200	AS0223R-0805F
R19	SM0805 RES 30K 1% 0.1W T200	AS0303R-0805F
R20	SM0805 RES 30K 1% 0.1W T200	AS0303R-0805F
R21	SM0805 RES 30K 1% 0.1W T200	AS0303R-0805F
R22	SM0805 RES 30K 1% 0.1W T200	AS0303R-0805F
R23	SM0805 RES 30K 1% 0.1W T200	AS0303R-0805F
R24	SM0805 RES 24K 1% 0.1W T200	AS0243R-0805F
R25	SM0805 RES 24K 1% 0.1W T200	AS0243R-0805F
R26	SM0805 RES 33K 1% 0.1W T200	AS0333R-0805F
R27	SM0805 RES 33K 1% 0.1W T200	AS0333R-0805F
R28	SM0805 RES 24K 1% 0.1W T200	AS0243R-0805F
R29	SM0805 RES 24K 1% 0.1W T200	AS0243R-0805F
R30	SM0805 RES 1K2 1% 0.1W T200	AS0122R-0805F
R31	SM0805 RES 1K2 1% 0.1W T200	AS0122R-0805F
R32	SM0805 RES 12K 1% 0.1W T200	AS0123R-0805F
R33	SM0805 RES 12K 1% 0.1W T200	AS0123R-0805F
R34	SM0805 RES 47K 1% 0.1W T200	AS0473R-0805F
R35	SM0805 RES 47K 1% 0.1W T200	AS0473R-0805F
R36	SM0805 RES 24K 1% 0.1W T200	AS0243R-0805F
R37	SM0805 RES 24K 1% 0.1W T200	AS0243R-0805F
R38	SM0805 RES 75R 1% 0.1W T200	AS0750R-0805F
R39	SM0805 RES 75R 1% 0.1W T200	AS0750R-0805F
R40	SM0805 RES 12K 1% 0.1W T200	AS0123R-0805F
R41	SM0805 RES 12K 1% 0.1W T200	AS0123R-0805F
R42	SM0805 RES 12K 1% 0.1W T200	AS0123R-0805F
R43	SM0805 RES 12K 1% 0.1W T200	AS0123R-0805F
R44	SM0805 RES 100K 1% 0.1W T200	AS0104R-0805F
R45	SM0805 RES 100K 1% 0.1W T200	AS0104R-0805F
R46	SM0805 RES 100K 1% 0.1W T200	AS0104R-0805F
R47	SM0805 RES 100K 1% 0.1W T200	AS0104R-0805F
R48	SM0805 RES 10R 1% 0.1W T200	AS0100R-0805F
R49	SM0805 RES 10R 1% 0.1W T200	AS0100R-0805F
R50	SM0805 RES 10R 1% 0.1W T200	AS0100R-0805F
R51	SM0805 RES 10R 1% 0.1W T200	AS0100R-0805F
R52	SM0805 RES 2K2 1% 0.1W T200	AS0222R-0805F
R53	SM0805 RES 2K2 1% 0.1W T200	AS0222R-0805F
R54	SM0805 RES 2K2 1% 0.1W T200	AS0222R-0805F
R55	SM0805 RES 2K2 1% 0.1W T200	AS0222R-0805F
R56	SM0805 RES 22K 1% 0.1W T200	AS0223R-0805F
R57	SM0805 RES 22K 1% 0.1W T200	AS0223R-0805F
R58	SM0805 RES 22K 1% 0.1W T200	AS0223R-0805F
R59	SM0805 RES 22K 1% 0.1W T200	AS0223R-0805F
R60	SM0805 RES 22K 1% 0.1W T200	AS0223R-0805F
R61	SM0805 RES 22K 1% 0.1W T200	AS0223R-0805F
R62	SM0805 RES 10R 1% 0.1W T200	AS0100R-0805F
R63	SM0805 RES 10R 1% 0.1W T200	AS0100R-0805F
R64	SM0805 RES 24K 1% 0.1W T200	AS0243R-0805F
R65	SM0805 RES 24K 1% 0.1W T200	AS0243R-0805F

R66	SM0805 RES 24K 1% 0.1W T200	AS0243R-0805F
R67	SM0805 RES 24K 1% 0.1W T200	AS0243R-0805F
R68	SM0805 RES 24K 1% 0.1W T200	AS0243R-0805F
R69	SM0805 RES 24K 1% 0.1W T200	AS0243R-0805F
R70	SM0805 RES 24K 1% 0.1W T200	AS0243R-0805F
R71	SM0805 RES 24K 1% 0.1W T200	AS0243R-0805F
R72	SM0805 RES 24K 1% 0.1W T200	AS0243R-0805F
R73	SM0805 RES 24K 1% 0.1W T200	AS0243R-0805F
R74	SM0805 RES 24K 1% 0.1W T200	AS0243R-0805F
R75	SM0805 RES 24K 1% 0.1W T200	AS0243R-0805F
R76	SM0805 RES 24K 1% 0.1W T200	AS0243R-0805F
R77	SM0805 RES 24K 1% 0.1W T200	AS0243R-0805F
R78	SM0805 RES 24K 1% 0.1W T200	AS0243R-0805F
R79	SM0805 RES 24K 1% 0.1W T200	AS0243R-0805F
R80	SM0805 RES 24K 1% 0.1W T200	AS0243R-0805F
R81	SM0805 RES 24K 1% 0.1W T200	AS0243R-0805F
R82	SM0805 RES 24K 1% 0.1W T200	AS0243R-0805F
R83	SM0805 RES 24K 1% 0.1W T200	AS0243R-0805F
R84	SM0805 RES 24K 1% 0.1W T200	AS0243R-0805F
R85	SM0805 RES 24K 1% 0.1W T200	AS0243R-0805F
R86	SM0805 RES 24K 1% 0.1W T200	AS0243R-0805F
R87	SM0805 RES 24K 1% 0.1W T200	AS0243R-0805F
R88	SM0805 RES 24K 1% 0.1W T200	AS0243R-0805F
R89	SM0805 RES 24K 1% 0.1W T200	AS0243R-0805F
R90	SM0805 RES 24K 1% 0.1W T200	AS0243R-0805F
R91	SM0805 RES 24K 1% 0.1W T200	AS0243R-0805F
R92	SM0805 RES 24K 1% 0.1W T200	AS0243R-0805F
R93	SM0805 RES 24K 1% 0.1W T200	AS0243R-0805F
R94	SM0805 RES 24K 1% 0.1W T200	AS0243R-0805F
R95	SM0805 RES 24K 1% 0.1W T200	AS0243R-0805F
R96	SM0805 RES 12K 1% 0.1W T200	AS0123R-0805F
R97	SM0805 RES 12K 1% 0.1W T200	AS0123R-0805F
R98	SM0805 RES 12K 1% 0.1W T200	AS0123R-0805F
R99	SM0805 RES 12K 1% 0.1W T200	AS0123R-0805F
R100	SM0805 RES 12K 1% 0.1W T200	AS0123R-0805F
R101	SM0805 RES 12K 1% 0.1W T200	AS0123R-0805F
R102	SM0805 RES 24K 1% 0.1W T200	AS0243R-0805F
R103	SM0805 RES 24K 1% 0.1W T200	AS0243R-0805F
R104	SM0805 RES 330R 1% 0.1W T200	AS0331R-0805F
R105	SM0805 RES 330R 1% 0.1W T200	AS0331R-0805F
R106	SM0805 RES 12K 1% 0.1W T200	AS0123R-0805F
R107	SM0805 RES 12K 1% 0.1W T200	AS0123R-0805F
R108	SM0805 RES 12K 1% 0.1W T200	AS0123R-0805F
R109	SM0805 RES 12K 1% 0.1W T200	AS0123R-0805F
R110	SM0805 RES 75R 1% 0.1W T200	AS0750R-0805F
R111	SM0805 RES 75R 1% 0.1W T200	AS0750R-0805F
R112	SM0805 RES 36K 1% 0.1W T200	AS0363R-0805F
R113	SM0805 RES 36K 1% 0.1W T200	AS0363R-0805F
R114	SM0805 RES 100K 1% 0.1W T200	AS0104R-0805F
R115	SM0805 RES 100K 1% 0.1W T200	AS0104R-0805F
R116	SM0805 RES 330R 1% 0.1W T200	AS0331R-0805F
R117	SM0805 RES 47K 1% 0.1W T200	AS0473R-0805F
R118	SM0805 RES 20K 1% 0.1W T200	AS0203R-0805F
R119	SM0805 RES 10K 1% 0.1W T200	AS0103R-0805F
R120	SM0805 RES 4K7 1% 0.1W T200	AS0472R-0805F
R121	SM0805 RES 20K 1% 0.1W T200	AS0203R-0805F
R122	SM0805 RES 4K7 1% 0.1W T200	AS0472R-0805F
R123	SM0805 RES 4K7 1% 0.1W T200	AS0472R-0805F
R124	SM0805 RES 10K 1% 0.1W T200	AS0103R-0805F
R125	SM0805 RES 10K 1% 0.1W T200	AS0103R-0805F
R126	SM0805 RES 24K 1% 0.1W T200	AS0243R-0805F
R127	SM0805 RES 24K 1% 0.1W T200	AS0243R-0805F
R128	SM0805 RES 22K 1% 0.1W T200	AS0223R-0805F
R129	SM0805 RES 12K 1% 0.1W T200	AS0123R-0805F
R130	SM0805 RES 12K 1% 0.1W T200	AS0123R-0805F
R131	SM0805 RES 22K 1% 0.1W T200	AS0223R-0805F
R132	SM0805 RES 22K 1% 0.1W T200	AS0223R-0805F
R133	SM0805 RES 75R 1% 0.1W T200	AS0750R-0805F
R134	SM0805 RES 22K 1% 0.1W T200	AS0223R-0805F
R135	SM0805 RES 12K 1% 0.1W T200	AS0123R-0805F
R136	SM0805 RES 12K 1% 0.1W T200	AS0123R-0805F
R137	SM0805 RES 22K 1% 0.1W T200	AS0223R-0805F
R138	SM0805 RES 22K 1% 0.1W T200	AS0223R-0805F
R139	SM0805 RES 75R 1% 0.1W T200	AS0750R-0805F
R140	SM0805 RES 22K 1% 0.1W T200	AS0223R-0805F
R141	SM0805 RES 12K 1% 0.1W T200	AS0123R-0805F

R142	SM0805 RES 12K 1% 0.1W T200	AS0123R-0805F
R143	SM0805 RES 22K 1% 0.1W T200	AS0223R-0805F
R144	SM0805 RES 22K 1% 0.1W T200	AS0223R-0805F
R145	SM0805 RES 75R 1% 0.1W T200	AS0750R-0805F
R146	SM0805 RES 10K 1% 0.1W T200	AS0103R-0805F
R147	SM0805 RES 5K1 1% 0.1W T200	AS0512R-0805F
R148	SM0805 RES 5K1 1% 0.1W T200	AS0512R-0805F
R149	SM0805 RES 15K 1% 0.1W T200	AS0153R-0805F
R156	SM0805 RES 8K2 1% 0.1W T200	AS0822R-0805F
R157	SM0805 RES 360R 1% 0.1W T200	AS0361R-0805F
R158	SM0805 RES 0R 1% 0.1W T200	AS0000R-0805F
R159	SM0805 RES 100K 1% 0.1W T200	AS0104R-0805F
R162	SM0805 RES 10R 1% 0.1W T200	AS0100R-0805F
R163	SM0805 RES 100K 1% 0.1W T200	AS0104R-0805F
R164	SM0805 RES 100K 1% 0.1W T200	AS0104R-0805F
R165	SM0805 RES 100K 1% 0.1W T200	AS0104R-0805F
R166	SM0805 RES 100K 1% 0.1W T200	AS0104R-0805F
R167	SM0805 RES 100K 1% 0.1W T200	AS0104R-0805F
R168	SM0805 RES 100K 1% 0.1W T200	AS0104R-0805F
R169	SM0805 RES 470R 1% 0.1W T200	AS0471R-0805F
R170	SM0805 RES 470R 1% 0.1W T200	AS0471R-0805F
R171	SM0805 RES 100K 1% 0.1W T200	AS0104R-0805F
R172	SM0805 RES 100K 1% 0.1W T200	AS0104R-0805F
R173	SM0805 RES 100K 1% 0.1W T200	AS0104R-0805F
R174	SM0805 RES 470R 1% 0.1W T200	AS0471R-0805F
R175	SM0805 RES 470R 1% 0.1W T200	AS0471R-0805F
R176	SM0805 RES 100K 1% 0.1W T200	AS0104R-0805F
R177	SM0805 RES 100K 1% 0.1W T200	AS0104R-0805F
R178	SM0805 RES 100K 1% 0.1W T200	AS0104R-0805F
R179	SM0805 RES 470R 1% 0.1W T200	AS0471R-0805F
R180	SM0805 RES 470R 1% 0.1W T200	AS0471R-0805F
R181	SM0805 RES 470R 1% 0.1W T200	AS0471R-0805F
R182	SM0805 RES 470R 1% 0.1W T200	AS0471R-0805F
R183	SM0805 RES 470R 1% 0.1W T200	AS0471R-0805F
R184	SM0805 RES 470R 1% 0.1W T200	AS0471R-0805F
R185	SM0805 RES 470R 1% 0.1W T200	AS0471R-0805F
R186	SM0805 RES 470R 1% 0.1W T200	AS0471R-0805F
R187	SM0805 RES 470R 1% 0.1W T200	AS0471R-0805F
R188	SM0805 RES 470R 1% 0.1W T200	AS0471R-0805F
R189	SM0805 RES 470R 1% 0.1W T200	AS0471R-0805F
R190	SM0805 RES 4K7 1% 0.1W T200	AS0472R-0805F
R191	SM0805 RES 4K7 1% 0.1W T200	AS0472R-0805F
R192	SM0805 RES 4K7 1% 0.1W T200	AS0472R-0805F
R193	SM0805 RES 4K7 1% 0.1W T200	AS0472R-0805F
R194	SM0805 RES 10K 1% 0.1W T200	AS0103R-0805F
R195	SM0805 RES 2K 1% 0.1W T200	AS0202R-0805F
R196	SM0805 RES 8K2 1% 0.1W T200	AS0822R-0805F
R197	SM0805 RES 75R 1% 0.1W T200	AS0750R-0805F
R198	SM0805 RES 22K 1% 0.1W T200	AS0223R-0805F
R199	SM0805 RES 22K 1% 0.1W T200	AS0223R-0805F
R200	SM0805 RES 2K2 1% 0.1W T200	AS0222R-0805F
R201	SM0805 RES 12K 1% 0.1W T200	AS0123R-0805F
R202	SM0805 RES 68K 1% 0.1W T200	AS0683R-0805F
R203	SM0805 RES 680R 1% 0.1W T200	AS0681R-0805F
R204	SM0805 RES 12K 1% 0.1W T200	AS0123R-0805F
R205	SM0805 RES 5K1 1% 0.1W T200	AS0512R-0805F
R207	SM0805 RES 10R 1% 0.1W T200	AS0100R-0805F
R208	SM0805 RES 2K2 1% 0.1W T200	AS0222R-0805F
R209	SM0805 RES 4K3 1% 0.1W T200	AS0432R-0805F
R210	SM0805 RES 47K 1% 0.1W T200	AS0473R-0805F
R211	SM0805 RES 0R 1% 0.1W T200	AS0000R-0805F
R212	SM0805 RES 0R 1% 0.1W T200	AS0000R-0805F
RA1	SM0805 RES 6K8 1% 0.1W T200	AS0682R-0805F
RA2	SM0805 RES 6K8 1% 0.1W T200	AS0682R-0805F
RA3	SM0805 RES 56K 1% 0.1W T200	AS0563R-0805F
RA4	SM0805 RES 22K 1% 0.1W T200	AS0223R-0805F
RA5	SM0805 RES 75R 1% 0.1W T200	AS0750R-0805F
RA6	SM0805 RES 36K 1% 0.1W T200	AS0363R-0805F
RA7	SM0805 RES 100K 1% 0.1W T200	AS0104R-0805F
RA8	SM0805 RES 6K8 1% 0.1W T200	AS0682R-0805F
RA9	SM0805 RES 6K8 1% 0.1W T200	AS0682R-0805F
RA10	SM0805 RES 56K 1% 0.1W T200	AS0563R-0805F
RA11	SM0805 RES 22K 1% 0.1W T200	AS0223R-0805F
RA12	SM0805 RES 75R 1% 0.1W T200	AS0750R-0805F
RA13	SM0805 RES 36K 1% 0.1W T200	AS0363R-0805F
RA14	SM0805 RES 100K 1% 0.1W T200	AS0104R-0805F















R11 SM0805 RES 12K 1% 0.1W T200  
 R12 SM0805 RES 24K 1% 0.1W T200  
 R13 SM0805 RES 470R 1% 0.1W T200  
 R14 SM0805 RES 470R 1% 0.1W T200  
 R15 SM0805 RES 8K2 1% 0.1W T200  
 R16 SM0805 RES 470R 1% 0.1W T200  
 R17 SM0805 RES 2K2 1% 0.1W T200  
 R18 SM0805 RES 47K 1% 0.1W T200  
 R19 SM0805 RES 2K 1% 0.1W T200  
 R20 SM0805 RES 100K 1% 0.1W T200  
 R21 SM0805 RES 100K 1% 0.1W T200  
 R22 SM0805 RES 47K 1% 0.1W T200  
 R23 SM0805 RES 47K 1% 0.1W T200  
 R24 SM0805 RES 47K 1% 0.1W T200  
 R25 SM0805 RES 47K 1% 0.1W T200  
 R26 SM0805 RES 47K 1% 0.1W T200  
 R27 SM0805 RES 47K 1% 0.1W T200  
 R28 SM0805 RES 47K 1% 0.1W T200  
 R29 SM0805 RES 47K 1% 0.1W T200  
 R30 SM0805 RES 47K 1% 0.1W T200  
 R31 SM0805 RES 47K 1% 0.1W T200  
 R32 SM0805 RES 100R 1% 0.1W T200  
 R33 SM0805 RES 100R 1% 0.1W T200  
 RA1 SM0805 RES 10K 1% 0.1W T200  
 RA2 SM0805 RES 10K 1% 0.1W T200  
 RA3 SM0805 RES 22K 1% 0.1W T200  
 RA4 SM0805 RES 22K 1% 0.1W T200  
 RA5 SM0805 RES 100K 1% 0.1W T200  
 RA6 SM0805 RES 100K 1% 0.1W T200  
 RA7 SM0805 RES 100R 1% 0.1W T200  
 RA8 SM0805 RES 100R 1% 0.1W T200  
 RA9 SM0805 RES 470R 1% 0.1W T200  
 RA10 SM0805 RES 470R 1% 0.1W T200  
 RA11 SM0805 RES 1M 1% 0.1W T200  
 RA12 SM0805 RES 1M 1% 0.1W T200  
 RA13 SM0805 RES 20K 1% 0.1W T200  
 RA14 SM0805 RES 20K 1% 0.1W T200  
 RA15 SM0805 RES 20K 1% 0.1W T200  
 RA16 SM0805 RES 20K 1% 0.1W T200  
 RA17 SM0805 RES 33K 1% 0.1W T200  
 RA18 SM0805 RES 33K 1% 0.1W T200  
 RA19 SM0805 RES 33K 1% 0.1W T200  
 RA20 SM0805 RES 33K 1% 0.1W T200  
 RA21 SM0805 RES 51K 1% 0.1W T200  
 RA22 SM0805 RES 51K 1% 0.1W T200  
 RA23 SM0805 RES 51K 1% 0.1W T200  
 RA24 SM0805 RES 51K 1% 0.1W T200  
 RA25 SM0805 RES 22K 1% 0.1W T200  
 RA26 SM0805 RES 22K 1% 0.1W T200  
 RA27 SM0805 RES 100K 1% 0.1W T200  
 RA28 SM0805 RES 100K 1% 0.1W T200  
 RA29 SM0805 RES 470R 1% 0.1W T200  
 RA30 SM0805 RES 470R 1% 0.1W T200  
 RA31 SM0805 RES 2K2 1% 0.1W T200  
 RA32 SM0805 RES 2K2 1% 0.1W T200  
 RA33 SM0805 RES 56K 1% 0.1W T200  
 RA34 SM0805 RES 56K 1% 0.1W T200  
 RA35 SM0805 RES 22K 1% 0.1W T200  
 RA36 SM0805 RES 22K 1% 0.1W T200

AS0123R-0805F  
 AS0243R-0805F  
 AS0471R-0805F  
 AS0471R-0805F  
 AS0822R-0805F  
 AS0471R-0805F  
 AS0222R-0805F  
 AS0473R-0805F  
 AS0202R-0805F  
 AS0104R-0805F  
 AS0104R-0805F  
 AS0473R-0805F  
 AS0473R-0805F  
 AS0473R-0805F  
 AS0473R-0805F  
 AS0473R-0805F  
 AS0473R-0805F  
 AS0473R-0805F  
 AS0473R-0805F  
 AS0473R-0805F  
 AS0473R-0805F  
 AS0101R-0805F  
 AS0101R-0805F  
 AS0103R-0805F  
 AS0103R-0805F  
 AS0223R-0805F  
 AS0223R-0805F  
 AS0104R-0805F  
 AS0104R-0805F  
 AS0101R-0805F  
 AS0101R-0805F  
 AS0471R-0805F  
 AS0471R-0805F  
 AS0105R-0805F  
 AS0105R-0805F  
 AS0203R-0805F  
 AS0203R-0805F  
 AS0203R-0805F  
 AS0203R-0805F  
 AS0333R-0805F  
 AS0333R-0805F  
 AS0333R-0805F  
 AS0333R-0805F  
 AS0513R-0805F  
 AS0513R-0805F  
 AS0513R-0805F  
 AS0513R-0805F  
 AS0223R-0805F  
 AS0223R-0805F  
 AS0104R-0805F  
 AS0104R-0805F  
 AS0471R-0805F  
 AS0471R-0805F  
 AS0222R-0805F  
 AS0222R-0805F  
 AS0563R-0805F  
 AS0563R-0805F  
 AS0223R-0805F  
 AS0223R-0805F

### O/P MTR PCB SM ASSY

Ident	Description
pcb	SERIES TWO O/P MTR PCB
C1	CAP CRMC 100NF 10% 50V X7R
C2	CAP CRMC 100NF 10% 50V X7R
C3	CAP CRMC 100NF 10% 50V X7R
C4	CAP CRMC 100NF 10% 50V X7R
C5	CAP CRMC 100PF 5% 50V NPO
C6	TANT CAP 10UF 10V CASE B
C7	CAP CRMC 100NF 10% 50V X7R
C8	CAP CRMC 100NF 10% 50V X7R
C9	CAP CRMC 100NF 10% 50V X7R
C10	CAP CRMC 100NF 10% 50V X7R
C11	CAP CRMC 100NF 10% 50V X7R
C12	CAP CRMC 100PF 5% 50V NPO

### RF4027A-SM

Part Number
SC4027-06
CS7104R-0805K
CS7104R-0805K
CS7104R-0805K
CS7104R-0805K
CS1101R-0805J
CS3106R-CASBK
CS7104R-0805K
CS7104R-0805K
CS7104R-0805K
CS7104R-0805K
CS7104R-0805K
CS1101R-0805J

C13	CAP CRMC 100NF 10% 50V X7R	CS7104R-0805K
C15	CAP CRMC 100NF 10% 50V X7R	CS7104R-0805K
C16	CAP CRMC 100NF 10% 50V X7R	CS7104R-0805K
C17	CAP CRMC 100NF 10% 50V X7R	CS7104R-0805K
C18	CAP CRMC 100NF 10% 50V X7R	CS7104R-0805K
C19	CAP CRMC 100PF 5% 50V NPO	CS1101R-0805J
C20	CAP CRMC 10NF 10% 50V X7R	CS7103R-0805K
C21	CAP CRMC 100NF 10% 50V X7R	CS7104R-0805K
CA3	SM TANT CAP 2U2 25V CASE B	CS5228R-CASBK
CA4	SM TANT CAP 2U2 25V CASE B	CS5228R-CASBK
DA1-12	BAV70 SM DUAL DIODE COM CATH	BS0013R-SOT23
DA16	BAV99 SM DIODE	BS0005R-SOT23
DA17	BAV99 SM DIODE	BS0005R-SOT23
DZ1	ZENER DIODE 300MW 5V1 BZX84C	BS0020R-SOT23
IC1	LM2901 SM QUAD COMARATOR	BS7007R-SO14
IC2	LM2901 SM QUAD COMARATOR	BS7007R-SO14
IC3	LM2901 SM QUAD COMARATOR	BS7007R-SO14
IC4	LM2901 SM QUAD COMARATOR	BS7007R-SO14
IC5	LM2901 SM QUAD COMARATOR	BS7007R-SO14
IC6	LM2901 SM QUAD COMARATOR	BS7007R-SO14
IC7	TL072CD SM DUAL OP AMP	BS7001R-SO8
IC8	TL072CD SM DUAL OP AMP	BS7001R-SO8
IC9	TL072CD SM DUAL OP AMP	BS7001R-SO8
IC10	TL072CD SM DUAL OP AMP	BS7001R-SO8
IC11	TL072CD SM DUAL OP AMP	BS7001R-SO8
IC12	TL072CD SM DUAL OP AMP	BS7001R-SO8
IC13	TL072CD SM DUAL OP AMP	BS7001R-SO8
IC14	TL072CD SM DUAL OP AMP	BS7001R-SO8
IC15	4051 CMOS 8 TO 1 MULTIPLEXER	BS1107R-SO16
IC16	4051 CMOS 8 TO 1 MULTIPLEXER	BS1107R-SO16
IC17	4051 CMOS 8 TO 1 MULTIPLEXER	BS1107R-SO16
IC18	HEF4518BT-T3 CMOS COUNTER	BS1112R-SO16
IC19	CD4011BCMX INPUT NAND	BS1111R-SO14
Q1	NPN TRANS BCW72	BS0502R-SOT23
QA1	PNP TRANS BCW70	BS0501R-SOT23
QA2	PNP TRANS BCW70	BS0501R-SOT23
QA3-28	NPN TRANS BCW72	BS0502R-SOT23
R1	SM0805 RES 1K 1% 0.1W T200	AS0102R-0805F
R2	SM0805 RES 560R 1% 0.1W T200	AS0561R-0805F
R3	SM0805 RES 1K 1% 0.1W T200	AS0102R-0805F
R4	SM0805 RES 1K 1% 0.1W T200	AS0102R-0805F
R5	SM0805 RES 1K5 1% 0.1W T200	AS0152R-0805F
R6	SM0805 RES 2K 1% 0.1W T200	AS0202R-0805F
R7	SM0805 RES 3K0 1% 0.1W T200	AS0302R-0805F
R8	SM0805 RES 3K9 1% 0.1W T200	AS0392R-0805F
R9	SM0805 RES 6K2 1% 0.1W T200	AS0622R-0805F
R10	SM0805 RES 8K2 1% 0.1W T200	AS0822R-0805F
R11	SM0805 RES 12K 1% 0.1W T200	AS0123R-0805F
R12	SM0805 RES 24K 1% 0.1W T200	AS0243R-0805F
R13	SM0805 RES 18K 1% 0.1W T200	AS0183R-0805F
R14	SM0805 RES 2K2 1% 0.1W T200	AS0222R-0805F
R15	SM0805 RES 470R 1% 0.1W T200	AS0471R-0805F
R16	SM0805 RES 470R 1% 0.1W T200	AS0471R-0805F
R17	SM0805 RES 470R 1% 0.1W T200	AS0471R-0805F
R18	SM0805 RES 470R 1% 0.1W T200	AS0471R-0805F
R19	SM0805 RES 2K2 1% 0.1W T200	AS0222R-0805F
R20	SM0805 RES 100K 1% 0.1W T200	AS0104R-0805F
R21	SM0805 RES 1K 1% 0.1W T200	AS0102R-0805F
R22	SM0805 RES 560R 1% 0.1W T200	AS0561R-0805F
R23	SM0805 RES 1K 1% 0.1W T200	AS0102R-0805F
R24	SM0805 RES 1K 1% 0.1W T200	AS0102R-0805F
R25	SM0805 RES 1K5 1% 0.1W T200	AS0152R-0805F
R25	SM0805 RES 22K 1% 0.1W T200	AS0223R-0805F
R26	SM0805 RES 2K 1% 0.1W T200	AS0202R-0805F
R27	SM0805 RES 3K0 1% 0.1W T200	AS0302R-0805F
R28	SM0805 RES 3K9 1% 0.1W T200	AS0392R-0805F
R29	SM0805 RES 6K2 1% 0.1W T200	AS0622R-0805F
R30	SM0805 RES 8K2 1% 0.1W T200	AS0822R-0805F
R31	SM0805 RES 12K 1% 0.1W T200	AS0123R-0805F
R32	SM0805 RES 24K 1% 0.1W T200	AS0243R-0805F
R33	SM0805 RES 18K 1% 0.1W T200	AS0183R-0805F
R34	SM0805 RES 2K2 1% 0.1W T200	AS0222R-0805F
R35	SM0805 RES 100K 1% 0.1W T200	AS0104R-0805F
R36	SM0805 RES 47K 1% 0.1W T200	AS0473R-0805F
R37	SM0805 RES 100K 1% 0.1W T200	AS0104R-0805F
R38	SM0805 RES 47K 1% 0.1W T200	AS0473R-0805F

---

R39	SM0805 RES 47K 1% 0.1W T200	AS0473R-0805F
R40	SM0805 RES 47K 1% 0.1W T200	AS0473R-0805F
R41	SM0805 RES 47K 1% 0.1W T200	AS0473R-0805F
R42	SM0805 RES 47K 1% 0.1W T200	AS0473R-0805F
R43	SM0805 RES 47K 1% 0.1W T200	AS0473R-0805F
R44	SM0805 RES 47K 1% 0.1W T200	AS0473R-0805F
R45	SM0805 RES 47K 1% 0.1W T200	AS0473R-0805F
R46	SM0805 RES 47K 1% 0.1W T200	AS0473R-0805F
R47	SM0805 RES 47K 1% 0.1W T200	AS0473R-0805F
R48	SM0805 RES 47K 1% 0.1W T200	AS0473R-0805F
R49	SM0805 RES 47K 1% 0.1W T200	AS0473R-0805F
R50	SM0805 RES 47K 1% 0.1W T200	AS0473R-0805F
R51	SM0805 RES 47K 1% 0.1W T200	AS0473R-0805F
R52	SM0805 RES 47K 1% 0.1W T200	AS0473R-0805F
R53	SM0805 RES 47K 1% 0.1W T200	AS0473R-0805F
R54	SM0805 RES 47K 1% 0.1W T200	AS0473R-0805F
R55	SM0805 RES 47K 1% 0.1W T200	AS0473R-0805F
R56	SM0805 RES 47K 1% 0.1W T200	AS0473R-0805F
R57	SM0805 RES 47K 1% 0.1W T200	AS0473R-0805F
R58	SM0805 RES 47K 1% 0.1W T200	AS0473R-0805F
R59	SM0805 RES 47K 1% 0.1W T200	AS0473R-0805F
R60	SM0805 RES 47K 1% 0.1W T200	AS0473R-0805F
R61	SM0805 RES 47K 1% 0.1W T200	AS0473R-0805F
R62	SM0805 RES 47R 1% 0.1W T200	AS0470R-0805F
R63	SM0805 RES 47R 1% 0.1W T200	AS0470R-0805F
RA1	SM0805 RES 10K 1% 0.1W T200	AS0103R-0805F
RA2	SM0805 RES 10K 1% 0.1W T200	AS0103R-0805F
RA3	SM0805 RES 22K 1% 0.1W T200	AS0223R-0805F
RA4	SM0805 RES 22K 1% 0.1W T200	AS0223R-0805F
RA5	SM0805 RES 100K 1% 0.1W T200	AS0104R-0805F
RA6	SM0805 RES 100K 1% 0.1W T200	AS0104R-0805F
RA7	SM0805 RES 100R 1% 0.1W T200	AS0101R-0805F
RA8	SM0805 RES 100R 1% 0.1W T200	AS0101R-0805F
RA9	SM0805 RES 22K 1% 0.1W T200	AS0223R-0805F
RA10	SM0805 RES 22K 1% 0.1W T200	AS0223R-0805F
RA23	SM0805 RES 56K 1% 0.1W T200	AS0563R-0805F
RA24	SM0805 RES 56K 1% 0.1W T200	AS0563R-0805F
RA26	SM0805 RES 22K 1% 0.1W T200	AS0223R-0805F
RA27	SM0805 RES 100K 1% 0.1W T200	AS0104R-0805F
RA28	SM0805 RES 100K 1% 0.1W T200	AS0104R-0805F
RA29	SM0805 RES 470R 1% 0.1W T200	AS0471R-0805F
RA30	SM0805 RES 470R 1% 0.1W T200	AS0471R-0805F
RA31	SM0805 RES 2K2 1% 0.1W T200	AS0222R-0805F
RA32	SM0805 RES 2K2 1% 0.1W T200	AS0222R-0805F
RC23	SM0805 RES 100K 1% 0.1W T200	AS0104R-0805F
RC24	SM0805 RES 100K 1% 0.1W T200	AS0104R-0805F
RG23	SM0805 RES 39K 1% 0.1W T200	AS0393R-0805F
RG24	SM0805 RES 39K 1% 0.1W T200	AS0393R-0805F

## MISCELLANEOUS HARDWARE

Description	Part Number	Used in: (part number)
10WY 0.75MM GREY PVC NO.CODED	LD0317	RV3487
2BA VIBRATION RESIST.SOLDR TAG	NE0409	RV3487
FOAM STRIP S/ADH 12mm	ZZ2914	RV3486, RW8006
HC49U CRYSTAL MYLAR INSULATOR	ZZ2892	RC4023
HEYCO STRAIN RELIEF BUSH 1244	ZZ2888	RW8006
M2.5X6 PAN POZI SCREW BLK	NA0429	RW5595
M3 NYLON INSERT NUT	NB0113	RW5594
M3 S/PROOF WASHER	NC0221	RW5594
M3 X 8MM PAN POZI BLCK SCRW	NA0130	RD4025
M3X10MM PAN POZI SCR BLK	NA0394	RW5594
M3X20MM TAPPED PILLAR	ND0321	RW5594
M3X5 CSK POZI BLK TRUNCATED SC	NA0328	RW5594
M3X6 PAN POZI STAINLESS+WASHER	NA0428	RE4019, RF4020
M3X6 PN PZI W/CAPT WASHER ZNC	NA0401	RW5594
M3X6MM PAN POZI BLK SCREW	NA0084	RW5594
M3X8MM CSK POZI SCREW BLACK	NA0210	RW5594
M4 BARB NUT	NB0168	RW5596
M4 FULL NUT	NB0154	RW5594
M4 S/PROOF WASHER	NC0248	RW5594
M4X10MM MUSHROOM HD PN PZ BLK	NA0291	RW5594
M4X10MM PAN POZI STL SCR BLACK	NA0146	RW5594
M4X8MM CSK POZI ZINC	NA0296	RW5594
M4X8MM PAN POZI SCRW BLCK	NA0241	RW5594
M4X9.53 TAPPED SPACER NYLON HE	ND0400	RW5594
M5 NYLON INSERT NUT	NB0116	RV3486
M5X70MM HEX BOLT BLACK	NA0410	RV3486
M5X8MM PAN HEAD SCR ZINC	NA0277	RW5595
M8X45MM CSK SKT SCRW BLCK	NA0227	RW5594
NO10-14X1/2" PAN POZI PLASTITE	NA0346	RW5596
NO4X3/8" PAN POZI S/T BLK SCRW	NA0249	RW5594
NUT(PART OF FH0773&FH0786)	NB0176	RW5594
PILLAR M3F/M2 5FX14.80MM BRASS	ND0433	RE4019, RF4020
RICHO SCREW ON PLASTIC FEET	ZZ2541	RW8006
VIB RES CRIMP TAG V5 TIN PLT	NE0416	RV3490, RV4071
WASHER(PART OF FH0773&FH0786)	NC0296	RW5594

