

Engineering Data Book

for

Stromberg-Carlson

Nos. 19 and 20 Superheterodyne

Radio Receivers

FOR A. C. OPERATION

STROMBERG-CARLSON TELEPHONE MANUFACTURING COMPANY
Kansas City, Missouri Rochester, New York Chicago, Illinois
United States of America

**STROMBERG-CARLSON TELEPHONE MANUFACTURING COMPANY
OF CANADA LTD.**
Toronto, Ontario, Dominion of Canada

STROMBERG-CARLSON (AUSTRALASIA) LIMITED
Sydney, New South Wales, Australia

ENGINEERING DATA
STROMBERG-CARLSON NOS. 19 AND 20 RECEIVERS

ELECTRICAL SPECIFICATIONS

TYPE OF CIRCUIT	-----			SUPERHETERODYNE	
TYPE AND NUMBER OF TUBES	-----			4 No. 35, 2 No. 27, 2 No. 45, 1 No. 80	
VOLTAGE RATING	-----			105-125 VOLTS.	
FREQUENCY RATING	-----			60 CYCLE AND 25-60 CYCLE	
POWER CONSUMPTION	-----			135 WATTS	
INTERMEDIATE FREQUENCY	-----			175 K.C.	

CIRCUIT DESCRIPTION

FOUR NO. 35 TUBES ARE USED AS R.F. AMPLIFIER, MIXER AND I.F. AMPLIFIER; TWO NO. 27 TUBES ARE USED AS OSCILLATOR AND DEMODULATOR; TWO NO. 45 TUBES ARE USED IN THE PUSH PULL OUTPUT STAGE; A NO. 80 RECTIFIER IS USED IN THE POWER SUPPLY.

A BI-RESONATOR IS USED TO COUPLE THE ANTENNA TO THE R.F. AMPLIFIER TO PREVENT ANY CROSS MODULATION. THE R.F. AMPLIFIER IS COUPLED TO THE MIXER BY AN ORDINARY TUNED R.F. TRANSFORMER. THIS GIVES THREE TUNING CIRCUITS (FOUR GANG TUNING CAPACITOR). THE OSCILLATOR IS COUPLED TO THE CATHODE CIRCUIT OF THE MIXER TUBE IN THE REGULAR MANNER. THE INTERMEDIATE AMPLIFIER IS COMPOSED OF TWO STAGES WITH TRANSFORMERS TUNED TO 175 K.C. THE SIGNAL FROM THE OUTPUT OF THE MIXER IS COUPLED TO THE CONTROL GRID OF THE FIRST I.F. AMPLIFIER BY THE FIRST I.F. TRANSFORMER. THE PRIMARY AND SECONDARY OF THIS TRANSFORMER ARE BOTH TUNED BY ALIGNING CAPACITORS. THE OUTPUT OF THE SECOND I.F. TUBE IS FED TO THE DETECTOR BY MEANS OF THE THIRD I.F. TRANSFORMER. THIS TRANSFORMER HAS AN UNTUNED PRIMARY AND TUNED SECONDARY.

THE AUDIO OUTPUT IS FED THROUGH A RADIO FREQUENCY FILTER TO THE RESISTOR UNIT OF THE MANUAL VOLUME CONTROL WHICH ACTS AS A COUPLING RESISTOR TO THE AUDIO AMPLIFIER. ADJUSTABLE AUTOMATIC CLARIFIER CIRCUIT IS CONNECTED ACROSS THE PLATES OF THESE PUSH PULL TUBES. THE OUTPUT TRANSFORMER FEEDS THE SIGNAL TO THE HIGH QUALITY ELECTRO DYNAMIC SPEAKER.

THE POWER SUPPLY SYSTEM EMPLOYS TWO STAGES OF FILTER, THE CHOKE OF THE SECONDARY BEING THE FIELD WINDING OF THE SPEAKER. THE PLATE SUPPLY FOR THE OUTPUT TUBES, AND THE DETECTOR AMPLIFIER IS TAPPED OFF BETWEEN THESE FILTER STAGES, WHILE THE REMAINDER OF THE VOLTAGES ARE TAKEN FROM THE VOLTAGE DIVIDER RESISTORS.

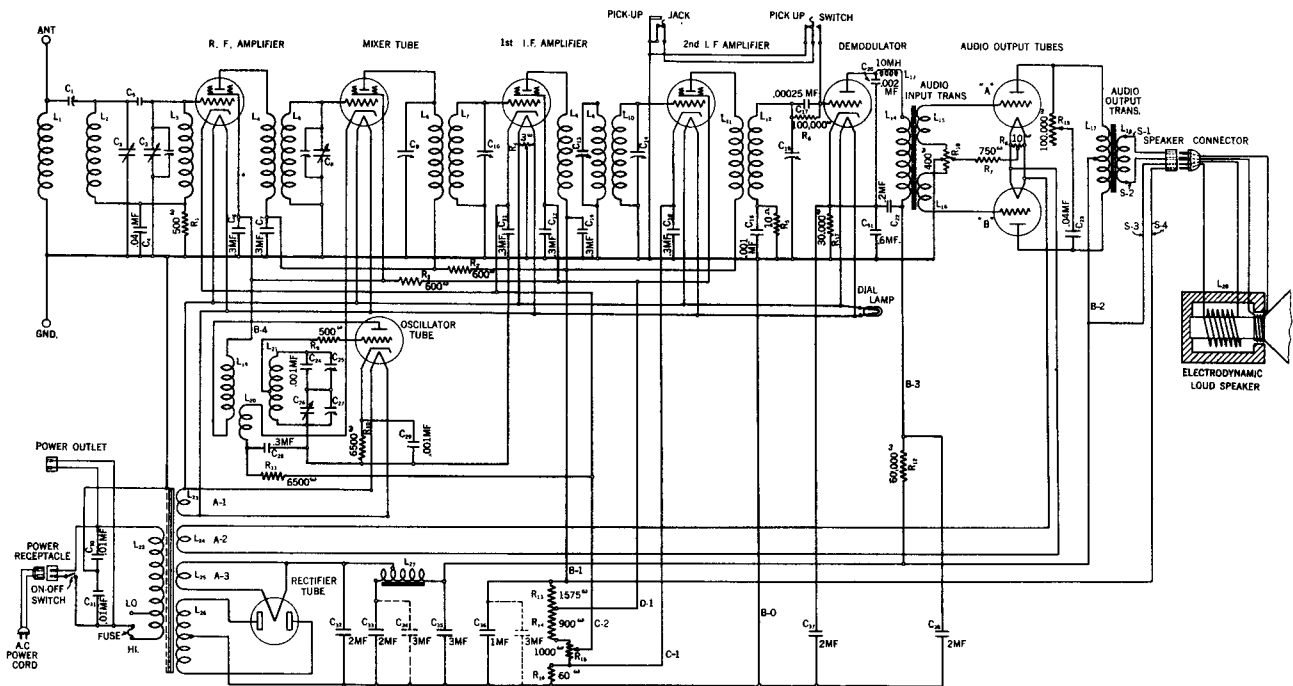
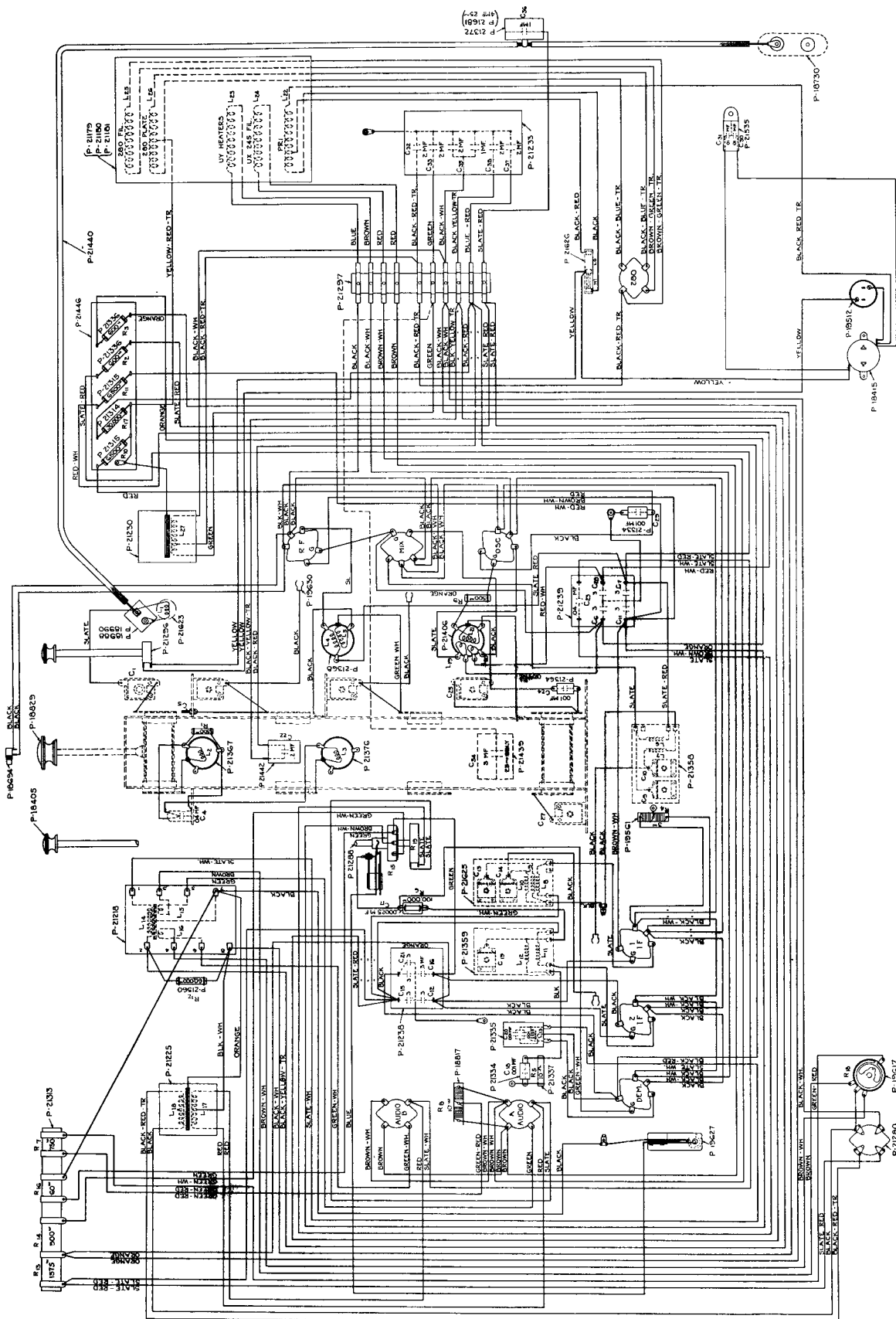

FIG. 1. SCHEMATIC CIRCUIT OF NOS. 19 & 20 RECEIVERS.

NORMAL VOLTAGE READINGS

THESE VOLTAGE READINGS CORRESPOND TO A LINE VOLTAGE AT 120 VOLTS WITH THE HI-LO FUSE IN HI OR AT 110 VOLTS WITH FUSE IN LO. WHEN VOLTAGES ARE MEASURED, PROPER ALLOWANCES SHOULD BE MADE FOR A DIFFERENCE IN LINE VOLTAGE ABOVE OR BELOW 110 OR 120 VOLTS. BE SURE TO MAKE THESE READINGS WITH THE METER AND SCALE INDICATED, OTHERWISE THE RESULTS WILL NOT AGREE WITH THOSE TABULATED. ALTERNATING VOLTAGES ARE INDICATED IN ITALICS. THE DIAL SHOULD BE SET AT ABOUT 1000 KC.



Normal Voltage Readings

(Be sure to make these readings with the Meter and Scale indicated, otherwise the results will not agree with those tabulated. Alternating voltages are indicated by italics)

Voltage	Meter	Scale	Where Measured	Approx. Value in Volts
Heater Voltage Nos. 227 & 235 Tubes	A.C.	0-4	Across Heater Terminals of Sockets	2.4
Filament Voltage No. 245 Tubes	A.C.	0-4	Across Filament Terminals of Audio Output Sockets	2.4
Filament Voltage No. 280 Tube	A.C.	0-8	Across Filament Terminals of Rectifier Socket	4.8
Plate Voltage Radio Amplifiers	D.C.	0-250	Between Plate Terminal of R. F. Amplifier Socket (+) and Chassis Base (-)	150-170
Plate Voltage Mixer Tube	D.C.	0-250	Between Plate Terminal Mixer Tube Socket (+) and Chassis Base (-)	150-170
Plate Voltage Oscillator	D.C.	0-250	Between Plate Terminal of Oscillator Socket (+) and Chassis Base (-)	85-90
Plate Voltage I.F. Tubes	D.C.	0-250	Between Plate Terminals of I. F. Amplifier Sockets (+) and Chassis Base (-)	150-170
Plate Voltage Demodulator	D.C.	0-250	Between Plate Terminal of Demodulator Socket (+) and Chassis Base (-)	190-215
Plate Voltage Audio Output Tubes	D.C.	0-250	Between Plate Terminals Audio Output Socket (+) and 10 ohm Mid Tap Resistor R_8 (-)	250
Control Grid Voltage R.F. Amplifier	D.C.	0-10	Between Control Grid Clip of R. F. Amplifier Tube (-) and Cathode (+) of R. F. Amplifier Tube	3
Control Grid Voltage Mixer Tube	D.C.	0-250	Between Control Grid Clip Mixer Tube (-) and Cathode (+) of Mixer Tube	10-12
Control Grid Voltage 1st I.F. Amplifier	D.C.	0-10	Between Control Grid Clip 1st I. F. Tube (-) to Cathode (+) of 1st I. F. Tube	3
Control Grid Voltage 2nd I.F. Tube	D.C.	0-10	Between Control Grid Clip 2nd I. F. Tube (-) to Cathode (+) of 2nd I. F. Tube	3
Grid Voltage Oscillator	D.C.	0-250	Across 6500 ohm Resistor R_{10}	10-15
Grid Voltage Demodulator	D.C.	0-250	Across 30,000 ohm Resistor R_{17}	20-25
Grid Voltage Audio Tubes	D.C.	0-250	Between Grids of Audio Tubes (-) to Mid Tap 10 ohm Resistor R_8 (+)	45-50*
Screen Voltage Radio Amplifier Mixer 1st & 2nd I.F. Tubes	D.C.	0-250	Between Screen Terminals of Tubes (+) to Chassis Base (-)	80-90*

Voltage	Meter	Scale	Where Measured	Approx. Value in Volts
B Voltage R.F. Amplifier and Mixer Tube	D.C.	0-250	Between Tube Side of 600 ohm Resistor R ₂ (+) and Chassis Base (-)	150-170*
B Voltage 1st & 2nd I.F. and Mixer Tubes	D.C.	0-250	Between "High" Side of Voltage Divider (+) and Chassis Base (-)	150-170*
B Voltage Audic Tubes	D.C.	0-250	Between Mid Tap of Audio Output Transformer (+) and Chassis Base (-)	300
C Voltage Audio Output Tubes	D.C.	0-250	Across 750 ohm Biasing Resistor R ₇	50
Speaker Field Voltage	D.C.	0-250	Across Small Pins of Speaker Connector Socket	150-170
Plate Voltage A.C. Pere Anode No. 280 Rectifier	A.C.	See Remarks	Between P Terminals No. 280 Rectifier Socket and Chassis Base	325-350†

*These voltage vary with dial setting and position of volume control.

†Cannot be measured on Weston Model 528 Meter unless multiplier is used.

REPLACEMENT PARTS.

<i>Piece Number</i>	<i>Name of Part</i>	<i>Description</i>	<i>Required per Receiver</i>
P-21218	Audio Input Transformer .	Push-Pull Input Transformer	1
P-21225	Audio Output Transformer .	Push-Pull Output Transformer	1
P-18730	Binding Post Assembly . .	Antenna and Ground Binding Posts	1
P-18937	Cap	Aligning Capacitor Covers .	10
P-21270	Capacitor, Aligning . . .	Aligning Capacitor on Variable	1
P-21262	Capacitor, Aligning . . .	Aligning Capacitor on Variable (C ₂₅)	1
P-21358	Coil and Capacitor Assembly {	First I. F. Transformer . .	1
P-21625	Coil and Capacitor Assembly }	Second I. F. Transformer .	1
P-21359	Coil and Capacitor Assembly {	Third I. F. Transformer . .	1
P-21364	Capacitor	Series Capacitor Oscillator Tuning (C ₂₄)	1
P-19452	Capacitor	Main Bi-resonator Coupling Capacitor .04 Mf. (C ₄) .	1

<i>Number Piece</i>	<i>Name of Part</i>	<i>Description</i>	<i>Required Receiver per</i>
P-21238	Capacitor	By-pass Capacitor Assembly (C ₁₂ , C ₁₅ , C ₁₆ , C ₂₁)	1
P-21239	Capacitor	By-pass Capacitor Assembly (C ₆ , C ₇ , C ₁₁ , C ₂₃ , C ₂₈)	1
P-21372	Capacitor	By-pass Capacitor 1 Mf. (C ₃₆)	1
P-21442	Capacitor	Hum Balancing Capacitor .2 Mf. (C ₂₂)	1
P-21334	Capacitor	Fixed Capacitor .001 Mf. (C ₂₉)	2
P-21233	Capacitor	Filter Capacitor Assembly (C ₃₂ , C ₃₃ , C ₃₅ , C ₃₇ , C ₃₈)	1
P-21439	Capacitor	Extra Filter Capacitor for 25 Cycles 3 Mf. (C ₃₄)	1
P-21535	Capacitor	Line Filter across A. C. Input (C ₃₀ and C ₃₁)	1
P-21367	Coil Assembly	First Coil of Bi-resonator (L ₂)	1
P-21623	Coil Assembly	Antenna Inductor (L ₁)	1
P-21376	Coil Assembly	Second Coil of Bi-resonator (L ₃)	1
P-21368	Coil Assembly	Radio Transformer (L ₄ and L ₅)	1
P-21406	Coil Assembly	Oscillator Tuning Inductors (L ₁₉ , L ₂₀ , L ₂₁)	1
P-18746	Cone and Moving Coil As- sembly	Moving Element of P-21347 10" Dynamic Speaker	1
P-19512	Connector, Supply Cord	Input Power Supply Recep- tacle	1
P-19502	Cord	Power Supply Cord to Chassis	1
P-19415	Cord	Speaker Connector Cord	1
P-21360	Dial	Station Selector Dial	1
P-21343	Drive Assembly	Driving Shaft for Gang Tun- ing Capacitor	1
P-21357	Escutcheon Assembly	Dial Escutcheon	1
P-21335	Filter Assembly	Demodulator Plate Filter	1
P-19627	Frame and Spring Assembly	Pick-up Jack	1
P-21566	Fuse	1½ Amperes	1
P-19630	Grid Clip	Control Grid Clip for Tet- rodes	1
P-21230	Inductor Assembly	"B" Filter Inductor (L ₂₇)	1
P-18429	Knob—Large	Station Selector Knob	1
P-18405	Knob—Small	Volume Control and On-Off Switch Knobs	2

<i>Number Piece</i>	<i>Name of Part</i>	<i>Description</i>	<i>Receiver per Required</i>
P-18415	Receptacle, Convenience Outlet	Power Supply Output (Rear of Chassis)	1
P-19617	Potentiometer (Wire Wound)	Hum Adjuster (R ₁₃)	1
P-19561	Resistor, 3 ohms	Resistor Across Heater of First I. F. Socket (R ₄)	1
P-18817	Resistor, 10 ohms	Resistor Across Filaments of Output Socket (R ₈)	1
P-19023	Resistor, 500 ohms	Carbon Resistor, Green-Black-Brown (R ₁ , R ₂ , R ₉)	2
P-21336	Resistor, 600 ohms	Carbon Resistor, Blue-Black-Brown	2
P-21315	Resistor, 6,500 ohms	Carbon Resistor, Blue-Green-Red	1
P-21314	Resistor, 30,000 ohms	Carbon Resistor, Orange-Black-Orange	1
P-21560	Resistor, 60,000 ohms	Carbon Resistor, Blue-Black-Orange	1
P-18945	Resistor, 100,000 ohms	Carbon Resistor, Brown-Black-Green	1
P-21337	Resistor, 10 Megohms	Carbon Resistor, Brown-Black-Blue	1
P-21313	Resistor, 3,285 ohms	Voltage Divider, Vitreous Enameled	1
P-21280	Socket	UX Type (4-Prong)	4
P-21278	Socket	UY Type (5-Prong)	6
P-21347	Speaker	Complete Assembly 10" Cone	1
P-21296	Switch	On-Off	
P-21181	Transformer	Power, 25-60 Cycle, 110 Volts	1
P-21179	Transformer	Power, 60 Cycle, 110 Volts	1
P-21472	Transformer	Step-Down Transformer for use on 220-Volt Lines	1
P-21288	Volume Control and Automatic Clarifier Assembly	1

Schematic Circuit of Chassis for Nos. 19 a

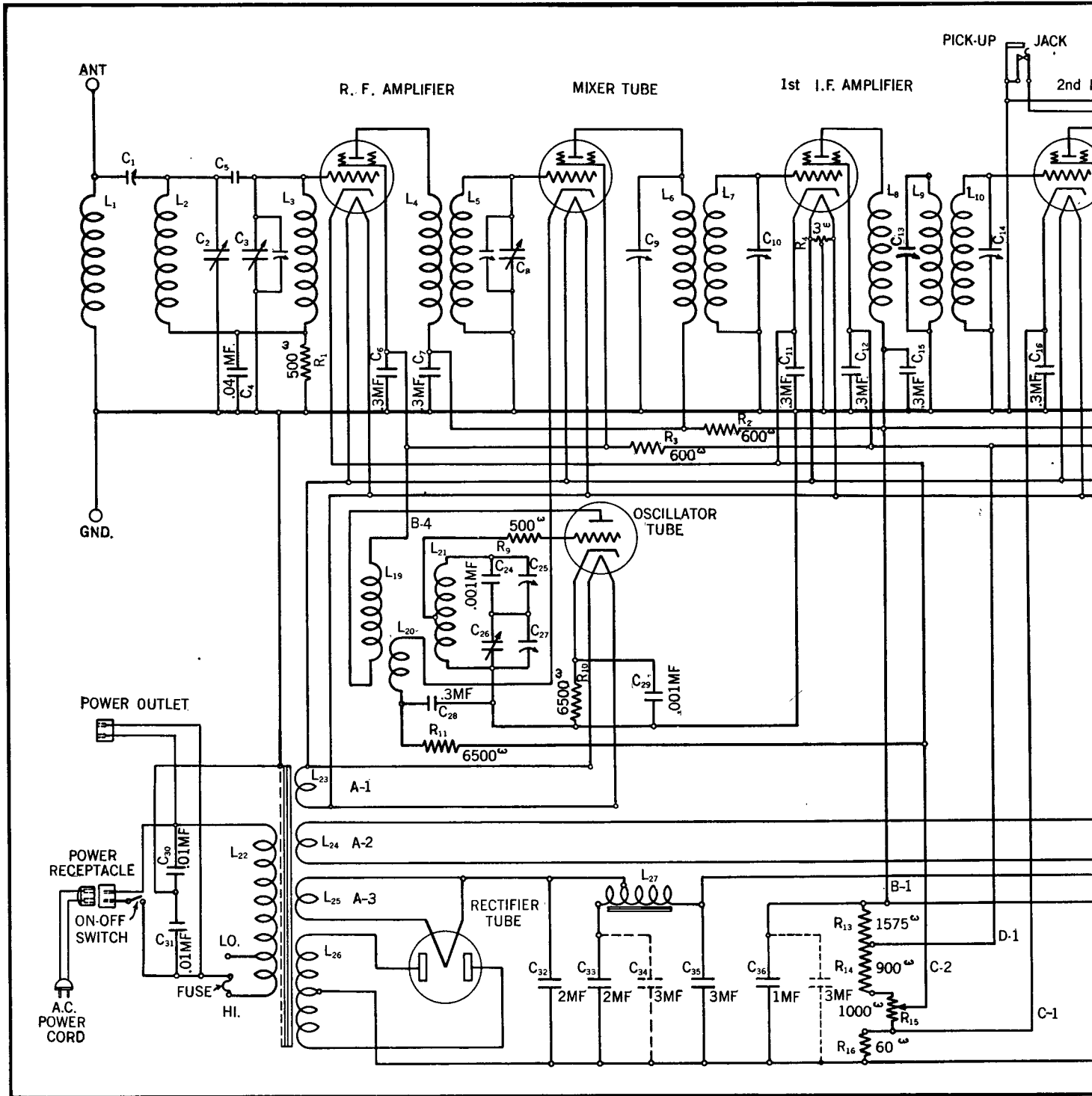

19 and 20 Superheterodyne Receivers

