

Engineering Data

Stromberg-Carlson Nos. 335 and 336 Radio Receivers

STROMBERG-CARLSON TELEPHONE MANUFACTURING COMPANY
ROCHESTER, NEW YORK

ELECTRICAL SPECIFICATIONS

Type of Circuit	-----	Superheterodyne with Electric Tuning
Tuning Ranges	-----	Range "A", 530 to 1700 Kc.; Range "C", 5900 to 18,000 Kc.
Number and Type of Tubes	-----	1 No. 6A8; 1 No. 6K7; 1 No. 6H6; 1 No. 6F5; 1 No. 6F6G; 1 No. 6U5; 1 No. 80
Power Supply Voltage	-----	105 to 125 Volts, A. C.
Power Frequency Rating	-----	50 to 60 Cycles and 25 to 60 Cycles
Input Power Rating:		
Radio Models Only	-----	65 Watts
Radio-Phono. Models	-----	80 Watts
Frequency of Intermediate Amplifier	-----	455 Kilocycles

APPARATUS SPECIFICATIONS

No. 335-L Receiver	-----	50 to 60 Cycles; P-28818 Chassis Assembly; P-27605 Loud Speaker
No. 335-LB Receiver	-----	25 to 60 Cycles; P-28819 Chassis Assembly; P-27605 Loud Speaker
No. 336-P Receiver	-----	60 Cycles Only; P-29415 Chassis; P-29439 Phono Unit; P-29464 Loud Speaker
No. 336-PB Receiver	-----	25 Cycles Only; P-29416 Chassis; P-29440 Phono Unit; P-29464 Loud Speaker

CIRCUIT DESCRIPTION

These receivers are seven tube, instantaneous "Electric Tuning", superheterodyne receivers employing metal tubes and a highly efficient dynamic speaker. There are two tuning ranges, the frequency limits of each range being listed under the "Electrical Specifications", given above.

The electric tuning circuit is arranged so that six favorite stations located in the Standard Broadcast range may be set up for instantaneous selection by means of the push buttons. (Local and other stations that give the best daytime and evening service should be selected.) To properly set up the electric tuning arrangement for the six favorite Standard Broadcast stations, read the section, "Instructions for Setting Up the Electric Tuning Arrangement", appearing on page 4 of this book. Manual or electric tuning for the Standard Broadcast range is easily obtainable by simply rotating the Range Switch control knob so that the arrow on the knob points in the direction of the designation for the desired type of tuning. When manually tuning the receiver in either the Standard Broadcast or Short Wave ranges, the electric tuning arrangement is made inoperative and the dial of the receiver is illuminated. When the Range Switch control knob is set for electric tuning (arrow on Range Switch control knob pointing in direction of the star), the dial illumination ceases and the station letters of the six stations which are set up for electric tuning become illuminated. When manually tuning these receivers or when setting up the six desired stations for electric tuning, resonance with a signal is indicated by means of the tuning indicator tube which operates on the cathode-ray principle.

A special temperature controlled compensating capacitor is used in the oscillator circuit of these receivers when operating the electric tuning arrangement in order to eliminate drift in the oscillator's frequency. These

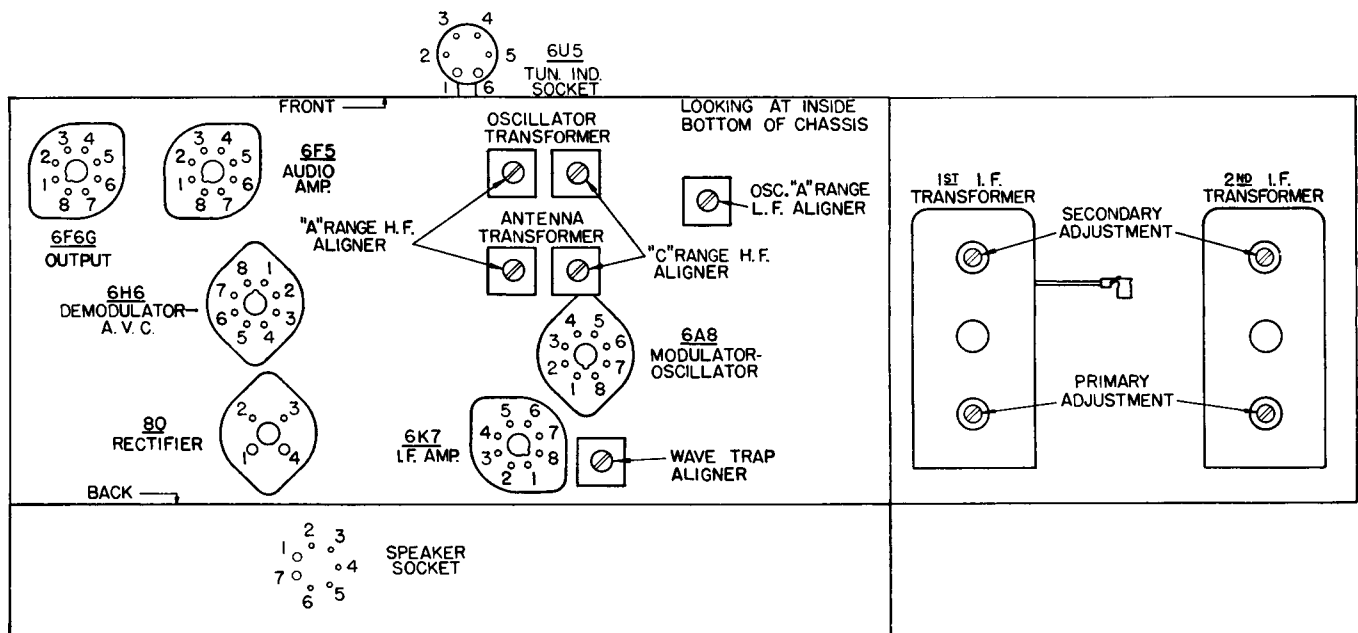

Fig. 1. Terminal Layout for Voltage Measurement Chart and Location of the Aligning Capacitors.

receivers are also provided with a low level bass frequency compensating circuit in conjunction with the volume control circuit so that balanced reproduction is obtained for any setting of the volume control.

In addition to the above features the No. 336-P Receiver is also equipped with a constant speed, single record playing phonograph unit which uses a crystal type pick-up in conjunction with a specially equalized circuit.

The chassis used in the No. 336 Receivers differ from the chassis used in the No. 335 Receivers only in the type of electrolytic filter capacitors which are used and the addition of the "Radio-Phono" control switch.

The various tubes are used in these receivers as follows: The No. 6A8 tube functions as both the Modulator and Oscillator tube. The No. 6K7 tube is used in the I. F. Amplifier and the No. 6H6 tube is used as both the Demodulator and automatic Volume Control tube. The No. 6F5 tube is used in the Audio Amplifier and the No. 6F6G tube is used in the Audio Power Output Stage. The No. 6U5 tube is used for indicating resonance in the tuning indicator system and the No. 80 tube is the Rectifier tube of the Power Supply Unit.

NORMAL VOLTAGE READINGS

The values of voltages listed in the following table are obtained by measuring between the various tube socket contacts and the chassis base, with the tubes in their respective sockets. The receiver is, therefore, in full operation when the measurements are made. Figure 1, shows the terminal layout of the sockets with the proper terminal numbers.

Voltages are given for a line voltage of 120 volts, and allowance should be made for differences when the line voltage is higher or lower. A meter having a resistance of 1000 ohms per volt should be used for measuring the D. C. voltages. Voltage values shown are those obtained on the lowest possible scale of a meter having the following ranges: 0-2.5, 0-10, 0-100, 0-250, 0-500, 0-1000 volts except when an asterisk appears after any given voltage value in which case the 250 volt scale was used.

Tube	Circuit	Cap	Terminals of Sockets								Heater Voltages Between Heater Terminals	
			1	2	3	4	5	6	7	8	Socket Terminal Numbers	Volts
6A8	Mod., Osc.	0	0	0	+245	+68	-10	+235	6.2	+2.8	2-7	6.2
6K7	I. F. Amp.	0	0	0	+250	+78	+2.8	+280	6.2	+2.8	2-7	6.2
6H6	Dem., A. V. C.	—	0	0	0	0	0	0	6.2	0	2-7	6.2
6F5	Audio Amp.	0	0	0	+250	+56	0	0	6.2	0	2-7	6.2
6F6G	Audio Output	—	0	0	+235	+250	0	0	6.2	+14.5	2-7	6.2
6U5	Tuning Ind.	—	6.2	+18*	-1.5	+250	0	0	—	—	1-6	6.2
80	Rectifier	—	+360	350	350	+360	*—	—	—	—	1-4	5.0
Speaker Socket			+360	0	0	+360	+360	0	+250	—		

Receiver tuned manually to 1000 Kc., no signal. A. C. voltages are indicated by italics.

ALIGNMENT DATA

All alignment adjustments are accurately made at the factory on these receivers, and ordinarily no readjustments are necessary. However, should it become necessary to make any readjustments, the alignment procedure given in the following paragraphs should be carefully followed. In order to make these aligning adjustments in an easy and satisfactory manner, it is recommended that the Stromberg-Carlson P-27657 and P-27658 aligning tools be used.

To accurately align the circuits in these receivers, it is necessary to use a high grade, modulated test oscillator (Signal Generator), the output voltage of which can be varied. In conjunction with this test oscillator, a sensitive output meter should be used for determining the maximum signal voltage developed across the voice coil of the loud speaker.

In making any alignment adjustments, always adjust the test oscillator's output voltage to the minimum value where a good alignment may still be obtained. Never attempt to make any alignment adjustments using a strong signal. Before proceeding with the alignment of any circuits in these receivers be sure that the "Off-On-Tone" control knob is set for maximum treble response (position where knob is rotated from its maximum counter-clockwise position, slightly clockwise to position where set turns "on"), and that the electric tuning switch, located on the rear of the chassis base is rotated to the "Set-Up" position. When the aligning adjustments have been completed the electric tuning switch should be rotated back to the "Operate" position. Figure 1, shows the location of all the aligning capacitors in these receivers.

In making any alignment adjustments on the No. 335 receivers, it will not be necessary to remove the chassis from the cabinet. The aligning capacitors for the intermediate frequency circuits of these receivers are easily accessible from the rear of the receiver, and the aligning capacitors for the radio frequency circuits are easily accessible either through the bottom of the cabinet or through the bottom of the cabinet shelf depending upon the style of cabinet.

In making any aligning adjustments of the radio frequency circuits of the No. 336-P Receiver, it will be necessary to remove the chassis from the cabinet. The aligning adjustments for the intermediate frequency circuits of these receivers are easily accessible through the bottom of the cabinet.

Dial Adjustment

Before aligning the circuits of any of these receivers, the tuning dial must be properly aligned to track with the gang tuning capacitors. To check whether the dial is set correctly with respect to the gang tuning capacitor, rotate the "Station Selector" knob in a clockwise direction so that the gang tuning capacitor is set to its maximum capacity position. Then, with the gang tuning capacitor in this position, the dial pointer should be placed on the horizontal center line of the dial. To do this, align the pointer with the short black line located at the extreme right-hand edge of the dial plate.

Intermediate Frequency Adjustments

The intermediate frequency used in these receivers is 455 kilocycles. In making these circuit adjustments always align the circuits in the order given in these instructions.

1. Set the Electric Tuning and Range Switch control knob to the manual tuning standard broadcast position (arrow on knob pointing in direction of letters "BR."). Set the dial pointer by means of the Station Selector knobs to the extreme low frequency position on the receiver's dial. Rotate the "Off-On-Tone" control knob slightly clockwise from its most counter-clockwise position, which is the "normal" position. By aid of a screwdriver rotate the slotted shaft of the Electric Tuning switch located at the rear of the chassis base, so that the slotted shaft points in the direction of the word "Set-Up" (maximum clockwise rotation). Rotate the Volume control knob to its maximum clockwise position (maximum volume).
2. Apply between the chassis base (or ground binding post) of the receiver and the grid of the No. 6A8 modulator-oscillator tube, a modulated signal of 455 kilocycles from the test oscillator, using a 0.1 microfarad capacitor in series with the connection between the output terminal of the test oscillator and the grid of the No. 6A8 tube. Do not remove the chassis grid lead connecting to this tube. The ground (or low side) terminal of the test oscillator should be connected to either the chassis base or the ground binding post terminal.
3. Now, noting from Figure 1, the aligning capacitors for the first and second I. F. transformers, align the I. F. circuits in the following manner:

Secondary of second I. F. transformer.

Primary of second I. F. transformer.

Secondary of first I. F. transformer.

Primary of first I. F. transformer.

Adjusting the circuits to obtain maximum reading on the output meter, reducing the output of the test oscillator as required.

Radio Frequency Adjustments

The alignment of the radio frequency circuits in these receivers should be very carefully made and in the order specified.

Alignment of Short Wave Range (Also Referred to as "C" Range)

In aligning the radio frequency circuits for this range, replace the 0.1-microfarad capacitor which was placed in series with the test oscillator's output lead for the I. F. alignments, with a 400-ohm carbon type resistor. This lead should then be connected to the antenna binding post located on the rear of the receiver chassis. The ground terminal (or low side) of the test oscillator should be connected to the ground binding post on the receiver.

1. Rotate the Electric Tuning and Range Switch control knob to the Short Wave ("C") range position, and set the test oscillator's frequency and the receiver's tuning dial to 17 megacycles.
2. Adjust the oscillator's "C" range high frequency aligner for maximum output.
3. Adjust the antenna's "C" range high frequency aligner for maximum output and at the same time rotate the gang tuning capacitor back and forth through resonance until maximum output is obtained.

Alignment of Standard Broadcast Range (Also Referred to as "A" Range)

In aligning the radio frequency circuits for this range, replace the 400-ohm carbon type resistor in series with the test oscillator's output lead with a 200-micro-microfarad capacitor and align these circuits as follows:

1. Rotate the Electric Tuning and Range Switch control knob to the manual tuning, Standard Broadcast ("A") range position and set the test oscillator's frequency and the receiver's tuning dial to 1.5 megacycles.
2. Adjust the oscillator's "A" range high frequency aligner for maximum output.
3. Adjust the antenna's "A" range high frequency aligner for maximum output.
4. Set the test oscillator's frequency and the receiver's tuning dial to 0.6 megacycles.
5. Adjust the oscillator's "A" range low frequency aligner (series aligner) for maximum output, and at the same time rotate the gang tuning capacitor slightly back and forth through resonance until maximum output is obtained.
6. Reset both the test oscillator's frequency and receiver's tuning dial to 1.5 megacycles and repeat operations Nos. 2 and 3.

Wave Trap Adjustment

In adjusting the wave trap circuit, set the Electric Tuning and Range Switch control knob to the manual tuning, Standard Broadcast position (arrow on knob pointing in direction of letters "BR."). Set the dial pointer to 1000 kilocycles and the Electric Tuning Switch, located on the back of the receiver chassis, to the "Set-Up" position.

Connect a 200-micro-microfarad capacitor in series with the output terminal of the modulated test oscillator and the antenna binding post on the receiver, and the ground terminal of the test oscillator to the ground binding post on the receiver. Then, with the modulated test oscillator set at the frequency of the intermediate amplifier, 455 kilocycles, supply a fairly strong signal to the receiver and adjust the wave trap aligner until a minimum indication is obtained on the output meter.

IMPORTANT: When all the aligning adjustments have been completed, it is important that the Electric Tuning Switch (located on the rear of the receiver chassis) be reset to the "Operate" position.

PROCEDURE FOR OBTAINING REPRODUCTION FROM PHONOGRAPH RECORDS

FOR NO. 335 RECEIVERS ONLY

To equip these receivers for phonograph operation, it will be necessary to purchase and install in the receiver a Stromberg-Carlson, P-29697 Switch Assembly. The rear of the chassis base of these receivers is already drilled for mounting this switch assembly. Complete instructions on how to install and operate this switch are furnished with each P-29697 Switch Assembly.

To obtain the best quality of phonograph reproduction when using an electric pick-up and phonograph unit with this receiver, a Stromberg-Carlson Record Player is recommended. This record player is equipped with a correctly designed single record playing motor unit, and uses a crystal type pick-up in conjunction with a specially equalized circuit.

If the Stromberg-Carlson Record Player is not used and the electric pick-up to be used is of the high impedance type, it will be necessary to connect a low capacity shielded cable between the three-prong socket mounted in the P-29697 Switch Assembly and the pick-up. This shielded cable should be of the low capacity type, in order to prevent excessive cutting of high frequencies which is caused when a shielded cable having high capacity is used. The length of the shielded cable used should be kept as short as possible.

If a pick-up of the low impedance type is used, it will be necessary to connect a "matching transformer" between the three-prong socket mounted in the P-29697 Switch Assembly, and the pick-up. The transformer should be located as near to the receiver as possible, in which case it will not be necessary to use a shielded cable.

INSTRUCTIONS FOR SETTING UP THE ELECTRIC TUNING ARRANGEMENT

1. Before proceeding to set up the stations for electric tuning, the radio receiver should be turned "on" for approximately twenty to thirty minutes.
2. Set the Range Switch Control Knob to the manual tuning position for the Standard Broadcast range (arrow on knob pointing in direction of the letters BR.).

If the particular model is a No. 336-P Receiver, check the position of the "Radio-Phono" control knob. For radio reception this knob should be rotated so that the arrow on the knob points in the direction of the word "Radio".

3. Remove the list of station letters from the P-28781 package assembly which is tacked inside of the cabinet.
4. Remove the two screws which hold the electric tuning escutcheon plate (metal plate). Then, remove from the escutcheon, the strip of transparent material and the strip of paper on which the six stars are printed.
5. Remove the five screws which hold the electric tuning escutcheon to the front panel.
6. From the lists of stations, remove the call letters of the six stations which it is desired to set up for electric tuning. These six stations should preferably be selected and set up in the daytime so that the best service will be obtained at all times.

CAUTION: Each button adjustment for electric tuning has assigned frequency limits. These limits are designated for each adjustment on the cover plate which covers the electric tuning adjusting capacitors (visible when the electric tuning escutcheon is removed from the cabinet). The six stations should be selected so that the frequency of each station will be within the assigned frequency limits of its associated push button.

It will be noted that the station letters are printed on partially cut squares to facilitate ease in removing the desired station letters. In setting up these six favorite stations, the following order should be followed:

Looking at the front of the receiver, the station letters of the station having the highest frequency should be inserted into the farthest left-hand square of the escutcheon. Then, in successive order, according to the frequency, insert the station letters of the remaining five stations into the other five squares of the electric tuning escutcheon; the station letters of the station having the lowest frequency being inserted into the farthest right-hand square of the escutcheon.

After the six station call letters have been inserted into the escutcheon, the transparent strip should be replaced over the station call letters, and the escutcheon plate then fastened into its position on the electric tuning escutcheon by means of the two screws.

The tuning adjustments for the six favorite stations can now be made, starting with the station having the highest frequency and proceeding as follows:

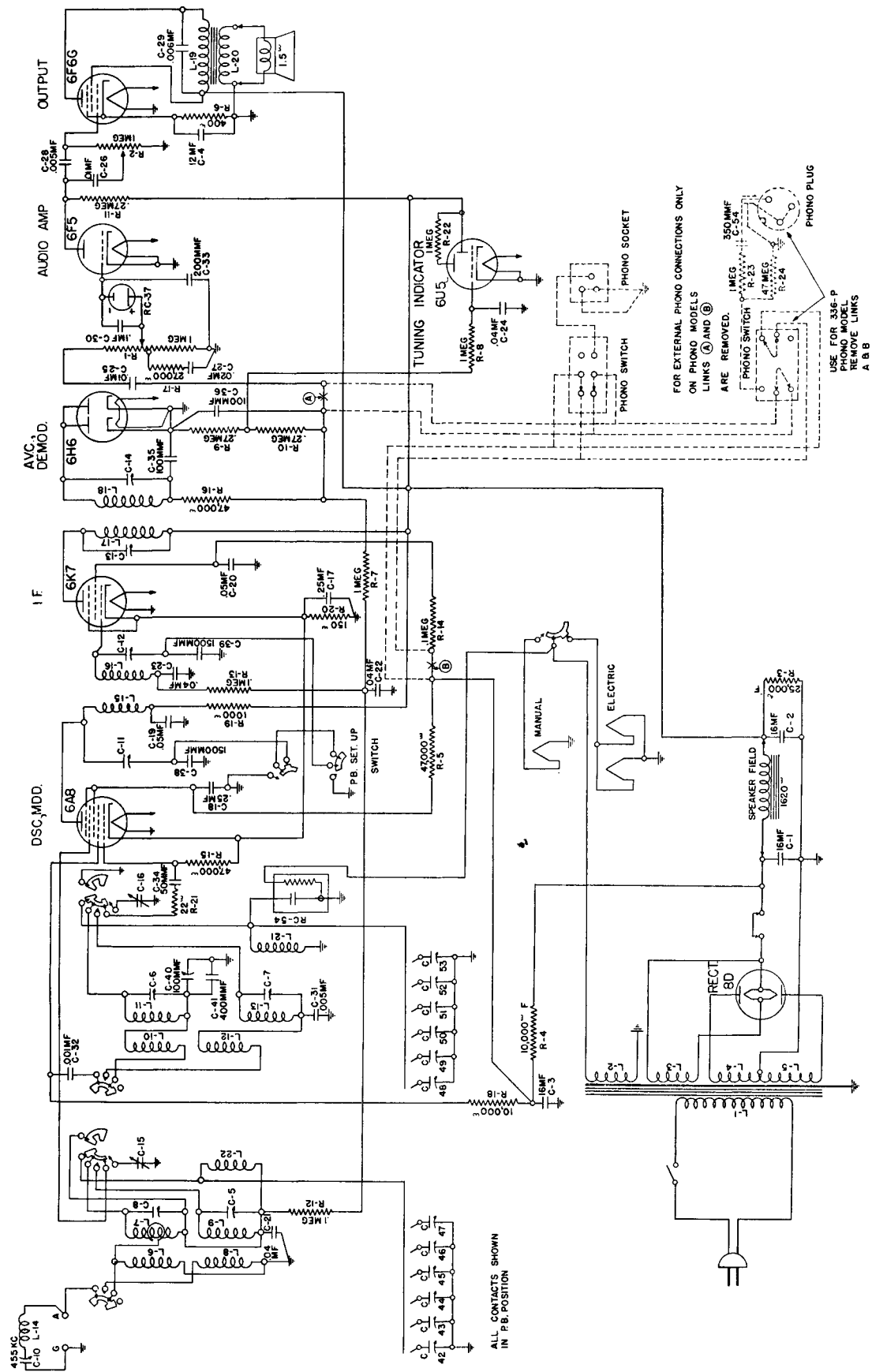

Fig. 2. Schematic Circuit of Receiver.

7. **IMPORTANT:** By aid of a screwdriver, rotate the slotted shaft of the Electric Tuning Switch, which is located at the rear of the chassis base, so that the slotted shaft points in the direction of the word, "Set-up" (maximum clockwise rotation).
8. With the receiver turned "on", and the Range Switch control knob set to the standard broadcast position (arrow on knob pointing in direction of letters BR.), tune the receiver in the conventional manner by means of the station selector knobs to that station having the highest frequency (of the six chosen for setting up in the electric tuning arrangement) and carefully note the program which it is broadcasting. Then, rotate the Range Switch control knob to the electric tuning position (arrow on knob pointing in direction of the small star).
9. With the electric tuning escutcheon still removed from the cabinet, push in the push button rod for the station having the highest frequency (provided, of course, that the station chosen has a frequency which is within the assigned frequency limits for this button). Now, looking in on the electric tuning unit, rotate by means of a small screwdriver, the screw of the oscillator (OSC.) tuning adjustment which is designated 1560 to 1030 kilocycles to the position where the desired station is received.

In order to check whether the program being received is from the desired station, simply rotate the Range Switch control knob to the manual tuning position (arrow on knob pointing in direction of letters BR.), and with the receiver tuned in manually to the desired station a quick check can be made; then, rotate the Range Switch control knob back to the electric tuning position. **Exact resonance with the desired station should be obtained by observing the tuning indicator.**

IMPORTANT: Always use the tuning indicator unit when setting up stations for electric tuning in order to determine when resonance with the desired station is obtained.

10. When the oscillator tuning adjustment has been properly made as mentioned in paragraph 9 above, the screw of the antenna (ANT.) tuning adjustment designated 1560 to 1030 kilocycles should be rotated to the position where exact resonance with the desired station is again obtained by observing the tuning indicator.

When these adjustments have been properly made, the station having the highest frequency is correctly set up for electric tuning selection.

11. Now proceed to set up the remaining five stations in the same manner as mentioned in Paragraphs 7, 8, 9 and 10 above, proceeding according to the frequency of the remaining stations.
12. **IMPORTANT:** When all of the adjustments have properly been made for the six desired stations, the slotted shaft of the Electric Tuning Switch located on the rear of the chassis base, should be rotated so that the slotted shaft points in the direction of the word, "Operate" (maximum counter-clockwise rotation).

The electric tuning escutcheon should then be refastened into its position on the cabinet by means of the five special screws.

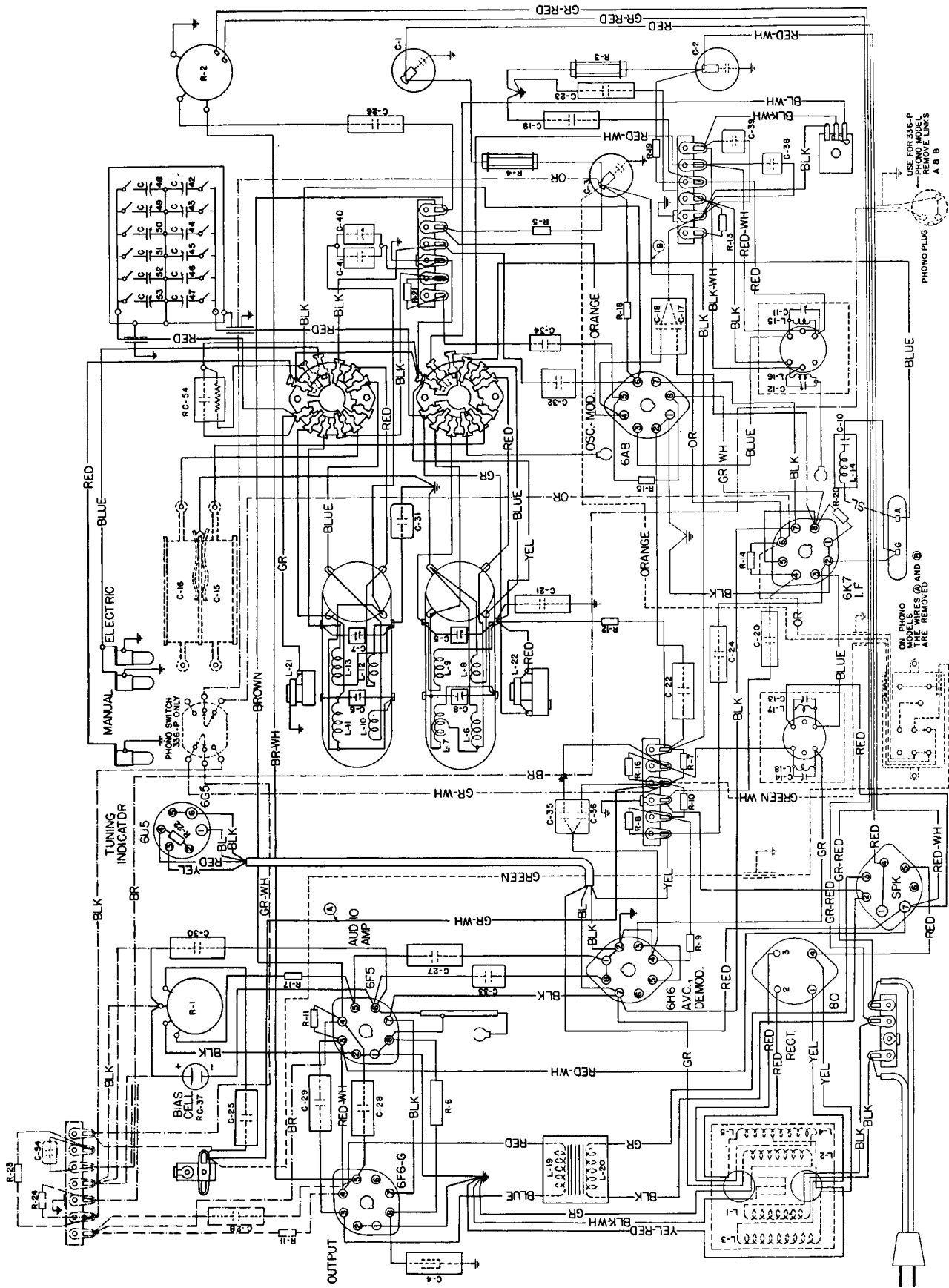

Fig. 3. Wiring Diagram of Chassis.

REPLACEMENT PARTS

Piece Number	Circuit Designation	Part
22988	.	Socket, 4 Prong
23517	.	Socket, 7 Prong
24402	C30	Capacitor, .1 Mfd.
24405	C21, C22, C23, C24	Capacitor, .04 Mfd.
24994	C19, C20	Capacitor, .05 Mfd.
25149	C25, C26	Capacitor, .01 Mfd.
25150	C27	Capacitor, .02 Mfd.
25301	.	Cord Assembly (Power Supply Cord for Phono Motor Unit)
25487	C32	Capacitor, Type W, .001 Mfd.
25533	C29	Capacitor, .006 Mfd.
25539	.	Socket, 8 Prong
26029	C11, C12, C13, C14	Aligning Capacitors, I. F. Transformer
26062	R4	Resistor, Type "F", 10,000 Ohms
26151	C28	Capacitor, .005 Mfd.
26313	R21	Resistor, Type "E", 22 Ohms
26323	R20	Resistor, Type "E", 150 Ohms
26333	R19	Resistor, Type "E", 1000 Ohms
26345	R18	Resistor, Type "E", 10,000 Ohms
26353	R5, R15, R16	Resistor, Type "E", 47,000 Ohms
26357	R12, R13, R14	Resistor, Type "E", .1 Megohm
26362	R9, R10, R11	Resistor, Type "E", .27 Megohm
26369	R7, R8, R22, R23	Resistor, Type "E", 1 Megohm
26512	C35, C36	Capacitor Assembly, Type "WD", (2-100 Mmfd.)
27081	C10	Tuning Capacitor, Wave Trap
27125	R3	Resistor, Type "F", 25,000 Ohms
27149	L14	Wave Trap Coil
27305	C34	Capacitor, Type "O", 50 Mmfd.
27311	R2	Potentiometer, Off-On-Tone Control
27538	C31	Capacitor, Type "W", .005 Mfd.
27610	R1	Potentiometer, Volume Control
27615	R17	Resistor, Type "EI", 27,000 Ohms
27685	C4	Electrolytic Capacitor, 20 Mfd., 25 Volts
27998	C33	Capacitor, Type "O", 200 Mmfd.
28025	.	Dial Lamp
28652	.	Cord (Power Supply)
28670	C15, C16	Gang Tuning Capacitor and Bracket Assembly
28692	.	Dial
28694	.	Dial Lamp Socket Assembly
28695	.	Dial Pointer
28696	C37	Bias Cell
28730	C1	Electrolytic Capacitor, 16 Mfd., 450 Volts (Used only on No. 335 Receivers' Chassis)
28731	C3	Electrolytic Capacitor, 16 Mfd., 300 Volts (Used only on No. 335 Receivers' Chassis)
28732	C2	Electrolytic Capacitor, 16 Mfd., 300 Volts (Used only on No. 335 Receivers' Chassis)
28757	.	Tuning Drive Assembly
28758	R6	Resistor, Type "BW", 400 Ohms
28759	L19, L20	Output Transformer
28805	C5, C6, C7	H. F. Aligning Capacitors, Antenna and Oscillator Transformers
28806	C8	H. F. Aligning Capacitor, Antenna Transformer
28810	L15, L16	First I. F. Transformer
28820	.	Range Switch
28821	.	Electric Tuning Cable Assembly
28822	.	Electric Tuning Cable Assembly
28824	.	Electric Tuning Switch
28841	C38, C39	Capacitor, Type "W", .0015 Mfd.
28848	L22	Coil Assembly, Antenna Shunt
28849	L21	Coil Assembly, Oscillator Shunt
28854	L17, L18	Second I. F. Transformer
28857	C40	L. F. Aligning Capacitor ("A" Range)
28858	C41	Capacitor, 370 Mmfd.
28859	RC54	Oscillator Compensator Unit Assembly
28871	C17, C18	Capacitor, .25 Mfd.
28882	L6, L7, L8, L9	Coil Assembly, Antenna Transformer
28883	L10, L11, L12, L13	Coil Assembly, Oscillator Transformer

28885	C42 to C53	. . .	Adjustable Capacitors and Switches for Electric Tuning
28903	L1, L2, L3, L4, L5	. . .	Power Transformer (50 to 60 Cycles Chassis)
28904	L1, L2, L3, L4, L5	. . .	Power Transformer (25 to 60 Cycles Chassis)
29096	Pilot Lamp Socket Assembly (For Station Letters)
29129	Spring for Tuning Drive
29137	Large Pulley
29522	C1	Electrolytic Capacitor, 16 Mfd., 450 Volts (Used only on No. 336-P Receiver)
29523	C3	Electrolytic Capacitor, 16 Mfd., 300 Volts (Used only on No. 336-P Receiver)
29524	C2	Electrolytic Capacitor, 16 Mfd., 300 Volts (Used only on No. 336-P Receiver)
29549	Tuning Indicator Cable
29733	Radio-Phono. Control Switch (Used only on No. 336-P Receiver)
29760	C54	Capacitor, Type "O", 350 Mmfd.

MISCELLANEOUS PARTS

27628	Felt Washer	Used on Volume, Off-On-Tone and Radio-Phono. Controls' Shafts
27629	Felt Washer	Used on Range Switch Control Shaft
27802	Knob	Used on Rapid Station Selector Control Shaft
27803	Knob	Used on Vernier Station Selector Control Shaft
27804	Knob	Used on Range Switch Control Shaft
28843	Knob	Used on Volume and Off-On-Tone Controls' Shafts
29084	Knob	Used on Radio-Phono. Control Shaft (Nos. 336-P Receivers only)