STUDER 900

Betriebs- und Serviceanleitung Operating and Service Instructions



Prepared and edited by:
STUDER Professional Audio AG
Technical Documentation
Althardstrasse 30
CH-8105 Regensdorf-Switzerland

We reserve the right to make alterations.

Copyright by STUDER Professional Audio AG
printed in Switzerland
Order No. 10.27.0163 (Ed. 1093)

STUDER is a registered trade mark of STUDER Professional Audio AG, Regensdorf

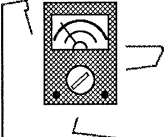
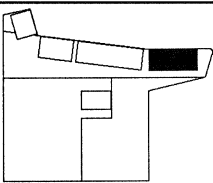
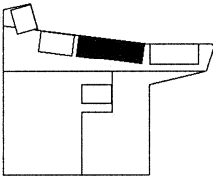
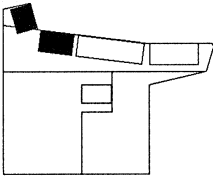
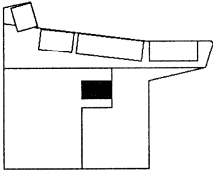
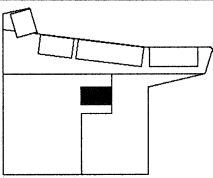
1	<p>Allgemeines Konzeption und Bezeichnungen Abmessungen Elektrische Daten</p>
2	<p>Blockschaltbild Audio gesamt Signalisation</p>
3	 <p>Einmessen Messgrundlagen Abgleich der Kanaleinschübe Abgleich der Anzeigeinstrumente</p>
4	 <p>Einschub-Module 1.911.... Funktion Schemata Bestückungspläne Positionslisten</p>
5	 <p>Einschub-Module 1.912.... Funktion Schemata Bestückungspläne Positionslisten</p>
6	 <p>Einschub-Module 1.913.... Funktion Schemata Bestückungspläne Positionslisten</p>
7	 <p>Modular Sub-Cards 1.914.... Funktion Schemata Bestückungspläne Positionslisten</p>
8	 <p>Europakarten und Stromversorgung 1.915.... / 1.916.... Schemata Bestückungspläne Positionslisten</p>
9	<p>Anschlussfeld Anschlussbelegungen Patch Panel</p>
10	<p>Verdrahtungslisten</p>

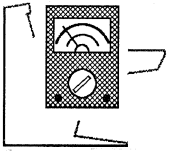
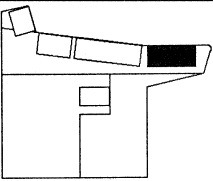
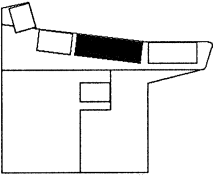
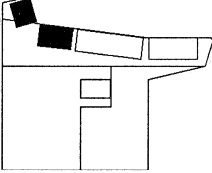
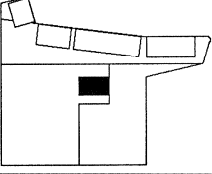
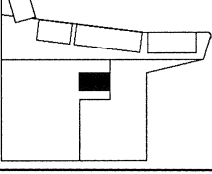
1	<p>General Information Layout and Designations Dimensions Electrical Specification</p>
2	<p>Block Diagrams Audio Block Diagram Signalization</p>
3	<div style="display: flex; align-items: center;">  <div style="vertical-align: top;"> <p>Alignment Instruction Measuring Principles Alignment Instructions for Plug-in Units Alignment Instructions for Level Meters</p> </div> </div>
4	<div style="display: flex; align-items: center;">  <div style="vertical-align: top;"> <p>Plug-in Units 1.911.... Function Circuit Diagrams Diagrams for Component Placement Parts List</p> </div> </div>
5	<div style="display: flex; align-items: center;">  <div style="vertical-align: top;"> <p>Plug-in Units 1.912.... Function Circuit Diagrams Diagrams for Component Placement Parts List</p> </div> </div>
6	<div style="display: flex; align-items: center;">  <div style="vertical-align: top;"> <p>Plug-in Units 1.913.... Function Circuit Diagrams Diagrams for Component Placement Parts List</p> </div> </div>
7	<div style="display: flex; align-items: center;">  <div style="vertical-align: top;"> <p>Modular Sub-Cards 1.914.... Function Circuit Diagrams Diagrams for Component Placement Parts List</p> </div> </div>
8	<div style="display: flex; align-items: center;">  <div style="vertical-align: top;"> <p>EU standard PCB + Power Supply 1.915..../1.916.... Circuit Diagram Diagrams for Component Placement Parts List</p> </div> </div>
9	<p>Connectors Pin Location Patch Panel</p>
10	<p>Wiring List</p>

CAUTION
RISK OF ELECTRIC SHOCK DO NOT OPEN
ATTENTION
RISQUE DE CHOC ELECTRIQUE NE PAS OUVRIR
ACHTUNG
GEFAHR: ELEKTRISCHER SCHLAG NICHT ÖFFNEN

To reduce the risk of electric shock, do not remove covers (or back). No user-serviceable parts inside. Refer servicing to qualified service personnel.

Afin de prévenir un choc électrique, ne pas enlever les couvercles (où l'arrière) de l'appareil. Il ne se trouve à l'intérieur aucune pièce pouvant être réparée par l'utilisateur.

Um die Gefahr eines elektrischen Schlages zu vermeiden, entfernen Sie keine Abdeckungen (oder Rückwand). Überlassen Sie die Wartung und Reparatur dem qualifizierten Fachpersonal.



This symbol is intended to alert the user to presence of uninsulated "**dangerous voltage**" within the apparatus that may be of sufficient magnitude to constitute a risk of electric shock to a person.

Ce symbole indique à l'utilisateur qu'il existe à l'intérieur de l'appareil des "**tensions dangereuses**". Ces tensions élevées entraînent un risque de choc électrique en cas de contact.

Dieses Symbol deutet dem Anwender an, dass im Geräteinnern die Gefahr der Berührung von "**gefährlicher Spannung**" besteht. Die Größe der Spannung kann zu einem elektrischen Schlag führen.



This symbol is intended to alert the user to the presence of **important instructions** for operating and maintenance in the enclosed documentation.

Ce symbole indique à l'utilisateur que la documentation jointe contient d'**importantes instructions** concernant le fonctionnement et la maintenance.

Dieses Symbol deutet dem Anwender an, dass die beigelegte Dokumentation **wichtige Hinweise** für Betrieb und Wartung beinhaltet.

CAUTION:	Lithium Battery. Danger of explosion by incorrect handling. Replace by battery of the same make and type only.
ATTENTION:	Pile au lithium. Danger d'explosion en cas de manipulation incorrecte. Ne remplacer que par un modèle de même type.
ACHTUNG:	Explosionsgefahr bei unsachgemäßem Auswechseln der Lithiumbatterie. Nur durch den selben Typ ersetzen.
ADVARSEL:	Lithiumbatteri. Eksplosionsfare. Udskiftning må kun foretages af en sagkyndig og som beskrevet i servicemanualen (DK).

FIRST AID

(in case of electric shock)

1. Separate the person as quickly as possible from the electric power source:
 - by switching off the equipment
 - or by unplugging or disconnecting the mains cable
 - pushing the person away from the power source by using dry insulating material (such as wood or plastic).
 - After having sustained an electric shock, always consult a doctor.

WARNING!

DO NOT TOUCH THE PERSON OR HIS CLOTHING BEFORE THE POWER IS TURNED OFF, OTHERWISE YOU STAND THE RISK OF SUSTAINING AN ELECTRIC SHOCK AS WELL!

2. If the person is unconscious
 - check the pulse,
 - reanimate the person if respiration is poor,
 - lay the body down and turn it to one side, call for a doctor immediately.

PREMIERS SECOURS

(en cas d'électrocution)

1. Si la personne est dans l'impossibilité de se libérer:
 - Couper l'interrupteur principal
 - Couper le courant
 - Repousser la personne de l'appareil à l'aide d'un objet en matière non conductrice (matière plastique ou bois)
 - Après une électrocution, consulter un médecin.

ATTENTION!

NE JAMAIS TOUCHER UNE PERSONNE QUI EST SOUS TENSION, SOUS PEINE DE SUBIR EGALEMENT UNE ELECTROCUTION.

2. En cas de perte de connaissance de la personne électrocutée:
 - Contrôler le pouls
 - Si nécessaire, pratiquer la respiration artificielle
 - Placer l'accidenté sur le flanc et consulter un médecin.

ERSTE HILFE

(bei Stromunfällen)

1. Bei einem Stromunfall die betroffene Person so rasch wie möglich vom Strom trennen:
 - Durch Ausschalten des Gerätes
 - Ziehen oder Unterbrechen der Netzzuleitung
 - Betroffene Person mit isoliertem Material (Holz, Kunststoff) von der Gefahrenquelle wegstoßen
 - Nach einem Stromunfall sollte immer ein Arzt aufgesucht werden.

ACHTUNG!

EINE UNTER SPANNUNG STEHENDE PERSON DARF NICHT BERÜHRT WERDEN. SIE KÖNNEN DABEI SELBST ELEKTRISIERT WERDEN!

2. Bei Bewusstlosigkeit des Verunfallten:
 - Puls kontrollieren,
 - bei ausgesetzter Atmung künstlich beatmen,
 - Seitenlagerung des Verunfallten vornehmen und Arzt verständigen.

Installation, Betrieb und Entsorgung

Vor der Installation des Gerätes müssen die hier aufgeführten und auch die weiter in dieser Anleitung mit \triangle bezeichneten Hinweise gelesen und während der Installation und des Betriebes beachtet werden.

Das Gerät und sein Zubehör ist auf allfällige Transportschäden zu untersuchen.

Ein Gerät, das mechanische Beschädigung aufweist oder in welches Flüssigkeit oder Gegenstände eingedrungen sind, darf nicht ans Netz angeschlossen oder muss sofort durch Ziehen des Netzsteckers vom Netz getrennt werden. Das Öffnen und Instandsetzen des Gerätes darf nur vom Fachpersonal unter Einhaltung der geltenden Vorschriften durchgeführt werden.

Falls dem Gerät kein konfektioniertes Netzkabel beiliegt, muss dieses durch eine Fachperson unter Verwendung der mitgelieferten Kabel-Gerätesteckdose IEC320/C13 oder IEC320/C19 und unter Berücksichtigung der einschlägigen, im jeweiligen Lande geltenden Bestimmungen angefertigt werden; siehe Bild unten.

Vor Anschluss des Netzkabels an die Netzsteckdose muss überprüft werden, ob die Stromversorgungs- und Anschlusswerte des Gerätes (Netzspannung, Netzfrequenz) innerhalb der erlaubten Toleranzen liegen. Die im Gerät eingesetzten Sicherungen müssen den am Gerät angebrachten Angaben entsprechen.

Ein Gerät mit einem dreipoligen Gerätestecker (Gerät der Schutzklasse I) muss an eine dreipolige Netzsteckdose angeschlossen und somit das Gerätegehäuse mit dem Schutzleiter der Netzinstallation verbunden werden (Für Dänemark gelten Starkstrombestimmungen, Abschnitt 107).

Installation, Operation, and Waste Disposal

Before you install the equipment, please read and adhere to the following recommendations and all sections of these instructions marked with \triangle .

Check the equipment for any transport damage.

A unit that is mechanically damaged or which has been penetrated by liquids or foreign objects must not be connected to the AC power outlet or must be immediately disconnected by unplugging the power cable. Repairs must only be performed by trained personnel in accordance with the applicable regulations.

Should the equipment be delivered without a matching mains cable, the latter has to be prepared by a trained person using the attached female plug (IEC320/C13 or IEC320/C19) with respect to the applicable regulations in your country - see diagram below.

Before connecting the equipment to the AC power outlet, check that the local line voltage matches the equipment rating (voltage, frequency) within the admissible tolerance. The equipment fuses must be rated in accordance with the specifications on the equipment.

Equipment supplied with a 3-pole appliance inlet (equipment conforming to protection class I) must be connected to a 3-pole AC power outlet so that the equipment cabinet is connected to the protective earth conductor of the AC supply (for Denmark the Heavy Current Regulations, Section 107, are applicable).

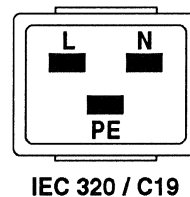
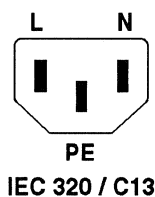

Female plug (IEC320), view from contact side:

L	live; brown	National American Standard: black
N	neutral; blue	white
PE ...	protective earth; green and yellow	green

Connecteur femelle (IEC320), vue de la face aux contacts:

L.....	phase, brun	Standard National Américain: noir
N.....	neutre, bleu	blanc
PE....	terre protective; vert et jaune	vert

Ansicht auf Steckkontakte der Kabel-Gerätesteckdose (IEC320):

L.....	Polleiter, braun	USA-Standard: schwarz
N.....	Neutralleiter, hellblau	weiss
PE....	Schutzleiter, gelb/grün	grün

Bei der Installation des Gerätes muss **vermieden** werden, dass:

- das Gerät Regen, Feuchtigkeit, direkter Sonneneinstrahlung oder übermässiger Wärmestrahlung von Wärmequellen (Heizgeräte, Heizungen, Spotlampen) ausgesetzt wird
- die für den Betrieb des Gerätes benötigte Luftzirkulation beeinträchtigt und dadurch die zulässige maximale Lufttemperatur der Geräteumgebung überschritten wird (Wärmestau)
- die Belüftungsöffnungen des Gerätes blockiert oder abgedeckt werden.

Das Gerät und seine Verpackung darf nur sachgerecht entsorgt werden. Alle Teile des Gerätes, die gefährliche Stoffe (Quecksilber, Cadmium) enthalten, müssen als Sondermüll behandelt werden.

Verbrauchte Batterien und Akkus müssen dem Hersteller zur Entsorgung zurückgegeben oder entsprechend den spezifischen Bestimmungen Ihres Landes fachgerecht entsorgt werden.

Wartung und Reparatur

Durch Entfernen von Gehäuseteilen, Abschirmungen etc. werden stromführende Teile freigelegt. Aus diesem Grund müssen u.a. die folgenden Grundsätze beachtet werden:

Eingriffe in das Gerät dürfen nur von Fachpersonal unter Einhaltung der geltenden Vorschriften vorgenommen werden.

Vor Entfernen von Gehäuseteilen muss das Gerät ausgeschaltet und vom Netz getrennt werden.

Bei geöffnetem, vom Netz getrenntem Gerät dürfen Teile mit gefährlichen Ladungen (z. B. Kondensatoren, Bildröhren) erst nach kontrollierter Entladung, heiße Bauteile (Leistungshalbleiter, Kühlkörper etc.) erst nach deren Abkühlen berührt werden.

Bei Wartungsarbeiten am geöffneten, unter Netzspannung stehenden Gerät dürfen blanke Schaltungsteile und metallene Halbleitergehäuse weder direkt noch mit einem nichtisolierten Werkzeug berührt werden.

Zusätzliche Gefahren bestehen bei unsachgemässer Handhabung besonderer Komponenten:

- **Explosionsgefahr** bei Lithiumzellen, Elektrolyt-Kondensatoren und Leistungshalbleitern
- **Implosionsgefahr** bei evakuierten Anzeigeeinheiten
- **Strahlungsgefahr** bei Lasereinheiten (nichtionisierend), Bildröhren (ionisierend)
- **Verätzungsgefahr** bei Anzeigeeinheiten (LCD) und Komponenten mit flüssigem Elektrolyt.

Solche Komponenten dürfen nur von dafür ausgebildetem Fachpersonal unter Verwendung von vorgeschriebenen Schutzmitteln (u.a. Schutzbrille, Handschuhe) gehandhabt werden.

The equipment installation **must satisfy** the following requirements:

- Protection against rain, humidity, direct solar irradiation or strong thermal radiation from heat sources (heaters, radiators, spotlights).
- Unobstructed air circulation so that the maximum air temperature in the equipment environment will not be exceeded (no heat accumulation).
- Ventilation louvers of the equipment must not be blocked or covered.

The equipment and its packing materials should ultimately be disposed off in accordance with the applicable regulations only. All parts of the equipment that contain hazardous substances (mercury, cadmium) must be treated as toxic waste.

Weak batteries or exhausted rechargeable batteries must be returned to the manufacturer for competent disposal or must be disposed of in accordance with the environmental protection regulations applicable for your country.

Maintenance and Repair

The removal of housing parts, shields, etc. exposes energized parts. For this reason the following precautions should be observed:

Maintenance should only be performed by trained personnel in accordance with the applicable regulations. The equipment should be switched off and disconnected from the AC power outlet before any housing parts are removed.

Even after the equipment has been disconnected from the power, parts with hazardous charges (e.g. capacitors, picture tubes) should only be touched after they have been properly discharged. Hot components (power semiconductors, heat sinks, etc.) should only be touched after they have cooled off.

If maintenance is performed on a unit that is opened and switched on, no uninsulated circuit components and metallic semiconductor housings should be touched neither with your bare hands nor with uninsulated tools.

Certain components pose additional hazards:

- **Explosion hazard** from lithium batteries, electrolytic capacitors and power semiconductors
- **Implosion hazard** from evacuated display units
- **Radiation hazard** from laser units (non-ionizing), picture tubes (ionizing)
- **Caustic effect** of display units (LCD) and such components containig liquid electrolyte.

Such components should only be handled by trained personnel who are properly protected (e.g. by goggles, gloves).

Für Wartung und Reparatur der sicherheitsrelevanten Teile des Gerätes darf nur Ersatzmaterial nach Herstellerspezifikation verwendet werden.

Das Gerät muss ordnungsgemäss und regelmässig gewartet und somit in sicherem Zustand erhalten werden. Bei ungenügender Wartung oder bei Änderungen der sicherheitsrelevanten Teile des Gerätes erlischt die entsprechende Produkthaftung des Herstellers.

For maintenance work and repair on components that influence the equipment safety, only replacement material conforming to the manufacturer's specifications may be used.

The equipment should be properly serviced in regular intervals and be maintained in safe operating condition. If the equipment is not properly maintained or if any modifications are made to components that influence safety, the manufacturer's product liability gets void.

Elektrostatische Entladung (ESD) bei Wartung und Reparatur

Electrostatic Discharge (ESD) during Maintenance and Repair

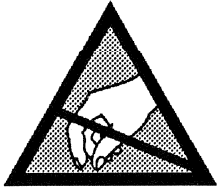
ATTENTION:

Observe precautions for handling devices sensitive to electrostatic discharge!

ATTENTION:

Respecter les précautions d'usage concernant la manipulation de composants sensibles à l'électricité statique!

ACHTUNG:

Vorsichtsmassnahmen bei Handhabung elektrostatisch entladungsgefährdeter Bauelemente beachten!

Viele ICs und andere Halbleiter sind empfindlich gegen elektrostatische Entladung (ESD). Unfachgerechte Behandlung von Baugruppen mit solchen Komponenten bei Wartung und Reparatur kann deren Lebensdauer drastisch vermindern.

Bei der Handhabung der ESD-empfindlichen Komponenten sind u.a. folgende Regeln zu beachten:

- ESD-empfindliche Komponenten dürfen ausschliesslich in dafür bestimmten und bezeichneten Verpackungen gelagert und transportiert werden.
- Unverpackte, ESD-empfindliche Komponenten dürfen nur in den dafür eingerichteten Schutzzonen (EPA, z.B. Gebiet für Feldservice, Reparatur- oder Serviceplatz) gehandhabt und nur von Personen berührt werden, die durch ein Handgelenkband mit Serienwiderstand mit dem Massepotential des Reparatur- oder Serviceplatzes verbunden sind. Das gewartete oder reparierte Gerät wie auch Werkzeuge, Hilfsmittel, EPA-taugliche (elektrisch leitende) Arbeits-, Ablage- und Bodenmatten müssen ebenfalls mit diesem Potential verbunden sein.
- Die Anschlüsse der ESD-empfindlichen Komponenten dürfen unkontrolliert weder mit elektrostatisch aufladbaren (Gefahr von Spannungsdurchschlag), noch mit metallischen Oberflächen (Schockentladungsgefahr) in Berührung kommen.
- Um undefinierte transiente Beanspruchung der Komponenten und deren eventuelle Beschädigung durch unerlaubte Spannung oder Ausgleichsströme zu vermeiden, dürfen elektrische Verbindungen nur am abgeschalteten Gerät und nach dem Abbau allfälliger Kondensatorladungen hergestellt oder getrennt werden.

Many ICs and semiconductors are sensitive to electrostatic discharge (ESD). The life of components containing such elements can be drastically reduced by improper handling during maintenance and repair work.

Please observe the following rules when handling ESD sensitive components:

- ESD sensitive components should only be stored and transported in the packing material specifically provided for this purpose.
- Unpacked ESD sensitive components should only be handled in ESD protected areas (EPA, e.g. area for field service, repair or service bench) and only be touched by persons who wear a wristlet that is connected to the ground potential of the repair or service bench by a series resistor. The equipment to be repaired or serviced and all tools, aids, as well as electrically semiconducting work, storage and floor mats should also be connected to this ground potential.
- The terminals of ESD sensitive components must not come in uncontrolled contact with electrostatically chargeable (voltage puncture) or metallic surfaces (discharge shock hazard).
- To prevent undefined transient stress of the components and possible damage due to inadmissible voltages or compensation currents, electrical connections should only be established or separated when the equipment is switched off and after any capacitor charges have decayed.

SMD-Bauelemente

Der Austausch von SMD-Bauelementen ist ausschliesslich geübten Fachleuten vorbehalten. Für verwüstete Platinen können keine Ersatzansprüche geltend gemacht werden. Beispiele für korrekte und falsche SMD-Lötverbindungen in der Abbildung weiter unten.

Bei Studer werden keine handelsüblichen SMD-Teile bewirtschaftet. Für Reparaturen sind die notwendigen Bauteile lokal zu beschaffen. Die Spezifikationen aller Komponenten finden Sie in den Positionslisten im Schemateil.

Spezialkomponenten sind in der Positionsliste mit einer Artikelnummer versehen und können bei Studer unter dieser Nummer bezogen werden.

SMD Components

SMDs should only be replaced by skilled specialists. No warranty claims will be accepted for circuit boards that have been ruined. Proper and improper SMD soldering joints are depicted below.

Studer does not keep any commercially available SMDs in stock. For repairs the corresponding devices should be purchased locally. The specifications of all components can be found in the parts lists in the diagram section.

Special components having a part number in the parts list can be ordered from Studer by specifying this number.

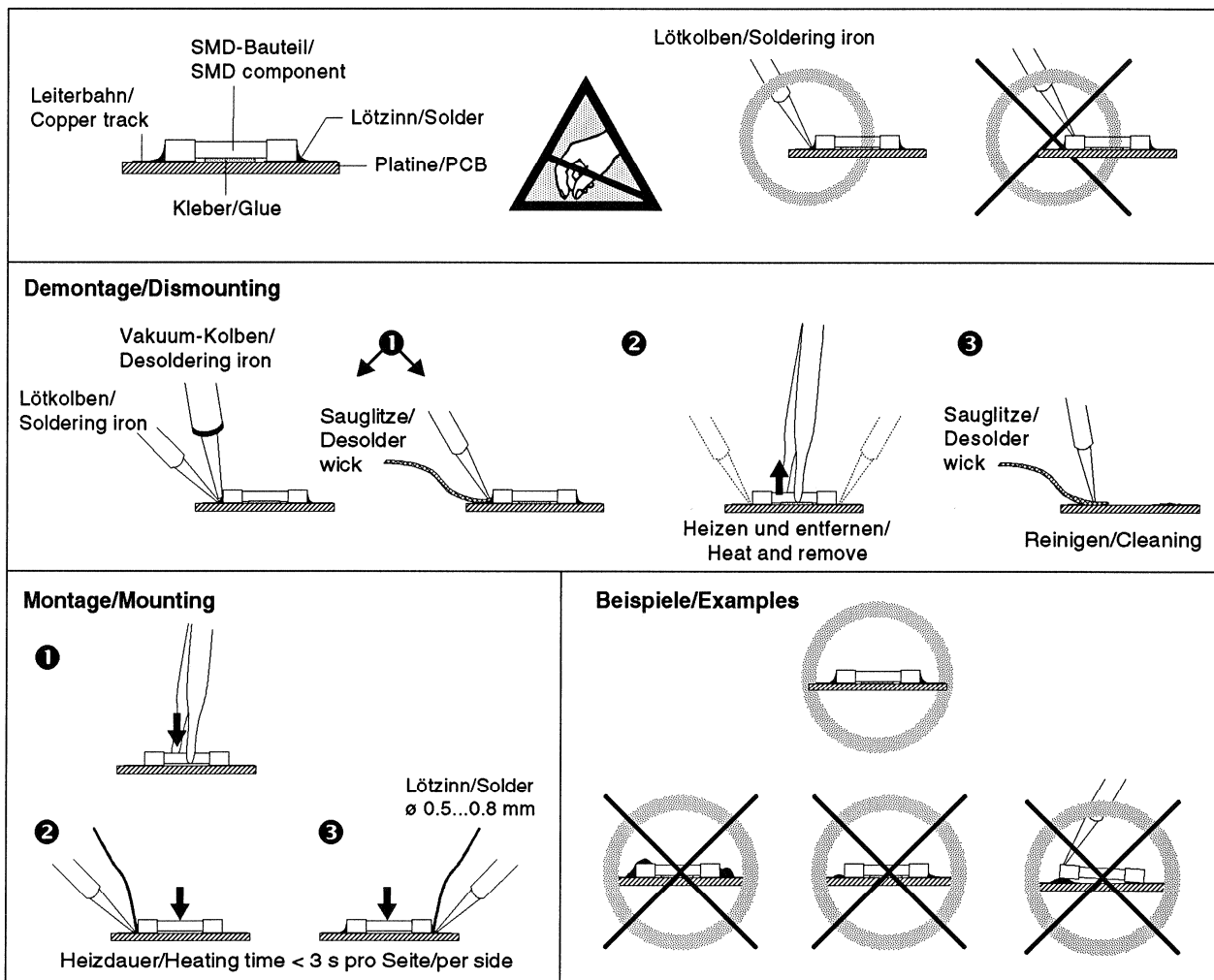

Störstrahlung und Störfestigkeit

Das Gerät entspricht den Schutzanforderungen auf dem Gebiet der elektromagnetischen Phänomene, die u.a. in den Richtlinien 89/336/EWG und FCC, Part 15, aufgeführt sind :

1. Die vom Gerät erzeugten elektromagnetischen Ausstrahlungen sind soweit begrenzt, dass ein bestimmungsgemässer Betrieb anderer Geräte und Systeme möglich ist.
2. Das Gerät weist eine angemessene Festigkeit gegen elektromagnetische Störungen auf, so dass sein bestimmungsgemässer Betrieb möglich ist.

Das Gerät wurde getestet und erfüllt die Bedingungen der im Kapitel "Technische Daten" aufgeführten EMV-Standards. Die Limiten dieser Standards gewährleisten mit einer angemessenen Wahrscheinlichkeit sowohl einen Schutz der Umgebung wie auch entsprechende Störfestigkeit des Gerätes. Eine absolute Garantie, dass keine unerlaubte elektromagnetische Beeinträchtigung während des Gerätebetriebes entsteht, ist jedoch nicht gegeben.

Um die Wahrscheinlichkeit solcher Beeinträchtigung weitgehend auszuschliessen, sind u.a. folgende Massnahmen zu beachten:

- Installieren Sie das Gerät gemäss den Angaben in der Bedienungsanleitung, und verwenden Sie das mitgelieferte Zubehör.
- Verwenden Sie im System und in der Umgebung, in denen das Gerät eingesetzt ist, nur Komponenten (Anlagen, Geräte), die ihrerseits die Anforderungen der obenerwähnten Standards erfüllen.
- Sehen Sie ein Erdungskonzept des Systems vor, das sowohl die Sicherheitsanforderungen (die Erdung der Geräte gemäss Schutzklasse I mit einem Schutzleiter muss gewährleistet sein), wie auch die EMV-Belange berücksichtigt. Bei der Entscheidung zwischen stern- oder flächenförmiger bzw. kombinierter Erdung sind Vor- und Nachteile gegeneinander abzuwägen.
- Benutzen Sie abgeschirmte Kabel für die Verbindungen, für welche eine Abschirmung vorgesehen ist. Achten Sie auf einwandfreie, grossflächige, korrosionsbeständige Verbindung der Abschirmung zum entsprechenden Steckeranschluss bzw. zum Steckergehäuse. Beachten Sie, dass eine nur an einem Ende angeschlossene Kabelabschirmung als Sende- bzw. Empfangsantenne wirken kann (z.B. bei wirksamer Kabellänge von 5 m oberhalb von 10 MHz), und dass die Flanken der digitalen Kommunikationssignale hochfrequente Aussendungen verursachen (z.B. LS- oder HC-Logik bis 30 MHz).
- Vermeiden Sie Bildung von Stromschleifen oder vermindern Sie deren unerwünschte Auswirkung, indem Sie deren Fläche möglichst klein halten und den darin fliessenden Strom durch Einfügen einer Impedanz (z.B. Gleichtaktdrossel) reduzieren.

Electromagnetic Compatibility

The equipment conforms to the protection requirements relevant to electromagnetic phenomena that are listed in the guidelines 89/336/EC and FCC, part 15.

1. The electromagnetic interference generated by the equipment is limited in such a way that other equipment and systems can be operated normally.
2. The equipment is adequately protected against electromagnetic interference so that it can operate correctly.

The equipment has been tested and conforms to the EMC standards applicable to residential, commercial and light industry, as listed in the section "Technical Data". The limits of these standards reasonably ensure protection of the environment and corresponding noise immunity of the equipment. However, it is not absolutely warranted that the equipment will not be adversely affected by electromagnetic interference during operation.

To minimize the probability of electromagnetic interference as far as possible, the following recommendations should be followed:

- Install the equipment in accordance with the operating instructions. Use the supplied accessories.
- In the system and in the vicinity where the equipment is installed, use only components (systems, equipment) that also fulfill the above EMC standards.
- Use a system grounding concept that satisfies the safety requirements (protection class I equipment must be connected with a protective ground conductor) that also takes into consideration the EMC requirements. When deciding between radial, surface or combined grounding, the advantages and disadvantages should be carefully evaluated in each case.
- Use shielded cables where shielding is specified. The connection of the shield to the corresponding connector terminal or housing should have a large surface and be corrosion-proof. Please note that a cable shield connected only single-ended can act as a transmitting or receiving antenna (e.g. with an effective cable length of 5 m, the frequency is above 10 MHz) and that the edges of the digital communication signals cause high-frequency radiation (e.g. LS or HC logic up to 30 MHz).
- Avoid current loops or reduce their adverse effects by keeping the loop surface as small as possible, and reduce the noise current flowing through the loop by inserting an additional impedance (e.g. common-mode rejection choke).

Class A Equipment - FCC Notice

This equipment has been tested and found to comply with the limits for a Class A digital device, pursuant to Part 15 of the FCC Rules. These limits are designed to provide a reasonable protection against harmful interference when the equipment is operated in a commercial environment. This equipment generates, uses, and can radiate radio frequency energy and, if not installed and used in accordance with the instruction manual, may cause harmful interference to radio communications. Operation of this equipment in a residential area is likely to cause harmful interference in which case the user will be required to correct the interference at his own expense.

Caution:

Any changes or modifications not expressly approved by the manufacturer could void the user's authority to operate the equipment. Also refer to relevant information in this manual.

CE-Konformitätserklärung

Wir,

Studer Professional Audio AG,
CH-8105 Regensdorf,

erklären in eigener Verantwortung, dass das in dieser Anleitung beschriebene Produkt

- 900, Mischpult,

auf das sich diese Erklärung bezieht, entsprechend den Bestimmungen der EU-Richtlinien und deren Ergänzungen

- Elektromagnetische Verträglichkeit (EMV):
89/336/EWG + 92/31/EWG + 93/68/EWG
- Niederspannung:
73/23/EWG, 93/68/EWG

mit den folgenden Normen und normativen Dokumenten übereinstimmt:

- Sicherheit:
Class I, EN 60065/1993 (IEC 65/1985)
- EMV:
EN 50081-1/1992; EN 50082-1/1992

Regensdorf, 16. Juni 1995



B. Hochstrasser, Geschäftsleiter

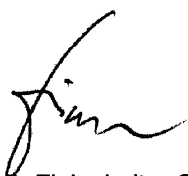

P. Fiala, Leiter QS

CE Declaration of Conformity

We,

Studer Professional Audio AG,
CH-8105 Regensdorf,

declare under our sole responsibility that the product described in this manual

- 900, Mixing Console,

to which this declaration relates, according to following regulations of EU directives and amendments

- Electromagnetic Compatibility (EMC):
89/336/EEC + 92/31/EEC + 93/68/EEC
- Low Voltage (LVD):
73/23/EEC + 93/68/EEC

is in conformity with the following standards or other normative documents:

- Safety:
Class I, EN 60065/1993 (IEC 65/1985)
- EMC:
EN 50081-1/1992; EN 50082-1/1992

Regensdorf, June 16, 1995

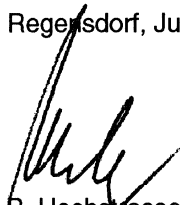

B. Hochstrasser, Managing Director



P. Fiala, Manager QA

KAPITEL 1: Allgemeines

1.	Gesamtansicht des Mischpultes	
1.1	Ansichtszeichnung	1
1.2	Liste aller Einschubmodule	3
2.	Abmessungen	
2.1	Chassisversionen	5
2.2	Querschnittzeichnungen	7
2.3	Masse der Einschubplätze	9
3.	Konzeption und Bezeichnungen	
3.1	Bezeichnung der Einschubplätze	10
3.2	Steckeranordnung und Bezeichnungen	10
3.3	Verbindungsprint Eingangseinheiten	13
3.4	Sammelschienenanschluss	14
3.5	Signalisation	15
3.6	Masseführung im Blickpunkt	21
4.	Elektrische Daten	
4.1	Pegel	26
4.2	Pegeldiagramm	27
4.3	Impedanzen	28
4.4	Frequenzgänge	28
4.5	Fremdspannungen	29
4.6	Klirrfaktor und Übersprechen	29
4.7	Stromversorgung	29

2. Abmessungen

2.1 Chassisversionen

Das Pultchassis wird in zwei Grundausführungen für 3 oder 4 Einschubsektionen gebaut. Mit Chassiseinheiten in zwei Breiten für 12 bzw. 16 Einschubreihen wird die individuelle Pultgröße realisiert. Ein Chassis für 12 Einheiten bietet zudem Platz für verschieden dimensionierte, 19" normierte Geräte.

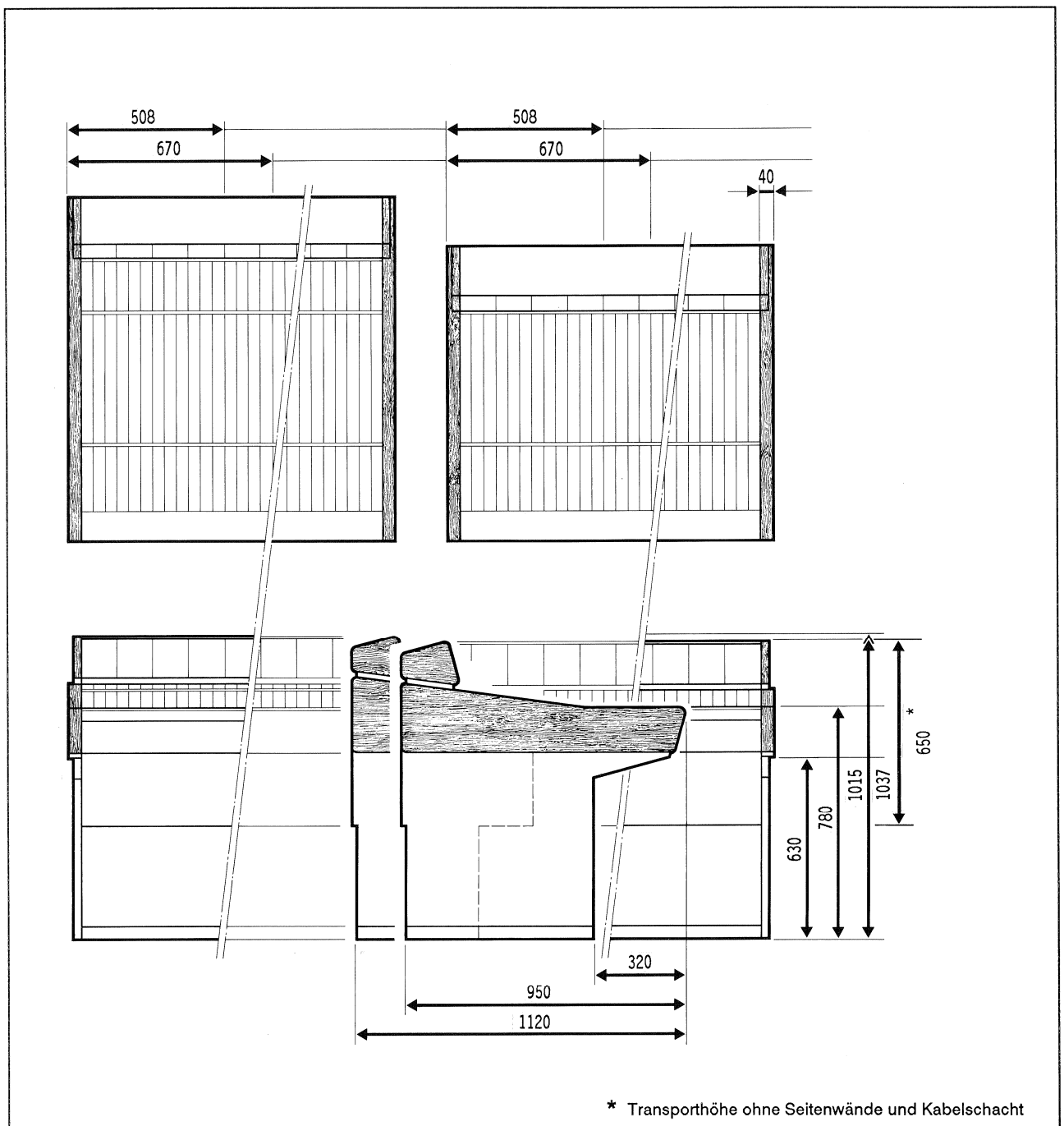
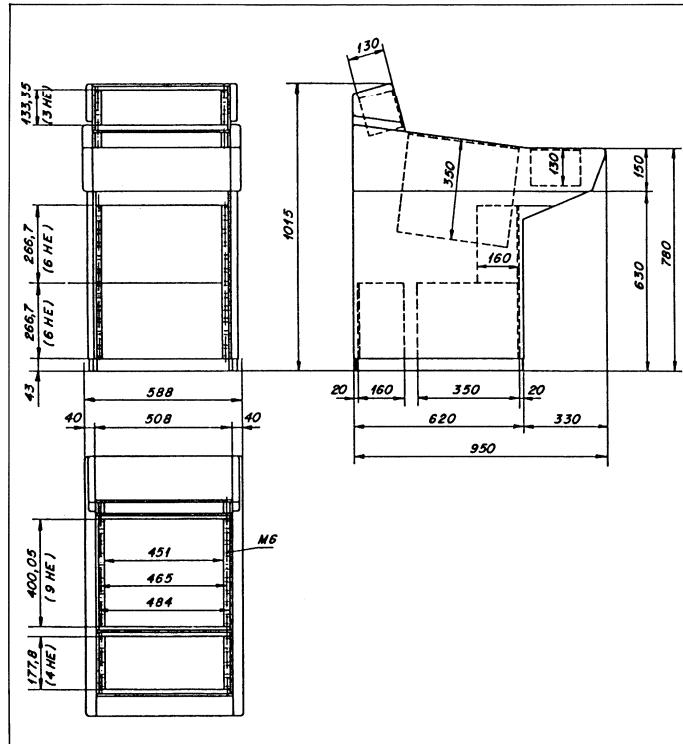

Fig. 1 Masszeichnungen der zwei Chassisbreiten für die beiden Grundversionen mit 3 bzw. 4 Einschubsektionen.

ALLGEMEINES

19" Chassis: Dieses Chassis entspricht der Grundeinheit für 12 Einheiten, bietet aber Platz für 19" normierte Geräte.



2.2 Querschnittzeichnung

Der Seitenriss zeigt die Pultversion mit 3 Einschubsektionen. Eine zusätzliche Routingsektion liegt zwischen Eingangs- und Meterpanel und hat die gleichen Dimensionen wie das Meterpanel.

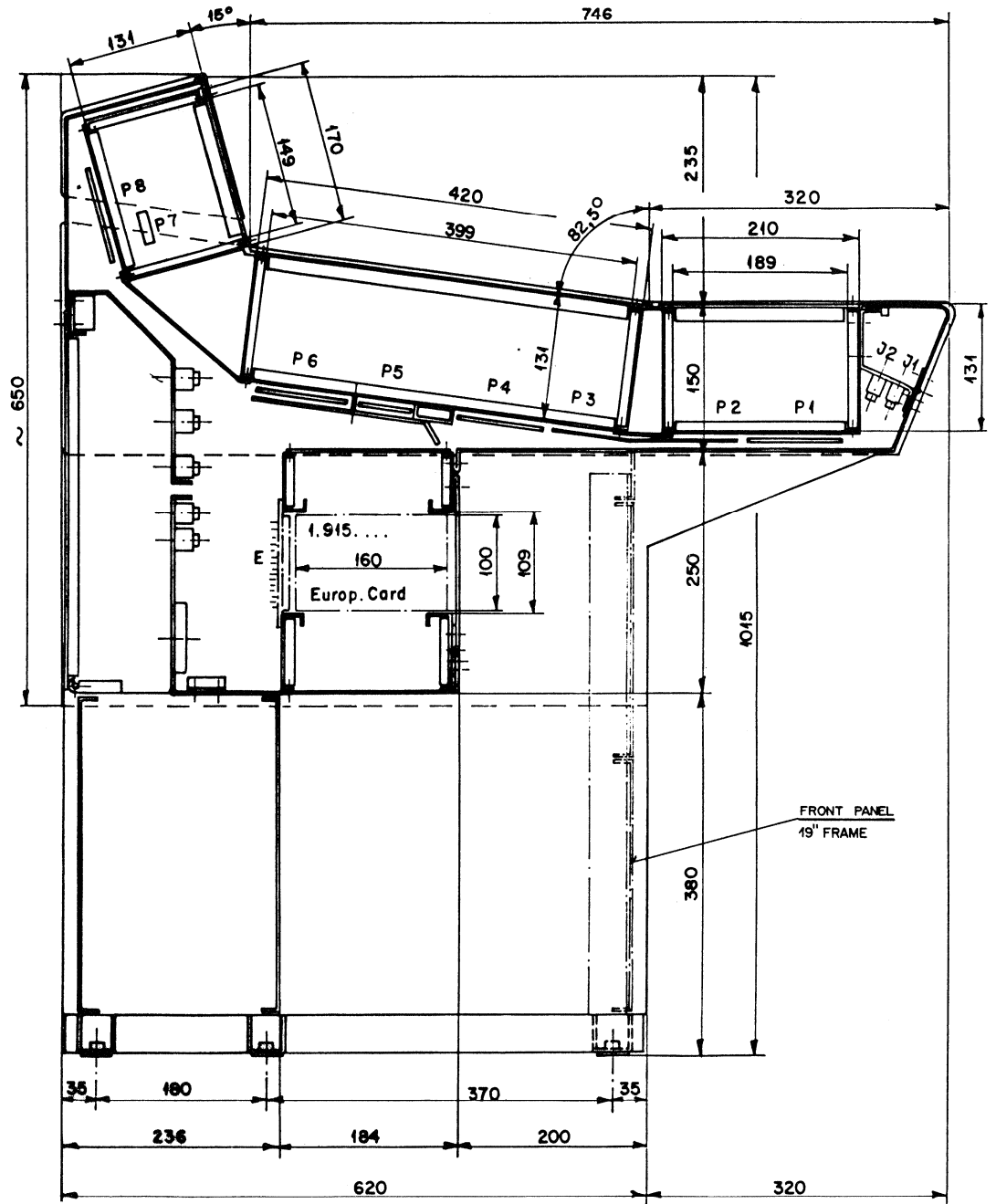

- | | | | | |
|-----------------|--------|---|---|-----------------------------|
| Stecker: | J1/J2 | → | Insert Field (Jack) | Masse in Millimetern |
| | P1 | → | Fader Input and Output | |
| | P2/P3 | → | Interconnection Fader - Input Unit | |
| | P4(P8) | → | Mains Bus | |
| | P5 | → | Intercom | |
| | P6 | → | Inputs | |
| | P7 | → | Meter Connection | |
| | X/D/S | → | Input/Output Connection Panel | |
| | E | → | Eurocards (Voltage Stabilizer, Line Amplifier etc.) | |

2.3 Masse der Einschubplätze

Wiederum ist die Mischpultversion mit 3 Einschubsektionen dargestellt. Eine 4. Sektion für erweitertes Routing hat die gleichen Dimensionen wie das Meterpanel.

Fadersektion 1.911.*

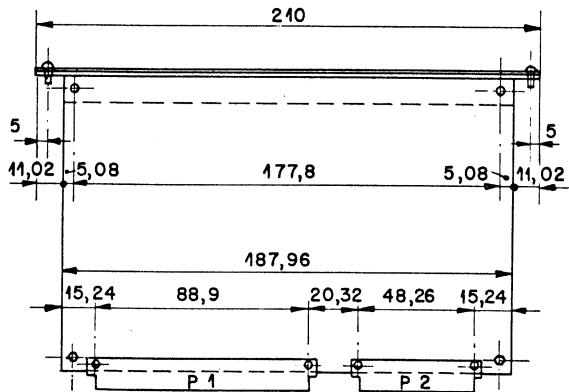

Eingangssektion 1.912.*

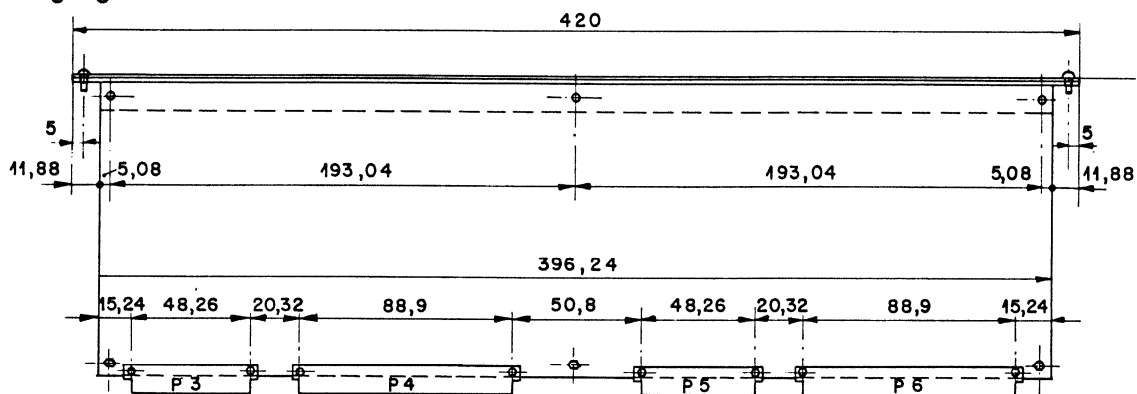

Meterpanel 1.913.*

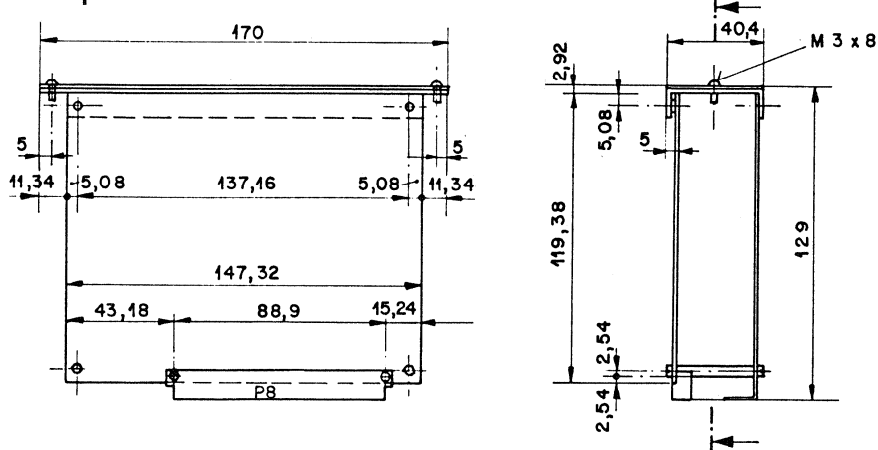

3. Konzeption und Bezeichnungen

Der modulare Aufbau der STUDER Regiepulte 900 ermöglicht eine dem Einzelfall angepasste Konzeption. Nach erfolgter Montage sind die Einschubmodule nur noch sehr eingeschränkt vertauschbar. Anschlussfeld und Verdrahtung werden für jeden Kunden individuell ausgelegt und in den Kapiteln 2, 9 und 10 des Handbuches dokumentiert. Als Orientierungshilfe für Struktur und Funktion des Regiepultes werden im Folgenden einige Grundsätze erläutert.

3.1 Bezeichnung der Einschubplätze

Auf einer Einschubreihe (entspricht einem Kanal) stehen 4 bis 5 Einschubplätze zur Verfügung. Die zugehörigen Baugruppen tragen Nummern mit folgenden Anfangsziffern:

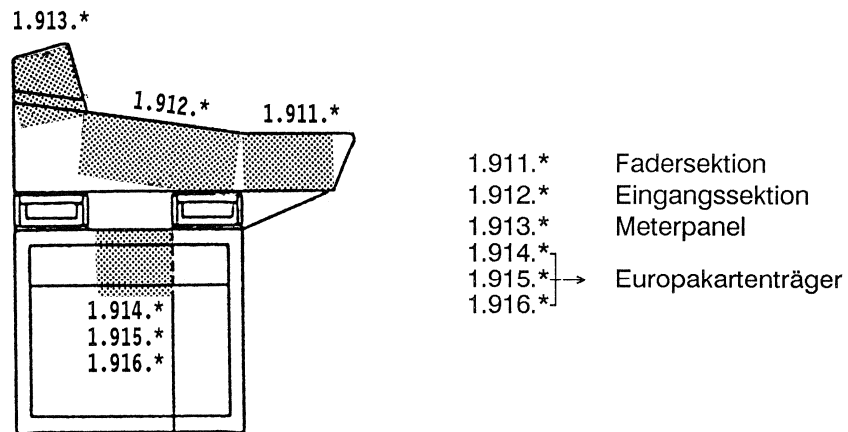

Die Europakarten sind mit den Anfangsziffern 1.915.* und 1.916.* bezeichnet. Die STUDER "Modular Sub Cards" (1.914.*) lassen sich auf einer Trägerkarte im Europakartenformat kombinieren und ebenfalls im Europakartenträger unterbringen.

3.2 Steckeranordnung und Bezeichnungen

Alle Stecker des Mischpultes haben eine Bezeichnung, die die Lage und den Steckertyp definiert. Die Bezeichnung eines Steckerplatzes setzt sich aus vier Ziffern mit folgenden Bedeutungen zusammen:

- | | |
|------------|---|
| 1. Ziffer: | Nummer des Pultchassis ¹⁾ |
| 2. Ziffer: | Abkürzung für den Steckertyp (vgl. Tabelle) |
| 3. Ziffer: | Vertikale Position ²⁾ |
| 4. Ziffer: | Horizontale Position ¹⁾ |

¹⁾ Numerierung von links nach rechts

²⁾ Pultoberseite: Numerierung von vorn nach hinten
Pultrückseite: Numerierung von oben nach unten

Abkürzungen für Steckertypen:

P1 / P4 / P6 / P8	32 pin Eurocard-Stecker	DIN 41612
P2 / P3 / P5	16 pin Eurocard-Stecker	DIN 41612
E	32 / 64 pin Eurocard-Stecker	DIN 41612
P7	10 / 16 / 26 pin Stecker	DIN 41651/MIL
J	Stereo Jack, Ø 6,3mm	
X	XLR Stecker	
S	Siemens Multipinstecker	
D	D Typ Multipinstecker	

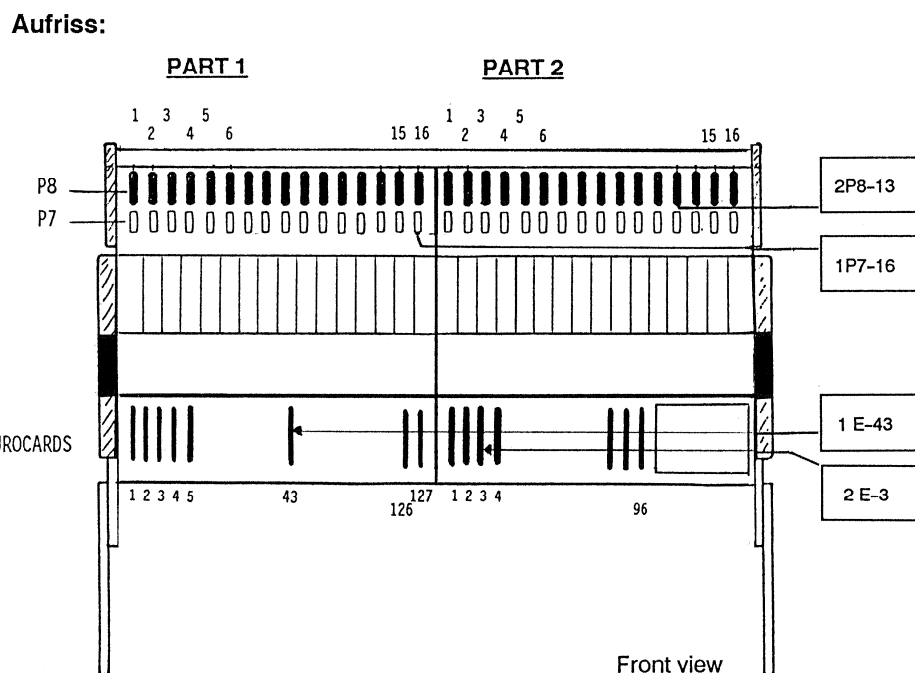
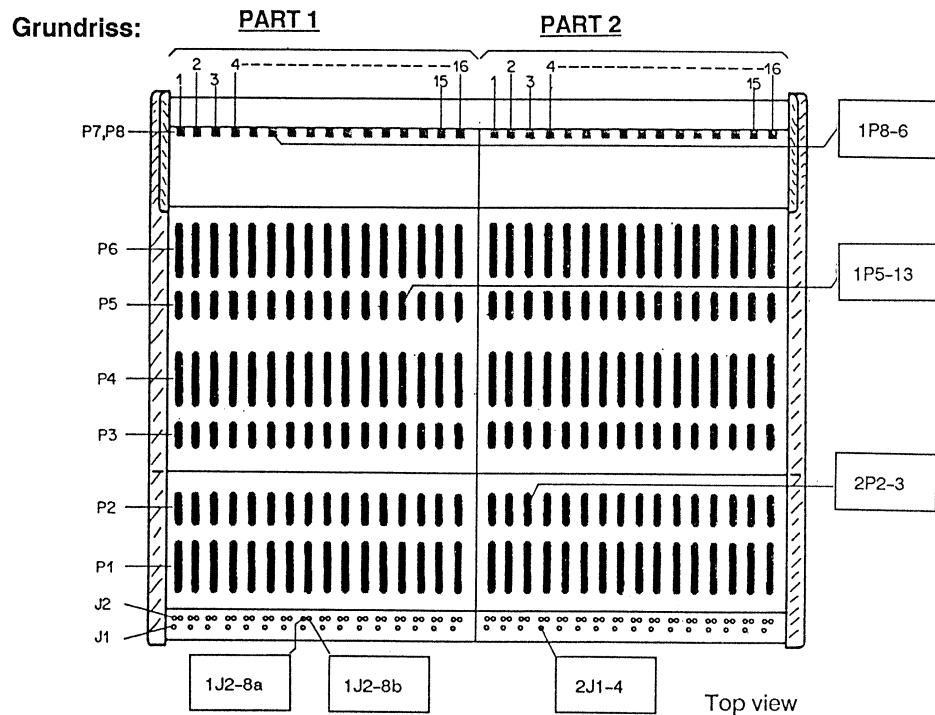

Anschlussfeld: Bezeichnung der Steckerplätze

Die individuelle Auslegung des Anschlussfeldes ist in Kapitel 9 dokumentiert. An dieser Stelle wird lediglich das Prinzip für die Steckerbezeichnung erläutert.

Rückansicht 1:

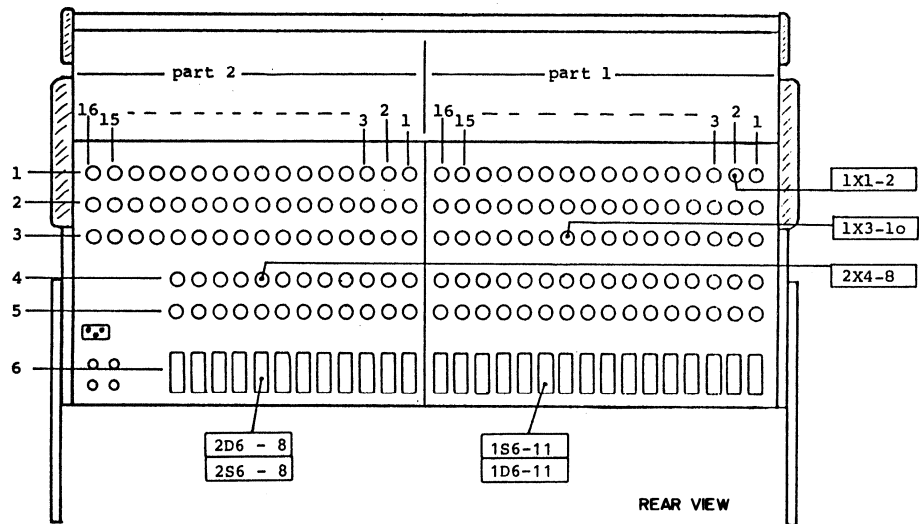

Rückansicht 2:

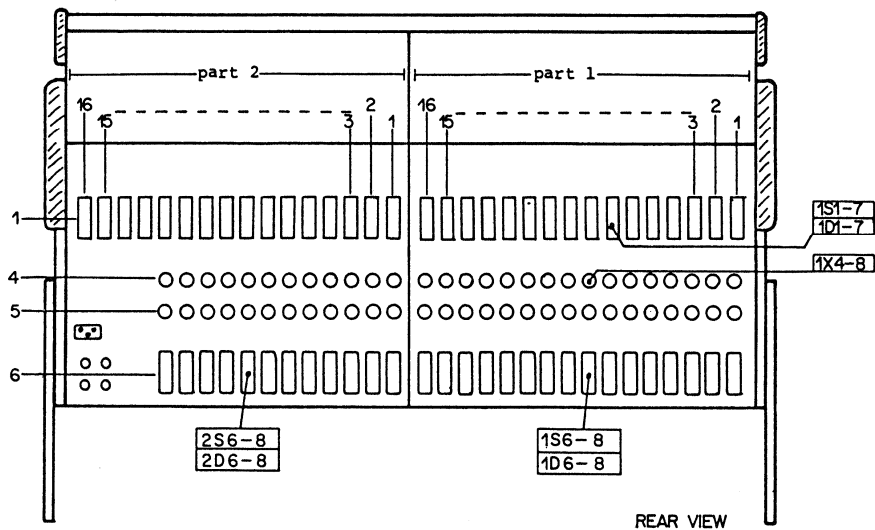

3.3 Verbindungsprint Eingangseinheiten

Die Speisung der verschiedenen Baugruppen sowie der Abgriff der Audio-signale erfolgt über die Eurocard-Stecker an der Basis der Einschubmodule. Die Beschaltung des Input Connection Boards mit dem Stecker P6 ist hier beispielhaft erklärt.

INPUT CONNECTION BOARDS P 6							NOTES
MONO INPUT UNITS A	STEREO HL-INPUT UNITS A	STEREO UNIVERSAL-INPUT UNITS A	MONO INPUT UNITS B	STEREO HL-INPUT UNITS B			
CONNECTION BOARD : 4.940.103 (+12V PH) 4.940.104 (+48V PH)	CONNECTION BOARD : 4.940.125	CONNECTION BOARD : 4.940.123 (+12V PH) 4.940.124 (+48V PH)	CONNECTION BOARD : 4.940.120 (+12V PH) 4.940.124 (+48V PH)	CONNECTION BOARD : 4.940.122			
TAPE INPUT	X LINE 2 INPUT CH 2 (RIGHT)	X LINE INPUT CH 2 (RIGHT)	X TAPE INPUT (OPTIONAL)	O LINE 2 INPUT CH 2 (RIGHT)	X	a / wht 4 b / blu 2 screen / yel 3	
LINE INPUT	X LINE 2 INPUT CH 1 (LEFT)	X LINE INPUT CH 1 (LEFT)	X LINE INPUT	X LINE 2 INPUT CH 4 (LEFT)	X	a / wht 4 b / blu 5 screen / yel 6	
	O OUT IN	X OUT IN	X	O OUT IN	X	P - FILTER INSERT CH 2 (RIGHT) 7 8 9	
	X	O	X	X	O	PHANTOM POWER 40	
	O LINE 1 INPUT CH 2 (RIGHT)	X MIC INPUT CH 2 (RIGHT)	X	O LINE 1 INPUT CH 2 (RIGHT)	X	a / wht 11 b / blu 12 screen / yel 13	
MIC INPUT	X LINE 1 INPUT CH 1 (LEFT)	X MIC INPUT CH 1 (LEFT)	X MIC INPUT	X LINE 1 INPUT CH 1 (LEFT)	X	a / wht 14 b / blu 15 screen / yel 16 17 18 19 20 21 22 23 24 25 26 27 28	
OUT IN	X OUT IN	X OUT IN	X OUT IN	X OUT IN	X	P - FILTER INSERT CH 1 (LEFT) 29 30	
LINE SIGN.	X LINE 1 SIGN.	X LINE SIGN.	X LINE SIGN.	X LINE 1 SIGN.	X	FADER START SIGNAL brn 31	
TAPE SIGN.	X LINE 2 SIGN.	X	O TAPE SIGN. (OPT.)	O LINE 2 SIGN.	X	red 32	

X Δ EQUIPPED
O Δ NOT EQUIPPED

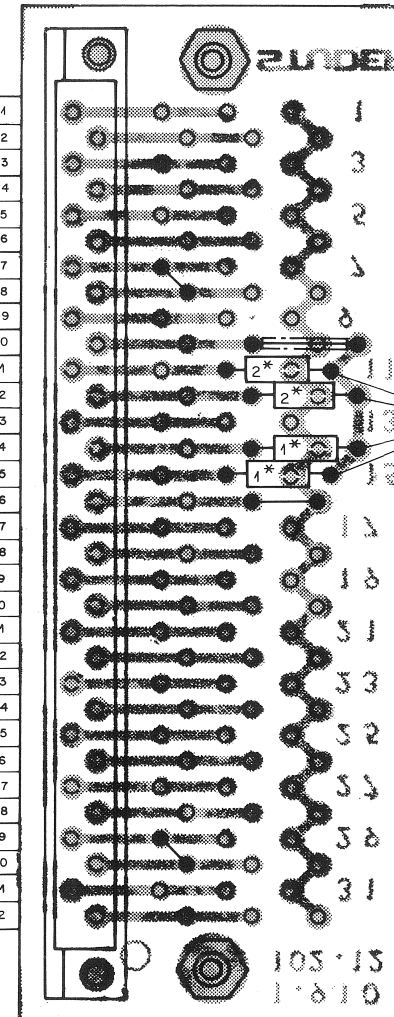

PHANTOM - RESISTORS :
+ 48V = 2 x 6,8k Ω / 0,1% each
+ 24V = 2 x 4,3k Ω / 0,1% each
+ 12V = 2 x 680 Ω / 0,1% each

1* ONLY EQUIPPED FOR :
- MONO INP. UNITS A
- MONO INP. UNITS B

1*+2* ONLY EQUIPPED FOR :
- STEREO UNIVERSAL
INPUT UNITS A

3.4 Sammelschienenanschluss

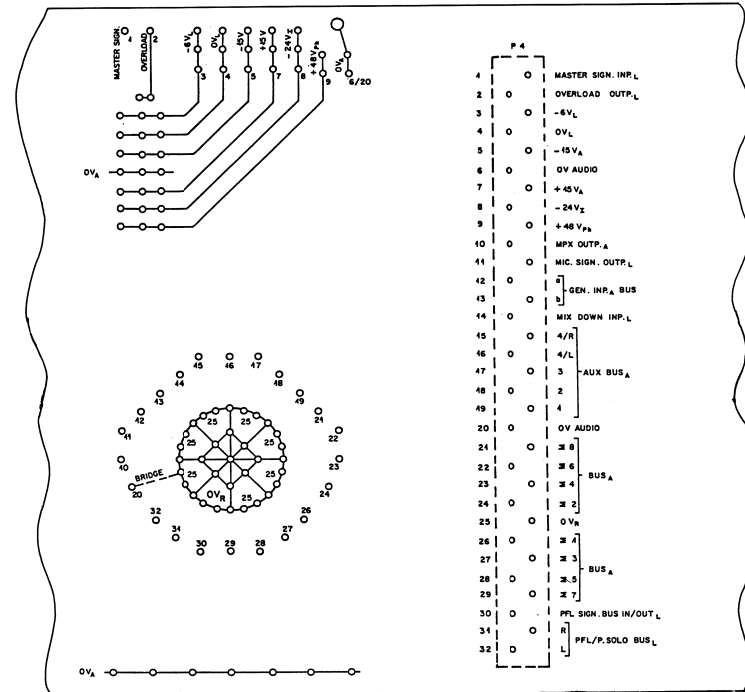

BUS BOARD 1.910.215

. P4 - V .

- ..._A = ANALOG
- ..._L = LOGIC
- ..._R = REFERENCE
- ..._I = INTERNAL
- ..._{Ph} = PHANTOM

3.5 Signalisation

Das Regiepult ist mit zwei Signalisationssystemen ausgerüstet:

- eine optische Studio-Signalisation
- ein Signalisationssystem zur Fernbedienung von Wiedergabegeräten

Studio Signalisation

Bestehend aus einem Signalisationsfeld mit:

- Anzeige "STUDIO ON" (rotes Licht)
- Anzeige für "READY" (grünes Licht)
- Rückmeldung "ON AIR"
- "CALL" Taste für optische Verbindung zwischen Sprecher und Regie.

Steuerlogik: Die "READY"- und "STUDIO ON"-Signale können durch getrennte Tastschalter einzeln eingeschaltet werden, wobei das "STUDIO ON"- Signal erst durchgeschaltet wird, wenn bei einer oder mehreren Eingangseinheiten folgende Bedingungen erfüllt sind:

- Input Selector muss auf MIC geschaltet sein.
- MIC CUT - Funktion darf nicht aktiv sein.
- MUTE inaktiv.
- Kein MIX DOWN Betrieb.
- INPUT FADER muss aufgezogen sein
- Mindestens ein MASTER (SUMME) muss angewählt sein
- Mindestens ein MASTER FADER muss aufgezogen sein.

Die Relaiskontakte für die Signalisation stehen am D-Typ 15 Pin Stecker "SIGNALING STUDIO" im Anschlussfeld zur Verfügung.

Über die individuelle Ausführung der Studiosignalisation gibt das Blockschalbild "Signalisation" im Kapitel 2 Auskunft. Dort ist auch die Position des Steckers "Signaling Studio" angegeben.

Die Studio Signalisation arbeitet ausschliesslich mit -24 Volt und ist bis ca. 500mA belastbar. (Speisung -24Volt im Pult eingebaut)

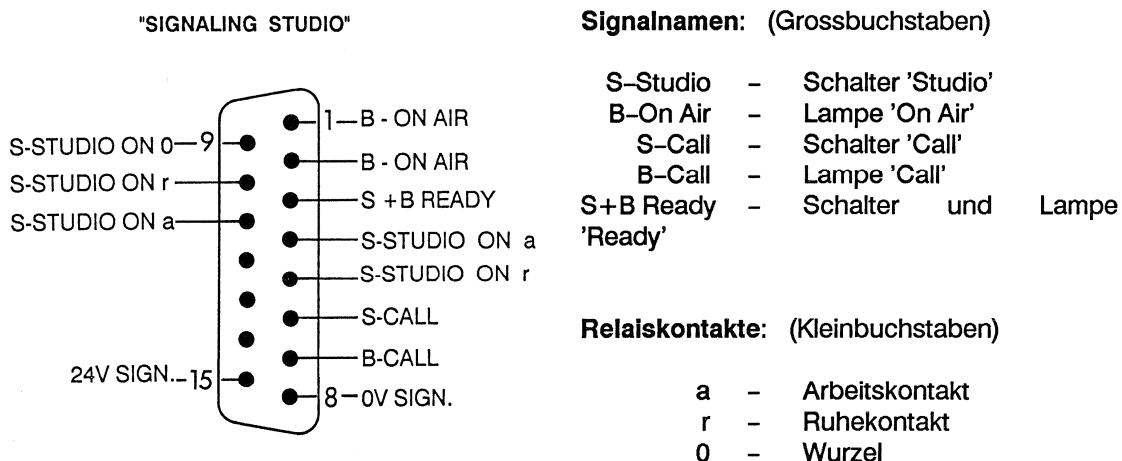

Schaltschema der Studiosignalisation

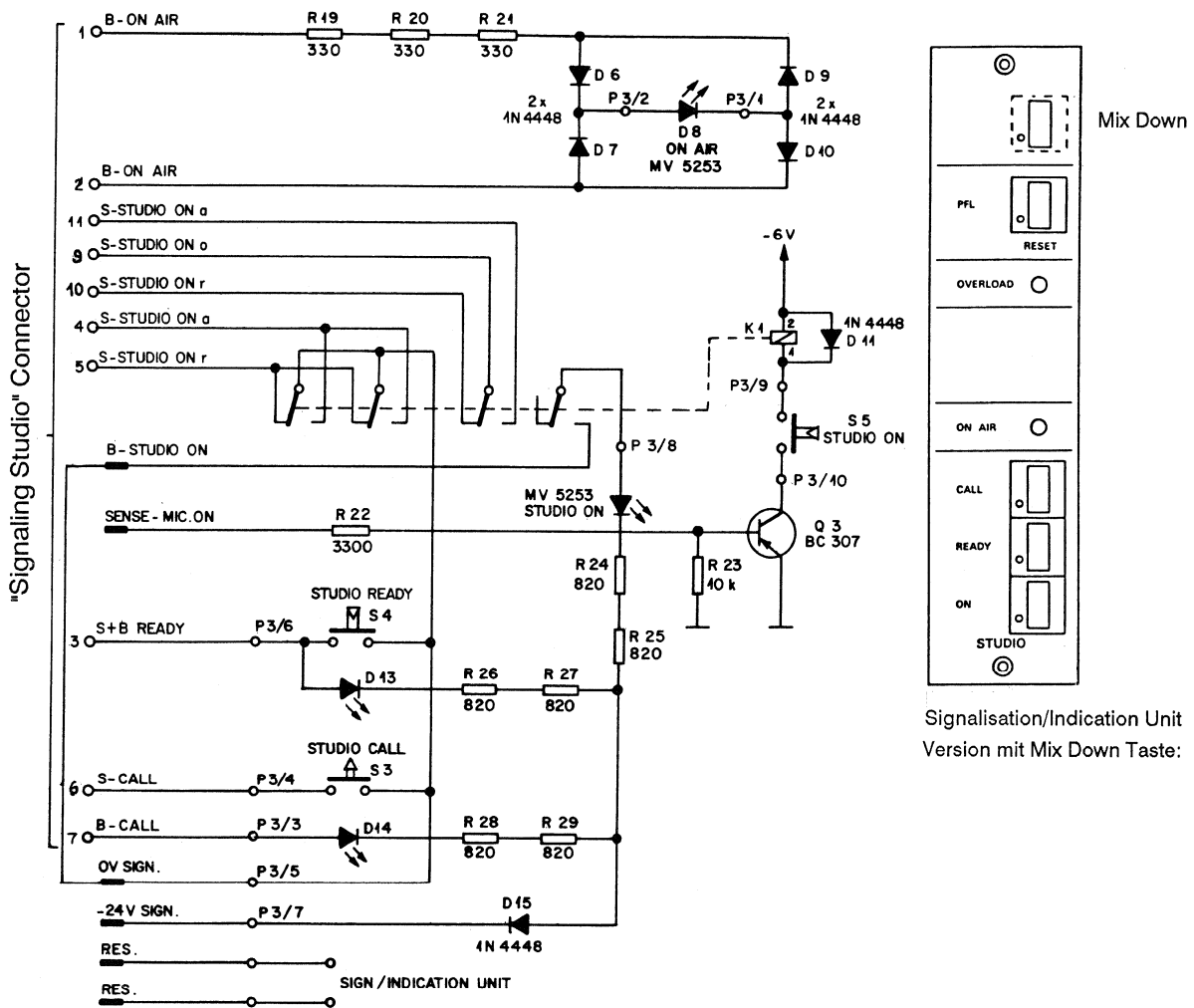

Signalisation/Indication Unit 1.913.140
Version mit Mix Down Taste: 1.913.141

Faderstart Signalisation

An jedem Kanal steht pro Eingang ein separates Fernsteuersignal für Wiedergabegeräte zur Verfügung. Je nach Stellung des Eingangswahlschalters wird einzeln das Zuspieldgerät für den LINE- bzw. den TAPE-Eingang angesteuert. Am Steuerausgang des jeweiligen Inputs liegen dann $-6V$ an, die mit maximal $2,5mA$ belastbar sind.

Da mit dieser Steuerspannung kein Relais direkt angesteuert werden kann, sind in jedem Pult serienmässig alle Steuerleitungen auf die Buchse 'FADER SIGNAL' geführt. In der gleichen Buchse sind auch die Steuerleitungen zu den Faderstartrelais vorhanden. Im zugehörigen Stecker können somit beliebige Faderstartsignale mit Drahtbrücken auf jedes gewünschte Relais (Abspielgerät) geschaltet werden. Der Stecker 'Fader Signal' dient also in der Art eines Jumpers als Programmierstecker.

Wenn in einem speziellen Anwendungsfall direkt die Steuerleitung benutzt werden soll, kann mit folgender Schaltung ein Relais angesteuert werden:

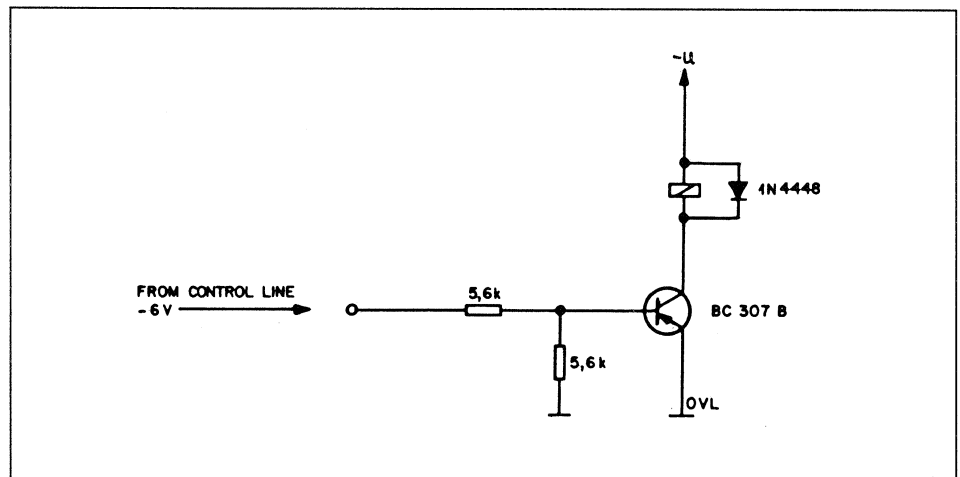

Je nach Pultauslegung steht eine unterschiedliche Anzahl Relais zur Verfügung. Pro Relais-Europakarte 1.915.603 bestehen 9 Schaltmöglichkeiten; 7 Arbeits- und 2 Umschaltkontakte.

- Steuerlogik:** Damit ein Fernsteuersignal durchgeschaltet wird, müssen folgende Bedingungen erfüllt sein:
- INPUT SEL auf 'Tape', wenn Tape auf Relais geschaltet
 - INPUT SEL auf 'Line', wenn Line auf Relais geschaltet
 - falls 'LINE' kein MIX DOWN Betrieb.
 - MUTE darf nicht aktiviert sein
 - INPUT FADER aufgezogen
 - BUS SEL: mindestens 1 MASTER (Summe) muss angewählt sein.
 - Mindestens 1 MASTER FADER muss geöffnet sein.

Blockdiagramm Faderstart Fernsteuerung für 1 Eingangskanal

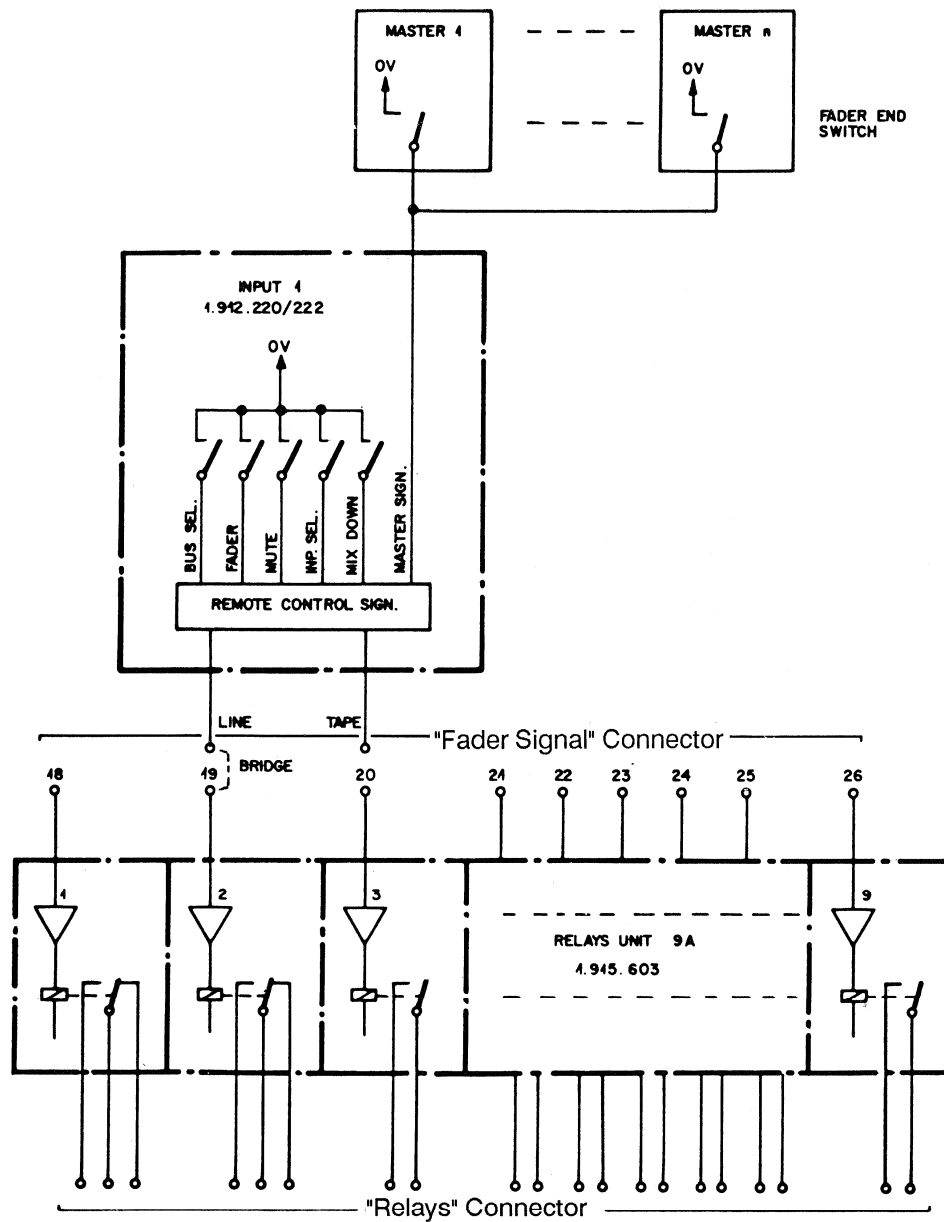

Blockdiagramm Faderstart Fernsteuerung für ganzes System

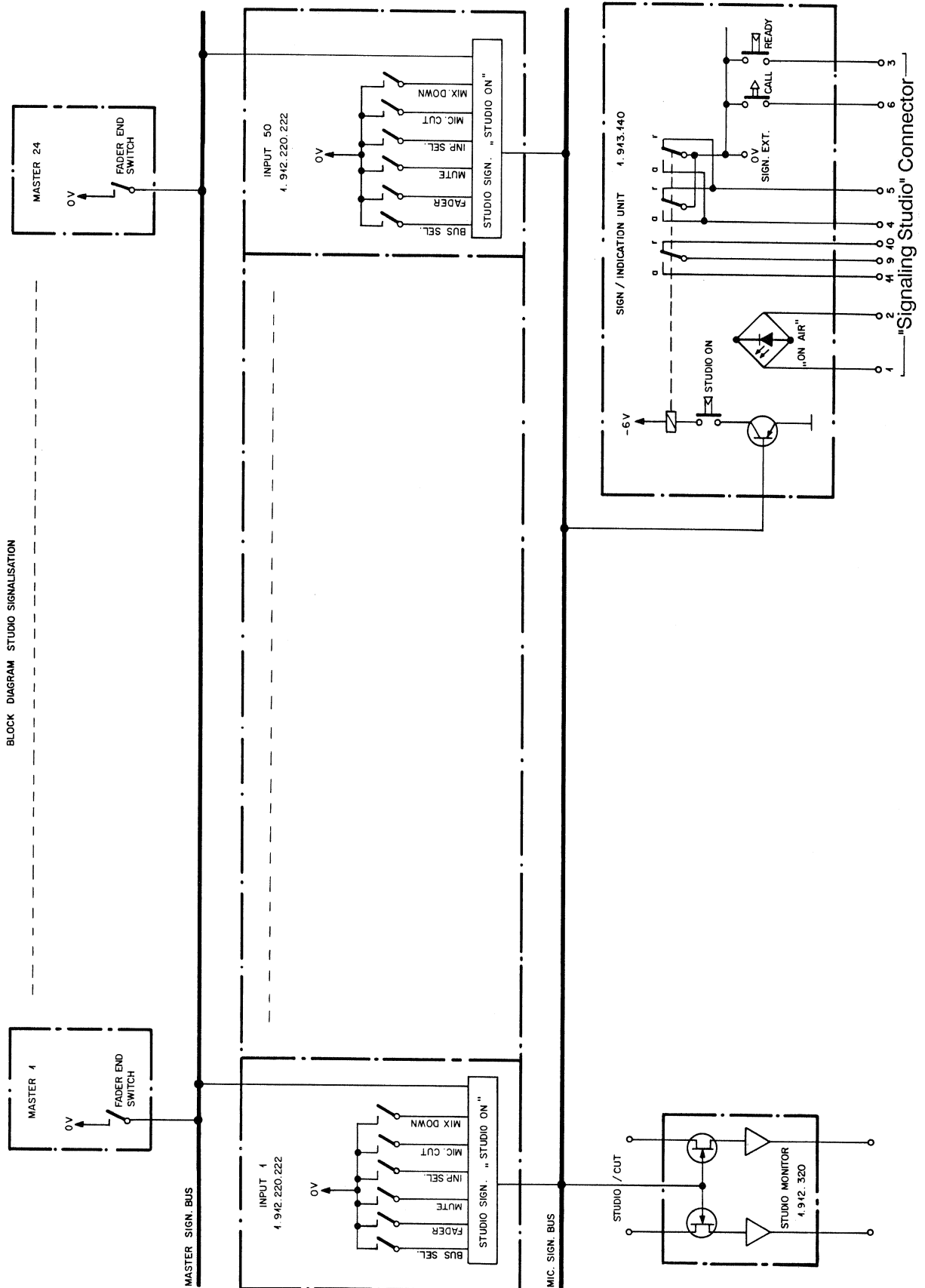

ALLGEMEINES

Beispiel: Mit Input 4 (Tape Input) soll Tape 9 ferngesteuert werden:

Das Faderstartsignal des Tapeeinganges Kanal 4 wird im Stecker 'FADER SIGNAL' auf die Steuerleitung zum Relais K9 verdrahtet. Vorausgesetzt wird natürlich, dass an der Buchse 'RELAYS' eine Fernsteuerverbindung von Relais K9 zum Tape 9 besteht.

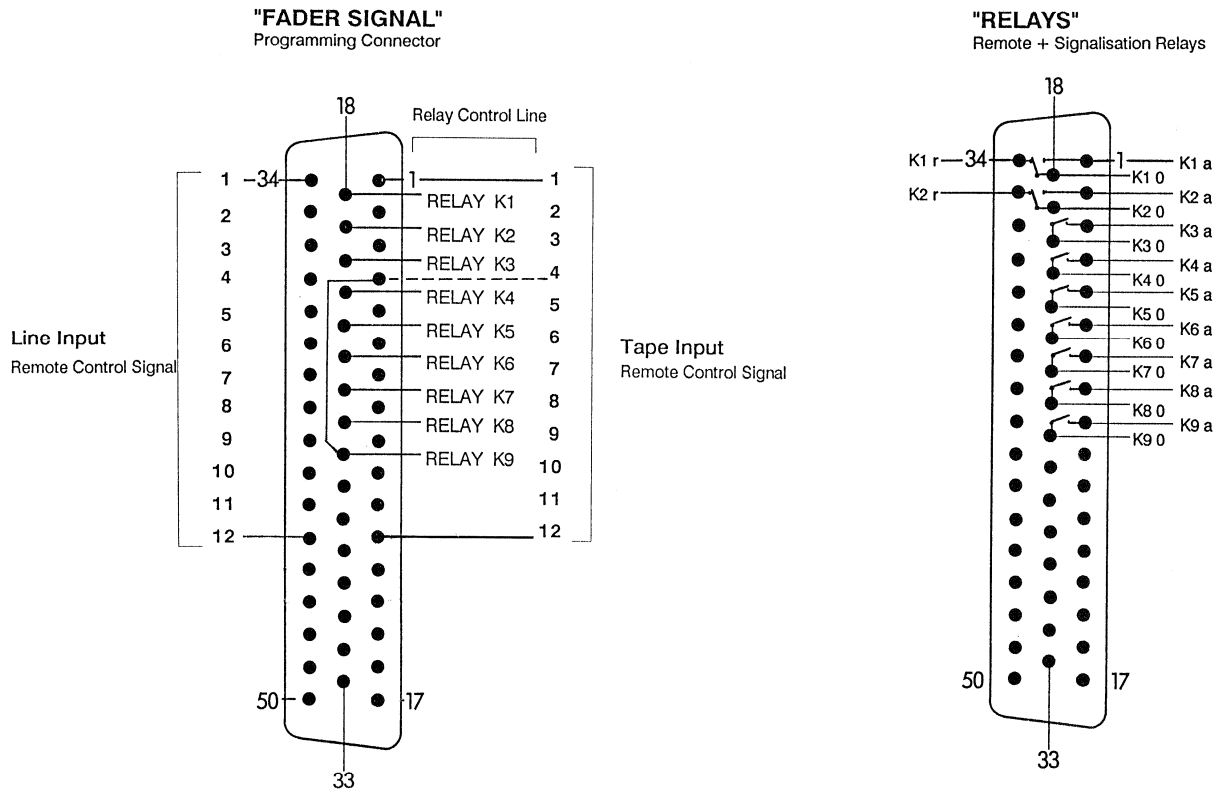

Input 4 (Tape) soll Tape 9 fernsteuern: Verbinde im hier abgebildeten Beispiel Pin 4 des Steckers 'Fader Signal' mit Pin 26. Nun kann der Schaltkontakt von Relais K9 an der Buchse 'Relays' zum Fernsteuern der Maschine benützt werden. (K9 0 - K9 a)

3.6 Masseführung im Blickpunkt

Mit der Neuentwicklung der Serie 900 Mischpulte sind für eine ganze Reihe von Problemen grundsätzlich neue Lösungen gefunden worden. Ein sehr wesentlicher Punkt betrifft die Erzielung bester Werte für das Übersprechen und den Fremdspannungsabstand. Der folgende Beitrag zeigt sowohl die Problematik als auch die fortschrittlichen Lösungswege auf.

Probleme der Masseführung treten in unterschiedlichem Ausmass in allen Audiogeräten auf. Ihre Lösung bedarf einer sorgfältigen Planung. Alle Beteiligten müssen ihren Beitrag dazu leisten: der Ingenieur in der Entwicklung, der Laborant bei der Auslegung der Leiterplatten, der Konstrukteur bei der Suche nach der besten mechanischen Lösung, oder der Mechaniker bei der Montage der Geräte.

Selbst der Anwender muss einige Grundkenntnisse mitbringen, um ein optimales Resultat erzielen zu können.

Die grossen Probleme der Studio-Erdung inkl. der elektrischen Sicherheit könnten ganze Bücher füllen, stehen aber hier nicht zur Diskussion. Der folgende Bericht beschränkt sich auf die interne Masseführung im Regiepult 900.

Die äussere Beschaltung

Beispiel: Ein Signalstrom fliesst durch die Masse vom Eingang zum Ausgang und ist hier als Störung feststellbar.

Grund: Der Wechselstrom i produziert am Kupferwiderstand R_{Cu} der Masseleitung einen Spannungsabfall, der am Ausgang verstärkt als Störung erscheint. Vor allem bei Amateurgeräten mit unsymmetrischen Trennstellen ist dies ein grosses Problem. Durch den Einsatz von symmetrischen Trennstellen (Trafos oder Elektronik) ist dieses Problem bei Profigeräten weitgehend gelöst.

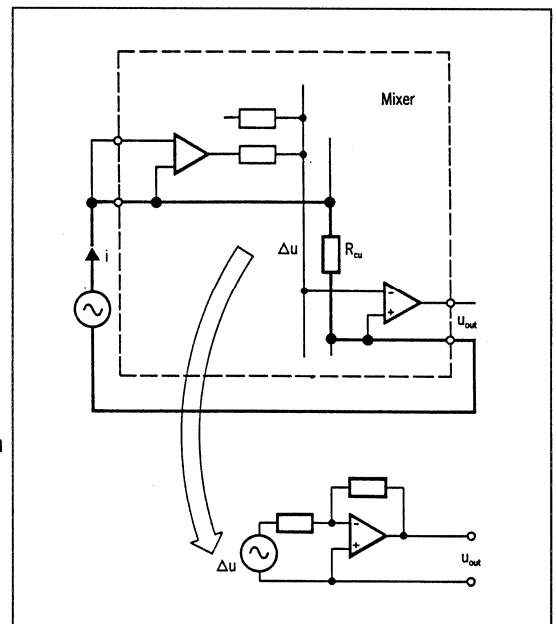

Lösung: Die Masseleitungen der Eingänge sind an der Rückwand zusammengefasst und führen gemeinsam auf die Masse des Netzteils. Anstelle der Einspeisung in den Rückleiter wird der störende Strom jetzt in den Schirmleiter eingespiesen und kann die Übertragung nicht mehr stören.

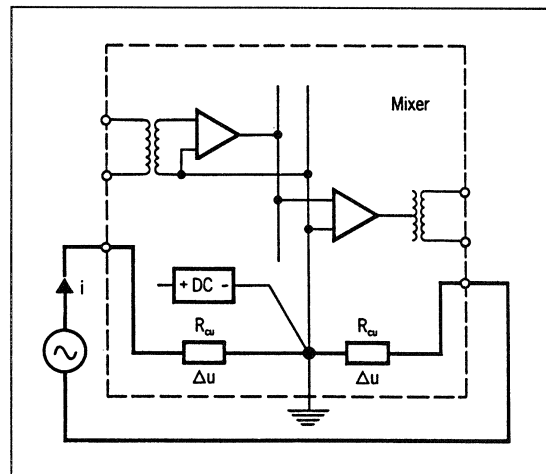

Die interne Masseführung

Das Mischpult ist immer die Hauptschaltzentrale im Tonstudiobereich. Unzählige Audiowege lassen sich schalten. Nicht alle Wege werden mit gleichartigen Signalen durchlaufen. Es bestehen somit recht hohe Anforderungen an das Übersprechen.

Beispiel: Pflichtenheft der ARD:

Panorama Potentiometer	> 70dB
abhängige Wege	> 80dB
unabhängige Wege	> 85dB
verschiedene Programme	> 95dB
Reglerdämpfung	> 100dB

Andere Rundfunkanstalten stellen vergleichbare Forderungen.

Durch mechanische Aufteilung der Kanäle lässt sich das kapazitive Übersprechen beheben. Das ohmsche Übersprechen ist jedoch nur mit einer optimalen Masseführung zu verhindern.

Zur Problemstellung:

Der Eingang 1 ist angesteuert. Die Spannung bildet am Widerstand R einen Strom i . Dieser fließt über die Masse der Sammelschiene zum Netzteil. Die Masseleitung lässt sich darstellen als eine Serieschaltung von Teilwiderständen ΔR_{Cu} .

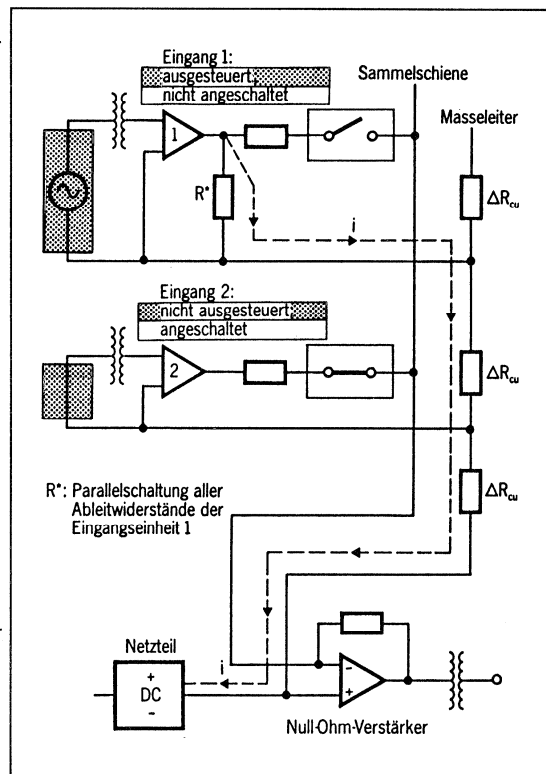

Einfache Anordnung einer Sammelschiene

Der Strom i bildet an ΔR_{Cu} einen Spannungsabfall Δu . Diese Spannung wirkt im aufgeschalteten Kreis 2 als Generator und produziert ein Übersprechen.

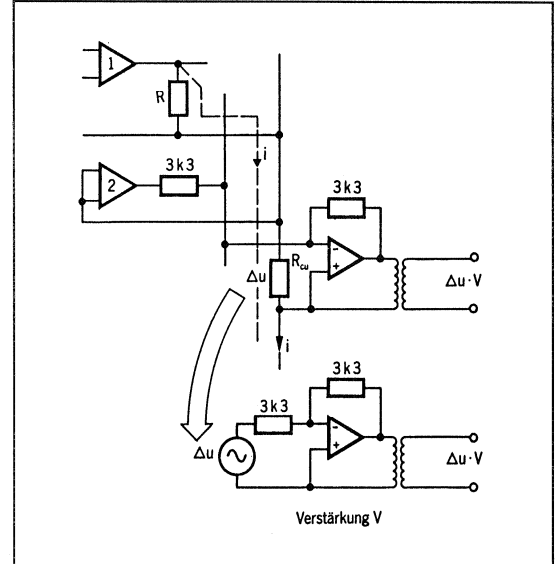

Ohmsches Übersprechen

Mögliche Lösungen:

- Masseschiene mit grossem Querschnitt verwenden
- Einspeisung der Masse in der Mitte der Sammelschiene
- Sternförmige Massenverdrahtung (nicht realisierbar)
- Entkoppelung durch Trafos (nicht mehr zeitgemäss)
- Entkoppelung durch Differentialverstärker

Im Pult 900 wird die letzte Lösung angewendet; diese soll hier noch etwas näher beschrieben werden. Grundlage des Systems bildet der Differentialverstärker.

Die Eingangs- und Ausgangs-Gleichtaktstörungen werden durch die Schaltung auskompensiert. Als Bezugsmasse wird im Pult 900 eine «0V-Referenz»-Leitung eingeführt. Dieser Leiter darf unter keinen Umständen belastet werden.

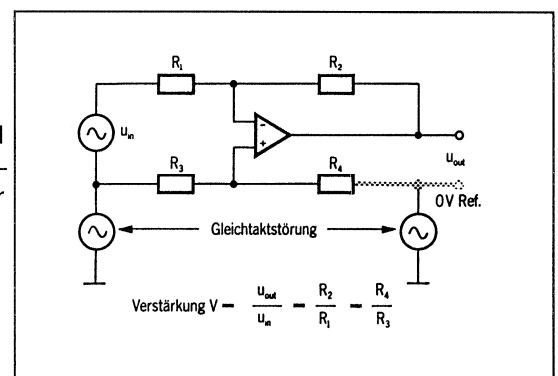

Entkoppelung durch Differentialverstärker

Die Anwendung auf die praktizierte Schaltung zeigt die folgende Abbildung:

ALLGEMEINES

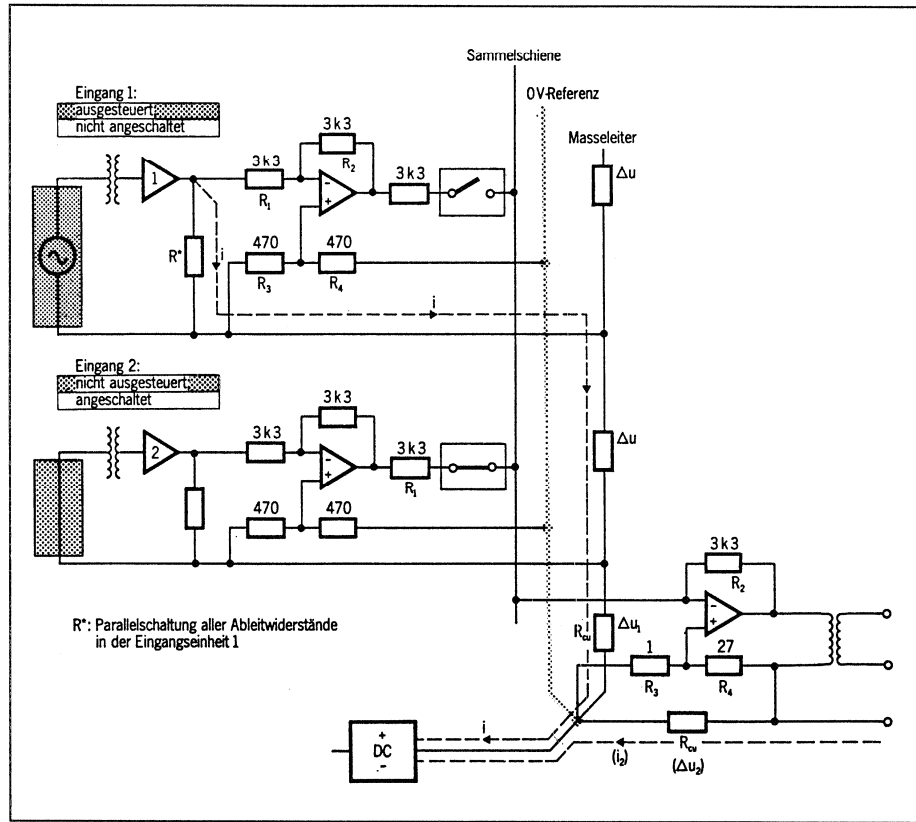

Der Eingang 1 wird wiederum angesteuert und produziert am Widerstand R_{Cu} einen Strom i . Dieser fließt über die Masse der Sammelschiene zum Netzteil. Der Strom i produziert an ΔR_{Cu} eine kleine Spannung Δu_1 .

Der eingebaute Differentialverstärker kompensiert diese Spannung und Δu_1 fällt dadurch weg. Mit dieser Massnahme ist das ohmsche Übersprechen unterdrückt. Um ein gutes Resultat zu erzielen muss im Differentialverstärker die Bedingung $R_2 : R_1 = R_3 : R_4$ möglichst gut erfüllt sein.

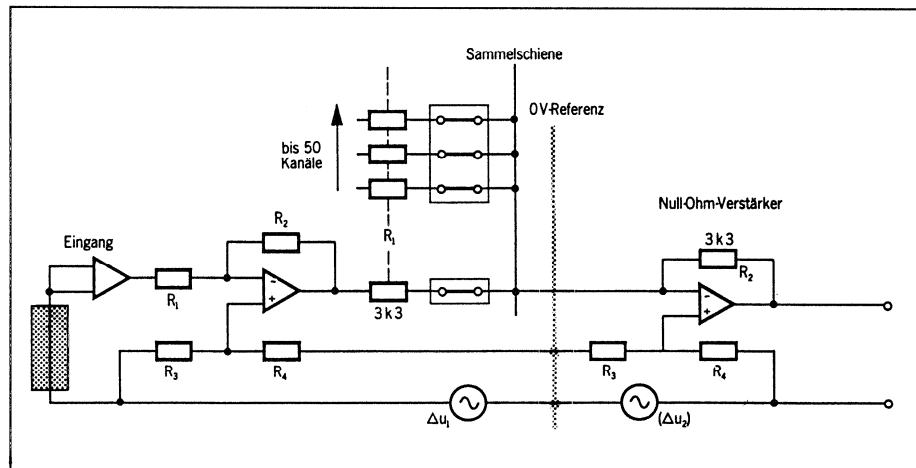

Diese Forderung ist in der Eingangseinheit, im Gegensatz zum Null-Ohm-Verstärker, gut erfüllt. Im Null-Ohm-Verstärker variiert der Eingangswiderstand R_1 zwischen 3k3:1 und 3k3:50, je nach der angewählten Kanalzahl. Trotzdem ergibt sich eine eindeutige Verbesserung für die Unterdrückung der Störsignale.

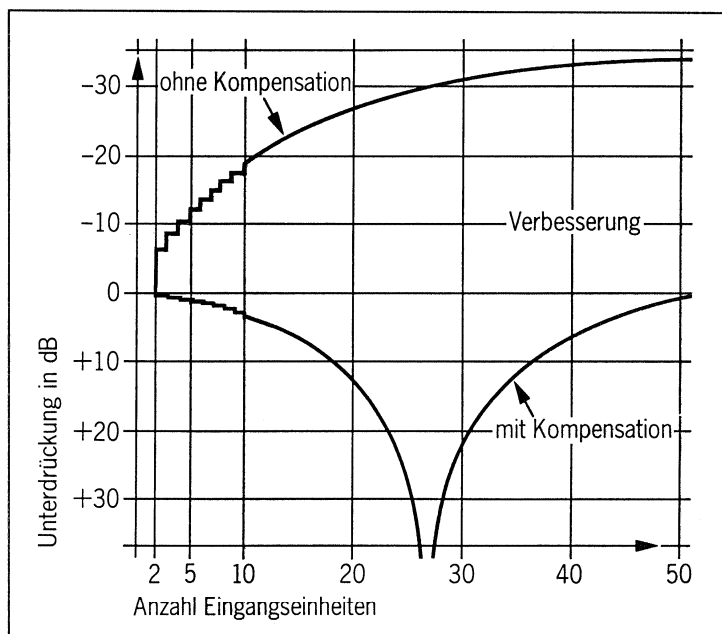

Störsignalunterdrückung in Abhängigkeit von der Kanalzahl.

Differentialverstärker werden im ganzen Mischpult an allen wichtigen Trennstellen eingesetzt. Diese Tatsache sollte beim nachträglichen Einbau von Sonderanfertigungen unbedingt beachtet werden. Durch die konsequente Anwendung dieser fortschrittlichen Technik sind wir in der Lage, auch grösste Regiepulte mit guten Übersprech- und Fremdspannungswerten anzubieten.

ALLGEMEINES

4. Elektrische Daten

Allgemein gilt: ■ Spannungen in dBu beziehen sich immer auf 0,775V.

$$0 \text{ dBu} \cong 0,775 \text{ V}_{\text{eff}}$$

- Die Flachbahnregler der Eingangskanäle und der Summen sind auf 0dB eingestellt.
- Leitungsausgänge sind mit 600Ω abgeschlossen.
- Externe Quellen haben einen Quellenwiderstand von $\leq 200\Omega$.
- Die Angaben gelten im Frequenzbereich von 31,5Hz ... 16kHz.
- Angegebene Pegel sind mit Sinusdauernton gemessen.
(0VU \cong 6dB unter Vollpegel)

4.1 Pegel

Eingänge:	MIC Empfindlichkeit extern in 10dB Schritten grob, und mit Feinregler überlappend stufenlos einstellbar.	-70dBu ... +20dBu
	LINE Empfindlichkeit intern einstellbar. Der externe Feinregler mit Mittenraasterung erlaubt Anpassung um	+6dBu ... +15dBu $\pm 6\text{dB}$
	TAPE Empfindlichkeit intern einstellbar.	+6dBu ... +15dBu
<hr/>		
Einschleifpunkte:	INSERT: Der Pegel (Return) liegt bei	0dBu
<hr/>		
Ausgänge:	Einstellbereich generell Hauptausgang, Hilfsausgänge, Studioausgang, Monitorausgang sind intern einstellbar.	+6dBu ... +15dBu (Last:600Ω)
	Kopfhörer: Monitor und Studio	+10dBu unbelastet

Maximale Pegel

Eingänge:	MIC: +24dBu LINE: +24dBu TAPE: +24dBu INSERT: +20dBu	
<hr/>		
Ausgänge:	Leitung: +24dBu Monitor: +22dBu (30Hz: +18dBu) Studio: +22dBu (30Hz: +18dBu) Insert: +20dBu Kopfhörer: +20dBu (Leerlauf)	
Übersteuerungsreserve:	vor dem Eingangskanalregler (k_{tot} 1%) vor dem Summenregler (k_{tot} 1%)	20dB 20dB

4.2 Pegeldiagramm

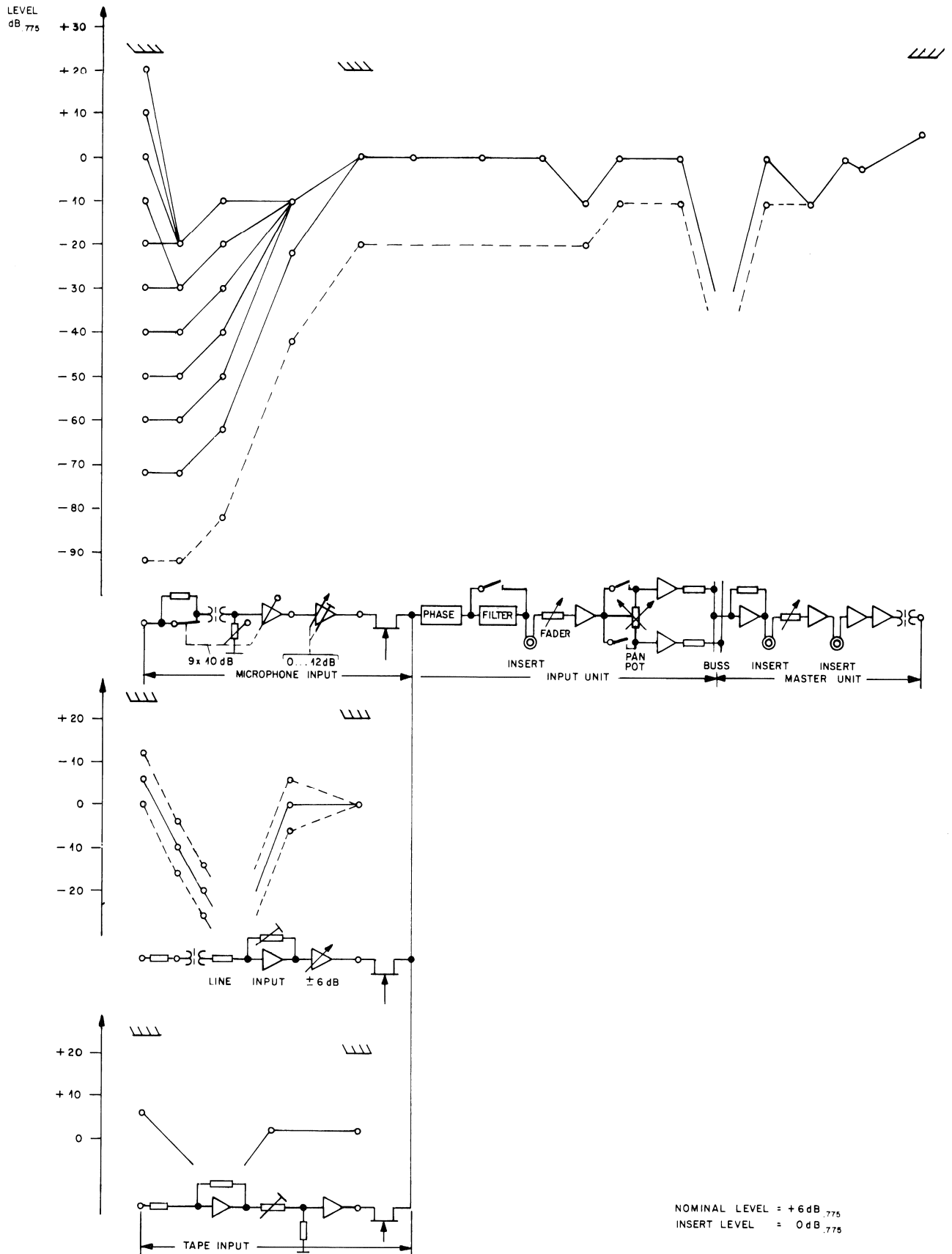

ALLGEMEINES

4.3 Impedanzen

Eingänge:	MIC:	Bereich -70 ... -10dB	\geq	1,2kΩ
		Bereich -10 ... +20dB	\geq	5kΩ
	LINE + TAPE:		\geq	10kΩ
	INSERT:		\approx	5kΩ
Ausgänge:	Hauptausgang, Hilfsausgang, Studioausgang und Monitorausgang generell			\leq 50Ω
	Kopfhörerausgang:			\approx 135Ω
	INSERT:			\leq 50Ω
	Beschreibung:	MIC:	symmetrisch, erdfrei, Quelle	\leq
LINE:		symmetrisch, erdfrei, Quelle	\leq	200Ω
TAPE:		symmetrisch, Quelle	\leq	200Ω
INSERT:		unsymmetrisch, Quelle	\leq	200Ω
	Leitungsausgänge:	symmetrisch, erdfrei, Last	\geq	200Ω
	Studioausgang:	symmetrisch, erdfrei, Last	\geq	600Ω
	Monitorausgang:	symmetrisch, erdfrei, Last	\geq	600Ω
	Insertausgang:	unsymmetrisch, Last	\geq	2kΩ
	Kopfhörerausgang:	unsymm. empfohlene Last	\geq	200Ω

4.4 Frequenzgänge mit Eingangseinheiten Mono "A"

	Filter ausgeschaltet; Toleranz im Bereich von 31,5Hz ...16kHz	+0,5dB / -1dB
Filter:	Trittschallfilter 12dB/Oktave 3dB Punkt einstellbar von	30Hz ...330Hz
	Höhenfilter 12dB/Oktave 3dB Punkt einstellbar von Ausserhalb des Audiobereiches kontinuierlich abfallend mit 12dB/Oktave	700Hz ...20kHz
Equalizer:	HF Höhenregler "Shelfing" Einsatzfrequenz einstellbar	± 15dB 700Hz ...15kHz
	HF Höhenregler "Bell" Mittenfrequenz einstellbar	± 15dB 700Hz ...15kHz (Güte Q \approx 1)
	LF Tiefenregler "Shelfing" Einsatzfrequenz einstellbar	± 15dB 30Hz ...600Hz
	LF Tiefenregler "Bell" Mittenfrequenz einstellbar	± 15dB 30Hz ...600Hz (Güte Q \approx 1)

HMF Präsenzfilter "Bell"	$\pm 15\text{dB}$
Mittenfrequenz einstellbar	400Hz ... 7kHz
Güte 'schmal': $Q \approx 3$	(bei max. Anhebung)
Güte 'breit': $Q \approx 1$	(bei max. Anhebung)

LMF Präsenzfilter "Bell"	$\pm 15\text{dB}$
Mittenfrequenz einstellbar	120Hz ... 2kHz
Güte 'schmal': $Q \approx 3$	(bei max. Anhebung)
Güte 'breit': $Q \approx 1$	(bei max. Anhebung)

4.5 Fremdspannungen

Die Fremdspannungen sind Effektivwerte mit einer äquivalenten Rauschbandbreite von 30Hz ...23kHz (Siemens U2033 oder gleichwertiges Instrument).

Rauschzahl F des Mikrofoneingangs: **F $\leq 4\text{dB}$**
(Quellenimpedanz = 200 Ω)

Fremdspannungsabstand am Summenausgang
(Summenregler geschlossen) **> 100dB**

Einkanalige Anordnung:
Eingangs- und Summenregler 0dB; LINE-Eingang; Verstärkung Ein-/Ausgang = 1;
ohne Equalizer **> 98dB**
mit Equalizer (linear) **> 90dB**

12-kanalige Anordnung:
Eingangs- und Summenregler 0dB; LINE-Eingang; Verstärkung Ein-/Ausgang = 1;
ohne Equalizer **> 90dB**
mit Equalizer (linear) **> 82dB**

24-kanalige Anordnung:
Eingangs- und Summenregler 0dB; LINE-Eingang; Verstärkung Ein-/Ausgang = 1;
ohne Equalizer **> 87dB**
mit Equalizer (linear) **> 79dB**

4.6 Klirrfaktor und Übersprechen

Klirrfaktor:	Für Leitungspegel im Frequenzbereich	$\leq 0,1\%$
Übersprechen:	Übersprechen von Summe auf Summe	> 85dB

4.7 Stromversorgung

Der Netzbetrieb ist für folgende Netzspannungen umschaltbar:
110V, 120V, 140V, 200V, 240V AC $\pm 10\%$

Interne Betriebsspannungen:	+15V	Audio
	-15V	Audio
	-6V	Logik
	-24V	Logik, Steuerung
	24V	Signalisation
	48V	Phantomspannung

SECTION 1: General

1.	General view of the audio console	
1.1	General arrangement drawing.....	1
1.2	List of all plug-in modules.....	3
2.	Dimensions	
2.1	Chassis versions.....	5
2.2	Section drawing	7
2.3	Dimensions of the plug-in locations.....	9
3.	Layout and designations	
3.1	Designation of the slots.....	10
3.2	Connector layout and designations	10
3.3	Connection board, input units	13
3.4	Bus connection	14
3.5	Signalization	15
3.6	A close-up of the chassis ground system	21
4.	Electrical specification	
4.1	Levels.....	26
4.2	Level diagram.....	27
4.3	Impedances.....	28
4.4	Frequency response.....	28
4.5	Noise weighted	29
4.6	Distortion and crosstalk.....	29
4.7	Power supply.....	29

2. Dimensions

2.1 Chassis versions

The console chassis is available in two basic versions for 3 or 4 module sections. The individual console size is achieved with widths for 12 or 16 module sections. A chassis for 12 modules also accommodates 19" standard units of different sizes.

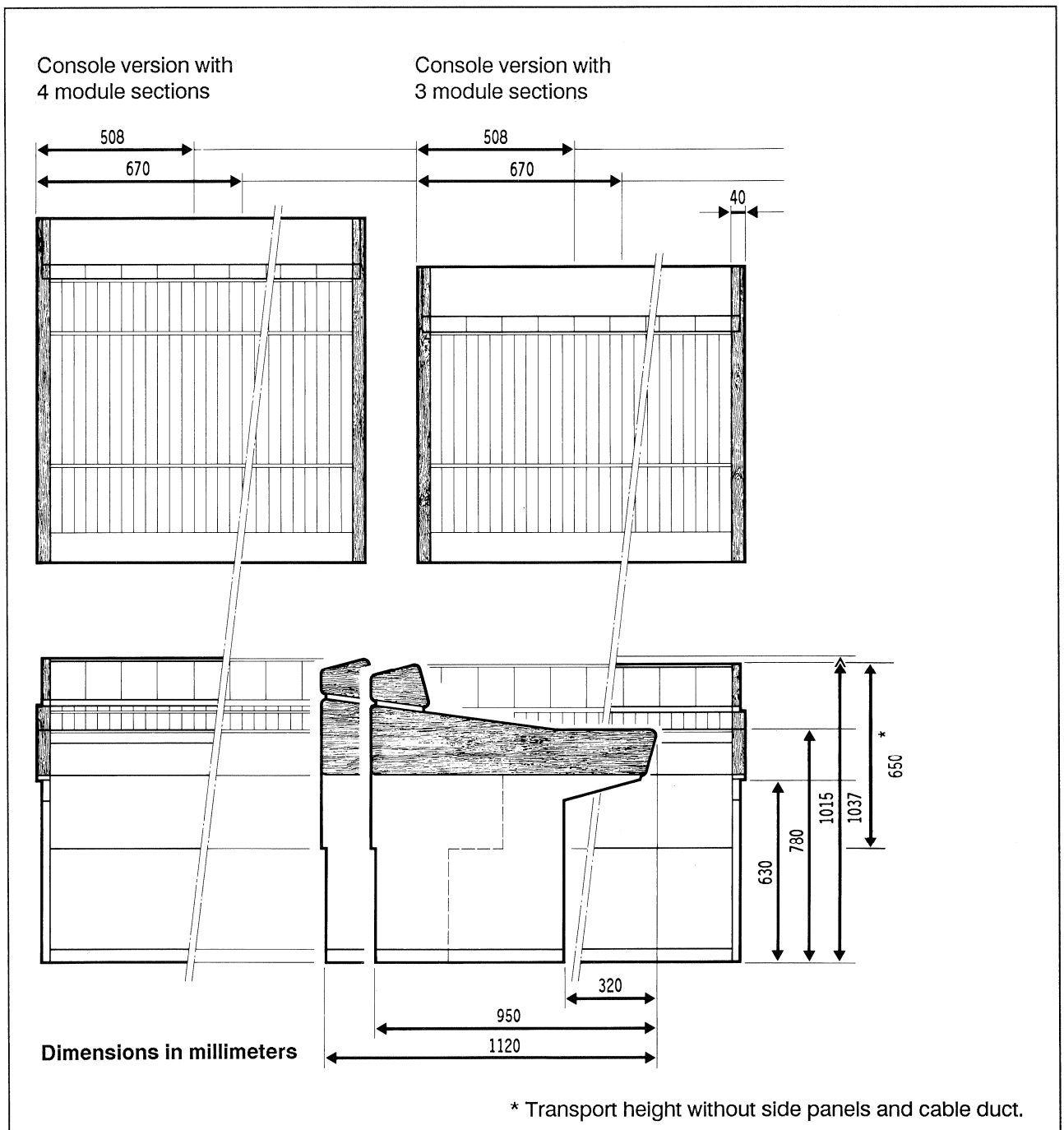
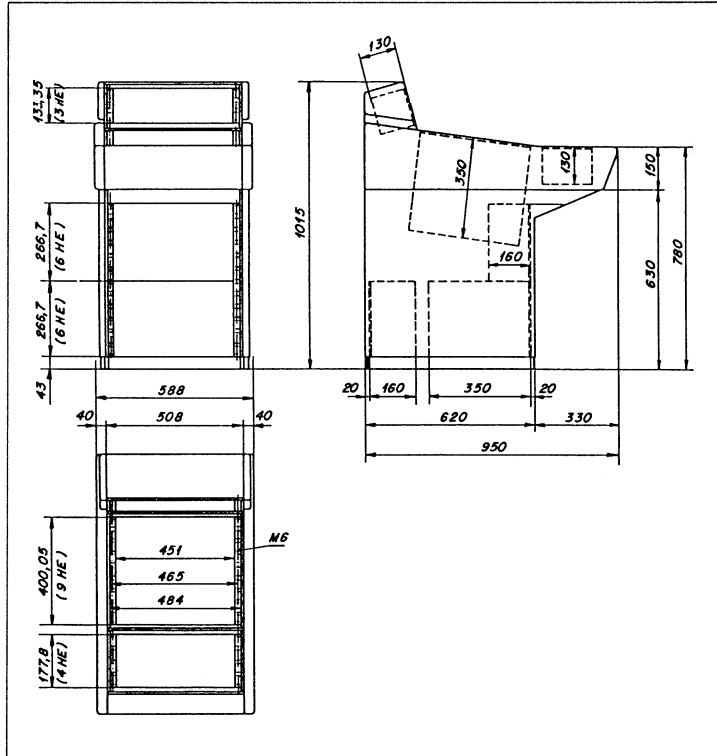

Fig. 1 Dimension drawing of the two chassis widths for the two basic versions with 3 and 4 module sections respectively.

GENERAL

19" Chassis: This chassis corresponds to the basic unit for 12 modules but accommodates 19" standard equipment.



2.2 Section drawing

The sectional view illustrates the console version with 3 module sections. An additional routing section is located between the input panel and the meter panel and has the same dimensions as the meter panel.

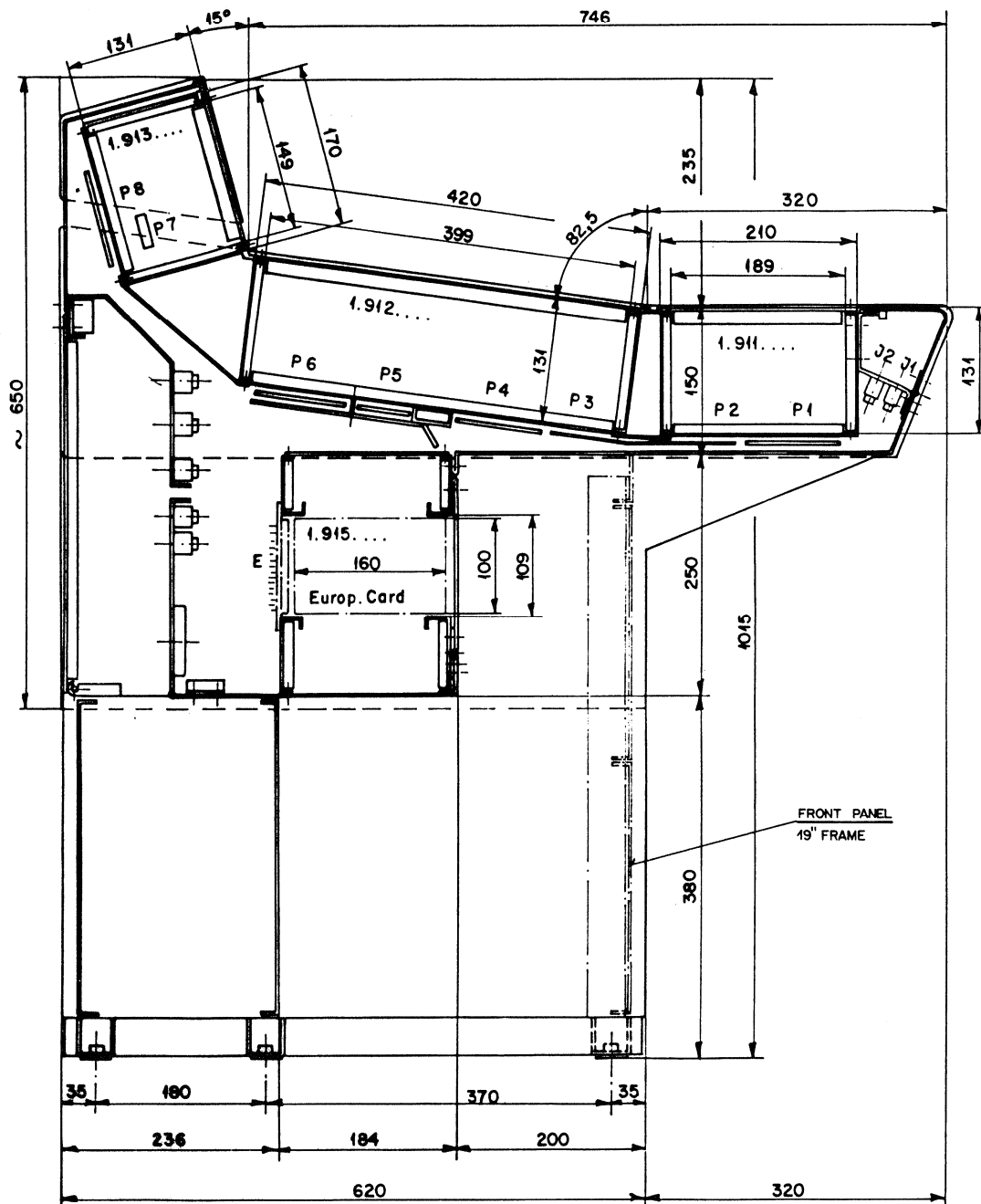

- Connectors:
- J1/J2 → Insert field (Jack)
 - P1 → Fader Input and Output
 - P2/P3 → Interconnection fader - Input unit
 - P4(P8) → Mains bus
 - P5 → Intercom
 - P6 → Inputs
 - P7 → Meter connection
 - X/D/S → Input/Output connection panel
 - E → Eurocards (voltage stabilizer, line amplifier etc.)
- Dimensions in millimeters

2.3 Dimensions of the plug-in locations

Again the mixing console version with 3 module sections is illustrated. A 4th section for the expanded routing has the same dimensions as the meter panel.

Fader section 1.911.*

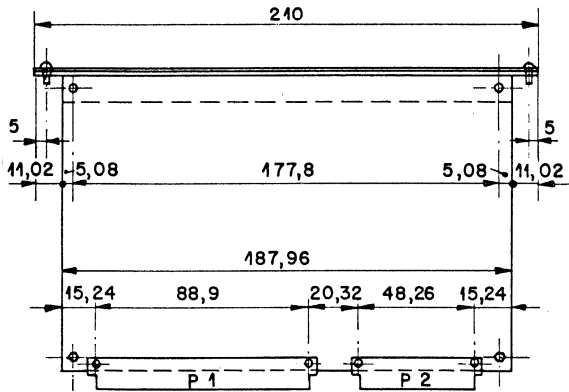

Input section 1.912.*

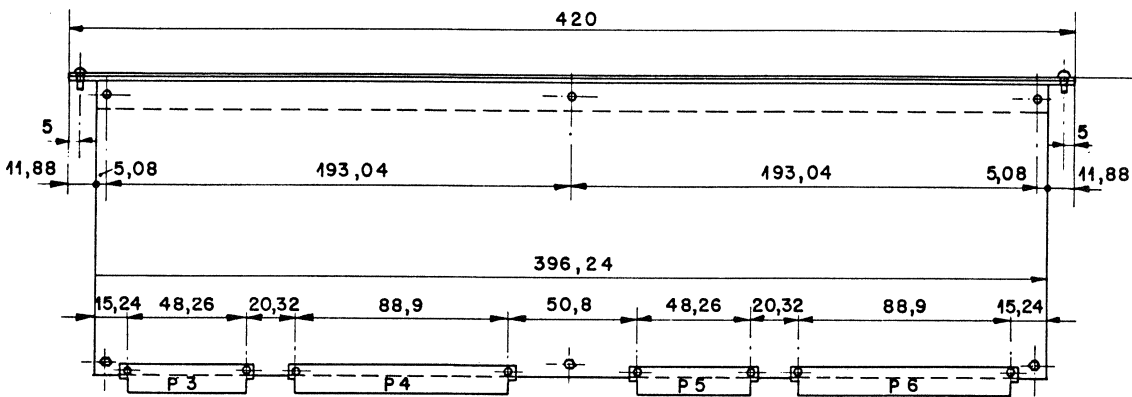

Meter panel 1.913.*

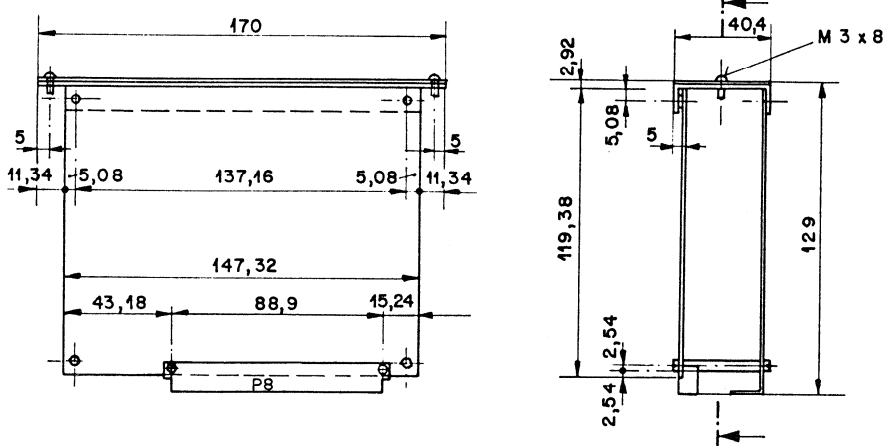

3. Layout and designations

The modular design of the STUDER series 900 mixing consoles permits a layout that is suited to the individual application. After the installation has been completed, the plug-in modules can only be relocated within certain restrictions. The connector panel and the wiring are custom designed for each unit and are documented in Sections 2, 9 and 10 of the manual. As an aid for clarifying the structure and function of the mixing console some basic principles are explained below.

3.1 Designation of the slots

Four to 5 slots are available on a plug-in row (corresponds to one channel). The corresponding modules are numbered with the following starting digits:

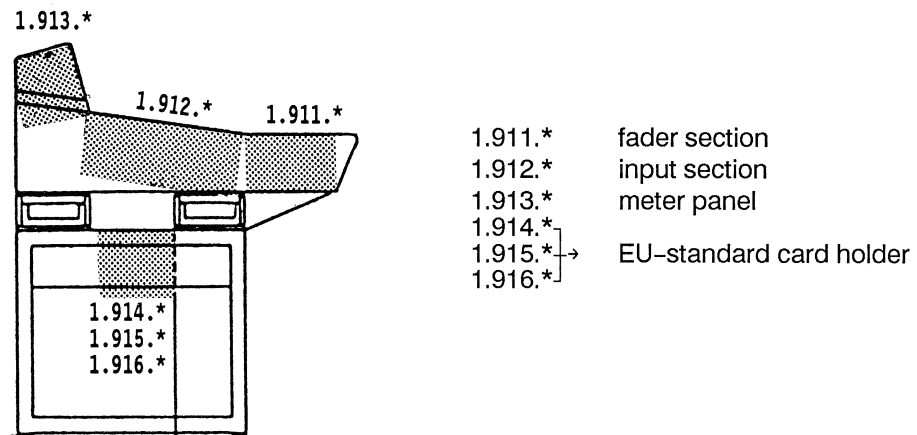

The EU circuit boards are identified with the starting digits 1.915.* and 1.916.*. The STUDER modular sub cards (1.914.*) can be combined on an EU-standard mounting board and also be installed in the EU-standard card holder.

3.2 Connector layout and designations

All connectors of the mixing console carry a designation that identifies the location and the connector type. The designation of a connector consists of four digits that have the following meaning:

1st digit:	Number of the console chassis ¹⁾
2nd digit:	Abbreviation for the connector type (see table)
3rd digit:	Vertical position ²⁾
4th digit:	Horizontal position ¹⁾

¹⁾ Numbering from left to right

²⁾ Top of console: Numbering from front to back
Rear of console: Numbering from top to bottom

Abbreviations for connector type:

P1 / P4 / P6 / P8	32 pin EU-card connector	DIN 41612
P2 / P3 / P5	16 pin EU-card connector	DIN 41612
E	32 / 64 pin EU-card connector	DIN 41612
P7	10 / 16 / 26 pin connector	DIN 41651/MIL
J	Stereo Jack, Ø 6,3mm	
X	XLR connector	
S	Siemens multipin connector	
D	D type multipin connector	

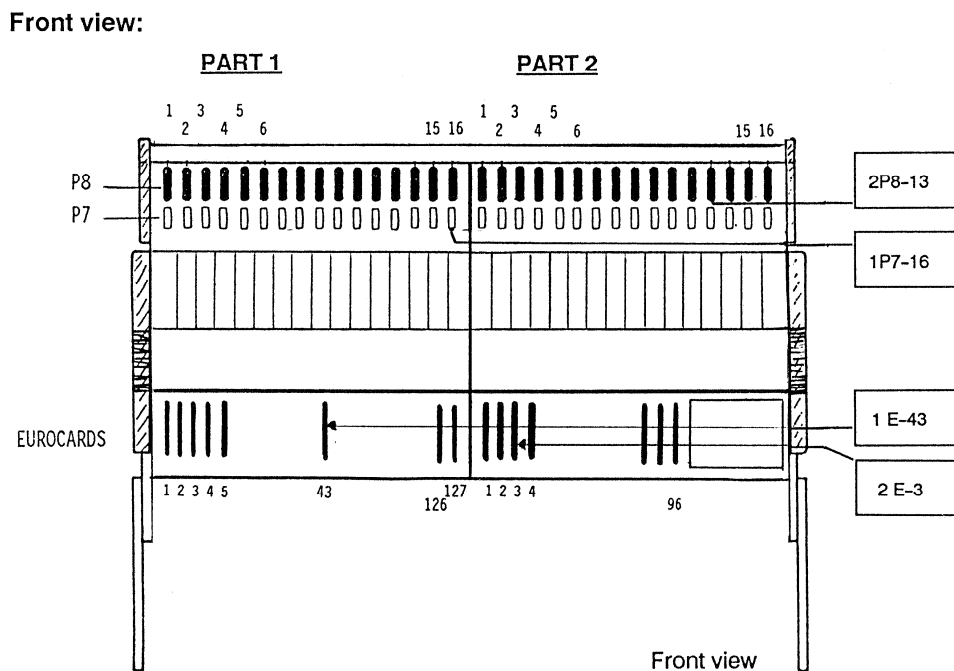
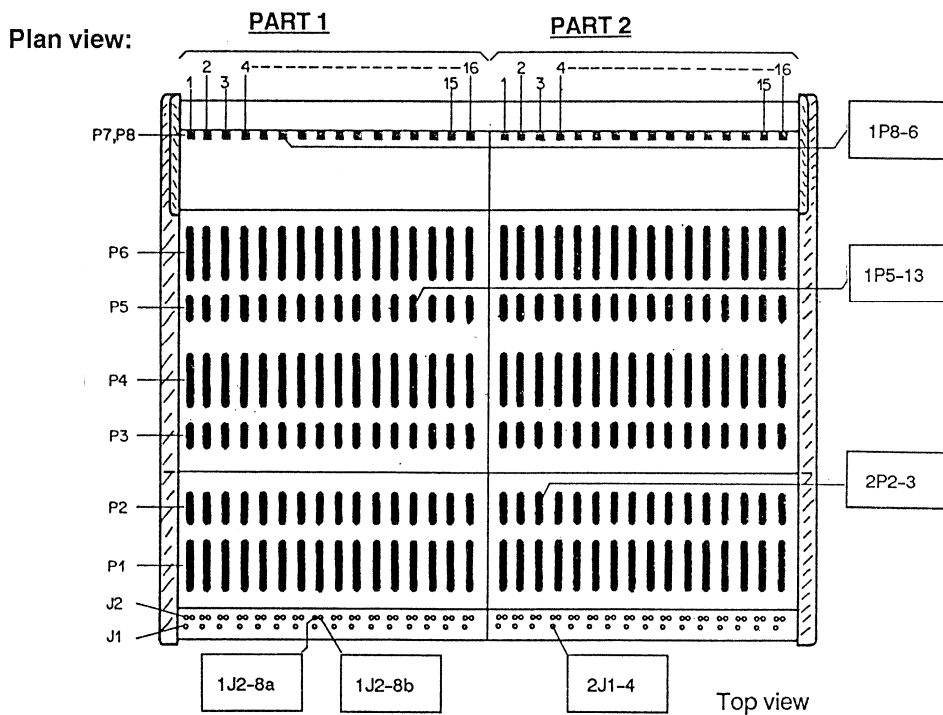

Connector panel: Designation of the connector locations

The individual layout of the connector panel is documented in Section 9. This Section of the manual only explains the principle of the connector designations.

Rear view 1:

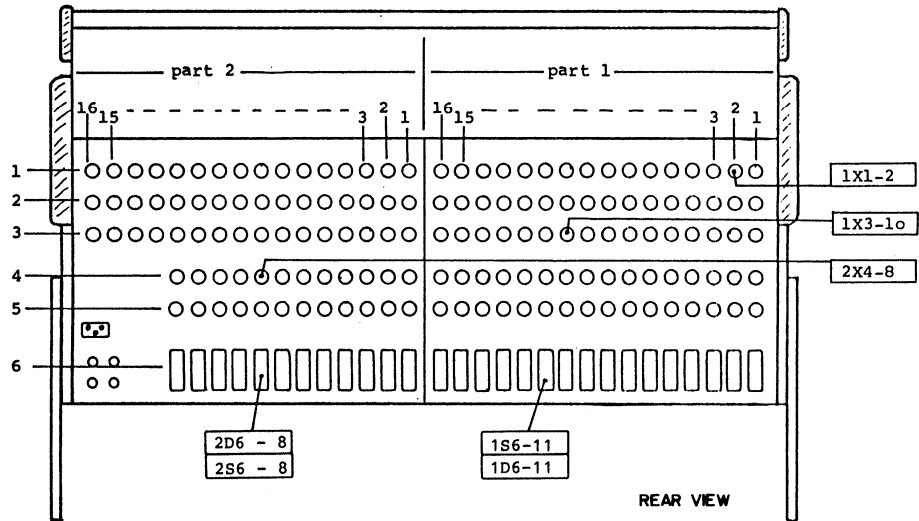

Rear view 2:

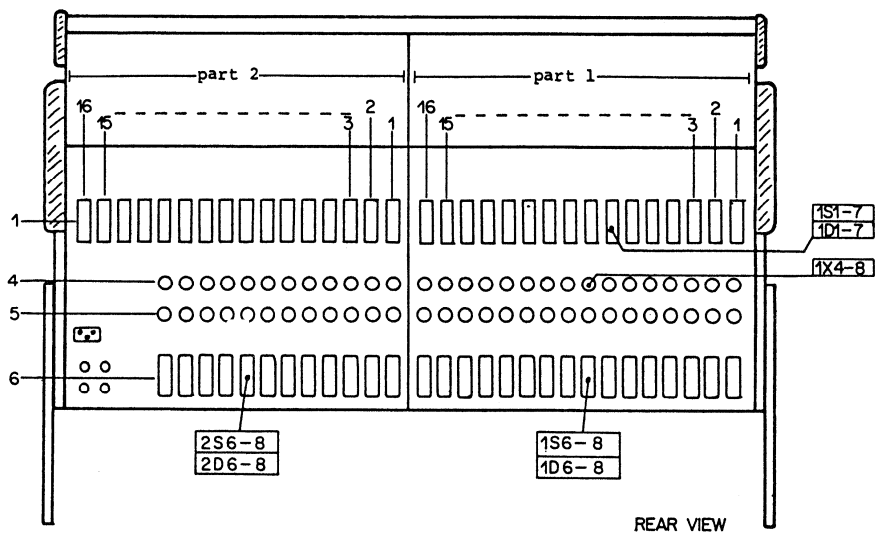

3.3 Connection board, input units

EU-standard connectors at the base of the plug-in modules are used for supplying the various assemblies and for tapping the audio signals. The input connection board with connector P6 is explained here as a typical example.

INPUT CONNECTION BOARDS P 6										
MONO INPUT UNITS A	STEREO HL-INPUT UNITS A		STEREO UNIVERSAL-INPUT UNITS A	MONO INPUT UNITS B	STEREO HL-INPUT UNITS B		NOTES			
CONNECTION BOARD : 4.940.103 (+12V PH) 4.940.104 (+48V PH)	CONNECTION BOARD : 4.940.125		CONNECTION BOARD : 4.940.123 (+12V PH) 4.940.124 (+48V PH)	CONNECTION BOARD : 4.940.120 (+12V PH) 4.940.124 (+48V PH)	CONNECTION BOARD : 4.940.122					
TAPE INPUT	X	LINE 2 INPUT CH 2 (RIGHT)	X	LINE INPUT CH 2 (RIGHT)	X	TAPE INPUT (OPTIONAL)	O	LINE 2 INPUT CH 2 (RIGHT)	X	a / wht 4 b / blu 2 screen / yel 3
LINE INPUT	X	LINE 2 INPUT CH 1 (LEFT)	X	LINE INPUT CH 1 (LEFT)	X	LINE INPUT	X	LINE 2 INPUT CH 1 (LEFT)	X	a / wht 4 b / blu 5 screen / yel 6
	O	OUT IN	X	OUT IN	X		O	OUT IN	X	P - FILTER INSERT CH 2 (RIGHT) 7 8
	X		O		X		X		O	PHANTOM POWER 10
	O	LINE 4 INPUT CH 2 (RIGHT)	X	MIC INPUT CH 2 (RIGHT)	X		O	LINE 4 INPUT CH 2 (RIGHT)	X	a / wht 11 b / blu 12 screen / yel 13
MIC INPUT	X	LINE 4 INPUT CH 1 (LEFT)	X	MIC INPUT CH 1 (LEFT)	X	MIC INPUT	X	LINE 4 INPUT CH 1 (LEFT)	X	a / wht 14 b / blu 15 screen / yel 16
										17 18 19 20 21 22 23 24 25 26 27 28
OUT IN	X	OUT IN	X	OUT IN	X	OUT IN	X	OUT IN	X	P - FILTER INSERT CH 1 (LEFT) 29 30
LINE SIGN. TAPE SIGN.	X	LINE 4 SIGN. LINE 2 SIGN.	X	LINE SIGN. TAPE SIGN.(OPT.)	X	LINE SIGN. TAPE SIGN.(OPT.)	X	LINE 4 SIGN. LINE 2 SIGN.	X	FADER START SIGNAL brn 34 red 32

X Δ EQUIPPED
O Δ NOT EQUIPPED

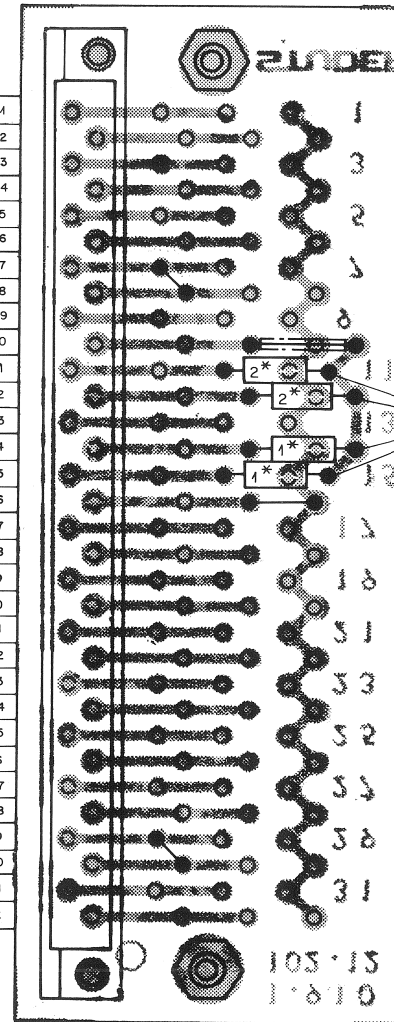

PHANTOM - RESISTORS :
+ 48 V = 2 x 6,8 k Ω / 0,1% each
+ 24 V = 2 x 4,3 k Ω / 0,1% each
+ 12 V = 2 x 680 Ω / 0,1% each

4* ONLY EQUIPPED FOR :
- MONO INP. UNITS A
- MONO INP. UNITS B

4*+2* ONLY EQUIPPED FOR :
- STEREO UNIVERSAL
INPUT UNITS A

3.4 Bus connection

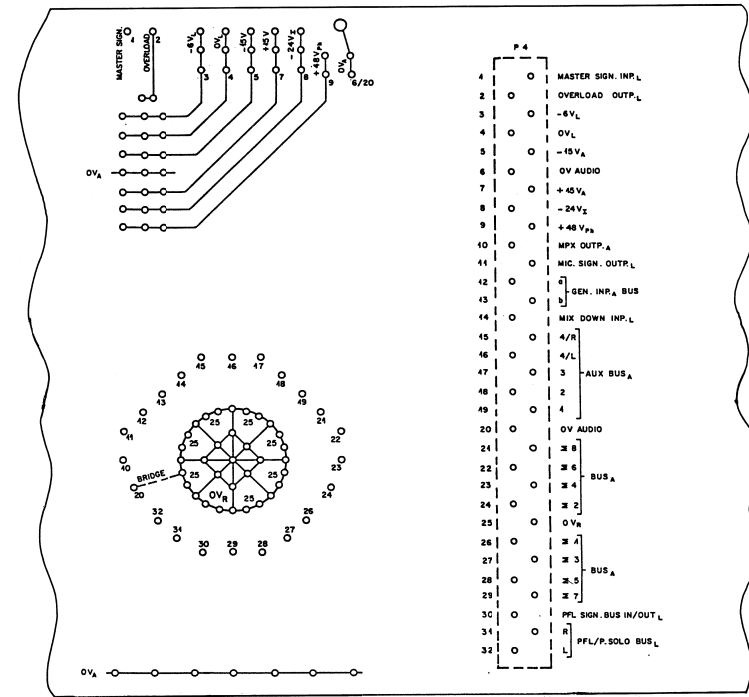

BUS BOARD 1.910. 215

. P4 - V .

- ...A = ANALOG
- ...L = LOGIC
- ...R = REFERENCE
- ...I = INTERNAL
- ...Ph = PHANTOM

3.5 Signalization

There are two signaling circuits incorporated in the audio console:

- an optical studio signaling circuit.
- a signaling system for remote control of reproduction equipment.

Studio signalization

The studio signaling system consists of a signaling field with:

- indication for "STUDIO ON" (red light)
- indication for "READY" (green light)
- return command for "ON AIR"
- "CALL" key for optical connection between speaker and control room.

Control logic: The READY and STUDIO ON signals can be enabled individually by separate nonlocking switches. The STUDIO ON signal is only through-connected if the following criteria are satisfied on at least one input unit:

- Input selector must be switched to MIC.
- MIC CUT must be disabled.
- MUTE must be disabled.
- No MIX DOWN operating.
- INPUT FADER must be open.
- At least one MASTER must be selected (Bus selection).
- At least one MASTER FADER must be open.

The relay contacts for the signalization are wired to the D-type 15 pin connector "SIGNALING STUDIO" in the connector panel.

Further information about the individual layout of the signaling system is given in section 2.

The studio signaling system runs at -24V DC. The built in power supply (-24V) may be loaded at 500mA.

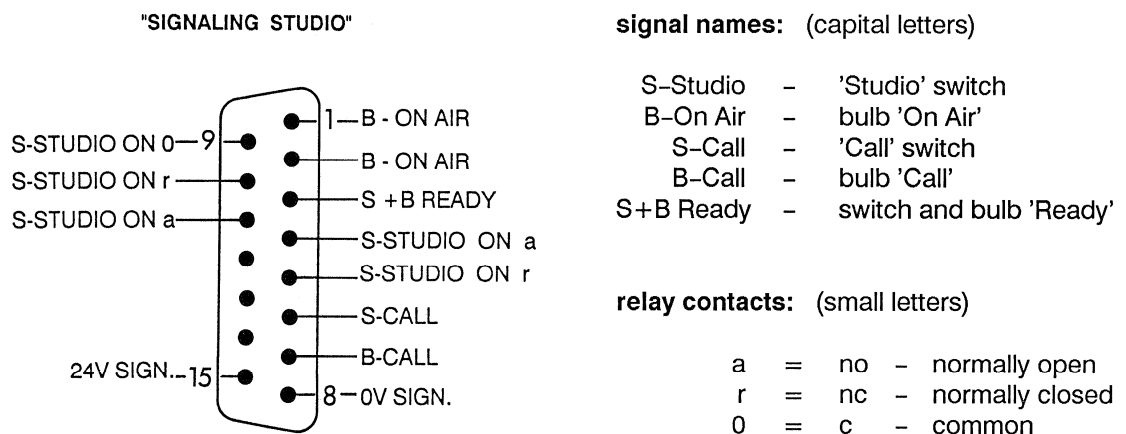

GENERAL

Circuit diagram of the studio signalization

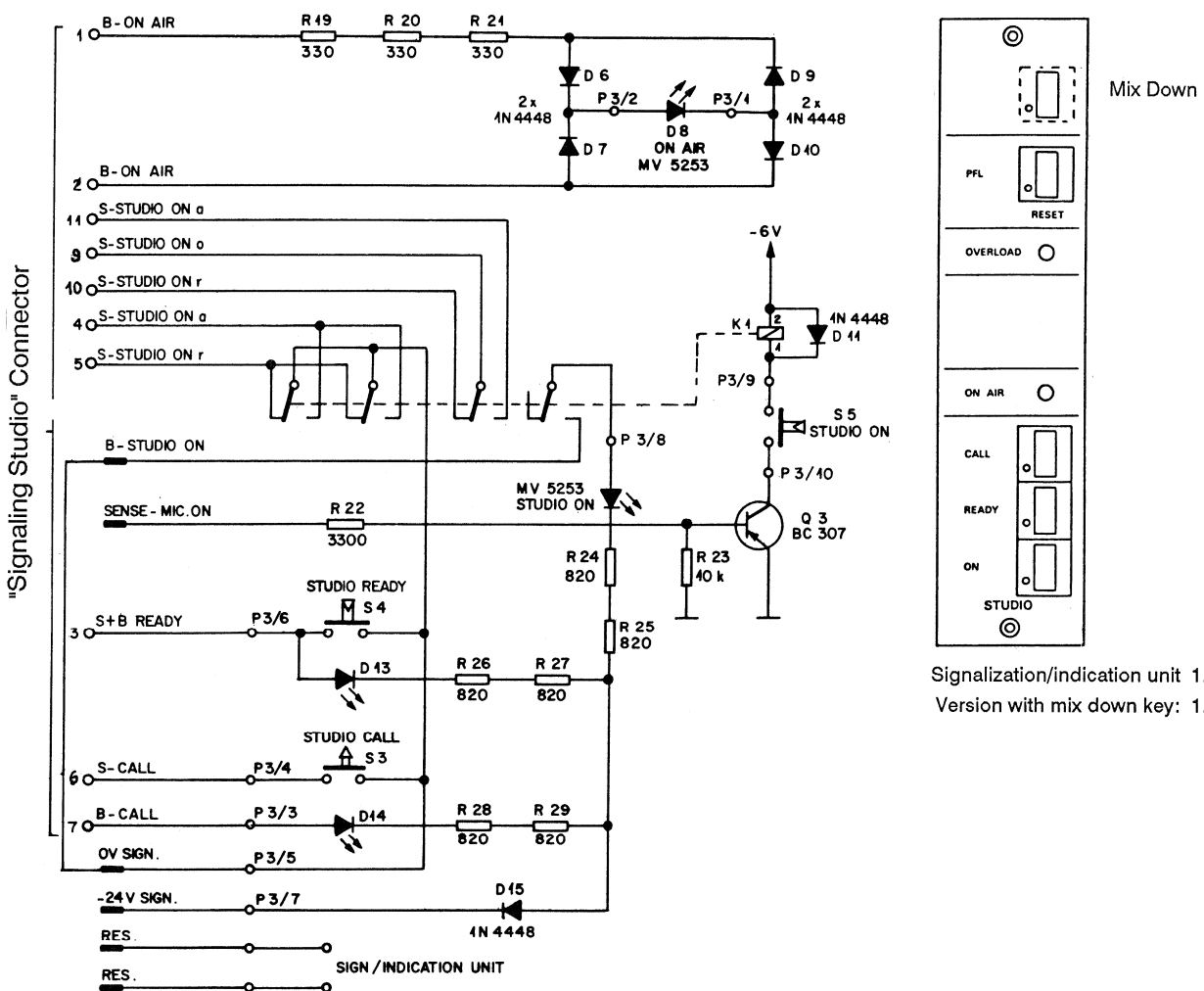

Fader start signalization

A separate remote control signal for audio reproducers is available on each channel. Depending on the position of the input selector, the insert machine for the LINE or the TAPE input is controlled individually. On the control output, -6 V are available in this case which can be loaded with up to 2.5 mA.

Because it is not possible to directly control a relay with this control voltage, all control lines of every mixing console are factory-connected to the FADER SIGNAL socket. The same socket also contains the control terminals to the fader start relays. This means that any fader start signal can be connected to any relay (audio reproducer) by means of jumpers. The Fader Signal connector consequently serves as a jumper-type programming connector.

If the control line is to be used for special applications, a relay can be controlled by means of the following circuit:

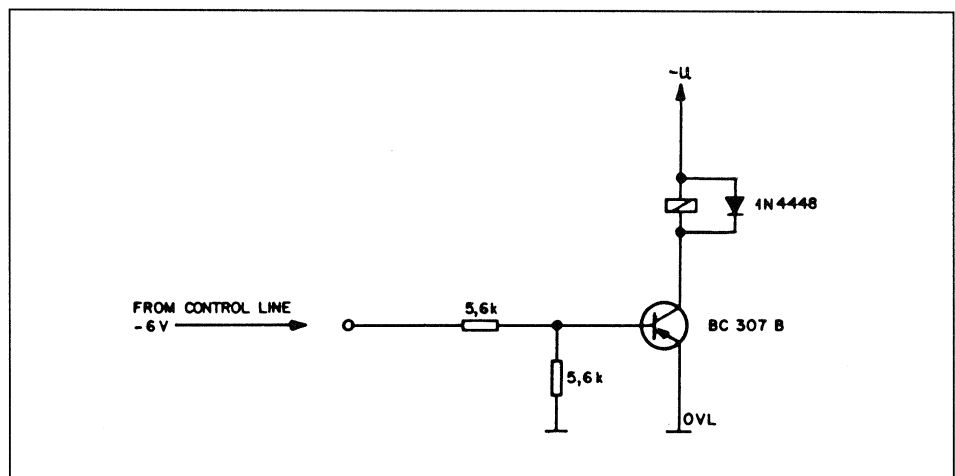

The number of available relays varies, depending on the console configuration. For each EU-standard relay board 1.915.603, there are 9 switching possibilities, i.e. 7 make contacts and 2 two-way contacts are available.

control logic: A remote signal is only switched through, if the following conditions are accomplished:

- INPUT SEL on 'Tape', if the Tape input is connected to the relay.
- INPUT SEL on 'Line', if the Line input is connected to the relay.
- If 'LINE' is selected, no MIX DOWN operating.
- MUTE must be disabled.
- INPUT FADER must be open.
- BUS SEL: at least one MASTER must be selected.
- At least one MASTER FADER must be open.

GENERAL

Block diagram for fader-start remote control of 1 input channel

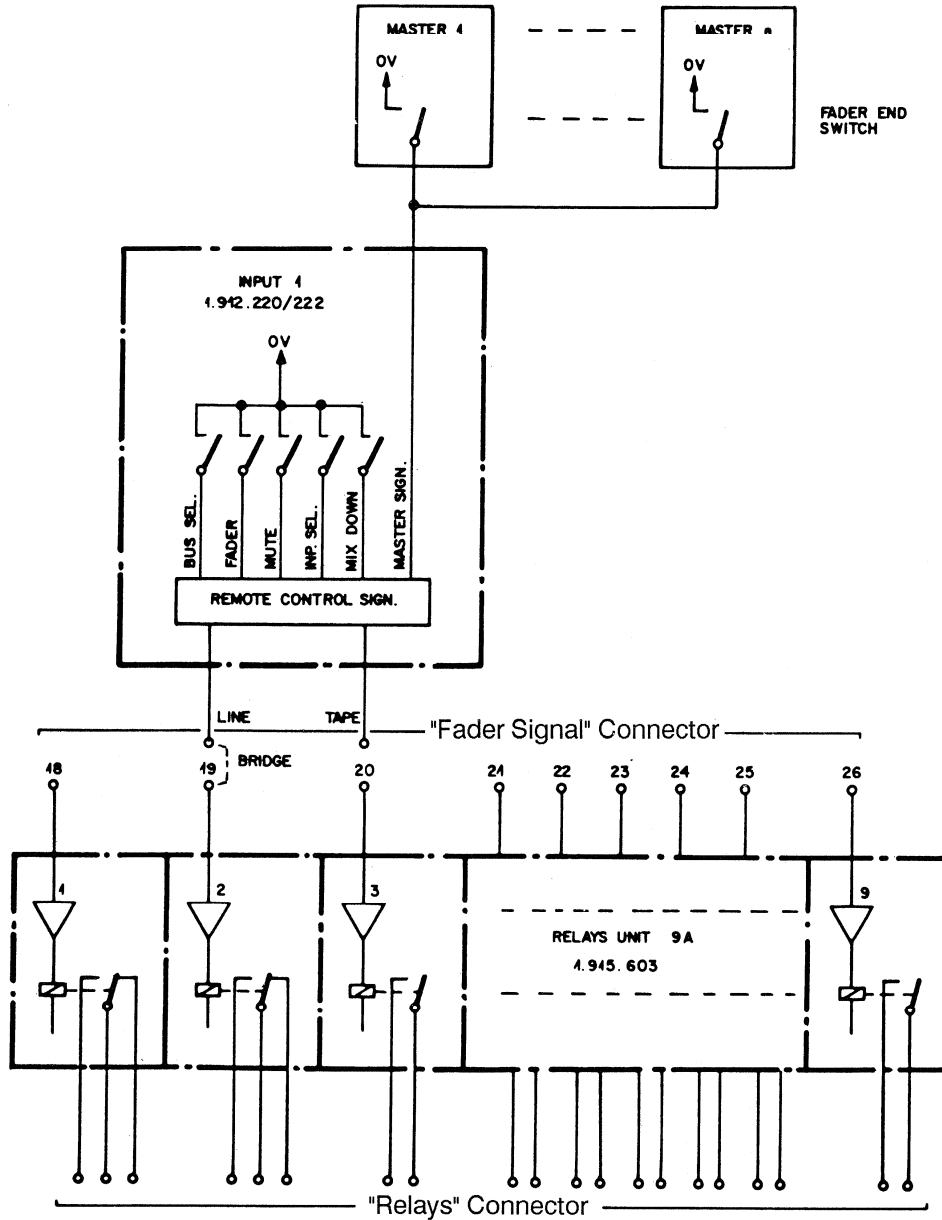

Block diagram for fader-start remote control of the entire system

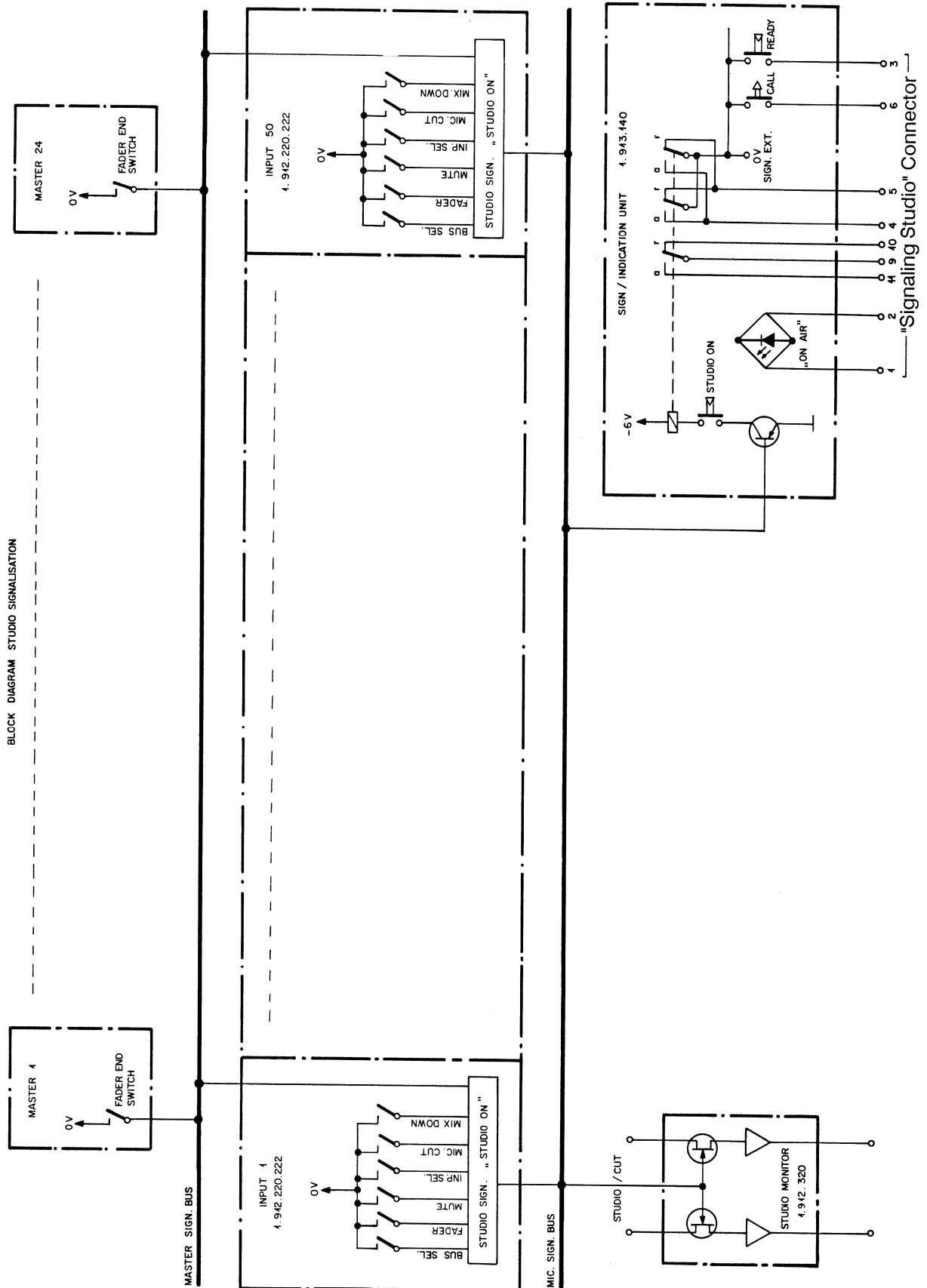

BLOCK DIAGRAM STUDIO SIGNALISATION

GENERAL

For instance: Tape 9 should be remotely controlled by input 4 (tape input):

In the programming connector "FADER SIGNAL" the remote control signal of the tape input 4 is connected to the relay control line of relay K9 with a wire bridge. The relay contacts 'K9 0' and 'K9 a' in the "RELAYS" connector may now be used for remote control of the machine.

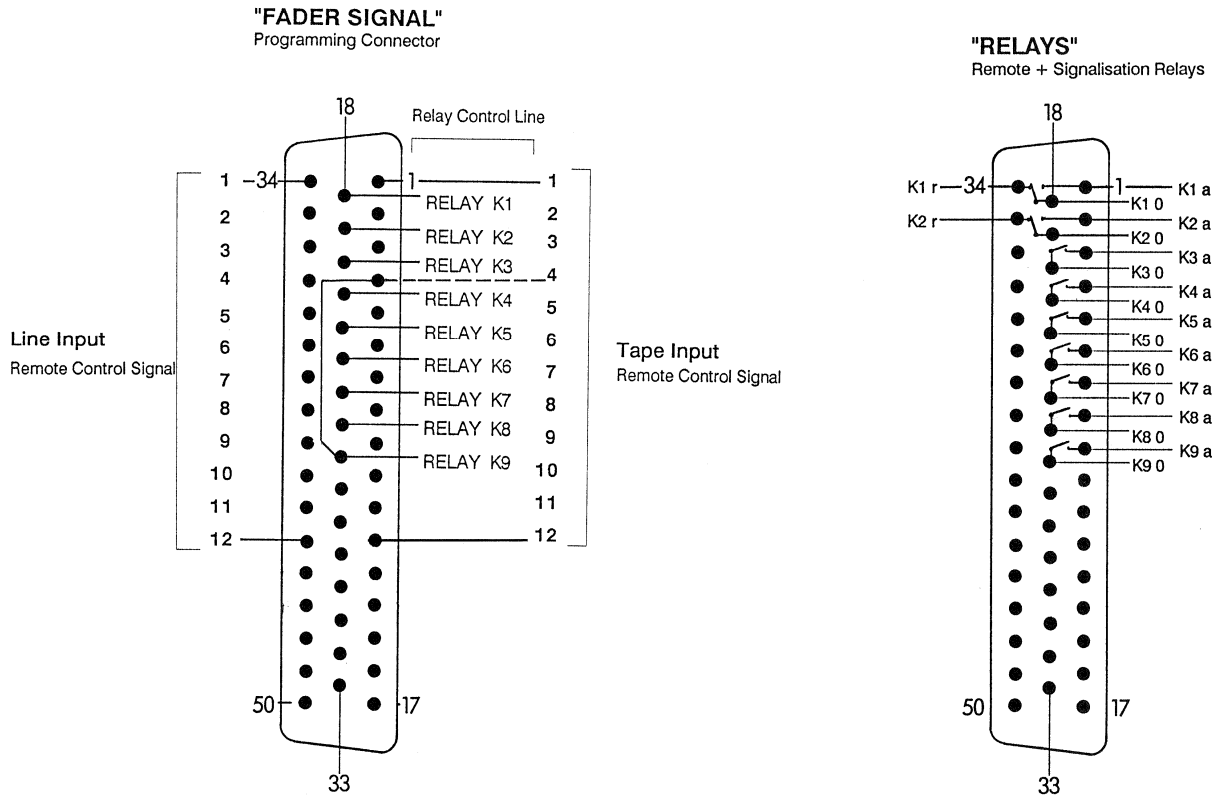

Connect pin 4 of the "FADER SIGNAL" connector to pin 26.

3.6 A Close-Up of the Chassis Ground System

Totally new solutions to a number of problems had to be found for the newly developed mixing consoles of the series 900. One of our major goals was to achieve outstanding performance in respect to cross talk and signal-to-noise ratio. The following article describes the inherent problems as well as the advanced solutions.

Problems in the layout of the chassis ground occur to some degree in all audio equipment. Careful planning is essential to a satisfactory solution. All persons involved in the design must participate: the development engineer, the laboratory technician who lays out the printed circuit board, the designer in this search for the best possible physical implementation or the technician in the assembly of the equipment.

Even the user should possess some basic knowledge in order to achieve satisfactory results. The enormous problems associated with the studio ground, including the electrical safety, would fill books, and thus cannot be covered here. The following report concentrates on the internal chassis ground concept of the Series 900 mixing consoles.

External wiring

Example: A signal current i flows through the chassis from the input to the output where it can be measured as noise.

Reason: On the copper resistor R_{Cu} of the ground conductor, the AC current i causes a voltage drop which appears at the output in the form of amplified noise. This is a serious problem, especially in non-professional equipment with unbalanced decoupling components. In professional equipment, this problem has been largely solved by incorporating balanced decoupling components (transformers or electronics).

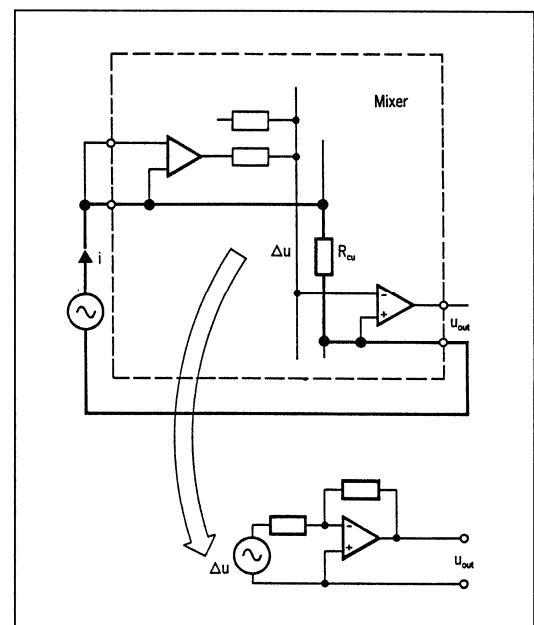

GENERAL

Solution: The ground conductors of the inputs are combined on the rear panel from where a common branch leads to the ground of the power supply. Instead of being fed into the return, the parasitic current is fed into the screening and can no longer interfere with the transmission.

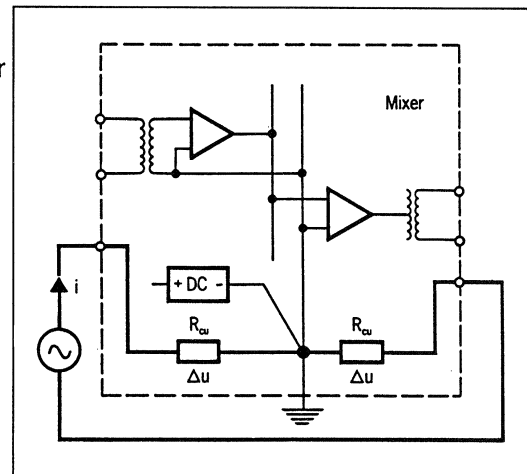

Internal ground layout The mixing console is the main switching center of the recording studio. An uncountable number of audio paths can be established, however, not all paths carry the same types of signals. The cross-talk specification are, therefore, very demanding.

Example: Target specifications of ARD:

Panorama Potentiometer	> 70dB
Dependent paths	> 80dB
Independent paths	> 85dB
Misc. programs	> 95dB
Trimmer attenuation	> 100dB

The specifications of other broadcasting companies are similar

Capacitive cross talk can be overcome through physical isolation of the channels. However, resistive cross talk can only be prevented by an optimum ground system.

Problem illustrating:

To illustrate the problem: simple bus bar arrangement. Input 1 is driven. The voltage forms a current i on resistor R . This current flows through the ground of the bus bar to the power supply. The ground conductor can be represented as a circuit with serially connected partial resistors ΔR_{Cu} .

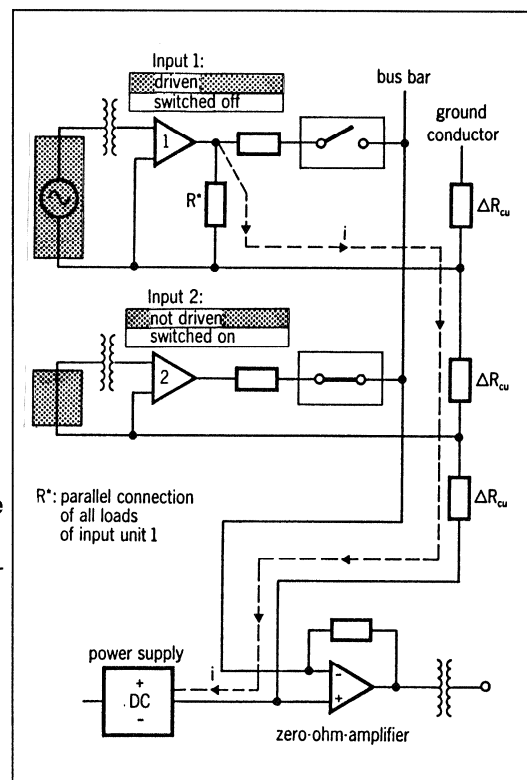

The current I causes a voltage drop Δu on ΔR_{Cu} . In the selected circuit 2, this voltage acts as a generator and causes cross talk.

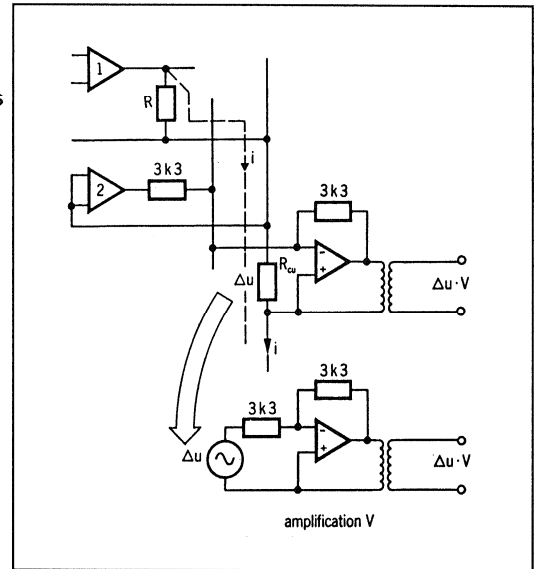

Resistive cross talk

Possible solutions:

- Installation of bus bar with large cross-section.
- Feeding the ground in the middle of the bus bar.
- Star-connected chassis ground (not feasible).
- Decoupling with transformers (outdated).
- Decoupling with differential amplifiers.

The last solution which is based on the differential amplifier is implemented in the Series 900 mixing consoles and shall now be described in more detail.

The input/output common-mode noise is compensated by this circuit. In the Series 900 audio console, a "0 V reference" line is introduced as a reference ground. Under no circumstances must this conductor be loaded.

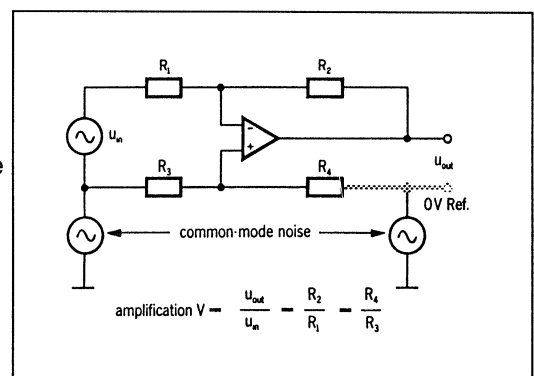

Decoupling with differential amplifiers.

The actual circuitry looks as follows:

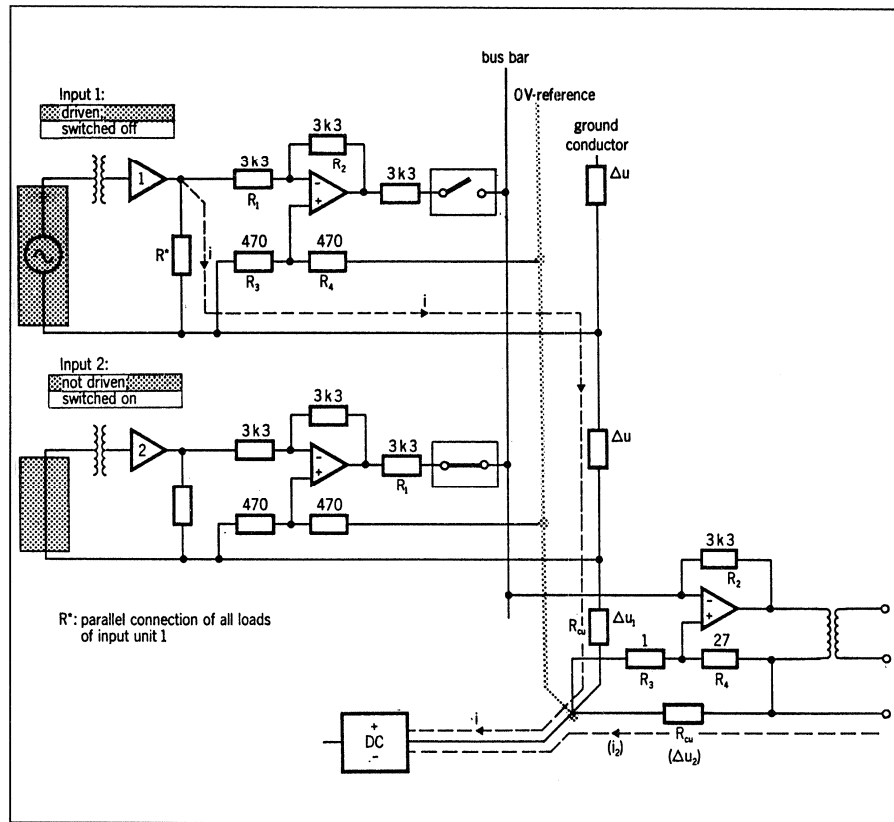

Input 1 is again driven and produces a current flows through the ground of the bus bar to the power supply. Current I produces a small voltage ΔU_1 on ΔR_{Cu} .

The built-in differential amplifier compensates this voltage. ΔU_1 is thus eliminated and resistive cross talk is cancelled. For an excellent result, the condition $R_2 : R_1 = R_3 : R_4$ must be optimally satisfied.

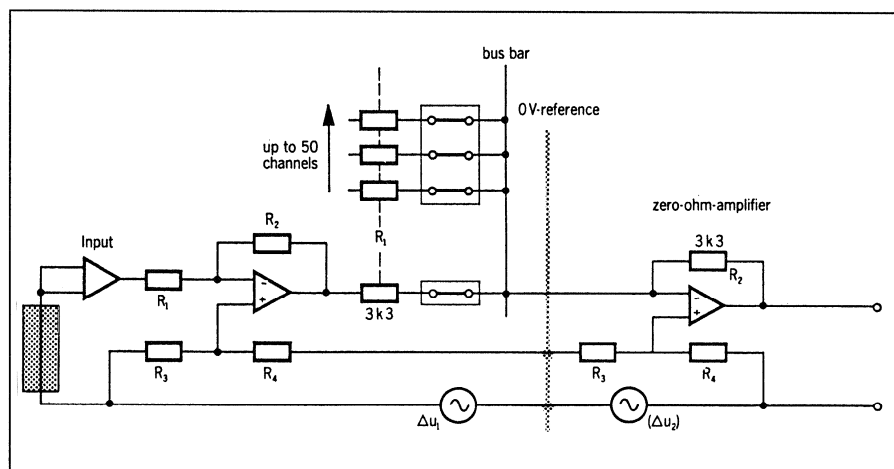

In contrast to the zero-ohm amplifier, this requirement is well satisfied in the input unit. In the zero-ohm amplifier, the input resistance R_1 varies between $3k\Omega : 1 \dots 3k\Omega : 50$, depending on the number of channels selected.

However, a significant improvement in the suppression of noise signals is still achieved.

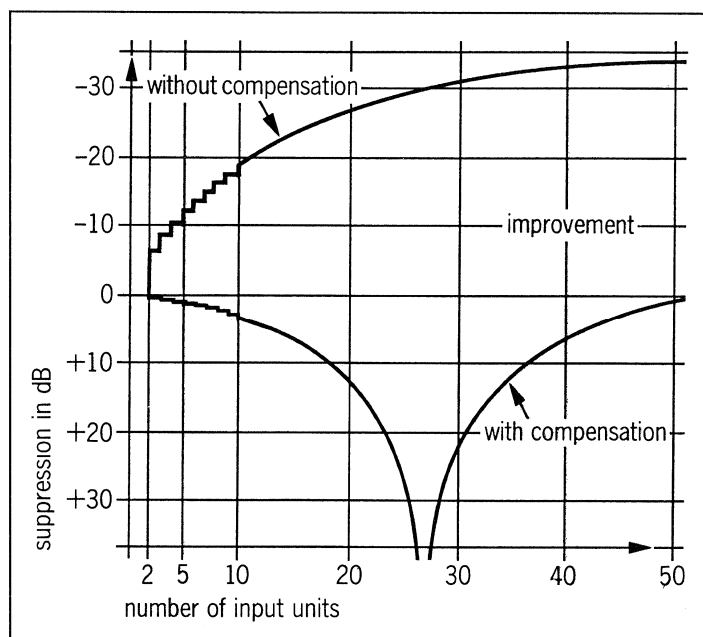

Suppression of noise signals depending on the number of input units.

Differential amplifiers are used in all major decoupling locations. This fact should, therefore, be taken into consideration in the subsequent installation of custom equipment. Because of the universal application of this advanced technology, even the largest mixing consoles we build still offer excellent cross-talk rejection and SN ratios.

GENERAL

4. Electrical Specifications

General: ■ Voltages in dBu are referred to 0.775V.

$$0 \text{ dBu} \cong 0,775 V_{\text{eff}}$$

- Channel and master faders are set to 0 dB. (Position of the linear faders)
- Line outputs are loaded with 600 Ω .
- External sources have a source impedance of $\leq 200 \Omega$.
- Data given are valid from 31.5 Hz...16 kHz.
- Levels are measured with a continuous sine wave.
(0 VU \cong 6 dB below peak recording level)

4.1 Levels

Inputs:	MIC	-70dBu ... +20dBu
	Sensitivity adjustable in 10dB steps, continuously variable with pot for fine attenuation. (max. sensitivity with open faders -90dBu \cong 0.024mV)	
	LINE	-6dBu ... +15dBu
	Sensitivity internally presettable. The external pot for fine adjust with center detent has a range of $\pm 6\text{dB}$	
	TAPE	+6dBu ... +15dBu
	Internally presettable sensitivity.	

Insertion points:	INSERT level:	0dBu.
--------------------------	---------------	--------------

Outputs:	Presettable within a range of (Main-, auxiliary-, studio-, monitor outputs)	+6dBu ... +15dBu (load 600 Ω)
	Headphones: monitor and studio	+10dBu (unloaded)

Maximum levels

Inputs:	MIC:	+24dBu
	LINE:	+24dBu
	TAPE:	+24dBu
	INSERT:	+20dBu

Outputs:	Line:	+24dBu	
	Monitor:	+22dBu	(30Hz: +18dBu)
	Studio:	+22dBu	(30Hz: +18dBu)
	Insert:	+20dBu	
	Headphones:	+20dBu	(unloaded)

Overload margin:	at the channel fader (k_{tot} 1%)	20dB
	at the master fader (k_{tot} 1%)	20dB

4.2 Level Diagram

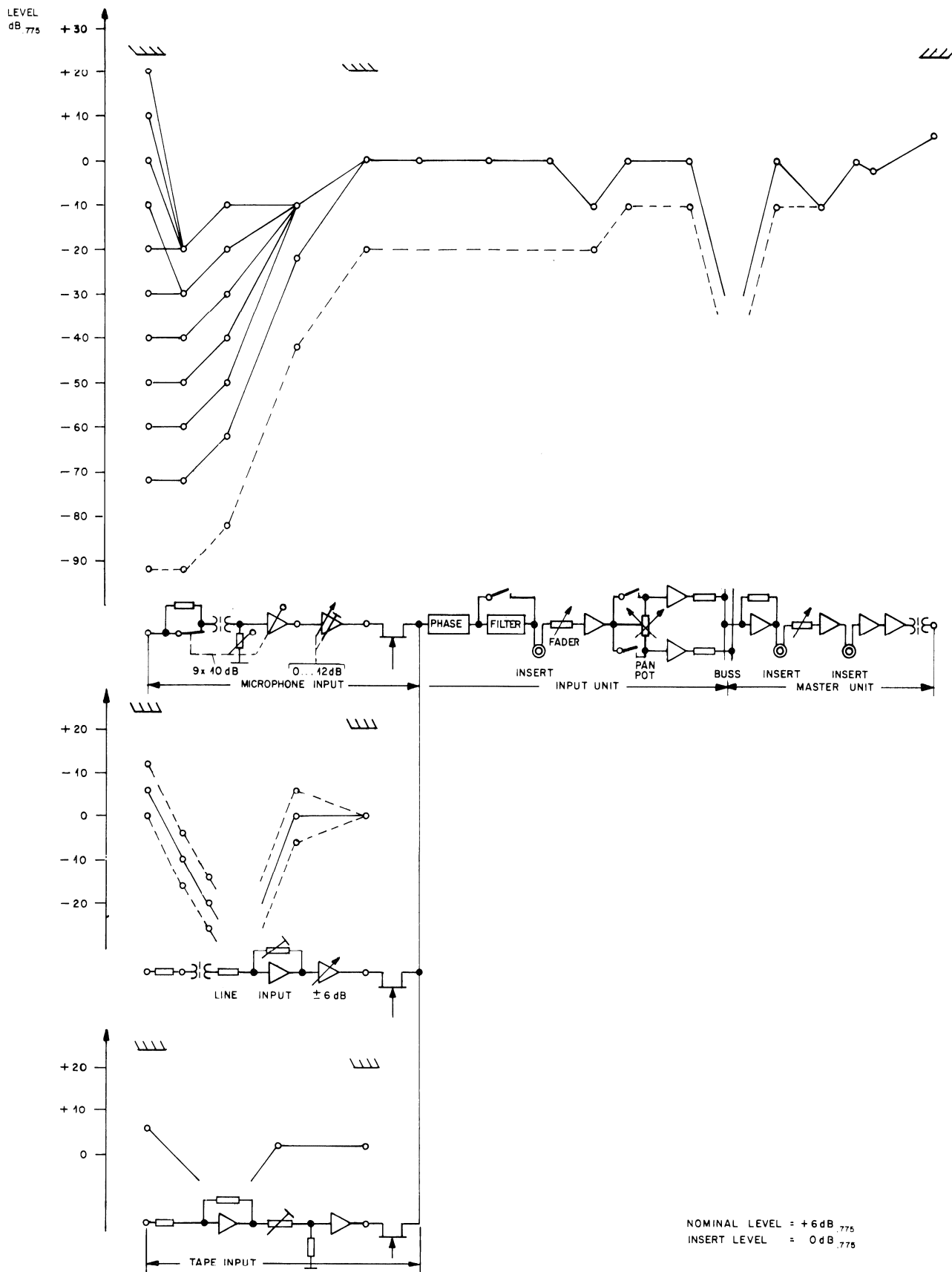

GENERAL

4.3 Impedances

Inputs:	MIC:	range -70 ... -10dB	$\geq 1,2k\Omega$
		range -10 ... +20dB	$\geq 5k\Omega$
	LINE + TAPE:		$\geq 10k\Omega$
	INSERT:		$\approx 5k\Omega$
Outputs:	Main-, auxiliary-, studio-, monitor outputs:		$\leq 50\Omega$
	Headphones output:		$\approx 135\Omega$
	INSERT:		$\leq 50\Omega$
Description:	MIC:	balanced, floating, source	$\leq 200\Omega$
	LINE:	balanced, floating, source	$\leq 200\Omega$
	TAPE:	balanced, source	$\leq 200\Omega$
	INSERT:	unbalanced, source	$\leq 200\Omega$
	Line outputs:	balanced, floating, load	$\geq 200\Omega$
	Studio output:	balanced, floating, load	$\geq 600\Omega$
	Monitor output:	balanced, floating, load	$\geq 600\Omega$
	Insert output:	unbalanced, load	$\geq 2k\Omega$
	Headphones:	unbal., recommended load	$\geq 200\Omega$

4.4 Frequency Response (Mono Input, Version "A")

	Filters off; frequency range 31,5Hz...16kHz	+0,5dB / -1dB
Filter:	Bass cut 12 dB/octave 3dB point adjustable (roll-off)	30Hz ...330Hz
	Treble filter 12 dB/octave 3dB point adjustable (roll-off) Outside audio range continuously decreasing at 12 dB/octave.	700Hz ...20kHz
Equalizer:	Treble control, shelving HF Adjustable attack frequency	$\pm 15\text{dB}$ 700Hz ...15kHz
	Treble control, bell HF Adjustable center frequency	$\pm 15\text{dB}$ 700Hz ...15kHz (Q ≈ 1)
	Bass control, shelving LF Adjustable attack frequency	$\pm 15\text{dB}$ 30Hz ...600Hz
	bass control, bell LF adjustable center frequency	$\pm 15\text{dB}$ 30Hz ...600Hz (Q ≈ 1)

Presence/absence filter, bell HMF	±15dB	
Adjustable center frequency	400Hz ... 7kHz	
Q 'narrow':	Q ≈ 3	(at max. boost)
Q 'wide':	Q ≈ 1	(at max. boost)

Presence/absence filter, bell LMF	±15dB	
Adjustable center frequency	120Hz ... 2kHz	
Q 'narrow':	Q ≈ 3	(at max. boost)
Q 'wide':	Q ≈ 1	(at max. boost)

4.5 Noise weighted

Noise voltages are measured with a true RMS voltmeter and an equivalent noise bandwidth of 30 Hz...23kHz (e.g. Siemens U2033 or equal).

Noise figure of the microphone input: **F ≤ 4dB**
(Source impedance = 200 Ω)

Signal-to-noise ratio
(Master fader closed) **> 100dB**

One channel:

Input and master faders 0 dB; line input, unity gain;
 filters off **> 98dB**
 filters on (linear) **> 90dB**

12-channels:

Input and master faders 0 dB; line input, unity gain;
 filters off **> 90dB**
 filters on (linear) **> 82dB**

24-channels:

Input and master faders 0 dB; line input, unity gain;
 filters off **> 87dB**
 filters on (linear) **> 79dB**

4.6 Distortion and Crosstalk

Distortion: Line level in frequency range **≤ 0,1%**

Crosstalk: Crosstalk from master to master **> 85dB**

4.7 Power Supply

Mains operation, mains voltage selector for:
110V, 120V, 140V, 200V, 240V AC ±10%

Internal supply voltage:	+15V	Audio
	-15V	Audio electronics
	-6V	Logic
	-24V	Logic/control
	24V	Signalization
	48V	Phantom powering

SECTION 2: Block Diagrams / Blockschaltbilder

1. **Audio Block Diagram**
2. **Signalisation Block Diagram Input Units A**
3. **Signalisation Block Diagram Input Units B**
4. **Block Diagram PFL / P.Solo System**

1. Audio Block Diagram

Projektspezifische Unterlagen

2. Signalisation Block Diagram Input Units A

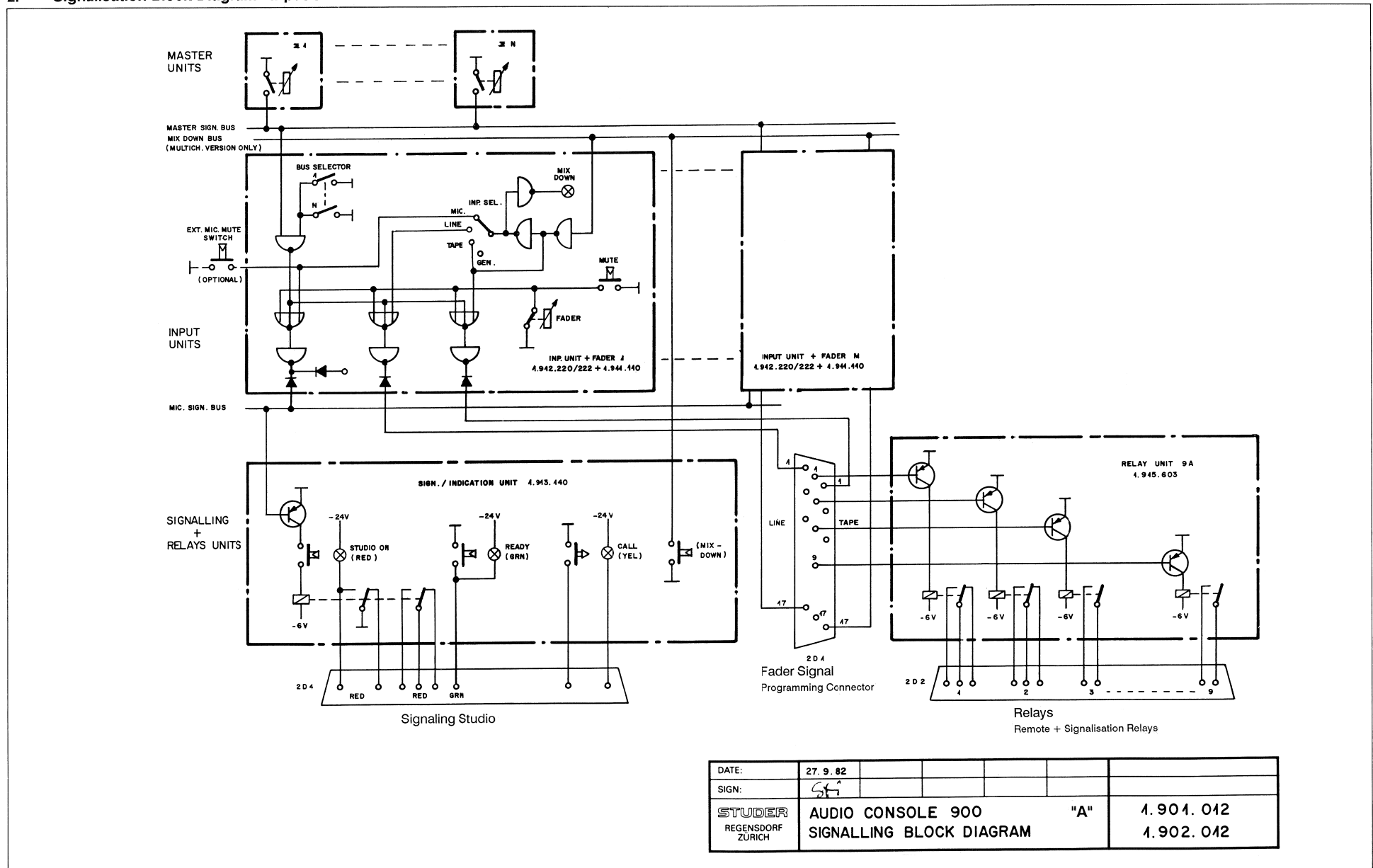

DATE:	27. 9. 82				
SIGN:	<i>St</i>				
STUDER REGENSDORF ZÜRICH	AUDIO CONSOLE 900	"A"	1. 901. 012		
	SIGNALLING BLOCK DIAGRAM		1. 902. 012		

3. Signalisation Block Diagram Input Units B

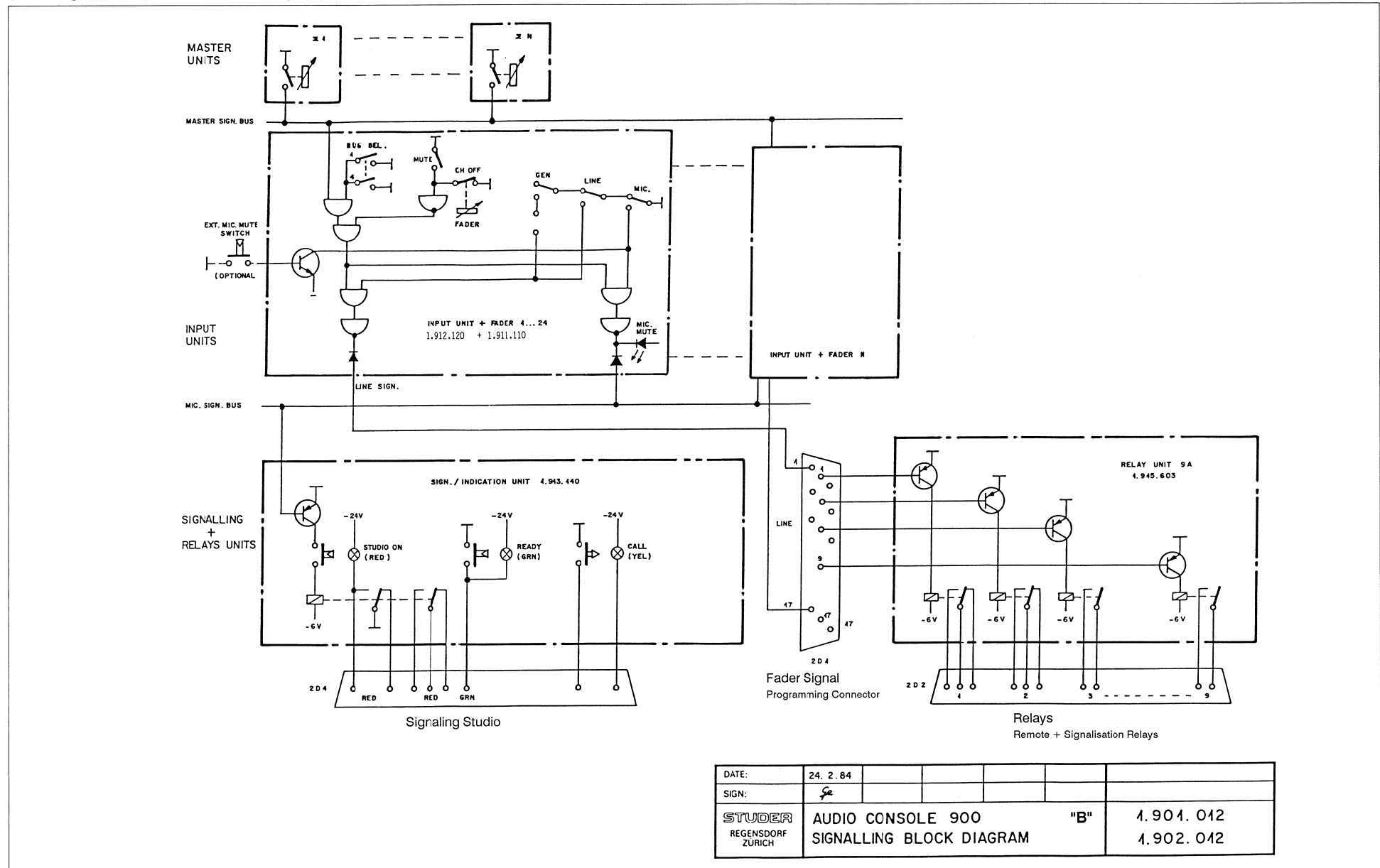

DATE:	24. 2. 84				
SIGN:	<i>Se</i>				
STUDER REGENS DORF ZURICH	AUDIO CONSOLE 900 SIGNALLING BLOCK DIAGRAM	"B"	1.901.042	1.902.042	

4. Block Diagram PFL / P.Solo System

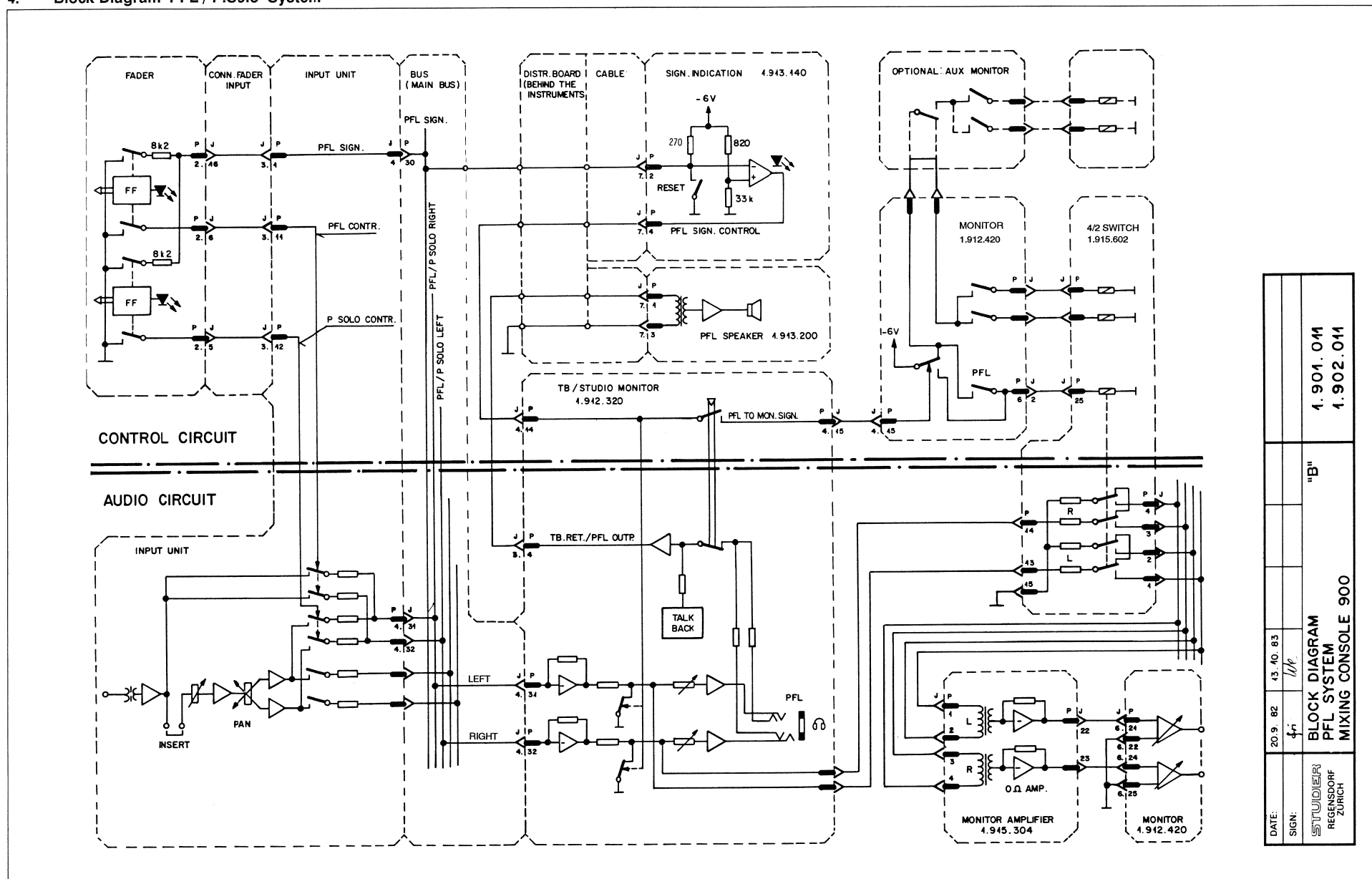

DATE:	20.9.82	13.10.83			
SIGN:	fr	Wp			
STUDIOER REGENSDORF ZURICH			"B"		
BLOCK DIAGRAM PFL SYSTEM MIXING CONSOLE 900			1.904.041 1.902.011		

KAPITEL 3: Einmessen

1.	Allgemeines	1
1.1	Pegel-Definition	1
1.2	Umrechnungstabelle Spannungspegel \leftrightarrow Dezibel	2
1.3	Notwendigkeit des Einmessens	3
1.4	Benötigte Messgeräte und Hilfsmittel	3
1.5	Elektrostatisch empfindliche Bauteile "ESE"	3
1.6	Messgrundlagen	4
1.7	Messaufbau	5
1.8	Entmagnetisieren von Mikrofon-Eingangsübertragern	7
2.	Abgleichanleitungen Faderpanel	8
2.1	Eingangs-Fader Mono/Stereo 1.911.110...122	8
2.2	Summen-Fader Mk II 1.911.315...335	9
3.	Abgleichanleitungen Input-Panel	10
3.1	Eingangseinheiten Mono "A"..... 1.912.220...226	10
3.2	Eingangseinheiten Stereo Hochpegel "A"..... 1.912.240...243	12
3.3	Eingangseinheiten Stereo Universal "A"..... 1.912.250...253	13
3.4	Eingangseinheiten Mono "B"..... 1.912.120/122	14
3.5	Eingangseinheiten Stereo Hochpegel "B"..... 1.912.141...145	15
3.6	Auxiliary Mastereinheit	1.912.310..... 16
3.7	Kontrollraum Monitor	1.912.420..... 16
3.8	Studio Monitor und Kommandoeinheit	1.912.320..... 18
4.	Abgleichanleitungen Instrumenten-Panel.....	21
4.1	PPM-Zeigerinstrumente	1.913.220/221 ... 21
4.2	VU-Zeigerinstrumente	1.913.230/231 ... 21
4.3	Korrelator 2CH / 4 CH	1.913.210/211 ... 22
4.4	AUX-Anzeigeinstrumente VU / PPM	1.913.130..... 23
4.5	Testgenerator	1.913.150..... 24

1. Allgemeines

1.1 Pegel-Definition

Pegelangaben: Nennpegelangaben in dBu basieren ausschliesslich auf einem festgelegten Spannungswert als Bezugsgrösse:

0 dBu \cong 0,775 V_{eff}

Nennpegel in dBu:

Nennpegel = Pegel bei Vollaussteuerung

Der Nennpegel entspricht dem Pegel bei Vollaussteuerung. Die Begriffe Nominalpegel, Studio- und Leitungspegel werden synonym verwendet. Der Nennpegel gilt für relative Pegelangaben als 0dB-Wert.

Typische Nennpegel sind:

+6dBu	\cong	1,55V _{eff}
+10dBu	\cong	2,45V _{eff}
+15dBu	\cong	4,36V _{eff}

Aussteuerungspegel:

0 dB PPM	=	Nennpegel
0 VU	=	Nennpegel minus 6 dB*

* 6dB entsprechen einem verbreiteten Wert für den Vorlauf (Lead) des VU-Instrumentes.

PPM-Pulte Peak Program Meter zeigen als Quasispitzenwert-Instrumente den Effektivwert einer Sinusspannung an. Ein Signal mit Nennpegel ergibt eine 0dB-Anzeige.

VU-Pulte VU-Instrumente zeigen bei einem Dauerton einen um den Vorlauf zu hohen Wert an. Für eine 0VU-Anzeige muss der Pegel des Testsignals um den Vorlauf vermindert werden.
 VU-Pulte werden häufig auf einen Nennpegel von +10dBu eingestellt, d.h. bei 6dB Vorlauf des VU-Meters wird ein Pegel von +4dBu mit 0VU angezeigt.

Verstärkung/Dämpfung:

Relative Pegelangaben in dB geben Auskunft über das Verstärkungs- bzw. Dämpfungsmass einer aktiven (z.B. Verstärkerstufe) oder passiven (z.B. Potentiometer) Schaltungskomponente innerhalb eines Schaltkreises. Die folgende Tabelle setzt Spannungsverhältnisse (Ausgang ÷ Eingang) zu Dezibelwerten in Beziehung (gerundete Faktoren):

	dB	0	1	2	3	6	10	14	20	26	34	40
Faktor	Verstärkung	1	1,1	1,2	1,4	2	3,2	5	10	20	50	100
	Dämpfung	1	0,9	0,8	0,7	0,5	0,3	0,2	0,1	0,05	0,02	0,01

1.2 Umrechnungstabelle der Spannungspegel: Volt ↔ dBu

$\frac{U_1}{U_2}$	μV ————— dBu				$\frac{U_1}{U_2}$	μV ————— dBu			
	mV					mV			
	V	dBu	dBu	dBu	V	dBu	dBu	dBu	dBu
1	0,775	±0	-60	-120	31,6	24,5	+30	-30	-90
1,12	0,87	+1	-59	-119	35,5	27,5	+31	-29	-89
1,26	0,98	+2	-58	-118	39,8	30,8	+32	-28	-88
1,41	1,09	+3	-57	-117	44,7	34,6	+33	-27	-87
1,59	1,23	+4	-56	-116	50,1	38,8	+34	-26	-86
1,78	1,38	+5	-55	-115	56,2	43,6	+35	-25	-85
2,00	1,55	+6	-54	-114	63,1	48,9	+36	-24	-84
2,24	1,73	+7	-53	-113	70,8	54,8	+37	-23	-83
2,51	1,95	+8	-52	-112	79,4	61,5	+38	-22	-82
2,82	2,18	+9	-51	-111	89,1	69,0	+39	-21	-81
3,16	2,45	+10	-50	-110	100	77,5	+40	-20	-80
3,55	2,75	+11	-49	-109	112	86,9	+41	-19	-79
3,98	3,08	+12	-48	-108	126	97,5	+42	-18	-78
4,47	3,46	+13	-47	-107	141	109,4	+43	-17	-77
5,01	3,88	+14	-46	-106	159	122,8	+44	-16	-76
5,62	4,36	+15	-45	-105	178	137,7	+45	-15	-75
6,31	4,89	+16	-44	-104	200	154,5	+46	-14	-74
7,08	5,48	+17	-43	-103	224	173,4	+47	-13	-73
7,94	6,15	+18	-42	-102	251	194,6	+48	-12	-72
8,91	6,90	+19	-41	-101	282	218,3	+49	-11	-71
10,0	7,75	+20	-40	-100	316	244,9	+50	-10	-70
11,2	8,69	+21	-39	-99	355	274,8	+51	-9	-69
12,6	9,75	+22	-38	-98	398	308,4	+52	-8	-68
14,1	10,9	+23	-37	-97	447	346,0	+53	-7	-67
15,8	12,3	+24	-36	-96	501	388,2	+54	-6	-66
17,8	13,8	+25	-35	-95	562	435,6	+55	-5	-65
20,0	15,5	+26	-34	-94	631	488,7	+56	-4	-64
22,4	17,3	+27	-33	-93	708	548,4	+57	-3	-63
25,1	19,5	+28	-32	-92	794	615,3	+58	-2	-62
28,2	21,8	+29	-31	-91	891	690,4	+59	-1	-61
31,6	24,5	+30	-30	-90	1000	774,6	+60	±0	-60

Die fettgedruckte Kolonne enthält Spannungswerte. Die drei anschliessenden Kolonnen zeigen die entsprechenden Dezibelwerte bei Interpretation der Spannungen als Volt, Millivolt oder Mikrovolt. Die Kolonne U1/U2 gibt die Spannungsverhältnisse an, die den auf Volt bezogenen dBu-Werten entsprechen.

Der Tabelle liegt die Definition $0\text{dBu} \cong 0,775V_{\text{eff}}$ zugrunde.

1.3 Notwendigkeit des Einmessens

Jedes ab Herstellerwerk ausgelieferte Mischpult verfügt über ein Prüfprotokoll, in dem die Daten der Endprüfung eingetragen sind, wie:

- Abgleich auf kundenspezifischen Nennpegel
- Frequenzgang, Klirrfaktor, Geräuschabstand, Rauschspannung und Übersprechdämpfung.

Das Einmessen des Mischpultes ist bei Änderungen der Betriebsbedingungen (Nennpegel) am Einsatzort oder nach Modifikationen am Mischpult erforderlich. Einzige turnusgemässe Wartungsmassnahme bildet das nachfolgend beschriebene Entmagnetisieren der Eingangsübertrager. (vgl. 1.8)

Hinweis: Ab Herstellerwerk ausgelieferte (Ersatz-) Einschübe sind werkseitig auf einen Nennpegel von +6dBu abgeglichen und können direkt in das einzumessende Mischpult eingesetzt werden.

1.4 Benötigte Messgeräte und Hilfsmittel

- Tonfrequenz-Generator / $R_s \leq 200\Omega$
- NF-Voltmeter, $R_{z_{in}} \geq 10k\Omega$
- 2 Kanal Kathodenstrahl-Oszillograph
- Abgleich-Schraubenzieher, Grösse 2
- Sammelschienen-Adapter zur Kontaktierung ausgebaute Einschübe mit der Sammelschiene. Es werden mindestens benötigt:

1 Verlängerungsprint mit 32-Pol Steckern	Best.-Nr. 1.228.322.81
2 Verlängerungsprints mit 64-Pol Steckern	Best.-Nr. (1 Stk.) 1.228.327.81
- 2 Ausziehwerkzeuge für Einschübe Best.-Nr. (1 Stk.) 1.912.000.06
- Feste, nicht leitende Matte (Gummi oder Karton), als Unterlage für ausgebaute, über den Adapter mit der Sammelschiene kontaktierte Einschübe (werden mit Vorteil auf das Bedienungsfeld des Mischpultes gelegt). Abmessung ca. 40 x 25 cm.

1.5 Elektrostatisch empfindliche Bauteile "ESE"



Statische Elektrizität:

Viele Materialien der heutigen Arbeitswelt sind mögliche Quellen statischer Elektrizität. Unter geeigneten Voraussetzungen können sich dadurch Gegenstände und Personen auf sehr hohe Potentiale aufladen. Bei Entladung dieser Potentiale können Impulse von beachtlicher Spitzenleistung auftreten. Findet auch nur ein kleiner Teil dieser Energie seinen Weg in Bauelemente der Elektronik, werden diese zerstört oder beschädigt.

EINMESSEN

Umgang mit ESE-Platinen: Es muss deshalb unser Ziel sein, unsere Produkte vor Fehlern und Mängeln durch elektrostatische Entladung zu bewahren. Richtiger Umgang mit elektronischen Baugruppen ist im Bereich der Geräterwartung von grösster Wichtigkeit. Dabei gilt es einige einfache Verhaltenshinweise zu befolgen:

1. Entlade Dich durch Anfassen von Erde, bevor Du eine elektronische Baugruppe in die Hand nimmst.
2. Gib dem Partner zuerst die Hand und dann die Baugruppe.
3. Fasse einen bestückten Print grundsätzlich nur am Rand oder an der Frontplatte an.
4. Berühre niemals Leiterbahnen, Anschlusspunkte oder Bauelemente, ohne Dich vorher zu entladen.
5. Schalte die Netzspannung aus, bevor Du eine ESE-Baugruppe herausnimmst oder einsteckst.
6. Transportiere und lagere ESE-Baugruppen immer in ESE-Verpackungen.
7. Arbeite nur mit ESE-geeigneten und geprüften Werkzeugen.
8. Trage bei Arbeiten an elektrischen Baugruppen, egal ob ESE oder nicht, immer das Erdungsarmband.
9. Halte Styropor, PVC-Folien, Plastiksäcke und ähnliche Materialien weit entfernt von ESE-Baugruppen.

Wir empfehlen, den Arbeitsplatz mit einer geerdeten Unterlage auszurüsten:

ESE-Schutzmatte Dieses Kit enthält eine Schutzmatte (60 × 70cm) mit Erdungskabel und Erdungsarmband für Arbeiten an elektrischen Baugruppen. Best. Nr. **20.020.001.44**

1.6 Messgrundlagen

Temperatur: Das Einmessen des Mischpultes erfolgt bei erreichter Betriebstemperatur. (ca. 15 Minuten nach dem Einschalten)

Last:

- Einschleifpunkte (INSERTs), Monitor-, Vorhör- und Kommando- (TB-) Ausgänge sind **nicht** zu belasten ($R_L \geq 10k\Omega$)
- Leitungsausgänge (Gruppen, Summen, Hilfssummen) sind mit **600 Ω Last** abzuschliessen.

Testsignal: Sinuston / 1 kHz

Pegelreferenz: **Alle Angaben dieser Einmessanleitung beziehen sich auf einen Nennpegel von +6dBu.**
Andere Nennpegel bedingen Messwerte gemäss folgender Tabelle:

Pegelübersicht:

Nennpegel	Insert symmetrisch	Insert asymmetrisch	Leitungs- ausgänge	Anzeige OVU (6dB Vorlauf)	Anzeige 0dB (PPM)
+6dBu	+6dBu	0dBu	+6dBu	0dBu	+6dBu
+10dBu	+10dBu	+4dBu	+10dBu	+4dBu	+10dBu
+15dBu	+15dBu	+9dBu	+15dBu	+9dBu	+15dBu

Insert-Pegel: Die symmetrischen Einschleifpunkte liegen auf Nennpegel, während asymmetrische Ausführungen einen um 6dB tieferen Pegel führen.

1.7 Messaufbau

Ein- und Ausbau der Einschübe:

Die einzumessenden Einheiten müssen ausgebaut und über Printverlängerungen wieder ans Mischpult angeschlossen werden.

Die 0Ω -Bus-Verstärker sind empfindlich auf Spannungsspitzen, wie sie beim Einstecken der Baugruppen unter Spannung entstehen können. Zum Schutz des Pultes und der Peripherie dürfen folgende Einschübe **nur bei ausgeschaltetem Pult** aus- oder eingebaut werden:

- VCA-Fader; Master-Fader; Gruppen-Fader; Aux-Master Einheit; Studio Monitor; CR Monitor.

Symmetrische Messgeräte:

NF-Voltmeter und NF-Generator müssen grundsätzlich über **symmetrische** Ein- resp. Ausgänge verfügen.

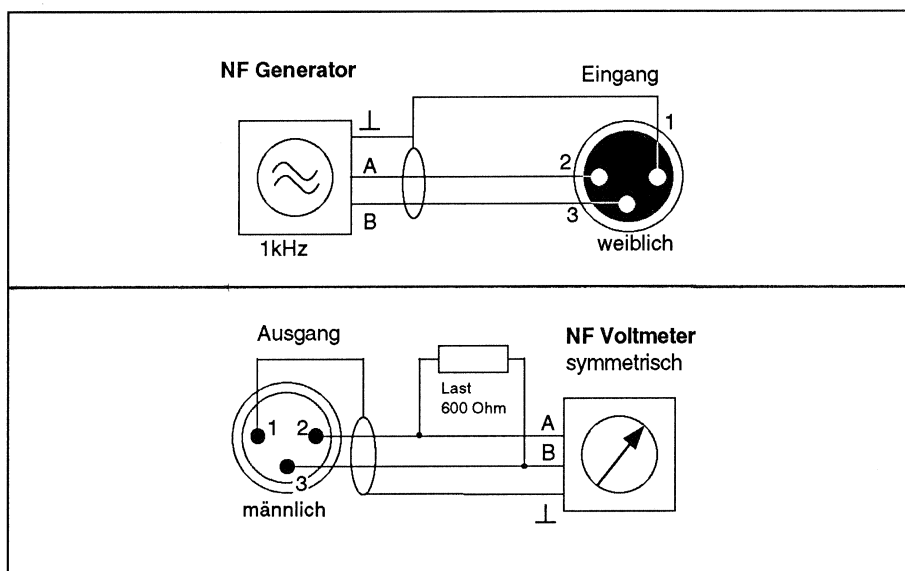

Fig. 1 Anschluss des NF-Generators mit symmetrischer Leitung. Messungen mit dem NF-Voltmeter erfolgen je nach Messpunkt mit oder ohne Belastung des Ausganges.

Asymmetrische Messgeräte:

Asymmetrischen Messgeräten ist ein Symmetrier-Übertrager vorzuschalten. Ist dies nicht möglich, kann behelfsmässig wie folgt beschaltet werden:

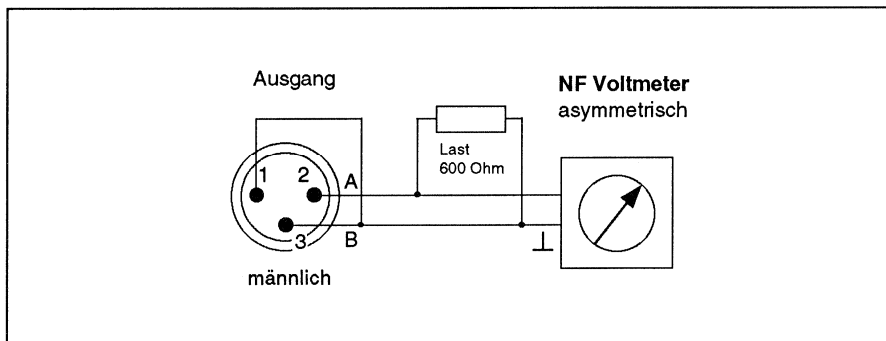

Fig. 2

Die **b**-Leitung (3) mit der Audiomasse (1) verbunden bildet mit der **a**-Leitung (2) einen asymmetrischen Messpunkt. Diese Schaltung ist jedoch nicht für Messungen bei hoher Aussteuerung anwendbar. (Clipping-Effekt bei elektronisch symmetrierten Ausgängen, z.B. INSERT)

EINMESSEN

Messung an Insertpunkten: Die Schaltkontakte der Klinkenbuchsen unterbrechen den Signalfluss durch den Kanal, sobald ein Stecker angeschlossen wird. Bei Messungen an INSERT-Punkten darf der Signalweg jedoch nicht unterbrochen werden. Aus diesem Grund ist folgendes zu beachten:

- Asymmetrische Inserts müssen durchverbunden werden (SEND → RETURN).
- Symmetrische Inserts können an der Insert SEND-Buchse gemessen werden. Das Signal wird nur bei Belegung der RETURN-Buchse unterbrochen.

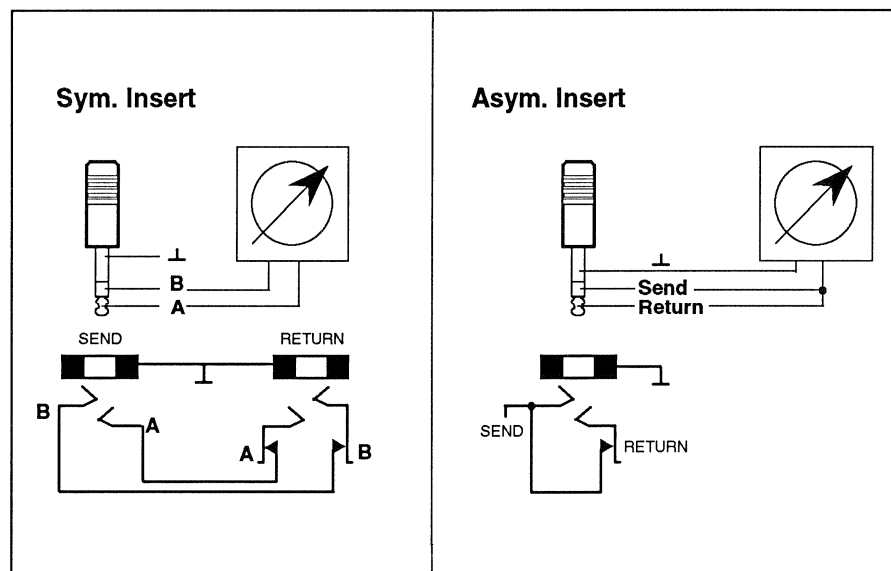

Fig. 3 Messung an symmetrischen und asymmetrischen Inserts. Der Signalfluss darf nicht unterbrochen werden.

1.8 Entmagnetisieren von Mikrofon-Eingangsübertragern

Unerlaubtes Anschliessen asymmetrischer Eingangsquellen oder unbeabsichtigter Masseschluss der a/b-Tonadern von Mikrofon-Eingängen mit zugeschalteter Phantomspeisung treiben die Eingangsübertrager in die Sättigung und bewirken deren permanente Magnetisierung (Remanenz).

Diese äussert sich nachteilig durch den sogenannten Mikrofonie-Effekt: Leichte mechanische Einwirkungen auf das Mischpult, z.B. das Antippen von Einschüben, bewirken eine hörbare Modulation über die Lautsprecher, auch bei nicht belegten Mikrofon-Eingängen.

Auch kann sich Remanenz in den Übertragern im Laufe längerer Betriebsdauer kumulieren.

Es empfiehlt sich deshalb, alle Mikrofon-Eingänge periodisch, und vor Einmessvorgängen, zu entmagnetisieren:

- Vorgehen:**
- Mischpult ausschalten. (zum Schutze angeschlossener Lautsprecher)
 - NF-Generator an Mikrofon-Eingang anschliessen.
Das Testsignal muss gleichspannungsfrei sein, damit der Eingangsübertrager nicht magnetisiert wird. Die folgende Schaltung sperrt Gleichstromanteile:

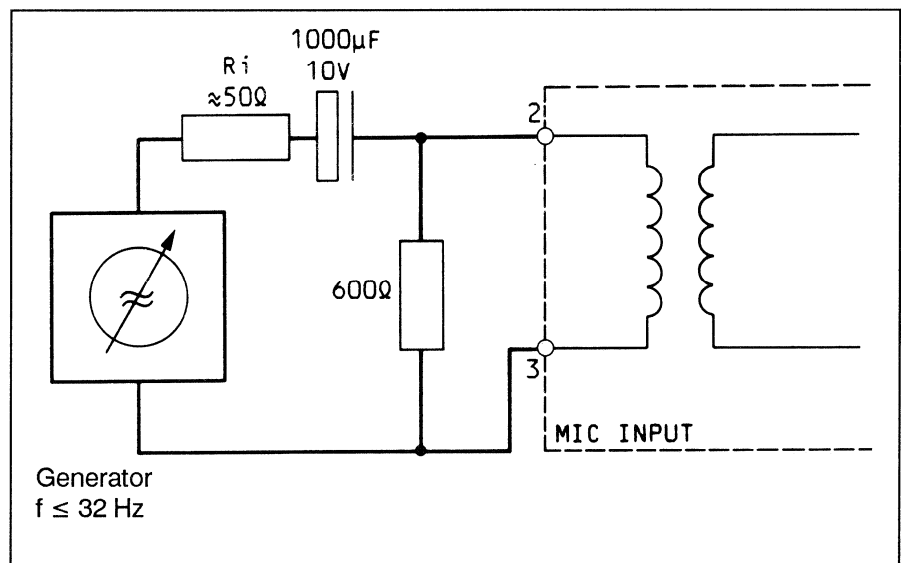

Fig. 4 Anschluss des NF-Generators an Mikrophoneingänge.

- Kondensator $C = 1000\mu F / 10V$ sperrt Gleichstrom-Anteile.
- Widerstand $R_{600\Omega}$ dient der Entladung des Kondensators von Gleichstrom-Anteilen.
- Frequenz $\leq 32\text{Hz}$ sukzessive auf Einspeispegel von $0V \dots 3V$ erhöhen.
- Einspeispegel **langsam** auf $0V$ zurückregeln.

2. Abgleichanleitungen Faderpanel

Die jeweilige Fadereinheit zum Einmessen ausbauen und den Printstecker P1 über Verlängerungskabel mit dem Pult verbinden.

Für den Abgleich sind Filter, Equalizer, Balance- bzw. Panoramapotentio- meter auszuschalten.

2.1 Eingangsfader Mono/Stereo,

1.911.110/112/120/122

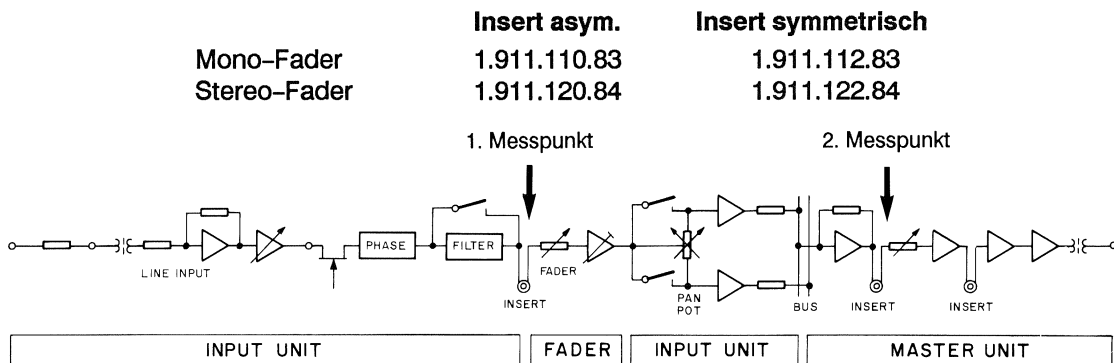

- Testsignal mit Nennpegel in LINE Eingang einspeisen.
- AC-Voltmeter an PF Insert Send der Eingangseinheit anschliessen. (1. Messpunkt)
- Regler LINE GAIN der Eingangseinheit in Mittelstellung einrasten und Filter ausschalten. Werden am PF Insert nun nicht die folgenden Werte gemessen, muss die Eingangseinheit eingemessen werden. (siehe 3.)
 - a) asymmetrischer Insert: **0dBu**
 - b) symmetrischer Insert: **+6dBu**
- Fader auf **0dB** positionieren.
- Auf der Eingangseinheit eine Summe (Master Unit) anwählen und Voltmeter am PF Insert SEND dieser Summe anschliessen. (entspricht dem Pegel nach dem Eingangs-Fader; 2. Messpunkt)
- Abgleich des Pegels mit den Trimmern R23 des Mono Faders bzw. mit R109 (links) und R209 (rechts) des Stereo Faders:
 - a) bei asymmetrischem Summen-Insert: **0dBu**
 - b) bei symmetrischem Summen-Insert: **+6dBu**

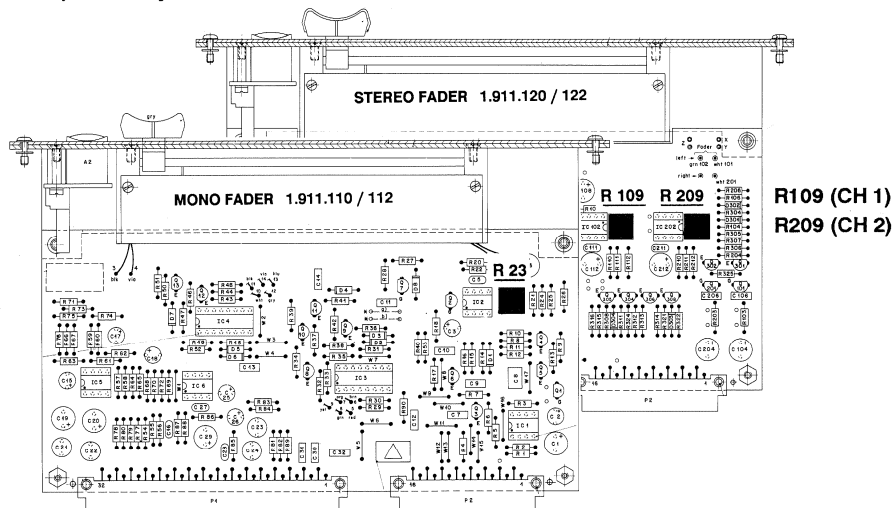

Fig. 5 Abgleich Elemente der Mono- und Stereo-Fader.

2.2 Summen-Fader Mk II

1.911.315/325/335

	ohne Limiter	mit Limiter
Mono Master Unit Mk II	1.911.315	1.911.317
Dual Master Unit Mk II	1.911.325	1.911.335

Die verwendeten Platinen tragen die Nummern 1.911.323 (Kanal 1 bzw. Mono) und 1.911.324 (Kanal 2).

Pegel des AF-Inserts:

- Testsignal mit Nennpegel über einen richtig eingemessenen Line Eingang einspeisen und auf gewünschte Summe schalten.
- Eingangsfader und Summenfader auf 0 dB aufziehen.
- Voltmeter an AF-INSERT OUT anschliessen.
- AF Insert OUT mit R142 für CH1 (bzw. R342 für CH2) auf 0dBu einmessen.

Summenausgang:

- Testsignal wie oben einspeisen und Eingangsfader in Position '0dB' bringen.
- Entsprechende Summe anwählen (Bus Selector) und Summen-Fader ebenfalls auf 0dB positionieren.
- Voltmeter am Summenausgang anschliessen und Kanal 1 mit R152 (bzw. Kanal 2 mit R352) auf **Nennpegel** (+6dBu) einstellen.
- Danach bei der Eingangseinheit den nächsten Summenkanal anwählen und sinngemäss einstellen. Alle Summenregler auf diese Weise abgleichen.

Klirrabgleich:

Ein Klirrabgleich erübrigt sich, da die Ausgangsstufe klirrkompensiert ist.

Anmerkung:

- Bauteile des ersten Kanals (Print Nr. 1.911.323) haben Positions-Nummern von 100 bis 299, die des zweiten Kanals (Print Nr. 1.911.324) von 300 bis 499.
- Die beiden Kanäle der Stereo - Ausführungen sind baugleich und vollständig getrennt. Die Prints verhalten sich jedoch spiegelsymmetrisch zueinander.

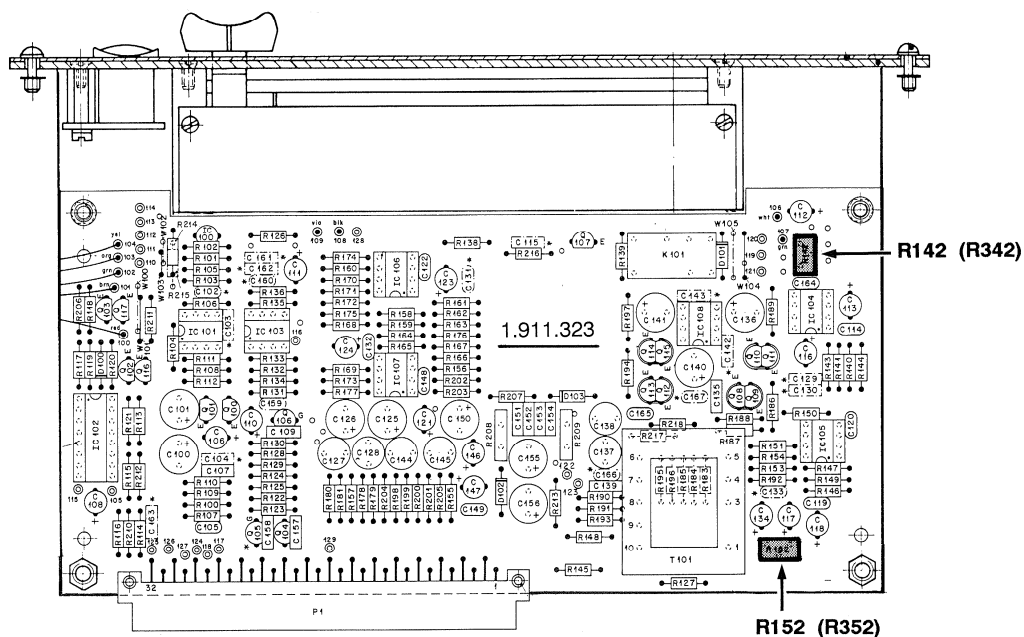

Fig. 6 Abgleichelemente der Master Unit MkII (Kanal 2 in Klammern)

Kanal 1: (Σ1, 3, 5..)	R142: AF-Insert OUT	R152: Pegel Summenausgang
Kanal 2: (Σ2, 4, 6..)	R342: AF-Insert OUT	R352: Pegel Summenausgang

3. Abgleichanleitungen Input-Panel

Die einzumessende Eingangseinheit ausbauen und die Printstecker P3, P4 sowie P6 mit Verlängerungskabeln anschliessen. Den Abgleich nur bei linearer Einstellung vornehmen. (Filter, EQ, BAL, PAN, Ø, Limiter ausschalten).

Alle Pegelangaben basieren auf einem **Nennpegel von +6dBu**. Vergleiche dazu die Abschnitte 1.1 "Pegeldefinitionen" und 1.6 "Messgrundlagen".

3.1 Eingangseinheiten Mono "A"

1.912.220...226

- Voltmeter an **PF-Insert** anschliessen. (unter Handauflage; Patch Panel bzw. P6-27) Richtiger Anschluss siehe oben. (1.7 "Messaufbau")
- Beide Filter ausschalten.
- Entzerrer mit Taste **EQUALIZER** ausschalten.

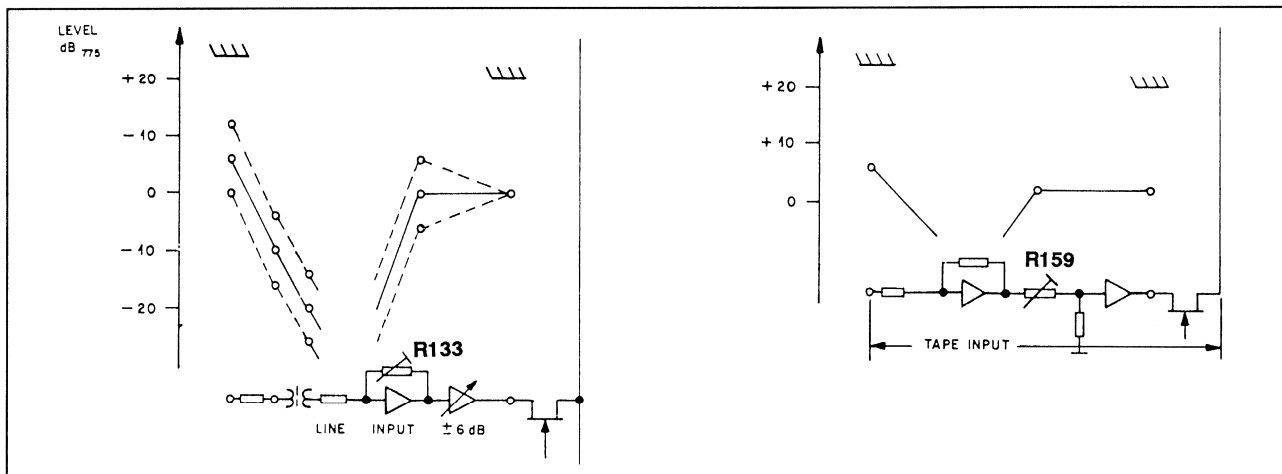

Fig. 7

Line Eingang:

- Testsignal mit Nennpegel in Line Eingang einspeisen.
- Korrektur-Potentiometer LINE GAIN in Kalibrierstellung einrasten.
- Pegel mit **R133** auf **0dBu** abgleichen.

Tape Eingang:

- Testsignal mit Nennpegel in Tape Eingang einspeisen.
- Pegel mit **R159** auf **0dBu** abgleichen.

Gleichtaktunterdrückung:

- Am elektronisch symmetrierten Tape Eingang kann die Gleichtaktunterdrückung abgeglichen werden. Das Testsignal auf die beiden Tonadern des Eingangs schalten, wie in Fig. 8 gezeigt.

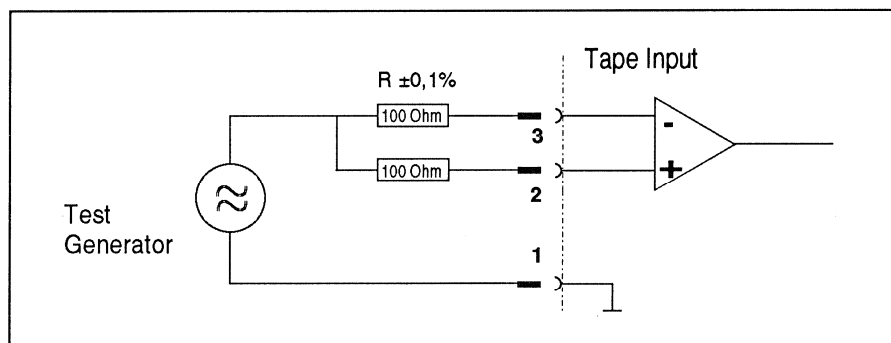

Fig. 8 Einspeisung des Testsignals zum Abgleich der Gleichtaktunterdrückung.

- Den Pegel am PF Insert mit **R153** auf **Minimalwert** einstellen.
 (Gleichtaktunterdrückung bei 1kHz/+6dBu \geq 80dB d.h. Messwerte im μ V-Bereich.)

Mikrophon Eingang: Für den Mikrophoneingang sind keine Einstellungen erforderlich. Entmagnetisierung des Eingangsübertragers vgl. 1.8.

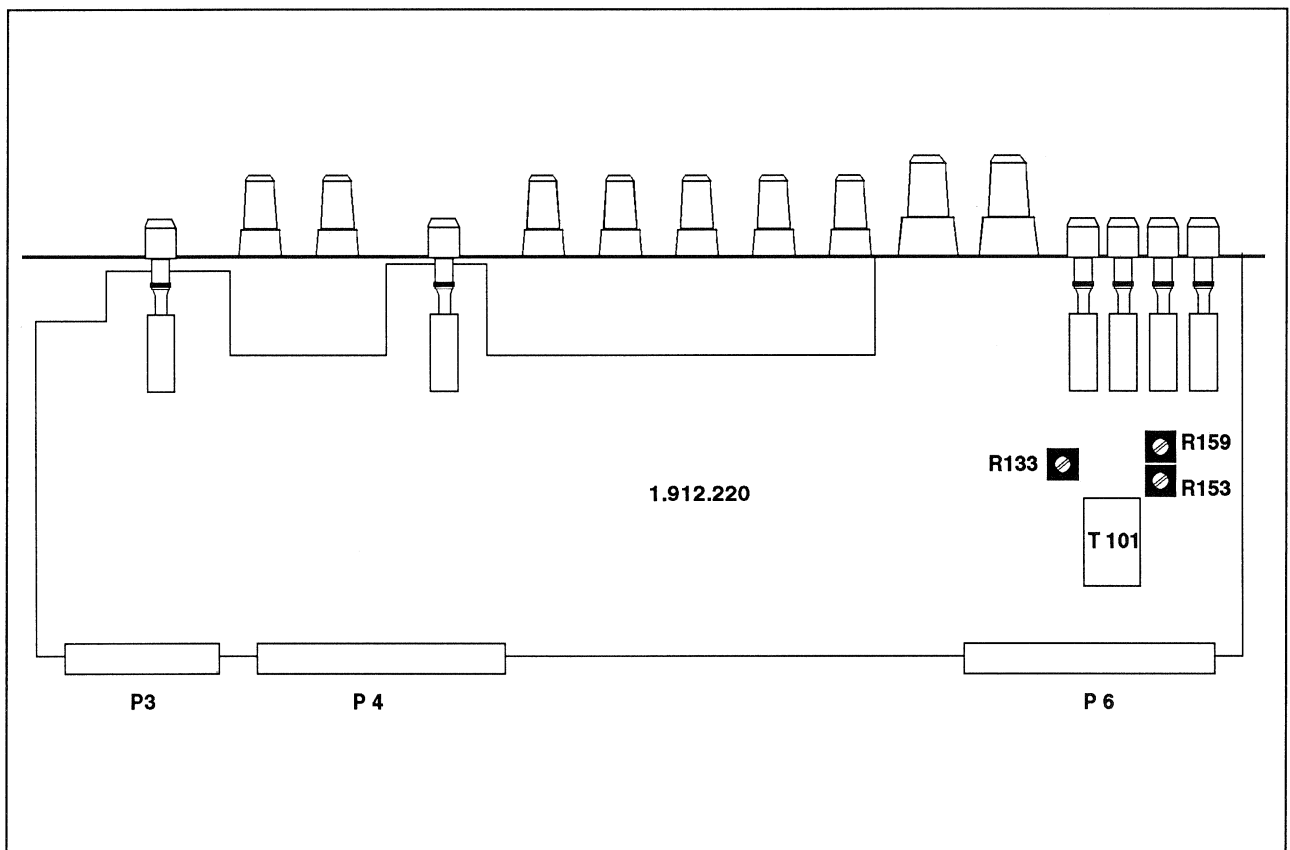

Fig. 9 Abgleichelemente der Mono Eingangseinheiten Version "A"

3.2 Eingangseinheiten Stereo Hochpegel "A"

1.912.240...243

Die beiden Line Eingänge benutzen die gleiche Eingangsstufe. Es genügt also, einen der Eingänge einzumessen.

- Potentiometer GAIN in Mittelstellung einrasten.
- MONO Taste, STEREO SPREAD und EQUALIZER ausschalten.
- Eingangswahltaste LINE 1 drücken.

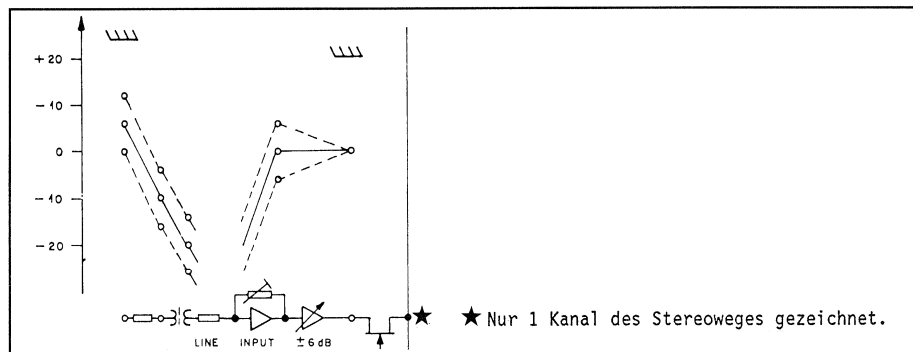

Fig. 10

Line Eingang links:

- Testsignal mit Nennpegel in Eingang LINE 1 (links) einspeisen.
- Voltmeter an **PF-Insert left** (Patch bzw. P3-15) anschliessen.
- Linken Kanal mit Trimmer **R114** auf **0dBu** abgleichen.

Line Eingang rechts:

- Testsignal mit Nennpegel in Eingang LINE 1 (rechts) einspeisen.
- Voltmeter an **PF-Insert right** (Patch bzw. P3-13) anschliessen.
- Rechten Kanal mit Trimmer **R214** auf **0dBu** abgleichen.

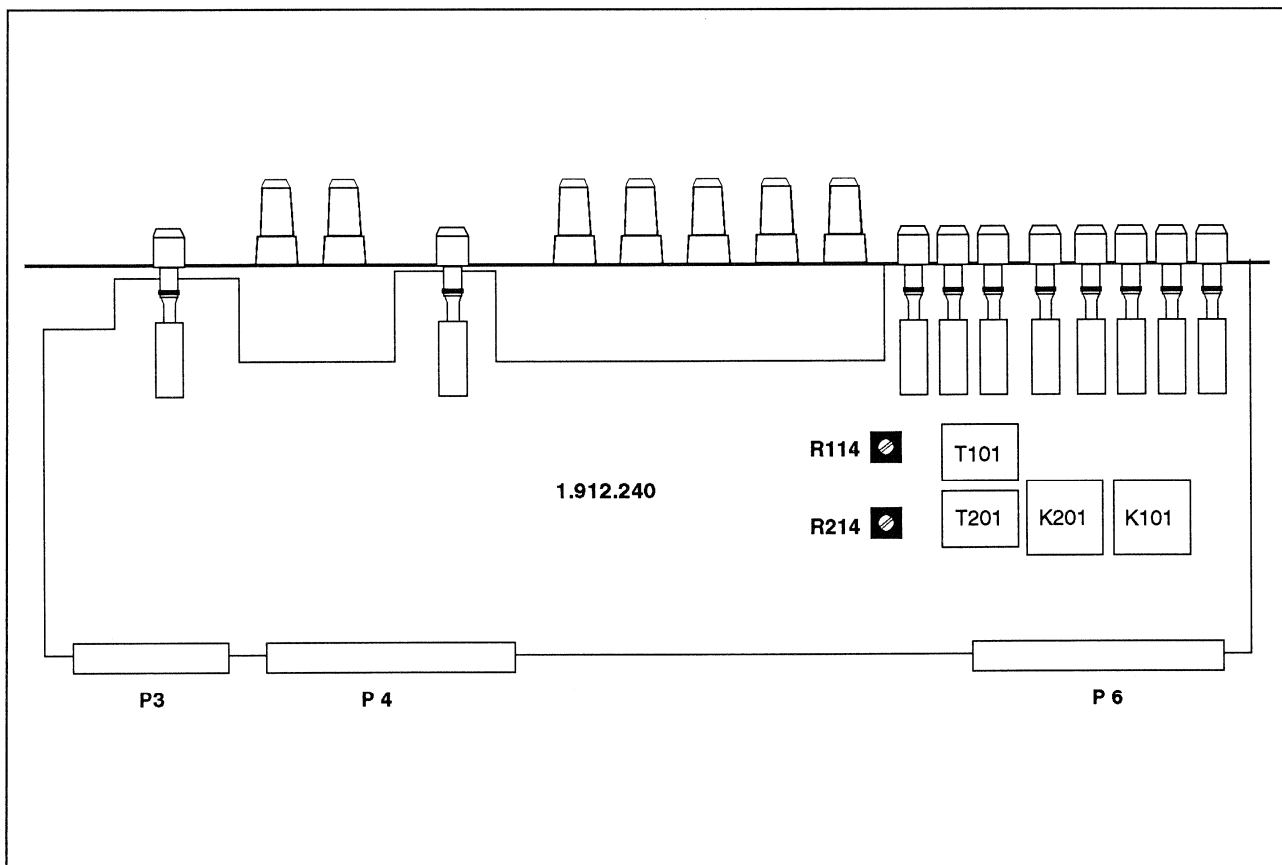

Fig. 11 Abgleichelemente der Eingangseinheiten Stereo Hochpegel Version "A".

3.3 Eingangseinheiten Stereo Universal "A"

1.912.250...253

- FILTER, EQUALIZER und STEREO SPREAD ausschalten.

Line Eingang:

- Potentiometer LINE GAIN in Mittelstellung einrasten.
- Eingang LINE anwählen.
- linker Kanal**
 - Testsignal mit Nennpegel in Eingang LINE links einspeisen.
 - Voltmeter an **PF-Insert left** (Patch bzw. P3-15) anschliessen.
 - Linken Kanal mit Trimmer **R125** auf **0dBu** abgleichen.
- rechter Kanal**
 - Testsignal mit Nennpegel in Eingang LINE rechts einspeisen.
 - Voltmeter an **PF-Insert right** (Patch bzw. P3-13) anschliessen.
 - Rechten Kanal mit Trimmer **R325** auf **0dBu** abgleichen.

Mikrophon Eingang:

Für den Mikrophoneingang sind keine Einstellungen erforderlich. Entmagnetisierung des Eingangsübertragers vgl. 1.8.

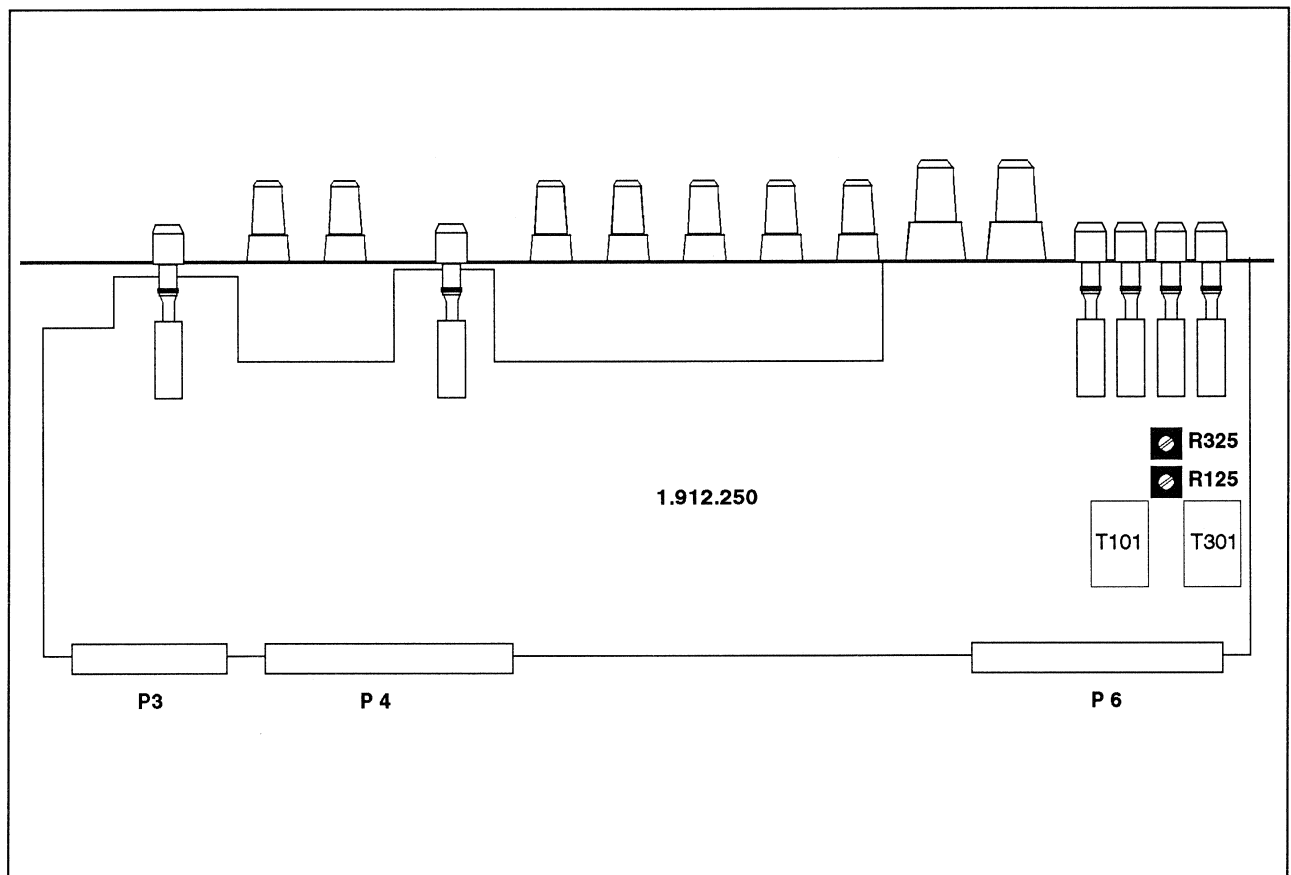

Fig. 12 Trimmer für den Abgleich des Line-Eingangs.

3.4 Eingangseinheiten Mono "B"

1.912.120/122

- EQUALIZER und FILTER ausschalten

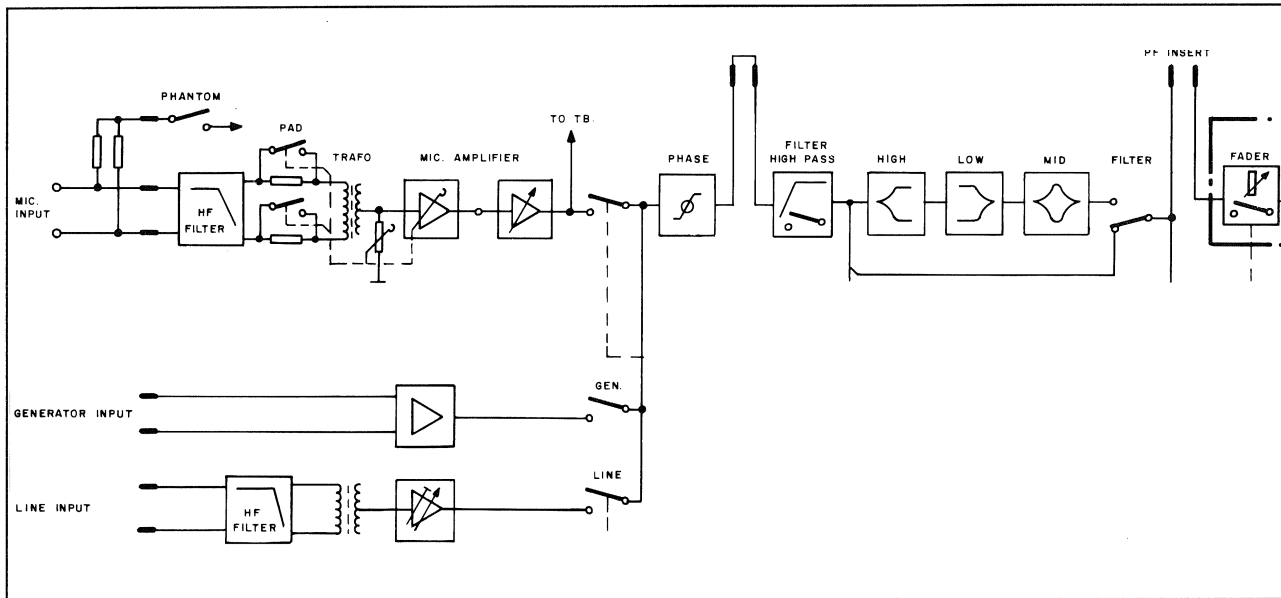

Fig. 13 Blockschaltbild

Line Eingang:

Als einzige Einstellung muss bei dieser Einheit der Pegel des Line Eingangs abgeglichen werden.

- Testsignal mit Nennpegel in LINE Eingang einspeisen.
- Korrektur-Potentiometer LINE GAIN in Kalibrierstellung einrasten.
- Voltmeter an PF-Insert (Patch bzw. P6-27) anschliessen.
- Pegel mit R35 auf 0dBu abgleichen.

Übrige Eingänge:

Die Eingänge für Mikrophon und Generator brauchen keine Pegelanpassung.

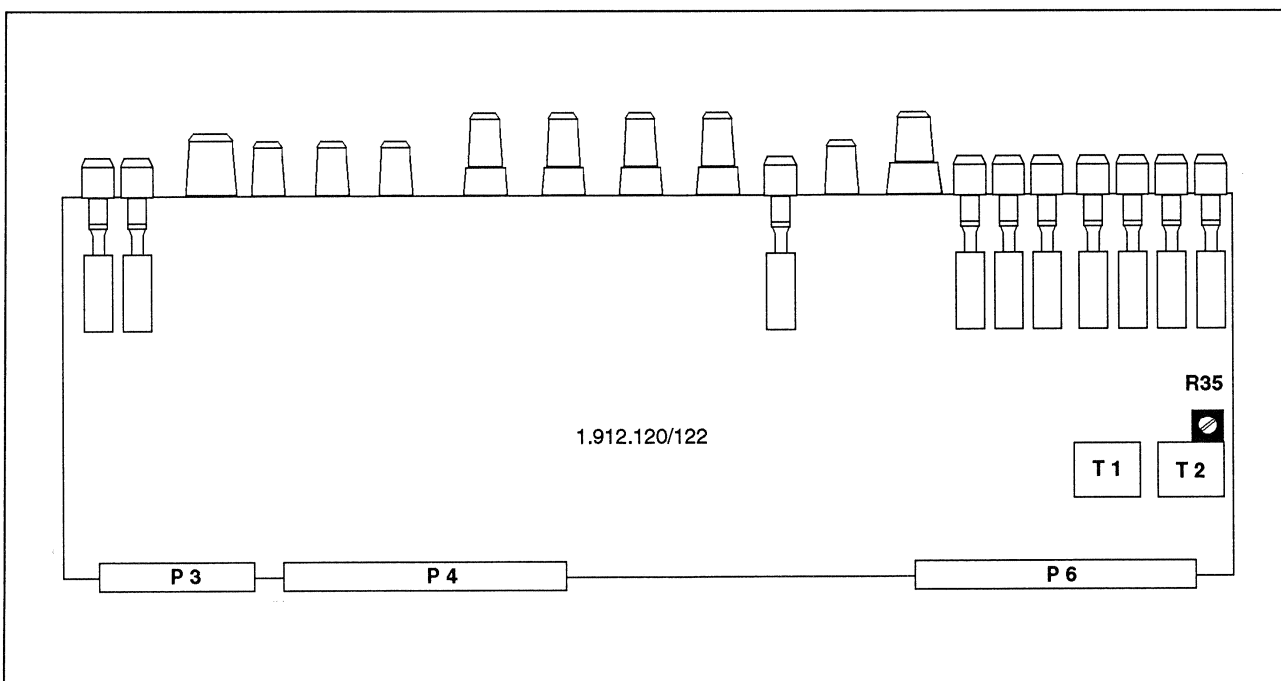

Fig. 14 Abgleich Elemente der Mono Eingangseinheiten Version "B".

3.5 Eingangseinheiten Stereo Hochpegel "B"

1.912.141...145

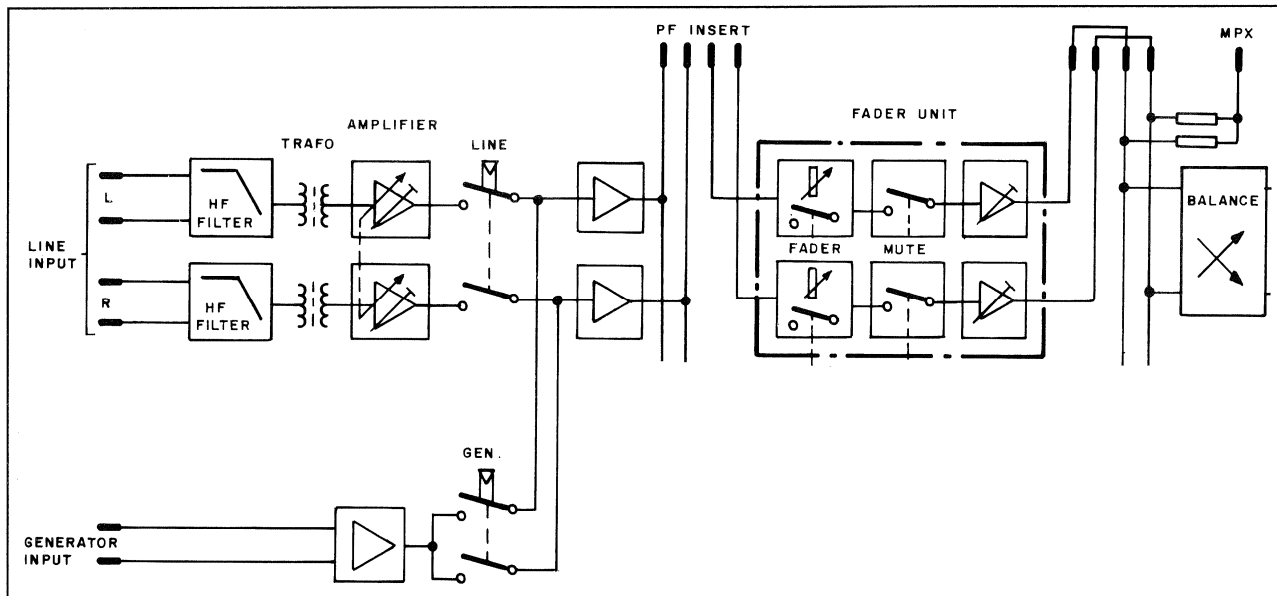

Fig. 15 Blockschaltbild

Line Eingang:

- Testsignal mit Nennpegel in LINE Eingang einspeisen.
- Korrektur-Potentiometer LINE GAIN in Kalibrierstellung einrasten.

linker Kanal

- Voltmeter an PF-Insert left (Patch bzw. P3-15) anschliessen.
- Pegel mit R109 auf 0dBu abgleichen.

rechter Kanal

- Voltmeter an PF-Insert right (Patch bzw. P3-13) anschliessen.
- Pegel mit R209 auf 0dBu abgleichen.

Generator:

Der Generator-Eingang braucht keinen Pegelabgleich.

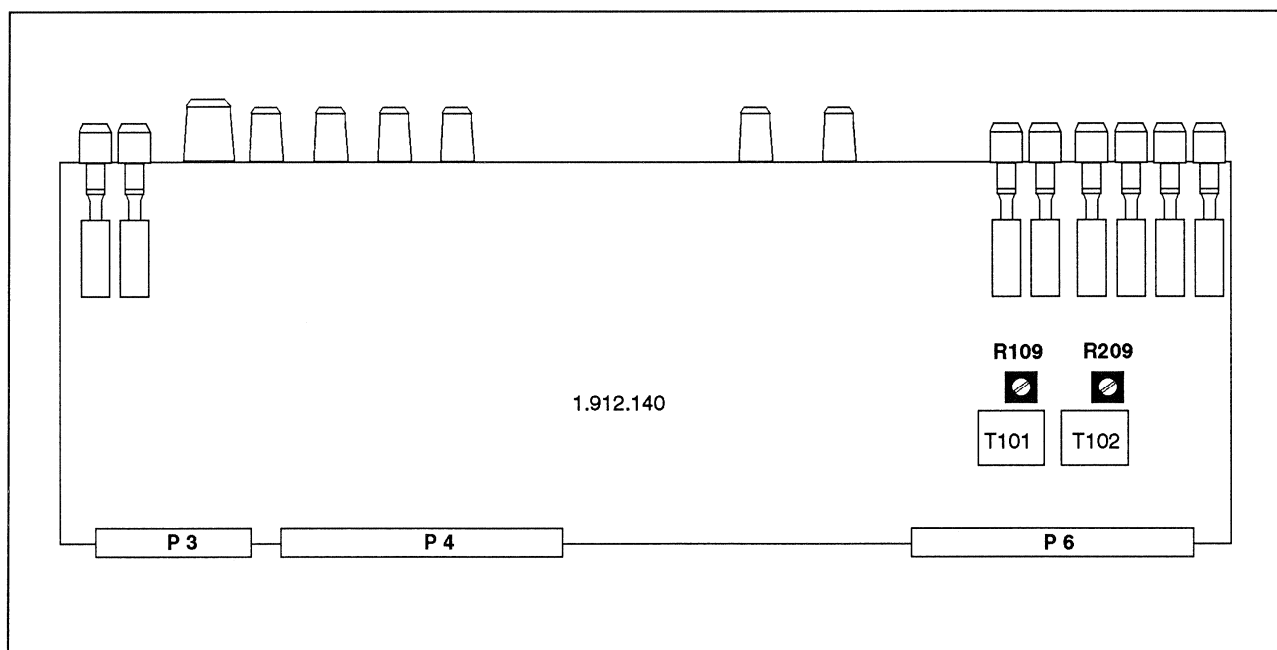

Fig. 16 Abgleich Elemente der Stereo Eingangseinheiten Version "B".

3.6 Auxiliary Mastereinheit

1.912.310

- AUX-Ausgangspegel:** Die Ausgangspegel der Hilfssummen AUX werden bei Maximalverstärkung im Hilfsweg auf **10dB über dem Nennpegel** abgeglichen.
- Testsignal mit **Nennpegel** in LINE Eingang 1 einspeisen und Eingangsfader auf 0dB positionieren.
 - **AUX**-Regler des Eingangs in Stellung **AF** auf Rechtsanschlag öffnen. ☉
 - Die Regler AUX SEND (1...4) der AUX Master Einheit ebenfalls ganz öffnen. ☉
- AUX 1 ...3**
- Voltmeter an den jeweiligen AUX-Ausgang anschliessen.
 - Pegel mit Brückenstecker (0dB/-10dB) und Trimmer auf 10dB über dem Nennpegel abgleichen. Die zu den jeweiligen Hilfswegen gehörenden Abgleichelemente **A** und **Z** sind unten dargestellt.
- AUX 4**
- Einstellvorgang wie oben beschrieben durchführen.
 - AUX-Balanceregler (Eingangseinheit) extrem **links** einstellen und Ausgangspegel AUX 4 links mit **R425** auf 10dB über Nennpegel einmessen.
 - AUX-Balanceregler (Eingangseinheit) extrem **rechts** einstellen und Ausgangspegel AUX 4 rechts mit **R525** auf 10dB über Nennpegel einmessen.
- Klirrabgleich:** Diese Einstellung ist nur nach Reparatur einer Ausgangsstufe notwendig.
- Voltmeter an AUX Ausgang anschliessen.
 - 30Hz Sinuston vom Generator auf die zu messende Hilfssumme schalten.
 - Testsignal auf einen Ausgangspegel von +24dBu erhöhen und mit den unten angegebenen Trimpotentiometern auf minimalen Klirr abgleichen.

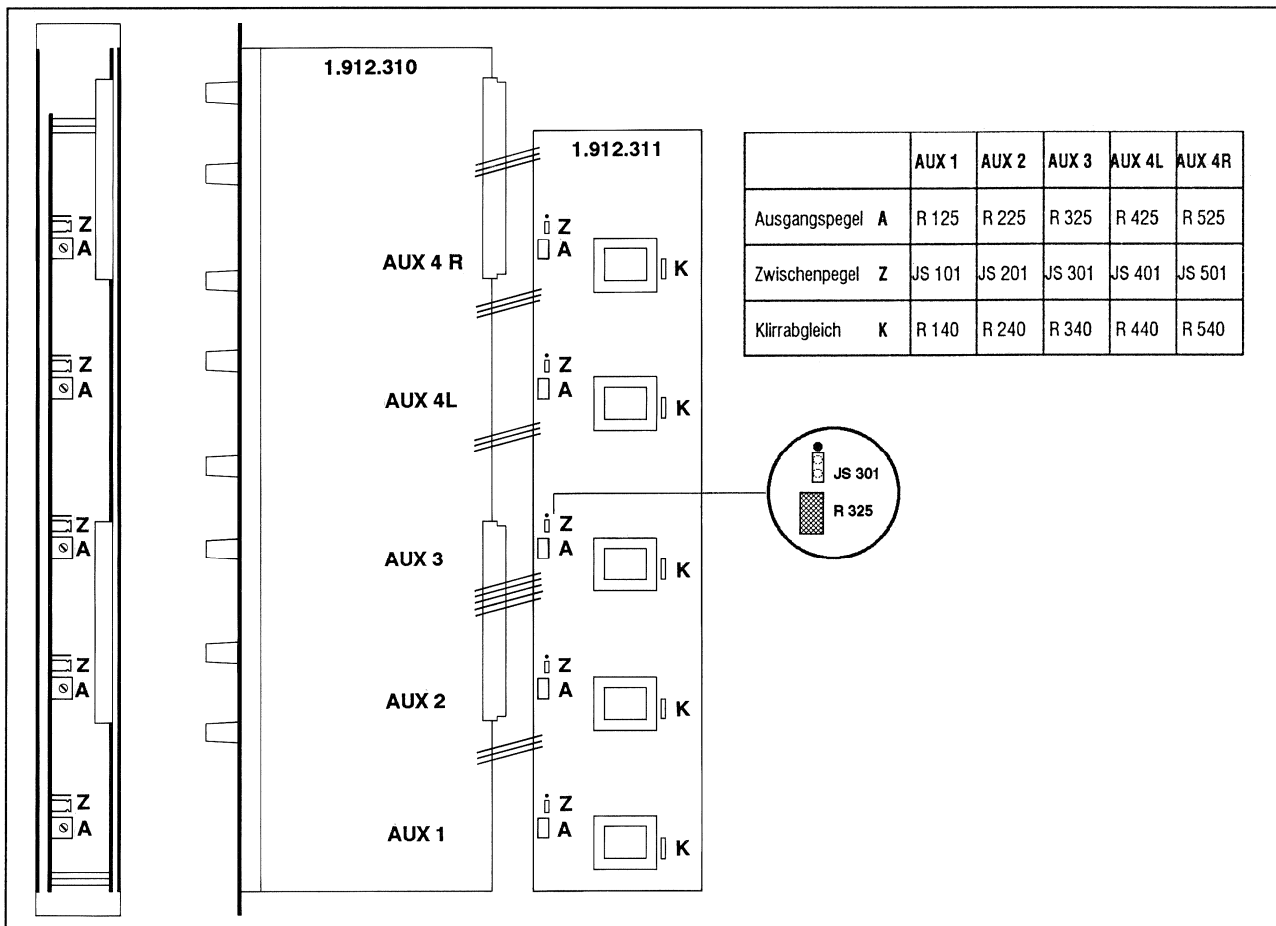

Fig. 17 Abgleichelemente der AUX Master Einheit.

3.7 Kontrollraum Monitor

1.912.420

Für den Abgleich darf keine Taste der Einheit gedrückt (d.h. aktiviert) sein.

- Testsignal mit Nennpegel in Eingang EXTERNAL 1 links bzw. rechts einspeisen.
- Den Eingang EXT 1 auf CR Monitor anwählen.
- Monitor VOLUME Potentiometer auf Rechtsanschlag öffnen C.
- BALANCE Regler mit Taste BALANCE IN ausschalten.

Kopfhörer Pegel:

- Voltmeter ohne Last mit einem 6,3mm Jack-Stecker an eine der Kopfhörerbuchsen anschliessen:
Spitze = linker Kanal / Ring = rechter Kanal / Schaft = 0V
- Pegel mit R7 links bzw. R64 rechts auf +20dBu (7,75V) abgleichen.

CR Monitor:

- Voltmeter ohne Last an CR MONITOR Ausgang links bzw. rechts anschliessen.
- Ausgangspegel mit R30 links, bzw R82 rechts auf +16dBu abgleichen.

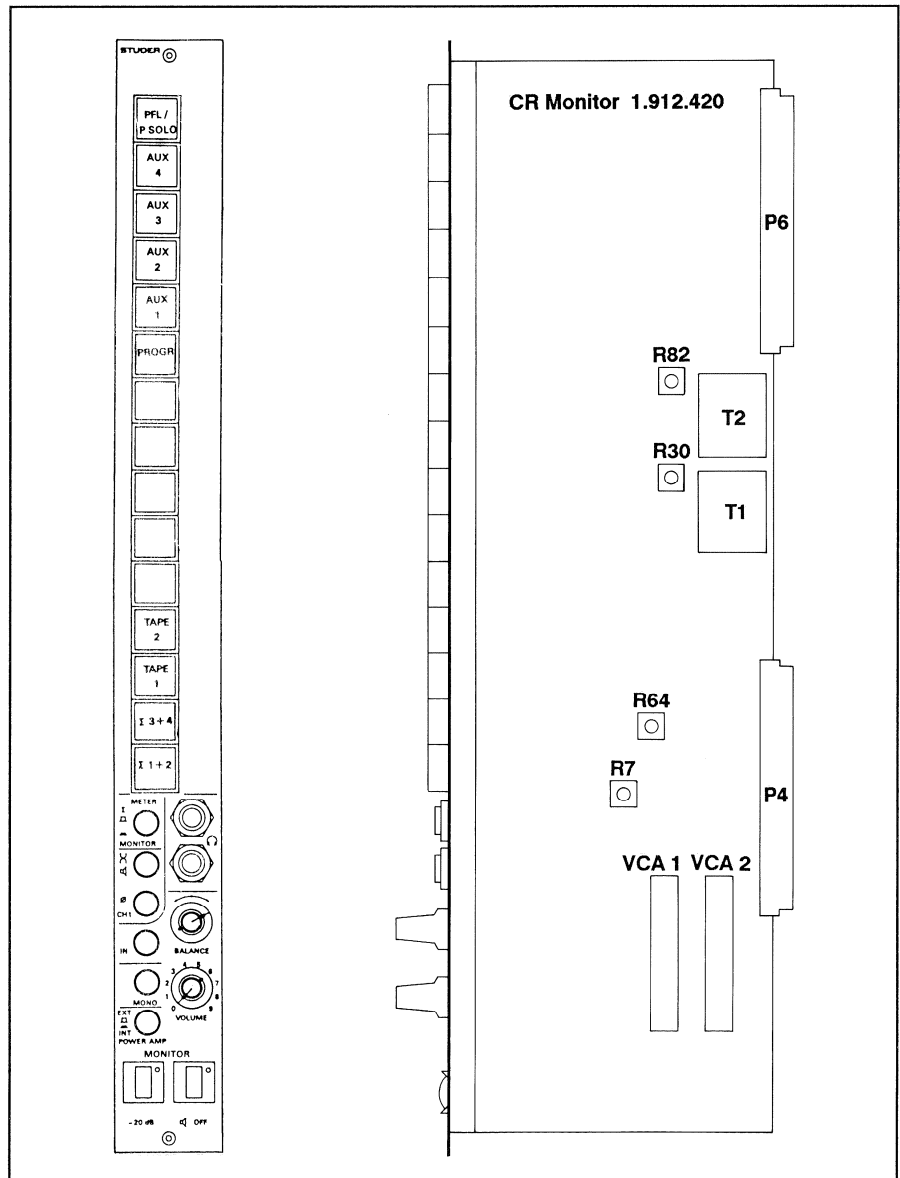

Fig. 18 Abgleich Elemente der Kontrollraum-Monitorereinheit 1.912.420.

3.8 Studio Monitor und Kommando-Einheit

1.912.320

Vor dem Einmessen des Studio Monitors muss der Kontrollraum Monitor korrekt abgeglichen sein.

PFL - Pegel:

- Das Testsignal mit **Nennpegel** in LINE Eingang (Gain: CAL) der Eingangseinheit 1 einspeisen.
- **PFL**-Taste dieses Eingangskanals drücken.
- Monitor VOLUME des Kontrollraum Monitors auf Rechtsanschlag öffnen ☉.
- Taste PFL/P.SOLO to MONITOR des Studio Monitors drücken. Das Testsignal wird vor dem PFL/P.SOLO-Regler des Studio Monitors abgegriffen und auf den CR MONITOR Ausgang geschickt.

PFL/P.SOLO-Monitor

- Voltmeter ohne Last an den CR MONITOR Ausgang anschliessen.
- Abgleich mit **R67** links bzw. mit **R70** rechts auf **+16dBu**.

PFL/P.SOLO-Kopfhörer

- Potentiometer PFL/P.SOLO auf Rechtsanschlag öffnen ☉.
- Voltmeter ohne Last an Kopfhörerbuchse PFL/P.SOLO anschliessen.
Spitze = linker Kanal / Ring = rechter Kanal / Schaft = 0V
- Mit **R79** links bzw. mit **R87** rechts auf **+20dBu** abgleichen.

Hinweise:

- Der Studio Monitor wird stummgeschaltet, wenn ein Mikrophonsignal durchgeschaltet ist. Dies wird durch die CUT-LED angezeigt. Mit der Taste RE-IN kann die Stummschaltung aufgehoben werden.
- Die Tasten TB STUDIO und TB SPEAKER senken den Pegel des STUDIO-Ausganges um 20dB und dürfen daher nicht aktiviert sein.

Studio Monitor:

- Testsignal mit **Nennpegel** in einen Monitoreingang EXTERNAL einspeisen und die entsprechende Quellenwahltaste in der Sektion STUDIO drücken.
- Potentiometer STUDIO auf Rechtsanschlag öffnen ☉.
- Voltmeter ohne Last an STUDIO-Ausgang links bzw. rechts anschliessen.
- Mit **R11** links bzw. mit **R32** rechts auf **+16dBu** abgleichen.

Studio Kopfhörer:

- Diese Einstellung betrifft den Pegel, mit welchem das Studio Monitor Signal zum Studio-Kopfhörer gesendet wird. (Anschluss z.B. an Talk Back Box)
- Testsignal wie für den Studio Monitor beschrieben einspeisen.
 - Voltmeter ohne Last an den Ausgang TB-Box (D-Typ) oder an die Kopfhörerbuchse der TB-Box (VOLUME ganz öffnen!) anschliessen.
(Spitze = linker Kanal / Ring = rechter Kanal / Schaft = 0V)
 - Mit **R7** links bzw. mit **R28** rechts auf **+20dBu** abgleichen.

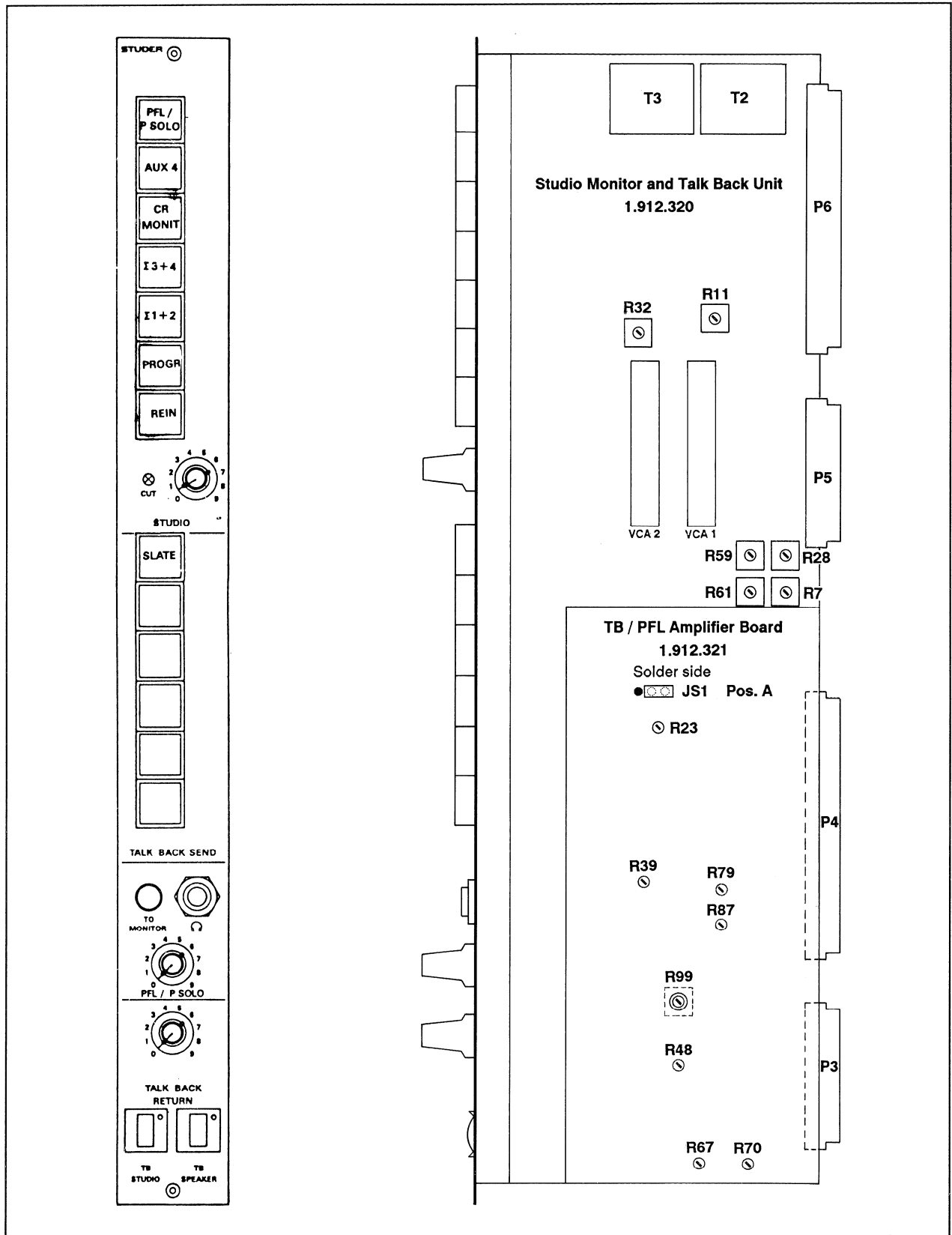

Fig. 19 Abgleichelemente der Studio Monitor und Kommando-Einheit 1.912.320.

EINMESSEN

Talk Back Pegel:

Das Gegensprechmikrofon des Kontrollraums wird mit drei Trimmern eingestellt: Eingangsverstärkung, Einspeisung auf Studio Monitor und auf Studio Kopfhörer getrennt.

- In die Mikrofonbuchse am Mischpult (Schwanenhals) das **Testsignal mit -60dBu** einspeisen. Anschluss symmetrisch an Pin 1 und 3 des DIN-Steckers.

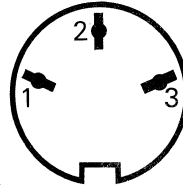

TB-Mikrofon (Kontrollraum)

- Taste TB SEND A drücken.
- Voltmeter ohne Last an TB EXTERNAL Ausgang 1 anschliessen.
- Abgleich der Limiterschwelle des TB-Weges mit **R99** auf **+6dBu**. Der Trimmer ist durch eine Bohrung in der Platine 1.912.321 zugänglich. (Der Jumper JS1 (1.912.321) soll auf Position A gesetzt sein.)

TB auf Studio Monitor

- Impulstaste TB STUDIO betätigen.
- Voltmeter ohne Last an linken Kanal des STUDIO-Ausgangs anschliessen.
- Mit **R59** auf **+6dBu*** abgleichen. (Trimmer R59 wirkt auf beide Kanäle)
* = Werkeinstellung. Pegel abhängig von gewünschter TB-Lautstärke.

TB auf Studio Kopfhörer

- Voltmeter ohne Last an den Ausgang TB-Box (D-Typ) oder an die Kopfhörerbuchse der TB-Box (VOLUME ganz öffnen!) anschliessen. (Spitze = linker Kanal / Ring = rechter Kanal / Schaft = 0V)
- Pegel mit **R61** auf **+6dBu*** einstellen. (Trimmer R61 wirkt auf beide Kanäle.)
* = Werkeinstellung. Pegel abhängig von gewünschter TB-Lautstärke.

TB Return

- **Testsignal** mit **+6dBu** in TB RETURN Eingang einspeisen.
- Dieses Signal wird von der TB-Signalisation zum PFL/TB-Lautsprecher durchgeschaltet. Von extern muss daher eine TB-Taste gedrückt werden. (Das interne Signal 'E' öffnet den TB RET-Weg. Schema 1.912.320; Seite 2)
- Potentiometer TB RETURN ganz öffnen ☉.
- Einstellung TB RETURN INPUT mit **R48** auf gewünschte Maximallautstärke.

Dämpfung TB Return

Das TB-Signal des Sprechers könnte über das TB-Mikrofon im Kontrollraum rückgekoppelt werden. Aus diesem Grund wird der TB Return gedämpft, sobald im Kontrollraum eine TB-Taste gedrückt wird. R39 bestimmt das Mass dieser Dämpfung.

- **Testsignal** mit **-60dBu** in die Buchse des Sprecher TB-Mikrophons einspeisen. (D-Typ)
- Eine TB-Taste auf dem Pult drücken. Die dadurch eingeschaltete Dämpfung des TB Returns mit **R39** auf gewünschten Wert einstellen.
Werkeinstellung: **-20dB**.
(Das interne Signal 'D' dämpft den TB RET-Weg. Schema 1.912.320; Seite 2)

Sprecher TB-Mikrofon

- Testsignal und Messanordnung wie für die Dämpfung des TB Returns beibehalten.
- Gleich wie beim TB RETURN muss die Signalisation aktiviert sein. (s.o.)
- Potentiometer TB RETURN ganz öffnen ☉.
- Einstellung SPEAKER MIC mit **R23** auf gewünschte Maximallautstärke.

4. Abgleichanleitungen Instrumenten Panel

4.1 PPM-Zeigerinstrumente

1.913.220/221

- Testsignal mit Nennpegel zum Summenausgang durchschalten..
- Mit **R4** (Fig. 20) am zugehörigen Instrument den Zeigerausschlag auf 0dB einstellen.

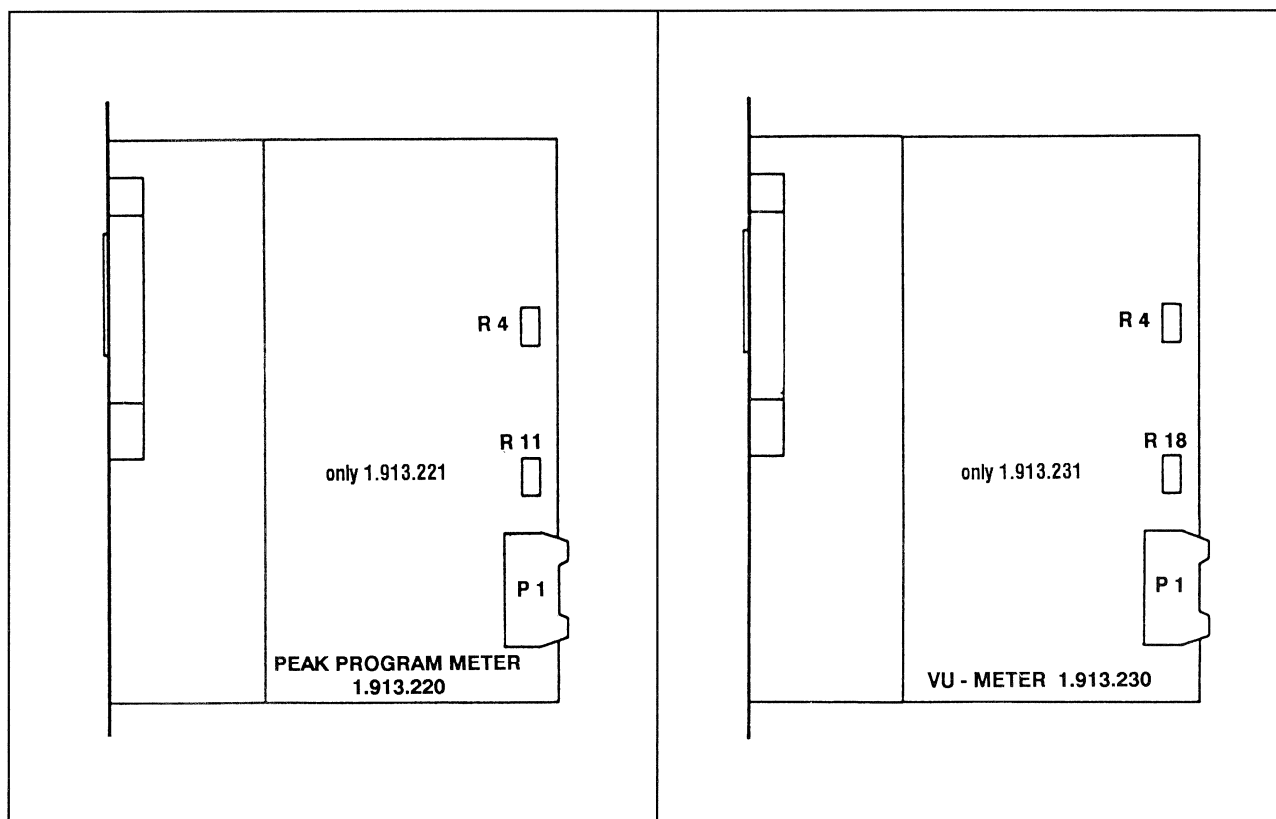

Fig. 20 Abgleich des PPM

Fig. 21 Abgleich des VU-Meters

4.2 VU-Zeigerinstrumente

1.913.230/231

- Testsignal am Summenausgang Pegel auf **Nennpegel minus 'Lead'** (=Vorlauf des VU-Instruments, vgl. 1.6) einstellen.
- Mit **R4** (Fig. 21) am zugehörigen Instrument Zeigerausschlag auf **0VU** einstellen. Damit ist der notwendige Vorlauf von beispielsweise 6dB eingestellt.

4.3 Korrelator 2CH / 4 CH

1.913.210/211

- Testsignal mit Nennpegel zu beiden Kanälen einer Stereosumme durchschalten.
- Spannung an Testpunkt 1 (TP1) mit R4 bzw. an Testpunkt 2 (TP2) mit R13 auf **-18dBu** (100mV AC) abgleichen.
- Das einkanalige Testsignal (Mono) ist auf die Stereosumme aufgeschaltet. Beide Summenkanäle sind darum phasengleich korreliert. Mit R26 Zeigerausschlag des Korrelators auf +1 einstellen.

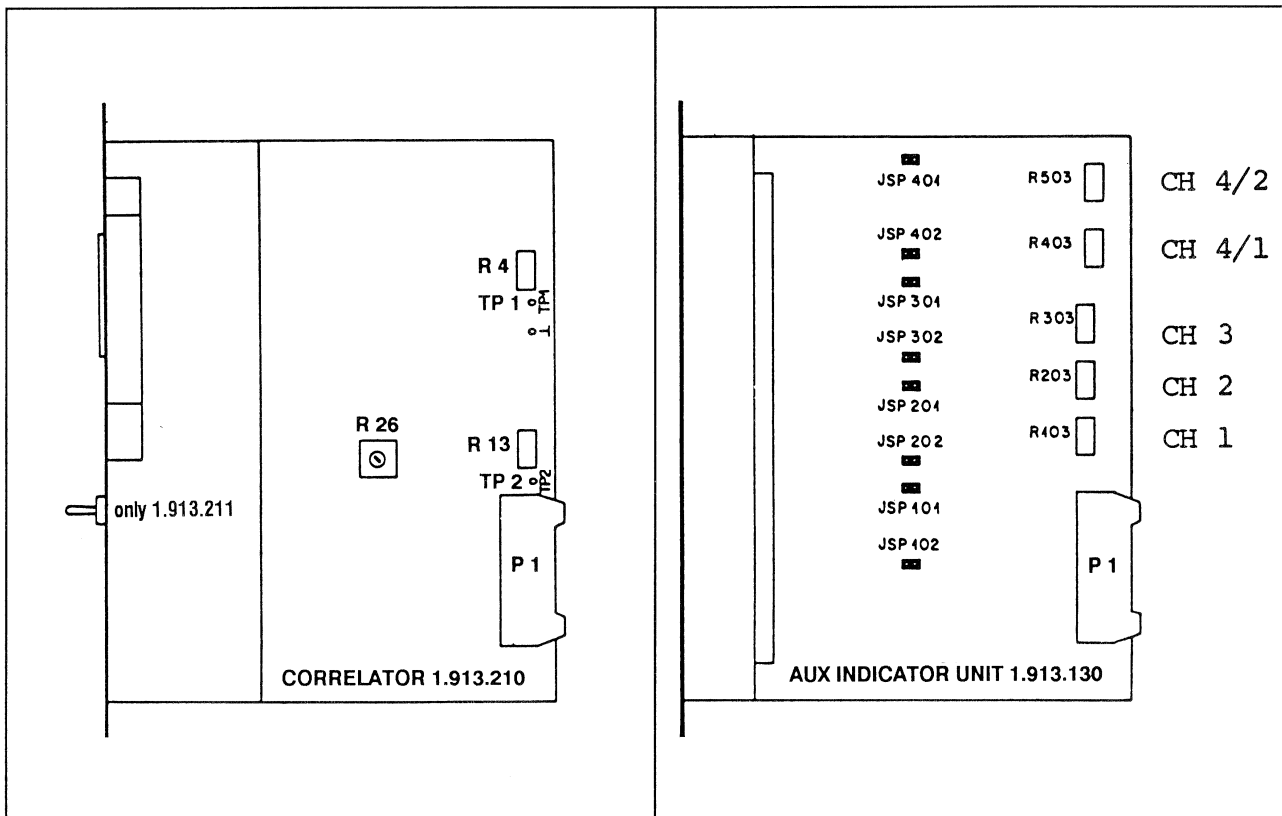

Fig. 22 Abgleich des Korrelators

Fig. 23 Abgleich des AUX-Instruments

4.4 AUX-Anzeigeeinstrumente VU / PPM

1.913.130

Auf dieser Einheit befinden sich die vier Instrumente der Hilfsausgänge. Die Anzeige-Charakteristik kann den Hauptinstrumenten angepasst werden. Es ist eine Wahl zwischen PPM und VU möglich. Die Wahl wird mit Brückensteckern (Jumpers) vorgenommen. Diese Punkte sind mit JSP bezeichnet. (Fig. 23).

VU-Charakteristik:

Die Jumper müssen wie folgt gesetzt sein:

JSP 102 → Instrument AUX 1
 JSP 202 → Instrument AUX 2
 JSP 302 → Instrument AUX 3
 JSP 402 → Instrument AUX 4

VU-Meter:

Einstellung für Spitzenpegel (Peak Level) +10 dBu / +12 dBu.
 Für diese beiden Spitzenpegel liegt der Pegel für eine 0VU-Anzeige bei +4 dBu.
 Der Vorlauf (Lead) beträgt also 6dB resp. 8dB.

AUX 1...3 (VU)

Testsignal mit **+4dBu** an den Eingang des jeweiligen Instrumentes anlegen.
 Einstellen der Anzeige auf **0VU** mit Trimmer CH1 ... CH3. (siehe Fig. 23)

AUX 4 (VU)

AUX 4 zeigt die **Monosumme** des Stereohilfsweges an. Jeder Kanal einzeln wird auf eine Anzeige von **-3VU** eingestellt. Beide Kanäle zusammen ergeben dann 0VU.

- +4dBu an **AUX 4/1** (linker Kanal), kein Pegel an AUX 4/2.
 ■ Mit Trimmer CH 4/1 auf -3VU-Anzeige einstellen.
- +4dBu an **AUX 4/2** (rechter Kanal), kein Pegel an AUX 4/1.
 ■ Mit Trimmer CH 4/2 auf -3VU-Anzeige einstellen.

PPM-Charakteristik:

Für den Betrieb als Peak Program Meter gelten folgende Jumper-Einstellungen:

JSP 101 → Instrument AUX 1
 JSP 201 → Instrument AUX 2
 JSP 301 → Instrument AUX 3
 JSP 401 → Instrument AUX 4

AUX 1...3 (PPM)

Nennpegel an den Eingang der Instrumente anlegen.
 Einstellen mit Trimmer CH1...CH3 auf Anzeige **0dB**.

AUX 4 (PPM)

Dieser Stereo-Hilfsweg wird prinzipiell gleich eingestellt, wie beim VU-Instrument beschrieben.

- **Nennpegel** an **AUX 4/1** (linker Kanal), kein Pegel an AUX 4/2.
 ■ Mit Trimmer CH 4/1 auf **-3dB**-Anzeige einstellen.
- **Nennpegel** an **AUX 4/2** (rechter Kanal), kein Pegel an AUX 4/1.
 ■ Mit Trimmer CH 4/1 auf **-3dB**-Anzeige einstellen.

4.5 Testgenerator

1.913.150

- Oszillator:**
- Auf dem Testgenerator die Taste **OSCILLATOR** drücken und die Frequenz auf **1kHz** einstellen.
 - Voltmeter an symmetrischen Generatorausgang anschliessen: **P1-1 / P1-3**.
 - Mit **R49** Nennpegel einstellen.

- Klirrabgleich**
- Frequenz auf **30Hz** einstellen.
 - Mit **R59** Klirr auf **-62dB (0,08%)** abgleichen.

- Kennton:**
- Taste **IDENT** drücken.
 - Mit **R52** Nennpegel einstellen.

- Weisses Rauschen:**
- Taste **WHITE NOISE** drücken.
 - Mit **R67** Nennpegel einstellen.

- Rosa Rauschen:**
- Taste **PINK NOISE** drücken.
 - Mit **R73** Nennpegel einstellen.

Das Springen des Instrumenten-Zeigers bei den Rauschsignalen ist schaltungsbedingt und somit normal.

- Generatoreingang:**
- Auf Kanal 1 Eingang **GEN** wählen.
 - Voltmeter ohne Last an **PF-Insert** anschliessen.
 - Mit **R89** auf Insertpegel (vgl. 1.6) einstellen.

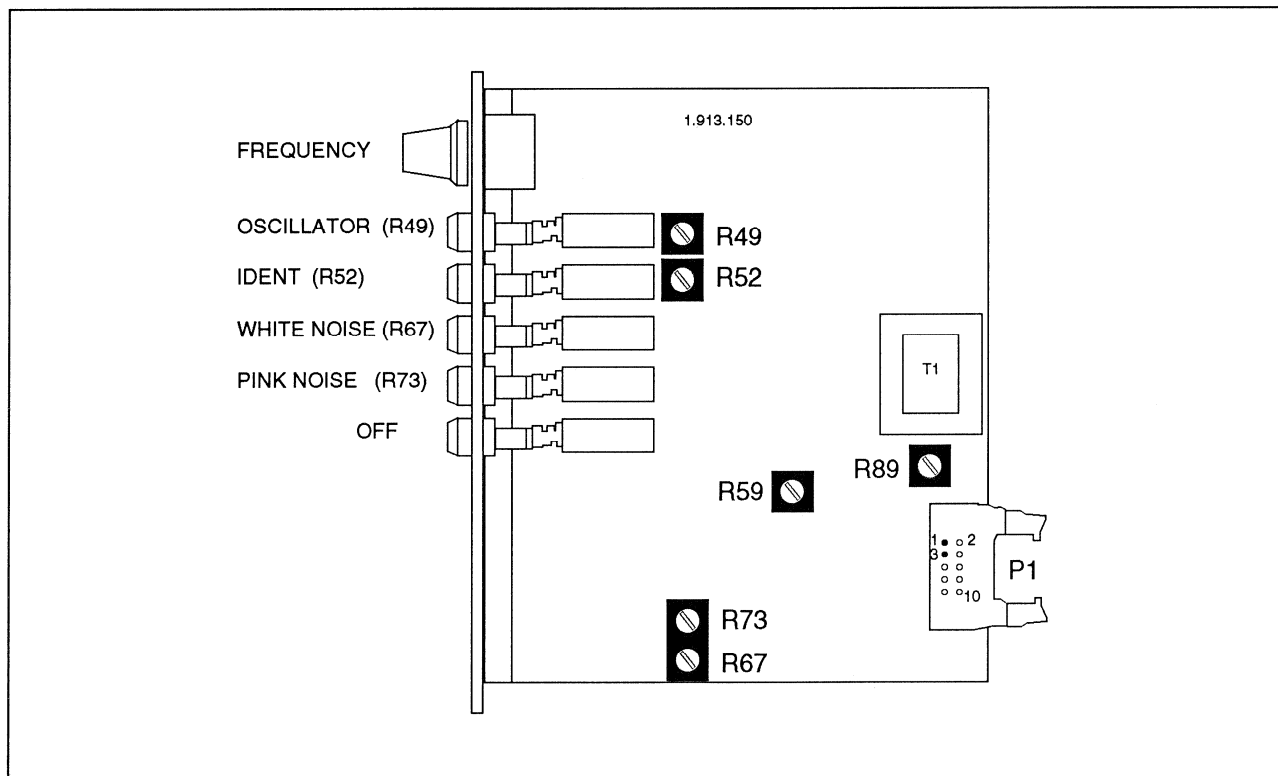

Fig. 24 Abgleich Elemente des Testgenerators 1.913.150.

SECTION 3: Alignment Instruction

CONTENTS

page

1. General 1

1.1 Level definition 1

1.2 Conversion table for voltage levels: volt ↔ dBu..... 2

1.3 Requirement for calibration..... 3

1.4 Required tools and utensils 3

1.5 Electrostatically Sensitive Elements "ESE".... 3

1.6 Calibration requirements..... 4

1.7 Measuring setup 5

1.8 Demagnetizing the Microphone Input Transformers 7

2. Units of the fader panel 8

2.1 Mono/stereo fader unit 1.911.110...122 ... 8

2.2 Master fader Mk II..... 1.911.315...335 ... 9

3. Units of the input panel 10

3.1 Input units mono "A"..... 1.912.220...226 10

3.2 Input units stereo high level "A" 1.912.240...243 12

3.3 Input units stereo universal "A" 1.912.250...253 13

3.4 Input units mono "B"..... 1.912.120/122 14

3.5 Input units stereo high level "B"..... 1.912.141...145 15

3.6 Auxiliary master unit 1.912.310..... 16

3.7 Control Room Monitor 1.912.420..... 17

3.8 Studio Monitor and Talk Back unit..... 1.912.320..... 18

4. Main Instruments..... 21

4.1 VU-Meter 1.913.230/231 ... 21

4.2 Peak Program Meter (PPM) 1.913.220/221 ... 21

4.3 Correlator 1.913.210/211 22

4.4 AUX Indicator 1.913.130..... 23

1. General

1.1 Level definition

Level specifications: The specifications of nominal levels in dBu are based on a fixed voltage as the reference value:

0 dBu \cong 0,775 V_{eff.}
--

The reference value of 0.775 V for the relative voltage level in dBu has been derived from the value definition of the absolute voltage level in dBm, however without regard to the definition (600Ω/1mW).

Nominal level in dBu: The nominal level corresponds to the studio level at peak level recording. The terms line level and studio level are used synonymously.

The typical nominal levels are::

+6dBu	\cong	1,55V _{eff.}
+10dBu	\cong	2,45V _{eff.}
+15dBu	\cong	4,36V _{eff.}

Output level:

0 dB PPM	=	Nominal level
0 VU	=	Nominal level minus 6 dB*

* 6dB correspond to the widely used value for the VU instrument lead.

PPM consoles Peak program meters as quasi-peak reading instruments indicate 0 dB at nominal level.

VU consoles VU-instruments indicate the level of a test signal plus the lead of the instrument. Therefore the test signal must be nominal level minus lead for a 0VU indication.

Gain/attenuation: The relative level specifications in dB provide information on the degree of amplification/attenuation of an active (e.g. amplifier) or passive (e.g. potentiometer) attenuation provided by an element with in a circuit. The following table translates the voltage ratios (output ÷ input) into decibel values (rounded factors):

		dB	0	1	2	3	6	10	14	20	26	34	40
Factor	Gain		1	1,1	1,2	1,4	2	3,2	5	10	20	50	100
	Attenuation		1	0,9	0,8	0,7	0,5	0,3	0,2	0,1	0,05	0,02	0,01

ALIGNMENT

1.2 Conversion table for voltage levels: volt ↔ dBu

$\frac{U_1}{U_2}$	$\frac{\mu V}{mV/V} \rightarrow dBu$				$\frac{U_1}{U_2}$	$\frac{\mu V}{mV/V} \rightarrow dBu$			
	μV	mV	V	dBu		μV	mV	V	dBu
1	0,775	±0	-60	-120	31,6	24,5	+30	-30	-90
1,12	0,87	+1	-59	-119	35,5	27,5	+31	-29	-89
1,26	0,98	+2	-58	-118	39,8	30,8	+32	-28	-88
1,41	1,09	+3	-57	-117	44,7	34,6	+33	-27	-87
1,59	1,23	+4	-56	-116	50,1	38,8	+34	-26	-86
1,78	1,38	+5	-55	-115	56,2	43,6	+35	-25	-85
2,00	1,55	+6	-54	-114	63,1	48,9	+36	-24	-84
2,24	1,73	+7	-53	-113	70,8	54,8	+37	-23	-83
2,51	1,95	+8	-52	-112	79,4	61,5	+38	-22	-82
2,82	2,18	+9	-51	-111	89,1	69,0	+39	-21	-81
3,16	2,45	+10	-50	-110	100	77,5	+40	-20	-80
3,55	2,75	+11	-49	-109	112	86,9	+41	-19	-79
3,98	3,08	+12	-48	-108	126	97,5	+42	-18	-78
4,47	3,46	+13	-47	-107	141	109,4	+43	-17	-77
5,01	3,88	+14	-46	-106	159	122,8	+44	-16	-76
5,62	4,36	+15	-45	-105	178	137,7	+45	-15	-75
6,31	4,89	+16	-44	-104	200	154,5	+46	-14	-74
7,08	5,48	+17	-43	-103	224	173,4	+47	-13	-73
7,94	6,15	+18	-42	-102	251	194,6	+48	-12	-72
8,91	6,90	+19	-41	-101	282	218,3	+49	-11	-71
10,0	7,75	+20	-40	-100	316	244,9	+50	-10	-70
11,2	8,69	+21	-39	-99	355	274,8	+51	-9	-69
12,6	9,75	+22	-38	-98	398	308,4	+52	-8	-68
14,1	10,9	+23	-37	-97	447	346,0	+53	-7	-67
15,8	12,3	+24	-36	-96	501	388,2	+54	-6	-66
17,8	13,8	+25	-35	-95	562	435,6	+55	-5	-65
20,0	15,5	+26	-34	-94	631	488,7	+56	-4	-64
22,4	17,3	+27	-33	-93	708	548,4	+57	-3	-63
25,1	19,5	+28	-32	-92	794	615,3	+58	-2	-62
28,2	21,8	+29	-31	-91	891	690,4	+59	-1	-61
31,6	24,5	+30	-30	-90	1000	774,6	+60	±0	-60

The column with the bold figures contains voltage values. The next three columns give the corresponding decibel values when interpreting the voltages as Volt, millivolt, or microvolt. The first column specifies the voltage ratios that correspond to the dBu values relative to Volt.

This table is based on the definition $0 \text{ dBu} \equiv 0.775V_{\text{eff}}$.

1,3 Requirement for calibration

Each mixing console that leaves the factory is shipped with a test report that contains the data of the final inspection such as:

- Alignment to the nominal level specified by the customer
- Frequency response, distortion, signal-to-noise ratio, noise voltage and channel separation.

Recalibration of the mixing console is required when the operating parameters (nominal level) change or after modifications to the mixing consoles have been made. The only scheduled maintenance required is the demagnetization of the input transformers (see 1.8).

Note: Factory supplied (exchange) modules are prealigned to a nominal level of +6 dBu and can be installed directly into the mixing console.

1.4 Required tools and utensils

- Audio frequency generator 1 kHz sin./Rs $\leq 200\Omega$
- AF voltmeter, Rz in $\geq 10\text{ k}\Omega$
- 2-channel CRO
- Alignment screwdriver, size 2
- Bus adapter for connecting unplugged modules to the bus. At least the following are required:

1 Adapter with 32-pin connector	Part No. 1.228.322.81
2 Adapter with 64-pin connector	Part No. (1 pce.) 1.228.327.81
- 2 Extractors for the modules Part No. (1 pcs) **1.912.000.06**
- Firm, non-conductive support (rubber or cardboard), as a base for the modules that have been removed and connected to the bus via the adapter. (these should preferably be placed on the control panel of the audio console)
Size approx. 400 x 250 mm

1.5 Electrostatically Sensitive Elements "ESE"



Static electricity

In our daily activities numerous materials may be a possible source of static electricity. If certain circumstances are given, a person and the various things that are being handled may build up considerable static charges. When it comes to a discharge of such a static potential, very high peak power pulses may result. Even a small portion of such energy, when finding its way into an electronic component, will result in damage or even destruction of that component.

Handling of ESE-assemblies

It must be our aim, therefore, to protect our products from damages and fault conditions that may be the result of electrostatic discharges. Correct handling of electronic assemblies when performing service work on equipment is of utmost importance. For this the following safe handling procedures have to be observed:

ALIGNMENT

1. Discharge your body by touching earth before picking up an electronic assembly.
2. Touch your partner first (handshake) before handing an assembly to him.
3. When handling complete PC-boards, make it your standard practice to hold them only at their edge or at their front panel.
4. Never touch the conductive tracks, terminal points or components on a circuit board without having first discharged yourself.
5. Switch off the electric current supply to the equipment before removing or inserting an ESE assembly.
6. Always use ESE packaging for transportation or storage of ESE assemblies.
7. Make sure to use only tools that are approved for ESE work.
8. An earthed wrist-band is to be carried whenever performing any work on or with electronic assemblies, irrespective of whether they contain ESE or not.
9. Keep Styropor, PVC folis, plastic bags, etc. far away from ESE assemblies.

- **ESE-kit** This kit consists of an earthed protective base (60 × 70cm) with earthed wrist-band for any work with electronic assemblies. Part No.
20.020.001.44

1.6 Calibration requirements

Temperature: The mixing console should be calibrated when it has attained the normal operating temperature (approx. 15 minutes after power on)

Load:

- The insert points (INSERTs), monitor, prefader listening (PFL) and talk-back (TB) outputs should not be loaded ($R_L \geq 10 \text{ k}\Omega$)
- The line outputs (Group, master, aux master) should be terminated with a 600Ω load.

Test signal: Sine-wave signal / 1 kHz

Level reference: **All specifications in this calibration instruction relate to a nominal level of +6dBu.**
If other nominal levels are used, the values according to the following table are applicable:

Overview:

Nominal level	Insert balanced	Insert unbalanced	Line outputs	OVU Indication (6dB lead)	0dB Indication (PPM)
+6dBu	+6dBu	0dBu	+6dBu	0dBu	+6dBu
+10dBu	+10dBu	+4dBu	+10dBu	+4dBu	+10dBu
+15dBu	+15dBu	+9dBu	+15dBu	+9dBu	+15dBu

Insert level: Balanced insert points are at nominal level whereas unbalanced versions carry a level that is 6 dB lower.

1.7 Measuring setup

Removing and monting the assemblies:

Remove the unit to be calibrated and connect it to the audio console with the bus adapter cable.

The zero-ohm-bus amplifiers are sensitive to the peak voltages that may occur when plugging in assemblies to the powered console. For this reason the following units must never be removed or plugged in unless the audio console is switched off:

- VCA fader; master fader; group fader; AUX master; studio monitor; CR monitor.

Balanced Instruments:

AF voltmeter and AF generator must be equipped with balanced inputs and outputs.

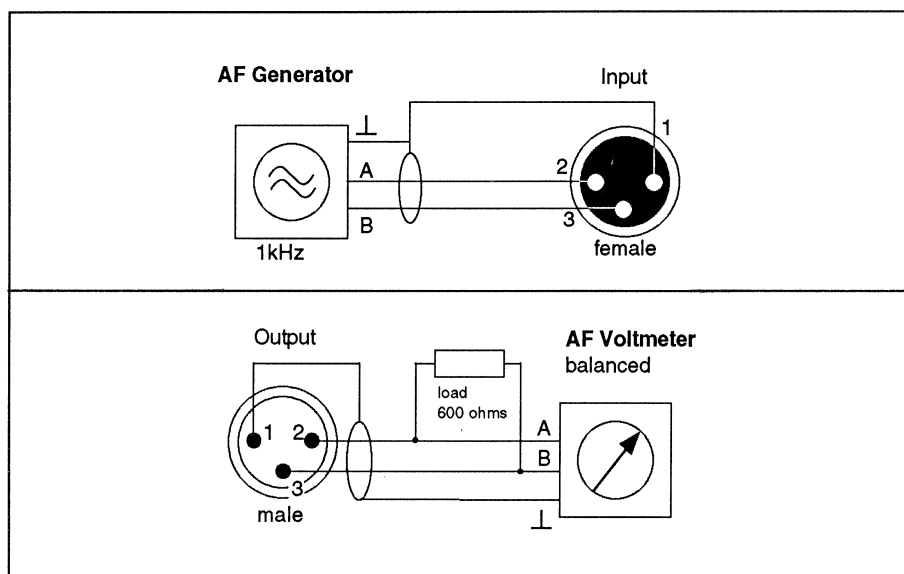

Fig. 1 Connection of the AF generator with balanced line. The measurements with the audio voltmeter are performed with or without loading the output, depending on the test point

Unbalanced Instruments:

Unbalanced instruments are to be connected via a line balance transformer. If this is not feasible, the following wiring can be used as an expedient:

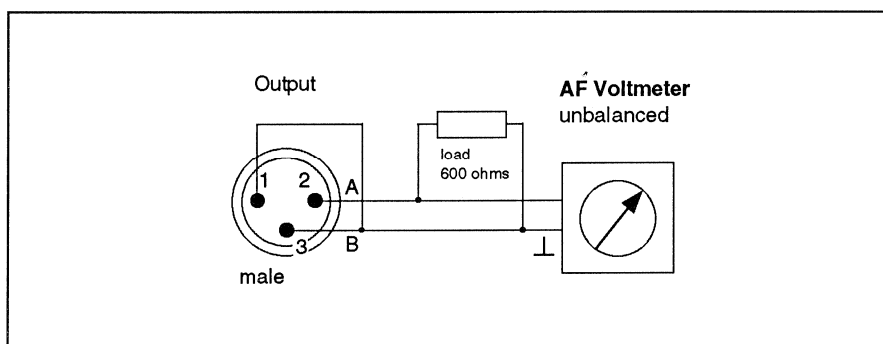

Fig. 2

The b-line (3) connected to the audio ground (1) together with the a-line (2) constitutes an unbalanced test point. However, this circuit arrangement cannot be used for high output levels (clipping effect on electronically balanced outputs, e.g. INSERT).

ALIGNMENT

Measurements on insert points:

The switch contacts of the jack sockets interrupt the signal flow through the channel as soon as a jack is inserted. However, when measurements are taken on INSERT points, the signal path should not be interrupted. For this reason the following should be noted:

- Unbalanced inserts must be through-connected (SEND → RETURN).
- Balanced inserts can be measured on the insert SEND socket. The signal is only interrupted when the RETURN socket is used.

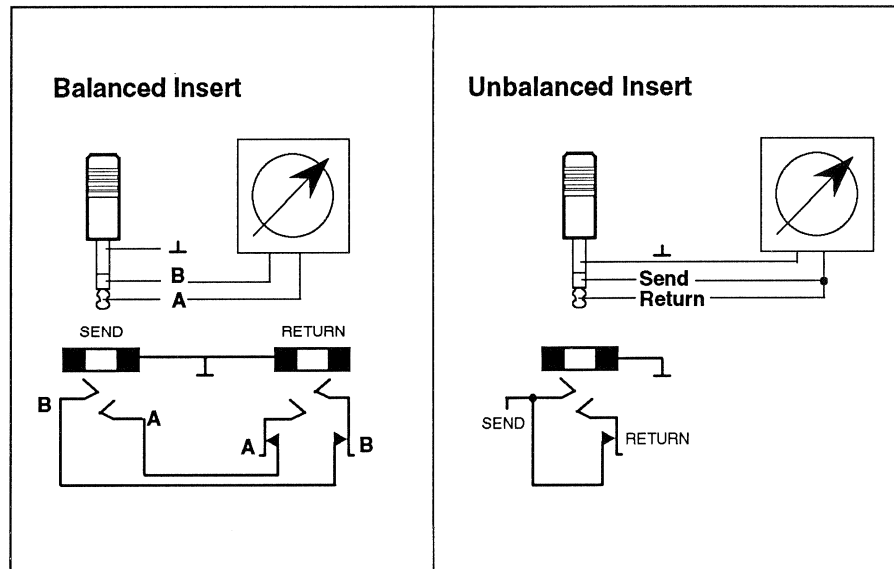

Fig. 3 Measurement on balanced and unbalanced inserts. The signal flow should not be interrupted.

1.8 Demagnetizing the Microphone Input Transformers

Inadmissible connection of unbalanced input sources or unintentional ground connection of the a/b audio (leads of microphone inputs to a connected phantom supply) drive the input transformers into saturation and cause permanent magnetization (remanence).

This detrimental effect is manifested through so-called microphonic noise: (light metallic vibrations of the mixing console, e.g. tapping against plug-in modules, produce audible modulations via the speakers, even if the microphone inputs are not connected).

The residual magnetism in the transformers can also accumulate over extended operating times.

We therefore recommend to demagnetize all microphone inputs periodically and before calibration work:

- Procedure:**
- Switch audio console off (to protect the connected speakers).
 - Connect audio generator to the microphone input.
The generator should supply a signal without DC content in order to prevent unwanted magnetization of the transformer.

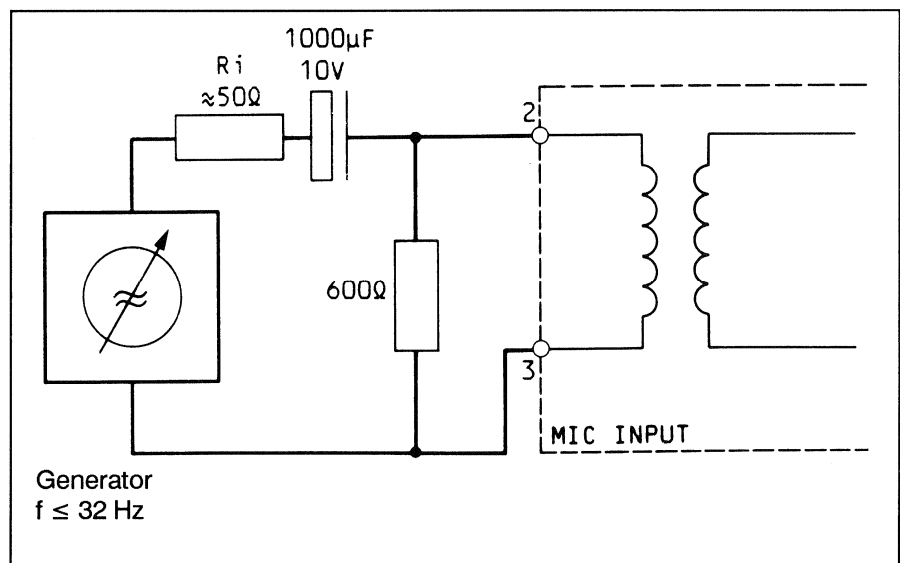

Fig. 4 Connection of the AF-generator to microphone inputs.

- Capacitor $C=1000\mu\text{F}/10\text{V}$ blocks the DC components.
- Resistor $R600\Omega$ removes DC components from the capacitors.
- Slowly increase generator level (frequency $\leq 32\text{Hz}$) from 0V to 3V.
- **Slowly** decrease supply level to 0V.

ALIGNMENT

2. Units of the fader panel

Remove the unit for calibration and connect it to the audio console with the bus adapter cable.

All filters, EQ, balance and panorama potentiometers have to be switched off during calibration.

2.1 Mono/stereo fader unit

1.911.110/112/120/122

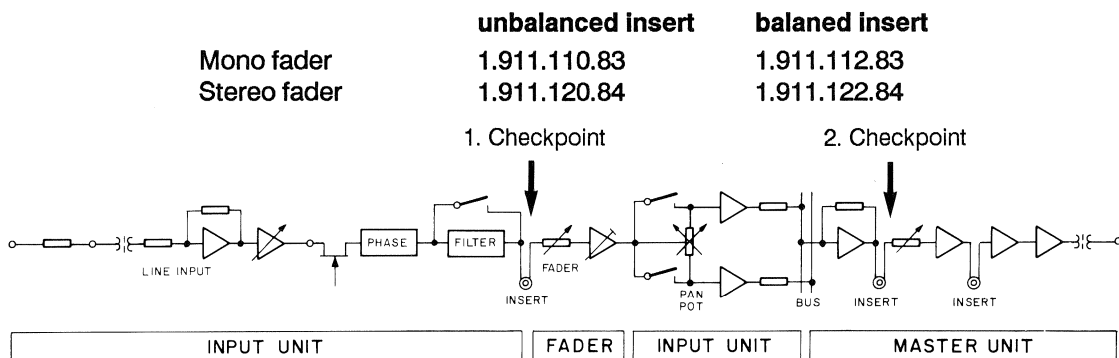

- Feed test signal at nominal level to the input unit.
- Connect the AC voltmeter to the PF insert. (test point 1)
- Set the potentiometer LINE GAIN of the input unit to middle position and switch off the equalizer. If you cannot measure a PF insert level as listed below, the input unit has to be calibrated.
 - a) Unbalanced insert: **0dBu**
 - b) Balanced insert: **+6dBu**
- Position the fader at **0dB**.
- Select a master on the input unit, switch off the panorama potentiometer and connect the DC voltmeter to the PF insert of this master. (corresponds to the output level of the input fader; test point 2)
- Align the level with the trimmers **R23** of the mono fader or **R109** -left- and **R209** -right- of the stereo fader:
 - a) For unbalanced master inserts: **0dBu**
 - b) For balanced master inserts: **+6dBu**

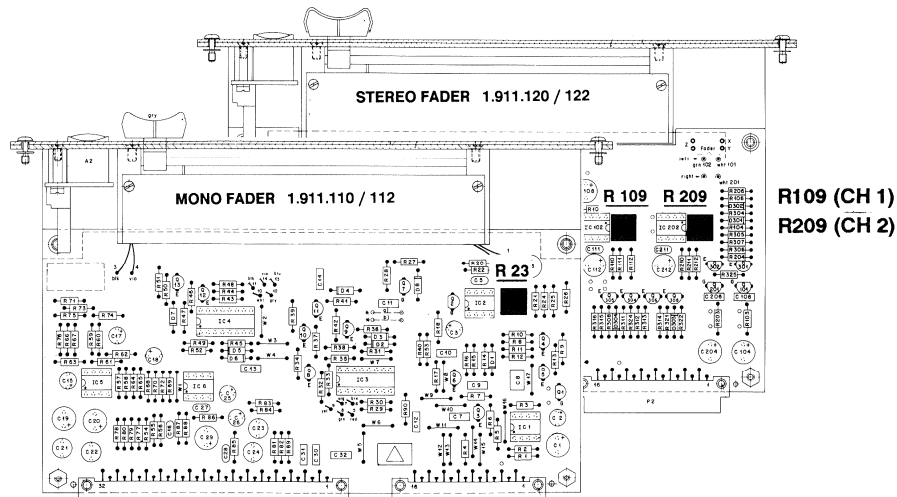

Fig. 5 Alignment elements of mono and stereo fader units.

2.2 Master fader Mk II

1.911.315/325/335

	without limiter	with limiter
Mono master unit Mk II	1.911.315	1.911.317
Stereo master unit Mk II	1.911.325	1.911.335

The corresponding circuit boards are numbered as 1.911.323 (mono) and 1.911.323/324 (stereo).

AF insert level:

- Feed test signal at nominal level to a calibrated input and rout it to the master.
- Connect the voltmeter to the AF INSERT OUT of this master fader.
- Set the input fader and the master fader to 0dB.
- Calibrate the AF INSERT OUT with R142 for CH1 (or R342 for CH2) to the corresponding insert level. (see 1.6)

Master output level:

- Feed same test signal as described above and set the input fader and the master fader to 0dB.
- Connect the AF voltmeter to the master output and adjust it to nominal level with R152 for CH 1 or R352 for CH 2.
- Subsequently select next master on the input unit and repeat foregoing procedure with that unit. Align all master faders in the same manner.

Distortion alignment:

No distortion alignment is necessary because the output stage compensates distortion.

Notes:

- The components of the 1st channel (PCB No. 1.911.323) are assigned the position numbers 100 to 299, those of the second channel the numbers 300 to 499 (PCB No. 1.911.324).
- The two channels of the stereo version are identical and completely separated. However, these two boards are mirror symmetrical.

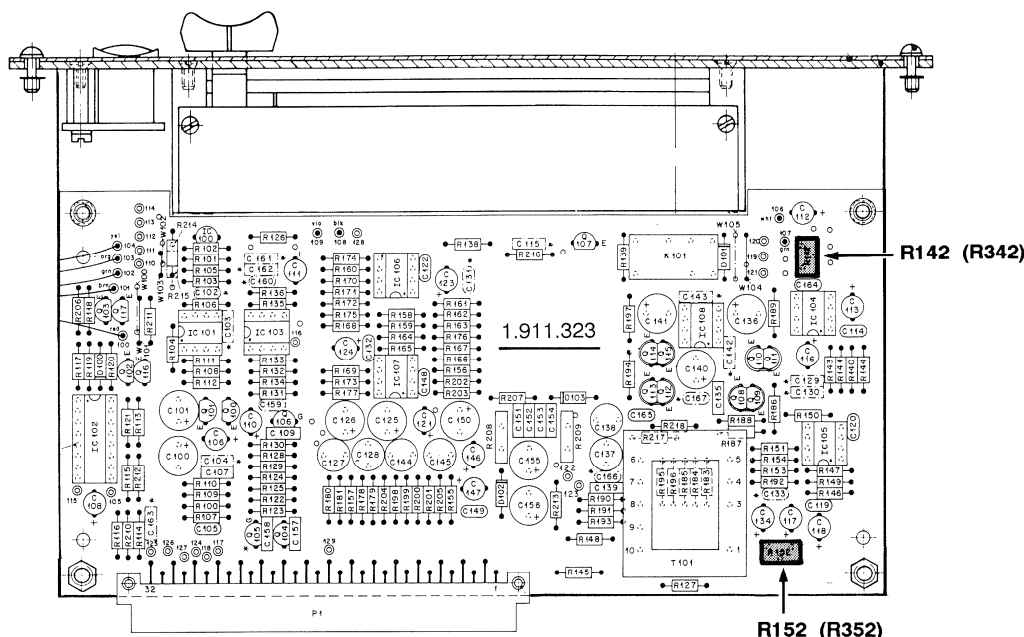

Fig. 6: Alignment elements of the master unit MkII.

Channel 1: (Σ1, 3, 5..) R142: AF insert OUT R152: Master output level
 Channel 2: (Σ2, 4, 6..) R342: AF insert OUT R352: Master output level

ALIGNMENT

3. Units of the input panel

Use the suitable bus adapter cables for connecting P3, P4 and P6 of the removed unit to the audio console. Switch off all non-linear functions as filters, EQ, phase and limiters.

3.1 Input units mono "A"

1.912.220...226

- Connect AF voltmeter to the **PF insert**. (For a correct connection to the insert socket see 1.7 "measuring setup")
- Switch off both filters.
- Switch off the equalizer.

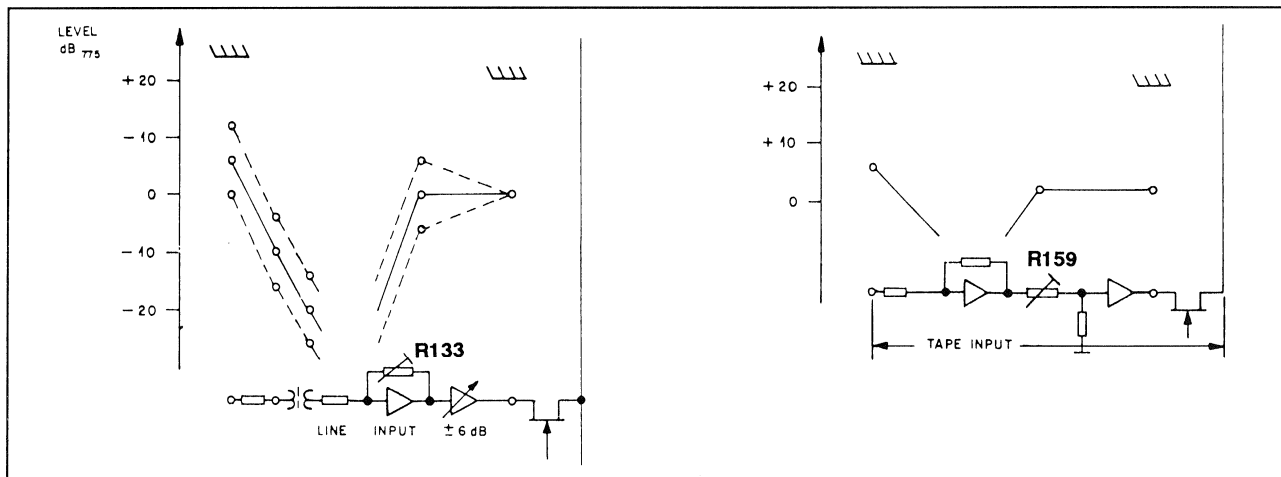

Fig. 7 Block diagram

Line input:

- Feed the test signal at nominal level to the line input.
- Set the correction potentiometer LINE GAIN to the self-locking CAL position.
- Adjust level with **R133** to **0dBu**. (balanced insert levels see 1.6)

Tape input:

- Feed the test signal at nominal level to the tape input.
- Adjust level with **R159** to **0dBu**. (balanced insert levels see 1.6)

Common mode rejection:

- The electronically balanced tape input needs adjustment of the common mode rejection. Feed the test signal to the a- and b-line of the input as depicted in fig.8.

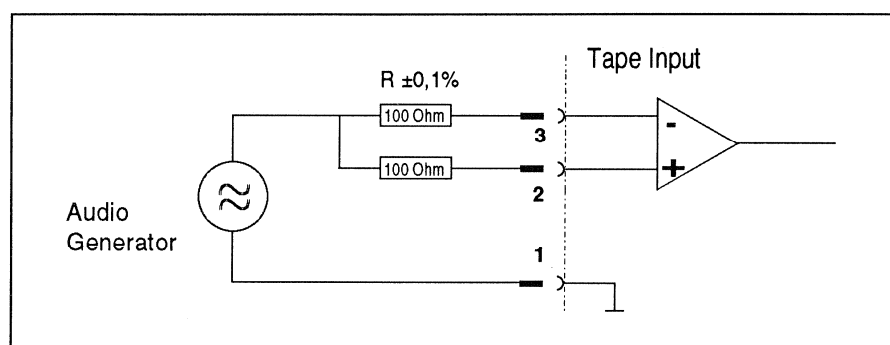

Fig. 8 Feeding the test signal for the adjustment of common mode rejection.

- Minimize the level at the inputs PF insert with R153.
(common mode rejection at 1kHz/+6dBu \geq 80dB i.e. values in the μ V range).

Microphone input: No calibration is needed for the microphone input other than demagnetizing the input transformers. (see 1.6)

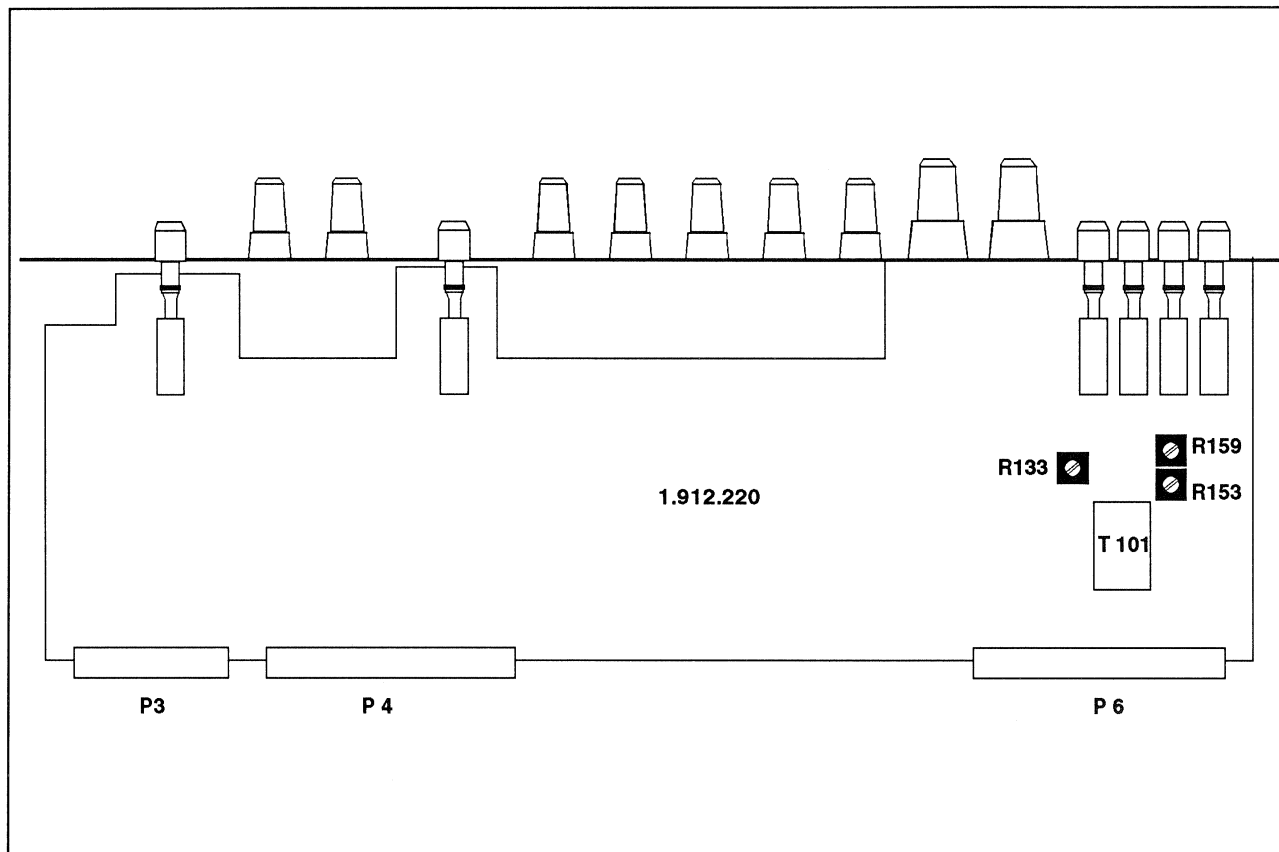

Fig. 9 Alignment elements of the input unit version 'A'

ALIGNMENT

3.2 Input units stereo high level "A"

1.912.240...243

Both line inputs 1 and 2 share the same input stage. The calibration of one input is sufficient.

- Set the GAIN potentiometer to the self-locking center position.
- Switch off the STEREO SPREAD, EQUALIZER and the MONO key.
- Press the input selector key LINE 1.

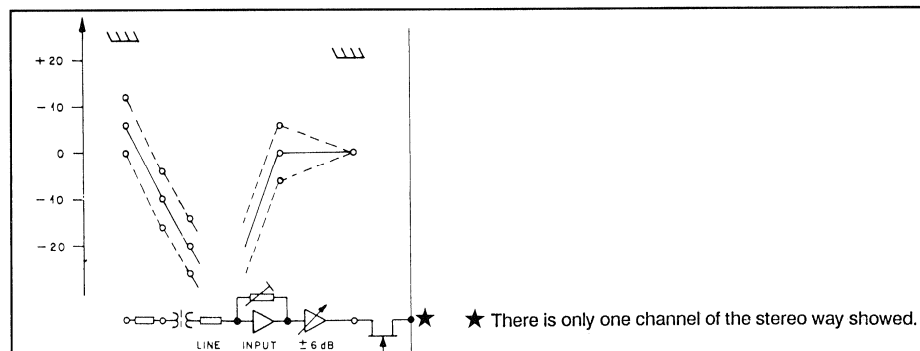

Fig. 10 Block diagram

Line input left:

- Feed test signal at nominal level to the input LINE 1, left.
- Connect voltmeter to the **PF insert left** (patch or P3-15).
- Adjust the left channel with **R114** to **0dBu**. (balanced insert levels see 1.6)

Line input right:

- Feed test signal at nominal level to the input LINE 1, right.
- Connect voltmeter to the **PF insert right** (patch or P3-13).
- Adjust the right channel with **R214** to **0dBu**. (balanced insert levels see 1.6)

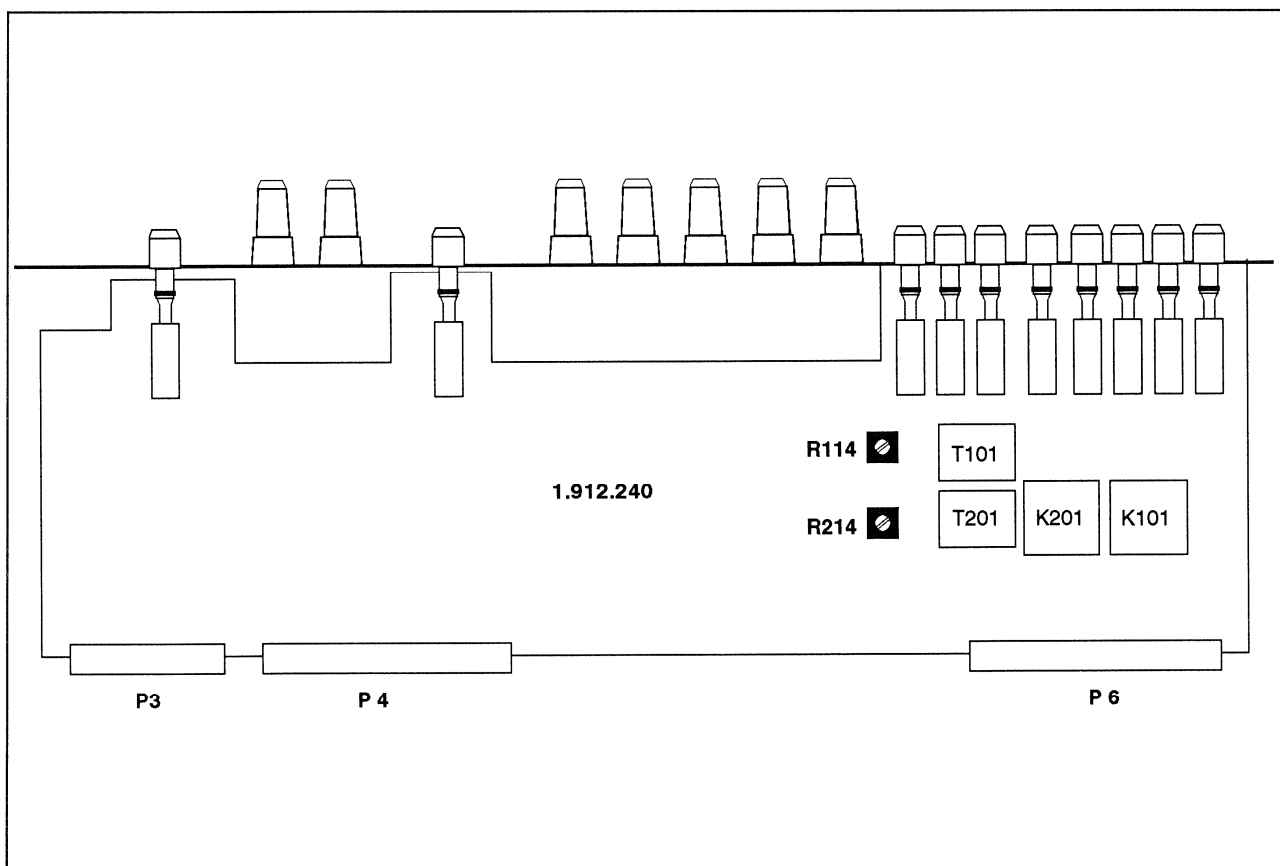

Fig. 11 Alignment elements of the input unit stereo high level version "A".

3.3 Input units stereo universal "A"

1.912.250...253

- Switch off FILTER, EQUALIZER and STEREO SPREAD.

Line input:

- Set the LINE GAIN potentiometer to the self-locking center position.
- Select the LINE input.

left channel

- Feed test signal at nominal level to the LINE input, left channel.
- Connect voltmeter to the **PF insert left** (patch or P3-15).
- Adjust the left channel with **R125** to **0dBu**. (balanced insert levels see 1.6)

right channel

- Feed test signal at nominal level to the LINE input, right channel.
- Connect voltmeter to the **PF insert right** (patch or P3-13).
- Adjust the right channel with **R325** to **0dBu**. (balanced insert levels see 1.6)

Microphone input:

No adjustment is needed for the microphone input other than demagnetizing the input transformers. (see 1.8)

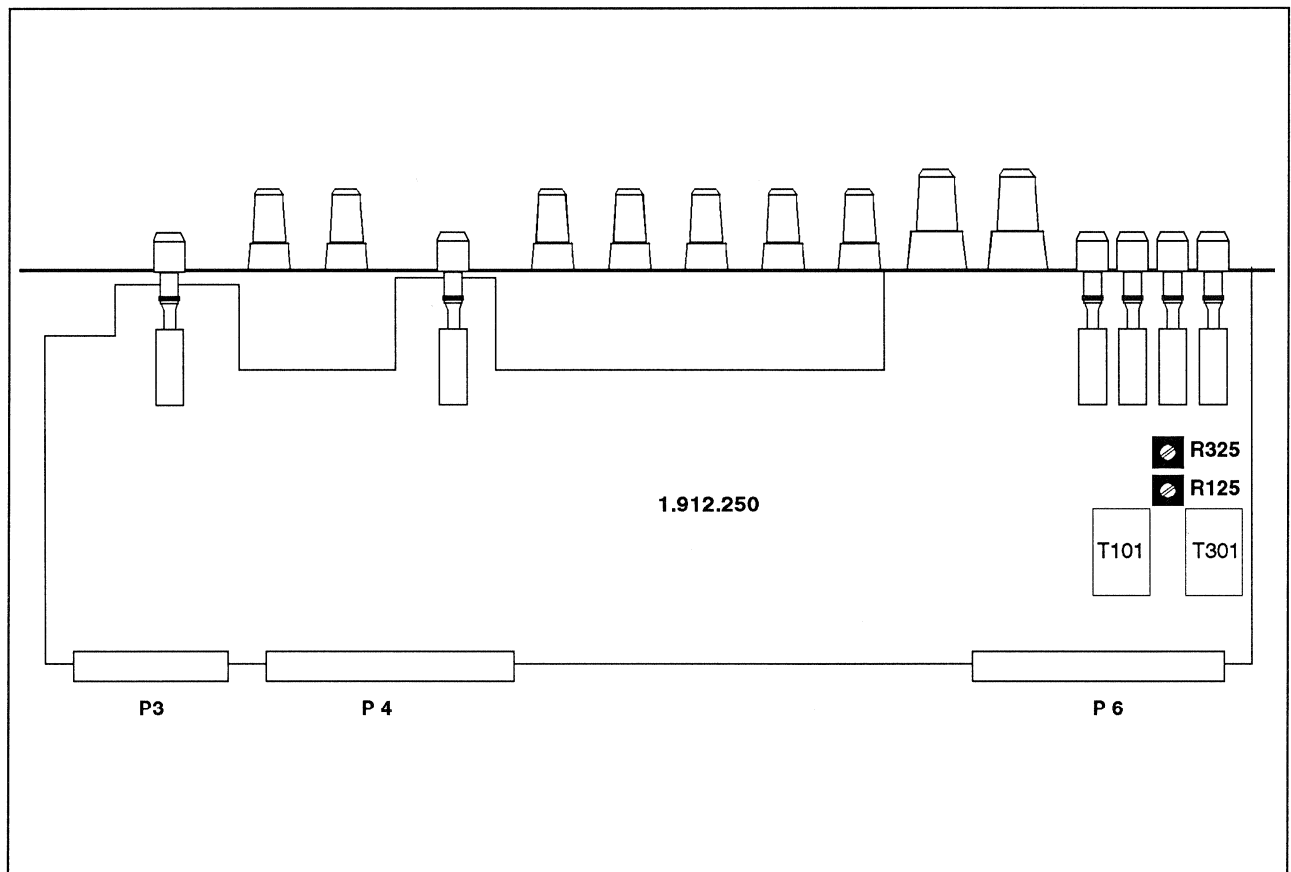

Fig. 12 Trimmer potentiometers for the calibration of the LINE input.

ALIGNMENT

3.4 Input units mono "B"

1.912.120/122

- Switch off EQUALIZER and FILTER.

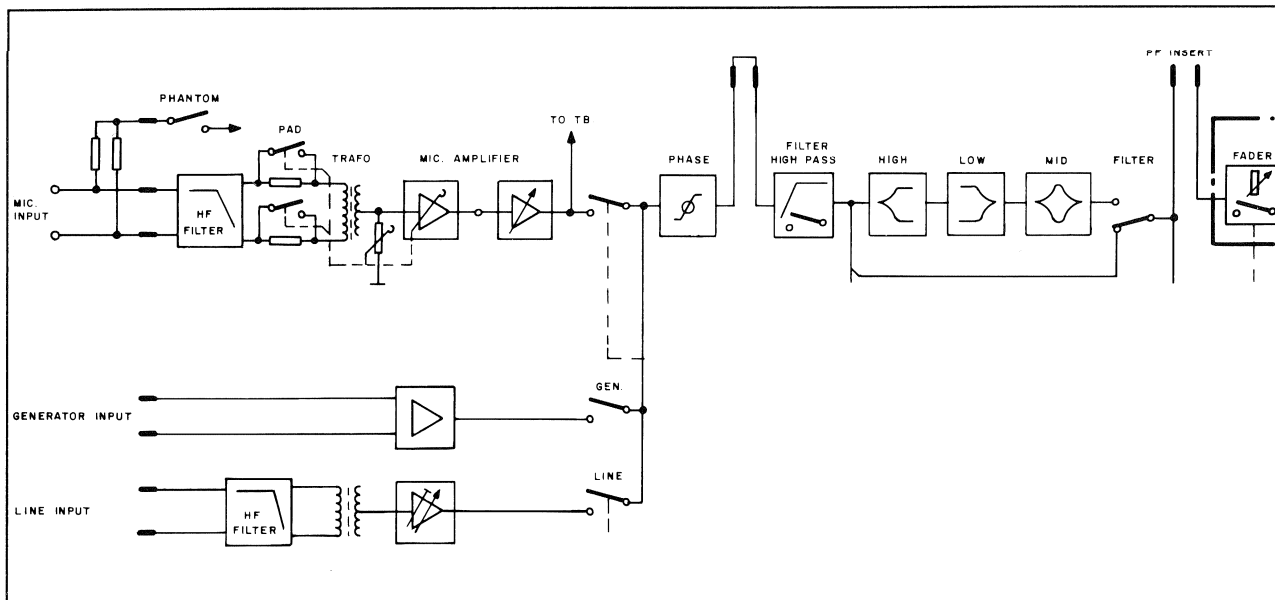

Fig. 13 Block diagram

Line input:

- Feed test signal at nominal level to the LINE input.
- Set the potentiometer LINE GAIN to the self-locking CAL position.
- Connect voltmeter to the PF insert (patch or P6-27).
- Adjust the level with R35 to 0dBu. (balanced insert levels see 1.6)

Other inputs:

The input stages for microphone and audio generator don't need calibration.

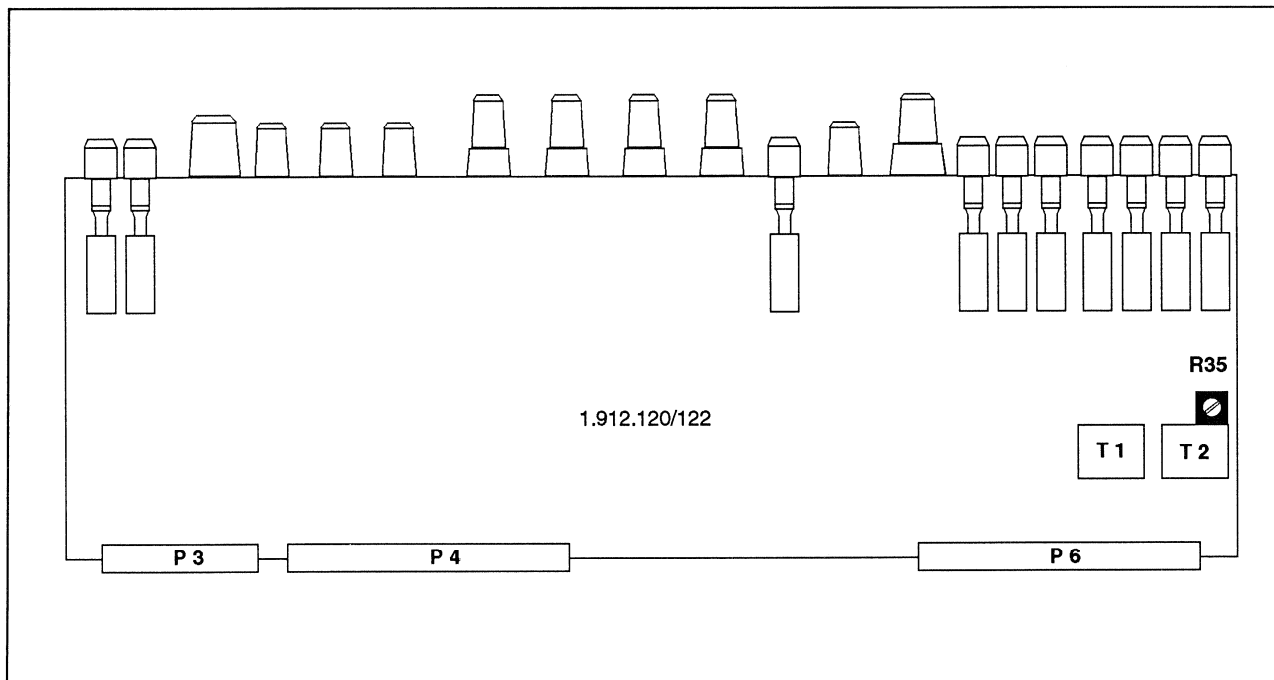

Fig. 14 Alignment elements for the mono input units version "B".

3.5 Input units stereo high level "B"

1.912.141...145

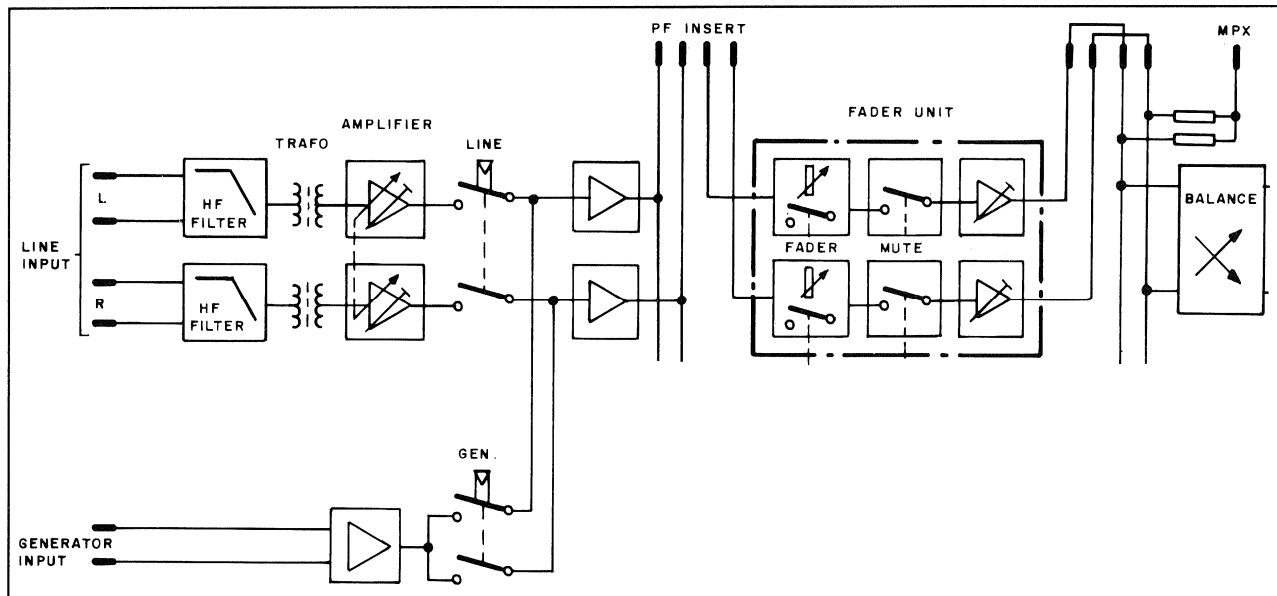

Fig. 15 Block diagram

Line input:

- Set the LINE GAIN potentiometer to the self-locking center position.

left channel

- Feed test signal at nominal level to the LINE input left channel.
- Connect voltmeter to the PF insert left (patch or P3-15).
- Adjust the left channel with R109 to 0dBu. (balanced insert levels see 1.6)

right channel

- Feed test signal at nominal level to the LINE input right channel.
- Connect voltmeter to the PF insert right (patch or P3-13).
- Adjust the right channel with R209 to 0dBu. (balanced insert levels see 1.6)

Generator:

The input stage for the audio generator doesn't need any calibration.

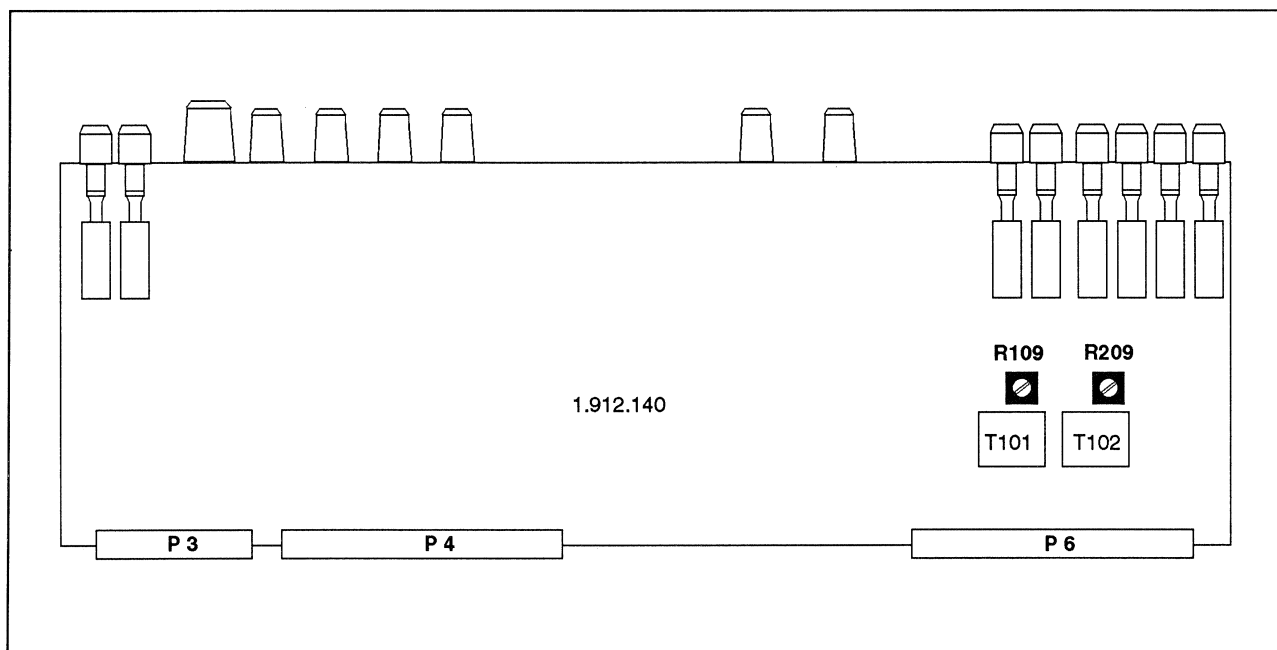

Fig. 16 Alignment elements of the stereo input units version "B".

ALIGNMENT

3.6 Auxiliary master unit

1.912.310

AUX output level:

The output levels of the AUX masters at maximum gain in the AUX path are aligned to **10dB above nominal level**.

- Feed test signal at **nominal level** to LINE input 1 and set the input fader to 0dB.
- Completely open the **AUX** potentiometers 1...4 of the input in the PF position by turning it fully clockwise. ☉
- Completely open also the potentiometers **AUX SEND 1...4** of the AUX master unit by turning them fully clockwise. ☉

AUX 1...3

- Connect the voltmeter to the corresponding **AUX output**.
- With a jumper (0dB/-10dB) and a trimmer align the level to 10dB above the nominal level. The alignment controls for the corresponding AUX path are shown in the table below.

AUX 4

- Perform the alignment as described above.
- Turn the AUX balance potentiometer (input unit) to the extreme **left** position ☉ and adjust the output AUX 4L with **R425** to 10dB above nominal level.
- Turn the AUX balance potentiometer (input unit) to the extreme **right** position ☉ and adjust the output AUX 4R with **R525** to 10dB above nominal level.

Distortion alignment:

This alignment is only necessary after an output stage has been repaired.

- Connect the voltmeter to AUX output.
- Switch the 30Hz sine wave signal from the audio generator to the AUX master to be calibrated.
- Increase the output level to +24dBu and subsequently align to minimal distortion with the aid of the trimmer potentiometers listed below.

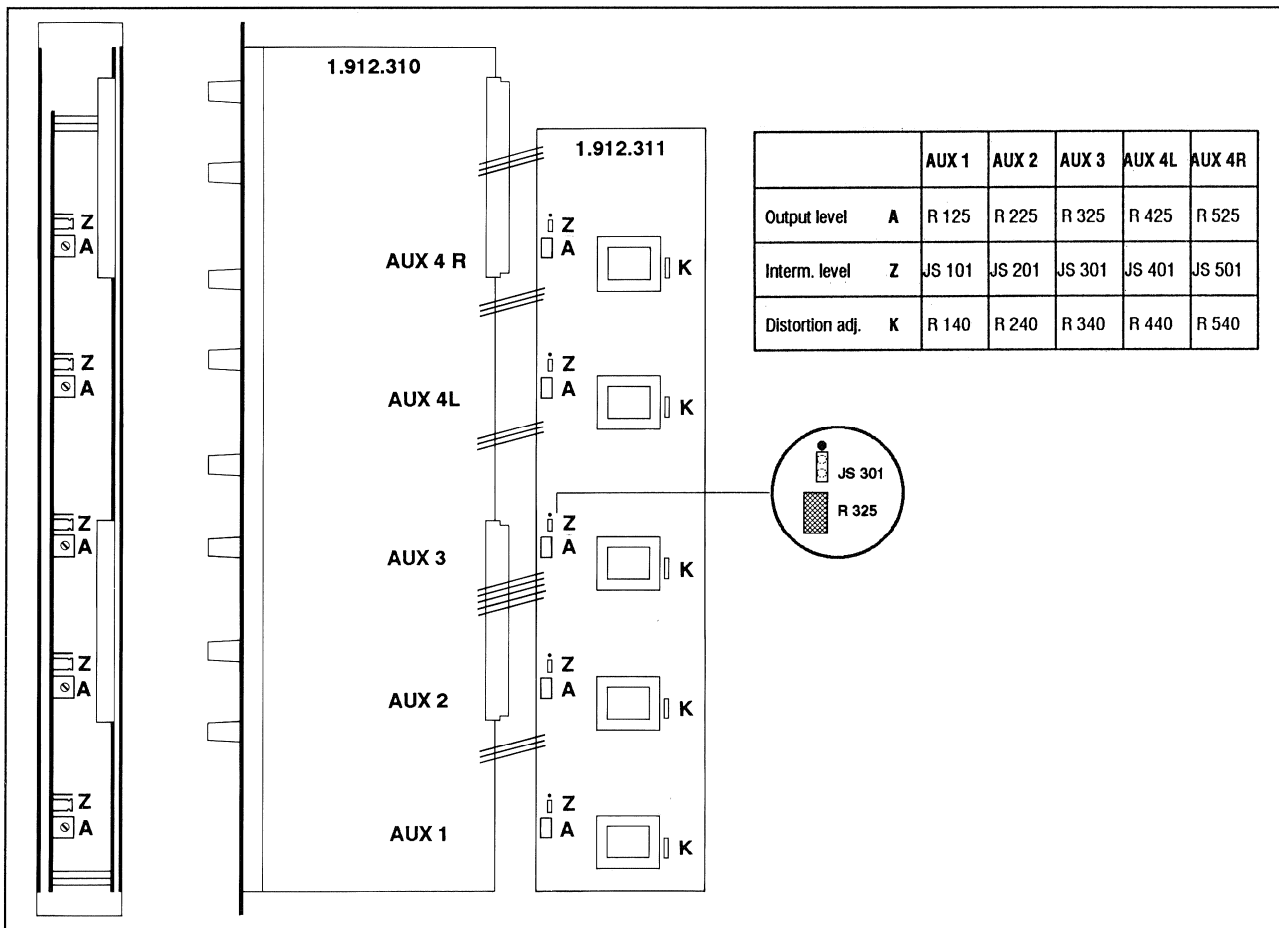

Fig. 17 Location of trimmer potentiometers on the AUX master unit.

3.7 Control Room Monitor

1.912.420

To start the alignment no key on the CR monitor unit must be pressed.

- Feed test signal at **nominal level** to the input EXTERNAL 1 left or right.
- Select the input EXT 1 on the CR monitor.
- Completely open the potentiometer MONITOR VOLUME by turning it clockwise. ☺
- Make sure that the BALANCE is switched off (BALANCE IN key).

Headphones level:

- Connect voltmeter with no load to one of the 6.3mm headphone sockets: tip = left channel / ring = right channel / sleeve = 0V
- Adjust level with **R7** left and **R64** right to **+20dBu** (7,75V).

CR monitor:

- Connect voltmeter with no load to the CR MONITOR output left or right
- Adjust the output level with **R30** left and **R82** right to **+16dBu**.

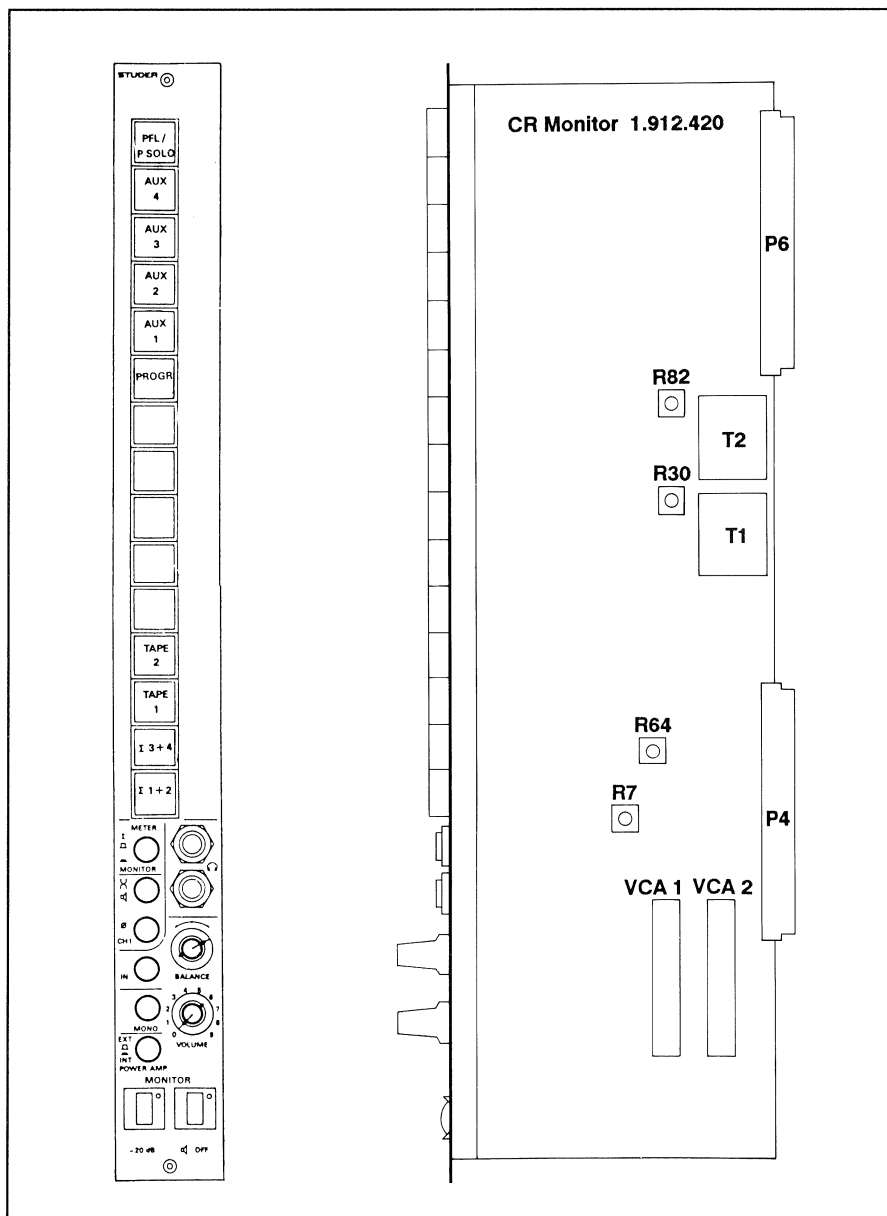

Fig. 18 Alignment elements of the CR Monitor unit. 1.912.420.

ALIGNMENT

3.8 Studio Monitor and Talk Back unit

1.912.320

The control room monitor unit must be calibrated before the alignment of the studio monitor.

- PFL level:**
- Feed test signal at **nominal level** to the LINE input (gain: CAL) of the input unit.
 - Press **PFL** key on this input unit.
 - Completely open the potentiometer MONITOR VOLUME of the CR Monitor unit by turning it completely clockwise. ☉
 - Press PFL/P.SOLO to MONITOR key on the Studio Monitor unit. The potentiometer PFL/P.SOLO has no influence on the signal level of the CR MONITOR output.

- PFL/P.SOLO monitor:**
- Connect the voltmeter with no load to the CR MONITOR output.
 - Adjust with **R67** left and with **R70** right to **+16dBu**.

- PFL/P.SOLO headphones:**
- Completely open the PFL/P.SOLO potentiometer ☉.
 - Connect voltmeter with no load to the headphones socket PFL/P.SOLO. tip = left channel / ring = right channel / sleeve = 0V
 - Adjust with **R79** left and with **R87** right to **+20dBu**.

- Notes:**
- The Studio Monitor is muted as soon as a microphone is on. In this case the CUT LED is light. Muting can be released with the RE-IN key.
 - The TB STUDIO and TB SPEAKER keys attenuate the studio output level for 20dB and must therefore not be activated.

- Studio Monitor:**
- Feed test signal at **nominal level** to one of the monitor inputs EXTERNAL and press the corresponding source selector key.
 - Completely open the STUDIO potentiometer. ☉
 - Connect voltmeter with no load to the STUDIO output left or right.
 - Adjust with **R11** left and with **R32** right to **+16dBu**.

- Headphones studio:**
- This adjustment affects the level of the studio monitor signal going out to the studio headphones. (e.g. connected to TB box)
 - Feed test signal as described for the studio monitor alignment.
 - Connect voltmeter with no load to the output TB box (D-type) or to the headphones socket on the TB box (open VOLUME completely). tip = left channel / ring = right channel / sleeve = 0V
 - Adjust with **R7** left and **R28** right to **+20dBu**.

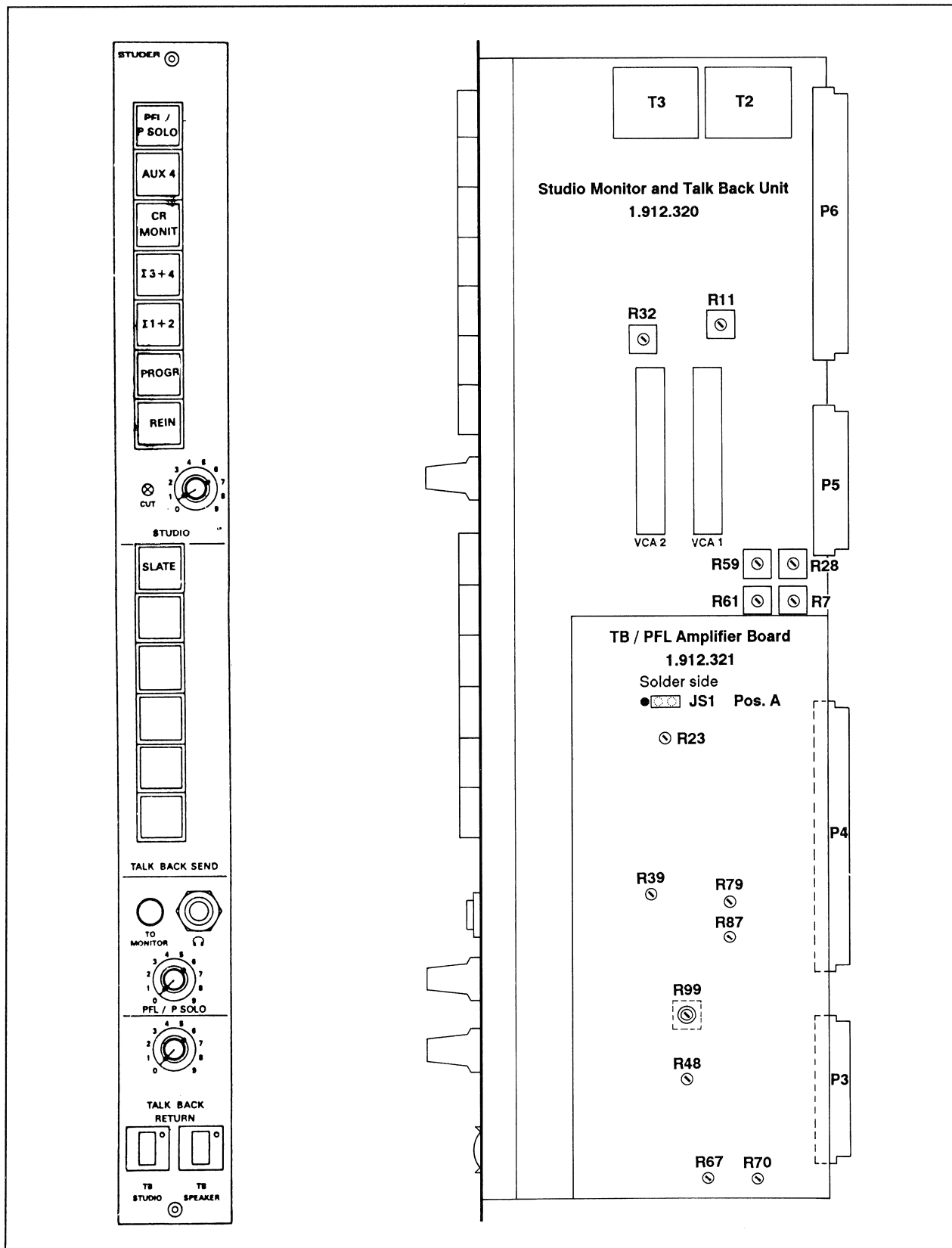

Fig. 19 Alignment elements of the Studio Monitor and Talk Back unit 1.912.320.

ALIGNMENT

Talk Back level:

The level of the TB microphone is adjustable with three different trimmer potentiometers: input gain, level for feeding to studio monitor and to studio headphones separately.

- Feed test signal at **-60dBu** to the microphone socket on the audio console (goose neck). Balanced connection to pin 1 and 3 of the DIN-connector.

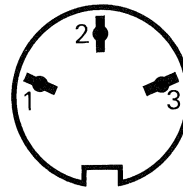

TB microphone
(control room)

- Press the TB SEND A key.
- Connect voltmeter with no load to the output TB EXTERNAL 1.
- Adjust the limiter threshold level for the TB signal with **R99** to **+6dBu**. This trimmer potentiometer is accessible through a hole in the PCB 1.912.321. (The jumper JS1 (on 1.912.321) should be set to position A.)

TB to Studio Monitor

- Press the TB STUDIO key.
- Connect voltmeter with no load to the left channel of the STUDIO output.
- Adjust with **R59** to **+6dBu**.* (R59 affects both channels)
* = factory setting. The level depends on the desired talk back volume.

TB to Studio headphones

- Connect voltmeter with no load to TB box output (D-type) or to the headphones socket of the TB box (open VOLUME completely).
tip = left channel / ring = right channel / sleeve = 0V
- Adjust with **R61** to **+6dBu*** (R61 affects both channels.)
* = factory setting. The level depends on the desired talk back volume.

TB return

- Feed test signal with **+6dBu** to the TB RETURN input.
- In normal operation the TB signalization switches the signal to the PFL/TB speaker. For this reason an external TB key has to be pressed.
(The internal signal 'E' opens the TB RET signal path. Circuit diagram 1.912.320; page 2)
- Completely open the TB RETURN potentiometer \odot .
- Adjust TB RETURN INPUT with **R48** to the desired maximum volume.

Attenuation TB return

To avoid feedback in the control room the TB return signal is attenuated as soon as a TB key in the control room is pressed. The attenuation is adjustable with R39.

- Feed test signal at **-60dBu** to the speaker microphone socket. (D-type)
- Press any TB key on the audio console. This activates the attenuation of the TB return signal. Adjust it with **R39** to the desired value.
factory setting: **-20dB**.
(The internal signal 'D' attenuates the TB RET signal. Circuit diagram 1.912.320; page 2)

Speaker TB microphone

- Use same measuring setup as described above.
- Activate the signalization as described for the TB return signal.
- Completely open the TB RETURN potentiometer \odot .
- Adjust the SPEAKER MIC level with **R23** to the desired maximum volume.

4. Main Instruments

4.1 VU-Meter 1.913.230/231

- Adjust the output level to 6 dB below line level on the master output.
- Adjust with R4 (Fig. 21) to a VU-meter reading of 0 VU.
- This gives the necessary lead of 6 dB.

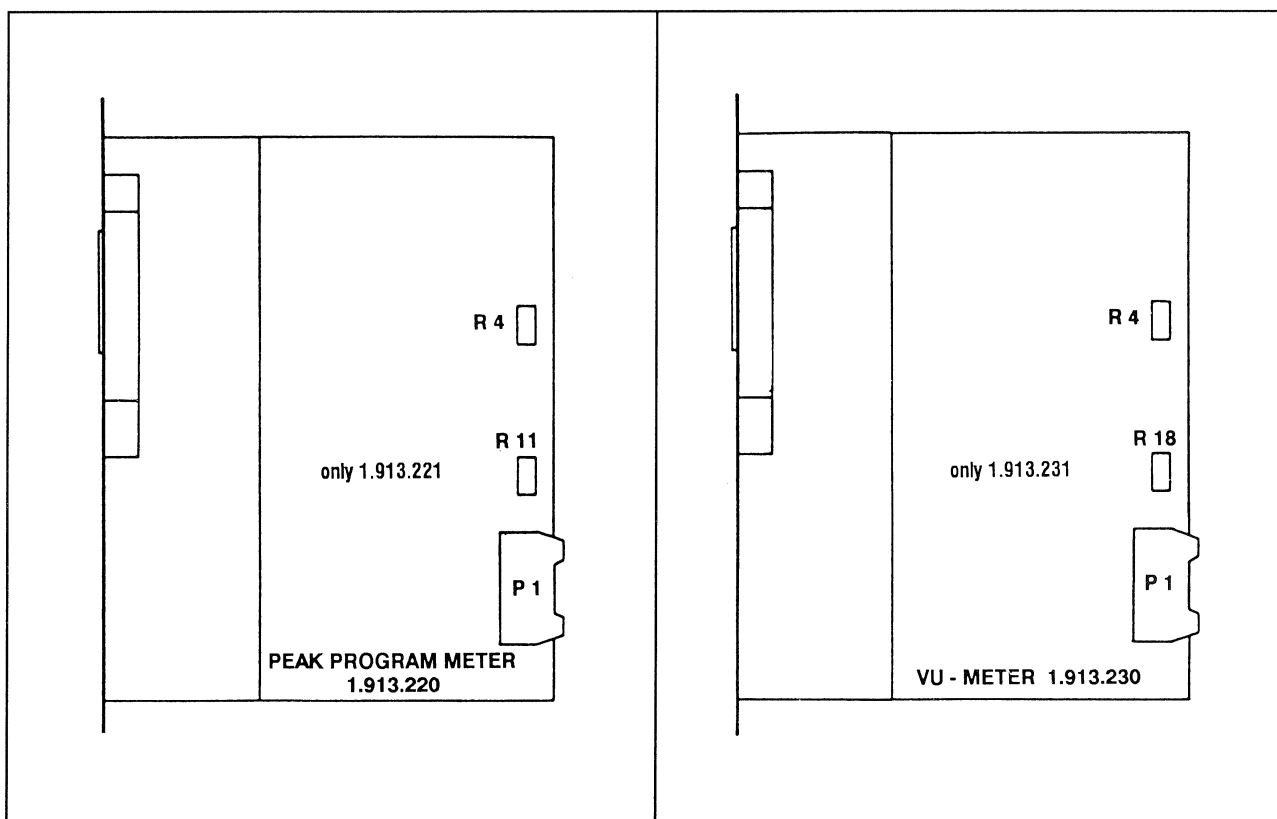

Fig. 20

Fig. 21

4.2 Peak Program Meter (PPM) 1.913.220/221

- Adjust master output to line level.
- Adjust with R4 (Fig. 20) to a needle indication of 0 dB.

ALIGNMENT

4.3 Correlator 1.913.210/211

- Adjust line level at master output 1 and 2.
- Adjust with R4 (Fig. 22) and R13 to -18 dBu or 100 mVAC measured at testpoint 1 (TP1) and testpoint 2 (TP2).
- Output signal in phase at master 1 and 2 (correlate).
- Adjust with R26 to a meter indication of $+1$.

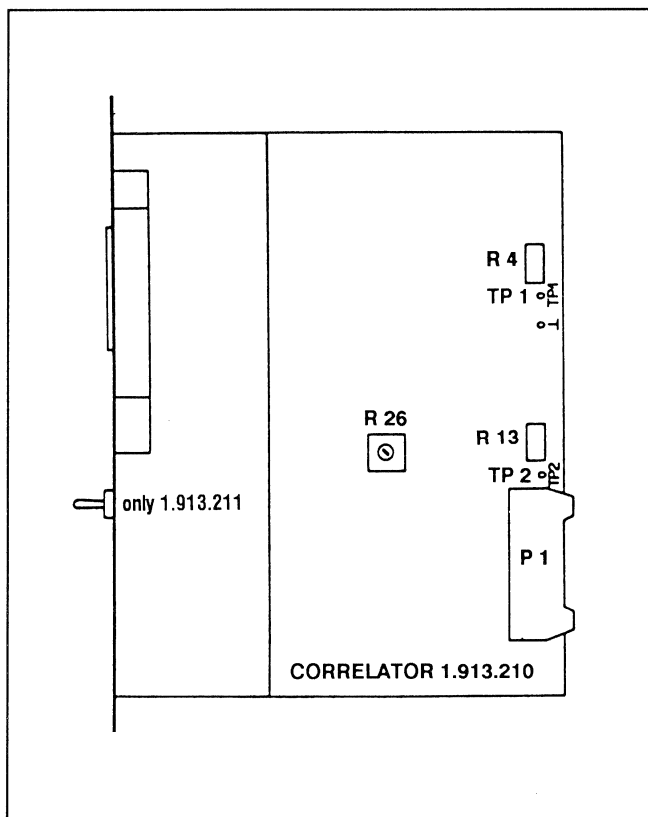

Fig. 22

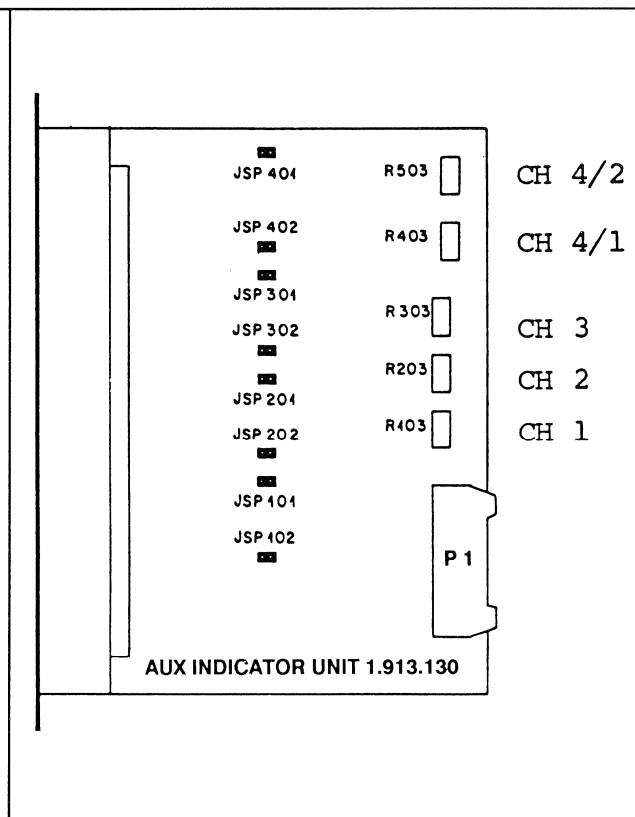

Fig. 23

4.4 AUX Indicator

1.913.130

This unit contains the four instruments of auxiliary outputs. The indication characteristic may be adapted to the main instruments. It is possible to choose between PPM or VU with jumpers. The jumper switches are named JSP (Fig.23).

VU display:

For this type of dynamic characteristic the jumpers must be set as follows:

JSP 102 → Instrument AUX 1

JSP 202 → Instrument AUX 2

JSP 302 → Instrument AUX 3

JSP 402 → Instrument AUX 4

VU meter

Adjustment for peak-level +10dBu / +12dBu.

For these two peak levels the nominal level for a reading of 0VU is +4dBu.

The so-called lead is, therefore, 6dB or 8dB respectively.

AUX 1...3 (VU)

Apply the test signal with **+4dBu** to the input of the instrument to be calibrated. Adjust for a reading of **0VU** with trimmer potentiometers **R103**, **R203** or **R303** (see fig. 23).

AUX 4 (VU)

The AUX 4 instrument displays the mono level of the AUX 4 stereo path. Each channel of AUX 4 has to be adjusted to **-3VU** which results in 0VU reading for both channels together.

- Feed **+4dBu** to **AUX 4/1** (left channel), no signal to AUX 4/2.
- Adjust the instrument with trimmer **R403** (see fig. 23) to **-3VU**.
- Feed **+4dBu** to **AUX 4/2** (right channel), no signal to AUX 4/1.
- Adjust the instrument with trimmer **R503** (see fig. 23) to **-3VU**.

PPM display:

The characteristic of a Peak Program Meter can be obtained by the following jumper setting:

JSP 101 → Instrument AUX 1

JSP 201 → Instrument AUX 2

JSP 301 → Instrument AUX 3

JSP 401 → Instrument AUX 4

AUX 1...3 (PPM)

Apply the test signal with **line level** to the input of the instrument to be calibrated. Adjust for a reading of **0dB** with trimmer potentiometers **R103**, **R203** or **R303** (see fig. 23).

AUX 4 (PPM)

The AUX 4 instrument is aligned in a similar way as described for the VU characteristic.

- Feed **line level** to **AUX 4/1** (left channel), no signal to AUX 4/2.
- Adjust the instrument with trimmer **R403** (see fig. 23) to **-3dB**.
- Feed **line level** to **AUX 4/2** (right channel), no signal to AUX 4/1.
- Adjust the instrument with trimmer **R503** (see fig. 23) to **-3dB**.

ALIGNMENT

4.5 Audio Generator

1.913.150

- Oscillator:**
- Press the **OSCILLATOR** key on the audio generator and set the frequency to **1kHz**.
 - Connect the voltmeter to the balanced output of the audio generator: **P1-1 / P1-3**.
 - Adjust to **line level** with the trimmer potentiometer **R49**.

- Harmonic distortions**
- Set the frequency to **30Hz**.
 - Adjust the distortions with **R59** to **-62dB (0,08%)**.

- Identification:**
- Press the **IDENT** key.
 - Adjust to **line level** with **R52**.

- White noise:**
- Press the **WHITE NOISE** key.
 - Adjust to **line level** with **R67**.

- Pink noise:**
- Press the **PINK NOISE** key.
 - Adjust to **line level** with **R73**.

The irregular deflection of the VU meter instrument with noise signals is due to the circuit layout.

- Audio generator input:**
- Select the input **GEN** on channel 1.
 - Connect the voltmeter without load to the **PF insert** of channel 1.
 - Adjust with **R89** to the insert level of your console (see 1.6).

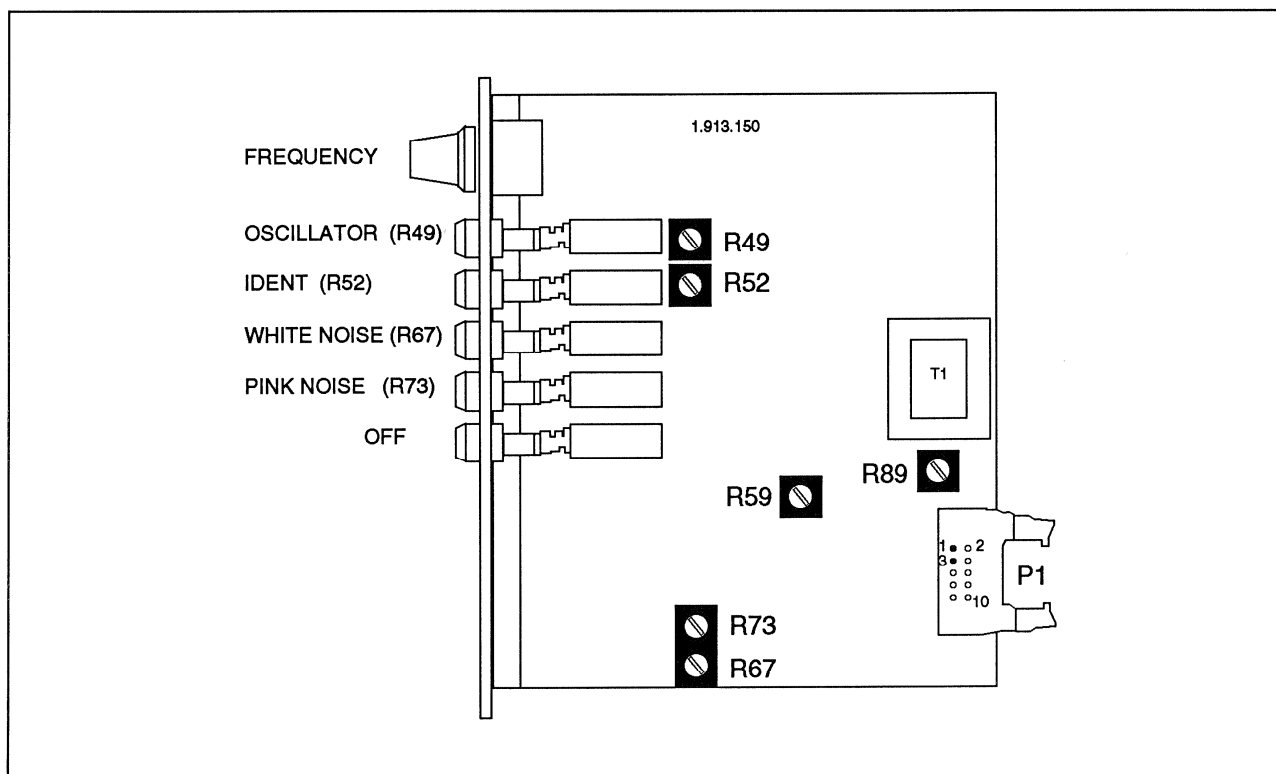

Fig. 24 Trimmer potentiometers for the calibration of the audio generator 1.913.150.

KAPITEL 4: Einschub-Module der Fadersektion 1.911. ...

INHALT

1.	Flachbahnregeler Mono / Stereo	1.911.110...122
2.	Master Unit MkII	1.911.315...335
3.*	VCA-Fader Units	1.911.210 ...216 1.911.220

SECTION 4: Plug-in Units of the fader section 1.911. ...

CONTENTS

1.	Mono / stereo fader	1.911.110...122
2.	Master unit MkII.....	1.911.315...335
3.*	VCA fader units.....	1.911.210 ...216 1.911.220

* Diese Beschreibungen werden kundenspezifisch bestückt.

* These descriptions are supplied according to the customers requirements.

Flachbahnregler Mono/Stereo, mit /ohne symmetrischen Insert

INHALT**Seite**

1.	Bedienungselemente.....	2
2.	Symmetrierverstärker	2
3.	Technische Daten der Baugruppe.....	3
5.	Schemateil	5

GELTUNGSBEREICH

Die vorliegenden Informationen gelten für folgende Baugruppen:

	<u>Insert unsym.</u>	<u>Insert symmetrisch</u>
Mono-Fader "A"	1.911.110.83	1.911.112.83
Stereo-Fader "A"	1.911.120.84	1.911.122.84

FADER "A"

1. Bedienungselemente

- Regler** Flachbahnregler mit Conductiv-Plastic-Bahn. Für den Faderstart ist in der Kontaktbahn ein Faderendkontakt eingebaut, der vom Abtaster geschlossen wird. Diese Bauart kommt ohne Mikroschalter und Schalterpunkteinstellung aus (s. unten). Zur Erhaltung einer einwandfreien mechanischen und elektrischen Funktion ist der Flachbahnregler bei Bedarf zu reinigen und zu ölen. Eine ausführliche Anleitung sowie alle notwendigen Utensilien sind als 'Studer Fader Pflege Kit' unter der Bestellnummer 20.020.001.77 erhältlich.
- PFL Taste** Die PFL- und P-Solo-Tasten sind gegenseitig elektronisch gekoppelt. Ist eine der beiden Tasten aktiviert, wird sie automatisch beim Drücken der andern ausgeschaltet. Die Vorhörtaste (PFL = Pre Fader Listening) ist als Impulstaste mit elektronischer Umschaltung und LED-Anzeige ausgeführt. Sie schaltet das Audiosignal vor dem Flachbahnregler auf die Vorhørsammelschiene. Wird auf der Leiterplatte die Brücke X---Z eingelötet (vgl. Schema: Option a), so ist die PFL-Funktion nur bei geschlossenem Fader möglich. In der Grundausführung ist keine Brücke eingebaut. Das PFL-Signal wird also nicht durch den Fader beeinflusst.
- P Solo Taste** Die Abhörtaste 'Positional Solo' (Impulstaste mit elektronischer Umschaltung und LED-Anzeige) schaltet das Audiosignal nach Fader und Panorama-Regler auf die Vorhørsammelschiene.
- Signalstromkreis** Der Flachbahnregler ist mit einem Schalter versehen, der beim Öffnen des Reglers ein Signal an die logische Steuerung gibt. Abhängig von der Stellung der Schalter Mute, Eingangswähler, Summenwahl, Summenregler und eventuell Mic-Cut entsteht am Ausgang je ein Faderstartsignal pro Eingang Mic, Line und Tape.

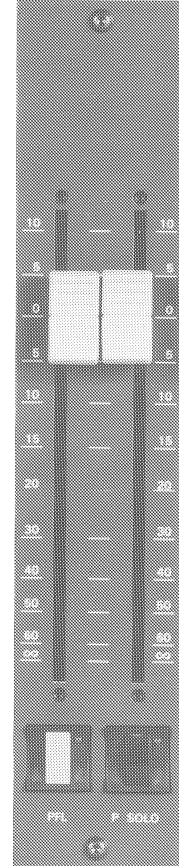

2. Symmetrierverstärker

1.911.112
1.911.122

Der Symmetrierverstärker dient der Adaptation des Insert-Ein- und Ausgangs an asymmetrische Peripheriegeräte. Pro Kanal ist dazu ein Verstärker mit asymmetrischem Eingang und trafolem, symmetrischem Ausgang sowie ein Verstärker mit trafolem, symmetrischem Eingang und asymmetrischem Ausgang vorgesehen. Diese Anordnung stellt asymmetrische Insert- Ein- und Ausgänge zusätzlich zu den symmetrischen Anschlüssen zur Verfügung.

**Technische Daten
Symmetrierverstärker:**
Allgemein

Frequenzgang	30 Hz...16kHz $\pm 0,5$ dB
Klirrfaktor	< 80 dB
Fremdspannungsabstand	100 dB
Verstärkung (asym. \rightarrow sym.)	6 dB
Dämpfung (sym. \rightarrow asym.)	6 dB

Verstärkerteil 1

Eingang:	unsymmetrisch
Eingangsimpedanz	> 10 kOhm
Max. Eingangspegel	+20 dBu
Ausgang:	symmetrisch, ohne Trafo
Ausgangsimpedanz	< 50 Ohm
Max. Last	> 600 Ohm
Max. Ausgangspegel	+24 dBu

Verstärkerteil 2

Eingang:	symmetrisch, ohne Trafo
Eingangsimpedanz	> 10 kOhm
Max. Eingangspegel	+24 dBu
Ausgang:	unsymmetrisch
Ausgangsimpedanz	< 100 Ohm
Max. Ausgangspegel	+20 dBu
Max. Lastwiderstand	> 1 kOhm

3. Technische Daten der Baugruppe

Elektrisch:	Stromaufnahme maximal:	<u>1.911.110</u>	<u>1.911.112</u>	<u>1.911.120</u>	<u>1.911.122</u>
	Speisung $\pm 15V$	$\approx 10mA$	$\approx 20mA$	$\approx 20mA$	$\approx 45mA$
	Speisung $-6V$	$\approx 15mA$	$\approx 15mA$	$\approx 15mA$	$\approx 15mA$
Mechanisch:	Masse Frontschild:	40,4mm x 210mm			
	Tiefe:	129mm			
Audiodaten:	Siehe Kapitel 1 "Allgemeines"				

Mono/stereo fader, with/without balanced insert

CONTENTS

page

1.	Operator controls	2
2.	Balancing amplifier	2
3.	Technical data of the module	3
4.	Circuit diagrams	5

VALIDITY

This information applies to the following modules:

	<u>Insert, unbalanced</u>	<u>Insert, balanced</u>
Mono fader "A"	1.911.110.83	1.911.112.83
Stereo fader "A"	1.911.120.84	1.911.122.84

FADER "A"

1. Operator controls

- Fader** Linear fader with conductive plastic strip. A fader contact, built into the fader strip of the linear fader is closed by the wiper when a fader start is performed. This design eliminates the need for a microswitch and switch point alignment (see below). In order to maintain proper mechanical and electrical function, the fader should be cleaned and oiled as required. Detailed instructions and the required utensils are contained in the 'Studer fader service kit', part No. 20.020.001.77.
- PFL key** The PFL key and the P-Solo key are electronically interlocked. If either of these two keys is activated, the other is automatically deactivated. The prefader listening (PFL) key is implemented as a momentary-action push button with electronic changeover and a pilot LED. It connects the prefader audio signal to the prelistening bus. If the X--Z Jumper is soldered into the circuit board (see circuit diagram: option a), the PFL function is only enabled when the fader is closed. This jumper is not installed in the standard version, i.e. the PFL signal is not influenced by the fader.
- P Solo key** The 'Positional Solo' key (momentary-action push button with electronic changeover and pilot LED) connects the audio signal after the fader and the panorama potentiometer to the prelistening bus.
- Signal circuit** The fader is equipped with a switch that outputs a signal to the logic control when the fader is opened. Depending on the switch settings mute, input selector, master selection, master fader, and possibly Mic-Out, a fader start signal for each mic, line, and tape input becomes available on the output.

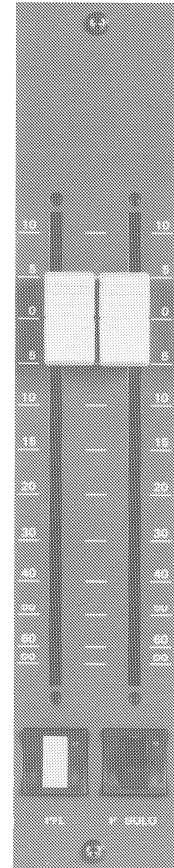

2. Balancing amplifier

1.912.112
1.912.122

The balancing amplifier is used for adapting the insert input and output to unbalanced peripherals. For each channel an amplifier with unbalanced input and as well as an amplifier with transformerless, balanced input and unbalanced output are available (Fig. 2). This arrangement makes unbalanced insert inputs and outputs available in addition to the balanced outputs.

Technical data
Balancing amplifier:General

Frequency response	30 Hz...16 kHz ± 0.5 dB
Distortion	< 80 dB
Signal-to-noise ratio	100 dB
Gain (unbal. \rightarrow bal.)	6 dB
Attenuation (bal. \rightarrow unbal.)	6 dB

Amplifier section 1

Input:	unbalanced
Input impedance	> 10 kohm
Max. input level	+ 20 dBu
Output:	balanced, transformerless
Output impedance	< 50 ohm
Max. load	> 600 ohm
Max. output level	+ 24 dBu

Amplifier section 2

Input:	balanced, transformerless
Input impedance	> 10 kohm
Max. input level	+ 24 dBu
Output:	unbalanced
Output impedance	< 100 ohm
Max. output level	+ 20 dBu
Max. load impedance	> 1 kohm

3. Technical data of the modules

Electrical:	Power consumption, max.:	<u>1.911.110</u>	<u>1.911.112</u>	<u>1.911.120</u>	<u>1.911.122</u>
	± 15 V supply	≈ 10 mA	≈ 20 mA	≈ 20 mA	≈ 45 mA
	-6 V supply	≈ 15 mA	≈ 15 mA	≈ 15 mA	≈ 15 mA
Mechanical:	Front panel dimensions:	40.4 mm x 210 mm			
	Depth:	129 mm			
Audio data:	See Section 1, "General"				

4. Circuit diagrams / Schemateil

Monofader MkII 1.911.110

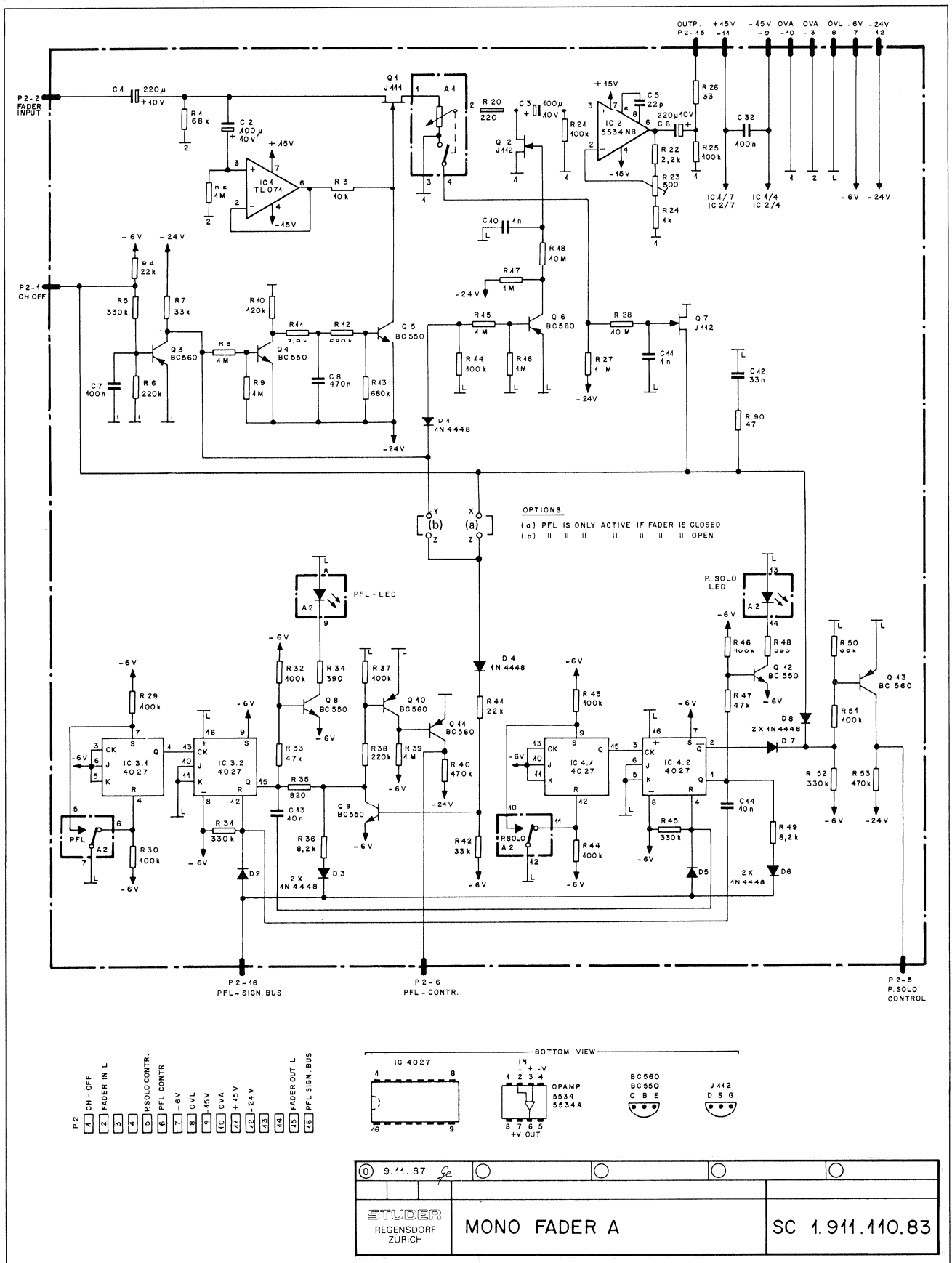

FADER "A"

Monofader MkII 1.911.110 / 112 (with - without balanced insert / mit - ohne sym. Insert)

Ad	POS.	REF.No.	DESCRIPTION	MANUFACTURER
01	A.....1	1.960.011.00	mono fader	St
	A.....1	1.960.011.81	mono fader	St
	A.....2	1.911.001.00	pushbutton board N-N	St
	C.....1	59.22.3221	220 uF 10V EL	R....31 57.11.4334 330 kOhm
	C.....2	59.22.3101	100 uF 10V EL	R....32 57.11.4104 100 kOhm
	C.....3	59.22.3101	100 uF 10V EL	R....33 57.11.4473 47 kOhm
	C.....5	59.34.2220	22 pF CER	R....34 57.11.4391 390 Ohm
	C.....6	59.22.3221	220 uF 10V EL	R....35 57.11.4821 820 Ohm
	C.....7	59.06.0104	100 nF PE	R....36 57.11.4822 8.2 kOhm
	C.....8	59.06.0474	470 nF PE	R....37 57.11.4104 100 kOhm
	C.....9	59.06.0332	33 nF PE	R....38 57.11.4224 220 kOhm
	C.....10	59.06.0102	1 nF PE	R....39 57.11.4105 1 MOhm
	C.....11	59.06.0102	1 nF PE	R....40 57.11.4474 470 kOhm
	C.....12	59.06.0333	33 nF PE	R....41 57.11.4223 22 kOhm
	C.....13	59.06.0103	10 nF PE	R....42 57.11.4333 33 kOhm
	C.....14	59.06.0103	10 nF PE	R....43 57.11.4104 100 kOhm
	C.....15	59.22.3101	100 uF 10V EL	R....44 57.11.4104 100 kOhm
	C.....16	59.34.4101	100 pF CER	R....45 57.11.4334 330 kOhm
	C.....17	59.22.3101	100 uF 10V EL	R....46 57.11.4104 100 kOhm
	C.....18	59.22.3101	100 uF 10V EL	R....47 57.11.4473 47 kOhm
	C.....19	59.22.3221	220 uF 10V EL	R....48 57.11.4391 390 Ohm
	C.....20	59.22.3221	220 uF 10V EL	R....49 57.11.4822 8.2 kOhm
	C.....21	59.05.1681	680 pF 1% PP	R....50 57.11.4683 68 kOhm
	C.....22	59.05.1681	680 pF 1% PP	R....51 57.11.4104 100 kOhm
	C.....23	59.05.1681	680 pF 1% PP	R....52 57.11.4334 330 kOhm
	C.....24	59.05.1681	680 pF 1% PP	R....53 57.11.4474 470 kOhm
	C.....25	59.22.3101	100 uF 10V EL	R....54 57.11.4471 470 Ohm
	C.....26	59.22.3101	100 uF 10V EL	R....55 57.11.4223 22 kOhm
	C.....27	59.34.4101	100 pF CER	R....56 57.11.4473 47 kOhm
	C.....28	59.34.4101	100 pF CER	R....57 57.11.3272 2.7 kOhm 1%
	C.....29	59.22.3221	220 uF 10V EL	R....58 57.11.3302 3 kOhm 1%
	C.....30	59.06.0223	22 nF PE	R....59 57.11.3473 47 kOhm 1%
	C.....31	59.06.0223	22 nF PE	R....60 57.11.3302 3 kOhm 1%
	C.....32	59.06.0104	100 nF PE	R....61 57.11.4474 470 kOhm 2%
	D.....1	50.04.0125	1N4448	R....62 57.11.3302 3 kOhm 1%
	D.....2	50.04.0125	1N4448	R....63 57.11.3150 15 Ohm 1%
	D.....3	50.04.0125	1N4448	R....64 57.11.3302 3 kOhm 1%
	D.....4	50.04.0125	1N4448	R....65 57.11.3473 47 kOhm 1%
	D.....5	50.04.0125	1N4448	R....66 57.11.3272 2.7 kOhm 1%
	D.....6	50.04.0125	1N4448	R....67 57.11.3302 3 kOhm 1%
	D.....7	50.04.0125	1N4448	R....68 57.11.3302 3 kOhm 1%
	D.....8	50.04.0125	1N4448	R....69 57.11.4474 470 kOhm 2%
	IC.....1	50.09.0103	TI071CP J-FET-op.amp. TI	R....70 57.11.3150 15 Ohm 1%
	IC.....2	50.05.0244	5534 law noise op.amp. RA: 5534ANB, Sig: NE5534AN	R....71 57.11.3302 3 kOhm 1%
	IC.....3	50.07.0027	4027 IC C-MOS Mot: MC14027BCP, RCA:CD4027BE	R....72 57.11.3302 3 kOhm 1%
	IC.....4	50.07.0027	4027 Ph: HEF4027BP, SGS: HCF4027BEY	R....73 57.11.3302 3 kOhm 1%
	IC.....5	50.09.0105	NE5532 dual op. amp. *	R....74 57.11.3302 3 kOhm 1%
	IC.....6	50.09.0105	NE5532 dual op. amp. *	R....75 57.11.3302 3 kOhm 1%
	P.....1	54.01.0359	2*16 pin eurocard connector, male *	R....76 57.11.3302 3 kOhm 1%
	P.....2	54.11.2007	2*8 pin 1/2-eurocard connector, male	R....77 57.11.3302 3 kOhm 1%
	Q.....1	50.03.0216	J111 N-J-FET NS, Mot, Six	R....78 57.11.3302 3 kOhm 1%
	Q.....2	50.03.0350	J112 N-J-FET Mot	R....79 57.11.3689 6.8 Ohm 1%
	Q.....3	50.03.0496	BC560 PNP, Ic<100mA, B>290 any	R....80 57.11.3689 6.8 Ohm 1%
	Q.....4	50.03.0497	BC550 NPN, Ic<100mA, B>290 any	R....81 57.11.3152 1.5 kOhm 1%
	Q.....5	50.03.0497	BC550 NPN, Ic<100mA, B>290 any	R....82 57.11.3152 1.5 kOhm 1%
	Q.....6	50.03.0496	BC560 PNP, Ic<100mA, B>290 any	R....83 57.11.3392 3.9 kOhm 1%
	Q.....7	50.03.0350	J112 N-J-FET Mot	R....84 57.11.3392 3.9 kOhm 1%
	Q.....8	50.03.0497	BC550 NPN, Ic<100mA, B>290 any	R....85 57.11.3272 2.7 kOhm 1%
	Q.....9	50.03.0497	BC550 NPN, Ic<100mA, B>290 any	R....86 57.11.3272 2.7 kOhm 1%
	Q.....10	50.03.0496	BC560 PNP, Ic<100mA, B>290 any	R....87 57.11.4223 22 kOhm
	Q.....11	50.03.0496	BC560 PNP, Ic<100mA, B>290 any	R....88 57.11.4330 33 Ohm
	Q.....12	50.03.0497	BC550 NPN, Ic<100mA, B>290 any	R....89 57.11.4471 470 Ohm
	Q.....13	50.03.0496	BC560 PNP, Ic<100mA, B>290 any	R....90 57.11.4470 47 Ohm
	R.....1	57.11.4683	68 kOhm	
	R.....2	57.11.4105	1 MOhm	
	R.....3	57.11.4103	10 kOhm	
	R.....4	57.11.4223	22 kOhm	
	R.....5	57.11.4334	330 kOhm	
	R.....6	57.11.4224	220 kOhm	
	R.....7	57.11.4333	33 kOhm	
	R.....8	57.11.4105	1 MOhm	
	R.....9	57.11.4105	1 MOhm	
	R.....10	57.11.4124	120 kOhm	
	R.....11	57.11.4392	3.9 kOhm	
	R.....12	57.11.4684	680 kOhm	
	R.....13	57.11.4684	680 kOhm	
	R.....14	57.11.4104	100 kOhm	
	R.....15	57.11.4105	1 MOhm	
	R.....16	57.11.4105	1 MOhm	
	R.....17	57.11.4105	1 MOhm	
	R.....18	57.11.5106	10 MOhm	
	R.....20	57.11.4221	220 Ohm	
	R.....21	57.11.4104	100 kOhm	
	R.....22	57.11.4222	2.2 kOhm	
	R.....23	58.01.8501	500 Ohm	
	R.....24	57.11.4102	1 kOhm	
	R.....25	57.11.4104	100 kOhm	
	R.....26	57.11.4330	33 Ohm	
	R.....27	57.11.3105	1 MOhm	
	R.....28	57.11.5106	10 MOhm	
	R.....29	57.11.4104	100 kOhm	
	R.....30	57.11.4104	100 kOhm	

This position list is valid for:
 Diese Positionsliste ist gültig für:
 -1.911.110.83 Mono Fader Unit A Mk2
 -1.911.112.83 Mono Fader Unit A Mk2 / Bal.Amp.

* = only/nur 1.911.112.83
 CER = ceramic, EL = electrolytic, PE = polyester

MANUFACTURER: Mot=Motorola, NS=National Semiconductors, Ph=Philips,
 Ra=Raytheon, SGS=SGS/Ates, Sig=Signetics,
 Six=Siliconics, St=Studer, TI=Texas Instruments

HISTORY:

20.3.90 (1) New Fader 1.960.011.81
 1.911.110.83 MONO FADER UNIT A Mk2 TA 89/10/1700
 1.911.110.83 MONO FADER UNIT A Mk2 HOR90/03/2001

Monofader MkII 1.911.110 / 112 (with - without balanced insert / mit - ohne sym. Insert)

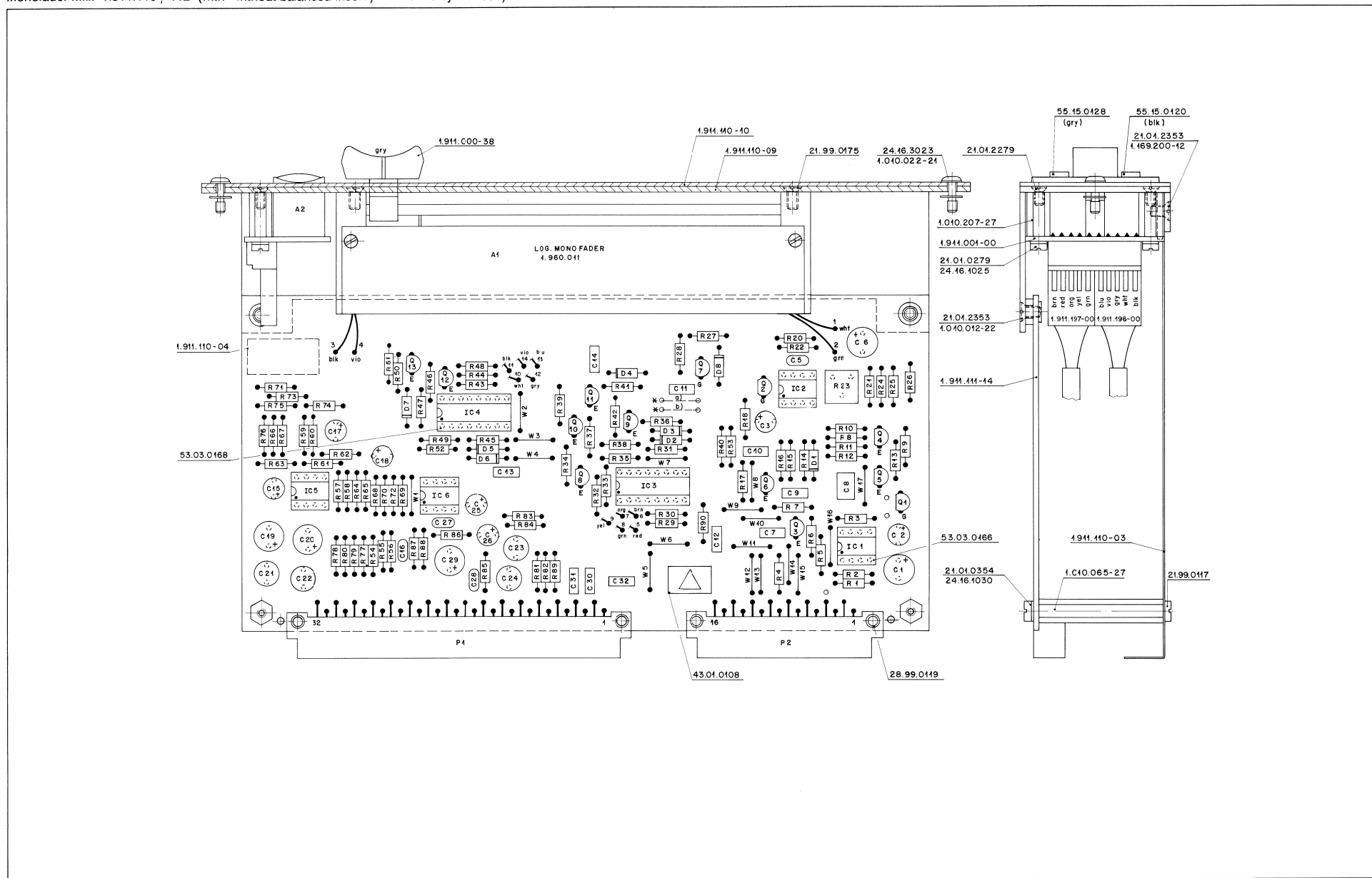

FADER "A"

Monofader MkII 1.911.112 (balanced insert / symmetrischer Insert)

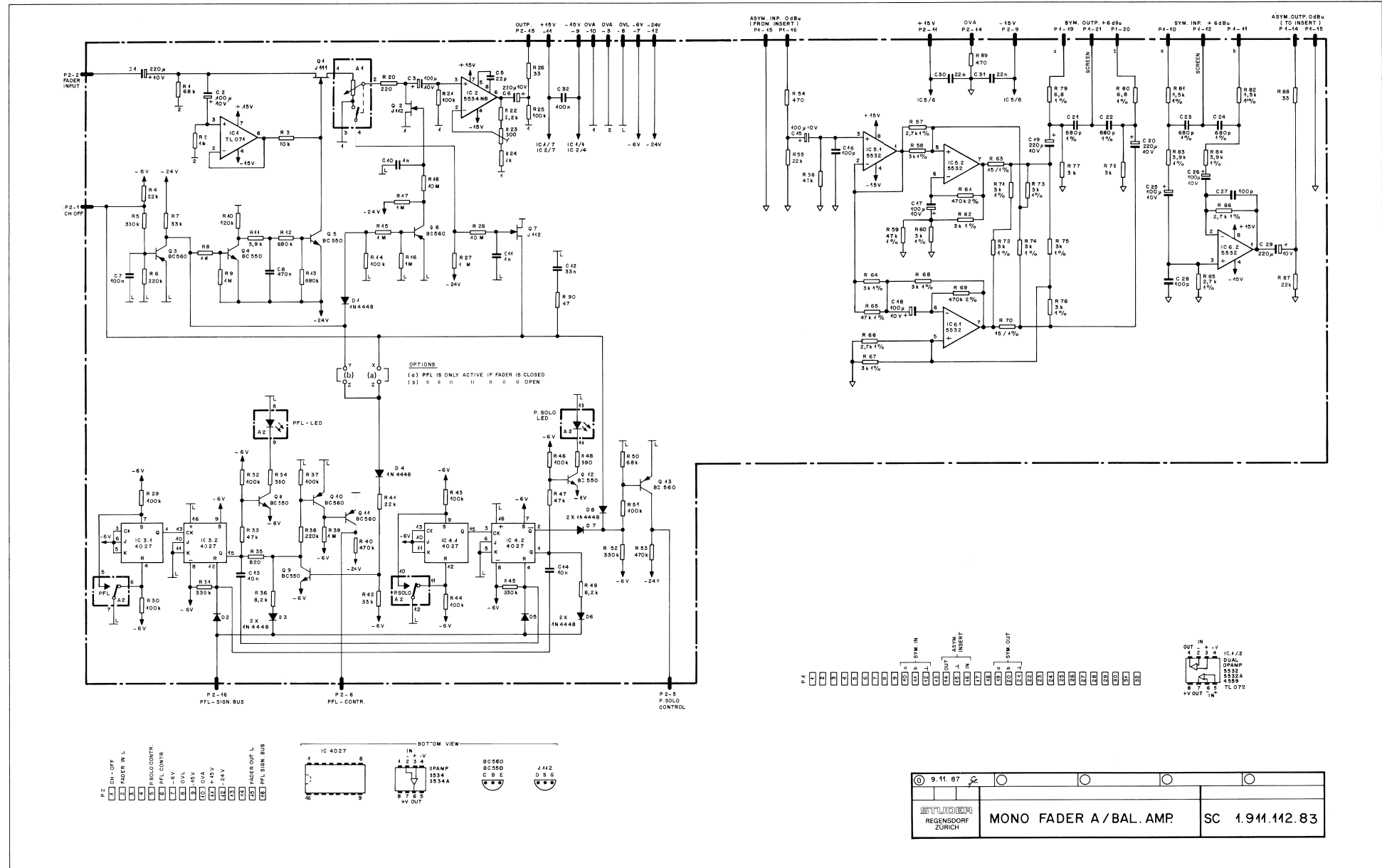

9.11.87		
STUDER REGENSDORF ZURICH	MONO FADER A/BAL. AMP	SC 1.911.112.83

Stereofader 1.911.120

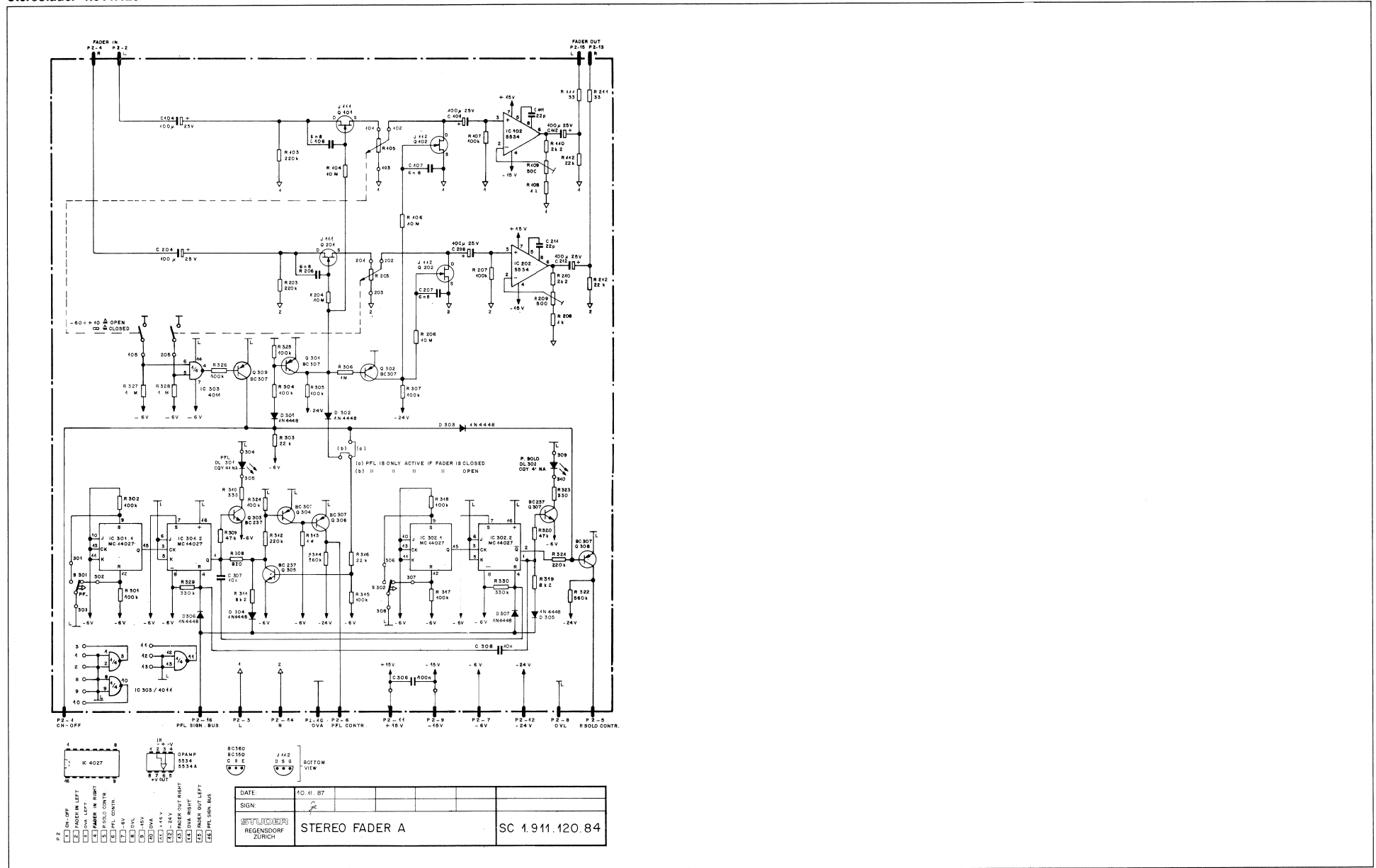

FADER "A"

Stereofader 1.911.120

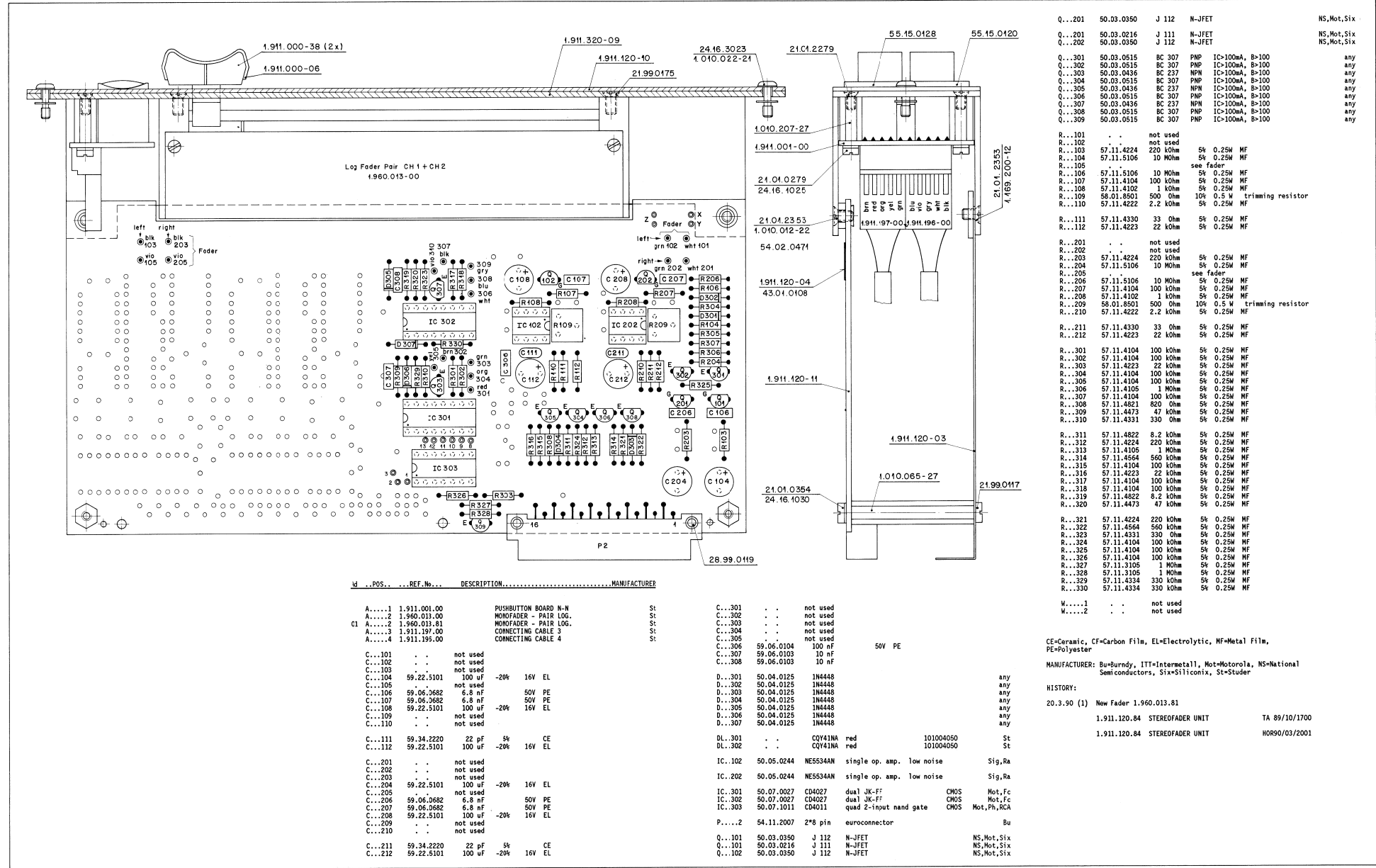

Q...	REF. No...	DESCRIPTION	MANUFACTURER
Q...201	50.03.0350	J 112	N-JFET
Q...201	50.03.0216	J 111	N-JFET
Q...202	50.03.0350	J 112	N-JFET
Q...301	50.03.0515	BC 307	PNP IC>100mA, B=100
Q...302	50.03.0515	BC 307	PNP IC>100mA, B=100
Q...303	50.03.0436	BC 237	NPN IC>100mA, B=100
Q...304	50.03.0515	BC 307	PNP IC>100mA, B=100
Q...305	50.03.0436	BC 237	NPN IC>100mA, B=100
Q...306	50.03.0515	BC 307	PNP IC>100mA, B=100
Q...307	50.03.0436	BC 237	NPN IC>100mA, B=100
Q...308	50.03.0515	BC 307	PNP IC>100mA, B=100
Q...309	50.03.0515	BC 307	PNP IC>100mA, B=100
R...101	.	not used	
R...102	.	not used	
R...103	57.11.4224	220 kOhm	5% 0.25W MF
R...104	57.11.5106	10 MOhm	5% 0.25W MF
R...105	57.11.5106	10 MOhm	see fader
R...106	57.11.5106	10 MOhm	5% 0.25W MF
R...107	57.11.4104	100 kOhm	5% 0.25W MF
R...108	57.11.4102	1 kOhm	5% 0.25W MF
R...109	58.01.8501	500 Ohm	10% 0.5 W trimming resistor
R...110	57.11.4222	2.2 kOhm	5% 0.25W MF
R...111	57.11.4330	33 Ohm	5% 0.25W MF
R...112	57.11.4223	22 kOhm	5% 0.25W MF
R...201	.	not used	
R...202	.	not used	
R...203	57.11.4224	220 kOhm	5% 0.25W MF
R...204	57.11.5106	10 MOhm	5% 0.25W MF
R...205	.	see fader	
R...206	57.11.5106	10 MOhm	5% 0.25W MF
R...207	57.11.4104	100 kOhm	5% 0.25W MF
R...208	57.11.4102	1 kOhm	5% 0.25W MF
R...209	58.01.8501	500 Ohm	10% 0.5 W trimming resistor
R...210	57.11.4222	2.2 kOhm	5% 0.25W MF
R...211	57.11.4330	33 Ohm	5% 0.25W MF
R...212	57.11.4223	22 kOhm	5% 0.25W MF
R...301	57.11.4104	100 kOhm	5% 0.25W MF
R...302	57.11.4104	100 kOhm	5% 0.25W MF
R...303	57.11.4223	22 kOhm	5% 0.25W MF
R...304	57.11.4104	100 kOhm	5% 0.25W MF
R...305	57.11.4104	100 kOhm	5% 0.25W MF
R...306	57.11.4105	1 MOhm	5% 0.25W MF
R...307	57.11.4104	100 kOhm	5% 0.25W MF
R...308	57.11.4821	820 Ohm	5% 0.25W MF
R...309	57.11.4473	47 kOhm	5% 0.25W MF
R...310	57.11.4331	330 Ohm	5% 0.25W MF
R...311	57.11.4822	8.2 kOhm	5% 0.25W MF
R...312	57.11.4224	220 kOhm	5% 0.25W MF
R...313	57.11.4105	1 MOhm	5% 0.25W MF
R...314	57.11.4564	560 kOhm	5% 0.25W MF
R...315	57.11.4104	100 kOhm	5% 0.25W MF
R...316	57.11.4223	22 kOhm	5% 0.25W MF
R...317	57.11.4104	100 kOhm	5% 0.25W MF
R...318	57.11.4104	100 kOhm	5% 0.25W MF
R...319	57.11.4822	8.2 kOhm	5% 0.25W MF
R...320	57.11.4473	47 kOhm	5% 0.25W MF
R...321	57.11.4224	220 kOhm	5% 0.25W MF
R...322	57.11.4564	560 kOhm	5% 0.25W MF
R...323	57.11.4331	330 Ohm	5% 0.25W MF
R...324	57.11.4104	100 kOhm	5% 0.25W MF
R...325	57.11.4104	100 kOhm	5% 0.25W MF
R...326	57.11.4104	100 kOhm	5% 0.25W MF
R...327	57.11.3105	1 MOhm	5% 0.25W MF
R...328	57.11.3105	1 MOhm	5% 0.25W MF
R...329	57.11.4334	330 kOhm	5% 0.25W MF
R...330	57.11.4334	330 kOhm	5% 0.25W MF
W...1	.	not used	
W...2	.	not used	

Stereofader 1.911.122(balanced insert/symmetrischer Insert)

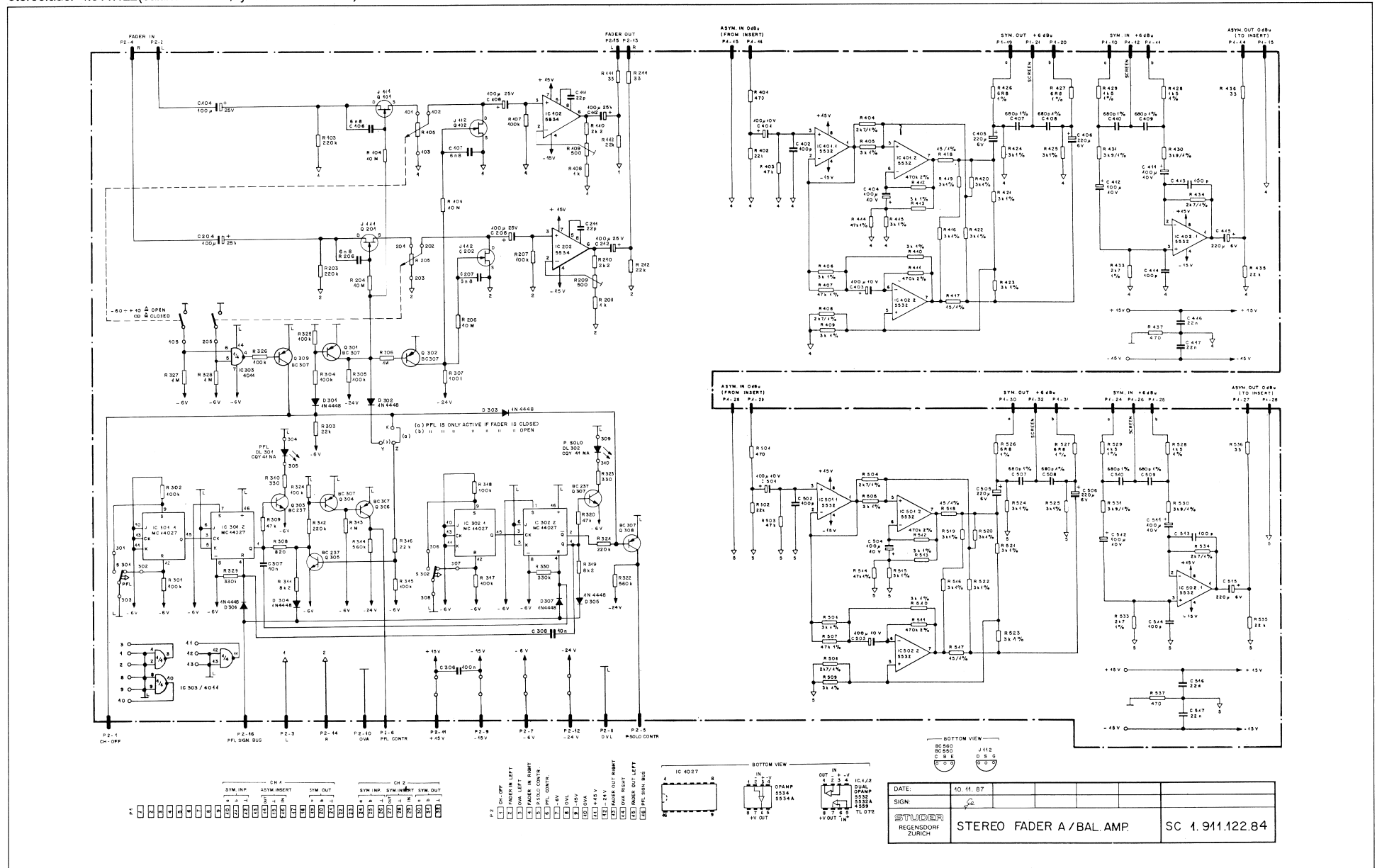

FADER "A"

Stereofader 1.911.122(balanced insert/symmetrischer Insert)

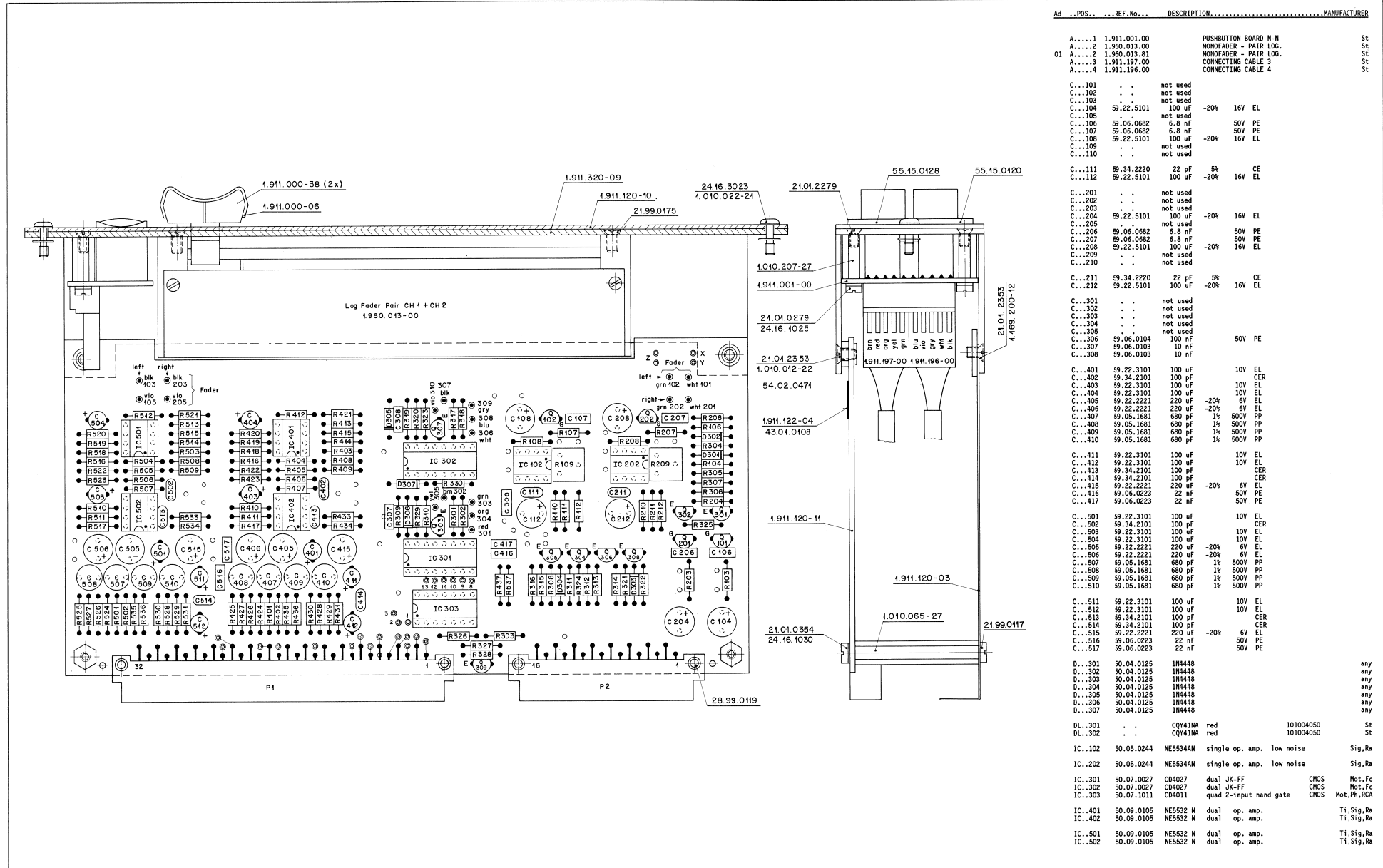

Master Unit Mk II

INHALT	Seite
1. Allgemeines	2
2. Blockschaltbild	2
3. Flachbahnregler	3
4. PFL – Taste	3
5. PSolo – Taste.....	4
6. Limiter.....	4
7. Pegeldiagramm	4
8. Schemateil	5

GELTUNGSBEREICH

Die folgenden Informationen beziehen sich auf die Einschübe mit den Nummern:

	<u>ohne Limiter</u>	<u>mit Limiter</u>
Mono Master Unit Mk II	1.911.315	1.911.317
Dual Master Unit Mk II	1.911.325	1.911.335

Die verwendeten Prints tragen die Nummern 1.911.323 (Kanal 1 bzw. Mono) und 1.911.324 (Kanal 2).

MASTER UNIT MKII

1. Allgemeines

Der STUDER Summenregler ist einheitlich aus einem Summierverstärker in Null-Ohm-Technik, einem Flachbahnregler, einer Vorhörtaste sowie einem Leitungsverstärker mit Ausgangstransformator aufgebaut. Die Ausführungen mit Limiteranschluss verfügen zusätzlich über den Kippschalter 'Limiter on'. Er aktiviert die Dual Limiter - Europakarte 1.915.700, die im AF Insert der Summeneinheit eingeschleuft wird. Bei den Dual Master Einheiten können die beiden Limiterkanäle durch den Kippschalter 'Link' gekoppelt werden. Das Summensignal kann als 'PF out' (pre fader) vor oder als 'AF out' (after fader) nach dem Flachbahnregler abgegriffen und wieder eingespeist werden. Pro Kanal ist zudem ein vollkommen unabhängiger, elektronisch symmetrierter Verstärker vorhanden, der je nach Anwendung für die Bereitstellung symmetrischer Ein- und Ausgänge verschaltet werden kann. Neben den asymmetrischen Einschleifpunkten ist der 'AF in' symmetrisch ausgeführt.

2. Blockschaltbild

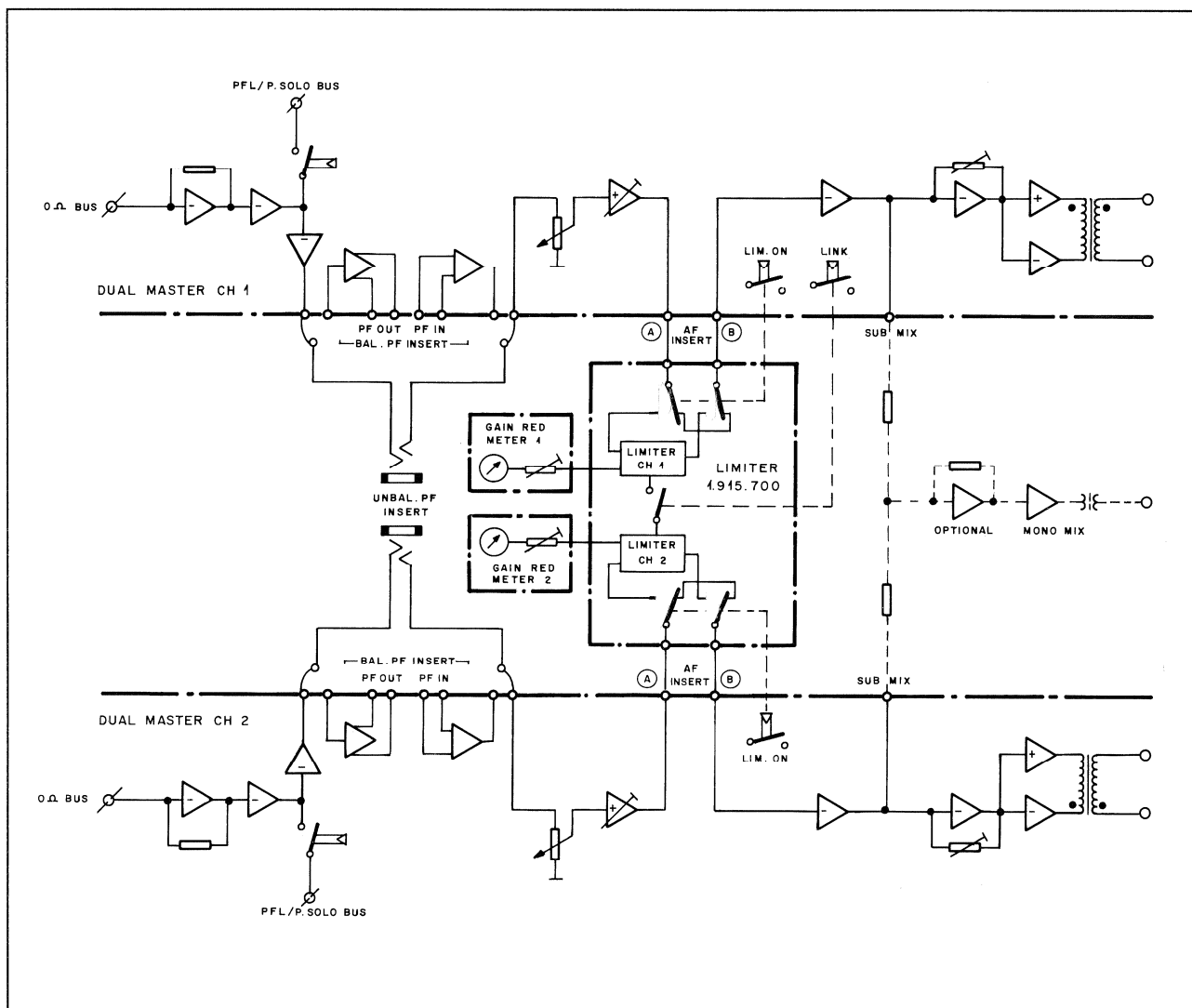

Fig. 1 Das Blockschaltbild zeigt die Version 1.911.335. Bei Ausführungen ohne Limiter wird an dessen Stelle eine Drahtbrücke bestückt. (Verbindung: A ... B)

3. Flachbahnregler

Der Studer Flachbahnregler ist mit einer Widerstandsschicht aus leitendem Kunststoff ausgerüstet, deren logarithmische Widerstandskennlinie engen Toleranzen folgt. Zieht man den Fader zu, so wird mit dem Schleifer ein Fader - Endkontakt in der Widerstandsschicht geschlossen. Durch diese Bauart entfallen Mikroschalter und Schaltpunkt - Einstellungen. Der Faderweg misst 104mm.

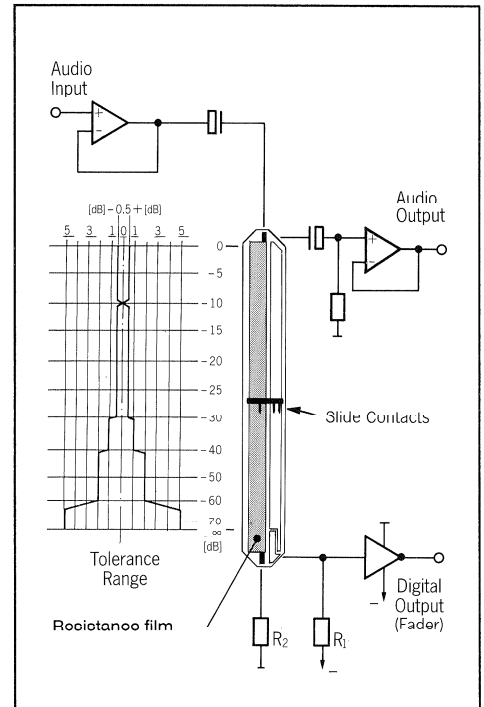

Fig. 2 Schematische Darstellung des Faderschaltkreises mit Toleranzdiagramm der Widerstandsschicht.

4. PFL - Taste

Die PFL- und P-Solo-Tasten sind gegenseitig elektronisch gekoppelt. Ist eine der beiden Tasten aktiviert, wird sie automatisch beim Drücken der andern ausgeschaltet.

Die Vorhörtaste (PFL = Pre Fader Listening) ist als Impulstaste mit elektronischer Umschaltung und LED-Anzeige ausgeführt. Sie schaltet das Audiosignal vor dem Flachbahnregler auf die Vorhørsammelschiene.

Die Optionen 3 und 4 der Tabelle auf dem Schema (S.7) koppeln die PFL Funktion mit der Faderstellung:

Mit der Drahtbrücke PFL ON ist nur bei offenem Fader ein PFL Signal zu hören. Die Brücke PFL OFF schaltet umgekehrt nur bei geschlossenem Fader ein PFL Signal durch.

MASTER UNIT MKII

5. P Solo Taste

Die Abhörtaste 'Positional Solo' (Impulstaste mit elektronischer Umschaltung und LED-Anzeige) schaltet das Audiosignal nach Fader und Panorama-Regler auf die Vorhørsammelschiene.

6. Limiter

Der Stereo - Summenregler Nr. 1.911.335 ist mit der Limiter - Europakarte Nr. 1.915.700 verbunden. Diese wird für jeden Kanal separat durch den Kippschalter Limiter on aktiviert. Sollen die Limiter beider Kanäle gekoppelt arbeiten, muss der Kippschalter Link betätigt werden. Dies verhindert bei Stereowiedergabe ein Wandern der Schallquellen im Panoramafeld. Auch die Mono Master Unit kann mit einem Limiter ausgerüstet werden. Die Funktion 'Limiter on' wird dann aber über eine zweite Impulstaste mit LED - Anzeige gesteuert. Angaben zum Limiter finden sich im Kapitel 8, Europakarten.

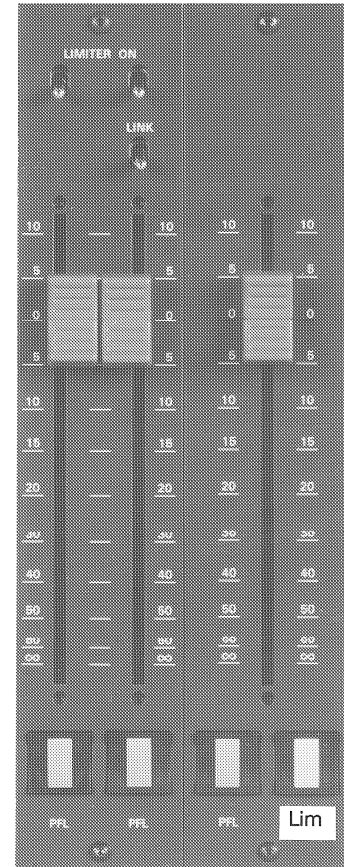

Fig. 3: Dual Master Unit MkII mit Limiter (1.911.335) und Mono Master Unit MkII mit Limiter (1.911.317)

7. Pegeldiagramm

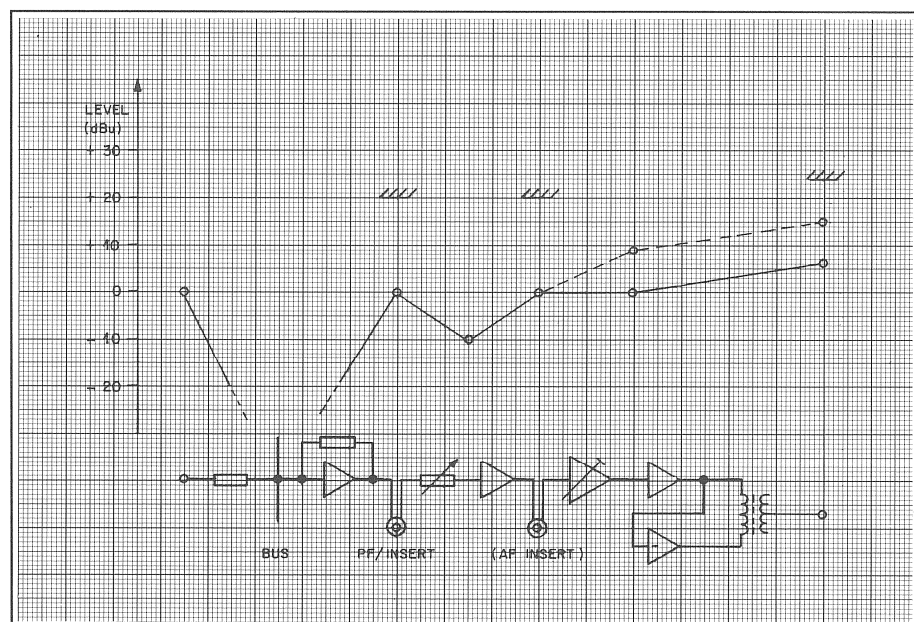

Fig. 4 Pegeldiagramm der Master Unit MkII

Master Unit Mk II

CONTENTS	page
1. General	2
2. Block diagram	2
3. Fader	3
4. PFL key	3
5. PSolo key	4
6. Limiter	4
7. Level diagram	4
8. Circuit diagrams	5

VALIDITY

The following information relates to modules with the numbers:

	<u>Without limiter</u>	<u>With limiter</u>
Mono Master Unit Mk II	1.911.315	1.911.317
Dual Master Unit Mk II	1.911.325	1.911.335

The corresponding circuit boards are numbered as 1.911.323 (mono) and 1.911.323/324 (stereo).

MASTER UNIT MKII

1. General

The STUDER master fader consists of a summing amplifier in zero-ohm technology, a fader, a prefader listening key, as well as a line amplifier with output transformer. Versions with a limiter connector are additionally equipped with a 'Limiter on' toggle switch. It activates the dual EU-standard limiter PCB 1.915.700 which is connected to the AF insert of the master unit. On dual master units, the two limiter channels can be coupled by means of the 'Link' toggle switch. The master signals can be tapped before the fader as 'PF out', or after the fader as 'AF out' and reinserted. Each channel has a fully independent, electronically balanced amplifier which can be wired for balanced input and outputs, as required by the application. In addition to the balanced PF and AF insertion points, also the 'AF in' is implemented with balanced circuits.

2. Block diagram

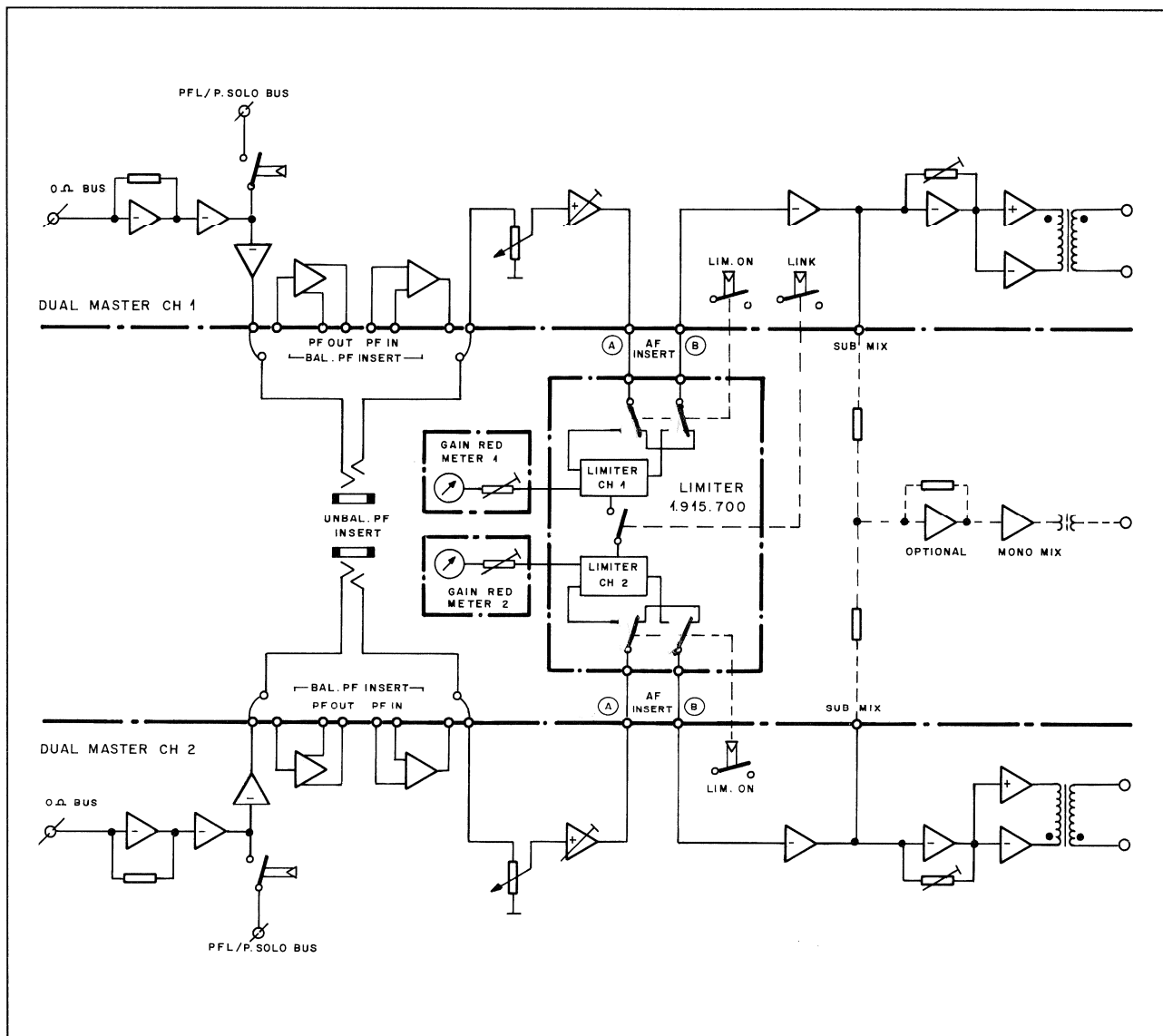

Fig. 1 The block diagram illustrates the version 1.911.335. In versions without a limiter a jumper is inserted in its place (connection: A...B)

3. Linear fader

The Studer linear fader features a resistance film made of conductive plastic whose resistance characteristic is logarithmic within close tolerances. When the fader is being closed, a fader limit contact is closed in the resistance film. This design eliminates the need for a microswitch and switch point alignments.

The fader has a travel of 104 mm.

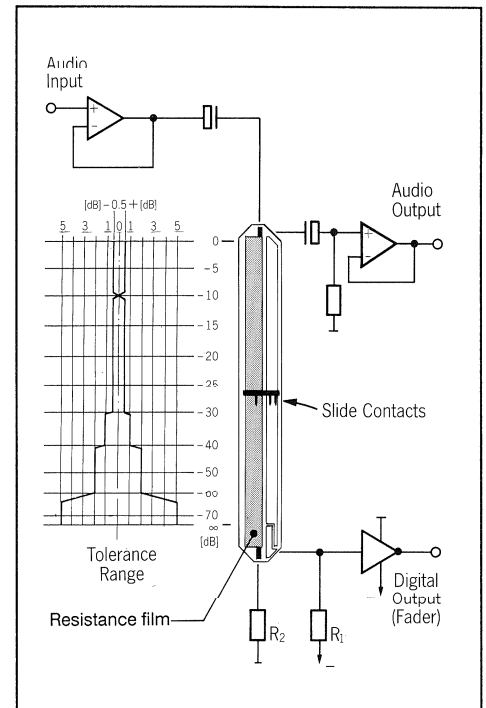

Fig. 2 Schematic representation of the fader circuit with tolerance diagram of the resistance film.

4. PFL key

The PFL key and the P.Solo key are electronically interlocked. If either of these two keys is activated, the other is automatically deactivated.

The prefader listening (PFL) key is implemented as a momentary-action push button with electronic changeover and pilot LED. It connects the prefader audio signal to the prelistening bus.

Options 3 and 4 of the table in the diagram (p.7) couple the PFL function to the fader setting:

With the PFL jumper in the ON position, a PFL signal can only be heard when the fader is open. Conversely, if the PFL jumper is in the OFF position, the PFL signal is only through-connected when the fader is closed.

MASTER UNIT MKII

5. P Solo key

The 'Positional Solo' key (momentary-action push button with electronic changeover and pilot LED) connects the audio signal after the fader and the panorama potentiometer to the prelistening bus.

6. Limiter

The stereo master fader No. 1.911.335 is connected to the EU-standard limiter board 1.915.700. This board is activated separately for each channel by the limiter toggle switch. If the limiters of both channels should work linked mode, the link toggle switch must be actuated. This prevents drifting of the sound sources in the panorama field during stereo reproduction. The mono master unit can also be fitted with a limiter. In this case the 'Limiter on' function is controlled via a second momentary-action push button with pilot LED. The limiter specifications can be found in Section 8, EU-standard boards.

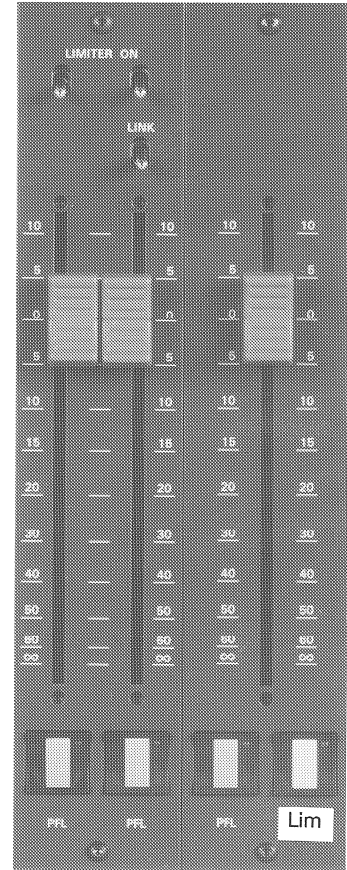

Fig. 3 Dual master unit MkII with limiter (1.911.335) and mono master unit MkII with limiter (1.911.317)

7. Level diagram

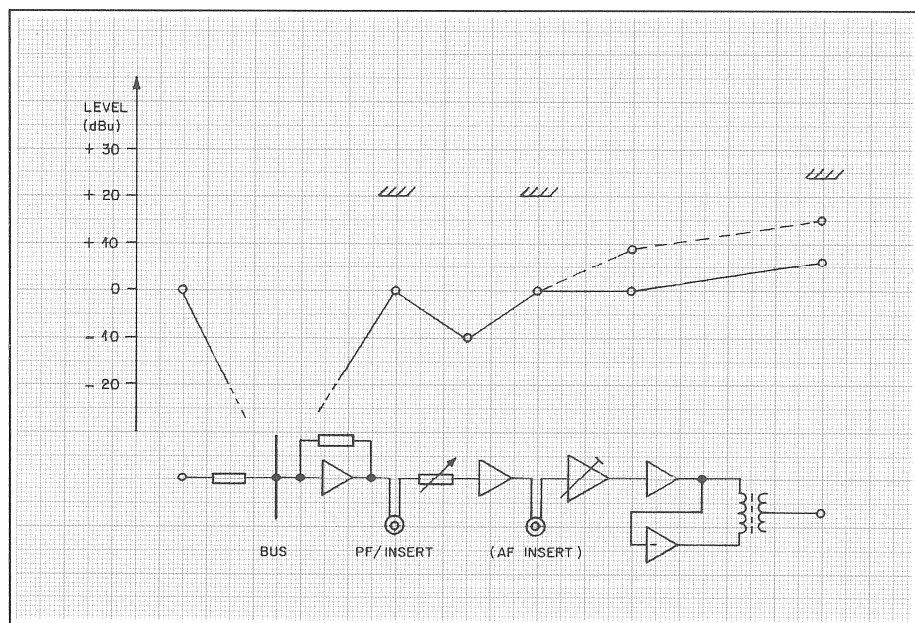
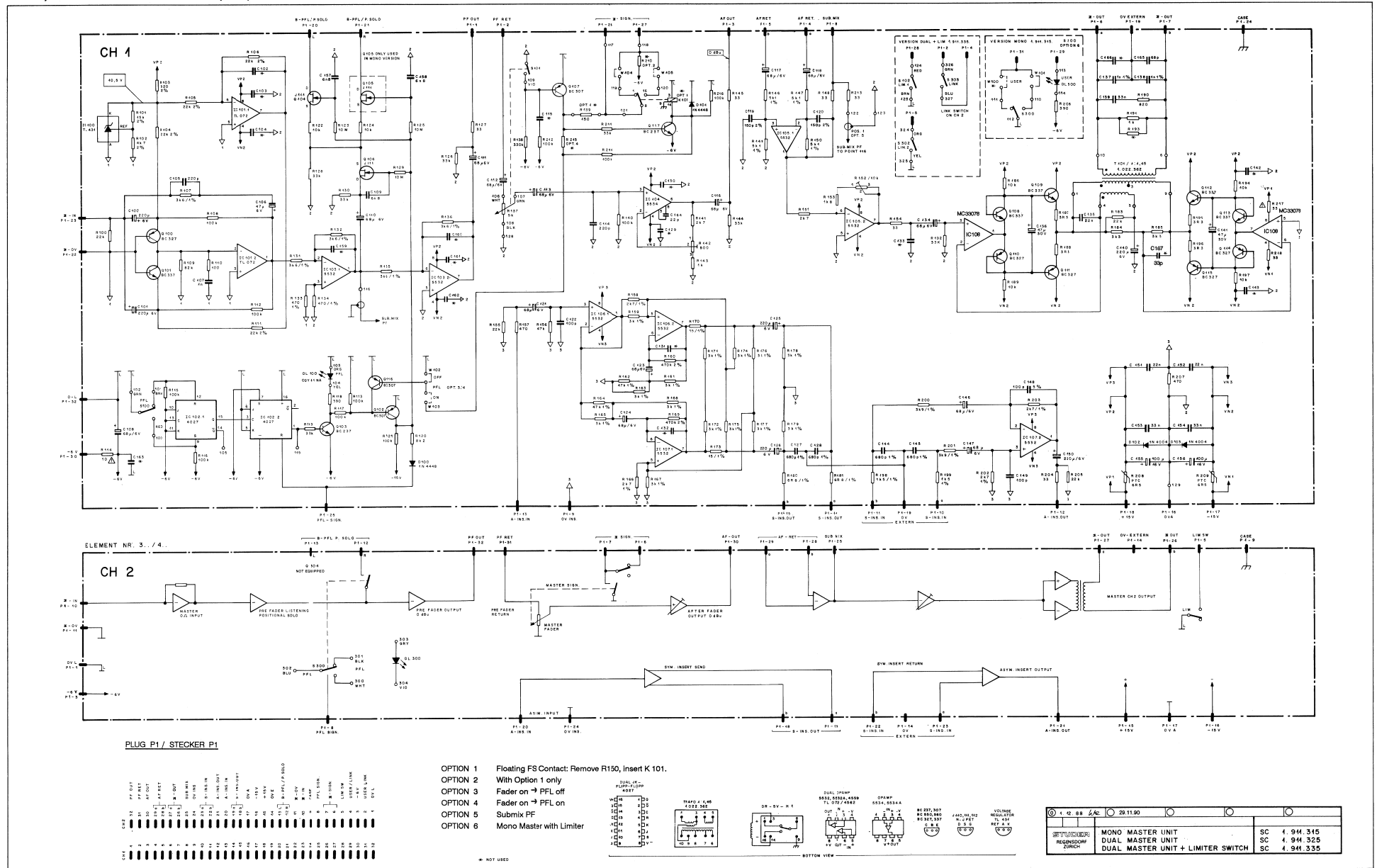

Fig. 4 Level diagram of the master unit MkII

8. Circuit diagrams / Schemateil

Mono / Dual Master Unit 1.911.315/325/335



Mono Master Unit 1.911.315 (1.911.317)

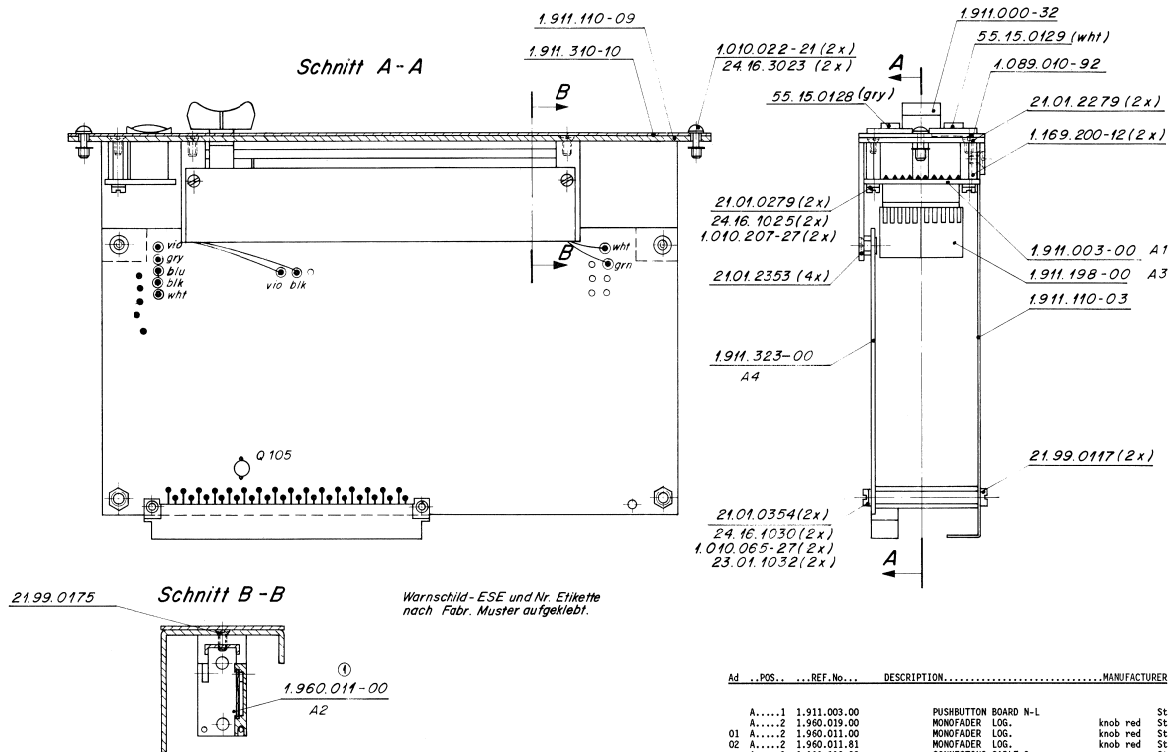

MANUFACTURER: Mot=Motorola, VS=National Semi conductor, Six=Siliconix, St=Studer

HISTORY:

20.3.90 (2) New Fader 1.960.011.81

1.911.315.00 MONO MASTER UNIT TA 87/07/1500

1.911.315.00 MONO MASTER UNIT TA 88/05/0901

1.911.315.00 MONO MASTER UNIT HOR90/03/2002

Dual Master Unit 1.911.325 (1.911.335)

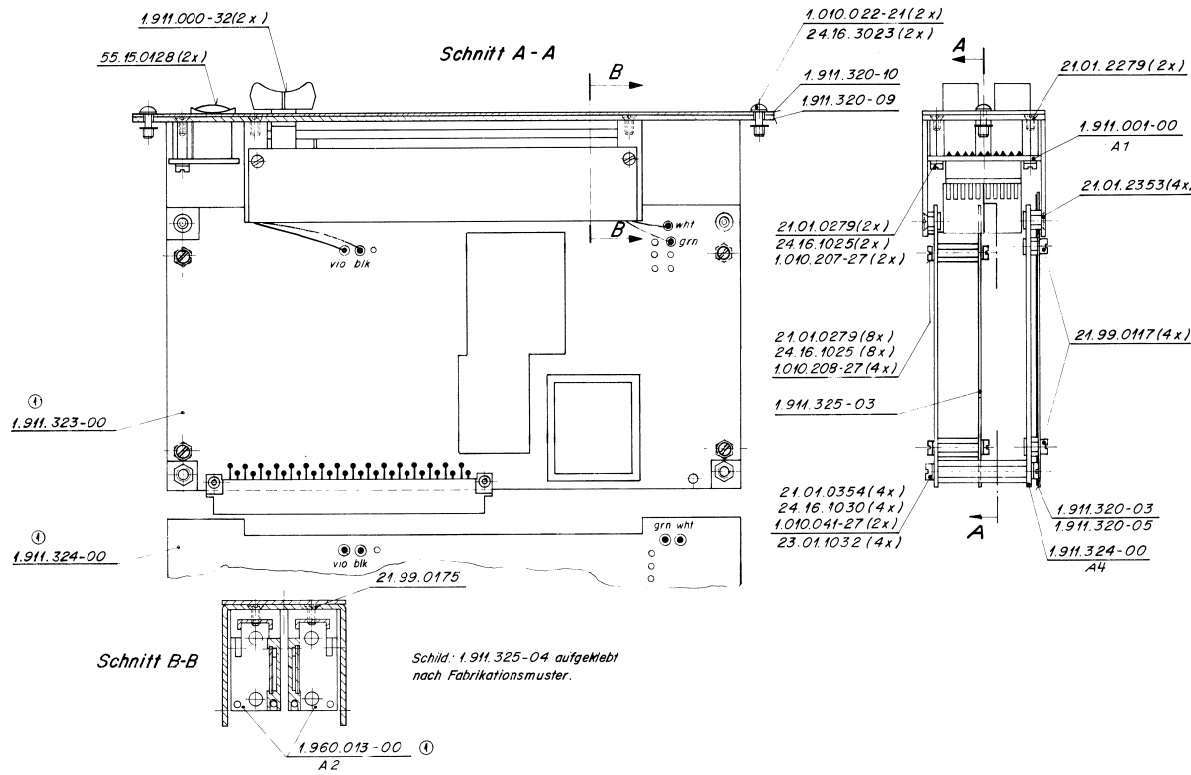

Ad	..POS.	..REF.No.	DESCRIPTION	MANUFACTURER
A.....1		1.911.001.00	PUSHBUTTON BOARD N-N	St
A.....2		1.960.018.00	MONOFADER-PAIR LOG. knob red	St
01 A.....2		1.960.013.00	MONOFADER-PAIR LOG. knob red	St
02 A.....2		1.960.013.81	MONOFADER-PAIR LOG. knob red	St
A.....3		1.911.323.00	MASTER BOARD CH 1	St
A.....4		1.911.324.00	MASTER BOARD CH 2	St

MANUFACTURER: St=Studer

HISTORY:

20.3.90 (2) New Fader 1.960.013.81

1.911.325.00 DUAL MASTER UNIT TA 87/07/1500

1.911.325.00 DUAL MASTER UNIT TA 88/05/0901

1.911.325.00 DUAL MASTER UNIT HOR90/03/2002

Ad	..POS.	..REF.No.	DESCRIPTION	MANUFACTURER
A.....1		1.911.001.00	PUSHBUTTON BOARD N-N	St
A.....2		1.960.018.00	MONOFADER - PAIR LOG. knob red	St
01 A.....2		1.960.013.00	MONOFADER - PAIR LOG. knob red	St
A.....3		1.911.323.00	MASTER BOARD CH 1	St
A.....4		1.911.324.00	MASTER BOARD CH 2	St

S...102 55.01.0111 ON-ON toggle switch

S...202 55.01.0111 ON-ON toggle switch

S...203 55.01.0111 ON-ON toggle switch

MANUFACTURER: St=Studer

1.911.335.00 DUAL MASTER UNIT + LIM SWITCH TA 87/07/1500

1.911.335.00 DUAL MASTER UNIT + LIM SWITCH TA 88/05/0901

Master Board CH1 1.911.323

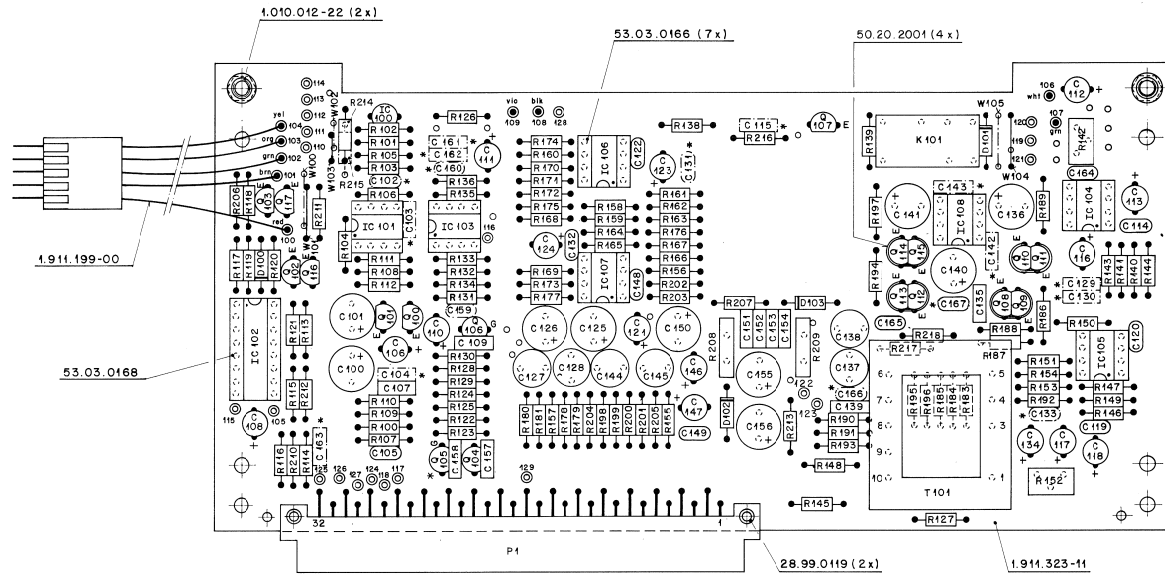

Ad . POS. . . REF.No. . . DESCRIPTION . . . MANUFACTURER

Ad . POS.	REF.No.	DESCRIPTION	MANUFACTURER
Q...104	50.03.0216	J 111 N-JFET	NS,Not,Six
Q...105	not used		see note 2)
Q...106	50.03.0216	J 111 N-JFET	NS,Not,Six
Q...107	50.03.0515	BC 307 PNP B > 100 (BC 557 , BC 560)	any
Q...108	50.03.0516	BC 337 NPN IC max 800mA	match Sie
Q...109	50.03.0516	BC 337 NPN IC max 800mA	match Sie
Q...110	50.03.0625	BC 327 PNP IC max 800mA	match Sie
Q...111	50.03.0625	BC 327 PNP IC max 800mA	match Sie
Q...112	50.03.0516	BC 337 NPN IC max 800mA	match Sie
Q...113	50.03.0516	BC 337 NPN IC max 800mA	match Sie
Q...114	50.03.0625	BC 327 PNP IC max 800mA	match Sie
Q...115	50.03.0625	BC 327 PNP IC max 800mA	match Sie
Q...116	50.03.0515	BC 307 PNP B > 100 (BC 557 , BC 560)	any
Q...117	50.03.0436	BC 237 NPN B > 100 (BC 547 , BC 550)	any
R...100	57.11.4223	22 kOhm	0.25W MF
R...101	57.11.4153	15 kOhm	2% 0.25W MF
R...102	57.11.4472	4.7 kOhm	2% 0.25W MF
R...103	57.11.4821	820 Ohm	2% 0.25W MF
R...104	57.11.4223	22 kOhm	2% 0.25W MF
R...105	57.11.4223	22 kOhm	2% 0.25W MF
R...106	57.11.4223	22 kOhm	2% 0.25W MF
R...107	57.11.3362	3.6 kOhm	1% 0.25W MF
R...108	57.11.5106	10 kOhm	0.25W MF
R...109	57.11.4823	82 kOhm	0.25W MF
R...110	57.11.4101	100 Ohm	0.25W MF
R...111	57.11.4223	22 kOhm	2% 0.25W MF
R...112	57.11.4104	100 kOhm	0.25W MF
R...113	57.11.4104	100 kOhm	0.25W MF
R...114	57.19.0100	10 Ohm	0.33W
R...115	57.11.4104	100 kOhm	0.25W MF
R...116	57.11.4104	100 kOhm	0.25W MF
R...117	57.11.4104	100 kOhm	0.25W MF
R...118	57.11.4391	390 Ohm	0.25W MF
R...119	57.11.4333	33 kOhm	0.25W MF
R...120	57.11.4822	8.2 kOhm	0.25W MF
R...121	57.11.4104	100 kOhm	0.25W MF
R...122	57.11.4104	100 kOhm	0.25W MF
R...123	57.11.5106	10 kOhm	0.25W MF
R...124	57.11.4103	10 kOhm	0.25W MF
R...125	57.11.5106	10 kOhm	0.25W MF
R...126	57.11.4333	33 kOhm	0.25W MF
R...127	57.11.4330	33 Ohm	0.25W MF
R...128	57.11.4333	33 kOhm	0.25W MF
R...129	57.11.5106	10 kOhm	0.25W MF
R...130	57.11.4333	33 kOhm	0.25W MF
R...131	57.11.3362	3.6 kOhm	1% 0.25W MF
R...132	57.11.3362	3.6 kOhm	1% 0.25W MF
R...133	57.11.3471	470 Ohm	1% 0.25W MF
R...134	57.11.3471	470 Ohm	1% 0.25W MF
R...135	57.11.3362	3.6 kOhm	1% 0.25W MF
R...136	57.11.3362	3.6 kOhm	1% 0.25W MF
R...137	5 kOhm	log fader	see note 3)
R...138	57.11.4334	330 kOhm	0.25W MF
R...139	57.11.4151	150 Ohm	0.25W MF
R...140	not exist		(replaced by 0104)
R...141	57.11.3272	2.7 kOhm	5% 0.25W MF
R...142	58.01.9501	500 Ohm	10% 0.5 W trimming resistor
R...143	57.11.4102	1 kOhm	0.25W MF
R...144	57.11.4333	33 kOhm	0.25W MF
R...145	57.11.4330	33 Ohm	0.25W MF
R...146	57.11.3512	5.1 kOhm	1% 0.25W MF
R...147	57.11.3512	5.1 kOhm	1% 0.25W MF
R...148	57.11.4330	33 Ohm	0.25W MF
R...149	57.11.3512	5.1 kOhm	1% 0.25W MF
R...150	57.11.3512	5.1 kOhm	1% 0.25W MF
R...151	57.11.3272	2.7 kOhm	5% 0.25W MF
R...152	58.01.9103	10 kOhm	10% 0.5 W trimming resistor
R...153	57.11.4182	1.8 kOhm	0.25W MF
R...154	57.11.4330	33 Ohm	0.25W MF
R...155	57.11.4223	22 kOhm	0.25W MF
R...156	57.11.3473	47 kOhm	5% 0.25W MF
R...157	57.11.3471	470 Ohm	5% 0.25W MF
R...158	57.11.3272	2.7 kOhm	5% 0.25W MF
R...159	57.11.3502	3 kOhm	1% 0.25W MF
R...160	57.11.4474	470 kOhm	2% 0.25W MF
R...161	57.11.3302	3 kOhm	1% 0.25W MF
R...162	57.11.3473	47 kOhm	1% 0.25W MF
R...163	57.11.3302	3 kOhm	1% 0.25W MF
R...164	57.11.3473	47 kOhm	1% 0.25W MF
R...165	57.11.3302	3 kOhm	1% 0.25W MF
R...166	57.11.3272	2.7 kOhm	1% 0.25W MF
R...167	57.11.3302	3 kOhm	1% 0.25W MF
R...168	57.11.3302	3 kOhm	1% 0.25W MF
R...169	57.11.4474	470 kOhm	2% 0.25W MF
R...170	57.11.3150	15 Ohm	1% 0.25W MF
R...171	57.11.3302	3 kOhm	1% 0.25W MF
R...172	57.11.3302	3 kOhm	1% 0.25W MF
R...173	57.11.3150	15 Ohm	1% 0.25W MF
R...174	57.11.3302	3 kOhm	1% 0.25W MF
R...175	57.11.3302	3 kOhm	1% 0.25W MF
R...176	57.11.3302	3 kOhm	1% 0.25W MF
R...177	57.11.3302	3 kOhm	1% 0.25W MF
R...178	57.11.3302	3 kOhm	1% 0.25W MF
R...179	57.11.3302	3 kOhm	1% 0.25W MF
R...180	57.11.3689	6.8 Ohm	1% 0.25W MF
R...181	57.11.3689	6.8 Ohm	1% 0.25W MF

Ad . POS.	REF.No.	DESCRIPTION	MANUFACTURER
A...101	1.911.199.00	connecting cable 1	St
C...100	59.22.2221	220 uF -20% 6V EL	
C...101	59.22.2221	220 uF -20% 6V EL	
C...102	not used		
C...103	not used		
C...104	not used		
C...105	59.34.4221	220 pF 5% CE	
C...106	59.26.0470	47 uF 20% 6V SAL	
C...107	59.06.0102	1 nF 10% 50V PE	
C...108	59.26.0680	68 uF 20% 6V SAL	
C...109	59.06.0682	6.8 nF 50V PE	
C...110	59.26.0680	68 uF 20% 6V SAL	
C...111	59.26.0680	68 uF 20% 6V SAL	
C...112	59.26.0680	68 uF 20% 6V SAL	
C...113	59.26.0680	68 uF 20% 6V SAL	
C...114	59.34.4221	220 pF 5% CE	
C...115	not used		
C...116	59.26.0680	68 uF 20% 6V SAL	
C...117	59.26.0680	68 uF 20% 6V SAL	
C...118	59.26.0680	68 uF 20% 6V SAL	
C...119	59.34.7151	150 pF 2% CE	
C...120	59.34.7151	150 pF 2% CE	
C...121	59.26.0680	68 uF 20% 6V SAL	
C...122	59.34.4101	100 pF 5% CE	
C...123	59.26.0680	68 uF 20% 6V SAL	
C...124	59.26.0680	68 uF 20% 6V SAL	
C...125	59.22.2221	220 uF -20% 6V EL	
C...126	59.22.2221	220 uF -20% 6V EL	
C...127	59.06.1681	680 pF 1% 500V PP	
C...128	59.06.1681	680 pF 1% 500V PP	
C...129	not used		
C...130	not used		

Ad . POS.	REF.No.	DESCRIPTION	MANUFACTURER
C...131	not used		
C...132	not used		
C...133	not used		
C...134	59.26.0680	68 uF 20% 6V SAL	
C...135	59.06.0223	22 nF 50V PE	
C...136	59.22.6470	47 uF -20% 30V EL	
C...137	59.05.1102	1 nF 1% 500V PP	
C...138	59.05.1102	1 nF 1% 500V PP	
C...139	59.06.0333	33 nF 50V PE	
C...140	59.22.2221	220 uF -20% 6V EL	
C...141	59.22.6470	47 uF -20% 30V EL	
C...142	not used		
C...143	not used		
C...144	59.05.1681	680 pF 1% 500V PP	
C...145	59.05.1681	680 pF 1% 500V PP	
C...146	59.26.0680	68 uF 20% 6V SAL	
C...147	59.26.0680	68 uF 20% 6V SAL	
C...148	59.34.4101	100 pF 5% CER	
C...149	59.34.4101	100 pF 5% CER	
C...150	59.22.2221	220 uF -20% 6V EL	
C...151	59.06.0223	22 nF 50V PE	
C...152	59.06.0223	22 nF 50V PE	
C...153	59.06.0333	33 nF 50V PE	
C...154	59.06.0333	33 nF 50V PE	
C...155	59.22.5101	100 uF -20% 16V EL	
C...156	59.22.5101	100 uF -20% 16V EL	
C...157	59.06.0682	6.8 nF 50V PE	
C...158	59.06.0682	6.8 nF 50V PE	
C...159	not used		
C...160	not used		

Ad . POS.	REF.No.	DESCRIPTION	MANUFACTURER
C...164	59.34.2220	22 pF CE	
C...165	59.34.4660	68 pF CE	
C...166	not used		
C...167	59.34.2330	33 pF CE	
D...100	50.04.0125	1M4448	any
D...101	50.04.0125	1M4448	any
D...102	50.04.0105	1M4004	1A
D...103	50.04.0105	1M4004	1A
D...104	50.04.0125	1M4448	any
DL...100	Q0Y41N	LED red	see note 3)
IC...100	50.10.0106	TL 431 voltage regulator	Ti
IC...101	50.09.0101	TL 072 dual fet - op. amp.	Ti
IC...102	50.07.0027	GM4027 dual JK-FF	CMOS Met,Fc
IC...103	50.09.0105	NESS32 N dual op. amp.	Ti,Sig,Ra
IC...104	50.05.0244	NESS34AN single op. amp. low noise	Ti,Sig,Ra
IC...105	50.09.0105	NESS32 N dual op. amp.	Ti,Sig,Ra
IC...106	50.09.0105	NESS32 N dual op. amp.	Ti,Sig,Ra
IC...107	50.09.0105	NESS32 N dual op. amp.	Ti,Sig,Ra
IC...108	50.09.0118	RC4562MB dual op. amp.	Ra
IC...109	50.09.0117	MC33076 dual op. amp.	Met
K...101	not used	option 1 see note 1)	
P...101	54.01.0359	2*16pin euroconnector	Bu
Q...100	50.03.0665	BC 327 PNP IC max 800mA	match Sie
Q...101	50.03.0516	BC 337 NPN IC max 800mA	match Sie
Q...102	50.03.0515	BC 307 PNP B > 100 (BC 557 , BC 560)	any
Q...103	50.03.0436	BC 237 NPN B > 100 (BC 547 , BC 550)	any

MASTER UNIT MKII

Master Board CH2 1.911.324

Ad .POS. .REF.No. .DESCRIPTION. .MANUFACTURER

R...381	57.11.3689	6.3 Ohm	1%	0.25W	MF
R...382					not exist
R...383	57.11.4223	22 Ohm		0.25W	MF
R...384	57.11.4332	3.3 kOhm		0.25W	MF
R...385	57.11.4332	3.3 kOhm		0.25W	MF
R...386	57.11.4103	10 kOhm		0.25W	MF
R...387	57.11.4339	3.3 Ohm		0.25W	MF
R...388	57.11.4339	3.3 Ohm		0.25W	MF
R...389	57.11.4103	10 kOhm		0.25W	MF
R...390	57.11.4821	820 Ohm		0.25W	MF
R...391	57.11.4102	1 kOhm		0.25W	MF
R...392	57.11.4333	33 kOhm		0.25W	MF
R...393					not used
R...394	57.11.4103	10 kOhm		0.25W	MF
R...395	57.11.4339	3.3 Ohm		0.25W	MF
R...396	57.11.4339	3.3 Ohm		0.25W	MF
R...397	57.11.4103	10 kOhm		0.25W	MF
R...398	57.11.3152	1.5 kOhm	1%	0.25W	MF
R...399	57.11.3152	1.5 kOhm	1%	0.25W	MF
R...400	57.11.3392	3.3 kOhm	1%	0.25W	MF
R...401	57.11.3392	3.3 kOhm	1%	0.25W	MF
R...402	57.11.3272	2.7 kOhm	1%	0.25W	MF
R...403	57.11.3272	2.7 kOhm	1%	0.25W	MF
R...404	57.11.4330	33 Ohm		0.25W	MF
R...405	57.11.4223	22 kOhm		0.25W	MF
R...406	57.11.4391	390 Ohm		0.25W	MF
R...407	57.11.3471	470 Ohm	5%	0.25W	MF
R...408	57.92.1271	6.5 Ohm			PTC
R...409	57.92.1271	6.5 Ohm			PTC
R...410					not used
R...411	57.11.4333	33 kOhm		0.25W	MF
R...412	57.11.4104	100 kOhm		0.25W	MF
R...413	57.11.4330	33 Ohm		0.25W	MF
R...414	57.11.4104	100 kOhm		0.25W	MF
R...415					not used
R...416	57.11.4104	100 kOhm		0.25W	MF
R...417	57.19.0330	33 Ohm	0.33W		fusible resistor
R...418	57.19.0330	33 Ohm	0.33W		fusible resistor
S...300		1 * U			see note 3)
S...301					fader-end switch combined with R337
S...302		OH-OH			see note 5)
S...303		OH-OH			see note 5)
T...301	1.022.362.00			output trafo 1 : 1.45	St
W...300					not used
W...301	57.11.4000			10mm link	
W...302	1.010.321.64			5mm link	
W...303				option 3/4	see note 1)
W...304	57.11.4000			10mm link	
W...305					not used

- 1) --> see optionlist 1.911.325.00
- 2) --> Wornumber see Poslst. - 1.911.315.xx
- 3) --> Wornumber see Poslst. - 1.911.315.xx
- 1.911.325.xx
- 1.911.335.xx
- 4) --> Wornumber see Poslst. - 1.911.325.xx
- 1.911.335.xx
- 5) --> Wornumber see Poslst. - 1.911.335.xx

History :
 29.11.90 (01) - IC 308 -> M33078
 - C 367 -> 32pF
 11.12.90 (02) - C 306 -> SAL-Bauform (Platzgruende)
 4.12.91 (03) R339 is replaced by D304

CE=Ceramic, CF=Carbon Film, EL=Electrolytic, MF=Metal Film,
 PE=Polyester, SAL=Solid Aluminum

MANUFACTURER: Bu=Burndy, ITT=Intermetall, Mot=Motorola, NS=National
 Semiconductors, Six=Siliconix, St=Studer
 Sie=Siemens, Fc=Fairchild, Sig=Signetics
 GI=General Instruments, Ra=Raytheon
 TI=Texas Instrument

1.911.324.00	MASTER BOARD CH 2	TA 88/02/2400
1.911.324.00	MASTER BOARD CH 2	TA 90/11/2901
1.911.324.00	MASTER BOARD CH 2	TA 90/12/1102
1.911.324.00	MASTER BOARD CH 2	HOR91/12/0403

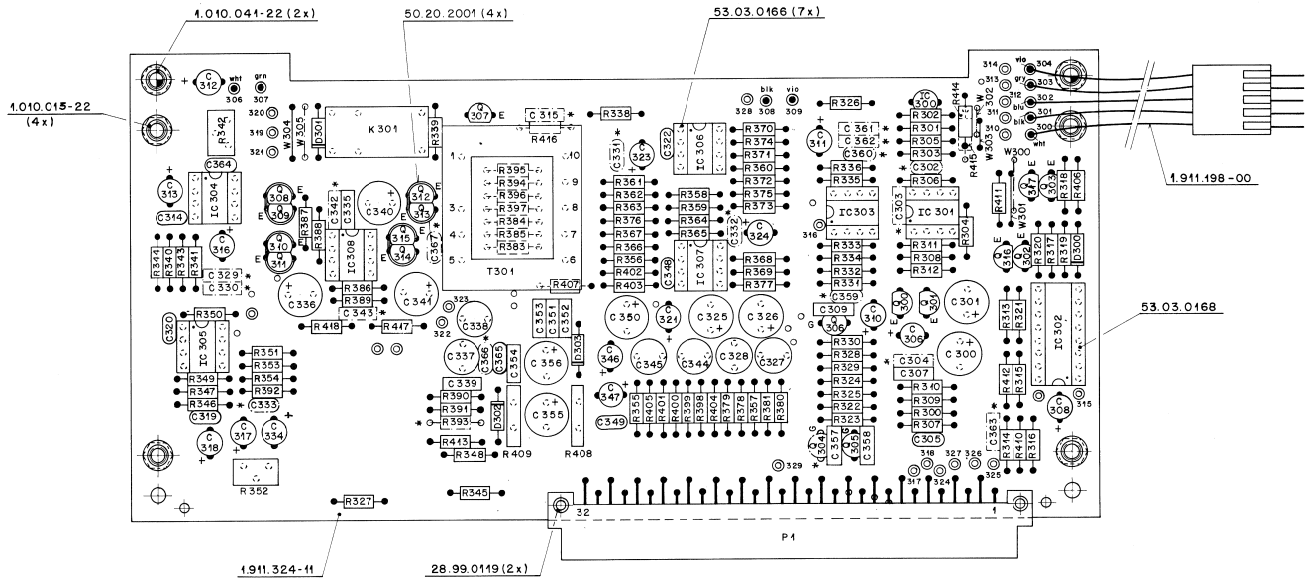

* NOT USED

Schilder 1.911.324-04 / 43.01.0108
 aufgeklebt nach Fabrikationsmuster.

VCA FLACHBAHNREGLER

Der VCA Flachbahnregler 1.911.210 dient zur Regelung eines monophonen Tonsignals, wobei vier verschiedene Steuergrößen auf das Steuerglied (den spannungsgesteuerten Verstärker VCA) einwirken.

- Flachbahnregler
- Limiter/Kompressor
- externe Steuerung durch Gruppenregler
- externe Steuerung durch Rechner

BEDIENUNGSELEMENTE

LIMITER/KOMPRESSOR TEIL

- GRM** (gain reduction meter)
LED zeigen die Größe der Abschwächung (rot) resp. Anhebung (grün) an.
- RELEASE** Einstellung der Rücklaufzeit des Limiter/Kompressors (min. 50 ms max. 2...10 s). Die Rücklaufzeit ist nicht nur von der Potentiometerstellung sondern auch vom Programminhalt abhängig dh. kurze Uebersteuerungen ergeben kürzere Rücklaufzeiten als lange andauernde Ueberschreitung der Kompressionsschwelle.
- RATIO** Verhältnis der Dynamikkompression einstellbar von 2:1 ... 20:1. Um einen gleichbleibenden Lautstärkeindruck zu erzielen wird mit zunehmendem Ratio die Grundverstärkung angehoben.
- COMPR IN** Limiter/Kompressor wird eingeschaltet.
- LINK** Kopplung der Steuerspannung mit dem rechts benachbarten VCA Regler (Stereopaar). Die LED zeigt, dass der benachbarte Regler zugeschaltet ist. Die LED signalisiert den letzten angekoppelten Regler einer Gruppe.

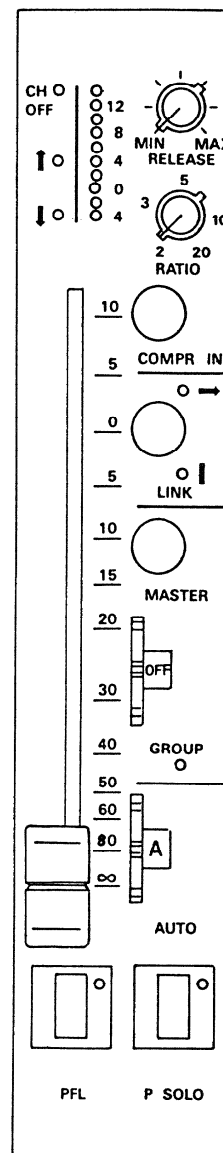

GROUP VCA GRUPPEN-TEIL

Mit dem Daumenradschalter kann eine von 10 Gruppenschienen angewählt werden. Eine der aufgeschalteten VCA Einheiten wird mit der Taste MASTER zum Gruppenregler erhoben. Er bestimmt nun als Gruppenregler die Verstärkung aller Gruppenmitglieder. Zur Bestätigung leuchtet die Group-LED bei allen Gruppenmitgliedern auf.

V C A FADER

The VCA fader 1.911.210 is used to control a monophonic audio signal. Four different control variables act on the controlling element of the voltage-controlled amplifier (VCA).

- Fader
- Limiter/compressor
- External control by group fader
- External control by computer

OPERATING CONTROLS

LIMITER/COMPRESSOR SECTION

- GRM (gain reduction meter)
LEDs indicate the amount of gain reduction (red) or boost (green) respectively.
- RELEASE Adjustment of the limiter / compressor's release time (min. 50 ms, max. 2 to 10 s). The release time depends not only on the potentiometer setting, but also on the program content, i.e. short overdriving results in shorter release times than if the compression threshold is continuously exceeded.
- RATIO Ratio of the dynamic range compression, adjustable from 2:1 to 20:1. In order to achieve a uniform loudness impression, the basic gain is boosted with higher ratios.
- COMPR IN Limiter/compressor is switched on.
- LINK Coupling of the control voltage with the right-hand adjacent VCA fader (stereo pair). The LED indicates that the adjacent fader is switched into the circuit. The LED signals the last coupled fader of a group.

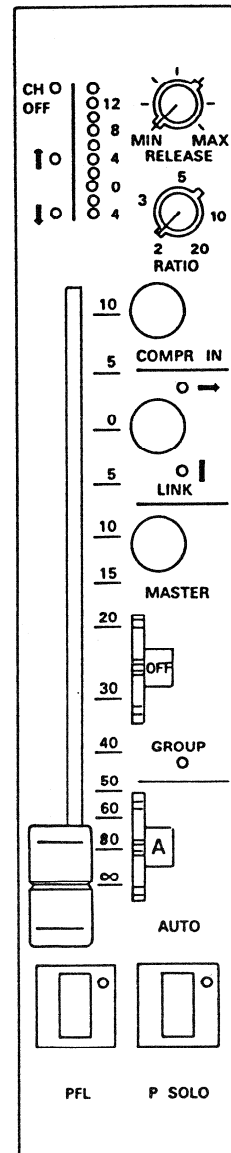

GROUP VCA GROUP SECTION

One of 10 group buses can be selected with the thumb wheel switch. One of the connected VCA units is designated as the group fader by pressing the MASTER key. This group fader now determines the gain of all group members. The group LED of all group members turns on to acknowledge this status.

AUTOMATIKTEIL

Anzeige-LED \updownarrow dient zur Anpassung der Reglerstellung an die vom Rechner angebotene Steuerspannung.

- AUTO Daumenradschalter bestimmt den Zustand des VCA-Reglers gegenüber dem Rechner.
- A+B Zustand wird durch den VCA Mode Selector bestimmt.
- R READ übernimmt die absolute Reglerstellung vom Rechner.
- W WRITE übergibt die absolute Reglerstellung dem Rechner.
- U UPDATE korrigiert Reglerstellung im Rechner (relativ zur Stellung 0 dB).
- M MANUAL nur Flachbahnregler im Betrieb

ABHOERTEIL

- PFL Abhören des Audiosignals vor Regler
- P.SOLO Kontrolle des Audiosignals nach Regler und nach Panoramapotiometer.

TECHNISCHE DATEN

EINGANG

- unsymmetrisch, Eingangswiderstand
- max. Eingangsspegel (d=1%, f=1kHz) Verstärkung (Begrenzer aus)

AUSGANG

- unsymmetrisch, Ausgangswiderstand
- max. Ausgangsspegel (d=1%, f=1kHz) (d=1%, f=1kHz) + 21 dBu

FREMDSPANNUNGSABSTAND (bez. auf 0dBu)

- in Reglerstellung +10dB
- in Reglerstellung 0dB
- in Reglerstellung -00dB

KOMPRESSOR / BEGRENZER

- Einsatzpunkt
- Kompressionsverhältnis

- Ansprechzeit
- Rücklaufzeit

SIGNALWEG (bezogen auf 0dBu)

- Frequenzgang (@ 0.5 dB)
- max. Reglerdämpfung (@ 16 kHz)
- Klirrfaktor (@ 30Hz...16kHz)

STROMVERBRAUCH

- +/- 15 V, 90 mA
- 6 V, 90 mA
- 24 V, 1.5 mA

ANSCHLUSS ZUM RECHNER

- Sendeweg
- unsymmetrisch, Impedanz
- Ausgangsspannung

Empfangsweg

- unsymmetrisch, Impedanz
- Eingangsspannung

- Logiksignal write tief
- hoch

AUTOMATIC SECTION

Indicating LED \updownarrow For matching the fader setting to the control voltage offered by the computer.

- AUTO Thumb wheel switch, determines the status of the VCA fader relative to the computer.
- A+B Status is determined by the VCA mode selector.
- R READ accepts the absolute fader setting from the computer.
- W WRITE transfers the absolute fader setting to the computer.
- U UPDATE to correct the fader setting in the computer (relative to the 0dB position).
- M MANUAL, only the fader is active.

MONITORING SECTION

- PFL Prefader listening of the audio signal.
- P.SOLO To check the audio signal after the fader and after the panorama potentiometer.

SPECIFICATIONS

INPUT

- unbalanced, impedance > 50 kohms
- max. level (d=1%, 1kHz) + 21 dBu
- overall gain (limiter off) + 10...-100dB

OUTPUT

- unbalanced, impedance < 50 Ohms
- max. level

S/N RATIO (DIN 45405)

- Fader position +10dB - 96 dB
- Fader position 0dB -103 dB
- Fader position -00dB -110 dB

KOMPRESSOR / LIMITER

- threshold level - 15 dBu...+ 5 dBu
- Ratio (see diagram) 2:1 ... 20:1
- gradual entry into desired compression (soft knee)
- attack time 1 ms
- release time 50 ms ... 2 s
- program dependent

SIGNAL PATH (@ 0dBu)

- frequency response (@ .5dB) 20 Hz ... 100 kHz
- max. attenuation (@ 16 kHz) 103 dB
- distortion (@ 30Hz ...16kHz) < .03%

POWER REQUIREMENTS

- +/- 15 V, 90 mA
- 6 V, 90 mA
- 24 V, 1.5 mA

AUTOMATION CONNECTIONS

- Send
- unbalanced, impedance < 50 ohms
- output voltage 0V ... +5.5V or -5.5V ... +5V
- selectable with jumper
- Return
- unbalanced, impedance > 5 kohms
- input voltage 0V ... +5.5V or -5.5V ... +5V
- selectable with jumper
- write low switched to GND
- high open collector

BLOCKSCHALTBILD

BLOCK DIAGRAM

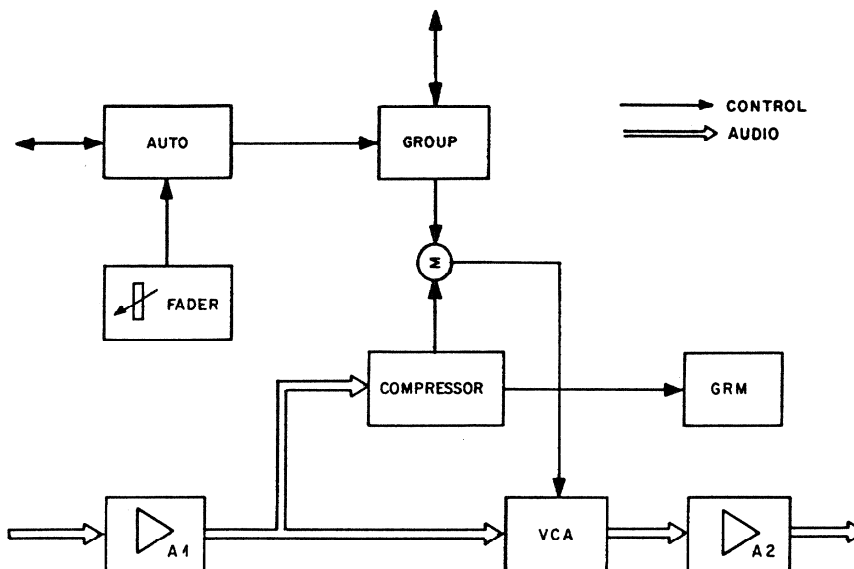

FUNKTIONSBESCHREIBUNG

Über den Eingangsverstärker A1 gelangt das Audiosignal auf den VCA und den Kompressor / Limiter. Nach dem VCA wird es über Verstärker A2 wieder ausgekoppelt. Die Steuergleichspannung wird dem VCA als Summe der Regelspannung des Kompressor/Limiters und der Steuerspannung des Flachbahnreglers zusammen mit den Steuerspannungen des Rechners und der Gruppensammelschiene zugeführt. Das GRM (Gain Reduction Meter) zeigt die Verstärkungsreduktion bei eingeschaltetem Limiter-Kompressor an.

AUTO - Block

Je nach Einstellung des Betriebsmodus-Schalters wird die vom Flachbahnregler abgegebene Steuerspannung verschiedenen Zielen zugeschaltet. Der Betriebsmodus-Schalter kann folgende sechs Stellungen einnehmen:

- A : Wahl des Master Status Moduls A
- B : Wahl des Master Status Moduls B
- R : READ Steuerung des VCA durch den Rechner
- W : WRITE Übernahme der Faderstellung auf den Rechner und gleichzeitige Steuerung des VCA
- U : UPDATE Korrektur der vom Rechner angelieferten Steuerspannung, wobei jede Abweichung von der Faderstellung 0dB als Korrekturfaktor eingelesen wird.
- M : MANUAL Steuerung des VCA durch den Flachbahnregler ohne Rechnerbeeinflussung.

Die Wahl der vier Zustände (R,W,U,M) durch die beiden übergeordneten Signale A + B erfordert eine zweipolige Steuerleitung. Die nachfolgenden Abbildungen zeigen den Verlauf der analogen Steuerspannungen und der beiden logischen Steuerbefehle.

FUNCTIONAL DESCRIPTION

The audio signal arriving from the input amplifier A1 is taken to the VCA and the compressor / limiter. After the VCA the audio signal is decoupled via amplifier A2. The DC control voltage is taken to the VCA as the sum of the compressor / limiter control voltage and the control voltage of the fader, together with the control voltages of the computer and of the group bus. The GRM (gain reduction meter) indicates the amount of gain reduction when the limiter/compressor is switched on.

AUTO - Block

Depending on the setting of the mode switch, the control voltage supplied by the fader is connected to various targets. The mode switch features six settings:

- A: Selects master status module A
- B: Selects master status module B
- R: READ Control of VCA via the computer
- W: WRITE Transfer of the fader setting to the computer with simultaneous control of the VCA.
- U: UPDATE Correction of the control voltage supplied by the computer; any deviation from the 0dB fader setting is entered as a correction factor.
- M: MANUAL Control of the VCA gain by the fader without computer influence.

A 2-conductor control line is required for selecting the four states (R, W, U, M) with the aid of the two bus assignment signals A+B. The following diagrams illustrate the routing of the analog control voltage and the two logical control commands.

MANUAL

R : L
W : L

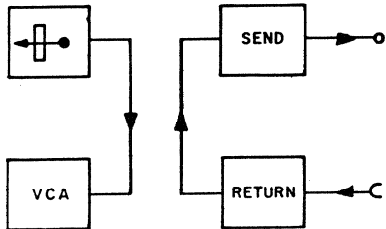

WRITE

R : L
W : H

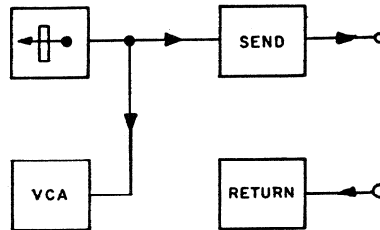

READ

R : H
W : L

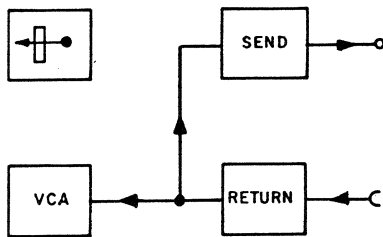

UPDATE

R : H
W : H

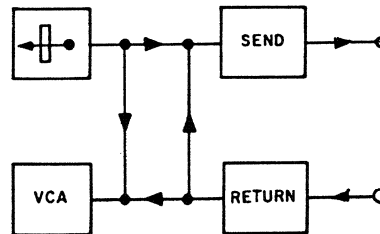

Die logischen Steuerbefehle R und W steuern die vier FET-Analogschalter wie folgt:

The logical control commands R and W control the four analog FET switches as follows:

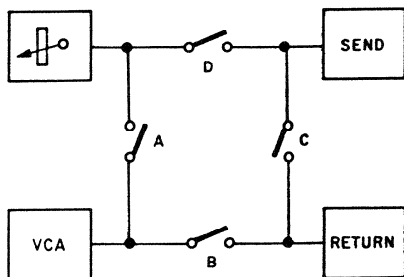

R	W	A	B	C	D
1	1	1	0	1	0
1	0	1	0	0	1
0	1	0	1	1	0
0	0	1	1	1	1

Die Umsetzung der Steuerbefehle wird wie folgt realisiert:

The control commands are translated as follows:

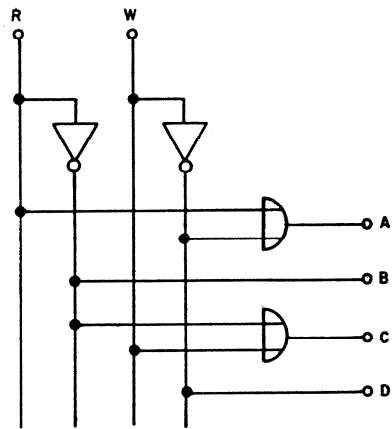

Das ergibt die folgende diskret aufgebaute Schaltung:

This results in the following discrete circuit:

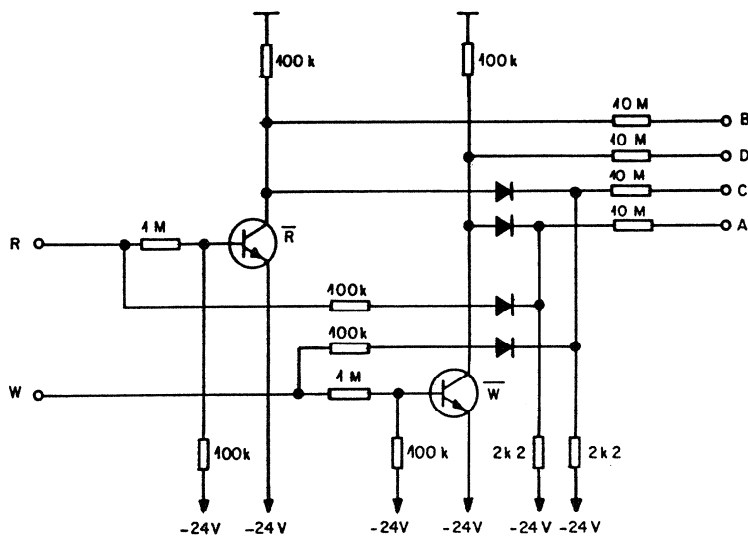

Der analoge Teil der Schaltung ist nach folgendem Schema aufgebaut:

The analog section of the circuit is implemented according to the following diagram:

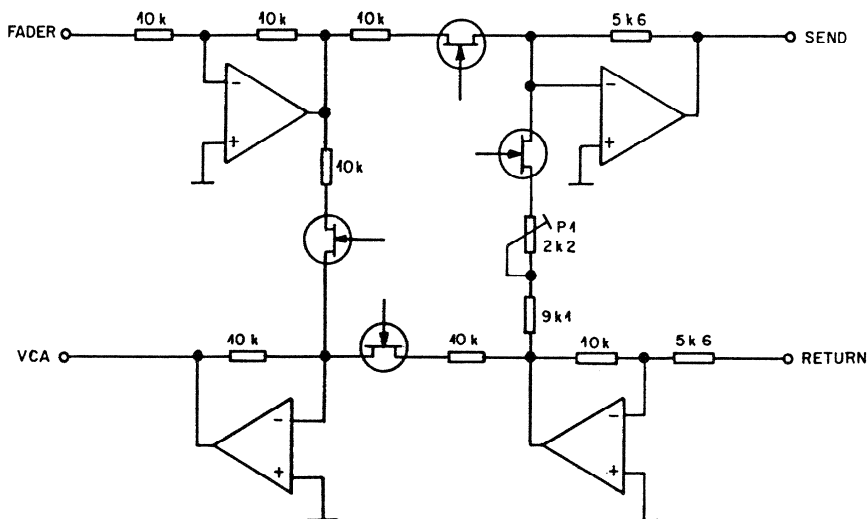

Der Trimmer P1 wird in Betriebsart MANUAL so eingestellt, dass die READ-Spannung der SEND-Spannung entspricht. Dadurch wird sichergestellt, dass der Rechner im READ und im unkorrigierten (Faderstellung 0dB) UPDATE Modus die RETURN Spannung unverändert zurückerhält. Spannungsdifferenzen würden ja bei jedem Durchgang eine erneute Verstärkungsdrift bewirken.

Die nächste Abbildung zeigt die vollständige Automatikschaltung. Der Differenzverstärker zeigt an den beiden LEDs, ob die Fader-Spannung gleich, grösser oder kleiner als die vom Rechner kommende Spannung ist. Um einen Lautstärkesprung beim Umschalten von READ auf WRITE resp. von UPDATE auf MANUAL zu vermeiden, müssen beide LED erloschen sein.

The trimmer P1 is set in the MANUAL mode in such a way that the READ voltage corresponds to the SEND voltage. This ensures that the computer receives the RETURN voltage without change in READ mode and in the uncorrected (fader setting 0dB) UPDATE mode because any voltage differences would cause a new gain drift in every passage.

The following diagram illustrates the complete automatic circuit. The differential amplifier indicates on both LEDs whether or not the fader voltage is the same, larger or smaller than the voltage arriving from the computer. To avoid a loudness jump when switching from READ to WRITE or from UPDATE to MANUAL, both LEDs must be off.

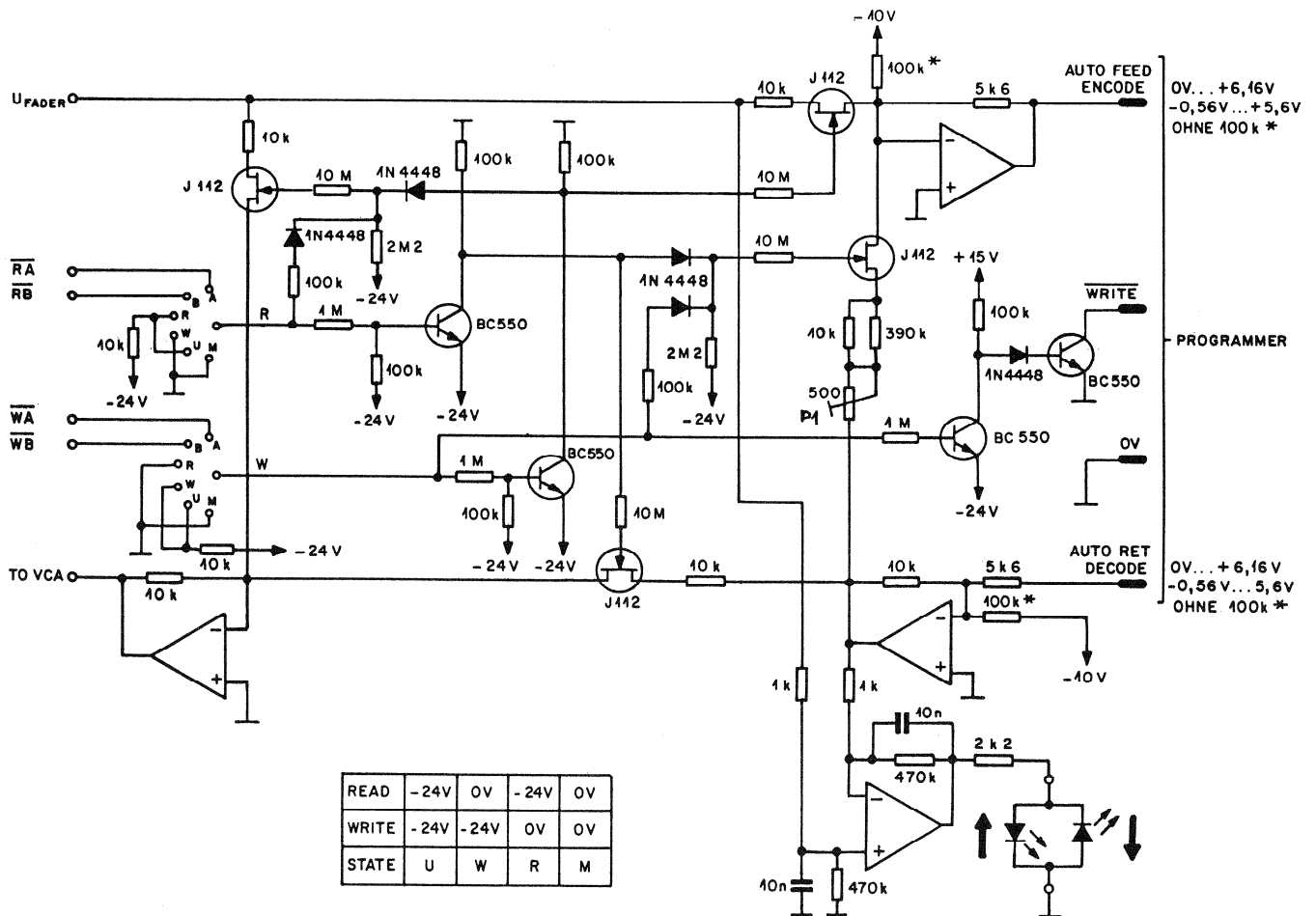

FLACHBAHNREGLER

Die Einheit ist mit einem linearen Flachbahnregler ausgerüstet. Die Regelcharakteristik des VCAs ist dB-linear zur angelegten Steuerspannung. Um den gewünschten, weder Spannungs- noch dB-linearen Reglerverlauf zu erhalten, muss ein Funktionsgenerator mit dem Verlauf

$$y = \operatorname{artanh} x$$

zwischen Fader und VCA geschaltet werden. Dies wird mit der folgenden Schaltung erreicht:

FADER

The module is equipped with a fader of linear taper. The control characteristic of the VCA is dB-linear to the applied control voltage. In order to achieve the desired fader behavior, that is neither voltage-linear nor dB-linear, a function generator with the characteristic

$$y = \operatorname{artanh} x$$

must be connected between the fader and the VCA. This is accomplished with the following circuit:

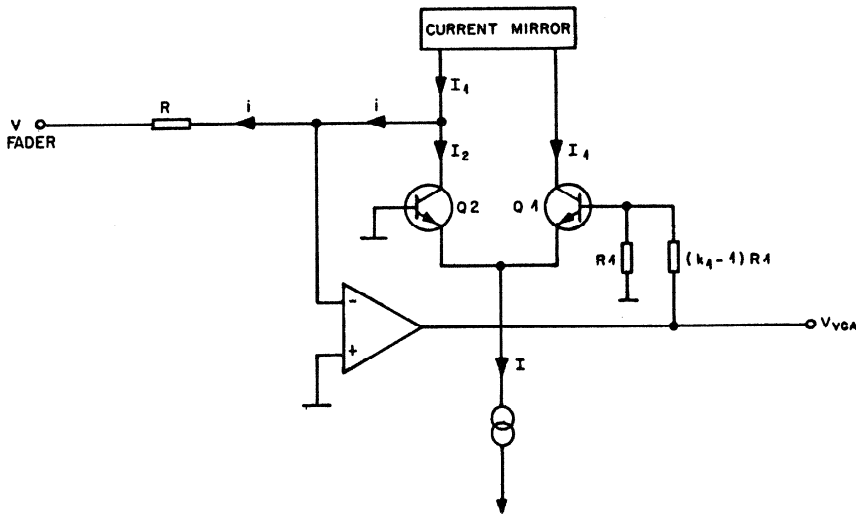

Mit dem Trimmer SCALA OFFSET lässt sich eine mechanische Abweichung des Faders zur Skala ausgleichen.

With the SCALE OFFSET trimmer it is possible to compensate for any mechanical deviation of the fader relative to the scale.

Schaltung des Funktions-Generators

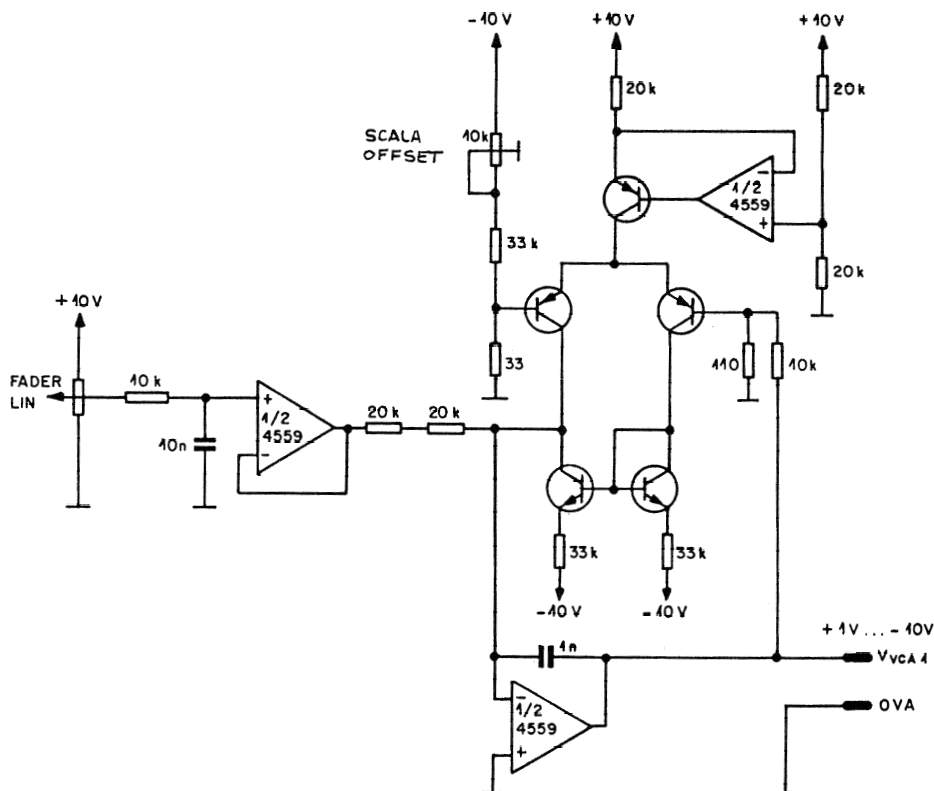

GRUPPENBILDUNG (GROUPING)

GROUPING

Blockdiagram Grouping

Grouping block diagram

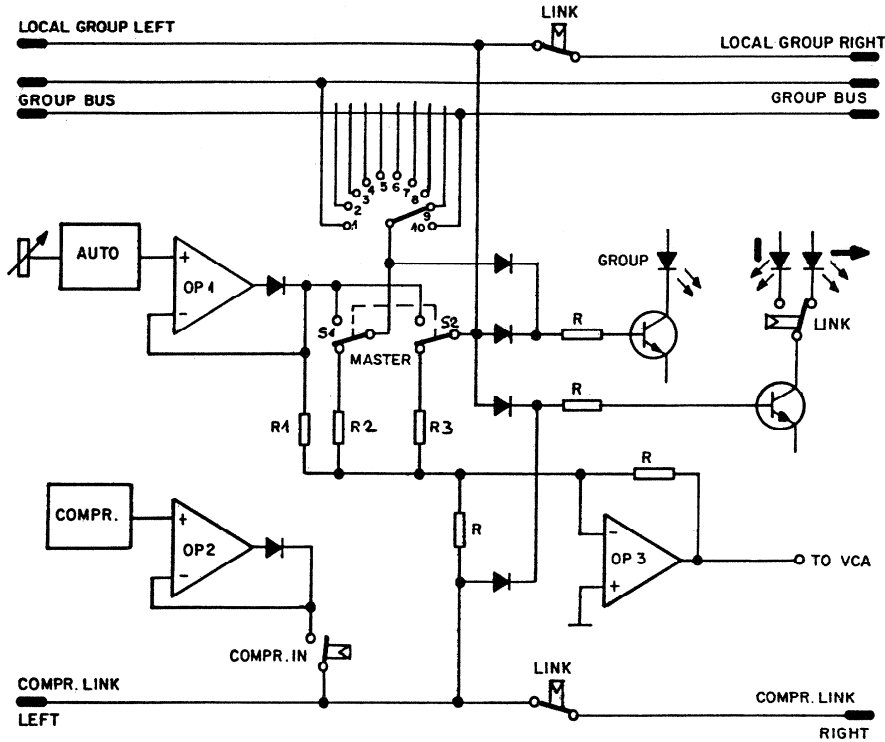

Das vom Flachbahnregler abgegebene Steuersignal gelangt direkt über R1 auf den Addierer OP3, welcher den VCA steuert. Bei unbetätigtem MASTER-Schalter S1 gelangt die über den GROUP-Selector angewählte Steuerspannung zusätzlich auf den Addierer. Auch das vom LOCAL GROUP BUS stammende Signal wird an OP3 aufsummiert. Sobald der MASTER-Schalter betätigt wird, gelangt die eigene Faderspannung auf den angewählten Buss und übernimmt damit die Kontrolle über alle auf diesen Bus geschalteten Kanäle. Gleichzeitig wird die Faderspannung auch dem LOCAL GROUP BUS zugeführt und so der benachbarte, "gelinkte" Kanal beeinflusst.

The control signal supplied by the linear fader is taken directly via R1 to the adder OP3 which controls the VCA. When the MASTER switch S1 is not actuated, the control voltage chosen via the GROUP selector is applied to the adder. Also, the signal originating from the LOCAL BUS is added to OP3. As soon as the MASTER switch is actuated, the own fader voltage reaches the selected bus and thereby controls all channels connected to this bus. The fader voltage is also taken to the LOCAL GROUP BUS which means that the adjacent, "linked" channel is influenced.

KOMPRESSOR / LIMITER

Der VCA-FADER ist mit einem vorwärts-gesteuerten Kompressor / Limiter ausgerüstet. Die Regelspannung des VCA wird also vom Audiosignal abgeleitet, das vor dem Regelglied anliegt. Das Kompressionsverhältnis ist im Bereich 2:1 bis 20:1 einstellbar und die Rücklaufzeit kann ebenfalls in einem weiten Bereich gewählt werden. Diese ist aber nicht nur von der Potentiometereinstellung, sondern auch vom angebotenen Programm selber abhängig. Um einen konstanten Lautstärkeindruck bei zunehmendem Kompressions-Ratio zu erzielen wird die Grundverstärkung angehoben (max. 6dB bei einem Ratio von 20:1). Die statische Übertragungskennlinie weist einen weichen Übergang zwischen linearem und komprimiertem Bereich auf, um die dynamischen Regelverzerrungen zu verkleinern und die Regelvorgänge weitgehend unhörbar zu machen.

COMPRESSOR / LIMITER

The VCA FADER is equipped with a forward-controlled compressor / limiter. The control voltage of the VCA is consequently derived from the audio signal that is available at the input to the control element. The compression ratio is adjustable from 2:1 to 20:1 and the release time can also be selected over a wide range. This depends not only on the potentiometer setting, but also on the offered program itself. In order to achieve a uniform loudness sensation for increasing compression ratios, it is necessary to increase the basic gain (max. 6dB for a ratio of 20:1). The static transmission curve features a soft transition between the linear and the compressed zone in order to minimize dynamic control distortions and to render the control operation as inaudible as possible.

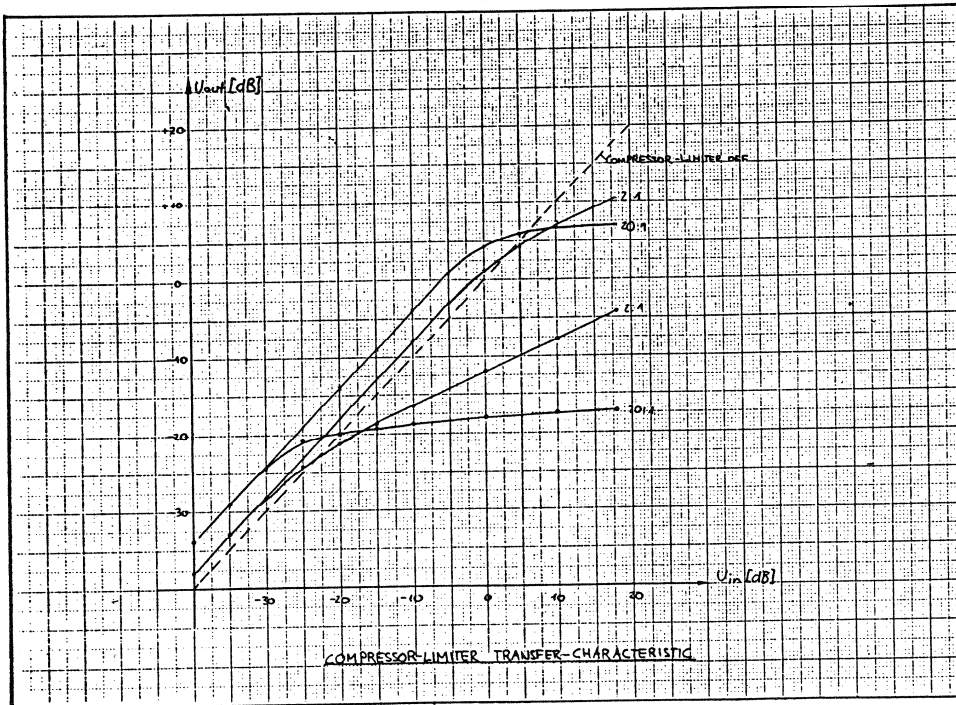

Logarithmierer / Rücklaufzeit

Für die Ausgangsspannung des unten abgebildeten Logarithmierers gilt

$$U_{out} = k * U_t \ln\left(\frac{U_{in}}{U_{ref}}\right)$$

Logarithmation section / release time

The following applies to the output voltage of the logarithmation section illustrated below:

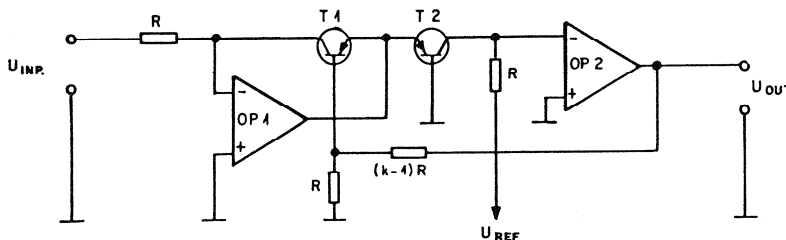

Fügen wir in die Rückkopplung des Logarithmierers einen Spitzengleichrichter mit Zeitkonstante, so folgt die Ausgangsspannung dem Logarithmus des Eingangsspitzenwertes. Ein aktiver Gleichrichter sorgt dafür, dass nur negative Eingangsspannungen entstehen können. Die nächste Abbildung zeigt den erweiterten Logarithmierer, dessen Ausgangsspannung bei höheren Frequenzen der Formel

$$U_{out} = k * U_t \ln \left(\frac{|U_{INP}|}{U_{REF}} \right)$$

folgt.

Durch anlegen einer Spannung an die Basis von T2 kann die Ansprechschwelle der Schaltung verändert werden.

By inserting a peak rectifier with a time constant into the feedback of the logarithmation section, the output voltage follows the logarithm of the input peak value. An active rectifier ensures that only negative input voltages can occur. The next diagram illustrates the expanded logarithmation section whose output voltage, in the case of higher frequencies, follows the formula

$$U_{out} = k * U_t \ln \left(\frac{|U_{INP}|}{U_{REF}} \right)$$

The threshold of this circuit can be changed by applying a voltage to the base of T2.

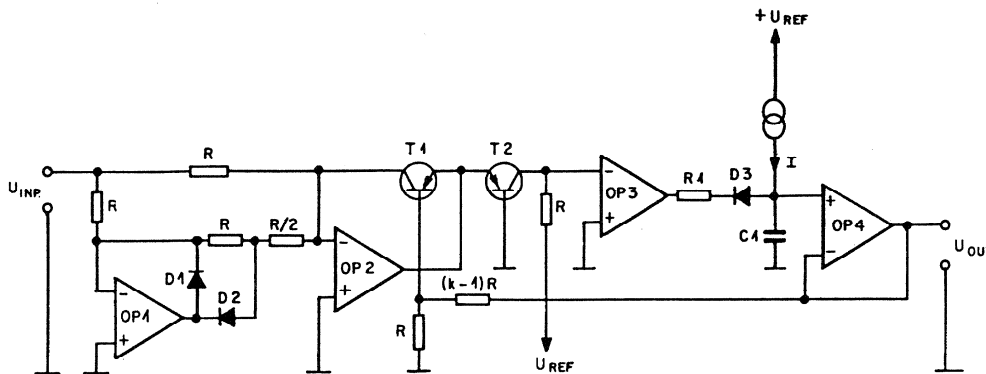

Die Ausgangsspannung gehorcht der Eingangsspannung nach der Funktion des Logarithmierers, verzögert durch die Ansprechzeitkonstante $T_1 = R_1 * C_1$. Wird die Eingangsspannung reduziert, entlädt sich C_1 mit I solange bis die log. Funktion wieder erfüllt ist (Rücklaufzeitkonstante). Wird die Stromquelle I variabel gemacht, kann die Rücklaufzeit in weiten Grenzen eingestellt werden. Durch Zuschaltung der Zeitkonstanten $R_2 * C_2$ und $R_3 * C_3$ und gleichzeitiger Beeinflussung der Stromquelle I durch die Ausgangsspannung wird die Rücklaufzeit dem Programminhalt angepasst. Diese programmabhängige Rücklaufzeit ergibt, besonders beim Anlegen von impulsförmigen hohen Eingangssignalen, einen wesentlich verbesserten Höreindruck.

The output voltage follows the input voltage according to the function of the logarithmation section, delayed by the response time constant $T_1 = R_1 * C_1$. If the input voltage is lowered, C_1 discharges with I until the log. function is again satisfied (release time constant). If the current source is made variable, the release time constant can be adjusted over a wide range. The release time is adjusted to the program content by adding the time constants $R_2 * C_2$ and $R_3 * C_3$ while simultaneously influencing the current source I . This program-dependent release time results in a much improved aural performance, particularly when pulse-shaped input signals of high level are occurring.

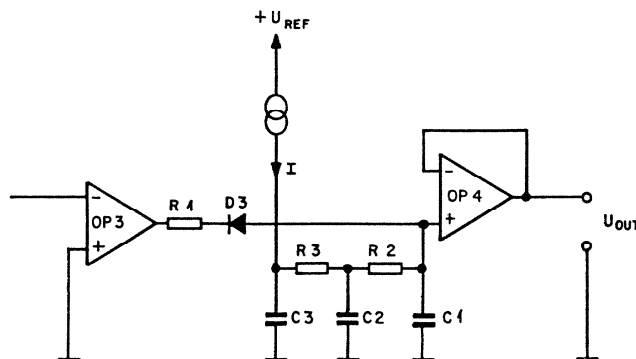

Rücklaufzeiten nach verschiedenartiger Uebersteuerung:

Release times resulting from different types of overmodulation:

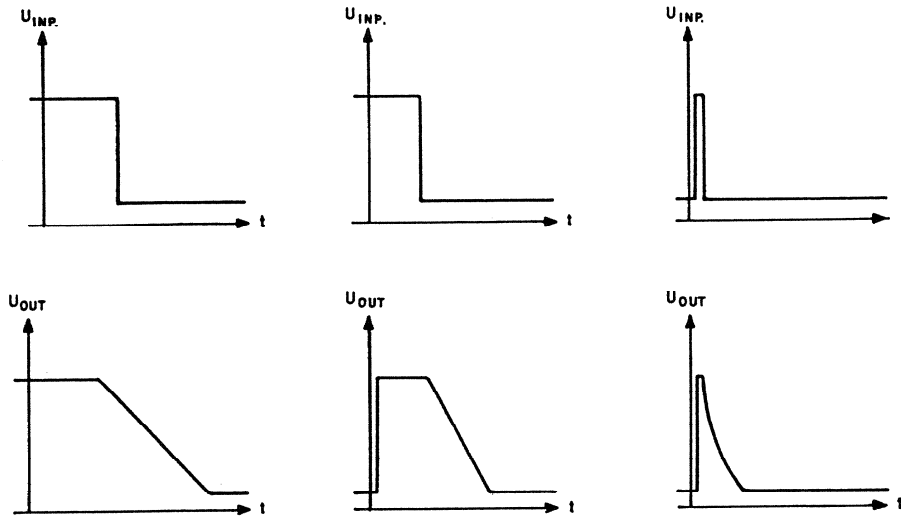

Eine tieffrequente Eingangsspannung erzeugt bei kurzer Rücklaufzeit eine Steuerspannung mit überlagerter Niederfrequenz (Rippel). Dies bewirkt eine Verstärkungsänderung innerhalb der Signalperiode und damit nichtlineare Verzerrungen. Um dies zu vermeiden, wird die Stromquelle I während und kurz nach jeder Verstärkungsreduktion gesperrt.

With a short release time, a low-frequency input voltage produces a control voltage with a superposed audio frequency (ripple). This results in a gain change within the signal period and consequently non-linear distortions. This is avoided by blocking the current source I during and immediately after each gain reduction.

KOMPRESSIONSVERHAELTNIS (RATIO)

Das Kompressionsverhältnis wird wie die Rücklaufzeit mit einem spannungsgesteuerten Stromverteiler bestimmt. Der gesteuerte Strom ist proportional zur Ausgangsspannung des Logarithmierers. Mit der Spannungssteuerung lässt sich gleichzeitig noch die radiobedingte Grundverstärkung des VCA beeinflussen.

COMPRESSION RATIO

As is the case for the release time, the compression ratio is also determined with a voltage-controlled current distributor. The controlled current is proportional to the output voltage of the logarithmation section. With this voltage control it is also possible to influence the ratio-related basic gain of the VCA.

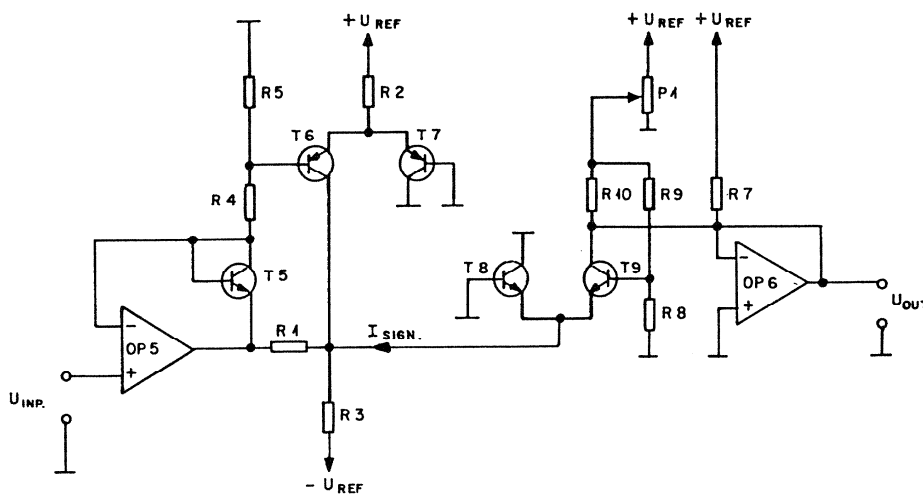

Der linke Teil der obigen Schaltung dient zur Erzeugung des Soft-Limiting Teils der Kompressionskennlinie, d.h. des sanften Uebergangs zwischen unbeeinflusstem und komprimierten Teil der Kennlinie. Der rechte Schaltungsteil bestimmt das Kompressionsverhältnis., wobei an Potentiometer P1 das Ratio eingestellt wird. Der gleichzeitig über R10 nach OP6 fliessende Strom erhöht die Grundverstärkung mit zunehmendem Ratio, was einen gleichbleibenden Lautstärkeindruck bewirkt. Die so gewonnene Steuerspannung gelangt nun über den Schalter COMPR IN auf den Spannungssummierer des VCA, auf den LINK-Bus und das GAIN REDUCTION Meter.

The left-hand section of the above circuit is used for producing the soft-limiting zone of the compression characteristic, i.e. the soft transition between the uninfluenced and compressed zone of the characteristic. The right-hand circuit section determines the compression ratio which is set with potentiometer P1. The current flowing via R10 to OP6 boosts the basic gain with increasing ratios with the effect that a uniform loudness sensation is produced. The control voltage derived in this manner is now taken via the COMPR IN switch to the voltage adder of the VCA, to the LINK bus, and to the GAIN REDUCTION meter.

GAIN REDUCTION METER

Die dB-lineare Anzeige des GRM erfolgt über 10 LED. Der angezeigte Bereich umfasst 14 ...-4 dB in 2 dB Schritten. Bei grossem Ratio und kleinem Eingangssignal wird, wie wir vorher gesehen haben, das Eingangssignal verstärkt. Diese "negative Verstärkungsreduktion" bringt daher die Dioden -2 oder -4 dB zum Aufleuchten.

GAIN REDUCTION METER

The dB-linear display of the GRM is implemented with 10 LEDs. The indicated range covers 14 dB of gain reduction. For high ratios and a small input signal, the input signal is amplified as we have seen before. This "negative gain reduction" causes the diodes -2dB or -4dB to turn on.

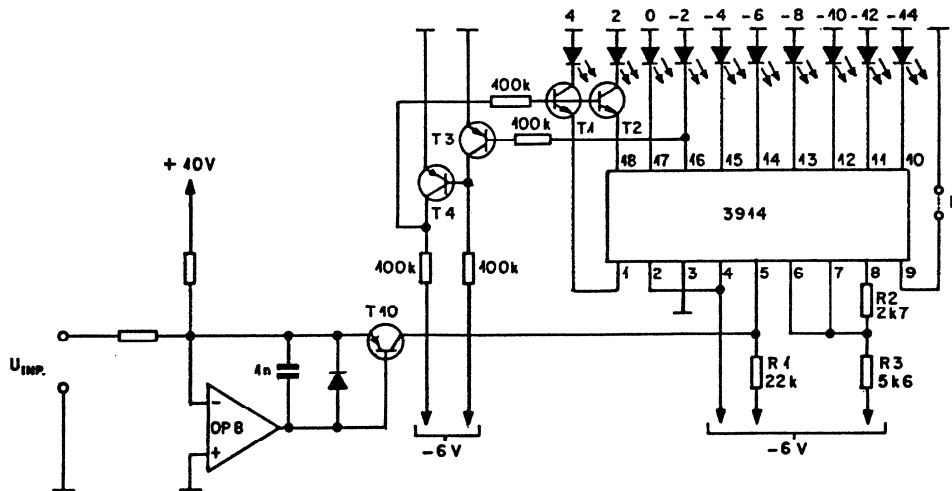

Mit der Brücke K auf obigen GRM Schema kann punktförmige Anzeige in eine Kollonnenförmige umgesetzt werden.

With jumper K, illustrated in the above GRM diagram, a dot-shaped display can be transformed into a column-shaped one.

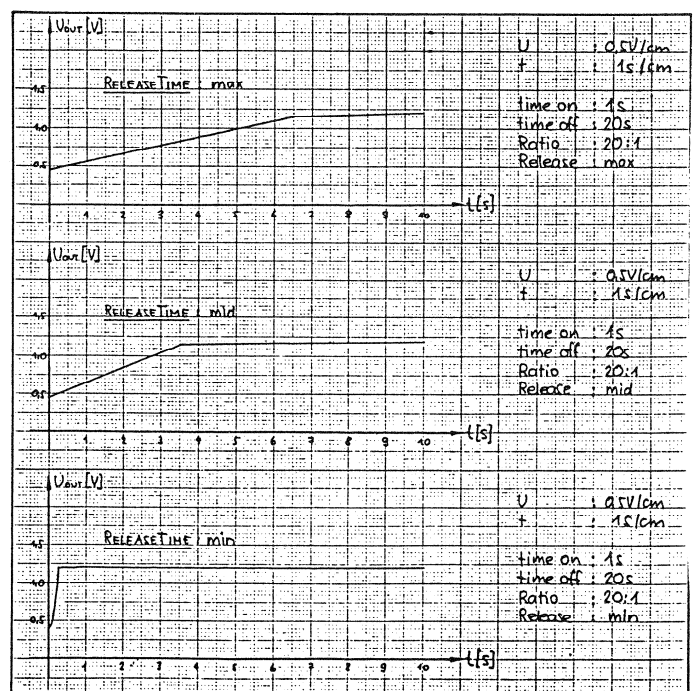
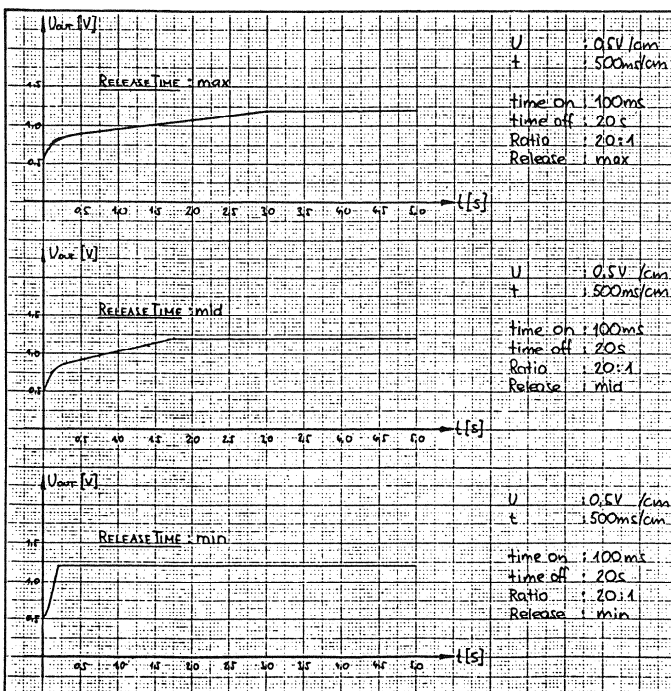
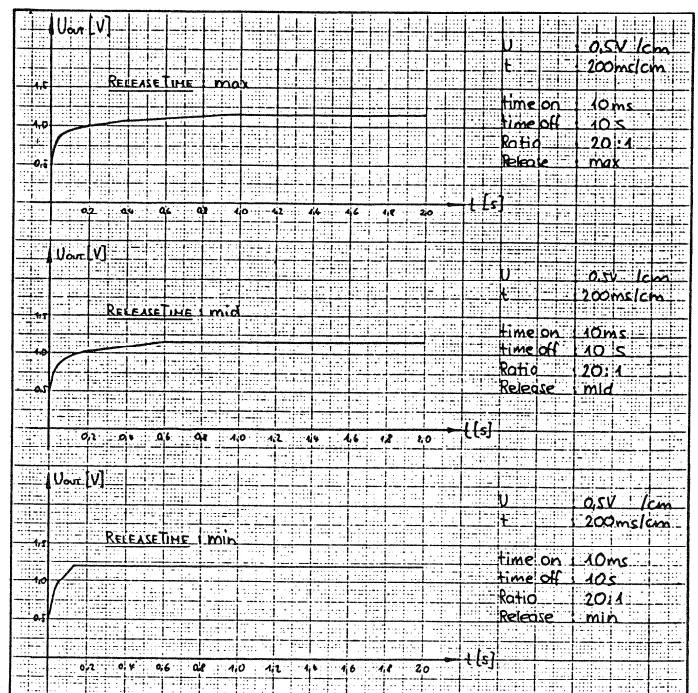
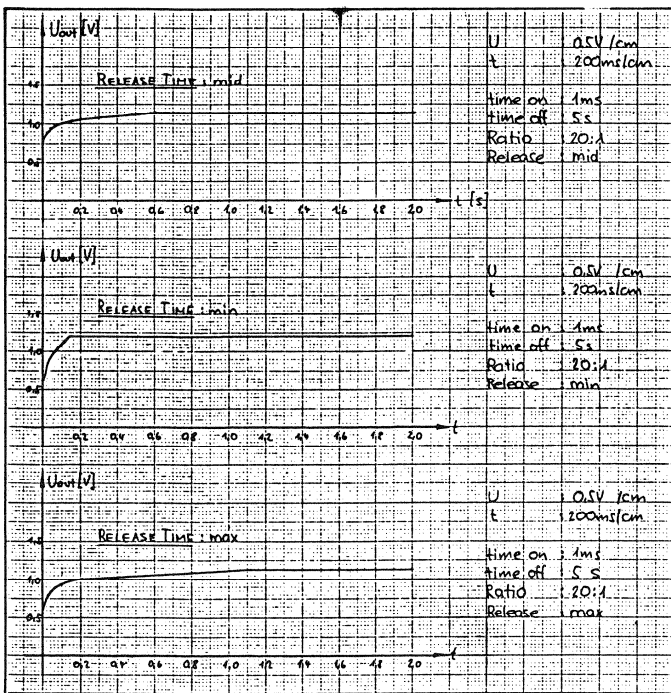
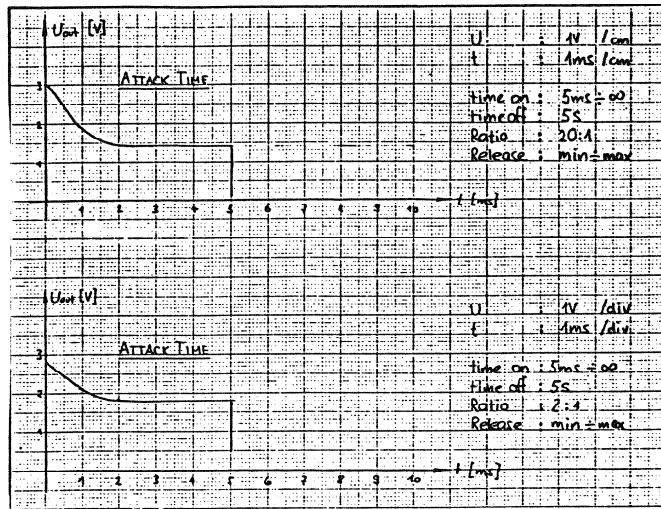

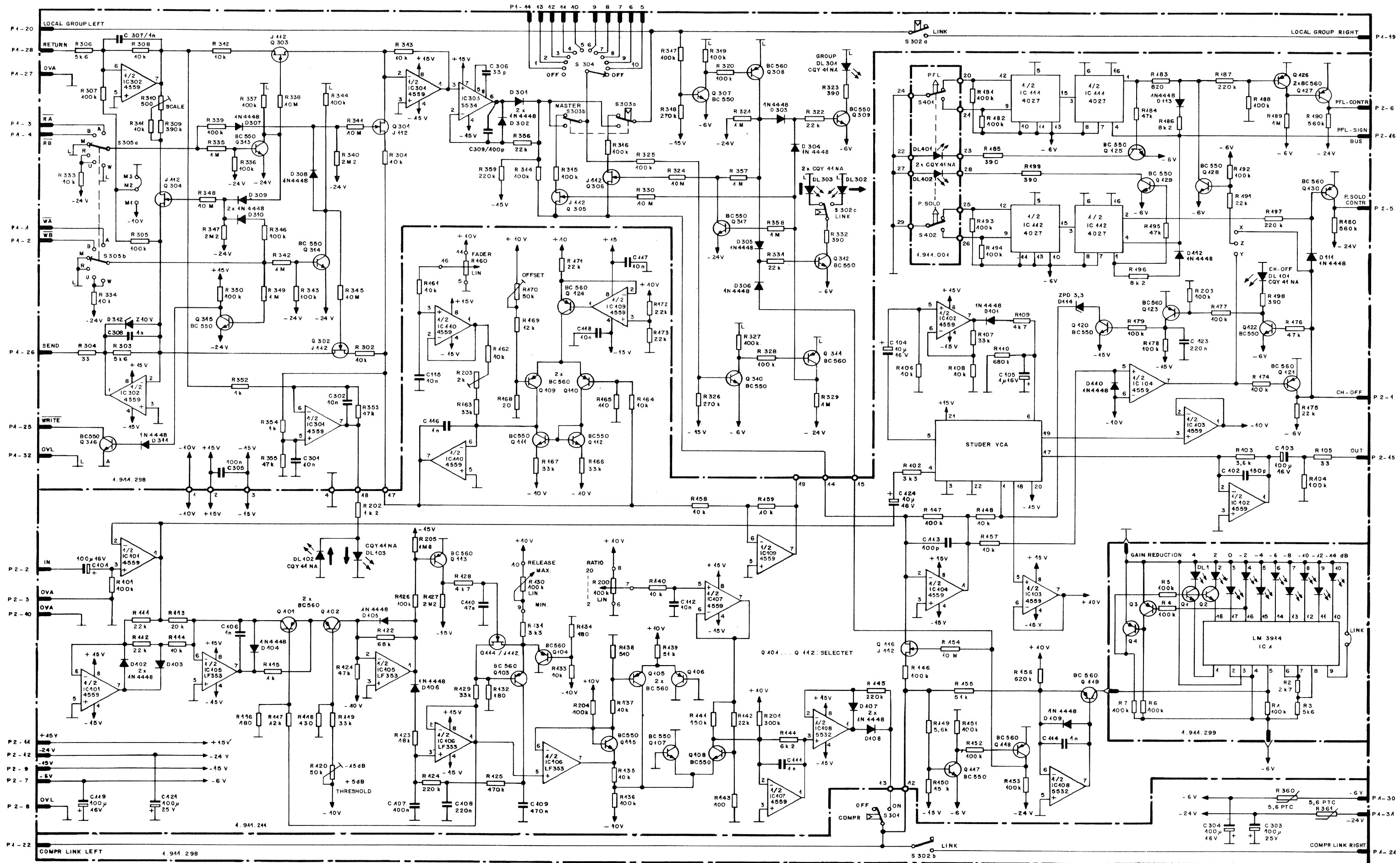

DATE		① 24.1.85	② 5.7.85	③ 21.8.85	④ 30.8.85	⑤ 5.10.85
SIGN:		<i>ml</i>	<i>ml</i>	<i>ml</i>	<i>ml</i>	<i>ml</i>
STUDER REGENSDORF ZÜRICH		VCA - FADER				SC 1.911.210.82

- P 2 - 1 CH-OFF
- P 2 - 2 FADER IN
- P 2 - 3 OVA
- P 2 - 4 SOLO CONTR.
- P 2 - 5 PFL CONTR.
- P 2 - 6 OVL
- P 2 - 7 -16V
- P 2 - 8 OVA
- P 2 - 9 +15V
- P 2 - 10 -24V
- P 2 - 11 FADER OUT
- P 2 - 12 PFL SIGN BUS

- P 4 - 1 WA
- P 4 - 2 WB
- P 4 - 3 RA
- P 4 - 4 RB
- P 4 - 5
- P 4 - 6
- P 4 - 7
- P 4 - 8
- P 4 - 9
- P 4 - 10
- P 4 - 11
- P 4 - 12
- P 4 - 13
- P 4 - 14
- P 4 - 15
- P 4 - 16
- P 4 - 17
- P 4 - 18
- P 4 - 19 LOCAL GR. RIGHT
- P 4 - 20 LOCAL GR. LEFT
- P 4 - 21 COMPR LINK RIGHT
- P 4 - 22 COMPR LINK LEFT
- P 4 - 23
- P 4 - 24
- P 4 - 25 WRITE
- P 4 - 26 SEND
- P 4 - 27 OVA
- P 4 - 28 RETURN
- P 4 - 29 -6V
- P 4 - 30 -24V
- P 4 - 31 OVL
- P 4 - 32

- 1 CH-OFF
- 2 FADER IN
- 3 OVA
- 4 SOLO CONTR.
- 5 PFL CONTR.
- 6 OVL
- 7 -16V
- 8 OVA
- 9 +15V
- 10 -24V
- 11 FADER OUT
- 12 PFL SIGN BUS

- 1 WA
- 2 WB
- 3 RA
- 4 RB
- 5
- 6
- 7
- 8
- 9
- 10
- 11
- 12
- 13
- 14
- 15
- 16
- 17
- 18
- 19 LOCAL GR. RIGHT
- 20 LOCAL GR. LEFT
- 21 COMPR LINK RIGHT
- 22 COMPR LINK LEFT
- 23
- 24
- 25 WRITE
- 26 SEND
- 27 OVA
- 28 RETURN
- 29 -6V
- 30 -24V
- 31 OVL
- 32

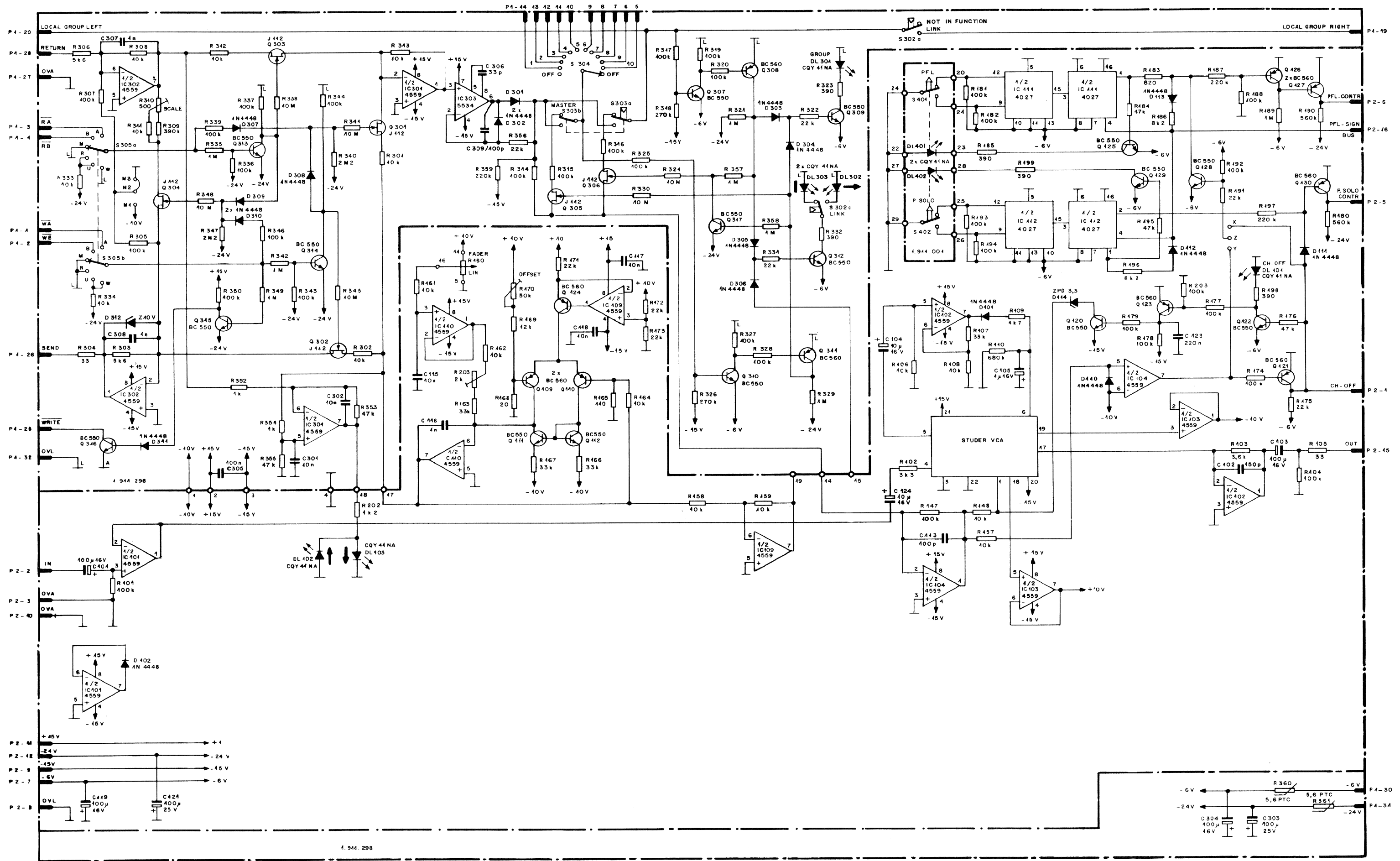

1.944.298

- P.2 CH-OFF
- P.2-1 FADER IN
- P.2-2 OVA
- P.2-3 P. SOLO CONTR.
- P.2-4 PFL CONTR.
- P.2-5 -6V
- P.2-6 OVL
- P.2-7 -45V
- P.2-8 -15V
- P.2-9 +45V
- P.2-10 -24V
- P.2-11
- P.2-12
- P.2-13
- P.2-14 FADER OUT
- P.2-15 PFL SIGN. BUS
- P.4 WA
- P.4-1 WB
- P.4-2
- P.4-3 RA
- P.4-4 RB
- P.4-5
- P.4-6
- P.4-7
- P.4-8
- P.4-9
- P.4-10
- P.4-11
- P.4-12
- P.4-13
- P.4-14
- P.4-15
- P.4-16
- P.4-17
- P.4-18 LOCAL GR. RIGHT
- P.4-19 LOCAL GR. LEFT
- P.4-20 COMP. LINK RIGHT
- P.4-21 COMP. LINK LEFT
- P.4-22
- P.4-23
- P.4-24 WRITE
- P.4-25 SEND
- P.4-26 OVA
- P.4-27 RETURN
- P.4-28 -6V
- P.4-29 -24V
- P.4-30 OVL

DATE	① 24.1.85	② 5.7.85	③ 30.8.85	④ 30.9.85	⑤ 5.10.85
SIGN:	<i>ul</i>	<i>ul</i>	<i>ul</i>	<i>ul</i>	<i>ul</i>
STUDER REGENSDORF ZÜRICH		VCA-FADER			SC 1.911.212.82

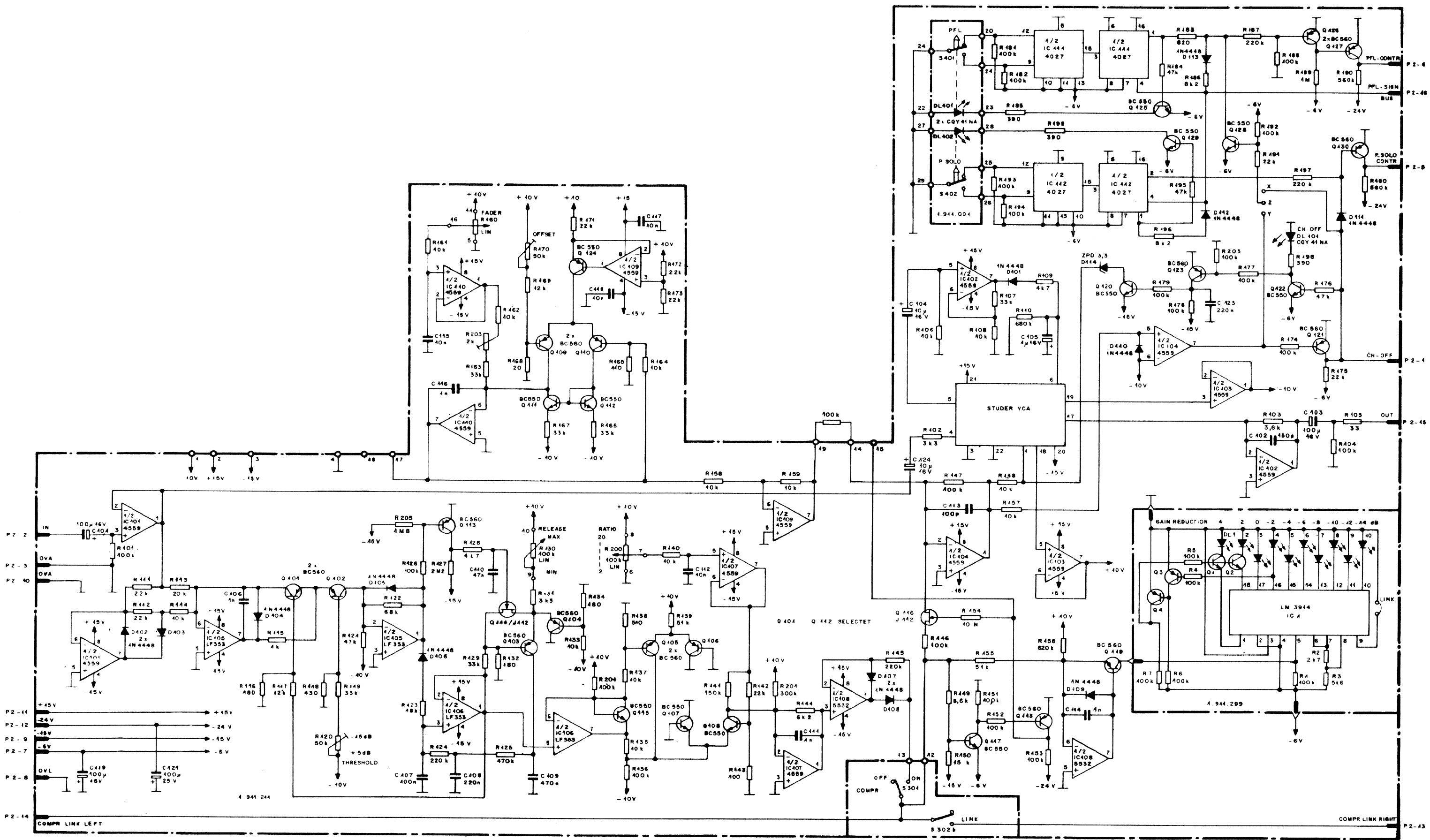

- 1 CH - OFF
- 2 FADER IN
- 3 OVA
- 4 P. SOLO CONTR.
- 5 PFL CONTR.
- 6 -6V
- 7 OVL
- 8 -6V
- 9 OVA
- 10 +15V
- 11 -24V
- 12 -15V
- 13 -6V
- 14 OVL
- 15 -6V
- 16 THRESHOLD
- 17 -10V
- 18 C407 400n
- 19 C408 220n
- 20 C409 470n
- 21 +40V
- 22 +40V
- 23 RELEASE
- 24 RATIO
- 25 MAX
- 26 MIN
- 27 +40V
- 28 +40V
- 29 +40V
- 30 +40V
- 31 +40V
- 32 +40V
- 33 +40V
- 34 +40V
- 35 +40V
- 36 +40V
- 37 +40V
- 38 +40V
- 39 +40V
- 40 +40V
- 41 +40V
- 42 +40V
- 43 +40V
- 44 +40V
- 45 +40V
- 46 +40V
- 47 +40V
- 48 +40V
- 49 +40V
- 50 +40V
- 51 +40V
- 52 +40V
- 53 +40V
- 54 +40V
- 55 +40V
- 56 +40V
- 57 +40V
- 58 +40V
- 59 +40V
- 60 +40V
- 61 +40V
- 62 +40V
- 63 +40V
- 64 +40V
- 65 +40V
- 66 +40V
- 67 +40V
- 68 +40V
- 69 +40V
- 70 +40V
- 71 +40V
- 72 +40V
- 73 +40V
- 74 +40V
- 75 +40V
- 76 +40V
- 77 +40V
- 78 +40V
- 79 +40V
- 80 +40V
- 81 +40V
- 82 +40V
- 83 +40V
- 84 +40V
- 85 +40V
- 86 +40V
- 87 +40V
- 88 +40V
- 89 +40V
- 90 +40V
- 91 +40V
- 92 +40V
- 93 +40V
- 94 +40V
- 95 +40V
- 96 +40V
- 97 +40V
- 98 +40V
- 99 +40V
- 100 +40V

DATE	24.1.85	5.7.85	24.8.85	5.10.85		
SIGN	<i>ul</i>	<i>ul</i>	<i>ul</i>	<i>ul</i>		
STUDER REGENSDORF ZURICH		VCA - FADER			SC 1.911.216.82	

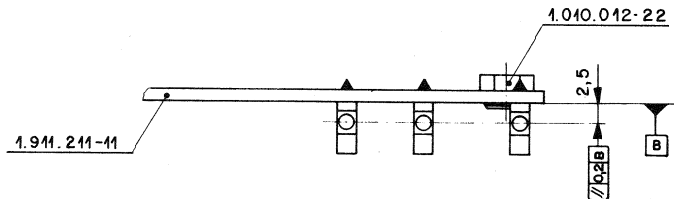
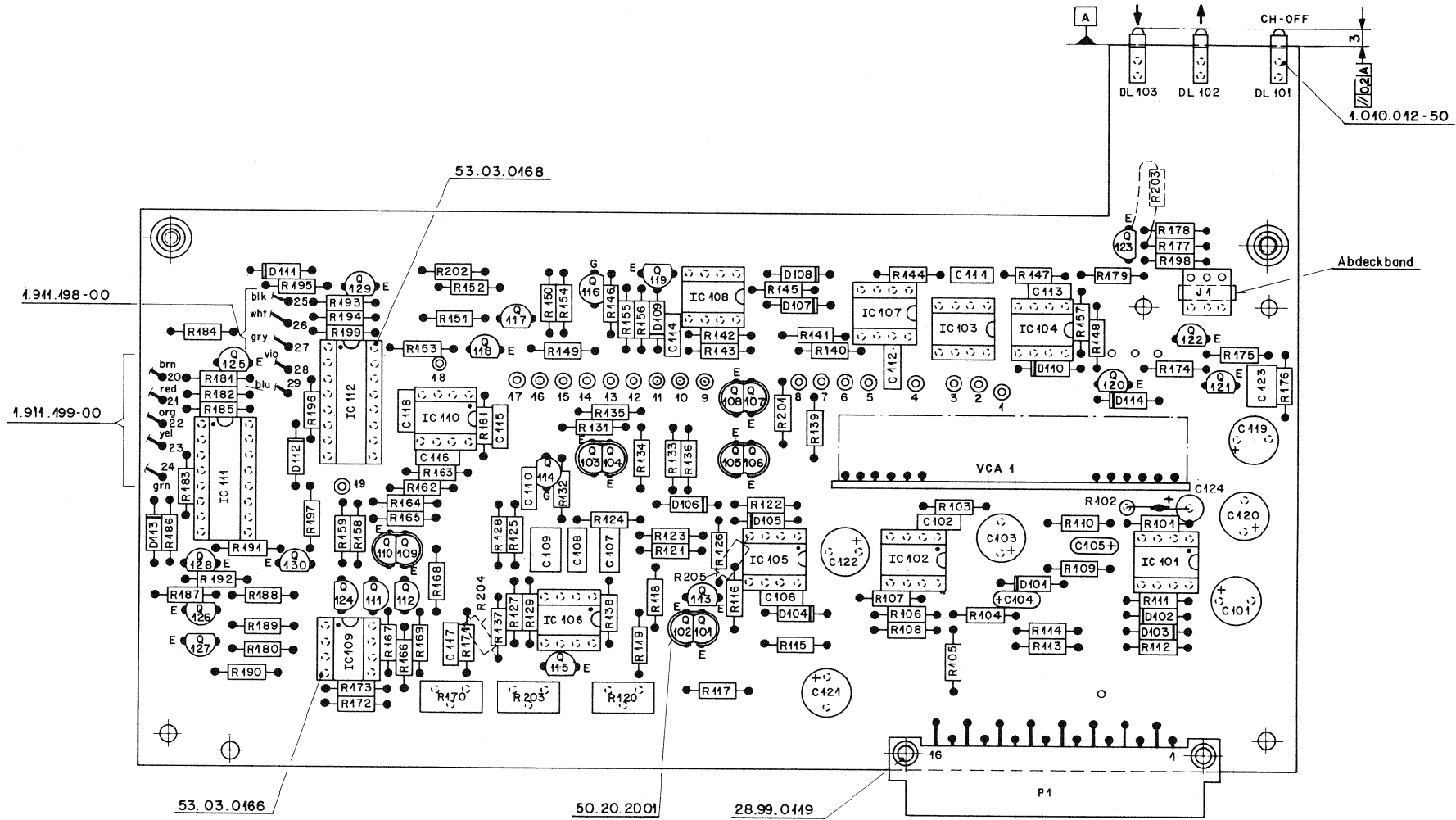

① R 205 neu dazu

Werkstoff	Norm-Nr.:	Güte:						
DIN-Bez.:	Abmessung:	Oberfläche:	Beh.:	Änderung		③		
Zugehörige Unterlagen:	Freimasstoleranz:	Maßstab:	24.1.85 A.Ho		W.	W.	②	
PL	±	2:1	21.8.85 A.Ho		W.	W.	①	
Ersatz für:	Ersetzt durch:	Datum		Gez.	Gepr.	Ges.	Index	
STUDER REGENSDORF ZÜRICH			Benennung: VCA-Fader Board				Nummer: 1.911.211-81	

IND	POS NO	PART NO	VALUE	SPECIFICATIONS/EQUIVALENT	MFR
C	101	59.22.4101	100 μ	16 V EL	
	102	59.34.4151	150 p	CER	
	103	59.22.4101	100 μ	16 V EL	
	104	59.26.2100	10 μ	16 V SAL	
	105	59.26.9109	1 μ	16 V SAL	
	106	59.06.0102	1 n	PETP	
	107	59.06.5104	100 n	PETP	
	108	59.06.5224	220 n	PETP	
	109	59.06.5474	470 n	PETP	
	110	59.06.0473	47 n	PETP	
	111	59.06.0102	1 n	PETP	
	112	59.06.0103	10 n	PETP	
	113	59.34.4101	100 p	CER	
	114	59.06.0102	1 n	PETP	
	115	59.06.0103	10 n	PETP	
	116	59.06.0102	1 n	PETP	
	117	59.06.0103	10 n	PETP	
	118	59.06.0103	10 n	PETP	
	119	59.22.4101	100 μ	16 V EL	
	120			not used	
	121	59.22.5101	100 μ	25 V EL	
	122			not used	
	123	59.06.5224	220 n	PETP	
3	124	59.26.2100	10 μ	16 V SAL	
D	101	50.04.0125	1N4448		
	102	50.04.0125	1N4448		
	103	50.04.0125	1N4448		
	104	50.04.0125	1N4448		
	105	50.04.0125	1N4448		

IND	DATE	NAME	PL	1..911..211..81	PAGE 1 OF 7
④					
③	5.10.85	A.Ho			
②	21.8.85	W.M.			
①	5.7.85	W.M.			
○	24.Jan.85	W.Markl.			
STUDER	VCA-FADER BOARD				

IND	POS NO	PART NO	VALUE	SPECIFICATIONS/EQUIVALENT	MFR
IC	106	50.09.0101	TL072		
	107	50.09.0107	RC4559		
	108	50.09.0105	NE5532		
	109	50.09.0107	RC4559		
	110	50.09.0107	RC4559		
	111	50.07.0027	MC14027		
	112	50.07.0027	MC14027		
J	1	54.01.0287	3 POL	CIS	
Q	101	1.010.038.50	BC560	SEL	
	102	1.010.038.50	BC560	SEL	
	103	1.010.038.50	BC560	SEL	
	104	1.010.038.50	BC560	SEL	
	105	1.010.038.50	BC560	SEL	
	106	1.010.038.50	BC560	SEL	
	107	1.010.039.50	BC550	SEL	
	108	1.010.039.50	BC550	SEL	
	109	1.010.038.50	BC560	SEL	
	110	1.010.038.50	BC560	SEL	
	111	1.010.039.50	BC550	SEL	
	112	1.010.039.50	BC550	SEL	
	113	50.03.0515	BC560		
	114	50.03.0350	J-112		
	115	1.010.039.50	BC550	SEL	
	116	50.03.0350	J-112		
	117	50.03.0436	BC550		
	118	50.03.0515	BC560		
	119	50.03.0515	BC560		
	120	50.03.0436	BC550		

IND	DATE	NAME	PL	1..911..211..81	PAGE 3 OF 7
④					
③	5.7.85	A.Ho			
②	21.8.85	W.M.			
①	5.7.85	W.M.			
○	24.Jan.85	W.Markl.			
STUDER	VCA-FADER BOARD				

IND	POS NO	PART NO	VALUE	SPECIFICATIONS/EQUIVALENT	MFR
D	106	50.04.0125	1N4448		
	107	50.04.0125	1N4448		
	108	50.04.0125	1N4448		
	109	50.04.0125	1N4448		
	110	50.04.0125	1N4448		
	111	50.04.0125	1N4448		
	112	50.04.0125	1N4448		
	113	50.04.0125	1N4448		
	114	50.04.1107	D 3.3V		
DL	101	50.04.2121	ICQY41AN	LED RED	
	102	50.04.2121	ICQY41AN	LED RED	
	103	50.04.2121	ICQY41AN	LED RED	
IC	101	50.09.0107	RC4559		
	102	50.09.0107	RC4559		
	103	50.09.0107	RC4559		
	104	50.09.0107	RC4559		
	105	50.09.0101	TL072		

IND	DATE	NAME	PL	1..911..211..81	PAGE 2 OF 7
④					
③	5.10.85	A.Ho			
②	21.8.85	W.M.			
①	5.7.85	W.M.			
○	24.Jan.85	W.Markl.			
STUDER	VCA-FADER BOARD				

IND	POS NO	PART NO	VALUE	SPECIFICATIONS/EQUIVALENT	MFR
Q	121	50.03.0515	BC560		
	122	50.03.0436	BC550		
	123	50.03.0515	BC560		
	124	50.03.0515	BC560		
	125	50.03.0436	BC550		
	126	50.03.0515	BC560		
	127	50.03.0515	BC560		
	128	50.03.0436	BC550		
	129	50.03.0436	BC550		
	130	50.03.0515	BC560		
P	1	54.11.2007	2*8PIN		
R	101	57.11.4104	100 K		
	102	57.11.3362	3.6 K		
	103	57.11.4332	3.3 K		
	104	57.11.4104	100 K		
	105	57.11.4330	33		
	106	57.11.4103	10 K		
	107	57.11.4333	33 K		
	108	57.11.4103	10 K		
	109	57.11.4472	4.7 K		
	110	57.11.4684	680 K		
	111	57.11.4223	22 K		
	112	57.11.4223	22 K		
	113	57.11.3203	20 K		
	114	57.11.4103	10 K		
	115	57.11.4102	1 K		
	116	57.11.4181	180		
	117	57.11.4123	12 K		

IND	DATE	NAME	PL	1..911..211..81	PAGE 4 OF 7
④					
③	5.10.85	A.Ho			
②	21.8.85	W.M.			
①	5.7.85	W.M.			
○	24.Jan.85	W.Markl.			
STUDER	VCA-FADER BOARD				

IND	POS NO	PART NO	VALUE	SPECIFICATIONS/EQUIVALENT	MFR
R	118	57.11.3431	430		
	119	57.11.4333	33 K		
	120	58.01.9503	50 K	TRIM PMG	
	121	57.11.4473	47 K		
	122	57.11.4683	68 K		
	123	57.11.4183	18 K		
	124	57.11.4224	220 K		
	125	57.11.4474	470 K		
	126	57.11.4104	100 K		
	127	57.11.5225	2.2 M		
	128	57.11.4472	4.7 K		
	129	57.11.4333	33 K		
	130	58.03.0104	100 K	LIN POT PCC (on 1.911.210)	
	131	57.11.4332	3.3 K		
	132	57.11.4181	180		
	133	57.11.4103	10 K		
	134	57.11.4181	180		
	135	57.11.4103	10 K		
	136	57.11.4104	100 K		
	137	57.11.4103	10 K		
	138	57.11.3511	510		
	139	57.11.3513	51 K		
	140	57.11.4103	10 K		
	141	57.11.4154	150 K		
	142	57.11.4223	22 K		
	143	57.11.4101	100		
	144	57.11.3622	6.2 K		
	145	57.11.4224	220 K		
	146	57.11.4104	100 K		
	147	57.11.4104	100 K		

IND	POS NO	PART NO	VALUE	SPECIFICATIONS/EQUIVALENT	MFR
R	178	57.11.4104	100 K		
	179	57.11.4104	100 K		
	180	57.11.4564	560 K		
	181	57.11.4104	100 K		
	182	57.11.4104	100 K		
	183	57.11.4821	820		
	184	57.11.4473	47 K		
	185	57.11.4391	390		
	186	57.11.4822	8.2 K		
	187	57.11.4224	220 K		
	188	57.11.4104	100 K		
	189	57.11.4105	1 M		
	190	57.11.4564	560 K		
	191	57.11.4223	22 K		
	192	57.11.4104	100 K		
	193	57.11.4104	100 K		
	194	57.11.4104	100 K		
	195	57.11.4473	47 K		
	196	57.11.4822	8.2 K		
	197	57.11.4224	220 K		
	198	57.11.4391	390		
	199	57.11.4391	390		
	200	58.03.0104	100 K	LIN POT PCC (on 1.911.210)	
	201	57.11.3304	300 K		
	202	57.11.4122	1.2 K		
	203	57.11.4104	100 K		
	204	57.11.4104	100 K		
	VCA1	1.010.110.50		STUDER VCA	
2	205	57.11.5185	1.8 M		
	MPQ	50.20.2001		CLIP, 2* TO 92	

IND	DATE	NAME
④		
③	5.10.85	A. Ko
②	21.8.85	W
①	5.7.85	W
○	24. Jan. 85	W. Markl

STUDER VCA-FADER BOARD PL 1.911.211.81 PAGE 5 OF 7

IND	DATE	NAME
④		
③	5.10.85	A. Ko
②	21.8.85	W
①	5.7.85	W
○	24. Jan. 85	W. Markl

STUDER VCA-FADER BOARD PL 1.911.211.81 PAGE 7 OF 7

IND	POS NO	PART NO	VALUE	SPECIFICATIONS/EQUIVALENT	MFR
R	148	57.11.4103	10 K		
	149	57.11.4562	5.6 K		
	150	57.11.4153	15 K		
	151	57.11.4104	100 K		
	152	57.11.4104	100 K		
	153	57.11.4104	100 K		
	154	57.11.6101	10 M		
	155	57.11.3513	51 K		
	156	57.11.3624	620 K		
	157	57.11.4103	10 K		
	158	57.11.4103	10 K		
	159	57.11.4103	10 K		
1	160	1.960.029.00	10 K	FADER TRACK LIN.	
	161	57.11.4103	10 K		
2	162	57.11.4103	10 K		
	163	57.11.4333	33 K		
	164	57.11.4104	10 K		
	165	57.11.3111	110		
	166	57.11.4333	33 K		
	167	57.11.4333	33 K		
	168	57.11.3200	20		
	169	57.11.4123	12 K		
	170	58.01.9503	50 K	TRIM PMG	
	171	57.11.4223	22 K		
	172	57.11.4223	22 K		
	173	57.11.4223	22 K		
	174	57.11.4104	100 K		
	175	57.11.4223	22 K		
	176	57.11.4473	47 K		
	177	57.11.4104	100 K		

IND	DATE	NAME
④		
③	5.10.85	A. Ko
②	21.8.85	W
①	5.7.85	W
○	24. Jan. 85	W. Markl

STUDER VCA-FADER BOARD PL 1.911.211.81 PAGE 6 OF 7

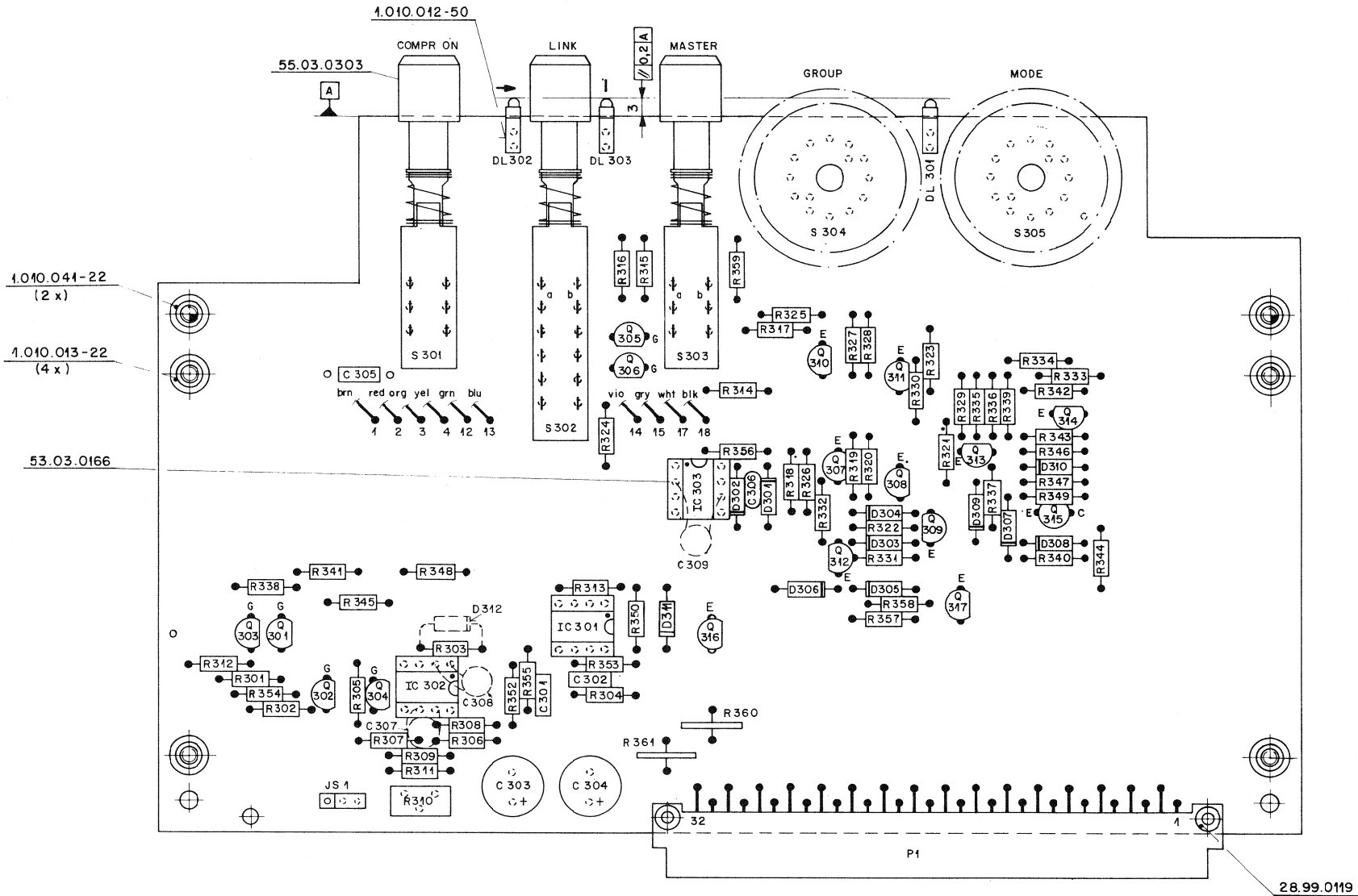

- ① C 307, C 308, C 309 neu dazu
- ② D 312 neu dazu

Werkstoff Norm-Nr.: DIN-Bez.: Abmessung:		Güte: Oberfläche: Beh:		Änderung 30.9.85 A.Ho 30.8.85 A.Ho	
Zugehörige Unterlagen: PL,LL		Freimasstoleranz:	Maßstab: 2:1		Ausgabe 24.1.85 A.Ho Datum Gez Gepr Gcs Index
Ersatz für:		Ersetzt durch:		Kopie für:	
Benennung: STUDEF REGENDORF ZÜRICH		Automations Board			Benennung: 1.911.298-81

IND	POS NO	PART NO	VALUE	SPECIFICATIONS/EQUIVALENT	MFR
C	301	59.06.0103	10n	PETP	
	302	59.06.0103	10n	PETP	
	303	59.22.5101	100µ	25V EL	
	304	59.22.4101	100µ	16V EL	
	305	59.06.5104	100n	PETP	
	306	59.34.2330	33p	CER	
1	307	59.32.4102	1n	CER	
1	308	59.32.4102	1n	CER	
1	309	59.34.4101	400p	CER	
D	301	50.04.0125	1N4448		
	302	50.04.0125	1N4448		
	303	50.04.0125	1N4448		
	304	50.04.0125	1N4448		
	305	50.04.0125	1N4448		
	306	50.04.0125	1N4448		
	307	50.04.0125	1N4448		
	308	50.04.0125	1N4448		
	309	50.04.0125	1N4448		
	310	50.04.0125	1N4448		
	311	50.04.0125	1N4448		
2	312	50.04.1114	10V	Z-DIODE	
DL	301	50.04.2121	CQY41AN	LED ROT	
	302	50.04.2121	CQY41AN	LED ROT	
	303	50.04.2121	CQY41AN	LED ROT	
JS	1	54.11.0126	3PIN	JUMPER	
IC	301	50.09.0107	RC4559		
	302	50.09.0107	RC4559		
	303	50.05.0243	NE5534M		
P	1	54.01.0359	2*16PIN	EUROCONNECTOR	

IND	DATE	NAME
④		
③		
②	30.Sept.85	A.Ho
①	30.Aug.85	A.Ho
○	24.Jan.85	W.Markl

STUDER AUTOMATION BOARD PL 1..9.1.1..298..81 PAGE 1 OF 4

IND	POS NO	PART NO	VALUE	SPECIFICATIONS/EQUIVALENT	MFR
R	311	57.11.4103	10 K		
	312	57.11.4103	10 K		
	313	57.11.4103	10 K		
	314	57.11.4104	100 K		
	315	57.11.4104	100 K		
	316	57.11.4104	100 K		
	317	57.11.4104	100 K		
	318	57.11.4274	270 K		
	319	57.11.4104	100 K		
	320	57.11.4104	100 K		
	321	57.11.4105	1 M		
	322	57.11.4223	22 K		
	323	57.11.4391	390		
	324	57.11.6106	10 M		
	325	57.11.4104	100 K		
	326	57.11.4274	270 K		
	327	57.11.4104	100 K		
	328	57.11.4104	100 K		
	329	57.11.4105	1 M		
	330	57.11.6106	10 M		
	331	57.11.4223	22 K		
	332	57.11.4391	390		
	333	57.11.4103	10 K		
	334	57.11.4103	10 K		
	335	57.11.4105	1 M		
	336	57.11.4104	100 K		
	337	57.11.4104	100 K		
	338	57.11.6106	10 M		
	339	57.11.4104	100 K		
	340	57.11.5225	2.2 M		

IND	DATE	NAME
④		
③		
②	30.Sept.85	A.Ho
①	30.Aug.85	A.Ho
○	24.Jan.85	W.Markl

STUDER AUTOMATION BOARD PL 1..9.1.1..298..81 PAGE 3 OF 4

IND	POS NO	PART NO	VALUE	SPECIFICATIONS/EQUIVALENT	MFR
Q	301	50.03.0350	J112		
	302	50.03.0350	J112		
	303	50.03.0350	J112		
	304	50.03.0350	J112		
	305	50.03.0350	J112		
	306	50.03.0350	J112		
	307	50.03.0436	BC550		
	308	50.03.0515	BC560		
	309	50.03.0436	BC550		
	310	50.03.0436	BC550		
	311	50.03.0515	BC560		
	312	50.03.0436	BC550		
	313	50.03.0436	BC550		
	314	50.03.0436	BC550		
	315	50.03.0436	BC550		
	316	50.03.0436	BC550		
	317	50.03.0436	BC550		
R	301	57.11.4103	10 K		
	302	57.11.4103	10 K		
	303	57.11.4562	5.6 K		
	304	57.11.4330	33		
	305	57.11.4104	100 K		
	306	57.11.4562	5.6 K		
	307	57.11.4104	100 K		
	308	57.11.4103	10 K		
	309	57.11.4394	390 K		
	310	58.01.9501	500	TRIMM PMG	

IND	DATE	NAME
④		
③		
②	30.Sept.85	A.Ho
①	30.Aug.85	A.Ho
○	24.Jan.85	W.Markl

STUDER AUTOMATION BOARD PL 1..9.1.1..298..81 PAGE 2 OF 4

IND	POS NO	PART NO	VALUE	SPECIFICATIONS/EQUIVALENT	MFR
R	341	57.11.6106	10 M		
	342	57.11.4105	1 M		
	343	57.11.4104	100 K		
	344	57.11.4104	100 K		
	345	57.11.6106	10 M		
	346	57.11.4104	100 K		
	347	57.11.5225	2.2 M		
	348	57.11.6106	10 M		
	349	57.11.4105	1 M		
	350	57.11.4104	100 K		
	351				
	352	57.11.4102	1 K		
1	353	57.11.4473	47 K		
	354	57.11.4102	1 K		
1	355	57.11.4473	47 K		
	356	57.11.4223	22 K		
	357	57.11.4105	1 M		
	358	57.11.4105	1 M		
	359	57.11.4224	220 K		
	360	57.99.0209	5.6	PTC	
	361	57.99.0209	5.6	PTC	
S	301	55.15.0002	2*U	TASTE	
	302	55.15.0004	4*U	TASTE	
	303	55.15.0002	2*U	TASTE	
	304	55.13.0011	1*12	SCHALTER U	
	305	55.13.0010	2*6	SCHALTER KS	

IND	DATE	NAME
④		
③		
②	30.Sept.85	A.Ho
①	30.Aug.85	A.Ho
○	24.Jan.85	W.Markl

STUDER AUTOMATION BOARD PL 1..9.1.1..298..81 PAGE 4 OF 4

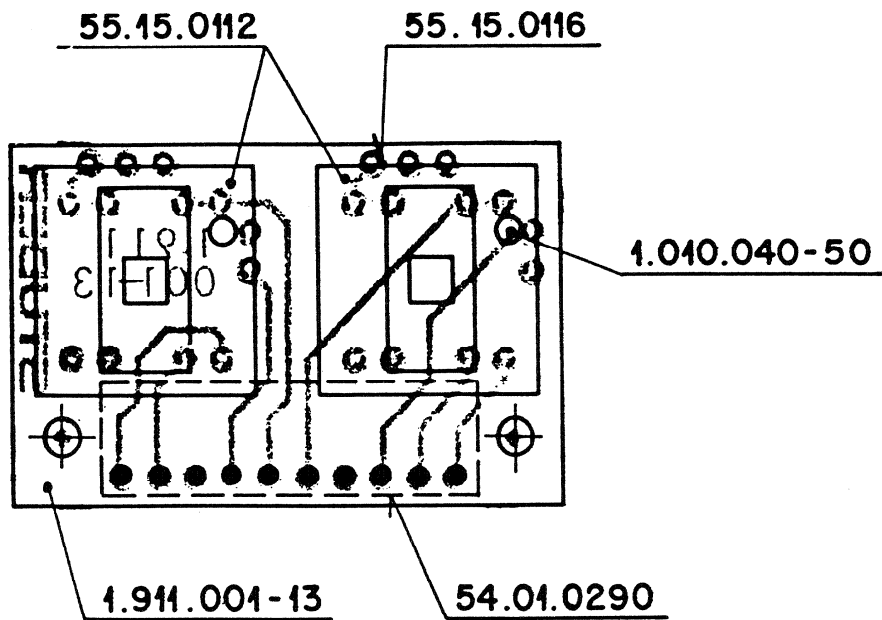

Werkstoff	Norm-Nr.:	Oberfläche	Güte:	Änderung					③	
	DIN-Bez.:		Beh.:							②
	Abmessung:									①
Zugehörige Unterlagen:		Freimasstoleranz:	Maßstab:	Ausgabe	19.5.82	Ho	Vf		①	
		±	2 : 1	Datum	Gez.	Gepr.	Ges.	Index		
Ersatz für:		Ersetzt durch:		Kopie für:						
STUDER REGENSDORF ZÜRICH		Benennung: Pushbutton Board N-N			Nummer: 1.911.001-00					

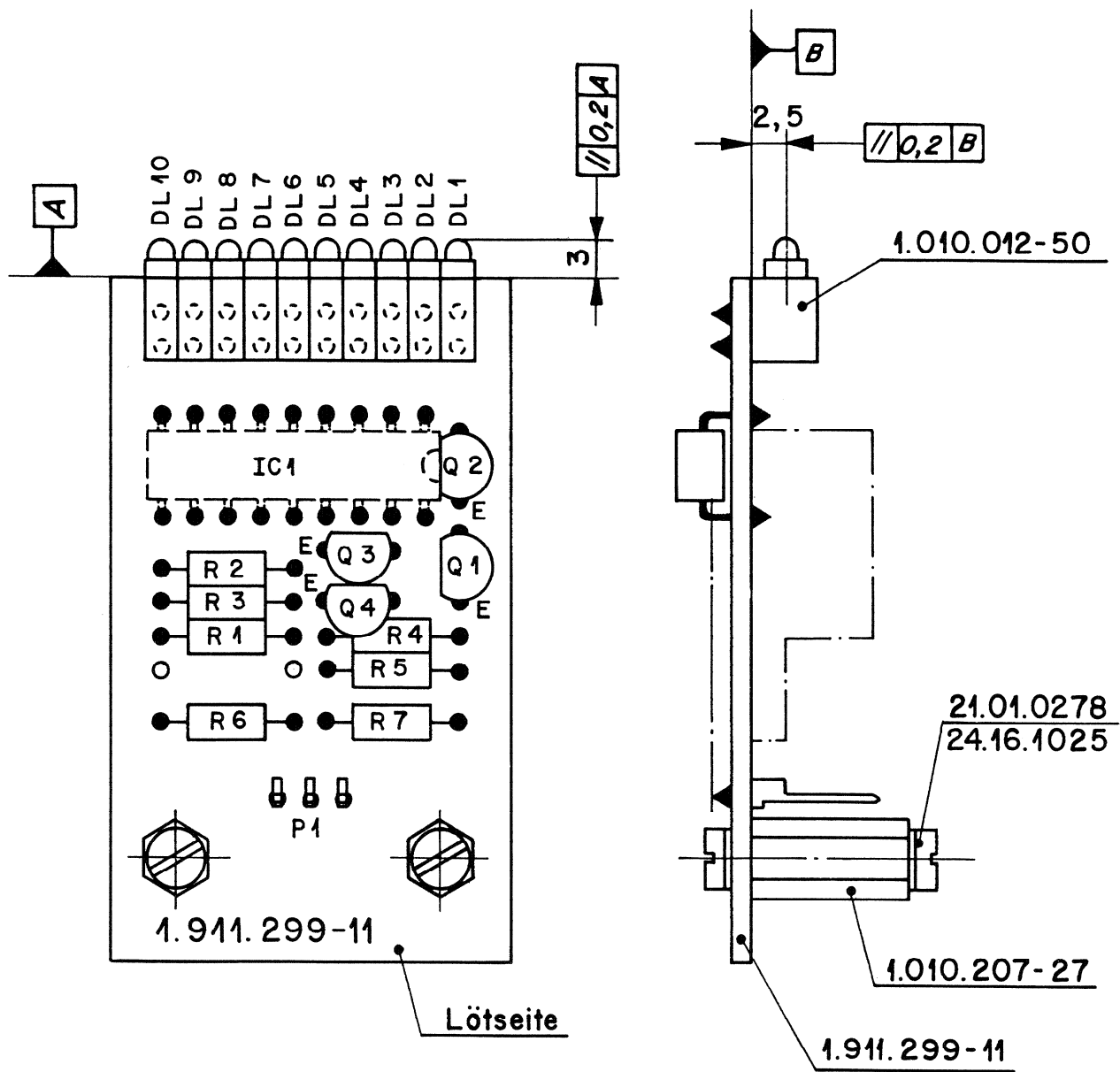

Werkstoff	Norm-Nr.:	Oberfläche		Güte:					③
	DIN-Bez.:	Beh.:							②
	Abmessung:								①
Zugehörige Unterlagen:		Freimasstoleranz:	Maßstab:	Ausgabe	14.7.83	A.Ho	W.M.		④
PL		+	2:1	Datum	Gez.	Gepr.	Ges.	Index	
Ersatz für:		Ersetzt durch:		Kopie für:					
STUDER REGENDORF ZÜRICH		Benennung: Led-GRM Board			Nummer: 1.911.299-00				

IND	POS NO	PART NO	VALUE	SPECIFICATIONS/EQUIVALENT	MFR
	DL 1	50.04.2132	CQY73N	LED GREEN	
	2	50.04.2132	CQY73N	LED GREEN	
	3	50.04.2132	CQY73N	LED GREEN	
	4	50.04.2121	CQY41NA	LED RED	
	5	50.04.2121	CQY41NA	LED RED	
	6	50.04.2121	CQY41NA	LED RED	
	7	50.04.2121	CQY41NA	LED RED	
	8	50.04.2121	CQY41NA	LED RED	
	9	50.04.2121	CQY41NA	LED RED	
	10	50.04.2121	CQY41NA	LED RED	
	IC 1	50.11.0119	LM3914		
	Q 1	50.03.0436	BC237		
	2	50.03.0436	BC237		
	3	50.03.0515	BC307		
	4	50.03.0515	BC307		
	R 1	57.11.4104	100 K		
	2	57.11.4272	2,7 K		
	3	57.11.4562	5,6 K		
	4	57.11.4104	100 K		
	5	57.11.4104	100 K		
	6	57.11.4104	100 K		
	7	57.11.4104	100 K		
	P 1	54.01.0313	3 POL		

IND	DATE	NAME			
④					
③					
②					
①					
○	26.10.82	W.Markl			
STUDER		LED-GAIN-REDUCTION-METER	PL	1.911.299.00	PAGE 1 OF 1

VCA FADER AK

1. 911.220.00

Blockschaltbild

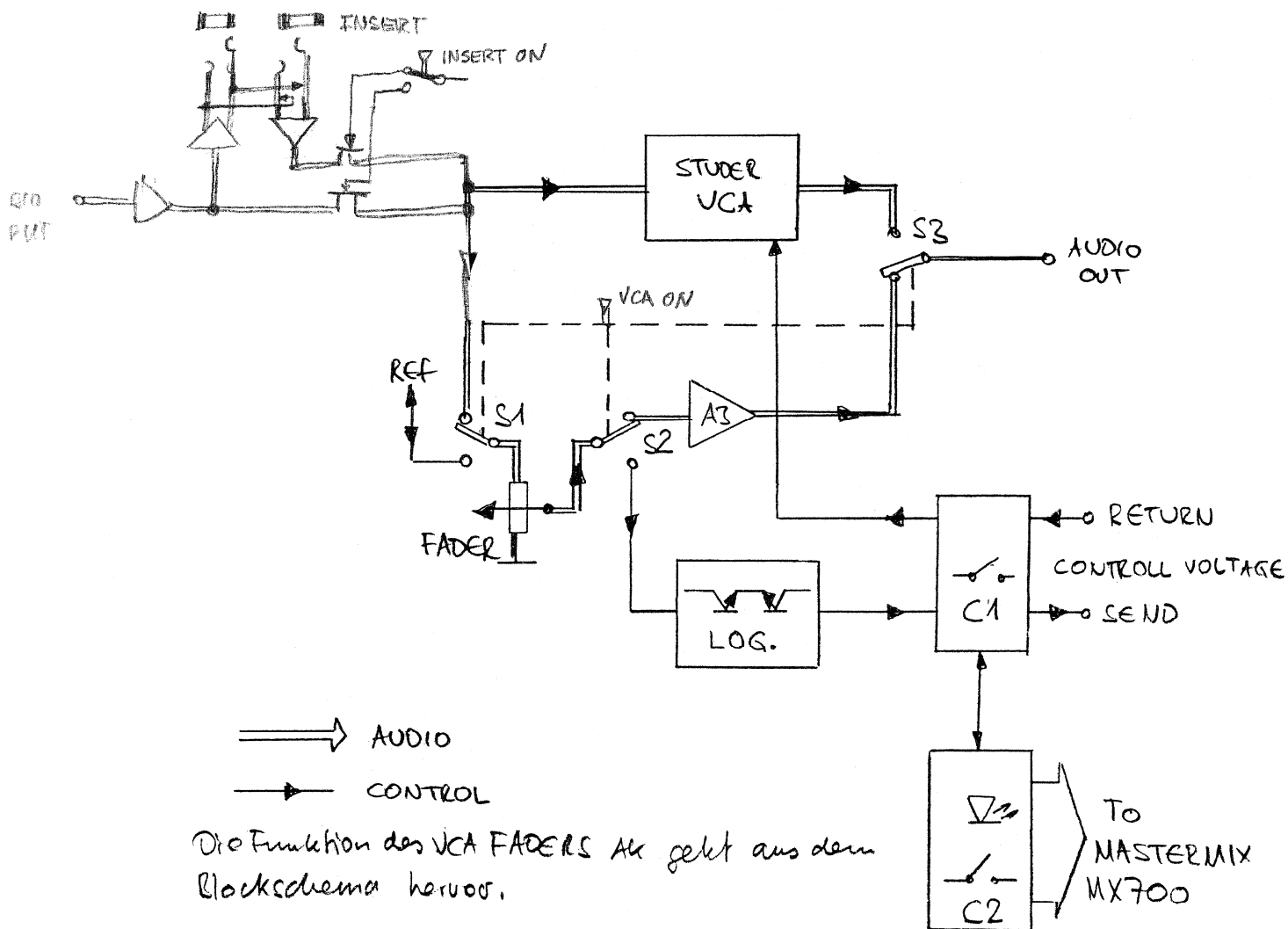

Die Funktion des VCA FADERS AK geht aus dem Blockschema hervor.

Funktionsbeschreibung

Das Audiosignal fließt über A1, einem Symmetrierer, auf den Insertpunkt INSERT und von dort zurück auf den symmetrischen Eingang A2. Dessen Ausgang speist den STUDER-VCA und bei gezeigter Schalterstellung von S1 den FADER. Das Signal fließt nun vom Faderabgriff über Schalter S2 auf den Verstärker A3 über S3 auf den Ausgang.

Bei der anderen Schalterstellung wird das Audiosignal vom Ausgang des VCA auf den AUDIO-Ausgang geleitet.

Der Fader wird dann mit einer Referenzspannung gespeist. Die Spannung am Schleifer wird über einen Logarithmimeter LOG der Kennlinie des VCA angepasst. Diese Steuerspannung wird nun über einen Analogschalter C1 auf das Automationsystem gesendet. Von dort gelangt es zurück über C1 auf den VCA.

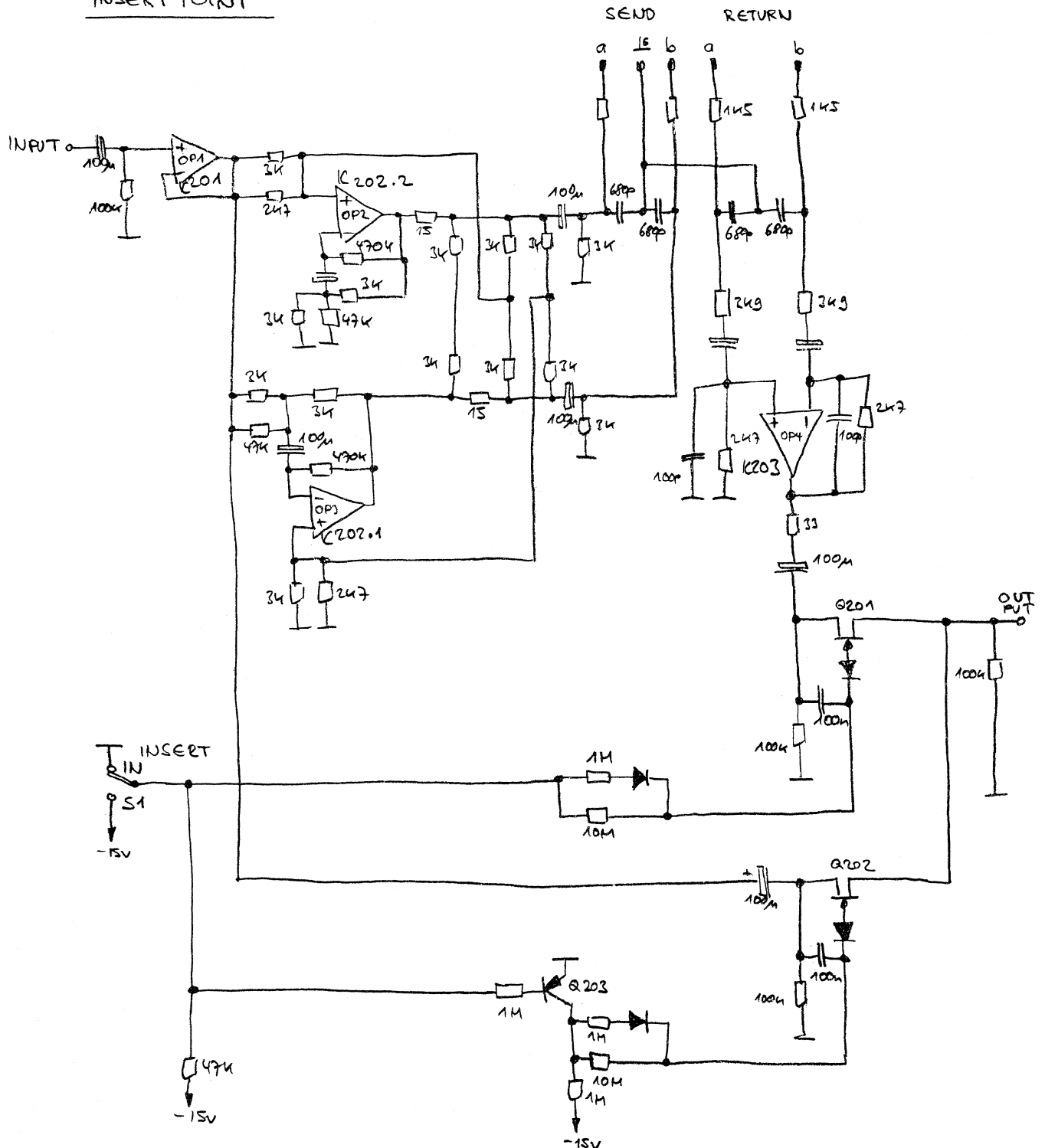
INSERT POINT

Das Audiosignal wird mit OP1 (IC201) gepuffert an den Symmetrierverstärker OP2 (OP3) (IC202) und den Schaltzweig Q202 geliefert. Wenn der Schalter INSERT IN geschaltet ist, leitet Q202 das Audiosignal zum Ausgang. Das symmetrische Signal kommt vom Insertpunkt auf den symmetrischen Eingang RETURN zurück und wird mit dem OP4 (IC203) entkoppelt. Ist der Schalter INSERT IN nicht betätigt, leitet Q201 das Return-Signal zum Ausgang, während Q202 sperrt.

Damit das Umschalten knopflos erfolgt, werden die Fets jeweils rasch eingeschaltet und langsam ausgeschaltet.

FADER und VCA

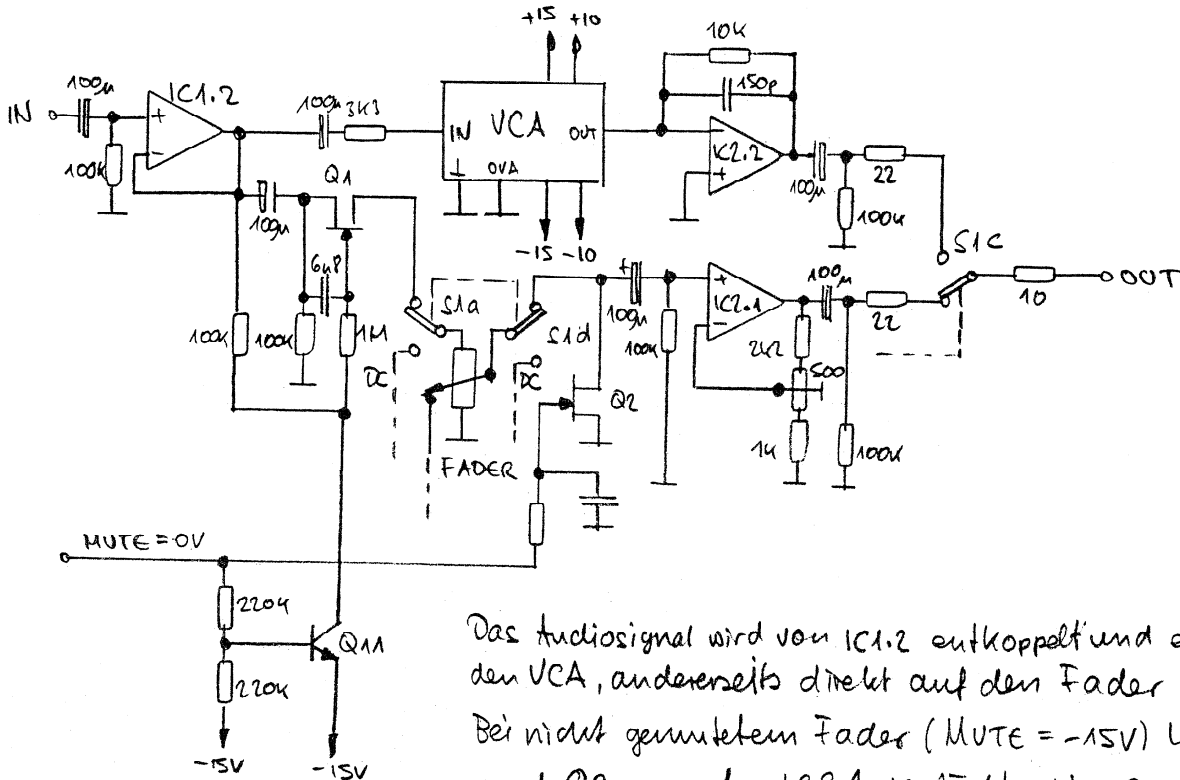

Das Audiosignal wird von IC1.2 entkoppelt und einerseits auf den VCA, andererseits direkt auf den Fader geleitet. Bei nicht gedrücktem Fader (MUTE = -15V) leitet Q1 und Q2 sperrt. IC2.1 verstärkt die Spannung vom Schalter und sendet diese über den Schalter S1C an den Ausgang OUT. Wird hingegen S1 gedrückt, dann gelangt das Audiosignal vom Ausgang des VCA über IC2.2 an den Schalter S1C zum Ausgang OUT. In diesem Zustand ist IC2.1 mit dem 100kΩ Widerstand am Eingang gegen Masse geschaltet. Der Ausgang bleibt unbelastet. Wird die MUTE Leitung = 0V, dann leitet Q2 und Q11. Q11 legt somit eine negative Spannung an das Gate von Q1, so dass dieser sperrt. Der Fader ist somit abgekoppelt. ⇒ MUTE

Schleifer und sendet diese über den Schalter S1C an den Ausgang OUT. Wird hingegen S1 gedrückt, dann gelangt das Audiosignal vom Ausgang des VCA über IC2.2 an den Schalter S1C zum Ausgang OUT. In diesem Zustand ist IC2.1 mit dem 100kΩ Widerstand am Eingang gegen Masse geschaltet. Der Ausgang bleibt unbelastet.

Wird die MUTE Leitung = 0V, dann leitet Q2 und Q11. Q11 legt somit eine negative Spannung an das Gate von Q1, so dass dieser sperrt. Der Fader ist somit abgekoppelt. ⇒ MUTE

LOGARITHMIERER

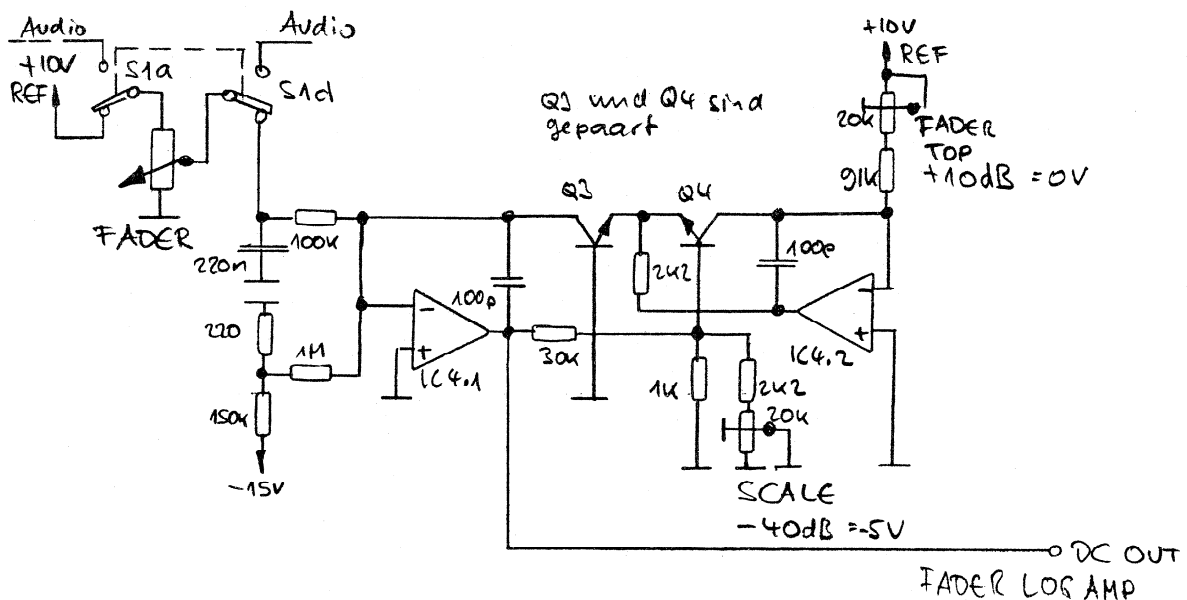

Wenn der Schalter S1 gedrückt ist, dann wird über S1 a eine Referenzspannung von +10V an den FADER gelegt. Die Ausgangsspannung des Faders gelangt dann über S1 d auf den Logarithmierer. Der 220nF Kondensator an dessen Eingang glättet die DC-Spannung die der Fader liefert von Störungen die beim Betätigen entstehen können.

Die nächste Abbildung zeigt das Prinzipschaltbild eines Logarithmierers.

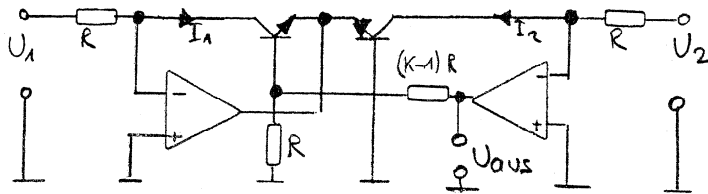

Die Ausgangsspannung folgt der Gleichung

$$\underline{\underline{U_{aus} = -k \cdot U_T \cdot \ln\left(\frac{U_1}{U_2}\right)}}$$

Beim Logarithmierer im VCA FADER AK ist nun $U_1 = +10V$ die Referenzspannung, Da die temperaturabhängige Spannung U_T einen Fehler bei Temperaturänderungen verursacht, wird die Referenzspannung dazu umgekehrtproportional temperaturabhängig gemacht.

Dies kompensiert diesen Fehler.

Damit nun, wenn der Fader gegen $-\infty$ eingestellt ist, die Ausschalt-dämpfung sicher erreicht wird, wird zum Eingangsstrom noch ein kleiner negativer Beitrag hinzugefügt. Dies bewirkt bei ca. $-60dB$ ein sicheres ausschalten des Logarithmierers.

Analogschalter und Automation

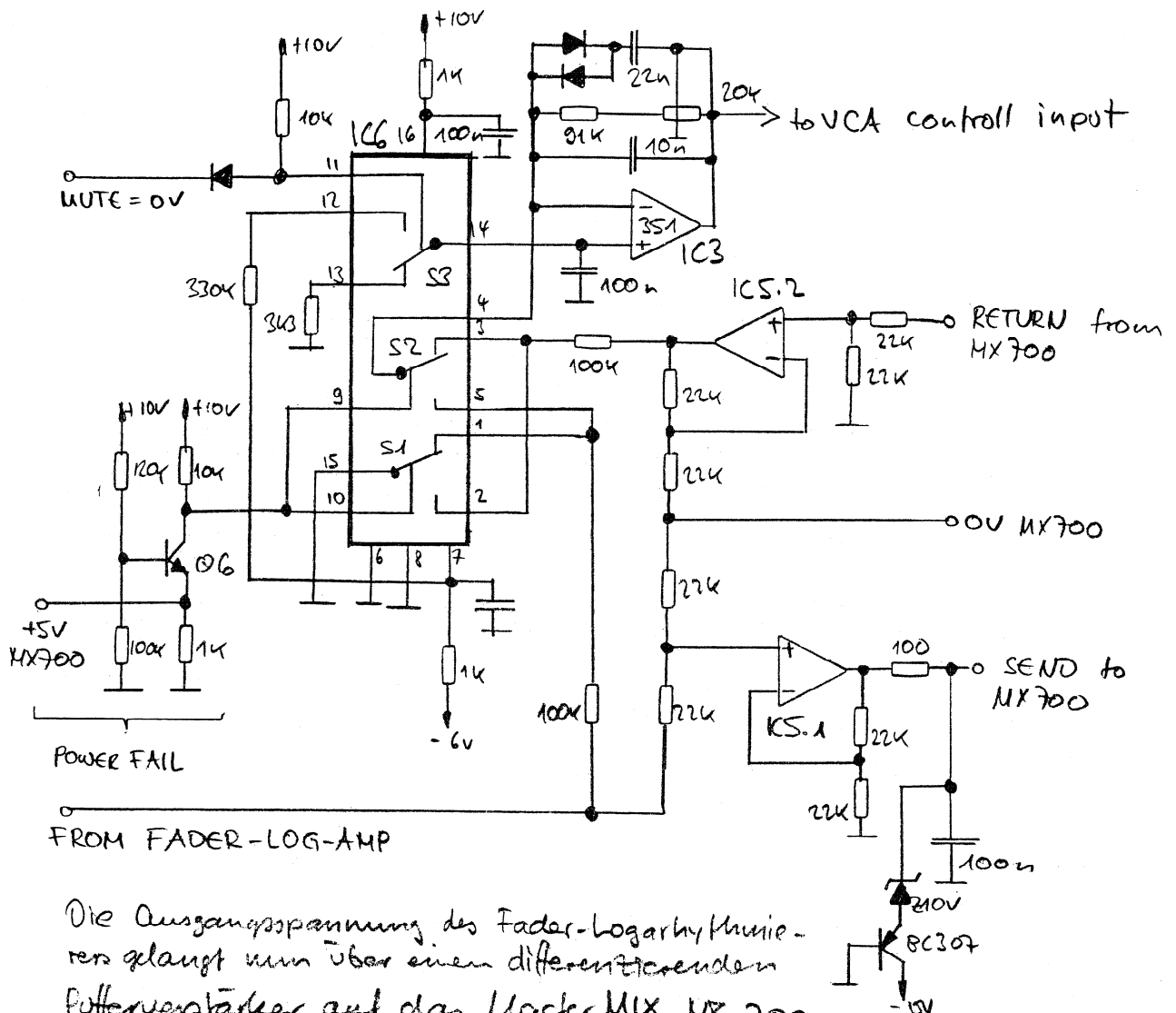

Die Ausgangsspannung des Fader-Logarithmierers gelangt nun über einen differenzierenden Pufferverstärker auf das Master MIX MX-700 Automationsinterface. Um die Steuerspannung von Brummstörungen freizuhalten bringen wir sie mit OPAMP IC5.1 und IC5.2 differenziell zur Masse des Interfaces. Somit findet keine Massenkopplung von Pult und Automationsystem statt.

Das MX700 Interface liefert im eingeschalteten Zustand eine Speisespannung von +5V. Mit Q6 wird nun laufend die Speisespannung überwacht. Wenn diese nun unter 4V sinkt, leitet Q6 und schaltet über Pin 9 und 10 von IC6 die Schalter S1 und S2 um. Dies bewirkt, dass die Spannung vom RETURN-Eingang mit S1 gegen Masse geleitet und die Fader-Steuerspannung direkt über S2 zum VCA geleitet wird.

S3 des Analogschalters IC6 dient zum Muten. Wenn der Mute-Eingang auf Masse gezogen wird (MUTE = 0V), dann schaltet S3 den nichtinvertierenden Über den 330 Ω -Widerstand auf -6V. Durch diesen Widerstand wird die Anstiegs- und Abfallgeschwindigkeit am +-Eingang von IC3 mit dem 100 nF Kondensator begrenzt. Wenn die Mute-Leitung wieder +10V wird, wird der 100 nF-Kondensator nun über S3 und dem 3,3 k Ω Widerstand entladen. IC3 arbeitet wieder als normaler invertierender Verstärker.

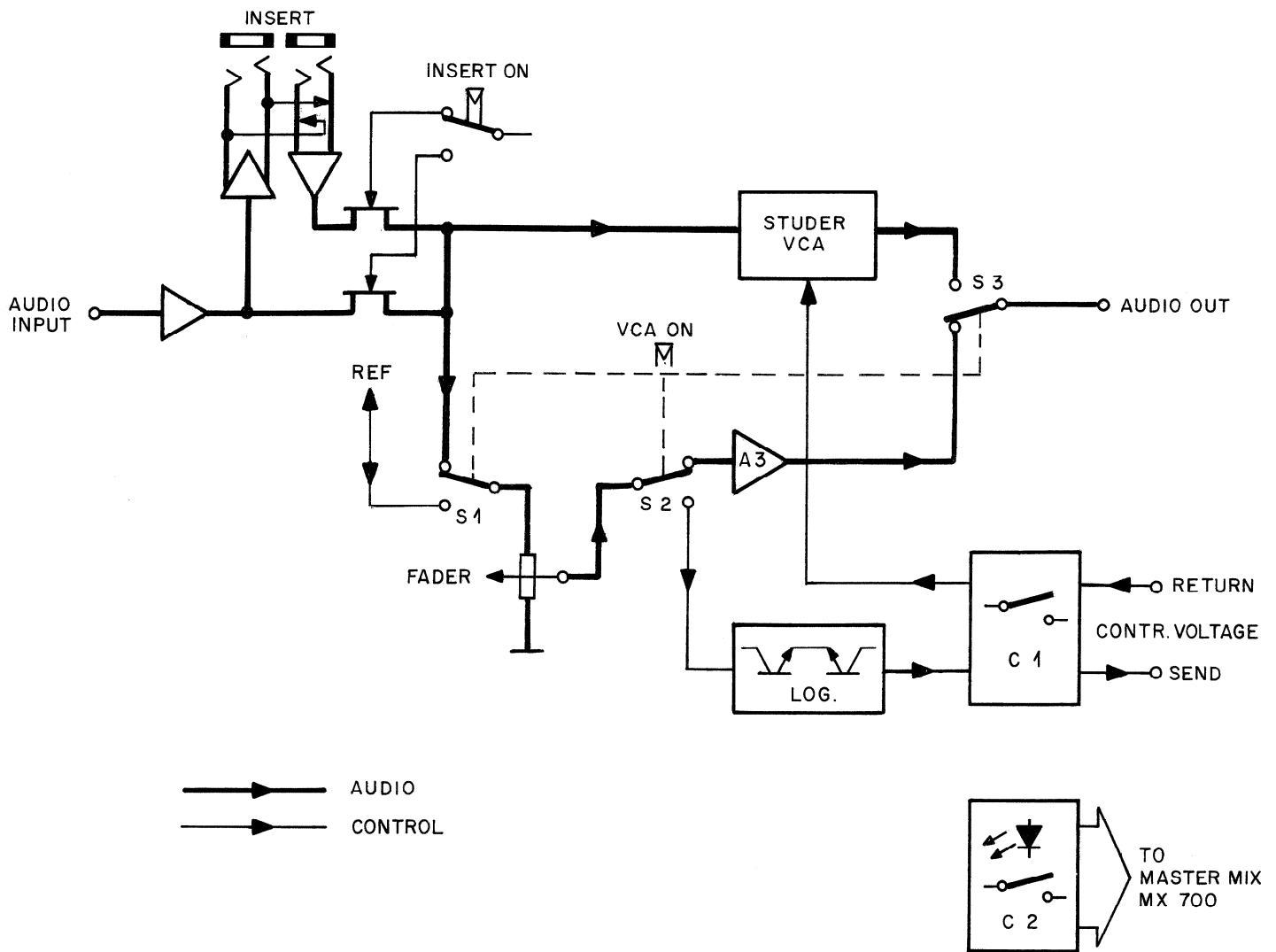

VCA Flachbahnregler (AK)

Der VCA Flachbahnregler 1.911.221 wird zusammen mit dem Audio Kinetics "Mastermix" Automationsystem eingesetzt. Die Kombination von Mastermix MX644 mit einem der ~~dem~~ Mastermix Regie pult Interfaces MMK 732 (bei 32 Eingangskanälen) MMK 742 (42 Eingänge) oder MMK 764 (64 Eingänge) und einer entsprechenden Anzahl von VCA Flachbahnreglern 1.911.221 erlaubt das computerunterstützte Abmischen von ^(SMPTE/EBU) Timecode synchronisierten Aufnahmen und die unbegrenzte Gruppenbildung über das digitale Grouping.

^{und Anzeige}
Bedienungselemente

INSERT IN schaltet den symmetrischen Einschleifpunkt vor dem Flachbahnregler ein.
Bei ausgeschaltetem Einschleifpunkt nicht gedrückter Taste steht das vor dem Flach Regler anliegende Audiosignal ~~als~~ als Direktausgang trotz dem zur Verfügung

VCA IN Bei nicht gedrückter VCA IN-Taste wird der VCA Regler umgangen und das Audio-Signal direkt über den Flachbahnregler geführt.
Bei gedrückter Taste wird das Audio-Signal über den VCA geführt, der Flachbahnregler liefert die Steuerspannung für den VCA
resp ~~oder~~ ~~das~~ Mastermix-System

CH off LED zeigt an, wenn der Kanal ausgeschaltet ist (geschlossener ^{Kanal} Regler, geschlossene Gruppe, Mute signal vom Mastermix)

▽ 0
0
△ 0
drei LED zeigen an, ob die Reglerstellung der vom Mastermix gelieferten Steuerspannung entspricht oder zu klein resp zu gross ist

Group Taste

Taste + LED Erlaubt die Gruppenbildung über das Macromix System

WRITE

Taste + LED Bringt den Kanal von "Read" (übernimmt ^{VCA} Stromspannung vom Automations-System in WRITE (Ebenenspannung des Flachbahnreglers

Einmal

Zweimal

ISOLATE

wird vom A-System übernommen, übernimmt kein ~~normales~~ ^{Exb} +

Durch Drücken übernimmt zwangsweise

Taste + LED. Durch Drücken dieser Taste kann die Flachbahnreglereinheit vom Automations-System abgetrennt werden.

Regeländerungen am Regler wirken sich nicht mehr auf das ~~Macromix System~~ aus der Computer aus

UPDATE

Taste + LED Erlaubt das übernehmen der zum normalen Faderwert Offset

Make write ~~immer~~ im write mode System übernimmt

Make

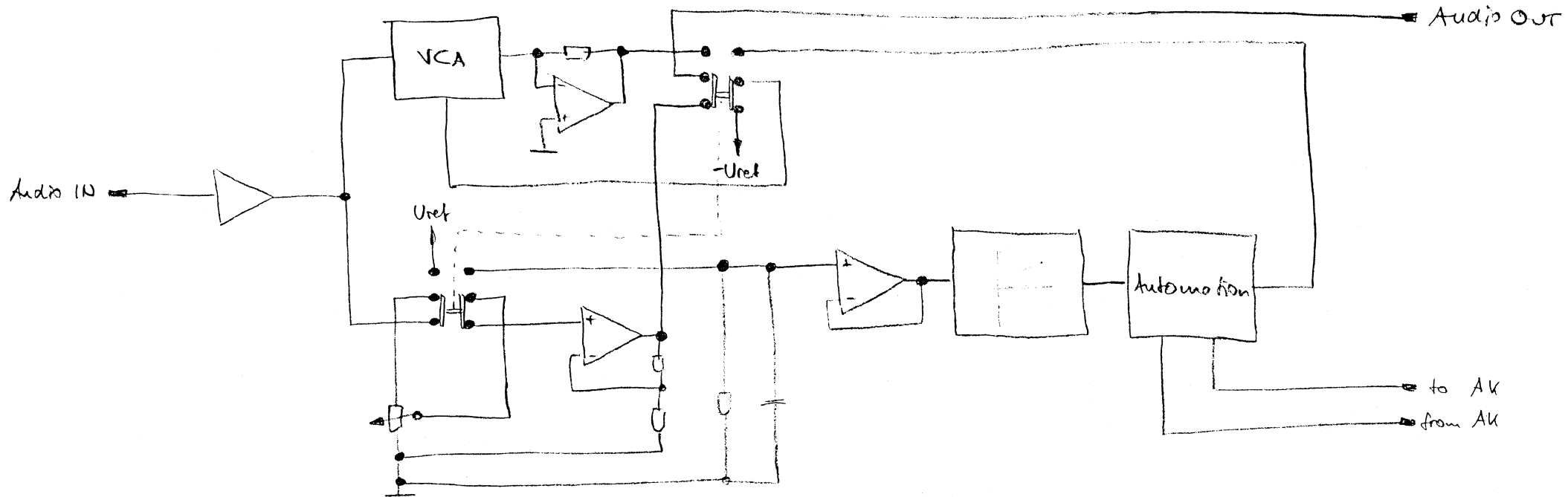

Block-Schema

VCA-Fader AK

S. aus. ~~8~~ mm

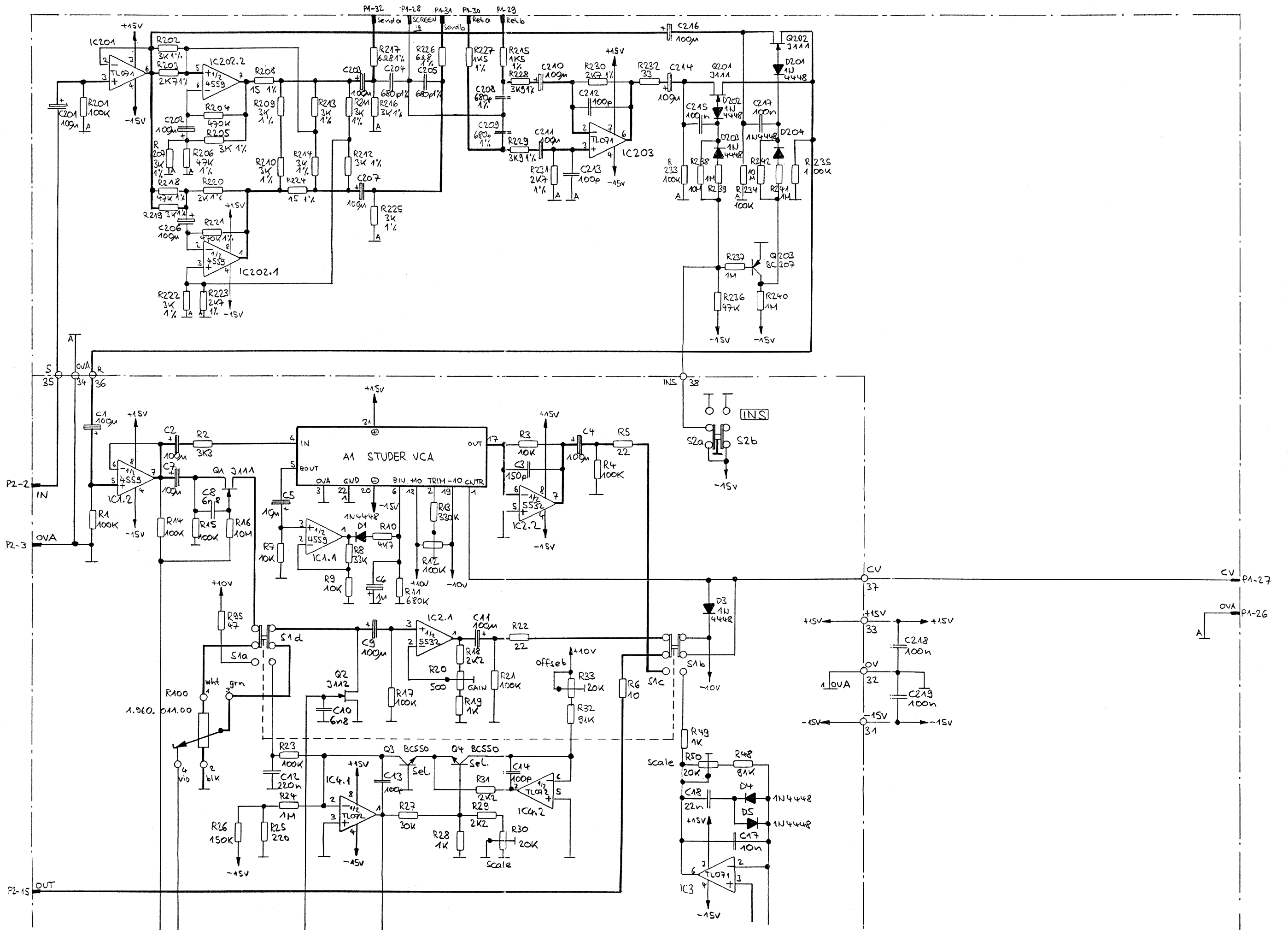

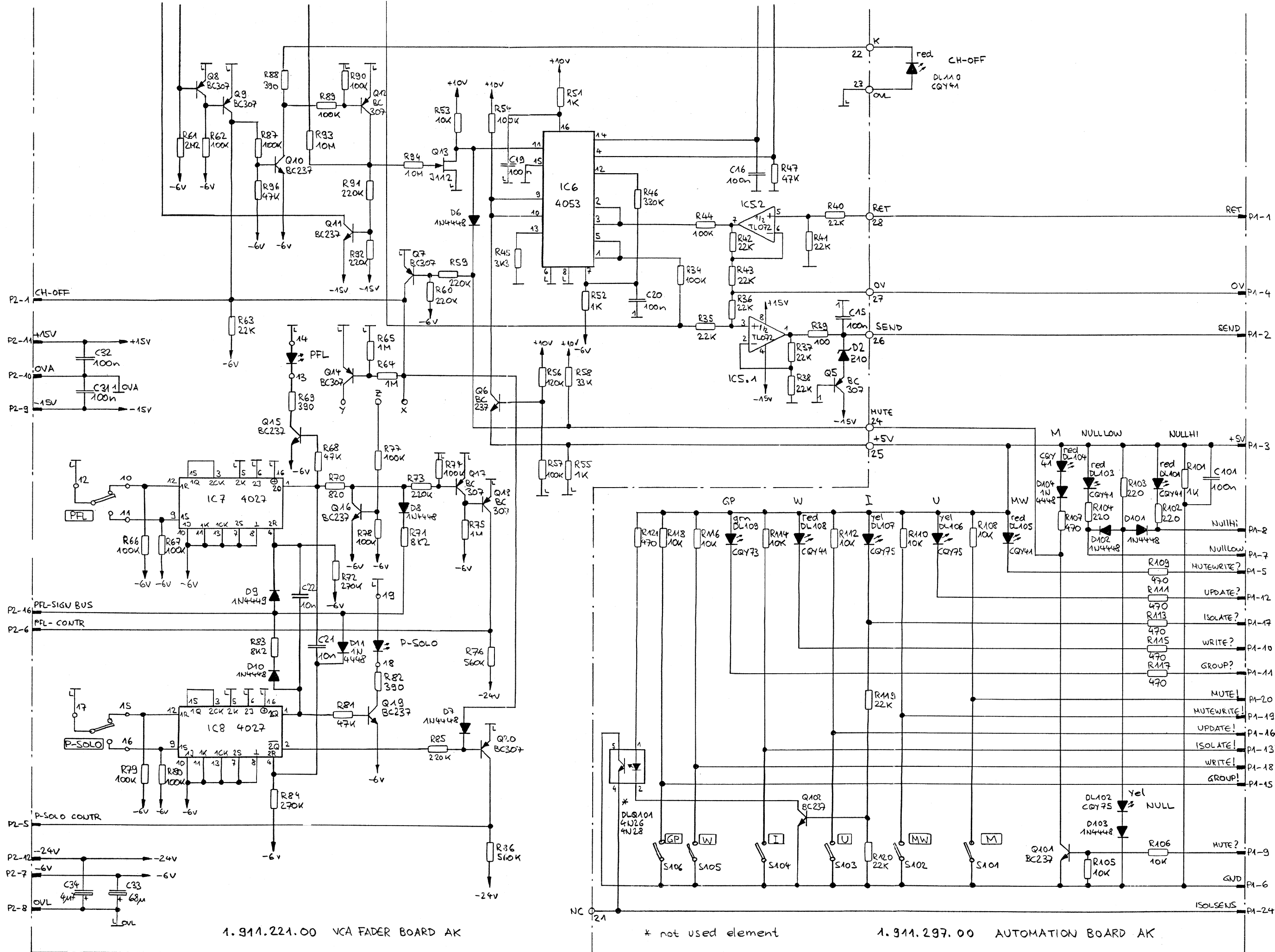

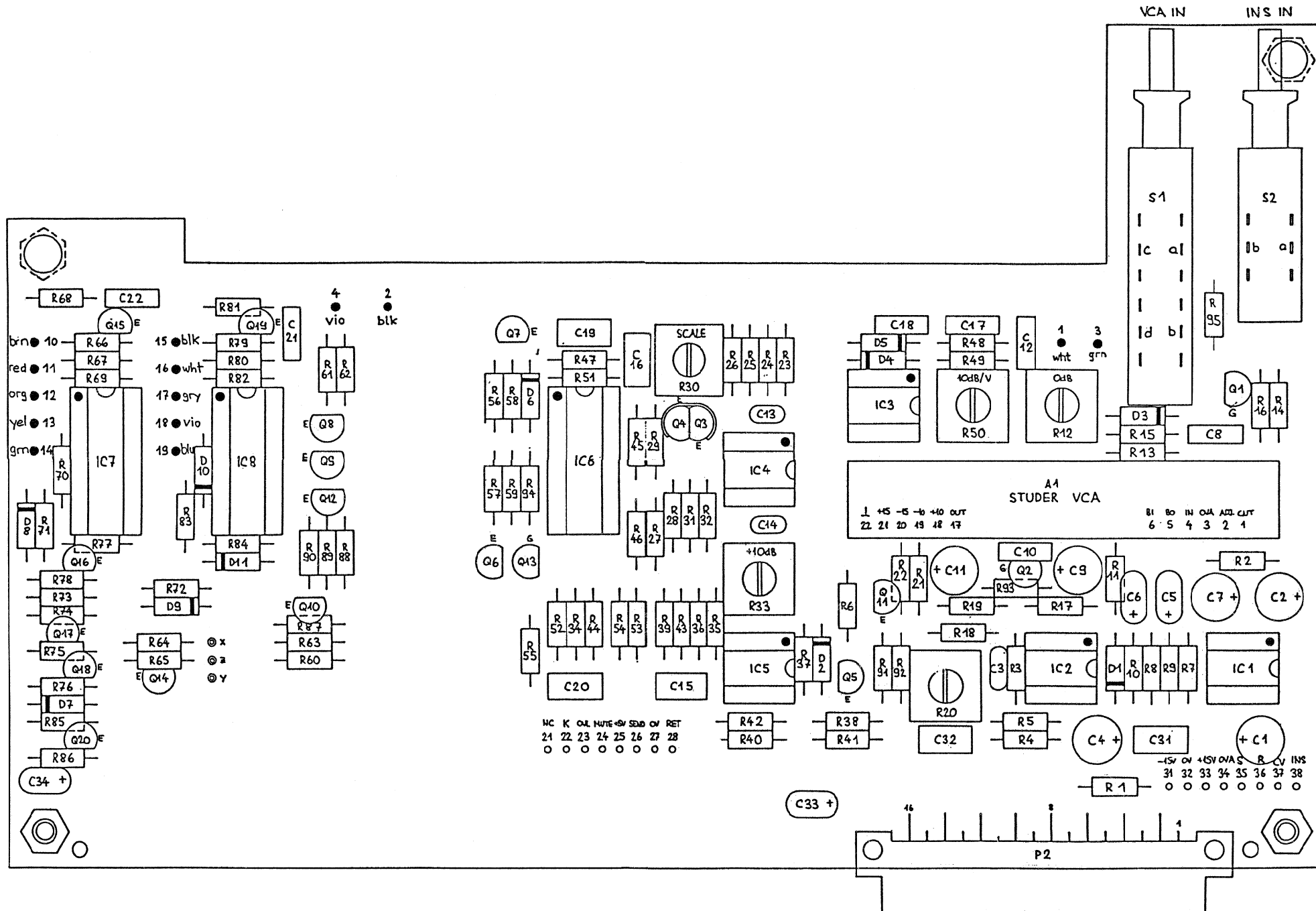

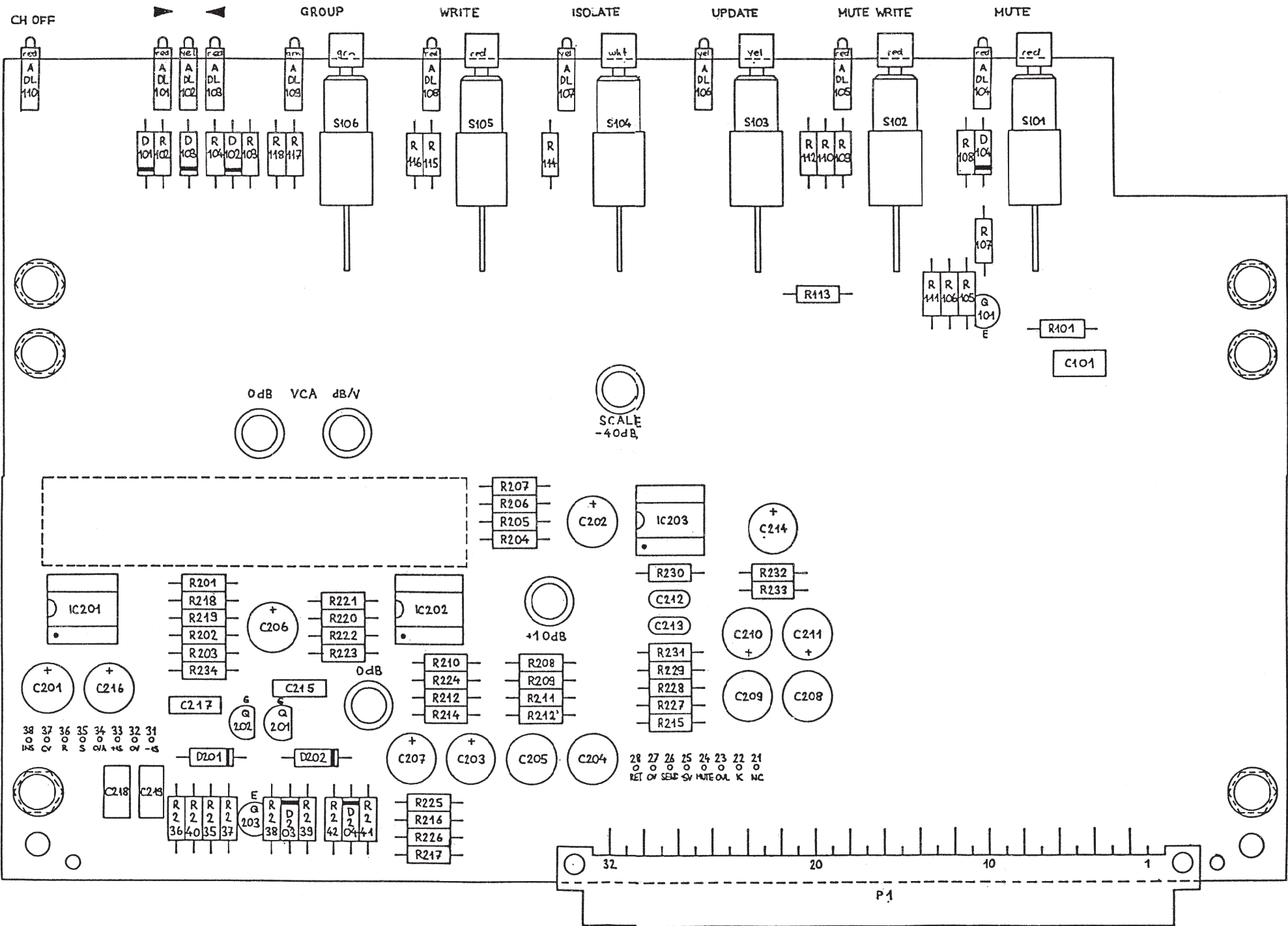

KAPITEL 5: Einschub-Module der Eingangssektion 1.912. ...

INHALT

1.*	Eingangseinheiten Mono 'A'	1.912.220... 226
2.*	Eingangseinheiten Stereo und Hochpegel 'A'	1.912.240../250..
3.*	Eingangseinheiten Mono / Stereo Version 'B'	1.912.120../141..
4.	Hilfssummeneinheit.....	1.912.310
5.	Studiomonitor- und Kommando-Einheit	1.912.320
6.	Kontrollraum-Monitor.....	1.912.420
7.	Monitoreerweiterung (AUX Monitor)	1.912.460
8.	Summenausgangswahl-Einheit.....	1.912.500
9.	Monitor Mixer / mit EQ.....	1.912.510/511
10.	Compact (Hex) Density Mixer.....	1.912.514

SECTION 5: Plug-in Units of the input section 1.912. ...

CONTENTS

1.*	Input units mono 'A'	1.912.220... 226
2.*	Input units stereo and high level 'A'	1.912.240../250..
3.*	Input units mono / stereo 'B'	1.912.120../141..
4.	AUX master unit.....	1.912.310
5.	Studio monitor and talk back unit	1.912.320
6.	Control room monitor.....	1.912.420
7.	Monitor expansion (AUX Monitor)	1.912.460
8.	Master output selector	1.912.500
9.	Monitor mixer / with EQ.....	1.912.510/511
10.	Compact (Hex) Density Mixer.....	1.912.514

- * Diese Beschreibungen werden kundenspezifisch bestückt.
 * These descriptions are supplied according to the customers requirements.

MONO EINGANGSEINHEIT

Die universelle Mono-Eingangseinheit ist mit vier Eingängen ausgerüstet, welche die Verarbeitung von Mikrofon bis Leitungspegel im Bereich -70 ... + 24 dBu erlauben.

Der Filter - und Equalizerteil bietet mit seinen stetig einstellbaren Höhen- und Tiefensperren und dem parametrischen 4-Band Equalizer beste Voraussetzungen zur Frequenzgang-Korrektur und auch zur Realisierung ausgefallener Klangbilder.

Auf der Ausgangsseite der Einheit stehen vier Hilfskanäle (3 Mono, 1 Stereo), das Vorhören vor dem Flachbahnregler und nach dem Panorama-Potentiometer sowie vier resp. acht Hauptausgänge (1.912.220 / 1.912.222) zu den Summensammelschienen zur Verfügung.

Panorama-Potentiometer, Mutetaste, Usertaste, Phantomschalter und Phasenschalter vervollständigen die Eingangseinheit.

MONO INPUT UNIT

The universal input unit is equipped with four inputs which allow a range between the microphone and the line level of -70...+24 dBu.

The filter and the equalizer with its continually adjustable low and high pass filters and the parametric 4-band equalizer provides assumption for correcting frequency response and realization of special tonal effects.

At the unit's output side there are four auxiliary channels (3 mono, 1 stereo). Pre-fader-listening before the fader and after the panorama potentiometer as well as four respectively eight main outputs (1.912.220/1.912.222) to the master busses are available.

Panorama potentiometer, mute switch, user push button, phantom switch and phase switch complete the input unit.

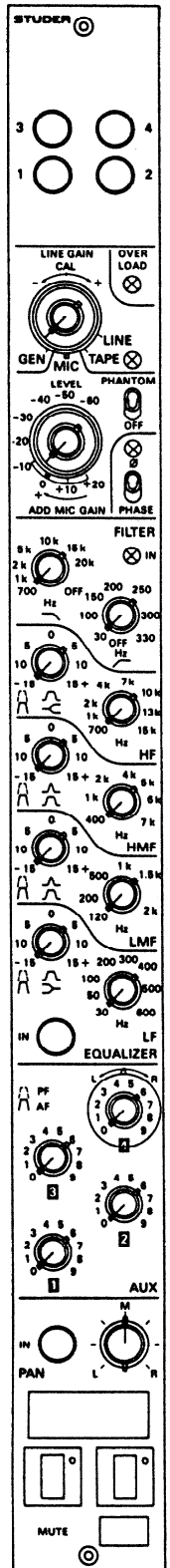

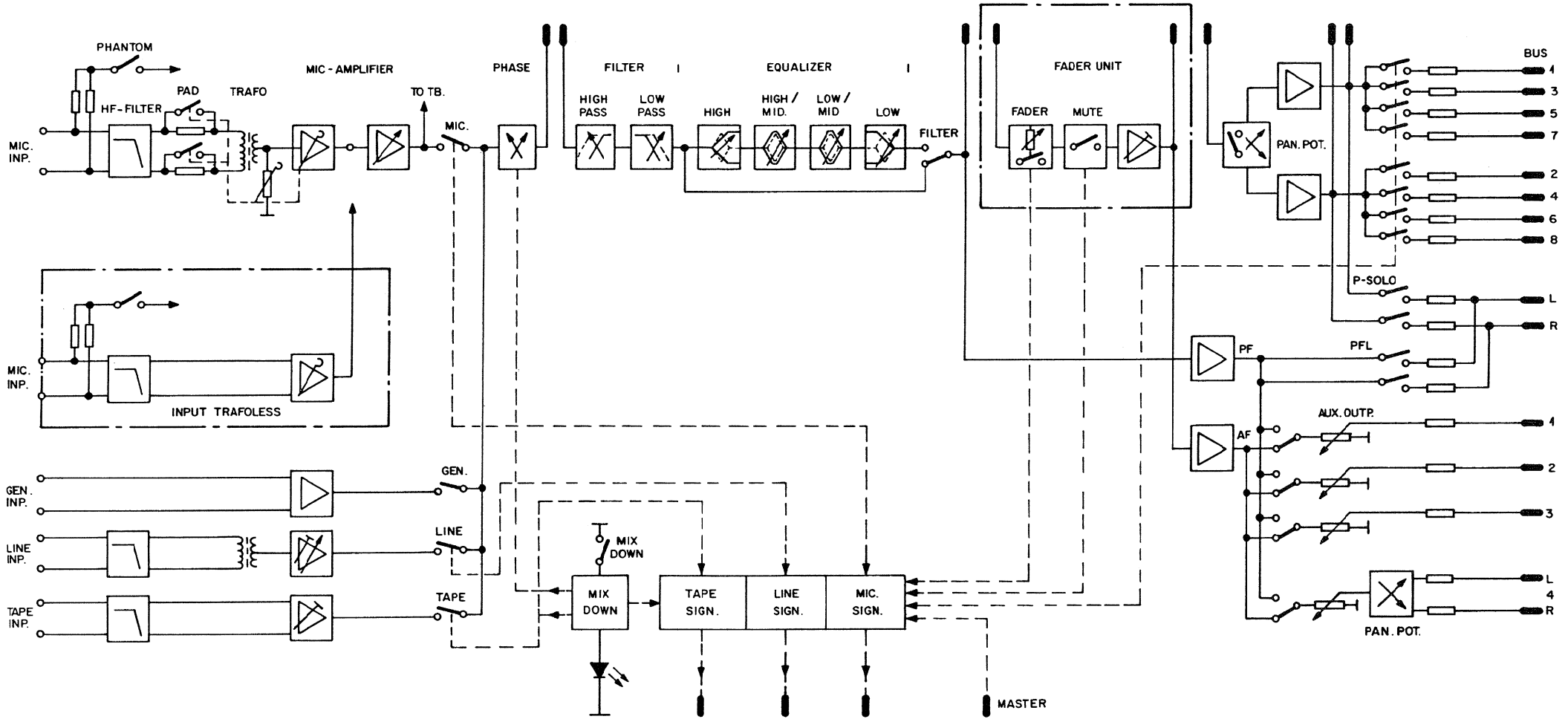

BLOCK DIAGRAM INPUT UNIT MONO

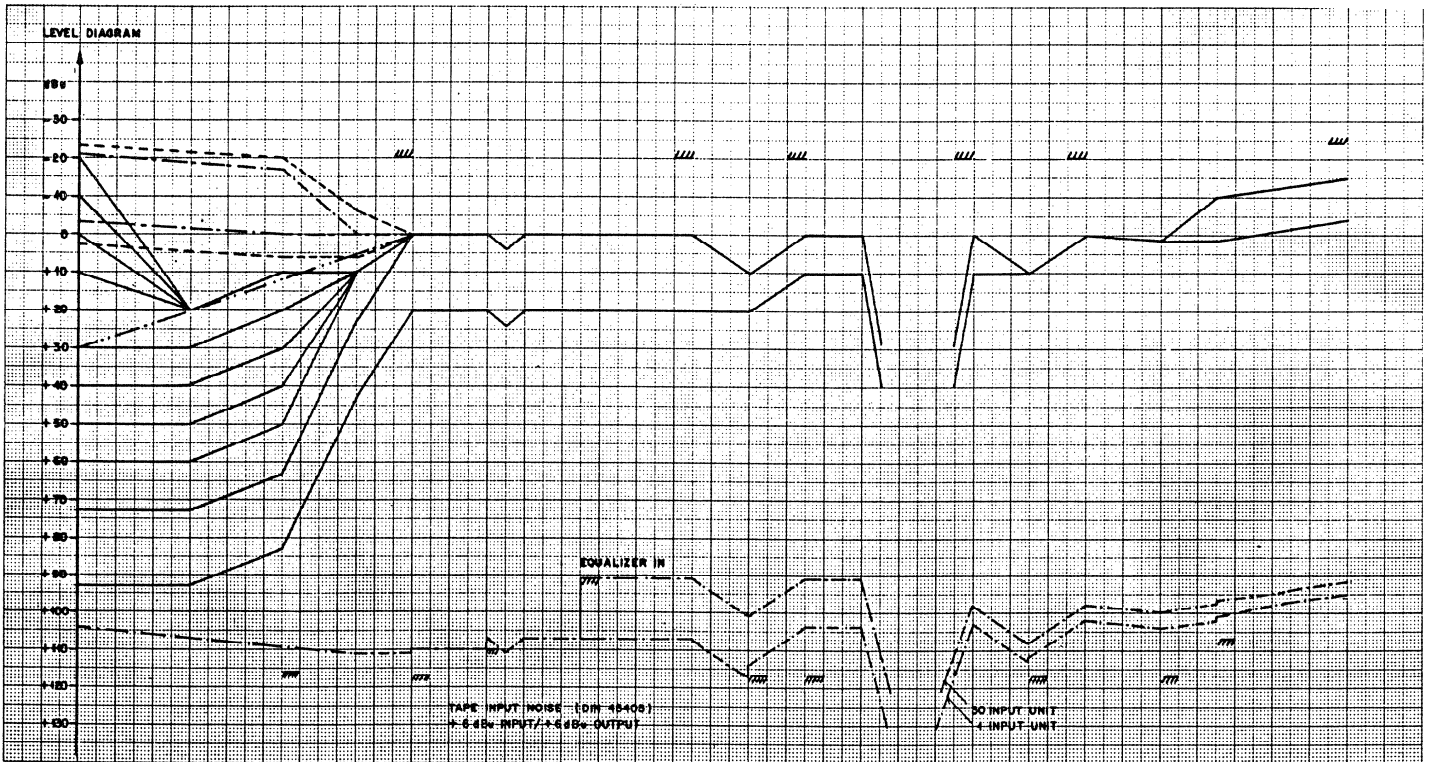
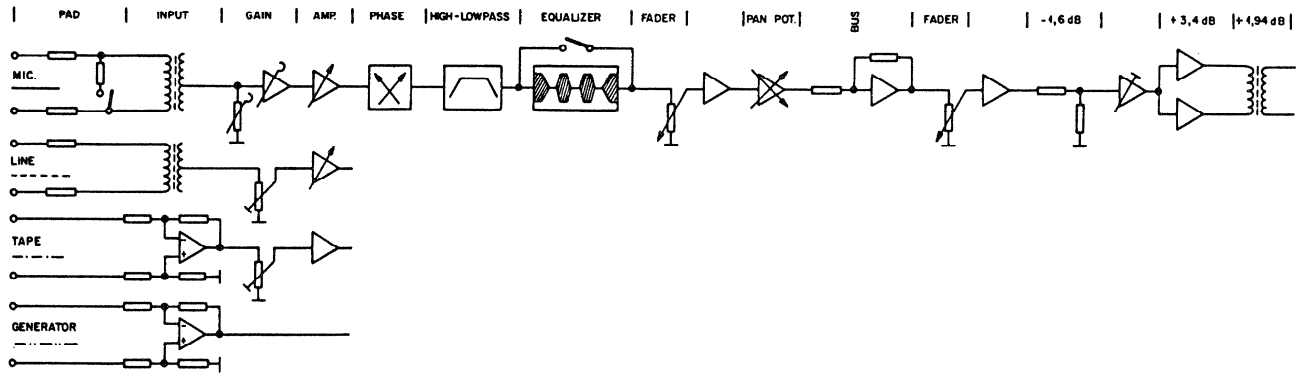

1. EINGANGSTEIL

1. INPUT SECTION

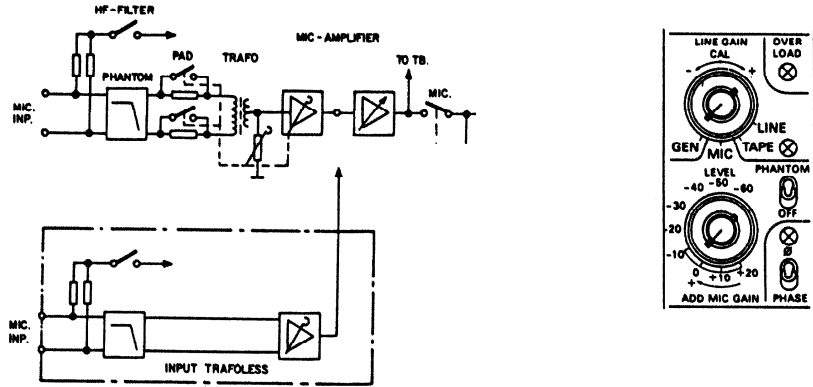

1.1 MIC EINGANG

Universaleingang, Mikrofon bis Leitungspegel, symmetrisch, erdfrei mit Eingangstransformator.

Verstärkung einstellbar mit 9-stelligem Stufenschalter in 10 dB Schritten im Bereich -60... + 20 dBu. Zusätzliche am Potentiometer stetig einstellbare Verstärkung von 0...12 dB.

Kann von extern stumm geschaltet werden (MIC CUT).

Minimaler Eingangspegel bei Normalstellung der Flachbahnregler (0 dB) -72 dBu

Maximaler Eingangspegel +24 dBu

Eingangsimpedanz bei Stellung -20 ... -60 dBu des Pegelschalters >1,5kOhm

Eingangsimpedanz bei Stellung -10 ... + 20 dBu des Empfindlichkeitschalter ≥ 5 kOhm

Eingangssymmetrie (-20 ... -60 dBu) ≥ 60 dB
(+20 ... -20 dBu) ≥ 50 dB

Phantomstromversorgung mit Schalter 48V (auf Wunsch 12V oder 24V)

Fremdspannung bezogen auf den MIC-Eingang bei einem Quellenwiderstand $R_s=200 \text{ Ohm}$ $NF \leq 4 \text{ dB}$

Als Option kann ein symmetrischer, trafoloser Universaleingang eingesetzt werden.

1.1 MIC INPUT

Universal input, microphone to line level, balanced, floating with the input transformer.

The gain can be adjusted with a nine-position selector switch in 10 dB steps in the range of -60...+20 dB. An additional continually adjustable gain of 0...12 dB.

Mute can be operated externally (MIC CUT).

Minimum input level at normal position of the fader (0 dB) -72 dBu

Maximum input level +24 dBu

Input impedance at position -20...-60 dBu of the level switch >1,5 kOhm

Input impedance of the sensitivity switch in position -10...+20 dBu ≥ 5 kOhm

Input symmetry (-20...-60 dBu) ≥ 60 dB
(+20...-20 dBu) ≥ 50 dB

Phantom current supply with switch 48 V (on request 12 V or 24 V)

External voltage referred to the MIC input on a source impedance of $R_s=200 \text{ Ohm}$ $NF \leq 4 \text{ dB}$

A balanced, transformerless universal input can be used as an option.

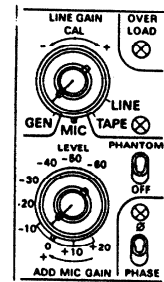
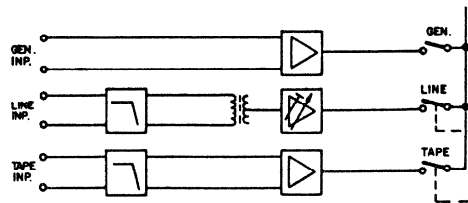

1.2 LINE EINGANG

Hochpegeleingang, symmetrisch, erdfrei, auf Nominalpegel abgeglichen,

an Korrekturpotentiometer mit rastender Mittelstellung um +6dB veränderbar

Nomineller Eingangspegel, einstellbar + 4 ... + 16 dBu

Maximaler Eingangspegel	+ 24 dBu
Eingangsimpedanz	≥ 10kOhm
Eingangssymmetrie	≥ 50 dB a 30 Hz ... 16 kHz
Klirrfaktor	≤ -85dB a 30 Hz ... 16 kHz
Fremdspannungsabstand	≥ 100 dB

1.3 TAPE EINGANG

Trafoloser, symmetrischer Hochpegeleingang auf Nominalpegel abgeglichen. Durch externen MIX-DOWN Befehl mit Vorrang schaltbar. Gleichzeitig wird der Phaseninverter ausgeschaltet.

Nomineller Eingangspegel	+4 ... + 21 dBu
Maximaler Eingangspegel	+ 24 dBu
Eingangsimpedanz, symmetrisch	≥ 10 kOhm
asymmetrisch	≥ 5 kOhm
Eingangs-Symmetrie	≥ 50dB a 30Hz...16 kHz
Klirrfaktor	≤ 85dB a 30Hz...16 kHz
Fremdspannungsabstand	≥ 100 dB

1.4 GEN EINGANG

Tongeneratoreingang symmetrisch, trafolos, wird vom Testgenerator über Sammelschienen gespeist.

Eingangspegel	-30 dBu
---------------	---------

1.5 EINGANGSUMSCHALTUNG

Der Eingangswahlschalter steuert über Gleichspannungssignale Feldeffekttransistoren, welche ihrerseits das Niederfrequenzsignal kontaktlos durchschalten.

Zusätzliche Steuereingänge (6V Gleichspannung) erlauben es

- den Mikrofoneingang ferngesteuert zu unterbrechen (Räuspertaste/Mute Schaltung)
- den TAPE-Eingang mit Priorität durchzuschalten (MIX DOWN).

1.2 LINE INPUT

High level input, balanced and floating, aligned to nominal level

at correction potentiometer with framed medium position changeable by ±6 dB

Nominal input level, adjustable +4...+16 dBu

Maximum input level	+ 24 dBu
Input impedance	≥ 10 kOhm
Input symmetry	50 dB @ 30 Hz ... 16 kHz
Distortion	-85 dB @ 30 Hz ... 16 kHz
Signal to noise ratio	≥ 100 dB

1.3. TAPE INPUT

Transformerless, balanced high level input aligned to nominal level. Switchable through external MIX-DOWN order with priority. Simultaneously the phase inverter in mute position.

Nominal input level	+4 ... +21 dBu
Maximum input level	+24 dBu
Input impedance, balanced	≥ 10 kOhm
unbalanced	≥ 5 kOhm
Input symmetry	≥ 50 dB @ 30 Hz ... 16 kHz
Distortion	≤ 85 dB @ 30 Hz ... 16 kHz
Signal to noise ratio	≥ 100 dB

1.4 GEN INPUT

Audio generator input balanced, transformerless and the test generator gets fed by busses.

Input level	-30 dBu
-------------	---------

1.5 INPUT SWITCHING

The input selector switch controls field effect transistors with current voltage signals which themselves contactlessly connect the low frequency signal through.

Additional control inputs (6 V direct current voltage) allow

- to interrupt the microphone input remote controlled (cough key/mute mounting)
- to connect the TAPE input through with priority (MIX DOWN).

1.6 PHASENSCHALTER Ø

Der Kippschalter Ø mit LED Anzeige steuert über Feldeffekttransistoren einen Operationsverstärker von normaler in invertierende Phasenlage um. Die Phasenlage aller Eingangssignale wird dadurch gedreht.

MIX DOWN Betrieb stellt den nicht invertierenden Betrieb wieder her.

1.6 PHASE SWITCH Ø

The toggle switch Ø with LED indication reverses an operational amplifier from normal to inverted phase-relationship by field effect transistors. The phase-relationship of all input signals gets turned by that.

The MIX DOWN operation reestablishes the not inverted activity.

2. FILTER

2. FILTER

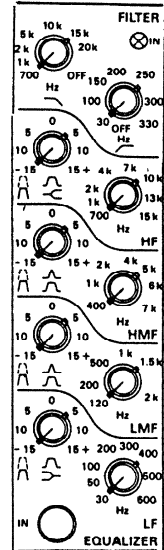
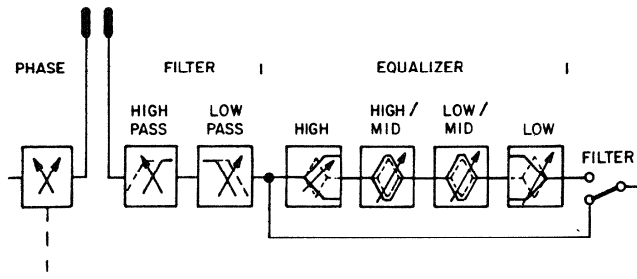

2.1 TIEFENSPERRE (HIGH-PASS-FILTER)

Hochpassfilter mit Butterworth-Charakteristik und 12 dB/Oktave Steilheit. Die Eckfrequenz ist mit Potentiometer im Bereich 30 ... 330 Hz stetig einstellbar. In der Stellung OFF wird die Grenzfrequenz auf ca. 5 Hz gelegt.

2.1 HIGH-PASS FILTER

High-pass filter with Butterworth characteristic and 12 dB/octave slope. Frequency range continuously variable in the range 30 ... 330 Hz. In position OFF, the cutoff frequency is put at about 5 Hz.

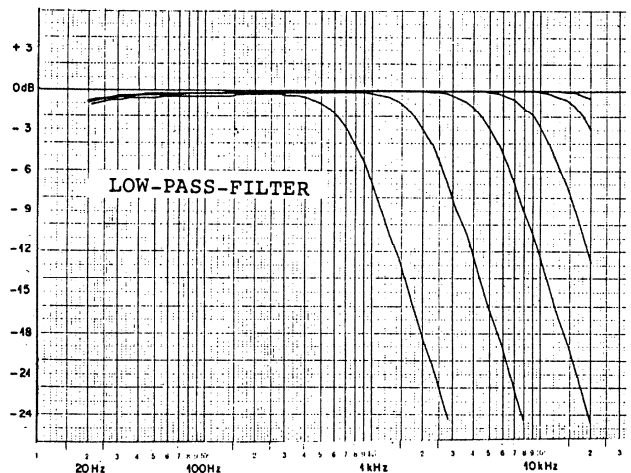
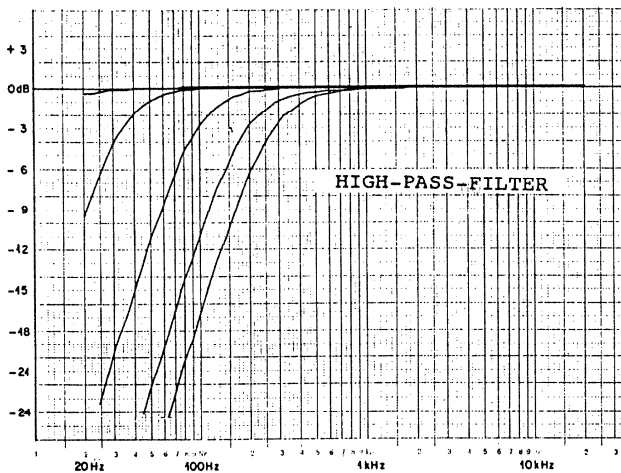

2.2 HOEHENSPERRE (LOW-PASS-FILTER)

Tiefpass-Filter mit Butterworth-Charakteristik und 12 dB/Oktave Steilheit. Die Eckfrequenz ist mit Potentiometer im Bereich 700 ... 22 kHz stetig einstellbar.

In der Stellung OFF wird die Grenzfrequenz auf ca. 30 kHz gelegt.

2.2 LOW-PASS FILTER

Low-pass filter with Butterworth characteristic and 12 dB/octave slope. Frequency range continuously variable in the range 700 ... 22 kHz.

In position OFF, the cutoff frequency is put at about 30 kHz.

2.3 LED-ANZEIGE

Die den beiden Filtern zugeordnete LED-Anzeige leuchtet, sobald eines oder beide Filter eingeschaltet sind.

2.3 LED INDICATION

The LED which is assigned to both of the filters indicates one or both filters switched on.

3. ENTZERRER

3. EQUALIZER

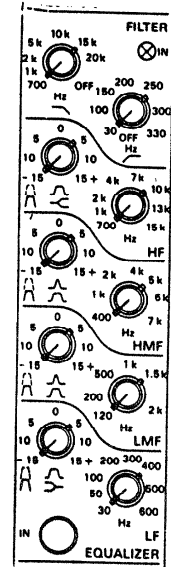
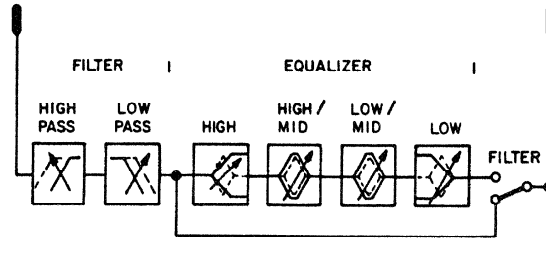

Der Entzerrerteil umfasst vier parametrische Filter, deren Mittenfrequenz und deren Anhebung resp. Absenkung stufenlos eingestellt werden können.

The four-band equalizer has continuously, variable frequency controls, cut and boost controls are also continuously variable and have a range of ± 15 dB.

3.1 HF-ENTZERRER

3.1 HF EQUALIZER

Höhenfilter 700 Hz ... 15 kHz ± 15 dB

High-pass Equalizer 700 Hz ... 15 kHz ± 15 dB

Charakteristik von Glockenkurve auf Fächerentzerrer umschaltbar

Characteristic switchable from "peaking" to "shelving"

Güte der Glockenkurve ≈ 1

Q factor of peaking curve ≈ 1

3.2 HMF/LMF-ENTZERRER

3.2 HMF/LMF EQUALIZER

Zwei parametrische Filter mit umschaltbarer Güte. Einstellbare Mittenfrequenz 400 Hz...7kHz resp. 120 Hz...2kHz.

Two parametric equalizer with switchable Q factor. Adjustable centre frequency 400 Hz ... 7 kHz respectively 120 Hz ... 2 kHz.

Anhebung / Absenkung ± 15 dB

Boost / cut ± 15 dB

Güte: 1,1 / 3

Q factor: 1,1 / 3

3.3 LF-ENTZERRER

3.3 LF EQUALIZER

Tiefenfilter 30 ... 600 Hz, ± 15 dB

Low-pass equalizer 30 ... 600 Hz ± 15 dB

umschaltbar von Glockenkurve auf Fächerentzerrer

switchable from "peaking" to "shelving"

Güte der Glockenkurve ≈ 1

Q factor of peaking curve ≈ 1

3.4 ENTZERRER TASTE

3.4 EQUALIZER BUTTON

Taste zur Ueberbrückung des ganzen Entzerrerteils LF / LMF / HMF / HF

Push button for bridging the whole equalizer LF / LMF / HMF / HF

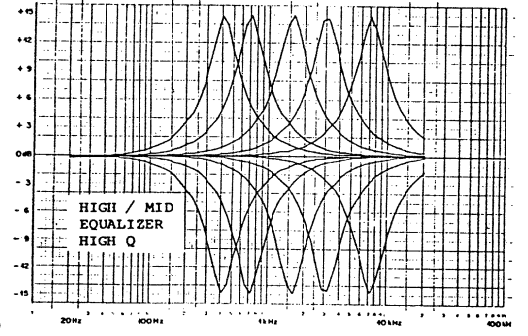
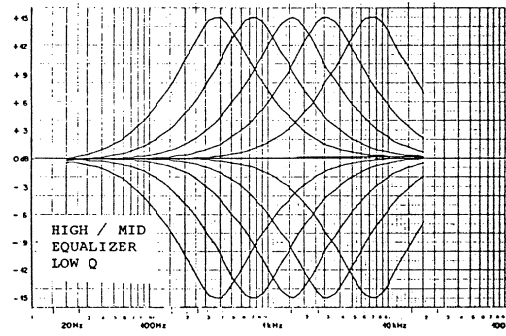
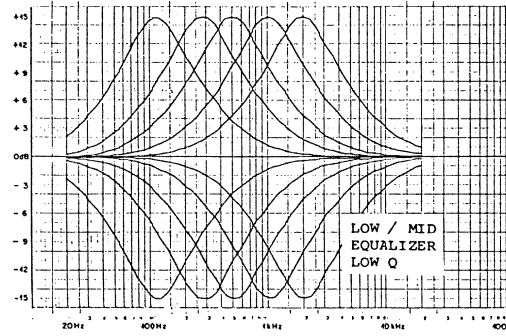
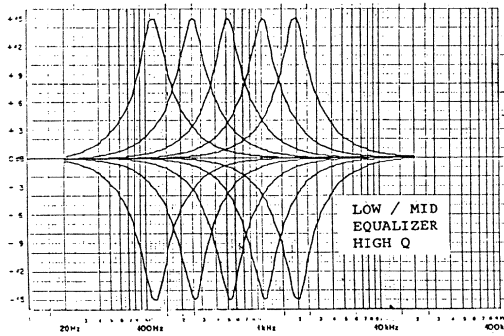
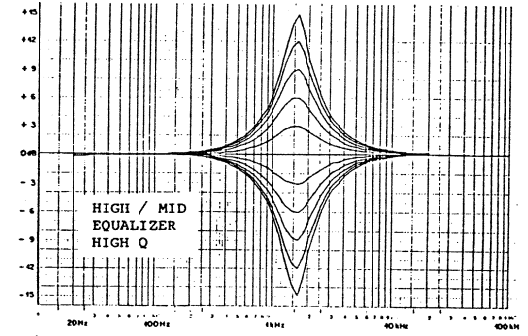
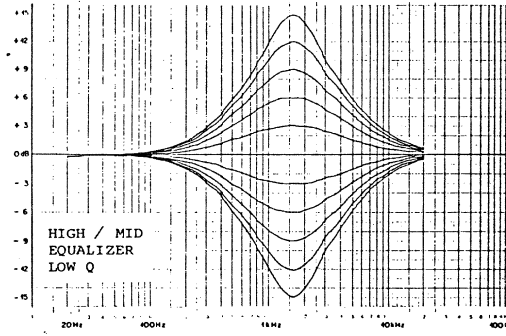
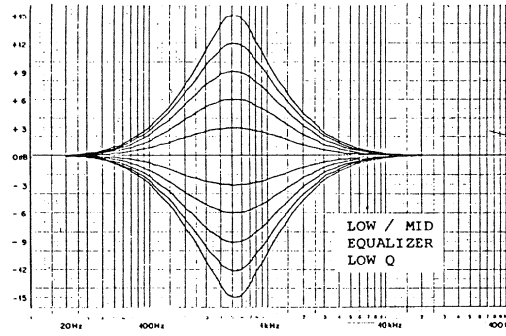
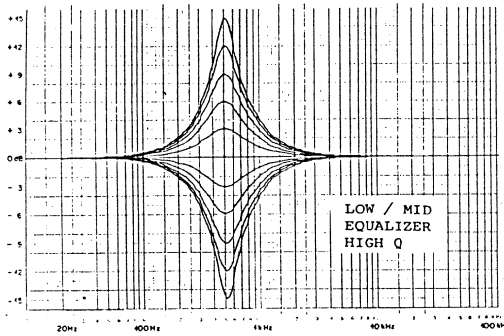
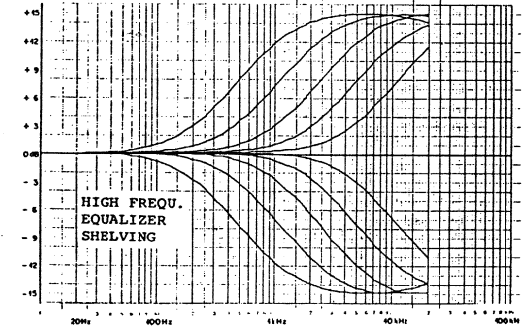
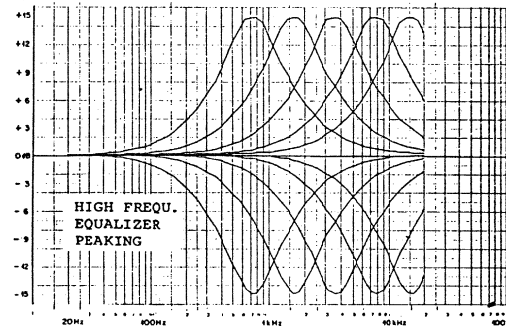
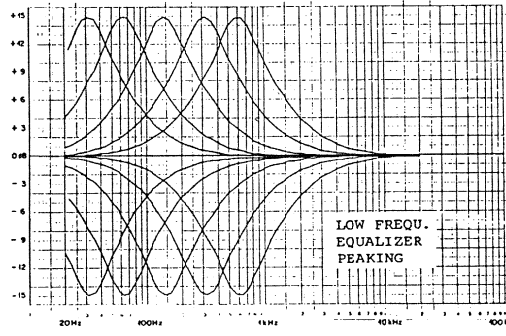
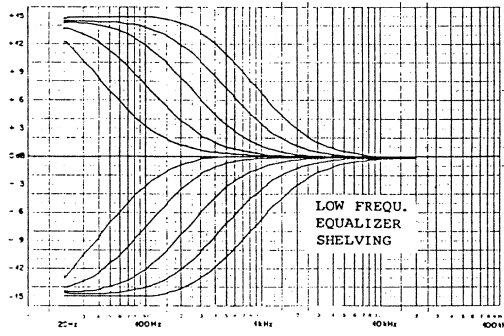
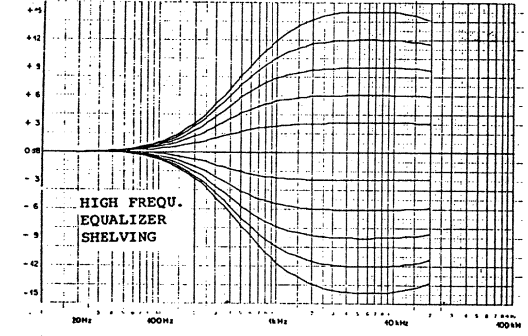
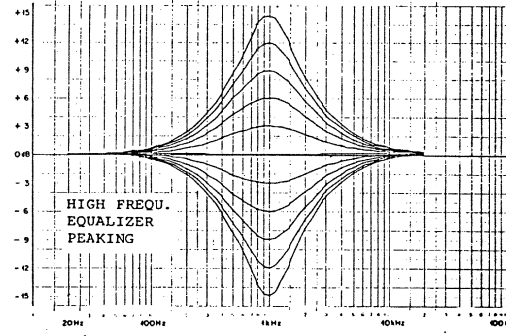
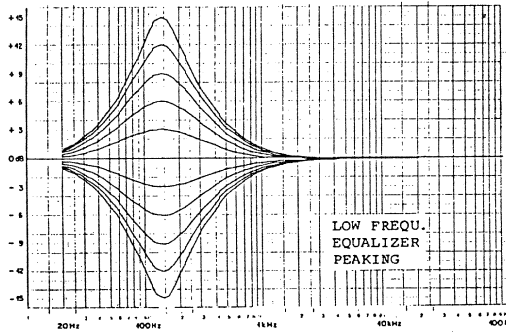
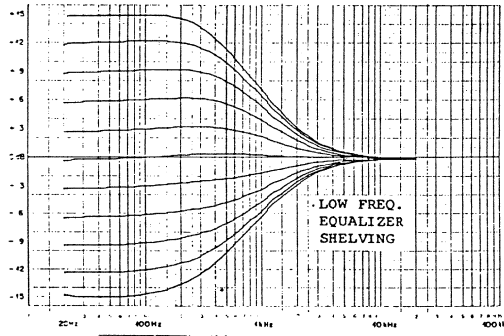

4. HILFSAUSGAENGE AUX 1 ... AUX 4

Die vier getrennt regelbaren Hilfsausgänge werden zur Hallmischung, als Playback-, Foldback- oder Mithörkanal eingesetzt. Das Signal lässt sich über die mit den Potentiometern gekoppelten Zug-Druckschalter wie folgt wählen:

- gezogen-PF Das Signal wird vor dem Flachbahnregler abgegriffen
- gedrückt-AF Das Signal wird nach dem Flachbahnregler abgegriffen.

AUX 1 ... 3 sind Monoausgänge, der Stereohilfsausgang AUX 4 ist zusätzlich mit einem Panorama-Potentiometer ausgerüstet.

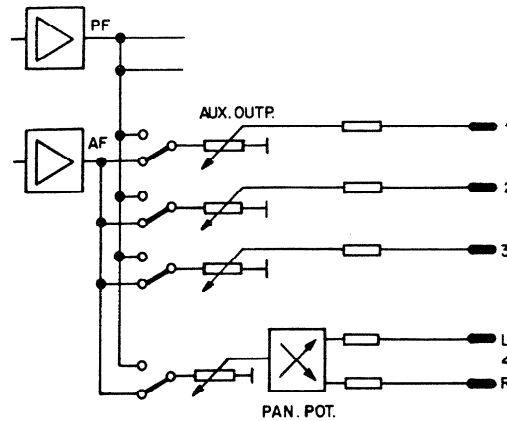

4. AUXILIARY OUTPUTS AUX 1 ... AUX 4

The four separately adjustable auxiliary outputs are used for sound blending, as play-back-, foldback- or monitoring channel. The signal can be selected via the pull-push button which is connected with the potentiometer:

- pulled-PF The signal gets tapped off before the waferswitch
- crushed-AF The signal gets tapped off after the waferswitch.

AUX 1 ... 3 are mono outputs, the stereo auxiliary output AUX 4 is additionally equipped with a panorama potentiometer.

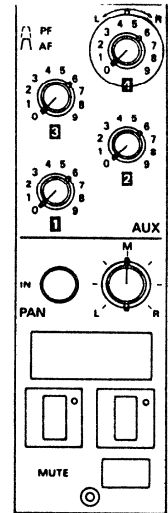

5. MUTE- und USER-TASTEN

MUTE:

Impulstaste mit elektronischer Umschaltung zum Stummschalten des Eingangskanals. Statusanzeige mit LED.

USER:

Umschalten mit LED-Anzeige für Zusatzfunktionen die vom Anwender gewünscht werden, z.B. Aufheben des MIX-DOWN Zustandes, Fernstart einer Quelle, Signalisation usw. Das darunter liegende Einlageplättchen kann mit der Funktionsbezeichnung graviert werden.

5. MUTE- and USER-PUSH BUTTON

MUTE:

Impulse push button with electronical switch for muting of the input channel. State indicator with LED.

USER:

Switching with LED indicator for additional functions which are requested by the user, for example cancelling of the MIX DOWN condition, remote starting of a source, signalization etc. The small insertion plate which is located below can be engraved with the description of the function.

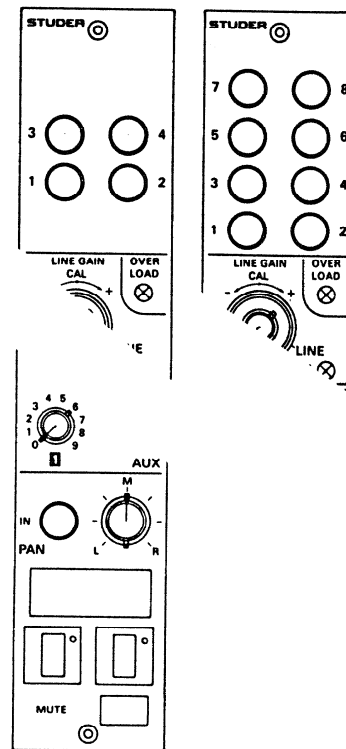
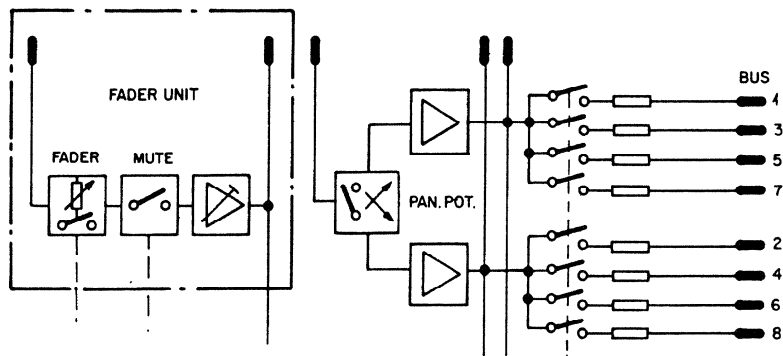

6. PAN.POT.

Ein Drucktastenschalter erlaubt das Zuschalten eines Panorama-Potentiometers in den Hauptausgang.

6. PAN.POT.

A push button switch allows the connection of a panorama potentiometer into the main output.

7. SUMMEN ANWAHL

Vier Tasten bei der Eingangseinheit 1.912.220 und acht Tasten bei der Einheit 1.912.222 dienen zur Anwahl der 4 resp. 8 Hauptsammel-schienen.

Bei 16- und 24-Kanal Mischpulten wird das Regiepult durch einen 8 resp. 16-teiligen Tastensatz im Schrägteil ergänzt.

Die Modulationsdurchschaltung erfolgt über Feldeffekt-Transistoren.

7. MASTER SELECTION

Four push buttons at the input unit 1.912.220 and eight push buttons at the unit 1.912.222 serve for the selection of the 4 respectively 8 main bus bars.

The mixing desk of 16- and 24-channel mixing consoles gets completed by an eight respectively sixteen parts key set in the sloping part.

The modulation interconnection takes place over field effect transistors.

8. OVERLOAD-SIGNALE

Der Audiopegel wird an drei Stellen der Eingangseinheit überwacht. Sobald der Pegel am Ausgang des Entzerrers oder nach dem Flachbahnregler einen Pegel von ca. + 17 dBu überschreitet (ca. 3 dB unterhalb der Uebersteuerungsgrenze) leuchtet die OVERLOAD LED auf.

8. OVERLOAD SIGNALS

The audio level gets controlled on three positions of the input unit. As soon as the level at the output of the equalizer or after the fader exceeds a level of about +17 dBu (about 3 dB below the overmodulation limit), the OVERLOAD LED lights up.

9. FLACHBAHNREGLER 1.911.110

9.1 REGLER

Flachbahnregler mit conductiv-Plastik-Bahn.

9.2 PFL TASTE

Vorhörtaste (Impulstaste mit elektronischer Umschaltung und LED-Anzeige) schaltet das Audiosignal vor dem Flachbahnregler auf die PFL-Sammelschiene.

Durch Einlöten einer Brücke auf der gedruckten Leiterplatte kann das PFL Signal beim Öffnen des Reglers automatisch unterbrochen werden.

9.3 P. SOLO TASTE

Abhörtaste (Impulstaste mit elektronischer Umschaltung und LED-Anzeige) schaltet das Audiosignal nach dem Panorama-Potentiometer auf die Stereo-Vorhörsammelschiene.

9.4 SIGNALSTROMKREIS

Der Flachbahnregler ist mit einem Schalter versehen, der beim Öffnen des Reglers ein Signal an die logische Schaltung weitergibt. Abhängig vom MUTE-Schalter, der Stellung des Eingangswählers, der Summenanwahltasten und der Stellung des Summenreglers, eventuell auch der MIC-CUT Information, entsteht am Ausgang je ein getrenntes Faderstart-Signal für die Eingänge MIC, LINE und TAPE.

9. FADER 1.911.110

9.1 CONTROL

Fader with conductive plastic resistor layer.

9.2 PFL PUSH BUTTON

Pre-fader listening (pulse push button with electronical switching and LED indication) switches the audio signal before the fader to the PFL bus bar.

By soldering a bridge on the printed circuit board, the PFL signal can automatically be interrupted while opening the control.

9.3 P. SOLO PUSH BUTTON

The monitoring key (pulse push button with electronical switching and LED indication) switches the audio signal after the panorama potentiometer to the stereo pre-fader listening bus bar.

9.4 SIGNALLING CIRCUIT

The fader is equipped with a switch which passes a signal on to the logical connection while opening the control. Depending on the MUTE switch, the position of the input selector, the master bus buttons and the position of the master control maybe even of the MIC-CUT information, at the output is each a seperated fader start signal formed for the inputs MIC, LINE and TAPE.

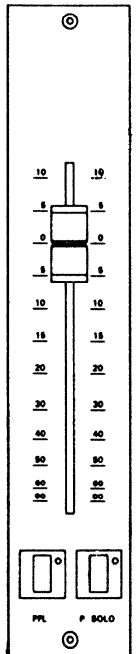

INPUT AMPLIFIERS

SOURCE SELECTOR

PHASE REVERSE

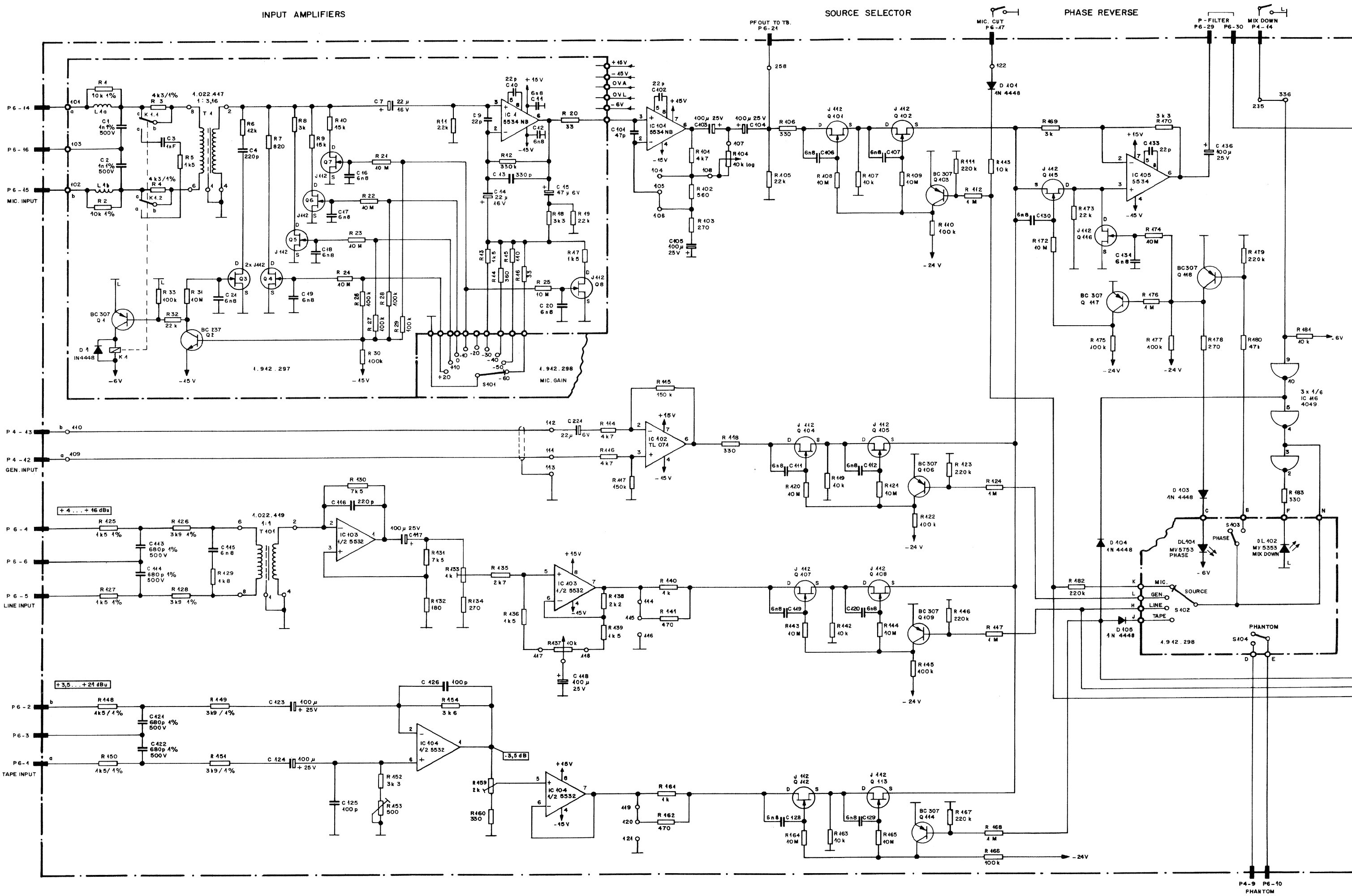

HIGHPASS
30 Hz ... 330 Hz

LOWPASS
700 Hz ... 20 kHz

HIGH EQUALIZER (HF)
750 Hz ... 45 kHz

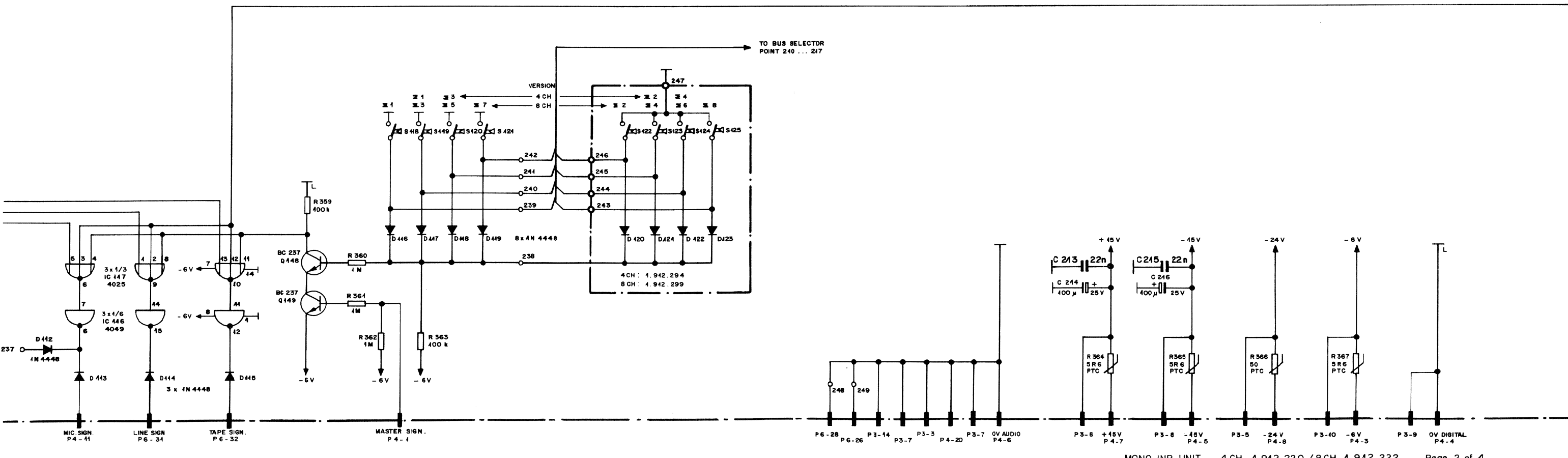
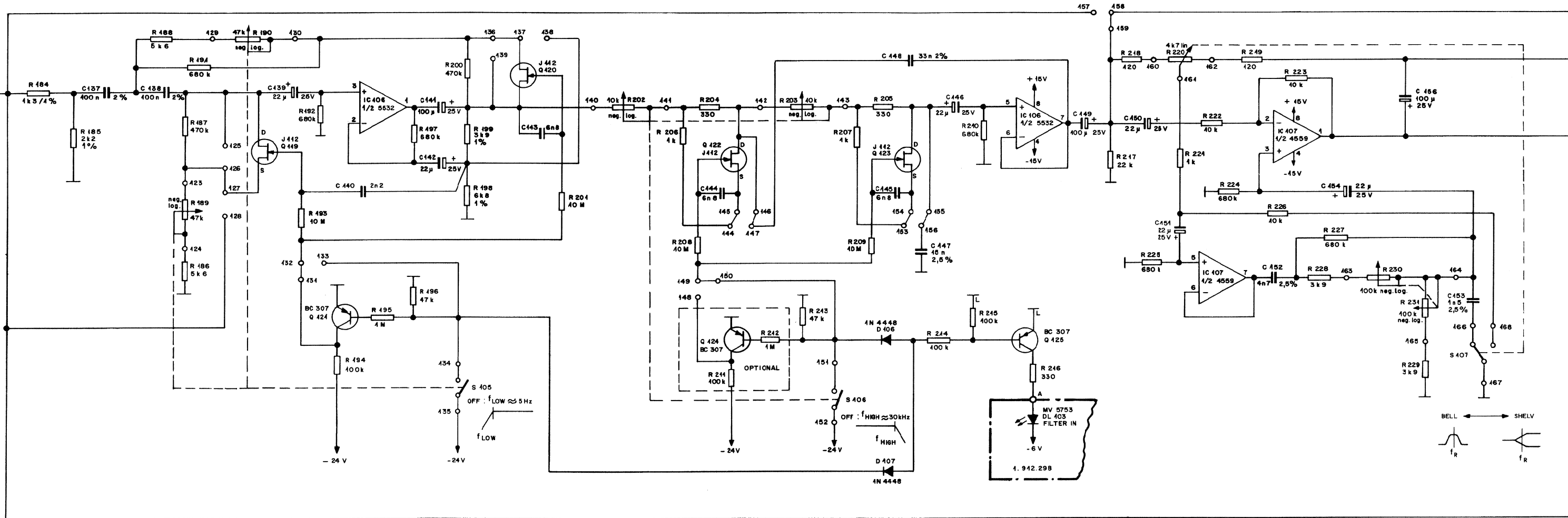

HIGH PARAMETRIC EQUALIZER (HMF)
350 Hz ... 7 kHz

LOW PARAMETRIC EQUALIZER (LMF)
100 Hz ... 2 kHz

LOW EQUALIZER (LF)
30 Hz ... 600 Hz

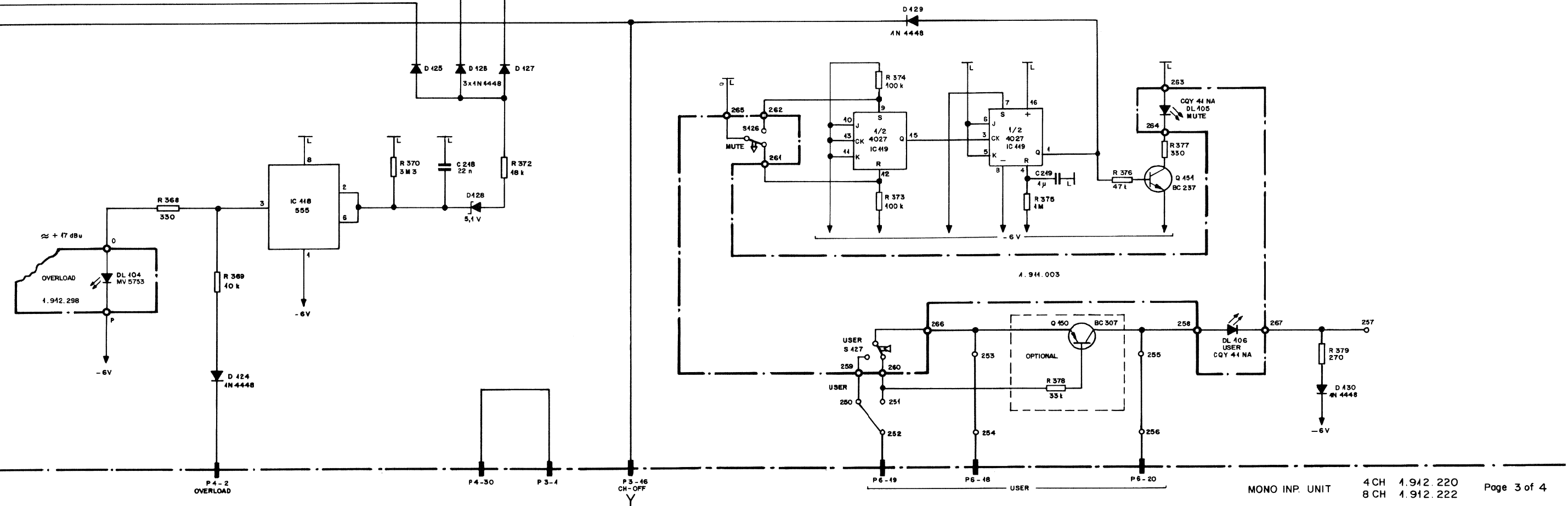
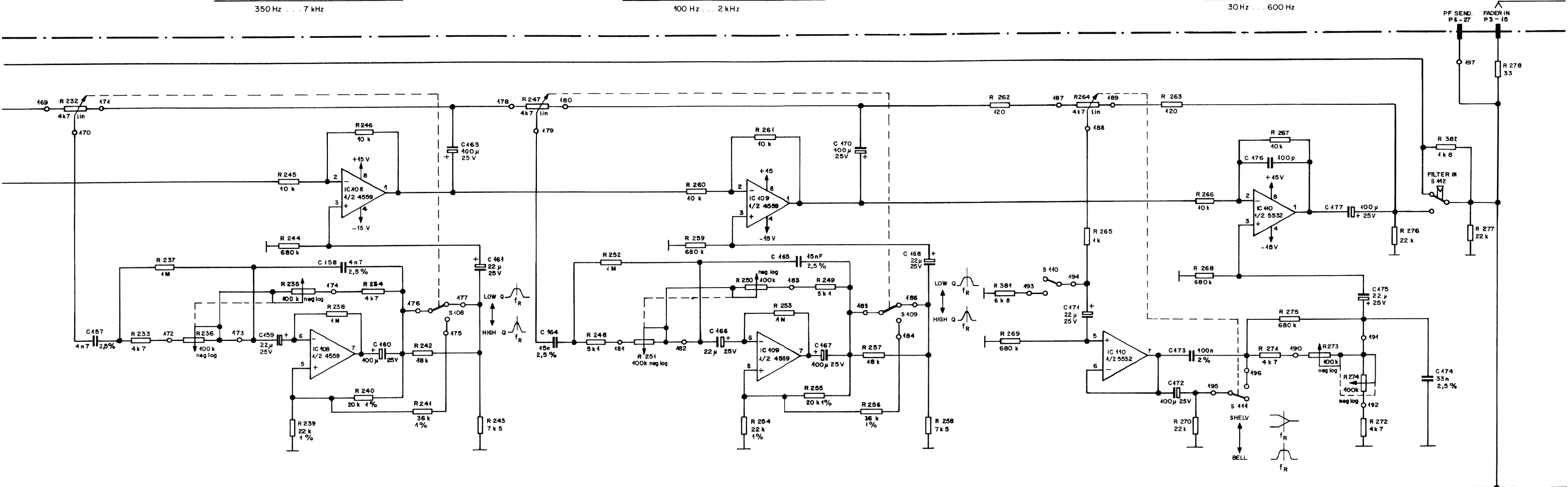

P 4 - 2
OVERLOAD

P 4 - 30

P 3 - 1

P 3 - 46
CH-OFF

P 6 - 19

P 6 - 48
USER

P 6 - 20

MONO INP. UNIT

4 CH 1.912.220
8 CH 1.912.222

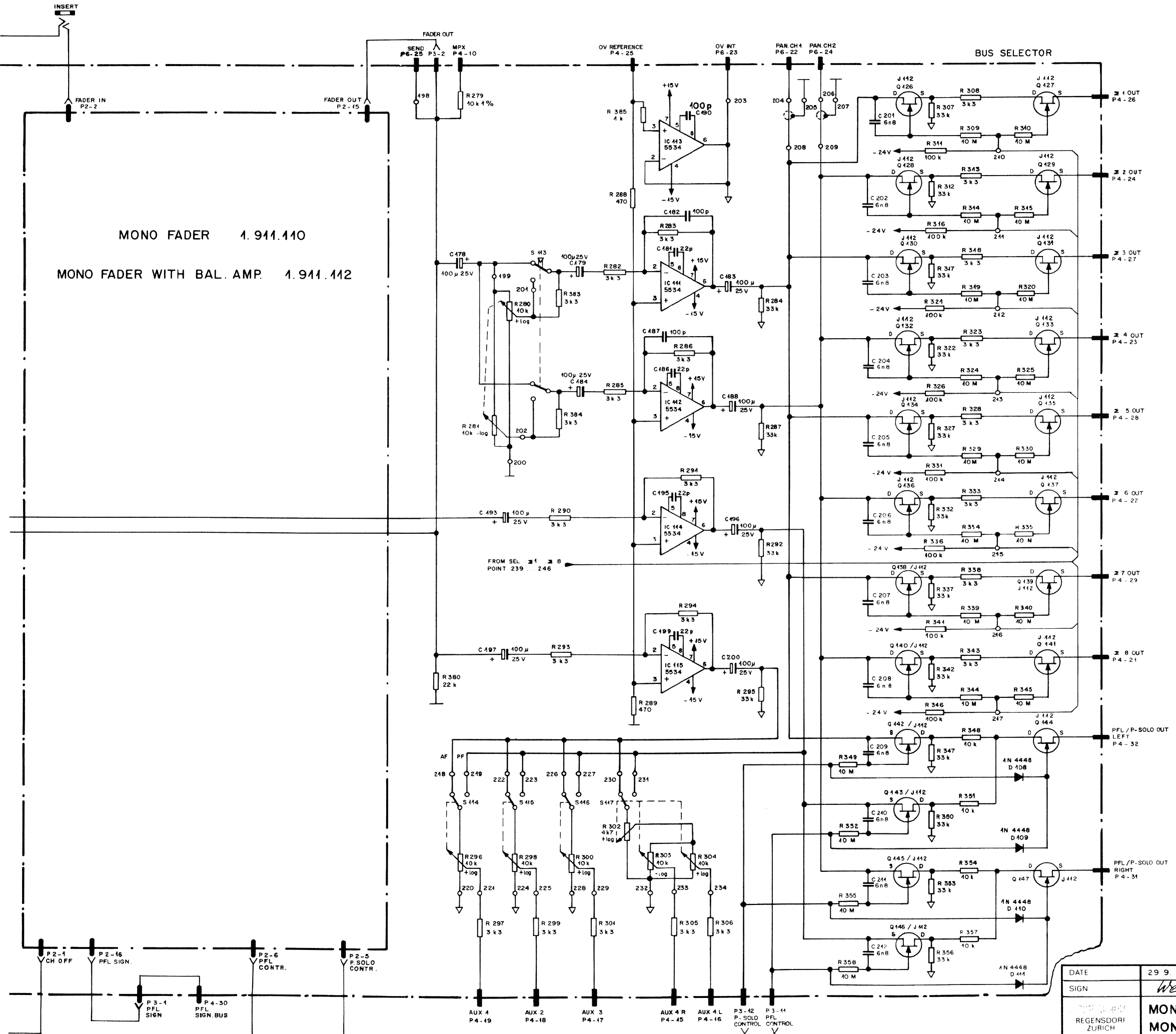

- P 4**
- 1 MASTER SIGN. DIGITAL INPUT
 - 2 OVERLOAD DIGITAL OUTPUT
 - 3 -6V
 - 4 OV DIGITAL
 - 5 -15V
 - 6 OV AUDIO
 - 7 +45V
 - 8 -24V
 - 9 +48V
 - 10 MPX ANALOG OUTPUT
 - 11 MIC. SIGN. DIGITAL OUTPUT
 - 12 a } ANALOG INPUT
 - 12 b }
 - 13 MIX DOWN DIGITAL INPUT
 - 14 AUX 4R OUT
 - 15 AUX 4L OUT
 - 16 AUX 3 OUT
 - 17 AUX 2 OUT
 - 18 AUX 1 OUT
 - 19 OV AUDIO
 - 20 USER
 - 21 PF OUT TO TB ANALOG OUTPUT
 - 22 PAN CH 1 ANALOG OUTPUT
 - 23 OV INT
 - 24 PAN CH 2 ANALOG OUTPUT
 - 25 AF OUT ANALOG OUTPUT
 - 26 OV AUDIO
 - 27 PF OUT ANALOG OUTPUT
 - 28 OV AUDIO
 - 29 P.FILTER OUT ANALOG OUTPUT
 - 30 P.FILTER IN ANALOG INPUT
 - 31 PFL / P-SOLO R ANALOG OUTPUT
 - 32 PFL / P-SOLO L ANALOG OUTPUT
- P 6**
- 1 a } TAPE ANALOG INPUT
 - 1 b }
 - 2 SCREEN
 - 3 a } LINE ANALOG INPUT
 - 3 b }
 - 4 SCREEN
 - 5 PHANTOM
 - 6 USER
 - 7 USER
 - 8 USER
 - 9 MIC. ANALOG INPUT
 - 10 SCREEN
 - 11 MIC. CUT DIGITAL INPUT
 - 12 USER
 - 13 USER
 - 14 a } P.FILTER OUT ANALOG OUTPUT
 - 14 b }
 - 15 MIC. ANALOG INPUT
 - 16 SCREEN
 - 17 MIC. CUT DIGITAL INPUT
 - 18 USER
 - 19 USER
 - 20 USER
 - 21 PF OUT TO TB ANALOG OUTPUT
 - 22 PAN CH 1 ANALOG OUTPUT
 - 23 OV INT
 - 24 PAN CH 2 ANALOG OUTPUT
 - 25 AF OUT ANALOG OUTPUT
 - 26 OV AUDIO
 - 27 PF OUT ANALOG OUTPUT
 - 28 OV AUDIO
 - 29 P.FILTER OUT ANALOG OUTPUT
 - 30 P.FILTER IN ANALOG INPUT
 - 31 LINE SIGN. DIGITAL OUTPUT
 - 32 TAPE SIGN. DIGITAL OUTPUT

- P 3**
- 1 PFL - SIGN BUS DIGITAL IN/OUT
 - 2 FADER OUT L ANALOG INPUT
 - 3 OV AUDIO R
 - 4 (FADER OUT R)
 - 5 -24V
 - 6 +45V
 - 7 OV AUDIO
 - 8 -45V
 - 9 OV DIGITAL
 - 10 -6V
 - 11 PFL CONTROL DIGITAL
 - 12 P-SOLO CONTROL DIGITAL
 - 13 (FADER INPUT R)
 - 14 OV AUDIO L
 - 15 FADER INPUT L ANALOG OUTPUT
 - 16 CH-OFF DIGITAL IN/OUT

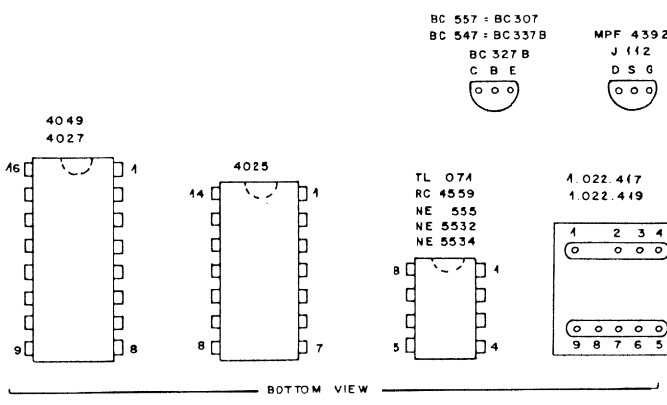

DATE	29.9.83	25.5.84	4.10.84		PAGE 4 OF 4
SIGN	<i>We</i>	<i>We</i>	<i>ul</i>		
REGENDORF ZÜRICH	MONO INPUT UNIT 4 CH			SC 1.912.220	
	MONO INPUT UNIT 8 CH			SC 1.912.222	

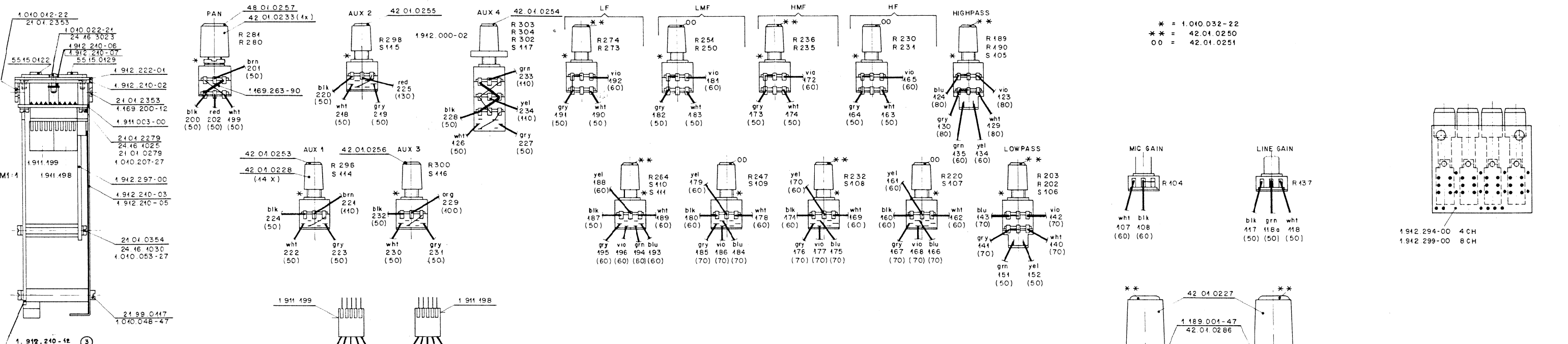

* = 1.010.032-22
 ** = 42.01.0250
 00 = 42.01.0251

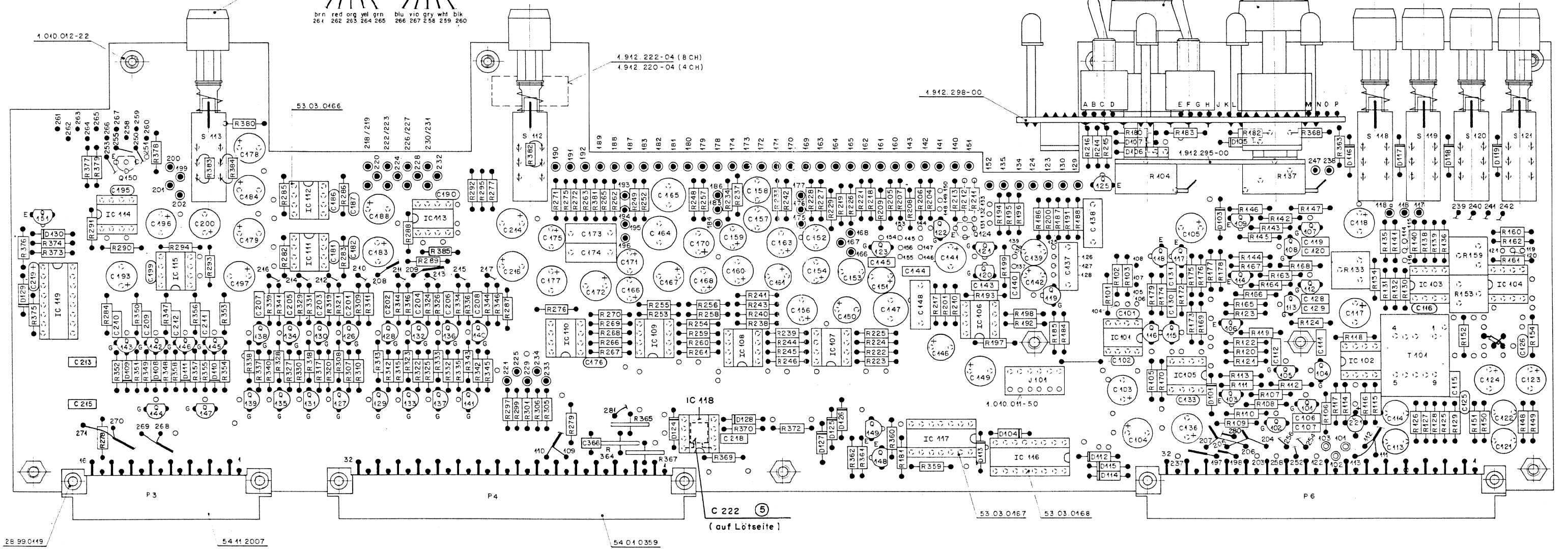

wiringdiagram (LL)	(KL)
255 TO 256 gry	440 TO 442 wht
253 TO 254 wht	409 TO 441 blu screen
250 TO 252 blik (390 mm)	208 TO 204 wht
280 TO 281 blik (200 mm)	205 screen
240 TO 239 brn	209 TO 206 wht
212 TO 240 org	207 screen
214 TO 241 grn	498 TO 268 wht
246 TO 242 vio	269 screen
241 red	197 TO 270 wht
243 yel	274 screen
245 blu	
247 gry	

4 CH-1.942.220-00	8 CH-1.942.222-00
PL 4.942.220-00	4.942.220-00
LL 4.942.220-93	4.942.222-93
KL 4.942.240-94	4.942.240-94

Norm-Nr.	30.4.90 Si	20.8.86 Si	25.6.86	1.09.84	6.1.83	48.11.82
Werkstoff						
DIN-Bez						
Abmessung						
Zugehörige Unterlagen						
***			Frei mass toleranz	Maßstab	1:1, 2:1	
Ersatz für			Datum	Gez	Gepr	Ges
Ersetzt durch			Kopie für		Kopie für	
STUOER REGENSDORF ZÜRICH			Mono Input Unit Pan 4 CH / 8 CH			1.942.220-00

C 416 / C 243 / C 215 / R 385 nachgezogen

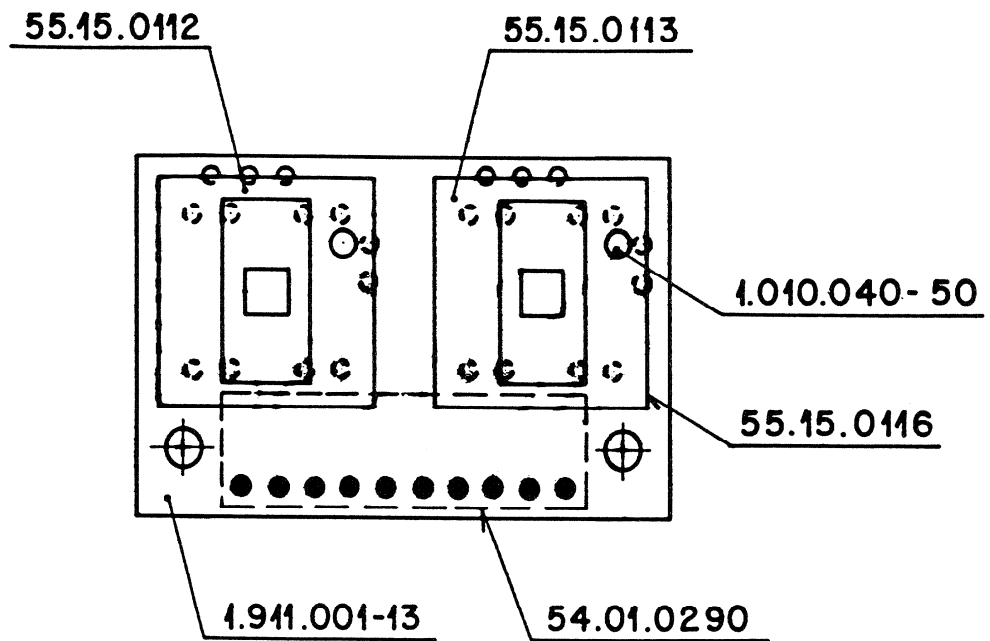

Werkstoff	Norm-Nr.:	Güte:							③	
	DIN-Bez.:	Oberfläche							②	
	Abmessung:	Beh.:							①	
Zugehörige Unterlagen:	Freimasstoleranz:	Maßstab:	19.5.82	Ho	✓				④	
	±	2 : 1	Ausgabe	Datum	Gez.	Gepr.	Ges.	Index		
Ersatz für:	Ersetzt durch:		Kopie für:							
STUDER REGENSDORF ZÜRICH			Benennung: Pushbutton Board N-L				Nummer: 1.911.003-00			

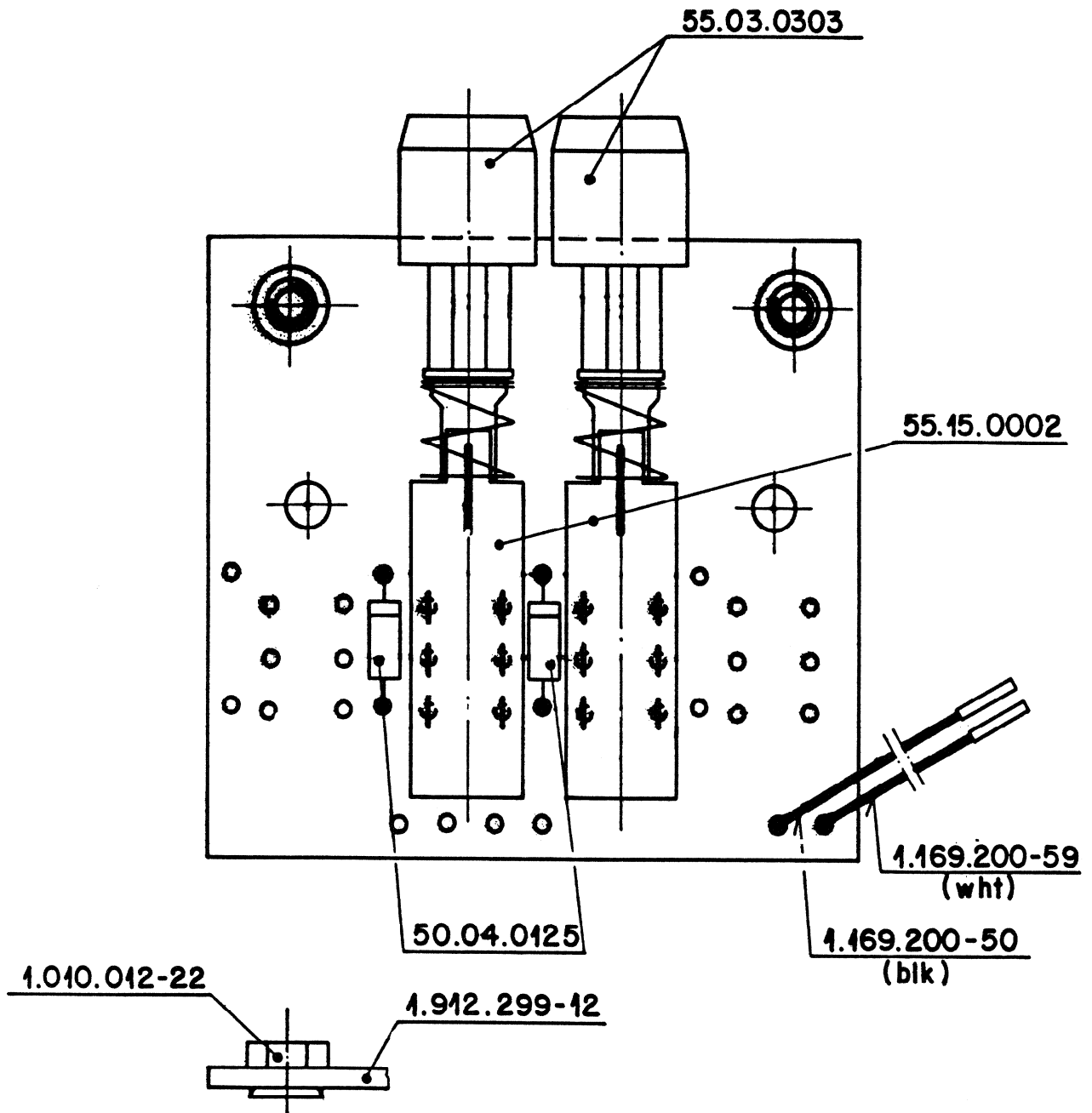

Werkstoff	Norm-Nr.:	Güte:		Änderung					③
	DIN-Bez.:	Oberfläche							
	Abmessung:	Beh.:							①
Zugehörige Unterlagen:	Freimaßtoleranz:	Maßstab:	4. 6. 82	Ho	W	de			①
	±	2 : 4	Datum	Gez.	Gepr.	Ges.			①
Ersatz für:	Ersetzt durch:		Kopie für:						
STUDER REGENSDORF ZÜRICH	Benennung: Bus Board 4 CH		Nummer: 1.912.294-00						

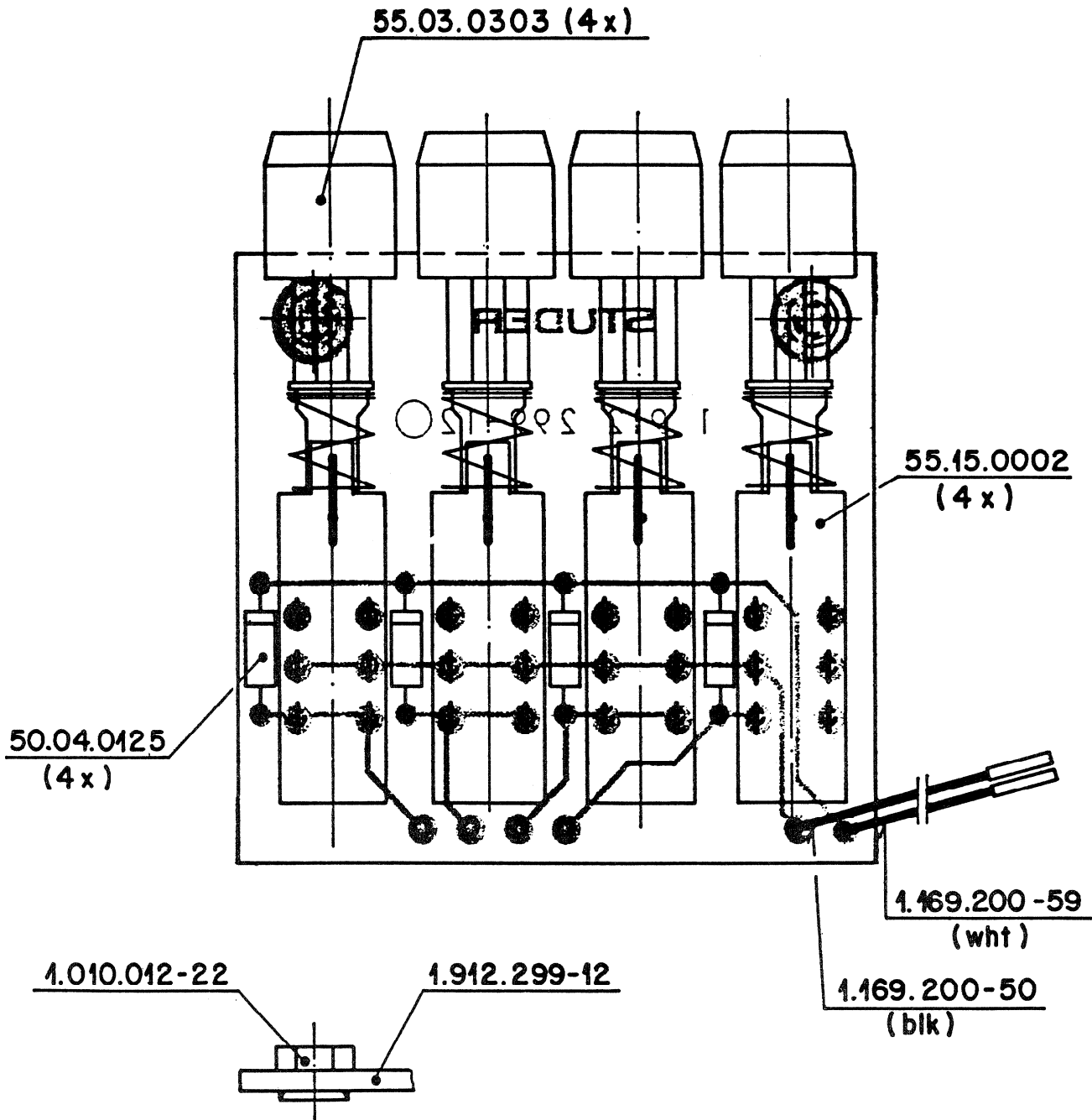

Werkstoff	Norm-Nr.:	Oberfläche	Güte:					③	
	DIN-Bez.:		Beh.:					②	
	Abmessung:							①	
Zugehörige Unterlagen:		Freimasstoleranz:	Maßstab:	4.6.82	Ho	V	Ge	④	
		±	2 : 1	Datum	Gez.	Gepr.	Geo.	Index	
Ersatz für:		Ersetzt durch:		Kopie für:					
STUDER REGENSDORF ZÜRICH		Bezeichnung: Bus Board 8 CH			Nummer: 1.912.299-00				

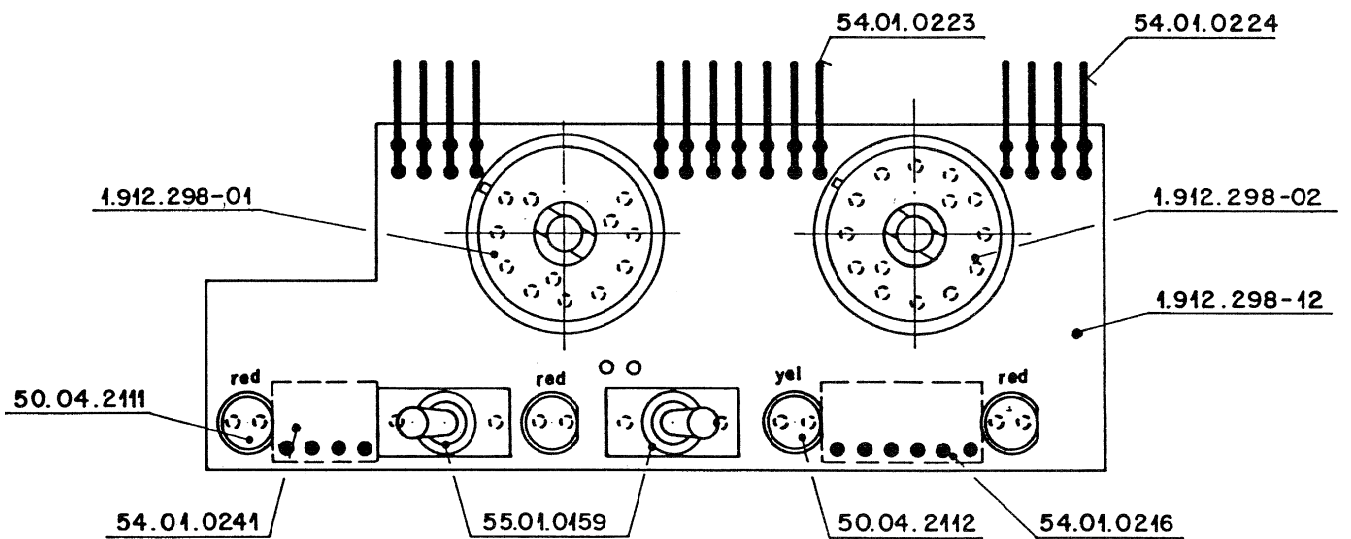
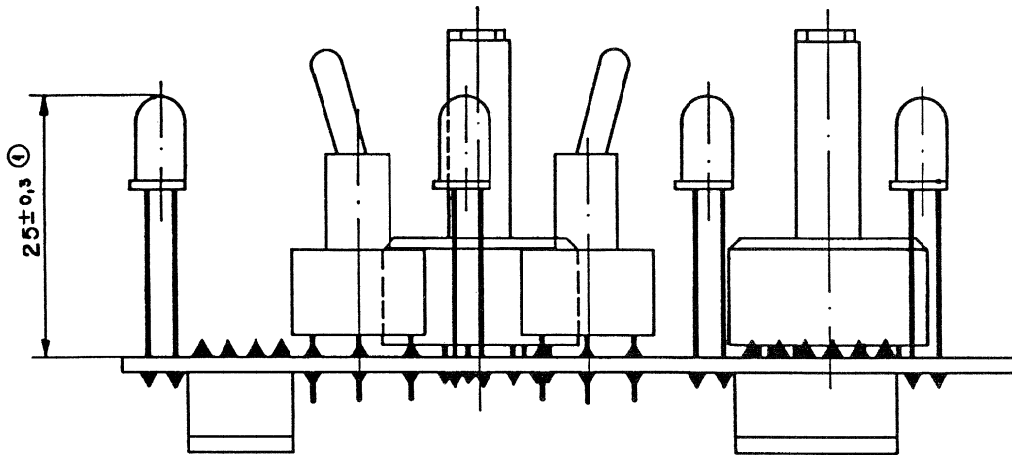

Version:	Norm-Nr.:	Güte:	Änderung				
	DIN-Bez.:		Oberfläche:				③
Abmessung:	Boh.:	Freimaßtoleranz:		1.9.83		AHo	
	Zugehörige Unterlagen:		Maßstab:	10.6.82	Ho		
Ersatz für:	Ersetzt durch:	Kopie für:	Datum	Ort	Gepr.	Gez.	Index
			STUWA REGENSDORF ZÜRICH	Benennung Switch-Board	Nummer: 1.912.298-00		

INDI POS NO	PART NO	VALUE	SPECIFICATIONS/EQUIVALENT	MFR
A 101	1.912.296		MIC. PREAMPL. TRANSFORMERLESS	
102	1.912.297		WIT TRAFD	
103	1.912.298		SWITCHBOARD	
104	1.912.299		BUS BOARD 8CH ONLY 8CH	
105	1.912.294		BUS BOARD 4CH *	
106	1.911.003		PUSHBUTTON	
C 101	59.34.2470	47 p		CER
102	59.34.2220	22 p		CER
103	59.22.5101	100 μ	16V	EL
104	59.22.5101	100 μ	16V	EL
105	59.22.5101	100 μ	16V	EL
106	59.06.0682	6,8 n	10% 63V	PE
107	59.06.0682	6,8 n	10% 63V	PE
111	59.06.0682	6,8 n	10% 63V	PE
112	59.06.0682	6,8 n	10% 63V	PE
113	59.05.1681	680 p	1% 630V	PP
114	59.05.1681	680 p	1% 630V	PP
115	59.06.0682	6,8 n	10% 63V	PE
116	59.34.4224	220 p		CER
117	59.22.5101	100 μ	16V	EL
118	59.22.5101	100 μ	16V	EL
119	59.06.0682	6,8 n	10% 63V	PE
120	59.06.0682	6,8 n	10% 63V	PE
121	59.05.1681	680 p	1% 630V	PP
122	59.05.1681	680 p	1% 630V	PP

INDI	DATE	NAME	CER: CERAMIC	SAL: SOLID ALUMINIUM
③	4.10.84	Ek	EL: ELECTROLYTIC	
②	22. Aug. 1983	Eckert	PC: POLYCARBONAT	
①	6. Jan. 1983	Eckert	PE: POLYESTER	* ONLY 4CH
○	2. Dez. 1981	Eckert	PP: POLYPROPYLEN	1.912.222.00

STUDER MONO INPUT UNIT PAN 4CH/8CH 1.912.220.00 PAGE 1 OF 21

13.046.578

INDI POS NO	PART NO	VALUE	SPECIFICATIONS/EQUIVALENT	MFR
C 123	59.22.5101	100 μ	16V EL	
124	59.22.5101	100 μ	16V EL	
125	59.34.4101	100 p		CER
126	59.34.4101	100 p		CER
128	59.06.0682	6,8 n	10% 63V	PE
129	59.06.0682	6,8 n	10% 63V	PE
130	59.06.0682	6,8 n	10% 63V	PE
131	59.06.0682	6,8 n	10% 63V	PE
133	59.34.2220	22 p		CER
136	59.22.5101	100 μ	16V EL	
137	59.99.0254	100 n	2% 63V	PC
138	59.99.0254	100 n	2% 63V	PC
139	59.22.5220	22 μ	16V	EL
140	59.06.0222	2,2 n	63V	PE
141	59.22.5101	100 μ	16V EL	
142	59.22.5220	22 μ	16V EL	
143	59.06.0682	6,8 n	10% 63V	PE
144	59.06.0682	6,8 n	10% 63V	PE
145	59.06.0682	6,8 n	10% 63V	PE
146	59.22.5220	22 μ	16V EL	
147	59.05.2153	15 n	25% 63V	PP
148	59.99.0514	33 n	2% 63V	PC
149	59.22.5101	100 μ	16V EL	
150	59.22.5220	22 μ	16V EL	
151	59.22.5220	22 μ	16V EL	
152	59.05.2472	4,7 n	25%	

INDI	DATE	NAME	CER: CERAMIC	SAL: SOLID ALUMINIUM
③	4.10.84	Ek	EL: ELECTROLYTIC	
②	22. Aug. 1983	Eckert	PC: POLYCARBONAT	
①	6. Jan. 1983	Eckert	PE: POLYESTER	* ONLY 4CH
○	2. Dez. 1981	Eckert	PP: POLYPROPYLEN	1.912.222.00

STUDER MONO INPUT 4CH/8CH 1.912.220.00 PAGE 2 OF 21

13.046.578

INDI POS NO	PART NO	VALUE	SPECIFICATIONS/EQUIVALENT	MFR
C 153	59.05.2152	15 n	25% 63V	PP
154	59.22.5220	22 μ	16V EL	
156	59.22.5101	100 μ	16V EL	
157	59.05.2472	4,7 n	25% 63V	PP
158	59.05.2472	4,7 n	25% 63V	PP
159	59.22.5220	22 μ	16V EL	
160	59.22.5101	100 μ	16V EL	
161	59.22.5220	22 μ	16V EL	
163	59.22.5101	100 μ	16V EL	
164	59.05.2153	15 n	25% 63V	PP
165	59.05.2153	15 n	25% 63V	PP
166	59.22.5220	22 μ	16V EL	
167	59.22.5101	100 μ	16V EL	
168	59.22.5220	22 μ	16V EL	
170	59.22.5101	100 μ	16V EL	
171	59.22.5220	22 μ	16V EL	
172	59.22.5101	100 μ	16V EL	
173	59.99.0254	100 n	2% 63V	PC
174	59.99.0514	33 n	2% 63V	PC
175	59.22.5220	22 μ	16V EL	
176	59.34.4101	100 p		CER
177	59.22.5101	100 μ	16V EL	
178	59.22.5101	100 μ	16V EL	
179	59.22.5101	100 μ	16V EL	
181	59.34.2220	22 p		CER
182	59.34.4101	100 p		CER

INDI	DATE	NAME	CER: CERAMIC	SAL: SOLID ALUMINIUM
③	4.10.84	Ek	EL: ELECTROLYTIC	
②	22. Aug. 1983	Eckert	PC: POLYCARBONAT	
①	6. Jan. 1983	Eckert	PE: POLYESTER	* ONLY 8CH
○	2. Dez. 1981	Eckert	PP: POLYPROPYLEN	1.912.222.00

STUDER MONO INPUT 4CH/8CH 1.912.220.00 PAGE 3 OF 21

13.046.578

INDI POS NO	PART NO	VALUE	SPECIFICATIONS/EQUIVALENT	MFR
C 183	59.22.5101	100 μ	16V EL	
184	59.22.5101	100 μ	16V EL	
186	59.34.2220	22 p		CER
187	59.34.4101	100 p		CER
188	59.22.5101	100 μ	16V EL	
③ 190	59.34.4101	100 p		CER
193	59.22.5101	100 μ	16V EL	
195	59.34.2220	22 p		CER
196	59.22.5101	100 μ	16V EL	
197	59.22.5101	100 μ	16V EL	
199	59.34.2220	22 p		CER
200	59.22.5101	100 μ	16V EL	
201	59.06.0682	6,8 n	10% 63V	PE
202	59.06.0682	6,8 n	10% 63V	PE
203	59.06.0682	6,8 n	10% 63V	PE
204	59.06.0682	6,8 n	10% 63V	PE
205	59.06.0682	6,8 n	10% 63V	PE *
206	59.06.0682	6,8 n	10% 63V	PE *
207	59.06.0682	6,8 n	10% 63V	PE *
208	59.06.0682	6,8 n	10% 63V	PE *
209	59.06.0682	6,8 n	10% 63V	PE
210	59.06.0682	6,8 n	10% 63V	PE
211	59.06.0682	6,8 n	10% 63V	PE
212	59.06.0682	6,8 n	10% 63V	PE

INDI	DATE	NAME	CER: CERAMIC	SAL: SOLID ALUMINIUM
③	4.10.84	Ek	EL: ELECTROLYTIC	
②	22. Aug. 1983	Eckert	PC: POLYCARBONAT	
①	6. Jan. 1983	Eckert	PE: POLYESTER	* ONLY 8CH
○	2. Dez. 1981	Eckert	PP: POLYPROPYLEN	1.912.222.00

STUDER MONO INPUT 4CH/8CH 1.912.220.00 PAGE 4 OF 21

13.046.578

INDI	POS NO	PART NO	VALUE	SPECIFICATIONS/EQUIVALENT	MFR
C	243	59.06.0223	22 n	PE	
C	244	59.22.5104	400 μ	16V EL	
2	245	59.06.0223	22 n	PE	
	246	59.22.5104	100 μ	16V EL	
	248	59.06.0223	22 n	PE	
	249	59.26.9109	1 μ	6V SAL	
	221	59.30.2220	22 μ	6V TA	
D	101	50.04.0125	1N 4448		
	103	50.04.0125	1N 4448		
	104	50.04.0125	1N 4448		
	105	50.04.0125	1N 4448		
	106	50.04.0125	1N 4448		
	107	50.04.0125	1N 4448		
	108	50.04.0125	1N 4448		
	109	50.04.0125	1N 4448		
	110	50.04.0125	1N 4448		
	111	50.04.0125	1N 4448		
	112	50.04.0125	1N 4448		
	113	50.04.0125	1N 4448		
	114	50.04.0125	1N 4448		
	115	50.04.0125	1N 4448		
	116	50.04.0125	1N 4448	*	
	117	50.04.0125	1N 4448		
	118	50.04.0125	1N 4448		

INDI	DATE	NAME			
④					
③	4.10.84	<i>fa</i>			
②	22 Aug 83	Eckert			
①	6 Jan 83	Eckert			
○	2 Dez. 81	Eckert			
			* ONLY 8CH		
STUDER	MONO	INPUT	4CH/8CH	1.912.220.00	PAGE 5 OF 21

13.046.578

INDI	POS NO	PART NO	VALUE	SPECIFICATIONS/EQUIVALENT	MFR
D	119	50.04.0125	1N 4448	*	
	120	50.04.0125	1N 4448	*	
	121	50.04.0125	1N 4448		
	122	50.04.0125	1N 4448		
	123	50.04.0125	1N 4448	*	
	124	50.04.0125	1N 4448		
	125	50.04.0125	1N 4448		
	126	50.04.0125	1N 4448		
	127	50.04.0125	1N 4448		
	128	50.04.1112	Z 5V1	400mW	
	129	50.04.0125	1N 4448		
	130	50.04.0125	1N 4448		
DL	101	50.04.2111	MV 5753		
	102	50.04.2112	MV 5353		
	103	50.04.2111	MV 5753		
	104	50.04.2111	MV 5753		
	105	1.010.040.50	CGY 41 NA		
	106	1.010.040.50	CGY 41 NA		
IF	101	50.05.0244	NE 5534NB		
	102	50.09.0103	TL 071 CP		
	103	50.09.0105	NE 5532 N		

INDI	DATE	NAME			
④					
③	4.10.84	<i>fa</i>			
②	22 Aug 83	Eckert			
①	6 Jan 83	Eckert			
○	2 Dez. 81	Eckert			
			* ONLY 8CH		
STUDER	MONO	INPUT	4CH/8CH	1.912.220.00	PAGE 6 OF 21

13.046.578

INDI	POS NO	PART NO	VALUE	SPECIFICATIONS/EQUIVALENT	MFR
IC	104	50.09.0105	NE 5532 N		
	105	50.05.0243	NE 5534 N		
	106	50.09.0105	NE 5532 N		
	107	50.09.0107	RC 4559 NB		
	108	50.09.0107	RC 4559 NB		
	109	50.09.0107	RC 4559 NB		
	110	50.09.0105	NE 5532 N		
	111	50.05.0243	NE 5534 N		
	112	50.05.0243	NE 5534 N		
	113	50.05.0243	NE 5534 N		
	114	50.05.0243	NE 5534 N		
	115	50.05.0243	NE 5534 N		
	116	50.07.0049	4049		
	117	50.07.0042	4025		
	118	50.05.0158	555		
	119	50.07.0027	4027		
J	101	54.01.0216	6 P		
P	3	54.11.2007	2*8		
	4	54.01.0359	2*6		
	6	54.01.0359	2*6		

INDI	DATE	NAME			
④					
③	4.10.84	<i>fa</i>			
②	22 Aug 83	Eckert			
①	6 Jan 83	Eckert			
○	2 Dez. 81	Eckert			
			* ONLY 8CH		
STUDER	MONO	INPUT	4CH/8CH	1.912.220.00	PAGE 7 OF 21

13.046.578

INDI	POS NO	PART NO	VALUE	SPECIFICATIONS/EQUIVALENT	MFR
Q	101	50.03.0350	J 112		
	102	50.03.0350	J 112		
	103	50.03.0515	BC 307		
	104	50.03.0350	J 112		
	105	50.03.0350	J 112		
	106	50.03.0515	BC 307		
	107	50.03.0350	J 112		
	108	50.03.0350	J 112		
	109	50.03.0515	BC 307		
	112	50.03.0350	J 112		
	113	50.03.0350	J 112		
	114	50.03.0515	BC 307		
	115	50.03.0350	J 112		
	116	50.03.0350	J 112		
	117	50.03.0515	BC 307		
	118	50.03.0515	BC 307		
	119	50.03.0350	J 112		
	120	50.03.0350	J 112		
	121	50.03.0515	BC 307		
	122	50.03.0350	J 112		
	123	50.03.0350	J 112		
	124	50.03.0515	BC 307	OPTIONAL	
	125	50.03.0515	BC 307		
	126	50.03.0350	J 112		
	127	50.03.0350	J 112		
	128	50.03.0350	J 112		
	129	50.03.0350	J 112		
	130	50.03.0350	J 112		

INDI	DATE	NAME			
④					
③	4.10.84	<i>fa</i>			
②	22 Aug 83	Eckert			
①	6 Jan 83	Eckert			
○	2 Dez. 81	Eckert			
			* ONLY 8CH		
STUDER	MONO	INPUT	4CH/8CH	1.912.220.00	PAGE 8 OF 21

13.046.578

IND	POS NO	PART NO	VALUE	SPECIFICATIONS/EQUIVALENT	MFR
Q	131	50.03.0350	J 112		
	132	50.03.0350	J 112		
	133	50.03.0350	J 112		
	134	50.03.0350	J 112	*	
	135	50.03.0350	J 112	*	
	136	50.03.0350	J 112	*	
	137	50.03.0350	J 112	*	
	138	50.03.0350	J 112	*	
	139	50.03.0350	J 112	*	
	140	50.03.0350	J 112	*	
	141	50.03.0350	J 112	*	
	142	50.03.0350	J 112		
	143	50.03.0350	J 112		
	144	50.03.0350	J 112		
	145	50.03.0350	J 112		
	146	50.03.0350	J 112		
	147	50.03.0350	J 112		
	148	50.03.0436	BC 237		
	149	50.03.0436	BC 237		
	150	50.03.0515	BC 307	OPTIONAL	
	151	50.03.0436	BC 237		

IND	DATE	NAME	
④			
③	4. 10. 84	<i>fg</i>	
②	22. Aug. 83	Eckert	
①	6. Jan. 83	Eckert	* ONLY 8CH
○	2. Dez. 81	Eckert	

STUDER MONO INPUT 4CH / 8CH 1.912.220.00 PAGE 9 OF 21

13.046.578

IND	POS NO	PART NO	VALUE	SPECIFICATIONS/EQUIVALENT	MFR
R	101	57.11.4472	4,7 k	5%	
	102	.4561	580	5%	
	103	.4271	270	5%	
	104	1.912.001.22	40 k	POS. LOG. POT	
	105	57.11.4223	22 k		
	106	.4331	330	5%	
	107	.4103	40 k		
	108	.6106	40 M		
	109	.6106	40 M		
	110	.4104	100 k		
	111	.4224	220 k		
	112	.4105	1 M		
	113	.4103	40 k		
	114	.4472	4,7 k	2%	
	115	.4154	150 k	2%	
	116	.4472	4,7 k	2%	
	117	.4154	150 k	2%	
	118	.4331	330	5%	
	119	.4103	40 k		
	120	.6106	40 M		
	121	.6106	40 M		
	122	.4104	100 k		
	123	.4224	220 k		
	124	.4105	1 M		
	125	.3152	15 k	1%	
	126	.3392	33 k	1%	
	127	.3152	15 k	1%	
	128	.3392	33 k	1%	
	129	.4182	48 k	5%	
	130	.3752	75 k	5%	

IND	DATE	NAME	
④			
③	4. 10. 84	<i>fg</i>	
②	22. Aug. 83	Eckert	
①	6. Jan. 83	Eckert	
○	2. Dez. 81	Eckert	

STUDER MONO INPUT 4CH / 8CH 1.912.220.00 PAGE 10 OF 21

13.046.578

IND	POS NO	PART NO	VALUE	SPECIFICATIONS/EQUIVALENT	MFR
R	131	57.11.3752	75 k	5%	
	132	.4181	480	5%	
	133	58.01.8102	1 k	TRIM	
	134	57.11.4271	270	5%	
	135	.4272	27 k	5%	
	136	.4152	15 k	5%	
	137	1.912.001.21	40 k	LIN POT	
	138	57.11.4222	22 k	5%	
	139	.4152	15 k	5%	
	140	.4102	1 k	5%	
	141	.4471	470	5%	
	142	.4103	40 k		
	143	.6106	40 M		
	144	.6106	40 M		
	145	.4104	100 k		
	146	.4224	220 k		
	147	.4105	1 M		
	148	.3152	15 k	1%	
	149	.3392	33 k	1%	
	150	.3152	15 k	1%	
	151	.3392	33 k	1%	
	152	.4332	33 k		
	153	58.01.8501	500	TRIM	
	154	57.11.3362	36 k	2%	
	159	58.01.8202	2 k	TRIM	
	160	57.11.4331	330		

IND	DATE	NAME	
④			
③	4. 10. 84	<i>fg</i>	
②	22. Aug. 83	Eckert	
①	6. Jan. 83	Eckert	
○	2. Dez. 81	Eckert	

STUDER MONO INPUT 4CH / 8CH 1.912.220.00 PAGE 11 OF 21

13.046.578

IND	POS NO	PART NO	VALUE	SPECIFICATIONS/EQUIVALENT	MFR
R	161	57.11.4102	1 k	5%	
	162	.4471	470	5%	
	163	.4103	40 k		
	164	.6106	40 M		
	165	.6106	40 M		
	166	.4104	100 k		
	167	.4224	220 k		
	168	.4105	1 M		
	169	.3302	3 k	2%	
	170	.4332	33 k	2%	
	172	.6106	40 M		
	173	.4223	22 k		
	174	.6106	40 M		
	175	.4104	100 k		
	176	.4105	1 M		
	177	.4104	100 k		
	178	.4271	270		
	179	.4224	220 k		
	180	.4473	47 k		
	181	.4103	40 k		
	182	.4224	220 k		
	183	.4331	330		
	184	.3132	13 k	2%	
	185	.4222	22 k	2%	
	186	.4562	56 k	5%	
	187	.4474	470 k	5%	
	188	.4562	56 k		
	189	1.912.001.52	47 k		
	190	1.912.001.52	47 k	POT. NEG. LOG.	

IND	DATE	NAME	
④			
③	4. 10. 84	<i>fg</i>	
②	22. Aug. 83	Eckert	
①	6. Jan. 83	Eckert	
○	2. Dez. 81	Eckert	

STUDER MONO INPUT 4CH / 8CH 1.912.220.00 PAGE 12 OF 21

13.046.578

IND	POS NO	PART NO	VALUE	SPECIFICATIONS/EQUIVALENT	MFR
R	191	57.11.4684	680	k	
	192	.4684	680	k	
	193	.6106	40	M	
	194	.4104	100	k	
	195	.4105	1	M	
	196	.4473	47	k	
	197	.4684	680	k 5%	
	198	.3682	68	k 1%	
	199	.3392	39	k 1%	
	200	.4474	470	k 5%	
	201	.6106	40	M	
	202	1.912.001.51	40	k	
	203	1.912.001.51	40	k	POT. NEG. LOG.
	204	57.11.4331	330	5%	
	205	.4331	330	5%	
	206	.4102	1	k 5%	
	207	.4102	1	k 5%	
	208	.6106	40	M	
	209	.6106	40	M	
	210	.4684	680	k	
	211	.4104	100	k	OPTIONAL
	212	.4105	1	M	OPTIONAL
	213	.4473	47	k	
	214	.4104	100	k	
	215	.4104	100	k	
	216	.4331	330		
	217	.4223	22	k	
	218	.4121	120	5%	
	219	.4121	120	5%	
	220	1.912.001.41	47	k	LIN POT.

IND	DATE	NAME
④		
③	4.10.84	4
②	22. Aug. 83	Eckert
①	6. Jan. 83	Eckert
○	2. Dez. 81	Eckert

STUDER MONO INPUT 4CH/8CH 1.912.220.00 PAGE 13 OF 21

13.046.578

IND	POS NO	PART NO	VALUE	SPECIFICATIONS/EQUIVALENT	MFR
R	221	57.11.4102	1	k	
	222	.4103	40	k 5%	
	223	.4103	40	k 5%	
	224	.4684	680	k	
	225	.4684	680	k	
	226	.4103	40	k 5%	
	227	.4684	680	k	
	228	.4392	39	k 5%	
	229	.4392	39	k 5%	
	230	1.912.001.31	100	k	
	231	1.912.001.31	100	k	NEG. LOG. POT.
	232	1.912.002.41	47	k	LIN POT.
	233	57.11.4472	47	k 5%	
	234	.4472	47	k 5%	
	235	1.912.001.31	100	k	
	236	1.912.001.31	100	k	NEG. LOG. POT.
	237	57.11.4105	1	M	
	238	.4105	1	M	
	239	.3223	22	k 1%	
	240	.3203	20	k 1%	
	241	.3363	36	k 1%	
	242	.4183	18	k 2%	
	243	.3752	75	k 1%	
	244	.4684	680	k	
	245	.4103	40	k 5%	
	246	.4103	40	k 5%	
	247	1.912.001.41	47	k	LIN. POT.
	248	57.11.3512	51	k 5%	
	249	.3512	51	k 5%	

IND	DATE	NAME
④		
③	4.10.84	4
②	22. Aug. 83	Eckert
①	6. Jan. 83	Eckert
○	2. Dez. 81	Eckert

STUDER MONO INPUT 4CH/8CH 1.912.220.00 PAGE 14 OF 21

13.046.578

IND	POS NO	PART NO	VALUE	SPECIFICATIONS/EQUIVALENT	MFR
R	250	1.912.001.31	100	k	
	251	1.912.001.31	100	k	NEG. LOG. POT.
	252	57.11.4105	1	M	
	253	.4105	1	M	
	254	.3223	22	k 1%	
	255	.3203	20	k 1%	
	256	.3363	36	k 1%	
	257	.4183	18	k 2%	
	258	.3752	75	k 1%	
	259	.4684	680	k	
	260	.4103	40	k 5%	
	261	.4103	40	k 5%	
	262	.4121	120	5%	
	263	.4121	120	5%	
	264	1.912.001.41	47	k	LIN. POT.
	265	57.11.4102	1	k 5%	
	266	.4103	40	k 5%	
	267	.4103	40	k 5%	
	268	.4684	680	k	
	269	.4684	680	k	
	270	.4223	22	k	
	271	.4472	47	k 5%	
	272	.4472	47	k 5%	
	273	1.912.001.31	100	k	
	274	1.912.001.31	100	k	NEG. LOG. POT.
	275	57.11.4684	680	k	
	276	.4223	22	k	
	277	.4223	22	k	
	278	.4330	33		
	279	.3103	40	k 1%	

IND	DATE	NAME
④		
③	4.10.84	4
②	22. Aug. 83	Eckert
①	6. Jan. 83	Eckert
○	2. Dez. 81	Eckert

STUDER MONO INPUT 4CH/8CH 1.912.220.00 PAGE 15 OF 21

13.046.578

IND	POS NO	PART NO	VALUE	SPECIFICATIONS/EQUIVALENT	MFR
R	280	1.912.001.35	40	k	POS. LOG. } POT.
	281	1.912.001.35	40	k	NEG. LOG. } POT.
	282	57.11.4332	33	k 5%	
	283	.4332	33	k 5%	
	284	.4333	33	k	
	285	.4332	33	k 5%	
	286	.4332	33	k 5%	
	287	.4333	33	k	
	288	.4471	470		
	289	.4471	470		
	290	.4332	33	k 5%	
	291	.4332	33	k 5%	
	292	.4333	33	k	
	293	.4332	33	k 5%	
	294	.4332	33	k 5%	
	295	.4333	33	k	
	296	1.912.001.42	40	k	POS. LOG. POT.
	297	57.11.4332	33	k 5%	
	298	1.912.001.42	40	k	POS. LOG. POT.
	299	57.11.4332	33	k 5%	
	300	1.912.001.42	40	k	POS. LOG. POT.
	301	57.11.4332	33	k 5%	
	302	1.912.001.43	47	k	POS. LOG. } POT.
	303	1.912.001.43	40	k	POS. LOG. } POT.
	304	1.912.001.43	40	k	NEG. LOG. }
	305	57.11.4332	33	k 5%	
	306	.4332	33	k 5%	
	307	.4333	33	k	
	308	.4332	33	k 5%	
	309	.6106	40	M	

IND	DATE	NAME
④		
③	4.10.84	4
②	22. Aug. 83	Eckert
①	6. Jan. 83	Eckert
○	2. Dez. 81	Eckert

STUDER MONO INPUT 4CH/8CH 1.912.220.00 PAGE 16 OF 21

13.046.578

INDI	POS NO	PART NO	VALUE	SPECIFICATIONS/EQUIVALENT	MFR
R	310	57.11.6106	40 M		
	311	.4104	100 k		
	312	.4333	33 k		
	313	.4332	33 k	5%	
	314	.6106	10 M		
	315	.6106	10 M		
	316	.4104	100 k		
	317	.4333	33 k		
	318	.4332	33 k	5%	
	319	.6106	10 M		
	320	.6106	10 M		
	321	.4104	100 k		
	322	.4333	33 k		
	323	.4332	33 k	5%	
	324	.6106	10 M		
	325	.6106	10 M		
	326	.4104	100 k		
	327	.4333	33 k		*
	328	.4332	33 k	5%	*
	329	.6106	10 M		*
	330	.6106	10 M		*
	331	.4104	100 k		*
	332	.4333	33 k		*
	333	.4332	33 k	5%	*
	334	.6106	10 M		*
	335	.6106	10 M		*
	336	.4104	100 k		*
	337	.4333	33 k		*
	338	.4332	33 k	5%	*
	339	.6106	10 M		*

INDI	POS NO	PART NO	VALUE	SPECIFICATIONS/EQUIVALENT	MFR
R	340	57.11.6106	10 M		*
	341	.4104	100 k		*
	342	.4333	33 k		*
	343	.4332	33 k	5%	*
	344	.6106	10 M		*
	345	.6106	10 M		*
	346	.4104	100 k		*
	347	.4333	33 k		
	348	.4103	10 k	5%	
	349	.6106	10 M		
	350	.4333	33 k		
	351	.4103	10 k	5%	
	352	.6106	10 M		
	353	.4333	33 k		
	354	.4103	10 k	5%	
	355	.6106	10 M		
	356	.4333	33 k		
	357	.4103	10 k	5%	
	358	.6106	10 M		
	359	.4104	100 k		
	360	.4105	1 M		
	361	.4105	1 M		
	362	.4105	1 M		
	363	.4104	100 k		
	364	57.99.0209	56	PTC	
	365	57.99.0209	56	PTC	
	366	57.99.0206	50	PTC	
	367	57.99.0209	56	PTC	
	368	57.11.4331	330		
	369	.4103	10 k		

INDI	DATE	NAME	
④			
③	4.10.84		
②	22. Aug. 83	Eckert	
①	6. Jan. 83	Eckert	* ONLY 8CH
○	2. Dez. 81	Eckert	

STUDER MONO INPUT 4CH/8CH 1.912.220.00 PAGE 17 OF 21

INDI	DATE	NAME	
④			
③	4.10.84		
②	22. Aug. 83	Eckert	
①	6. Jan. 83	Eckert	* ONLY 8CH
○	2. Dez. 81	Eckert	

STUDER MONO INPUT 4CH/8CH 1.912.220.00 PAGE 18 OF 21

13.046.578

13.046.578

INDI	POS NO	PART NO	VALUE	SPECIFICATIONS/EQUIVALENT	MFR
R	370	57.11.6335	33 M		
	372	.4183	18 k	5%	
	373	.4104	100 k		
	374	.4104	100 k		
	375	.4105	1 M		
	376	.4473	47 k		
	377	.4331	330		
	378	.4333	33 k	OPTIONAL	
	379	.4271	270		
	380	.4223	22 k		
	381	.3682	68 k	1%	
1	382	.4182	18 k		
1	383	.4332	33 k		
1	384	.4332	33 k		
2	385	.4102	1 k		
S	101	1.912.298.01	1*9	ROTARY	
	102	1.912.298.02	3*4	ROTARY	
	103	55.04.0159	1p	TOGGLE	
	104	55.04.0159	1p	TOGGLE	
	105		1p ON	COMBINED WITH R189/R190	
	106		1p ON	" R202/R203	
	107		2p	" R220	
	108		2p	" R232	
	109		2p	" R247	
	110		1p		
	111		1p	" R264	
	112	55.15.0003	2p	PUSHBUTTON	
		55.03.0303		KNOB RED INDIC	
	113	55.15.0003	2p	PUSHBUTTON	

INDI	POS NO	PART NO	VALUE	SPECIFICATIONS/EQUIVALENT	MFR
		55.03.0303		KNOB RED INDIC	
S	114			COMBINED WITH R296	
	115			" R298	
	116			" R300	
	117			" R302/R303/R304	
	118	55.15.0002	2p	PUSHBUTTON	*
		55.03.0303		KNOB RED INDIC	*
	119	55.15.0002	2p	PUSHBUTTON	
		55.03.0303		KNOB RED INDIC	
	120	55.15.0002	2p	PUSHBUTTON	
		55.03.0303		KNOB RED INDIC	
	121	55.15.0002	2p	PUSHBUTTON	*
		55.03.0303		KNOB RED INDIC	*
	122	55.15.0002	2p	PUSHBUTTON	*
		55.03.0303		KNOB RED INDIC	*
	123	55.15.0002	2p	PUSHBUTTON	
		55.03.0303		KNOB RED INDIC	
	124	55.15.0002	2p	PUSHBUTTON	
		55.03.0303		KNOB RED INDIC	
	125	55.15.0002	2p	PUSHBUTTON	*
		55.03.0303		KNOB RED INDIC	*
	126	55.15.0112		PUSHBUTTON	
		55.15.0116		BEZEL BLACK	
		55.15.0122		KNOB RED	
	127	55.15.0113		PUSHBUTTON	
		55.15.0116		BEZEL BLACK	
		55.15.0129		KNOB WHITE	

INDI	DATE	NAME	
④			
③	4.10.84		
②	22. Aug. 83	Eckert	
①	6. Jan. 83	Eckert	
○	2. Dez. 81	Eckert	

STUDER MONO INPUT 4CH/8CH 1.912.220.00 PAGE 19 OF 21

INDI	DATE	NAME	
④			
③	4.10.84		
②	22. Aug. 83	Eckert	
①	6. Jan. 83	Eckert	* ONLY 8CH
○	2. Dez. 81	Eckert	

STUDER MONO INPUT 4CH/8CH 1.912.220.00 PAGE 20 OF 21

13.046.578

13.046.578

INDI	POS NO	PART NO	VALUE	SPECIFICATIONS/EQUIVALENT	MFR
	T 101	1.022.419.00			
	XIC	53.03.0166	8p	IC SOCKET	
		53.03.0167	14p	"	
		53.03.0168	16p	"	
<u>MODIFICATIONS</u>					
1	6. Jan. 83	No interrupt of the switches	EQUALIZER and PAN		
		R 382	open →	1k8	
		R 383	open →	3k3	
		R 384	open →	3k3	
2	22. Aug. 83	Improvement of	oscillation		
		C 213	open →	22nF	
		C 215	open →	22nF	
		R 385	open →	1k2	

INDI	DATE	NAME
④		
③	4.10.84	<i>E</i>
②	22. Aug. 83	Eckert
①	6. Jan. 83	Eckert
○	2. Dez. 81	Eckert

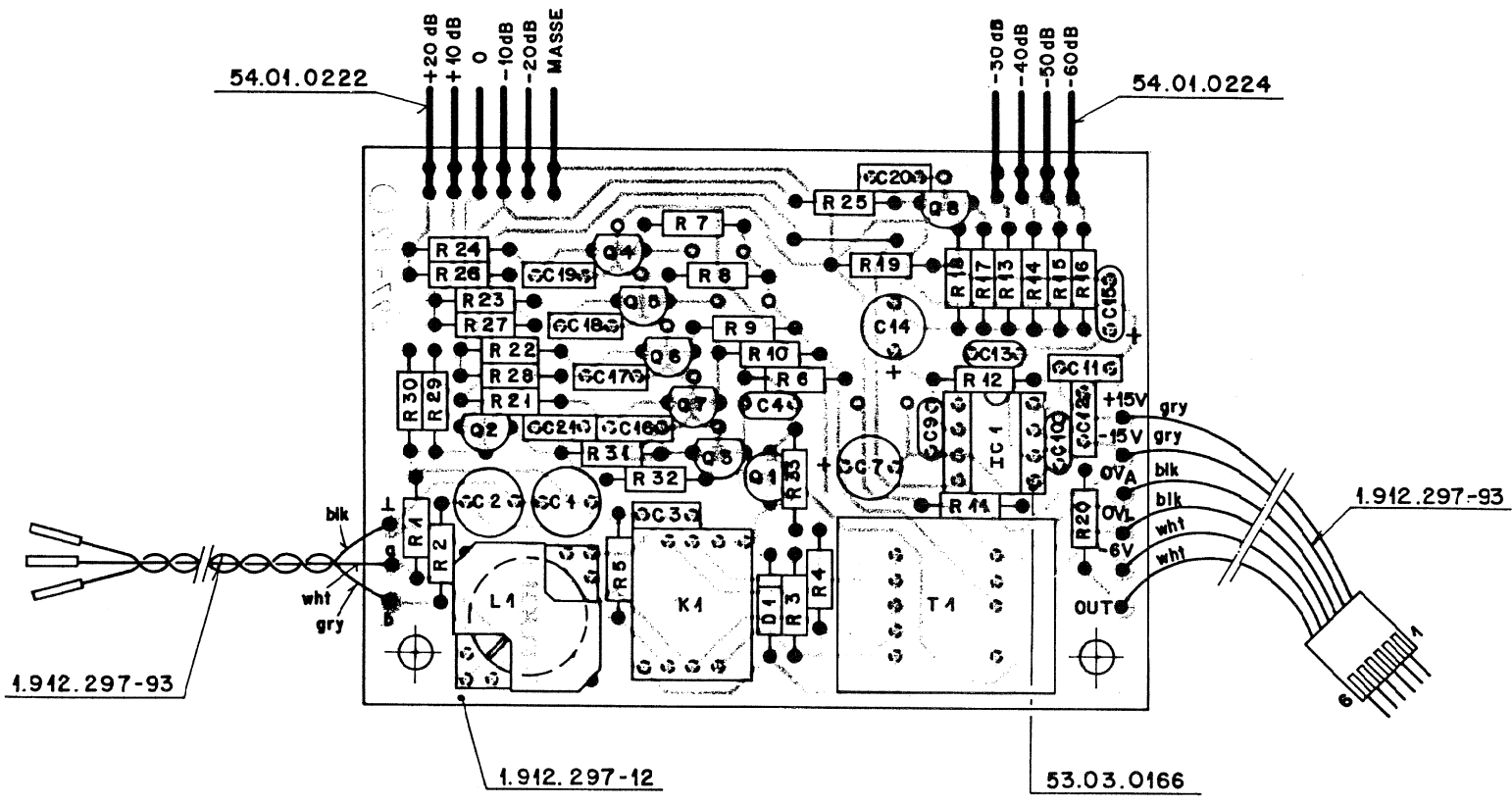

Werkstoff:	Norm-Nr.:	Güte:	Änderung				
	DIN-Bez.:		Oberfläche:				③
Abmessung:		Beh.:					②
Zugehörige Unterlagen:	Freiinspektanz:	Maßstab:	7.6.82	Ho	Gepr.	Gez.	①
PL	±	2:1	Datum	Gez.	Gepr.	Gez.	Index
Ersatz für:	Ersetzt durch:		Kopie für:				
STUDER REGENSDORF ZÜRICH		Benennung: Microphone Amplifier	Nummer: 1.912.297-00				

IND	POS NO	PART NO	VALUE	SPECIFICATIONS/EQUIVALENT	MFR
C	1	59.05.1102	1 n 1%	630V PP	
	2	59.05.1102	1 n 1%	630V PP	
	3	59.06.0102	1 n	63V PE	
	4	59.34.4224	220 p	CER	
	7	59.22.5220	22 μ	16V EL	
	9	59.34.2220	22 p	CER	
	10	59.34.2220	22 p	CER	
	11	59.34.5564	560 p	CER	
	12	59.34.5564	560 p	CER	
	13	59.34.4334	330 p	CER	
	14	59.22.5220	22 μ	16V EL	
	15	59.26.0470	47 μ	63V SAL	
	16	59.06.0682	68 n	63V PE	
	17	59.06.0682	68 n	63V PE	
	18	59.06.0682	68 n	63V PE	
	19	59.06.0682	68 n	63V PE	
	20	59.06.0682	68 n	63V PE	
	21	59.06.0682	68 n	63V PE	
D	1	50.04.0125	1N4448		
IC	1	50.05.0244	NE5534AN	LOW NOISE	
K	1	56.04.0170	5V		

IND	DATE	NAME
④		CER: CERAMIC
③		EL: ELECTROLYTIC
②		PE: POLYESTER
①		PP: POLYPROPYLEN
○	8.4.82	Eckert

STUDER MICROPHONE AMPLIFIER PL 1.912.297.00 PAGE 1 OF 3

IND	POS NO	PART NO	VALUE	SPECIFICATIONS/EQUIVALENT	MFR
L	1	1.022.207.00		HF SYM. COIL	
Q	1	50.03.0515	BC 307		
	2	50.03.0436	BC 237		
	3	50.03.0350	J 112		
	4	50.03.0350	J 112		
	5	50.03.0350	J 112		
	6	50.03.0350	J 112		
	7	50.03.0350	J 112		
	8	50.03.0350	J 112		
R	1	57.11.3103	10 k 1%		
	2	57.11.3103	10 k 1%		
	3	57.11.3432	43 k 1%		
	4	57.11.3432	43 k 1%		
	5	57.11.4452	45 k 5%		
	6	57.11.4423	42 k 5%		
	7	57.11.4824	820 2%		
	8	57.11.3302	3 k 2%		
	9	57.11.4453	45 k 2%		
	10	57.11.4453	45 k 2%		
	11	57.11.4223	22 k		
	12	57.11.4334	330 k 5%		
	13	57.11.4452	45 k 2%		
	14	57.11.3364	360 2%		
	15	57.11.3114	110 2%		

IND	DATE	NAME
④		
③		
②		
①		
○	8.4.82	Eckert

STUDER MICROPHONE AMPLIFIER PL 1.912.297.00 PAGE 2 OF 3

IND	POS NO	PART NO	VALUE	SPECIFICATIONS/EQUIVALENT	MFR
R	16	57.11.4330	33 2%		
	17	57.11.4452	45 k 2%		
	18	57.11.3332	33 k 2%		
	19	57.11.4223	22 k		
	20	57.11.4330	33		
	21	57.11.6106	40 M		
	22	57.11.6106	40 M		
	23	57.11.6106	40 M		
	24	57.11.6106	40 M		
	25	57.11.6106	40 M		
	26	57.11.4404	100 k		
	27	57.11.4404	100 k		
	28	57.11.4404	100 k		
	29	57.11.4404	100 k		
	30	57.11.4404	100 k		
	31	57.11.6106	40 M		
	32	57.11.4223	22 k		
	33	57.11.4404	100 k		
S	1		1p	} COMBINED WITH K1	
	2		1p		
T	1	1.022.447.00		MIC INPUT TRAFD	
XIC		53.03.0466	8p	IC SOCKET	

IND	DATE	NAME
④		
③		
②		
①		
○	8.4.82	Eckert

STUDER MICROPHONE AMPLIFIER PL 1.912.297.00 PAGE 3 OF 3

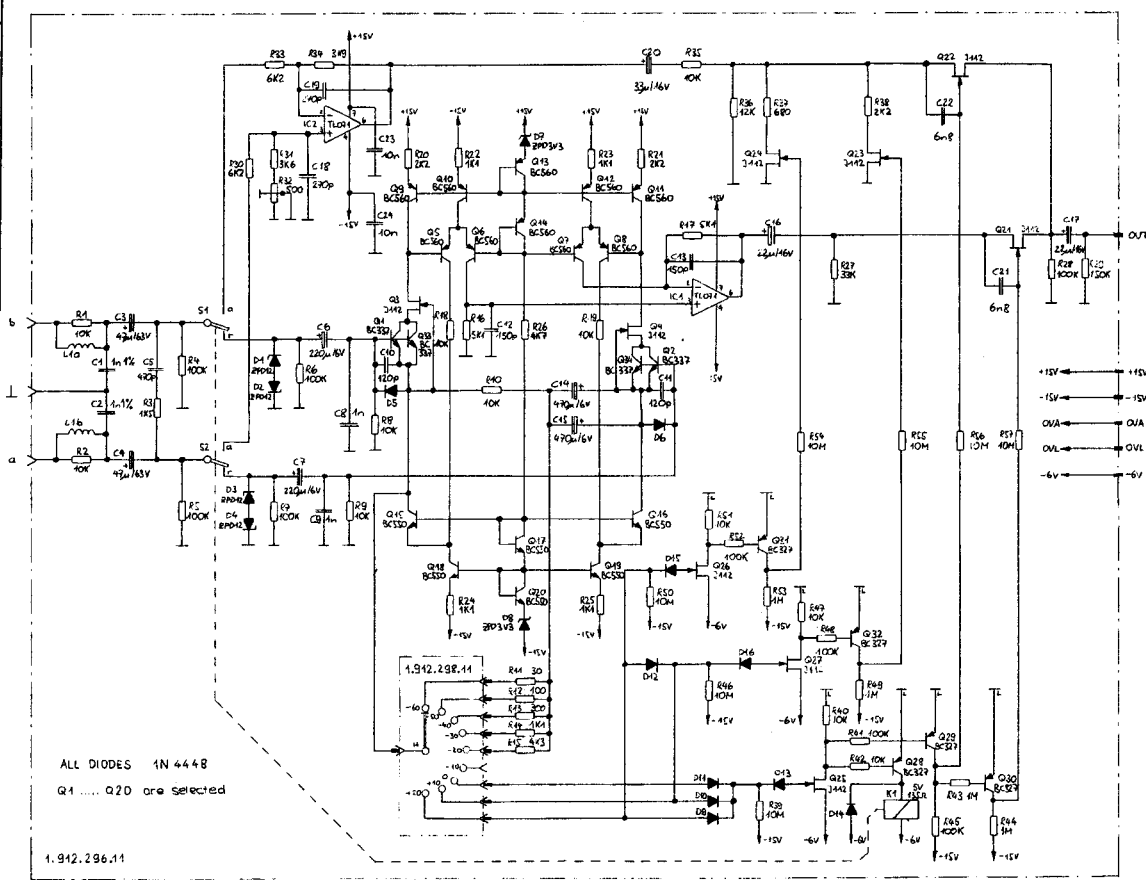

ALL DIODES 1N 4448
 Q1 Q20 are selected

54.01.0222

54.01.0224

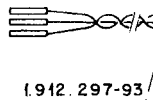

1.912.297-93

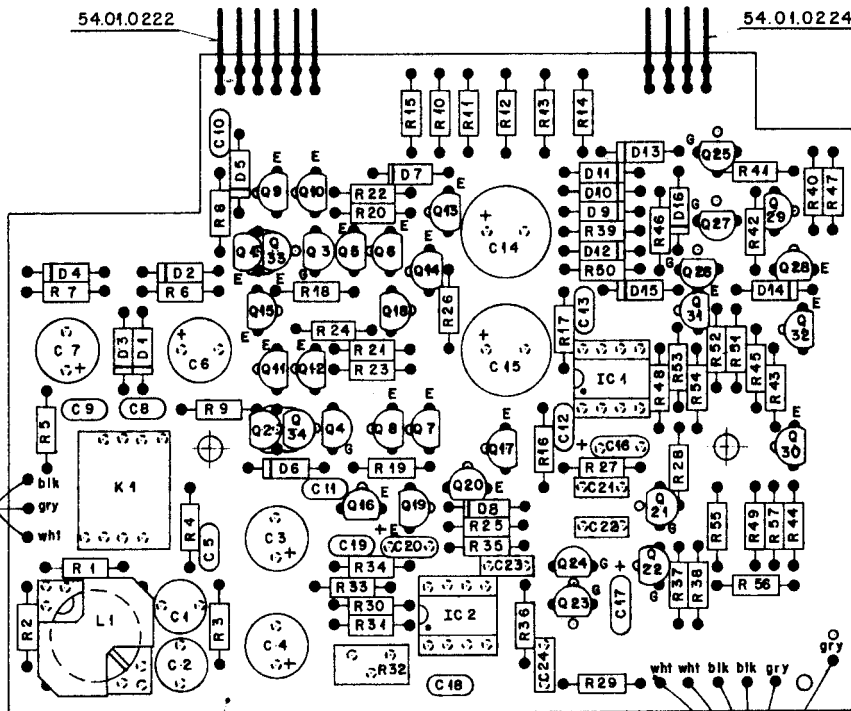

1.912.296-11

1.912.297-93

Ⓐ Q 33 u. Q 34 neu hinzu
D7/D8 umgedreht

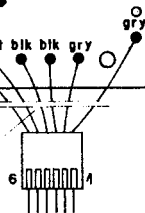

IND	POS NO	PART NO	VALUE	SPECIFICATIONS/EQUIVALENT	MFR
C	1	59.05.1102	1 n	1% 63V PP	
	2	59.05.1102	1 n	1% 63V PP	
	3	59.22.8470	47 M	63V EL	
	4	59.22.8470	47 M	63V EL	
	5	59.34.5471	470 P	CER	
	6	59.22.2224	220 M	6 V EL	
	7	59.22.2224	220 M	6 V EL	
	8	59.06.0102	1 n	PETP	
	9	59.06.0102	1 n	PETP	
	10	59.34.4124	120 P	CER	
	11	59.34.4124	120 P	CER	
	12	59.34.4151	150 P	CER	
	13	59.34.4151	150 P	CER	
	14	59.22.2471	470 M	6 V EL	
	15	59.22.2471	470 M	6 V EL	
	16	59.26.1220	22 M	10V SAL	
	17	59.26.1220	22 M	10V SAL	
	18	59.34.4271	270 P	CER	
	19	59.34.4271	270 P	CER	
	20	59.26.1330	33 M	10V SAL	
	21	59.06.0682	6.8 n	PETP	
	22	59.06.0682	6.8 n	PETP	
	23	59.06.0103	10 n	PETP	
	24	59.06.0103	10 n	PETP	
D	1	50.04.1117	ZPD12		
	2	50.04.1117	ZPD12		
	3	50.04.1117	ZPD12		

IND	DATE	NAME
①		
②		
③		
④		
⑤		
⑥	27.Juli.83	W.Markt
⑦	9.Sept.82	W.Markt

SETUDDER Mic Amp trafoless **PL** 1.912.296.00 PAGE 1 of 6

IND	POS NO	PART NO	VALUE	SPECIFICATIONS/EQUIVALENT	MFR
D	4	50.04.1117	ZPD12		
	5	50.04.0125	1N4448		
	6	50.04.0125	1N4448		
	7	50.04.1102	ZPD3V3		
①	8	50.04.1102	ZPD3V3		
②	9	50.04.0125	1N4448		
	10	50.04.0125	1N4448		
	11	50.04.0125	1N4448		
	12	50.04.0125	1N4448		
	13	50.04.0125	1N4448		
	14	50.04.0125	1N4448		
	15	50.04.0125	1N4448		
	16	50.04.0125	1N4448		
IC	1	50.09.0103	TL071	BI-FET	
	2	50.09.0103	TL071	BI-FET	
K	1	56.04.0170	5V 2-U	100V/Q5A	
L	1	1.027	169.00	HF Sym.Coil	
Q	1	1.010.037.50	BC337	NPN LOW NOISE	
	2	1.010.037.50	BC337	NPN LOW NOISE	
	3	50.03.0350	J112	J-FET	
	4	50.03.0350	J112	J-FET	

IND	DATE	NAME
①		
②		
③		
④		
⑤		
⑥	27.Juli.83	W.Markt
⑦	9.Sept.82	W.Markt

SETUDDER Mic Amp trafoless **PL** 1.912.296.00 PAGE 2 of 6

IND	POS NO	PART NO	VALUE	SPECIFICATIONS/EQUIVALENT	MFR
Q	5	1.010.038.50	BC560	PNP LOW NOISE	
	6	1.010.038.50	BC560	PNP LOW NOISE	
	7	1.010.038.50	BC560	PNP LOW NOISE	
	8	1.010.038.50	BC560	PNP LOW NOISE	
①	9	1.010.038.50	BC560	PNP LOW NOISE	
②	10	1.010.038.50	BC560	PNP LOW NOISE	
③	11	1.010.038.50	BC560	PNP LOW NOISE	
④	12	1.010.038.50	BC560	PNP LOW NOISE	
⑤	13	1.010.038.50	BC560	PNP LOW NOISE	
	14	1.010.038.50	BC560	PNP LOW NOISE	
	15	1.010.039.50	BC550	NPN LOW NOISE	
	16	1.010.039.50	BC550	NPN LOW NOISE	
	17	1.010.039.50	BC550	NPN LOW NOISE	
①	18	1.010.039.50	BC550	NPN LOW NOISE	
②	19	1.010.039.50	BC550	NPN LOW NOISE	
③	20	1.010.039.50	BC550	NPN LOW NOISE	
	21	50.03.0350	J112	J-FET	
	22	50.03.0350	J112	J-FET	
	23	50.03.0350	J112	J-FET	
	24	50.03.0350	J112	J-FET	
	25	50.03.0350	J112	J-FET	
	26	50.03.0350	J112	J-FET	
	27	50.03.0350	J112	J-FET	
	28	50.03.0351	BC327	PNP	
	29	50.03.0351	BC327	PNP	
	30	50.03.0351	BC327	PNP	
	31	50.03.0351	BC327	PNP	
	32	50.03.0351	BC327	PNP	
①	33	1.010.037.50	BC337	NPN LOW NOISE	
②	34	1.010.037.50	BC337	NPN LOW NOISE	

IND	DATE	NAME
①		
②		
③		
④		
⑤		
⑥	27.Juli.83	W.Markt
⑦	10.Sept.82	W.Markt

SETUDDER Mic Amp trafoless **PL** 1.912.296.00 PAGE 3 of 6

IND	POS NO	PART NO	VALUE	SPECIFICATIONS/EQUIVALENT	MFR
R	1	57.11.4103	10 K	2 % MF	
	2	57.11.4103	10 K	2 % MF	
	3	57.11.4152	1,5 K	2 % MF	
	4	57.11.4104	100 K		
	5	57.11.4104	100 K		
	6	57.11.4104	100 K		
	7	57.11.4104	100 K		
	8	57.11.4103	10 K		
	9	57.11.4103	10 K		
	10	57.11.4103	10 K	2 % MF	
	11	57.11.3300	30	2 % MF	
	12	57.11.3101	100	2 % MF	
	13	57.11.3304	300	2 % MF	
	14	57.11.3112	1,1 K	2 % MF	
	15	57.11.3432	4,3 K	2 % MF	
	16	57.11.3512	5,1 K	2 % MF	
	17	57.11.3512	5,1 K	2 % MF	
	18	57.11.4103	10 K		
	19	57.11.4103	10 K		
①	20	57.11.4222	2,2 K	2 % MF	
②	21	57.11.4222	2,2 K	2 % MF	
③	22	57.11.3112	1,1 K	2 % MF	
④	23	57.11.3112	1,1 K	2 % MF	
⑤	24	57.11.3112	1,1 K	2 % MF	
⑥	25	57.11.3112	1,1 K	2 % MF	
	26	57.11.4472	4,7 K		
	27	57.11.4333	33 K		
	28	57.11.4104	100 K		
	29	57.11.4154	150 K		
	30	57.11.3622	6,2 K	2 % MF	

IND	DATE	NAME
①		
②		
③		
④		
⑤		
⑥	27.Juli.83	W.Markt
⑦	10.Sept.82	W.Markt

SETUDDER Mic Amp trafoless **PL** 1.912.296.00 PAGE 4 of 6

IND	POS NO	PART NO	VALUE	SPECIFICATIONS/EQUIVALENT	MFR
R3	1	57.11.3362	3,6 K	2 % MF	
	32	58.01.2501	500	TRIM	MG
	33	57.11.3622	6,2 K	2 % MF	
	34	57.11.4382	3,9 K	2 % MF	
	35	57.11.4103	10 K	2 % MF	
	36	57.11.4123	12 K	2 % MF	
	37	57.11.3681	680	2 % MF	
	38	57.11.4222	2,2 K	2 % MF	
	39	57.11.6106	10 M		
	40	57.11.4103	10 K		
	41	57.11.4104	100 K		
	42	57.11.4103	10 K		
	43	57.11.4105	1 M		
	44	57.11.4105	1 M		
	45	57.11.4104	100 K		
	46	57.11.6106	10 M		
	47	57.11.4103	10 K		
	48	57.11.4104	100 K		
	49	57.11.4105	1 M		
	50	57.11.6106	10 M		
	51	57.11.4103	10 K		
	52	57.11.4104	100 K		
	53	57.11.4105	1 M		
	54	57.11.6106	10 M		
	55	57.11.6106	10 M		
	56	57.11.6106	10 M		
	57	57.11.6106	10 M		

IND	DATE	NAME
①		
②		
③		
④		
⑤		
⑥	27.Juli.83	W.Markt
⑦	10.Sept.82	W.Markt

SETUDDER Mic Amp trafoless **PL** 1.912.296.00 PAGE 5 of 6

IND	POS NO	PART NO	VALUE	SPECIFICATIONS/EQUIVALENT	MFR
S	1		1p	KOMBINED WITH K1	
	2		1p	KOMBINED WITH K1	
XIC	53	03.0166	8p	IC-SOCKET	
①	27.7.83	Improvement of the S/N Ratio			

IND	DATE	NAME
①		
②		
③		
④		
⑤		
⑥	27.Juli.83	W.Markt
⑦	10.Sept.82	W.Markt

SETUDDER Mic Amp trafoless **PL** 1.912.296.00 PAGE 6 of 6

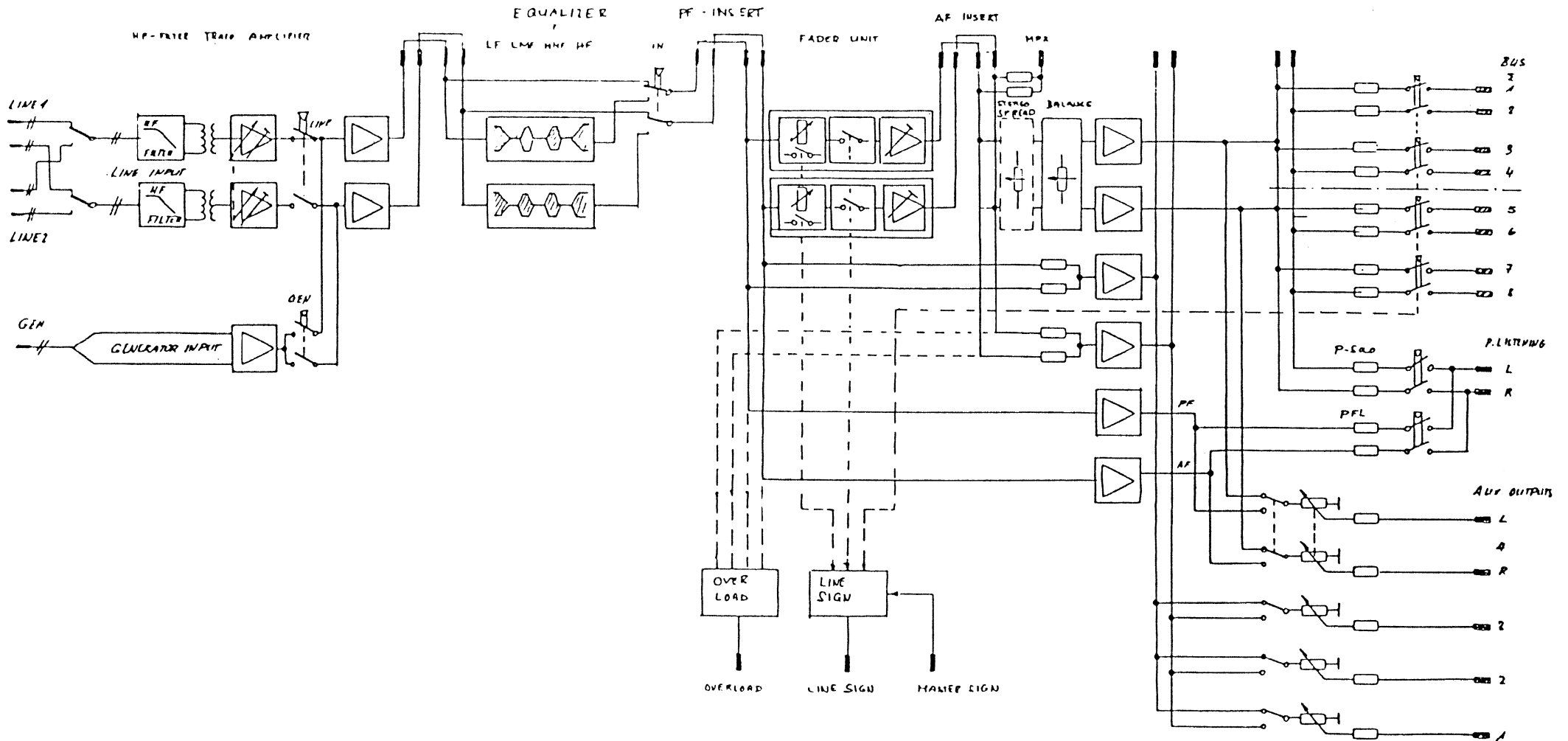

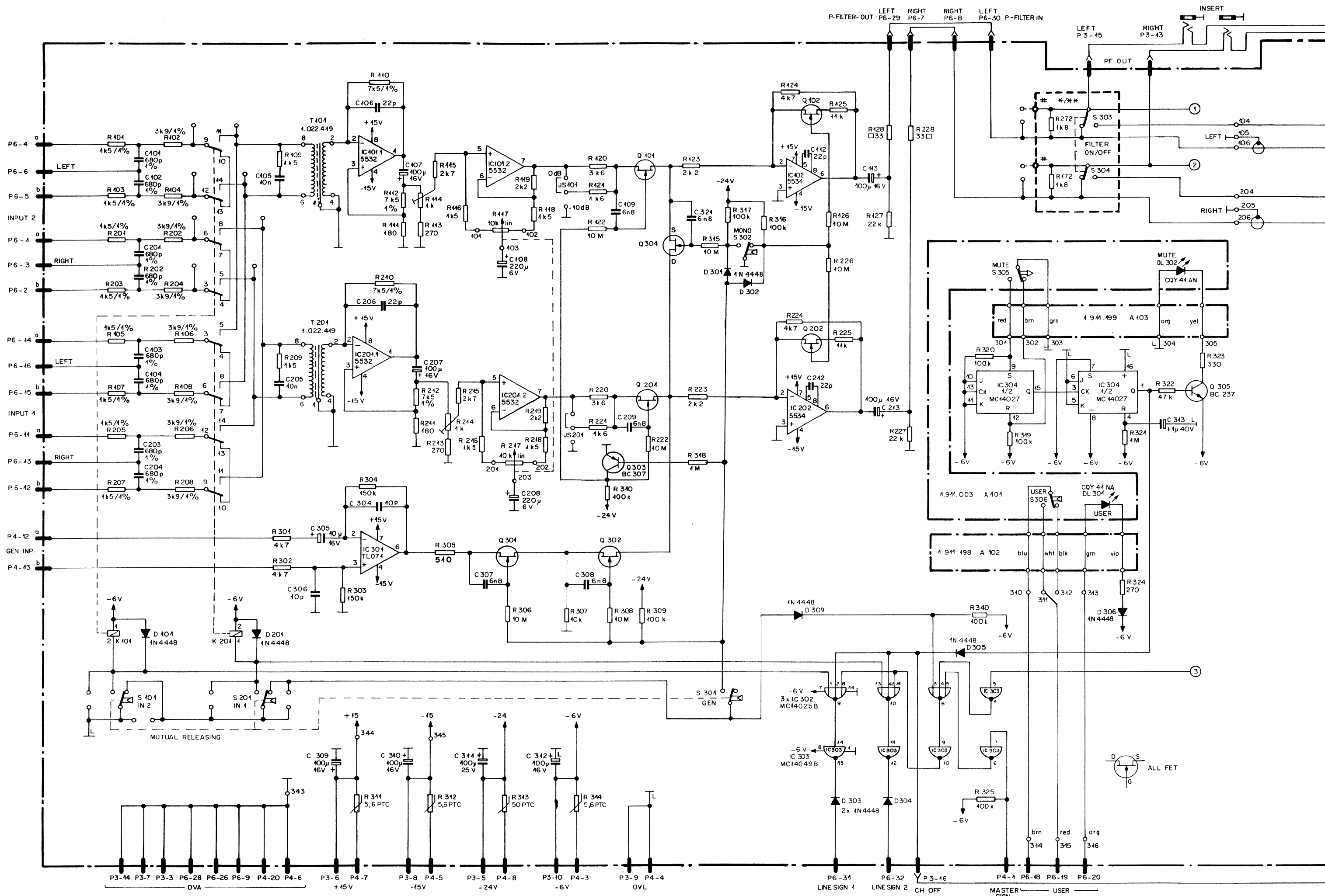

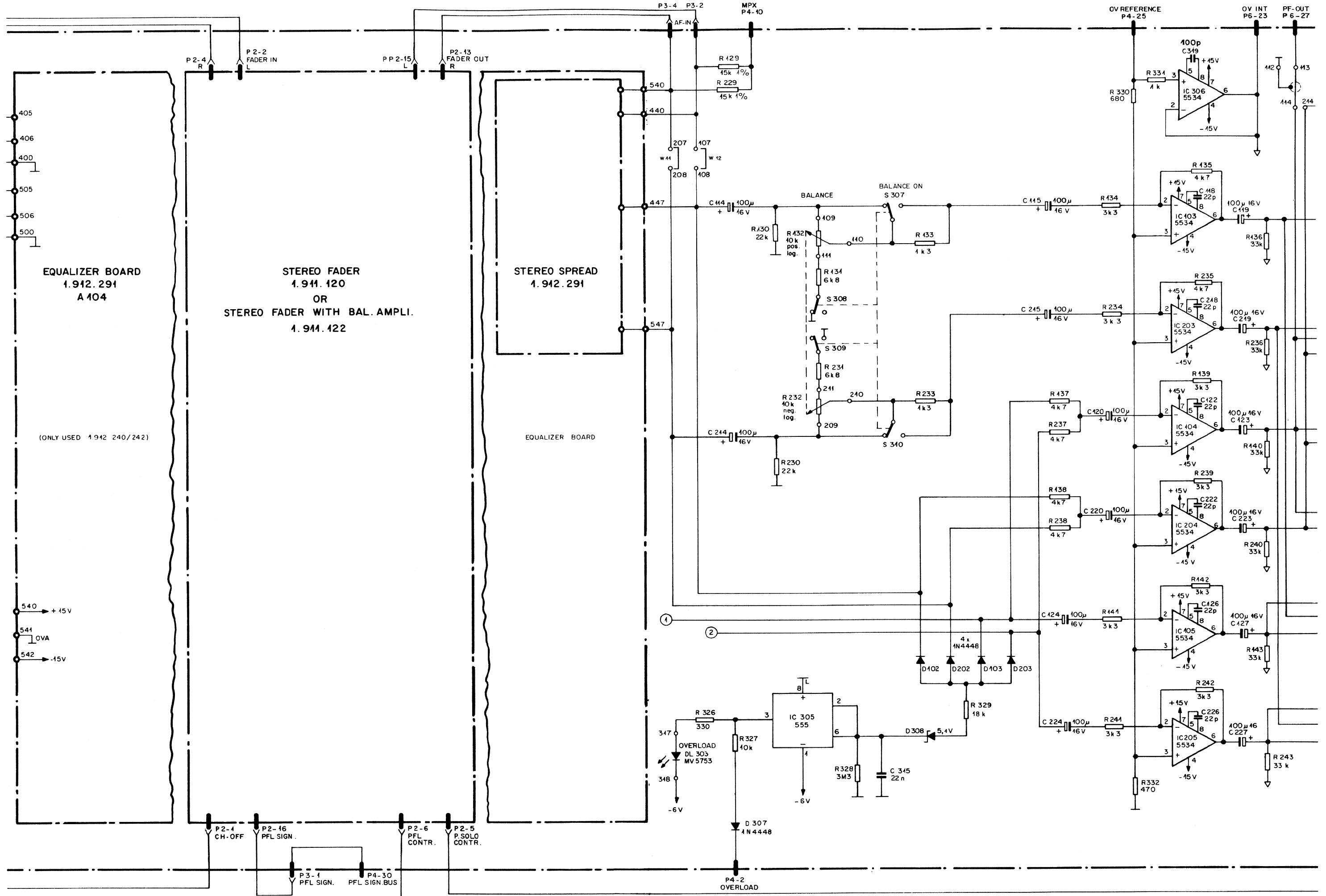

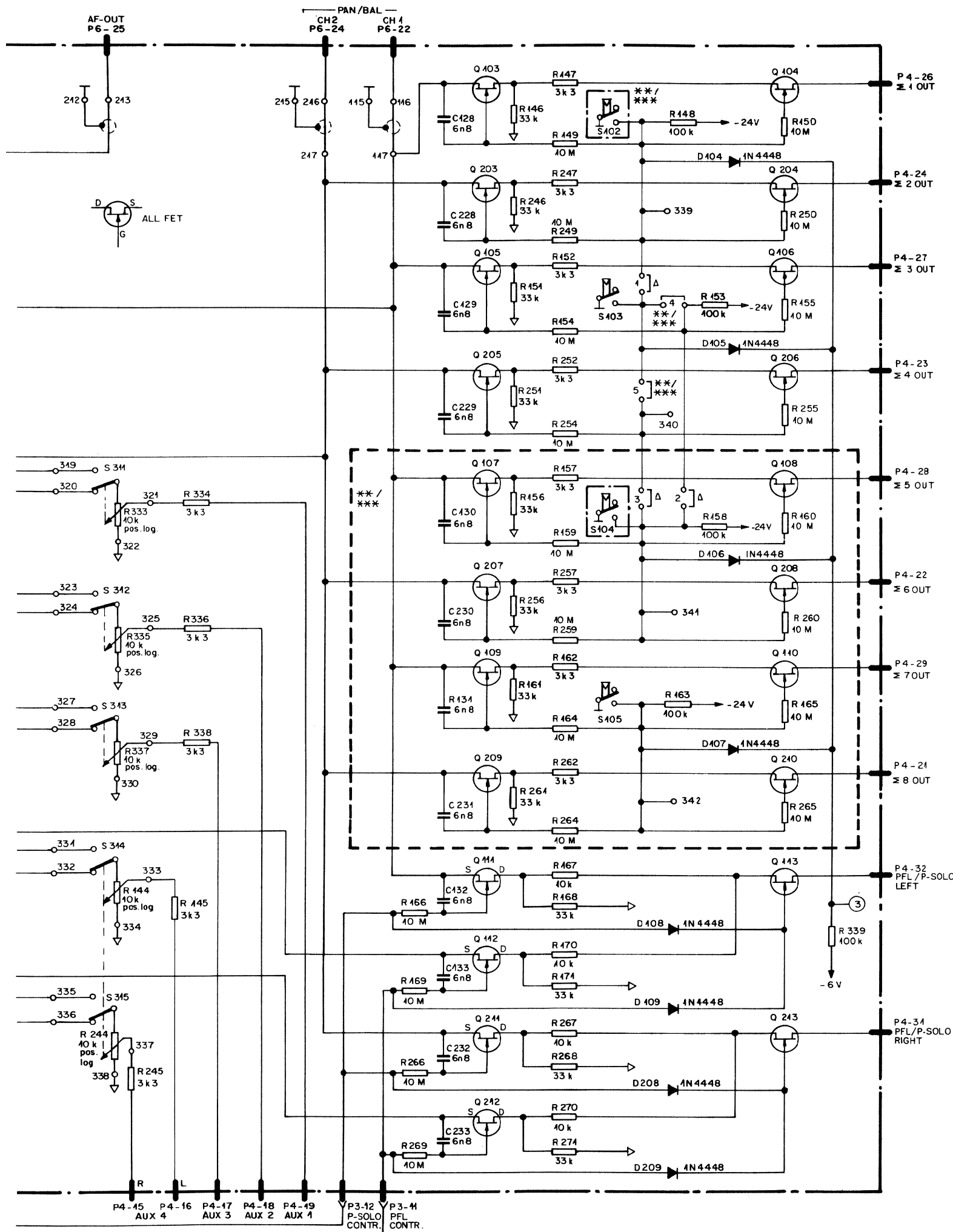

- P 6**
- 1 LINE a
 - 2 LINE b
 - 3 SCREEN
 - 4 LINE a
 - 5 LINE b
 - 6 SCREEN
 - 7 P-FILTER OUT
 - 8 P-FILTER IN
 - 9 OVA
 - 10 X
 - 11 LINE a
 - 12 LINE b
 - 13 SCREEN
 - 14 LINE a
 - 15 LINE b
 - 16 SCREEN
 - 17 X
 - 18 USER
 - 19 USER
 - 20 USER
 - 21 X
 - 22 CH 1 PAN/BAL
 - 23 DV INT.
 - 24 CH 2 PAN/BAL
 - 25 AF OUT
 - 26 OVA
 - 27 PF-OUT
 - 28 OVA
 - 29 P-FILTER OUT
 - 30 P-FILTER IN
 - 31 LINE SIGN. 1
 - 32 LINE SIGN. 2

- P 4**
- 1 MASTER SIGN.
 - 2 OVERLOAD
 - 3 -6V
 - 4 OVL
 - 5 -15V
 - 6 OVA
 - 7 +15V
 - 8 -24V
 - 9 X
 - 10 MPX
 - 11 X
 - 12 GEN. a
 - 13 GEN. b
 - 14 X
 - 15 AUX 4-R OUT
 - 16 AUX 4-L OUT
 - 17 AUX 3 OUT
 - 18 AUX 2 OUT
 - 19 AUX 1 OUT
 - 20 OVA
 - 21 ≥ 8 OUT
 - 22 ≥ 6 OUT
 - 23 ≥ 4 OUT
 - 24 ≥ 2 OUT
 - 25 OV REF
 - 26 ≥ 1 OUT
 - 27 ≥ 3 OUT
 - 28 ≥ 5 OUT
 - 29 ≥ 7 OUT
 - 30 PFL - SIGN. BUS
 - 31 PFL/P-SOLO R
 - 32 PFL/P-SOLO L

- P 3**
- 1 PFL-SIGN. BUS
 - 2 FADER OUT L
 - 3 OVA R
 - 4 FADER OUT R
 - 5 -24V
 - 6 +15V
 - 7 OVA
 - 8 -15V
 - 9 OVL
 - 10 X
 - 11 -6V
 - 12 PFL CONTR.
 - 13 OVA
 - 14 +15V
 - 15 -24V
 - 16 FADER IN R
 - 17 OVA L
 - 18 FADER IN L
 - 19 CH-OFF

- P 2**
- 1 CH-OFF
 - 2 FADER IN L
 - 3 OVA L
 - 4 FADER IN R
 - 5 P-SOLO CONTR.
 - 6 PFL CONTR.
 - 7 -6V
 - 8 OVL
 - 9 -15V
 - 10 OVA
 - 11 +15V
 - 12 -24V
 - 13 FADER OUT R
 - 14 OVA R
 - 15 FADER OUT L
 - 16 PFL-SIGN. BUS

Q 101, 201 = J 111
 Q 102 113
 Q 202 213 J 112
 Q 301, 302, 304

* 4 CH FILTER : 1.912.240
 4 CH : 1.912.241
 ** 8 CH FILTER : 1.912.242
 *** 8 CH : 1.912.243

Δ 8 CH VERSION NOT EQUIPPED
 □ FILTER VERSION REPLACED BY LINK
 # WITHOUT FILTER " " "

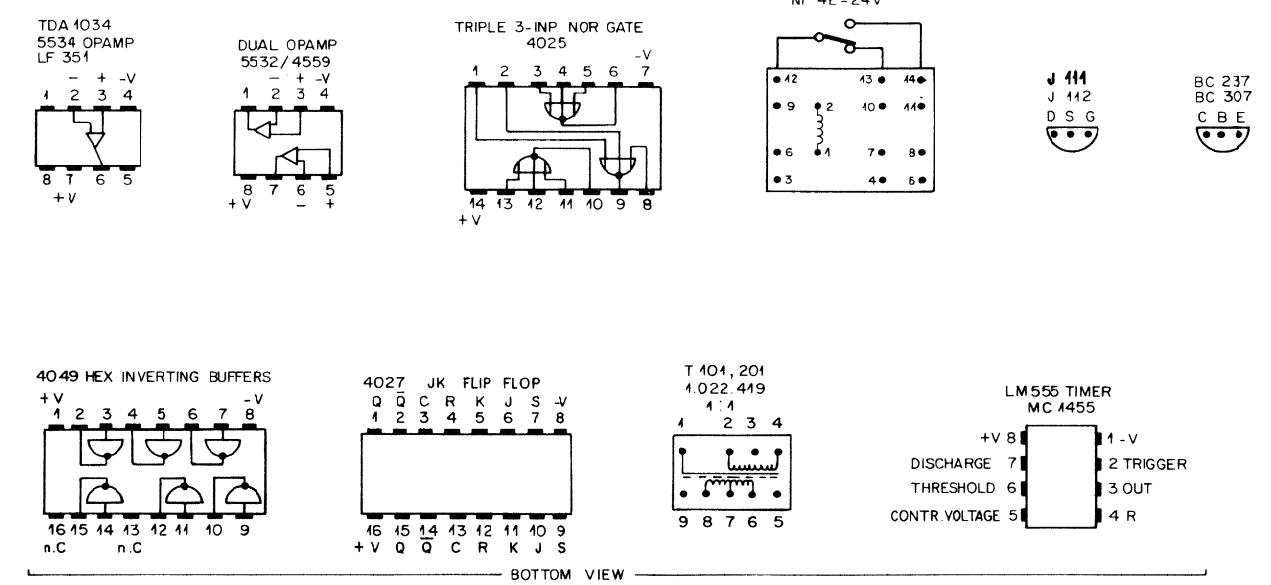

DATE	11.12.84	11.4.85				
SIGN	ml	ml				
DATE	9.5.83	26.2.84	11.5.84	6.9.84	4.10.84	
SIGN	ml	ml	ml	ml	ml	PAGE 3 OF 3
STUDER REGENSDORF ZURICH		HL STEREO INPUT UNIT A 4 CH/FILTER				1.912.240...243

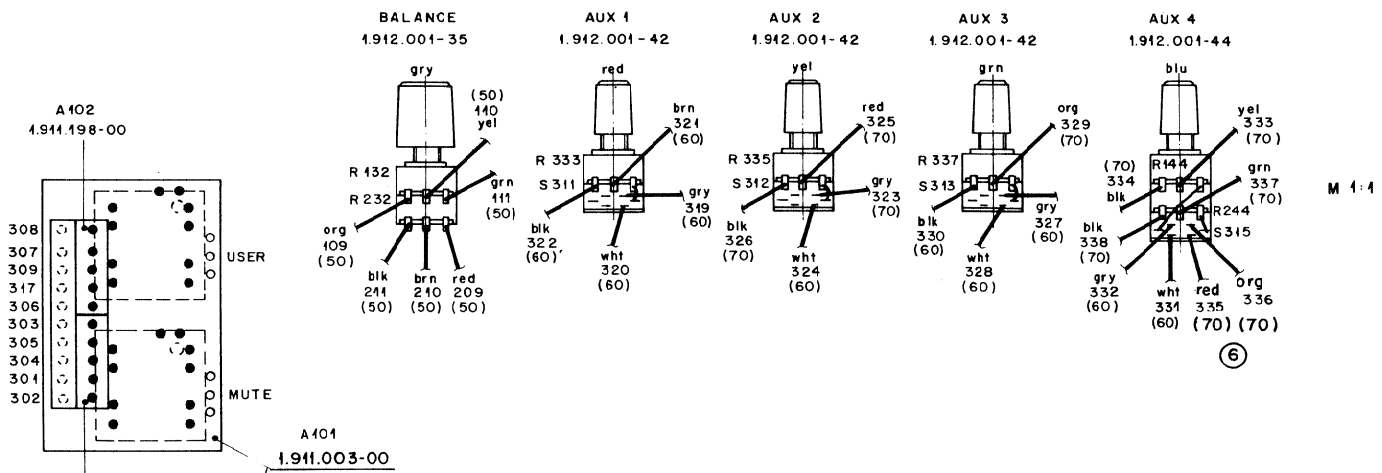

⑤

WIRINGDIAGRAM FOR FILTER VERSION

UNIT	EQ BOARD			
1.912.240-00	1.912.291-00			
104	405	gry	FILTER OUT	L
105	400	blk	⊥	L
106	406	wht	FILTER IN	L
107	441	grn	SPREAD IN	L
108	446	gry	SPREAD OUT	L
204	505	brn	FILTER OUT	R
205	500	blk	⊥	R
206	506	wht	FILTER IN	R
207	541	wht	SPREAD IN	R
208	546	brn	SPREAD OUT	R
343	541	blk	OV	
344	540	red	+45 V	
345	542	blu	-45 V	

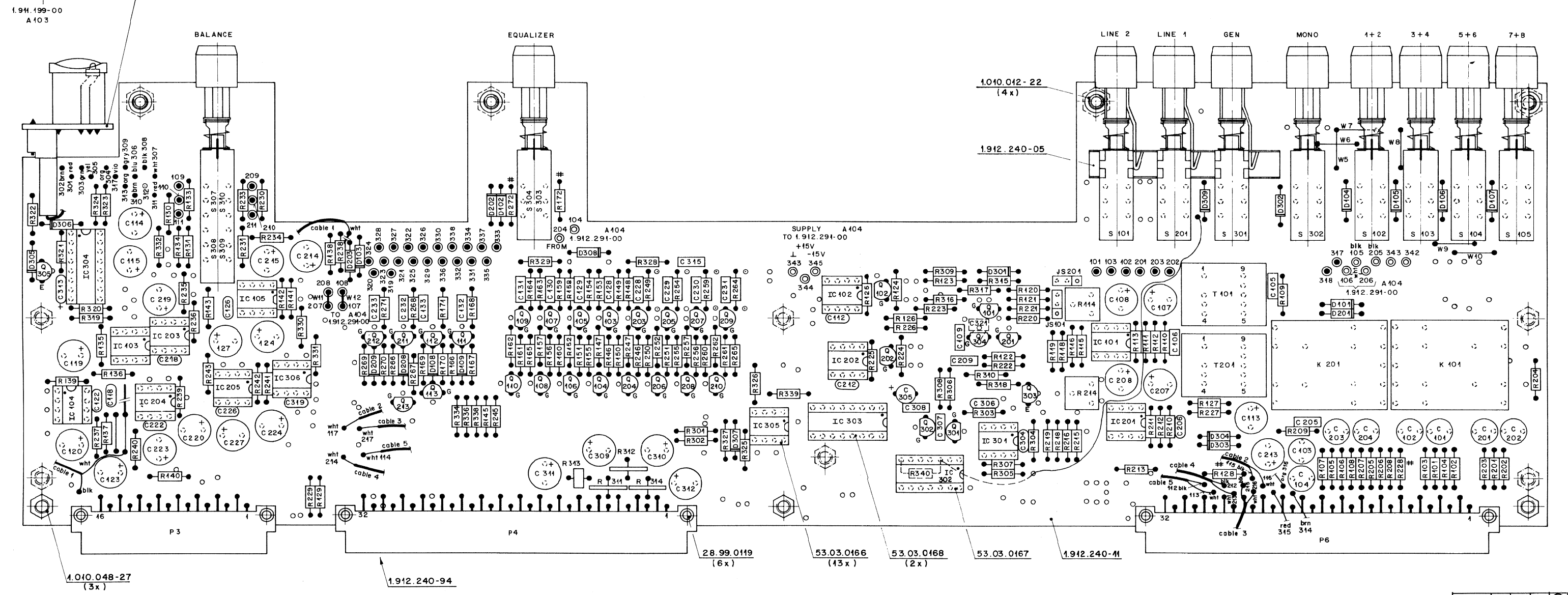
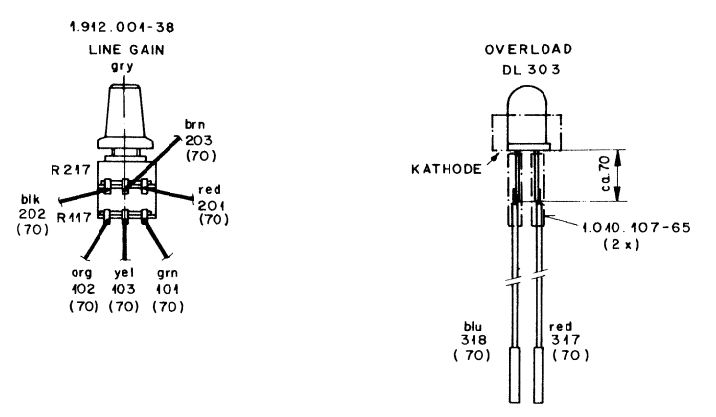

④ # In der Version mit Filter (1.912.240/242-00) müssen R172/R272 (1k Ω) bestückt werden. R128/R228 müssen durch Brücken ersetzt werden.

In der Version ohne Filter (1.912.241/243-00) müssen R172/R272 durch Brücken ersetzt werden. R128/R228 (33 Ω) müssen bestückt werden.

// Leiterbahn auf Bestückungsseite aufgetrennt

FILTER VERSION : R172 REPLACED (OPTION 1)

W1	R272	"
W2	W3	"
W4	W4	"

ONLY 4CH : W5, W6, W10
 ONLY 8CH : W6, W7, W9
 W6 ONLY USED WITH PCB 1.912.240-11 INDEX 0

④ // CIRCUIT INTERRUPT COMPONENTSIDE

VALID FOR	NR. UNIT	PL	EQUALIZER
4CH FILTER	1.912.240-00	1.912.240-00	1.912.291-00
4CH	1.912.241-00	1.912.240-00	—
8CH FILTER	1.912.242-00	1.912.240-00	1.912.291-00
8CH	1.912.243-00	1.912.240-00	—

Norm-Nr.:	Güte:	28.885	A.Ho	⑥
DIN-Bez.:	Beh.:	M.4.85	A.Ho	⑤
Abmessung:	Änderung:	11.12.84	A.Ho	④
Zugehörige Unterlagen:	Freimasstoleranz:	6.9.84	R.Be	③
*	±	9.2.84	A.Ho	②
Ersetzt durch:	Maßstab:	23.9.83	A.Ho	①
	1:1, 2:1	Datum	Gez.	①
		Gepr.	Ges.	
Ersetzt durch:	Kopie für:			
STUDER REGENSDORF ZÜRICH	Benennung:	HL Stereo Input Unit 4CH / 8CH		Nr.:
				1.912.240-00

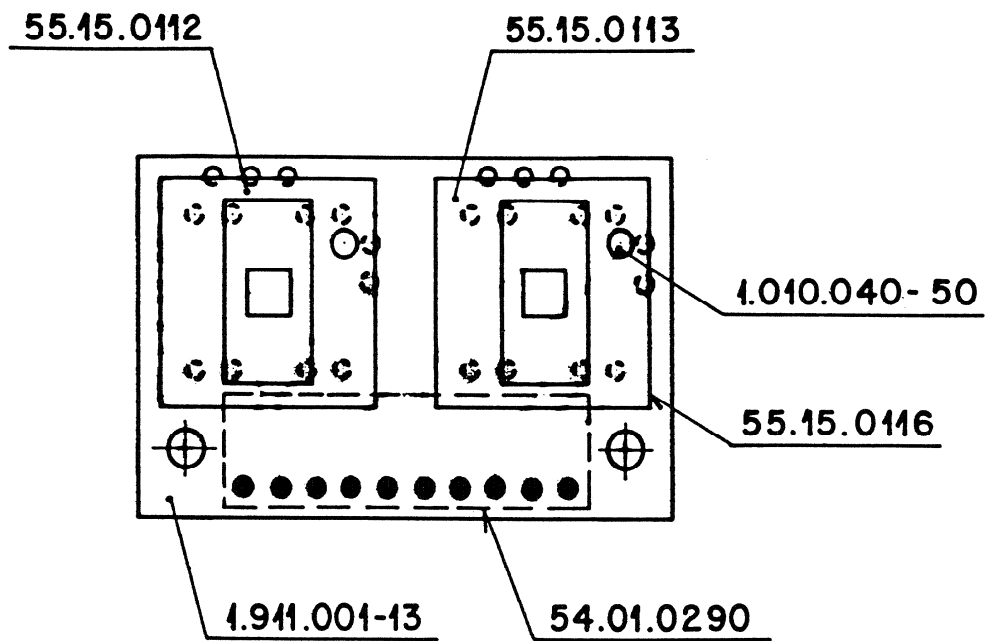

Werkstoff	Norm-Nr.:	Oberfläche	Güte:					③
	DIN-Bez.:		Beh.:					②
	Abmessung:						①	
Zugehörige Unterlagen:		Freimasstoleranz:	Maßstab:	19.5.82	Ho	W		⑤
		±	2:1	Datum	Gez.	Gepr.	Ges.	Index
Ersatz für:		Ersetzt durch:		Kopie für:				
STUDER REGENSDORF ZÜRICH		Bezeichnung: Pushbutton Board N-L		Nummer: 1.911.003-00				

IND	POS NO	PART NO	VALUE	SPECIFICATIONS/EQUIVALENT	MFR
	A101	1.911.003.00		PUSHBUTTON BOARD	ST
	102	1.911.198.00		CONNECTING CABLE 2	"
	103	1.911.199.00		" " 1	"
1	104	1.912.291.00		EQUALIZER BOARD OPTION 1	"

IND	POS NO	PART NO	VALUE	SPECIFICATIONS/EQUIVALENT	MFR
	C.01	59.05.1681	680 p	1% 500V PP	
	.02	59.05.1681	680 p	1% 500V PP	
	.03	59.05.1681	680 p	1% 500V PP	
	.04	59.05.1681	680 p	1% 500V PP	
	.05	59.06.0103	10 n	10% 63V PE	
	.06	59.34.2220	22 p	CER	
	.07	59.22.4101	100 μ	16V EL	
	.08	59.22.2221	220 μ	63V EL	
	.09	59.06.0682	6,8 n	63V PE	
	.12	59.34.2220	22 p	CER	
	.13	59.22.4101	100 μ	16V EL	
	.14	59.22.4101	100 μ	16V "	
	.15	59.22.4101	100 μ	16V "	
	.18	59.34.2220	22 p	CER	
	.19	59.22.4101	100 μ	16V EL	
	.20	59.22.4101	100 μ	16V EL	
	.22	59.34.2220	22 p	CER	
	.23	59.22.4101	100 μ	16V EL	
	.24	59.22.4101	100 μ	16V EL	
	.26	59.34.2220	22 p	CER	
	.27	59.22.4101	100 μ	16V EL	
	.28	59.06.0682	6,8 n	10% 63V PE	
	.29	59.06.0682	6,8 n	" " "	
1	.30	59.06.0682	6,8 n	" " " *	

IND	DATE	NAME		
④	11.12.84	⑤ 11.4.85 1/2	OPTION 1	4CH/FILTER: 1.912.240.00
③	4.10.84	1/2	with Filter	4CH : 1.912.241.00
②	11.5.84	1/2		8CH/FILTER: 1.912.242.00
①	9.2.84	1/2		8CH : 1.912.243.00
○	12.6.82	TAMAS 1/2	ST: STUDER	

STUDER HL ST INPUT UNIT 4CH/FILTER PL 1.912.240.00 PAGE 1 OF 13

IND	DATE	NAME		
④	11.12.84	⑤ 11.4.85 1/2	CER : CERAMIC	
③	4.10.84	1/2	EL : ELECTROLYTIC	
②	11.5.84	1/2	PE : POLYESTER	
①	9.2.84	1/2	PP : POLYPROPYLEN	* only 8 CH
○	12.6.82	TAMAS 1/2		

STUDER HL ST INPUT UNIT 4CH/FILTER PL 1.912.240.00 PAGE 2 OF 13

IND	POS NO	PART NO	VALUE	SPECIFICATIONS/EQUIVALENT	MFR
1	C.31	59.06.0682	6,8 n	63V PE *	
	.32	59.06.0682	6,8 n	63V PE	
	.33	59.06.0682	6,8 n	63V PE	
	C304	59.34.1100	10 p	CER	
	305	59.30.4100	10 μ	16V EL	
	306	59.34.1100	10 p	CER	
	307	59.06.0682	6,8 n	63V PE	
	308	59.06.0682	6,8 n	63V PE	
	309	59.22.4101	100 μ	16V EL	
	310	59.22.4101	100 μ	" "	
	311	59.22.5101	100 μ	25V "	
	312	59.22.4101	100 μ	16V "	
	313	59.26.9109	1 μ	6V SAL	
	315	59.06.0223	22 n	63V PE	
3	319	59.34.4101	100 p	CER	
2	321	59.06.0682	6,8 n	63V PE	

IND	POS NO	PART NO	VALUE	SPECIFICATIONS/EQUIVALENT	MFR
	D.01	50.04.0125	1N4448		
	.02	50.04.0125	1N4448		
	.03	50.04.0125	1N4448		
1	104	50.04.0125	1N4448		*
	105	50.04.0125	1N4448		
	106	50.04.0125	1N4448		
1	107	50.04.0125	1N4448		*
	.08	50.04.0125	1N4448		
	.09	50.04.0125	1N4448		
	D301	50.04.0125	1N4448		
	302	50.04.0125	1N4448		
	303	50.04.0125	1N4448		
	304	50.04.0125	1N4448		
	305	50.04.0125	1N4448		
	306	50.04.0125	1N4448		
	307	50.04.0125	1N4448		
	308	50.04.1112	Z 5V1	400mW	
	309	50.04.0125	1N4448		
	D301	1.010.040.50	COY 41 NA		ST
	302	1.010.040.50	COY 41 NA		ST
	303	50.04.2111	MV 5753		

IND	DATE	NAME		
④	11.12.84	⑤ 11.4.85 1/2	CER : CERAMIC	
③	4.10.84	1/2	EL : ELECTROLYTIC	
②	11.5.84	1/2	PE : POLYESTER	
①	9.2.84	1/2	SAL : SOLID ALUMINILUM	* only 8CH
○	12.6.82	TAMAS 1/2		

STUDER HL ST INPUT UNIT 4CH/FILTER PL 1.912.240.00 PAGE 3 OF 13

IND	DATE	NAME		
④	11.12.84	⑤ 11.4.85 1/2	ST : STUDER	
③	4.10.84	1/2		
②	11.5.84	1/2		
①	9.2.84	1/2		
○	12.6.82	TAMAS 1/2		

STUDER HL ST INPUT UNIT 4CH/FILTER PL 1.912.240.00 PAGE 4 OF 13

IND	POS NO	PART NO	VALUE	SPECIFICATIONS/EQUIVALENT	MFR
	IC .01	50.09.0106	NE 5532	LN DUAL OP-AMP	SIG
	.02	50.05.0243	NE 5534	OP-AMP	"
	.03	50.05.0243	NE 5534	"	"
	.04	50.05.0243	NE 5534	"	"
	.05	50.05.0243	NE 5534	"	"
	IC 301	50.09.0103	TL 071	FET OP-AMP LF 351	TI
	302	50.07.0012	4025	3-IN NOR GATE MOS	MOT,FC
	303	50.07.0049	4049	HEX INV. BUFFER MOS	" "
	304	50.07.0027	4027	DUAL J-K FF MOS	" "
	305	50.05.0156	555	TIMER	SIG,NE
	306	50.05.0243	NE 5534	OP-AMP	SIG
	JS .01	54.01.0020	PIN		
		54.01.0021	JUMPER		
	K .01	56.04.0146	NF-4E-6V		
	P 3	54.11.2007	2 * 8	1/2 ELURO B-TYPE	BU
	4	54.01.0359	2 * 16	ELURO B-TYPE	"
	6	54.01.0359	2 * 16	ELURO B-TYPE	"

IND	DATE	NAME		
①	11.12.84	⑤ 11.4.85	SIG : SIGNETICS	BU: BURNDY
③	4.10.84	④	TI : TEXAS INSTRUMENT	
②	11.5.84	⑥	MOT: MOTOROLA	LN: LOW NOISE
①	9.2.84	⑦	FC : FAIRCHILD	
○	21.6.82	TAMAS	NS : NATIONAL SEMICONDUCTORS	
STUDER HL ST INPUT UNIT 4CH/FILTER PL 1.912.240.00 PAGE 5 OF 13				

IND	POS NO	PART NO	VALUE	SPECIFICATIONS/EQUIVALENT	MFR
5	Q .01	50.03.0216	J 111		SX
	.02	50.03.0350	J 112		"
	.03	50.03.0350	J 112		"
	.04	50.03.0350	J 112		"
	.05	50.03.0350	J 112		"
	.06	50.03.0350	J 112		"
1	.07	50.03.0350	J 112		*
1	.08	50.03.0350	J 112		*
1	.09	50.03.0350	J 112		*
1	.10	50.03.0350	J 112		*
	.11	50.03.0350	J 112		"
	.12	50.03.0350	J 112		"
	.13	50.03.0350	J 112		"
	Q 301	50.03.0350	J 112		Sx
	302	50.03.0350	J 112		Sx
	303	50.03.0515	BC 307	PNP	BC 557
	304	50.03.0350	J 112		Sx
	305	50.03.0436	BC 237	NPN	BC 547

IND	DATE	NAME		
①	11.12.84	⑤ 11.4.85	SX : SILICONIX	
③	4.10.84	④		
②	11.5.84	⑥		
①	9.2.84	⑦		
○	21.6.82	TAMAS		* only 8CH
STUDER HL ST INPUT UNIT 4CH/FILTER PL 1.912.240.00 PAGE 6 OF 13				

IND	POS NO	PART NO	VALUE	SPECIFICATIONS/EQUIVALENT	MFR
	R .01	57.11.3152	15 k	1%	
	.02	.3392	39 k	1%	
	.03	.3152	45 k	1%	
	.04	.3392	39 k	1%	
	.05	.3152	45 k	1%	
	.06	.3392	39 k	1%	
	.07	.3152	45 k	1%	
	.08	.3392	39 k	1%	
	.09	.4152	45 k	2%	
	.10	.3752	75 k	2%	
	.11	.4181	180 Ω	2%	
	.12	.3752	75 k	2%	
	.13	.4271	270 Ω		
	.14	58.01.8102	1 k	TRIM	
	.15	57.11.4272	27 k		
	.16	57.11.4152	45 k		
	.17	1.912.001.32	10 k	2 x 10k LIN POT	ST
	.18	57.11.4152	45 k		
	.19	.4222	22 k		
	.20	.3362	36 k	2%	
	.21	.3162	45 k	2%	
5	.22	.5106	10 M		
	.23	.4222	22 k		
	.24	.4472	47 k		
	.25	.3113	45 k	2%	
5	.26	.5106	10 M		
	.27	.4223	22 k		
1	.28	.4330	33 Ω	OPTION 1 replaced by link	
	.29	.4153	45 k		
	.30	.4223	22 k		

IND	DATE	NAME		
①	11.12.84	⑤ 11.4.85	ST : STUDER	
③	4.10.84	④		
②	11.5.84	⑥	OPTION 1 with Filter	
①	9.2.84	⑦		
○	21.6.82	TAMAS		
STUDER HL ST INPUT UNIT 4CH/FILTER PL 1.912.240.00 PAGE 7 OF 13				

IND	POS NO	PART NO	VALUE	SPECIFICATIONS/EQUIVALENT	MFR
	R .31	57.11.4682	68 k		
	.132	1.912.001.35	10 k	POS. LOG. } POT	ST
	.232		10 k	NEG. LOG. }	
	.33	57.11.3132	1,3 k		
	.34	.4332	33 k		
	.35	.4472	47 k		
	.36	.4333	33 k		
	.37	.4472	47 k		
	.38	.4472	47 k		
	.39	.4332	33 k		
	.40	.4333	33 k		
	.41	.4332	33 k		
	.42	.4332	33 k		
	.43	.4333	33 k		
	.44	1.912.001.44	10 k	2 x 10k POS. LOG. POT	ST
	.45	57.11.4332	33 k		
	.46	.4333	33 k		
	.47	.4332	33 k		
	.148	.4104	100 k		
5	.49	.5106	10 M		
5	.50	.5106	10 M		
	.51	.4333	33 k		
	.52	.4332	33 k		
	.153	.4104	100 k		
5	.54	.5106	10 M		
5	.55	.5106	10 M		
1	.56	.4333	33 k	*	
1	.57	.4332	33 k	*	
1	.158	.4104	100 k	*	
5	.59	.5106	10 M	*	

IND	DATE	NAME		
①	11.12.84	⑤ 11.4.85	ST : STUDER	
③	4.10.84	④		
②	11.5.84	⑥		
①	9.2.84	⑦		
○	21.6.82	TAMAS		* only 8CH
STUDER HL ST INPUT UNIT 4CH/FILTER PL 1.912.240.00 PAGE 8 OF 13				

IND	POS NO	PART NO	VALUE	SPECIFICATIONS/EQUIVALENT	MFR
	XIC	53.03.0166	8p	IC - SOCKET	
		53.03.0167	14p	"	
		53.03.0168	16p	"	
1	W 1			OPTION 1 : replaced R172	
1	2			OPTION 1 : replaced R272	
1	3			1.912.241/243.00 : replaced R128	
1	4			1.912.241/243.00 : replaced R228	
1	5			only 4CH	
1	6			only PCB 1.912.240-11 INDEX O	*
1	7				*
1	8			only 4CH	
1	9				*
1	10			only 4CH	
1	11			only 1.912.241/243.00	
1	12			only 1.912.241/243.00	

IND	DATE	NAME	
④	11.12.84	⑤ 11.4.85 <i>fa</i>	
③	4.10.84	<i>fa</i>	OPTION 1 with Filter
②	11.5.84	<i>fa</i>	
①	9.2.84	<i>fa</i>	* only 8CH
○	22.6.82	TAMAS <i>fa</i>	
STUDER		HL ST INPUT UNIT 4CH/FILTER	PL 1.912.240.00 PAGE 13 OF 13

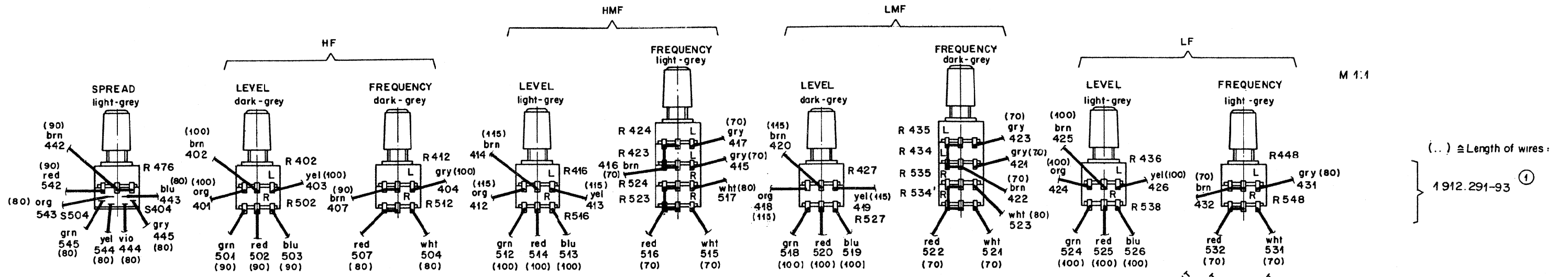

M 1:1

(...) ≙ Length of wires:
1.912.291-93 ①

1.912.291-94 ①

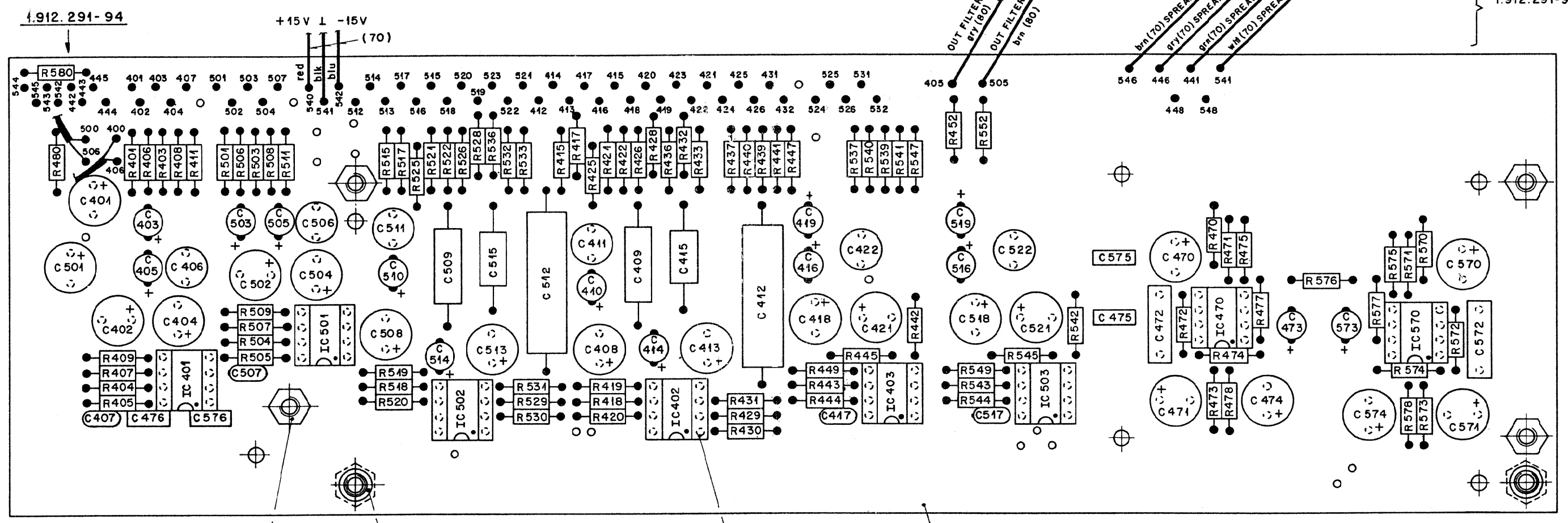

21.01.0354 (4x)
24.16.4030 (4x)
1.010.041-27 (4x)

1.010.040-22 (2x) ②

53.03.0166 (8x)

1.912.291-12

Werkstoff	Norm-Nr.:	Güte:	Anderung	③
	DIN-Bez.:			12.9.85 A.Ho <i>mls mls</i> ②
Zugehörige Unterlagen:	Abmessung:	Freimasstoleranz:	Maßstab:	22.5.84 STJ <i>Vr Vr</i> ①
	PL			8.9.83 A.Ho <i>Vr de</i> ①
Ersatz für:	Ersetzt durch:	Ausgabe Datum Gez. Gepr. Ges. Index		
STUDER REGENSDORF ZÜRICH		Benennung Equalizer Board		Nummer: 1.912.291-00

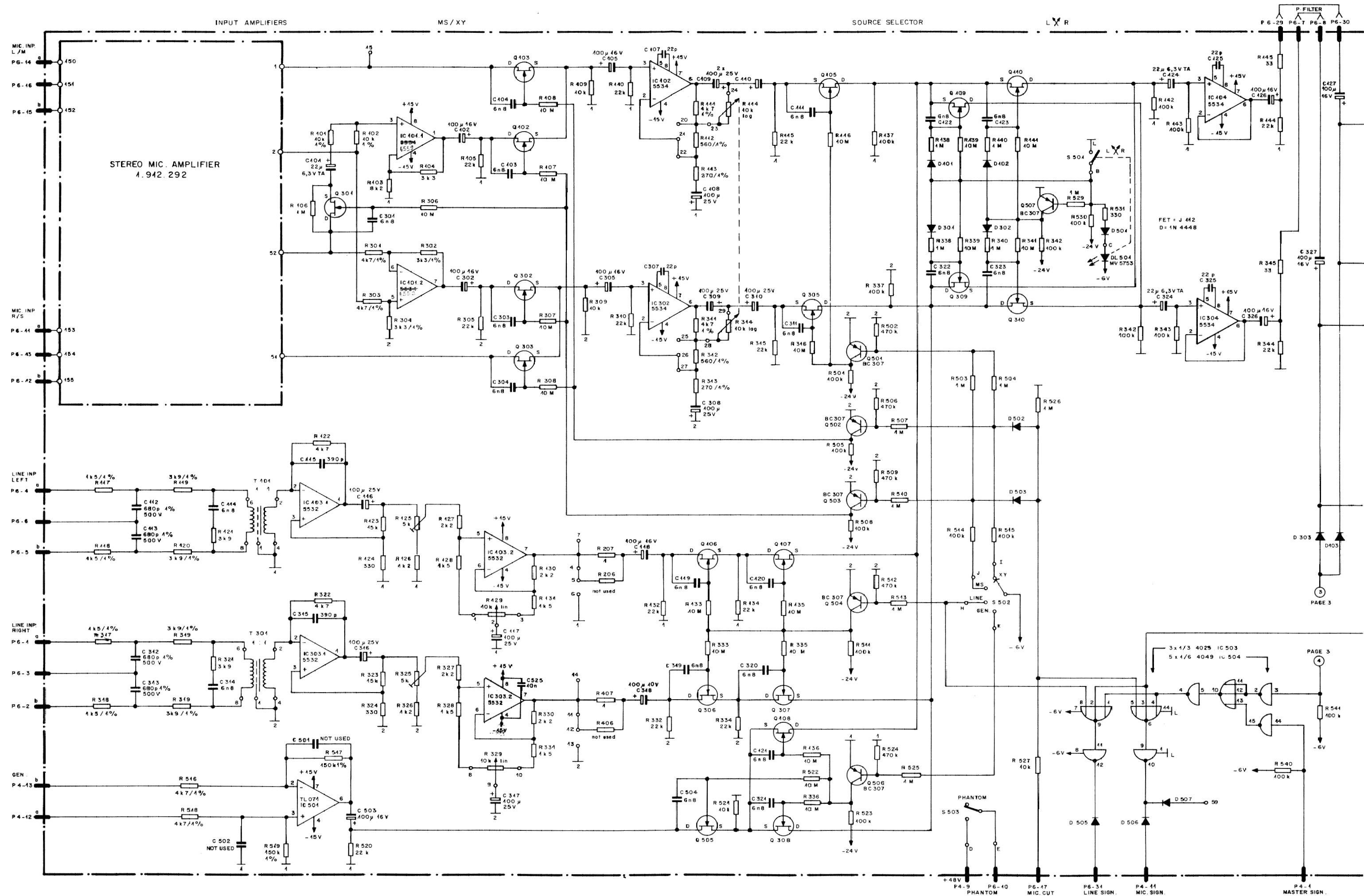

STEREO MIC. AMPLIFIER
1.942.292

FET: J 442
D: 1N 4448

HIGH PASS (30 Hz - 330 Hz)

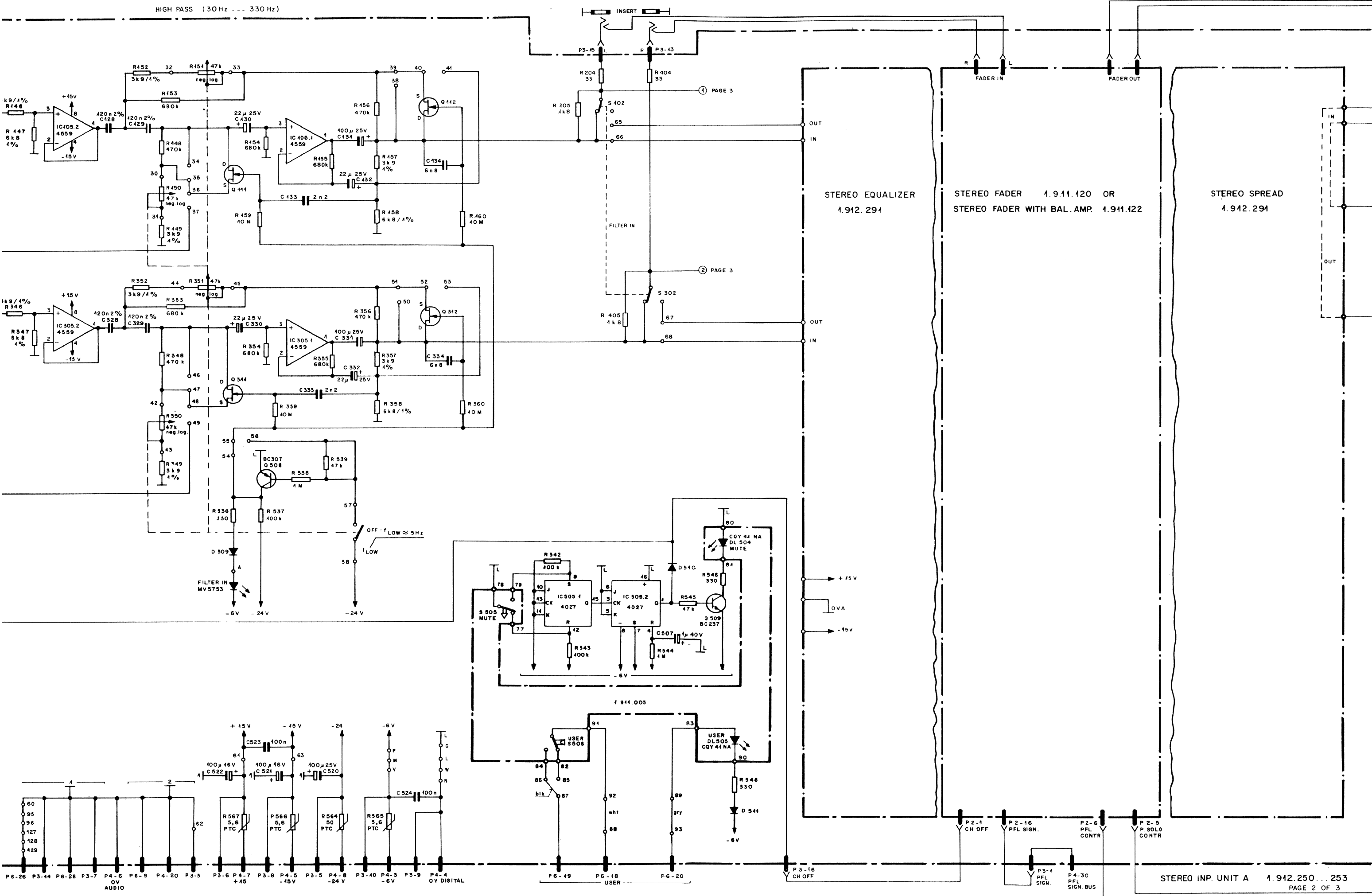

STEREO EQUALIZER
1.912.291

STEREO FADER 1.911.120 OR
STEREO FADER WITH BAL. AMP. 1.911.122

STEREO SPREAD
1.912.291

STEREO INP. UNIT A 1.912.250...253
PAGE 2 OF 3

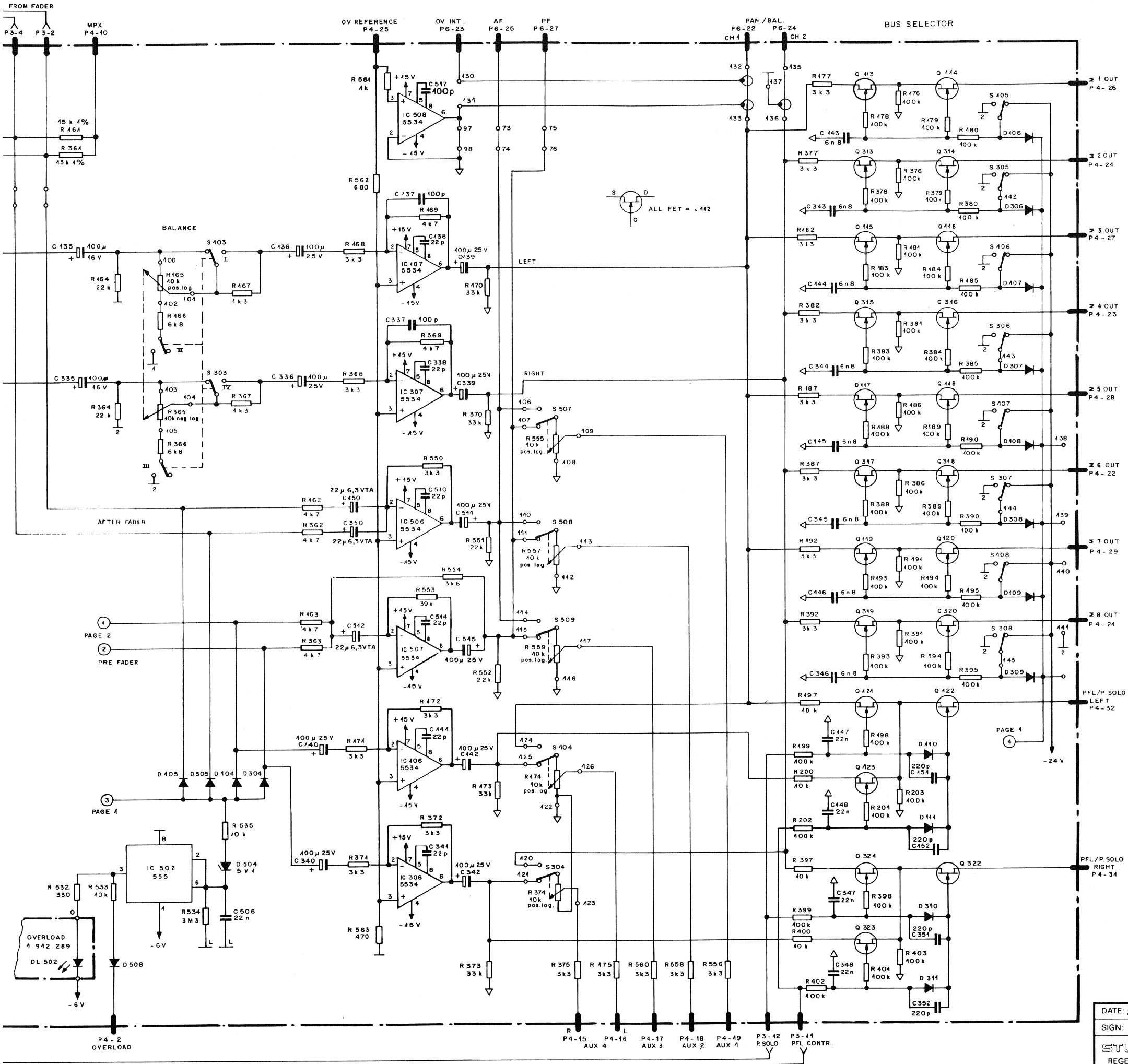

- P 6
- 1 LINE a
 - 2 LINE b
 - 3 SCREEN
 - 4 LINE a
 - 5 LINE b
 - 6 SCREEN
 - 7 P-FILTER OUT
 - 8 P-FILTER IN
 - 9 OVA
 - 10 X
 - 11 MIC. a
 - 12 MIC. b
 - 13 SCREEN
 - 14 MIC. a
 - 15 MIC. b
 - 16 SCREEN
 - 17 X
 - 18 USER
 - 19 USER
 - 20 USER
 - 21 X
 - 22 CH 1 PAN/BAL
 - 23 OV INT.
 - 24 CH 2 PAN/BAL
 - 25 AF OUT
 - 26 OVA
 - 27 PF-OUT
 - 28 OVA
 - 29 P-FILTER OUT
 - 30 P-FILTER IN
 - 31 LINE SIGN.
 - 32 X
- P 4
- 1 MASTER SIGN.
 - 2 OVERLOAD
 - 3 -6V
 - 4 OVL
 - 5 -15V
 - 6 OVA
 - 7 +15V
 - 8 -24V
 - 9 -15V
 - 10 OVL
 - 11 -6V
 - 12 MPX
 - 13 MIC. SIGN
 - 14 GEN. a
 - 15 GEN. b
 - 16 X
 - 17 AUX 4-R OUT
 - 18 AUX 4-L OUT
 - 19 AUX 3 OUT
 - 20 AUX 2 OUT
 - 21 AUX 1 OUT
 - 22 OVA
 - 23 8 OUT
 - 24 6 OUT
 - 25 4 OUT
 - 26 2 OUT
 - 27 1 OUT
 - 28 3 OUT
 - 29 5 OUT
 - 30 7 OUT
 - 31 PFL - SIGN. BUS
 - 32 PFL/P-SOLO R
 - 33 PFL/P-SOLO L
- P 3
- 1 PFL-SIGN. BUS
 - 2 FADER OUT L
 - 3 OVA R
 - 4 FADER OUT R
 - 5 -24V
 - 6 +15V
 - 7 OVA
 - 8 -15V
 - 9 OVL
 - 10 -6V
 - 11 PFL CONTR.
 - 12 P-SOLO CONTR
 - 13 FADER IN R
 - 14 OVA L
 - 15 FADER IN L
 - 16 CH-OFF
- P 2
- 1 CH-OFF
 - 2 FADER IN L
 - 3 OVA L
 - 4 FADER IN R
 - 5 P-SOLO CONTR.
 - 6 PFL CONTR.
 - 7 -6V
 - 8 OVL
 - 9 -15V
 - 10 OVA
 - 11 -24V
 - 12 +15V
 - 13 FADER OUT R
 - 14 OVA R
 - 15 FADER OUT L
 - 16 PFL-SIGN. BUS

ALL FET ARE J 112
ALL DIODES ARE 1N 4448

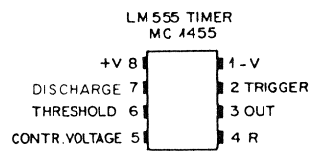
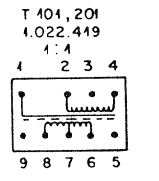
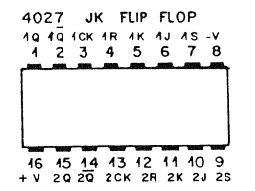
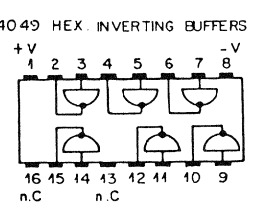
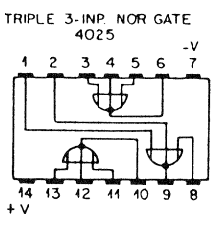
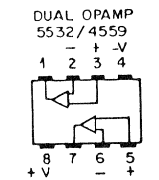
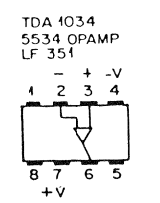

BOTTOM VIEW

DATE: 27. 2. 84	1. 3. 84	25. 5. 84	4. 10. 84		PAGE 3 OF 3
SIGN: <i>We</i>	<i>We</i>	<i>We</i>	<i>Wl</i>		
STUDER REGENSDORF ZURICH	STEREO INPUT UNIT A			SC 1.912.250... 253	

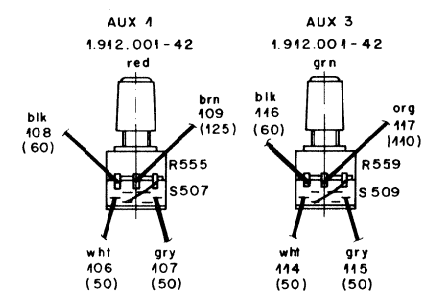
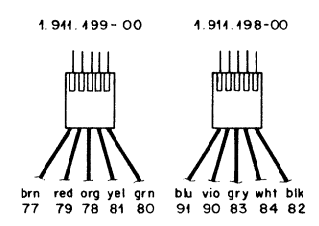
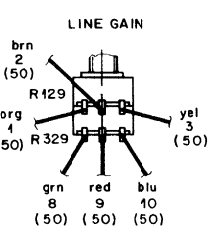
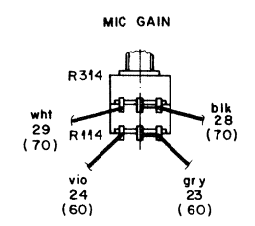
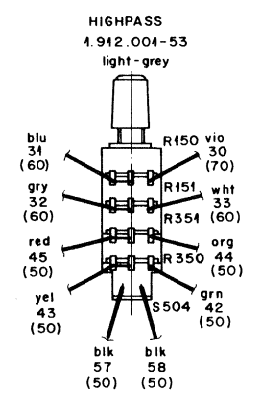
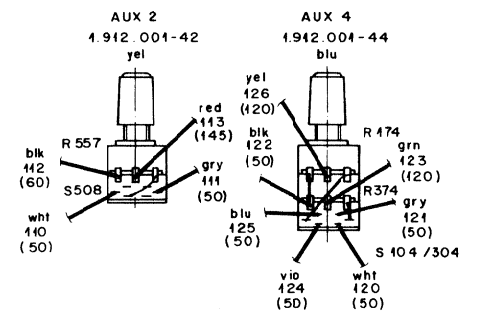
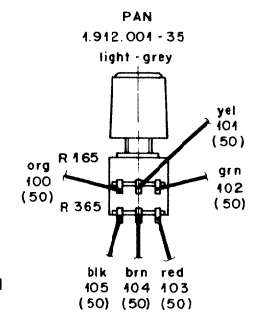

(...) Δ LENGTH OF STRANDS 1.912.250-93

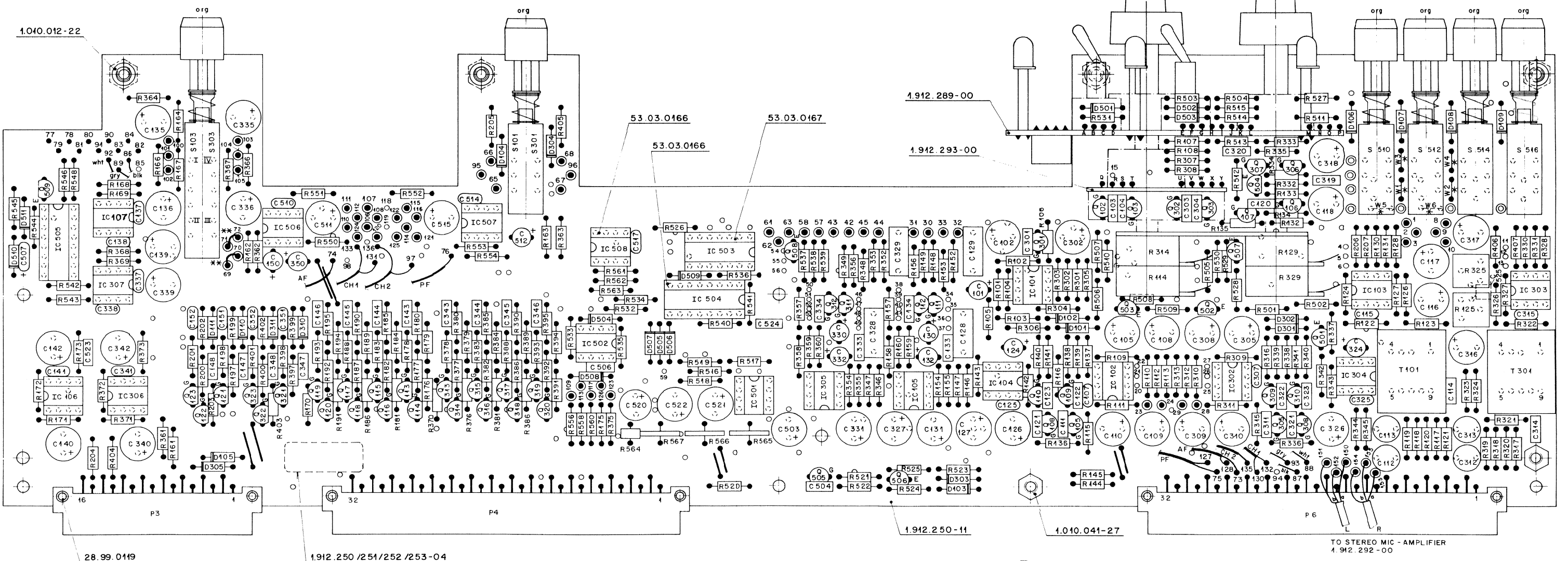

* 4 CH : 1.912.250/251-00
ONLY W3, W4, W5, W6
ARE REQUIRED

* 8 CH : 1.912.252/253-00
ONLY W1 AND W2
ARE REQUIRED

** ONLY 1.912.251-00
AND 1.912.253-00

WIRINGDIAGRAM	
STEREO-INPUT	EQUALIZER
1.912.250/252-00	1.912.291-00
61	540
62	541
63	542
68	506
96	500
67	505
66	406
95	400
65	405
99	444
71	446
70	541
72	546

VALID FOR	NR. UNIT	NR. PL	EQUALIZER
4 CH FILTER	1.912.250-00	1.912.250-00	1.912.291-00
4 CH	1.912.251-00	1.912.250-00	-
8 CH FILTER	1.912.252-00	1.912.250-00	1.912.291-00
8 CH	1.912.253-00	1.912.250-00	-

Norm-Nr.	Güte	Ausgabe
Werkstoff	Beh.	
DIN-Bez.	Oberfläche	Anforderung
Abmessung	Beh.	
Zugehörige Unterlagen	Freimassstokanz.	Maßstab
LL, KL		
Ersatz für	Ersetzt durch	Kopie für
STUDEF REGENSDORF ZÜRICH		Stereo Input Unit 4 CH / 8 CH
4.4. 85 Si 27.2. 84A.Ho		26.10.83A.Ho
Datum		Gez. Gepr. Ges. Index
Nummer		1.912.250-00

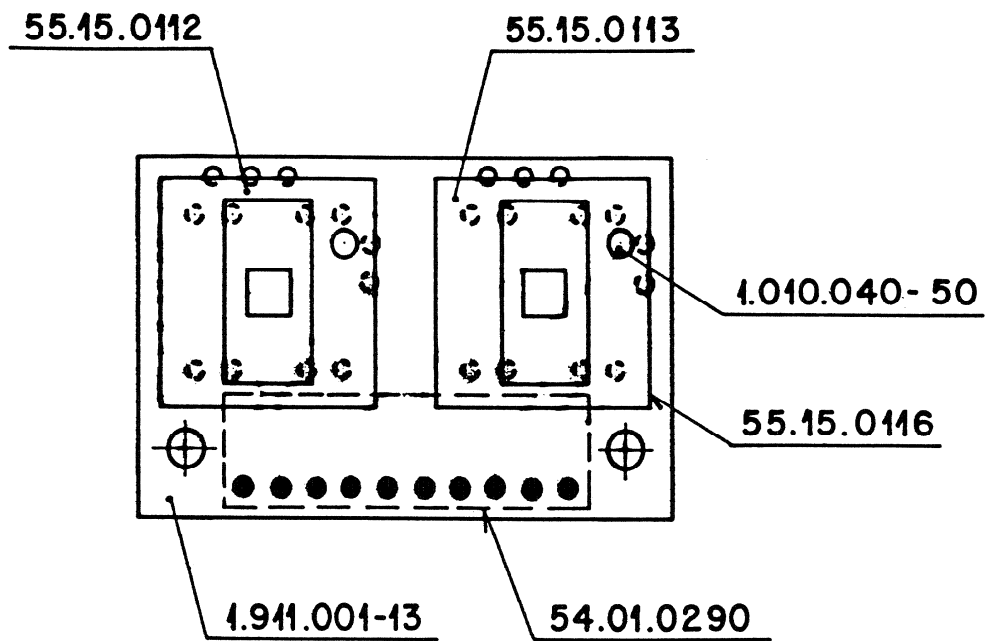

Werkstoff	Norm-Nr.:	Oberfläche	Güte:					③
	DIN-Bez.:		Beh.:					②
	Abmessung:						①	
Zugehörige Unterlagen:		Freimasstoleranz:	Maßstab:	19.5.82	Ho	W		⑤
		±	2 : 1	Datum	Gez.	Gepr.	Ges.	Index
Ersatz für:		Ersetzt durch:		Kopie für:				
STUDER REGENSDORF ZÜRICH		Bezeichnung: Pushbutton Board N-L		Nummer: 1.911.003-00				

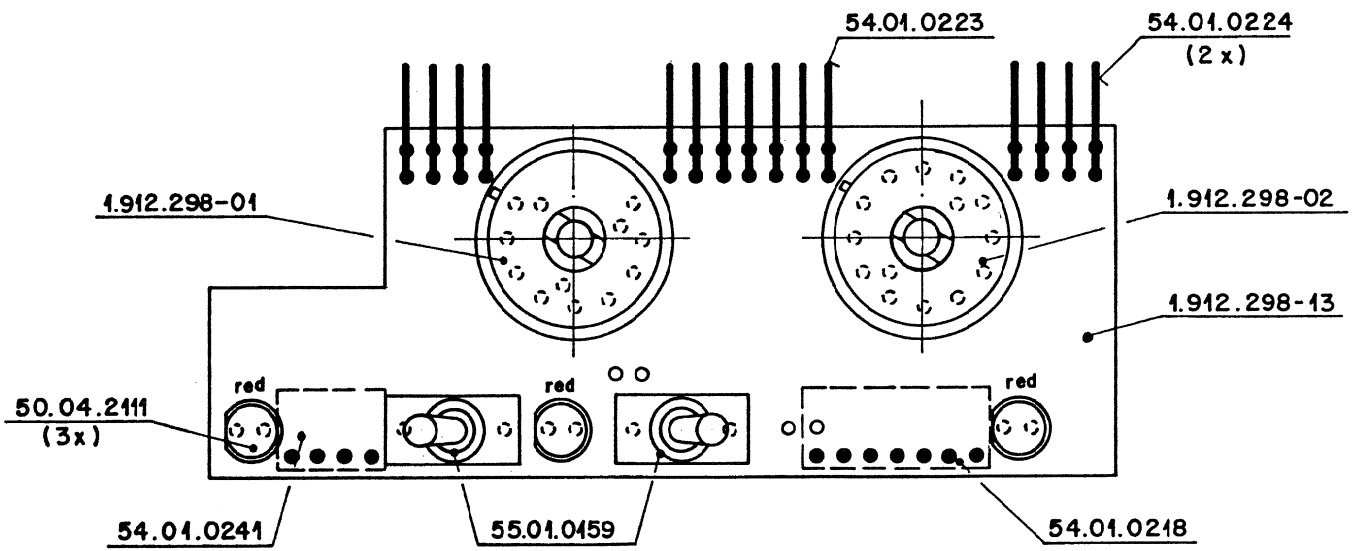
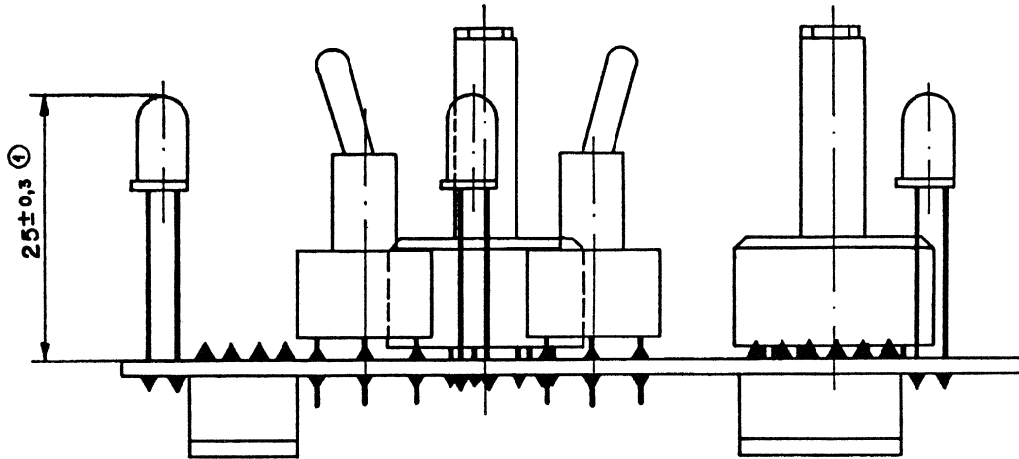

Werkstoff	Norm-Nr.:	ESZn:	Anzahl		①
DN-Bez.:	LOKATION	ESL:			②
Abmessung:					③
Zugehörige Linienlagen:	Polzahl/Leitung:	Material:	25.11.83 A.Ho	H	④
	+	2 x 1	Datum	Gez.	Gepr.
Erstellt für:	Erstellt durch:	Gepr. für:			
STUDER REGENSDORF ZÜRICH		Switch-Board Stereo		1.912.289-00	

Schalter während dem Lötén
auf Print pressen.

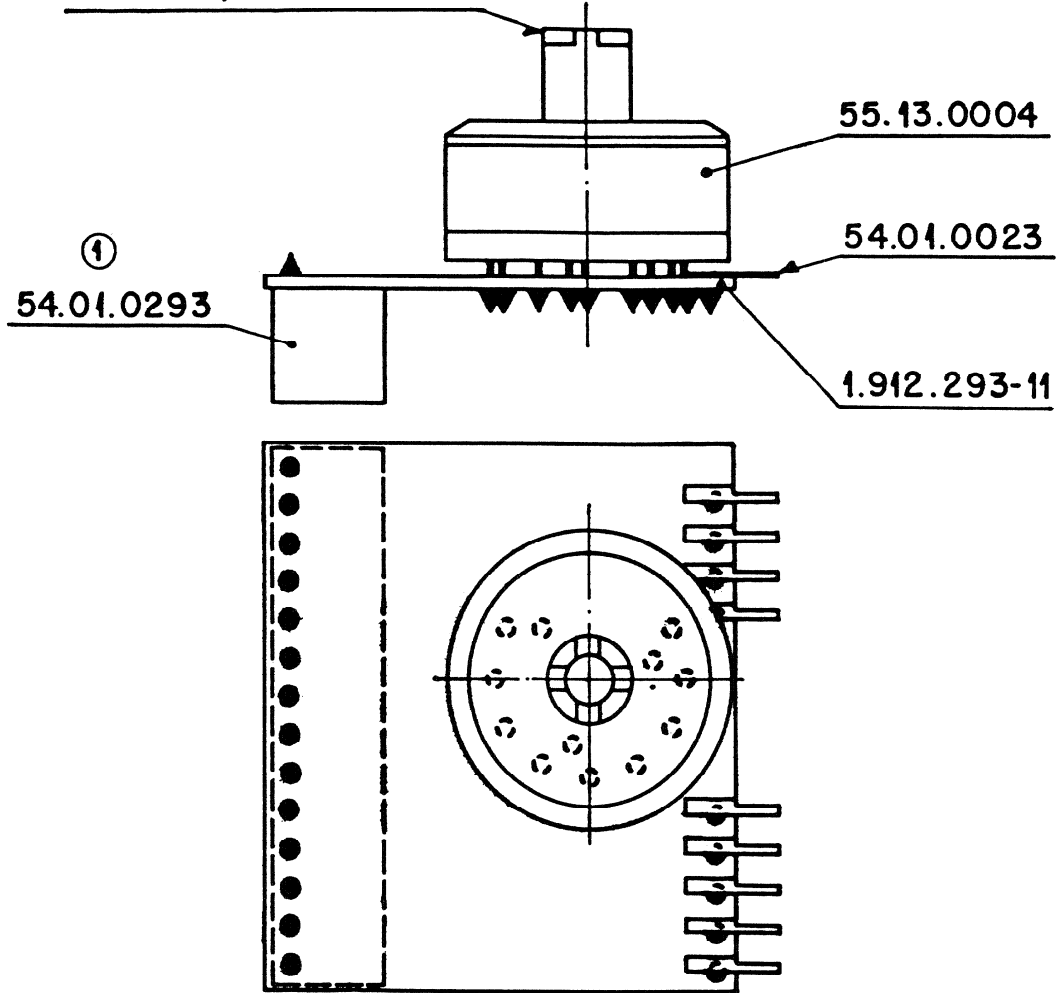

Werkstoff	Norm-Nr.:	Oberfläche	Güte:	Änderung					③	
	DIN-Bez.:		Beh.:							②
	Abmessung:				13.1.84	A.Ho	V	V		①
Zugehörige Unterlagen:	Freimasstoleranz:	Maßstab:	Ausgabe	6.5.83	A.Ho	V	de		①	
			Datum	Gez.	Gepr.	Ges.	Index			
Ersatz für:	Ersetzt durch:		Kopie für:							
STUDER REGENSDORF ZÜRICH		Bezeichnung: Switch Interface		Nummer: 1.912.293-00						

IND.	POS.NO.	PART NO.	VALUE	SPECIFICATIONS / EQUIVALENT			MANUF.
	A.....1	1.912.292.00		STEREO-MIC-AMPLIFIER			
	A.....2	1.912.293.00		SWITCH-INTERFACE			
	A.....3	1.912.289.00		SWITCH-BOARD-STEREO			
	A.....4	1.911.003.00		PUSHBUTTON BOARD N-L			
	A.....5	1.911.199.00		CONNECTING CABLE 1			
	A.....6	1.911.198.00		CONNECTING CABLE 2			
	A.....7			EQUALIZER-BOARD	1.912.291.00	option 2	
	C...101	59.30.2220	22 uF	-20%	6.3V	TA	
	C...102	59.22.4101	100 uF	-10%	16V	EL	
	C...103	59.06.0682	6.8 nF	10%	50V	PE	
	C...104	59.06.0682	6.8 nF	10%	50V	PE	
	C...105	59.22.4101	100 uF	-20%	16V	EL	
	C...106		not used				
	C...107	59.34.2220	22 pF	5%		CE	
	C...108	59.22.4101	100 uF	-20%	16V	EL	
	C...109	59.22.4101	100 uF	-20%	16V	EL	
	C...110	59.22.4101	100 uF	-20%	16V	EL	
	C...111	59.06.0682	6.8 nF	10%	50V	EL	
	C...112	59.05.1681	680 pF	1%	500V	PP	
	C...113	59.05.1681	680 pF	1%	500V	PP	
(01)	C...114	59.06.0682	6.8 nF	10%	50V	PE	
(01)	C...115	59.34.5391	390 pF	5%		CE	
	C...116	59.22.4101	100 uF	-20%	16V	EL	
	C...117	59.22.4101	100 uF	-20%	16V	EL	
	C...118	59.22.4101	100 uF	-20%	16V	EL	
	C...119	59.06.0682	6.8 nF	10%	50V	PE	
	C...120	59.06.0682	6.8 nF	10%	50V	PE	
	C...121	59.06.0682	6.8 nF	10%	50V	PE	
	C...122	59.06.0682	6.8 nF	10%	50V	PE	
	C...123	59.06.0682	6.8 nF	10%	50V	PE	
	C...124	59.30.2220	22 uF	-20%	6.3V	TA	
	C...125	59.34.2220	22 pF	5%		CE	
	C...126	59.22.4101	100 uF	-20%	16V	EL	
	C...127	59.22.4101	100 uF	-20%	16V	EL	
(01)	C...128	59.02.2124	120 nF	5%		PC	
(01)	C...129	59.02.2124	120 nF	5%		PC	
S T U D E R (04) 84/10/04 TA			STEREO-INPUT-4CH/8CH	1.912.250.00	PAGE	1	

IND.	POS.NO.	PART NO.	VALUE	SPECIFICATIONS / EQUIVALENT			MANUF.
	C...130	59.30.2220	22 uF	-20%	6.3V	TA	
	C...131	59.22.4101	100 uF	-20%	16V	EL	
	C...132	59.30.2220	22 uF	-20%	6.3V	TA	
	C...133	59.06.0222	2.2 nF	10%	50V	PE	
	C...134	59.06.0682	6.8 nF	10%	50V	PE	
	C...135	59.22.4101	100 uF	-20%	16V	EL	
	C...136	59.22.4101	100 uF	-20%	16V	EL	
	C...137	59.34.4101	100 pF	5%		CE	
	C...138	59.34.2220	22 pF	5%		CE	
	C...139	59.22.4101	100 uF	-20%	16V	EL	
	C...140	59.22.4101	100 uF	-20%	16V	EL	
	C...141	59.34.2220	22 pF	5%		CE	
	C...142	59.22.4101	100 uF	-20%	16V	EL	
	C...143	59.06.0682	6.8 nF	10%	50V	PE	
	C...144	59.06.0682	6.8 nF	10%	50V	PE	
	C...145	59.06.0682	* 6.8 nF	10%	50V	PE	
	C...146	59.06.0682	* 6.8 nF	10%	50V	PE	
	C...147	59.06.0223	22 nF	10%	50V	PE	
	C...148	59.06.0223	22 nF	10%	50V	PE	
	C...149		not used				
	C...150	59.30.2220	22 uF	-20%	6.3V	TA	
	C...151	59.34.4221	220 pF	5%		CE	
	C...152	59.34.4221	220 pF	5%		CE	
	C...301	59.06.0682	6.8 nF	10%	50V	PE	
	C...302	59.22.4101	100 uF	-10%	16V	EL	
	C...303	59.06.0682	6.8 nF	10%	50V	PE	
	C...304	59.06.0682	6.8 nF	10%	50V	PE	
	C...305	59.22.4101	100 uF	-20%	16V	EL	
	C...306		not used				
	C...307	59.34.2220	22 pF	5%		CE	
	C...308	59.22.4101	100 uF	-20%	16V	EL	
	C...309	59.22.4101	100 uF	-20%	16V	EL	
	C...310	59.22.4101	100 uF	-20%	16V	EL	
	C...311	59.06.0682	6.8 nF	10%	50V	EL	
	C...312	59.05.1681	680 pF	1%	500V	PP	
	C...313	59.05.1681	680 pF	1%	500V	PP	
(01)	C...314	59.06.0682	6.8 nF	10%	50V	PE	
S T U D E R (04) 84/10/04 TA			STEREO-INPUT-4CH/8CH	1.912.250.00	PAGE	2	

IND.	POS.NO.	PART NO.	VALUE	SPECIFICATIONS / EQUIVALENT			MANUF.
(01)	C...315	59.34.5391	390 pF	5%		CE	
	C...316	59.22.4101	100 uF	-20%	16V	EL	
	C...317	59.22.4101	100 uF	-20%	16V	EL	
(03)	C...318	59.22.3101	100 uF	-20%	10V	EL	
	C...319	59.06.0682	6.8 nF	10%	50V	PE	
	C...320	59.06.0682	6.8 nF	10%	50V	PE	
	C...321	59.06.0682	6.8 nF	10%	50V	PE	
	C...322	59.06.0682	6.8 nF	10%	50V	PE	
	C...323	59.06.0682	6.8 nF	10%	50V	PE	
	C...324	59.30.2220	22 uF	-20%	6.3V	TA	
	C...325	59.34.2220	22 pF	5%		CE	
	C...326	59.22.4101	100 uF	-20%	16V	EL	
	C...327	59.22.4101	100 uF	-20%	16V	EL	
(01)	C...328	59.02.2124	120 nF	5%		PC	
(01)	C...329	59.02.2124	120 nF	5%		PC	
	C...330	59.30.2220	22 uF	-20%	6.3V	TA	
	C...331	59.22.4101	100 uF	-20%	16V	EL	
	C...332	59.30.2220	22 uF	-20%	6.3V	TA	
	C...333	59.06.0222	2.2 nF	10%	50V	PE	
	C...334	59.06.0682	6.8 nF	10%	50V	PE	
	C...335	59.22.4101	100 uF	-20%	16V	EL	
	C...336	59.22.4101	100 uF	-20%	16V	EL	
	C...337	59.34.4101	100 pF	5%		CE	
	C...338	59.34.2220	22 pF	5%		CE	
	C...339	59.22.4101	100 uF	-20%	16V	EL	
	C...340	59.22.4101	100 uF	-20%	16V	EL	
	C...341	59.34.2220	22 pF	5%		CE	
	C...342	59.22.4101	100 uF	-20%	16V	EL	
	C...343	59.06.0682	6.8 nF	10%	50V	PE	
	C...344	59.06.0682	6.8 nF	10%	50V	PE	
	C...345	59.06.0682	* 6.8 nF	10%	50V	PE	
	C...346	59.06.0682	* 6.8 nF	10%	50V	PE	
	C...347	59.06.0223	22 nF	10%	50V	PE	
	C...348	59.06.0223	22 nF	10%	50V	PE	
	C...349		not used				
	C...350	59.30.2220	22 uF	-20%	6.3V	TA	
	C...351	59.34.4221	220 pF	5%		CE	

S T U D E R (04) 84/10/04 TA STEREO-INPUT-4CH/8CH 1.912.250.00 PAGE 3

IND.	POS.NO.	PART NO.	VALUE	SPECIFICATIONS / EQUIVALENT			MANUF.
	C...352	59.34.4221	220 pF	5%		CE	
	C...501		not used				
	C...502		not used				
	C...503	59.22.4101	100 uF	-20%	16V	EL	
	C...504	59.06.0682	6.8 nF	10%	50V	PE	
	C...505		not used				
(03)	C...506	59.06.0223	22 nF	10%	50V	PE	
	C...507	59.26.9109	1 uF		25V	SAL	
	C...508		not used				
	C...509		not used				
	C...510	59.34.2220	22 pF	5%		CE	
	C...511	59.22.4101	100 uF	-10%	16V	EL	
	C...512	59.30.2220	22 uF	-20%	6.3V	TA	
	C...513		not used				
	C...514	59.34.2220	22 pF	5%		CE	
	C...515	59.22.4101	100 uF	-10%	16V	EL	
(04)	C...516		not used				
	C...517	59.34.4101	100 pF	5%		CE	
	C...518		not used				
	C...519		not used				
	C...520	59.22.5101	100 uF	-10%	25V	EL	
	C...521	59.22.4101	100 uF	-10%	16V	EL	
	C...522	59.22.4101	100 uF	-10%	16V	EL	
	C...523	59.06.0104	100 nF		50V	PE	
	C...524	59.06.0104	100 nF		50V	PE	
(01)	C...525	59.32.3103	10 nF			CE	
	D...101	50.04.0125	1N4448				any
	D...102	50.04.0125	1N4448				any
	D...103	50.04.0125	1N4448				any
	D...104	50.04.0125	1N4448				any
	D...105	50.04.0125	1N4448				any
(03)	D...106	50.04.0125	* 1N4448				any
	D...107	50.04.0125	1N4448				any
(03)	D...108	50.04.0125	1N4448				any
	D...109	50.04.0125	* 1N4448				any
	D...110	50.04.0125	1N4448				any

S T U D E R (04) 84/10/04 TA STEREO-INPUT-4CH/8CH 1.912.250.00 PAGE 4

IND.	POS.NO.	PART NO.	VALUE	SPECIFICATIONS / EQUIVALENT	MANUF.
	D...111	50.04.0125	1N4448		any
	D...301	50.04.0125	1N4448		any
	D...302	50.04.0125	1N4448		any
	D...303	50.04.0125	1N4448		any
	D...304	50.04.0125	1N4448		any
	D...305	50.04.0125	1N4448		any
	D...306		1N4448	50040125	any
	D...307		1N4448	50040125	any
	D...308		* 1N4448	50040125	any
	D...309		* 1N4448	50040125	any
	D...310	50.04.0125	1N4448		any
	D...311	50.04.0125	1N4448		any
	D...501	50.04.0125	1N4448		any
	D...502	50.04.0125	1N4448		any
	D...503	50.04.0125	1N4448		any
	D...504	50.04.1112	Z 5.1V	400mW BZX83C 5.1, BZX55C 5.1, ZPD 5.1	any
	D...505	50.04.0125	1N4448		any
	D...506	50.04.0125	1N4448		any
	D...507	50.04.0125	1N4448		any
	D...508	50.04.0125	1N4448		any
	D...509	50.04.0125	1N4448		any
	D...510	50.04.0125	1N4448		any
	D...511	50.04.0125	1N4448		any

	IC..101	50.09.0107	RC4559 N	dual op. amp.	Ti,Sig,Ra
	IC..102	50.05.0244	NE5534AN	single op. amp. low noise	Ti,Sig,Ra
	IC..103	50.09.0106	NE5532AN	dual op. amp. low noise	Ti,Sig,Ra
	IC..104	50.05.0243	NE5534 N	single op. amp.	Ti,Sig,Ra
(02)	IC..105	50.09.0107	RC4559 N	dual op. amp.	Ti,Sig,Ra
	IC..106	50.05.0243	NE5534 N	single op. amp.	Ti,Sig,Ra
	IC..107	50.05.0243	NE5534 N	single op. amp.	Ti,Sig,Ra
	IC..302	50.05.0244	NE5534AN	single op. amp. low noise	Ti,Sig,Ra
	IC..303	50.09.0106	NE5532AN	dual op. amp. low noise	Ti,Sig,Ra
	IC..304	50.05.0243	NE5534 N	single op. amp.	Ti,Sig,Ra
(02)	IC..305	50.09.0107	RC4559 N	dual op. amp.	Ti,Sig,Ra
	IC..306	50.05.0243	NE5534 N	single op. amp.	Ti,Sig,Ra
	IC..307	50.05.0243	NE5534 N	single op. amp.	Ti,Sig,Ra

S T U D E R (04) 84/10/04 TA STEREO-INPUT-4CH/8CH 1.912.250.00 PAGE 5

IND.	POS.NO.	PART NO.	VALUE	SPECIFICATIONS / EQUIVALENT	MANUF.
	IC..501	50.09.0103	TL 071	single op. amp.	TI
	IC..502	50.05.0158	NE 555	timer	Siq,Mot,NSC
	IC..503	50.07.0012	CD4025	3-input nor-gate CMOS	Mot,Fc,NSC
	IC..504	50.07.0049	CD4049	hex. inverter CMOS	Fc,Mot
	IC..505	50.07.0027	CD4027	dual JK-FF CMOS	Mot,Fc
	IC..506	50.05.0243	NE5534N	single op. amp.	TI,Sig,Ra
	IC..507	50.05.0243	NE5534N	single op. amp.	TI,Sig,Ra
	IC..508	50.05.0243	NE5534N	single op. amp.	TI,Sig,Ra
	P.....3	54.11.2007	2*8 pin	euroconnector	Bu
	P.....4	54.01.0359	2*16pin	euroconnector	Bu
	P.....6	54.01.0359	2*16pin	euroconnector	Bu
	Q...102	50.03.0350	J 112	N-JFET	NS,Mot,Six
	Q...103	50.03.0350	J 112	N-JFET	NS,Mot,Six
	Q...105	50.03.0350	J 112	N-JFET	NS,Mot,Six
	Q...106	50.03.0350	J 112	N-JFET	NS,Mot,Six
	Q...107	50.03.0350	J 112	N-JFET	NS,Mot,Six
	Q...108	50.03.0350	J 112	N-JFET	NS,Mot,Six
	Q...109	50.03.0350	J 112	N-JFET	NS,Mot,Six
	Q...110	50.03.0350	J 112	N-JFET	NS,Mot,Six
	Q...111	50.03.0350	J 112	N-JFET	NS,Mot,Six
	Q...112	50.03.0350	J 112	N-JFET	NS,Mot,Six
	Q...113	50.03.0350	J 112	N-JFET	NS,Mot,Six
	Q...114	50.03.0350	J 112	N-JFET	NS,Mot,Six
	Q...115	50.03.0350	J 112	N-JFET	NS,Mot,Six
	Q...116	50.03.0350	J 112	N-JFET	NS,Mot,Six
	Q...117	50.03.0350	* J 112	N-JFET	NS,Mot,Six
	Q...118	50.03.0350	* J 112	N-JFET	NS,Mot,Six
	Q...119	50.03.0350	* J 112	N-JFET	NS,Mot,Six
	Q...120	50.03.0350	* J 112	N-JFET	NS,Mot,Six
	Q...121	50.03.0350	J 112	N-JFET	NS,Mot,Six
	Q...122	50.03.0350	J 112	N-JFET	NS,Mot,Six
	Q...123	50.03.0350	J 112	N-JFET	NS,Mot,Six
	Q...301	50.03.0350	J 112	N-JFET	NS,Mot,Six
	Q...302	50.03.0350	J 112	N-JFET	NS,Mot,Six
	Q...303	50.03.0350	J 112	N-JFET	NS,Mot,Six

S T U D E R (04) 84/10/04 TA STEREO-INPUT-4CH/8CH 1.912.250.00 PAGE 6

IND.	POS.NO.	PART NO.	VALUE	SPECIFICATIONS / EQUIVALENT	MANUF.
	Q...305	50.03.0350	J 112	N-JFET	NS,Mot,Six
	Q...306	50.03.0350	J 112	N-JFET	NS,Mot,Six
	Q...307	50.03.0350	J 112	N-JFET	NS,Mot,Six
	Q...308	50.03.0350	J 112	N-JFET	NS,Mot,Six
	Q...309	50.03.0350	J 112	N-JFET	NS,Mot,Six
	Q...310	50.03.0350	J 112	N-JFET	NS,Mot,Six
	Q...311	50.03.0350	J 112	N-JFET	NS,Mot,Six
	Q...312	50.03.0350	J 112	N-JFET	NS,Mot,Six
	Q...313	50.03.0350	J 112	N-JFET	NS,Mot,Six
	Q...314	50.03.0350	J 112	N-JFET	NS,Mot,Six
	Q...315	50.03.0350	J 112	N-JFET	NS,Mot,Six
	Q...316	50.03.0350	J 112	N-JFET	NS,Mot,Six
	Q...317	50.03.0350	* J 112	N-JFET	NS,Mot,Six
	Q...318	50.03.0350	* J 112	N-JFET	NS,Mot,Six
	Q...319	50.03.0350	* J 112	N-JFET	NS,Mot,Six
	Q...320	50.03.0350	* J 112	N-JFET	NS,Mot,Six
	Q...321	50.03.0350	J 112	N-JFET	NS,Mot,Six
	Q...322	50.03.0350	J 112	N-JFET	NS,Mot,Six
	Q...323	50.03.0350	J 112	N-JFET	NS,Mot,Six
	Q...501	50.03.0515	BC 307	PNP IC>100mA, B>100	any
	Q...502	50.03.0515	BC 307	PNP IC>100mA, B>100	any
	Q...503	50.03.0515	BC 307	PNP IC>100mA, B>100	any
	Q...504	50.03.0515	BC 307	PNP IC>100mA, B>100	any
	Q...505	50.03.0350	J 112	N-JFET	NS,Mot,Six
	Q...506	50.03.0515	BC 307	PNP IC>100mA, B>100	any
	Q...507	50.03.0515	BC 307	PNP IC>100mA, B>100	any
	Q...508	50.03.0515	BC 307	PNP IC>100mA, B>100	any
	Q...509	50.03.0436	BC 237	NPN IC>100mA, B>100	any
	R...101	57.11.3103	10 kOhm	1% 0.25W MF	
	R...102	57.11.3103	10 kOhm	1% 0.25W MF	
	R...103	57.11.4822	8.2 kOhm	5% 0.25W MF	
	R...104	57.11.4332	3.3 kOhm	5% 0.25W MF	
	R...105	57.11.4223	22 kOhm	5% 0.25W MF	
	R...106	57.11.4105	1 MOhm	5% 0.25W MF	
	R...107	57.11.6106	10 MOhm	10% 0.25W MF	
	R...108	57.11.6106	10 MOhm	10% 0.25W MF	

S T U D E R (04) 84/10/04 TA STEREO-INPUT-4CH/8CH 1.912.250.00 PAGE 7

IND.	POS.NO.	PART NO.	VALUE	SPECIFICATIONS / EQUIVALENT	MANUF.
	R...109	57.11.4103	10 kOhm	5% 0.25W MF	
	R...110	57.11.4223	22 kOhm	5% 0.25W MF	
	R...111	57.11.3472	4.7 kOhm	1% 0.25W MF	
	R...112	57.11.4561	560 Ohm	2% 0.25W MF	
	R...113	57.11.3271	270 Ohm	1% 0.25W MF	
	R...114	1.912.001.30	10 kOhm	5% pos.log.variable resistor	St
	R...115	57.11.4223	22 kOhm	5% 0.25W MF	
	R...116	57.11.6106	10 MOhm	10% 0.25W MF	
	R...117	57.11.3152	1.5 kOhm	1% 0.25W MF	
	R...118	57.11.3152	1.5 kOhm	1% 0.25W MF	
	R...119	57.11.3392	3.9 kOhm	1% 0.25W MF	
	R...120	57.11.3392	3.9 kOhm	1% 0.25W MF	
(01)	R...121	57.11.4392	3.9 kOhm	5% 0.25W MF	
(01)	R...122	57.11.4472	4.7 kOhm	5% 0.25W MF	
(01)	R...123	57.11.4153	15 kOhm	5% 0.25W MF	
(01)	R...124	57.11.4331	330 Ohm	5% 0.25W MF	
(01)	R...125	58.01.8502	5 kOhm	10% 0.50W trimming resistor	
(01)	R...126	57.11.4122	1.2 kOhm	5% 0.25W MF	
(01)	R...127	57.11.4222	2.2 kOhm	5% 0.25W MF	
	R...128	57.11.4152	1.5 kOhm	5% 0.25W MF	
	R...129	1.912.001.29	10 kOhm	10% lin. variable resistor	St
	R...130	57.11.4222	2.2 kOhm	5% 0.25W MF	
	R...131	57.11.4152	1.5 kOhm	5% 0.25W MF	
	R...132	57.11.4223	22 kOhm	5% 0.25W MF	
	R...133	57.11.6106	10 MOhm	10% 0.25W MF	
(01)	R...134	57.11.4223	22 kOhm	5% 0.25W MF	
	R...135	57.11.6106	10 MOhm	10% 0.25W MF	
(03)	R...136	57.11.6106	10 MOhm	10% 0.25W MF	
(01)	R...137	57.11.4104	100 kOhm	5% 0.25W MF	
	R...138	57.11.4105	1 MOhm	5% 0.25W MF	
	R...139	57.11.6106	10 MOhm	10% 0.25W MF	
	R...140	57.11.4105	1 MOhm	5% 0.25W MF	
	R...141	57.11.6106	10 MOhm	10% 0.25W MF	
(01)	R...142	57.11.4104	100 kOhm	5% 0.25W MF	
(01)	R...143	57.11.4104	100 kOhm	5% 0.25W MF	
	R...144	57.11.4223	22 kOhm	5% 0.25W MF	
	R...145	57.11.4330	33 Ohm	5% 0.25W MF	

S T U D E R (04) 84/10/04 TA STEREO-INPUT-4CH/8CH 1.912.250.00 PAGE 8

IND.	POS.NO.	PART NO.	VALUE	SPECIFICATIONS / EQUIVALENT	MANUF.
	R...146	57.11.3392	3.9 kOhm	1% 0.25W MF	
	R...147	57.11.3682	6.8 kOhm	1% 0.25W MF	
	R...148	57.11.3474	470 kOhm	1% 0.25W MF	
(01)	R...149	57.11.3392	3.9 kOhm	1% 0.25W MF	
	R...150	1.912.001.53	47 kOhm	5% neg.log.variable resistor	St
	R...151		47 kOhm	5% neg.log.variable resistor, see R150	St
(01)	R...152	57.11.3392	3.9 kOhm	1% 0.25W MF	
	R...153	57.11.4684	680 kOhm	5% 0.25W MF	
	R...154	57.11.4684	680 kOhm	5% 0.25W MF	
	R...155	57.11.4684	680 kOhm	5% 0.25W MF	
	R...156	57.11.3474	470 kOhm	1% 0.25W MF	
	R...157	57.11.3392	3.9 kOhm	1% 0.25W MF	
	R...158	57.11.3682	6.8 kOhm	1% 0.25W MF	
	R...159	57.11.6106	10 MOhm	10% 0.25W MF	
	R...160	57.11.6106	10 MOhm	10% 0.25W MF	
	R...161	57.11.3153	15 kOhm	1% 0.25W MF	
	R...162	57.11.4472	4.7 kOhm	5% 0.25W MF	
	R...163	57.11.4472	4.7 kOhm	5% 0.25W MF	
	R...164	57.11.4223	22 kOhm	5% 0.25W MF	
	R...165	1.912.001.35	10 kOhm	20% pos.log.variable resistor	St
	R...166	57.11.4682	6.8 kOhm	5% 0.25W MF	
	R...167	57.11.3132	1.3 kOhm	2% 0.25W MF	
	R...168	57.11.4332	3.3 kOhm	5% 0.25W MF	
	R...169	57.11.4472	4.7 kOhm	5% 0.25W MF	
	R...170	57.11.4333	33 kOhm	5% 0.25W MF	
	R...171	57.11.4332	3.3 kOhm	5% 0.25W MF	
	R...172	57.11.4332	3.3 kOhm	5% 0.25W MF	
	R...173	57.11.4333	33 kOhm	5% 0.25W MF	
	R...174	1.912.001.44	10 kOhm	20% pos.log.variable resistor	
	R...175	57.11.4332	3.3 kOhm	5% 0.25W MF	
	R...176	57.11.4104	100 kOhm	5% 0.25W MF	
	R...177	57.11.4332	3.3 kOhm	5% 0.25W MF	
	R...178	57.11.4104	100 kOhm	5% 0.25W MF	
	R...179	57.11.4104	100 kOhm	5% 0.25W MF	
	R...180	57.11.4104	100 kOhm	5% 0.25W MF	
	R...181	57.11.4104	100 kOhm	5% 0.25W MF	
	R...182	57.11.4332	3.3 kOhm	5% 0.25W MF	

S T U D E R (04) 84/10/04 TA STEREO-INPUT-4CH/8CH 1.912.250.00 PAGE 9

IND.	POS.NO.	PART NO.	VALUE	SPECIFICATIONS / EQUIVALENT	MANUF.
	R...183	57.11.4104	100 kOhm	5% 0.25W MF	
	R...184	57.11.4104	100 kOhm	5% 0.25W MF	
	R...185	57.11.4104	100 kOhm	5% 0.25W MF	
	R...186	57.11.4104	*100 kOhm	5% 0.25W MF	
	R...187	57.11.4332	*3.3 kOhm	5% 0.25W MF	
	R...188	57.11.4104	*100 kOhm	5% 0.25W MF	
	R...189	57.11.4104	*100 kOhm	5% 0.25W MF	
	R...190	57.11.4104	*100 kOhm	5% 0.25W MF	
	R...191	57.11.4104	*100 kOhm	5% 0.25W MF	
	R...192	57.11.4332	*3.3 kOhm	5% 0.25W MF	
	R...193	57.11.4104	*100 kOhm	5% 0.25W MF	
	R...194	57.11.4104	*100 kOhm	5% 0.25W MF	
	R...195	57.11.4104	*100 kOhm	5% 0.25W MF	
	R...196		not used		
	R...197	57.11.4103	10 kOhm	5% 0.25W MF	
	R...198	57.11.4104	100 kOhm	5% 0.25W MF	
	R...199	57.11.4104	100 kOhm	5% 0.25W MF	
	R...200	57.11.4103	10 kOhm	5% 0.25W MF	
	R...201	57.11.4104	100 kOhm	5% 0.25W MF	
	R...202	57.11.4104	100 kOhm	5% 0.25W MF	
	R...203	57.11.4104	100 kOhm	5% 0.25W MF	
	R...204	57.11.4330	33 Ohm	5% 0.25W MF	
	R...205		1.8 kOhm	5% 0.25W MF	57114182 optional 2
(01)	R...206		not used		
(01)	R...207	57.11.4109	1 Ohm	5% 0.25W MF	
	R...301	57.11.3472	4.7 kOhm	1% 0.25W MF	
	R...302	57.11.3332	3.3 kOhm	1% 0.25W MF	
	R...303	57.11.3472	4.7 kOhm	1% 0.25W MF	
	R...304	57.11.3332	3.3 kOhm	1% 0.25W MF	
	R...305	57.11.4223	22 kOhm	5% 0.25W MF	
	R...306	57.11.6106	10 MOhm	10% 0.25W MF	
	R...307	57.11.6106	10 MOhm	10% 0.25W MF	
	R...308	57.11.6106	10 MOhm	10% 0.25W MF	
	R...309	57.11.4103	10 kOhm	5% 0.25W MF	
	R...310	57.11.4223	22 kOhm	5% 0.25W MF	
	R...311	57.11.3472	4.7 kOhm	1% 0.25W MF	
	R...312	57.11.4561	560 Ohm	2% 0.25W MF	

S T U D E R (04) 84/10/04 TA STEREO-INPUT-4CH/8CH 1.912.250.00 PAGE 10

IND.	POS.NO.	PART NO.	VALUE	SPECIFICATIONS / EQUIVALENT	MANUF.
		R...313	57.11.3271	270 Ohm	1% 0.25W MF
		R...314		10 kOhm	5% pos.log.variable resistor, see R114 St
		R...315	57.11.4223	22 kOhm	5% 0.25W MF
		R...316	57.11.6106	10 MOhm	10% 0.25W MF
		R...317	57.11.3152	1.5 kOhm	1% 0.25W MF
		R...318	57.11.3152	1.5 kOhm	1% 0.25W MF
		R...319	57.11.3392	3.9 kOhm	1% 0.25W MF
		R...320	57.11.3392	3.9 kOhm	1% 0.25W MF
(01)		R...321	57.11.4392	3.9 kOhm	5% 0.25W MF
(01)		R...322	57.11.4472	4.7 kOhm	5% 0.25W MF
(01)		R...323	57.11.4153	15 kOhm	5% 0.25W MF
(01)		R...324	57.11.4331	330 Ohm	5% 0.25W MF
(01)		R...325	58.01.8502	5 kOhm	10% 0.50W trimming resistor
(01)		R...326	57.11.4122	1.2 kOhm	5% 0.25W MF
(01)		R...327	57.11.4222	2.2 kOhm	5% 0.25W MF
		R...328	57.11.4152	1.5 kOhm	5% 0.25W MF
		R...329		10 kOhm	10% lin. variable resistor, see R129 St
		R...330	57.11.4222	2.2 kOhm	5% 0.25W MF
		R...331	57.11.4152	1.5 kOhm	5% 0.25W MF
		R...332	57.11.4223	22 kOhm	5% 0.25W MF
		R...333	57.11.6106	10 MOhm	10% 0.25W MF
(01)		R...334	57.11.4223	22 kOhm	5% 0.25W MF
		R...335	57.11.6106	10 MOhm	10% 0.25W MF
(03)		R...336	57.11.6106	10 MOhm	10% 0.25W MF
(01)		R...337	57.11.4104	100 kOhm	5% 0.25W MF
		R...338	57.11.4105	1 MOhm	5% 0.25W MF
		R...339	57.11.6106	10 MOhm	10% 0.25W MF
		R...340	57.11.4105	1 MOhm	5% 0.25W MF
		R...341	57.11.6106	10 MOhm	10% 0.25W MF
(01)		R...342	57.11.4104	100 kOhm	5% 0.25W MF
(01)		R...343	57.11.4104	100 kOhm	5% 0.25W MF
		R...344	57.11.4223	22 kOhm	5% 0.25W MF
		R...345	57.11.4330	33 Ohm	5% 0.25W MF
		R...346	57.11.3392	3.9 kOhm	1% 0.25W MF
		R...347	57.11.3682	6.8 kOhm	1% 0.25W MF
		R...348	57.11.3474	470 kOhm	1% 0.25W MF
(01)		R...349	57.11.3392	3.9 kOhm	1% 0.25W MF

S T U D E R (04) 84/10/04 TA STEREO-INPUT-4CH/8CH 1.912.250.00 PAGE 11

IND.	POS.NO.	PART NO.	VALUE	SPECIFICATIONS / EQUIVALENT	MANUF.
		R...350		47 kOhm	5% neg.log.variable resistor, see R150 St
		R...351		47 kOhm	5% neg.log.variable resistor, see R150 St
(01)		R...352	57.11.3392	3.9 kOhm	1% 0.25W MF
		R...353	57.11.4684	680 kOhm	5% 0.25W MF
		R...354	57.11.4684	680 kOhm	5% 0.25W MF
		R...355	57.11.4684	680 kOhm	5% 0.25W MF
		R...356	57.11.3474	470 kOhm	1% 0.25W MF
		R...357	57.11.3392	3.9 kOhm	1% 0.25W MF
		R...358	57.11.3682	6.8 kOhm	1% 0.25W MF
		R...359	57.11.6106	10 MOhm	10% 0.25W MF
		R...360	57.11.6106	10 MOhm	10% 0.25W MF
		R...361	57.11.3153	15 kOhm	1% 0.25W MF
		R...362	57.11.4472	4.7 kOhm	5% 0.25W MF
		R...363	57.11.4472	4.7 kOhm	5% 0.25W MF
		R...364	57.11.4223	22 kOhm	5% 0.25W MF
		R...365		10 kOhm	10% neg.log.variable resistor, see R165 St
		R...366	57.11.4682	6.8 kOhm	5% 0.25W MF
		R...367	57.11.3132	1.3 kOhm	2% 0.25W MF
		R...368	57.11.4332	3.3 kOhm	5% 0.25W MF
		R...369	57.11.4472	4.7 kOhm	5% 0.25W MF
		R...370	57.11.4333	33 kOhm	5% 0.25W MF
		R...371	57.11.4332	3.3 kOhm	5% 0.25W MF
		R...372	57.11.4332	3.3 kOhm	5% 0.25W MF
		R...373	57.11.4333	33 kOhm	5% 0.25W MF
		R...374		10 kOhm	20% pos.log.variable resistor, see R174
		R...375	57.11.4332	3.3 kOhm	5% 0.25W MF
		R...376	57.11.4104	100 kOhm	5% 0.25W MF
		R...377	57.11.4332	3.3 kOhm	5% 0.25W MF
		R...378	57.11.4104	100 kOhm	5% 0.25W MF
		R...379	57.11.4104	100 kOhm	5% 0.25W MF
		R...380	57.11.4104	100 kOhm	5% 0.25W MF
		R...381	57.11.4104	100 kOhm	5% 0.25W MF
		R...382	57.11.4332	3.3 kOhm	5% 0.25W MF
		R...383	57.11.4104	100 kOhm	5% 0.25W MF
		R...384	57.11.4104	100 kOhm	5% 0.25W MF
		R...385	57.11.4104	100 kOhm	5% 0.25W MF
		R...386	57.11.4104	*100 kOhm	5% 0.25W MF

S T U D E R (04) 84/10/04 TA STEREO-INPUT-4CH/8CH 1.912.250.00 PAGE 12

IND.	POS.NO.	PART NO.	VALUE	SPECIFICATIONS / EQUIVALENT	MANUF.
	R...387	57.11.4332	*3.3 kOhm	5% 0.25W MF	
	R...388	57.11.4104	*100 kOhm	5% 0.25W MF	
	R...389	57.11.4104	*100 kOhm	5% 0.25W MF	
	R...390	57.11.4104	*100 kOhm	5% 0.25W MF	
	R...391	57.11.4104	*100 kOhm	5% 0.25W MF	
	R...392	57.11.4332	*3.3 kOhm	5% 0.25W MF	
	R...393	57.11.4104	*100 kOhm	5% 0.25W MF	
	R...394	57.11.4104	*100 kOhm	5% 0.25W MF	
	R...395	57.11.4104	*100 kOhm	5% 0.25W MF	
	R...396		not used		
	R...397	57.11.4103	10 kOhm	5% 0.25W MF	
	R...398	57.11.4104	100 kOhm	5% 0.25W MF	
	R...399	57.11.4104	100 kOhm	5% 0.25W MF	
	R...400	57.11.4103	10 kOhm	5% 0.25W MF	
	R...401	57.11.4104	100 kOhm	5% 0.25W MF	
	R...402	57.11.4104	100 kOhm	5% 0.25W MF	
	R...403	57.11.4104	100 kOhm	5% 0.25W MF	
	R...404	57.11.4330	33 Ohm	5% 0.25W MF	
	R...405		1.8 kOhm	5% 0.25W MF	57114182 option 2
(01)	R...406		not used		
(01)	R...407	57.11.4109	1 Ohm	5% 0.25W MF	
	R...501	57.11.4104	100 kOhm	5% 0.25W MF	
	R...502	57.11.4474	470 kOhm	5% 0.25W MF	
	R...503	57.11.4105	1 MOhm	5% 0.25W MF	
	R...504	57.11.4105	1 MOhm	5% 0.25W MF	
	R...505	57.11.4104	100 kOhm	5% 0.25W MF	
	R...506	57.11.4474	470 kOhm	5% 0.25W MF	
	R...507	57.11.4105	1 MOhm	5% 0.25W MF	
	R...508	57.11.4104	100 kOhm	5% 0.25W MF	
	R...509	57.11.4474	470 kOhm	5% 0.25W MF	
	R...510	57.11.4105	1 MOhm	5% 0.25W MF	
	R...511	57.11.4104	100 kOhm	5% 0.25W MF	
	R...512	57.11.4474	470 kOhm	5% 0.25W MF	
	R...513	57.11.4105	1 MOhm	5% 0.25W MF	
	R...514	57.11.4104	100 kOhm	5% 0.25W MF	
	R...515	57.11.4104	100 kOhm	5% 0.25W MF	
	R...516	57.11.3472	4.7 kOhm	1% 0.25W MF	

S T U D E R (04) 84/10/04 TA STEREO-INPUT-4CH/8CH 1.912.250.00 PAGE 13

IND.	POS.NO.	PART NO.	VALUE	SPECIFICATIONS / EQUIVALENT	MANUF.
	R...517	57.11.4154	150 kOhm	2% 0.25W MF	
	R...518	57.11.3472	4.7 kOhm	1% 0.25W MF	
	R...519	57.11.4154	150 kOhm	2% 0.25W MF	
	R...520	57.11.4223	22 kOhm	5% 0.25W MF	
	R...521	57.11.4103	10 kOhm	5% 0.25W MF	
	R...522	57.11.6106	10 MOhm	10% 0.25W MF	
	R...523	57.11.4104	100 kOhm	5% 0.25W MF	
	R...524	57.11.4474	470 kOhm	5% 0.25W MF	
(01)	R...525	57.11.4105	1 MOhm	5% 0.25W MF	
	R...526	57.11.4105	1 MOhm	5% 0.25W MF	
	R...527	57.11.4103	10 kOhm	5% 0.25W MF	
	R...528	57.11.4104	100 kOhm	5% 0.25W MF	
	R...529	57.11.4105	1 MOhm	5% 0.25W MF	
	R...530	57.11.4104	100 kOhm	5% 0.25W MF	
	R...531	57.11.4331	330 Ohm	5% 0.25W MF	
	R...532	57.11.4331	330 Ohm	5% 0.25W MF	
	R...533	57.11.4103	10 kOhm	5% 0.25W MF	
	R...534	57.11.4335	3.3 MOhm	5% 0.25W MF	
	R...535	57.11.4103	10 kOhm	5% 0.25W MF	
	R...536	57.11.4331	330 Ohm	5% 0.25W MF	
	R...537	57.11.4104	100 kOhm	5% 0.25W MF	
	R...538	57.11.4105	1 MOhm	5% 0.25W MF	
	R...539	57.11.4104	100 kOhm	5% 0.25W MF	
	R...540	57.11.4104	100 kOhm	5% 0.25W MF	
	R...541	57.11.4104	100 kOhm	5% 0.25W MF	
	R...542	57.11.4104	100 kOhm	5% 0.25W MF	
	R...543	57.11.4104	100 kOhm	5% 0.25W MF	
	R...544	57.11.4105	1 MOhm	5% 0.25W MF	
	R...545	57.11.4473	47 kOhm	5% 0.25W MF	
	R...546	57.11.4331	330 Ohm	5% 0.25W MF	
	R...547		not used		
	R...548	57.11.4331	330 Ohm	5% 0.25W MF	
	R...549		not used		
	R...550	57.11.4332	3.3 kOhm	5% 0.25W MF	
	R...551	57.11.4223	22 kOhm	5% 0.25W MF	
	R...552	57.11.4223	22 kOhm	5% 0.25W MF	
	R...553	57.11.4393	39 kOhm	5% 0.25W MF	

S T U D E R (04) 84/10/04 TA STEREO-INPUT-4CH/8CH 1.912.250.00 PAGE 14

IND.	POS.NO.	PART NO.	VALUE	SPECIFICATIONS / EQUIVALENT	MANUF.
	R...554	57.11.3362	3.6 kOhm	5% 0.25W MF	
	R...555	1.912.001.42	10 kOhm	20% pos.log.variable resistor	St
	R...556	57.11.4332	3.3 kOhm	5% 0.25W MF	
	R...557	1.912.001.42	10 kOhm	20% pos.log.variable resistor	St
	R...558	57.11.4332	3.3 kOhm	5% 0.25W MF	
	R...559	1.912.001.42	10 kOhm	20% pos.log.variable resistor	St
	R...560	57.11.4332	3.3 kOhm	5% 0.25W MF	
	R...561	57.11.4102	1 kOhm	5% 0.25W MF	
(01)	R...562	57.11.4681	680 Ohm	5% 0.25W MF	
	R...563	57.11.4471	470 Ohm	5% 0.25W MF	
	R...564	57.99.0206	50 Ohm	PTC Philips Nr.2322 662	91008
	R...565	57.99.0209	5.6 Ohm	PTC Philips Nr.2322 662	91005
	R...566	57.99.0209	5.6 Ohm	PTC Philips Nr.2322 662	91005
	R...567	57.99.0209	5.6 Ohm	PTC Philips Nr.2322 662	91005
	R...568				
	R...569				
	S...101		2*U	3u gold 5515003 option2	ITT
	S...102		not used		
	S...103	55.15.0004	4*U	3u gold button: 55030303 red	ITT
	S...104		2*U	combined with variable resistor R 174	St
	S...105	55.15.0002	2*U	button: 55030303 red	ITT
	S...106	55.15.0002	2*U	button: 55030303 red	ITT
	S...107	55.15.0002	* 2*U	button: 55030303 red	ITT
	S...108	55.15.0002	* 2*U	button: 55030303 red	ITT
	S...301		2*U	3u gold see S101	
	S...302		not used		
	S...303		4*U	3u gold see S103	
	S...304		2*U	combined with variable resistor R 174	St
	S...305		2*U	55150012 option1	ITT
	S...306		2*U	55150012 option1	ITT
	S...307		2*U	55150012 option1	ITT
	S...308		2*U	55150012 option1	ITT
	S...501		1*U	toggle-switch 55010159 dialight,CK	
	S...502		2*4	rotary-switch 55130003	St
	S...503		1*U	toggle-switch 55010159 dialight,CK	
	S...504		1*U	combined with variable resistor R 150	St

S T U D E R (04) 84/10/04 TA STEREO-INPUT-4CH/8CH 1.912.250.00 PAGE 15

IND.	POS.NO.	PART NO.	VALUE	SPECIFICATIONS / EQUIVALENT	MANUF.
	S...505		1*U	see 1.911.001.00	
	S...506		1*U	see 1.911.001.00	
	S...507		1*U	combined with variable resistor R 555	St
	S...508		1*U	combined with variable resistor R 557	St
	S...509		1*U	combined with variable resistor R 559	St
	T...101	1.022.451.00		input trafo 1:0.62	St
	T...301	1.022.451.00		input trafo 1:0.62	St

=====
 * ONLY 8-CHANNEL
 =====

(01) 29.06.83 quality improvement
 (02) 15.09.83 improvement of low frequency noise
 (03) 27.02.84
 (04) 04.10.84 suppression of high frequency

optional 1: 8-switches for 8-master-select

optional 2: with equalizer pcb

CE=Ceramic, CF=Carbon Film, EL=Electrolytic, MF=Metal Film,
 PE=Polyester, PP=Polypropylen, PS=Polystyrol

MANUFACTURER: Bu=Burndy, Ex=Exar, Fc=Fairchild, GI=General Instrument
 HP=Hewlett Packard, ITT=Intermetall, Mot=Motorola,
 NS=National Semiconductors, Ph=Philips, Ra=Raytheon,
 Sig=Signetics, Six=Siliconix, St=Studer,
 TI=Texas Instrument, CK=C&K

ORIG 83/03/23 (01) 83/06/29 (02) 83/09/15 (03) 84/02/27 (04) 84/10/04

S T U D E R (04) 84/10/04 TA STEREO-INPUT-4CH/8CH 1.912.250.00 PAGE 16

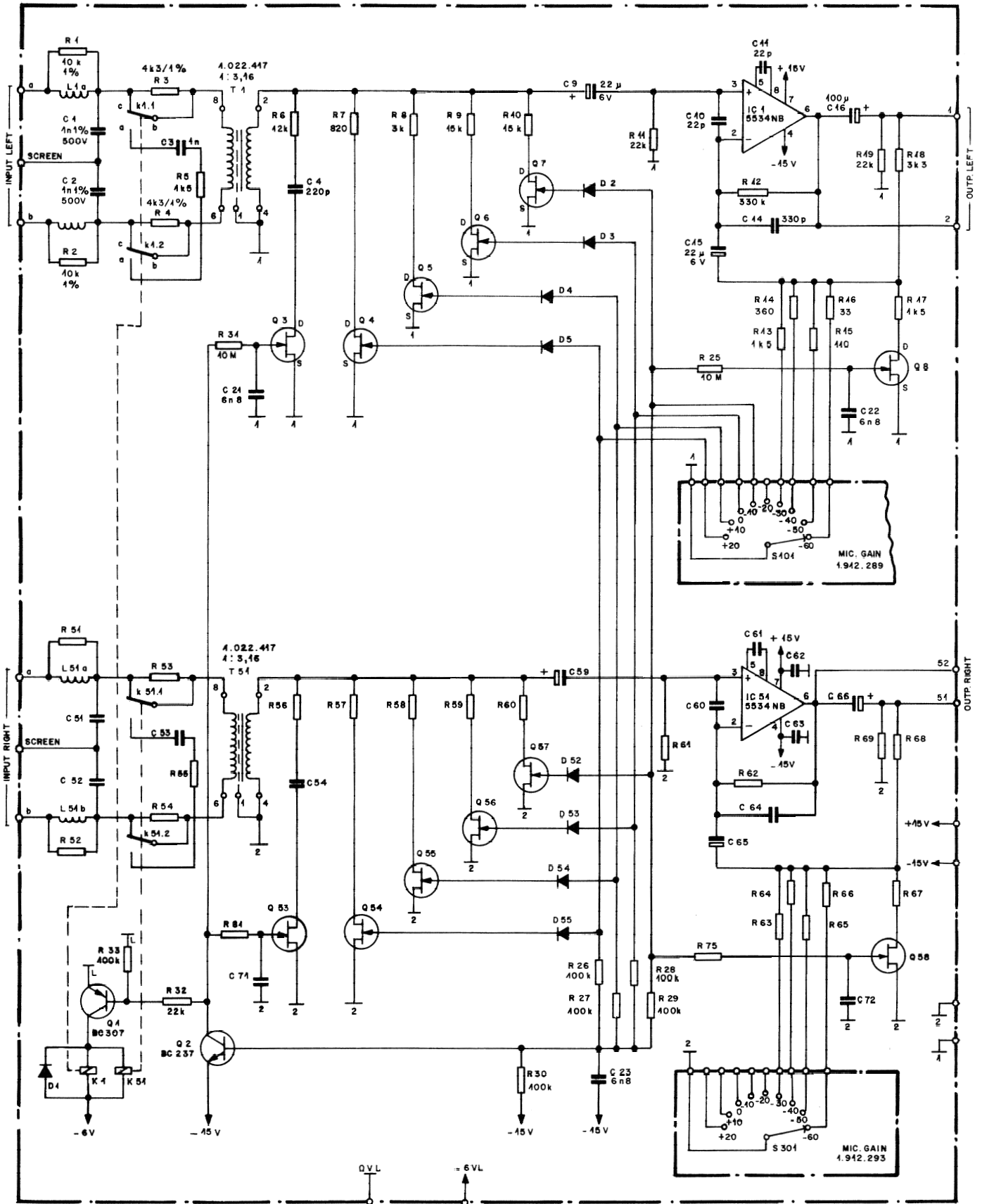

ALL D = 1N 4448

ALL FET = J442

POS. NR.: 4... 49 LEFT
54... 99 RIGHT

DATE:	26.10.85			
SIGN:	<i>ml</i>			
STUDER REGENSDORF ZÜRICH	STEREO MIC. AMPLIFIER			SC 1.912.292

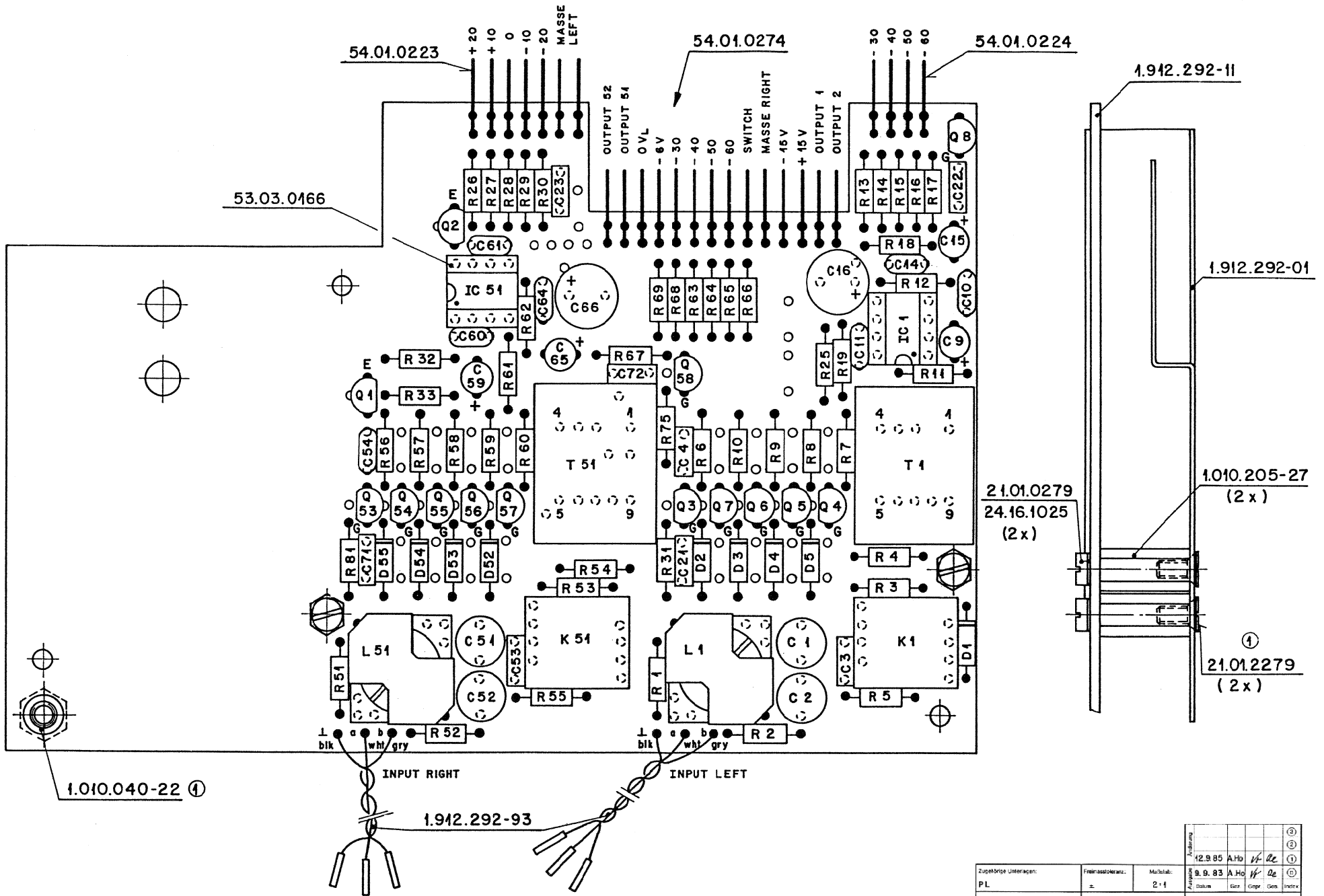

Zusätzliche Unterlagen:		Freiassoziation:	Multibit:	Arbeitsjahr:	Arbeitsort:	Arbeitsnummer:	Arbeitsdatum:	Arbeitsgruppe:	Arbeitsleiter:	Arbeitsassistent:	Arbeitskontrolle:
PL		±	2+1	9.9.83	A.Ho	PL	De	Ge	Ge	Ge	Ge
Erstellt für:		Erstellt durch:		Kopie für:		Arbeitsnummer:		Arbeitsdatum:		Arbeitsgruppe:	
STUDIER REGENERATOR ZÜRICH		Stereo Mic Amplifier		Kopie für:		Arbeitsnummer:		Arbeitsdatum:		Arbeitsgruppe:	
				1.912.292-00							

IND.	POS.NO.	PART NO.	VALUE	SPECIFICATIONS / EQUIVALENT	MANUF.
	C.....1	59.05.1102	1 nF	1% 500V PP	
	C.....2	59.05.1102	1 nF	1% 500V PP	
	C.....3	59.06.0102	1 nF	10% 50V PE	
	C.....4	59.34.4221	220 pF	5% CE	
	C.....5		not used		
	C.....6		not used		
	C.....7		not used		
	C.....8		not used		
	C.....9	59.30.2220	22 uF	-20% 6.3V TA	
	C.....10	59.34.2220	22 pF	5% CE	
	C.....11	59.34.2220	22 pF	5% CE	
	C.....14	59.34.4331	330 pF	5% CE	
	C.....15	59.30.2220	22 uF	-20% 6.3V TA	
(01)	C.....16	59.22.3101	100 uF	-20% 10V EL	
	C.....17		not used		
	C.....18		not used		
	C.....19		not used		
	C.....20		not used		
	C.....21	59.06.0682	6.8 nF	10% 50V PE	
	C.....22	59.06.0682	6.8 nF	10% 50V PE	
	C.....23	59.06.0682	6.8 nF	10% 50V PE	
	C.....24		not used		
	C.....25		not used		
	C.....51	59.05.1102	1 nF	1% 500V PP	
	C.....52	59.05.1102	1 nF	1% 500V PP	
	C.....53	59.06.0102	1 nF	10% 50V PE	
	C.....54	59.34.4221	220 pF	5% CE	
	C.....55		not used		
	C.....56		not used		
	C.....57		not used		
	C.....58		not used		
	C.....59	59.30.2220	22 uF	-20% 6.3V TA	
	C.....60	59.34.2220	22 pF	5% CE	
	C.....61	59.34.2220	22 pF	5% CE	
	C.....62		not used		
	C.....63		not used		
	C.....64	59.34.4331	330 pF	5% CE	
	C.....65	59.30.2220	22 uF	-20% 6.3V TA	
	C.....66	59.22.4101	100 uF	-20% 16V EL	
	C.....67		not used		
	C.....68		not used		
	C.....69		not used		
	C.....70		not used		
	C.....71	59.06.0682	6.8 nF	10% 50V PE	
	C.....72	59.06.0682	6.8 nF	10% 50V PE	
	D.....1	50.04.0125	1N4448		any
	D.....2	50.04.0125	1N4448		any
	D.....3	50.04.0125	1N4448		any
	D.....4	50.04.0125	1N4448		any
	D.....5	50.04.0125	1N4448		any
	D.....52	50.04.0125	1N4448		any
	D.....53	50.04.0125	1N4448		any
	D.....54	50.04.0125	1N4448		any
	D.....55	50.04.0125	1N4448		any
	IC.....1	50.05.0244	NE5534AN	single op. amp. low noise	Ti,Sig,Ra
	IC.....51	50.05.0244	NE5534AN	single op. amp. low noise	Ti,Sig,Ra
	K.....1	56.04.0170	5 V	relais	
	K.....51	56.04.0170	5 V	relais	
	L.....1	1.022.207.00		HF-sym. coil	
	L.....51	1.022.207.00		HF-sym. coil	
	Q.....1	50.03.0515	BC 307	PNP IC>100mA, B>100	any
	Q.....2	50.03.0436	BC 237	NPN IC>100mA, B>100	any
	Q.....3	50.03.0350	J 112	N-JFET	NS,Mot,Six
	Q.....4	50.03.0350	J 112	N-JFET	NS,Mot,Six
	Q.....5	50.03.0350	J 112	N-JFET	NS,Mot,Six
	Q.....6	50.03.0350	J 112	N-JFET	NS,Mot,Six
	Q.....7	50.03.0350	J 112	N-JFET	NS,Mot,Six
	Q.....8	50.03.0350	J 112	N-JFET	NS,Mot,Six
	Q.....53	50.03.0350	J 112	N-JFET	NS,Mot,Six

IND.	POS.NO.	PART NO.	VALUE	SPECIFICATIONS / EQUIVALENT	MANUF.
	Q.....54	50.03.0350	J 112	N-JFET	NS,Mot,Six
	Q.....55	50.03.0350	J 112	N-JFET	NS,Mot,Six
	Q.....56	50.03.0350	J 112	N-JFET	NS,Mot,Six
	Q.....57	50.03.0350	J 112	N-JFET	NS,Mot,Six
	Q.....58	50.03.0350	J 112	N-JFET	NS,Mot,Six
	R.....1	57.11.3103	10 kOhm	1% 0.25W MF	
	R.....2	57.11.3103	10 kOhm	1% 0.25W MF	
	R.....3	57.11.3432	4.3 kOhm	1% 0.25W MF	
	R.....4	57.11.3432	4.3 kOhm	1% 0.25W MF	
	R.....5	57.11.4152	1.5 kOhm	5% 0.25W MF	
	R.....6	57.11.4123	12 kOhm	5% 0.25W MF	
	R.....7	57.11.4821	820 Ohm	2% 0.25W MF	
	R.....8	57.11.3302	3 kOhm	2% 0.25W MF	
	R.....9	57.11.4153	15 kOhm	2% 0.25W MF	
	R.....10	57.11.4153	15 kOhm	2% 0.25W MF	
	R.....11	57.11.4223	22 kOhm	5% 0.25W MF	
	R.....12	57.11.4334	330 kOhm	5% 0.25W MF	
	R.....13	57.11.4152	1.5 kOhm	2% 0.25W MF	
	R.....14	57.11.3361	360 Ohm	2% 0.25W MF	
	R.....15	57.11.3111	110 Ohm	2% 0.25W MF	
	R.....16	57.11.4330	33 Ohm	2% 0.25W MF	
	R.....17	57.11.4152	1.5 kOhm	2% 0.25W MF	
	R.....18	57.11.3332	3.3 kOhm	2% 0.25W MF	
	R.....19	57.11.4223	22 kOhm	5% 0.25W MF	
	R.....21		not used		
	R.....22		not used		
	R.....23		not used		
	R.....24		not used		
	R.....25	57.11.6106	10 MOhm	10% 0.25W MF	
	R.....26	57.11.4104	100 kOhm	5% 0.25W MF	
	R.....27	57.11.4104	100 kOhm	5% 0.25W MF	
	R.....28	57.11.4104	100 kOhm	5% 0.25W MF	
	R.....29	57.11.4104	100 kOhm	5% 0.25W MF	
	R.....30	57.11.4104	100 kOhm	5% 0.25W MF	
	R.....31	57.11.6106	10 MOhm	10% 0.25W MF	
	R.....32	57.11.4223	22 kOhm	5% 0.25W MF	eventuell kleiner
	R.....33	57.11.4104	100 kOhm	5% 0.25W MF	
	R.....51	57.11.3103	10 kOhm	1% 0.25W MF	
	R.....52	57.11.3103	10 kOhm	1% 0.25W MF	
	R.....53	57.11.3432	4.3 kOhm	1% 0.25W MF	
	R.....54	57.11.3432	4.3 kOhm	1% 0.25W MF	
	R.....55	57.11.4152	1.5 kOhm	5% 0.25W MF	
	R.....56	57.11.4123	12 kOhm	5% 0.25W MF	
	R.....57	57.11.4821	820 Ohm	2% 0.25W MF	
	R.....58	57.11.3302	3 kOhm	2% 0.25W MF	
	R.....59	57.11.4153	15 kOhm	2% 0.25W MF	
	R.....60	57.11.4153	15 kOhm	2% 0.25W MF	
	R.....61	57.11.4223	22 kOhm	5% 0.25W MF	
	R.....62	57.11.4334	330 kOhm	5% 0.25W MF	
	R.....63	57.11.4152	1.5 kOhm	2% 0.25W MF	
	R.....64	57.11.3361	360 Ohm	2% 0.25W MF	
	R.....65	57.11.3111	110 Ohm	2% 0.25W MF	
	R.....66	57.11.4330	33 Ohm	2% 0.25W MF	
	R.....67	57.11.4152	1.5 kOhm	2% 0.25W MF	
	R.....68	57.11.3332	3.3 kOhm	2% 0.25W MF	
	R.....69	57.11.4223	22 kOhm	5% 0.25W MF	
	R.....71		not used		
	R.....72		not used		
	R.....73		not used		
	R.....74		not used		
	R.....75	57.11.6106	10 MOhm	10% 0.25W MF	
	R.....81	57.11.6106	10 MOhm	10% 0.25W MF	
	S.....1		10U	combined with K1	
	S.....2		20U	combined with K1	
	S.....51		10U	combined with K1	
	S.....52		20U	combined with K1	
	T.....1	1.022.417.00		input trafo 1:3.1	
	T.....51	1.022.417.00		input trafo 1:3.1	
	XIC.....	53.03.0166		IC-socket	

CE=Ceramic, CF=Carbon Film, EL=Electrolytic, MF=Metal Film, PE=Polyester, PP=Polypropylen, PS=Polystyrol

MANUFACTURER: Bu=Burndy, Ex=Exar, Fc=Fairchild, GI=General Instrument, HP=Hewlett Packard, ITT=Intermetall, Mot=Motorola, NS=National Semiconductors, Ph=Phillips, Ra=Raytheon, Sig=Signetics, Six=Siliconix, St=Studer, TI=Texas Instrument

ORIG 83/03/29 (1) 14/02/21

S T U D E R 83/03/29 AE MICROPHONE-AMPLIFIER-STEREO 1.912.292.00

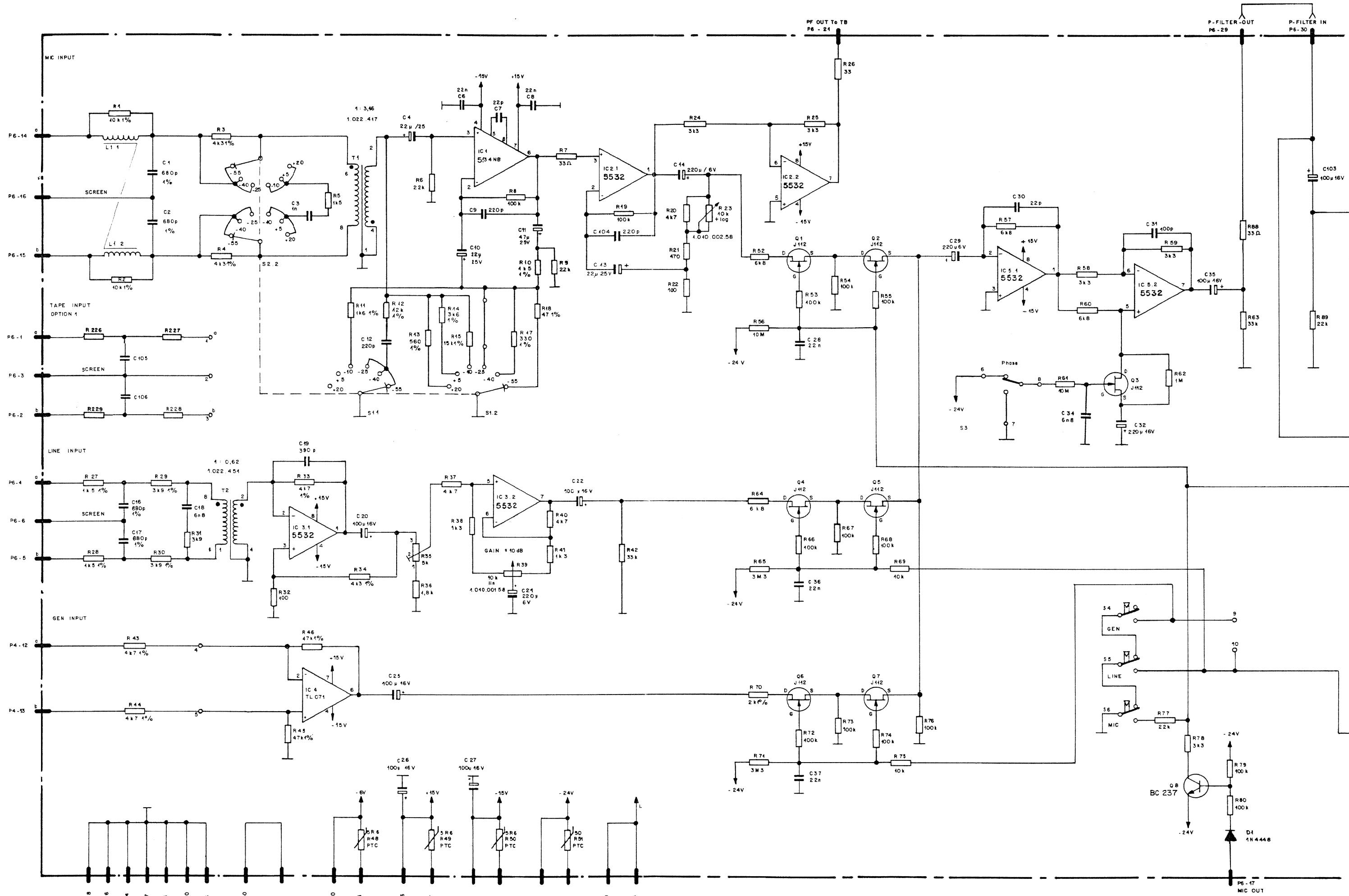

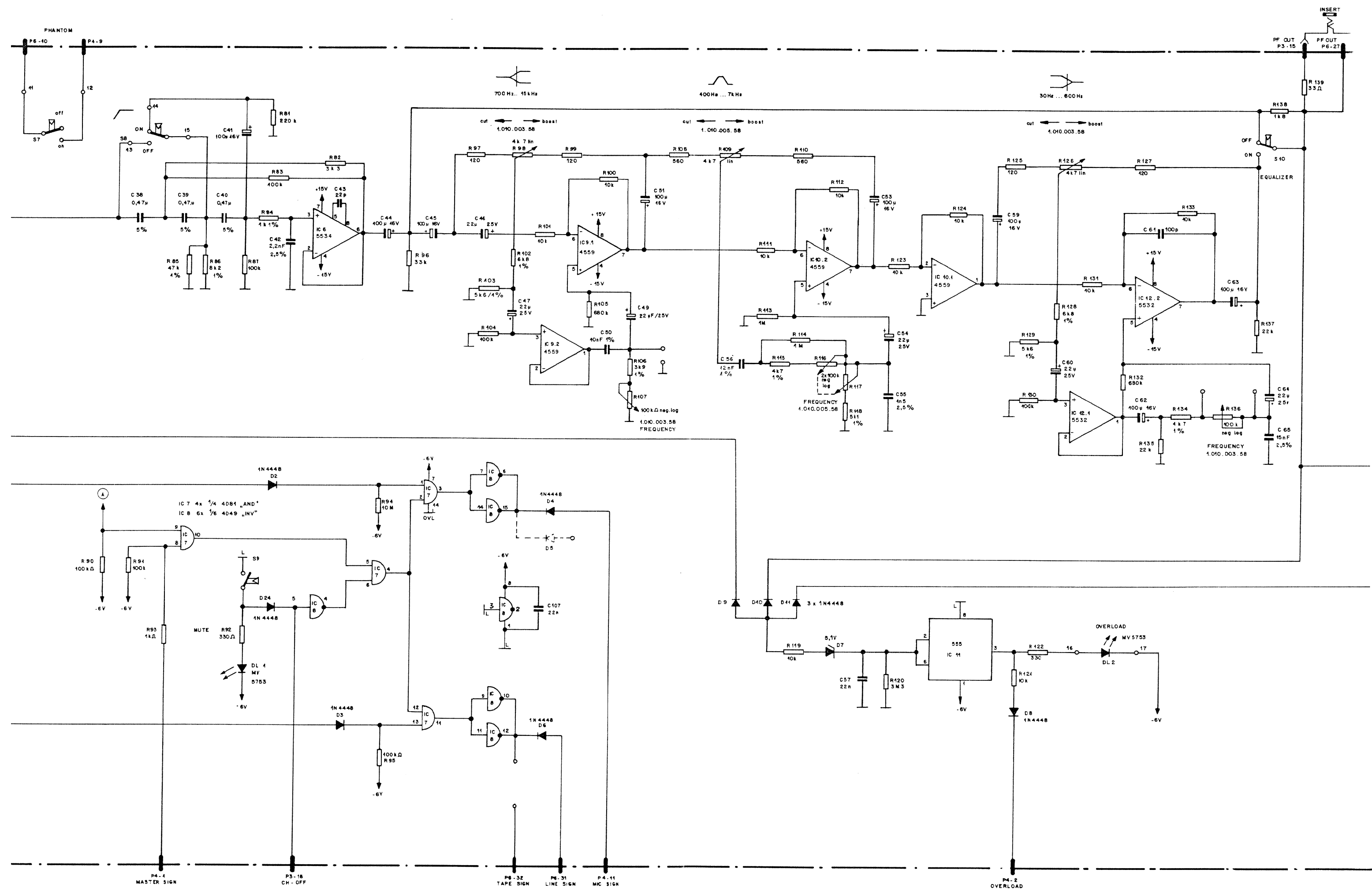

MONO FADER UNIT A 1.944.110
OR
MONO FADER A / BAL. AMP. UNIT 1.944.112

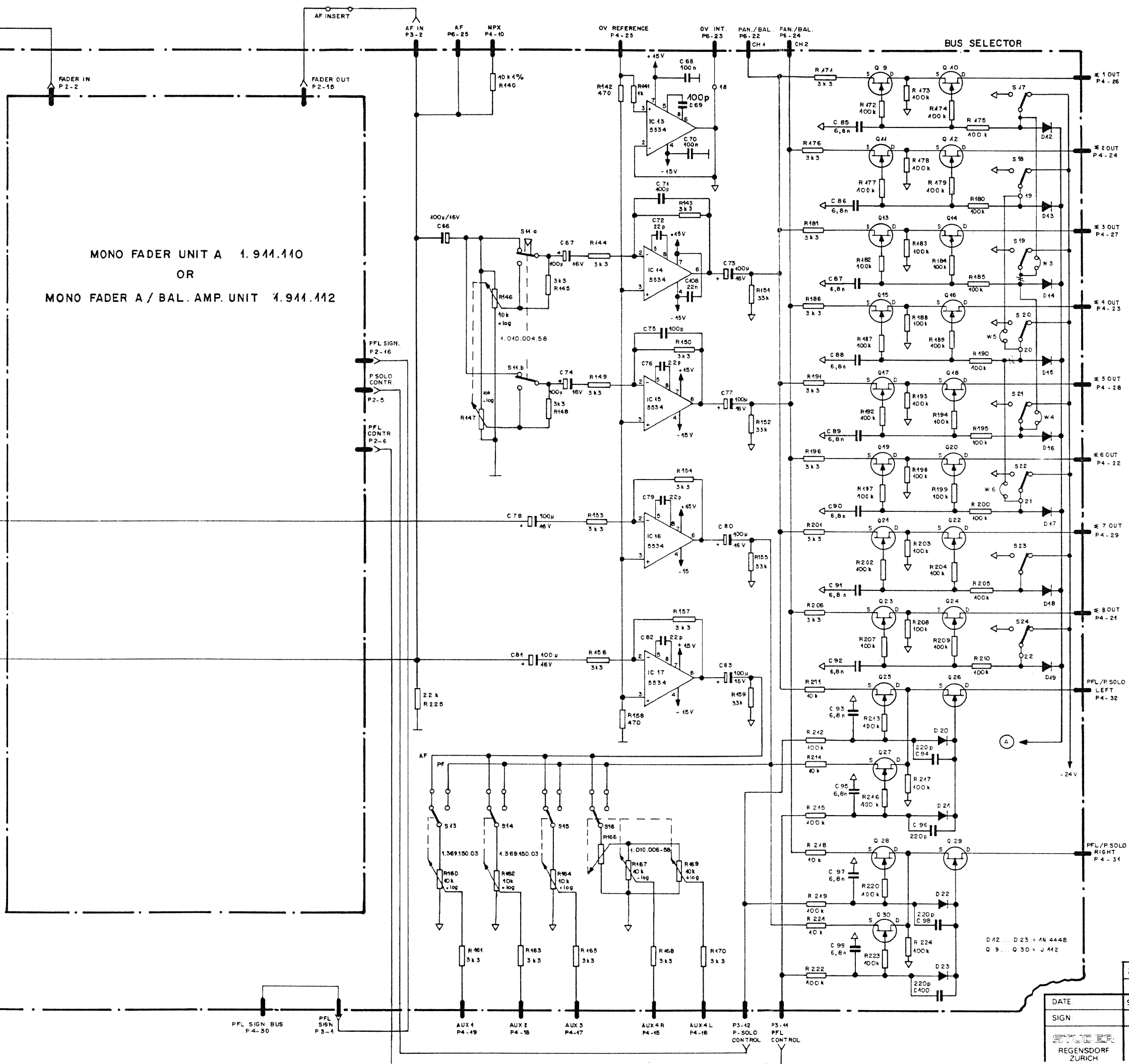

- | | | | | | |
|------------|-----------------------|-----|------------------|-----|-------------------|
| P 6 | 1 TAPE a | P 4 | 1 MASTER SIGN. | P 3 | 1 PFL SIGN. BUS |
| 2 TAPE b | 2 OVERLOAD | 2 | 2 OVERLOAD | 2 | 2 FADER OUT |
| 3 SCREEN | 3 -6 V | 3 | 3 -6 V | 3 | 3 |
| 4 LINE a | 4 OVL | 4 | 4 OVL | 4 | 4 |
| 5 LINE b | 5 -15 V | 5 | 5 -15 V | 5 | 5 -24 V |
| 6 SCREEN | 6 OVA | 6 | 6 OVA | 6 | 6 +45 V |
| 7 | 7 +15 V | 7 | 7 +15 V | 7 | 7 OVA |
| 8 | 8 -24 V | 8 | 8 -24 V | 8 | 8 -45 V |
| 9 | 9 +48 V | 9 | 9 +48 V | 9 | 9 OVL |
| 10 PHANTOM | 10 MPX | 10 | 10 MPX | 10 | 10 -6 V |
| 11 | 11 MIC. SIGN. | 11 | 11 MIC. SIGN. | 11 | 11 PFL CONTR. |
| 12 | 12 GEN. a | 12 | 12 GEN. a | 12 | 12 P. SOLO CONTR. |
| 13 | 13 GEN. b | 13 | 13 GEN. b | 13 | 13 |
| 14 | 14 MIC. a | 14 | 14 MIC. a | 14 | 14 OVA LEFT |
| 15 | 15 MIC. b | 15 | 15 AUX 4 R OUT | 15 | 15 FADER INP. |
| 16 | 16 SCREEN | 16 | 16 AUX 4 L OUT | 16 | 16 |
| 17 | 17 MIC. CUT | 17 | 17 AUX 3 OUT | 17 | 17 |
| 18 | 18 | 18 | 18 AUX 2 OUT | 18 | 18 |
| 19 | 19 | 19 | 19 AUX 1 OUT | 19 | 19 |
| 20 | 20 | 20 | 20 OVA | 20 | 20 |
| 21 | 21 PF OUT TO TB. | 21 | 21 8 OUT | 21 | 21 |
| 22 | 22 CH 1 PAN./BAL. | 22 | 22 6 OUT | 22 | 22 |
| 23 | 23 OV INT. | 23 | 23 4 OUT | 23 | 23 |
| 24 | 24 CH 2 PAN./BAL. | 24 | 24 2 OUT | 24 | 24 |
| 25 | 25 AF OUT | 25 | 25 OV REF | 25 | 25 |
| 26 | 26 OVA | 26 | 26 4 OUT | 26 | 26 |
| 27 | 27 PF OUT | 27 | 27 3 OUT | 27 | 27 |
| 28 | 28 OVA | 28 | 28 5 OUT | 28 | 28 |
| 29 | 29 P-FILTER OUT | 29 | 29 7 OUT | 29 | 29 |
| 30 | 30 P-FILTER IN | 30 | 30 PFL SIGN. BUS | 30 | 30 |
| 31 | 31 LINE SIGN. | 31 | 31 PFL/P SOLO R | 31 | 31 |
| 32 | 32 TAPE SIGN OPTION 1 | 32 | 32 PFL/P SOLO L | 32 | 32 |

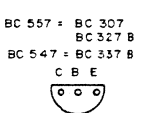
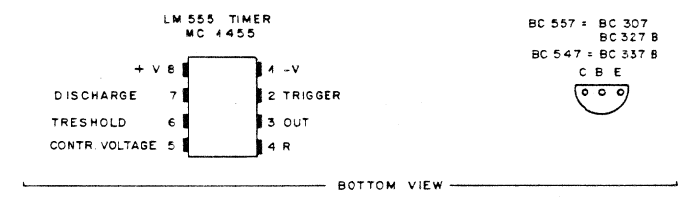
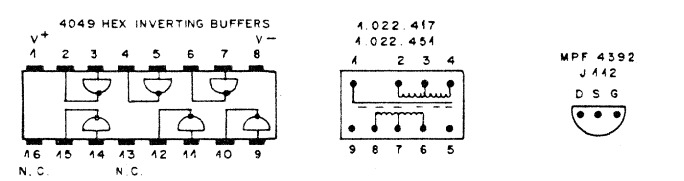
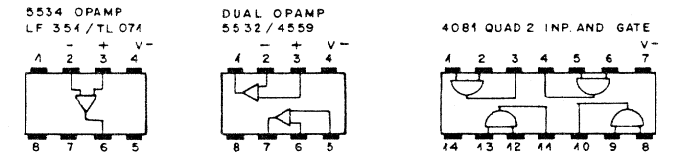

DATE	2 10. 89					
SIGN	<i>Ge</i>	<i>Mc</i>	<i>Ja</i>	<i>Mc</i>	<i>Ul</i>	<i>Ul</i>
	9.9.83	13.12.83	16.12.83	26.2.84	25.5.84	4.10.84
	MONO INPUT B 4CH					SC 1.912.120
	MONO INPUT B 8CH					SC 1.912.122

STÜCKER
REGENSDORF
ZÜRICH

BOTTOM VIEW

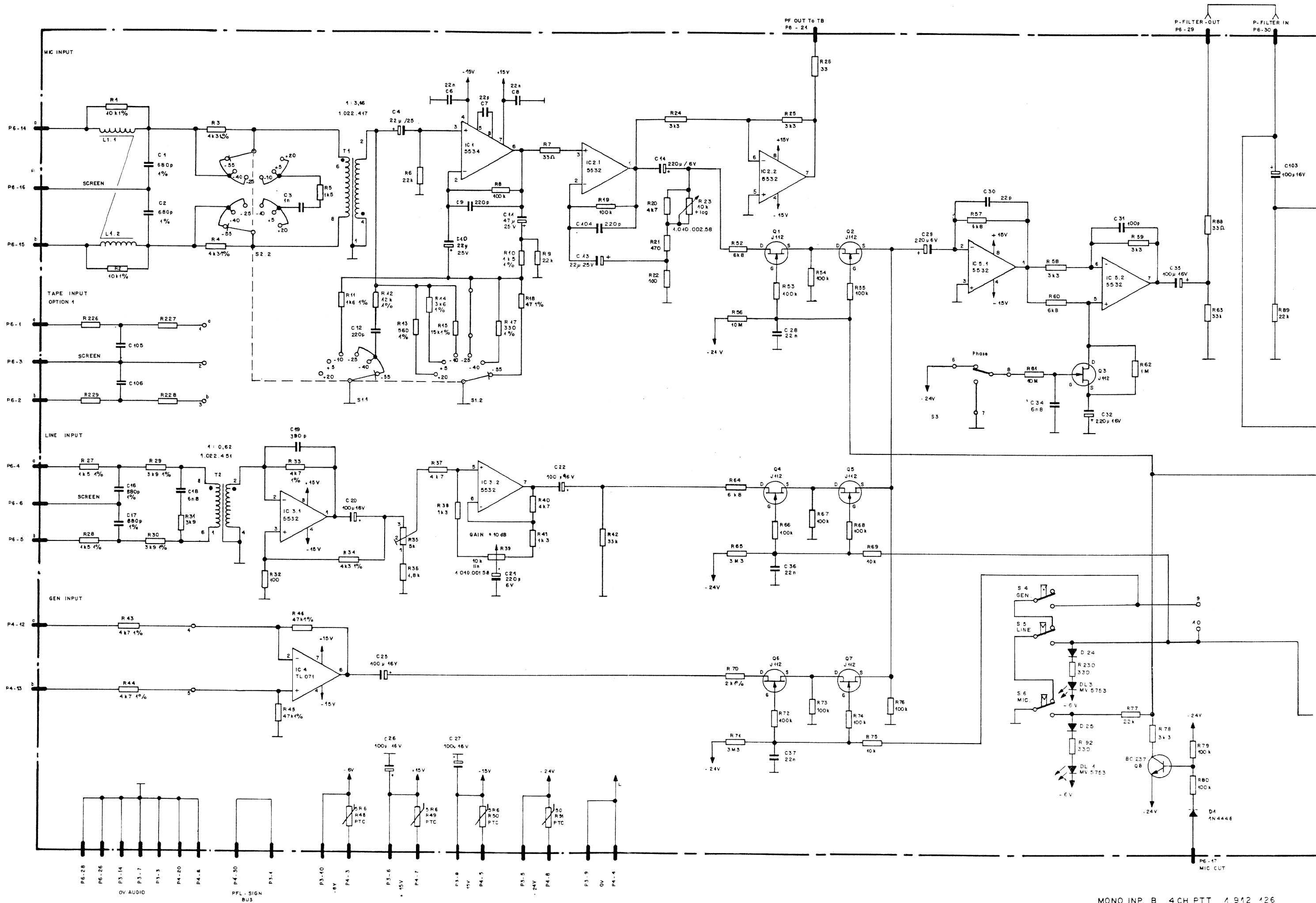

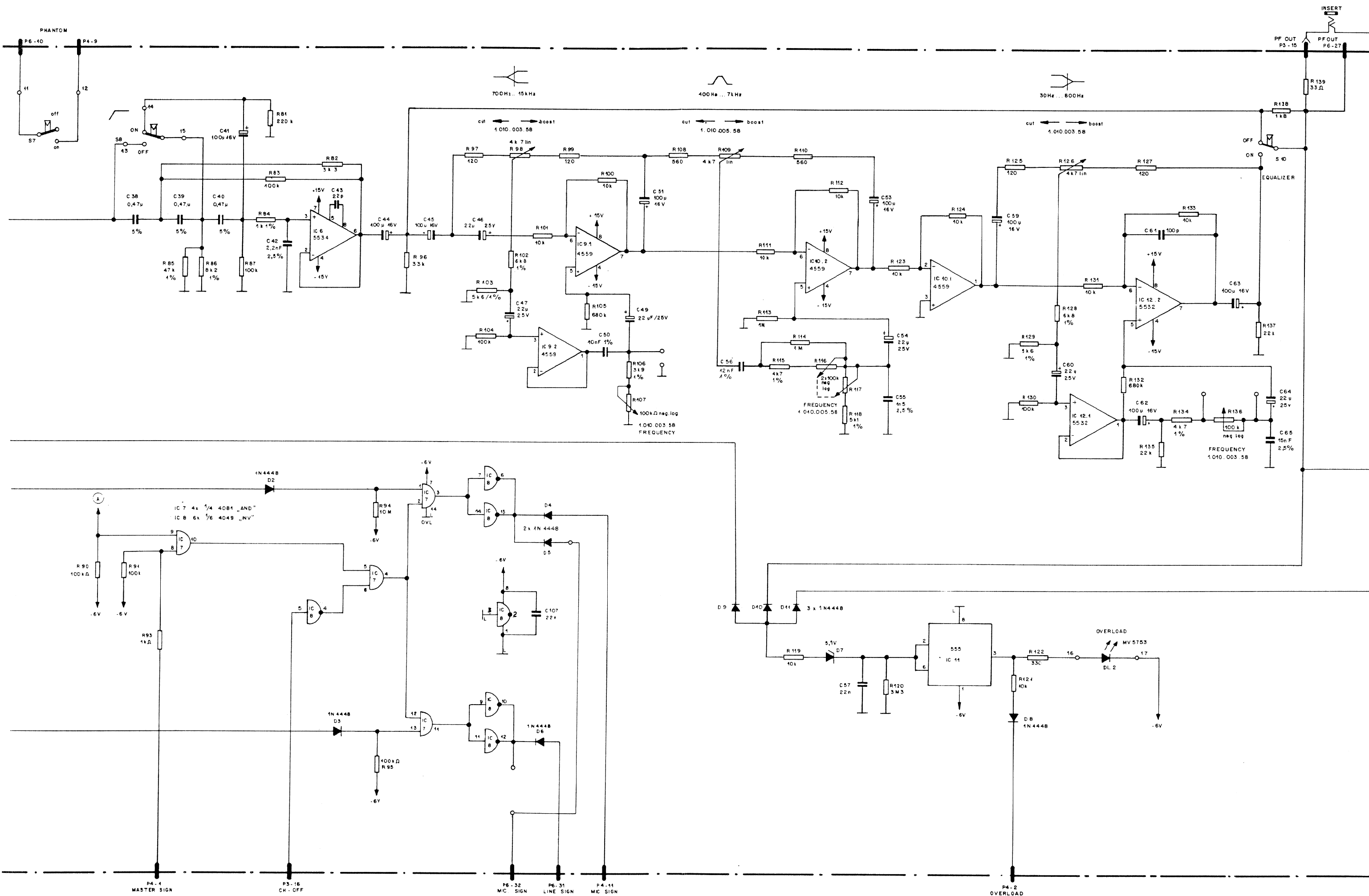

MONO FADER UNIT B 1.911.150
OR
MONO FADER B / BAL. AMP. 1.911.152

BUS SELECTOR

- | | | | | | |
|------------|----------|--------------|-------------------|-------------|----------------|
| P 5 | 1 TAPE a | P 4 | 1 MASTER SIGN. | P 3 | 1 PFL SIGN BUS |
| 2 TAPE b | OPTION 1 | 2 OVERLOAD | 2 FADER OUT | 2 FADER OUT | |
| 3 SCREEN | | 3 -6V | 3 | 3 | |
| 4 LINE a | | 4 DVL | 4 DVL | 4 | |
| 5 LINE b | | 5 -15V | 5 -15V | 5 | |
| 6 SCREEN | | 6 OV A | 6 +15V | 6 | |
| 7 | | 7 +15V | 7 OV A | 7 | |
| 8 | | 8 -24V | 8 -15V | 8 | |
| 9 | | 9 +48V | 9 OV L | 9 | |
| 10 PHANTOM | | 10 MPX | 10 -6V | 10 | |
| 11 | | 11 MIC SIGN. | 11 PFL CONTR. | 11 | |
| 12 | | 12 GEN. a | 12 P. SOLO CONTR. | 12 | |
| 13 | | 13 GEN. b | 13 | 13 | |
| 14 | | 14 MIC. a | 14 | 14 | |
| 15 | | 15 MIC. b | 15 AUX 4 R OUT | 15 | |
| 16 | | 16 SCREEN | 16 AUX 4 L OUT | 16 | |
| 17 | | 17 MIC. OUT | 17 AUX 3 OUT | 17 | |
| 18 | | 18 | 18 AUX 2 OUT | 18 | |
| 19 | | 19 | 19 AUX 1 OUT | 19 | |
| 20 | | 20 | 20 OV A | 20 | |
| 21 | | 21 | 21 8 OUT | 21 | |
| 22 | | 22 | 22 CH 1 PAN / BAL | 22 | |
| 23 | | 23 | 23 4 OUT | 23 | |
| 24 | | 24 | 24 CH 2 PAN / BAL | 24 | |
| 25 | | 25 | 25 OV REF | 25 | |
| 26 | | 26 | 26 1 OUT | 26 | |
| 27 | | 27 | 27 3 OUT | 27 | |
| 28 | | 28 | 28 5 OUT | 28 | |
| 29 | | 29 | 29 7 OUT | 29 | |
| 30 | | 30 | 30 PFL SIGN. BUS | 30 | |
| 31 | | 31 | 31 PFL / P SOLO R | 31 | |
| 32 | | 32 | 32 PFL / P SOLO L | 32 | |

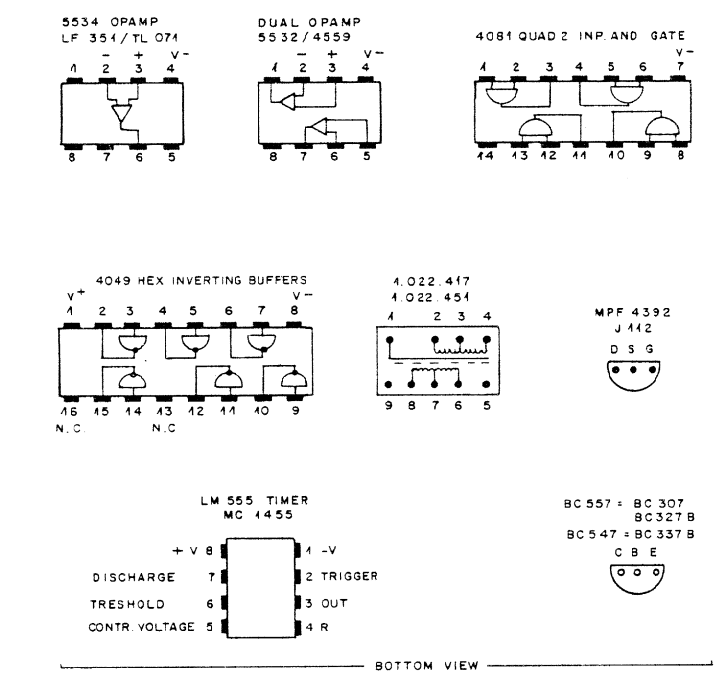

DATE:	8.1.85	2.10.89			
SIGN:	<i>Ge</i>	<i>Ge</i>			PAGE 3 OF 3
STUDER REGENSDORF ZÜRICH			MONO INPUT B 4 CH PTT		SC 1.912.126

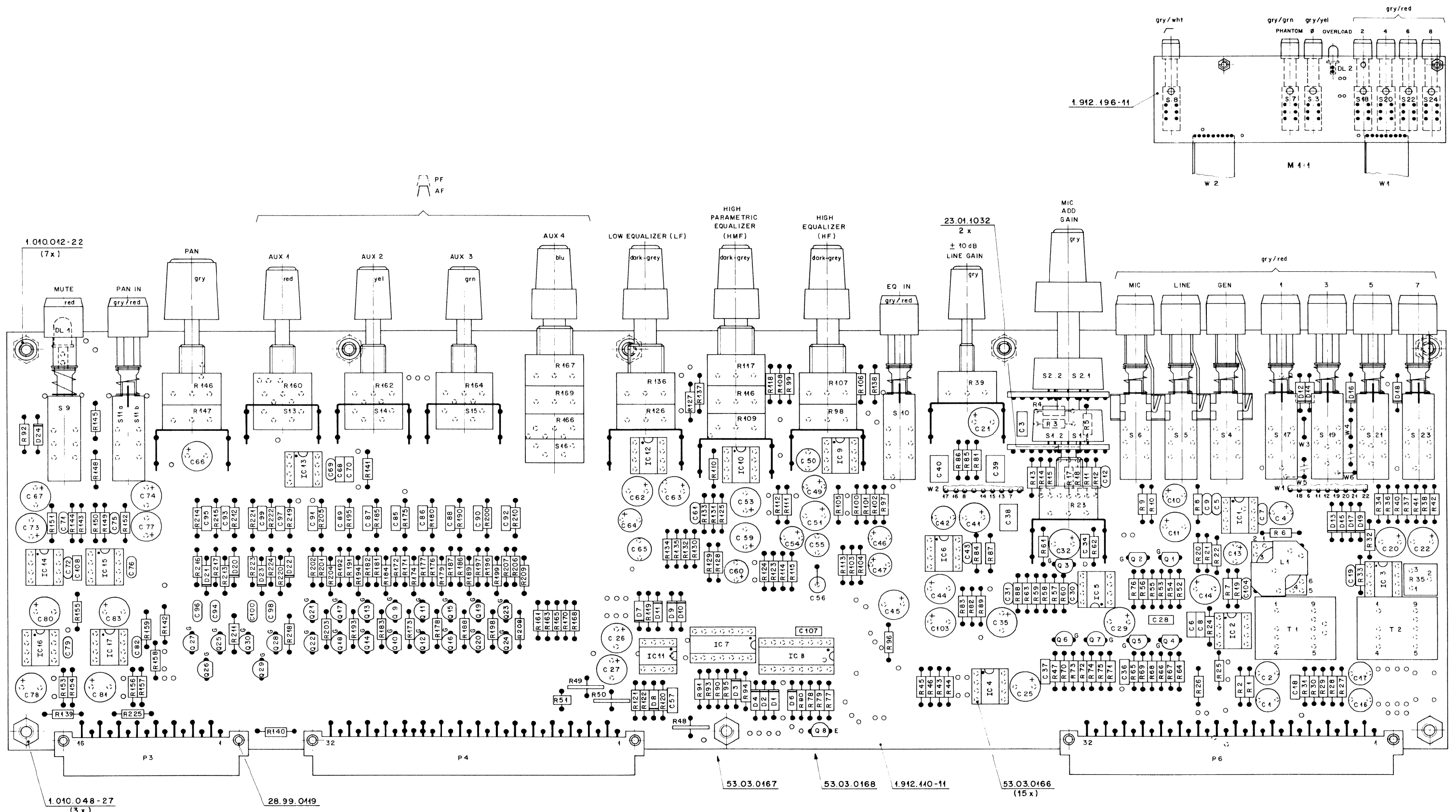

ONLY 4 CH : W3, W4, W5, W6
 // CIRCUIT INTERRUPT SOLDER SIDE

VALID FOR	NR. UNIT	NR. PL
4 CH	1.912.120-00	1.912.120-00
8 CH	1.912.122-00	1.912.120-00

① C 34 was C 33

Werkstoff	Norm-Nr.:	Güte:	Änderung
	DIN-Bez.:	Beh.:	
Zugehörige Unterlagen:	Abmessung:	Fremmasstoleranz:	Maßstab:
Erstausführung:	Erstausführung:	Datum:	Gez., Gepr., Ges. Index
STUDEF REGENSDORF ZÜRICH		Bezeichnung: Mono Input Unit B 4 CH / 8 CH	
		Nummer: 1.912.120-00	

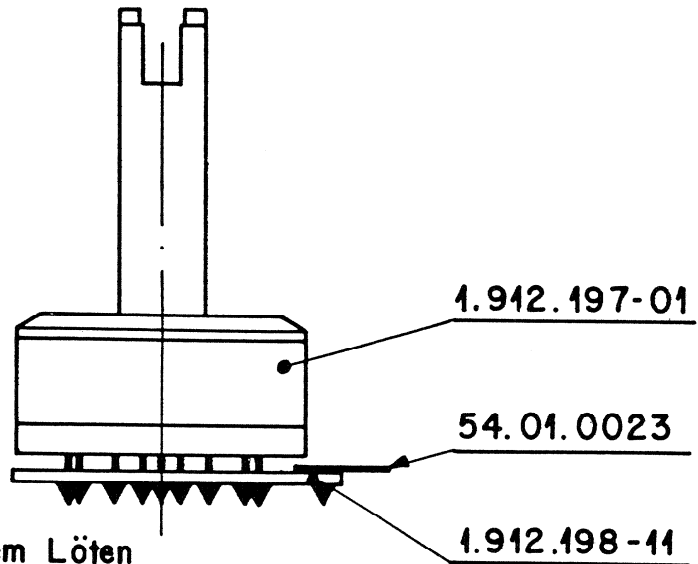

Schalter während dem Lötén
auf Print pressen

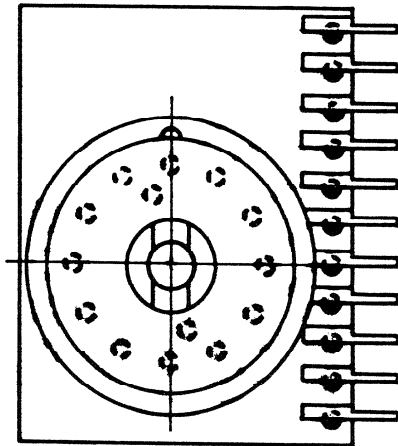

Werkstoff	Norm-Nr.:	Oberfläche	Güte:	Änderung						③	
	DIN-Bez.:		Beh.:								②
	Abmessung:										
Zugehörige Unterlagen:	Freimasstoleranz:	Maßstab:	Ausgabe		6.5.83	A.Ho	✓	✓		④	
Ersatz für:	±	2:1	Datum	Gez.	Gepr.	Ges.	Index				
Ersetzt durch:		Kopie für:									
STUDER REGENSDORF ZÜRICH		Bezeichnung: Switch - Board - B1		Nummer: 1.912.197-00							

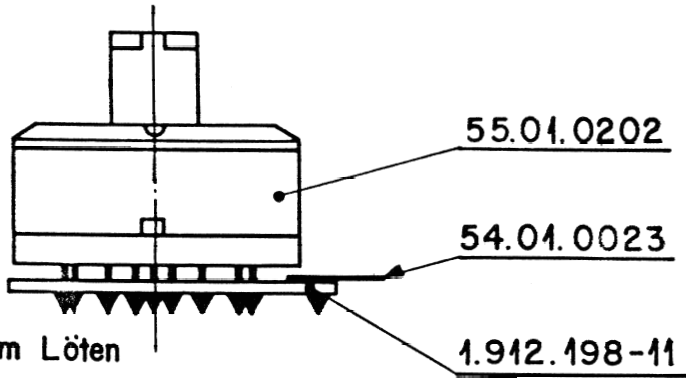

Schalter während dem Lötén
auf Print pressen

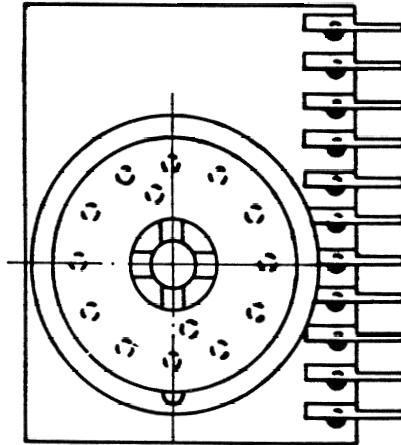

Werkstoff	Norm-Nr.:	Güte:		Änderung					③	
	DIN-Bez.:	Oberfläche								②
	Abmessung:	Beh.:								①
Zugehörige Unterlagen:	Freimasstoleranz:	Maßstab:	Ausgabe		6.5.83	A.Ho	W	ka	④	
	±	2 : 1	Datum	Gez.	Gepr.	Ges.	Index			
Ersatz für:	Ersetzt durch:		Kopie für:							
STUDER REGENSDORF ZÜRICH	Benennung: Switch-Board - B 2		Nummer: 1.912.198-00							

IND.	POS.NO.	PART NO.	VALUE	SPECIFICATIONS / EQUIVALENT			MANUF.
	A.....1	1.912.197.00		SWITCH-BOARD-B1			
	A.....2	1.912.198.00		SWITCH-BOARD-B2			
	C.....1	59.05.1681	680 pF	1%	500V	PP	
	C.....2	59.05.1681	680 pF	1%	500V	PP	
	C.....3	59.06.0102	1 nF	10%	50V	PE	
	C.....4	59.22.6220	22 uF	-20%	25V	EL	
	C.....5	59.34.2220	22 pF	5%		CE	
	C.....6	59.06.0223	22 nF	10%	50V	PE	
	C.....7	59.34.2220	22 pF	5%		CE	
	C.....8	59.06.0223	22 nF	10%	50V	PE	
	C.....9	59.34.4221	220 pF	5%		CE	
	C.....10	59.22.6220	22 uF	-20%	25V	EL	
	C.....11	59.22.5470	47 uF	-20%	25V	EL	
	C.....12	59.34.4221	220 pF	5%		CE	
	C.....13	59.22.6220	22 uF	-20%	25V	EL	
	C.....14	59.22.2221	220 uF	-20%	6V	EL	
	C.....15		not used				
	C.....16	59.05.1681	680 pF	1%	500V	PP	
	C.....17	59.05.1681	680 pF	1%	500V	PP	
	C.....18	59.06.0682	6.8 nF	5%	50V	PE	
	C.....19	59.34.5391	390 pF	5%		CE	
	C.....20	59.22.4101	100 uF	-20%	16V	EL	
	C.....21	59.22.2221	220 uF	-20%	6V	EL	
	C.....22	59.22.4101	100 uF	-20%	16V	EL	
	C.....23		not used				
	C.....24		not used				
	C.....25	59.22.4101	100 uF	-20%	16V	EL	
	C.....26	59.22.4101	100 uF	-20%	16V	EL	
	C.....27	59.22.4101	100 uF	-20%	16V	EL	
	C.....28	59.06.0223	22 nF		50V	PE	
	C.....29	59.22.2221	220 uF	-20%	6V	EL	
	C.....30	59.34.2220	22 pF	5%		CE	
	C.....31	59.34.4101	100 pF	5%		CE	
	C.....32	59.22.2221	220 uF	-20%	6V	EL	
(01)	C.....33		not used				
(01)	C.....34	59.06.0682	6.8 nF	-20%	50V	PE	
S T U D E R (03) 84/10/04 TA			MONO-INPUT-UNIT-B-4CH/8CH	1.912.120.00	PAGE	1	

IND.	POS.NO.	PART NO.	VALUE	SPECIFICATIONS / EQUIVALENT			MANUF.
	C.....35	59.22.4101	100 uF	-20%	16V	EL	
	C.....36	59.06.0223	22 nF		50V	PE	
	C.....37	59.06.0223	22 nF		50V	PE	
	C.....38	59.06.5474	470 nF	5%	50V	PE	
	C.....39	59.06.5474	470 nF	5%	50V	PE	
	C.....40	59.06.5474	470 nF	5%	50V	PE	
	C.....41	59.22.4101	100 uF	-20%	16V	EL	
	C.....42	59.05.2222	2.2 nF	2.5%	50V	PP	
	C.....43	59.34.2220	22 pF	5%		CE	
	C.....44	59.22.4101	100 uF	-20%	16V	EL	
	C.....45	59.22.4101	100 uF	-20%	16V	EL	
	C.....46	59.22.6220	22 uF	-20%	25V	EL	
	C.....47	59.22.6220	22 uF	-20%	25V	EL	
	C.....48		not used				
	C.....49	59.22.6220	22 uF	-20%	25V	EL	
	C.....50	59.05.1103	10 nF	1%	50V	PP	
	C.....51	59.22.4101	100 uF	-20%	16V	EL	
	C.....52		not used				
	C.....53	59.22.4101	100 uF	-20%	16V	EL	
	C.....54	59.22.6220	22 uF	-20%	25V	EL	
	C.....55	59.05.2152	1.5 nF	2.5%	50V	PP	
	C.....56	59.12.7123	12 nF	1%	50V	PS	
	C.....57	59.06.0223	22 nF	10%	50V	PE	
	C.....58		not used				
	C.....59	59.22.4101	100 uF	-20%	16V	EL	
	C.....60	59.22.6220	22 uF	-20%	25V	EL	
	C.....61	59.34.4101	100 pF	5%		CE	
	C.....62	59.22.4101	100 uF	-20%	16V	EL	
	C.....63	59.22.4101	100 uF	-20%	16V	EL	
	C.....64	59.22.6220	22 uF	-20%	25V	EL	
	C.....65	59.05.2153	15 nF	2.5%	50V	PP	
	C.....66	59.22.4101	100 uF	-20%	16V	EL	
	C.....67	59.22.4101	100 uF	-20%	16V	EL	
	C.....68	59.06.0223	22 nF	10%	50V	PE	
(03)	C.....69	59.34.4101	100 pF	5%		CE	
	C.....70	59.06.0223	22 nF	10%	50V	PE	
	C.....71	59.34.4101	100 pF	5%		CE	
S T U D E R (03) 84/10/04 TA			MONO-INPUT-UNIT-B-4CH/8CH	1.912.120.00	PAGE	2	

IND.	POS.NO.	PART NO.	VALUE	SPECIFICATIONS / EQUIVALENT		MANUF.
C....72		59.34.2220	22 pF	5%		CE
C....73		59.22.4101	100 uF	-20%	16V	EL
C....74		59.22.4101	100 uF	-20%	16V	EL
C....75		59.34.4101	100 pF	5%		CE
C....76		59.34.2220	22 pF	5%		CE
C....77		59.22.4101	100 uF	-20%	16V	EL
C....78		59.22.4101	100 uF	-20%	16V	EL
C....79		59.34.2220	22 pF	5%		CE
C....80		59.22.4101	100 uF	-20%	16V	EL
C....81		59.22.4101	100 uF	-20%	16V	EL
C....82		59.34.2220	22 pF	5%		CE
C....83		59.22.4101	100 uF	-20%	16V	EL
C....84			not used			
C....85		59.06.0682	6.8 nF		50V	PE
C....86		59.06.0682	6.8 nF		50V	PE
C....87		59.06.0682	6.8 nF		50V	PE
C....88		59.06.0682	6.8 nF		50V	PE
C....89		59.06.0682	* 6.8 nF		50V	PE
C....90		59.06.0682	* 6.8 nF		50V	PE
C....91		59.06.0682	* 6.8 nF		50V	PE
C....92		59.06.0682	* 6.8 nF		50V	PE
C....93		59.06.0682	6.8 nF		50V	PE
C....94		59.34.4221	220 pF	5%		CE
C....95		59.06.0682	6.8 nF		50V	PE
C....96		59.34.4222	220 pF	5%		CE
C....97		59.06.0682	6.8 nF		50V	PE
C....98		59.34.4221	220 pF	5%		CE
C....99		59.06.0682	6.8 nF		50V	PE
C...100		59.34.4221	220 pF	5%		CE
C...101			not used			
C...102			not used			
C...103		59.22.4101	100 uF	-20%	16V	EL
C...104		59.34.4221	220 pF	5%		CE
C...105			680 pF	1%	500V	PP 59051681 option 1
C...106			680 pF	1%	500V	PP 59051681 option 1
C...107		59.06.0223	22 nF	10%	50V	PE
C...108		59.06.0223	22 nF	10%	50V	PE

S T U D E R (03) 84/10/04 TA MONO-INPUT-UNIT-B-4CH/8CH 1.912.120.00 PAGE 3

IND.	POS.NO.	PART NO.	VALUE	SPECIFICATIONS / EQUIVALENT		MANUF.
C...109			not used			
C...110			not used			
C...111			not used			
D.....1		50.04.0125	1N4448			any
D.....2		50.04.0125	1N4448			any
D.....3		50.04.0125	1N4448			any
D.....4		50.04.0125	1N4448			any
D.....5			not used			
D.....6		50.04.0125	1N4448			any
D.....7		50.04.0112	Z 5.1V	400mW	BZX83C 5.1, BZX55C 5.1, ZPD 5.1	any
D.....8		50.04.0125	1N4448			any
D.....9		50.04.0125	1N4448			any
D...10		50.04.0125	1N4448			any
D...11		50.04.0125	1N4448			any
D...12		50.04.0125	1N4448			any
D...13		50.04.0125	* 1N4448			any
D...14		50.04.0125	1N4448			any
D...15		50.04.0125	1N4448			any
D...16		50.04.0125	* 1N4448			any
D...17		50.04.0125	1N4448			any
D...18		50.04.0125	* 1N4448			any
D...19		50.04.0125	* 1N4448			any
D...20		50.04.0125	1N4448			any
D...21		50.04.0125	1N4448			any
D...22		50.04.0125	1N4448			any
D...23		50.04.0125	1N4448			any
D...24		50.04.0125	1N4448			any
DL....1		50.04.2111	MV5753	red		GI,HP
DL....2		50.04.2111	MV5753	red		GI,HP
IC....1		50.05.0244	NE5534NB	single op. amp.	low noise	Sig,Ra
IC....2		50.09.0106	NE5532AN	dual op. amp.	low noise	Sig,Ex,Ra
IC....3		50.09.0106	NE5532AN	dual op. amp.	low noise	Sig,Ex,Ra
IC....4		50.09.0103	TL 071	single op. amp.		TI
IC....5		50.09.0105	NE5532	dual op. amp.		Sig,Ex,Ra

S T U D E R (03) 84/10/04 TA MONO-INPUT-UNIT-B-4CH/8CH 1.912.120.00 PAGE 4

IND.	POS.NO.	PART NO.	VALUE	SPECIFICATIONS / EQUIVALENT	MANUF.
IC....6		50.05.0243	NE5534N	single op. amp.	TI,Sig,Ra
IC....7		50.07.0081	CD4081	2 input and-gate CMOS	Fc,Mot,RCA
IC....8		50.07.0049	CD4049	hex. inverter CMOS	Fc,Mot
IC....9		50.09.0107	RC4559	dual op. amp.	Ra,NEC
IC...10		50.09.0107	RC4559	dual op. amp.	Ra,NEC
IC...11		50.05.0158	NE 555	timer	Sig,Mot,NSC
IC...12		50.09.0105	NE5532	dual op. amp.	Sig,Ex,Ra
IC...13		50.05.0243	NE5534N	single op. amp.	TI,Sig,Ra
IC...14		50.05.0243	NE5534N	single op. amp.	TI,Sig,Ra
IC...15		50.05.0243	NE5534N	single op. amp.	TI,Sig,Ra
IC...16		50.05.0243	NE5534N	single op. amp.	TI,Sig,Ra
IC...17		50.05.0243	NE5534N	single op. amp.	TI,Sig,Ra
L.....1	1.022.207.00			hf-sym.choke	St
P.....3	54.11.2007		2*8 pin	euroconnector	Bu
P.....4	54.01.0359		2*16pin	euroconnector	Bu
P.....6	54.01.0359		2*16pin	euroconnector	Bu
Q.....1	50.03.0350		J 112	N-JFET	NS,Mot,Six
Q.....2	50.03.0350		J 112	N-JFET	NS,Mot,Six
Q.....3	50.03.0350		J 112	N-JFET	NS,Mot,Six
Q.....4	50.03.0350		J 112	N-JFET	NS,Mot,Six
Q.....5	50.03.0350		J 112	N-JFET	NS,Mot,Six
Q.....6	50.03.0350		J 112	N-JFET	NS,Mot,Six
Q.....7	50.03.0350		J 112	N-JFET	NS,Mot,Six
Q.....8	50.03.0436		BC 237	NPN IC>100mA, B>100	any
Q.....9	50.03.0350		J 112	N-JFET	NS,Mot,Six
Q....10	50.03.0350		J 112	N-JFET	NS,Mot,Six
Q....11	50.03.0350		J 112	N-JFET	NS,Mot,Six
Q....12	50.03.0350		J 112	N-JFET	NS,Mot,Six
Q....13	50.03.0350		J 112	N-JFET	NS,Mot,Six
Q....14	50.03.0350		J 112	N-JFET	NS,Mot,Six
Q....15	50.03.0350		J 112	N-JFET	NS,Mot,Six
Q....16	50.03.0350		J 112	N-JFET	NS,Mot,Six
Q....17	50.03.0350	*	J 112	N-JFET	NS,Mot,Six
Q....18	50.03.0350	*	J 112	N-JFET	NS,Mot,Six

S T U D E R (03) 84/10/04 TA MONO-INPUT-UNIT-B-4CH/8CH 1.912.120.00 PAGE 5

IND.	POS.NO.	PART NO.	VALUE	SPECIFICATIONS / EQUIVALENT	MANUF.
Q....19		50.03.0350	* J 112	N-JFET	NS,Mot,Six
Q....20		50.03.0350	* J 112	N-JFET	NS,Mot,Six
Q....21		50.03.0350	* J 112	N-JFET	NS,Mot,Six
Q....22		50.03.0350	* J 112	N-JFET	NS,Mot,Six
Q....23		50.03.0350	* J 112	N-JFET	NS,Mot,Six
Q....24		50.03.0350	* J 112	N-JFET	NS,Mot,Six
Q....25		50.03.0350	J 112	N-JFET	NS,Mot,Six
Q....26		50.03.0350	J 112	N-JFET	NS,Mot,Six
Q....27		50.03.0350	J 112	N-JFET	NS,Mot,Six
Q....28		50.03.0350	J 112	N-JFET	NS,Mot,Six
Q....29		50.03.0350	J 112	N-JFET	NS,Mot,Six
Q....30		50.03.0350	J 112	N-JFET	NS,Mot,Six
R.....1		57.11.3103	10 kOhm	1% 0.25W MF	
R.....2		57.11.3103	10 kOhm	1% 0.25W MF	
R.....3		57.11.3432	4.3 kOhm	1% 0.25W MF	
R.....4		57.11.3432	4.3 kOhm	1% 0.25W MF	
R.....5		57.11.4152	1.5 kOhm	5% 0.25W MF	
R.....6		57.11.4223	22 kOhm	5% 0.25W MF	
R.....7		57.11.4330	33 Ohm	5% 0.25W MF	
R.....8		57.11.4104	100 kOhm	5% 0.25W MF	
R.....9		57.11.4223	22 kOhm	5% 0.25W MF	
R.....10		57.11.3152	1.5 kOhm	1% 0.25W MF	
R.....11		57.11.3162	1.6 kOhm	1% 0.25W MF	
R.....12		57.11.3123	12 kOhm	1% 0.25W MF	
R.....13		57.11.3561	560 Ohm	1% 0.25W MF	
R.....14		57.11.3362	3.6 kOhm	1% 0.25W MF	
R.....15		57.11.3153	15 kOhm	1% 0.25W MF	
R.....16			not used		
R.....17		57.11.3331	330 Ohm	1% 0.25W MF	
R.....18		57.11.3470	47 Ohm	1% 0.25W MF	
R.....19		57.11.4104	100 kOhm	5% 0.25W MF	
R.....20		57.11.4472	4.7 kOhm	5% 0.25W MF	
R.....21		57.11.4471	470 Ohm	5% 0.25W MF	
R.....22		57.11.4101	100 Ohm	5% 0.25W MF	
R.....23		1.010.002.58	10 kOhm	20% pos. log.	variable resistor St
R.....24		57.11.4332	3.3 kOhm	5% 0.25W CF	

S T U D E R (03) 84/10/04 TA MONO-INPUT-UNIT-B-4CH/8CH 1.912.120.00 PAGE 6

IND.	POS.NO.	PART NO.	VALUE	SPECIFICATIONS / EQUIVALENT			MANUF.
R....25		57.11.4332	3.3 kOhm	5%	0.25W	CF	
R....26		57.11.4330	33 Ohm	5%	0.25W	CF	
R....27		57.11.3152	1.5 kOhm	1%	0.25W	MF	
R....28		57.11.3152	1.5 kOhm	1%	0.25W	MF	
R....29		57.11.3392	3.9 kOhm	1%	0.25W	MF	
R....30		57.11.3392	3.9 kOhm	1%	0.25W	MF	
R....31		57.11.3392	3.9 kOhm	5%	0.25W	MF	
R....32		57.11.4101	100 Ohm	5%	0.25W	MF	
R....33		57.11.3472	4.7 kOhm	1%	0.25W	MF	
R....34		57.11.3432	4.3 kOhm	1%	0.25W	MF	
R....35		58.01.8502	5 kOhm	10%			
R....36		57.11.4182	1.8 kOhm	5%	0.25W	MF	
R....37		57.11.4472	4.7 kOhm	5%	0.25W	MF	
R....38		57.11.3132	1.3 kOhm	5%	0.25W	MF	
R....39	1.010.001.58		10 kOhm	20%	lin.	variable resistor	St
R....40		57.11.4472	4.7 kOhm	5%	0.25W	MF	
R....41		57.11.3132	1.3 kOhm	5%	0.25W	MF	
R....42		57.11.4333	33 kOhm	5%	0.25W	MF	
R....43		57.11.3472	4.7 kOhm	1%	0.25W	CF	
R....44		57.11.3472	4.7 kOhm	1%	0.25W	CF	
R....45		57.11.3473	47 kOhm	1%	0.25W	CF	
R....46		57.11.3473	47 kOhm	1%	0.25W	CF	
R....47		57.11.4333	33 kOhm	5%	0.25W	CF	
R....48		57.99.0209	5.6 Ohm			PTC	Philips Nr.2322 662 91005
R....49		57.99.0209	5.6 Ohm			PTC	Philips Nr.2322 662 91005
R....50		57.99.0209	5.6 Ohm			PTC	Philips Nr.2322 662 91005
R....51		57.99.0206	50 Ohm			PTC	Philips Nr.2322 660 91008
R....52		57.11.4682	6.8 kOhm	5%	0.25W	CF	
R....53		57.11.4104	100 kOhm	5%	0.25W	CF	
R....54		57.11.4104	100 kOhm	5%	0.25W	CF	
R....55		57.11.4104	100 kOhm	5%	0.25W	CF	
R....56		57.11.6106	10 MOhm	10%	0.25W	CF	
R....57		57.11.4682	6.8 kOhm	5%	0.25W	CF	
R....58		57.11.4332	3.3 kOhm	5%	0.25W	CF	
R....59		57.11.4332	3.3 kOhm	5%	0.25W	CF	
R....60		57.11.4682	6.8 kOhm	5%	0.25W	CF	
R....61		57.11.6106	10 MOhm	10%	0.25W	CF	

S T U D E R (03) 84/10/04 TA MONO-INPUT-UNIT-B-4CH/8CH 1.912.120.00 PAGE 7

IND.	POS.NO.	PART NO.	VALUE	SPECIFICATIONS / EQUIVALENT			MANUF.
R....62		57.11.4105	1 MOhm	5%	0.25W	CF	
R....63		57.11.4333	33 kOhm	5%	0.25W	CF	
R....64		57.11.4682	6.8 kOhm	5%	0.25W	CF	
R....65		57.11.4335	3.3 MOhm	5%	0.25W	CF	
R....66		57.11.4104	100 kOhm	5%	0.25W	CF	
R....67		57.11.4104	100 kOhm	5%	0.25W	CF	
R....68		57.11.4104	100 kOhm	5%	0.25W	CF	
R....69		57.11.4103	10 kOhm	5%	0.25W	CF	
R....70		57.11.3202	2 kOhm	1%	0.25	CF	
R....71		57.11.4335	3.3 MOhm	5%	0.25W	CF	
R....72		57.11.4104	100 kOhm	5%	0.25W	CF	
R....73		57.11.4104	100 kOhm	5%	0.25W	CF	
R....74		57.11.4104	100 kOhm	5%	0.25W	CF	
R....75		57.11.4103	10 kOhm	5%	0.25W	CF	
R....76		57.11.4104	100 kOhm	5%	0.25W	CF	
R....77		57.11.4223	22 kOhm	5%	0.25W	CF	
R....78		57.11.4332	3.3 kOhm	5%	0.25W	CF	
R....79		57.11.4104	100 kOhm	5%	0.25W	CF	
R....80		57.11.4104	100 kOhm	5%	0.25W	CF	
R....81		57.11.4224	220 kOhm	5%	0.25W	CF	
R....82		57.11.4332	3.3 kOhm	5%	0.25W	CF	
R....83		57.11.4104	100 kOhm	5%	0.25W	CF	
R....84		57.11.3102	1 kOhm	1%	0.25W	CF	
R....85		57.11.3473	47 kOhm	1%	0.25W	CF	
R....86		57.11.3822	8.2 kOhm	1%	0.25W	CF	
R....87		57.11.4104	100 kOhm	5%	0.25W	CF	
R....88		57.11.4330	33 Ohm	5%	0.25W	CF	
R....89		57.11.4223	22 kOhm	5%	0.25W	CF	
R....90		57.11.4104	100 kOhm	5%	0.25W	CF	
R....91		57.11.4104	100 kOhm	5%	0.25W	CF	
R....92		57.11.4331	330 Ohm	5%	0.25W	CF	
R....93		57.11.4102	1 kOhm	5%	0.25W	CF	
R....94		57.11.6106	10 MOhm	10%	0.25W	CF	
R....95		57.11.4104	100 kOhm	5%	0.25W	CF	
R....96		57.11.4333	33 kOhm	5%	0.25W	CF	
R....97		57.11.4121	120 Ohm	5%	0.25W	CF	
R....98	1.010.003.58		4.7 kOhm	20%	lin.	variable resistor	St

S T U D E R (03) 84/10/04 TA MONO-INPUT-UNIT-B-4CH/8CH 1.912.120.00 PAGE 8

IND.	POS.NO.	PART NO.	VALUE	SPECIFICATIONS / EQUIVALENT	MANUF.
R....99		57.11.4121	120 Ohm	5% 0.25W CF	
R...100		57.11.4103	10 kOhm	5% 0.25W CF	
R...101		57.11.4103	10 kOhm	5% 0.25W CF	
R...102		57.11.3682	6.8 kOhm	1% 0.25W CF	
R...103		57.11.3562	5.6 kOhm	1% 0.25W CF	
R...104		57.11.4104	100 kOhm	5% 0.25W CF	
R...105		57.11.4684	680 kOhm	5% 0.25W CF	
R...106		57.11.3392	3.9 kOhm	1% 0.25W CF	
R...107			100 kOhm	10% neg.log.variable resistor, see R98	St
R...108		57.11.4561	560 Ohm	5% 0.25W CF	
R...109		1.010.005.58	4.7 kOhm	20% lin. variable resistor	St
R...110		57.11.4561	560 Ohm	5% 0.25W CF	
R...111		57.11.4103	10 kOhm	5% 0.25W CF	
R...112		57.11.4103	10 kOhm	5% 0.25W CF	
R...113		57.11.4105	1 MOhm	5% 0.25W CF	
R...114		57.11.4105	1 MOhm	5% 0.25W CF	
R...115		57.11.3472	4.7 kOhm	1% 0.25W CF	
R...116			100 kOhm	10% neg.log.variable resistor, see R109	St
R...117			100 kOhm	10% neg.log.variable resistor, see R109	St
R...118		57.11.3512	5.1 kOhm	1% 0.25W CF	
R...119		57.11.4103	10 kOhm	5% 0.25W CF	
R...120		57.11.4335	3.3 MOhm	5% 0.25W CF	
R...121		57.11.4103	10 kOhm	5% 0.25W CF	
R...122		57.11.4331	330 Ohm	5% 0.25W CF	
R...123		57.11.4103	10 kOhm	5% 0.25W CF	
R...124		57.11.4103	10 kOhm	5% 0.25W CF	
R...125		57.11.4121	120 Ohm	5% 0.25W CF	
R...126		1.010.003.58	4.7 kOhm	20% lin. variable resistor	St
R...127		57.11.4121	120 Ohm	5% 0.25W CF	
R...128		57.11.3682	6.8 kOhm	1% 0.25W CF	
R...129		57.11.3562	5.6 kOhm	1% 0.25W CF	
R...130		57.11.4104	100 kOhm	5% 0.25W CF	
R...131		57.11.4103	10 kOhm	5% 0.25W CF	
R...132		57.11.4684	680 kOhm	5% 0.25W CF	
R...133		57.11.4103	10 kOhm	5% 0.25W CF	
R...134		57.11.3472	4.7 kOhm	1% 0.25W CF	
R...135		57.11.4223	22 kOhm	5% 0.25W CF	

S T U D E R (03) 84/10/04 TA MONO-INPUT-UNIT-B-4CH/8CH 1.912.120.00 PAGE 9

IND.	POS.NO.	PART NO.	VALUE	SPECIFICATIONS / EQUIVALENT	MANUF.
R...136			100 kOhm	10% neg.log.variable resistor, see R126	St
R...137		57.11.4223	22 kOhm	5% 0.25W CF	
R...138		57.11.4182	1.8 kOhm	5% 0.25W CF	
R...139		57.11.4330	33 Ohm	5% 0.25W CF	
R...140		57.11.3103	10 kOhm	1% 0.25W CF	
R...141		57.11.4102	1 kOhm	5% 0.25W CF	
R...142		57.11.4471	470 Ohm	5% 0.25W CF	
R...143		57.11.4332	3.3 kOhm	5% 0.25W CF	
R...144		57.11.4332	3.3 kOhm	5% 0.25W CF	
R...145		57.11.4332	3.3 kOhm	5% 0.25W CF	
R...146		1.010.004.58	10 kOhm	10% pos.log.variable resistor	St
R...147			10 kOhm	10% neg.log.variable resistor, see R146	St
R...148		57.11.4332	3.3 kOhm	5% 0.25W CF	
R...149		57.11.4332	3.3 kOhm	5% 0.25W CF	
R...150		57.11.4332	3.3 kOhm	5% 0.25W CF	
R...151		57.11.4333	33 kOhm	5% 0.25W CF	
R...152		57.11.4333	33 kOhm	5% 0.25W CF	
R...153		57.11.4332	3.3 kOhm	5% 0.25W CF	
R...154		57.11.4332	3.3 kOhm	5% 0.25W CF	
R...155		57.11.4333	33 kOhm	5% 0.25W CF	
R...156		57.11.4332	3.3 kOhm	5% 0.25W CF	
R...157		57.11.4332	3.3 kOhm	5% 0.25W CF	
R...158		57.11.4471	470 Ohm	5% 0.25W CF	
R...159		57.11.4333	33 kOhm	5% 0.25W CF	
R...160		1.369.150.03	10 kOhm	20% pos.log.variable resistor	St
R...161		57.11.4332	3.3 kOhm	5% 0.25W CF	
R...162		1.369.150.03	10 kOhm	20% pos.log.variable resistor	St
R...163		57.11.4332	3.3 kOhm	5% 0.25W CF	
R...164		1.369.150.03	10 kOhm	20% pos.log.variable resistor	St
R...165		57.11.4332	3.3 kOhm	5% 0.25W CF	
R...166		1.010.006.58	4.7 kOhm	20% lin. variable resistor	St
R...167			10 kOhm	20% neg.log.variable resistor, see R166	St
R...168		57.11.4332	3.3 kOhm	5% 0.25W CF	
R...169			10 kOhm	20% pos.log.variable resistor, see R166	St
R...170		57.11.4332	3.3 kOhm	5% 0.25W CF	
R...171		57.11.4332	3.3 kOhm	5% 0.25W CF	
R...172		57.11.4104	100 kOhm	5% 0.25W CF	

S T U D E R (03) 84/10/04 TA MONO-INPUT-UNIT-B-4CH/8CH 1.912.120.00 PAGE 10

IND.	POS.NO.	PART NO.	VALUE	SPECIFICATIONS / EQUIVALENT	MANUF.
R...	173	57.11.4104	100 kOhm	5% 0.25W CF	
R...	174	57.11.4104	100 kOhm	5% 0.25W CF	
R...	175	57.11.4104	100 kOhm	5% 0.25W CF	
R...	176	57.11.4332	3.3 kOhm	5% 0.25W CF	
R...	177	57.11.4104	100 kOhm	5% 0.25W CF	
R...	178	57.11.4104	100 kOhm	5% 0.25W CF	
R...	179	57.11.4104	100 kOhm	5% 0.25W CF	
R...	180	57.11.4104	100 kOhm	5% 0.25W CF	
R...	181	57.11.4332	3.3 kOhm	5% 0.25W CF	
R...	182	57.11.4104	100 kOhm	5% 0.25W CF	
R...	183	57.11.4104	100 kOhm	5% 0.25W CF	
R...	184	57.11.4104	100 kOhm	5% 0.25W CF	
R...	185	57.11.4104	100 kOhm	5% 0.25W CF	
R...	186	57.11.4332	3.3 kOhm	5% 0.25W CF	
R...	187	57.11.4104	100 kOhm	5% 0.25W CF	
R...	188	57.11.4104	100 kOhm	5% 0.25W CF	
R...	189	57.11.4104	100 kOhm	5% 0.25W CF	
R...	190	57.11.4104	100 kOhm	5% 0.25W CF	
R...	191	57.11.4332	*3.3 kOhm	5% 0.25W CF	
R...	192	57.11.4104	*100 kOhm	5% 0.25W CF	
R...	193	57.11.4104	*100 kOhm	5% 0.25W CF	
R...	194	57.11.4104	*100 kOhm	5% 0.25W CF	
R...	195	57.11.4104	*100 kOhm	5% 0.25W CF	
R...	196	57.11.4332	*3.3 kOhm	5% 0.25W CF	
R...	197	57.11.4104	*100 kOhm	5% 0.25W CF	
R...	198	57.11.4104	*100 kOhm	5% 0.25W CF	
R...	199	57.11.4104	*100 kOhm	5% 0.25W CF	
R...	200	57.11.4104	*100 kOhm	5% 0.25W CF	
R...	201	57.11.4332	*3.3 kOhm	5% 0.25W CF	
R...	202	57.11.4104	*100 kOhm	5% 0.25W CF	
R...	203	57.11.4104	*100 kOhm	5% 0.25W CF	
R...	204	57.11.4104	*100 kOhm	5% 0.25W CF	
R...	205	57.11.4104	*100 kOhm	5% 0.25W CF	
R...	206	57.11.4332	*3.3 kOhm	5% 0.25W CF	
R...	207	57.11.4104	*100 kOhm	5% 0.25W CF	
R...	208	57.11.4104	*100 kOhm	5% 0.25W CF	
R...	209	57.11.4104	*100 kOhm	5% 0.25W CF	

S T U D E R (03) 84/10/04 TA MONO-INPUT-UNIT-B-4CH/8CH 1.912.120.00 PAGE 11

IND.	POS.NO.	PART NO.	VALUE	SPECIFICATIONS / EQUIVALENT	MANUF.
R...	210	57.11.4104	*100 kOhm	5% 0.25W CF	
R...	211	57.11.4103	10 kOhm	5% 0.25W CF	
R...	212	57.11.4104	100 kOhm	5% 0.25W CF	
R...	213	57.11.4104	100 kOhm	5% 0.25W CF	
R...	214	57.11.4103	10 kOhm	5% 0.25W CF	
R...	215	57.11.4104	100 kOhm	5% 0.25W CF	
R...	216	57.11.4104	100 kOhm	5% 0.25W CF	
R...	217	57.11.4104	100 kOhm	5% 0.25W CF	
R...	218	57.11.4103	10 kOhm	5% 0.25W CF	
R...	219	57.11.4104	100 kOhm	5% 0.25W CF	
R...	220	57.11.4104	100 kOhm	5% 0.25W CF	
R...	221	57.11.4103	10 kOhm	5% 0.25W CF	
R...	222	57.11.4104	100 kOhm	5% 0.25W CF	
R...	223	57.11.4104	100 kOhm	5% 0.25W CF	
R...	224	57.11.4104	100 kOhm	5% 0.25W CF	
R...	225	57.11.4223	22 kOhm	5% 0.25W CF	
R...	226		1.5 kOhm	1% 0.25W MF 57113152	option 1
R...	227		3.9 kOhm	1% 0.25W MF 57113392	option 1
R...	228		3.9 kOhm	1% 0.25W MF 57113392	option 1
R...	229		1.5 kOhm	1% 0.25W MF 57113152	option 1
S.....	3	55.15.0002	2*U	button: 55030304	yellow
S.....	4	1.912.120.03	2*U		
S.....	5		2*U	see S4	
S.....	6		2*U	see S4	
S.....	7	55.15.0002	2*U	button: 55030305	green
S.....	8	55.15.0003	2*U	button: 55030310	white
S.....	9	55.15.0012	2*U	button: 55150106	red ITT
S.....	10	55.15.0003	2*U	button: 55030303	red ITT
S.....	11	55.15.0003	2*U	button: 55030303	red ITT
S.....	13	1.369.150.03	1*U	combined with variable resistor R 160	St
S.....	14	1.369.150.03	1*U	combined with variable resistor R 162	St
S.....	15	1.369.150.03	1*U	combined with variable resistor R 164	St
S.....	16	1.010.006.59	1*U	combined with variable resistor R 166	St
02)	S.....	55.15.0002	* 2*U	button: 55030303	red ITT
02)	S.....	55.15.0002	* 2*U	button: 55030303	red ITT
	S.....	55.15.0002	2*U	button: 55030303	red ITT

T U D E R (03) 84/10/04 TA MONO-INPUT-UNIT-B-4CH/8CH 1.912.120.00 PAGE 12

IND.	POS.NO.	PART NO.	VALUE	SPECIFICATIONS / EQUIVALENT	MANUF.
	S....20	55.15.0002	2*U	button: 55030303	red ITT
(02)	S....21	55.15.0002	2*U	button: 55030303	red ITT
(02)	S....22	55.15.0002	2*U	button: 55030303	red ITT
	S....23	55.15.0002	* 2*U	button: 55030303	red ITT
	S....24	55.15.0002	* 2*U	button: 55030303	red ITT
	T.....1	1.022.417.00		input trafo 1:3.14	St
	T.....2	1.022.451.00		input trafo 1:0.62	St
	w.....1	1.128.072.01	9-wire	flatcable	
	w.....2	1.128.072.01	9-wire	flatcable	
	w.....3		**		
	w.....4		**		
	w.....5		**		
	w.....6		**		
	XDL...1	1.010.012.50		LED-holder	St
	XDL...2	1.010.012.50		LED-holder	St

S T U D E R (03) 84/10/04 TA MONO-INPUT-UNIT-B-4CH/8CH 1.912.120.00 PAGE 13

IND.	POS.NO.	PART NO.	VALUE	SPECIFICATIONS / EQUIVALENT	MANUF.
------	---------	----------	-------	-----------------------------	--------

```

=====
* ONLY 8-CHANNEL 1.912.122.00
=====
** ONLY 4-CHANNEL
=====

```

01 83/12/16 elimination of phase-switching noise

02 84/02/08 S17 S18 only 8CH 1.912.122.00

03 84/10/04 suppression of high frequency

option 1: tape-input replaces gen-input

CE=Ceramic, CF=Carbon Film, EL=Electrolytic, MF=Metal Film,
PE=Polyester, PP=Polypropylen, PS=Polystyrol

MANUFACTURER: Bu=Burndy, Ex=Exar, Fc=Fairchild, GI=General Instrument
HP=Hewlett Packard, ITT=Intermetall, Mot=Motorola,
NS=National Semiconductors, Ph=Philips, Ra=Raytheon,
Sig=Signetics, Six=Siliconix, St=Studer,
TI=Texas Instrument

ORIG 83/01/20 (01) 83/12/16 (02) 84/02/08 (03) 84/10/04

S T U D E R (03) 84/10/04 TA MONO-INPUT-UNIT-B-4CH/8CH 1.912.120.00 PAGE 14

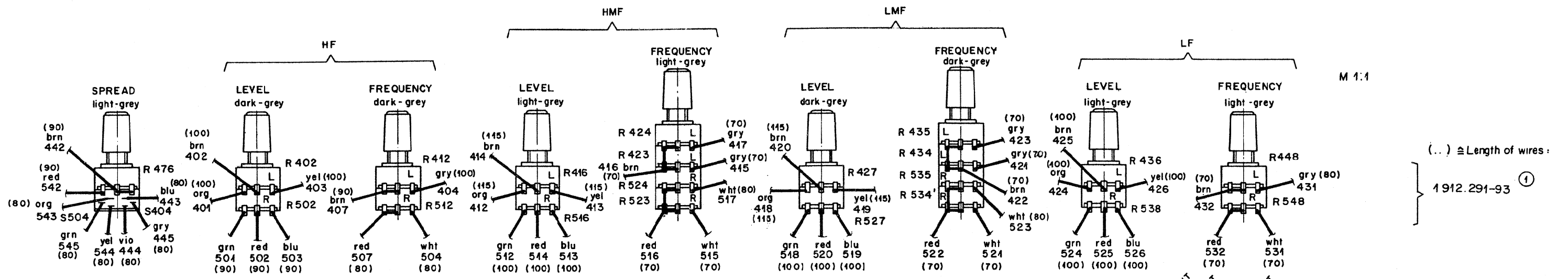

M 1:1

(...) ≙ Length of wires:
1.912.291-93 ①
1.912.291-94 ①

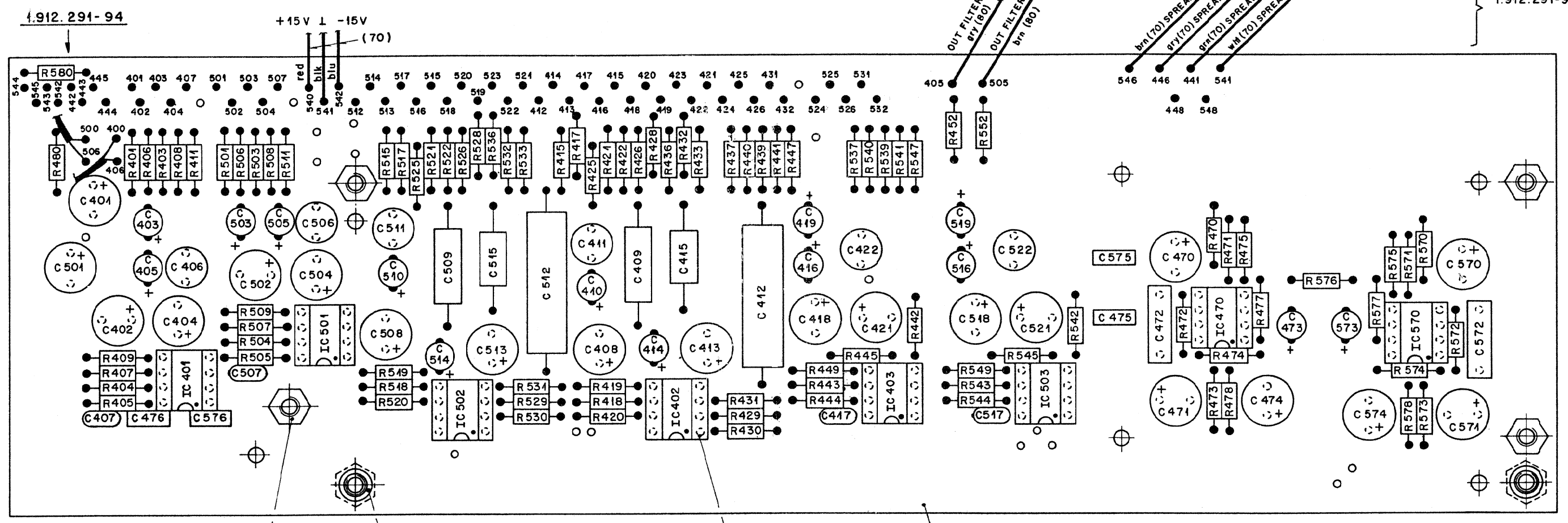

- 21.01.0354 (4x)
- 24.16.4030 (4x)
- 1.010.041-27 (4x)
- 1.010.040-22 (2x) ②
- 53.03.0166 (8x)
- 1.912.291-12

Werkstoff	Norm-Nr.:	Güte:	Anderung:	③
	DIN-Bez.:			12.9.85 A.Ho. <i>mls</i> <i>mls</i> ②
Zugehörige Unterlagen:	Abmessung:	Freimasstoleranz:	Maßstab:	22.5.84 STJ <i>1/2</i> <i>1/2</i> ①
	PL			1:1; 2:1
Ersatz für:	Ersetzt durch:	Ausgabe:		Datum Gez. Gepr. Ges. Index
STUDER REGENSDORF ZÜRICH		Benennung:		1.912.291-00
		Equalizer Board		Nummer:

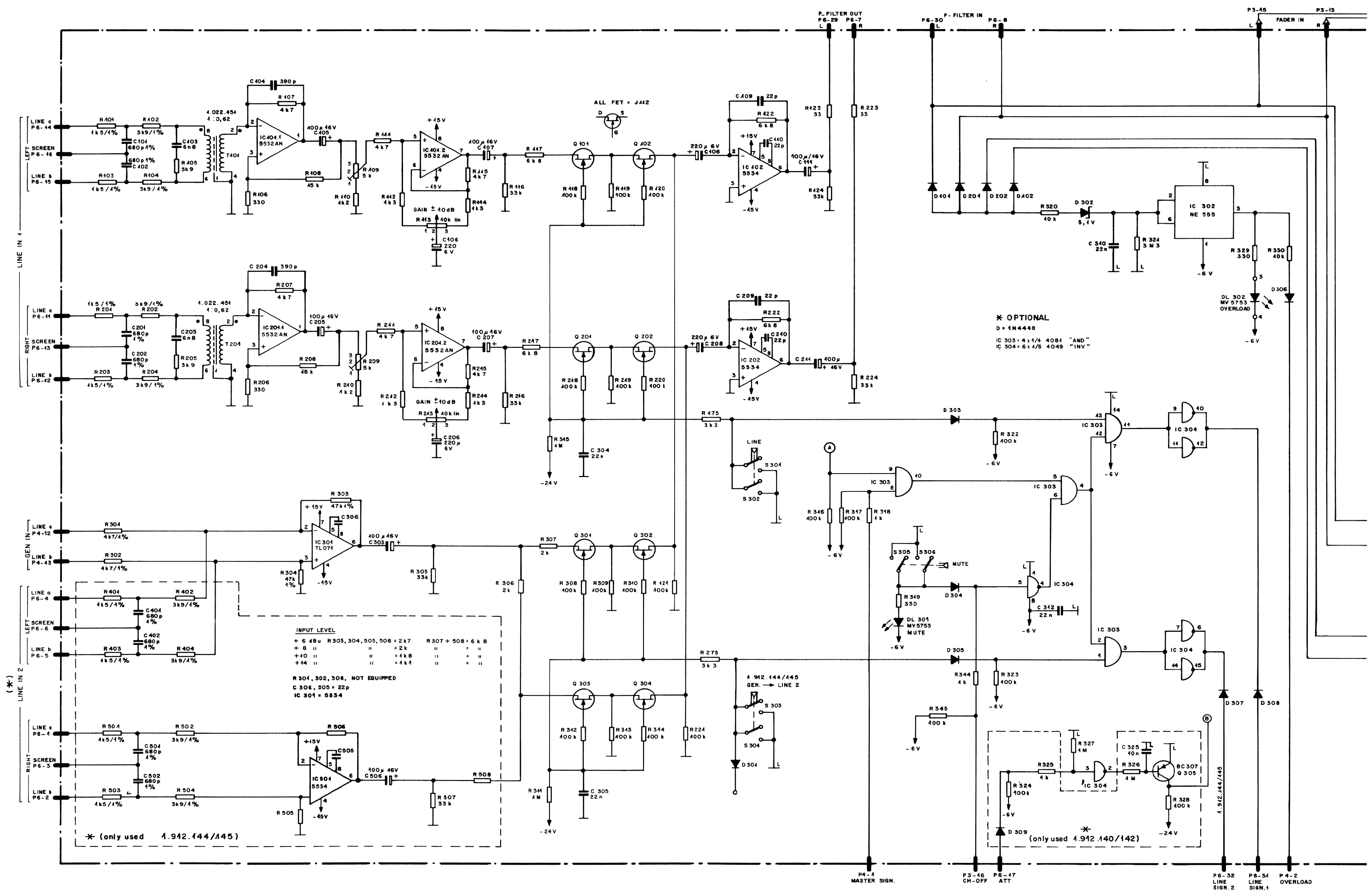

INPUT LEVEL

+6 dB	R303, 304, 505, 506 = 2k7	R307 + 508 = 6k8
+8 "	" " " " = 2k	" " " " = "
+10 "	" " " " = 4k8	" " " " = "
+14 "	" " " " = 4k4	" " " " = "

R304, 302, 306, NOT EQUIPPED
 C306, 505 = 22p
 IC301 = 5534

*** OPTIONAL**
 D = 1N4448
 IC303 = 4:1/4 4081 "AND"
 IC304 = 6:1/6 4049 "INV"

* (only used 1.912.144/145)

* (only used 1.912.140/142)

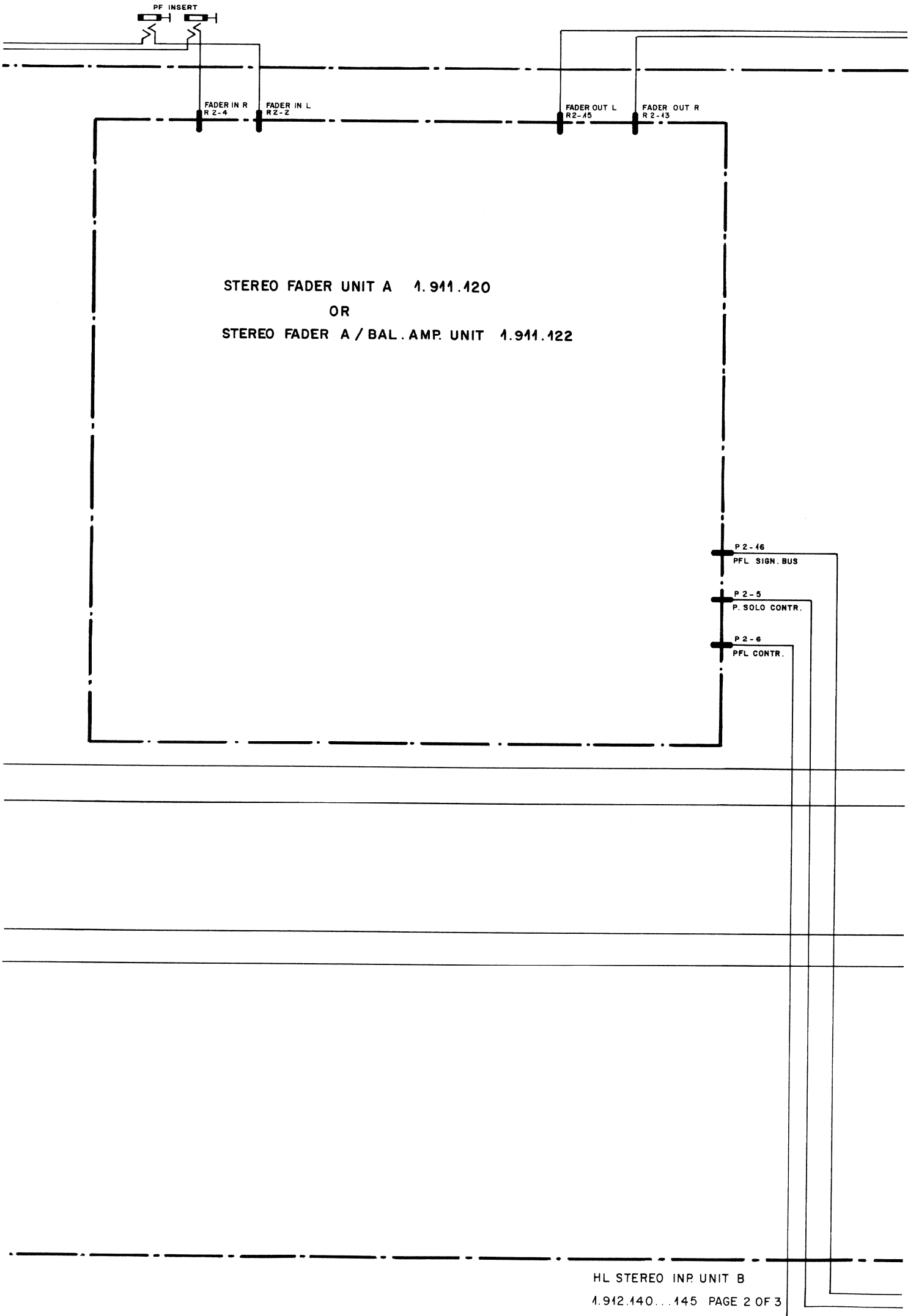

STEREO FADER UNIT A 1.911.120
 OR
 STEREO FADER A / BAL. AMP. UNIT 1.911.122

P 2-16
PFL SIGN. BUS

P 2-5
P. SOLO CONTR.

P 2-6
PFL CONTR.

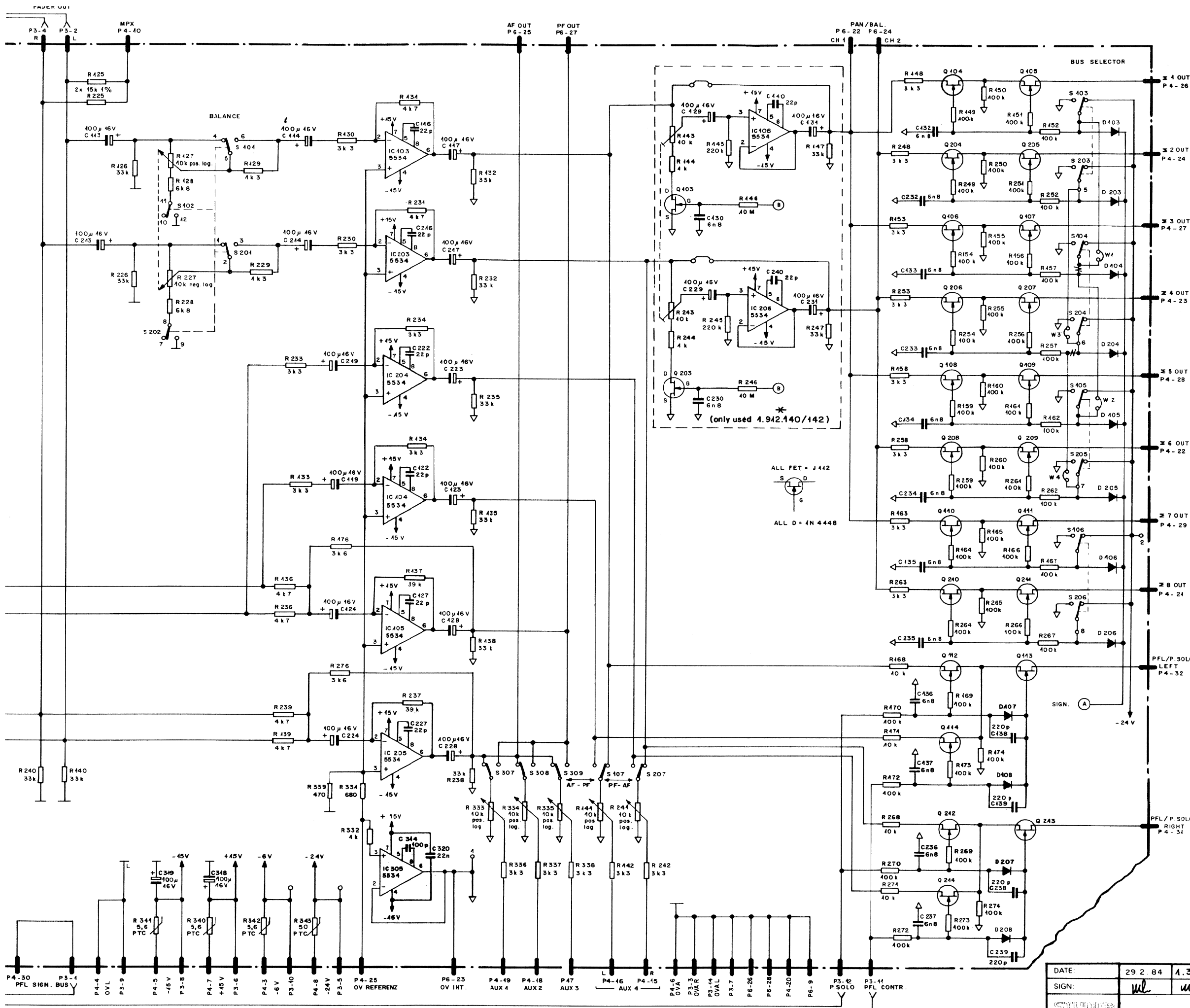

- P 6**
- 1 LINE a
 - 2 LINE b
 - 3 SCREEN
 - 4 LINE a
 - 5 LINE b
 - 6 SCREEN
 - 7 P-FILTER OUT
 - 8 P-FILTER IN
 - 9 OVA
 - 10 X
 - 11 LINE a
 - 12 LINE b
 - 13 SCREEN
 - 14 LINE a
 - 15 LINE b
 - 16 SCREEN
 - 17 ATT (*)
 - 18 X
 - 19 X
 - 20 X
 - 21 X
 - 22 CH 1 PAN/BAL
 - 23 OV INT.
 - 24 CH 2 PAN/BAL
 - 25 AF OUT
 - 26 OVA
 - 27 PF-OUT
 - 28 OVA
 - 29 P-FILTER OUT
 - 30 P-FILTER IN
 - 31 LINE SIGN. 1
 - 32 LINE SIGN. 2 (*)
- P 4**
- 1 MASTER SIGN.
 - 2 OVERLOAD
 - 3 -6V
 - 4 OVL
 - 5 -15V
 - 6 OVA
 - 7 +15V
 - 8 -24V
 - 9 X
 - 10 MPX
 - 11 X
 - 12 GEN. a
 - 13 GEN. b
 - 14 X
 - 15 AUX 4-R OUT
 - 16 AUX 4-L OUT
 - 17 AUX 3 OUT
 - 18 AUX 2 OUT
 - 19 AUX 1 OUT
 - 20 OVA
 - 21 8 OUT
 - 22 6 OUT
 - 23 4 OUT
 - 24 2 OUT
 - 25 OV REF
 - 26 1 OUT
 - 27 3 OUT
 - 28 5 OUT
 - 29 7 OUT
 - 30 PFL-SIGN. BUS
 - 31 PFL/P-SOLO R
 - 32 PFL/P-SOLO L

- P 3**
- 1 PFL-SIGN BUS
 - 2 FADER OUT L
 - 3 OVA R
 - 4 FADER OUT R
 - 5 -24V
 - 6 +15V
 - 7 OVA
 - 8 -15V
 - 9 OVL
 - 10 -6V
 - 11 PFL CONTR.
 - 12 P-SOLO CONTR
 - 13 FADER IN R
 - 14 OVA L
 - 15 FADER IN L
 - 16 CH-OFF
- * OPTIONAL**
 ONLY 4CH: W1, W2, W3, W4
 /V CIRCUIT INTERRUPT SOLDER SIDE

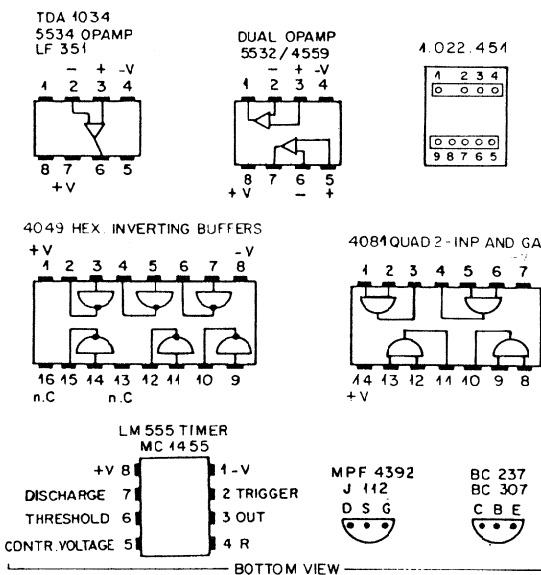

4 CH : 1.942.140/441/444
 8 CH : 1.942.142/443/445

DATE:	29.2.84	1.3.84	4.10.84		PAGE 3 OF 3
SIGN:	<i>ul</i>	<i>ul</i>	<i>ul</i>		
HL STEREO INPUT UNIT B					SC 1.942.140...145

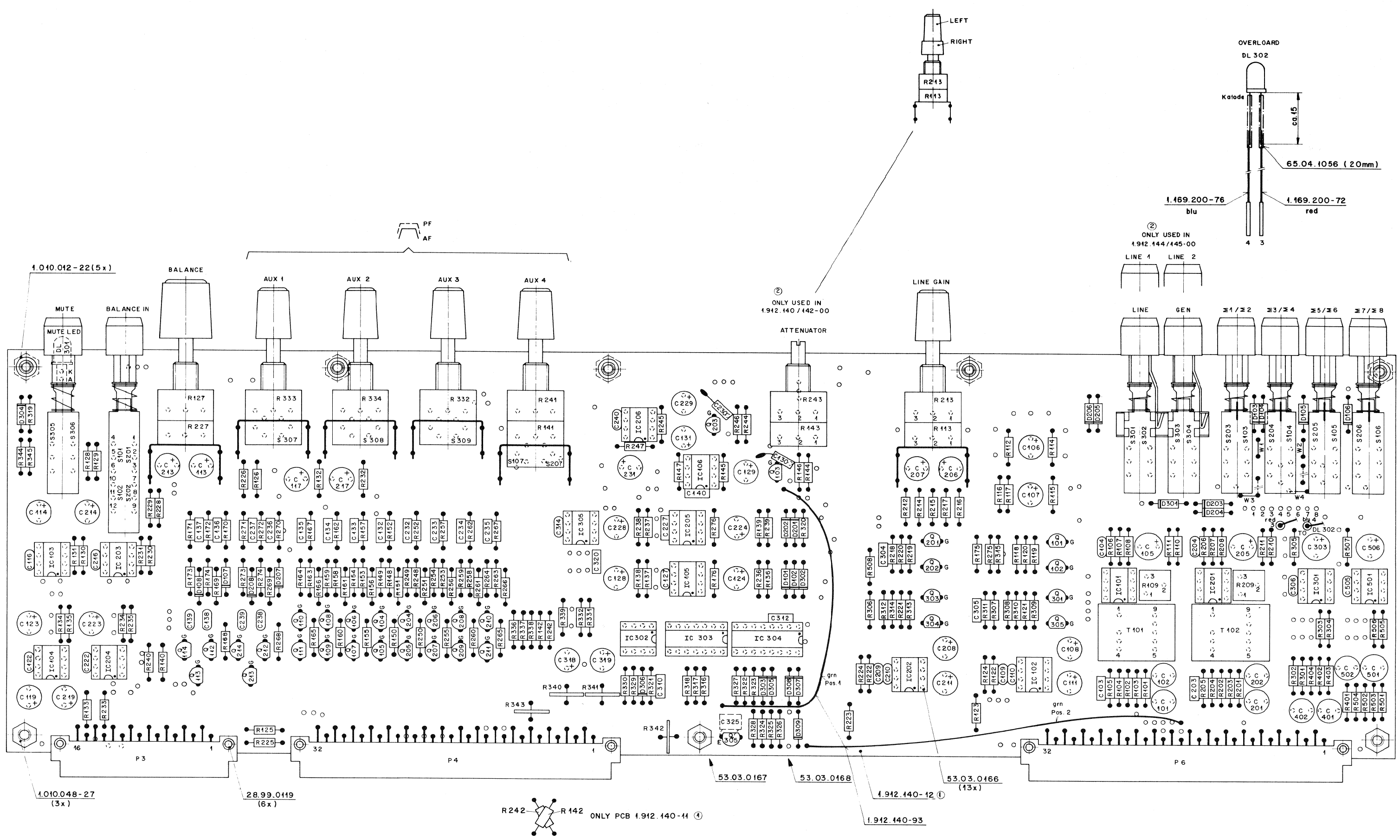

ONLY 4 CH: W1, W2, W3, W4
 // CIRCUIT INTERRUPT
 SOLDER SIDE

*

VALID FOR	NR. UNIT	NR. PL	NR. LL
4 CH RAI	1.942.140-00	1.942.140-00	1.942.140-93
4 CH LINE / GEN	1.942.144-00	1.942.144-00	-
8 CH RAI	1.942.142-00	1.942.140-00	1.942.140-93
8 CH LINE / GEN	1.942.143-00	1.942.144-00	-
4 CH 2 LINE	1.942.144-00	1.942.144-00	-
8 CH 2 LINE	1.942.145-00	1.942.144-00	-

Norm-Nr.:	Güte:	Änderung:
DIN-Bez.:	Beh.:	1.3.84 A.Ho
Abmessung:	Freinastoleranz:	7.12.83 A.Ho
Zugehörige Unterlagen:	Maßstab:	15.12.83 A.Ho
*	2:1	Ausgabe Datum Gez. Gepr. Ges. Index
Ersatz für:	Ersetzt durch:	Kopie für:
STUDER REGENSDORF ZÜRICH	Benennung: HL ST. INP. UNIT B	Nummer: 1.942.140-00

IND.	POS.NO.	PART NO.	VALUE	SPECIFICATIONS / EQUIVALENT		MANUF.
		C...101	59.05.1681	680 pF	1%	500V PP
		C...102	59.05.1681	680 pF	1%	500V PP
(03)		C...103	59.06.0682	6,8 nF	10%	50V PE
		C...104	59.34.5391	390 pF	5%	CE
		C...105	59.22.4101	100 uF	-20%	16V EL
		C...106	59.22.2221	220 uF	-20%	6V EL
		C...107	59.22.4101	100 uF	-20%	16V EL
		C...108	59.22.2221	220 uF	-20%	6V EL
		C...109	59.34.2220	22 pF	5%	CE
		C...110	59.34.2220	22 pF	5%	CE
		C...111	59.22.4101	100 uF	-20%	16V EL
		C...112		not exist		
		C...113	59.22.4101	100 uF	-20%	16V EL
		C...114	59.22.4101	100 uF	-20%	16V EL
		C...115		not used		
		C...116	59.34.2220	22 pF	5%	CE
		C...117	59.22.4101	100 uF	-20%	16V EL
		C...118		not exist		
		C...119	59.22.4101	100 uF	-20%	16V EL
		C...120		not exist		
		C...121		not used		
		C...122	59.34.2220	22 pF	5%	CE
		C...123	59.22.4101	100 uF	-20%	16V EL
		C...124	59.22.4101	100 uF	-20%	16V EL
		C...125		not exist		
		C...126		not used		
		C...127	59.34.2220	22 pF	5%	CE
		C...128	59.22.4101	100 uF	-20%	16V EL
(01)		C...129		not used		
(01)		C...130		not used		
(01)		C...131		not used		
		C...132	59.06.0682	6.8 nF		50V PE
		C...133	59.06.0682	6.8 nF		50V PE
		C...134	59.06.0682	* 6.8 nF		50V PE
		C...135	59.06.0682	* 6.8 uF		50V PE
		C...136	59.06.0682	6.8 nF		50V PE
		C...137	59.06.0682	6.8 nF		50V PE

S T U D E R (03) 84/12/01 TA HL-ST-INPUT-UNIT-B-4CH/8CH 1.912.141.00 PAGE 1

IND.	POS.NO.	PART NO.	VALUE	SPECIFICATIONS / EQUIVALENT		MANUF.
		C...138	59.34.4221	220 pF	5%	CE
		C...139	59.34.4221	220 pF	5%	CE
(01)		C...140		not used		
		C...201	59.05.1681	680 pF	1%	500V PP
(03)		C...202	59.05.1681	680 pF	1%	500V PP
		C...203	59.06.0682	6,8 nF	10%	50V PE
		C...204	59.34.5391	390 pF	5%	CE
		C...205	59.22.4101	100 uF	-20%	16V EL
		C...206	59.22.2221	220 uF	-20%	6V EL
		C...207	59.22.4101	100 uF	-20%	16V EL
		C...208	59.22.2221	220 uF	-20%	6V EL
		C...209	59.34.2220	22 pF	5%	CE
		C...210	59.34.2220	22 pF	5%	CE
		C...211	59.22.4101	100 uF	-20%	16V EL
		C...212		not exist		
		C...213	59.22.4101	100 uF	-20%	16V EL
		C...214	59.22.4101	100 uF	-20%	16V EL
		C...215		not used		
		C...216	59.34.2220	22 pF	5%	CE
		C...217	59.22.4101	100 uF	-20%	16V EL
		C...218		not exist		
		C...219	59.22.4101	100 uF	-20%	16V EL
		C...220		not exist		
		C...221		not used		
		C...222	59.34.2220	22 pF	5%	CE
		C...223	59.22.4101	100 uF	-20%	16V EL
		C...224	59.22.4101	100 uF	-20%	16V EL
		C...225		not exist		
		C...226		not used		
		C...227	59.34.2220	22 pF	5%	CE
		C...228	59.22.4101	100 uF	-20%	16V EL
(01)		C...229		not used		
(01)		C...230		not used		
(01)		C...231		not used		
		C...232	59.06.0682	6.8 nF		50V PE
		C...233	59.06.0682	6.8 nF		50V PE
		C...234	59.06.0682	* 6.8 nF		50V PE

S T U D E R (03) 84/12/01 TA HL-ST-INPUT-UNIT-B-4CH/8CH 1.912.141.00 PAGE 2

IND.	POS.NO.	PART NO.	VALUE	SPECIFICATIONS / EQUIVALENT	MANUF.
	C...235	59.06.0682	* 6.8 uF	50V PE	
	C...236	59.06.0682	6.8 nF	50V PE	
	C...237	59.06.0682	6.8 nF	50V PE	
	C...238	59.34.4221	220 pF	5% CE	
	C...239	59.34.4221	220 pF	5% CE	
(01)	C...240		not used		
	C...301		not used		
	C...302		not used		
	C...303	59.22.4101	100 uF	-20% 16V EL	
	C...304	59.06.0223	22 nF	10% 50V PE	
(01)	C...305	59.06.0223	22 nF	10% 50V PE	
	C...306		not used		
	C...307		not used		
	C...308		not used		
	C...309		not used		
	C...310	59.06.0223	22 nF	10% 50V PE	
	C...311		not used		
	C...312	59.06.0223	22 nF	10% 50V PE	
	C...313		not used		
(02)	C...314	59.34.4101	100 pF	5% CE	
	C...315		not used		
	C...316		not used		
	C...317		not used		
	C...318	59.22.4101	100 uF	-20% 16V EL	
	C...319	59.22.4101	100 uF	-20% 16V EL	
	C...320	59.06.0223	22 nF	10% 50V PE	
	C...321		not used		
	C...322		not used		
	C...323		not used		
	C...324		not used		
(01)	C...325		not used		
(01)	C...401		not used		
(01)	C...402		not used		
(01)	C...501		not used		
(01)	C...502		not used		
	C...503		not used		
	C...504		not used		

S T U D E R (03) 84/12/01 TA HL-ST-INPUT-UNIT-B-4CH/8CH 1.912.141.00 PAGE 3

IND.	POS.NO.	PART NO.	VALUE	SPECIFICATIONS / EQUIVALENT	MANUF.
(01)	C...505		not used		
	C...506		not used		
	C...507		not used		
	D...101	50.04.0125	1N4448		any
	D...102	50.04.0125	1N4448		any
	D...103	50.04.0125	1N4448		any
	D...104	50.04.0125	1N4448		any
	D...105	50.04.0125	* 1N4448		any
	D...106	50.04.0125	* 1N4448		any
	D...107	50.04.0125	1N4448		any
	D...108	50.04.0125	1N4448		any
	D...201	50.04.0125	1N4448		any
	D...202	50.04.0125	1N4448		any
	D...203	50.04.0125	1N4448		any
	D...204	50.04.0125	1N4448		any
	D...205	50.04.0125	* 1N4448		any
	D...206	50.04.0125	* 1N4448		any
	D...207	50.04.0125	1N4448		any
	D...208	50.04.0125	1N4448		any
	D...301	50.04.0125	1N4448		any
	D...302	50.04.1112	Z 5.1V	400mW BZX83C 5.1, BZX55C 5.1, ZPD 5.1	
	D...303	50.04.0125	1N4448		any
	D...304	50.04.0125	1N4448		any
	D...305	50.04.0125	1N4448		any
	D...306	50.04.0125	1N4448		any
(01)	D...307		not used		
	D...308	50.04.0125	1N4448		any
(01)	D...309		not used		
	DL...301	50.04.2111	MV5753	red	GI,HP
	DL...302	50.04.2111	MV5753	red	GI,HP
	IC...101	50.09.0106	NE5532AN	dual op. amp. low noise	Siq,Ex,Ra
	IC...102	50.05.0243	NE5534N	single op. amp.	TI,Sig,Ra
	IC...103	50.05.0243	NE5534N	single op. amp.	TI,Sig,Ra
	IC...104	50.05.0243	NE5534N	single op. amp.	TI,Sig,Ra

S T U D E R (03) 84/12/01 TA HL-ST-INPUT-UNIT-B-4CH/8CH 1.912.141.00 PAGE 4

IND.	POS.NO.	PART NO.	VALUE	SPECIFICATIONS / EQUIVALENT	MANUF.
	IC..105	50.05.0243	NE5534N	single op. amp.	TI,Sig,Ra
(01)	IC..106		not used		
	IC..201	50.09.0106	NE5532AN	dual op. amp. low noise	Sig,Ex,Ra
	IC..202	50.05.0243	NE5534N	single op. amp.	TI,Sig,Ra
	IC..203	50.05.0243	NE5534N	single op. amp.	TI,Sig,Ra
	IC..204	50.05.0243	NE5534N	single op. amp.	TI,Sig,Ra
	IC..205	50.05.0243	NE5534N	single op. amp.	TI,Sig,Ra
(01)	IC..206		not used		
(01)	IC..301		not used		
	IC..302	50.05.0158	NE 555	timer	Sig,Mot,NSC
	IC..303	50.07.0081	CD4081	2 input and-gate CMOS	Fc,Mot,RCA
	IC..304	50.07.0049	CD4049	hex. inverter CMOS	Fc,Mot
	IC..305	50.05.0243	NE5534N	single op. amp.	TI,Sig,Ra
(01)	IC..501		not used		
	P.....3	54.11.2007	2*8 pin	euroconnector	Bu
	P.....4	54.01.0359	2*16pin	euroconnector	Bu
	P.....6	54.01.0359	2*16pin	euroconnector	Bu
	Q...101	50.03.0350	J 112	N-JFET	NS,Mot,Six
	Q...102	50.03.0350	J 112	N-JFET	NS,Mot,Six
(01)	Q...103		not used		
	Q...104	50.03.0350	J 112	N-JFET	NS,Mot,Six
	Q...105	50.03.0350	J 112	N-JFET	NS,Mot,Six
	Q...106	50.03.0350	J 112	N-JFET	NS,Mot,Six
	Q...107	50.03.0350	J 112	N-JFET	NS,Mot,Six
	Q...108	50.03.0350	* J 112	N-JFET	NS,Mot,Six
	Q...109	50.03.0350	* J 112	N-JFET	NS,Mot,Six
	Q...110	50.03.0350	* J 112	N-JFET	NS,Mot,Six
	Q...111	50.03.0350	* J 112	N-JFET	NS,Mot,Six
	Q...112	50.03.0350	J 112	N-JFET	NS,Mot,Six
	Q...113	50.03.0350	J 112	N-JFET	NS,Mot,Six
	Q...114	50.03.0350	J 112	N-JFET	NS,Mot,Six
	Q...201	50.03.0350	J 112	N-JFET	NS,Mot,Six
	Q...202	50.03.0350	J 112	N-JFET	NS,Mot,Six
(01)	Q...203		not used		
	Q...204	50.03.0350	J 112	N-JFET	NS,Mot,Six

S T U D E R (03) 84/12/01 TA HL-ST-INPUT-UNIT-B-4CH/8CH 1.912.141.00 PAGE 5

IND.	POS.NO.	PART NO.	VALUE	SPECIFICATIONS / EQUIVALENT	MANUF.
	Q...205	50.03.0350	J 112	N-JFET	NS,Mot,Six
	Q...206	50.03.0350	J 112	N-JFET	NS,Mot,Six
	Q...207	50.03.0350	J 112	N-JFET	NS,Mot,Six
	Q...208	50.03.0350	* J 112	N-JFET	NS,Mot,Six
	Q...209	50.03.0350	* J 112	N-JFET	NS,Mot,Six
	Q...210	50.03.0350	* J 112	N-JFET	NS,Mot,Six
	Q...211	50.03.0350	* J 112	N-JFET	NS,Mot,Six
	Q...212	50.03.0350	J 112	N-JFET	NS,Mot,Six
	Q...213	50.03.0350	J 112	N-JFET	NS,Mot,Six
	Q...214	50.03.0350	J 112	N-JFET	NS,Mot,Six
	Q...301	50.03.0350	J 112	N-JFET	NS,Mot,Six
	Q...302	50.03.0350	J 112	N-JFET	NS,Mot,Six
	Q...303	50.03.0350	J 112	N-JFET	NS,Mot,Six
	Q...304	50.03.0350	J 112	N-JFET	NS,Mot,Six
	Q...305		BC 307	PNP IC>100mA, B>100 50030515	any
	R...101	57.11.3152	1.5 kOhm	1% 0.25W	
	R...102	57.11.3392	3.9 kOhm	1% 0.25W	
	R...103	57.11.3152	1.5 kOhm	1% 0.25W	
	R...104	57.11.3392	3.9 kOhm	1% 0.25W	
(01)	R...105	57.11.3392	3.9 kOhm	5% 0.25W	
	R...106	57.11.4331	330 Ohm	5% 0.25W	
	R...107	57.11.4472	4.7 kOhm	5% 0.25W	
	R...108	57.11.3153	15 kOhm	5% 0.25W	
	R...109	58.01.8502	5 kOhm	10%	
	R...110	57.11.4122	1.2 kOhm	5% 0.25W	
	R...111	57.11.4472	4.7 kOhm	5% 0.25W	
	R...112	57.11.3132	1.3 kOhm	5% 0.25W	
(01)	R...113	1.010.007.58	10 kOhm	10% lin. combined with R 213	St
	R...114	57.11.3132	1.3 kOhm	5% 0.25W	
	R...115	57.11.4472	4.7 kOhm	5% 0.25W	
	R...116	57.11.4333	33 kOhm	5% 0.25W	
	R...117	57.11.4682	6.8 kOhm	5% 0.25W	
	R...118	57.11.4104	100 kOhm	5% 0.25W	
	R...119	57.11.4104	100 kOhm	5% 0.25W	
	R...120	57.11.4104	100 kOhm	5% 0.25W	
	R...121	57.11.4104	100 kOhm	5% 0.25W	

S T U D E R (03) 84/12/01 TA HL-ST-INPUT-UNIT-B-4CH/8CH 1.912.141.00 PAGE 6

IND.	POS.NO.	PART NO.	VALUE	SPECIFICATIONS / EQUIVALENT	MANUF.
	R...122	57.11.4682	6.8 kOhm	5% 0.25W	
	R...123	57.11.4330	33 Ohm	5% 0.25W	
	R...124	57.11.4333	33 kOhm	5% 0.25W	
	R...125	57.11.3153	15 kOhm	1% 0.25W	
	R...126	57.11.4333	33 kOhm	5% 0.25W	
	R...127	1.010.004.58	10 kOhm	10% pos.log.variable resistor	St
	R...128	57.11.4682	6.8 kOhm	5% 0.25W	
	R...129	57.11.3132	1.3 kOhm	5% 0.25W	
	R...130	57.11.4332	3.3 kOhm	5% 0.25W	
	R...131	57.11.4472	4.7 kOhm	5% 0.25W	
	R...132	57.11.4333	33 kOhm	5% 0.25W	
	R...133	57.11.4332	3.3 kOhm	5% 0.25W	
	R...134	57.11.4332	3.3 kOhm	5% 0.25W	
	R...135	57.11.4333	33 kOhm	5% 0.25W	
	R...136	57.11.4472	4.7 kOhm	5% 0.25W	
	R...137	57.11.4393	39 kOhm	5% 0.25W	
	R...138	57.11.4333	33 kOhm	5% 0.25W	
	R...139	57.11.4472	4.7 kOhm	5% 0.25W	
	R...140	57.11.4333	33 kOhm	5% 0.25W	
	R...141	1.010.008.58	10 kOhm	10% pos.log.variable resistor	St
	R...142	57.11.4332	3.3 kOhm	5% 0.25W	
(01)	R...143		not used		
(01)	R...144		not used		
(01)	R...145		not used		
(01)	R...146		not used		
	R...147		33 kOhm	5% 0.25W	57114333 option 2
	R...148	57.11.4332	3.3 kOhm	5% 0.25W	
	R...149	57.11.4104	100 kOhm	5% 0.25W	
	R...150	57.11.4104	100 kOhm	5% 0.25W	
	R...151	57.11.4104	100 kOhm	5% 0.25W	
	R...152	57.11.4104	100 kOhm	5% 0.25W	
	R...153	57.11.4332	3.3 kOhm	5% 0.25W	
	R...154	57.11.4104	100 kOhm	5% 0.25W	
	R...155	57.11.4104	100 kOhm	5% 0.25W	
	R...156	57.11.4104	100 kOhm	5% 0.25W	
	R...157	57.11.4104	100 kOhm	5% 0.25W	
	R...158	57.11.4332	*3.3 kOhm	5% 0.25W	

S T U D E R (03) 84/12/01 TA HL-ST-INPUT-UNIT-B-4CH/8CH 1.912.141.00 PAGE 7

IND.	POS.NO.	PART NO.	VALUE	SPECIFICATIONS / EQUIVALENT	MANUF.
	R...159	57.11.4104	*100 kOhm	5% 0.25W	
	R...160	57.11.4104	*100 kOhm	5% 0.25W	
	R...161	57.11.4104	*100 kOhm	5% 0.25W	
	R...162	57.11.4104	*100 kOhm	5% 0.25W	
	R...163	57.11.4332	*3.3 kOhm	5% 0.25W	
	R...164	57.11.4104	*100 kOhm	5% 0.25W	
	R...165	57.11.4104	*100 kOhm	5% 0.25W	
	R...166	57.11.4104	*100 kOhm	5% 0.25W	
	R...167	57.11.4104	*100 kOhm	5% 0.25W	
	R...168	57.11.4103	10 kOhm	5% 0.25W	
	R...169	57.11.4104	100 kOhm	5% 0.25W	
	R...170	57.11.4104	100 kOhm	5% 0.25W	
	R...171	57.11.4103	10 kOhm	5% 0.25W	
	R...172	57.11.4104	100 kOhm	5% 0.25W	
	R...173	57.11.4104	100 kOhm	5% 0.25W	
	R...174	57.11.4104	100 kOhm	5% 0.25W	
	R...175	57.11.4332	3.3 kOhm	5% 0.25W	
	R...176	57.11.3362	3.6 kOhm	5% 0.25W	
	R...201	57.11.3152	1.5 kOhm	1% 0.25W	
	R...202	57.11.3392	3.9 kOhm	1% 0.25W	
	R...203	57.11.3152	1.5 kOhm	1% 0.25W	
	R...204	57.11.3392	3.9 kOhm	1% 0.25W	
(01)	R...205	57.11.3392	3.9 kOhm	5% 0.25W	
	R...206	57.11.4331	330 Ohm	5% 0.25W	
	R...207	57.11.4472	4.7 kOhm	5% 0.25W	
	R...208	57.11.3153	15 kOhm	5% 0.25W	
	R...209	58.01.8502	5 kOhm	10%	
	R...210	57.11.4122	1.2 kOhm	5% 0.25W	
	R...211	57.11.4472	4.7 kOhm	5% 0.25W	
	R...212	57.11.3132	1.3 kOhm	5% 0.25W	
(01)	R...213	1.010.007.58	10 kOhm	20% lin. combined with R 113	St
	R...214	57.11.3132	1.3 kOhm	5% 0.25W	
	R...215	57.11.4472	4.7 kOhm	5% 0.25W	
	R...216	57.11.4333	33 kOhm	5% 0.25W	
	R...217	57.11.4682	6.8 kOhm	5% 0.25W	
	R...218	57.11.4104	100 kOhm	5% 0.25W	
	R...219	57.11.4104	100 kOhm	5% 0.25W	

S T U D E R (03) 84/12/01 TA HL-ST-INPUT-UNIT-B-4CH/8CH 1.912.141.00 PAGE 8

IND.	POS.NO.	PART NO.	VALUE	SPECIFICATIONS / EQUIVALENT	MANUF.
	R...220	57.11.4104	100 kOhm	5% 0.25W	
	R...221	57.11.4104	100 kOhm	5% 0.25W	
	R...222	57.11.4682	6.8 kOhm	5% 0.25W	
	R...223	57.11.4330	33 Ohm	5% 0.25W	
	R...224	57.11.4333	33 kOhm	5% 0.25W	
	R...225	57.11.3153	15 kOhm	1% 0.25W	
	R...226	57.11.4333	33 kOhm	5% 0.25W	
	R...227	1.010.004.58	10 kOhm	10% pos.log.variable resistor	St
	R...228	57.11.4682	6.8 kOhm	5% 0.25W	
	R...229	57.11.3132	1.3 kOhm	5% 0.25W	
	R...230	57.11.4332	3.3 kOhm	5% 0.25W	
	R...231	57.11.4472	4.7 kOhm	5% 0.25W	
	R...232	57.11.4333	33 kOhm	5% 0.25W	
	R...233	57.11.4332	3.3 kOhm	5% 0.25W	
	R...234	57.11.4332	3.3 kOhm	5% 0.25W	
	R...235	57.11.4333	33 kOhm	5% 0.25W	
	R...236	57.11.4472	4.7 kOhm	5% 0.25W	
	R...237	57.11.4393	39 kOhm	5% 0.25W	
	R...238	57.11.4333	33 kOhm	5% 0.25W	
	R...239	57.11.4472	4.7 kOhm	5% 0.25W	
	R...240	57.11.4333	33 kOhm	5% 0.25W	
	R...241	1.010.008.58	10 kOhm	10% pos.log.variable resistor	St
	R...242	57.11.4332	3.3 kOhm	5% 0.25W	
(01)	R...243		not used		
(01)	R...244		not used		
(01)	R...245		not used		
(01)	R...246		not used		
(01)	R...247		not used		
	R...248	57.11.4332	3.3 kOhm	5% 0.25W	
	R...249	57.11.4104	100 kOhm	5% 0.25W	
	R...250	57.11.4104	100 kOhm	5% 0.25W	
	R...251	57.11.4104	100 kOhm	5% 0.25W	
	R...252	57.11.4104	100 kOhm	5% 0.25W	
	R...253	57.11.4332	3.3 kOhm	5% 0.25W	
	R...254	57.11.4104	100 kOhm	5% 0.25W	
	R...255	57.11.4104	100 kOhm	5% 0.25W	
	R...256	57.11.4104	100 kOhm	5% 0.25W	

S T U D E R (03) 84/12/01 TA HL-ST-INPUT-UNIT-B-4CH/8CH 1.912.141.00 PAGE 9

IND.	POS.NO.	PART NO.	VALUE	SPECIFICATIONS / EQUIVALENT	MANUF.
	R...257	57.11.4104	100 kOhm	5% 0.25W	
	R...258	57.11.4332	*3.3 kOhm	5% 0.25W	
	R...259	57.11.4104	*100 kOhm	5% 0.25W	
	R...260	57.11.4104	*100 kOhm	5% 0.25W	
	R...261	57.11.4104	*100 kOhm	5% 0.25W	
	R...262	57.11.4104	*100 kOhm	5% 0.25W	
	R...263	57.11.4332	*3.3 kOhm	5% 0.25W	
	R...264	57.11.4104	*100 kOhm	5% 0.25W	
	R...265	57.11.4104	*100 kOhm	5% 0.25W	
	R...266	57.11.4104	*100 kOhm	5% 0.25W	
	R...267	57.11.4104	*100 kOhm	5% 0.25W	
	R...268	57.11.4103	10 kOhm	5% 0.25W	
	R...269	57.11.4104	100 kOhm	5% 0.25W	
	R...270	57.11.4104	100 kOhm	5% 0.25W	
	R...271	57.11.4103	10 kOhm	5% 0.25W	
	R...272	57.11.4104	100 kOhm	5% 0.25W	
	R...273	57.11.4104	100 kOhm	5% 0.25W	
	R...274	57.11.4104	100 kOhm	5% 0.25W	
	R...275	57.11.4332	3.3 kOhm	5% 0.25W	
	R...276	57.11.3362	3.6 kOhm	5% 0.25W	
	R...301	57.11.3472	4.7 kOhm	1% 0.25W	
	R...302	57.11.3472	4.7 kOhm	1% 0.25W	
	R...303	57.11.3473	47 kOhm	1% 0.25W	
	R...304	57.11.3473	47 kOhm	1% 0.25W	
	R...305	57.11.4333	33 kOhm	5% 0.25W	
	R...307	57.11.3202	2 kOhm	1% 0.25W	
	R...308	57.11.4104	100 kOhm	5% 0.25W	
	R...309	57.11.4104	100 kOhm	5% 0.25W	
	R...310	57.11.4104	100 kOhm	5% 0.25W	
	R...311	57.11.4105	1 MOhm	5% 0.25W	
	R...312	57.11.4104	100 kOhm	5% 0.25W	
	R...313	57.11.4104	100 kOhm	5% 0.25W	
	R...314	57.11.4104	100 kOhm	5% 0.25W	
	R...315	57.11.4105	1 MOhm	5% 0.25W	
	R...316	57.11.4104	100 kOhm	5% 0.25W	
	R...317	57.11.4104	100 kOhm	5% 0.25W	
	R...318	57.11.4102	1 kOhm	5% 0.25W	

S T U D E R (03) 84/12/01 TA HL-ST-INPUT-UNIT-B-4CH/8CH 1.912.141.00 PAGE 10

IND.	POS.NO.	PART NO.	VALUE	SPECIFICATIONS / EQUIVALENT	MANUF.
	R...319	57.11.4331	330 Ohm	5% 0.25W	
	R...320	57.11.4103	10 kOhm	5% 0.25W	
	R...321	57.11.4335	3.3 MOhm	5% 0.25W	
	R...322	57.11.4104	100 kOhm	5% 0.25W	
	R...323	57.11.4104	100 kOhm	5% 0.25W	
(01)	R...324		not used		
(01)	R...325		not used		
(01)	R...326		not used		
(01)	R...327	57.11.4105	1 MOhm	5% 0.25W	
(01)	R...328		not used		
	R...329	57.11.4331	330 Ohm	5% 0.25W	
	R...330	57.11.4103	10 kOhm	5% 0.25W	
	R...331	57.11.4681	680 Ohm	5% 0.25W	
	R...332	57.11.4102	1 kOhm	5% 0.25W	
	R...333	1.369.150.03	10 kOhm	20% pos.log.variable resistor	St
	R...334	1.369.150.03	10 kOhm	20% pos.log.variable resistor	St
	R...335	1.369.150.03	10 kOhm	20% pos.log.variable resistor	St
	R...336	57.11.4332	3.3 kOhm	5% 0.25W	
	R...337	57.11.4332	3.3 kOhm	5% 0.25W	
	R...338	57.11.4332	3.3 kOhm	5% 0.25W	
	R...339	57.11.4471	470 Ohm	5% 0.25W	
	R...340	57.99.0209	5.6 Ohm	PTC Philips Nr.2322 662 91005	
	R...341	57.99.0209	5.6 Ohm	PTC Philips Nr.2322 662 91005	
	R...342	57.99.0209	5.6 Ohm	PTC Philips Nr.2322 662 91005	
	R...343	57.99.0206	50 Ohm	PTC Philips Nr.2322 660 91008	
	R...344	57.11.4102	1 kOhm	5% 0.25W	
	R...345	57.11.4104	100 kOhm	5% 0.25W	
(01)	R...346		not exist		
(01)	R...401		not used		
(01)	R...402		not used		
(01)	R...403		not used		
(01)	R...404		not used		
(01)	R...501		not used		
(01)	R...502		not used		
(01)	R...503		not used		
(01)	R...504		not used		
(01)	R...505		not used		

S T U D E R (03) 84/12/01 TA HL-ST-INPUT-UNIT-B-4CH/8CH 1.912.141.00 PAGE 11

IND.	POS.NO.	PART NO.	VALUE	SPECIFICATIONS / EQUIVALENT	MANUF.
(01)	R...506		not used		
(01)	R...507		not used		
(01)	R...508		not used		
	S...101	55.15.0004	4*U	2u gold button: 55150106 red	
	S...102			combined with S101	
	S...103	55.15.0002	* 2*U	button: 55030303 red	ITT
	S...104	55.15.0002	2*U	button: 55030303 red	ITT
	S...105	55.15.0002	2*U	button: 55030303 red	ITT
	S...106	55.15.0002	* 2*U	button: 55030303 red	ITT
	S...107	1.010.008.59	1*U	combined with variable resistor R 141/241	St
	S...201			combined with S101	
	S...202			combined with S101	
	S...203		*	combined with S103	
	S...204			combined with S104	
	S...205			combined with S105	
	S...206		*	combined with S106	
	S...207	1.010.008.59	1*U	combined with variable resistor R 141/241	St
	S...301	1.912.120.03	2*U	button: 55030303 red	
	S...302			combined with S301	
	S...303		2*U	mutual realising with S301/S302	
	S...304			combined with S303	
	S...305	55.15.0012	2*U	button: 55150106 red	
	S...306			combined with S305	
	S...307	1.369.150.03	1*U	combined with variable resistor R 333	St
	S...308	1.369.150.03	1*U	combined with variable resistor R 334	St
	S...309	1.369.150.03	1*U	combined with variable resistor R 335	St
	T...101	1.022.451.00		input trafo 1:0.62	St
	T...201	1.022.451.00		input trafo 1:0.62	St
	W.....1			by 8-CH not equipped	
	W.....2			by 8-CH not equipped	
	W.....3			by 8-CH not equipped	
	W.....4			by 8-CH not equipped	

(01) XDL.301

S T U D E R (03) 84/12/01 TA HL-ST-INPUT-UNIT-B-4CH/8CH 1.912.141.00 PAGE 12

IND.	POS.NO.	PART NO.	VALUE	SPECIFICATIONS / EQUIVALENT	MANUF.
(01)	XDL.302 XDL....	1.010.012.50		LED-holder	St

(01) 84/03/01 click suppression of attenuator

(02) 84/10/04 suppression of high frequency

=====
 * ONLY 8-CHANNEL 1.912.143.00
 =====

CE=Ceramic, CF=Carbon Film, EL=Electrolytic, MF=Metal Film,
 PE=Polyester, PP=Polypropylen, PS=Polystyrol

MANUFACTURER: Bu=Burndy, Ex=Exar, Fc=Fairchild, GI=General Instrument
 HP=Hewlett Packard, ITT=Intermetall, Mot=Motorola,
 NS=National Semiconductors, Ph=Philips, Ra=Raytheon,
 Sig=Signetics, Six=Siliconix, St=Studer,
 TI=Texas Instrument

ORIG 83/01/20 (01) 84/03/01 (02) 84/10/04 (03) 84/12/01

S T U D E R (03) 84/12/01 TA HL-ST-INPUT-UNIT-B-4CH/8CH 1.912.141.00 PAGE 13

Hilfssummeneinheit

Die drei Mono-Hilfsausgänge (AUX 1...3) und der Stereo-Hilfsausgang (AUX 4) der Eingangseinheiten werden über Sammelschienen den Hilfssummeneinheiten zugeführt und dort auf Nominalpegel verstärkt.

Vor dem Summenregler (SEND) kann das Signal durch ein Hochpassfilter mit variabler Grenzfrequenz geführt, und über PFL vorgehört werden. Die MUTE-Taste unterbricht den Signalweg. Befehle können über das Kommandomikrofon mit der TALK BACK-Taste direkt auf jede Hilfssumme gegeben werden.

Filter	Variables Hochpassfilter mit einer Steilheit von 12dB pro Oktave. Grenzfrequenz einstellbar von 30...330Hz.
Send	Summenpegelregler
Talk Back	Gegensprechen auf den betreffenden AUX-Kanal. Bei gedrückter Talk Back-Taste wird das AUX-Signal um 20 dB gedämpft.
Mute	Stummschaltung der Hilfssumme
PFL	Vorhören der Hilfssumme

Ausgangspegel	+6dBu @ 600Ω
Speisung	± 15 V / 200 mA - 6 V / 1...80 mA - 24 V / < 8 mA

Blockdiagramm

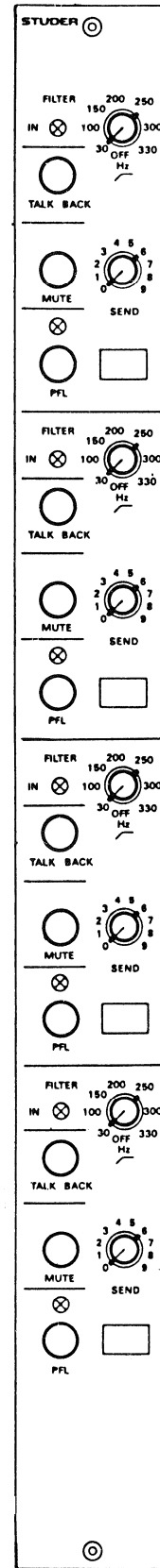
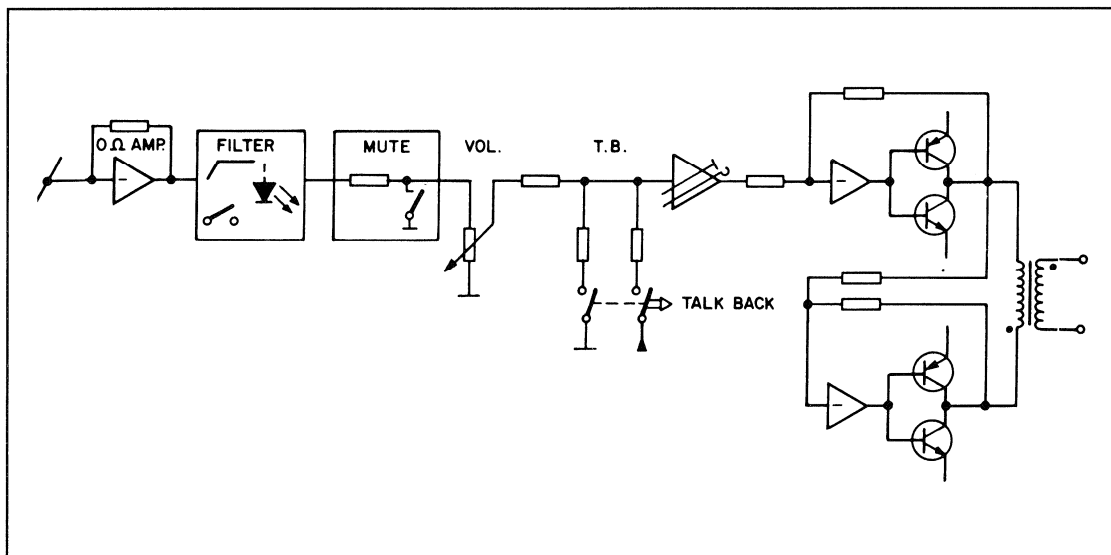

AUX MASTER

Auxiliary master unit

The three mono auxiliary outputs (AUX 1...3) and the stereo auxiliary output (AUX 4) of the output units get fed to the auxiliary master units by the bus bars and there they get amplified to normal level.

Before the master control (SEND), the signal can be led through a high-pass filter with variable cutoff frequency, and it can be pre-listened over PFL. The MUTE push button interrupts the signal path. Orders can directly be given to each auxiliary master by the command microphone with the TALK BACK push button.

Filter	High-pass filter with 12 dB/octave slope. The attack frequency can be varied from 30 Hz to 330 Hz.
Send	Master level control
Talk back	Talk back to the referring auxiliary channel. The talk back key activates damping of 20dB on the AUX signal.
Mute	Push button for muting the AUX channel.
PFL	Pre-listening of the AUX channel

Output level +6 dBu @ 600Ω

Supply ± 15 V / 200 mA
 - 6 V / 1...80 mA
 - 24 V / < 8 mA

Block diagram

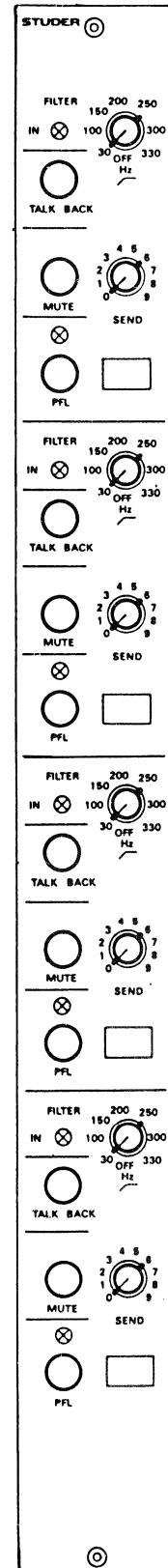
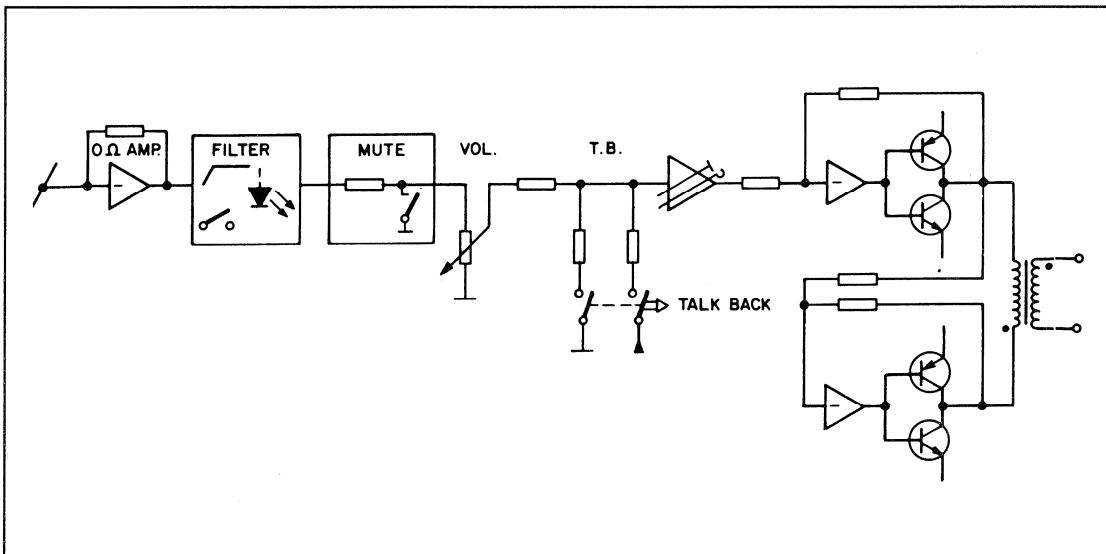

Auxiliary Unit 1.912.310

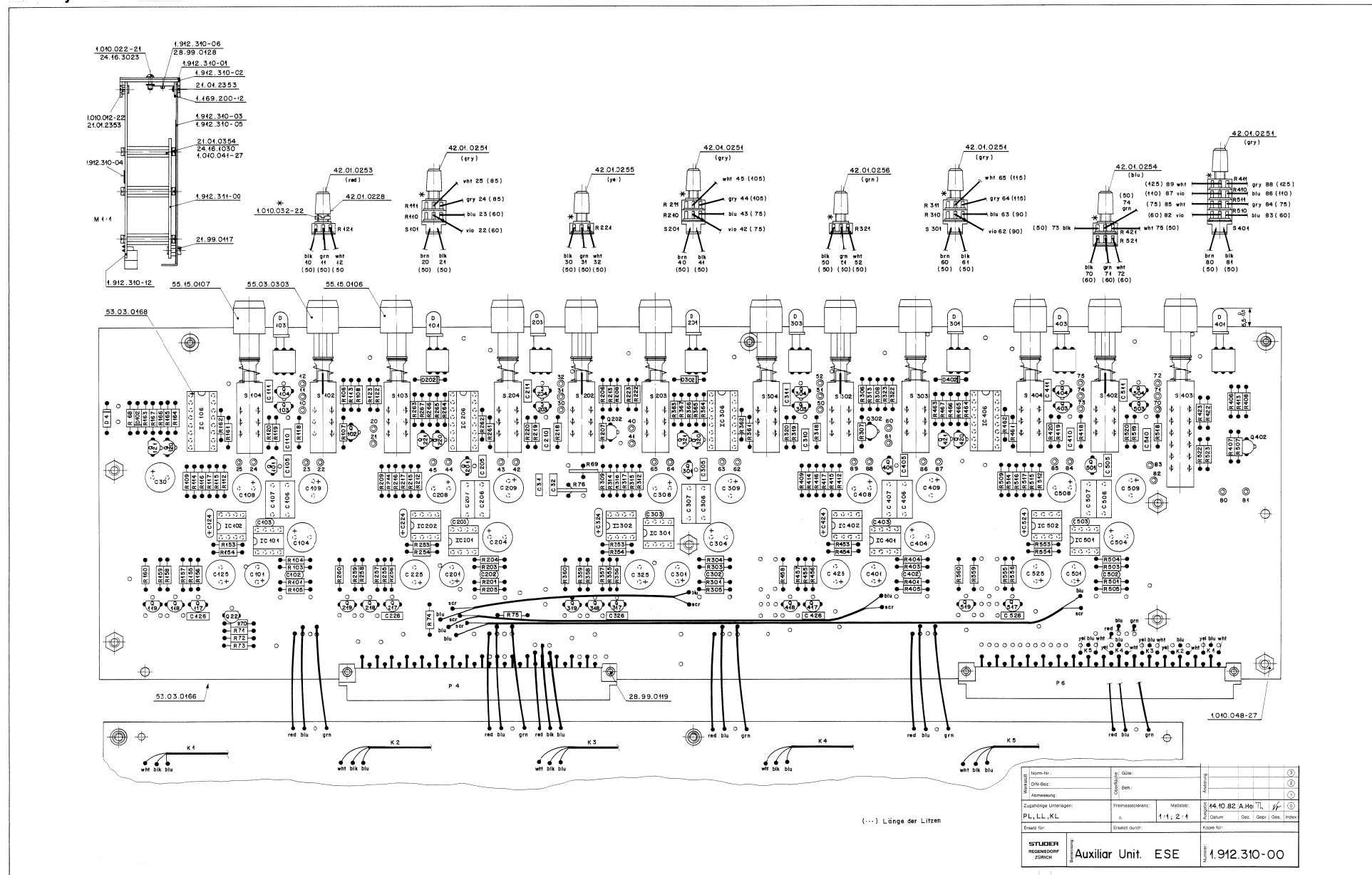

Norm-Nr.:	44.10 B2 A.Ho	Date:	
DN-Bez.:	PL, LL, KL	Ben.:	
Abteilung:		Projektant:	
Superviseur:		Prüfingenieur:	
Maltes:	1:1, 2:1	Zeichn.:	
Erstellt durch:		Doc.:	
Blatt-Nr.:		Blatt:	
STUDER REGENSCHEDE ZÜRICH		Auxiliary Unit. ESE	
		1.912.310-00	

Auxiliary Unit 1.912.310

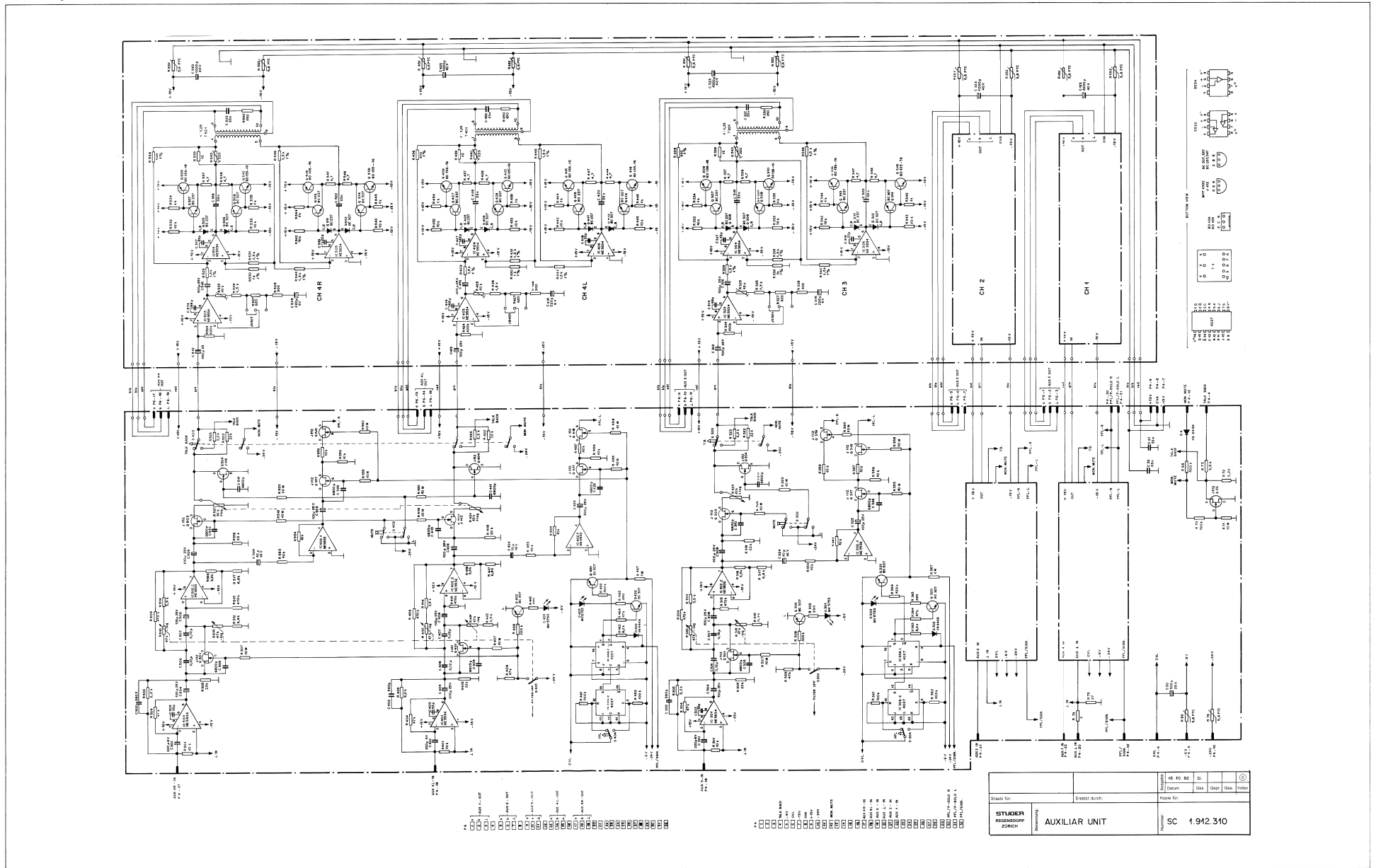

Auxiliary Unit 1.912.310

IND POS NO	PART NO	VALUE	SPECIFICATIONS/EQUIVALENT	MFR
C_01	59.22.2221	220 μ	6V EL	
.02	59.34.5561	560 p	CER	
.03	59.34.2330	33 p	CER	
.04	59.22.5101	100 μ	25V EL	
.05	59.06.0682	6800 p	63V PE	
.06	59.02.2174	0.12 μ	5% PE	
.07	59.02.2124	0.12 μ	5% PE	
.08	59.22.5101	100 μ	25V EL	
.09	59.22.5101	100 μ	25V EL	
.10	59.06.0682	6800 p	63V PE	
.11	59.06.0682	6800 p	63V PE	
.12	59.22.5101	100 μ	25V EL	
.13				
.14	59.34.4680	68 p	CER	
.15	59.22.2221	220 μ	6V EL	
.16	59.22.5101	100 μ	25V EL	
.17	59.34.2220	22 p	CER	
.18	59.06.0333	0.033 μ	63V PE	
.19	59.34.2220	22 p	CER	
.20	59.06.0333	0.033 μ	63V PE	
.21				
.22	59.06.0333	0.033 μ	63V PE	
.23	59.25.5102	1000 μ	46V EL	
.24	59.26.2103	10 μ	46V SAL	
.25	59.25.5101	100 μ	25V EL	
.26	59.06.0682	6800 p	63V PE	
.27				
.28				
.29				
30	59.22.5101	100 μ	25V EL	

IND	DATE	NAME
IG		CER GERMANIC
EL		EL ELECTROLYTIC
PC	1.2.85	PC POLYCARBONAT
PE	30.1.84	PE POLYESTER
SAL	24.9.82	SAL SOLID ALUMINIUM

STUDER AUXILIAR UNIT | 1.912.310.00 | page 1 of 6
13046510

IND POS NO	PART NO	VALUE	SPECIFICATIONS/EQUIVALENT	MFR
C_31	59.06.0333	0.033 μ	63V PE	
32	59.06.0333	0.033 μ	63V PE	
01	50.04.2111	MV5753	LED RED	IR
.02	50.04.0125	IN4448		
.03	50.04.2111	MV5753	LED RED	IR
4	50.04.0125	IN4448		
IC_01	50.05.0244	NE 5534A	OP-AMP DIP 8	S16
.02	50.09.0105	NE 5532	DUAL OP-AMP DIP 8	.
.03	50.05.0243	NE 5534	OP-AMP DIP 8	.
.04	50.05.0243	NE 5534	OP-AMP DIP 8	.
.05	50.05.0243	NE 5534	OP-AMP DIP 8	.
.06	50.07.0027	4027	DUAL J-K FF	M05
IC_01	54.01.0020	PIN		
	54.01.0021	JUMPER		
P_4	54.01.0359	2*16p		
6	54.01.0359	2*16p		
Q_01	50.03.0350	J112	J-FET	Sx
.02	50.03.0515	BC307	PNP	BC 557
.03	50.03.0350	J112	J-FET	Sx
.04	50.03.0350	J112	J-FET	Sx
.05	50.03.0436	BC 237	NPN	BC 547
.06	50.03.0515	BC 307	PNP	BC 557

IND	DATE	NAME
IR		IR INT. RECTIFER
S16		S16 SEMI-CONDUCTORS
Sx		Sx SILICONIX

STUDER AUXILIAR UNIT | 1.912.310.00 | page 2 of 6
13046510

IND POS NO	PART NO	VALUE	SPECIFICATIONS/EQUIVALENT	MFR
Q_07	50.03.0436	BC 237	NPN	BC 547
.08	50.03.0515	BC 307	PNP	BC 557
.09	50.03.0515	BD136-6	PNP	
.10	50.03.0436	BC 237	NPN	BC 547
.12	50.03.0515	BC 307	PNP	BC 557
.13	50.03.0436	BC 237	NPN	BC 547
.14	50.03.0515	BC 307	PNP	BC 557
.15	50.03.0510	BD136-6	PNP	
.16	50.03.0436	BC 237	NPN	BC 547
.17	50.03.0350	J112	J-FET	Sx
.18	50.03.0350	J112	J-FET	Sx
.19	50.03.0350	J112	J-FET	Sx
.20	50.03.0436	BC 237	NPN	BC 547
.21	50.03.0515	BC 307	PNP	BC 557
.22	50.03.0350	J112	J-FET	Sx
R_01	57.11.4163	10 k		MF
.02				
.03	57.11.4222	2.2 k	2%	
.04	57.11.4473	4.7 k		
.05	57.11.4223	2.2 k		
.06	57.11.4473	4.7 k		
.07	57.11.6106	10 M		
.08	57.11.4104	100 k		
.09	57.11.4474	4.7 k		
.10		2*4.7 k	ON-OFF SW LEFT	St
.11	1.912.001.52	-106		

IND	DATE	NAME
MF		MF METAL FILM
Sx		Sx SILICONIX
St		St STUDER

STUDER AUXILIAR UNIT | 1.912.310.00 | page 3 of 6
13046510

IND POS NO	PART NO	VALUE	SPECIFICATIONS/EQUIVALENT	MFR
R_40				
41	1.912.001.53	4*4.7 k	ON-OFF SW LEFT	St
510		-106		
511				
.12	57.11.4392	3.9 k		
.13	57.11.4394	390		
.14	57.11.4392	3.9 k		
.15	57.11.4474	4.70 k		
.16	57.11.4392	3.9 k		
.17	57.11.4682	6.8 k		
.18	57.11.4223	2.2 k		
.19	57.11.6106	10 M		
.20	57.11.6106	10 M		
.21	1.912.001.24	10k+106		
421		2*4.0k		
521	012.001.34	+106		
.22	57.11.4223	2.2 k		
.23	57.11.4222	2.2 k		
.24	57.11.4104	100 k		
.25	58.01.7103	10 k	TRIM	
.26	57.11.4452	4.5 k		
.27	57.11.3621	620	2%	
.28	57.11.3504	300	2%	
.29	57.11.3152	4.5 k	1%	
.30	57.11.3102	1.0 k	1%	
.31	57.11.3152	4.5 k	1%	
.32	57.11.4103	10 k		
.33	57.11.4103	10 k		
.34	57.11.4102	1 k		
.35	57.11.4102	1 k		

IND	DATE	NAME
St		St STUDER

STUDER AUXILIAR UNIT | 1.912.310.00 | page 4 of 6
13046510

IND POS NO	PART NO	VALUE	SPECIFICATIONS/EQUIVALENT	MFR
R_36	57.11.3811	510	1%	
.37	57.11.4479	4.7		
.38	57.11.4479	4.7		
.39	57.11.4120	42		
40	58.01.9204	220	TRIM	
.41	57.11.3152	4.5 k	1%	
.42	57.11.4103	10 k		
.43	57.11.4103	10 k		
.44	57.11.4102	1 k		
.45	57.11.4102	1 k		
.46	57.11.3152	4.5 k	1%	
.47	57.11.4479	4.7		
.48	57.11.4479	4.7		
.49				
.50	57.11.4151	150		
.51	57.09.0209	5.6	PTC	
.52	57.09.0209	5.6	PTC	
.53	57.11.4103	10 k		
.54	57.11.4103	10 k		
.55	57.11.6106	10 M		
.56	57.11.4103	10 k		
.57	57.11.4103	10 k		
.58	57.11.6106	10 M		
.59	57.11.4103	10 k		
.60	57.11.6106	10 M		
.61	57.11.4104	100 k		
.62	57.11.4104	100 k		
.63	57.11.4822	82 k		
.64	57.11.4473	4.7 k		
.65	57.11.4391	390		

IND	DATE	NAME
Ph		Ph PHILIPS

STUDER AUXILIAR UNIT | 1.912.310.00 | page 5 of 6
13046510

IND POS NO	PART NO	VALUE	SPECIFICATIONS/EQUIVALENT	MFR
R_64	57.11.4104	100 k		
.67	57.11.4105	1 M		
.68	57.11.4104	100 k		
.69	57.09.0209	5.6	PTC	Ph
.70	57.11.4104	100 k		
.71	57.11.6106	10 M		
.72	57.11.4222	2.2 k		
.73	57.11.4392	3.9 k		
.74	57.11.4104	100 k		
.75	57.11.4270	27		
.76	57.09.0209	5.6	PTC	Ph
S_01		1p ON	COMBINED WITH R10/R11	
.02	55.15.0003	2p	PUSHBUTTON SWITCH	
.03	55.03.0303		KNOB RED INDIC	
.04	55.15.0003	2p	PUSHBUTTON SWITCH	
.05	55.15.0004	4p	PUSHBUTTON SWITCH	
.06	55.15.0106		KNOB GRV/RED	
S_04	55.15.0003	2p	PUSHBUTTON SWITCH	
.07	55.15.0107		KNOB GRV/GRV	
T_01	1.022.353.00	1:1.25	LINE OUT TRAFO	
XIC	53.03.0166	8p	IC SOCKET	
	53.03.0166	16p	IC SOCKET	
XLED	54.01.0219			

IND	DATE	NAME
Ph		Ph PHILIPS

STUDER AUXILIAR UNIT | 1.912.310.00 | page 6 of 6
13046510

AUX Line Amplifier Board 1.912.311

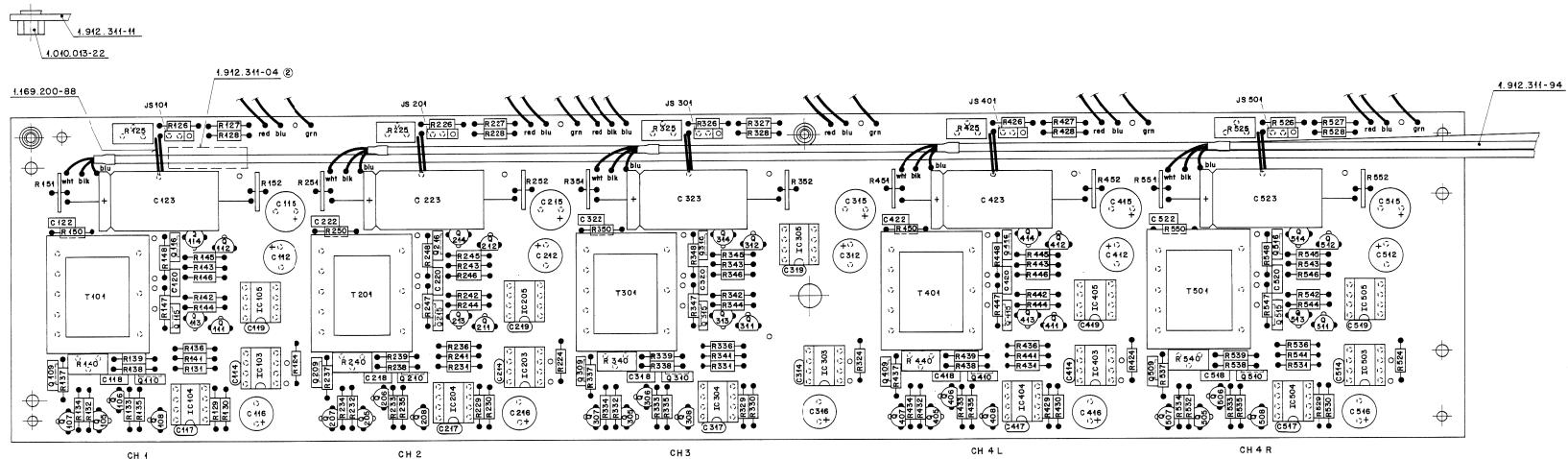

C 123 / C 223 / C 323 / C 423 / C 523
 verklebt nach BV 640 ③

Norm-Nr.:	Datum:	19.11.86	④
U.Nr. Bes.:	U.Nr. Bes.:	26.5.86 A. Ho	③
Abmessung:	Abmessung:	307.84 A.Ho	①
Zugehörige Unterlagen:	Freiweisbestanz:	Multisab:	②
PL 1.912.310		2.1	
Erstellt für:	Erstellt durch:	Kopie Nr.:	
STUDER RESENDORF ZÜRICH		Aux Line Amp Board	1.912.311-00

Studiomonitor- und Kommando-Einheit

Studiomonitor

Gegenseitig auslösende Drucktasten erlauben die Wahl zwischen sechs verschiedenen Quellen, die ins Studio eingespielt werden können. Die Abhörlautstärke wird über VCA gesteuert.

Die Studio-Lautstärke kann wahlweise durch das eingebaute Potentiometer oder durch eine von aussen kommende Steuerspannung eingestellt werden. Bei offenen Mikrofonreglern werden die Studiolautsprecher abgeschaltet. Der getrennte Kopfhörerausgang bleibt dabei eingeschaltet. Falls trotz offenen Mikrofonreglern Lautsprechereinspielen gewünscht wird, ist die Taste REIN zu drücken.

Talk Back Send

**TB STUDIO
TB SPEAKER**

Gegensprechen ins Studio ist über zwei Wege möglich: über die Einspiellautsprecher über eine im Sprechertisch oder im Dirigentenpult eingebaute Sprechstelle.

Die Taste SLATE schaltet das Kommandosignal auf die Summensammelschienen. Über fünf weitere Tasten kann Verbindung zu gleichwertigen Gegensprechstellen aufgenommen werden. Das von diesen Stellen kommende Antwortsignal wird über den TB/PFL-Lautsprecher wiedergegeben.

PFL / P.SOLO

In der Studiomonitor- und Kommando-Einheit sind auch die Sammelschienenverstärker von Vorhören (PFL) und Abhören nach Panoramapotiometer (P.SOLO) sowie der dazugehörige Lautstärkereglер und eine Kopfhörerbuchse untergebracht. Bei eingestecktem Kopfhörer wird der Vorhörlautsprecher unterbrochen.

Mit der Taste PFL/P.SOLO TO MONITOR wird der Vorhörlautsprecher ebenfalls unterbrochen. Sobald eine oder mehrere PFL- und P.SOLO Tasten gedrückt sind, wird automatisch das Monitor-signal unterbrochen und an seiner Stelle das gewählte PFL- oder P.SOLO-Signal auf die Abhörlautsprecher geschaltet. Dies ermöglicht, eine beliebige Gruppe von Eingangskanälen mit der richtigen, am Panoramapotiometer eingestellten Stereo-balance abzuhören. Die laufende Aufnahme oder Sendung wird dabei nicht beeinflusst. Sind alle ange-wählten PFL/P.SOLO Tasten durch nochmaliges Drücken wieder ausgeschaltet, oder werden diese durch Betätigung der RESET-Taste auf dem Signalisations-einschub zurückgestellt, so wird wieder das normale Monitor-signal hörbar.

(Siehe auch Blockdiagramm PFL-System)

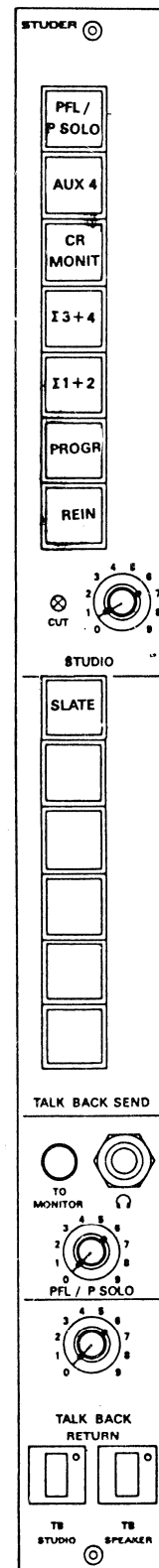

STUDIO MONITOR + TALK BACK

Studio monitor and talk back unit

Studio monitoring

With the aid of interlocking push buttons, six different sources can be fed back to the studio. The monitoring volume is controlled via VCAs.

The studio volume can either be adjusted with the built-in potentiometer or with an external control voltage. With open microphone channels the studio speakers are muted while the separate headphones output remains active. If the speakers are to be reinjected though the microphone controls are open, the REIN button must be pressed.

Talk back send

**TB STUDIO
TB SPEAKER**

Two methods are available for talking back to the studio:

via the talk back speakers
via a loudspeaker built into the announcer's or the conductor's desk.

The SLATE key connects the talk back signal to the bus. Five additional keys are available for communicating with similarly equipped talk back stations. The answering signal is reproduced by the TB/PFL speaker.

PFL / P.SOLO

The bus amplifiers of pre-fader listening (PFL) and monitoring after the panorama potentiometer (positional solo) as well as the corresponding volume control and headphones socket are also included in the studio monitor and talk back unit. When the headphones jack is inserted, the PFL speaker is muted.

With the PFL/P.SOLO TO MONITOR button the PFL speaker is also muted. As soon as one or more PFL- and P.SOLO buttons have been pressed, the monitor signal is automatically disabled and the selected PFL or P.SOLO signal is connected to the monitor speakers. In this manner it is possible to monitor any group of input channels with the true stereo balance as adjusted with the panorama potentiometer.

A recording or broadcast in progress will not be affected. If all selected PFL/P.SOLO buttons have been reset by pressing the RESET button on the signalling module, the normal monitor signal can be heard.

(Also refer to block diagram PFL system)

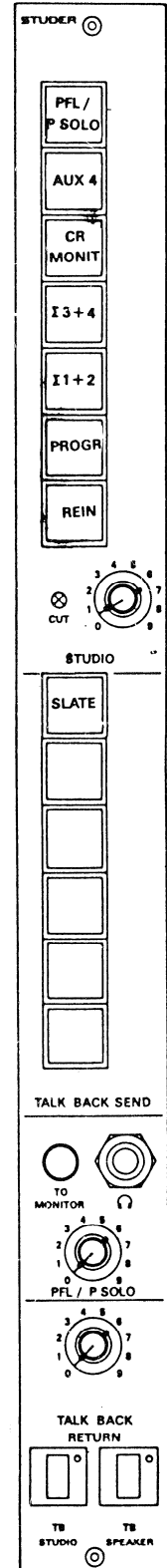

Blockdiagramm / Block diagram

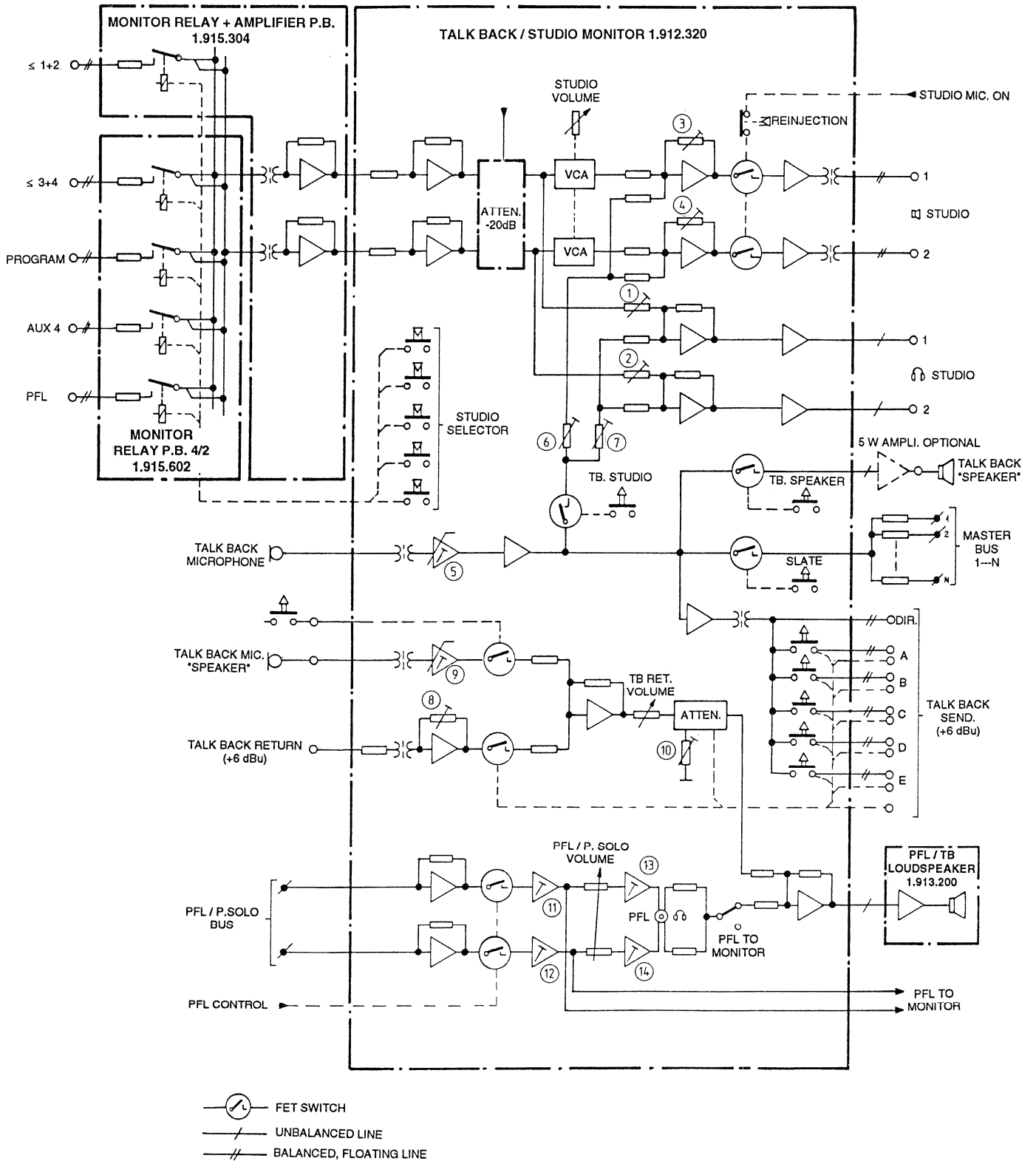

STUDIO MONITOR + TALK BACK

Abgleichelemente / Alignment Elements

Die Nummern beziehen sich auf das Blockdiagramm.

1	Ausgangspegel Studio-Kopfhörer, links,	R7
2	Ausgangspegel Studio-Kopfhörer, rechts	R28
3	Pegel Studioausgang, links	R11
4	Pegel Studioausgang, rechts	R32
5	Eingangspegel talk back mikro.	R99
6	Talk Back Pegel Studiolausprecher	R59
7	Talk Back Pegel Studiokopfhörer	R61
8	Talk Back Return Pegel (Leitungseingang)	R48
9	Talk Back Return Pegel 'Speaker mikro.'	R23
10	Dämpfung Talk Back Return Pegel	R39
11	Pegel PFL/P SOLO links	R67
12	Pegel PFL/P SOLO rechts	R70
13	Pegel PFL/P SOLO Kopfhörer links	R79
14	Pegel PFL/P SOLO Kopfhörer rechts	R87

The numbers relate to the block diagram.

1	Input level to headphones studio, left	R7
2	Input level to headphones studio, right	R28
3	Studio output level, left	R11
4	Studio output level, right	R32
5	Input level talk back mic.	R99
6	Talk back level studio speaker	R59
7	Talk back level studio headphones	R61
8	Talk back return level (line input)	R48
9	Talk back return level speaker mic	R23
10	Attenuation talk back return level	R39
11	Level PFL/P SOLO left	R67
12	Level PFL/P SOLO right	R70
13	Level PFL/P SOLO headphones left	R79
14	Level PFL/P SOLO headphones right	R87

Talk Back / Studio Monitor 1.912.320 SC 1 of 3

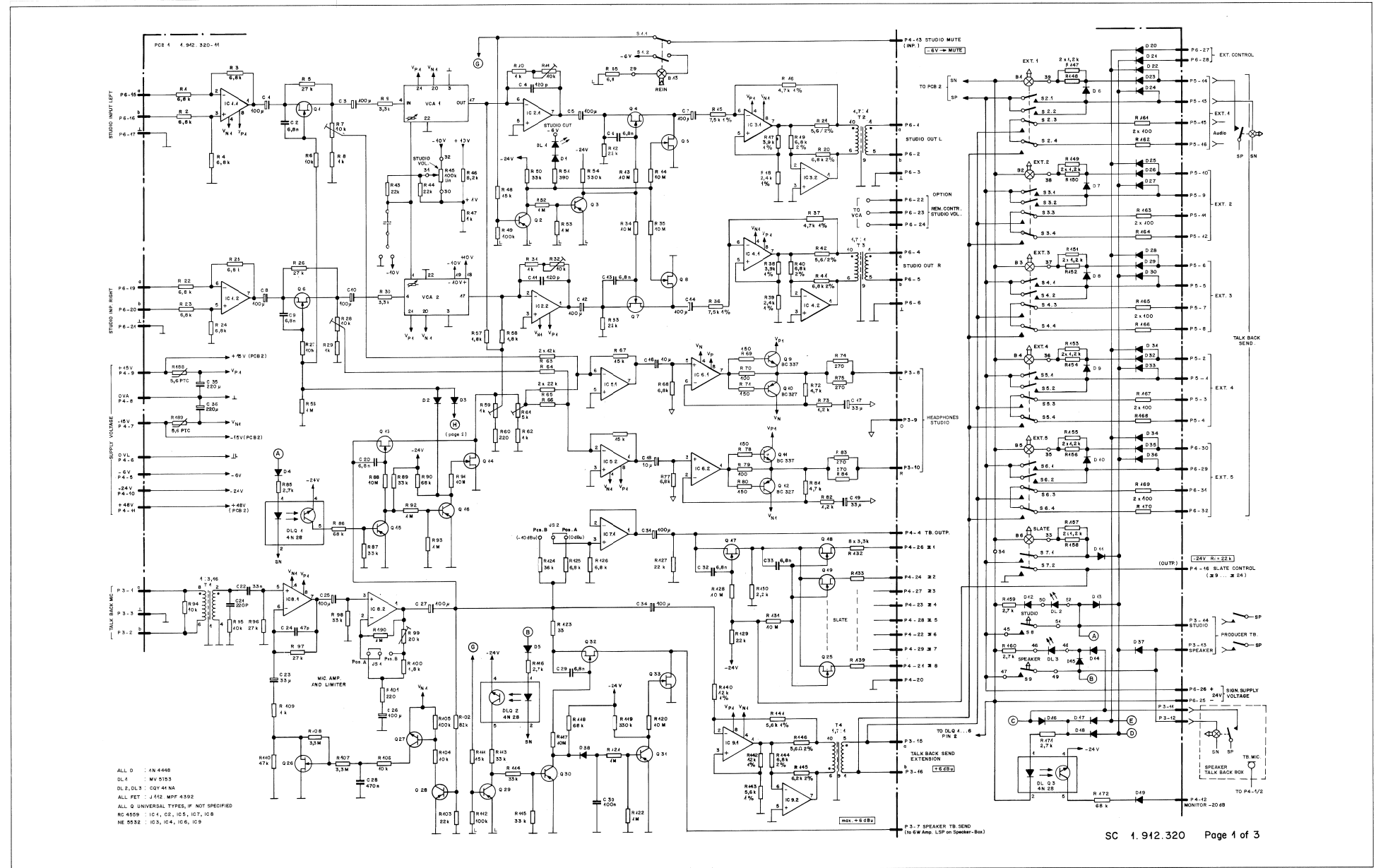

Talk Back / Studio Monitor 1.912.320 SC 2 of 3

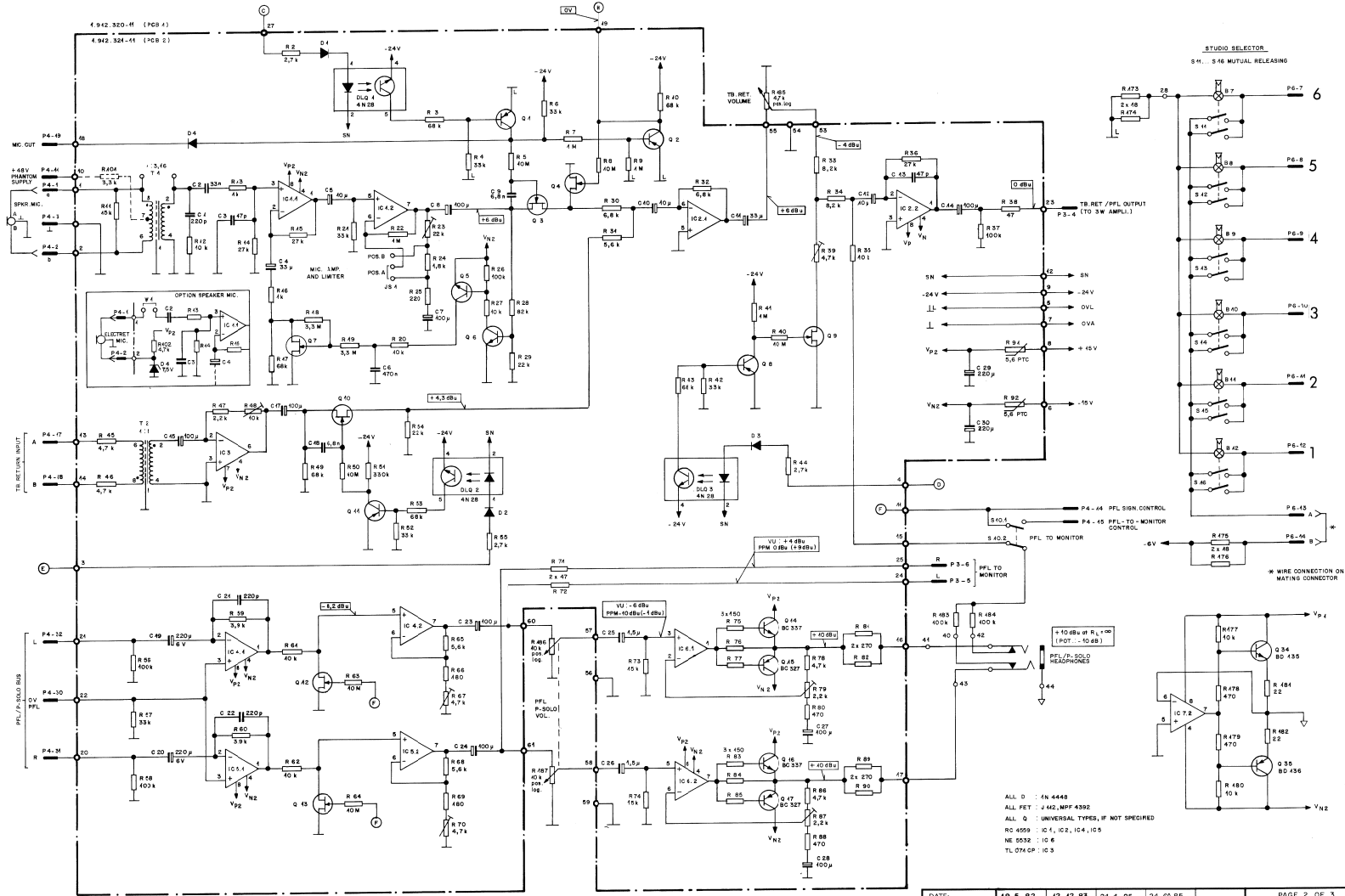

ALL D : 4N 4448
 ALL FET : 442, MPF 4392
 ALL Q : UNIVERSAL TYPES, IF NOT SPECIFIED
 RC 8055 : 24, 102, 104, 105
 NE 5552 : 10 G
 TL 074 GP : 10 C

DATE:	49.5.82	42.42.83	24.4.85	24.09.85	PAGE 2 OF 3
SIGN:	<i>My</i>	<i>ul</i>	<i>ul</i>	<i>ul</i>	
STUDER REGENSDORF ZÜRICH	TALK BACK / STUDIO MONITOR				SC 1.912.320

Talk Back / Studio Monitor 1.912.320 SC 3 of 3

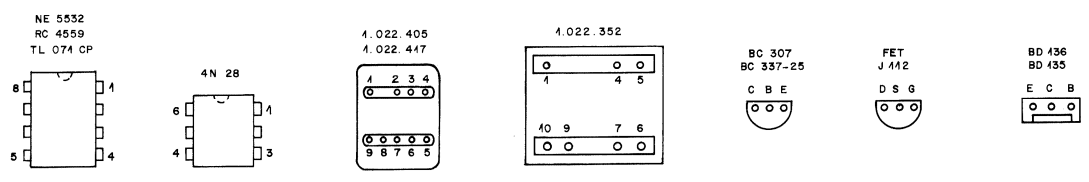
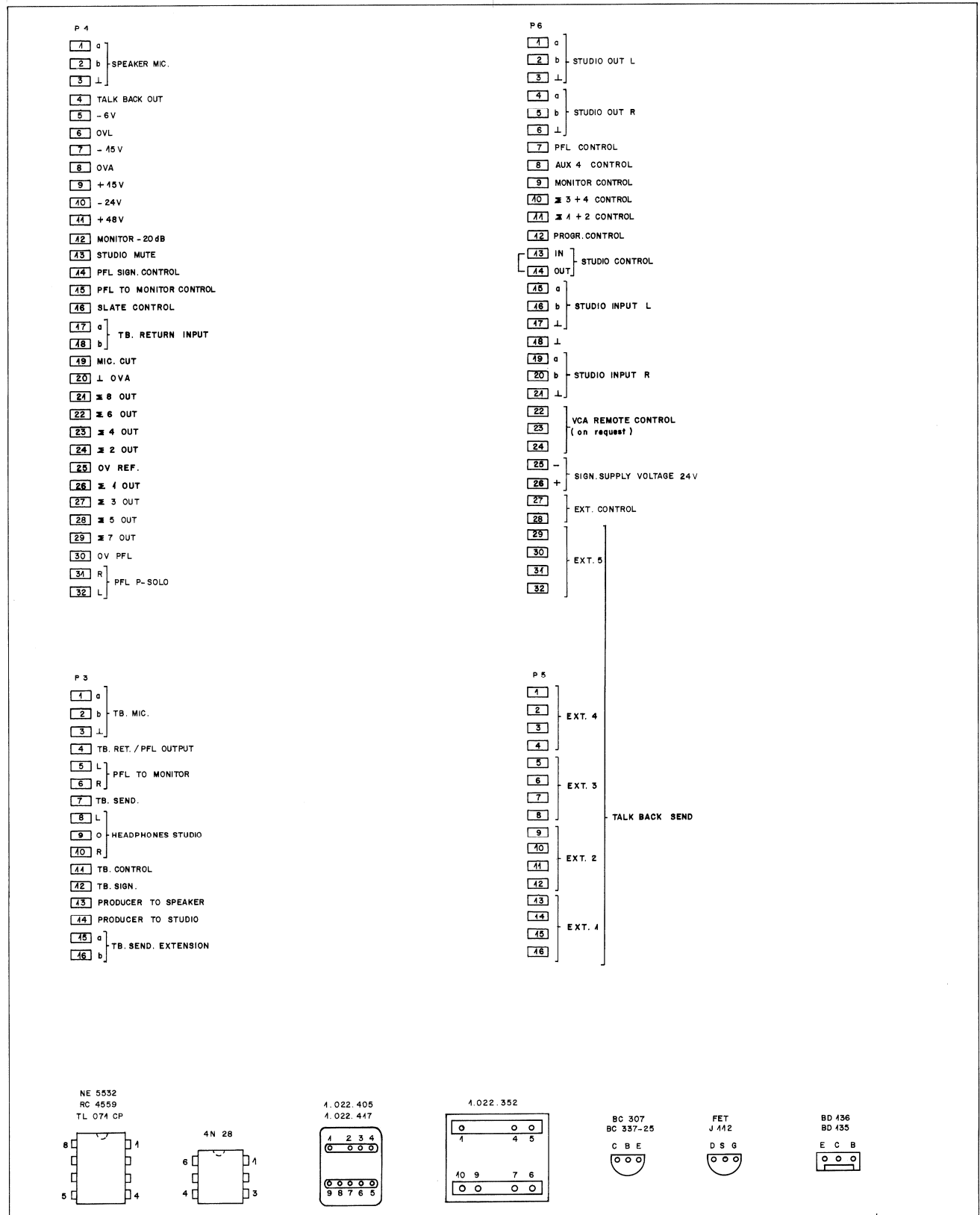

Talk Back / Studio Monitor 1.912.320

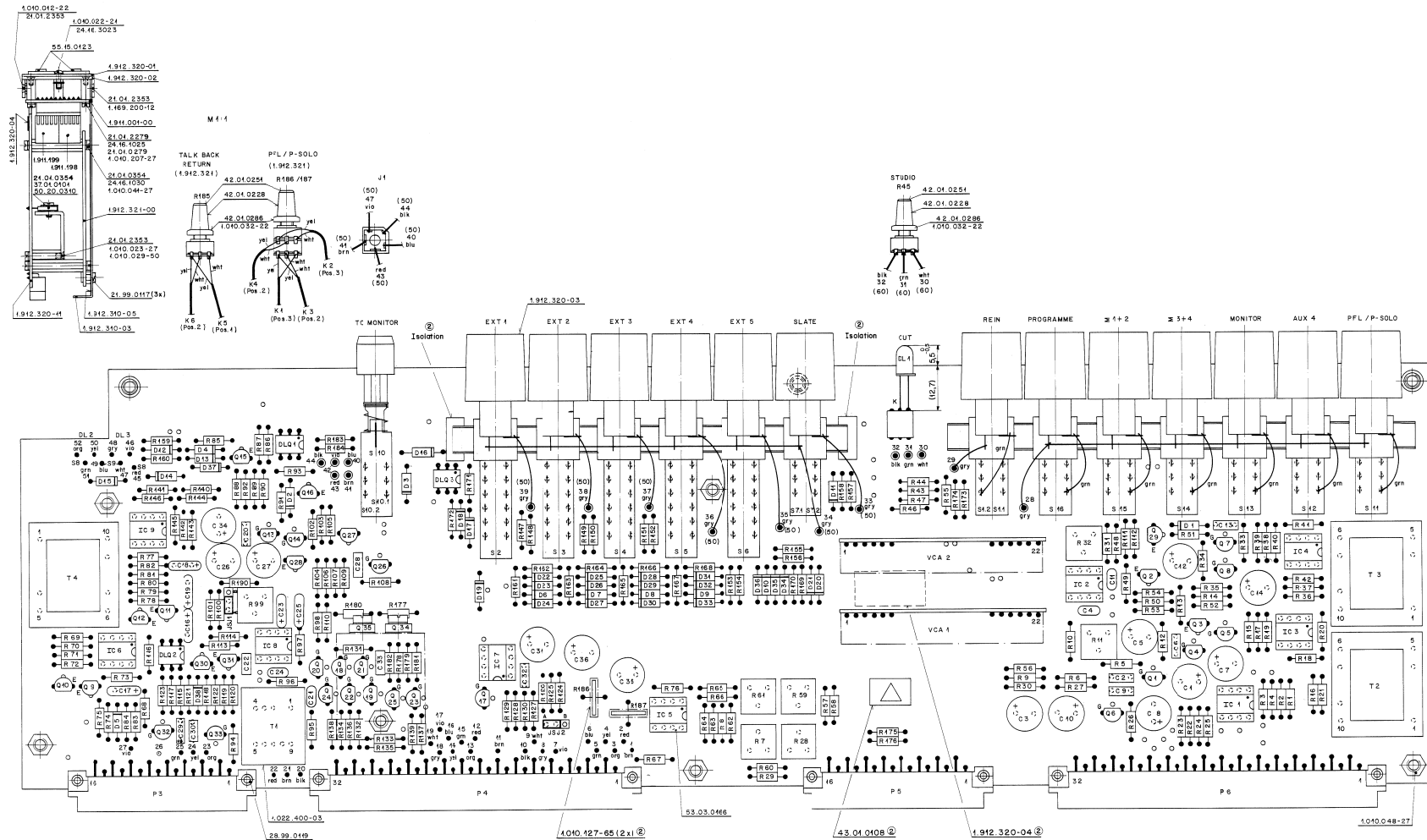

(---) Länge der Litzen
 (Pos.) = Pos. Nr. von Kl. 1.912.320-94

② Q34, Q35
 Montage und Montagematerial
 nach BV632

Werkstoff	Norm-Nr.:	Stück	26.5.86	A.Ho	✓	②
	DIN-Nr.:	Übersicht:	12.12.83	A.Ho	✓	②
	Abmessung:	Ben:	20.10.82	A.Ho	✓	②
	Zugehörige Zeichnungen:	Früherbestimmung:	Maßstab:	Datum:	Gez.:	Gepr.:
	PL, LL, KL	is	1:4 ; 2:1			
Ersetzt für:	Erwartet durch:	Kopie Nr.:				
STÜDER HÖRGERÄTEWERK ZÜRICH		Talk Back / Studio Monitor ESE		1.912.320-00		

Talk Back / Studio Monitor 1.912.320

Table with columns: INDI POS NO, PART NO, VALUE, SPECIFICATIONS/EQUIVALENT, MFR. Rows include components like 54.02.044L, 58.22.440A, 59.06.0682, etc.

Table with columns: INDI, DATE, NAME. Includes notes like CER Ceramic, EL Electrolytic, PE Polyester.

Table with columns: INDI POS NO, PART NO, VALUE, SPECIFICATIONS/EQUIVALENT, MFR. Rows include 59.06.0682, 59.22.440A, 59.22.440B, etc.

Table with columns: INDI, DATE, NAME. Includes notes like CM Chicago Mn., Ex Exar, M Motorola.

Table with columns: INDI POS NO, PART NO, VALUE, SPECIFICATIONS/EQUIVALENT, MFR. Rows include 50.03.0350, 50.03.0545, 50.03.0350, etc.

Table with columns: INDI, DATE, NAME. Includes notes like M Motorola, N National, S Siliconix.

Table with columns: INDI POS NO, PART NO, VALUE, SPECIFICATIONS/EQUIVALENT, MFR. Rows include 50.03.0545, 50.03.0350, 50.03.0350, etc.

Table with columns: INDI, DATE, NAME. Includes notes like M Motorola, Ms Motorola, Rv Raytheon.

Table with columns: INDI POS NO, PART NO, VALUE, SPECIFICATIONS/EQUIVALENT, MFR. Rows include 57.14.4682, 57.14.4273, 57.14.4273, etc.

Table with columns: INDI, DATE, NAME. Includes notes like M Motorola, N National, S Siliconix.

Table with columns: INDI POS NO, PART NO, VALUE, SPECIFICATIONS/EQUIVALENT, MFR. Rows include 57.14.4682, 57.14.4273, 57.14.4273, etc.

Table with columns: INDI, DATE, NAME. Includes notes like M Motorola, N National, S Siliconix.

Table with columns: INDI POS NO, PART NO, VALUE, SPECIFICATIONS/EQUIVALENT, MFR. Rows include 57.14.4272, 57.14.4683, 57.14.4333, etc.

Table with columns: INDI, DATE, NAME. Includes notes like M Motorola, N National, S Siliconix.

Table with columns: INDI POS NO, PART NO, VALUE, SPECIFICATIONS/EQUIVALENT, MFR. Rows include 57.14.4333, 57.14.4272, 57.14.4272, etc.

Table with columns: INDI, DATE, NAME. Includes notes like M Motorola, N National, S Siliconix.

Talk Back / PFL Amplifier 1.912.321

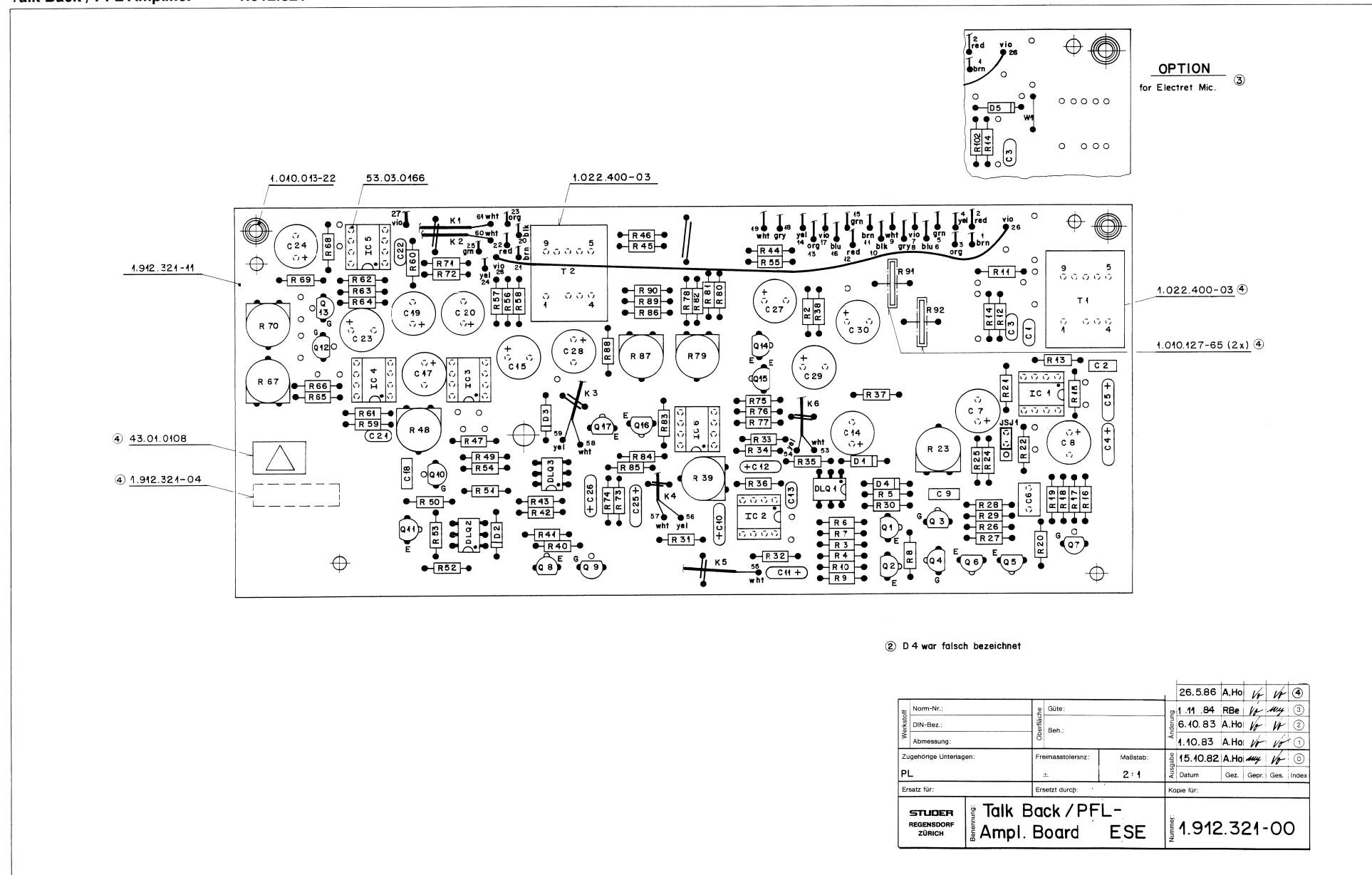

② D 4 war falsch bezeichnet

Norm-Nr.:		Güte:		26.5.86 A.Ho <i>W</i> ④	
DIN-Bez.:		Ben.:		1.11.84 RBe <i>W</i> ③	
Abmessung:		Anforderung:		6.10.83 A.Ho <i>W</i> ②	
Zugehörige Unterlagen:		Freimasstoleranz:		1.10.83 A.Ho <i>W</i> ①	
PL		Maßstab:		15.10.82 A.Ho <i>W</i> ①	
Ersatz für:		Ersetzt durch:		Datum Gez. Gepr. Ges. Index	
STUDER REGENSDORF ZÜRICH		Benennung: Talk Back / PFL- Ampl. Board ESE		Nummer: 1.912.321-00	

Talk Back / PFL Amplifier 1.912.321

IND POS NO	PART NO	VALUE	SPECIFICATIONS/EQUIVALENT	MFR
C 1	59.34.422.4	220µF	CER 5%	
C 2	59.06.033.3	33µF	PE 40%	
C 3	59.34.247.0	47µF	CER 5%	
C 4	59.26.433.0	33µF	SAL 40V	
C 5	59.26.240.0	40µF	SAL 46V	
C 6	59.06.047.4	470µF	PE 40%	
C 7	59.22.440.4	100µF	EL 46V	
C 8	59.22.440.4	100µF	EL 46V	
C 9	59.06.068.2	68µF	PE 40%	
C 10	59.26.240.0	40µF	SAL 46V	
C 11	59.26.433.0	33µF	SAL 40V	
C 12	59.22.641.00	40µF	EL 46V	
C 13	59.34.247.0	47µF	CER 5%	
C 14	59.22.440.4	100µF	EL 46V	
C 15	59.22.440.4	100µF	EL 46V	
C 17	59.22.440.4	100µF	EL 46V	
C 18	59.06.068.2	68µF	PE 40%	
C 19	59.22.222.4	220µF	EL 6V	
C 20	59.22.222.4	220µF	EL 6V	
C 21	59.34.422.4	220µF	CER 5%	
C 22	59.34.422.4	220µF	CER 5%	
C 23	59.22.440.4	100µF	EL 46V	
C 24	59.22.440.4	100µF	EL 46V	
C 25	59.26.515.9	15µF	SAL 25V	
C 26	59.26.515.9	15µF	SAL 25V	
C 27	59.22.440.4	100µF	EL 46V	
C 28	59.22.440.4	100µF	EL 46V	
C 29	59.22.422.4	220µF	EL 46V	
C 30	59.22.422.4	220µF	EL 46V	

IND	DATE	NAME
Q		CER Ceramic
E		EL Electrolytic
P	19-04-85	PE Polyester
S	25-2-85	SAL Solid Aluminium Lacquered
C	05-04-82	

STUDER Talk Back/PFL-Ampl. Board PL 1.912.321 PAGE 4 OF 6

IND POS NO	PART NO	VALUE	SPECIFICATIONS/EQUIVALENT	MFR
D 1	50.04.012.5	1N4448	or equivalent	any
D 2	50.04.012.5	1N4448	or equivalent	any
D 3	50.04.012.5	1N4448	or equivalent	any
D 4	50.04.012.5	1N4448	or equivalent	any
D 10	50.89.042.6	4N26	4N28	M, TI
D 10 Q	50.89.042.6	4N26	4N28	M, TI
D 10 S	50.89.042.6	4N26	4N28	M, TI
IC 1	50.08.0107	RC4558		Ro, TI
IC 2	50.08.0107	RC4558		Ro, TI
IC 3	50.08.0103	TL034CP	LF354N	TI, N
IC 4	50.08.0107	RC4558		Ro, TI
IC 5	50.09.0407	RC4559		Ro, TI
IC 6	50.08.0405	NE5532N	XR 5532N	Si, Ex
J5.1	54.04.022.1		Jumper jack	
Q 1	50.03.054.5	P-N-P *		any
Q 2	50.03.054.5	P-N-P *		any
Q 3	50.03.015.0	J-N-FET	JM2, MPF 4392	Si, N,M
Q 4	50.03.015.0	J-N-FET	JM2, MPF 4392	Si, N,M
Q 5	50.03.015.0	J-N-FET *		any
Q 6	50.03.054.5	P-N-P *		any
Q 7	50.03.015.0	J-N-FET	JM2, MPF 4392	Si, N,M
Q 8	50.03.054.5	P-N-P *		any
Q 9	50.03.015.0	J-N-FET	JM2, MPF 4392	Si, N,M
Q 10	50.03.015.0	J-N-FET	JM2, MPF 4392	Si, N,M
Q 11	50.03.054.5	P-N-P *		any
Q 12	50.03.015.0	J-N-FET	JM2, MPF 4392	Si, N,M
Q 13	50.03.015.0	J-N-FET	JM2, MPF 4392	Si, N,M

IND	DATE	NAME
E		Ex Exar
M		M Motorola
N		N National
P	25-2-85	PE Polyester
S	05-04-82	S Solid

STUDER Talk Back/PFL-Ampl. Board PL 1.912.321 PAGE 2 OF 6

IND POS NO	PART NO	VALUE	SPECIFICATIONS/EQUIVALENT	MFR
R51	57.11.410.4	100k		
R52	57.11.433.3	33k		
R58	57.11.410.4	100k		
R59	57.11.438.2	3.8k		
R60	57.11.438.2	3.8k		
R61	57.11.410.3	10k		
R62	57.11.410.3	10k		
R63	57.11.610.6	10M		
R64	57.11.610.6	10M		
R65	57.11.456.2	56k		
R66	57.11.448.4	480		
R67	58.02.547.2	47k	Trim-Pot.	
R68	57.11.456.2	56k		
R69	57.11.448.4	480		
R70	58.02.547.2	47k	Trim-Pot.	
R71	57.11.410.7	47		
R72	57.11.410.7	47		
R73	57.11.448.3	48		
R74	57.11.448.3	48k		
R75	57.11.448.4	480		
R76	57.11.448.4	480		
R77	57.11.448.4	480		
R78	57.11.448.2	47k		
R79	58.02.522.2	22k	Trim-Pot	
R80	57.11.447.4	470		
R81	57.11.422.4	220		
R82	57.11.422.4	220		
R83	57.11.448.4	480		
R84	57.11.448.4	480		
R85	57.11.448.4	480		

IND	DATE	NAME
Q		Q
E		E
P	19-04-85	PE Polyester
S	25-02-85	S
C	05-04-82	C

STUDER Talk Back/PFL-Ampl. Board PL 1.912.321 PAGE 5 OF 6

IND POS NO	PART NO	VALUE	SPECIFICATIONS/EQUIVALENT	MFR
R86	57.11.447.2	47k		
R87	58.02.522.2	22k	Trim-Pot.	
R88	57.11.447.4	470		
R89	57.11.427.4	270		
R90	57.11.427.4	270		
R91	57.89.020.9	5.6	PTC Philips	
R92	57.89.020.9	5.6	PTC Philips	
T 1	1.022.447.00	1:3,46	Mic-Trafo	Studer
T 2	1.022.405.00	1:1	Input-Trafo	Studer
XIC	53.03.04.66		IC-socket, DIP 8 pins	
P	54.01.002.0		Plug for Jumper J5.1 / P5.1	

IND	DATE	NAME
Q		Q
E		E
P	19-04-85	PE Polyester
S	25-02-85	S
C	05-04-82	C

STUDER Talk Back/PFL-Ampl. Board PL 1.912.321 PAGE 6 OF 6

IND POS NO	PART NO	VALUE	SPECIFICATIONS/EQUIVALENT	MFR
R11	50.03.034.0	N-P-N	ic 800µA BC132-25 or equiv.	any
R15	50.03.034.0	P-N-P	ic 800µA BC132-25 or equiv.	any
R16	50.03.034.0	N-P-N	ic 800µA BC132-25 or equiv.	any
R17	50.03.034.0	P-N-P	ic 800µA BC132-25 or equiv.	any
R2	57.11.427.2	27k		
R3	57.11.468.3	68k		
R4	57.11.433.3	33k		
R5	57.11.610.6	10M		
R6	57.11.433.3	33k		
R7	57.11.441.05	4M		
R8	57.11.610.6	10M		
R9	57.11.441.05	4M		
R10	57.11.468.3	68k		
R11	57.11.448.3	48k		
R12	57.11.441.03	4k		
R13	57.11.441.02	4k		
R14	57.11.427.3	27k		
R15	57.11.427.3	27k		
R16	57.11.441.02	4k		
R17	57.11.468.3	68k		
R18	57.11.633.5	3.3M		
R19	57.11.633.5	3.3M		
R20	57.11.441.03	4k		
R21	57.11.433.3	33k		
R22	57.11.441.05	4M		
R23	58.02.522.3	22k	Trim-Pot.	
R24	57.11.448.2	48k		
R25	57.11.422.4	220		

IND	DATE	NAME
Q		Q
E		E
P	19-04-85	PE Polyester
S	25-02-85	S
C	05-04-82	C

STUDER Talk Back/PFL-Ampl. Board PL 1.912.321 PAGE 3 OF 6

IND POS NO	PART NO	VALUE	SPECIFICATIONS/EQUIVALENT	MFR
R26	57.11.410.4	100k		
R27	57.11.410.3	10k		
R28	57.11.438.2	3.8k		
R29	57.11.422.3	22k		
R30	57.11.448.2	48k		
R31	57.11.456.2	56k		
R32	57.11.448.2	48k		
R33	57.11.448.2	48k		
R34	57.11.482.2	82k		
R35	57.11.410.3	10k		
R36	57.11.427.3	27k		
R37	57.11.410.4	100k		
R38	57.11.447.0	47		
R39	58.02.547.2	47k	Trim-Pot	
R40	57.11.610.6	10M		
R41	57.11.441.05	4M		
R42	57.11.433.3	33k		
R43	57.11.448.3	48k		
R44	57.11.427.2	27k		
R45	57.11.447.2	47k		
R46	57.11.447.2	47k		
R47	57.11.422.2	22k		
R48	58.02.540.3	40k	Trim-Pot.	
R49	57.11.448.3	48k		
R50	57.11.610.6	10M		
R51	57.11.433.4	330k		
R52	57.11.433.3	33k		
R53	57.11.448.3	48k		
R54	57.11.422.3	22k		
R55	57.11.427.2	27k		

IND	DATE	NAME
Q		Q
E		E
P	19-04-85	PE Polyester
S	25-02-85	S
C	05-04-82	C

STUDER Talk Back/PFL-Ampl. Board PL 1.912.321 PAGE 4 OF 6

Kontrollraum Monitor

Über gegenseitig auslösende Drucktasten können 15 verschiedene Abhörquellen angewählt werden. Um einen optimalen Gleichlauf des Stereoabhörens zu garantieren, steuert das Lautstärkepotentiometer zwei VCA. Allfällige, durch den Raum oder die Lautsprecher hervorgerufene Lautstärkeunsymmetrie, kann durch das schaltbare Balance-Potentiometer ausgeglichen werden. Tasten für Lautsprecher- und Phasenvertauschung sowie die Mono-Taste helfen dem Tonmeister beim Qualitäts- und Kompatibilitätstest. Der Ausgang des Abhörzuges ist auf zwei Monitorlautsprecher umschaltbar. Mit der METER-Taste können die Aussteuerungsmesser 1 und 2 wahlweise an die Summenausgänge $\Sigma 1 + 2$ oder parallel zum Abhör Lautsprecher geschaltet werden.

Kopfhörerbuchsen (Impedanz 200 Ω) und Schalter zum Dämpfen (-20dB) bzw. Abschalten des Einschubes vervollständigen den Einschub.

METER: Pegelanzeige umschaltbar von der Summe auf den Kontrollraum Monitor.

Ø CH1: Kanalvertauschung am Lautsprecherausgang
Die Phase des linken Kanals wird um 180° gedreht

BALANCE IN: Das BALANCE Potentiometer wird eingeschaltet.
MONO: Die zwei Abhörkanäle werden als Monosumme auf beide Monitorlautsprecher geschaltet.

EXT-INT: Ausgang umschaltbar auf zwei Monitorsysteme.
VOLUME: Lautstärkeregler

MONITOR -20dB: Die Abhör lautstärke wird um 20dB abgesenkt. (auch von extern, z.B. durch Talk Back)

MONITOR OFF: Der Lautsprecherausgang wird abgeschaltet.

Speisung

	Leerlauf
+ 15 V	120mA
- 15 V	120mA
- 6 V	60...120mA
- 24 V	1mA

Mechanische Daten

Frontplatte	420 x 40mm
Tiefe	135mm
Gewicht	850 g

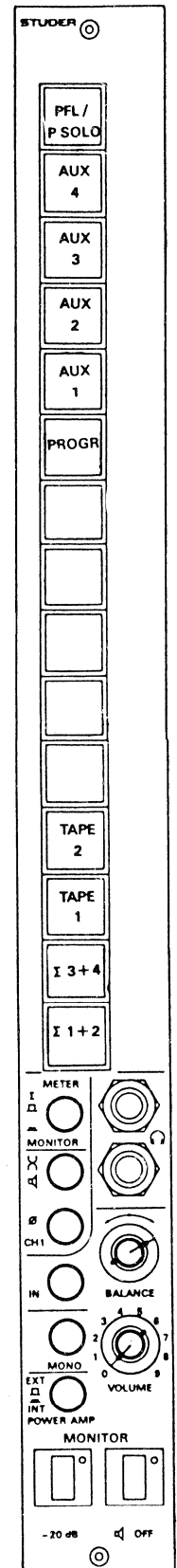

CR MONITOR

C.R. Monitor unit

Fifteen different monitoring sources can be selected with interlocking push buttons. In order to ensure optimum stereo tracking, the volume potentiometer controls VCAs. Any volume imbalance caused by the room acoustics or the speakers can be compensated by the switchable balance potentiometer. Buttons for speaker and phase transposition as well as the mono button are useful for the sound engineer during quality and compatibility tests. The output of the monitoring circuit can be switched between two monitor speakers. With the METER button the peak program meters 1 and 2 can selectively be connected to the master outputs 1 + 2 or in parallel to the monitoring speaker.

Headphones socket (impedance 200 Ω) and switch for muting or toning down (-20dB) the speakers are also included with this module.

METER: Instrument switchable from master to CR monitor.

: Left- and right-hand speaker outputs are transposed.

Ø CH1: The phase of the left-hand channel is inverted by 180°.

BALANCE IN: The BALANCE potentiometer is looped into the circuit.

MONO: Both monitor speakers reproduce a mono signal.

EXT-INT: Output switchable to a second monitor system.

VOLUME: Volume control

MONITOR -20dB: Level is attenuated by 20dB (also from external outputs, e.g. talk back path)

MONITOR OFF: The speaker output is switched off.

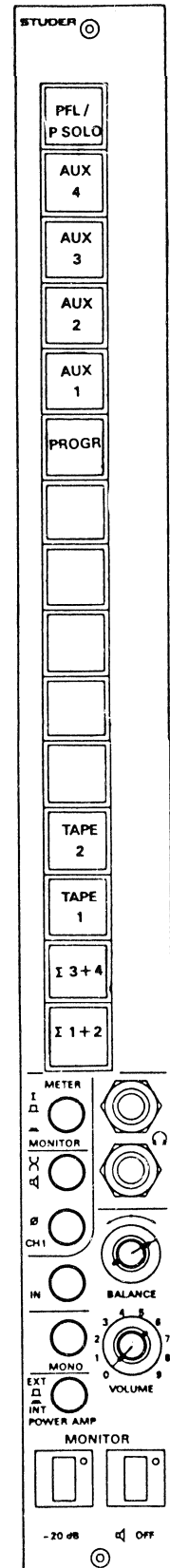

Power supply

	No load
+ 15 V	120mA
- 15 V	120mA
- 6 V	60...120mA
- 24 V	1mA

Physical data

Front panel	420 x 40mm
Depth	135mm
Weight	850 g

Blockdiagramm / Block diagram

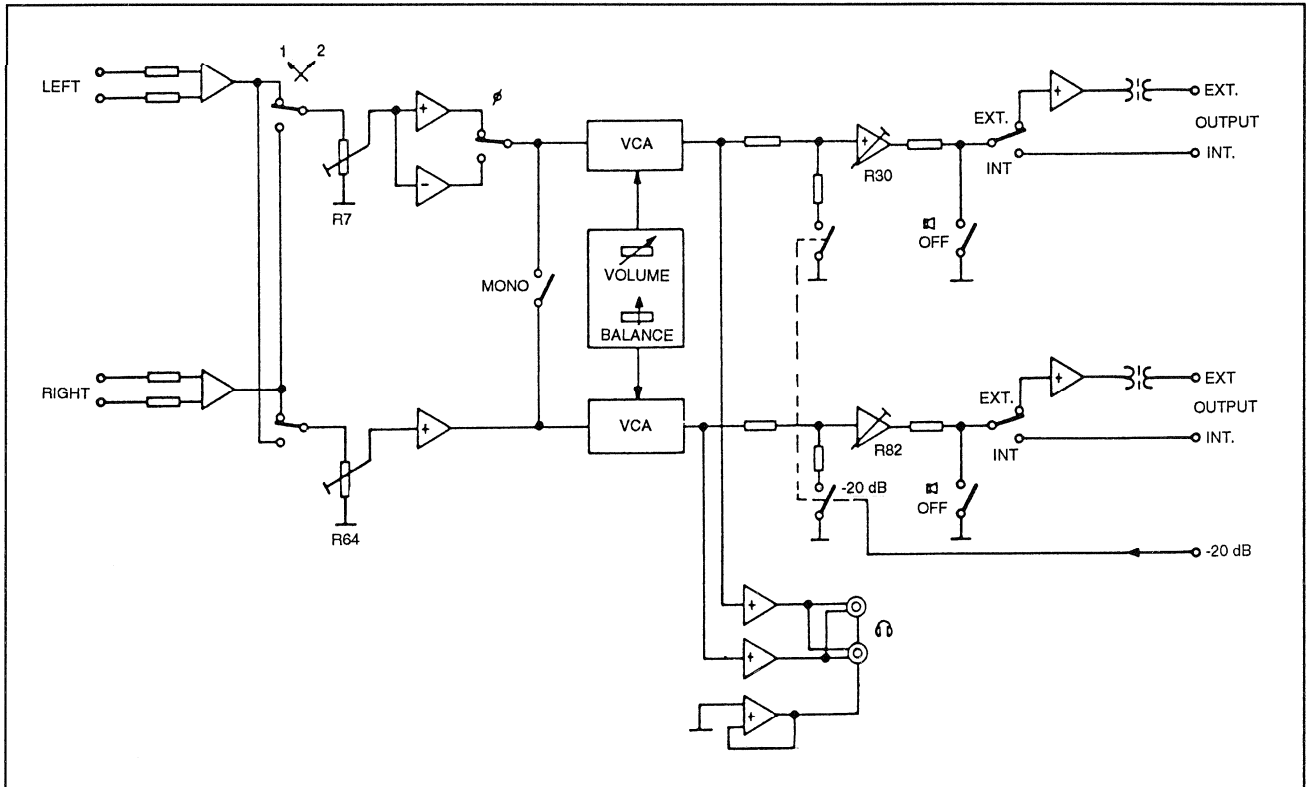

Control Room Monitor Unit 1.912.420

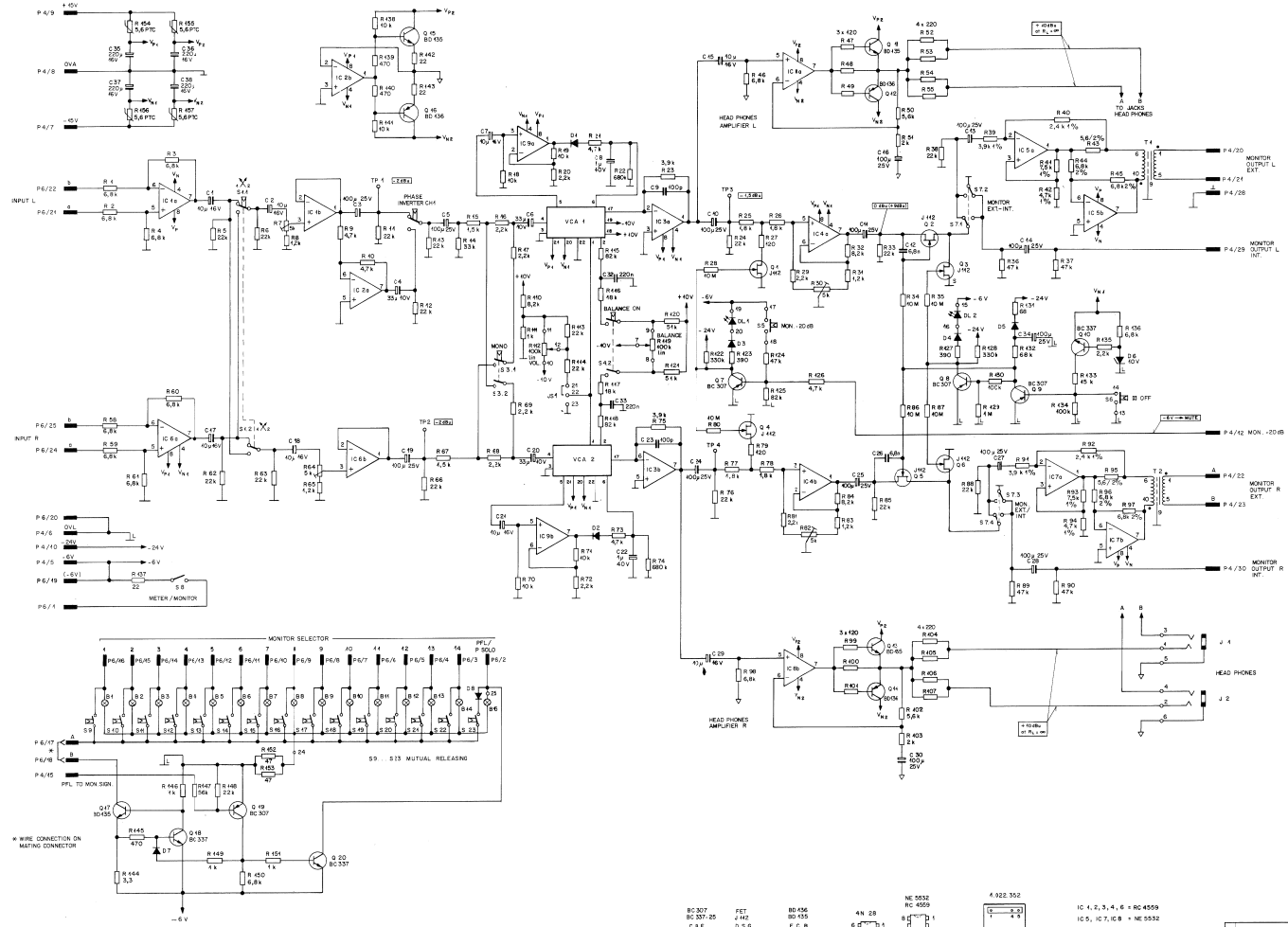

NE 5532 IC 4559
 BC 307 BC 307-25 PCT J 142
 C 3.6 C 3.6
 4N 20 5 2.2
 6 2.2 1
 5 2.2 1
 4 2.2 1
 3 2.2 1
 2 2.2 1
 1 2.2 1

4 322 352
 1 1.5
 2 1.5
 3 1.5
 4 1.5
 5 1.5
 6 1.5
 7 1.5
 8 1.5
 9 1.5
 10 1.5

IC 1, 2, 3, 4, 6 + IC 4559
 IC 5, IC 7, IC 8 + NE 5532
 D 1, 2, 3, 4, 5 + N 4448
 D 1, D 2 + CD 41MA

Norm-Nr.:	Date:				
Abmessung:	Beh.:	42 9 85	Si	W	
Suppl./Bsp. Übertragen:	Preisassistent:	Material:	8	40 1 82	Si
Erstellt von:	Erstellt durch:	Proje-Nr.:	000	000	000
STUDER RECHENBERG ZÜRICH		C.R. MONITOR UNIT		SC 1.912.420	

Control Room Monitor Unit 1.912.420

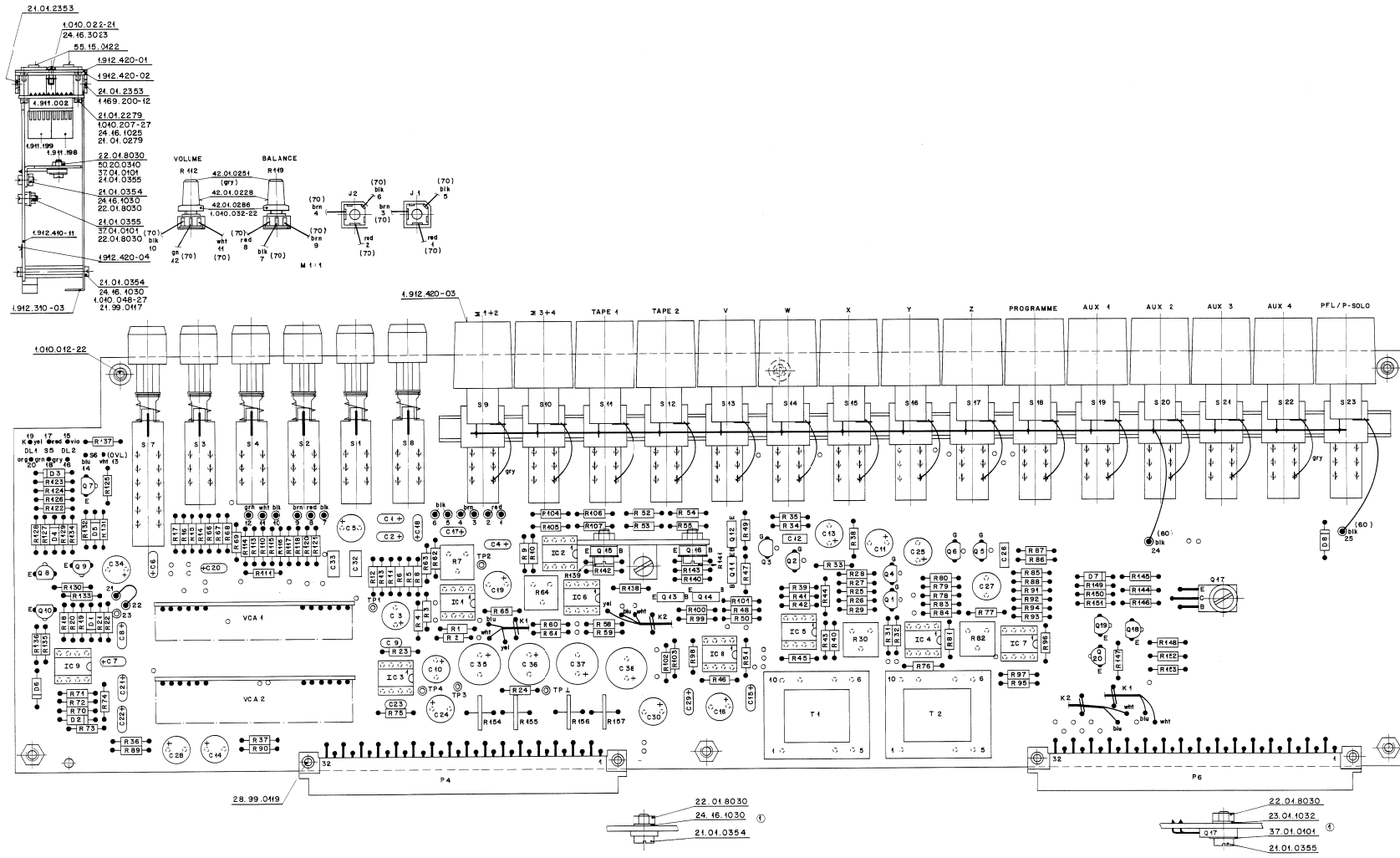

Norm-Nr.	Größe				
Drh-Bez.	Charakter				
Abmessung	Material	1,5.84	A.Hg		
Zugehörige Unterlagen	Freischnittzeichnung	Maßstab:	1:10 B2	A.Hg	
Erstellt für:	Erstellt durch:	Datum:	1.4.2.4	Gez.	Gez. (Name)
STUDER REGISCHOPF ZÜRICH		Cr. Monitor Unit 2CH		1.912.420-00	

Control Room Monitor Unit 1.912.420

IND	POS NO	PART NO	VALUE	SPECIFICATIONS/EQUIVALENT	MFR
		50.02.0404	10M	Lamp T4%	
C 1	50.26.4102	100uF	SAL 46 V		
C 2	50.26.4102	100uF	SAL 46 V		
C 3	50.22.5104	100uF	EL 25V		
C 4	50.26.4330	33uF	SAL 40V		
C 5	50.22.5104	100uF	EL 25V		
C 6	50.26.4330	33uF	SAL 40V		
C 7	50.26.2400	10uF	SAL 46V		
C 8	50.26.9409	1uF	SAL 40V		
C 9	50.34.4104	100pF	CER 5%		
C 10	50.22.5104	100uF	EL 25V		
C 11	50.22.5104	100uF	EL 25V		
C 12	50.06.0692	6.8pF	PE 40%		
C 13	50.22.5104	100uF	EL 25V		
C 14	50.22.5104	100uF	EL 25V		
C 15	50.26.2400	10uF	SAL 46V		
C 16	50.22.5104	100uF	EL 25V		
C 17	50.26.2400	10uF	SAL 46V		
C 18	50.26.2400	10uF	SAL 46V		
C 19	50.22.5104	100uF	EL 25V		
C 20	50.26.4330	33uF	SAL 40V		
C 21	50.26.2400	10uF	SAL 46V		
C 22	50.26.9409	1uF	SAL 40V		
C 23	50.34.4104	100pF	CER 5%		
C 24	50.22.5104	100uF	EL 25V		
C 25	50.22.5104	100uF	EL 25V		
C 26	50.06.0692	6.8pF	PE 40%		
C 27	50.22.5104	100uF	EL 25V		
C 28	50.22.5104	100uF	EL 25V		
C 29	50.26.2400	10uF	SAL 46 V		

IND	DATE	NAME	DESCRIPTION
①			EL ELECTROLYTIC
②			PE POLYESTER
③			CER CERAMIC
④			SAL SOLID ALUMINIUM LAQUERED
⑤			
⑥			
⑦			
⑧			
⑨			
⑩			
⑪			
⑫			
⑬			
⑭			
⑮			
⑯			
⑰			
⑱			
⑲			
⑳			
㉑			
㉒			
㉓			
㉔			
㉕			
㉖			
㉗			
㉘			
㉙			
㉚			
㉛			
㉜			
㉝			
㉞			
㉟			
㊱			
㊲			
㊳			
㊴			
㊵			
㊶			
㊷			
㊸			
㊹			
㊺			
㊻			
㊼			
㊽			
㊾			
㊿			
①	04-04-92	Any	
②			
③			
④			
⑤			
⑥			
⑦			
⑧			
⑨			
⑩			
⑪			
⑫			
⑬			
⑭			
⑮			
⑯			
⑰			
⑱			
⑲			
⑳			
㉑			
㉒			
㉓			
㉔			
㉕			
㉖			
㉗			
㉘			
㉙			
㉚			
㉛			
㉜			
㉝			
㉞			
㉟			
㊱			
㊲			
㊳			
㊴			
㊵			
㊶			
㊷			
㊸			
㊹			
㊺			
㊻			
㊼			
㊽			
㊾			
㊿			
①	04-04-92	Any	
②			
③			
④			
⑤			
⑥			
⑦			
⑧			
⑨			
⑩			
⑪			
⑫			
⑬			
⑭			
⑮			
⑯			
⑰			
⑱			
⑲			
⑳			
㉑			
㉒			
㉓			
㉔			
㉕			
㉖			
㉗			
㉘			
㉙			
㉚			
㉛			
㉜			
㉝			
㉞			
㉟			
㊱			
㊲			
㊳			
㊴			
㊵			
㊶			
㊷			
㊸			
㊹			
㊺			
㊻			
㊼			
㊽			
㊾			
㊿			
①	04-04-92	Any	
②			
③			
④			
⑤			
⑥			
⑦			
⑧			
⑨			
⑩			
⑪			
⑫			
⑬			
⑭			
⑮			
⑯			
⑰			
⑱			
⑲			
⑳			
㉑			
㉒			
㉓			
㉔			
㉕			
㉖			
㉗			
㉘			
㉙			
㉚			
㉛			
㉜			
㉝			
㉞			
㉟			
㊱			
㊲			
㊳			
㊴			
㊵			
㊶			
㊷			
㊸			
㊹			
㊺			
㊻			
㊼			
㊽			
㊾			
㊿			
①	04-04-92	Any	
②			
③			
④			
⑤			
⑥			
⑦			
⑧			
⑨			
⑩			
⑪			
⑫			
⑬			
⑭			
⑮			
⑯			
⑰			
⑱			
⑲			
⑳			
㉑			
㉒			
㉓			
㉔			
㉕			
㉖			
㉗			
㉘			
㉙			
㉚			
㉛			
㉜			
㉝			
㉞			
㉟			
㊱			
㊲			
㊳			
㊴			
㊵			
㊶			
㊷			
㊸			
㊹			
㊺			
㊻			
㊼			
㊽			
㊾			
㊿			
①	04-04-92	Any	
②			
③			
④			
⑤			
⑥			
⑦			
⑧			
⑨			
⑩			
⑪			
⑫			
⑬			
⑭			
⑮			
⑯			
⑰			
⑱			
⑲			
⑳			
㉑			
㉒			
㉓			
㉔			
㉕			
㉖			
㉗			
㉘			
㉙			
㉚			
㉛			
㉜			
㉝			
㉞			
㉟			
㊱			
㊲			
㊳			
㊴			
㊵			
㊶			
㊷			
㊸			
㊹			
㊺			
㊻			
㊼			
㊽			
㊾			
㊿			
①	04-04-92	Any	
②			
③			
④			
⑤			
⑥			
⑦			
⑧			
⑨			
⑩			
⑪			
⑫			
⑬			
⑭			
⑮			
⑯			
⑰			
⑱			
⑲			
⑳			
㉑			
㉒			
㉓			
㉔			
㉕			
㉖			
㉗			
㉘			
㉙			
㉚			

Control Room Monitor Unit 1.912.420

IND	POS NO	PART NO	VALUE	SPECIFICATIONS/EQUIVALENT		MFR
	R146	57.11.4102	1 k			
	R147	57.11.4563	56 k			
	R148	57.11.4223	22k			
	R149	57.11.11102	1k			
	R150	57.11.4682	68k			
	R151	57.11.4102	1k			
	R152	57.11.4470	47			
	R153	57.11.4470	47			
	R154	57.99.0209	5,6	PTC		
	R155	57.99.0209	5,6	PTC	Philips	
	R156	57.99.0209	5,6	PTC	2322.662.31005	
	R157	57.99.0209	5,6	PTC		
	S1	55.15.0003	2u, Au			
	S2	55.15.0003	2u, Au			
	S3	55.15.0003	2u, Au			
	S4	55.15.0003	2u, Au			
	S5	55.15.0113	1u			
	S6	55.15.0113	1u			
	S7	55.15.0004	4u, Au			
	S8	55.15.0002	2u Ag			
	S9-S23	55.15.0008	15x2u, Au			
	T1,T2	1.022.352.00	17:1	Output Trafo		Studer
	VCM,2	1.010.110.50		Voltage Controlled Ampl.		Studer
	XB	55.15.0101	W2*4,6D	Lamp Holder		
	X1C	53.03.0166	DIP 8p	IC-Socket 8 pins		

IND	DATE	NAME
④		
③		
②		
①		
○	04-01-82	My

STUDER	C.R. MONITOR UNIT 2CH	PL	1.912.420	PAGE 3 OF 3
--------	-----------------------	----	-----------	-------------

Auxiliary Monitor Selector 1.912.460

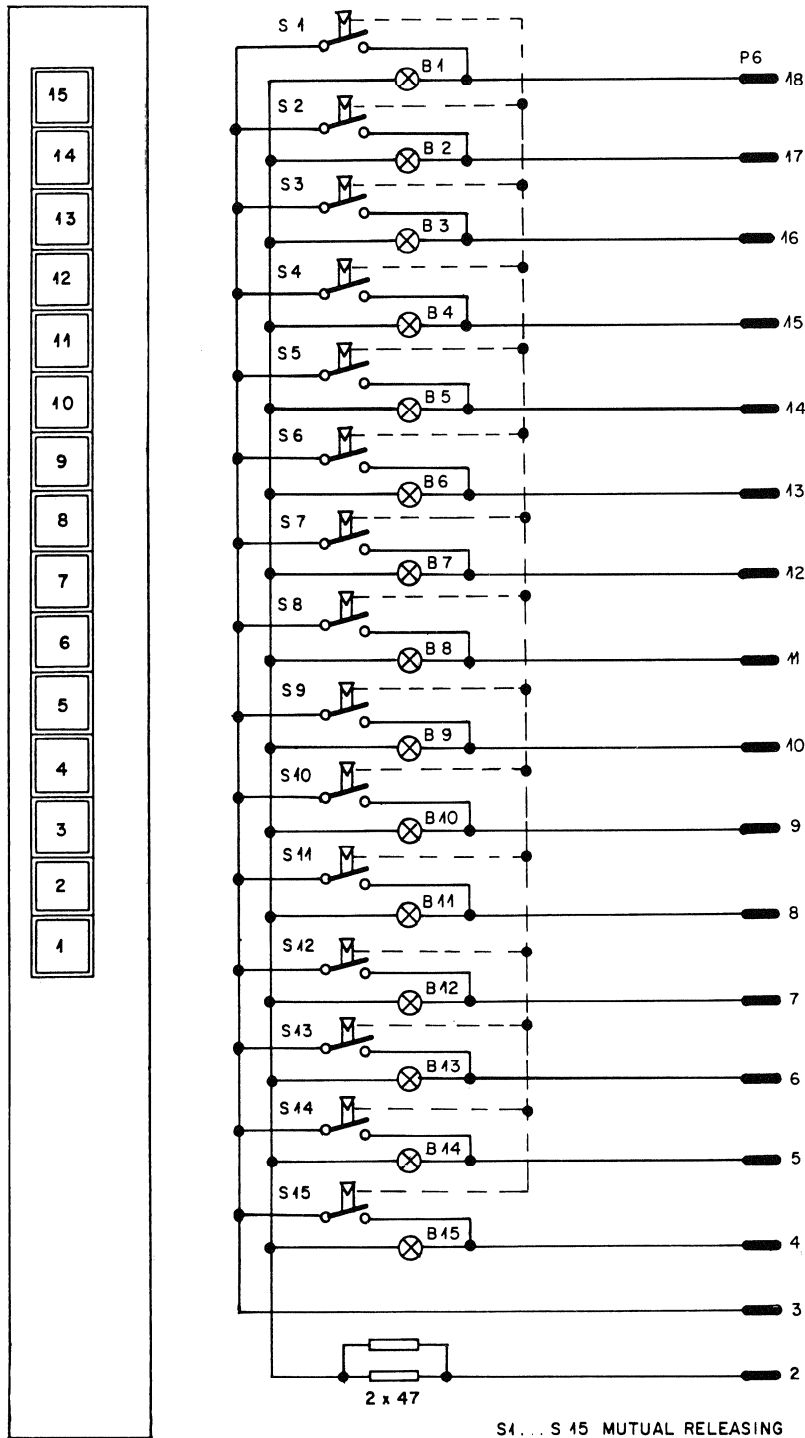

DATE:	31. 5. 83				
SIGN:	We				
STUDER REGENSDORF ZÜRICH	AUX MONITOR			SC 1.912.460	

Auxiliary Monitor Selector 1.912.460

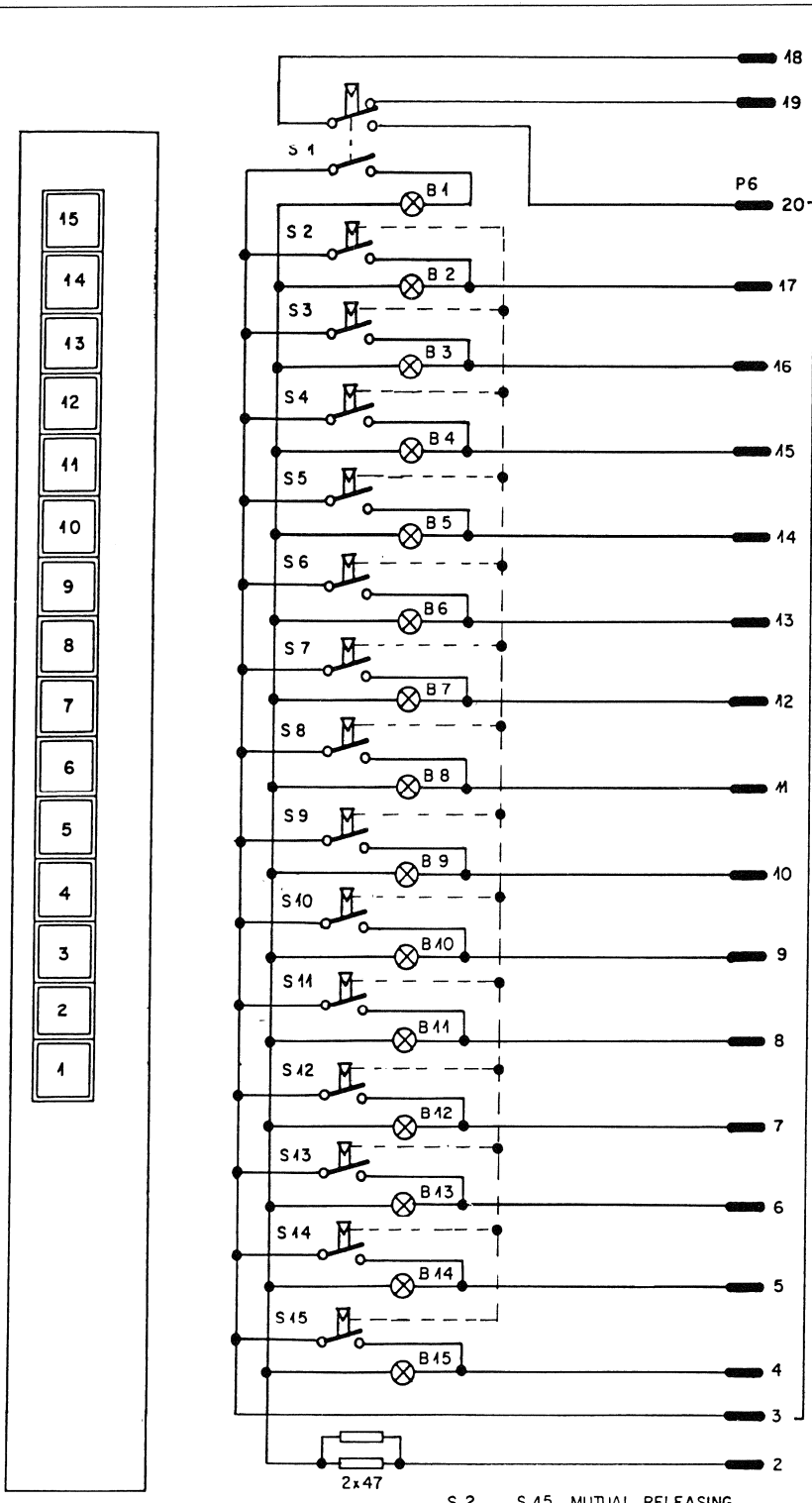

S 2 ... S 15 MUTUAL RELEASING

DATE:	11. 10. 83				
SIGN:	<i>Ge</i>				
STUDER REGENSDORF ZÜRICH	AUX MONITOR				SC 1.912.460.81

Summen-Ausgangswähler

Dieser Ausgangswähler kann ein Summensignal auf vier Sammelschienen verteilen und bietet zusätzlich die Möglichkeit, auf vier Hilfswege einzuspeisen. Die Einheit kann bei Summen oder Gruppen eingesetzt werden. Da kanalweise getrennt geschaltet wird, sind alle Möglichkeiten der Kanalvertauschung, der Monobildung und der Verteilung auf mehrere Ausgangskanäle gegeben.

Das Summen- bzw. Gruppensignal wird hinter dem Masterfader abgegriffen und dem Ausgangswähler zugeführt. Ein Abgriff vor dem Regler speist die Anwahl zu den Hilfssummen.

Ausgangswahl bei Summen

In dieser Konfiguration kann jeder Summenkanal auf jeden der vier Summenausgänge einspeisen. Dazu werden die Sammelschienen OUTPUT BUS eingesetzt. Die Leitungsverstärker der Summeneinheiten greifen jeweils die Sammelschiene OUTPUT BUS gleicher Nummer ab und führen das Signal dem zugehörigen Summenausgang MAIN OUTPUT zu.

Die Ausgangswahl zu den Summenausgängen muss in jedem Fall betätigt werden, ansonsten liegt kein Summensignal an.

Ausgangswahl bei Gruppen

Bei Gruppeneinheiten wird der Ausgangswähler als Summenanwahl eingesetzt. Die Gruppeneinheiten greifen jeweils einen GROUP BUS ab und speisen ihn auf den Gruppenausgang. Nach dem Gruppenregler wird nun das Signal abgezweigt und über den Ausgangswähler den Summensammelschienen zugeführt. Es stehen also sowohl die einzelnen Gruppenausgänge als auch vier beliebige, daraus gebildete Summen zur Verfügung.

Falls nur die Gruppensignale gebraucht werden, muss keine Ausgangswahl vorgenommen werden.

Hilfssummen AUX 1... 3

Die Modulation lässt sich über die mit dem Potentiometer gekoppelten Zug-/ Druckschalter vor (PF) oder nach (AF) dem Summenregler abgreifen. Aux 1... 3 sind Mono-Hilfswege.

AUX 4

Die Einspeisung auf den Stereo-Hilfsweg AUX 4 erfolgt über ein Panorama-Potentiometer.

Technische Daten

Frequenzgang	30Hz... 16kHz	±0,5dB
Klirrabstand		-70dB
Fremdspannungsabstand (B = 23kHz)		100dB
Übersprechen		90dB

Speisung

Speisespannung	±15V
Leerlaufstrom	50mA

Mechanische Daten

Abmessungen Frontplatte	520mm × 40mm
Tiefe	130mm
Gewicht	680g

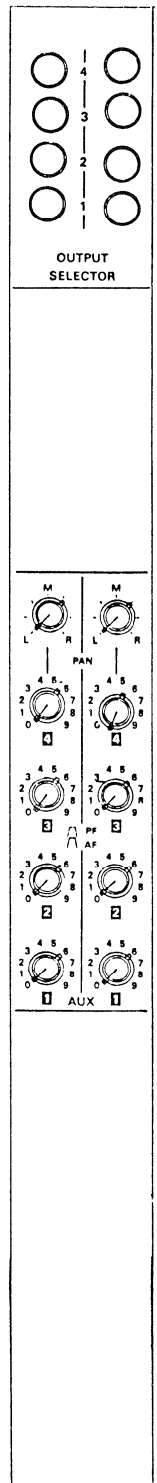

Summen-Ausgangswahl / Master Output Selection

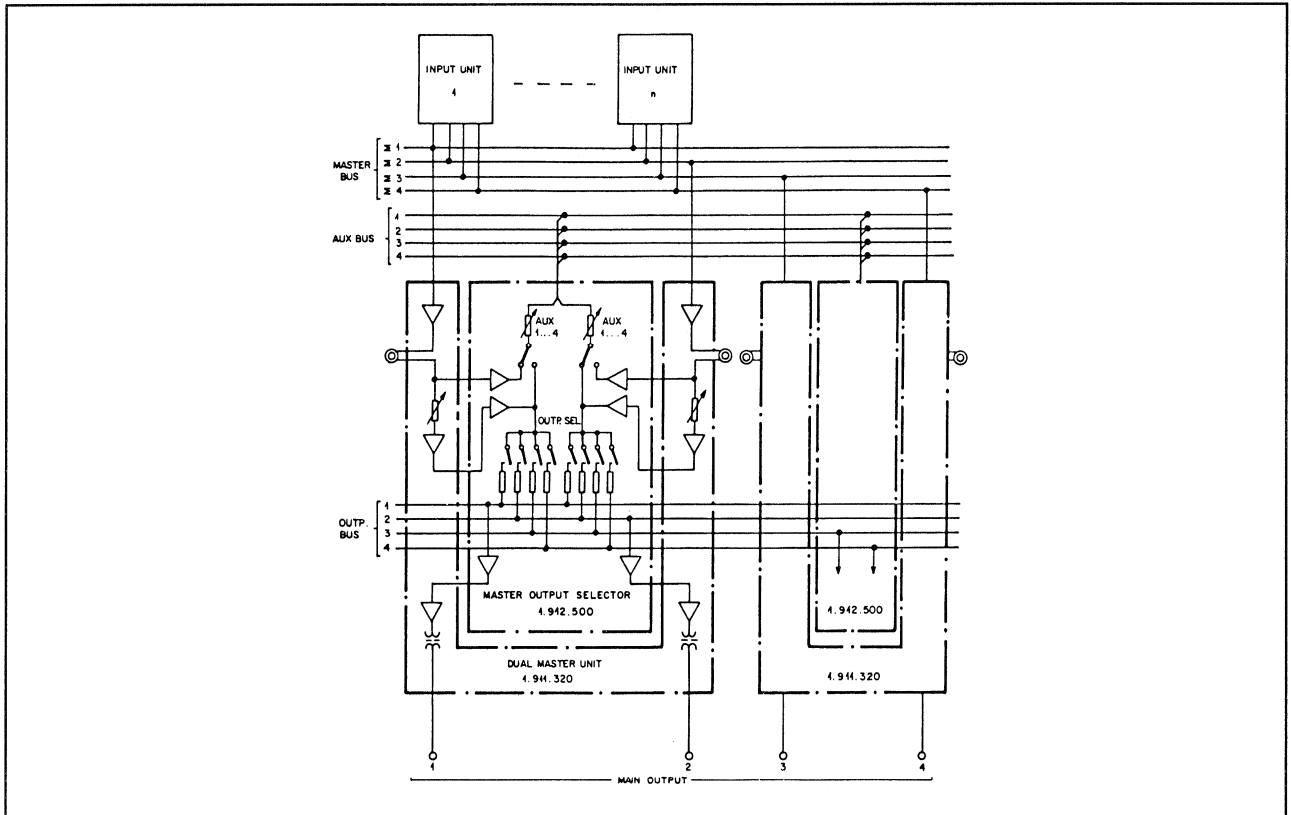

Gruppen-Ausgangswahl / Group Output Selection

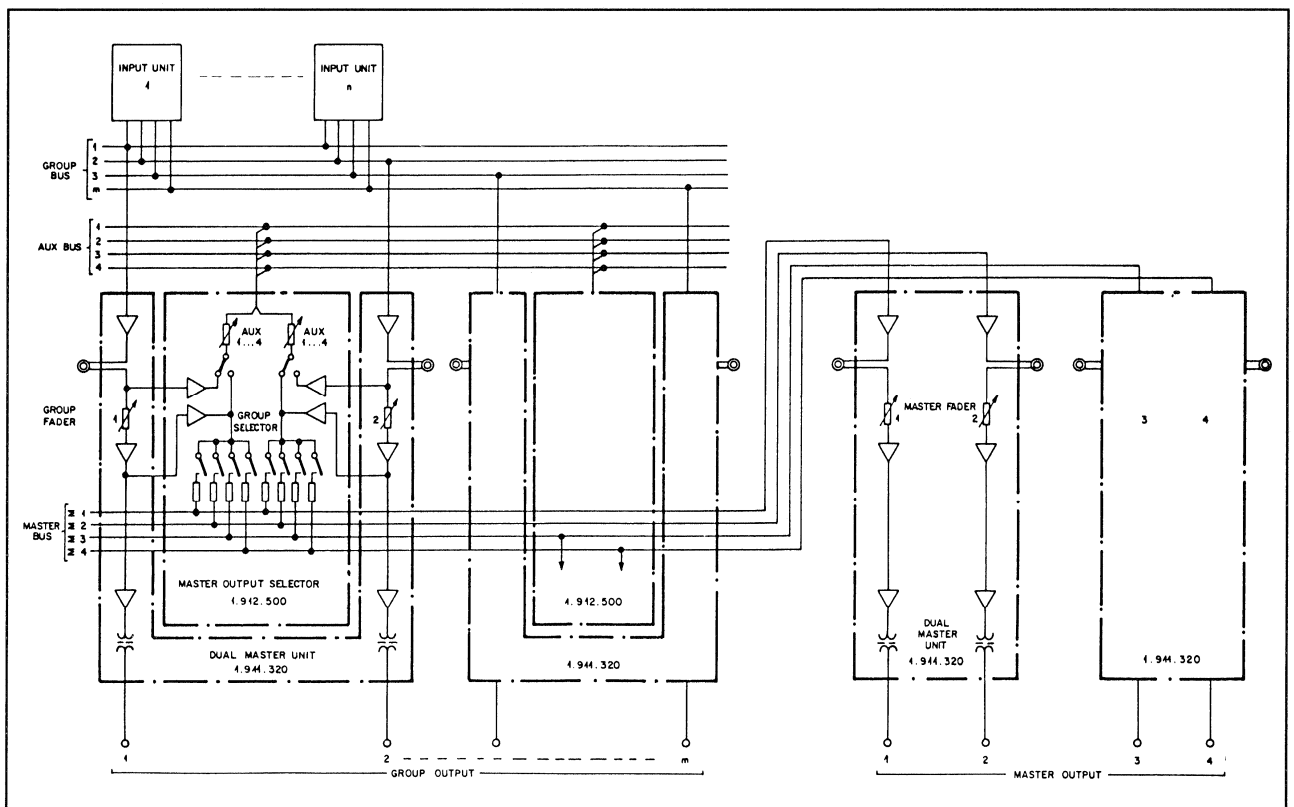

Master Output Selector 1.912.500

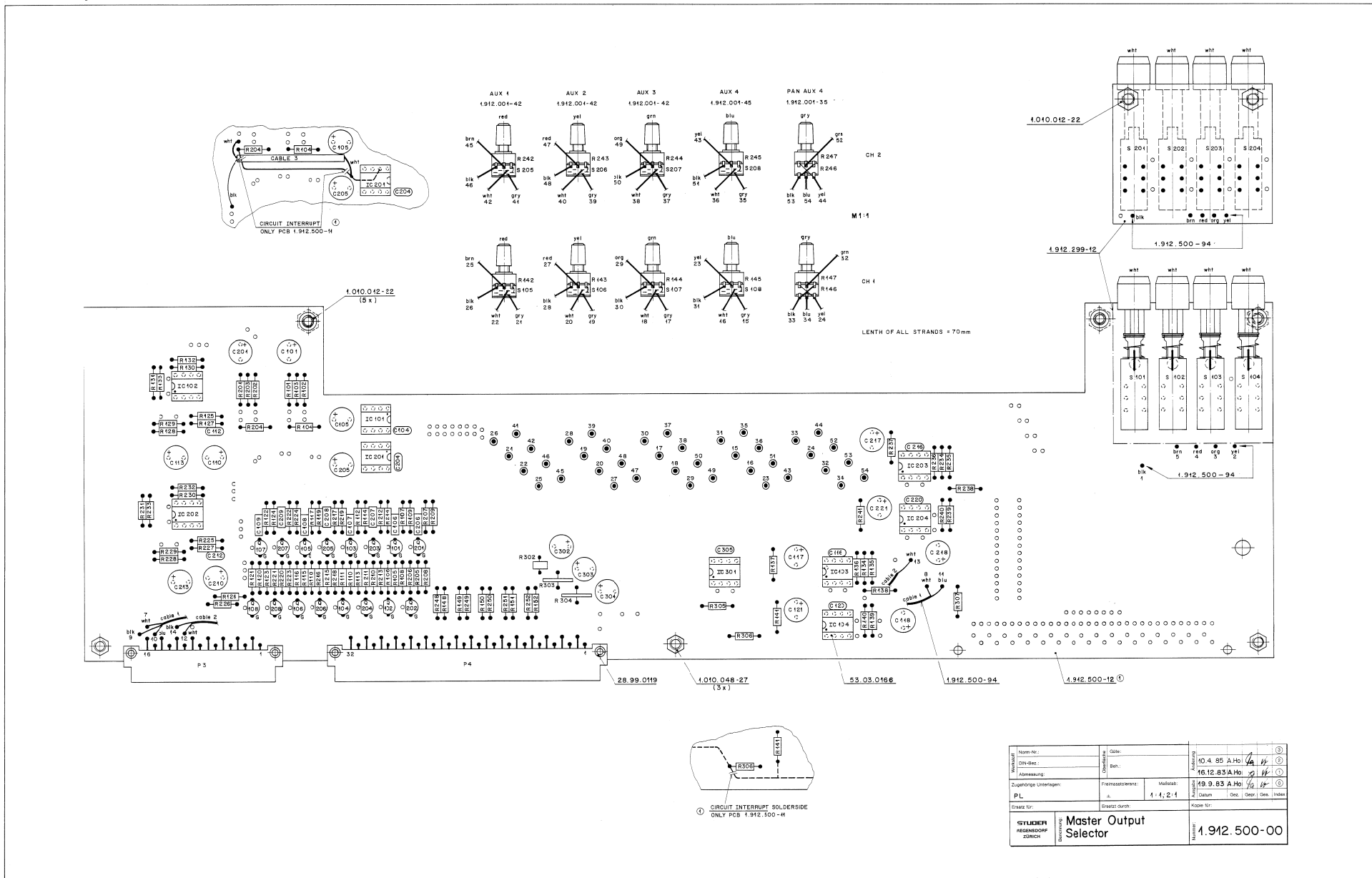

Norm-Nr.:	1.912.500	Größe:	10.4.85 A.Hd
Gr.-Bez.:	1.912.500	Beh.:	16.12.83 A.Hd
Abmessung:	19.9.83 A.Hd	Material:	1.4; 2.1
Zugfertige Unterlagen:	1.4; 2.1	Datum:	1.4; 2.1
PL:	1.4; 2.1	Gez.:	
Erstellt für:	Erstellt durch:	Kontrolliert:	
STUDER REGISSTRAPP ZÜRICH		Master Output Selector	
		Material-Nr.: 1.912.500-00	

Master Output Selector 1.912.500

IND POS NO	PART NO	VALUE	SPECIFICATIONS/EQUIVALENT	MFR
1./2.				
C. 57	59.22.5101	100 μ	46V EL	
.04	59.34.2220	22 p	CER	
.05	59.22.5101	100 μ	46V EL	
.06	59.06.0682	6.8 n	63V PE	
.07	59.06.0682	6.8 n	63V PE	
.08	59.06.0682	6.8 n	63V PE	
.09	59.06.0682	6.8 n	63V PE	
.10	59.22.2221	220 k	6V EL	
.12	59.34.5531	560 p	CER	
.13	59.22.5101	100 μ	46V EL	
.16	59.34.2220	22 p	CER	
.17	59.22.5101	100 μ	46V EL	
.18	59.22.5101	100 μ	46V EL	
.20	59.34.2220	22 p	CER	
.21	59.22.5101	100 μ	46V EL	
C. 304	59.22.5101	100 μ	25V EL	
353	59.22.5101	100 μ	46V EL	

IND	DATE	NAME	
①			CER: CERAMIC
②			EL: ELECTROLYTIC
③	10.4.85	fa	PE: POLYESTER
④	4.10.84	fa	
⑤	17.8.82	TAMAS fa	

MASTER OUTPUT SELECTOR PL 1.912.500.00 PAGE 1 of 5

IND POS NO	PART NO	VALUE	SPECIFICATIONS/EQUIVALENT	MFR
R. 07	50.03.0350	J 112		SX
.08	50.03.0350	J 112		*
1./2.				
2 R. 04	57.11.3562	5.6 k	1%	
.02	57.11.4474	470 n		
.03	57.11.4474	470 n		
.04	57.11.3562	5.6 k	1%	
.05	57.11.4333	33 k		
.06	57.11.4332	33 k		
.07	57.11.5106	10 M		
.08	57.11.5106	10 M		
.09	57.11.4104	100 k		
.10	57.11.4332	33 k		
.11	57.11.4332	33 k		
.12	57.11.5106	10 M		
.13	57.11.5106	10 M		
.14	57.11.4104	100 k		
.15	57.11.4333	33 k		
.16	57.11.4332	33 k		
.17	57.11.5106	10 M		
.18	57.11.5106	10 M		
.19	57.11.4104	100 k		
.20	57.11.4333	33 k		
.21	57.11.4332	33 k		
.22	57.11.5106	10 M		
.23	57.11.5106	10 M		
.24	57.11.4104	100 k		

IND	DATE	NAME	
①			ST: STUDER
②			
③	10.4.85	fa	
④	4.10.84	fa	
⑤	17.8.82	TAMAS fa	

MASTER OUTPUT SELECTOR PL 1.912.500.00 PAGE 3 of 5

IND POS NO	PART NO	VALUE	SPECIFICATIONS/EQUIVALENT	MFR
C. 304	59.22.5101	100 μ	46V EL	
1	305	59.34.4101	100 p	CER
1./2.				
1c. 01	50.05.0243	NE 5534	OP-AMP	SIG
.02	50.05.0105	NE 5532	DUAL OP-AMP	*
.03	50.05.0243	NE 5534	OP-AMP	*
.04	50.05.0243	NE 5534	OP-AMP	*
1c. 304	50.05.0243	NE 5534	OP-AMP	SIG
P. 3	54.11.2007	2 * 8	1/2 EURO B-TYPE	BU
4	54.01.0359	2 * 16	EURO B-TYPE	BU
1./2.				
R. 01	50.03.0350	J 112		SX
.02	50.03.0350	J 112		*
.03	50.03.0350	J 112		*
.04	50.03.0350	J 112		*
.05	50.03.0350	J 112		*
.06	50.03.0350	J 112		*

IND	DATE	NAME	
①			BU: BURNDY
②			SIG: SIGNETICK
③	10.4.85	fa	SX: SILICONX
④	4.10.84	fa	
⑤	17.8.82	TAMAS fa	

MASTER OUTPUT SELECTOR PL 1.912.500.00 PAGE 2 of 5

IND POS NO	PART NO	VALUE	SPECIFICATIONS/EQUIVALENT	MFR
2 R. 25	57.11.4333	33 k		
2 .26	57.11.4103	40 k		
2 .27	57.11.3362	3.6 k	1%	
2 .28	57.11.4333	33 k		
2 .29	57.11.4222	2.2 k		
2 .30	57.11.4222	2.2 k		
2 .31	57.11.4222	2.2 k		
2 .32	57.11.4222	2.2 k		
2 .33	57.11.4330	33		
2 .34	57.11.4222	2.2 k		
2 .35	57.11.4222	2.2 k		
2 .36	57.11.4222	2.2 k		
2 .37	57.11.4333	33 k		
2 .38	57.11.4222	2.2 k		
2 .39	57.11.4332	33 k		
2 .40	57.11.4332	33 k		
2 .41	57.11.4333	33 k		
.42	1.912.001.42	10 k	Pos. Loos. Pot	ST
.43	1.912.001.42	10 k	" " "	*
.44	1.912.001.42	10 k	" " "	*
.45	1.912.001.45	4.7 k	" " "	*
1464	1.912.001.35	10 k	Neo. Loos. Pot	ST
147		10 k	Pos. Loos. J	*
2464	1.912.001.35	10 k	Neo. Loos. Pot	ST
247		10 k	Pos. Loos. J	*
2 .48	57.11.4332	33 k		
2 .49	57.11.4332	33 k		
2 .50	57.11.4332	33 k		
2 .51	57.11.4332	33 k		
2 .52	57.11.4332	33 k		

IND	DATE	NAME	
①			ST: STUDER
②			
③	10.4.85	fa	
④	4.10.84	fa	
⑤	17.8.82	TAMAS fa	

MASTER OUTPUT SELECTOR PL 1.912.500.00 PAGE 4 of 5

IND POS NO	PART NO	VALUE	SPECIFICATIONS/EQUIVALENT	MFR
R. 02	57.99.0206	50 n	PTC	
300	57.99.0208	56 n	PTC	
304	57.99.0208	5.6 n	PTC	
305	54.11.4402	1 k		
306	54.11.4411	470 n		
307	54.11.4411	470 n		
1./2.				
S. 01	55.15.0002	2 p	PUSHBUTTON	
	55.03.0303		KNOB GREY/WITHE	
.02	55.15.0002	2 p	PUSHBUTTON	
	55.03.0303		KNOB GREY/WITHE	
.03	55.15.0002	2 p	PUSHBUTTON	
	55.03.0303		KNOB GREY/WITHE	
.04	55.15.0002	2 p	PUSHBUTTON	
	55.03.0303		KNOB GREY/WITHE	

IND	DATE	NAME	
①			
②			
③	10.4.85	fa	
④	4.10.84	fa	
⑤	17.8.82	TAMAS fa	

MASTER OUTPUT SELECTOR PL 1.912.500.00 PAGE 5 of 5

Monitor Mixer 1.912.510/511

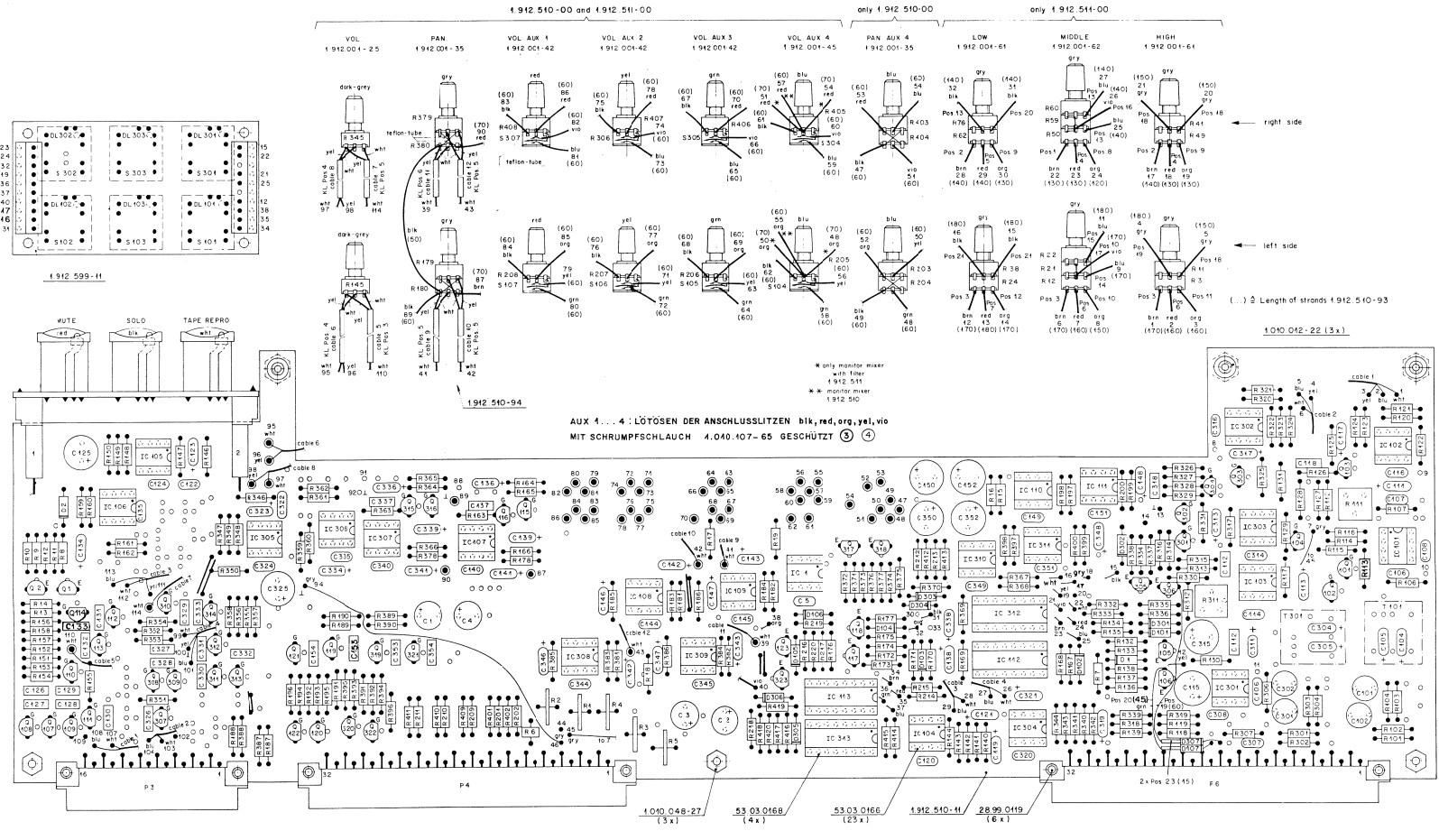

AUX 1...4: LÖTÖSEN DER ANSCHLUSSLITZEN blk, red, org, yel, vio
MIT SCHRUMPSCHLAUCH 4.040.407-65 GESCHÜTZT ③

VALID FOR	NR UNIT	PL	FILTER BOARD
MONITOR MIXER	1.912.510-00	1.912.510-00	—
MONITOR MIXER-FILTER	1.912.511-00	1.912.510-00	4.912.598-00

Name Nr 45.7.86 SI 4.7.84 SI 2.112.83 AHG 13.9.83 AHG	GdNr 1 2 3 4	17.2.88 SI 45.7.86 SI 4.7.84 SI 2.112.83 AHG 13.9.83 AHG	④ ③ ② ①
Zugabe/Entzug 1 2 3 4	Ersatz durch 1 2 3 4	1.912.510-00	④ ③ ② ①

STUDEM
RECHENBÜRO
ZÜRICH

Monitor Mixer

1.912.510-00

Monitor Mixer 1.912.510/511

Table with columns: IND/POS NO, PART NO, VALUE, SPECIFICATIONS/EQUIVALENT, MFR. Rows include components like resistors (C1, C2, C3, C4, C5), capacitors (C401, C402, C403, C404, C405, C406, C407, C408, C409, C410, C411, C412, C413, C414, C415, C416, C417, C418, C419, C420, C421, C422), and diodes (D1, D2, D401, D402, D403, D404, D405, D406, D407).

Table with columns: IND, DATE, NAME. Includes notes: 'option with input trifo', '* only trifo version', '† only normal version'. Includes a signature line for MONITOR MIXER, PL 1.912.510, PAGE 4 OF 10.

Table with columns: IND/POS NO, PART NO, VALUE, SPECIFICATIONS/EQUIVALENT, MFR. Rows include components like resistors (C453, C454, C301, C354, C404, C454), capacitors (D1, D2, D401, D402, D403, D404, D405, D406, D407), and diodes (DL101, DL102, DL103, DL301, DL302, DL303, DL401, DL402, DL403, DL301, DL302, DL303, DL401, DL402, DL403).

Table with columns: IND, DATE, NAME. Includes notes: 'option with input trifo', '* only trifo version', '† only normal version'. Includes a signature line for MONITOR MIXER, PL 1.912.510, PAGE 3 OF 10.

Table with columns: IND/POS NO, PART NO, VALUE, SPECIFICATIONS/EQUIVALENT, MFR. Rows include components like resistors (Q120, Q121, Q122, Q123), capacitors (R1, R2, R3, R4, R5, R6, R7, R8, R9, R10, R11, R12, R13, R14, R15, R16, R17, R18, R19), and diodes (R401, R402, R403).

Table with columns: IND, DATE, NAME. Includes notes: '* only trifo version', '† only normal version'. Includes a signature line for MONITOR MIXER, PL 1.912.510, PAGE 5 OF 10.

Table with columns: IND/POS NO, PART NO, VALUE, SPECIFICATIONS/EQUIVALENT, MFR. Rows include components like resistors (R134, R135, R136, R137, R138, R139, R140, R141, R142, R143, R144, R145, R146, R147, R148, R149, R150, R151, R152, R153, R154, R155, R156, R157, R158, R159, R160, R161, R162, R163).

Table with columns: IND, DATE, NAME. Includes notes: '* only trifo version', '† only normal version'. Includes a signature line for MONITOR MIXER, PL 1.912.510, PAGE 7 OF 10.

Table with columns: IND/POS NO, PART NO, VALUE, SPECIFICATIONS/EQUIVALENT, MFR. Rows include components like resistors (C423, C424, C425, C426, C427, C428, C429, C430, C431, C432, C433, C434, C435, C436, C437, C438, C439, C440, C441, C442, C443, C444, C445, C446, C447, C448, C449, C450, C451, C452), capacitors (C401, C402, C403, C404, C405, C406, C407, C408, C409, C410, C411, C412, C413, C414, C415, C416, C417, C418, C419, C420, C421, C422), and diodes (D1, D2, D401, D402, D403, D404, D405, D406, D407).

Table with columns: IND, DATE, NAME. Includes notes: 'option with input trifo', '* only trifo version', '† only normal version'. Includes a signature line for MONITOR MIXER, PL 1.912.510, PAGE 2 OF 10.

Table with columns: IND/POS NO, PART NO, VALUE, SPECIFICATIONS/EQUIVALENT, MFR. Rows include components like resistors (C401, C402, C403, C404, C405, C406, C407, C408, C409, C410, C411, C412, C413, C414, C415, C416, C417, C418, C419, C420, C421, C422), capacitors (C423, C424, C425, C426, C427, C428, C429, C430, C431, C432, C433, C434, C435, C436, C437, C438, C439, C440, C441, C442, C443, C444, C445, C446, C447, C448, C449, C450, C451, C452), and diodes (D1, D2, D401, D402, D403, D404, D405, D406, D407).

Table with columns: IND, DATE, NAME. Includes notes: 'option with input trifo', '* only trifo version', '† only normal version'. Includes a signature line for MONITOR MIXER, PL 1.912.510, PAGE 4 OF 10.

Table with columns: IND/POS NO, PART NO, VALUE, SPECIFICATIONS/EQUIVALENT, MFR. Rows include components like resistors (R401, R402, R403, R404, R405, R406, R407, R408, R409, R410, R411, R412, R413, R414, R415, R416, R417, R418, R419, R420, R421, R422, R423, R424, R425, R426, R427, R428, R429, R430, R431, R432, R433), capacitors (Q1, Q2, Q401, Q402, Q403, Q404, Q405), and diodes (Q401, Q402, Q403, Q404, Q405).

Table with columns: IND, DATE, NAME. Includes notes: '* only trifo version', '† only normal version'. Includes a signature line for MONITOR MIXER, PL 1.912.510, PAGE 6 OF 10.

Table with columns: IND/POS NO, PART NO, VALUE, SPECIFICATIONS/EQUIVALENT, MFR. Rows include components like resistors (R134, R135, R136, R137, R138, R139, R140, R141, R142, R143, R144, R145, R146, R147, R148, R149, R150, R151, R152, R153, R154, R155, R156, R157, R158, R159, R160, R161, R162, R163), capacitors (R401, R402, R403, R404, R405, R406, R407, R408, R409, R410, R411, R412, R413, R414, R415, R416, R417, R418, R419, R420, R421, R422, R423, R424, R425, R426, R427, R428, R429, R430, R431, R432, R433), and diodes (Q1, Q2, Q401, Q402, Q403, Q404, Q405).

Table with columns: IND, DATE, NAME. Includes notes: '* only trifo version', '† only normal version'. Includes a signature line for MONITOR MIXER, PL 1.912.510, PAGE 8 OF 10.

Monitor Mixer 1.912.510/511

IND	POS NO	PART NO	VALUE	SPECIFICATIONS/EQUIVALENT	MFR
	R194	57.11.4103	10k		
	R195	57.11.6106	10M		
	R196	57.11.6106	10M		
	R197	57.11.4332	3,3k		
	R198	57.11.4332	3,3k		
	R199	57.11.4332	3,3k		
	R200	57.11.4332	3,3k		
	R201	57.11.4332	3,3k	1.912.511: 4,7k 57.11.4472	
	R202	57.11.4332	3,3k	1.912.511: 4,7k 57.11.4472	
	R203	1.912.001.35	10k -log	only 1.912.510	
	R204		10k +log	only 1.912.510	
	R205	1.912.001.45	47k +log, S		
	R206	1.912.001.45	47k +log, S		
	R207	1.912.001.45	47k +log, S		
	R208	1.912.001.45	47k +log, S		
	R209	57.11.4332	3,3k		
	R210	57.11.4332	3,3k		
	R211	57.11.4332	3,3k		
	R212	57.11.4683	68k		
	R213	57.11.4683	68k		
	R214	57.11.4823	82k		
	R215	57.11.4823	82k		
	R216	57.11.4822	82k		
	R217	57.11.4333	33k		
	R218	57.11.4224	220k		
	R219	57.11.4391	390		
	R220	57.11.4154	150k		
	R301...R420	= R101...R220			

IND	DATE	NAME
④		
③		
②	4-10-84	fg
①	21-12-83	my
○	18-1-83	my

STUDER MONITOR MIXER PL 1.912.510 PAGE 9 OF 10

IND	POS NO	PART NO	VALUE	SPECIFICATIONS/EQUIVALENT	MFR
	S101	55.15.0113		double latching	
	S102	55.15.0112		latching - non latching	
	S103	55.15.0112		latching - non latching	
	S104			→ R205 (double latching)	
	S105			→ R206 . .	
	S106			→ R207 . .	
	S107			→ R208 . .	
	S301...S307	= S101...S107			
	T101	T301 *			
		1.022.419		only trofo version	
	X1C	53.03.0166		IC-socket DIL 8 pins	
	X1C	53.03.0168		IC-socket DIL 16 pins	
	A2	1.912.598.00		filter board for 1.912.511	

IND	DATE	NAME
④		
③		
②	4-10-84	fg
①	21-12-83	my
○	18-1-83	my

STUDER MONITOR MIXER PL 1.912.510 PAGE 10 OF 10

Monitor Mixer Filter Board 1.912.598.00

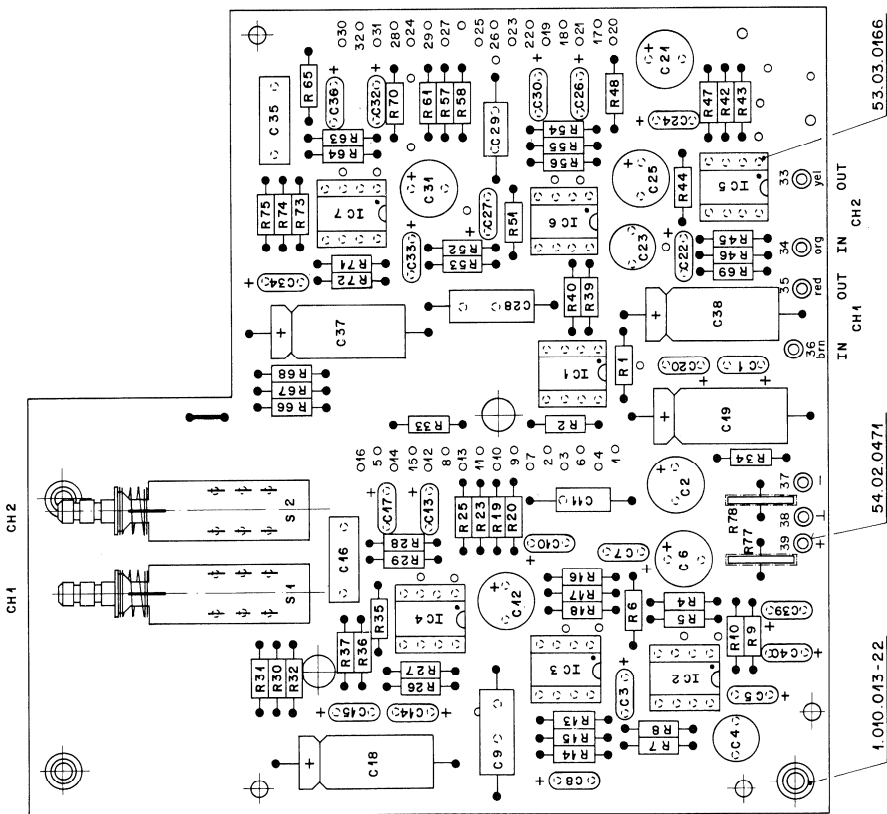
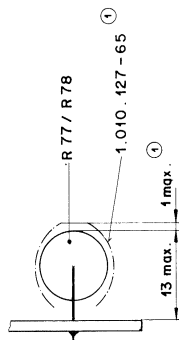
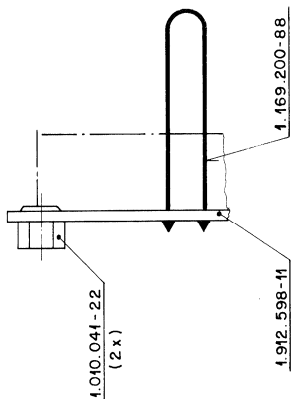

Norm-Nr.:	Güte:	④
DIN-Bez.:	Beh.:	②
Abmessung:	Oberfläche:	①
Zugehörige Unterlagen:	Freiwillige Unterl.:	①
PL	±	①
Ersatz für:	Ersetzt durch:	
STUDER REGENSDORF ZÜRICH	Filter Board Monitor Mixer	
	Nr.:	1.912.598-00

16.12.86	14	14	14
25.8.83	A.Hy	A.Hy	A.Hy
Datum	Gez.	Gepr.	Gez.
Kopie für:			
Index			

Monitor Mixer Filter Board 1.912.598.00

IND\POS NO	PART NO	VALUE	SPECIFICATIONS/EQUIVALENT	MFR
C1	59.26.0680	68μ	6V SAL	
C2	59.22.2221	220μ	6V EL radial	
C3	59.26.0680	68μ	6V SAL	
C4	59.05.1103	10n	1% PP	
C5	59.26.0680	68μ	6V SAL	
C6	59.22.2221	220μ	6V EL radial	
C7	59.26.0680	68μ	6V SAL	
C8	59.26.0680	68μ	6V SAL	
C9	59.12.7123	12n	1% PS	
C10	59.26.0680	68μ	6V SAL	
C11	59.12.7182	18n	1% PS	
C12	59.22.2221	220μ	6V EL radial	
C13	59.26.0680	68μ	6V SAL	
C14	59.26.0680	68μ	6V SAL	
C15	59.26.0680	68μ	6V SAL	
C16	59.11.3153	15n	5% PC 59.02.5153	
C17	59.26.0680	68μ	6V SAL	
C18	59.25.1471	470μ	6V EL axial	
C19	59.25.1471	470μ	6V EL axial	
C20	59.26.0680	68μ	6V SAL	
C21	59.22.2221	220μ	6V EL radial	
C22	59.26.0680	68μ	6V SAL	
C23	59.05.1103	10n	1% PP	
C24	59.26.0680	68μ	6V SAL	
C25	59.22.2221	220μ	6V EL radial	
C26	59.26.0680	68μ	6V SAL	
C27	59.26.0680	68μ	6V SAL	
C28	59.12.7123	12n	1% PS	
C29	59.12.7182	18n	1% PS	
C30	59.26.0680	68μ	6V SAL	
C31	59.22.2221	220μ	6V EL radial	
C32	59.26.0680	68μ	6V SAL	
C33	59.26.0680	68μ	6V SAL	
C34	59.26.0680	68μ	6V SAL	
C35	59.02.5153	15n	5% PC 59.11.3153	
C36	59.26.0680	68μ	6V SAL	
C37	59.25.1471	470μ	6V EL axial	
C38	59.25.1471	470μ	6V EL axial	
C39	59.26.2100	10μ	16V SAL	
C40	59.26.2100	10μ	16V SAL	
K1-7	50.09.0105	NE5532	dual op.amp	
X1C	53.03.0166		IC-socket 8pins	
R1	57.11.4472	47k		
R2	57.11.4472	47k		
R3	1.912.001.61	47k lin	potm. 1	
R4	57.11.4472	47k		
R5	57.11.4472	47k		
R6	57.11.4682	68k		
R7	57.11.4682	68k		
R8	57.11.4183	18k		
R9	57.11.4474	470k		
R10	57.11.4392	3,9k		
R11	1.912.001.61	100k neg.log	potm. 1	
R12	1.912.001.62	47k lin	potm. 2	
R13	57.11.4222	2,2k		
R14	57.11.4183	18k		
R15	57.11.4274	270k		
R16	57.11.4684	680k		
R17	57.11.4472	47k		
R18	57.11.4472	47k		
R19	57.11.4684	680k		
R20	57.11.4472	47k		
R21	1.912.001.62	100k neg.log	potm. 2	
R22		100k neg.log		
R23	57.11.4472	47k		
R24	1.912.001.61	47k lin	potm. 3	
R25	57.11.4682	68k		
R26	57.11.4682	68k		
R27	57.11.4183	18k		
R28	57.11.4472	47k		
R29	57.11.4472	47k		
R30	57.11.4683	68k		
R31	57.11.4472	47k		
R32	57.11.4683	68k		
R33	57.11.4220	2,2		
R34	57.11.4683	68k		

IND\POS NO	PART NO	VALUE	SPECIFICATIONS/EQUIVALENT	MFR
R35	57.11.4684	680k		
R36	57.11.4683	68k		
R37	57.11.4472	47k		
R38	1.912.001.61	100k neg.log	potm. 3	
R39	57.11.4472	47k		
R40	57.11.4472	47k		
R41	1.912.001.61	47k lin	potm. 4	
R42	57.11.4472	47k		
R43	57.11.4472	47k		
R44	57.11.4682	68k		
R45	57.11.4682	68k		
R46	57.11.4183	18k		
R47	57.11.4474	470k		
R48	57.11.4392	3,9k		
R49	1.912.001.61	100k neg.log	potm. 4	
R50	1.912.001.62	47k lin	potm. 5	
R51	57.11.4222	2,2k		
R52	57.11.4183	18k		
R53	57.11.4274	270k		
R54	57.11.4472	47k		
R55	57.11.4472	47k		
R56	57.11.4684	680k		
R57	57.11.4684	680k		
R58	57.11.4472	47k		
R59	1.912.001.62	100k neg.log	potm. 5	
R60		100k neg.log		
R61	57.11.4472	47k		
R62	1.912.001.61	47k lin	potm. 6	
R63	57.11.4472	47k		
R64	57.11.4472	47k		
R65	57.11.4683	68k		
R66	57.11.4472	47k		
R67	57.11.4683	68k		
R68	57.11.4220	2,2		
R69	57.11.4683	68k		
R70	57.11.4682	68k		
R71	57.11.4682	68k		
R72	57.11.4183	18k		
R73	57.11.4684	680k		
R74	57.11.4683	68k		
R75	57.11.4472	47k		
R76	1.912.001.61	100k neg.log	potm. 6	
R77	57.99.0209	5,6	PTC Philips	
R78	57.99.0209	5,6	PTC 2322.642.91005	
SA,2	55.15.0003		shadow ITT	

INDI	DATE	NAME	STUDER	FILTER BOARD	Mon.Mix.	PL	1.912.598
④							
③							
②							
①							
○	18-01-83	My					

Compact (Hex) Density Mixer 1.912.514

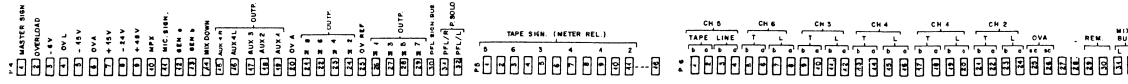
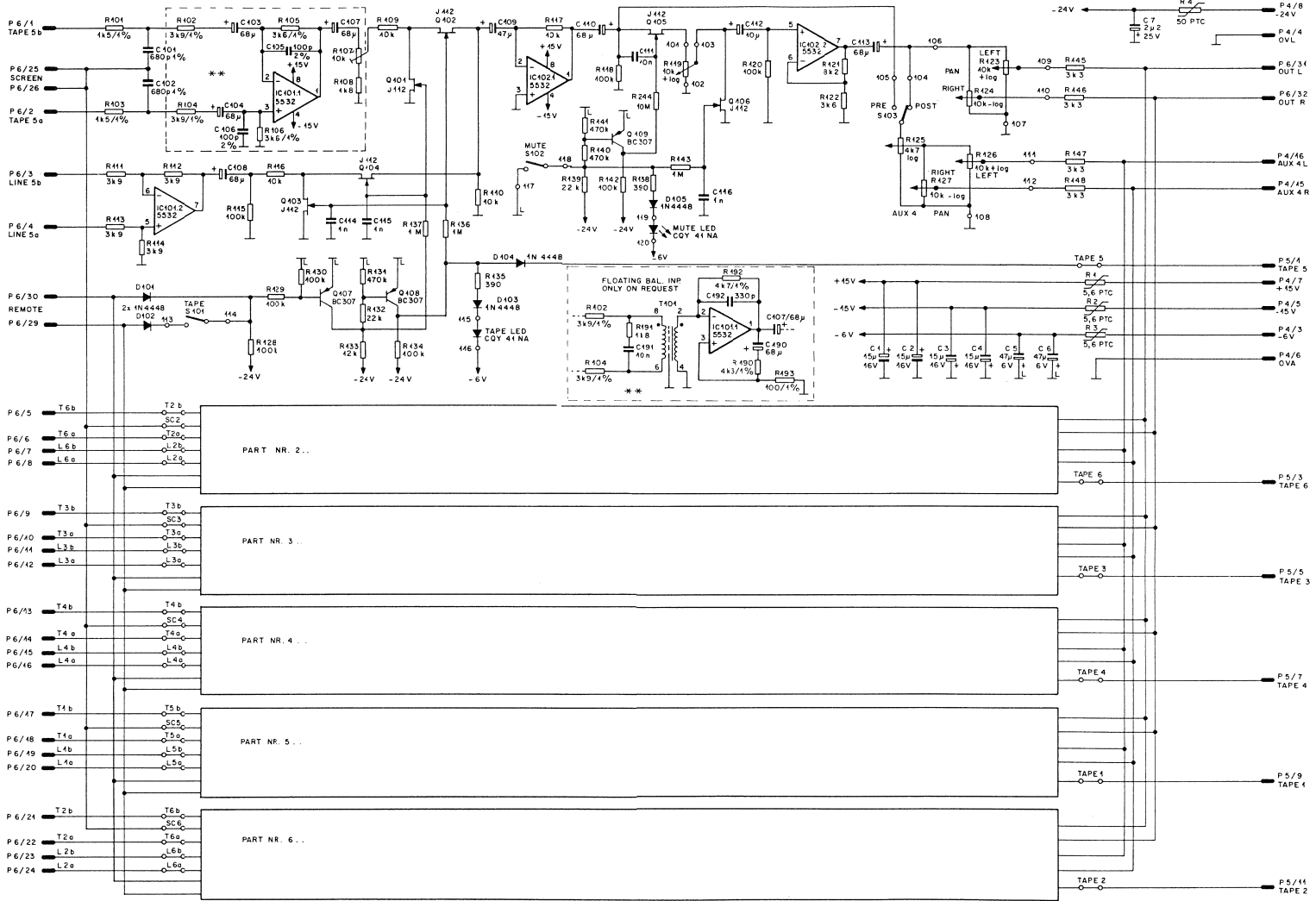

5.4.84	16.8.85		
MIXING CONSOLE 900		SC 1.912.514.00	
REGENDORF ZÜRICH			

Compact (Hex) Density Mixer 1.912.514

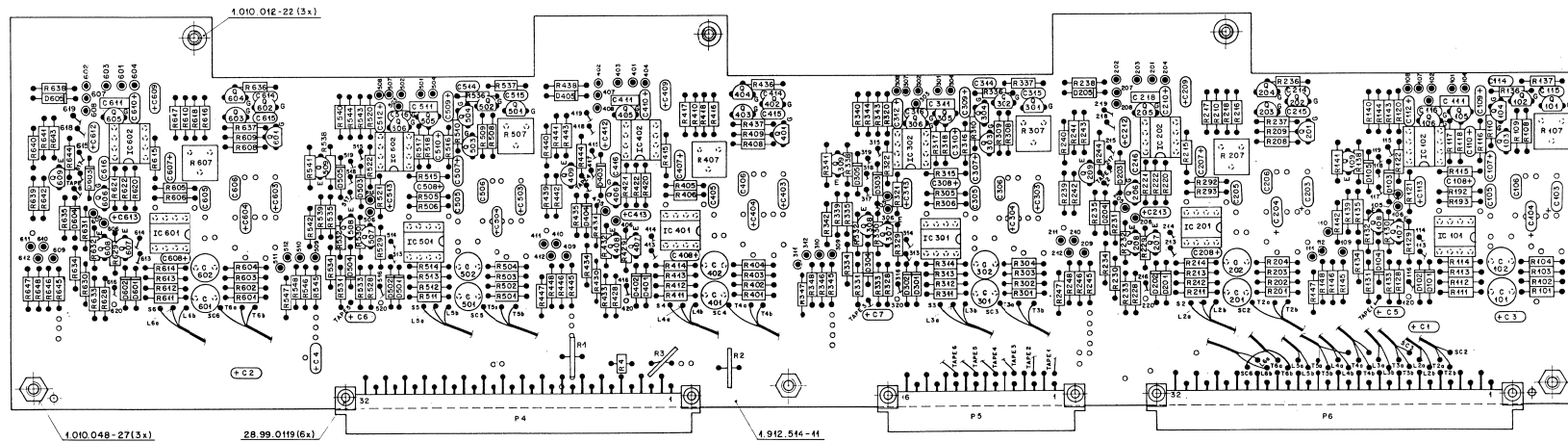
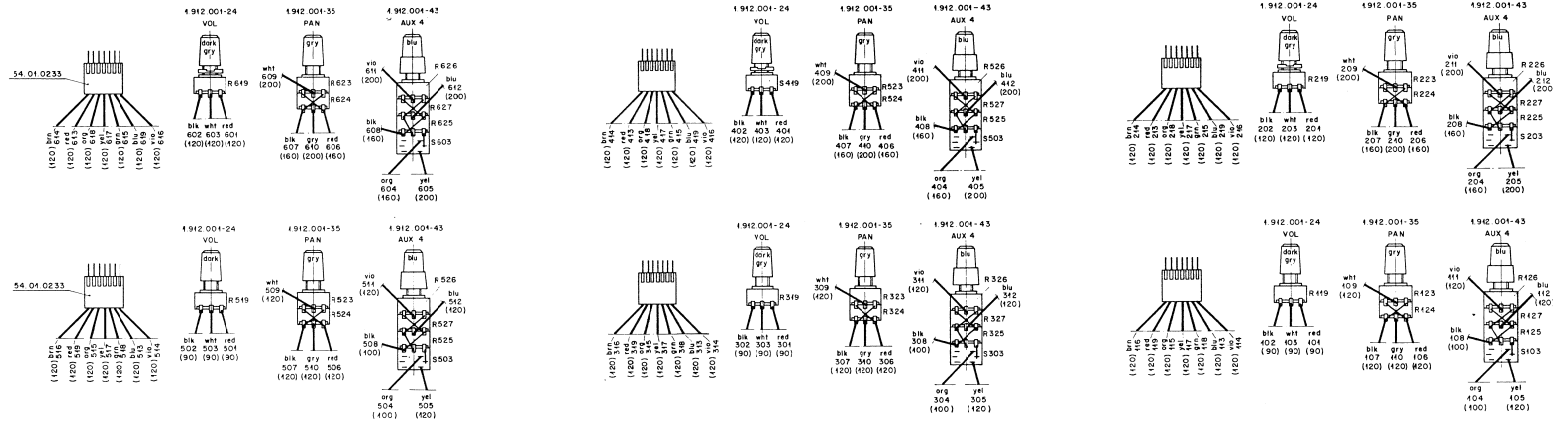

Norm Nr	Umriss	Umriss	Umriss	Umriss
DN Bez	Umriss	Umriss	Umriss	Umriss
Adressierung				
Zustimmung Unterlagen	Fremmsprachen	Material	6. H. 84 A. Ho	1
PL		2	1	1
Erstellt von	Erstellt durch	Weges Nr		
STYLINDER HOERHORNWERK ZÜRICH		COMPACT (HEX) DENSITY MONITOR		1. 912. 514- 00

Compact (Hex) Density Mixer 1.912.514

Table with columns: Ad, POS., REF. No., DESCRIPTION, MANUFACTURER. Contains component list for the mixer, including resistors, capacitors, and diodes.

Table with columns: Ad, POS., REF. No., DESCRIPTION, MANUFACTURER. Continuation of component list for the mixer.

Table with columns: Ad, POS., REF. No., DESCRIPTION, MANUFACTURER. Continuation of component list for the mixer.

Table with columns: Ad, POS., REF. No., DESCRIPTION, MANUFACTURER. Continuation of component list for the mixer.

Compact (Hex) Density Mixer 1.912.514

Ad	..POS.	..REF.No.	DESCRIPTION	MANUFACTURER	Ad	..POS.	..REF.No.	DESCRIPTION	MANUFACTURER
R...	393	.	100 Ohm	1% 0.25W MF (only for trafo input)	R...	591	.	1.8 kOhm	2% 0.25W MF (only for trafo input)
R...	401	57.11.3152	1.5 kOhm	1% 0.25W MF	R...	592	.	4.7 kOhm	1% 0.25W MF (only for trafo input)
R...	402	57.11.3392	3.9 kOhm	1% 0.25W MF	R...	593	.	100 Ohm	1% 0.25W MF (only for trafo input)
R...	403	57.11.3152	1.5 kOhm	1% 0.25W MF	R...	601	57.11.3152	1.5 kOhm	1% 0.25W MF
R...	404	57.11.3392	3.9 kOhm	1% 0.25W MF	R...	602	57.11.3392	3.9 kOhm	1% 0.25W MF
R...	405	57.11.3362	3.6 kOhm	1% 0.25W MF (for trafoless input)	R...	603	57.11.3152	1.5 kOhm	1% 0.25W MF
R...	406	57.11.3362	3.6 kOhm	1% 0.25W MF (for trafoless input)	R...	604	57.11.3392	3.9 kOhm	1% 0.25W MF
R...	407	58.01.8103	10 kOhm	10% 0.50W PMG trimming resistor	R...	605	57.11.3362	3.6 kOhm	1% 0.25W MF (for trafoless input)
R...	408	57.11.4182	1.8 kOhm	5% 0.25W MF	R...	606	57.11.3362	3.6 kOhm	1% 0.25W MF (for trafoless input)
R...	409	57.11.4103	10 kOhm	2% 0.25W MF	R...	607	58.01.8103	10 kOhm	10% 0.50W PMG trimming resistor
R...	410	57.11.4103	10 kOhm	5% 0.25W MF	R...	608	57.11.4182	1.8 kOhm	5% 0.25W MF
R...	411	57.11.3392	3.9 kOhm	1% 0.25W MF	R...	609	57.11.4103	10 kOhm	2% 0.25W MF
R...	412	57.11.3392	3.9 kOhm	1% 0.25W MF	R...	610	57.11.4103	10 kOhm	5% 0.25W MF
R...	413	57.11.3392	3.9 kOhm	1% 0.25W MF	R...	611	57.11.3392	3.9 kOhm	1% 0.25W MF
R...	414	57.11.3392	3.9 kOhm	1% 0.25W MF	R...	612	57.11.3392	3.9 kOhm	1% 0.25W MF
R...	415	57.11.4104	100 kOhm	5% 0.25W MF	R...	613	57.11.3392	3.9 kOhm	1% 0.25W MF
R...	416	57.11.4103	10 kOhm	2% 0.25W MF	R...	614	57.11.3392	3.9 kOhm	1% 0.25W MF
R...	417	57.11.4103	10 kOhm	2% 0.25W MF	R...	615	57.11.4104	100 kOhm	5% 0.25W MF
R...	418	57.11.4104	100 kOhm	5% 0.25W MF	R...	616	57.11.4103	10 kOhm	2% 0.25W MF
R...	419	1.912.001.24	10 kOhm	10% pos.log.variable resistor	R...	617	57.11.4103	10 kOhm	2% 0.25W MF
R...	420	57.11.4104	100 kOhm	5% 0.25W MF	R...	618	57.11.4104	100 kOhm	5% 0.25W MF
R...	421	57.11.4822	8.2 kOhm	2% 0.25W MF	R...	619	1.912.001.24	10 kOhm	10% pos.log.variable resistor
R...	422	57.11.3362	3.6 kOhm	1% 0.25W MF	R...	620	57.11.4104	100 kOhm	5% 0.25W MF
R...	423	1.912.001.35	10 kOhm	10% pos.log.variable resistor	R...	621	57.11.4822	8.2 kOhm	2% 0.25W MF
R...	424	.	10 kOhm	10% neg.log.variable resistor, see R423 St	R...	622	57.11.3362	3.6 kOhm	1% 0.25W MF
R...	425	1.912.001.43	4.7 kOhm	10% pos.log.variable resistor	R...	623	1.912.001.35	10 kOhm	10% pos.log.variable resistor
R...	426	.	10 kOhm	10% pos.log.variable resistor, see R425 St	R...	624	.	10 kOhm	10% neg.log.variable resistor, see R623 St
R...	427	.	10 kOhm	10% neg.log.variable resistor, see R425 St	R...	625	1.912.001.43	4.7 kOhm	10% pos.log.variable resistor
R...	428	57.11.4104	100 kOhm	5% 0.25W MF	R...	626	.	10 kOhm	10% pos.log.variable resistor, see R625 St
R...	429	57.11.4104	100 kOhm	5% 0.25W MF	R...	627	.	10 kOhm	10% neg.log.variable resistor, see R625 St
R...	430	57.11.4104	100 kOhm	5% 0.25W MF	R...	628	57.11.4104	100 kOhm	5% 0.25W MF
R...	431	57.11.4474	470 kOhm	5% 0.25W MF	R...	629	57.11.4104	100 kOhm	5% 0.25W MF
R...	432	57.11.4223	22 kOhm	5% 0.25W MF	R...	630	57.11.4104	100 kOhm	5% 0.25W MF
R...	433	57.11.4123	12 kOhm	5% 0.25W MF	R...	631	57.11.4474	470 kOhm	5% 0.25W MF
R...	434	57.11.4104	100 kOhm	5% 0.25W MF	R...	632	57.11.4223	22 kOhm	5% 0.25W MF
R...	435	57.11.4391	390 Ohm	5% 0.25W MF	R...	633	57.11.4123	12 kOhm	5% 0.25W MF
R...	436	57.11.4105	1 MOhm	5% 0.25W MF	R...	634	57.11.4104	100 kOhm	5% 0.25W MF
R...	437	57.11.4105	1 MOhm	5% 0.25W MF	R...	635	57.11.4391	390 Ohm	5% 0.25W MF
R...	438	57.11.4391	390 Ohm	5% 0.25W MF	R...	636	57.11.4105	1 MOhm	5% 0.25W MF
R...	439	57.11.4223	22 kOhm	5% 0.25W MF	R...	637	57.11.4105	1 MOhm	5% 0.25W MF
R...	440	57.11.4474	470 kOhm	5% 0.25W MF	R...	638	57.11.4391	390 Ohm	5% 0.25W MF
R...	441	57.11.4474	470 kOhm	5% 0.25W MF	R...	639	57.11.4223	22 kOhm	5% 0.25W MF
R...	442	57.11.4104	100 kOhm	5% 0.25W MF	R...	640	57.11.4474	470 kOhm	5% 0.25W MF
R...	443	57.11.4105	1 MOhm	5% 0.25W MF	R...	641	57.11.4474	470 kOhm	5% 0.25W MF
R...	444	57.11.6106	10 MOhm	10% 0.25W MF	R...	642	57.11.4104	100 kOhm	5% 0.25W MF
R...	445	57.11.4332	3.3 kOhm	2% 0.25W MF	R...	643	57.11.4105	1 MOhm	5% 0.25W MF
R...	446	57.11.4332	3.3 kOhm	2% 0.25W MF	R...	644	57.11.6106	10 MOhm	10% 0.25W MF
R...	447	57.11.4332	3.3 kOhm	2% 0.25W MF	R...	645	57.11.4332	3.3 kOhm	2% 0.25W MF
R...	448	57.11.4332	3.3 kOhm	2% 0.25W MF	R...	646	57.11.4332	3.3 kOhm	2% 0.25W MF
R...	490	.	4.3 kOhm	1% 0.25W MF (only for trafo input)	R...	647	57.11.4332	3.3 kOhm	2% 0.25W MF
R...	491	.	1.8 kOhm	2% 0.25W MF (only for trafo input)	R...	648	57.11.4332	3.3 kOhm	2% 0.25W MF
R...	492	.	4.7 kOhm	1% 0.25W MF (only for trafo input)	R...	690	.	4.3 kOhm	1% 0.25W MF (only for trafo input)
R...	493	.	100 Ohm	1% 0.25W MF (only for trafo input)	R...	691	.	1.8 kOhm	2% 0.25W MF (only for trafo input)
R...	501	57.11.3152	1.5 kOhm	1% 0.25W MF	R...	692	.	4.7 kOhm	1% 0.25W MF (only for trafo input)
R...	502	57.11.3392	3.9 kOhm	1% 0.25W MF	R...	693	.	100 Ohm	1% 0.25W MF (only for trafo input)
R...	503	57.11.3152	1.5 kOhm	1% 0.25W MF	S...	101	.	1*U	see 1.912.597.00
R...	504	57.11.3392	3.9 kOhm	1% 0.25W MF	S...	102	.	1*U	see 1.912.597.00
R...	505	57.11.3362	3.6 kOhm	1% 0.25W MF (for trafoless input)	S...	103	.	2*U	combined with variable resistor R 125 St
R...	506	57.11.3362	3.6 kOhm	1% 0.25W MF (for trafoless input)	S...	201	.	1*U	see 1.912.597.00
R...	507	58.01.8103	10 kOhm	10% 0.50W PMG trimming resistor	S...	202	.	1*U	see 1.912.597.00
R...	508	57.11.4182	1.8 kOhm	5% 0.25W MF	S...	203	.	2*U	combined with variable resistor R 225 St
R...	509	57.11.4103	10 kOhm	2% 0.25W MF	S...	301	.	1*U	see 1.912.597.00
R...	510	57.11.4103	10 kOhm	5% 0.25W MF	S...	302	.	1*U	see 1.912.597.00
R...	511	57.11.3392	3.9 kOhm	1% 0.25W MF	S...	303	.	2*U	combined with variable resistor R 325 St
R...	512	57.11.3392	3.9 kOhm	1% 0.25W MF	S...	401	.	1*U	see 1.912.597.00
R...	513	57.11.3392	3.9 kOhm	1% 0.25W MF	S...	402	.	1*U	see 1.912.597.00
R...	514	57.11.3392	3.9 kOhm	1% 0.25W MF	S...	403	.	2*U	combined with variable resistor R 425 St
R...	515	57.11.4104	100 kOhm	5% 0.25W MF	S...	501	.	1*U	see 1.912.597.00
R...	516	57.11.4103	10 kOhm	2% 0.25W MF	S...	502	.	1*U	see 1.912.597.00
R...	517	57.11.4103	10 kOhm	2% 0.25W MF	S...	503	.	2*U	combined with variable resistor R 525 St
R...	518	57.11.4104	100 kOhm	5% 0.25W MF	S...	601	.	1*U	see 1.912.597.00
R...	519	1.912.001.24	10 kOhm	10% pos.log.variable resistor	S...	602	.	1*U	see 1.912.597.00
R...	520	57.11.4104	100 kOhm	5% 0.25W MF	S...	603	.	2*U	combined with variable resistor R 625 St
R...	521	57.11.4822	8.2 kOhm	2% 0.25W MF	T...	601	.	.	input trafo 1:0.62 (only trafo input) St
R...	522	57.11.3362	3.6 kOhm	1% 0.25W MF	XIC...	1	53.03.0166	IC-socket D1L 8 pin	
R...	523	1.912.001.35	10 kOhm	10% pos.log.variable resistor	XIC...	2	53.03.0166	IC-socket D1L 8 pin	
R...	524	.	10 kOhm	10% neg.log.variable resistor, see R523 St	XIC...	3	53.03.0166	IC-socket D1L 8 pin	
R...	525	1.912.001.43	4.7 kOhm	10% pos.log.variable resistor	XIC...	4	53.03.0166	IC-socket D1L 8 pin	
R...	526	.	10 kOhm	10% pos.log.variable resistor, see R525 St	XIC...	5	53.03.0166	IC-socket D1L 8 pin	
R...	527	.	10 kOhm	10% neg.log.variable resistor, see R525 St	XIC...	6	53.03.0166	IC-socket D1L 8 pin	
R...	528	57.11.4104	100 kOhm	5% 0.25W MF	XIC...	7	53.03.0166	IC-socket D1L 8 pin	
R...	529	57.11.4104	100 kOhm	5% 0.25W MF	XIC...	8	53.03.0166	IC-socket D1L 8 pin	
R...	530	57.11.4104	100 kOhm	5% 0.25W MF	XIC...	9	53.03.0166	IC-socket D1L 8 pin	
R...	531	57.11.4474	470 kOhm	5% 0.25W MF	XIC...	10	53.03.0166	IC-socket D1L 8 pin	
R...	532	57.11.4223	22 kOhm	5% 0.25W MF	XIC...	11	53.03.0166	IC-socket D1L 8 pin	
R...	533	57.11.4123	12 kOhm	5% 0.25W MF	XIC...	12	53.03.0166	IC-socket D1L 8 pin	
R...	534	57.11.4104	100 kOhm	5% 0.25W MF					
R...	535	57.11.4391	390 Ohm	5% 0.25W MF					
R...	536	57.11.4105	1 MOhm	5% 0.25W MF					
R...	537	57.11.4105	1 MOhm	5% 0.25W MF					
R...	538	57.11.4391	390 Ohm	5% 0.25W MF					
R...	539	57.11.4223	22 kOhm	5% 0.25W MF					
R...	540	57.11.4474	470 kOhm	5% 0.25W MF					
R...	541	57.11.4474	470 kOhm	5% 0.25W MF					
R...	542	57.11.4104	100 kOhm	5% 0.25W MF					
R...	543	57.11.4105	1 MOhm	5% 0.25W MF					
R...	544	57.11.6106	10 MOhm	10% 0.25W MF					
R...	545	57.11.4332	3.3 kOhm	2% 0.25W MF					
R...	546	57.11.4332	3.3 kOhm	2% 0.25W MF					
R...	547	57.11.4332	3.3 kOhm	2% 0.25W MF					
R...	548	57.11.4332	3.3 kOhm	2% 0.25W MF					
R...	590	.	4.3 kOhm	1% 0.25W MF (only for trafo input)					

CE=Ceramic, CF=Carbon Film, EL=Electrolytic, MF=Metal Film, PE=Polyester, PP=Polypropylen, PS=Polystyrol

MANUFACTURER: Ra=Raytheon, Six=Siliconix, St=Studer

1.912.514.00 COMPACT (HEX) DENSITY MONITOR WM 84.02.2400

KAPITEL 6: Einschub-Module des Meterpanels 1.913. ...

INHALT

1.	Bus Board	1.910.111
2.*	VU / PPM-Pegelmesser (30 LED)	1/2CH..... 1.913.101..
		4CH..... 1.913.321..
3.*	Bargraph-Pegelmesser (Gasplasma)	2CH..... 1.913.111/112
		8CH..... 1.913.411/412
4.	AUX-Pegelmesser.....	1.913.130
5.*	Gain Reduction Meter (Zeigerinstrument).....	1.913.132/134
6.	Signalisations-Anzeigeeinheit.....	1.913.140/141
7.	Test Generator.....	1.913.150
8.*	Kompressor/Limiter/Gate.....	1.913.155
9.*	Sammelschienenanwahl 9... 24 Kanäle.....	1.913.160... 167
10.*	Sammelschienenanwahl 1... 24 Kanäle.....	1.913.175... 178
11.	PFL-Verstärker	1.913.200
12.*	Korrelator 2CH/4CH	1.913.210/211
13.*	PPM-Zeigerinstrumente	1.913.220/221
14.*	VU-Zeigerinstrumente	1.913.230/231

SECTION 6: Plug-in Units of the meter panel 1.913. ...

CONTENTS

1.	Bus board	1.910.111
2.*	VU / PPM display (30 LED)	1/2CH..... 1.913.101..
		4CH..... 1.913.321..
3.*	Bargraph display (plasma)	2CH..... 1.913.111/112
		8CH..... 1.913.411/412
4.	AUX indicator.....	1.913.130
5.	Gain Reduction Meter (pointer instrument).....	1.913.132/134
6.	Signalization indication unit.....	1.913.140/141
7.	Audio generator.....	1.913.150
8.*	Compressor/limiter/gate	1.913.155
9.*	Bus selector 9... 24 channels	1.913.160... 167
10.*	Bus selector 1... 24 channels	1.913.175... 178
11.	PFL amplifier	1.913.200
12.*	Correlator 2CH/4CH.....	1.913.210/211
13.*	PPM (pointer instrument).....	1.913.220/221
14.*	VU meter (pointer instrument).....	1.913.230/231

- * Diese Beschreibungen werden kundenspezifisch bestückt.
 * These descriptions are supplied according to the customers requirements.

Distributor Board 1.910.111

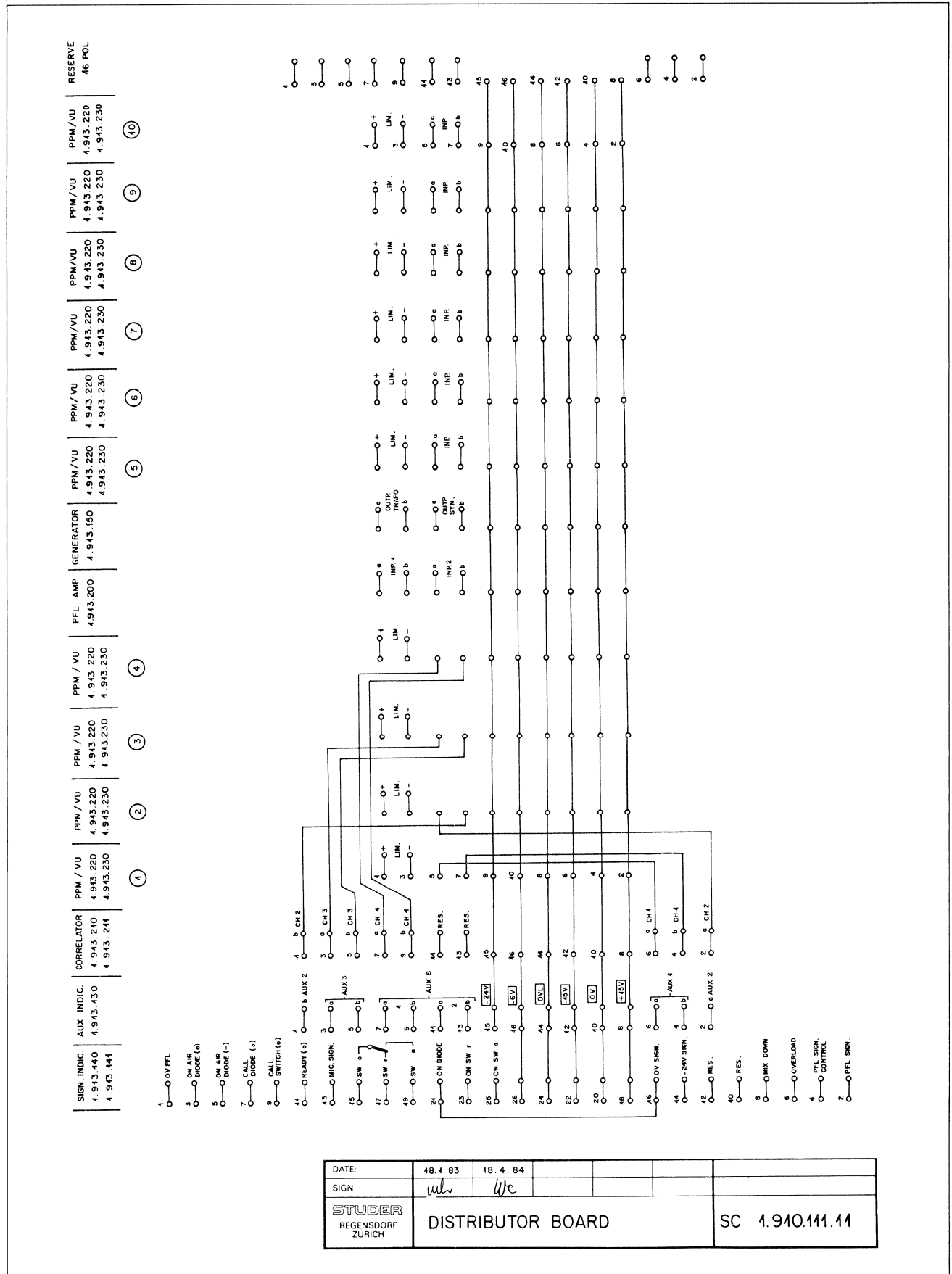

DATE:	18. 4. 83	18. 4. 84		
SIGN:	<i>W</i>	<i>W</i>		
STUDER REGENS DORF ZURICH	DISTRIBUTOR BOARD			SC 1.910.111.11

Distributor Board 1.910.111

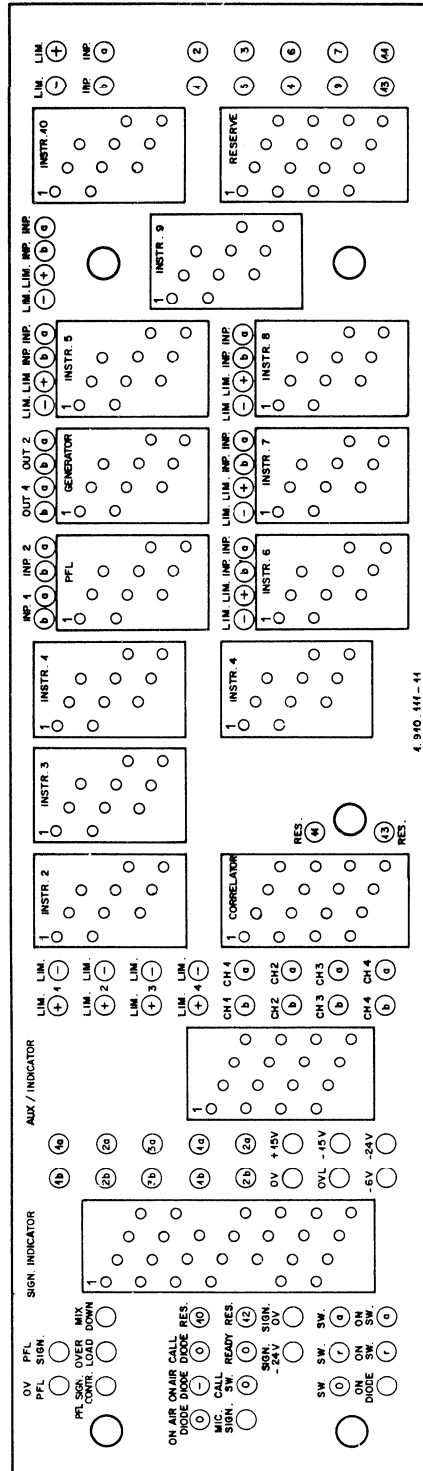

4.940.111-41

mh 18.1.83	AUDIO CONSOLE 900
STUDER	Distributor Board (Lötseite)
1.910.111 - 11	

Level meter VU/PPM 30 LED and gain reduction meter 10 LED

CONTENTS

Page

1.	General	2
2.	Functional description	3
3.	Technical data VU/PP meter	3
4.	Block diagram	4
5.	Alignment instruction VU/PP meter	4
6.	Maintenance instructions	5
7.	Gain reduction meter	6
8.	Diagrams	
	VU/PPM 30 LED	
	▪ Diagram	7
	▪ Component layout, position list	8
	Gain reduction meter	
	▪ Diagram	9
	▪ Component layout, position list	10

SCOPE OF VALIDITY

This manual applies to the following modules:

Display	1 Channel	2 Channels	4 Channels	PCB Nr.
PPM	1.913.101	1.913.105	1.913.321	1.913.295
VU	1.913.102	1.913.106	1.913.322	1.913.295
PPM / GRM	1.913.103	1.913.107	1.913.323	1.913.295/297
VU / GRM	1.913.104	1.913.108	1.913.324	1.913.295/297

1. General

The **STUDER output meter VU-PPM 30 LED** has been developed for installation into the display panel of STUDER mixing consoles. Instruments with VU (volume unit) or PPM (peak program meter) characteristic are available. In place of the bar indication, an optional dot indication is available.

The instruments listed below are equipped with the two PCBs 1.913.295 (VU/PPM) and 1.913.297 (GRM) corresponding to the table on page 1. The circuit diagram relating to the corresponding circuit board number should be consulted.

«Volume Unit Meters»

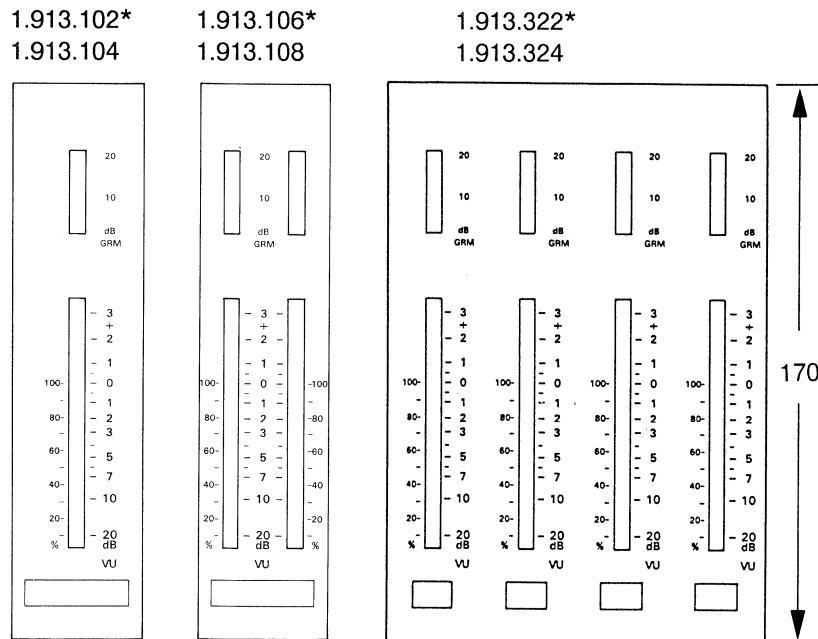

«Peak Program Meters»

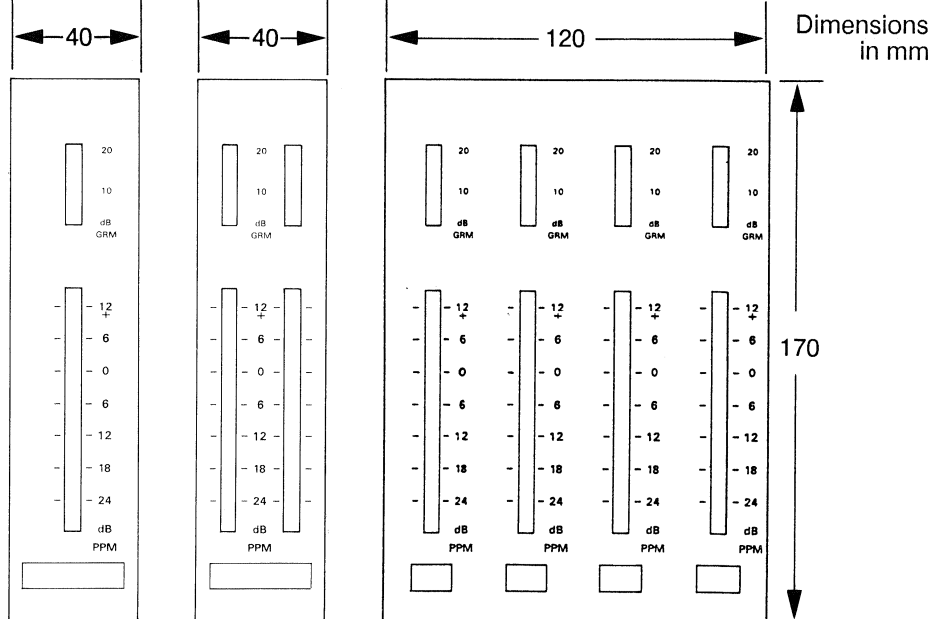

1.913.101*	1.913.105*	1.913.321*
1.913.103	1.913.107	1.913.323

* = Version without gain reduction meter (GRM)

2. Functional description

- PPM:** The peak program meter is a quasi-peak value instrument with a long release time. When a signal voltage corresponding to a level of 0 dB is applied for 10 ms, the resulting indication should be -1 dB. The desired decay time to -20dB is 1.7 s.
- VU-meter:** The VU-meter indicates signals according to the standard defined by ANSI 1954. When a signal with a duration of 300 ms is applied, the indication should be 99% of the reference value. The rise and decay time on the VU-meter are identical. The factory set lead is 6 dB.
- Gain reduction meter:** When the limiter/compressor is switched on, the GRM indicates the magnitude of the gain reduction.

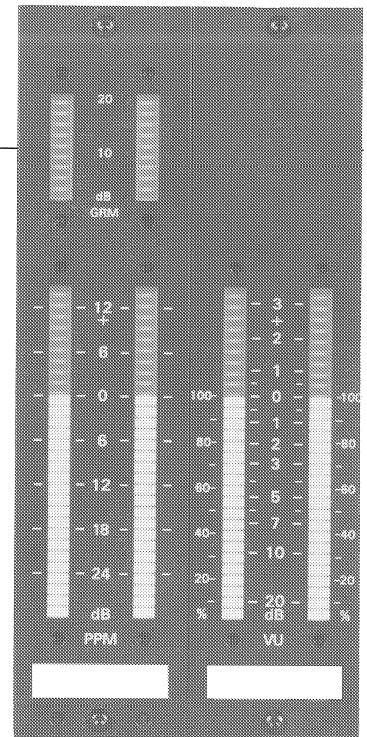

3. Technical data

General:

$$0 \text{ dBu} \hat{=} 0.775 V_{\text{eff}}$$

	Input sensitivity of the reference indication:	-1 dBu... +16 dBu
	Input impedance	> 10 k Ω
	Supply:	<u>DC \pm 15 V</u> or <u>DC +24 V</u>
	Current consumption: Quiescent	45mA / 35 mA
	Medium load	58mA / 56mA
	Full load	80mA / 80 mA
VU-meter:	Indicating range:	-20VU... +30VU
	Accuracy:	± 1 segment
	(precond.: -10VU... +3VU/0...50°C/31.5Hz...16kHz)	
	Response time to -1VU:	207(± 30)ms
PP-meter:	Indicating range:	-30dBu... +15dBu
	Accuracy:	± 1 segment
	(precond.: -30dB... +15dB/0...50°C/31.5Hz...16kHz)	
	Dynamic behavior:	
	Jumper normal: 0dB for 10 ms	\rightarrow indication: -1dB \pm 0.5dB
	Jumper normal: 0dB for 3ms	\rightarrow indication: -4dB \pm 1dB
	Jumper fast: 0dB for $\sim 100\mu$ s	\rightarrow indication: 1dB
	Decay time 0...-20dB:	1.7(± 0.3)s
Circuit board sizes:	Height x depth, with connector:	96 mm x 95 mm
	Width:	18 mm
	Center between M3 mounting holes:	85.1 mm (3.35")

4. Block diagram

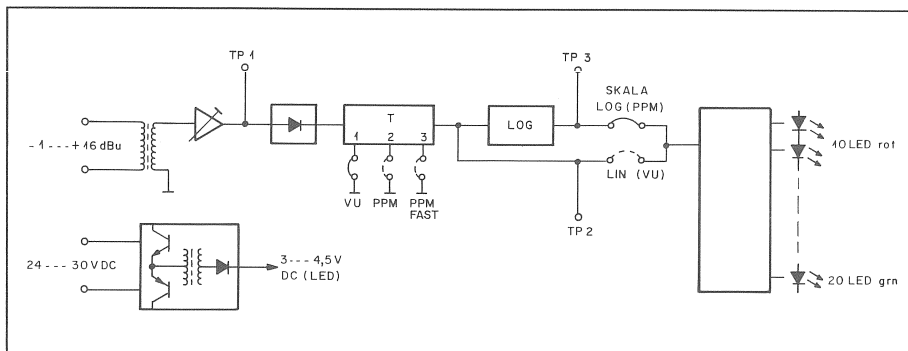

Fig. 2 VU-PPM block diagram: The settings VU/PPM/PPM fast or lin/log are established with the jumpers JS 1 and JS 2 respectively (see Fig. 3)

5. Alignment instructions VU/PP meter

PCB 1.913.295

Measuring instruments:

- AC voltmeter $R_i \geq 20 \text{ k}\Omega$
- DC voltmeter $R_i \geq 100 \text{ k}\Omega$, preferably digital VM
- Generator, 31.5Hz...16kHz, 0...16dBu; attenuator with 10dB increments.

Alignment elements

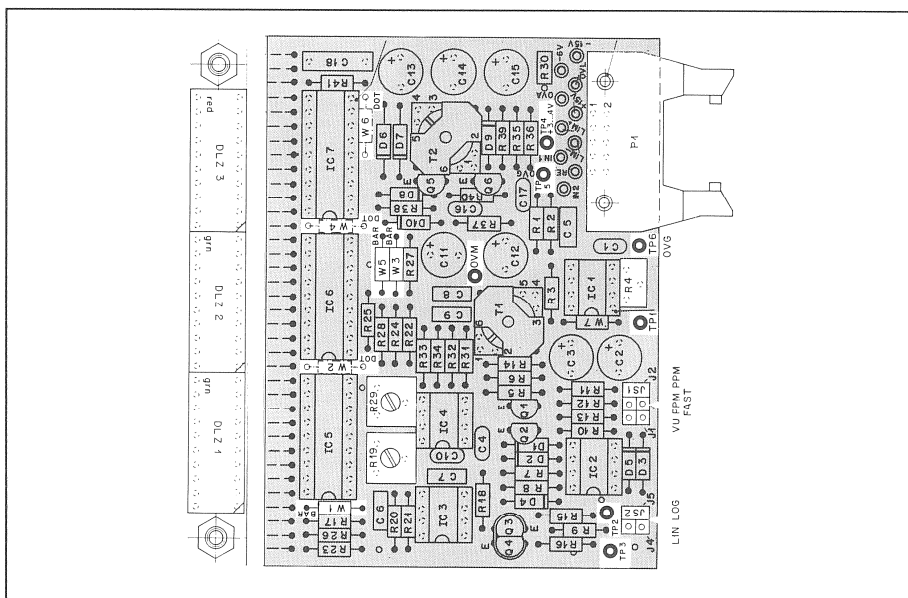

Fig. 3 Alignment elements of the VU/PPM 30 LED

Aligning the line level:

From the generator feed line level (-1dBu ... +16dBu) to the input. Align with R4 until all green LEDs are light and the red LEDs are still dark.
 [on TP3: 2.5(±0.1)V]

6. Maintenance instructions

PCB 1.913.295

Test input range: **Generator:** 1 kHz on input, level: -1dBu ... +16 dBu
AC VM: Hot to TP 1, cold to TP 6 (0V G)
 U_{TP1} adjustable with R4 to 290(±10)mV AC

Rectifier and indication: Both jumpers set to the VU/LIN position.
Generator: 1kHz with 0dBu level on input
 U_{TP1} : Adjust with R4 to 290(±2)mV AC. All green LEDs must be light.
DC VM: Hot to TP2, cold to TP6.
 $U_{TP2} = -380(±15)mV DC$
DC VM: Hot to TP3, cold to TP6
 $U_{TP3} = +2.575(±0.1)V DC$. All green LEDs are light.
Check: Adjust the generator level in such a way that:
 $U_{TP3} = +3.8(±0.1)V DC$. All diodes are light.
 $U_{TP3} = +0.17(±0.02)V DC$. Only the lowest green LED is light.

Logarithmation (PPM): Both jumpers are set to PPM/LOG.
Generator: 1kHz with +6dBu level on input.
 Set U_{TP2} with R4 to 1.18(±0.05V) DC.
 The two trimmers have the following basic setting:

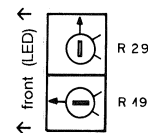
**Alignment procedure:**

DC VM: hot to TP3, cold to TP6.
A: Align the upper value with R19. Desired: $U_{TP3} = 3.06(±0.10)V$.
 All green LEDs and 4 red LEDs are light. Indication +6dB.
B: Attenuation by 30 dB with attenuator.
C: Align the lower value with R29. Desired: $U_{TP3} = 0.56(±0.02)V$.
 4 green LEDs are light. Indication -24 dB
 Repeat the procedure A → B → C → A → ... several times.

DC/DC converter: To check, connect the DC VM hot to TP4, cold to TP5. Generator with line level on input causes all green LEDs to light.
 Supply voltage: +24 V DC →TP4 = 3.1(±0.1)V
 +30 V DC →TP4 = 4.1(±0.1)V

7. Gain reduction meter

PCB 1.913.297

Connecting the GRM:

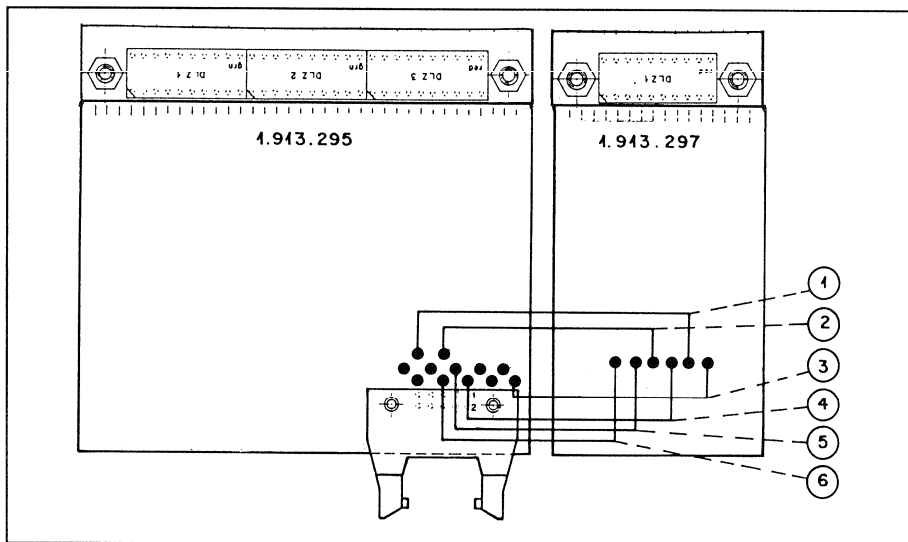

Fig. 4 Connection GRM - VU/PPM.

Conductor assignment of the connection cable:

	Color	Signal
1	yellow	0 VG
2	green	+3... +4,5 V
3	blue	- 15 V
4	red	+ 15 V
5	white	LIM +
6	grey	LIM -

Aligning the GRM:

- Limiter switched off
- Feed a test signal via an input channel. Set the level on the master output to nominal level + 20 dB.
- Switch on the limiter
- Align with R7 to a GRM indication of + 20 dB.

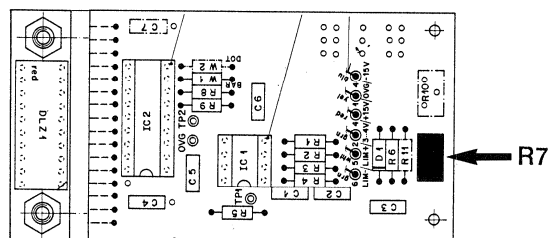

Technical data:

- Supply** The GRM indicator is supplied by the switching regulator of the basic unit 1.913.295: 24 ... 30 VDC.
- Current consumption:
 - quiescent 10mA
 - full load 25mA
- Indication** Voltage range:
 - min. control 0V ... +2V DC
 - max. control 0V ... +11V DC

- Circuit board dimensions:**
 - Height x depth: 45 mm x 85 mm
 - Width: 18 mm
 - Center between M3 mounting holes: 39.4 mm (1.55")

8. Diagrams / Schemata

VU- / PP - Meter 30 LED 1.913.295.00

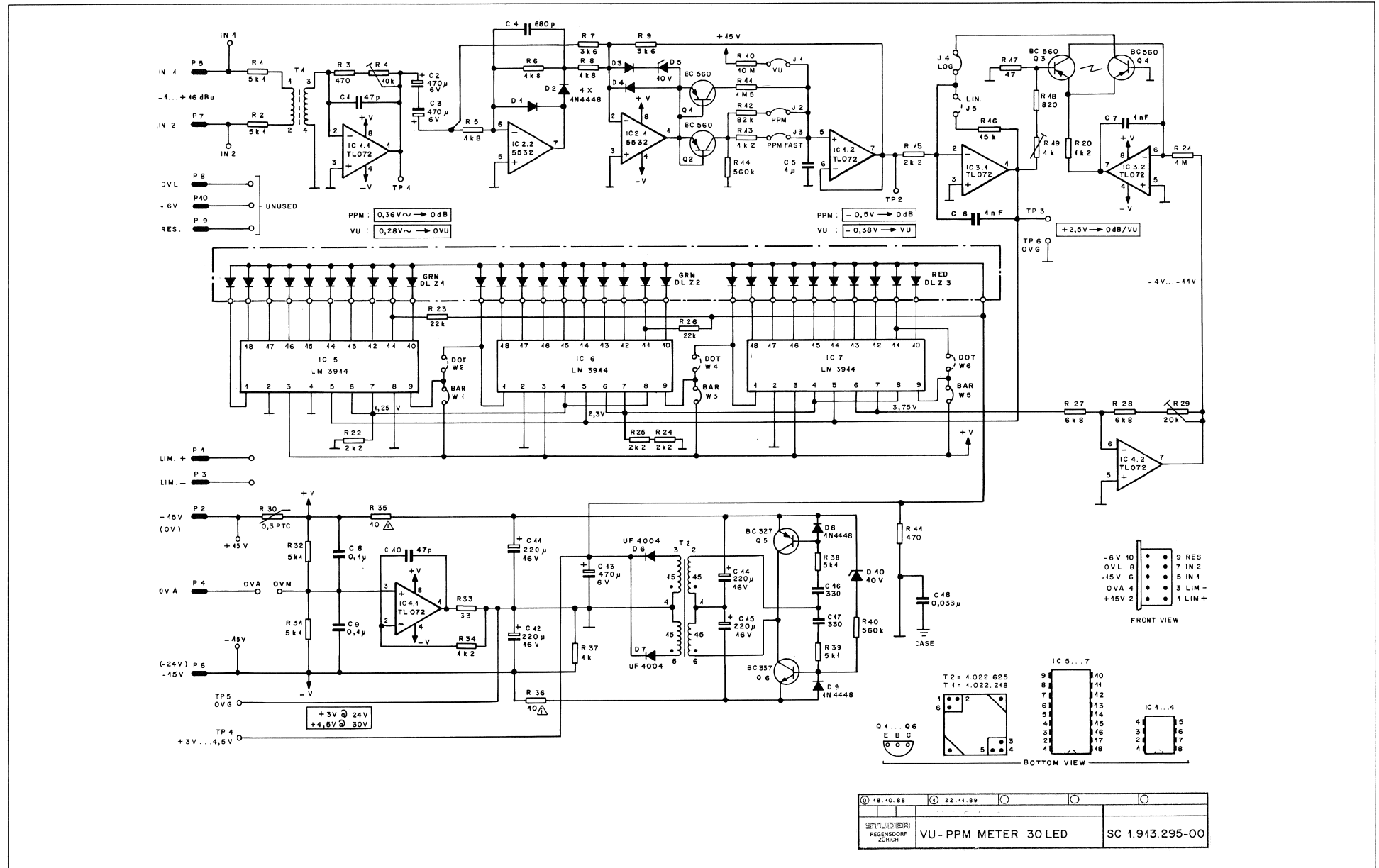

VU- / PP - Meter 30 LED 1.913.295.00

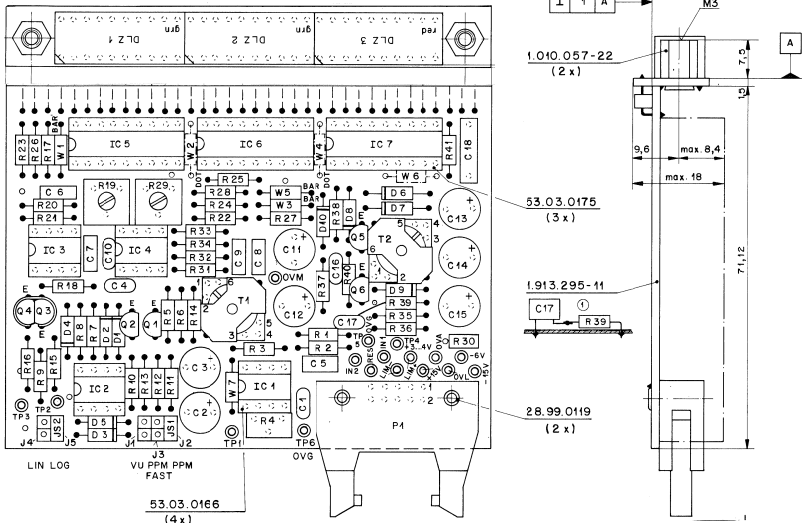

IND.	POS.NO.	PART NO.	VALUE	SPECIFICATIONS / EQUIVALENT	MANUF.
C...	01	59.34.2470	47 pF	CE	
C...	02	59.22.2471	470 pF	6V EL	
C...	03	59.22.2471	470 pF	6V EL	
C...	04	59.34.2481	680 pF	CE	
C...	05	59.06.5102	1 nF	SE	FE
C...	06	59.06.5102	1 nF	SE	FE
C...	07	59.06.0104	0.1 uF	FE	
C...	08	59.34.2470	47 pF	CE	
C...	09	59.22.4221	220 uF	16V EL	
C...	10	59.22.4221	220 uF	16V EL	
C...	11	59.22.4221	220 uF	16V EL	
C...	12	59.22.4221	220 uF	16V EL	
C...	13	59.22.4221	220 uF	16V EL	
C...	14	59.22.4221	220 uF	16V EL	
C...	15	59.34.4221	330 pF	SE	CE
C...	16	59.34.4221	330 pF	SE	CE
C...	17	59.34.4221	330 pF	SE	CE
C...	18	59.34.4221	330 pF	SE	CE
C...	19	59.31.4033	33 uF	400V	FE
D...	01	50.04.0125	186448	ST	any
D...	02	50.04.0125	186448	any	any
D...	03	50.04.0125	186448	any	any
D...	04	50.04.0125	186448	any	any
D...	05	50.04.1114	270 10	1/4 400V	any
D...	06	50.04.1114	270 10	1/4 400V	any
D...	07	50.04.1114	270 10	1/4 400V	any
D...	08	50.04.0125	186448	any	any
D...	09	50.04.0125	186448	any	any
D...	10	50.04.1114	270 10	1/4 400V	any
D...	11	50.04.2150	10 LED	DISPLAY GREEN	HP
D...	12	50.04.2150	10 LED	DISPLAY GREEN	HP
D...	13	50.04.2150	10 LED	DISPLAY RED	HP

S T U D E R (02) 89/11/22 FRI VU-PPM METER 30 LED PL 1.913.295.00 PAGE 1

IND.	POS.NO.	PART NO.	VALUE	SPECIFICATIONS / EQUIVALENT	MANUF.
IC...	01	50.09.0101	TL 072	4pin. opt. amp.	NS/TI
IC...	02	50.09.0105	NE5532	4pin. opt. amp. M	NS/Ra
IC...	03	50.09.0101	TL 072	4pin. opt. amp.	NS/TI
IC...	04	50.09.0101	TL 072	4pin. opt. amp.	NS/TI
IC...	05	50.11.0119	LM3915	14pin. bar/gat. lin.	NS
IC...	06	50.11.0119	LM3915	14pin. bar/gat. lin.	NS
IC...	07	50.11.0119	LM3915	14pin. bar/gat. lin.	NS
JP...	01	54.01.0020		2 pin plus	
JP...	02	54.01.0020		2 pin plus	
JP...	03	54.01.0020		2 pin plus	
JP...	04	54.01.0020		2 pin plus	
JP...	05	54.01.0020		2 pin plus	
JS...	01	54.01.0021		2pin	
JS...	02	54.01.0021		2pin	
MF...	01	1.913.295-11		1 pin VU-PPM Meter 30 LED PCB	St
MF...	02	1.010.057-22		2 pin Hexagon post #347.2	
MF...	03	50.09.0119		2 pin linear driver P 2.5 x 4.0	
MF...	04	50.03.0662		4 pin 8-pin IC socket	
MF...	05	53.03.0175		1 pin 10-pin IC socket	
MF...	06	54.11.0132		36 pin connector	
MF...	07	54.02.0771		17 pin plus (6 Bund - Stecktitel)	
MF...	08	50.20.2001		1 pin clip	
P...	01	54.14.2011		24 pin pcb connector for ribbon cable	
R...	01	50.03.0496	RC 560	FRF	any
R...	02	50.03.0496	RC 560	FRF	any
R...	03	50.03.0496	RC 560	FRF Typ C, beta 290-370	Ph,SI
R...	04	50.03.0496	RC 560	FRF Typ C, beta 290-370	Ph,SI
R...	05	50.03.0351	RC 327	-25 FRF -BA	any
R...	06	50.03.0350	RC 327	-25 FRF -BA	any
R...	01	57.11.3512	5.1 kOhm	1% 0.25W	
R...	02	57.11.3512	5.1 kOhm	1% 0.25W	

S T U D E R (02) 89/11/22 FRI VU-PPM METER 30 LED PL 1.913.295.00 PAGE 2

IND.	POS.NO.	PART NO.	VALUE	SPECIFICATIONS / EQUIVALENT	MANUF.
R...	03	57.11.3481	680 Ohm	0.25W	
R...	04	57.11.3471	470 Ohm	0.25W	
R...	05	58.01.9103	10 kOhm	10% 0.50W trim	
R...	06	57.11.3182	1.8 kOhm	1% 0.25W	
R...	07	57.11.3182	1.8 kOhm	1% 0.25W	
R...	08	57.11.3182	1.8 kOhm	1% 0.25W	
R...	09	57.11.3182	1.8 kOhm	1% 0.25W	
R...	10	57.11.3182	1.8 kOhm	1% 0.25W	
R...	11	57.11.5106	10 kOhm	10% 0.25W	
R...	12	57.11.5106	10 kOhm	10% 0.25W	
R...	13	57.11.5106	10 kOhm	10% 0.25W	
R...	14	57.11.3223	2.2 kOhm	1% 0.25W	
R...	15	57.11.3223	2.2 kOhm	1% 0.25W	
R...	16	57.11.3223	2.2 kOhm	1% 0.25W	
R...	17	57.11.3223	2.2 kOhm	1% 0.25W	
R...	18	57.11.3223	2.2 kOhm	1% 0.25W	
R...	19	57.11.3223	2.2 kOhm	1% 0.25W	
R...	20	57.11.3223	2.2 kOhm	1% 0.25W	
R...	21	57.11.3223	2.2 kOhm	1% 0.25W	
R...	22	57.11.3223	2.2 kOhm	1% 0.25W	
R...	23	57.11.3223	2.2 kOhm	1% 0.25W	
R...	24	57.11.3223	2.2 kOhm	1% 0.25W	
R...	25	57.11.3223	2.2 kOhm	1% 0.25W	
R...	26	57.11.3223	2.2 kOhm	1% 0.25W	
R...	27	57.11.3223	2.2 kOhm	1% 0.25W	
R...	28	57.11.3223	2.2 kOhm	1% 0.25W	
R...	29	57.11.3223	2.2 kOhm	1% 0.25W	
R...	30	57.11.3223	2.2 kOhm	1% 0.25W	
R...	31	57.11.3223	2.2 kOhm	1% 0.25W	
R...	32	57.11.3223	2.2 kOhm	1% 0.25W	
R...	33	57.11.3223	2.2 kOhm	1% 0.25W	
R...	34	57.11.3223	2.2 kOhm	1% 0.25W	
R...	35	57.15.0100	10 Ohm	0.25W	
R...	36	57.15.0100	10 Ohm	0.25W	
R...	37	57.11.3122	1.2 kOhm	0.25W	

S T U D E R (02) 89/11/22 FRI VU-PPM METER 30 LED PL 1.913.295.00 PAGE 3

Gain Reduction Meter 1.913.297.00

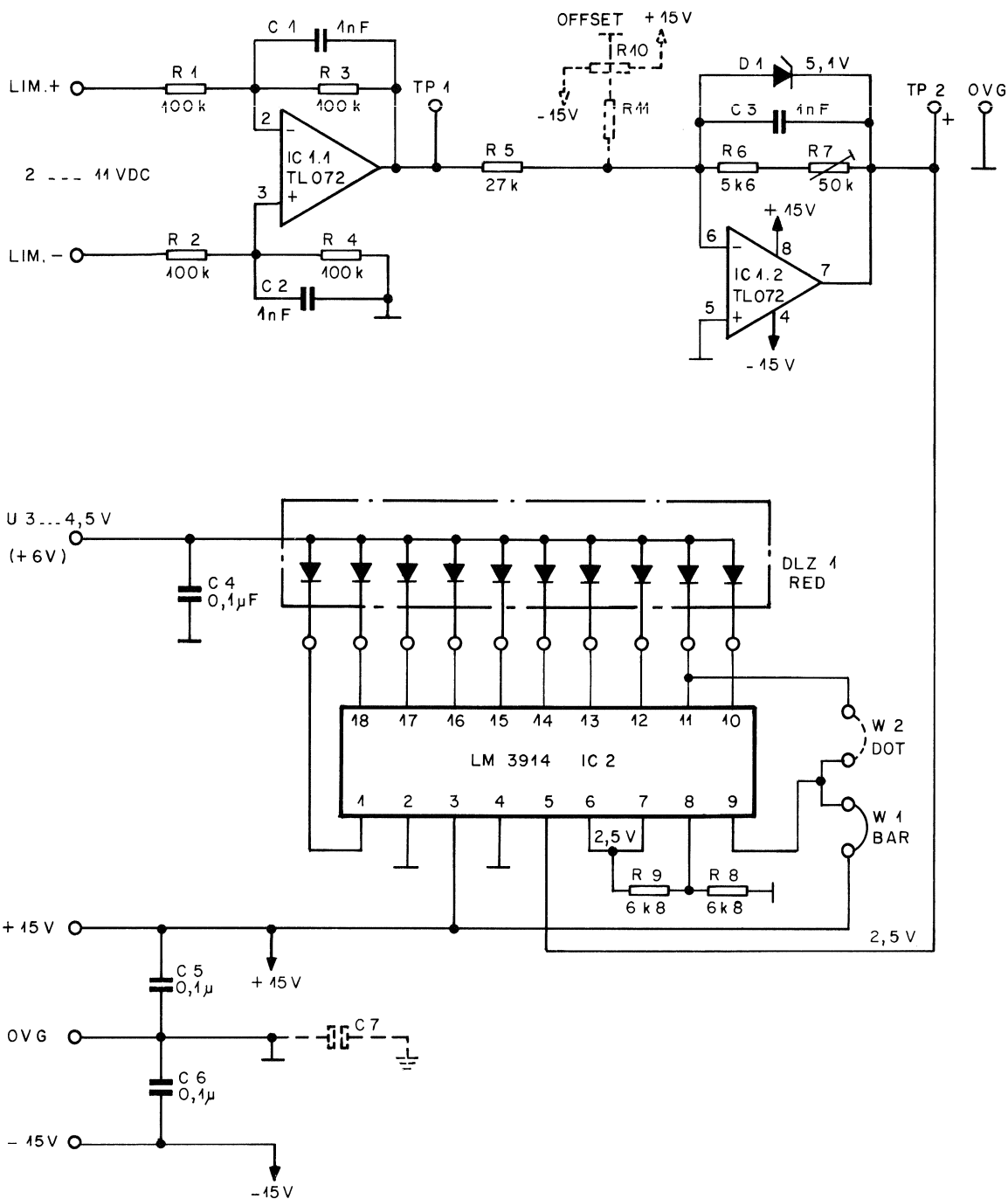

SPECIFICATIONS : UNIT WILL SUPPLIED BY VU/PPM METER 1.913.295.00 / 24V...30V
 CURRENT WILL INCREASE BY → IDLE : 10mA / LOAD : 25mA

© 13.11.89			
STUDER REGENSDORF ZÜRICH	GRM METER 10 LED	SC 1.913.297.00	

VU / PPM 30 LED

Gain Reduction Meter 1.913.297.00

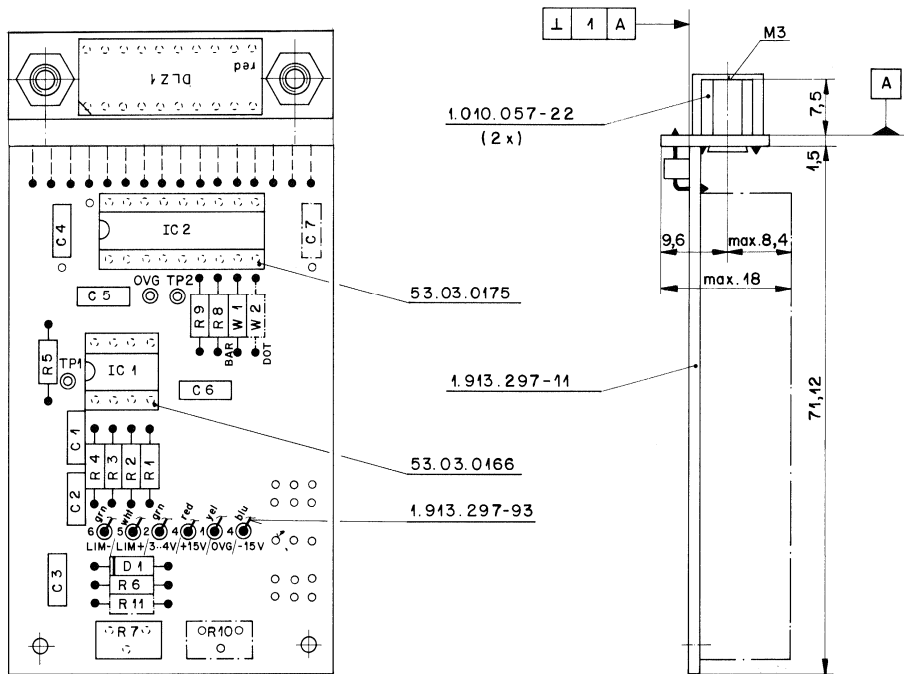

Schilder 1.913.297-04 / 43.01.0108
aufgeklebt nach Fabrikationsmuster.

IND.	POS.NO.	PART NO.	VALUE	SPECIFICATIONS / EQUIVALENT	MANUF.	IND.	POS.NO.	PART NO.	VALUE	SPECIFICATIONS / EQUIVALENT	MANUF.
C...	01	59.06.5102	1 nF	5% PE							
C...	02	59.06.5102	1 nF	5% PE							
C...	03	59.06.5102	1 nF	5% PE							
C...	04	59.06.0104	0.1 uF	PE							
C...	05	59.06.0104	0.1 uF	PE							
C...	06	59.06.0104	0.1 uF	PE							
D...	01	50.04.1112	ZPD 5.1	V 5W 5.1V SI	any						
DLZ...	01	50.04.2150	10 LED	DISPLAY RED	HP						
IC...	01	50.09.0101	TL 072	dual op. amp.	NS, TI						
IC...	02	50.11.0119	LM3914	led bar/dot lin.	NS						
MP...	01	1.913.297.11	1 pcs	GRM METER 10 LED PCB	St						
MF...	02	1.010.057.22	2 pcs	Hexagon post NSM7.4							
MF...	03	53.03.0166	1 pcs	8-pin IC-socket							
MF...	04	53.03.0175	1 pcs	18-pin IC-socket							
MF...	05	54.11.0132	16 pcs	connection							
MF...	06	54.02.0471	9 pcs	plug (Rund - Steckstift)							
MF...	07	1.913.297.93	Li-Li	6 cable connections	St						
R...	01	57.11.3104	100 kOhm	1% 0.25W							
R...	02	57.11.3104	100 kOhm	1% 0.25W							
R...	03	57.11.3104	100 kOhm	1% 0.25W							
R...	04	57.11.3104	100 kOhm	1% 0.25W							
(00) R...	05	57.11.3473	47 kOhm	0.25W							
(01) R...	05	57.11.3273	27 kOhm	0.25W							
(00) R...	06	57.11.3103	10 kOhm	0.25W							
(00) R...	06	57.11.3562	5.6 kOhm	0.25W							
R...	07	58.01.9503	50 kOhm	10% 0.50W trim							
R...	08	57.11.3682	6.8 kOhm	1% 0.25W							
R...	09	57.11.3682	6.8 kOhm	1% 0.25W							
W...	01	57.11.3000		Wire link BAR, W2 DOT							

ORIG 88/10/31 (01) 89/11/22

VU/PPM LED Level Meter Modules

Contents

1 General 2

2 Functional Description 3

3 Technical Specifications..... 3

4 Block Diagram 4

5 Alignment..... 4

Diagrams	PCB No.	Diagram	Component Layout	Parts List
VU/PPM 30 LED with GRM	1.913.293.00	1.913.293.00	1.913.293.00	1.913.293.00
VU/PPM 30 LED	1.913.294.00			1.913.294.00
LED PPM Meter (10 LED)	1.913.291.00	1.913.291.00	1.913.291.00	1.913.291.00

Scope of Validity

These instructions apply to the following assemblies:

Display	1 Channel, dark front panel	2 Channels, dark front panel	2 Channels, bright front panel	4 Channels, dark front panel	PCB No.
PPM	1.913.101	1.913.105	1.913.605	1.913.321	1.913.294
VU	1.913.102	1.913.106	1.913.606	1.913.322	1.913.294
PPM w. GRM	1.913.103	1.913.107	-	1.913.323	1.913.293
VU w. GRM	1.913.104	1.913.108	-	1.913.324	1.913.293
PPM w. additional small level meter	-	-	1.913.610	-	1.913.294, 1.913.291

1 General

The Level Meter units with 30 LEDs have been developed for installation in the display panel of Studer Mixing Consoles. Instruments with VU (volume unit) and PPM (peak program meter) characteristics, with or without gain reduction meter (GRM) are available. Instead of bar-graph indication, also dot indication is optionally available.

The instruments listed below are equipped with the PCBs 1.913.294 (VU or PPM) or 1.913.293 (VU or PPM with gain reduction meter) according to the table above. Please consult the circuit diagram relating to the corresponding assembly number.

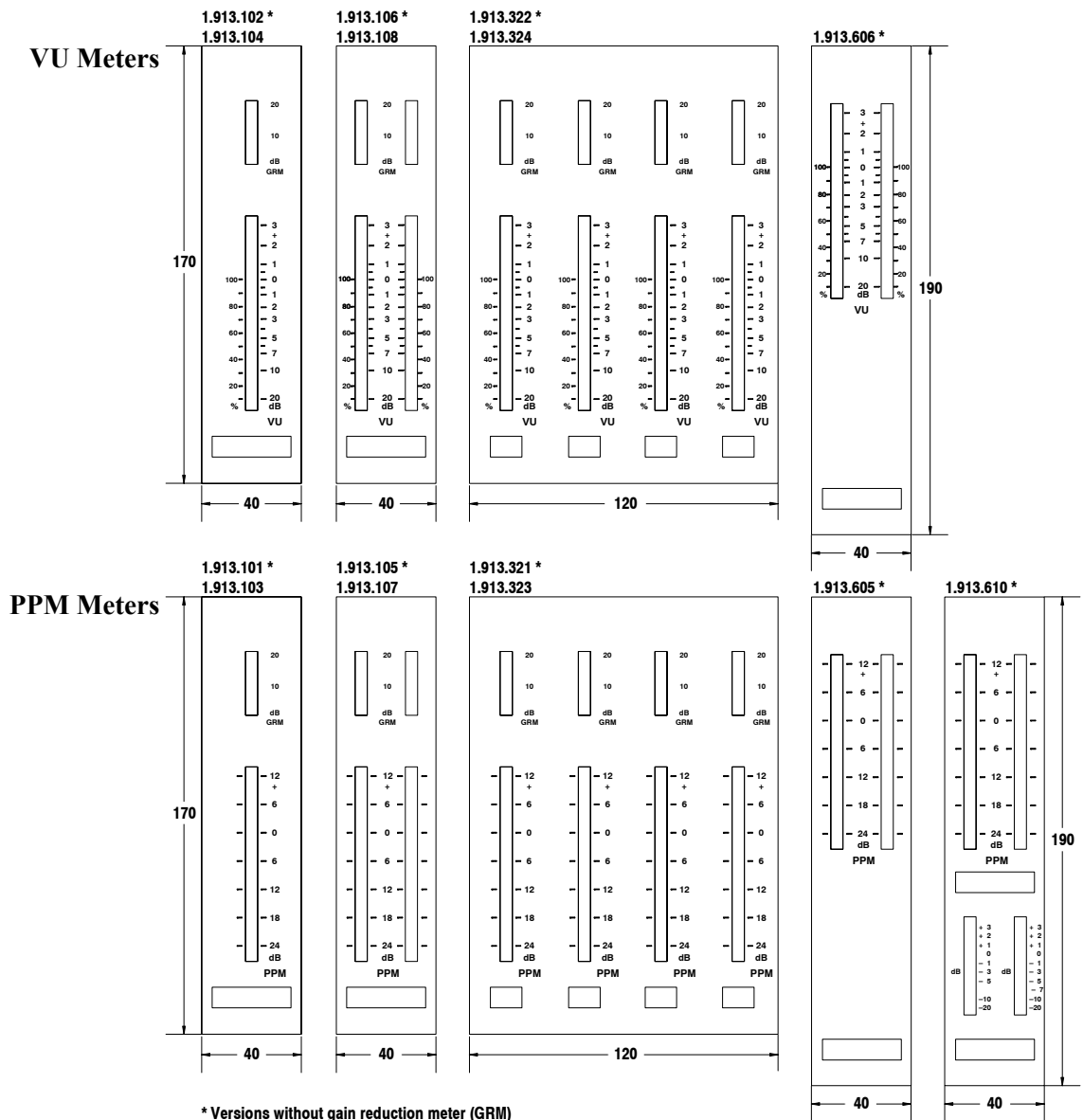

2 Functional Description

- PPM:** The peak program meter is a quasi-peak value instrument with long decay time. When a signal voltage corresponding to a level of 0 dB is applied for 10 ms, the resulting indication is -1 dB. Decay time (0 to -20 dB) is 1.7 s.
- VU Meter:** The VU meter indicates signals according to the standard defined by ANSI 1954. When a signal with a duration of 300 ms is applied, the indication is 99% of the reference value. Rise and decay times on a VU meter are identical. The factory-set lead is +6 dB.
- Gain Reduction Meter:** When the limiter/compressor is switched on, the GRM indicates the magnitude of the gain reduction.
- Small PPM:** The assembly 1.913.610 contains an additional small PPM meter with 10 LEDs, normally used for AUX level indication.
- Bar/Dot Display Selection:** On each of the PCBs, selection of bar or dot display mode is provided. All level meters are factory-set to bar display mode; dot display mode is unusual and recommended only if extra-low current consumption is required.

PCB No.	Bar Display Mode (Default Factory Setting)	Dot Display Mode
1.913.293.00 (VU/PPM 30 LED w. GRM)	insert: R3, R8, R10, R15 remove: R4, R9, R11, R14	insert: R4, R9, R11, R14 remove: R3, R8, R10, R15
1.913.294.00 (VU/PPM 30 LED)	insert: R3, R8, R10 remove: R4, R9, R11	insert: R4, R9, R11 remove: R3, R8, R10
1.913.291.00 (PPM 10 LED)	insert jumper JS201	remove jumper JS201

3 Technical Specifications

General:	0 dBu \pm 0.775 V _{rms}		
	Sensitivity for reference indication	-1 dBu ... +16 dBu	
Input impedance	>10 k Ω		
Supply		\pm 15 V _{DC}	+24 V _{DC}
Current consumption without GRM (p. ch., bar display mode)	Quiescent:	45 mA	35 mA
	Full load:	80 mA	80 mA
Current consumption with GRM (p. ch., bar display mode)	Quiescent:	55 mA	45 mA
	Full load:	105 mA	105 mA
VU Meter (1.913.293):	Indication range	-20 VU ... +3 VU	
	Accuracy (conditions: -10...+3 VU, 0...+50° C, 31.5 Hz...16 kHz)	\pm 1 segment	
	Response time to -1 VU	207 ms \pm 30 ms	
PPM (1.913.293):	Indication range	-30 dBu ... +15 dBu	
	Accuracy (conditions: -30...+15 VU, 0...+50° C, 31.5 Hz...16 kHz)	\pm 1 segment	
	Dynamic behavior		
	Jumper "normal" 0 dB, 10 ms burst	Indication:	-1 dB \pm 0.5 dB
	0 dB, 3 ms burst	Indication:	-4 dB \pm 1 dB
	Jumper "fast" 0 dB, 100 μ s burst	Indication:	-1 dB
Decay time: 0...-20 dB	1.7 s \pm 0.3 s		
GRM (1.913.294):	Input voltage range	min. control: 0 V ... +2 V _{DC}	
		max. control: 0 V ... +11 V _{DC}	
Dimensions:	1- and 2-channel units, dark front panel (w x h x d)		40 x 170 x 97 mm
	2-channel units, bright front panel (w x h x d)		40 x 190 x 97 mm
	4-channel units, dark front panel (w x h x d)		120 x 170 x 97 mm

4 VU/PPM Meter Block Diagram

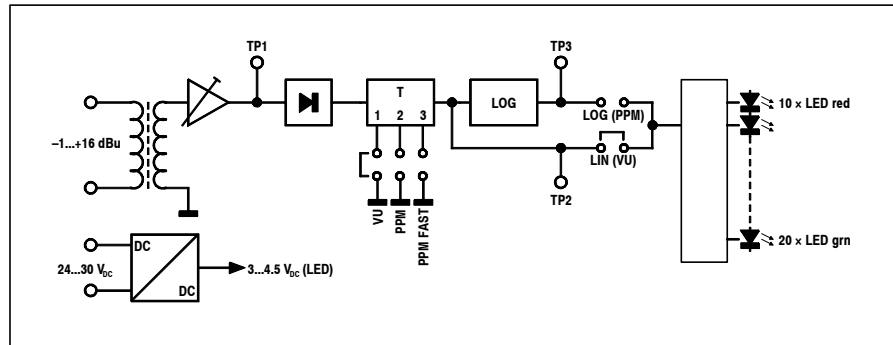

VU/PPM meter block diagram: VU/PPM/PPM FAST and LIN/LOG settings are established with jumpers J2 and J3, respectively.

5 Alignment

Required Instruments: AC voltmeter, $R_i \geq 20 \text{ k}\Omega$
 DC voltmeter, $R_i \geq 100 \text{ k}\Omega$
 AF generator, 31.5 Hz ... 16 kHz, 0...16 dBu; attenuator with 10 dB increments.

DC/DC Converter Check: Connect DC voltmeter to TP5 (hot) and TP4 (ground). Feed generator output signal with line level (-1...+16 dBu) to the input (pins 5 and 7 of P1, or TP8 and TP9); all green LEDs are on.
 DC voltmeter reading should be:
 $3.1 \pm 0.1 \text{ V}_{\text{DC}}$ (supply: +24 V_{DC}),
 $4.1 \pm 0.1 \text{ V}_{\text{DC}}$ (supply: +30 V_{DC}).

Input Range: Feed generator output signal with line level (1 kHz, -1...+16 dBu) to the input (pins 5 and 7 of P1, or TP8 and TP9).
 Connect AC voltmeter to test points TP1 (hot) and TP4 (ground). Reading must be adjustable with RA3 to $290 \pm 10 \text{ mV}_{\text{AC}}$ for the complete input level range.

Line Level: Feed generator output signal with your line level (1 kHz, range: -1...+16 dBu) to the input (pins 5 and 7 of P1, or TP8 and TP9).
 Adjust RA3 until all green LEDs are on. The red LEDs must be dark.
 (TP3: $2.5 \pm 0.1 \text{ V}_{\text{DC}}$).

Rectifier and Indication: Set J2 to VU, J3 to LIN.
 Feed generator output signal with your line level (1 kHz, usually 0 dBu) to the input (pins 5 and 7 of P1, or TP8 and TP9).
 Connect AC voltmeter to test points TP1 (hot) and TP4 (ground). Adjust with RA3 to $290 \pm 10 \text{ mV}_{\text{AC}}$. All green LEDs must be on.
 Connect DC voltmeter to test points TP2 (hot) and TP4 (ground); the meter should read $-380 \pm 15 \text{ mV}_{\text{DC}}$.
 Connect DC voltmeter to test points TP3 (hot) and TP4 (ground); the meter should read $+2.575 \pm 0.100 \text{ V}_{\text{DC}}$. All green LEDs must be on.
Check: Set generator output for a DC voltmeter reading of $3.8 \pm 0.1 \text{ V}_{\text{DC}}$. All LEDs must be on. Set generator output for a DC voltmeter reading of $170 \pm 20 \text{ mV}_{\text{DC}}$. Only the lowest LED must be on.

Log Converter (PPM only): Set J2 to PPM, J3 to LOG.
 Feed generator output signal (1 kHz, +6 dBu) to the input (pins 5 and 7 of P1, or TP8 and TP9).
 Connect DC voltmeter to test points TP2 (hot) and TP4 (ground). Adjust with RA3 to $1.18 \pm 0.05 V_{DC}$.
 RA1 and RA2: Basic setting according to the arrows in the diagram below.
 Procedure:

1. Upper value setting: Adjust with RA2 to $3.06 \pm 0.10 V_{DC}$. All green LEDs and four red LEDs must be on (+6 dB indication).
2. Set generator output to -24 dBu (i.e., attenuate the +6 dBu setting from above by 30 dB).
3. Lower value setting: Adjust with RA1 to $560 \pm 20 mV_{DC}$. Only the four lowest green LEDs must be on (-24 dB indication).
4. These two settings are interdependent, therefore repeat steps 1...3 several times.

GRM (if included): Connect the Meter Unit to the console.
 Feed a test signal via an input channel. Set the level on the master output to nominal level +20 dB.
 Switch the limiter on.
 Align with RA4 to a GRM indication of 20 dB.

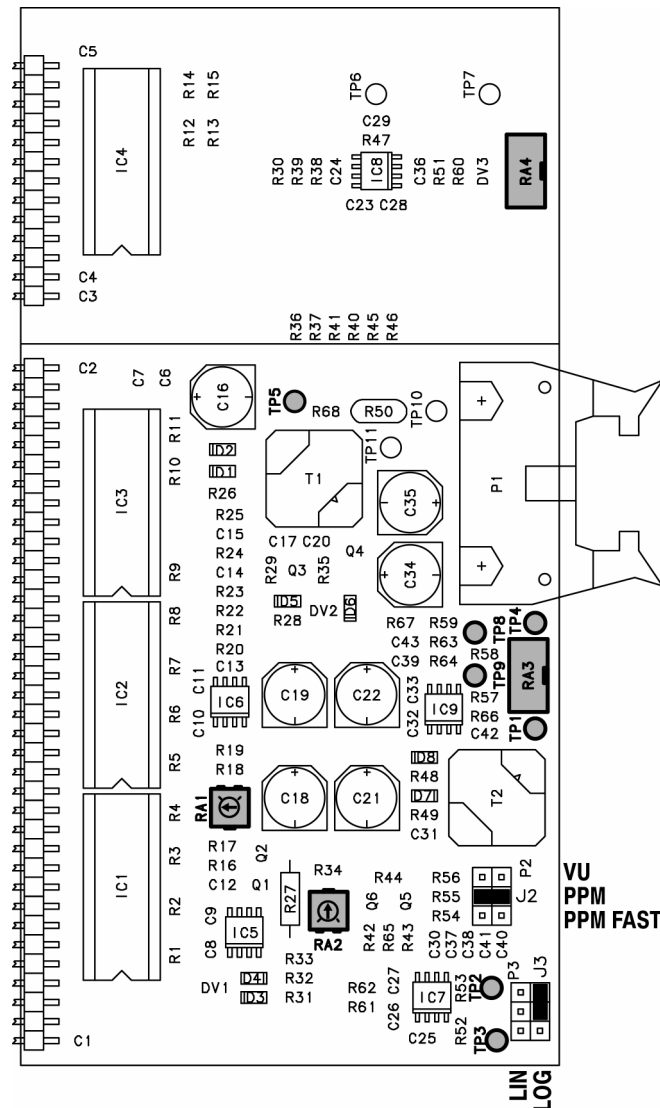

Line Level for 1.913.291: Feed generator output signal with your line level (1 kHz, range: +6...+15 dBu) to the input (pins 5 and 7 of P201, or TP5 and TP4). Adjust R204 until all green LEDs are on. The red LEDs must be dark.

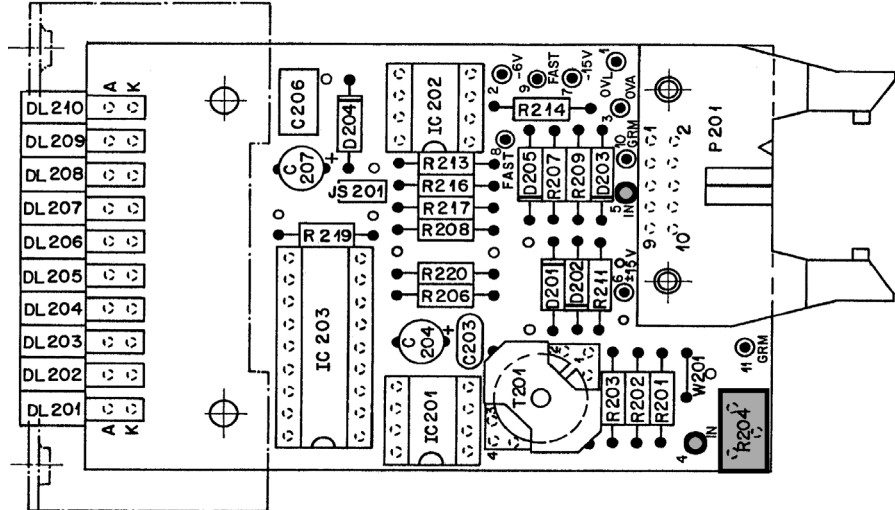

VU/PPM/GRM Meter 1.913.293.00

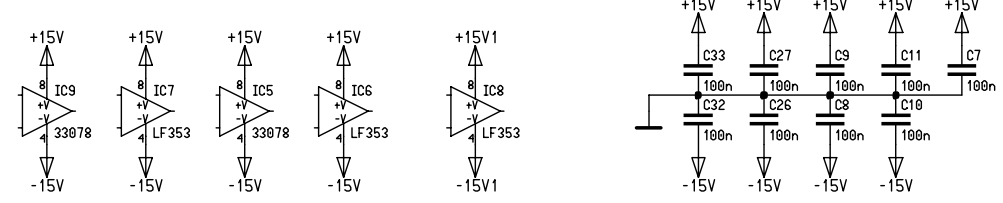
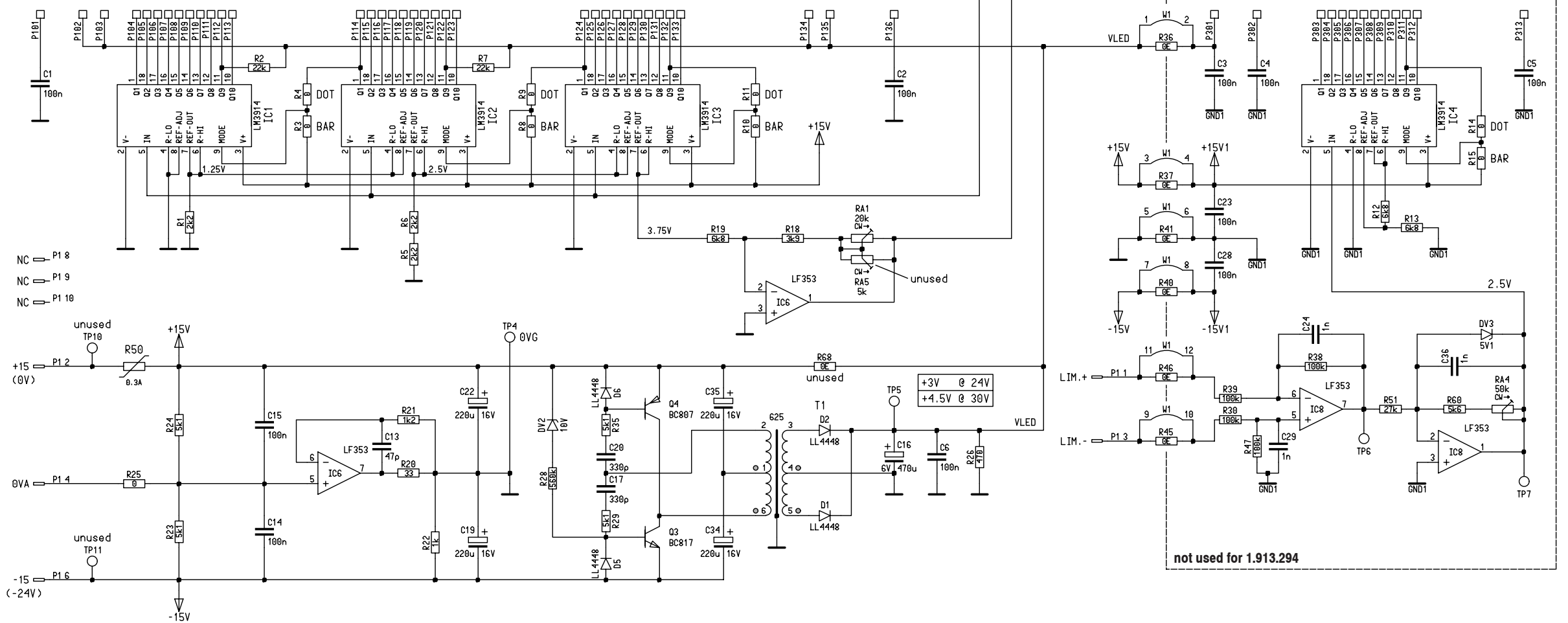
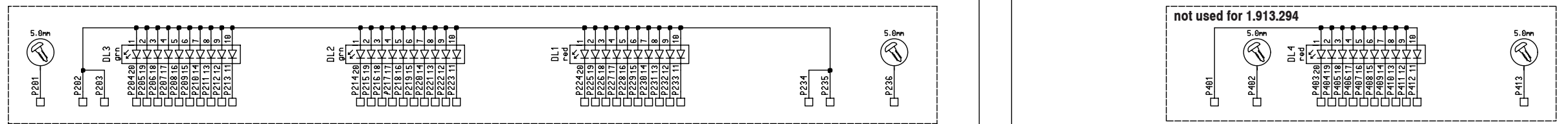
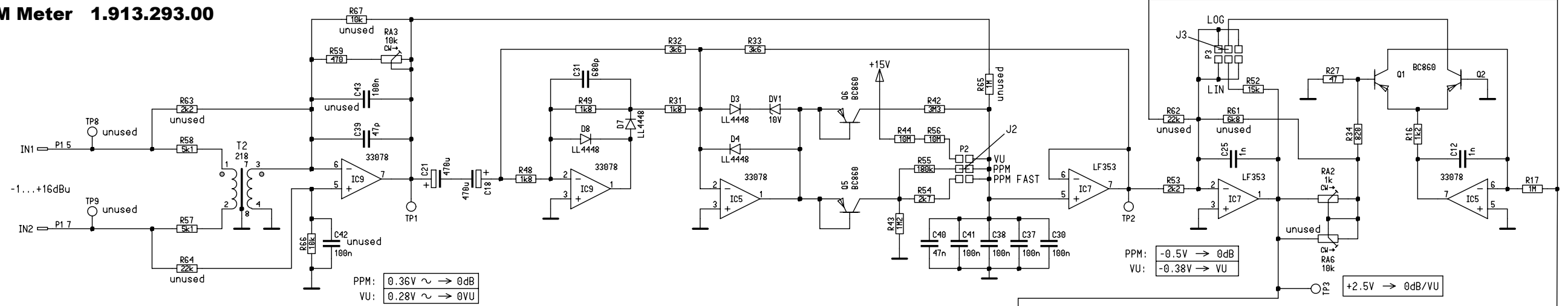

Erstellt	29.10.2001	ZT	29.01.2002	ZT					
STUDER									
VU/PPM/GRM METER					SC		1.913.293.00		
PAGE 1 OF 1									

VU/PPM/GRM Meter 1.913.293.00

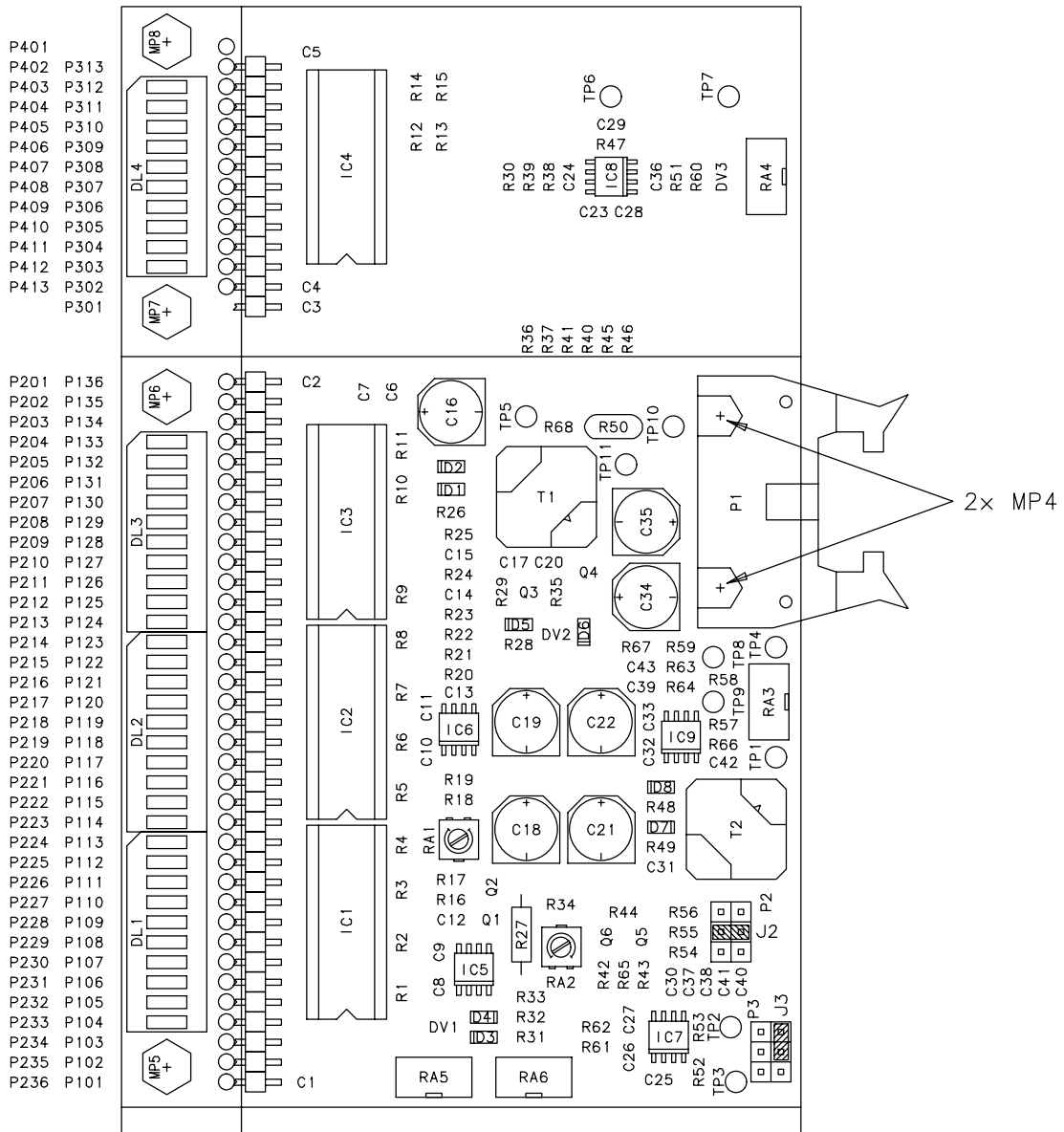
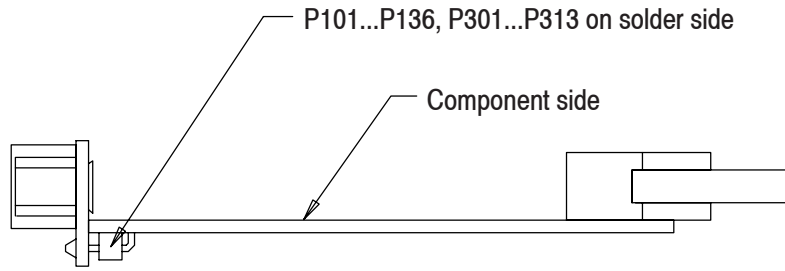

Accompanying documents: Zugehörige Unterlagen: PL	General tolerance: Freimasstoleranz:	Scale: Massstab: 1:1	Edition Ausgabe 29.10.2001	ZT	ML	HW	⊙
Substitute for: Ersatz fuer:			Date Datum	Visa Gez.	Checked Gepr.	Seen Ges.	Index
STUDER REGENSDORF	Description: Benennung: VU/PPM/GRM METER , ESE	Z	Page: Seite: 1 / 1	Number: Number: 1.913.293.00			

VU/PPM/GRM Meter 1.913.293.00 (4)

Idx. Pos.	Part No.	Qty.	Type/Val.	Description	Idx. Pos.	Part No.	Qty.	Type/Val.	Description
0 C 1	59.60.3337	1 pce	100n	CER 50V, 10%, X7R, 0805	0 P 124	54.11.0125	1 pce	1p	Pin, 1reihig, winkel
0 C 2	59.60.3337	1 pce	100n	CER 50V, 10%, X7R, 0805	0 P 125	54.11.0125	1 pce	1p	Pin, 1reihig, winkel
0 C 3	59.60.3337	1 pce	100n	CER 50V, 10%, X7R, 0805	0 P 126	54.11.0125	1 pce	1p	Pin, 1reihig, winkel
0 C 4	59.60.3337	1 pce	100n	CER 50V, 10%, X7R, 0805	0 P 127	54.11.0125	1 pce	1p	Pin, 1reihig, winkel
0 C 5	59.60.3337	1 pce	100n	CER 50V, 10%, X7R, 0805	0 P 128	54.11.0125	1 pce	1p	Pin, 1reihig, winkel
0 C 6	59.60.3337	1 pce	100n	CER 50V, 10%, X7R, 0805	0 P 129	54.11.0125	1 pce	1p	Pin, 1reihig, winkel
0 C 7	59.60.3337	1 pce	100n	CER 50V, 10%, X7R, 0805	0 P 130	54.11.0125	1 pce	1p	Pin, 1reihig, winkel
0 C 8	59.60.3337	1 pce	100n	CER 50V, 10%, X7R, 0805	0 P 131	54.11.0125	1 pce	1p	Pin, 1reihig, winkel
0 C 9	59.60.3337	1 pce	100n	CER 50V, 10%, X7R, 0805	0 P 132	54.11.0125	1 pce	1p	Pin, 1reihig, winkel
0 C 10	59.60.3337	1 pce	100n	CER 50V, 10%, X7R, 0805	0 P 133	54.11.0125	1 pce	1p	Pin, 1reihig, winkel
0 C 11	59.60.3337	1 pce	100n	CER 50V, 10%, X7R, 0805	0 P 134	54.11.0125	1 pce	1p	Pin, 1reihig, winkel
0 C 12	59.60.2373	1 pce	1n0	CER 50V, 5%, COG, 0805	0 P 135	54.11.0125	1 pce	1p	Pin, 1reihig, winkel
0 C 13	59.60.2241	1 pce	47p	CER 50V, 5%, COG, 0603	0 P 136	54.11.0125	1 pce	1p	Pin, 1reihig, winkel
0 C 14	59.60.3337	1 pce	100n	CER 50V, 10%, X7R, 0805	0 P 301	54.11.0125	1 pce	1p	Pin, 1reihig, winkel
0 C 15	59.60.3337	1 pce	100n	CER 50V, 10%, X7R, 0805	0 P 302	54.11.0125	1 pce	1p	Pin, 1reihig, winkel
0 C 16	59.68.0033	1 pce	470u	EL 6V, 8.0*10.7	0 P 303	54.11.0125	1 pce	1p	Pin, 1reihig, winkel
0 C 17	59.60.2361	1 pce	330p	CER 50V, 5%, COG, 0805	0 P 304	54.11.0125	1 pce	1p	Pin, 1reihig, winkel
0 C 18	59.68.0033	1 pce	470u	EL 6V, 8.0*10.7	0 P 305	54.11.0125	1 pce	1p	Pin, 1reihig, winkel
0 C 19	59.68.0073	1 pce	220u	EL 16V, 8.0*10.7	0 P 306	54.11.0125	1 pce	1p	Pin, 1reihig, winkel
0 C 20	59.60.2361	1 pce	330p	CER 50V, 5%, COG, 0805	0 P 307	54.11.0125	1 pce	1p	Pin, 1reihig, winkel
0 C 21	59.68.0033	1 pce	470u	EL 6V, 8.0*10.7	0 P 308	54.11.0125	1 pce	1p	Pin, 1reihig, winkel
0 C 22	59.68.0073	1 pce	220u	EL 16V, 8.0*10.7	0 P 309	54.11.0125	1 pce	1p	Pin, 1reihig, winkel
0 C 23	59.60.3337	1 pce	100n	CER 50V, 10%, X7R, 0805	0 P 310	54.11.0125	1 pce	1p	Pin, 1reihig, winkel
0 C 24	59.60.2373	1 pce	1n0	CER 50V, 5%, COG, 0805	0 P 311	54.11.0125	1 pce	1p	Pin, 1reihig, winkel
0 C 25	59.60.2373	1 pce	1n0	CER 50V, 5%, COG, 0805	0 P 312	54.11.0125	1 pce	1p	Pin, 1reihig, winkel
0 C 26	59.60.3337	1 pce	100n	CER 50V, 10%, X7R, 0805	0 P 313	54.11.0125	1 pce	1p	Pin, 1reihig, winkel
0 C 27	59.60.3337	1 pce	100n	CER 50V, 10%, X7R, 0805	0 Q 1	50.60.1002	1 pce	BC860C	PNP 45V 100mA SOT 23
0 C 28	59.60.3337	1 pce	100n	CER 50V, 10%, X7R, 0805	0 Q 2	50.60.1002	1 pce	BC860C	PNP 45V 100mA SOT 23
0 C 29	59.60.2373	1 pce	1n0	CER 50V, 5%, COG, 0805	0 Q 3	50.60.0050	1 pce	BC817-25	NPN 45V 800mA SOT 23
0 C 30	59.60.3337	1 pce	100n	CER 50V, 10%, X7R, 0805	0 Q 4	50.60.1050	1 pce	BC807-25	PNP 45V 800mA SOT 23
0 C 31	59.60.2369	1 pce	680p	CER 50V, 5%, COG, 0805	0 Q 5	50.60.1002	1 pce	BC860C	PNP 45V 100mA SOT 23
0 C 32	59.60.3337	1 pce	100n	CER 50V, 10%, X7R, 0805	0 Q 6	50.60.1002	1 pce	BC860C	PNP 45V 100mA SOT 23
0 C 33	59.60.3337	1 pce	100n	CER 50V, 10%, X7R, 0805	0 R 1	57.60.1222	1 pce	2k2	MF, 1%, 0204, E24
0 C 34	59.68.0073	1 pce	220u	EL 16V, 8.0*10.7	0 R 2	57.60.1223	1 pce	22k	MF, 1%, 0204, E24
0 C 35	59.68.0073	1 pce	220u	EL 16V, 8.0*10.7	0 R 3	57.60.1000	1 pce	0R0	MF, 0204
0 C 36	59.60.2373	1 pce	1n0	CER 50V, 5%, COG, 0805	0 R 4	not used	1 pce	0R0	MF, 0204
0 C 37	59.60.3337	1 pce	100n	CER 50V, 10%, X7R, 0805	0 R 5	57.60.1222	1 pce	2k2	MF, 1%, 0204, E24
0 C 38	59.60.3337	1 pce	100n	CER 50V, 10%, X7R, 0805	0 R 6	57.60.1222	1 pce	2k2	MF, 1%, 0204, E24
0 C 39	59.60.2241	1 pce	47p	CER 50V, 5%, COG, 0603	0 R 7	57.60.1223	1 pce	22k	MF, 1%, 0204, E24
0 C 40	59.60.3333	1 pce	47n	CER 50V, 10%, X7R, 0805	0 R 8	57.60.1000	1 pce	0R0	MF, 0204
0 C 41	59.60.3337	1 pce	100n	CER 50V, 10%, X7R, 0805	0 R 9	not used	1 pce	0R0	MF, 0204
0 D 1	50.60.8001	1 pce	4448	200mA 75V 4ns SOD 80	0 R 10	57.60.1000	1 pce	0R0	MF, 0204
0 D 2	50.60.8001	1 pce	4448	200mA 75V 4ns SOD 80	0 R 11	not used	1 pce	0R0	MF, 0204
0 D 3	50.60.8001	1 pce	4448	200mA 75V 4ns SOD 80	0 R 12	57.60.1682	1 pce	6k8	MF, 1%, 0204, E24
0 D 4	50.60.8001	1 pce	4448	200mA 75V 4ns SOD 80	0 R 13	57.60.1682	1 pce	6k8	MF, 1%, 0204, E24
0 D 5	50.60.8001	1 pce	4448	200mA 75V 4ns SOD 80	0 R 14	not used	1 pce	0R0	MF, 0204
0 D 6	50.60.8001	1 pce	4448	200mA 75V 4ns SOD 80	0 R 15	57.60.1000	1 pce	0R0	MF, 0204
0 D 7	50.60.8001	1 pce	4448	200mA 75V 4ns SOD 80	0 R 16	57.60.1122	1 pce	1k2	MF, 1%, 0204, E24
0 D 8	50.60.8001	1 pce	4448	200mA 75V 4ns SOD 80	0 R 17	57.60.1105	1 pce	1M0	MF, 1%, 0204, E24
0 DL 1	50.04.2150	1 pce	MV57164	10*LED-Bargraf rot diffus	0 R 18	57.60.1392	1 pce	3k9	MF, 1%, 0204, E24
0 DL 2	50.04.2161	1 pce	GRN	DLZ MV 54 164, LTA1000G 10°D GN	0 R 19	57.60.1682	1 pce	6k8	MF, 1%, 0204, E24
0 DL 3	50.04.2161	1 pce	GRN	DLZ MV 54 164, LTA1000G 10°D GN	0 R 20	57.60.1330	1 pce	33R	MF, 1%, 0204, E24
0 DL 4	50.04.2150	1 pce	MV57164	10*LED-Bargraf rot diffus	0 R 21	57.60.1122	1 pce	1k2	MF, 1%, 0204, E24
0 DV 1	50.60.9017	1 pce	10V	5%, 0.2W, SOT 23	0 R 22	57.60.1102	1 pce	1k0	MF, 1%, 0204, E24
0 DV 2	50.60.9017	1 pce	10V	5%, 0.2W, SOT 23	0 R 23	57.60.1512	1 pce	5k1	MF, 1%, 0204, E24
0 DV 3	50.60.9010	1 pce	5V1	5%, 0.2W, SOT 23	0 R 24	57.60.1512	1 pce	5k1	MF, 1%, 0204, E24
4 DV 4	50.04.1112	1 pce	5V1	Zener, 5%, 0.5W, DO-35	2 R 25	not used	1 pce	0R0	MF, 0204
0 IC 1	50.11.0119	1 pce	LM3914	IC LM 3914 N,	0 R 26	57.60.1471	1 pce	470R	MF, 1%, 0204, E24
0 IC 2	50.11.0119	1 pce	LM3914	IC LM 3914 N,	0 R 27	57.99.0252	1 pce	47	MF 10%, +4500ppm
0 IC 3	50.11.0119	1 pce	LM3914	IC LM 3914 N,	0 R 28	57.60.1564	1 pce	560k	MF, 1%, 0204, E24
0 IC 4	50.11.0119	1 pce	LM3914	IC LM 3914 N,	0 R 29	57.60.1512	1 pce	5k1	MF, 1%, 0204, E24
0 IC 5	50.61.0204	1 pce	MC33078	Dual Op-Amp low noise	0 R 30	57.60.1104	1 pce	100k	MF, 1%, 0204, E24
0 IC 6	50.61.0207	1 pce	LF353	Dual Op-Amp JFET SO 8	0 R 31	57.60.1182	1 pce	1k8	MF, 1%, 0204, E24
3 IC 7	50.61.0209	1 pce	LF412	Dual Op-Amp JFET SO 8	0 R 32	57.60.1362	1 pce	3k6	MF, 1%, 0204, E24
0 IC 8	50.61.0207	1 pce	LF353	Dual Op-Amp JFET SO 8	0 R 33	57.60.1362	1 pce	3k6	MF, 1%, 0204, E24
1 IC 9	50.61.0204	1 pce	MC33078	Dual Op-Amp low noise	0 R 34	57.60.1821	1 pce	820R	MF, 1%, 0204, E24
0 J 2	54.01.0021	1 pce	Jumper	0.63*0.63mm, Au	0 R 35	57.60.1512	1 pce	5k1	MF, 1%, 0204, E24
0 J 3	54.01.0021	1 pce	Jumper	0.63*0.63mm, Au	0 R 36	57.60.1000	1 pce	0R0	MF, 0204
0 MP 1	1.913.293.11	1 pce		VU/PPM/GRM METER PCB	0 R 37	57.60.1000	1 pce	0R0	MF, 0204
0 MP 2	1.913.293.10	1 pce		NR-ETIKETTE 5 * 20	0 R 38	57.60.1104	1 pce	100k	MF, 1%, 0204, E24
0 MP 3	43.01.0108	1 pce	Label	ESE-Warnschild	0 R 39	57.60.1104	1 pce	100k	MF, 1%, 0204, E24
0 MP 4	28.99.0119	2 pcs		ROHRNIETE D 2.5*0.15" 9	0 R 40	57.60.1000	1 pce	0R0	MF, 0204
0 MP 5	1.010.057.22	1 pce	M3*7.4	Nietmutter sw 6	0 R 41	57.60.1000	1 pce	0R0	MF, 0204
0 MP 6	1.010.057.22	1 pce	M3*7.4	Nietmutter sw 6	0 R 42	57.60.1335	1 pce	3M3	MF, 1%, 0204, E24
0 MP 7	1.010.057.22	1 pce	M3*7.4	Nietmutter sw 6	0 R 43	57.60.1125	1 pce	1M2	MF, 1%, 0204, E24
0 MP 8	1.010.057.22	1 pce	M3*7.4	Nietmutter sw 6	0 R 44	57.60.1106	1 pce	10M	MF, 1%, 0204, E24
4 MP 9	43.10.0113	1 pce	D	Revisions-Etikette 5mm h/blau	0 R 45	57.60.1000	1 pce	0R0	MF, 0204
0 P 1	54.14.2011	1 pce	10p	Winkelstecker Au	0 R 46	57.60.1000	1 pce	0R0	MF, 0204
0 P 2	54.11.0136	1 pce	2*3p	Pin 0.63*0.63, RM2.54	0 R 47	57.60.1104	1 pce	100k	MF, 1%, 0204, E24
0 P 3	54.11.0136	1 pce	2*3p	Pin 0.63*0.63, RM2.54	0 R 48	57.60.1182	1 pce	1k8	MF, 1%, 0204, E24
0 P 102	54.11.0125	1 pce	1p	Pin, 1reihig, winkel	0 R 49	57.60.1182	1 pce	1k8	MF, 1%, 0204, E24
0 P 103	54.11.0125	1 pce	1p	Pin, 1reihig, winkel	0 R 50	57.92.7012	1 pce	0.3A	PTC 60V
0 P 104	54.11.0125	1 pce	1p	Pin, 1reihig, winkel	0 R 51	57.60.1273	1 pce	27k	MF, 1%, 0204, E24
0 P 105	54.11.0125	1 pce	1p	Pin, 1reihig, winkel	0 R 52	57.60.1153	1 pce	15k	MF, 1%, 0204, E24
0 P 106	54.11.0125	1 pce	1p	Pin, 1reihig, winkel	0 R 53	57.60.1222	1 pce	2k2	MF, 1%, 0204, E24
0 P 107	54.11.0125	1 pce	1p	Pin, 1reihig, winkel	0 R 54	57.60.1272	1 pce	2k7	MF, 1%, 0204, E24
0 P 108	54.11.0125	1 pce	1p	Pin, 1reihig, winkel	0 R 55	57.60.1184	1 pce	180k	MF, 1%, 0204, E24
0 P 109	54.11.0125	1 pce	1p	Pin, 1reihig, winkel	0 R 56	57.60.1106	1 pce	10M	MF, 1%, 0204, E24
0 P 110	54.11.0125	1 pce	1p	Pin, 1reihig, winkel	0 R 57	57.60.1512	1 pce	5k1	MF, 1%, 0204, E24
0 P 111	54.11.0125	1 pce	1p	Pin, 1reihig, winkel	0 R 58	57.60.1512	1 pce	5k1	MF, 1%, 0204, E24
0 P 112	54.11.0125	1 pce	1p	Pin, 1reihig, winkel	0 R 59	57.60.1471	1 pce	470R	MF, 1%, 0204, E24
0 P 113	54.11.0125	1 pce	1p	Pin, 1reihig, winkel	0 R 60	57.60.1562	1 pce	5k6	MF, 1%, 0204, E24
0 P 114	54.11.0125	1 pce	1p	Pin, 1reihig, winkel	0 R 66	57.60.1103	1 pce	10k	MF, 1%, 0204, E24
0 P 115	54.11.0125	1 pce	1p	Pin, 1reihig, winkel	0 RA 1	58.60.0121	1 pce	20k	SMD 20%, 0.25W, Cermet
0 P 116	54.11.0125	1 pce	1p	Pin, 1reihig, winkel	0 RA 2	58.60.0113	1 pce	1k0	SMD 20%, 0.25W, Cermet
0 P 117	54.11.0125	1 pce	1p	Pin, 1reihig, winkel	0 RA 3	58.01.9103	1 pce	10k	Cermet, 10%, 0.5W, vertical
0 P 118	54.11.0125	1 pce	1p	Pin, 1reihig, winkel	0 RA 4	58.01.9503	1 pce	50k	Cermet, 10%, 0.5W, vertical
0 P 119	54.11.0125	1 pce	1p	Pin, 1reihig, winkel	0 T 1	1.022.625.00	1 pce		SCHALTTRAFO 3:1
0 P 120	54.11.0125	1 pce	1p	Pin, 1reihig, winkel	0 T 2	1.022.2			

VU/PPM/GRM Meter 1.913.293.00 (4)

Page: 2 of 2

Idx. Pos.	Part No.	Qty.	Type/Val.	Description
0	TP 5	54.02.0471	1 pce	Stift d 1.5 * 5.5 löf
0	TP 6	not used	1 pce	Stift d 1.5 * 5.5 löf
0	TP 7	not used	1 pce	Stift d 1.5 * 5.5 löf

Idx. Pos.	Part No.	Qty.	Type/Val.	Description
-----------	----------	------	-----------	-------------

End of List

Comments:

- (01) Offset-voltage of IC 9 LF 353 too large
->replaced by MC
- (02) R25 not used
- (03) IC7 LF353 replaced by LF412
- (04) DV4 added

VU/PPM Meter mod. 1.913.294.00 (3)

Idx. Pos.	Part No.	Qty.	Type/Val.	Description
0 C 1	59.60.3337	1 pce	100n	CER 50V, 10%, X7R, 0805
0 C 2	59.60.3337	1 pce	100n	CER 50V, 10%, X7R, 0805
0 C 6	59.60.3337	1 pce	100n	CER 50V, 10%, X7R, 0805
0 C 7	59.60.3337	1 pce	100n	CER 50V, 10%, X7R, 0805
0 C 8	59.60.3337	1 pce	100n	CER 50V, 10%, X7R, 0805
0 C 9	59.60.3337	1 pce	100n	CER 50V, 10%, X7R, 0805
0 C 10	59.60.3337	1 pce	100n	CER 50V, 10%, X7R, 0805
0 C 11	59.60.3337	1 pce	100n	CER 50V, 10%, X7R, 0805
0 C 12	59.60.2373	1 pce	1n0	CER 50V, 5%, COG, 0805
0 C 13	59.60.2241	1 pce	47p	CER 50V, 5%, COG, 0603
0 C 14	59.60.3337	1 pce	100n	CER 50V, 10%, X7R, 0805
0 C 15	59.60.3337	1 pce	100n	CER 50V, 10%, X7R, 0805
0 C 16	59.68.0033	1 pce	470u	EL 6V, 8.0*10.7
0 C 17	59.60.2361	1 pce	330p	CER 50V, 5%, COG, 0805
0 C 18	59.68.0033	1 pce	470u	EL 6V, 8.0*10.7
0 C 19	59.68.0073	1 pce	220u	EL 16V, 8.0*10.7
0 C 20	59.60.2361	1 pce	330p	CER 50V, 5%, COG, 0805
0 C 21	59.68.0033	1 pce	470u	EL 6V, 8.0*10.7
0 C 22	59.68.0073	1 pce	220u	EL 16V, 8.0*10.7
0 C 25	59.60.2373	1 pce	1n0	CER 50V, 5%, COG, 0805
0 C 26	59.60.3337	1 pce	100n	CER 50V, 10%, X7R, 0805
0 C 27	59.60.3337	1 pce	100n	CER 50V, 10%, X7R, 0805
0 C 30	59.60.3337	1 pce	100n	CER 50V, 10%, X7R, 0805
0 C 31	59.60.2369	1 pce	680p	CER 50V, 5%, COG, 0805
0 C 32	59.60.3337	1 pce	100n	CER 50V, 10%, X7R, 0805
0 C 33	59.60.3337	1 pce	100n	CER 50V, 10%, X7R, 0805
0 C 34	59.68.0073	1 pce	220u	EL 16V, 8.0*10.7
0 C 35	59.68.0073	1 pce	220u	EL 16V, 8.0*10.7
0 C 37	59.60.3337	1 pce	100n	CER 50V, 10%, X7R, 0805
0 C 38	59.60.3337	1 pce	100n	CER 50V, 10%, X7R, 0805
0 C 39	59.60.2241	1 pce	47p	CER 50V, 5%, COG, 0603
0 C 40	59.60.3333	1 pce	47n	CER 50V, 10%, X7R, 0805
0 C 41	59.60.3337	1 pce	100n	CER 50V, 10%, X7R, 0805
0 D 1	50.60.8001	1 pce	4448	200mA 75V 4ns SOD 80
0 D 2	50.60.8001	1 pce	4448	200mA 75V 4ns SOD 80
0 D 3	50.60.8001	1 pce	4448	200mA 75V 4ns SOD 80
0 D 4	50.60.8001	1 pce	4448	200mA 75V 4ns SOD 80
0 D 5	50.60.8001	1 pce	4448	200mA 75V 4ns SOD 80
0 D 6	50.60.8001	1 pce	4448	200mA 75V 4ns SOD 80
0 D 7	50.60.8001	1 pce	4448	200mA 75V 4ns SOD 80
0 D 8	50.60.8001	1 pce	4448	200mA 75V 4ns SOD 80
0 DL 1	50.04.2150	1 pce		10*LED-Bargraf rot diffus
0 DL 2	50.04.2161	1 pce		DLZ MV 54 164,LTA1000G 10*D GN
0 DL 3	50.04.2161	1 pce		DLZ MV 54 164,LTA1000G 10*D GN
0 DV 1	50.60.9017	1 pce	10V	5%, 0.2W, SOT 23
0 DV 2	50.60.9017	1 pce	10V	5%, 0.2W, SOT 23
3 DV 4	50.04.1112	1 pce	5V1	Zener, 5%, 0.5W, DO-35
0 IC 1	50.11.0119	1 pce		IC LM 3914 N,
0 IC 2	50.11.0119	1 pce		IC LM 3914 N,
0 IC 3	50.11.0119	1 pce		IC LM 3914 N,
0 IC 5	50.61.0204	1 pce		Dual Op-Amp low noise
0 IC 6	50.61.0207	1 pce		Dual Op-Amp JFET SO 8
0 IC 7	50.61.0207	1 pce		Dual Op-Amp JFET SO 8
1 IC 9	50.61.0204	1 pce		Dual Op-Amp low noise
0 J 2	54.01.0021	1 pce		Jumper
0 J 3	54.01.0021	1 pce		Jumper
0 MP 1	1.913.293.11	1 pce		VU/PPM/GRM METER PCB
0 MP 2	1.913.294.10	1 pce		NR-ETIKETTE 5 * 20
0 MP 3	43.01.0108	1 pce		ESE-Warnschild
0 MP 4	28.99.0119	2 pcs		ROHRNIETE D 2.5*0.15* 9
0 MP 5	1.010.057.22	1 pce		M3*7.4
0 MP 6	1.010.057.22	1 pce		M3*7.4
3 MP 7	43.10.0112	1 pce		C
0 P 1	54.14.2011	1 pce		10p
0 P 2	54.11.0136	1 pce		2*3p
0 P 3	54.11.0136	1 pce		2*3p
0 P 101	54.11.0125	1 pce		Pin, 1reihiig, winkel
0 P 102	54.11.0125	1 pce		Pin, 1reihiig, winkel
0 P 103	54.11.0125	1 pce		Pin, 1reihiig, winkel
0 P 104	54.11.0125	1 pce		Pin, 1reihiig, winkel
0 P 105	54.11.0125	1 pce		Pin, 1reihiig, winkel
0 P 106	54.11.0125	1 pce		Pin, 1reihiig, winkel
0 P 107	54.11.0125	1 pce		Pin, 1reihiig, winkel
0 P 108	54.11.0125	1 pce		Pin, 1reihiig, winkel
0 P 109	54.11.0125	1 pce		Pin, 1reihiig, winkel
0 P 110	54.11.0125	1 pce		Pin, 1reihiig, winkel
0 P 111	54.11.0125	1 pce		Pin, 1reihiig, winkel
0 P 112	54.11.0125	1 pce		Pin, 1reihiig, winkel
0 P 113	54.11.0125	1 pce		Pin, 1reihiig, winkel
0 P 114	54.11.0125	1 pce		Pin, 1reihiig, winkel
0 P 115	54.11.0125	1 pce		Pin, 1reihiig, winkel
0 P 116	54.11.0125	1 pce		Pin, 1reihiig, winkel
0 P 117	54.11.0125	1 pce		Pin, 1reihiig, winkel
0 P 118	54.11.0125	1 pce		Pin, 1reihiig, winkel
0 P 119	54.11.0125	1 pce		Pin, 1reihiig, winkel
0 P 120	54.11.0125	1 pce		Pin, 1reihiig, winkel
0 P 121	54.11.0125	1 pce		Pin, 1reihiig, winkel
0 P 122	54.11.0125	1 pce		Pin, 1reihiig, winkel
0 P 123	54.11.0125	1 pce		Pin, 1reihiig, winkel
0 P 124	54.11.0125	1 pce		Pin, 1reihiig, winkel
0 P 125	54.11.0125	1 pce		Pin, 1reihiig, winkel
0 P 126	54.11.0125	1 pce		Pin, 1reihiig, winkel
0 P 127	54.11.0125	1 pce		Pin, 1reihiig, winkel
0 P 128	54.11.0125	1 pce		Pin, 1reihiig, winkel
0 P 129	54.11.0125	1 pce		Pin, 1reihiig, winkel
0 P 130	54.11.0125	1 pce		Pin, 1reihiig, winkel
0 P 131	54.11.0125	1 pce		Pin, 1reihiig, winkel
0 P 132	54.11.0125	1 pce		Pin, 1reihiig, winkel
0 P 133	54.11.0125	1 pce		Pin, 1reihiig, winkel
0 P 134	54.11.0125	1 pce		Pin, 1reihiig, winkel
0 P 135	54.11.0125	1 pce		Pin, 1reihiig, winkel
0 P 136	54.11.0125	1 pce		Pin, 1reihiig, winkel

Idx. Pos.	Part No.	Qty.	Type/Val.	Description
0 Q 1	50.60.1002	1 pce	BC860C	PNP 45V 100mA SOT 23
0 Q 2	50.60.1002	1 pce	BC860C	PNP 45V 100mA SOT 23
0 Q 3	50.60.0050	1 pce	BC817-25	NPN 45V 800mA SOT 23
0 Q 4	50.60.1050	1 pce	BC807-25	PNP 45V 800mA SOT 23
0 Q 5	50.60.1002	1 pce	BC860C	PNP 45V 100mA SOT 23
0 Q 6	50.60.1002	1 pce	BC860C	PNP 45V 100mA SOT 23
0 R 1	57.60.1222	1 pce	2k2	MF, 1%, 0204, E24
0 R 2	57.60.1223	1 pce	22k	MF, 1%, 0204, E24
0 R 3	57.60.1000	1 pce	0R0	MF, 0204
0 R 4		1 pce	not used	MF, 0204
0 R 5	57.60.1222	1 pce	2k2	MF, 1%, 0204, E24
0 R 6	57.60.1222	1 pce	2k2	MF, 1%, 0204, E24
0 R 7	57.60.1223	1 pce	22k	MF, 1%, 0204, E24
0 R 8	57.60.1000	1 pce	0R0	MF, 0204
0 R 9		1 pce	not used	MF, 0204
0 R 10	57.60.1000	1 pce	0R0	MF, 0204
0 R 11		1 pce	not used	MF, 0204
0 R 16	57.60.1122	1 pce	1k2	MF, 1%, 0204, E24
0 R 17	57.60.1105	1 pce	1M0	MF, 1%, 0204, E24
0 R 18	57.60.1392	1 pce	3k9	MF, 1%, 0204, E24
0 R 19	57.60.1682	1 pce	6k8	MF, 1%, 0204, E24
0 R 20	57.60.1330	1 pce	33R	MF, 1%, 0204, E24
0 R 21	57.60.1122	1 pce	1k2	MF, 1%, 0204, E24
0 R 22	57.60.1102	1 pce	1k0	MF, 1%, 0204, E24
0 R 23	57.60.1512	1 pce	5k1	MF, 1%, 0204, E24
0 R 24	57.60.1512	1 pce	5k1	MF, 1%, 0204, E24
2 R 25		1 pce	not used	MF, 0204
0 R 26	57.60.1471	1 pce	470R	MF, 1%, 0204, E24
0 R 27	57.99.0252	1 pce	47	MF 10%, +4500ppm
0 R 28	57.60.1564	1 pce	560k	MF, 1%, 0204, E24
0 R 29	57.60.1512	1 pce	5k1	MF, 1%, 0204, E24
0 R 31	57.60.1182	1 pce	1k8	MF, 1%, 0204, E24
0 R 32	57.60.1362	1 pce	3k6	MF, 1%, 0204, E24
0 R 33	57.60.1362	1 pce	3k6	MF, 1%, 0204, E24
0 R 34	57.60.1821	1 pce	820R	MF, 1%, 0204, E24
0 R 35	57.60.1512	1 pce	5k1	MF, 1%, 0204, E24
0 R 42	57.60.1335	1 pce	3M3	MF, 1%, 0204, E24
0 R 43	57.60.1125	1 pce	1M2	MF, 1%, 0204, E24
0 R 44	57.60.1106	1 pce	10M	MF, 1%, 0204, E24
0 R 48	57.60.1182	1 pce	1k8	MF, 1%, 0204, E24
0 R 49	57.60.1182	1 pce	1k8	MF, 1%, 0204, E24
0 R 50	57.92.7012	1 pce	0.3A	PTC 60V
0 R 52	57.60.1153	1 pce	15k	MF, 1%, 0204, E24
0 R 53	57.60.1222	1 pce	2k2	MF, 1%, 0204, E24
0 R 54	57.60.1272	1 pce	2k7	MF, 1%, 0204, E24
0 R 55	57.60.1184	1 pce	180k	MF, 1%, 0204, E24
0 R 56	57.60.1106	1 pce	10M	MF, 1%, 0204, E24
0 R 57	57.60.1512	1 pce	5k1	MF, 1%, 0204, E24
0 R 58	57.60.1512	1 pce	5k1	MF, 1%, 0204, E24
0 R 59	57.60.1471	1 pce	470R	MF, 1%, 0204, E24
0 R 66	57.60.1103	1 pce	10k	MF, 1%, 0204, E24
0 RA 1	58.60.0121	1 pce	20k	SMD 20%, 0.25W, Cermet
0 RA 2	58.60.0113	1 pce	1k0	SMD 20%, 0.25W, Cermet
0 RA 3	58.01.9103	1 pce	10k	Cermet, 10%, 0.5W, vertical
0 T 1	1.022.625.00	1 pce		SCHALTTRAFO 3:1
0 T 2	1.022.218.00	1 pce	1 : 1	EINGANGSTRAFO 1 : 1
0 TP 1	54.02.0471	1 pce		Stift d 1.5 * 5.5 lötl
0 TP 2	54.02.0471	1 pce		Stift d 1.5 * 5.5 lötl
0 TP 3	54.02.0471	1 pce		Stift d 1.5 * 5.5 lötl
0 TP 4	54.02.0471	1 pce		Stift d 1.5 * 5.5 lötl
0 TP 5	54.02.0471	1 pce		Stift d 1.5 * 5.5 lötl

End of List

Comments:

- (01) Offset-voltage of IC 9 LF 353 too large
->replaced by MC 33078
- (02) R25 not used
- (03) DV4 added

LED PPM Meter (10 LED) 1.913.291.00

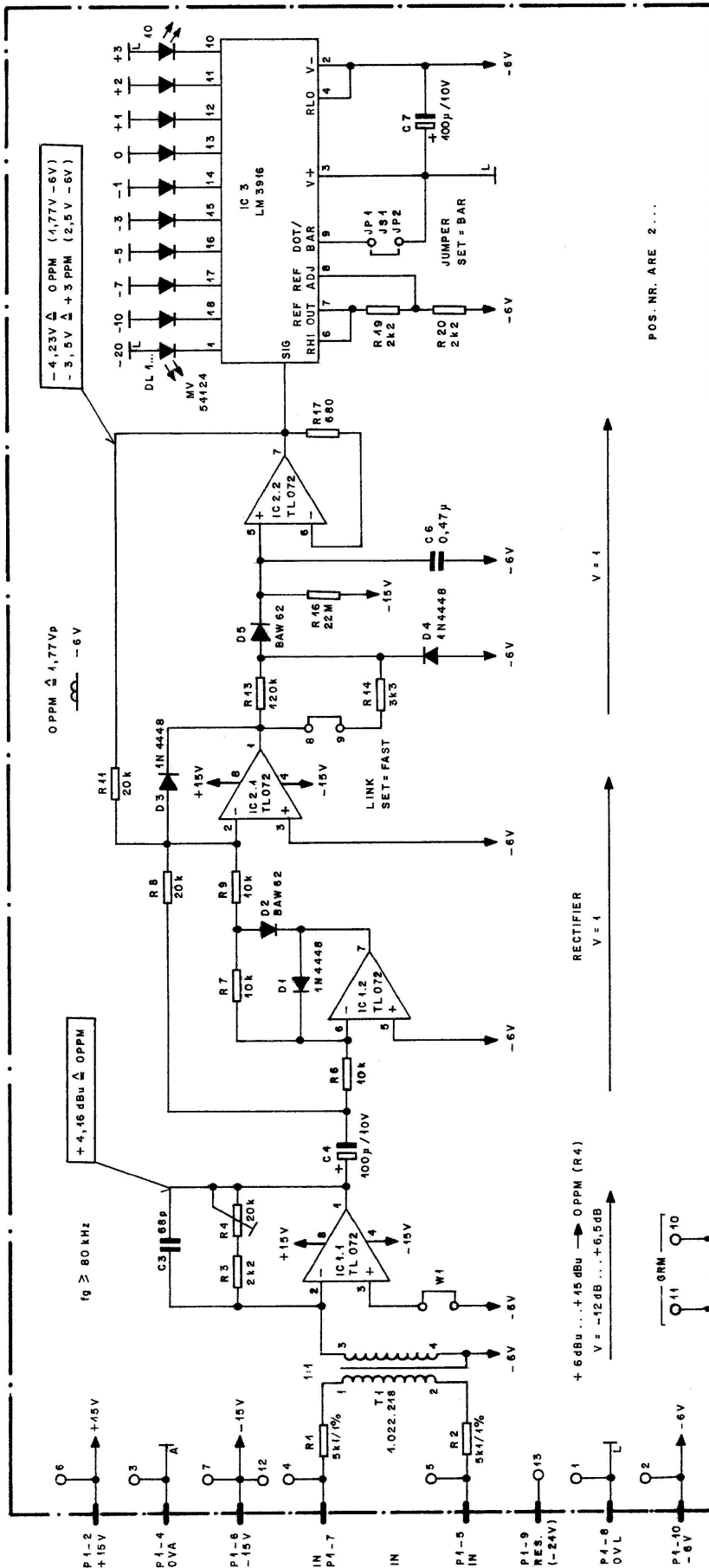

POS. NR. ARE 2...

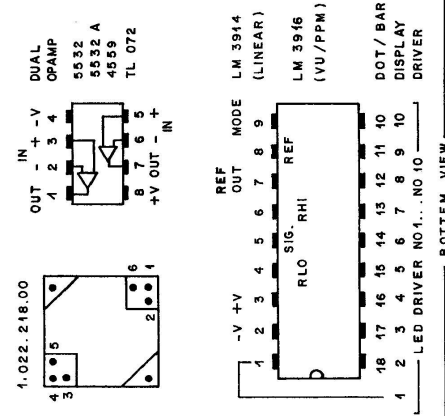

P	NO NAME	REMARK (PCB CONNECTOR)
P..1	1 GRM	INPUT GRM
P..1	2 +10V	+ SUPPLY
P..1	3 GRM	INPUT GRM
P..1	4 OV-A	GROUND AUDIO
P..1	5 IN	INPUT AUDIO
P..1	6 -45V	- SUPPLY
P..1	7 IN	INPUT AUDIO
P..1	8 OV-L	GROUND SIGN. (LOGIC)
P..1	9 RES.	RESERVE (-24V)
P..1	10 -6V	- SUPPLY

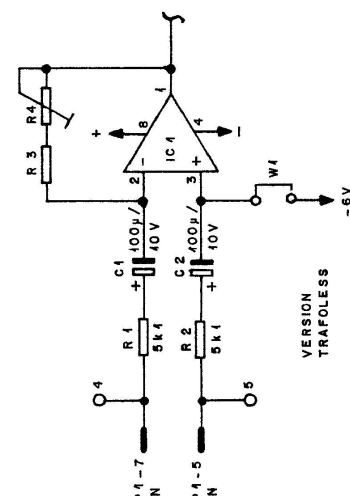

LED PPM Meter (10 LED) 1.913.291.00

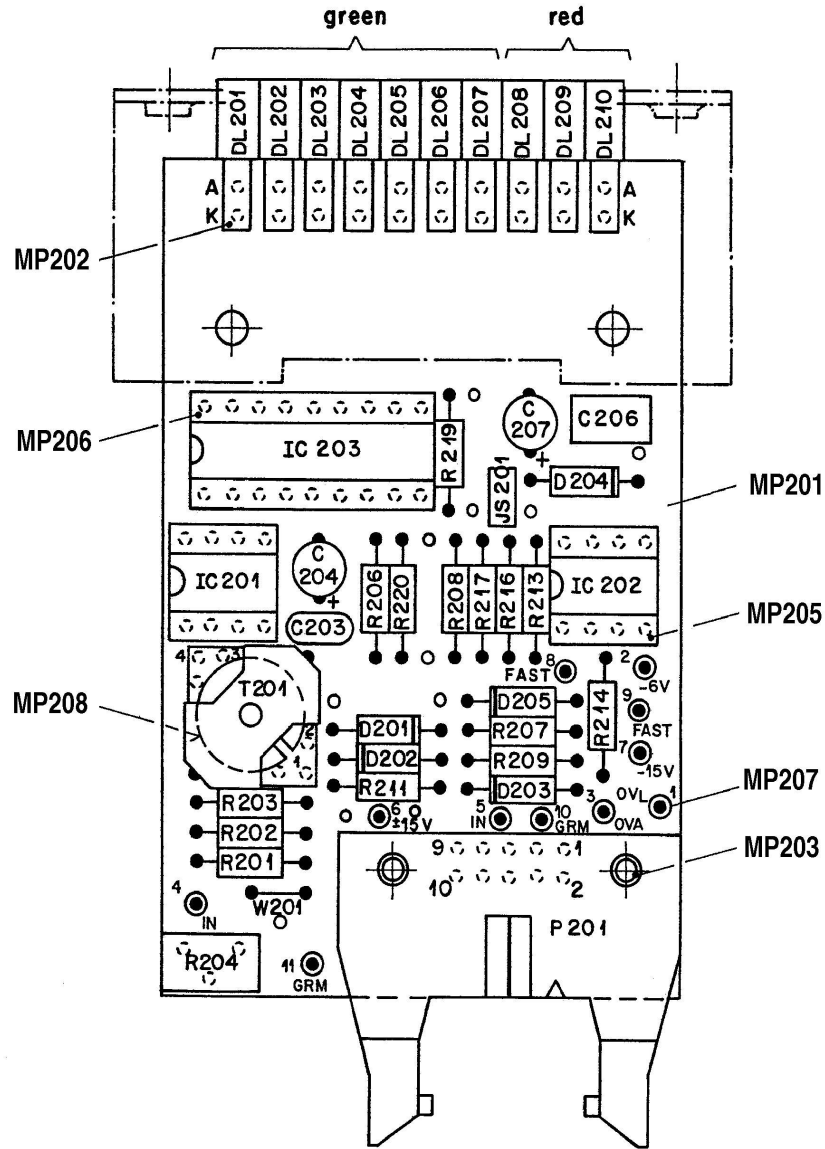

Werkstoff	Norm-Nr.:	Güte:		Änderung					③	
	DIN-Bez.:	Beh.:								②
	Abmessung:									①
Zugehörige Unterlagen:		Freimasstoleranz:	Maßstab:	Ausgabe	22.10.87	A.Ho	Zi	Ja	④	
PL		±		Datum	Gez.	Gepr.	Ges.	Index		
Ersatz für:		Ersetzt durch:		Kopie für:						
STUDER REGENSDORF ZÜRICH		Benennung: LED PPM METER ESE				Nummer: 1.913.291-00				

LED PPM Meter (10 LED) 1.913.291.00 (1)

Idx. Pos.	Part No.	Qty.	Type/Val.	Description	Idx. Pos.	Part No.	Qty.	Type/Val.	Description
0	C 201		not used	not used					
0	C 202		not used	not used					
0	C 203	59.34.2680	68p	CER 63V, 5%, N150					
0	C 204	59.22.3101	100u	EL 10V 20% RM5					
0	C 205		not used	not used					
0	C 206	59.06.5474	470n	PETP, 63V, 5%, RM5					
0	C 207	59.22.3101	100u	EL 10V 20% RM5					
0	D 201	50.04.0125	1N4448	75V, 150mA, 4ns, DO-35					
0	D 202	50.04.0132	BAW62	D BAW 62					
1	D 203	50.04.0125	1N4448	75V, 150mA, 4ns, DO-35					
1	D 204	50.04.0125	1N4448	75V, 150mA, 4ns, DO-35					
0	D 205	50.04.0132	BAW62	D BAW 62					
0	D 206		not used	not used					
0	DL 201	50.04.2146	MV54124A	LED green					
0	DL 202	50.04.2146	MV54124A	LED green					
0	DL 203	50.04.2146	MV54124A	LED green					
0	DL 204	50.04.2146	MV54124A	LED green					
0	DL 205	50.04.2146	MV54124A	LED green					
0	DL 206	50.04.2146	MV54124A	LED green					
0	DL 207	50.04.2146	MV54124A	LED green					
0	DL 208	50.04.2119	MV57124A	LED red					
0	DL 209	50.04.2119	MV57124A	LED red					
0	DL 210	50.04.2119	MV57124A	LED red					
0	IC 201	50.09.0101	TL072	Dual op-amp biFET					
0	IC 202	50.09.0101	TL072	Dual op-amp biFET					
0	IC 203	50.11.0144	LM3916	LED Bar/Dot driver					
0	JP 201	54.01.0020	1p	Pin, 1reihig, gerade					
0	JP 202	54.01.0020	1p	Pin, 1reihig, gerade					
0	JS 201	54.01.0021	Jumper	0.63*0.63mm, Au					
0	MP 201	1.913.290.11	1 pce	LED METER PCB					
0	MP 202	1.010.012.50	10 pcs	LED-spacer universal					
0	MP 203	28.99.0119	2 pcs	ROHRNIETE D 2.5*0.15* 9					
0	MP 204		not used	not used					
0	MP 205	53.03.0166	2 pcs	8p DIL-socket 0.3"					
0	MP 206	53.03.0175	1 pce	18p DIL 0.3", lötl, gerade					
0	MP 207	54.02.0471	11 pcs	Stift d 1.5 * 5.5 lötl					
0	MP 208	1.010.004.61	1 pce	RM5 Isolierscheibe d=10					
0	P 201	54.14.2011	10p	Winkelstecker Au					
0	R 201	57.11.3512	5k1	MF, 1%, 0207					
0	R 202	57.11.3512	5k1	MF, 1%, 0207					
0	R 203	57.11.4222	2k2	MF, 2%, 0207					
0	R 204	58.01.9203	20k	Cermet, 10%, 0.5W, vertical					
0	R 205		not used	not used					
			<i>replaced by W 201</i>						
0	R 206	57.11.4103	10k	MF, 2%, 0207					
0	R 207	57.11.4103	10k	MF, 2%, 0207					
0	R 208	57.11.3203	20k	MF, 1%, 0207					
0	R 209	57.11.4103	10k	MF, 2%, 0207					
0	R 210		not used	not used					
0	R 211	57.11.3203	20k	MF, 1%, 0207					
0	R 212		not used	not used					
			<i>replaced by D 203</i>						
0	R 213	57.11.4823	82k	MF, 2%, 0207					
0	R 214	57.11.4332	3k3	MF, 2%, 0207					
0	R 215		not used	not used					
			<i>replaced by D 205</i>						
0	R 216	57.11.6226	22M	MF, 10%, 0207					
0	R 217	57.11.4681	680R	MF, 2%, 0207					
0	R 218		not used	not used					
0	R 219	57.11.4222	2k2	MF, 2%, 0207					
0	R 220	57.11.4222	2k2	MF, 2%, 0207					
0	R 221		not used	not used					
0	T 201	1.022.218.00	1 : 1	EINGANGSTRAFO 1 : 1					
0	W 201	1.010.321.64	RM5.0	U shaped wire 0.6mm					

End of List

Comments:

(01) D203, D204 changed

Bargraph Display

Contents

page

1. Technical Description	1
2. Technical Data	4
3. Alignments and Settings.....	6
3.1 Adjustments	6
3.2 Connections.....	7
3.3 Function Settings.....	9
4. Block Diagram.....	10
5. Schematics.....	11

REFERENCE

This manual refers to the following units:

Dual Bar Graph PPM	1.913.111
Dual Bar Graph VU	1.913.112
8 Channel Bar Graph PPM	1.913.411
8 Channel Bar Graph VU	1.913.412

1. Technical Description

The output meter, whatever it may be called, is one of the most important tools in audio engineering. Wherever audio signals are being processed, it is an essential, because the output level is an important criterion. On the one hand, maximum output level is needed for achieving the best signal-to-noise ratio, on the other hand the reference level should not be exceeded, particularly in digital recordings, otherwise distortion will increase dramatically.

Two types of output meters with different dynamic characteristics have proven themselves useful in recording studios:

Volume Unit Meter (VU)

The most frequently used instrument for measuring audio frequency signal levels is the VU-meter. In the ANSI standard (American National Standards Institute, Inc.), the mechanical and electrical behavior of the VU-meter was already defined in 1954. The rule is that the indication shall be 99% of the ultimate value (0 VU) when a signal of 0.3 s (300 ms) duration is applied. The overshooting of the indication shall be between 1...1.5%. The rise and decay time are identical in the VU-meter.

In the conventional version a VU-meter consists of a suitable moving coil instrument and a full-wave rectifier connected to the input.

Peak Program Meter (PPM)

The PPM is a more recent instrument. Its behavior is defined in the applicable DIN or IEC standards. The principal difference to the VU-meter is in the integration time: the PPM is a quasi peak value instrument with a long release time. A peak value will be indicated even for very short peaks in a music program.

If a sine wave voltage is applied for 10 ms that yields a level of 0dB, the indication should be -1dB. A release time of 1.7 s is desired for levels down to -20dB (IEC).

Instrument Types

An advanced alternative to electromechanical analog displays are the gas discharge bargraph displays. Neon gas that is induced to glow between two glass plates emits visible light. The plasma display has some decisive advantages over all the other displays. For example: large reading angle and high contrast combined with low power consumption and long life. Its disadvantages are: high anode voltage (250 V), high price, and sophisticated electronic circuitry. Despite these drawbacks this excellent type of display has become the de-facto standard in professional studio applications.

Implementation of the Studer Bargraph Output Meters

The design specifications for a precision metering instrument that would not be too costly but still have a modular design resulted in the following arrangement; two individual circuit boards, one for the two-channel signal processing paths and one for the digital section with the switching power supply. In this way it became feasible to achieve a modular design: four signal modules for eight channels but only one digital module.

BARGRAPH

The operating principle of the individual elements that make up the bargraph display is depicted in the following picture:

Plasma Tube

After the 250 VDC supply voltage has been applied, a continuous glow discharge is triggered between the pre-ionization anode and cathode. Since the area around the pre-ionization segment is not physically isolated from the neighboring segments, the charge carriers diffuse into the area of the reset cathode. When the latter is energized first, a glow discharge occurs also here. The same effect causes the first segment to light up (ignite), if the reset cathode is switched off while cathode 1 is switched on. Although each 5th segment is electrically interconnected, only the lowest one glows because sufficient charge carriers are located in its vicinity.

The cathodes 1-2-3-4-5 / 1-2-3-4...etc. are now controlled in this order. The glow discharge migrates segment by segment to the last segment. A new cycle is then initiated by means of the reset segment.

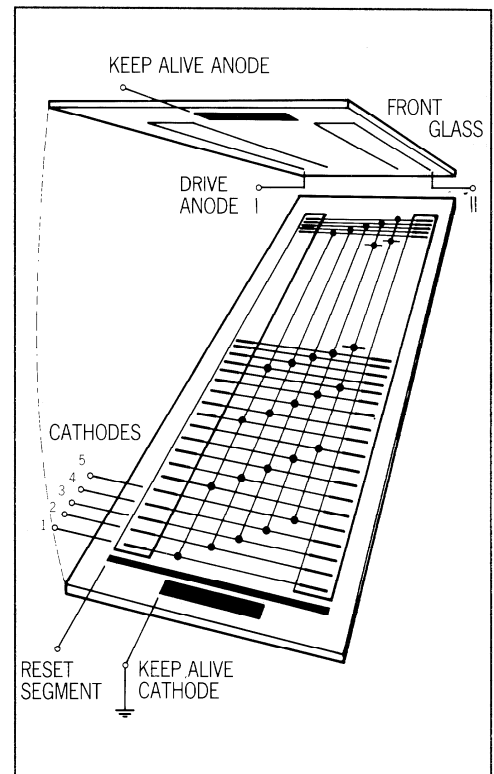

Plasma tube

The length of the bargraph is controlled by the power-on duration of the corresponding anode while the cathodes are controlled cyclically in the dark segment. This design requires only 8 connections or driver stages (2 anodes, 1 reset cathode and 5 write cathodes) for controlling the 2 x 200 segments. In order to create a flicker-free bargraph the refresh rate must be at least 70 Hz. Unnoticeable to the viewer is, however, that only one segment glows at any one moment!

Analog Electronics

The audio section is shown in the block diagram (see p.12). The isolated AF signal is taken to the level stage; the large working range permits the connection of almost any level. For very small levels a +20 dB amplifier is provided. The low-pass filter of the 3rd order attenuates frequencies of over 20 kHz. This circuit is followed by a sophisticated rectifier stage that compensates very carefully with respect to the offset voltages.

For the VU representation, the rectified signal is fed to a filter that duplicates the characteristic of mechanical moving coil instruments. For the PPM representation, the peak value of the rectified signal is formed.

Digital Electronics

The digital section performs various functions. Not only does it process the signals for the plasma tube, it also is responsible for generating the ramp. A totally new approach has been selected for the ramp generation. Normally the audio signal is converted to logarithmic characteristic in an amplifier in order to achieve dB representation. The resulting signal is subsequently compared with a time-linear ramp. However, the same can be accomplished by comparing the linear AF signal with an exponential ramp, without the typical problems of a logarithmic circuit (temperature dependence, offset). In addition, more instruments can be controlled by means of a ramp (in the digital section); no logarithmic circuits are required.

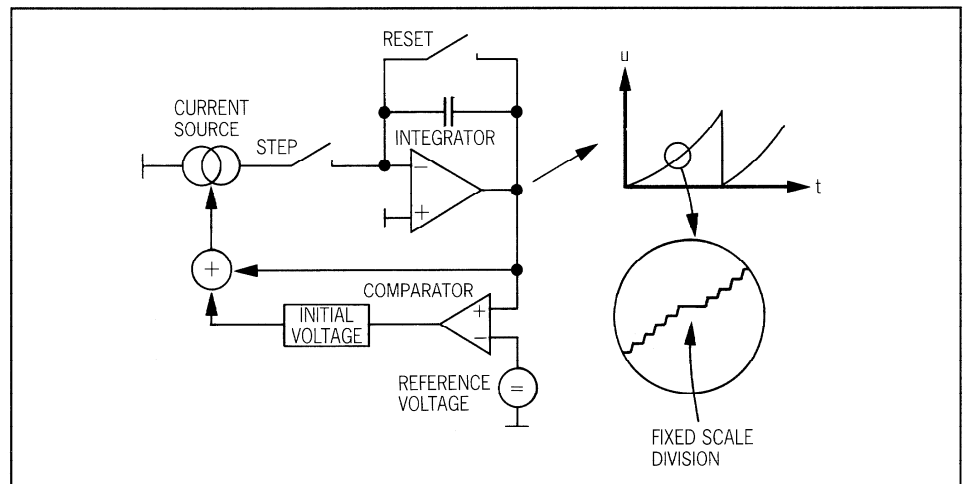

Ramp generator

While a capacitor is charged with a constant current, the terminal voltage rises linearly. If this source is equipped with a positive feedback that converts the continually rising voltage to a continually increasing current, we obtain an exponentially progressing terminal voltage.

If the capacitor is discharged after a while, the initial voltage for starting the cycle is missing. A control circuit is available that prepares the initial voltage in such a way that a reference value is achieved after a certain time.

For inserting fixed scale divisions, the capacitor charging is interrupted during three cycle units. As a result the corresponding segment glows three times longer and consequently appears to be brighter.

By disconnecting the above mentioned positive feedback, the linear ramp is again obtained for representing VU values or representable DC values.

The ramp oscillator also supplies the input signal for a binary counter that increments until reset. The outputs of the counter are address lines for an EPROM which generates the 5-phase signal and a reset signal for creating the fixed scale divisions as well as a reset signal for the counter. With the two remaining address lines it is possible to insert different scale divisions.

Future Application

The new bargraph instrument also features a LED column for indicating limiter or compressor gain reduction signals. With the externally controllable selection of VU or PPM characteristic it is also possible to display DC voltages on linear or logarithmic scale. The built-in switching power supply supports a large range of DC supply voltages.

For PCM recordings a faster response time ($t = 0.1 \text{ ms}$) may be selected by a switch.

BARGRAPH

2. Technical Data

PEAK PROGRAM METER SPECIFICATION

Reference Indication	0 dB = 0 dBu + 15 dBu
Indicating Range	+ 5 dB - 40 dB
Error	± 0.2 dB (± 2 segments) within + 5 dB and - 40 dB
Frequency Response	± 0.5 dB between 31.5 Hz and 16 kHz at 0° C 50° C
Dynamic Response	according to IEC publication 268-10 1974:

SINGLE BURST	FREQUENCY	DEFLECTION VALUE	SLOW TOLERANCE	DEFLECTION FAST
10 ms	3 kHz	- 1 dB	± 0.5 dB	-0,3 dB
5 ms	3 kHz	- 2 dB	± 1 dB	-0,6 dB
3 ms	3 kHz	- 4 dB	± 1 dB	-0,8 dB
0.4 ms	10 kHz	- 15 dB	± 3 dB	-1,0 dB

Overswing	none
Return Time	0 dB - 20 dB: 1.7 ± 0.3 seconds

VU-METER SPECIFICATION

Reference Indication	0 VU = - 4 dBu + 11 dBu
Indicating Range	+ 3 VU - 20 VU, voltage linear
Frequency Response	+ 1.0/- 0.0 dB at 0 VU and 31.5 Hz; Temperature range 0° C 50° C
Response Time	207 ms (± 30 ms) to - 1 VU of reference indication
Overswing	1 ... 1.5 %
Return Time	207 ms (± 30 ms).

DC METER SPECIFICATION**Display Range**

INDICATION	NORMAL			REVERSE
	TOP END	0 V	0 V	- 1 V
BOTTOM	+ 10 V	+ 6 V	+ 6 V	- 10 V

There is mutual influence between the alignment of 'Top End' and 'Bottom' indication. The values in the row 'Normal' are ment to be examples for possible settings.

GENERAL SPECIFICATIONS

Input Impedance	> 10 kOhm
Source Impedance	< 1 kOhm
Reversibility Error	< 0.5 dB
Temperature Range	error \pm 0.5 dB in the range - 10° C ... + 60° C (reference: 1 kHz at 25° C)
Supply Voltage	24 V ... 34 V (or \pm 15 V)
Power Consumption	dual unit: 3.5 W typ., 5.0 W max. 8 channels: 9.5 W typ., 14.5 W max.
Mechanical Dimensions	dual unit: 40 mm(W) x 170 mm(H) x 130 mm(D) 8 channel unit: 160 mm(W) x 170 mm(H) x 130 mm(D)
Weight	dual unit: 640 g 8 channel unit: 1600 g

GR METER SPECIFICATION

Input Range	\pm 2 V ... \pm 5 V for + 20 dB indication
--------------------	--

BARGRAPH

3. Alignments and Settings

Note: The Analog Print 1.913.117 contains two channels, so each adjustment pot exists twice. All adjustments have to be performed on all channels.

The Digital Print 1.913.118 exists only once per unit, be it a two or eight channel device.

3.1 Adjustments

Level Setting

For adaptation to different line levels only the following adjustment is necessary:

- Feed reference level 1 kHz (e.g. +6 dBu)
- adjust 0 dB indication on bargraph with R 5 (R 105) Potentiometer is marked **AUDIO GAIN**

Complete Adjustment

In case of part exchange a full adjustment procedure may be necessary. In this case proceed in the following steps:

AC Input: Set unit to "PPM", "+20 dB off", and "Not fast" (see below)

- Disconnect input, terminate input with 200 Ohm
- adjust minimal level (0 ± 1 mV) at pin 7 of IC 6 (internal potentiometer)
- Feed reference level 1 kHz (e.g. +6 dBu)
- adjust 0 dB indication on bargraph with R 5 (R 105). Potentiometer is marked **AUDIO GAIN**
- Feed 20 dB below reference level 1 kHz (e.g. -14 dBu)
- adjust -20 dB indication with R 64 (potentiometer on digital print; do not readjust after the first channel has been properly adjusted)
- Feed 30 dB below reference level 1 kHz (e.g. -24 dBu)
- adjust -30 dB indication with R 30 (R 130). Potentiometer is marked **AUDIO OFFSET**
- Repeat all steps until all indications are correct.

DC Input: Set unit to "DC" and adjust the wanted input phase configuration (see below).

- Feed maximum DC voltage.
- Adjust maximum indication with R 55 (R 155). Potentiometer is marked **DC GAIN**
- Feed minimum DC voltage
- Adjust minimum indication with R 63 (R 163). Potentiometer is marked **DC REF**
- Repeat all steps until all indications are correct.

- GRM Input:**
- Feed level 1 kHz required for a indication of +20 dB on the gain reduction meter.
 - Adjust indication with R 60 (R 160). Potentiometer is marked **GRM**

3.2 Connections

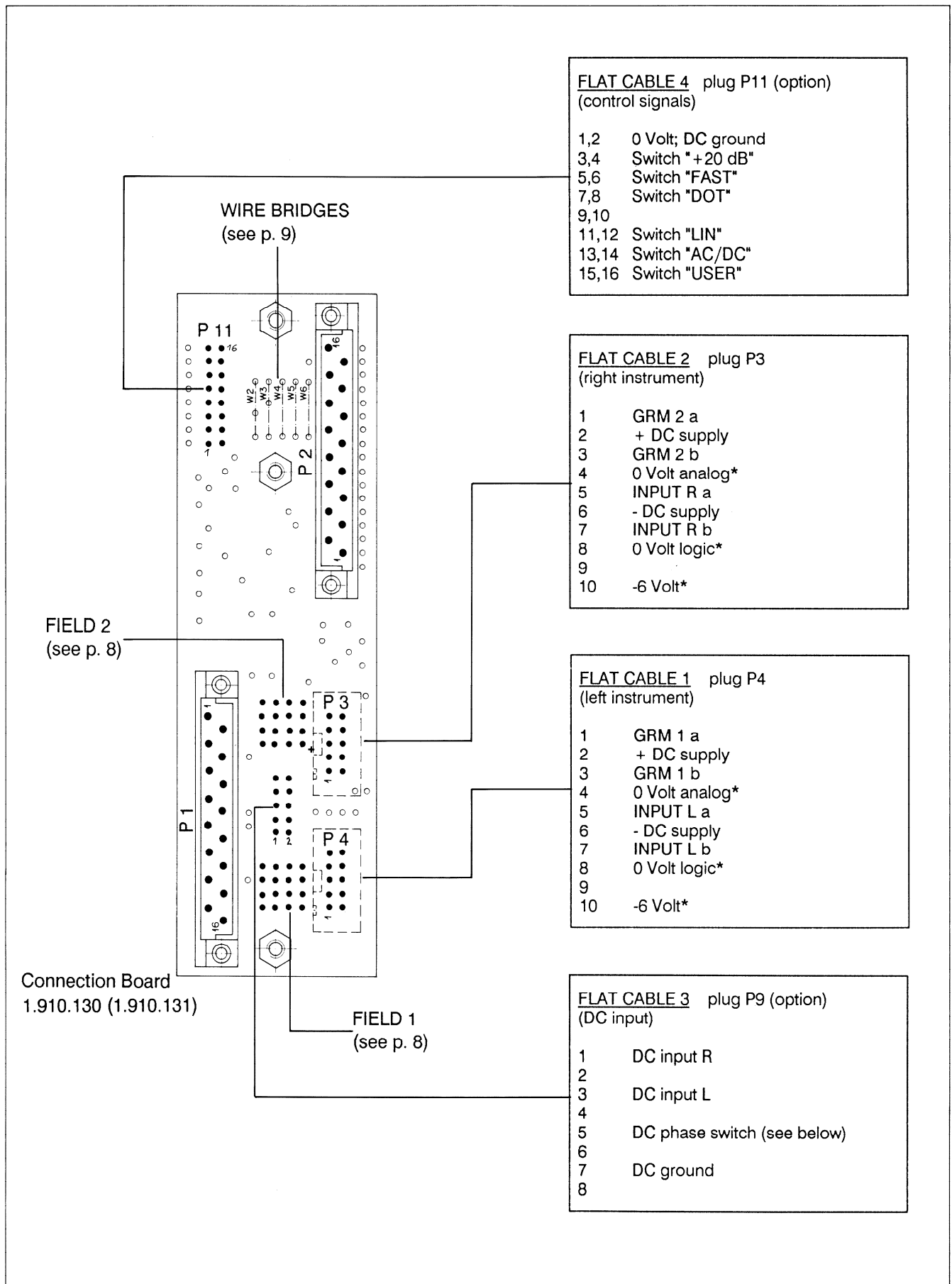

BARGRAPH

If the unit is powered by an unstabilized DC supply, an additional C may be installed (1000 μ F, 40 Volt, Order No. 59.22.6102).

Signals marked with an asterisk (*) are not required for the bargraph.

The lines carrying the AC bargraph input and the GRM input signals may also be soldered to the unit (instead of feeding those signals via the flat cables; especially useful for operation outside STUDER mixers). The connection points are:

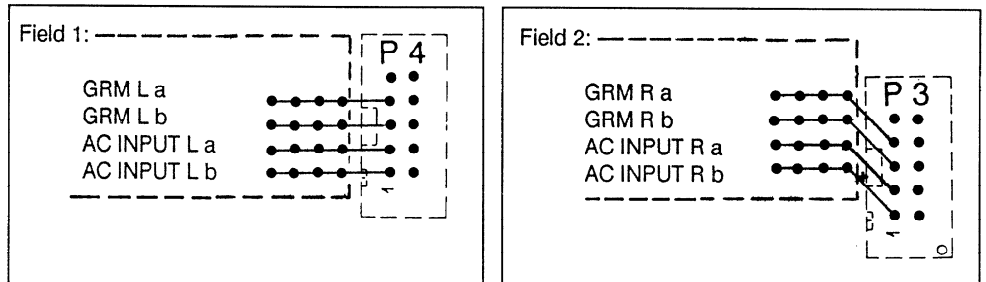

DC Supply

DC can be fed either via flat cable 1 or 2 or directly to the pins marked "+" and "-".

3.3 Function Settings

Some functions can be set both by wire bridges and by external switches. Do not duplicate!

Wire Bridges

BRIDGE	ON	OFF	
W2	■	■	INSTRUMENT ATTACK TIME 0.1 ms STANDARD ATTACK TIME (10 ms in PPM mode)
W3	■	■	GRM INDICATION AS SINGLE DOT GRM INDICATION AS BAR
W4			(reserved for future use)
W5 W6		■ ■	PPM INDICATION
W5 W6	■	■	VU INDICATION
W5 W6		■	DC LOG INDICATION
W5 W6	■	■	DC LIN INDICATION

External Switches

"ON" means that either the pin is connected to ground (pin 1/2) or that a TTL low level is connected. "OFF" means that either the switch is open (internal pull-up resistor) or that a TTL high level is connected.

All external switches are connected via flat cable 4 (see above).

PIN	ON	OFF	
1,2			0 VOLT
3,4	■	■	AC GAIN +20 dB AC GAIN 0 dB
5,6	■	■	INSTRUMENT ATTACK TIME 0.1 ms STANDARD ATTACK TIME (10 ms in PPM mode)
7,8	■	■	GRM INDICATION AS SINGLE DOT GRM INDICATION AS BAR
11,12	■	■	LIN INDICATION (if DC selected), VU INDICATION (if AC selected, see 13/14) LOG INDICATION (if DC selected), PPM INDICATION (if AC selected, see 13/14)
13,14	■	■	DC AC
15,16	■	■	USER SWITCH: LED ON FRONT PLATE ON LED ON FRONT PLATE OFF

BARGRAPH

4. Block Diagram

Block Diagram for Channel I

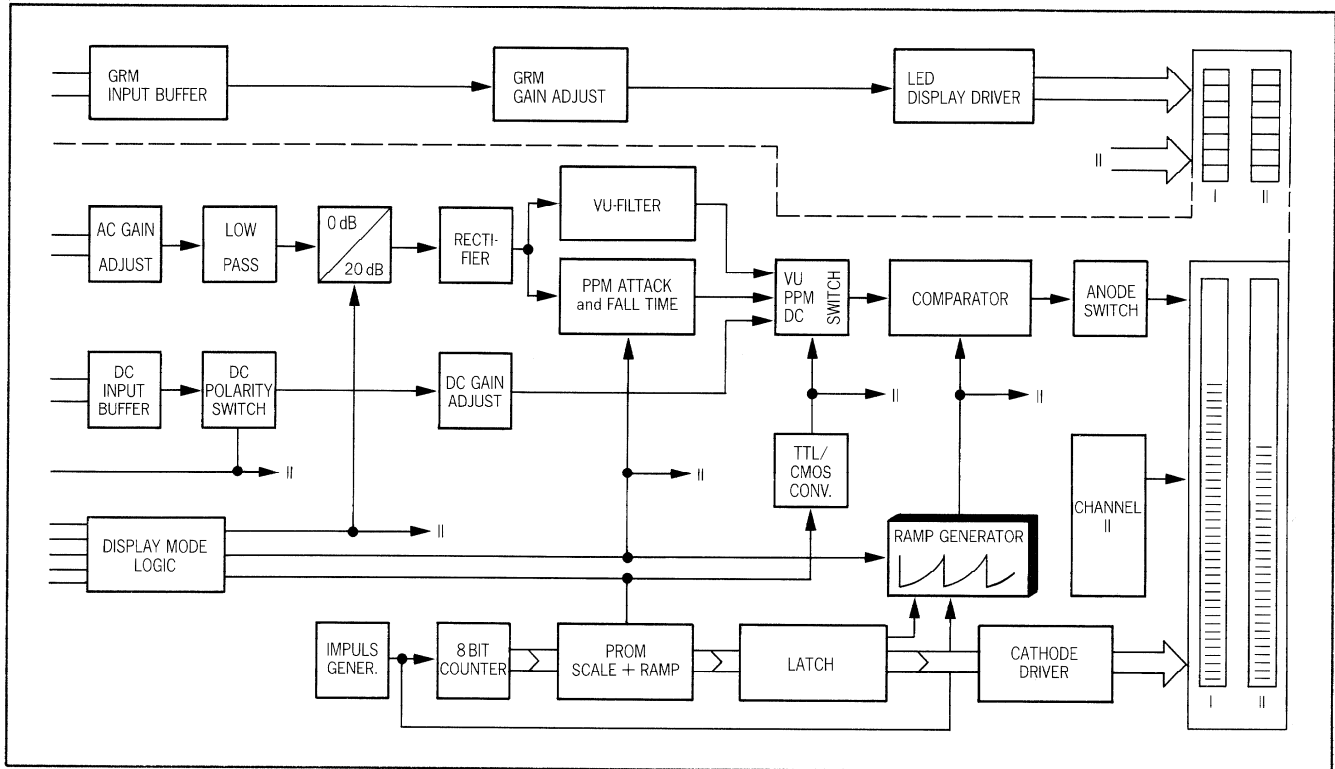

5. SCHEMATICS

1. **Bar Graph 1 Unit (VU or PPM)**
 - General..... 1.913.111 / 112
 - Display Board..... 1.913.119
 - Connection Board 1.910.130

2. **Bar Graph 4 Units (VU or PPM)**
 - General..... 1.913.411 / 412
 - Display Board..... 1.913.419
 - Connection Board 1.910.131

3. **Dual Bargraph circuit diagram..... 1.913.111/112**
 - Digital Board (1 Unit and 4 Units)..... 1.913.117
 - Analog Board (1 Unit and 4 Units) 1.913.118

Bargraph 1 Unit (PPM or VU) 1.913.111.81 / 112.81

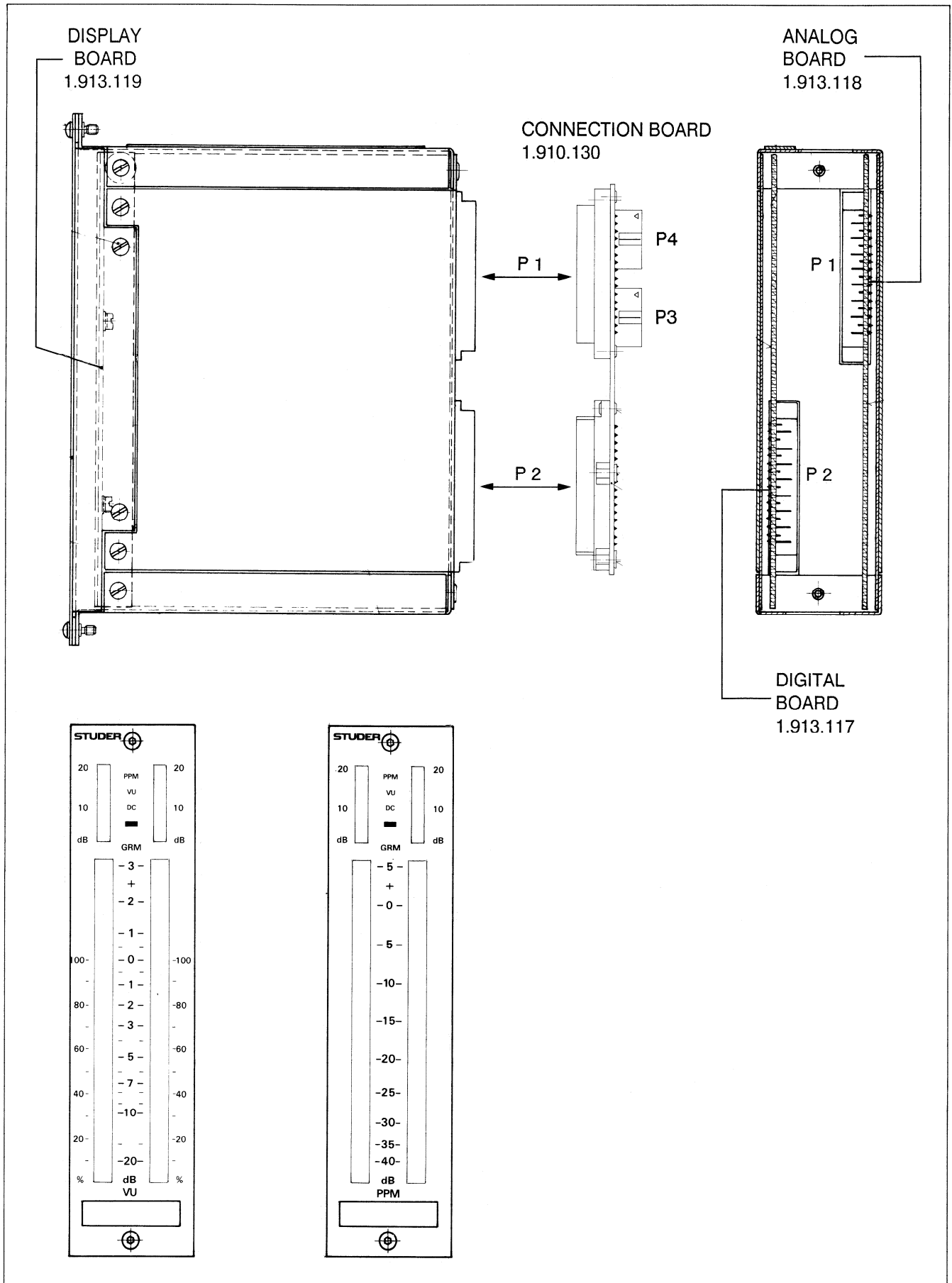

BARGRAPH

Display Board 1 Unit 1.913.119.00

Bestückungsseite

Lötseite

IND.	POS.NO.	PART NO.	VALUE	SPECIFICATIONS / EQUIVALENT	MANUF.
B.....1		89.01.4800		PLASMA-BAR-GRAPH 200 BARS, 5 PHASES	
C.....1			not used		
C.....2		59.31.8333	33 nF	+5% 400V MPC	
C.....3			not used		
DL.....1		50.04.2119	MV57124	red	
DL.....2		50.04.2119	MV57124	red	
DL.....3		50.04.2119	MV57124	red	
DL.....4		50.04.2119	MV57124	red	
DLZ...1		50.04.2150		led bar-graph red	
DLZ...2		50.04.2150		led bar-graph red	
IC....1		50.11.0119	LM3914N	led bar driver linear	NS
IC....2		50.11.0119	LM3914N	led bar driver linear	NS
L.....1		62.03.0005	250uH	coil	
L.....2		62.03.0005	250uH	coil	
MP....1		53.03.0175	2 pcs	IC-socket 18 pin	
MP....2		1.913.119.11	1 pcs	Print	
MP....3		1.913.111.03	1 pcs	Chassis 1E	0
MP....4		1.913.111.07	1 pcs	Isolation 1E	
MP....5		21.01.0352	2 pcs	Zylinder-schrauben M3x4	
MP....6		24.16.1030	2 pcs	Schnorr M3	
MP....7		23.01.1032	2 pcs	Unterlagsscheiben M3	
P.....5		54.01.0215		Cis Stecker 12 Pol	
P.....6		54.01.0241		Cis Stecker 4 Pol	
P.....7		54.01.0294		Cis Stecker 16 Pol	
P.....8		54.01.0289		Cis Stecker 8 Pol	
R.....1		57.11.3472	4.7 kOhm	5% 0.25W	
R.....2		57.11.3242	2.4 kOhm	5% 0.25W	
R.....3		57.11.3472	4.7 kOhm	5% 0.25W	
R.....4		57.11.3105	1 MOhm	5% 0.25W	

STUDER (00) 87/11/24 AE DISPLAY UNIT 1E PL 1.913.119.00 PAGE 1

IND.	POS.NO.	PART NO.	VALUE	SPECIFICATIONS / EQUIVALENT	MANUF.
MANUFACTURER: Bu=Burdny, Ex=Exer, Fc=Fairchild, GI=General Instrument, HP=Hewlett Packard, IIT=Intermetall, Mot=Motorola, Nat=National (Matsushita), NS=National Semiconductors, Ph=Philips, Ra=Raytheon, Sig=Signetics, Six=Siliconix, St=Studer, TI=Texas Instrument, Si=Siemens, Ie=Intersil, Un=Unitrode					

ORIG 87/11/24
STUDER (00) 87/11/24 AE DISPLAY UNIT 1E PL 1.913.119.00 PAGE 2

Bargraph Connection Board 1 Unit 1.913.130.00

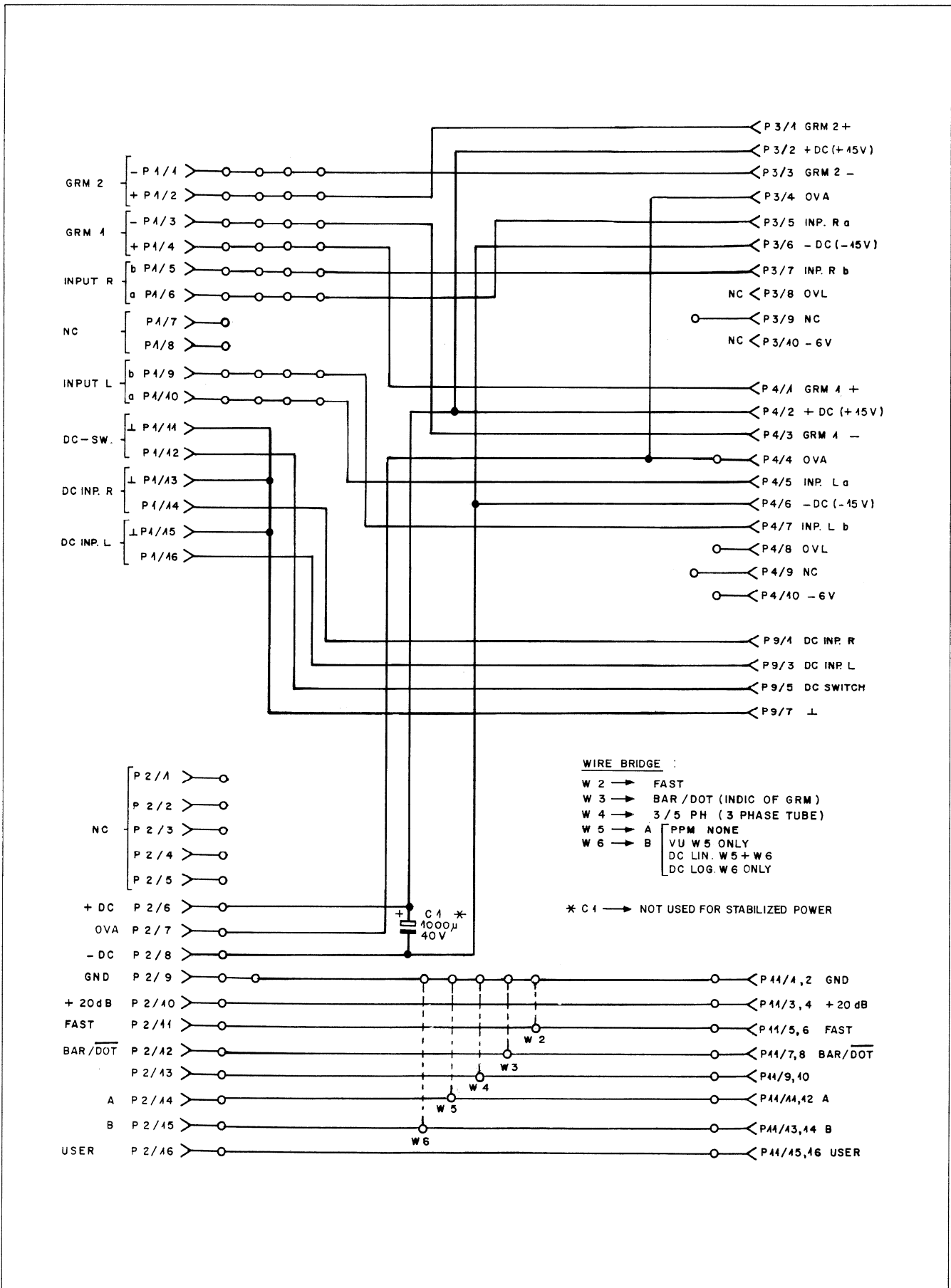

BARGRAPH

Bargraph Connection Board 1 Unit 1.913.130.00

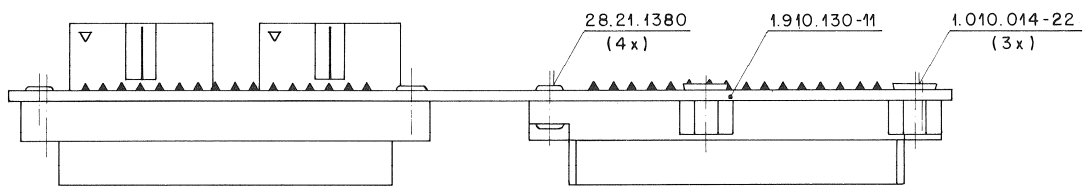
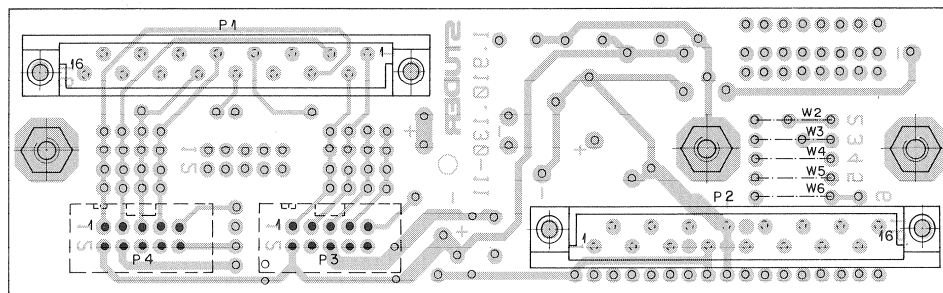

W2 bis W6 nach Angabe Studio-Projektierung

Bargraph 4 Units (PPM or VU) 1.913.411.81 / 412.81

DISPLAY BOARD
1.913.419

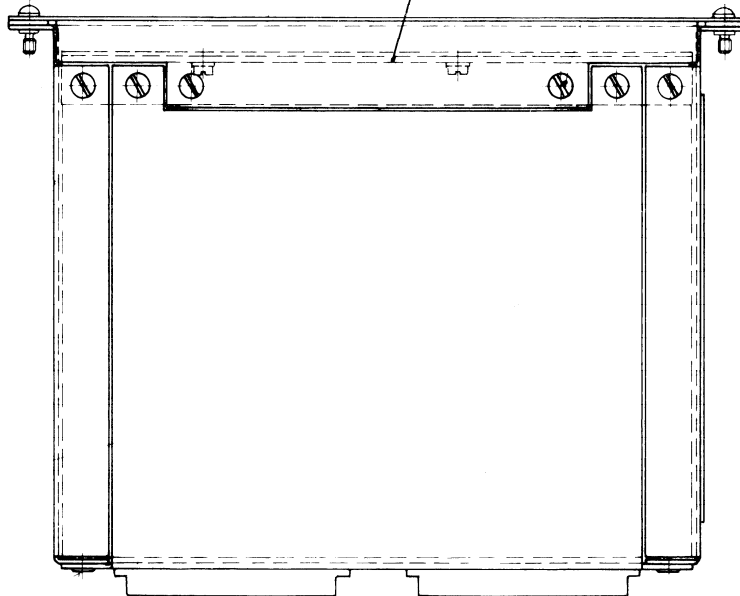

CONNECTION BOARD
1.910.131

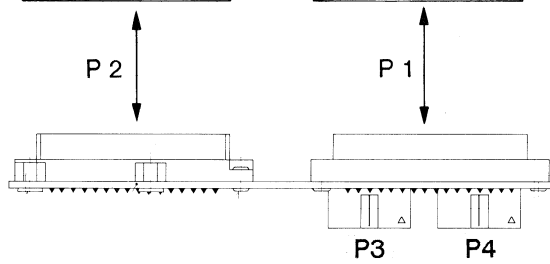

DIGITAL BOARD
1.913.117

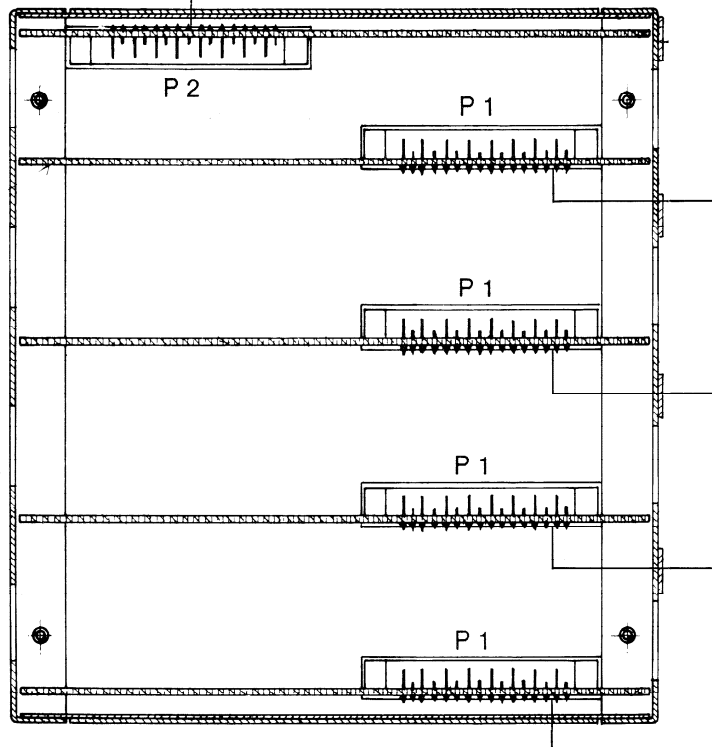

ANALOG BOARD
1.913.118

BARGRAPH

Display Board 4 Units 1.913.419.00

The Display Board 4 Units is adequate to four display boards for one unit each.
For details see schematic number 1.913.119.

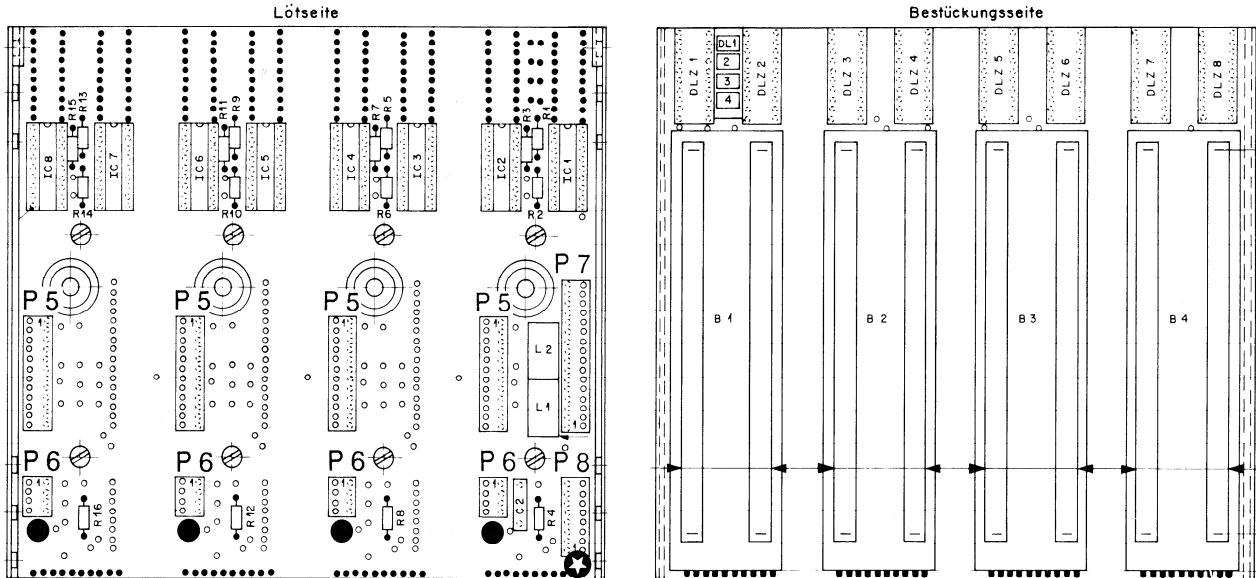

- ANALOG BOARD
1.913.118
- ★ DIGITAL BOARD
1.913.117

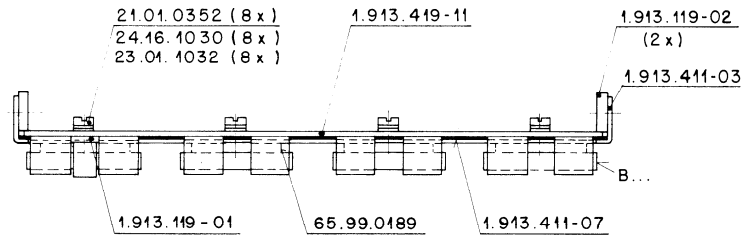

Bargraph Connection Board 4 Units 1.910.131

This Board combines four connection boards for one unit on a single print.
For details please see 'Connection Board 1 Unit 1.910.130'.

IND.	POS.NO.	PART NO.	VALUE	SPECIFICATIONS / EQUIVALENT	MANUF.	IND.	POS.NO.	PART NO.	VALUE	SPECIFICATIONS / EQUIVALENT	MANUF.
B....1		89.01.4800		PLASMA-BAR-GRAPH 200 BARS, 5 PHASES		MP....3			1 pcs	Chassis 4E	
B....2		89.01.4800		PLASMA-BAR-GRAPH 200 BARS, 5 PHASES		MP....4			1 pcs	Isolation 4E	
B....3		89.01.4800		PLASMA-BAR-GRAPH 200 BARS, 5 PHASES		MP....5	21.01.0352		2 pcs	Zylinderschrauben NS44	
B....4		89.01.4800		PLASMA-BAR-GRAPH 200 BARS, 5 PHASES		MP....6	24.16.1030		2 pcs	Schraur NS	
C....1			not used			MP....7	23.01.1032		2 pcs	Unterlagscheiben NS	
C....2		59.31.8333	33 nF	+-5% 400V MFC		P....5	54.01.0215			Cia Stecker 12 Pol	4 Stueck
C....3			not used			P....6	54.01.0241			Cia Stecker 4 Pol	4 Stueck
DL....1		50.04.2119	MV57124	red		P....7	54.01.0294			Cia Stecker 16 Pol	1 Stueck
DL....2		50.04.2119	MV57124	red		P....8	54.01.0289			Cia Stecker 8 Pol	1 Stueck
DL....3		50.04.2119	MV57124	red		R....1	57.11.3472	4.7 kOhm	5%	0.25W	
DL....4		50.04.2119	MV57124	red		R....2	57.11.3242	2.4 kOhm	5%	0.25W	
DLZ...1		50.04.2150		led bar-graph red		R....3	57.11.3472	4.7 kOhm	5%	0.25W	
DLZ...2		50.04.2150		led bar-graph red		R....4	57.11.3105	1 MOhm	5%	0.25W	
DLZ...3		50.04.2150		led bar-graph red		R....5	57.11.3472	4.7 kOhm	5%	0.25W	
DLZ...4		50.04.2150		led bar-graph red		R....6	57.11.3242	2.4 kOhm	5%	0.25W	
DLZ...5		50.04.2150		led bar-graph red		R....7	57.11.3472	4.7 kOhm	5%	0.25W	
DLZ...6		50.04.2150		led bar-graph red		R....8	57.11.3105	1 MOhm	5%	0.25W	
DLZ...7		50.04.2150		led bar-graph red		R....9	57.11.3472	4.7 kOhm	5%	0.25W	
DLZ...8		50.04.2150		led bar-graph red		R....10	57.11.3242	2.4 kOhm	5%	0.25W	
IC....1		50.11.0119	LM3914N	led bar driver linear	NS	R....11	57.11.3472	4.7 kOhm	5%	0.25W	
IC....2		50.11.0119	LM3914N	led bar driver linear	NS	R....12	57.11.3105	1 MOhm	5%	0.25W	
IC....3		50.11.0119	LM3914N	led bar driver linear	NS	R....13	57.11.3472	4.7 kOhm	5%	0.25W	
IC....4		50.11.0119	LM3914N	led bar driver linear	NS	R....14	57.11.3242	2.4 kOhm	5%	0.25W	
IC....5		50.11.0119	LM3914N	led bar driver linear	NS	R....15	57.11.3472	4.7 kOhm	5%	0.25W	
IC....6		50.11.0119	LM3914N	led bar driver linear	NS	R....16	57.11.3105	1 MOhm	5%	0.25W	
IC....7		50.11.0119	LM3914N	led bar driver linear	NS						
IC....8		50.11.0119	LM3914N	led bar driver linear	NS						
L....1		62.03.0005	250uH	coil							
L....2		62.03.0005	250uH	coil							
MP....1		53.03.0175	8 pcs	IC-socket 18 pin							
MP....2		1.913.419.11	1 pcs	Print							

MANUFACTURER: Bu=Burndy, Ex=Exar, Fc=Fairchild, G=General Instrument
 HP=Hewlett Packard, ITT=International, Mot=Motorola, Nat=National
 (Matsushita), NS=National Semiconductors, Ph=Philips,
 Ra=Raytheon, Sig=Signetics, Six=Siiconix, St=Studer,
 TI=Texas Instrument, S=Siemens, In=Intersil, Un=Unitecra

ORIG 87/11/24

S T U D E R (00) 87/11/24 AE DISPLAY UNIT 4E PL 1.913.419.00 PAGE 1 S T U D E R (00) 87/11/24 AE DISPLAY UNIT 4E PL 1.913.419.00 PAGE 2

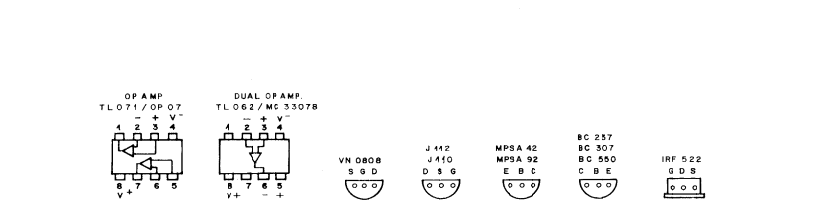
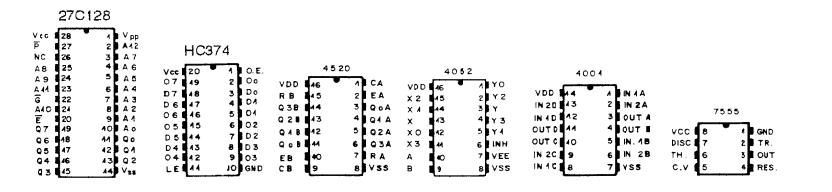
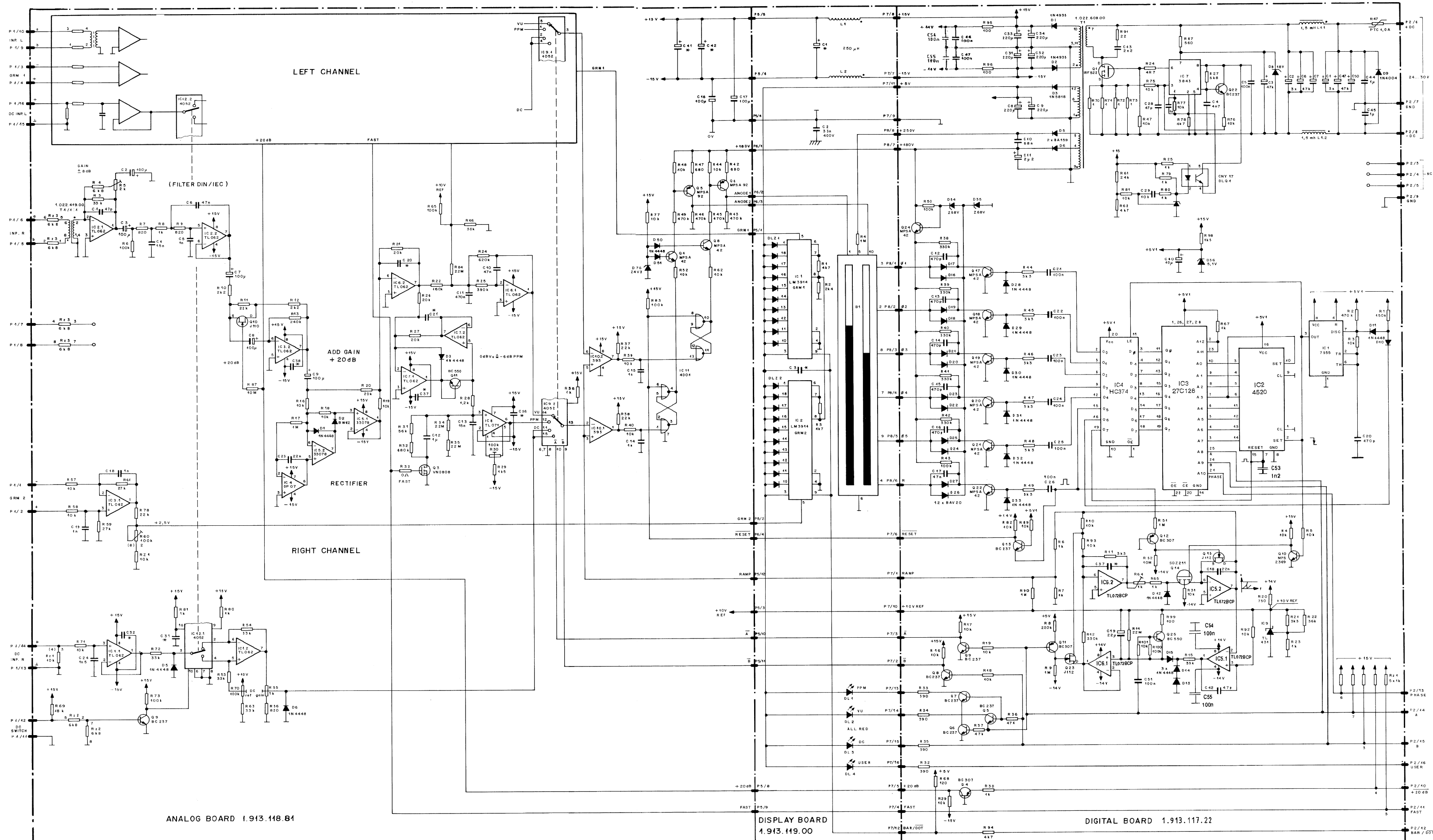

ANALOG BOARD 1.913.118.81

DISPLAY BOARD 1.913.119.00

DIGITAL BOARD 1.913.117.22

REGISDORF ZÜRICH	DUAL BAR GRAPH PPM	SC 1.913.111.81
	DUAL BAR GRAPH VU	SC 1.913.112.81

BARGRAPH



Bargraph Digital Board 1.913.117.21

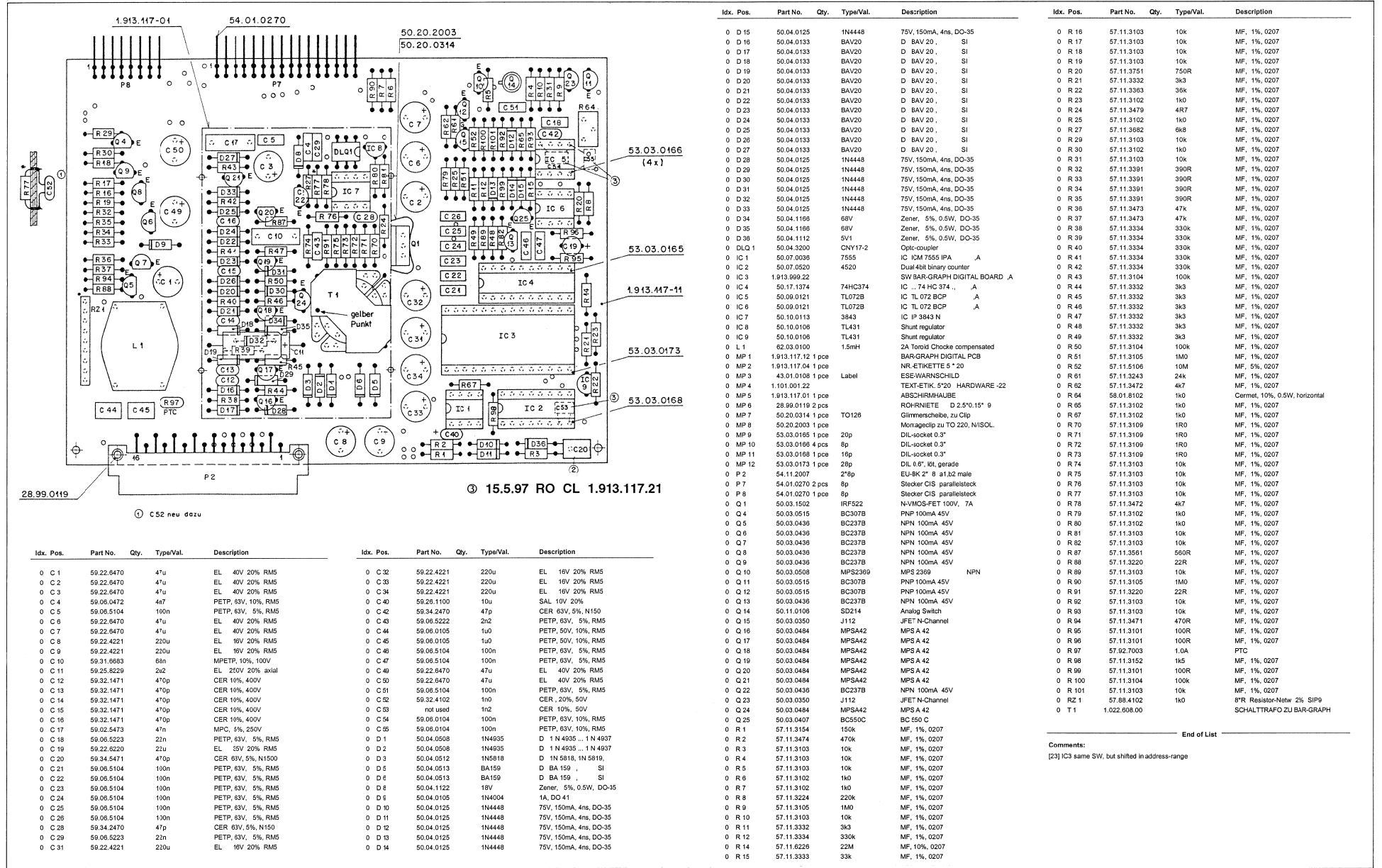

Idx. Pos.	Part No.	Qty.	Type/Val.	Description	Idx. Pos.	Part No.	Qty.	Type/Val.	Description
0 D 15	50.04.0125	1N4448		75V, 150mA, 4ns, DO-35	0 R 18	57.11.3103	10k		MF, 1%, 0207
0 D 16	50.04.0133	BAV20		D BAV 20, SI	0 R 17	57.11.3103	10k		MF, 1%, 0207
0 D 17	50.04.0133	BAV20		D BAV 20, SI	0 R 18	57.11.3103	10k		MF, 1%, 0207
0 D 18	50.04.0133	BAV20		D BAV 20, SI	0 R 19	57.11.3103	10k		MF, 1%, 0207
0 D 19	50.04.0133	BAV20		D BAV 20, SI	0 R 20	57.11.3751	750R		MF, 1%, 0207
0 D 20	50.04.0133	BAV20		D BAV 20, SI	0 R 21	57.11.3332	3k3		MF, 1%, 0207
0 D 21	50.04.0133	BAV20		D BAV 20, SI	0 R 22	57.11.3363	38k		MF, 1%, 0207
0 D 22	50.04.0133	BAV20		D BAV 20, SI	0 R 23	57.11.3102	1k0		MF, 1%, 0207
0 D 23	50.04.0133	BAV20		D BAV 20, SI	0 R 24	57.11.3479	47R7		MF, 1%, 0207
0 D 24	50.04.0133	BAV20		D BAV 20, SI	0 R 25	57.11.3102	1k0		MF, 1%, 0207
0 D 25	50.04.0133	BAV20		D BAV 20, SI	0 R 27	57.11.3682	68k		MF, 1%, 0207
0 D 26	50.04.0133	BAV20		D BAV 20, SI	0 R 29	57.11.3103	10k		MF, 1%, 0207
0 D 27	50.04.0133	BAV20		D BAV 20, SI	0 R 30	57.11.3102	1k0		MF, 1%, 0207
0 D 28	50.04.0125	1N4448		75V, 150mA, 4ns, DO-35	0 R 31	57.11.3103	10k		MF, 1%, 0207
0 D 29	50.04.0125	1N4448		75V, 150mA, 4ns, DO-35	0 R 32	57.11.3391	390R		MF, 1%, 0207
0 D 30	50.04.0125	1N4448		75V, 150mA, 4ns, DO-35	0 R 33	57.11.3391	390R		MF, 1%, 0207
0 D 31	50.04.0125	1N4448		75V, 150mA, 4ns, DO-35	0 R 34	57.11.3391	390R		MF, 1%, 0207
0 D 32	50.04.0125	1N4448		75V, 150mA, 4ns, DO-35	0 R 35	57.11.3391	390R		MF, 1%, 0207
0 D 33	50.04.0125	1N4448		75V, 150mA, 4ns, DO-35	0 R 37	57.11.3473	47k		MF, 1%, 0207
0 D 34	50.04.1168	68V		Zener, 5%, 0.5W, DO-35	0 R 37	57.11.3473	47k		MF, 1%, 0207
0 D 35	50.04.1168	68V		Zener, 5%, 0.5W, DO-35	0 R 38	57.11.3334	330k		MF, 1%, 0207
0 D 36	50.04.1112	5V1		Zener, 5%, 0.5W, DO-35	0 R 39	57.11.3334	330k		MF, 1%, 0207
0 DLQ 1	50.04.3200	CNY17-2		Opto-coupler	0 R 40	57.11.3334	330k		MF, 1%, 0207
0 IC 1	50.07.0039	7555		IC LM7555 IPA A	0 R 41	57.11.3334	330k		MF, 1%, 0207
0 IC 2	50.07.0520	4520		Dual 4-bit binary counter	0 R 42	57.11.3334	330k		MF, 1%, 0207
0 IC 3	1.913.999.22			SW BAR-GRAPH DIGITAL BOARD A	0 R 43	57.11.3104	100k		MF, 1%, 0207
0 IC 4	50.17.1374	74HC374		IC -74 HC 374, A	0 R 44	57.11.3332	3k3		MF, 1%, 0207
0 IC 5	50.09.0121	TL072B		IC TL072 BCP A	0 R 45	57.11.3332	3k3		MF, 1%, 0207
0 IC 6	50.09.0121	TL072B		IC TL072 BCP A	0 R 46	57.11.3332	3k3		MF, 1%, 0207
0 IC 7	50.10.0113	3843		IC P 3843 N	0 R 47	57.11.3332	3k3		MF, 1%, 0207
0 IC 8	50.10.0108	TL431		Shunt regulator	0 R 48	57.11.3332	3k3		MF, 1%, 0207
0 IC 9	50.10.0108	TL431		Shunt regulator	0 R 49	57.11.3332	3k3		MF, 1%, 0207
0 P 1	50.03.0126	2A		2A Tantalum Capacitor compensated	0 R 50	57.11.3102	1k0		MF, 1%, 0207
0 MP 1	1.913.117.12	1 pce		BA-GRAPH DIGITAL PCB	0 R 51	57.11.3103	10k		MF, 1%, 0207
0 MP 2	1.913.117.04	1 pce		NR-ETIKETTE 5 * 20	0 R 52	57.11.5106	10M		MF, 5%, 0207
0 MP 3	43.01.0108	1 pce		Label	0 R 51	57.11.3243	24k		MF, 1%, 0207
0 MP 4	1.101.001.22	1 pce		TEXT-ETIK. 5*20 HARDWARE -22	0 R 62	57.11.3472	4k7		MF, 1%, 0207
0 MP 5	1.913.117.01	1 pce		ABSCHIRMHAUBE	0 R 64	58.01.8102	1k0		Carmer, 10%, 0.5W, horizontal
0 MP 6	28.99.0119	2 pcs		ROHRNETE D 2.5*10*15 9	0 R 65	57.11.3102	1k0		MF, 1%, 0207
0 MP 7	50.20.0314	1 pce		Dimmermodule, zu Clp	0 R 67	57.11.3102	1k0		MF, 1%, 0207
0 MP 8	50.20.2003	1 pce		Montagesch. zu T20, N150L	0 R 70	57.11.3109	1R0		MF, 1%, 0207
0 MP 9	53.03.0165	1 pce		20p	0 R 71	57.11.3109	1R0		MF, 1%, 0207
0 MP 10	53.03.0168	4 pcs		8p	0 R 72	57.11.3109	1R0		MF, 1%, 0207
0 MP 11	53.03.0168	1 pce		16p	0 R 73	57.11.3109	1R0		MF, 1%, 0207
0 MP 12	53.03.0173	1 pce		28p	0 R 74	57.11.3103	10k		MF, 1%, 0207
0 P 2	54.11.2007	2*8p		EU-BK 2 * 8 at 12 male	0 R 75	57.11.3103	10k		MF, 1%, 0207
0 P 7	54.01.0270	2 pcs		Stecker C15 parallelsteck	0 R 76	57.11.3103	10k		MF, 1%, 0207
0 P 8	54.01.0270	1 pce		Stecker C15 parallelsteck	0 R 77	57.11.3103	10k		MF, 1%, 0207
0 Q 1	50.03.1502	IRF522		N-VMO5-FET 100V, 7A	0 R 78	57.11.3472	4k7		MF, 1%, 0207
0 Q 4	50.03.0515	BC307B		PNP 100mA 45V	0 R 79	57.11.3102	1k0		MF, 1%, 0207
0 Q 5	50.03.0438	BC237B		NPN 100mA 45V	0 R 80	57.11.3102	1k0		MF, 1%, 0207
0 Q 6	50.03.0438	BC237B		NPN 100mA 45V	0 R 81	57.11.3103	10k		MF, 1%, 0207
0 Q 7	50.03.0438	BC237B		NPN 100mA 45V	0 R 82	57.11.3103	10k		MF, 1%, 0207
0 Q 8	50.03.0438	BC237B		NPN 100mA 45V	0 R 87	57.11.3561	560R		MF, 1%, 0207
0 Q 9	50.03.0438	BC237B		NPN 100mA 45V	0 R 88	57.11.3220	22R		MF, 1%, 0207
0 Q 10	50.03.0508	NPS2369		NPN	0 R 89	57.11.3103	10k		MF, 1%, 0207
0 Q 11	50.03.0515	BC307B		PNP 100mA 45V	0 R 90	57.11.3105	1M0		MF, 1%, 0207
0 Q 12	50.03.0515	BC307B		PNP 100mA 45V	0 R 91	57.11.3220	22R		MF, 1%, 0207
0 Q 13	50.03.0438	BC237B		NPN 100mA 45V	0 R 92	57.11.3103	10k		MF, 1%, 0207
0 Q 14	50.11.0108	SD214		Analog Switch	0 R 93	57.11.3103	10k		MF, 1%, 0207
0 Q 15	50.03.0350	J112		JFET N-Channel	0 R 94	57.11.3471	470R		MF, 1%, 0207
0 Q 16	50.03.0484	MPSA42		MPSA 42	0 R 96	57.11.3101	100R		MF, 1%, 0207
0 Q 17	50.03.0484	MPSA42		MPSA 42	0 R 96	57.11.3101	100R		MF, 1%, 0207
0 Q 18	50.03.0484	MPSA42		MPSA 42	0 R 97	57.02.7003	1.0A		PTC
0 Q 19	50.03.0484	MPSA42		MPSA 42	0 R 98	57.11.3152	1k5		MF, 1%, 0207
0 Q 20	50.03.0484	MPSA42		MPSA 42	0 R 99	57.11.3101	100R		MF, 1%, 0207
0 Q 21	50.03.0484	MPSA42		MPSA 42	0 R 100	57.11.3104	100k		MF, 1%, 0207
0 Q 22	50.03.0438	BC237B		NPN 100mA 45V	0 R 101	57.11.3103	10k		MF, 1%, 0207
0 Q 23	50.03.0350	J112		JFET N-Channel	0 R 12	57.11.3103	10k		MF, 1%, 0207
0 Q 24	50.03.0484	MPSA42		MPSA 42	0 R 24	57.11.3102	1k0		MF, 1%, 0207
0 Q 25	50.03.0407	BC550C		BC 550 C	0 R 21	57.88.4102	1k0		BFR Resistor-Netz 21 S1PS
0 R 1	57.11.3154	150k		MF, 1%, 0207	0 T 1	1.022.606.00			SCHALTRAFO ZU BAR-GRAPH
0 R 2	57.11.3474	470k		MF, 1%, 0207					
0 R 3	57.11.3103	10k		MF, 1%, 0207					
0 R 4	57.11.3103	10k		MF, 1%, 0207					
0 R 5	57.11.3103	10k		MF, 1%, 0207					
0 R 6	57.11.3102	1k0		MF, 1%, 0207					
0 R 7	57.11.3102	1k0		MF, 1%, 0207					
0 R 8	57.11.3224	220k		MF, 1%, 0207					
0 R 9	57.11.3105	1M0		MF, 1%, 0207					
0 R 10	57.11.3103	10k		MF, 1%, 0207					
0 R 11	57.11.3332	3k3		MF, 1%, 0207					
0 R 12	57.11.3334	330k		MF, 1%, 0207					
0 R 14	57.11.8226	22M		MF, 10%, 0207					
0 R 15	57.11.3333	33k		MF, 1%, 0207					

Comments:
[23] IC3 same SW, but shifted in address-range

End of List

AUX. Indicator Unit 1.913.130

Die vier Instrumente zeigen dauernd die Modulation der Hilfsausgänge AUX 1... 4 an. Um eine Uebereinstimmung mit dem Hauptinstrument zu erzielen, ist eine Wahl zwischen VU- und PPM Charakteristik möglich. Die Instrumente sind von hinten beleuchtet. Das oberste Instrument kann die Mono-Mischung eines Stereokanals anzeigen (nur bei Mischpulten der Serie 900).

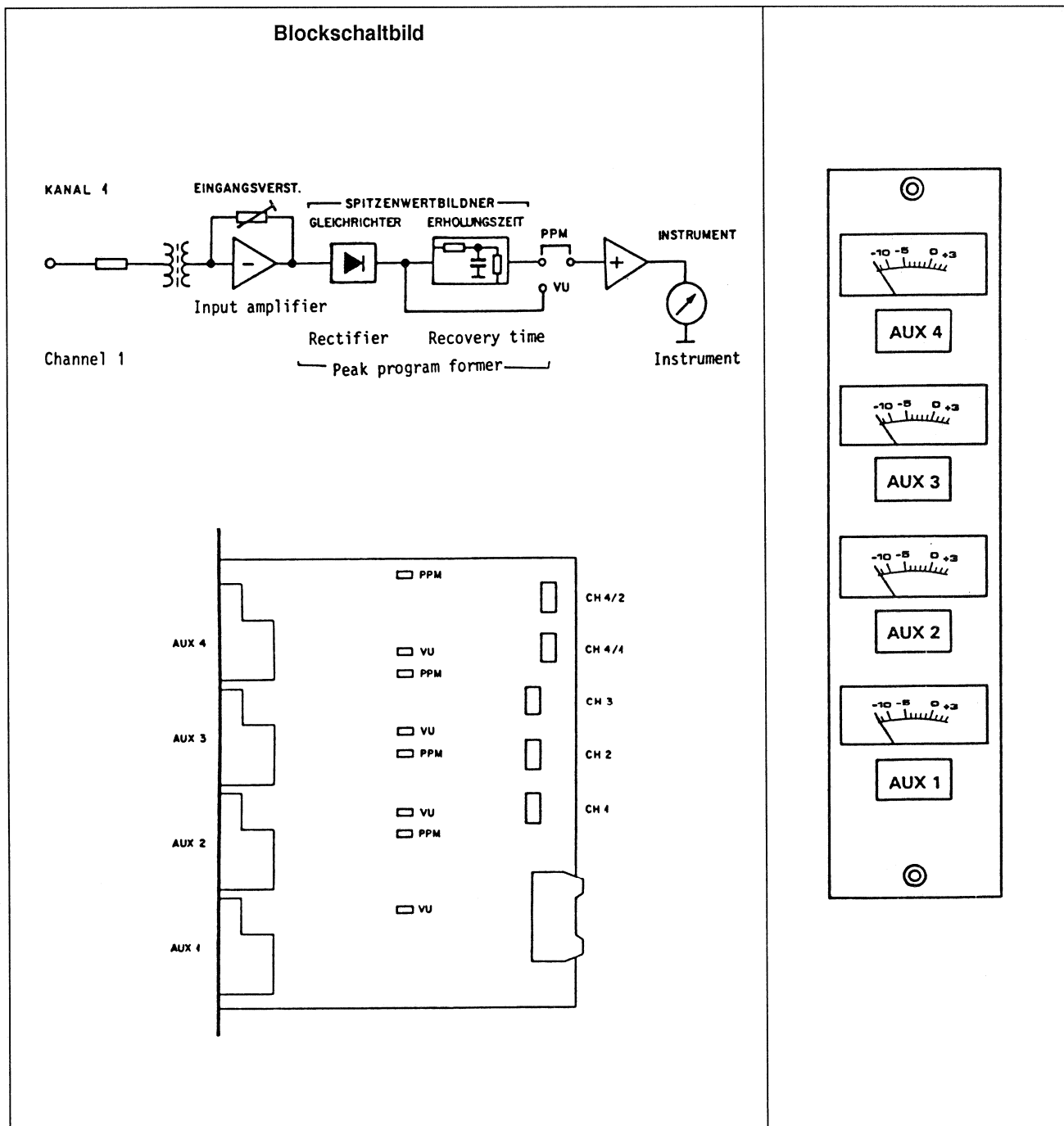

Fig. 1, 2, 3

1. Grundeinstellung

Wahl der Charakteristik

Brückenstecker auf den entsprechenden Stellen platzieren.

Charakteristik ist ebenfalls an der Lötseite der Printplatte bezeichnet mit:

V für VU und

P für PPM

2. Technische Daten

Speisespannungen:

+ 15 V	40 mA
- 15 V	40 mA
- 6 V	120 mA

Eingangswiderstand: $R_i > 10 \text{ k}\Omega$

Bereich: + 6 dBu ... + 15 dBu

Frequenzgang 30 Hz...15 kHz: - 1 dB

Dynamik:

PPM in Anlehnung an IEC 268 Norm.

Ansprechzeit in 10 ms auf ca. - 1 dB

Abfallzeit in 1,7 sec auf ca. - 20 dB

VU-Meter in Anlehnung an ANSI Norm.

Ansprechzeit in 200 ms auf ca. -1 VU

3. Mechanische Daten

Abmessungen Frontplatte: 170 x 40 mm

Tiefe: 135 mm

Gewicht: 200 g

AUX. Indicator Unit 1.913.130

The four instruments continuously indicate the modulation of the auxiliary outputs 1...4. To ensure that the readings correspond with those of the main instrument, a change-over between VU and PPM characteristic is possible. The instruments are illuminated from the back. The top instrument can indicate the mono-mix of a stereo-channel. (With audio consoles series 900 only).

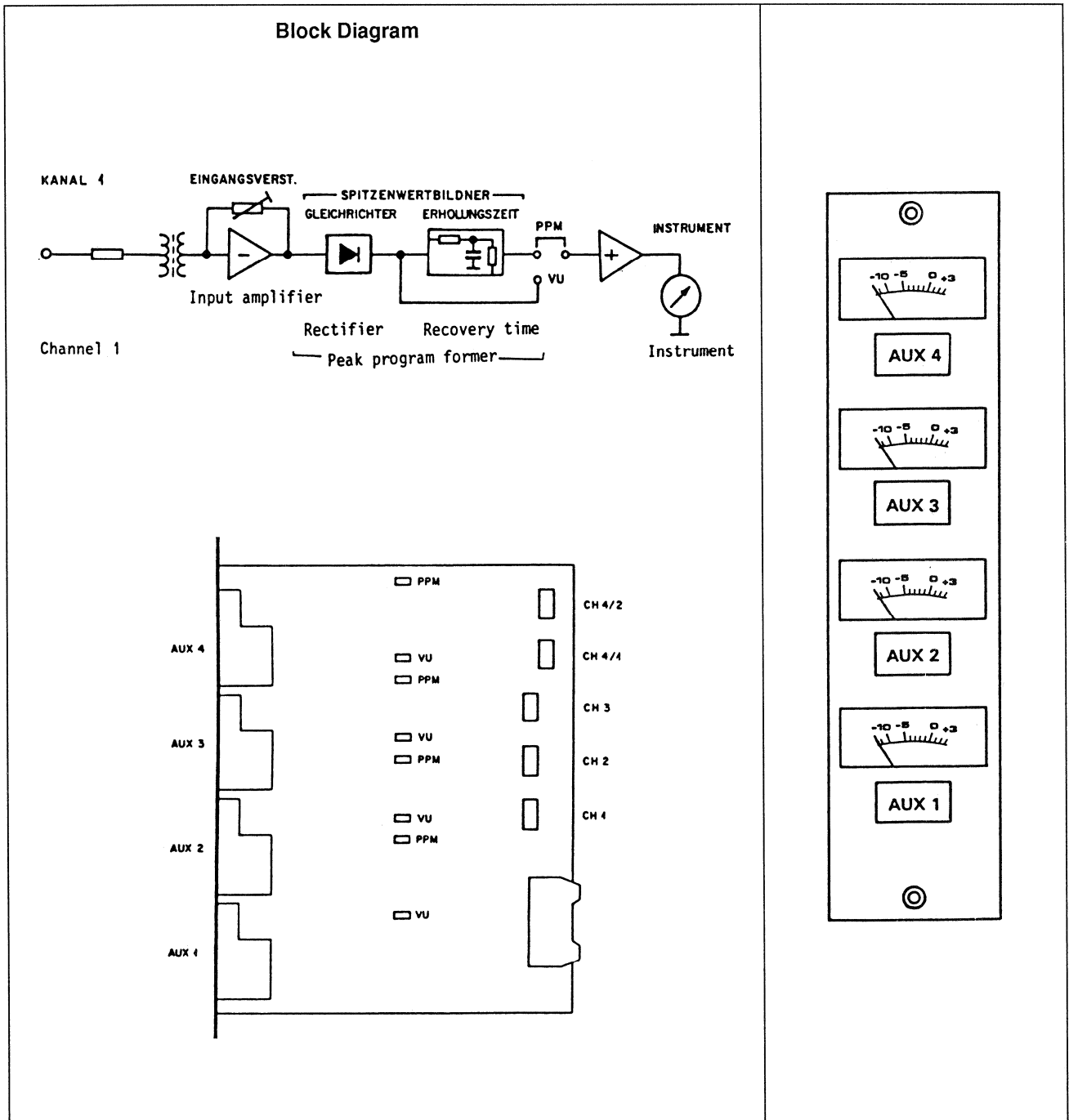

Fig. 1, 2, 3

1. Basic Setting

Selection of the characteristic

Insert jumper in the corresponding location.

The characteristic is also identified on the soldering side of the PCB with

V for VU and

P for PPM

2. Specifications

Supply voltages:	+ 15 V	40 mA
	- 15 V	40 mA
	- 6 V	120 mA

Input impedance: $R_i > 10 \text{ k}\Omega$

Range: + 6 dBu ... +15 dBu

Frequency response 30 Hz...15 kHz: -1 dB

Dynamic response:

PPM similar to IEC 268 standard.

Attack time 10 ms to ca.-1 dB

Return time 1,7 sec to ca.-20 dB

VU-Meter similar to ANSI standard.

Attack time 200 ms to ca.-1 VU

3. Physical Data

Dimensions of front panel: 170 x 40 mm

Depth: 135 mm

Weight: 200 g

AUX Indicator Unit 1.913.130.81

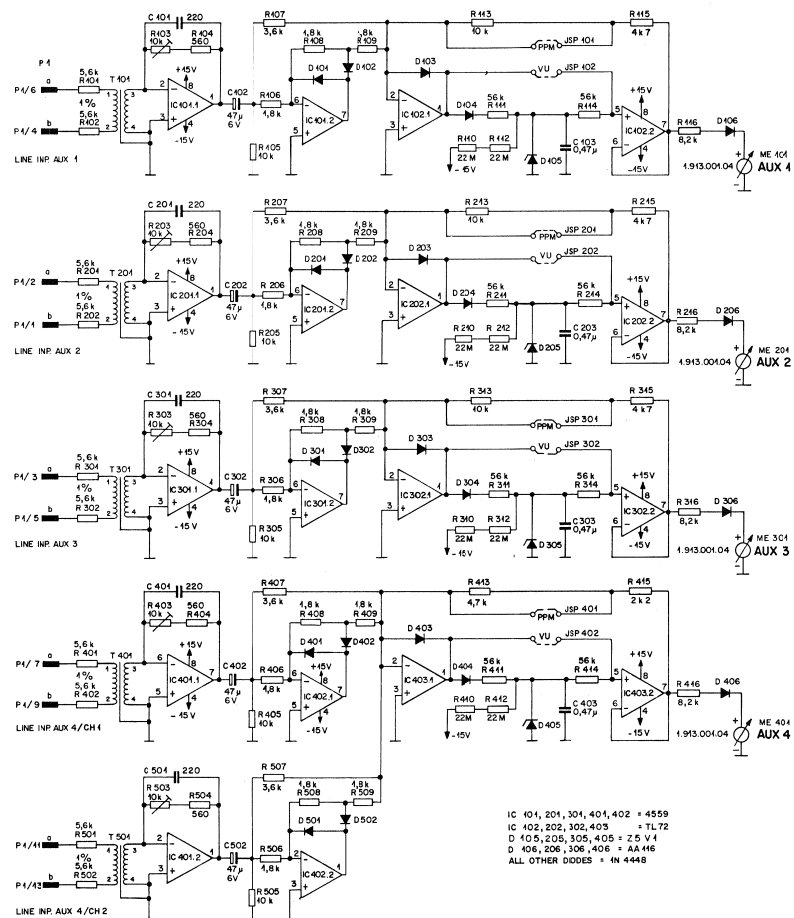

IC 401, 201, 301, 401, 402 + 4559
 IC 402, 202, 302, 403 + TL 72
 D 405, 205, 305, 405 + Z 5 V 4
 D 406, 206, 306, 406 + AA 416
 ALL OTHER DIODES + IN 4448

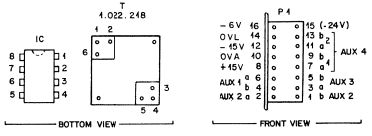
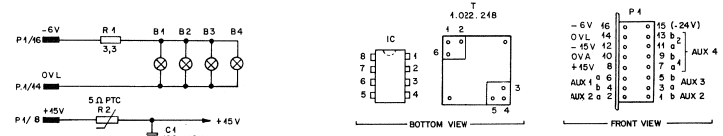

DATE:	30.8.81				
SIGN:	[Signature]				
STUDER REGENSRORF ZÜRICH		AUX. INDICATOR UNIT			SC. 1.913.130.81

AUX Indicator Unit 1.913.130.81

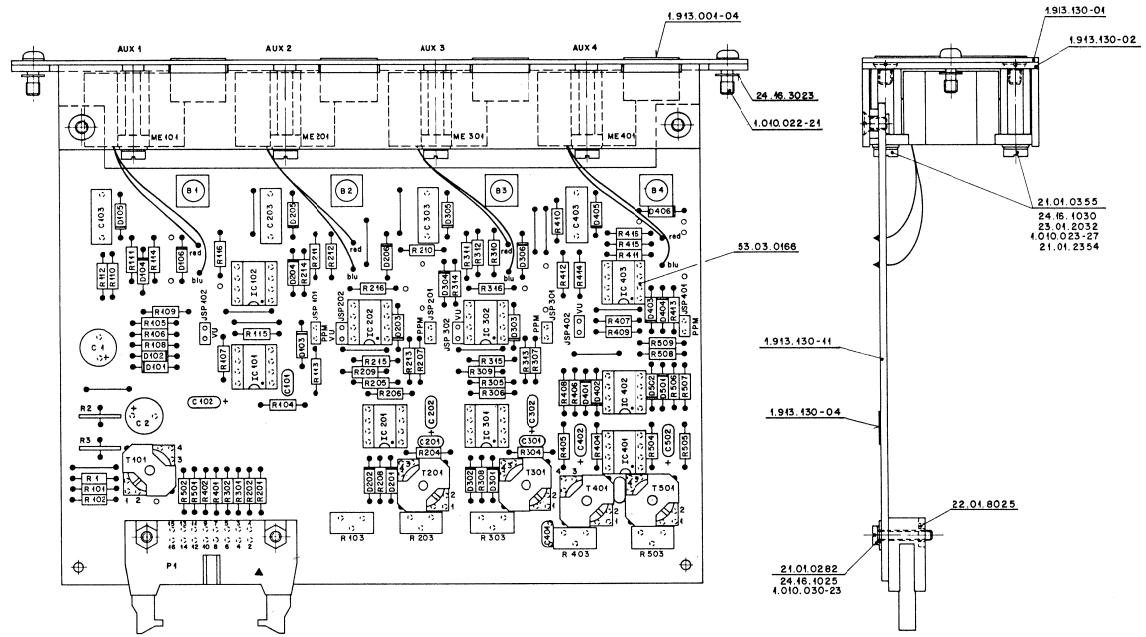

IND POS NO	PART NO	VALUE	SPECIFICATIONS/EQUIVALENT	MFR
C 1	53.22.5101	100µF 25V		EL
C 2	53.22.5101	100µF 25V		EL
C101	53.34.4221	220pF		CER
C102	53.26.0470	47µF 6V		EL
C103	53.02.0474	0.47µF 5%		PC
C201	53.34.4221	220pF		CER
C202	53.26.0470	47µF 6V		EL
C203	53.02.0474	0.47µF 5%		PC
C301	53.34.4221	220pF		CER
C302	53.26.0470	47µF 6V		EL
C303	53.02.0474	0.47µF 5%		PC
C401	53.34.4221	220pF		CER
C402	53.26.0470	47µF 6V		EL
C403	53.02.0474	0.47µF 5%		PC
C501	53.34.4221	220pF		CER
C502	53.26.0470	47µF 6V		EL
BA24	51.02.0144	6V .30mA		0
D101	50.04.0125	IN4448		SI
D102	50.04.0125	IN4448		SI
D103	50.04.0125	IN4448		SI
D104	50.04.0125	IN4448		SI
D105	50.04.1112	2D 5V1		SI
D106	50.04.0363	AA 116		GE S,Se

IND	DATE	NAME	
①		O - OSRAM	SI - SILICIUM
②		S - SIEMENS	GE - GERMANIUM
③		Se - SESCO	EL - ELECTROLYTIC
④			PC - POLYCARBONAT
⑤			CER - CERAMIC

STUDER AUX. INDICATOR 1.913.130.81 PAGE 1 OF 6

IND POS NO	PART NO	VALUE	SPECIFICATIONS/EQUIVALENT	MFR
D201	50.04.0125	IN4448		SI
D202	50.04.0125	IN4448		SI
D203	50.04.0125	IN4448		SI
D204	50.04.0125	IN4448		SI
D205	50.04.1112	2D 5V1		SI
D206	50.04.0363	AA 116		GE S,Se
D301	50.04.0125	IN4448		SI
D302	50.04.0125	IN4448		SI
D303	50.04.0125	IN4448		SI
D304	50.04.0125	IN4448		SI
D305	50.04.1112	2D 5V1		SI
D306	50.04.0363	AA 116		GE S,Se
D401	50.04.0125	IN4448		SI
D402	50.04.0125	IN4448		SI
D403	50.04.0125	IN4448		SI
D404	50.04.0125	IN4448		SI
D405	50.04.1112	2D 5V1		SI
D406	50.04.0363	AA 116		GE S,Se
D501	50.04.0125	IN4448		SI
D502	50.04.0125	IN4448		SI
J5P	54.01.0010	JUMPER PLUG		B
J5J	54.01.0024	JUMPER JACK		B
IC401	50.09.0107	ARCASSINB DUAL	OPA	RATI
IC402	50.09.0107	ARCASSINB DUAL	B1-JFET	LF 353 N TI

IND	DATE	NAME	
①		S - SIEMENS	SI - SILICIUM
②		Se - SESCO	GE - GERMANIUM
③		B - BERG	
④		T - TEXAS INSTR.	
⑤		R - RAYNEON	

STUDER AUX. INDICATOR 1.913.130.81 PAGE 2 OF 6

AUX Indicator Unit 1.913.130.81

INDI POS NO	PART NO	VALUE	SPECIFICATIONS/EQUIVALENT	MFR
IC 201	50.09.0107	RC4553NB	DUAL	RA, TI
IC 202	50.09.0101	72072ACP	DUAL BI-FET LF353N	TI
IC 301	50.09.0107	RC4553NB	DUAL	RA, TI
IC 302	50.09.0101	72072ACP	DUAL BI-FET LF353N	TI
IC 401	50.09.0107	RC4553NB	DUAL	
IC 402	50.09.0107	RC4553NB	DUAL	RA, TI
IC 403	50.09.0101	72072ACP	DUAL BI-FET LF353N	TI
R 1	57.11.4339	3,3		
R 2	57.99.0209	5,62 PTC		P
R 3	57.99.0209	5,62 PTC		P
R 101	57.11.3562	5,6k	1%	
R 102	57.11.3562	5,6k	1%	
R 103	58.01.7103	10k	LIN 10% TRIM	AB, D
R 104	57.11.4561	560		
R 105	57.11.4103	10k		
R 106	57.11.4182	1,8k	2%	
R 107	57.11.3362	3,6k	2%	
R 108	57.11.4182	1,8k	2%	
R 109	57.11.4182	1,8k	2%	
R 110	57.11.6226	22M	10%	
R 111	57.11.4563	56k		
R 112	57.11.6226	22M	10%	
R 113	57.11.4103	10k		
R 114	57.11.4563	56k		

INDI	DATE	NAME		
④			RA - RAYTHEON	
③			TI - TEXAS INSTRUMENTS	
②			AB - ALLEN BRADLEY	
①			D - DIPLOMATICS	
○	20.8.86	ECKERT	P - PHILIPS	
STUDER			AUX. INDICATOR	1.913.130.81 PAGE 3 OF 6

INDI POS NO	PART NO	VALUE	SPECIFICATIONS/EQUIVALENT	MFR
R 311	57.11.4563	56k		
R 312	57.11.6226	22M		
R 313	57.11.4103	10k		
R 314	57.11.4563	56k		
R 315	57.11.4472	4,7k		
R 316	57.11.4822	8,2k		
R 401	57.11.3562	5,6k	1%	
R 402	57.11.3562	5,6k	1%	
R 403	58.01.7103	10k	LIN 10% TRIM	AB, D
R 404	57.11.4561	560		
R 405	57.11.4103	10k		
R 406	57.11.4182	1,8k	2%	
R 407	57.11.3362	3,6k	2%	
R 408	57.11.4182	1,8k	2%	
R 409	57.11.4182	1,8k	2%	
R 410	57.11.6226	22M		
R 411	57.11.4563	56k		
R 412	57.11.6226	22M		
R 413	57.11.4472	4,7k		
R 414	57.11.4563	56k		
R 415	57.11.4722	2,2k		
R 416	57.11.4822	8,2k		
R 501	57.11.3562	5,6k	1%	
R 502	57.11.3562	5,6k	1%	
R 503	58.01.7103	10k	LIN 10% TRIM	AB, D
R 504	57.11.4561	560		
R 505	57.11.4103	10k		
R 506	57.11.4182	1,8k	2%	

INDI	DATE	NAME		
④			AB - ALLEN BRADLEY	
③			D - DIPLOMATICS	
②				
①				
○	20.8.86	ECKERT		
STUDER			AUX. INDICATOR	1.913.130.81 PAGE 5 OF 6

INDI POS NO	PART NO	VALUE	SPECIFICATIONS/EQUIVALENT	MFR
R 115	57.11.4472	4,7k		
R 116	57.11.4822	8,2k		
R 201	57.11.3562	5,6k	1%	
R 202	57.11.3562	5,6k	1%	
R 203	58.01.7103	10k	LIN 10% TRIM	
R 204	57.11.4561	560		
R 205	57.11.4103	10k		
R 206	57.11.4182	1,8k	2%	
R 207	57.11.3362	3,6k	2%	
R 208	57.11.4182	1,8k	2%	
R 209	57.11.4182	1,8k	2%	
R 210	57.11.6226	22M		
R 211	57.11.4563	56k		
R 212	57.11.6226	22M		
R 213	57.11.4103	10k		
R 214	57.11.4563	56k		
R 215	57.11.4472	4,7k		
R 216	57.11.4822	8,2k		
R 301	57.11.3562	5,6k	1%	
R 302	57.11.3562	5,6k	1%	
R 303	58.01.7103	10k	LIN 10% TRIM	
R 304	57.11.4561	560		
R 305	57.11.4103	10k		
R 306	57.11.4182	1,8k	2%	
R 307	57.11.3362	3,6k	2%	
R 308	57.11.4182	1,8k	2%	
R 309	57.11.4182	1,8k	2%	
R 310	57.11.6226	22M		

INDI	DATE	NAME		
④				
③				
②				
①				
○	20.8.86	ECKERT		
STUDER			AUX. INDICATOR	1.913.130.81 PAGE 4 OF 6

INDI POS NO	PART NO	VALUE	SPECIFICATIONS/EQUIVALENT	MFR
R 507	57.11.3362	3,6k	2%	
R 508	57.11.4182	1,8k	2%	
R 509	57.11.4182	1,8k	2%	
T 101	1.022.218	1:1	LINE TRAFD	ST
T 201	1.022.218	1:1	LINE TRAFD	ST
T 301	1.022.218	1:1	LINE TRAFD	ST
T 401	1.022.218	1:1	LINE TRAFD	ST
T 501	1.022.218	1:1	LINE TRAFD	ST
X B	53.04.0118		LAMP HOLDER	
X I C	53.03.0166		IC HOLDER	
ME 101	1.913.001.04	120µA	INDICATOR	ST
ME 201	1.913.001.04	120µA	INDICATOR	ST
ME 301	1.913.001.04	120µA	INDICATOR	ST
ME 401	1.913.001.04	120µA	INDICATOR	ST
P 1	54.14.2012			

INDI	DATE	NAME		
④			ST - STUDER	
③				
②				
①				
○	20.8.86	ECKERT		
STUDER			AUX. INDICATOR	1.913.130.81 PAGE 6 OF 6

P 7

1.943.134

1.943.132

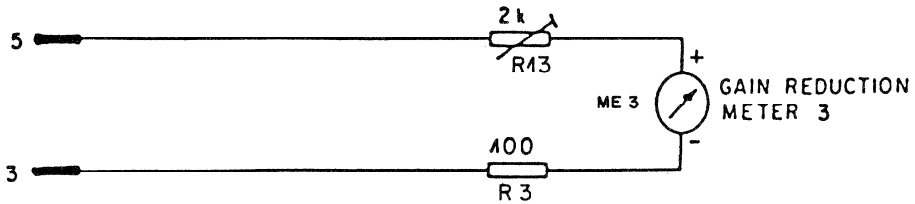
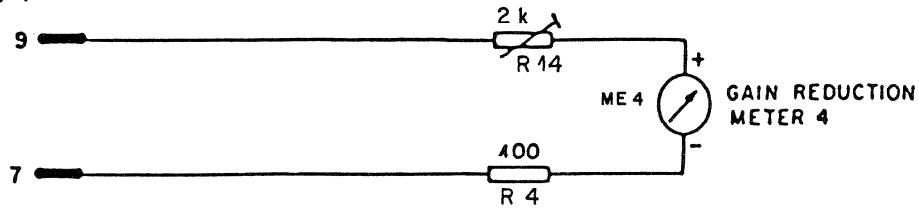

METER 2

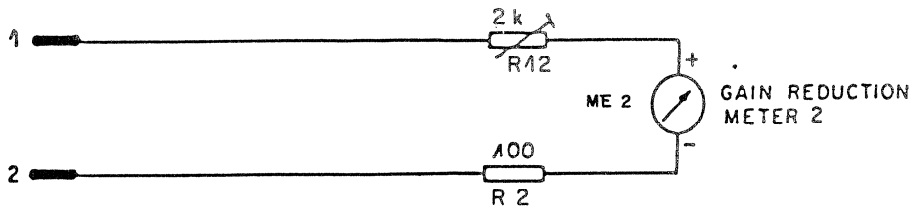

METER 4

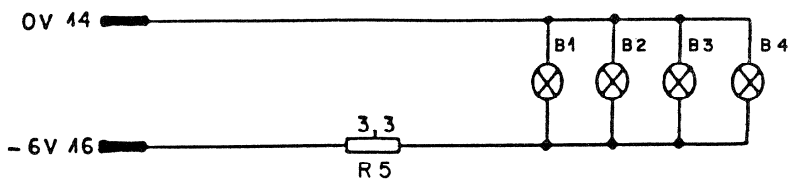
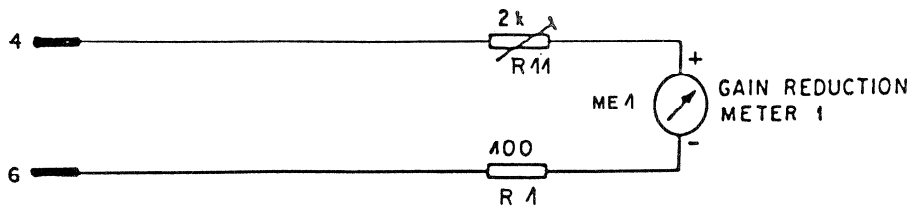

DATE:	28.9.84	9.10.84				PRINT NR. 1.943.130-11
SIGN:	<i>we</i>	<i>we</i>				
STUDER REGENSDORF ZÜRICH	2 GAIN REDUCTION-METER					SC 1.943.132
	4 GAIN REDUCTION-METER					SC 1.943.134

2 CHANNEL VERSION
4 CHANNEL VERSION

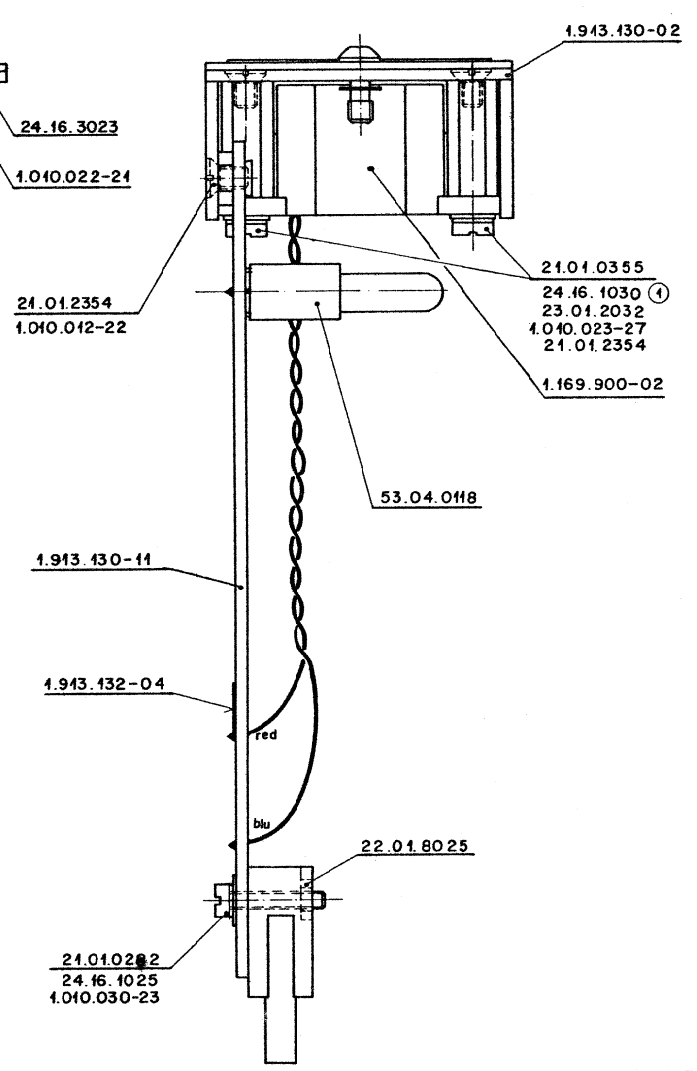
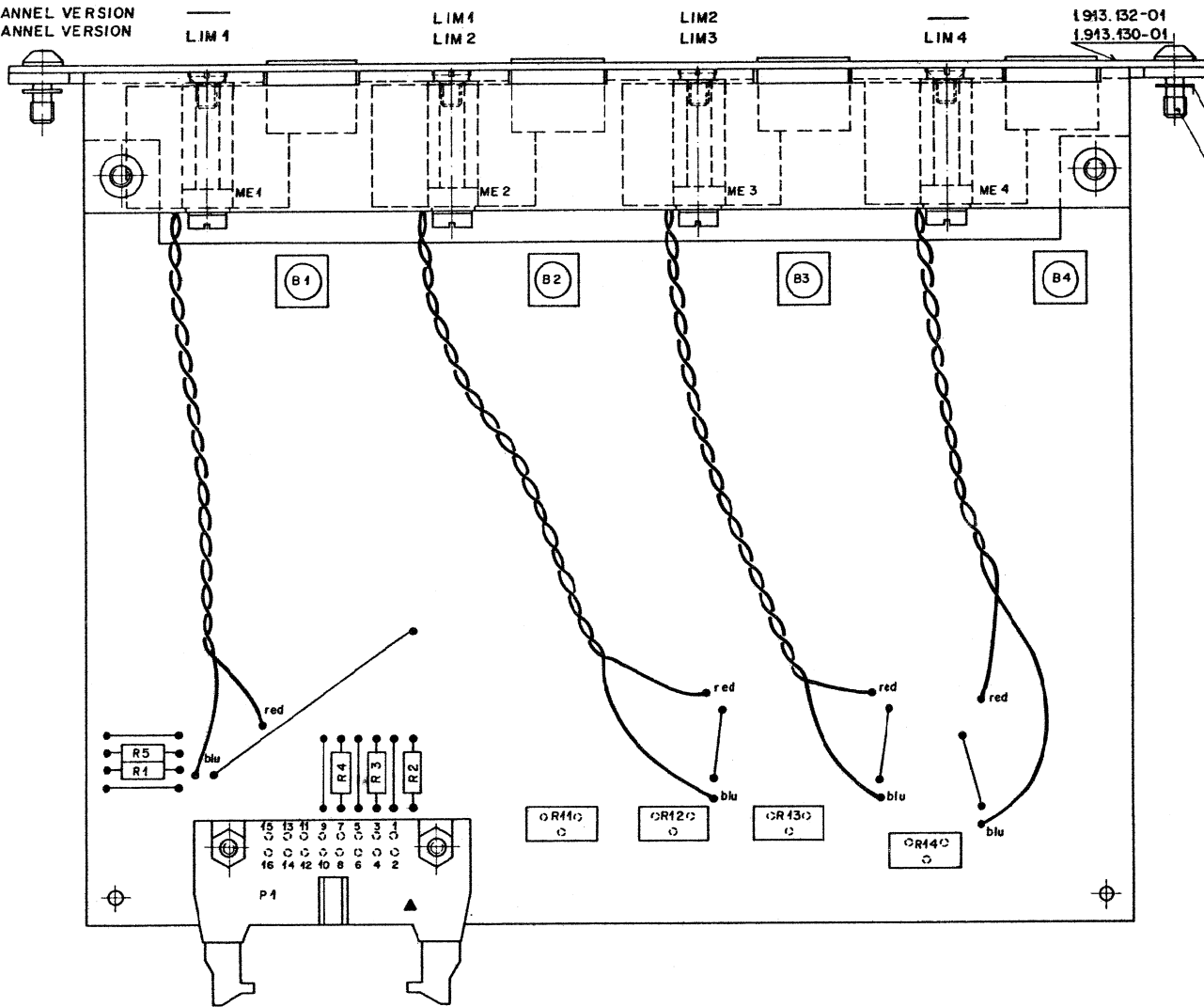

VALID FOR	NR. UNIT	PARTS
2 CHANNEL VERSION	1.913.132-00	R2,R3,R5,R12,R13/ME2,ME3/B2, B3
4 CHANNEL VERSION	1.913.134-00	R 1- R 5, R11-R14/ME1- ME4/B1- B4

Werkstoff:	Norm-Nr.:	Güte:	Änderung:	③
	DIN-Bez.:	Oberflächliche:		②
	Abmessung:	Beh.:	1.6.85 A Ho	①
Zugehörige Unterlagen:	Freimasstoleranz:	Maßstab:	2.40.84	④
PL	±	2:1	STJ	Gez. Gepr. Ges. Index
Ersatz für:	Ersetzt durch:	Kopie für:		
STUDER REGENSDORF ZÜRICH		Benennung: LIMITER INDICATOR		Nummer: 1.913.134-00

IND	POS NO	PART NO	VALUE	SPECIFICATIONS/EQUIVALENT	MFR
	B1+4	51.02.0144	6V	30mA	0
	R1	57.M.4101	100		
	R2	57.M.4101	100		
	R3	57.M.4101	100		
	R4	57.M.4101	100		
	R5	57.M.4339	33		
	RA1	58.01.7202	2k	LIN 10% TRIM	AB,D
	RA2	58.01.7102	2k	LIN 10% TRIM	AB,D
	RA3	58.01.7202	2k	LIN 10% TRIM	AB,D
	RA4	58.01.7202	2k	LIN 10% TRIM	AB,D
①	ME1	A.169.900.02	120 μ A	INDICATOR	ST
①	ME2	A.169.900.02	120 μ A	INDICATOR	ST
①	ME3	A.169.900.02	120 μ A	INDICATOR	ST
①	ME4	A.169.900.02	120 μ A	INDICATOR	ST
	PA	54.14.2013			
	XB	53.04.0118		LAMP HOLDER W2 x 4.60	

IND	DATE	NAME		
④			0 - OSRAM	
③			ST - STUDER	
②			AB - ALLEN BRADLEY	
①	24.4.89	Wc	D - DIPLOMATICS	
○	10.12.84	WVC		
STUDER		LIMITER INDICATOR	A.913.134.00	PAGE 1 OF 1

Signalization Indication Unit 1.913.140 / 41

SIGN / INDICATION UNIT

Zentrale Bedienungs- und Anzeigeeinheit für die Studio Signalisation, für PFL und Mix-down, Warnsignale für Overload und On Air.

MIXDOWN-Taste zum Umschalten aller Eingangseinheiten auf Tape (nur bei Mehrkanalversion /1.913.141)

PFL Rückstelltaste für alle PFL- und P.Solo-Tasten. LED leuchtet sobald eine oder mehrere PFL / P.Solo Tasten gedrückt sind.

OVERLOAD zeigt die Uebersteuerung eines oder mehrerer Eingänge an.

ON AIR Rückmeldelampe des Zustandes der Sendeleitung im Schaltraum.

STUDIOSIGNALISATION

CALL Impulstaste für gelbes Licht im Studio, gelbe LED zur Rückmeldung.

READY Haltende-Taste für grünes Vorbereitungssignal mit Zustandsanzeige am LED.

ON Haltende-Taste für rotes Studio-Warnsignal. Das Signal wird durchgeschaltet sobald wenigstens bei einer Eingangseinheit der Mikrofonkanal durchgeschaltet ist.

Bemerkung:

Die Zusammenhänge der

PFL - Funktion
Mix-Down - Funktion
Sign - Funktion

werden in anderen Beschreibungen aufgezeigt.

TECHNISCHE DATEN

Speisespannungen:	+ 15 V	5 mA
	- 15 V	5 mA
	- 6 V	variabel
	- 24 V	variabel

MECHANISCHE DATEN

Frontplatte dunkelgrau gespritzt	
Abmessungen Frontplatte	170 x 40 mm
Tiefe	135 mm
Gewicht	170 gr

SIGN / INDICATION UNIT

Central operating and indication unit for the studio signalling, for PFL and mix down, warning signals for overload and on air.

MIXDOWN button for changing over all input units to tape (only for multichannel version 1.913.141).

PFL reset button for all PFL and P. SOLO buttons. LED turns on as soon as one or more PFL / P. SOLO buttons have been pressed.

OVERLOAD indicates that an overload condition on one or several inputs have been detected.

The ON AIR pilot lamp signals the status of the on air line in the master control room.

STUDIO SIGNALLING

CALL, momentary-action push button for yellow light in the studio, yellow status LED.

READY, self-locking push button for green preparation signal with status LED.

ON, self-locking push button for red studio warning signal. The signal is connected through as soon as the microphone channel of at least one input unit and one master channel has been connected through.

NOTE

The interaction between

PFL function
Mix down function
Sign function

is described elsewhere.

Specifications

Supply voltages	+15 V	5 mA
	-15 V	5 mA
	- 6 V	variable
	-24 V	variable

PHYSICAL DATA

Front panel laquered dark grey	
Dimensions of front panel	170 x 40 mm
Depth	135 mm
Weight	170 g

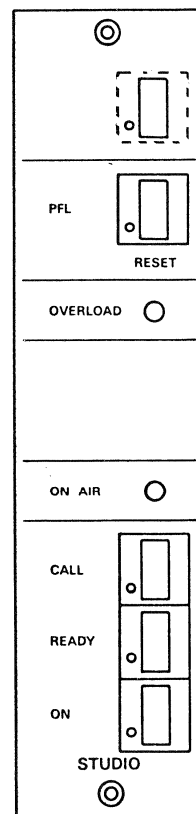

Block Diagram 1.913.140 / 141

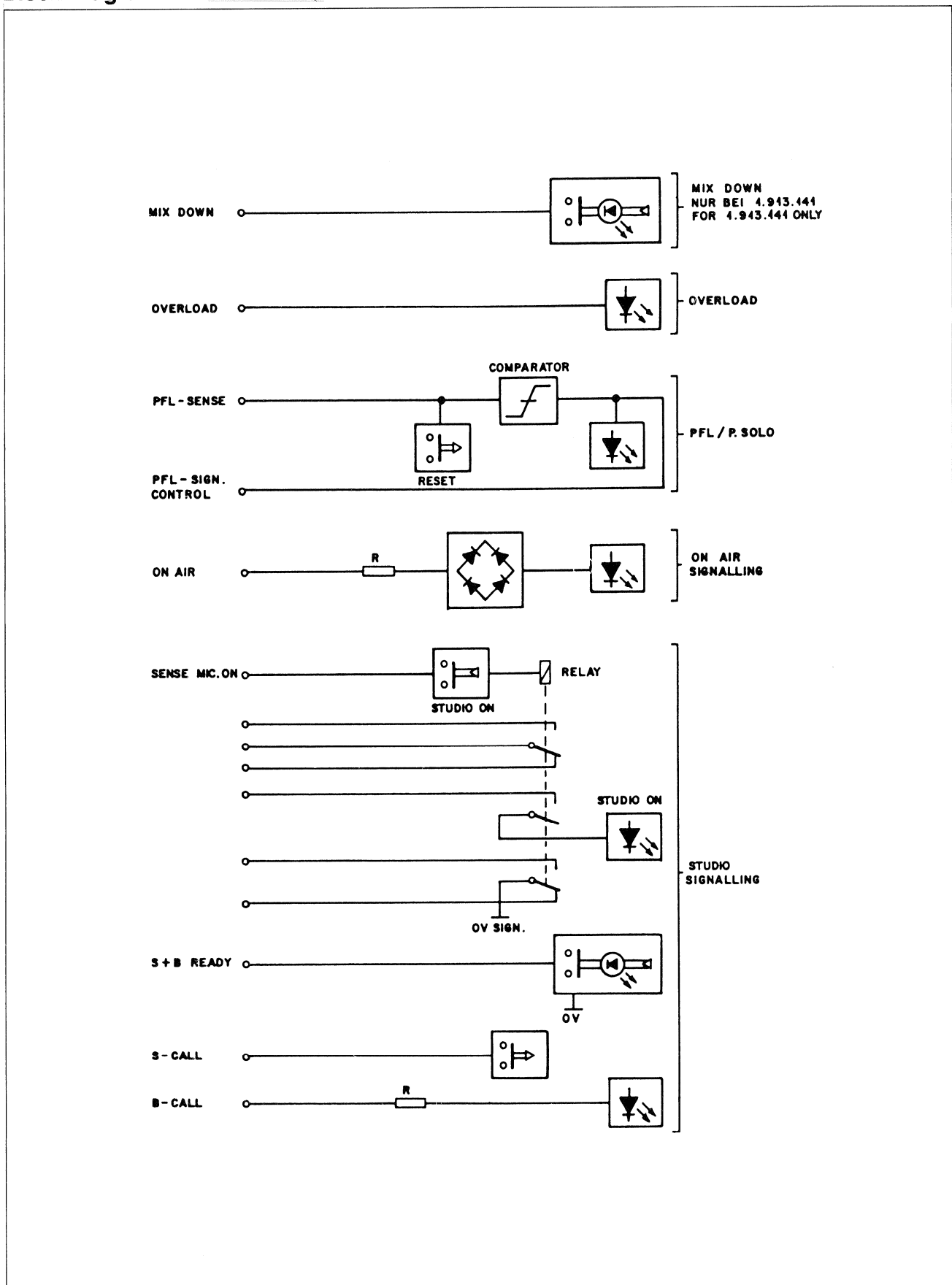

Signalization / Indication Unit 1.913.140.81

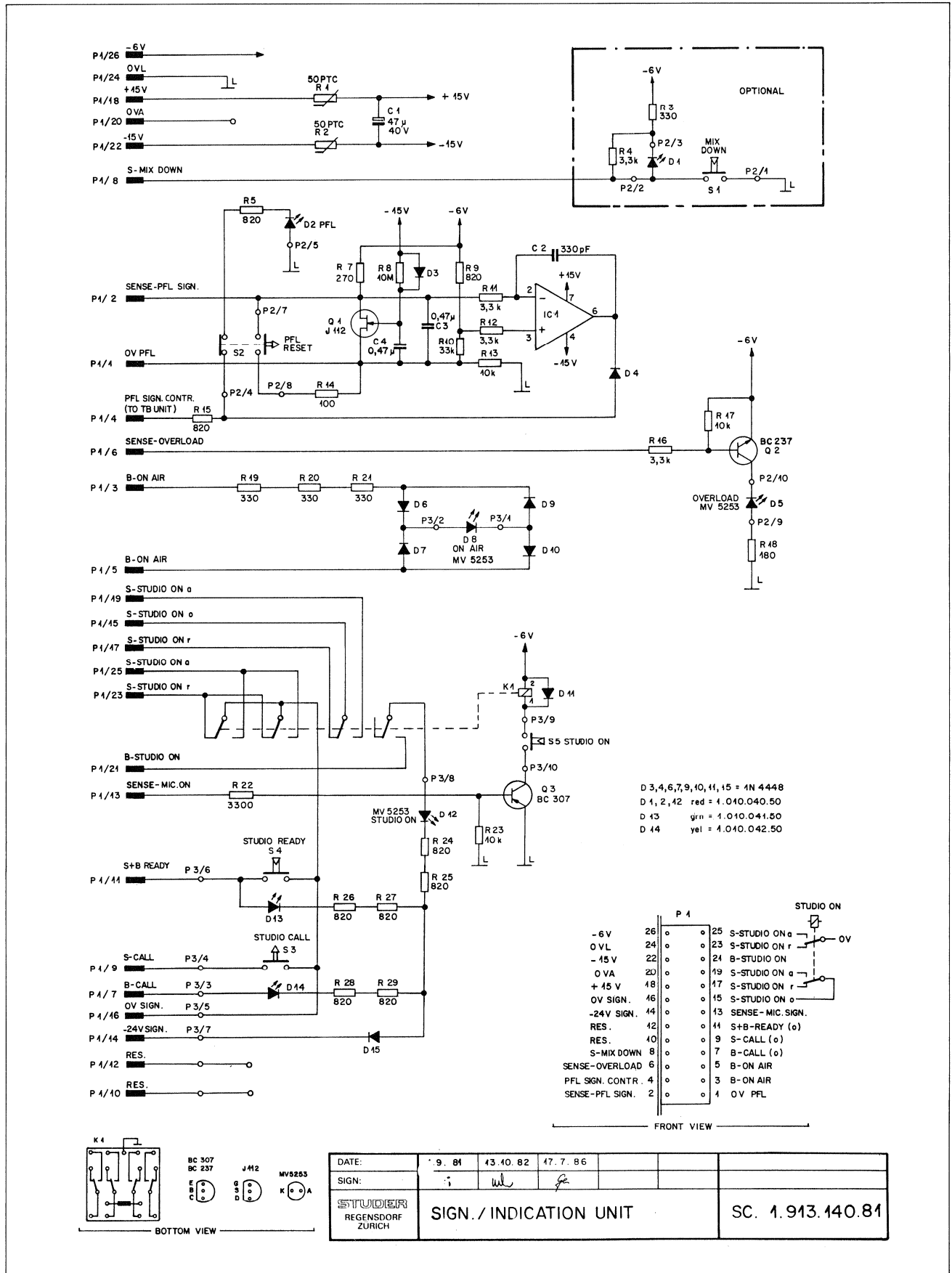

DATE:	9. 81	43.10.82	17.7.86		
SIGN:					
STUDER REGENSDORF ZURICH	SIGN./ INDICATION UNIT				SC. 1.913.140.81

Signalization Indication Unit 1.913.140

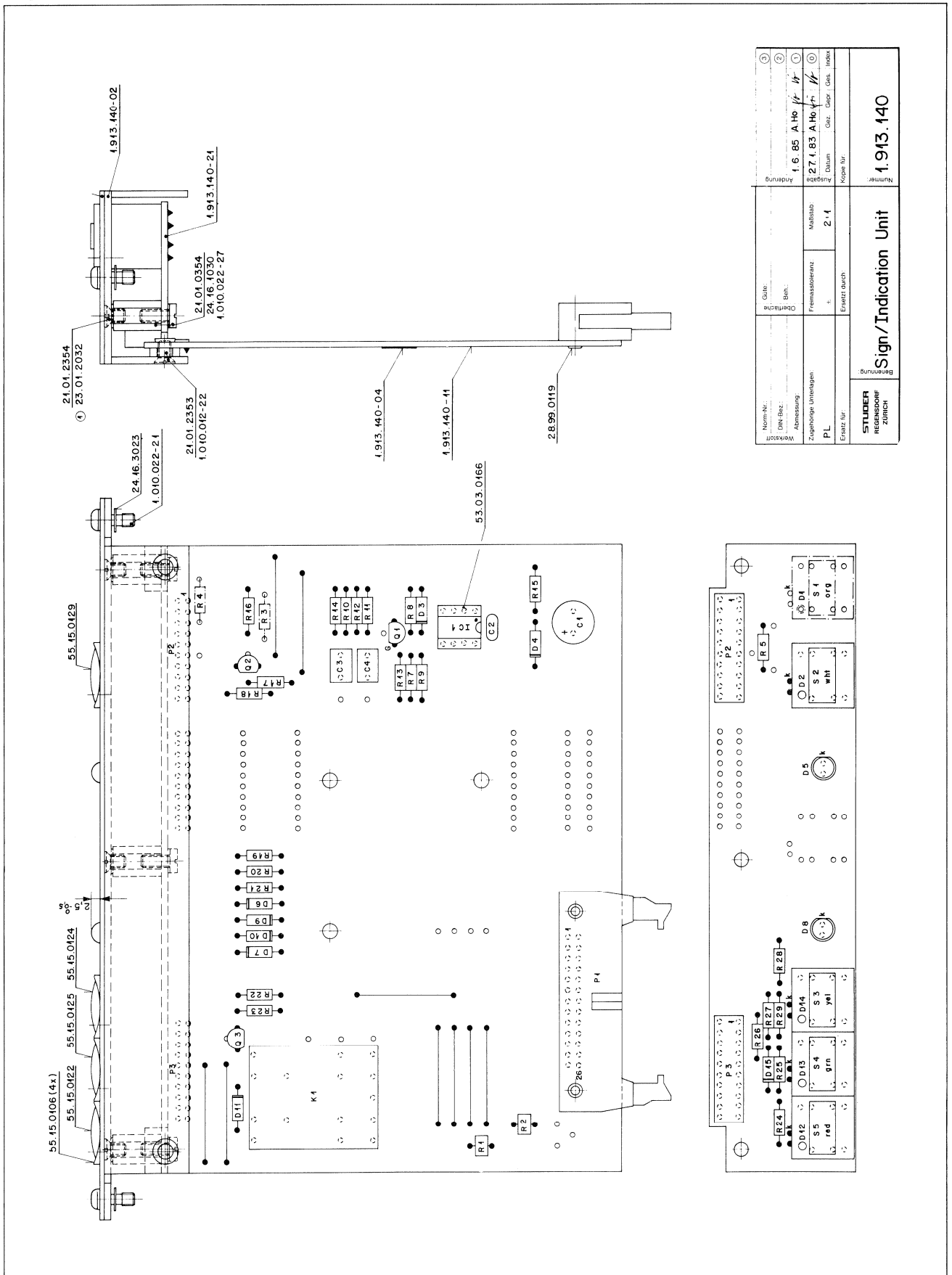

Norm-Nr.	Geib.	1.6.85	A.Ho	hr
DN-Bez.	Defläche	27.1.83	A.Ho	hr
Abmessung	Prüfmasse/nr.	Datum	Gez.	Ges.
Zugehörige Unterlagen	1.	2.1	Index	
Erstellt für	Erstellt durch			
STUDER REGENSCHNITT ZÜRICH		1.913.140		

Signalization / Indication Unit 1.913.140.81

INDI POS NO	PART NO	VALUE	SPECIFICATIONS/EQUIVALENT	MFR
C 1	59.22.6430	47µF	40 V ELECTRN.	
C 2	59.34.4331	330pF	CERAMIC	
C 3	59.06.0474	0,47µF	POLYSTYRENE	
C 4	59.06.0474	0,47µF	POLYSTYRENE	
D 1	50.04.2121	CQY41N	LED RED (MIX DOWN)	T
D 2	50.04.2121	CQY41N	LED RED	T
D 3	50.04.0125	M4448		
D 4	50.04.0125	M4448		
D 5	50.04.2111	MV5753	LED RED	MS
D 6	50.04.0125	M4448		
D 7	50.04.0125	M4448		
D 8	50.04.2111	MV5753	LED RED	MS
D 9	50.04.0125	M4448		
D 10	50.04.0125	M4448		
D 11	50.04.0125	M4448		
D 12	50.04.2121	CQY41N	LED RED	T
D 13	50.04.2132	CQY78N	LED GRN	T
D 14	50.04.2133	CQY75N	LED YEL	T
D 15	50.04.0125	M4448		
IC 1	50.09.0103	TL071CP	LF351	TI
K 1	56.04.0146	4U	RELAY	SA
Q 1	50.03.0350	J 112	FET	SX
Q 2	50.03.0436	BC 237B	NPN	BC 650 B IS, P
Q 3	50.03.0515	BC 207B	PNP	BC 560 B IS, P

INDI	DATE	NAME	
④		SA - SAUER SDS	I - ITT
③		T - TELEFUNKEN	S - SIE HENS
②		MS - MORGANTON	P - PHILIPS
①		TI - TEXAS INSTR.	
○	17.7.86	ECKERT	SX - SLLI CON 11

STUDER SIGN/INDICATION UNIT 1.913.140.81 PAGE 1 OF 3

INDI POS NO	PART NO	VALUE	SPECIFICATIONS/EQUIVALENT	MFR
S 1	55.15.0113	LATCHING	MODULAR SWITCH (MIX DOWN)	U
S 2	55.15.0112	MOMENTARY	MODULAR SWITCH	U
S 3	55.15.0112	MOMENTARY	MODULAR SWITCH	U
S 4	55.15.0113	LATCHING	MODULAR SWITCH	U
S 5	55.15.0113	LATCHING	MODULAR SWITCH	U

INDI	DATE	NAME	
④			U - UNIMEC
③			
②			
①			
○	17.7.86	ECKERT	

STUDER SIGN/INDICATION UNIT 1.913.140.81 PAGE 2 OF 3

INDI POS NO	PART NO	VALUE	SPECIFICATIONS/EQUIVALENT	MFR
R 1	57.99.0206	50	PTC	P
R 2	57.99.0206	50	PTC	P
R 3	57.11.4331	330	(MIX DOWN)	
R 4	57.11.4332	3,3k	(MIX DOWN)	
R 5	57.11.4821	820		
R 6				
R 7	57.11.4271	270 Ω		
R 8	57.11.4106	10M		
R 9	57.11.4821	820		
R 10	57.11.4333	33k		
R 11	57.11.4332	3,3k		
R 12	57.11.4332	3,3k		
R 13	57.11.4103	10k		
R 14	57.11.4101	100		
R 15	57.11.4821	820		
R 16	57.11.4332	33k		
R 17	57.11.4103	10k		
R 18	57.11.4181	180		
R 19	57.11.4331	330		
R 20	57.11.4331	330		
R 21	57.11.4331	330		
R 22	57.11.4332	3,3k		
R 23	57.11.4103	10k		
R 24	57.11.4821	820		
R 26	57.11.4821	820		
R 26	57.11.4821	820		
R 27	57.11.4821	820		
R 28	57.11.4821	820		
R 29	57.11.4821	820		

INDI	DATE	NAME	
④			P - PHILIPS
③			
②			
①			
○	17.7.86	ECKERT	

STUDER SIGN/INDICATION UNIT 1.913.140.81 PAGE 2 OF 3

Audio Generator 1.913.150

Test Generator 1.913.150

Klirrarmer NF-Oszillator mit stabilisierter Ausgangsspannung.
 Neun Frequenzen.
 Weisses- und rosa Rauschen.
 Identifikationston (Frequenz 1900 Hz oder nach Kundenwunsch).
 Leitungsverstärker mit zwei verschiedenen Ausgangspegeln.

AUDIO GENERATOR 1.913.150

Low-distortion AF generator with stabilized output voltage.
 Nine frequencies
 White and pink noise.
 Identification tone (frequency 1900 Hz or as specified by customer)
 Line amplifier with two different output levels.

Blockschaltbild

BLOCK DIAGRAM

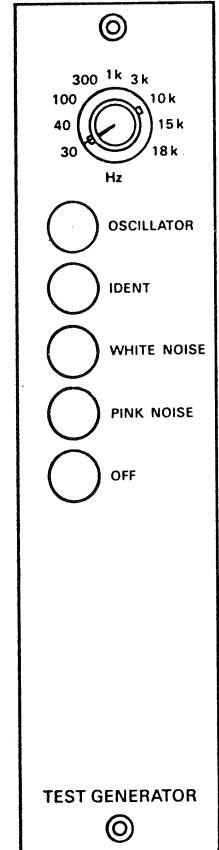
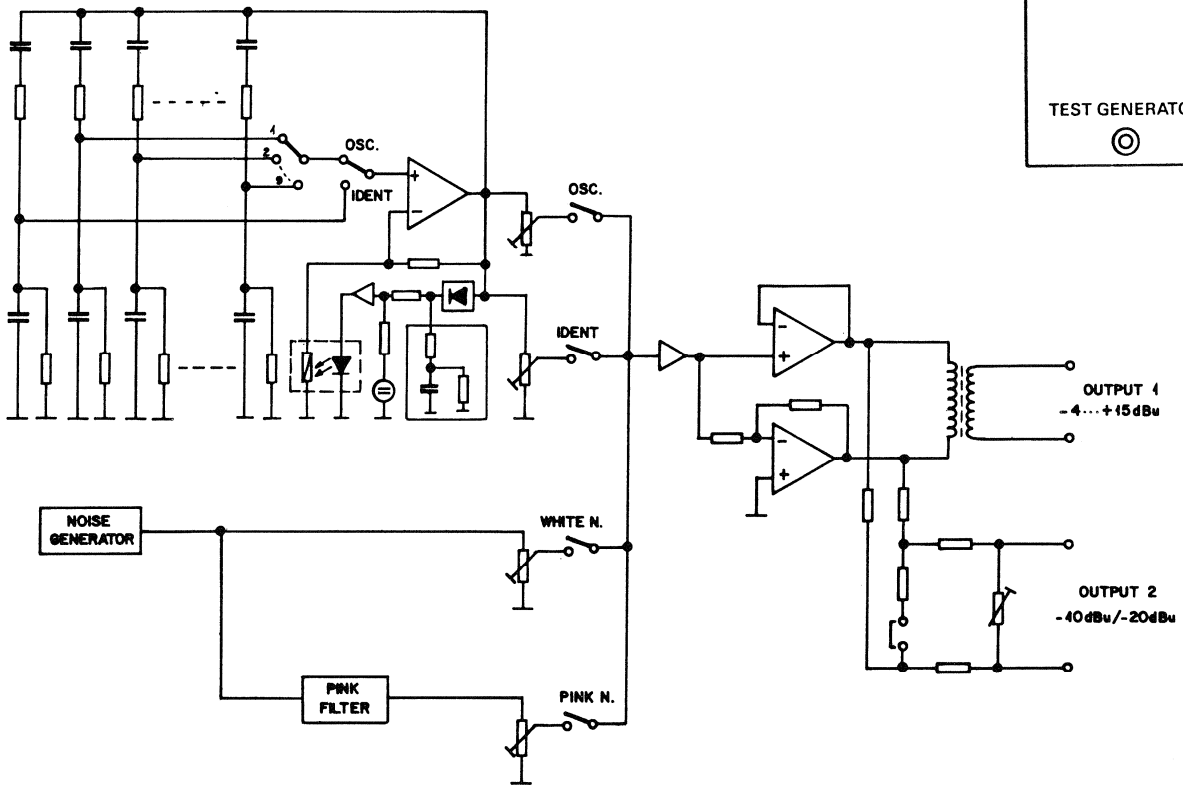

Audio Generator 1.913.150

Technische DatenAusgangsfrequenzen

Neun Festfrequenzen mit Drehschalter wählbar.

Identifikationston

Einschwingzeit 30 Hz
1 kHz

Ausgang 1

symmetrisch, erdfrei
Ausgangspegel mit Trimpotentiometer einstellbar

Ausgangsimpedanz

Lastwiderstand

Frequenzgang

Klirrfaktor 30 Hz...18 kHz
100 Hz...10 kHz

Ausgang 2

symmetrisch
Ausgangspegel einstellbar

Ausgangsimpedanz

Weisses Rauschen

Frequenzgang 20 Hz . 20 kHz

Rosa Rauschen

Frequenzgang

Auf Wunsch

schaltbarer Abschwächer

Stromversorgung

Betriebsspannung

Stromverbrauch

Abmessungen

Frontplatte

Tiefe über alles

Gewicht

SPECIFICATIONSOutput frequencies

Nine fixed frequencies, selectable with rotary switch

30 Hz)
40 Hz)
100 Hz)
300 Hz)
1 kHz)
3 kHz) $\pm 5\%$
10 kHz)
15 kHz)
18 kHz)

Identification frequency

1,9 kHz $\pm 10\%$

Settling time 1 kHz 30 Hz

~ 4 sec
 ~ 1 sec

Output 1

Balanced and floating
Output level variable with trimmer potentiometer

-4 dBu...+15dBu

Output impedance

< 40 Ohm

Load impedance

≥ 200 Ohm

Frequency response

$\pm 0,2$ dB

Harmonic distortion 30 Hz ... 18 kHz
100 Hz ... 10 kHz

$< 0,1\%$
 $< 0,05\%$

Output 2

Balanced
Output level adjustable

-10dBu/-20dBu

Output impedance

~ 1 kOhm

White noise

Frequency response 20 Hz ... 20 kHz

digital noise source
with pseudo-random
sequence generator
 ± 1 dB

Pink noise

Frequency response

4 stage cascade filter
-3dB / octave
 ± 1 dB

Switchable attenuator available on request

0/-10/-20 dB

Supply

Operating voltage

± 15 V

Connected load

30 mA

Physical data

Front panel sprayed charcoal grey
Dimensions of front panel

170 x 40,4 mm

Over all depth

135 mm

Weight

approx. 250 gr

Audio Generator 1.913.150

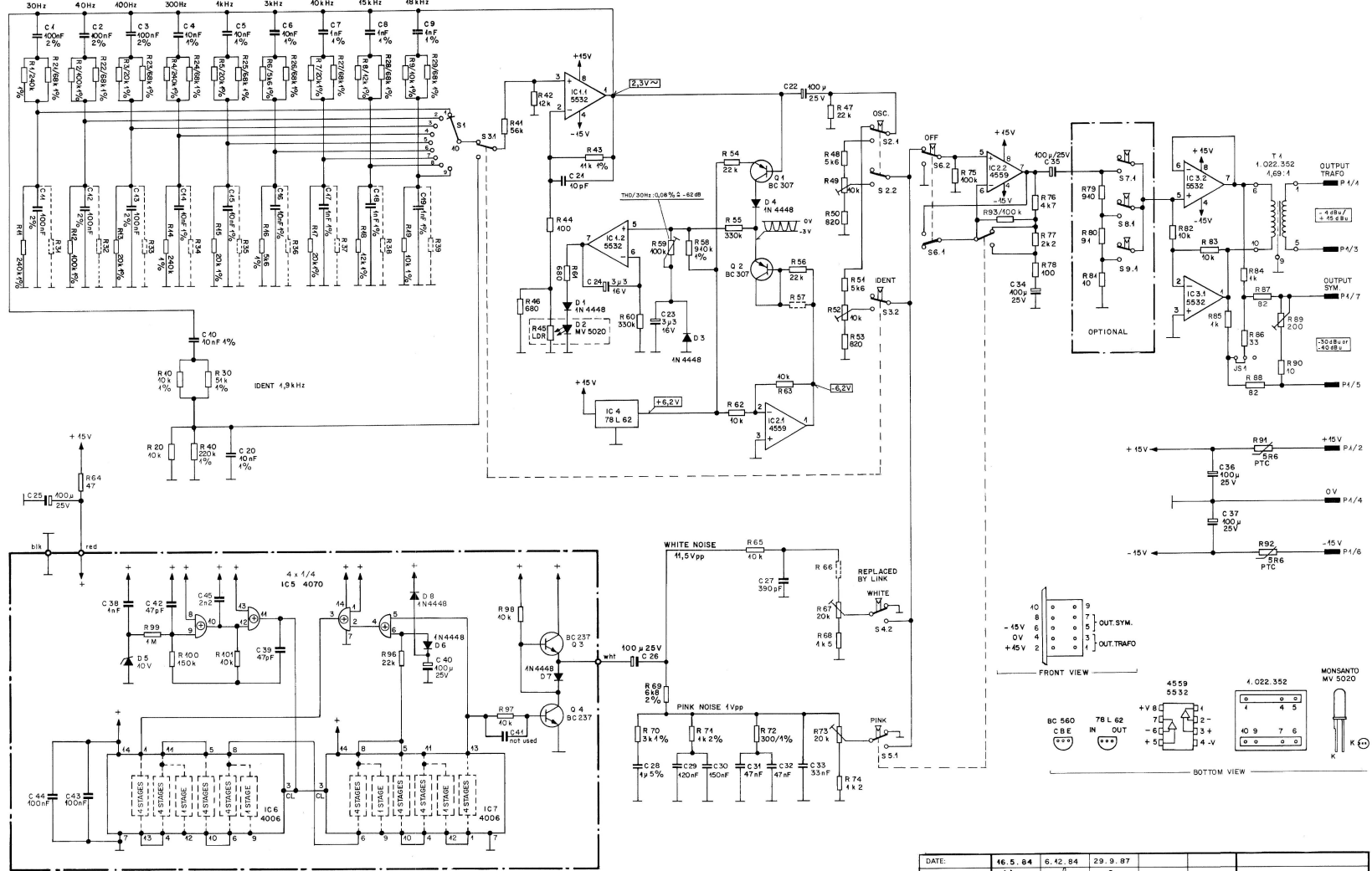

DATE:	16.5.84	6.42.84	29.9.87	
SIGN:	We	ul	se	
STUDER REGENDORF ZÜRICH	GENERATOR			SC 1.913.150.81

Audio Generator 1.913.150

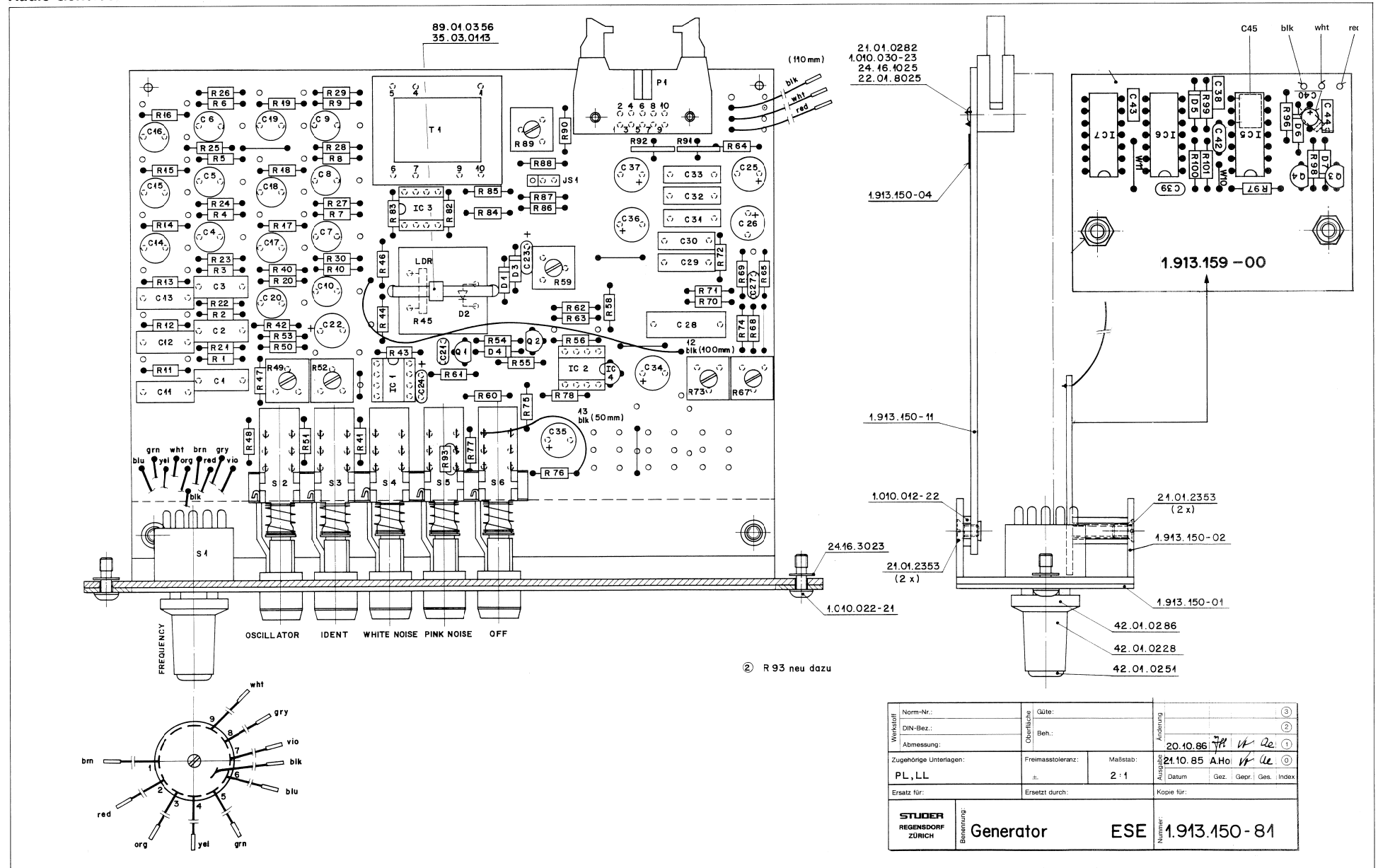

② R 93 neu dazu

Werkstoff:	Norm-Nr.:	Oberfläche:	Güte:	Änderung:	③
	DIN-Bez.:		Beh.:		②
Zugehörige Unterlagen:	Abmessung:	Freimasstoleranz:	Maßstab:	Ausgabe:	20.10.86 <i>PL</i> <i>LL</i> <i>Re</i> ①
	PL, LL				±
Ersatz für:	Ersetzt durch:	Datum:		Gez.:	Gepr.:
Bemerkung:		Generator		ESE	
Bemerkung:		Generator		Nummer: 1.913.150-84	

Audio Generator 1.913.150

IND.	POS.NO.	PART NO.	VALUE	SPECIFICATIONS / EQUIVALENT	MANUF.	IND.	POS.NO.	PART NO.	VALUE	SPECIFICATIONS / EQUIVALENT	MANUF.
C.....1	59.99.0234	100 nF	2%	PE		R....56	57.11.4223	22 kOhm	5%	0.25W MF	
C.....2	59.99.0234	100 nF	2%	PE		R....57		not used			
C.....3	59.99.0234	100 nF	2%	PE		R....58	57.11.3914	910 kOhm	1%	0.25W MF	
C.....4	59.05.1103	10 nF	2%	PE		R....59	58.01.8104	100 kOhm	10%	0.50W	trimming resistor
C.....5	59.05.1103	10 nF	2%	PE		R....60	57.11.4334	330 kOhm	5%	0.25W MF	
C.....6	59.05.1103	10 nF	2%	PE		R....61	57.11.4681	680 Ohm	5%	0.25W MF	
C.....7	59.05.1102	1 nF	2%	PE		R....62	57.11.4103	10 kOhm	5%	0.25W MF	
C.....8	59.05.1102	1 nF	2%	PE		R....63	57.11.4103	10 kOhm	5%	0.25W MF	
C.....9	59.05.1102	1 nF	2%	PE		R....64	57.11.4470	47 Ohm	5%	0.25W MF	
C.....10	59.05.1103	10 nF	2%	PE		R....65	57.11.4103	10 kOhm	5%	0.25W MF	
C.....11	59.99.0234	100 nF	2%	PE		R....66		1nK			
C.....12	59.99.0234	100 nF	2%	PE		R....67	58.01.8203	20 kOhm	10%	0.50W	trimming resistor
C.....13	59.99.0234	100 nF	2%	PE		R....68	57.11.4152	1.5 kOhm	5%	0.25W MF	
C.....14	59.05.1103	10 nF	2%	PE		R....69	57.11.4682	6.8 kOhm	2%	0.25W MF	
C.....15	59.05.1103	10 nF	2%	PE		R....70	57.11.3902	3 kOhm	1%	0.25W MF	
C.....16	59.05.1103	10 nF	2%	PE		R....71	57.11.4102	1 kOhm	2%	0.25W MF	
C.....17	59.05.1102	1 nF	2%	PE		R....72	57.11.3301	300 Ohm	2%	0.25W MF	
C.....18	59.05.1102	1 nF	2%	PE		R....73	58.01.8203	20 kOhm	10%	0.50W	trimming resistor
C.....19	59.05.1102	1 nF	2%	PE		R....74	57.11.4122	1.2 kOhm	5%	0.25W MF	
C.....20	59.05.1103	10 nF	2%	PE		R....75	57.11.4104	100 kOhm	5%	0.25W MF	
C.....21	59.34.1100	10 pF	5%	CE		R....76	57.11.4472	4.7 kOhm	2%	0.25W MF	
C.....22	59.22.5101	100 uF	-20%	16V EL		R....77	57.11.4222	2.2 kOhm	2%	0.25W MF	
C.....23	59.26.2399	3.3 uF	-20%	16V SAL		R....78	57.11.4101	100 Ohm	2%	0.25W MF	
C.....24	59.26.2399	3.3 uF	-20%	16V SAL		R....79		3.3 Ohm	1%	57113911 option	
C.....25	59.22.5101	100 uF	-20%	16V EL		R....80		91 Ohm	1%	57113100 option	
C.....26	59.22.5101	100 uF	-20%	16V EL		R....81		10 Ohm	1%		
C.....27	59.34.1101	390 pF		CE		R....82	57.11.4103	10 kOhm	5%	0.25W MF	
C.....28	59.02.0125	1 uF	5%	PC		R....83	57.11.4103	10 kOhm	5%	0.25W MF	
C.....29	59.02.0124	120 nF	5%	PC		R....84	57.11.4102	1 kOhm	2%	0.25W MF	
C.....30	59.02.0124	150 nF	5%	PC		R....85	57.11.4102	1 kOhm	2%	0.25W MF	
C.....31	59.02.0473	47 nF	5%	PC		R....86	57.11.4330	33 Ohm	2%	0.25W MF	
C.....32	59.02.0473	47 nF	5%	PC		R....87	57.11.4820	82 Ohm	2%	0.25W MF	
C.....33	59.02.0473	33 nF	5%	PC		R....88	57.11.4820	82 Ohm	2%	0.25W MF	
C.....34	59.22.5101	100 uF	-20%	16V EL		R....89	58.01.8201	200 Ohm	10%	0.50W	trimming resistor
C.....35	59.22.5101	100 uF	-20%	16V EL		R....90	57.11.4100	10 Ohm	5%	0.25W MF	
C.....36	59.22.5101	100 uF	-20%	16V EL		R....91	57.99.0209	5.6 Ohm		PTC	Philips Nr.2322 662 91005
C.....37	59.22.5101	100 uF	-20%	16V EL		R....92	57.99.0209	5.6 Ohm		PTC	Philips Nr.2322 662 91005
D.....1	50.04.0125	IN4448		any		R....93	57.11.4104	100 kOhm	5%	0.25W MF	
D.....2	50.04.2104	MV3020	red	GI.Lix		S.....1	55.13.0025	1#9		rotary-switch	St
D.....3	50.04.0125	IN4448		any		S.....2	55.15.0005	2#U		2u gold	
D.....4	50.04.0125	IN4448		any		S.....3		2#U		see S 2	
IC.....1	50.09.0105	NE5532 N	dual	op. amp.	Ti+Sig,Ra	S.....4		2#U		see S 2	
IC.....2	50.09.0107	RC4558 N	dual	op. amp.	Ti+Sig,Ra	S.....5		2#U		see S 2	
IC.....3	50.09.0105	NE5532 N	dual	op. amp.	Ti+Sig,Ra	S.....6		2#U		see S 2	
IC.....4	50.10.0101	78L62	6.2V		Fc	S.....7		2#U		2u gold option	
P.....7	54.14.2011	10 pin			Yamahaichi	S.....8		2#U		see S 7 option	
Q.....1	50.03.0496	8C 560	PNP	IC>100mA, B>100	any	S.....9		2#U		see S 7 option	
Q.....2	50.03.0496	8C 560	PNP	IC>100mA, B>100	any	T.....1	1.022.352.00			output trafo 1.69:1	St
R.....1	57.11.3244	240 kOhm	1%	0.25W MF		(10) C....38	59.06.5102	1 nF	10%	PE	
R.....2	57.11.3104	100 kOhm	1%	0.25W MF		(10) C....39	59.34.2470	47 pF	5%	CE	
R.....3	57.11.3203	20 kOhm	1%	0.25W MF		(10) C....40	59.26.9109	22 uF	-20%	SAL	
R.....4	57.11.3244	240 kOhm	1%	0.25W MF		(10) C....41		not used			
R.....5	57.11.3203	20 kOhm	1%	0.25W MF		(10) C....42	59.34.2470	47 pF	5%	CE	
R.....6	57.11.3562	5.6 kOhm	1%	0.25W MF		(10) C....43	59.06.5104	100 nF	20%	PE	
R.....7	57.11.3203	20 kOhm	1%	0.25W MF		(10) C....44	59.06.5104	100 nF	20%	PE	
R.....8	57.11.3123	12 kOhm	1%	0.25W MF		(10) D.....5	50.04.1108	2.5kV		400mW	
R.....9	57.11.3103	10 kOhm	1%	0.25W MF		(10) D.....6	50.04.0125	IN4448			any
R.....10	57.11.3103	10 kOhm	1%	0.25W MF		(10) D.....7	50.04.0125	IN4448			any
R.....11	57.11.3244	240 kOhm	1%	0.25W MF		(10) IC....5	50.07.0070	CD4070		2-input EXOR	Fc,MoT
R.....12	57.11.3104	100 kOhm	1%	0.25W MF		(10) IC....6	50.07.1006	CD4006		18 bit SHIFT-REGISTER	Fc,MoT
R.....13	57.11.3203	20 kOhm	1%	0.25W MF		(10) IC....7	50.07.1006	CD4006		18 bit SHIFT-REGISTER	Fc,MoT
R.....14	57.11.3244	240 kOhm	1%	0.25W MF		(10) Q.....3	50.03.0436	8C 237		NPN IC>100mA, B>100	any
R.....15	57.11.3203	20 kOhm	1%	0.25W MF		(10) Q.....4	50.03.0436	8C 237		NPN IC>100mA, B>100	any
R.....16	57.11.3562	5.6 kOhm	1%	0.25W MF		(10) R....94		not exist			
R.....17	57.11.3203	20 kOhm	1%	0.25W MF		(10) R....95		not exist			
R.....18	57.11.3123	12 kOhm	1%	0.25W MF		(10) R....96	57.11.4223	22 kOhm	2%	0.25W MF	
R.....19	57.11.3103	10 kOhm	1%	0.25W MF		(10) R....97	57.11.4103	10 kOhm	2%	0.25W MF	
R.....20	57.11.3103	10 kOhm	1%	0.25W MF		(10) R....98	57.11.4103	10 kOhm	2%	0.25W MF	
R.....21	57.11.3683	68 kOhm	1%	0.25W MF		(10) R....99	57.11.4105	1 kOhm	5%	0.25W MF	
R.....22	57.11.3683	68 kOhm	1%	0.25W MF		(10) R....100	57.11.4194	150 kOhm	2%	0.25W MF	
R.....23	57.11.3683	68 kOhm	1%	0.25W MF		(10) R....101	57.11.4103	10 kOhm	2%	0.25W MF	
R.....24	57.11.3683	68 kOhm	1%	0.25W MF							
R.....25	57.11.3683	68 kOhm	1%	0.25W MF							
R.....26	57.11.3683	68 kOhm	1%	0.25W MF							
R.....27	57.11.3683	68 kOhm	1%	0.25W MF							
R.....28	57.11.3683	68 kOhm	1%	0.25W MF							
R.....29	57.11.3683	68 kOhm	1%	0.25W MF							
R.....30	57.11.3513	51 kOhm	1%	0.25W MF							
R.....31		not used		1%	0.25W MF						
R.....32		not used		1%	0.25W MF						
R.....33		not used		1%	0.25W MF						
R.....34		not used		1%	0.25W MF						
R.....35		not used		1%	0.25W MF						
R.....36		not used		1%	0.25W MF						
R.....37		not used		1%	0.25W MF						
R.....38		not used		1%	0.25W MF						
R.....39		not used		1%	0.25W MF						
R....40	57.11.4224	220 kOhm	5%	0.25W MF							
R....41	57.11.4563	56 kOhm	5%	0.25W MF							
R....42	57.11.3123	12 kOhm	1%	0.25W MF							
R....43	57.11.3113	11 kOhm	2%	0.25W MF							
R....44	57.11.4101	100 Ohm	5%	0.25W MF							
R....45	57.99.0136	1 kOhm		LDR							
R....46	57.11.4661	680 Ohm	5%	0.25W MF	heimann						
R....47	57.11.4223	22 kOhm	5%	0.25W MF							
R....48	57.11.4662	5.6 kOhm	5%	0.25W MF							
R....49	58.01.8103	10 kOhm	10%	0.50W	trimming resistor						
R....50	57.11.4821	820 Ohm	5%	0.25W MF							
R....51	57.11.4662	5.6 kOhm	5%	0.25W MF							
R....52	58.01.8103	10 kOhm	10%	0.50W	trimming resistor						
R....53	57.11.4821	820 Ohm	5%	0.25W MF							
R....54	57.11.4223	22 kOhm	5%	0.25W MF							
R....55	57.11.4334	330 kOhm	5%	0.25W MF							

CE=Ceramic, CF=Carbon Film, EL=Electrolytic, MF=Metal Film
 PE=Polyester, PP=Polypropylen, PS=Polystyrol, SAL=Solid aluminium
 1accuard
 MANUFACTURER: Bu=Burdyn, Ex=Exor, Fc=Fairchild, GI=General Instrument
 HP=Hewlett Packard, ITT=Intermetall, Mo=Motorola
 NS=National Semiconductors, Ph=Philips, Ra=Raytheon,
 Sig=Signetics, Si=Siliconix, St=Studer,
 TI=Texas Instrument, CK=CCK

Compressor/Limiter/Noise gate

CONTENTS

page

1.	General	1
2.	Operating elements.....	2
3.	Noise gate: Release time diagram	3
4.	Compressor / Limiter: Threshold range diagram.....	3
5.	Compressor / Limiter: Attack and release time diagram	4
6.	Block diagram	5
7.	Technical data	5
8.	Circuit diagrams	7

1. General:

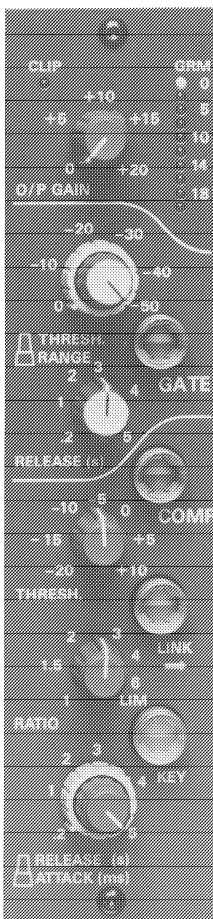

The Compressor/Limiter/Noise gate unit 1.913.155 can be installed in the instrument panel of the mixing console versions 900, 963 and 970. The unit can be routed to any input or output channel by using the insert points (insert patch panel).

The main applications of this unit are twofold:

- The Limiter/Compressor part allows a compression of the dynamic range including the limitation of the maximum output level by an adjustable limiter threshold. Attack and decay times are adjustable; the decay characteristic is additionally determined by the program structures to avoid unwanted pumping effects.
- The noise gate reduces the basic noise of connected sources in program intermissions by reducing the gain of the channel if a preset value is undershot. Further applications can be found in drum and bass recordings where a noise gate can be used to produce a dry sound with high presence character.

The use of STUDER VCA's enables a high S/N ratio with minimal distortion.

COMPRESSOR / LIMITER / NOISE GATE

2. Operating elements

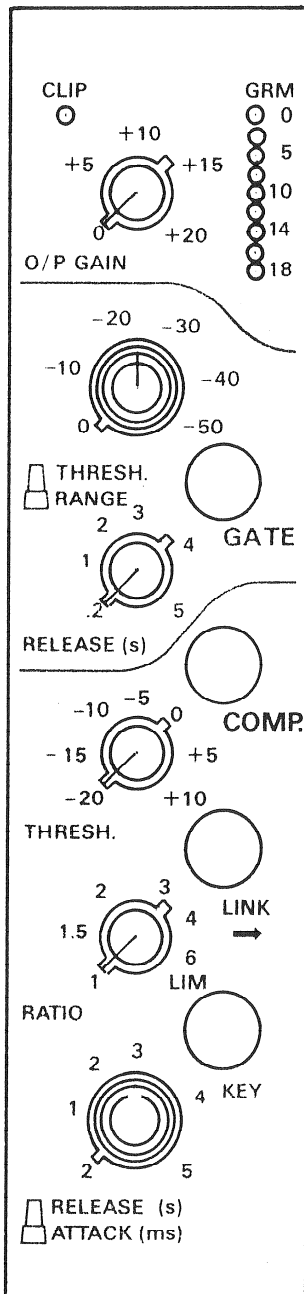
**General:**

CLIP: Overload LED

LED threshold: 2 dB below limiter threshold.

GRM: Gain reduction meter, shows gain reduction of compressor/noise gate path in dB.

GAIN: Potentiometer for increasing the output level up to 20 dB.

Noise gate:

GATE: Key to activate the noise gate.

THRESH: Noise gate threshold, adjustable in the range of 0 to -50 dB.

RANGE: Noise gate gain reduction, adjustable in the range of 0 to -50dB.

RELEASE: Time between the undershooting of the noise gate threshold and the start of the noise gate action. Adjustable range: 0.2 to 5 seconds. (see fig. 1)

Compressor / Limiter:

COMPR.: Key to activate the compressor.

LINK: Control voltage coupling with the adjacent compressor/limiter/noise gate unit on the right hand side. The higher voltage of either one takes control over both.

KEY: Key to activate the AC input voltage at the auxiliary input KEY to control the VCA gain. Applications: De-essing, voice-over, delayed gate. (see fig. 4)

THRESH: Compressor threshold, adjustable range -20 to +10 dB. (see fig. 2)

RATIO: Compression ratio, adjustable range 1:1 (no compression effect) to 20:1 (limiter effect).

ATTACK: Compressor attack time. Adjustable range 0.2 to 5 ms. (see fig. 3)

RELEASE: Compressor decay time. The scale refers to a static 6 dB gain reduction and LIM setting of ratio. The actual decay time is program dependent and optimized, thus differences to the pot position may occur. (see fig. 3)

3. Noise Gate: Release time diagram

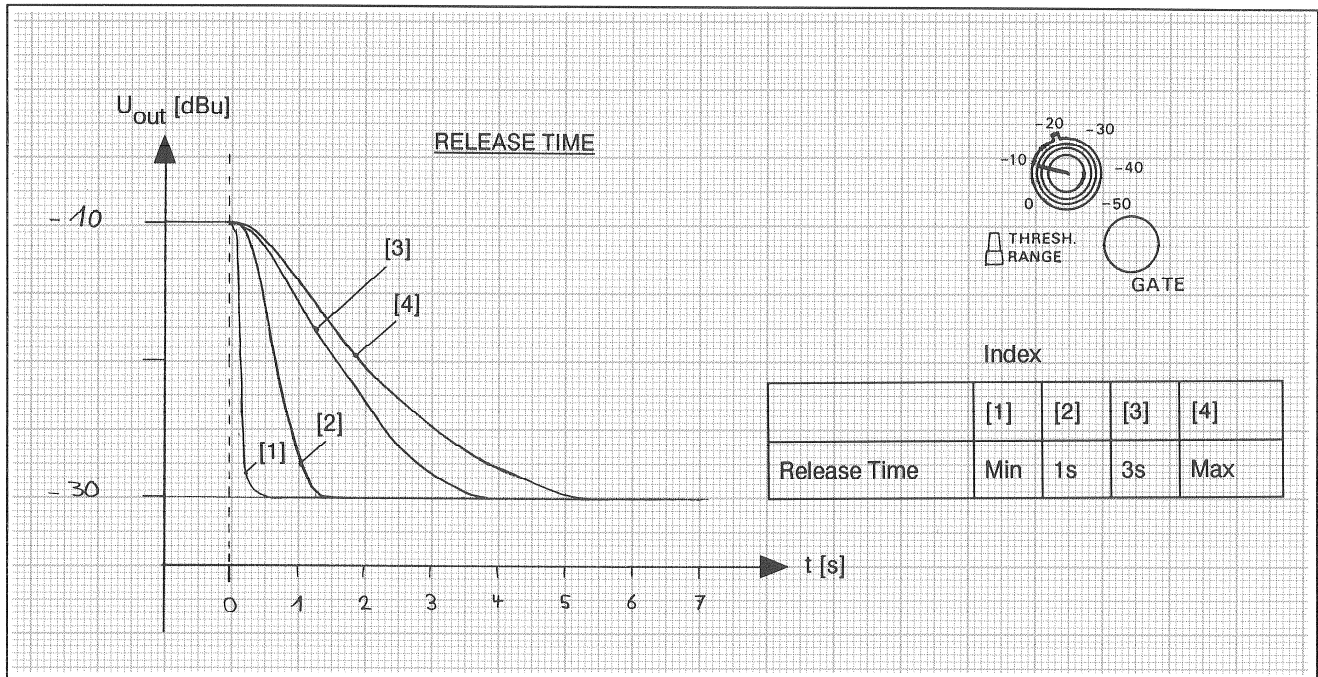

Fig. 1: Four different release time characteristics at a threshold of -10dBu and a noise gate gain reduction range of -20dBu.

4. Compressor / Limiter: Threshold range diagram

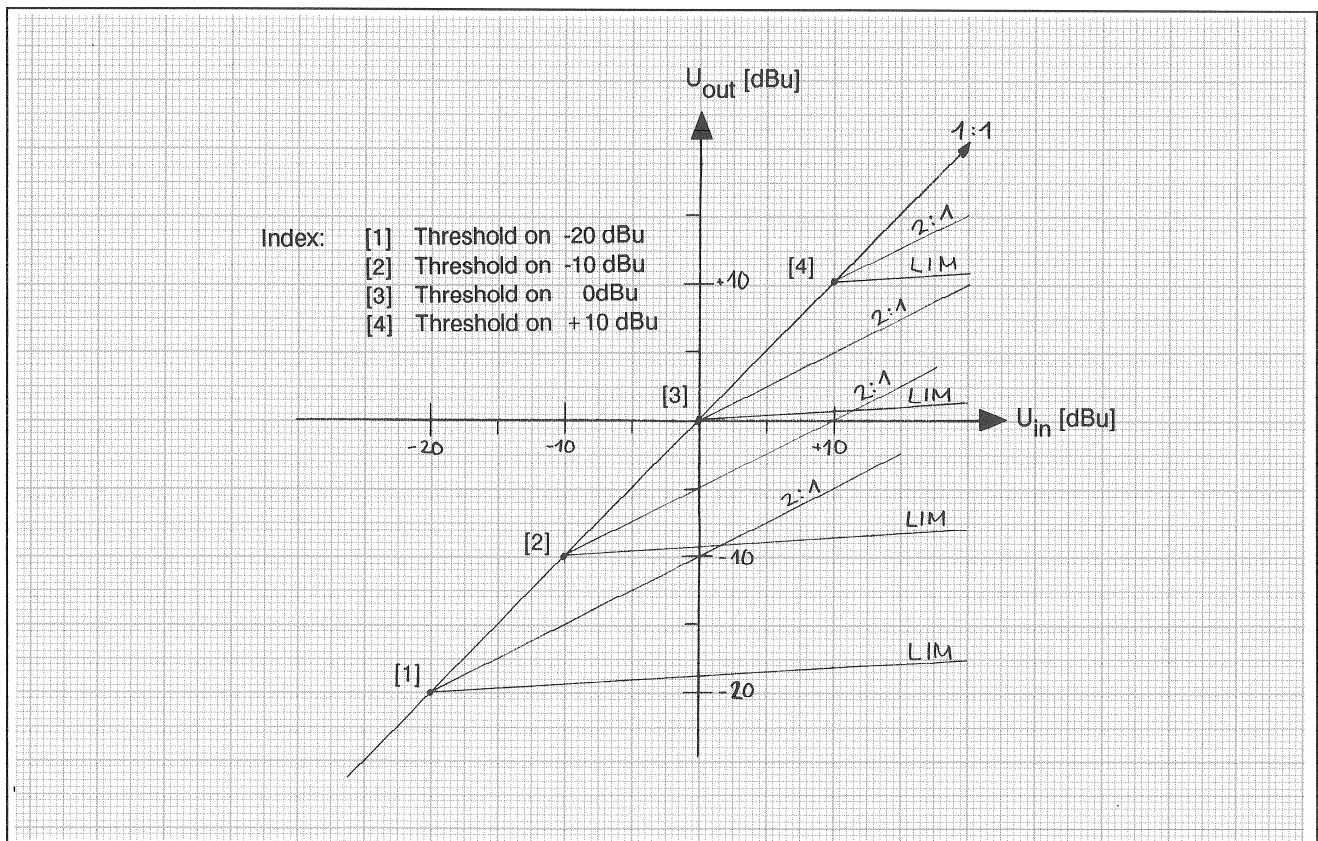

Fig. 2: Compressor threshold at four different input voltage levels (U_{in}).

5. Compressor / Limiter: Attack and release time

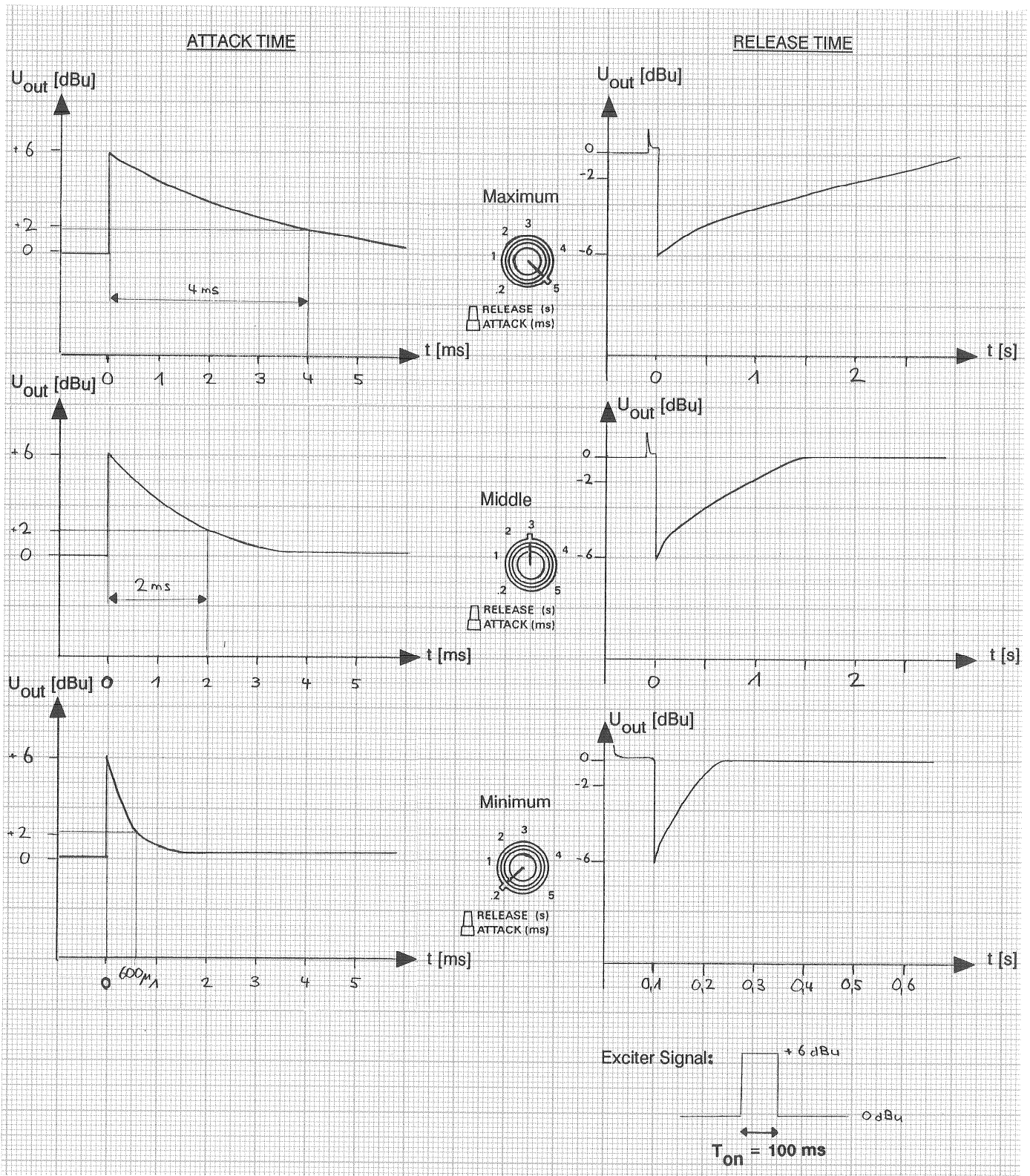

Fig. 3: The compressor/ limiter - characteristics at three different values of the attack- and release time.

6. Block diagram

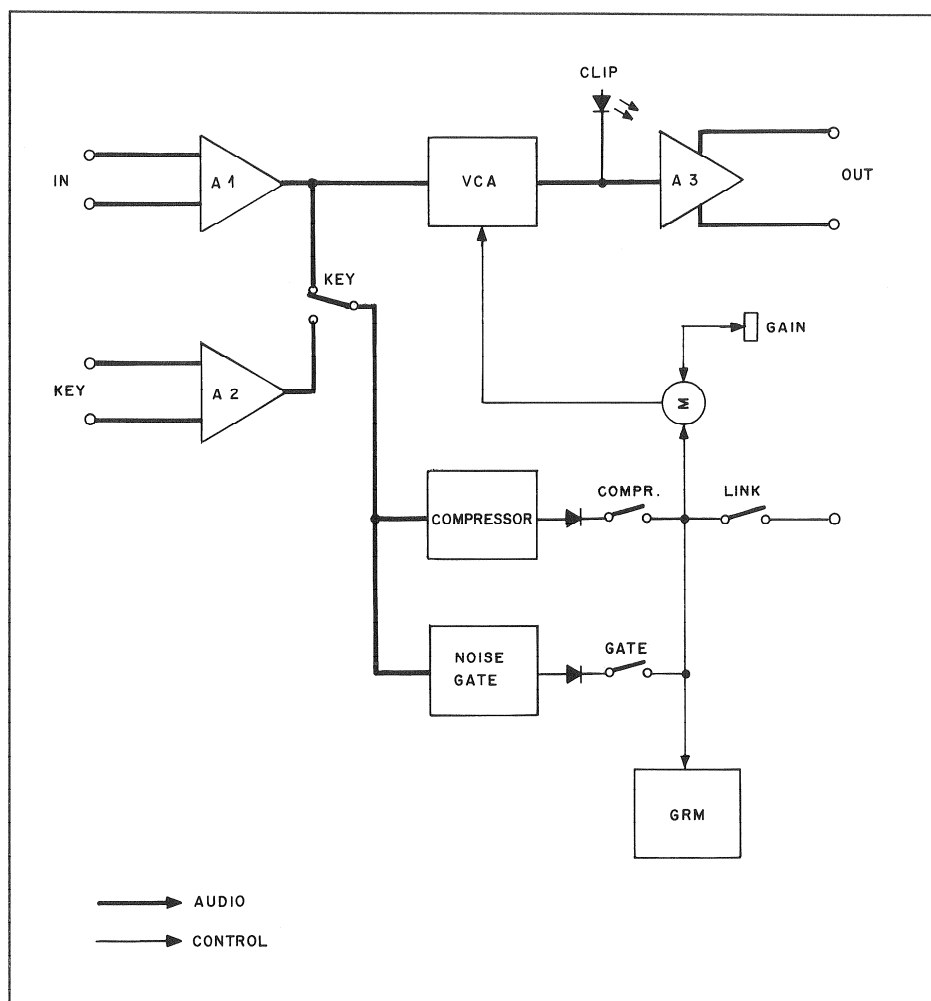

Fig. 4

7. Technical data:

Current consumption:	$\pm 15\text{ V:}$	typ. 86 mA, max. 130 mA
	-6 V:	typ. 10 mA, max. 20 mA
Frequency response:	$\leq 0.3\text{ dB}$	30 to 15.000 Hz
Noise level:	$\leq -95\text{ dBu}$	with gain 0 dB and noise gate off.
	$\leq -100\text{ dBu}$	with gain 0 dB and noise gate on.
Distortion:	$\leq -60\text{ dB}$	with input +16 dBu, output 0 dBu, threshold 0 dB, compressor on, Ratio LIM, max release time, in the range of 30 to 15.000 Hz.
Adjustments:	No service adjustments required.	

Kompressor / Limiter / Noise gate

INHALT	Seite
1. Allgemeines	1
2. Bedienungselemente	2
3. Noise-gate: Ansprechzeit Charakteristik.....	3
4. Kompressor/Limiter: Schwellenwert Diagramm	3
5. Kompressor/Limiter: Ansprech- und Rücklaufzeit	4
6. Blockschaltbild	5
7. Technische Daten	5
8. Schemateil.....	7

1. Allgemeines

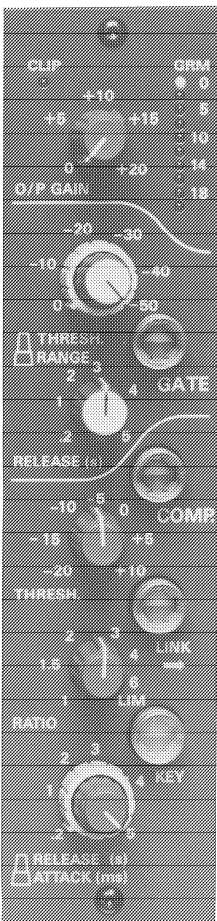

Die Kompressor / Limiter / Noise-gate Baugruppe Nr. 1.913.155 kann ins Instrumentenpanel der Mischpulte STUDER 900, 963 und 970 eingebaut werden. Unter Benützung der Einschleifpunkte (Insert patch panel) kann die Einheit auf jeden gewünschten Ein- oder Ausgangskanal geschaltet werden.

Die Baugruppe dient folgenden Hauptanwendungen:

- Der Begrenzer / Kompressor Teil erlaubt eine Kompression des Dynamikbereichs in wählbarem Ausmass. Der verstellbare Schwellenwert (threshold) ermöglicht die Begrenzung des maximalen Ausgangspegels. Die Ansprech- und Rücklaufzeiten sind frei wählbar. Um unerwünschte Pumpeffekte zu verhindern, wird die Rücklaufzeit zusätzlich von der Programmstruktur beeinflusst.
- Das Noise-gate vermindert das Grundgeräusch zugeschalteter Quellen bei Programmunterbrüchen. Die Verstärkung des betreffenden Kanals wird reduziert, sobald ein vorgewählter Signalpegel unterschritten wird. Weitere Anwendungen bieten sich bei Schlagzeug- und Bass - Aufnahmen um einen trockenen Klang mit hoher Präsenz zu erzielen.

Aus der Verwendung von STUDER VCA's resultieren der hohe Geräuschspannungsabstand und die minimalen Verzerrungen.

COMPRESSOR / LIMITER / NOISE GATE

2. Bedienungselemente

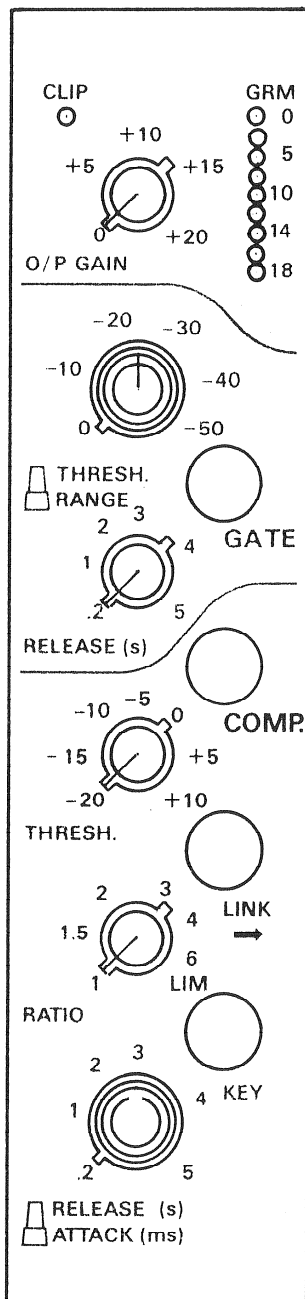
**Allgemein:**

CLIP: Übersteuerungs - Leuchtdiode
LED Schwellenwert: 2dB unterhalb der Begrenzerschwelle.

GRM: (Gain reduction meter) Anzeigeelement für die Verstärkungsreduktion des Kompressor / Noise-gate Signalweges. (in dB)

GAIN: Potentiometer zur Anpassung des Ausgangspegels bis 20 dB.

Noise-gate:

GATE.: Diese Drucktaste schaltet die Noise-gate Funktion ein bzw. aus.

THRESH.: Noise-gate Einsatzschwelle, einstellbar im Bereich von 0 bis -50dB.

RANGE: Verstärkungsreduktion des Noise-gate, einstellbar im Bereich von 0 bis -50 dB

RELEASE: Intervall vom Zeitpunkt des Unterschreitens der Noise-gate Einsatzschwelle bis zum Erreichen der vollen Noise-gate Funktion. Es ist zwischen 0,2 und 5 Sekunden einstellbar. (vgl. Fig. 1)

Kompressor / Begrenzer:

COMPR.: Drucktaste zur Aktivierung der Kompressor / Begrenzer Funktion.

LINK: Koppelung der Kompressor/Begrenzer/Noise-gate Funktionen mit der rechts benachbarten Einheit. Dabei kontrolliert die jeweils höhere Steuerungspannung beide Einheiten.

KEY: Diese Umschalttaste verwendet die Spannung des Hilfseingangs KEY für die Steuerung der VCA Verstärkung. Anwendungen: 'De-essing' (Hochtonbegrenzung), 'Voice-over' (Pegelregelung von Hintergrundmusik durch Sprechersignal), Gate mit Verzögerung.

THRESH.: Einsatzschwelle des Begrenzers einstellbar von -20 bis +10 dB. (vgl. Fig. 2)

RATIO: Das Kompressionsverhältnis [U_{in}/U_{out}] ist einstellbar von 1:1 (keine Kompressionswirkung) bis 20:1 (Begrenzerwirkung).

ATTACK: Kompressor Ansprechzeit. Einstellbereich von 0,2 bis 5 Sekunden. (vgl. Fig. 3)

RELEASE: Kompressor Rücklaufzeit. Die Skala bezieht sich auf eine konstante Verstärkungsreduktion von 6dB bei Limitereinstellung des Ratioreglers. Die wirkliche Rücklaufzeit ist programmabhängig und optimiert. Es können demzufolge Unterschiede zur Reglerposition auftreten. (vgl. Fig. 3)

3. Noise-gate: Ansprechzeit Charakteristik

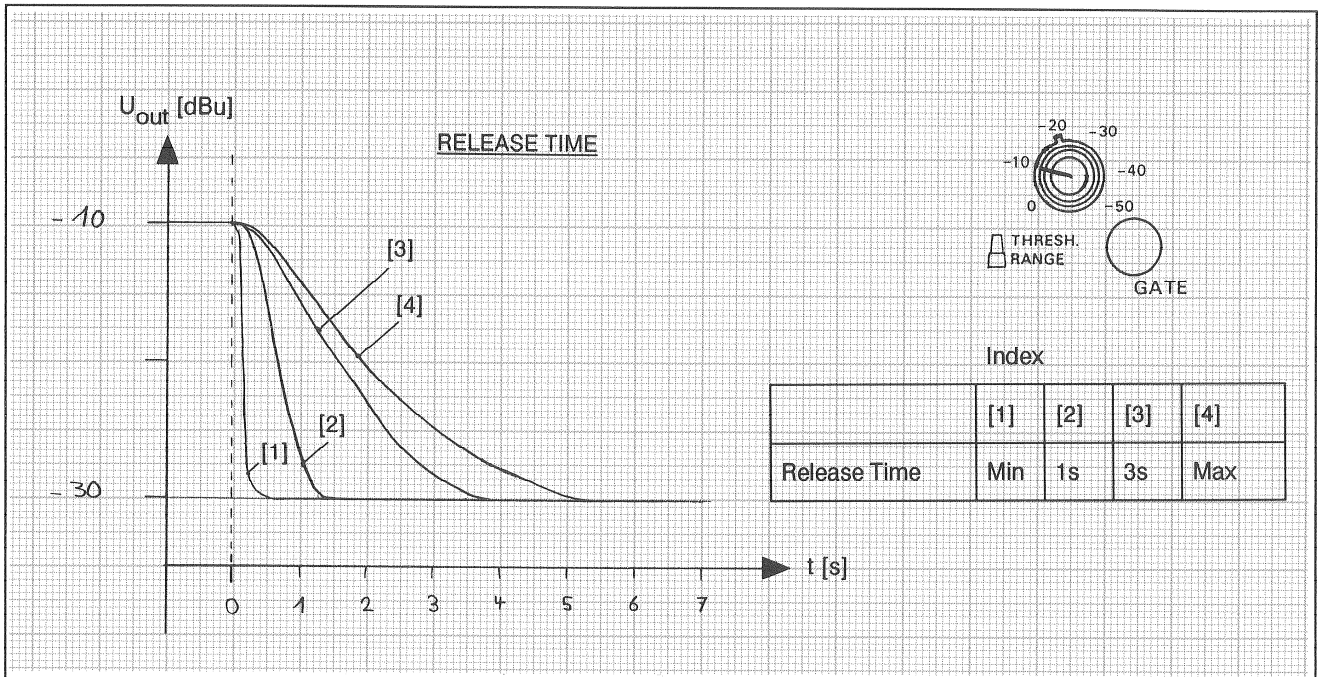

Fig. 1: Vier unterschiedliche Einstellungen der Ansprechzeit bei einem Schwellenwert von -10dBu und einer Verstärkungsreduktion (Range) von -20dBu.

4. Kompressor / Limiter: Schwellenwert Diagramm

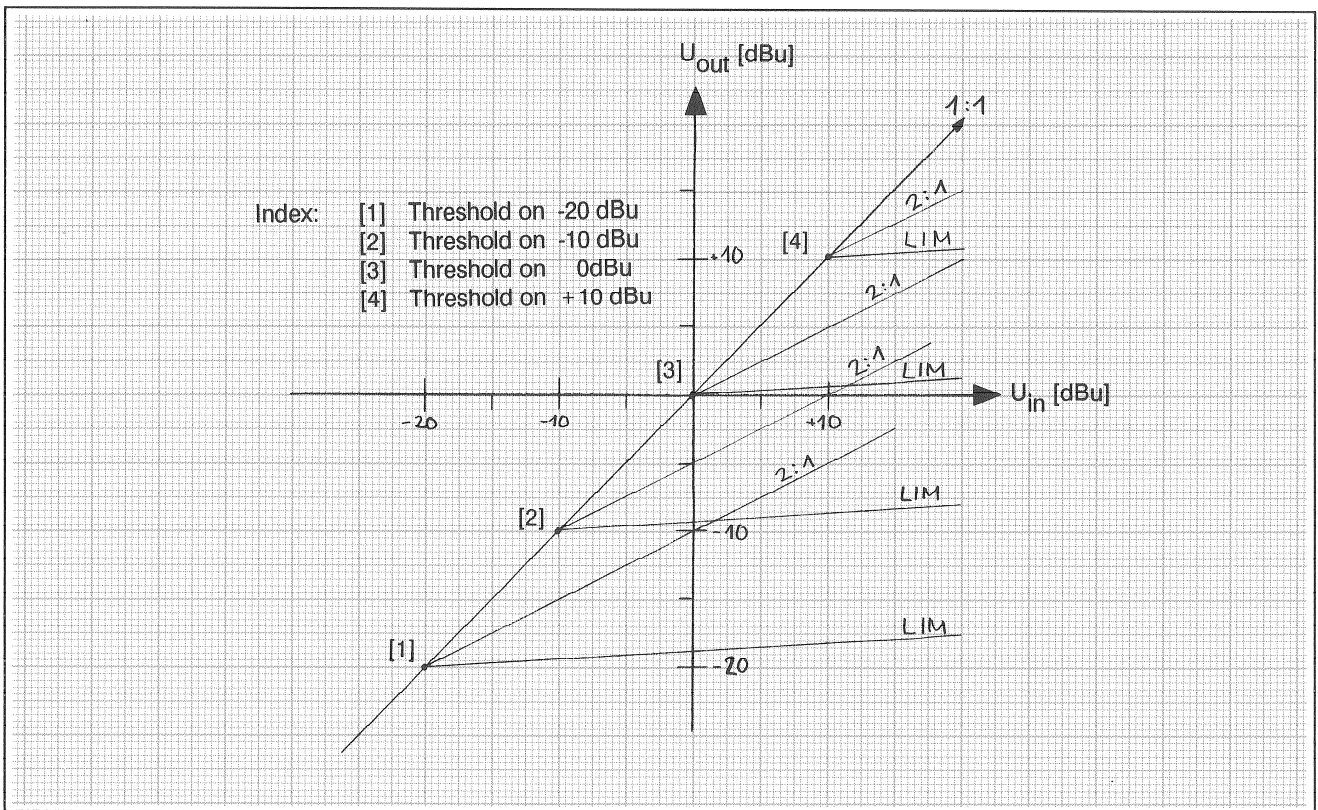

Fig. 2: Wirkung des Kompressors bei vier verschiedenen Schwellenwerten. Das Kompressionsverhältnis (Ratio) ist jeweils schwach (2:1) und maximal (Limiter) gewählt.

5. Kompressor Limiter: Ansprech- und Rücklaufzeit

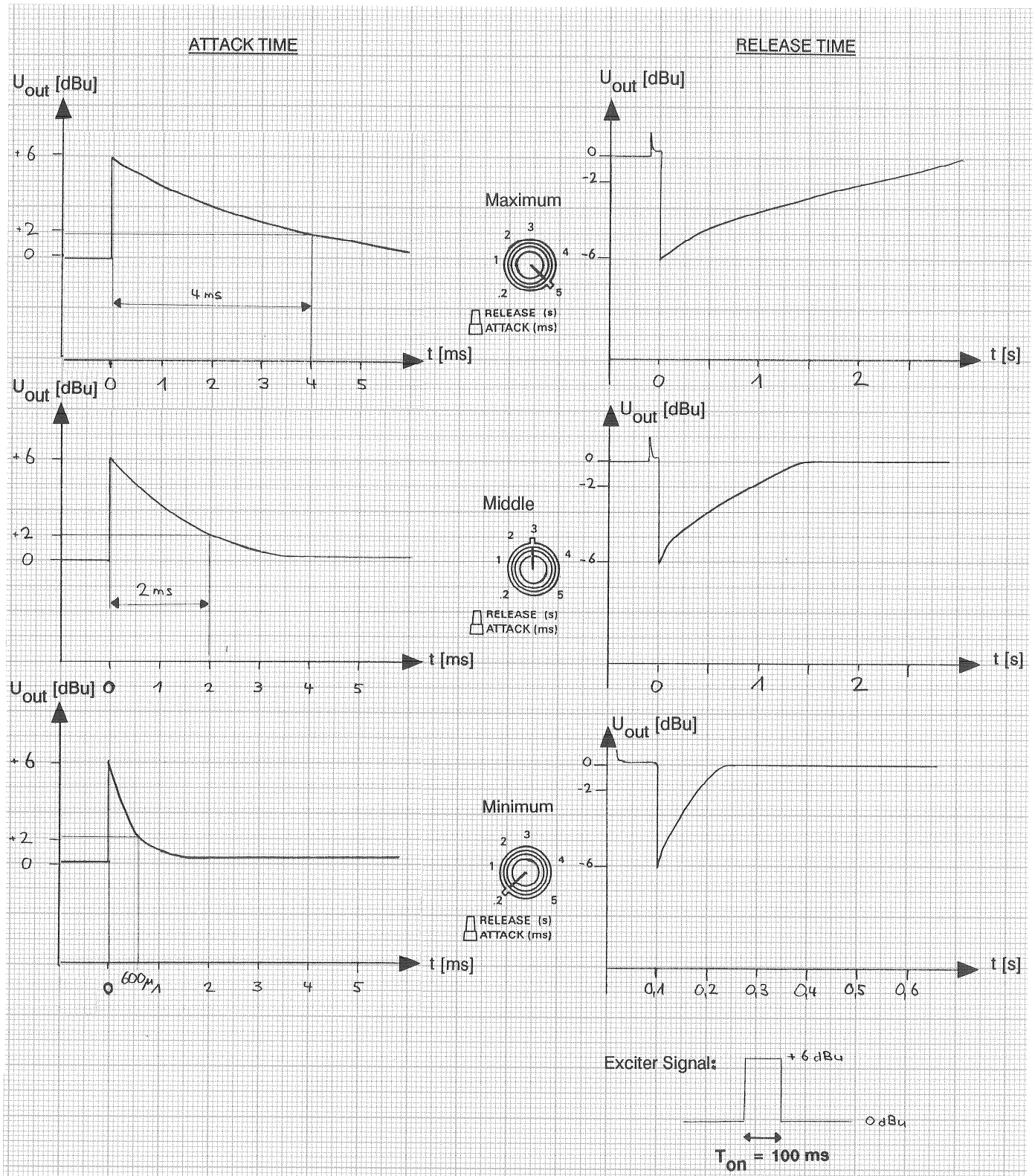

Fig. 3: Charakteristik des Kompressor / Begrenzers bei drei unterschiedlichen Werten der Ansprech- und Rücklaufzeit.

6. Blockdiagramm

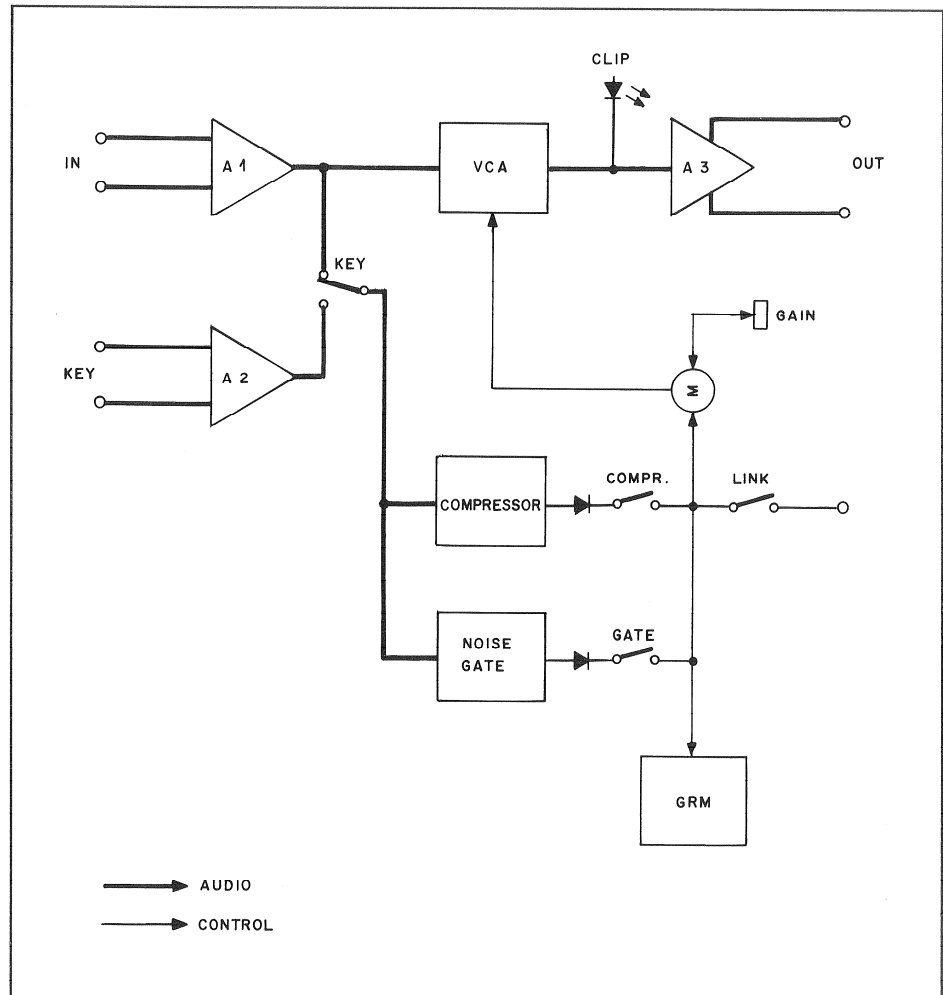

Fig. 4

7. Technische Daten

Stromaufnahme:	$\pm 15\text{ V}$: $- 6\text{ V}$	typ. 86mA, max. 130mA, typ. 10mA, max. 20mA,
Frequenzgang:	$\leq 0,3\text{dB}$	30 bis 15'000Hz
Rauschpegel:	$\leq -95\text{dBu}$ $\leq -100\text{dBu}$	bei Verstärkung 0dB und Noise-gate ausgeschaltet bei Verstärkung 0dB und Noise-gate eingeschaltet
Verzerrungen:	$\leq -60\text{dB}$	im Bereich von 30 bis 15'000Hz unter den Bedingungen: Eingang +16dBu; Ausgang 0dBu; Threshold 0dB; Kompressor ein; Ratio LIM; Release maximal;
Abgleich:	Nicht erforderlich.	

8. Circuit diagrams / Schemateil

COMPRESSOR / LIMITER / NOISE GATE

Compressor / Limiter / Noise gate 1.913.155

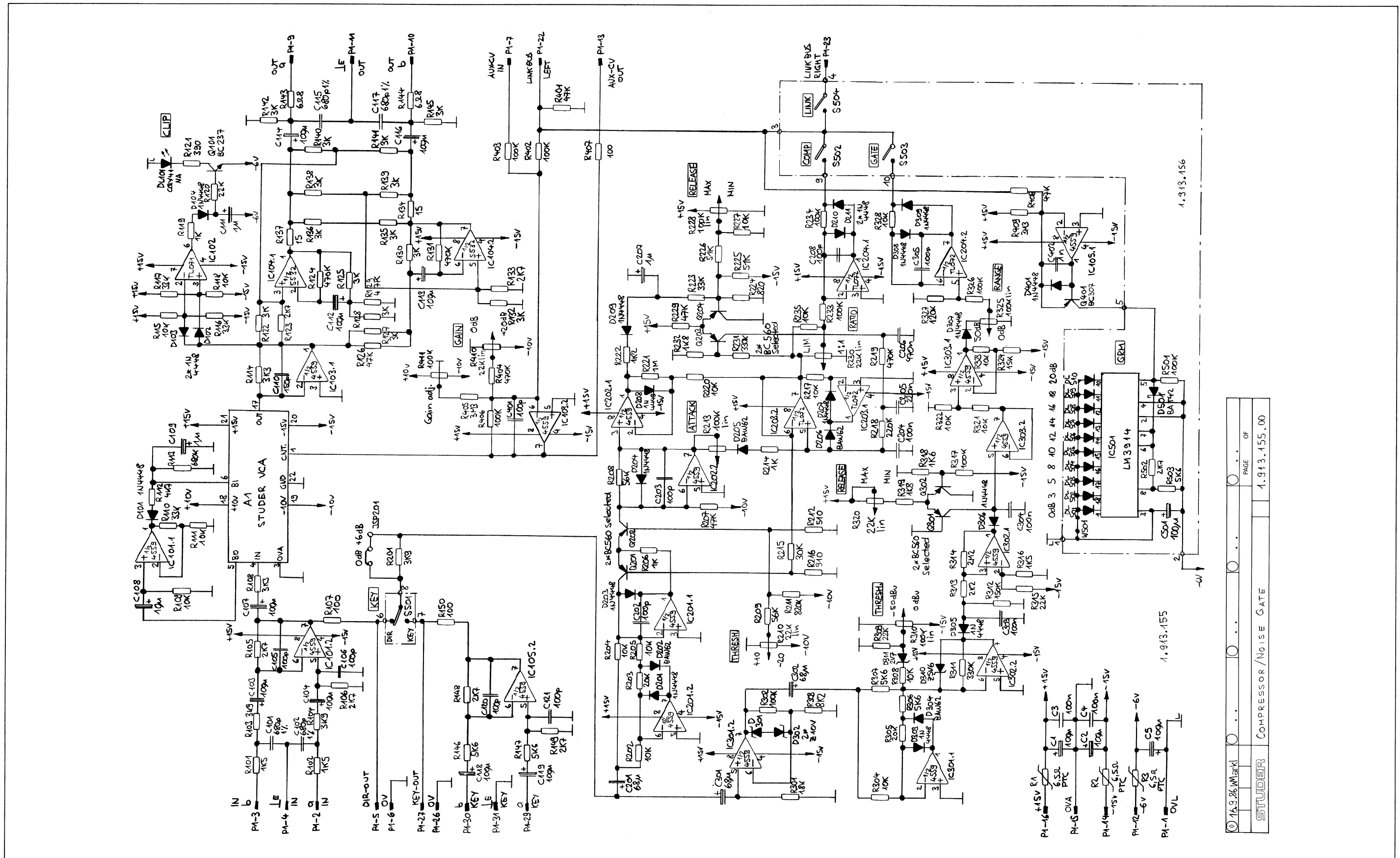

COMPRESSOR / LIMITER / NOISE GATE

Compressor / Limiter / Noise gate 1.913.155

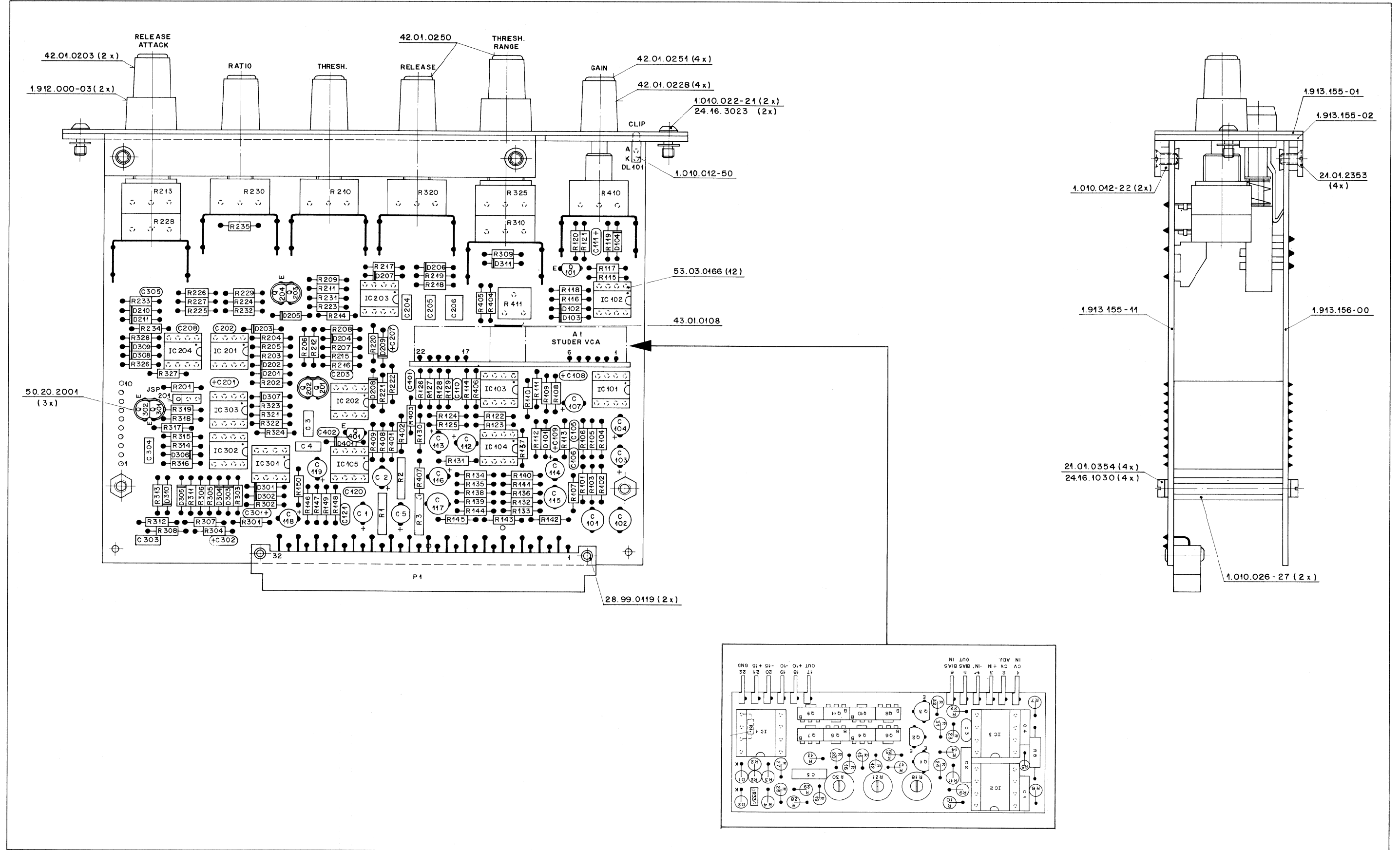

COMPRESSOR / LIMITER / NOISE GATE

Compressor Switch Board 1.913.156

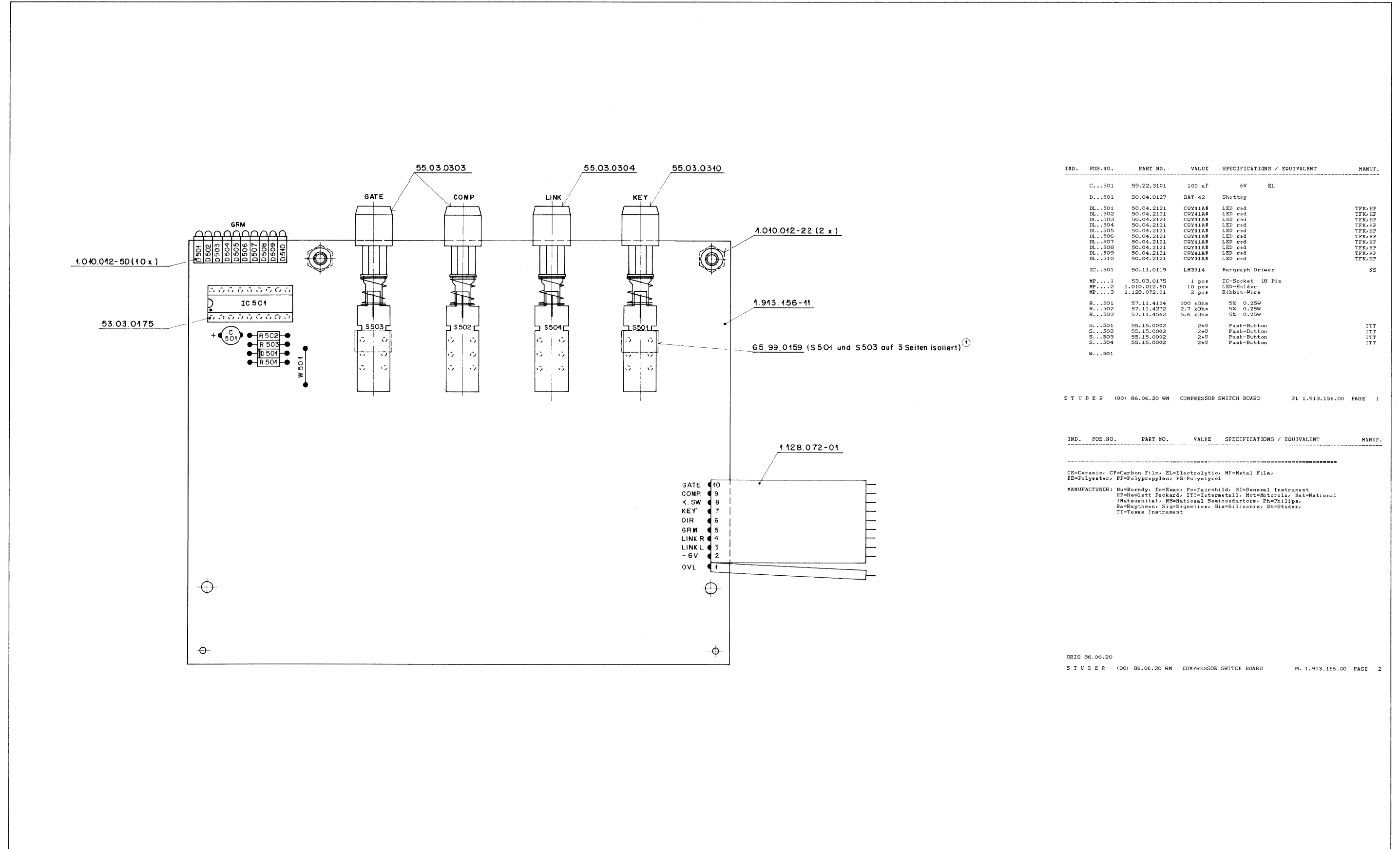

IND.	POS.NO.	PART NO.	VALUE	SPECIFICATIONS / EQUIVALENT	MANUF.
C...	501	59.22.3101	100 uF	6V EL	
D...	501	50.04.0127	BAT 42	Shottky	
DL...	501	50.04.2121	COV41A8	LED red	TFK/HP
DL...	502	50.04.2121	COV41A8	LED red	TFK/HP
DL...	503	50.04.2121	COV41A8	LED red	TFK/HP
DL...	504	50.04.2121	COV41A8	LED red	TFK/HP
DL...	505	50.04.2121	COV41A8	LED red	TFK/HP
DL...	506	50.04.2121	COV41A8	LED red	TFK/HP
DL...	507	50.04.2121	COV41A8	LED red	TFK/HP
DL...	508	50.04.2121	COV41A8	LED red	TFK/HP
DL...	509	50.04.2121	COV41A8	LED red	TFK/HP
DL...	510	50.04.2121	COV41A8	LED red	TFK/HP
IC...	501	50.11.0119	LM3914	Barograph Driver	NS
MP...	1	53.03.0175	1 pcs	IC-Socket 18 Pin	
MP...	2	1.010.012.50	10 pcs	LED-Holder	
MP...	3	1.128.072.01	2 pcs	Ribbon-Wire	
R...	501	57.11.4104	100 kOhm	5% 0.25W	
R...	502	57.11.4272	2.7 kOhm	5% 0.25W	
R...	503	57.11.4562	5.6 kOhm	5% 0.25W	
S...	501	55.15.0002	2xU	Push-Button	ITT
S...	502	55.15.0002	2xU	Push-Button	ITT
S...	503	55.15.0002	2xU	Push-Button	ITT
S...	504	55.15.0002	2xU	Push-Button	ITT
W...	501				

S T U D E R (00) 86.06.20 WM COMPRESSOR SWITCH BOARD PL 1.913.156.00 PAGE 1

IND.	POS.NO.	PART NO.	VALUE	SPECIFICATIONS / EQUIVALENT	MANUF.

CE=Ceramic, CF=Carbon Film, EL=Electrolytic, MF=Metal Film,					
PE=Polyester, PP=Polypolyphen, PS=Polystyrol					
MANUFACTURER: Bu=Burrndy, Ex=Emar, Fo=Fairchild, GI=General Instrument					
HP=Hewlett Packard, ITT=Intermetall, Mo=Motorola, Nat=National					
(Matsushita), NS=National Semiconductors, Ph=Philips,					
Ra=Raytheon, Sig=Signetics, Six=Siliconix, St=Studer,					
TI=Texas Instrument					

ORIG 86.06.20
S T U D E R (00) 86.06.20 WM COMPRESSOR SWITCH BOARD PL 1.913.156.00 PAGE 2

LIM./COMPR./NOISE G.
1.913.155

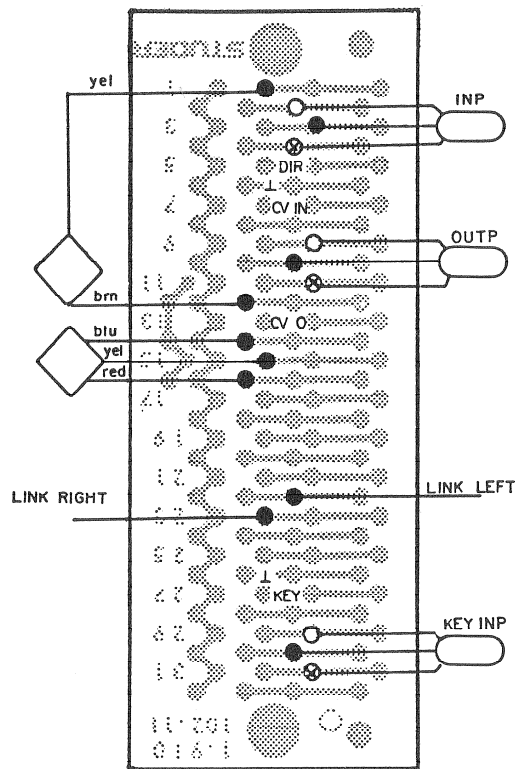

P

LIM./COMPR./NOISE G.
1.913.155

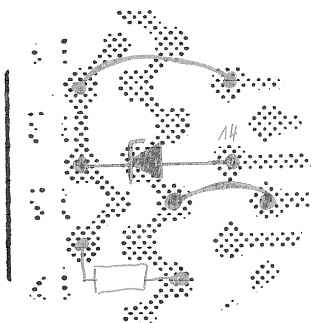
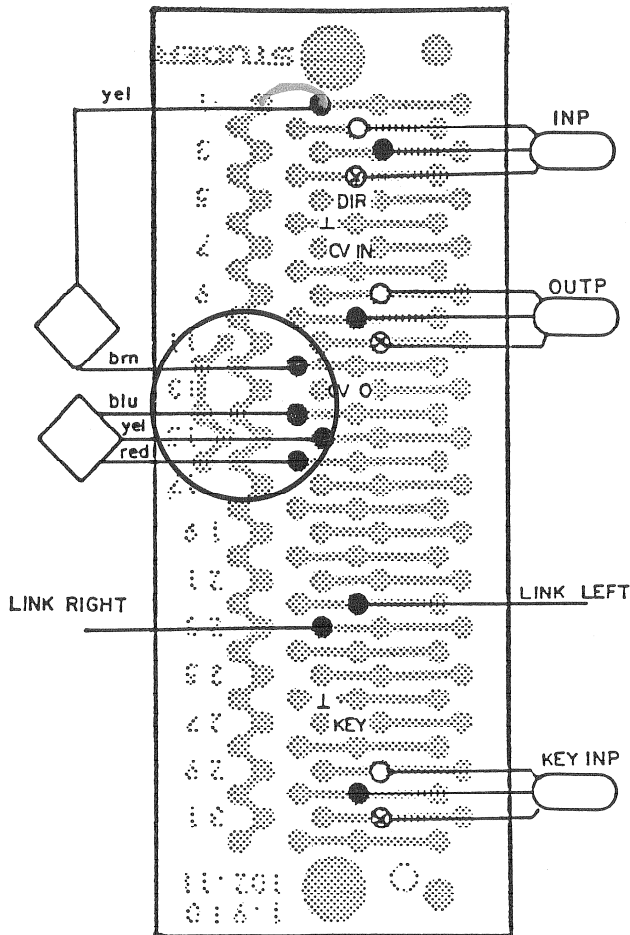

$R = 1k2 \Omega$
 $ZD = 9V1 \quad 1,3W$

08.02.99	Zd
		Print 1.910.102.M			PAGE OF
STUDER		Limiter Compressor			

LIM./COMPR./NOISE G.
1.913.155

LIM./COMPR./NOISE G.
1.913.155

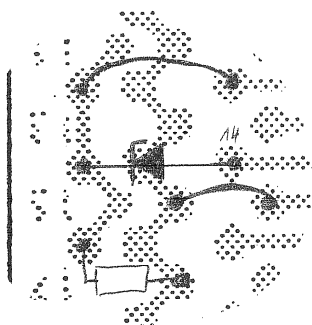
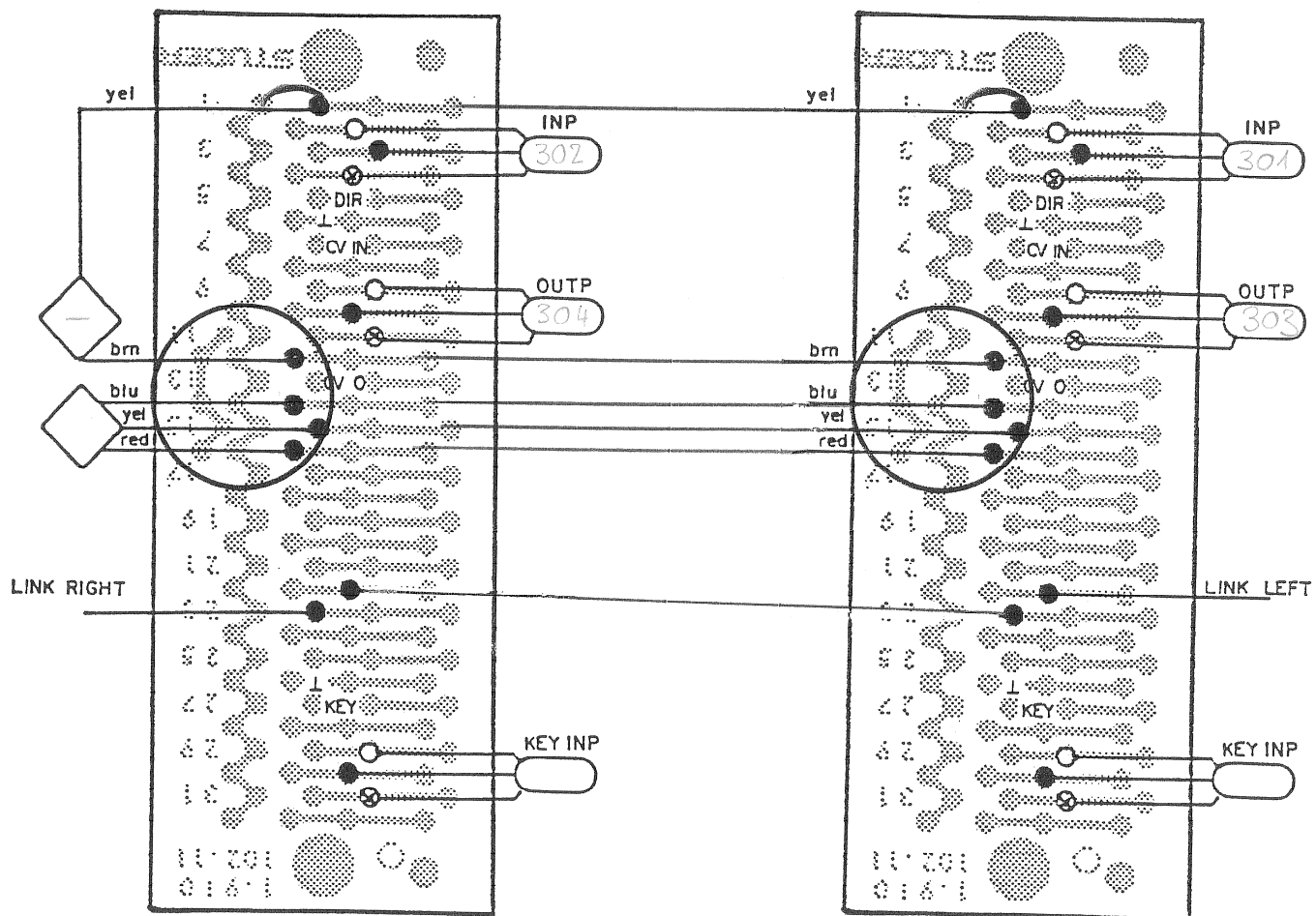

$R = 1k2 \Omega$
 $ZD = 9VA \ 1,3W$

① . . .	○ . . .	○ . . .	○ . . .	○ . . .
	Print 1.510.102.11			PAGE OF
STUDER	Limiter Compressor			

LIMITER / COMPRESSOR 2

LIMITER / COMPRESSOR 1

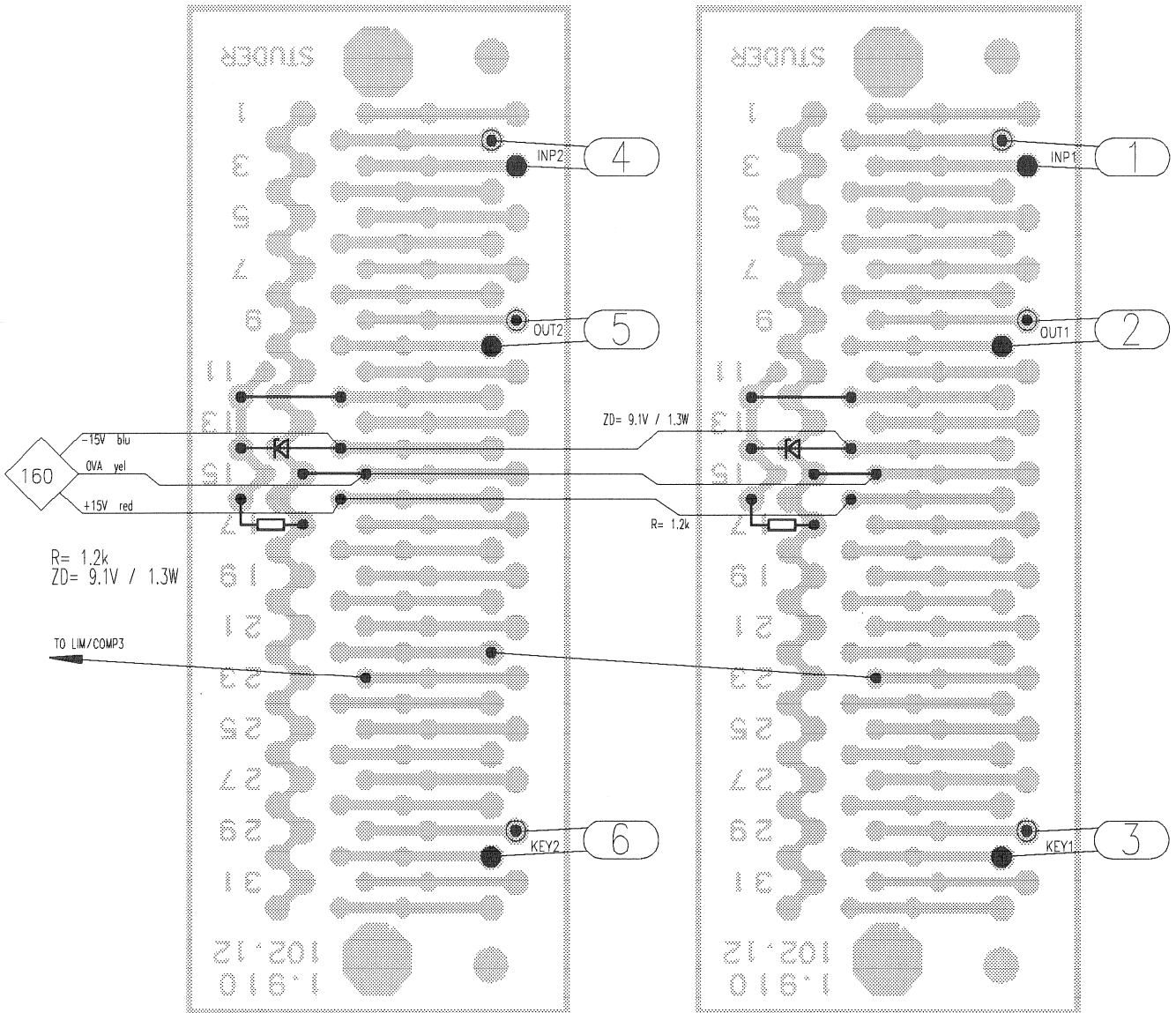

P:\ACAD\Busboards\BOARDS\910\91010212lc_w.dwg

07.06.00 / GY			
91010212lc_w	MUSTER		Page 1 of 1
STUDER REGENSDORF SWITZERLAND	LIMITER / COMPRESSOR		MUSTER

SAMMELSCHIENEN ANWAHL 9...16BUS SELECTOR 9...16 CHSAMMELSCHIENEN ANWAHL 9...24BUS SELECTOR 9...24 CH

Die Sammelschieneanwahl-Einheit enthält Tasten, um das Eingangssignal auf 9...16 oder 9...24 aufzuschalten. Drei Mono Hilfsausgänge (Aux 5..7) und ein Stereo Hilfsausgang (Aux 8) sind ebenfalls eingebaut.

The bus selector-unit comprises buttons to switch the input signal to 9...16 or 9...24 master buses.

Three mono (Aux 5...7) and 1 stereo-aux-outputs (Aux 8) are also built-in.

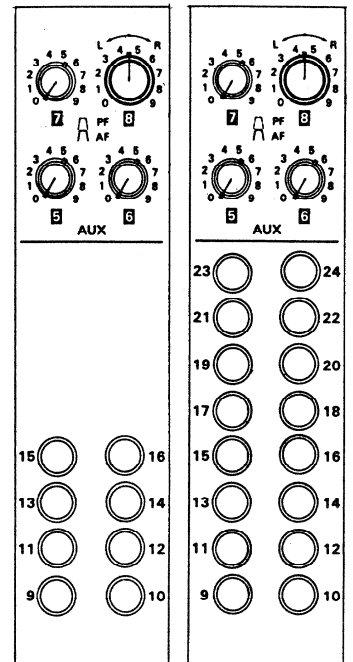
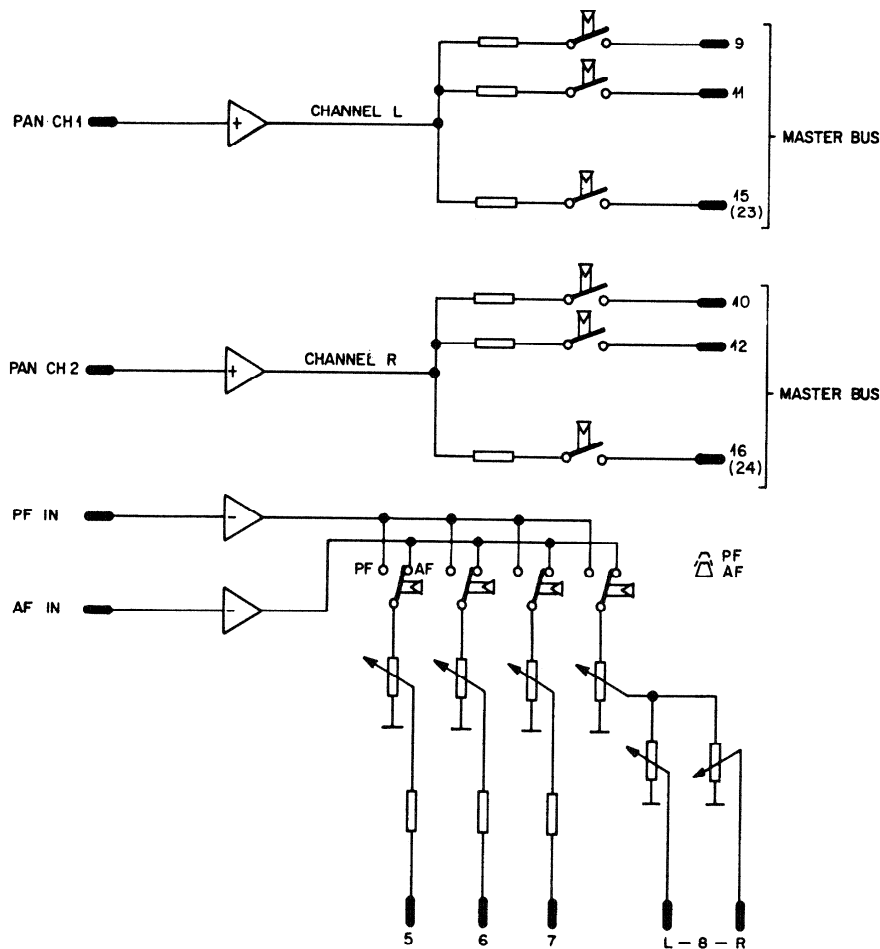
BLOCKSCHALTBILDBLOCK DIAGRAMTECHNISCHE DATEN

Speisespannungen

MECHANISCHE DATEN

Frontplatte dunkelgrau gespritzt

Abmessungen Frontplatte

Tiefe

Gewicht

SPECIFICATIONS

Supply

+15 V 30mA

DIMENSIONS

Front panel laquered charcoal grey

Dimensions of front panel

170x40 mm

Depth

135 mm

Weight

300 gr

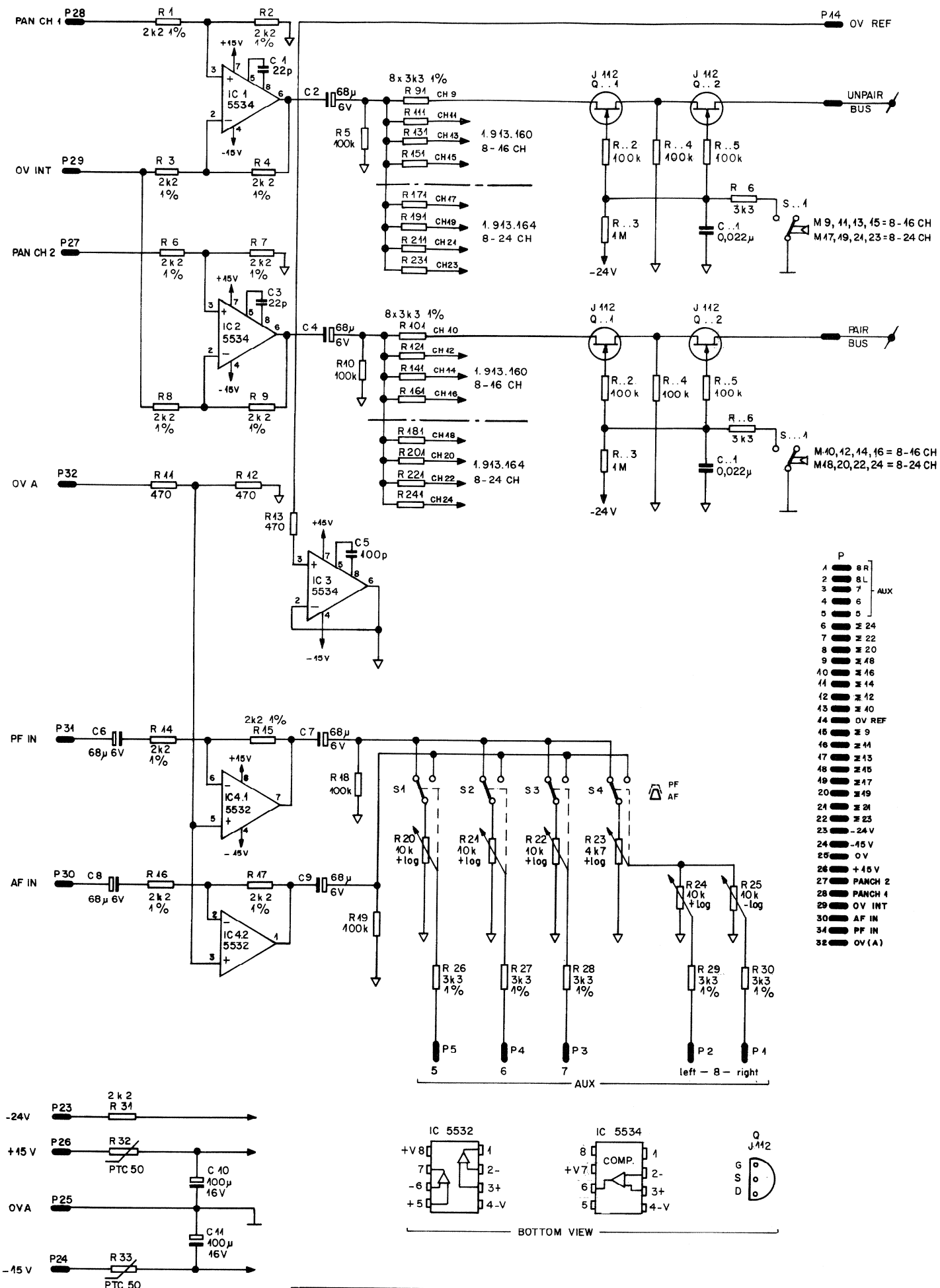

DATE:	47.11.82	45.11.83	18.7.84	4.10.84	
SIGN:	<i>ge</i>	<i>ge</i>	<i>ml</i>	<i>ml</i>	
STUDER REGENSDORF ZÜRICH	BUS SELECTOR		9-16 CH	SC 1.913.160	
			9-24 CH	SC 1.913.164	

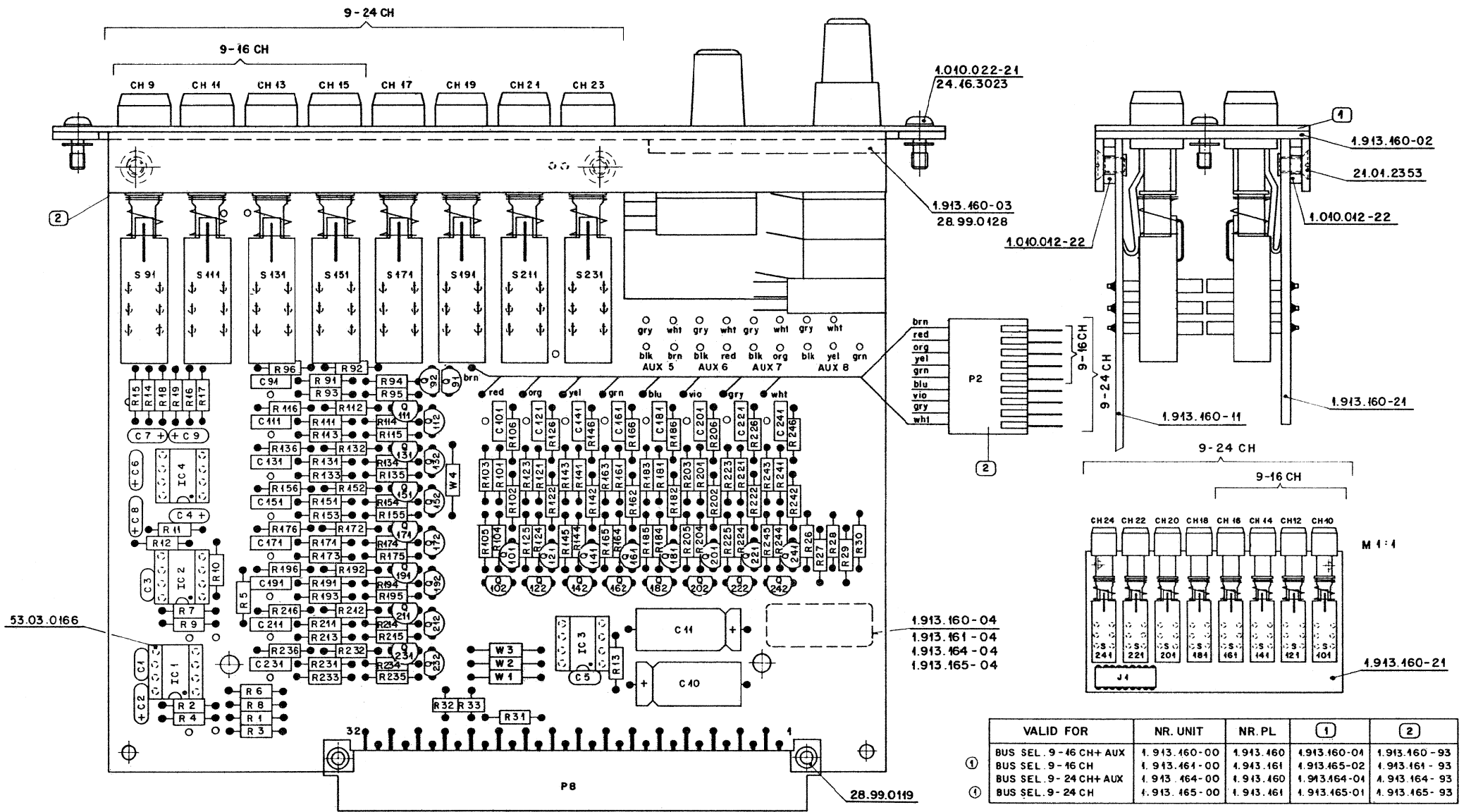

	VALID FOR	NR. UNIT	NR. PL	(1)	(2)
①	BUS SEL. 9-16 CH+ AUX	1.913.460-00	1.913.460	1.913.460-04	1.913.460-93
	BUS SEL. 9-16 CH	1.913.461-00	1.913.461	1.913.465-02	1.913.461-93
①	BUS SEL. 9-24 CH+ AUX	1.913.464-00	1.913.460	1.913.464-04	1.913.464-93
	BUS SEL. 9-24 CH	1.913.465-00	1.913.461	1.913.465-01	1.913.465-93

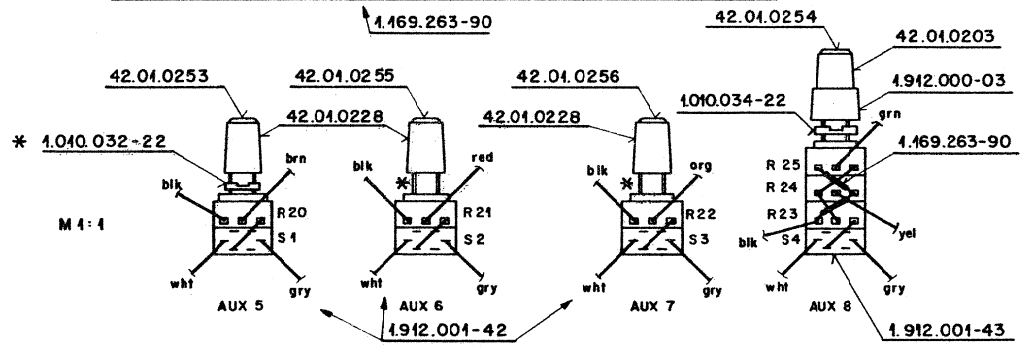

Werkstoff:	Norm-Nr.:	Güte:	22.40.85A.Ho <i>Vf Vf</i> ③		
DIN-Bez.:		Beh.:	1.4.84 A.Ho <i>Vf Vf</i> ②		
Abmessung:			3.2.83 A.Ho <i>Vf Vf</i> ①		
Zugehörige Unterlagen:	Freimasttoleranz:	Maßstab:	5.4.83 A.Ho <i>Vf Vf</i> ④		
Ersatz für:	Ersetzt durch:	Datum Gez. Gepr. Ges. Index			
Ersatz für:		Ersetzt durch:		Kopie für:	
STUDER REGENSDORF ZÜRICH		Benennung: Bus Selector 9-16 CH		Nummer: 1.913.160-00	

IND	POS NO	PART NO	VALUE	SPECIFICATIONS/EQUIVALENT	MFR
C 1	59.34.2220	22 pF			CER
C 2	59.26.0680	68 μF	6V		SAL
C 3	59.34.2220	22 pF			CER
C 4	59.26.0680	68 μF	6V		SAL
2 C 5	59.34.4101	100 pF			CER
C 6	59.26.0680	68 μF	6V		SAL
C 7	59.26.0680	68 μF	6V		SAL
C 8	59.26.0680	68 μF	6V		SAL
C 9	59.26.0680	68 μF	6V		SAL
C 10	59.25.3101	100 μF	16V		EL
C 11	59.25.3101	100 μF	16V		EL
IC 1	50.05.0244	MS534AN		Low noise	Si,Te,R
IC 2	50.05.0244	MS534AN		Low noise	Si,Te,R
IC 3	50.05.0244	MS534AN		Low noise	Si,Te,R
IC 4	50.09.0106	MS532AN		Low noise	Si,Te,R
R 1	57.11.3222	2k2	1%		
R 2	57.11.3222	2k2	1%		
R 3	57.11.3222	2k2	1%		
R 4	57.11.3222	2k2	1%		
R 5	57.11.4104	100 k			
R 6	57.11.3222	2k2	1%		
R 7	57.11.3222	2k2	1%		
R 8	57.11.3222	2k2	1%		
R 9	57.11.3222	2k2	1%		
R 10	57.11.4104	100k			
R 11	57.11.4471	470	2%		
R 12	57.11.4471	470	2%		
R 13	57.11.4471	470			

IND	DATE	NAME			
④					
③					
②	4.10.84	JG	CER - CERAMIC	Si - SIGNETICS	
①	18.7.84	W	SAL - SOLID ALUMINUM	Te - TEXAS	
○	25.10.82	JG	EL - ELECTROLYTIC	R - RAYTHEON	
			9-24 CH	1.913.164.00	
STUDER	BUS SELECTOR	9-16 CH	PL	1.913.160.00	PAGE 1 OF 3

IND	POS NO	PART NO	VALUE	SPECIFICATIONS/EQUIVALENT	MFR
R..1	57.11.3332	3k3	1%		
① R..2	57.11.4104	100kΩ			
R..3	57.11.4105	1MΩ			
R..4	57.11.4104	100kΩ			
① R..5	57.11.4104	100kΩ			
R..6	57.11.3332	3k3			
S..1	55.15.0002	2 XU		SWITCH	Schadow
	65.03.0303	GREY		KNOB RED INDIC	Schadow
	42.01.0228	GREY		KNOB 10/4	
	42.01.0253	RED		COVER	
	42.01.0254	BLUE		COVER	
	42.01.0255	YELLOW		COVER	
	42.01.0256	GREEN		COVER	
J	54.01.0305	CIS 5P			
P	54.01.0359	32 P		2 x 16 EURO PRINT	
	53.03.0166			XIC DIL 8P	

IND	DATE	NAME			
④					
③					
②	4.10.84	JG			
①	18.7.84	W			
○	25.10.82	JG	9-24 CH	1.913.164.00	
STUDER	BUS SELECTOR	9-16 CH	PL	1.913.160.00	PAGE 3 OF 3

IND	POS NO	PART NO	VALUE	SPECIFICATIONS/EQUIVALENT	MFR
R 14	57.11.3222	2k2	1%		
R 15	57.11.3222	2k2	1%		
R 16	57.11.3222	2k2	1%		
R 17	57.11.3222	2k2	1%		
R 18	57.11.4104	100k			
R 19	57.11.4104	100k			
R 20	1.912.001.42	10k		pos. Log	
R 21	1.912.001.42	10k		pos. Log	
R 22	1.912.001.42	10k		pos. Log	
R 23	1.912.001.43	10k		pos. Log	
R 24	1.912.001.43	10k		pos. Log	
R 25	1.912.001.43	10k		pos. Log	
R 26	57.11.3332	3k3	1%		
R 27	57.11.3332	3k3	1%		
R 28	57.11.3332	3k3	1%		
R 29	57.11.3332	3k3	1%		
R 30	57.11.3332	3k3	1%		
R 31	57.11.3222	2k2			
R 32	57.99.0206	50		PTC	
R 33	57.99.0206	50		PTC	

CHANNEL ELEMENT		9	11	13	15	17	19	21	23	10	12	14	16	18	20	22	24
	W	9.	11.	13.	15.	17.	19.	21.	23.	10.	12.	14.	16.	18.	20.	22.	24.
		P-16CH				P-24CH				P-16CH				P-24CH			
C..1	59.06.0223	0.022μF															
Q..1	50.02.0350	JM2	JM2F-18/JM2A														
Q..2	50.03.0350	JM2	JM2F-18/JM2A														

IND	DATE	NAME			
④					
③					
②	4.10.84	JG			
①	18.7.84	W			
○	25.10.82	JG	9-24 CH	1.913.164.00	
STUDER	BUS SELECTOR	9-16 CH	PL	1.913.160.00	PAGE 2 OF 3

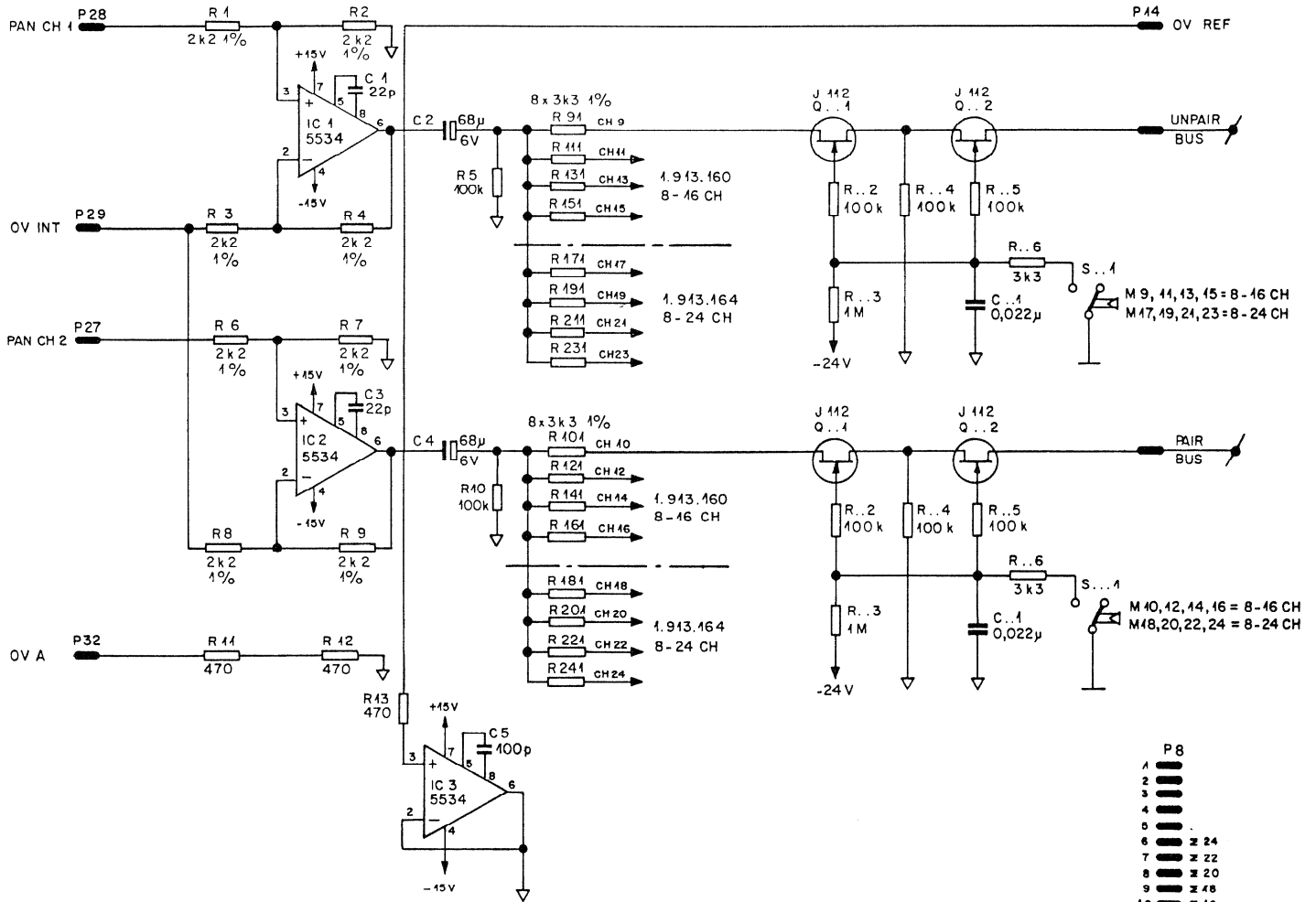

- P8
- 1
 - 2
 - 3
 - 4
 - 5
 - 6
 - 7
 - 8
 - 9
 - 10
 - 11
 - 12
 - 13
 - 14
 - 15
 - 16
 - 17
 - 18
 - 19
 - 20
 - 21
 - 22
 - 23
 - 24
 - 25
 - 26
 - 27
 - 28
 - 29
 - 30
 - 34
 - 32

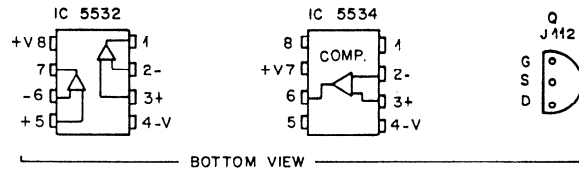
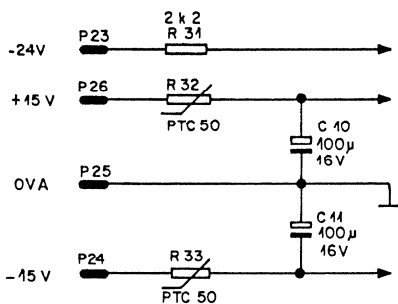

DATE:	26.3.84	18.7.84	4.10.84		
SIGN:	<i>ml</i>	<i>ml</i>	<i>ml</i>		
STUDER REGENSDORF ZURICH	BUS SELECTOR		9-16 CH	SC 1.913.161	
			9-24 CH	SC 1.913.165	

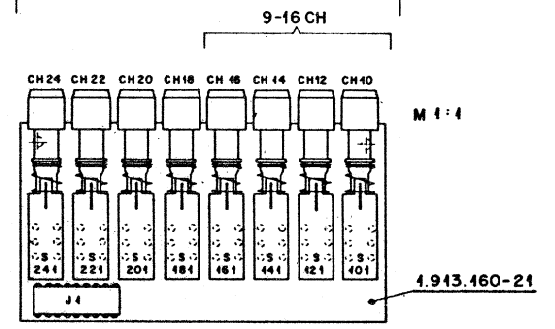
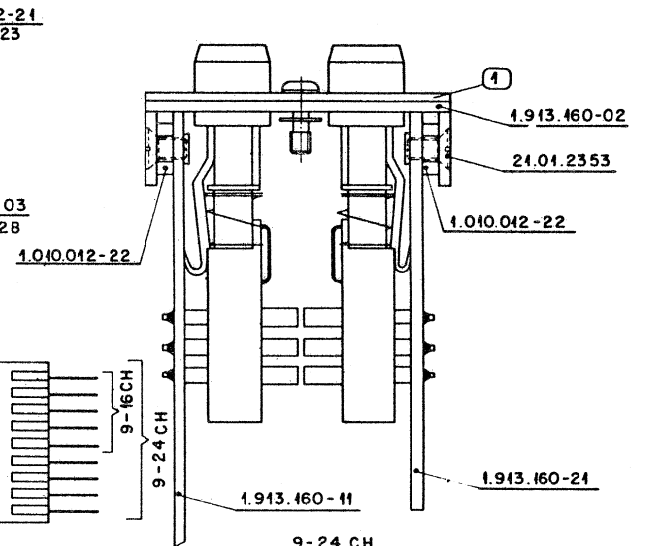
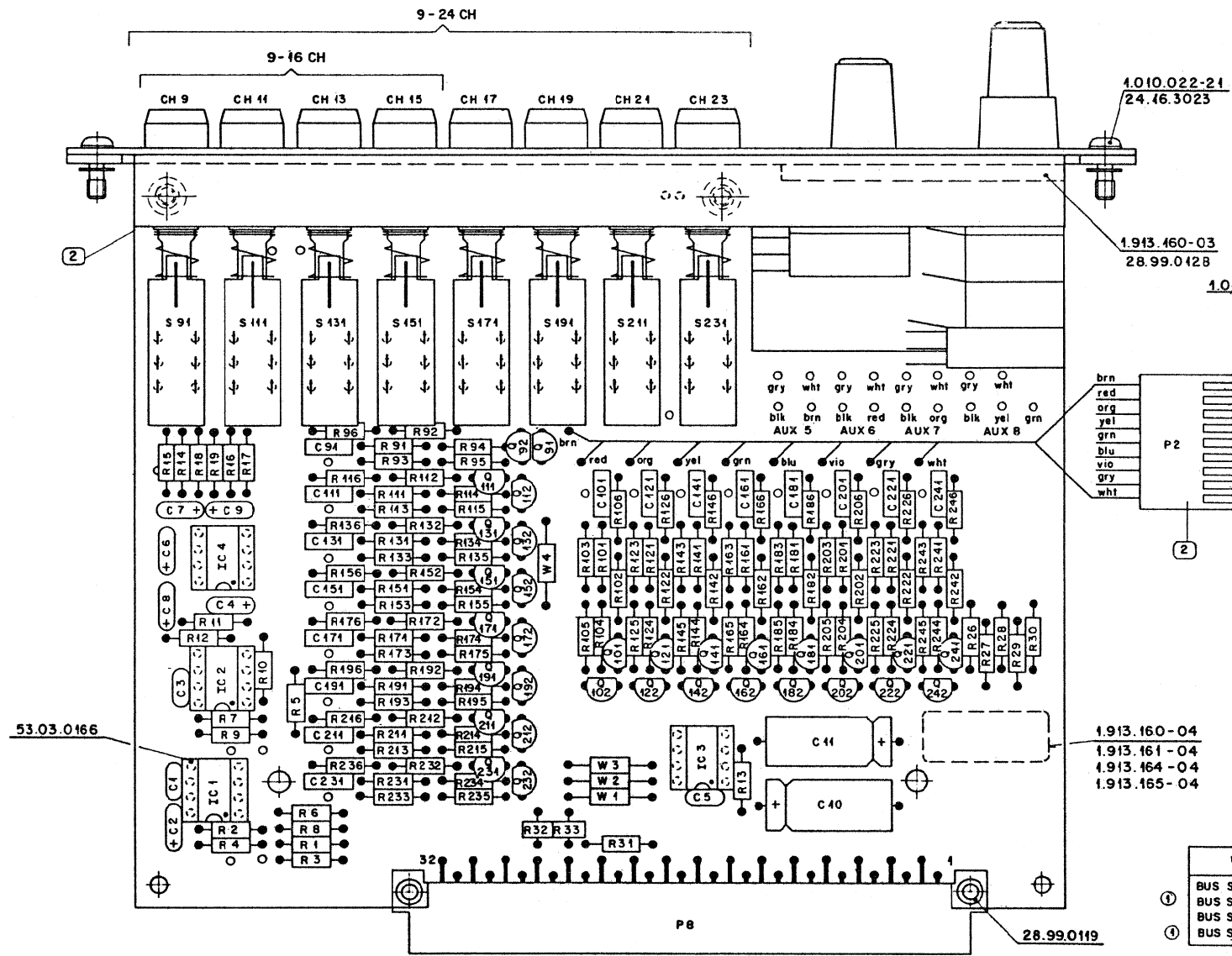

VALID FOR	NR. UNIT	NR. PL	(1)	(2)
BUS SEL. 9-16 CH + AUX	1.913.160-00	1.913.160	1.913.160-04	1.913.160-93
BUS SEL. 9-16 CH	1.913.161-00	1.913.161	1.913.165-02	1.913.161-93
BUS SEL. 9-24 CH + AUX	1.913.164-00	1.913.164	1.913.164-04	1.913.164-93
BUS SEL. 9-24 CH	1.913.165-00	1.913.165	1.913.165-01	1.913.165-93

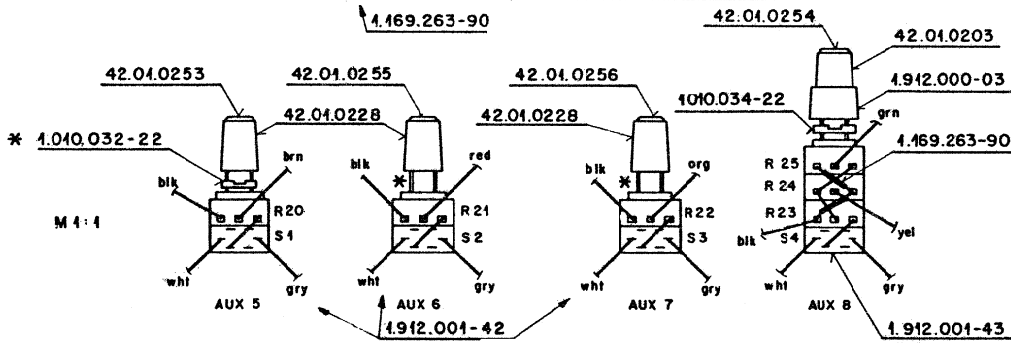

Werkstoff:	Norm-Nr.:	Oberteile:	Güte:	Änderung:
DIN-Bes.:		Beh.:		22.10.85 A.Ho <i>W</i> ③
Abmessung:				14.84 A.Ho <i>W</i> ②
Zugehörige Unterlagen:	Freimasstoleranz:	Maßstab:		3.2.83 A.Ho <i>W</i> ①
Ersatz für:	Ersetzt durch:	Kopie für:		5.1.83 A.Ho <i>W</i> ④
STUDER REGENSDORF ZÜRICH		Benennung: Bus Selector 9-16 CH		Nummer: 1.913.160-00

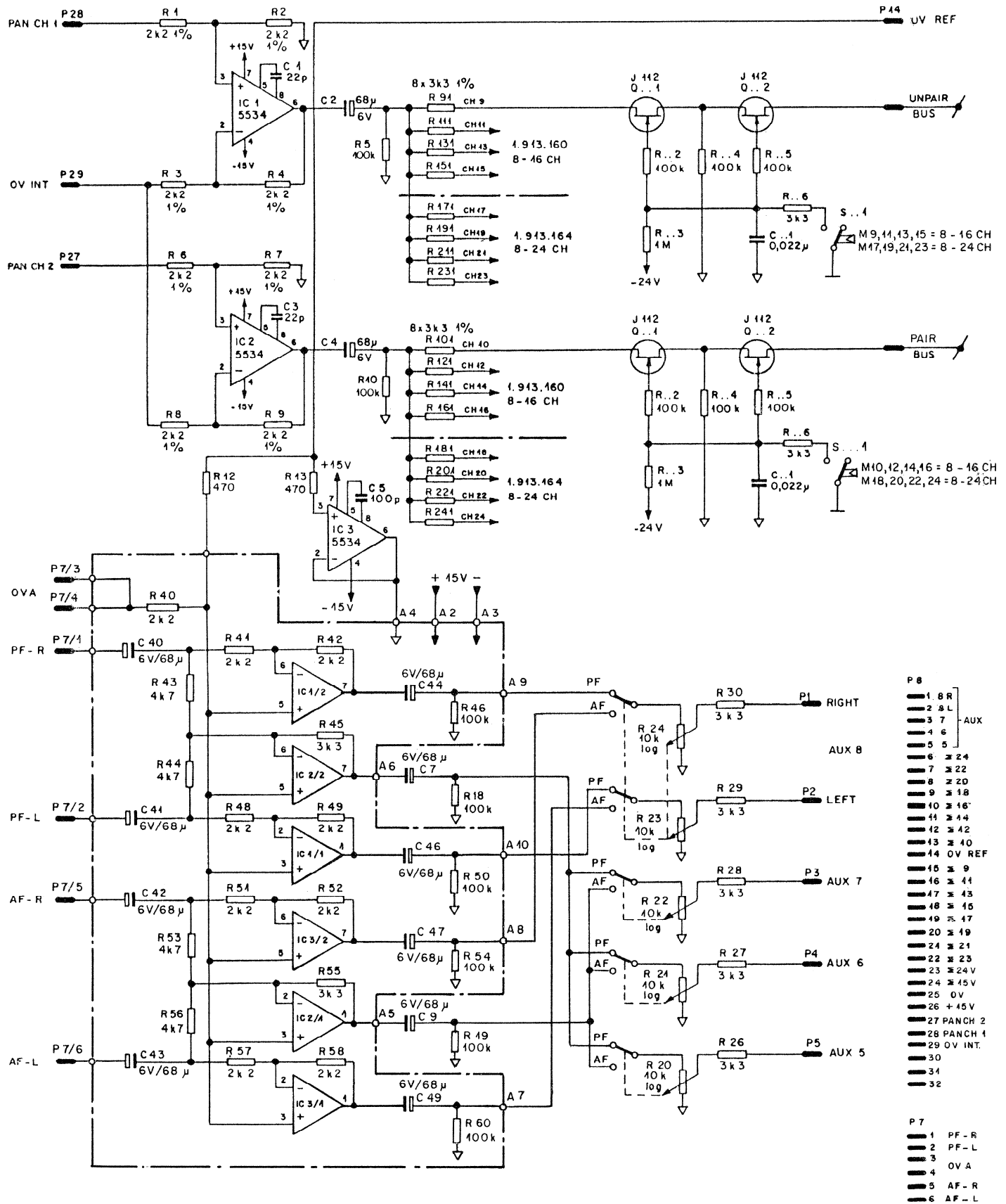

- P 8**
- 1 8 R
 - 2 8 L
 - 3 7
 - 4 6
 - 5 5
 - 6 24
 - 7 22
 - 8 20
 - 9 18
 - 10 16
 - 11 44
 - 12 42
 - 13 40
 - 14 OV REF
 - 15 9
 - 16 41
 - 17 43
 - 18 15
 - 19 17
 - 20 19
 - 21 21
 - 22 23
 - 23 24V
 - 24 45V
 - 25 OV
 - 26 +15V
 - 27 PANCH 2
 - 28 PANCH 1
 - 29 OV INT.
 - 30
 - 31
 - 32
- P 7**
- 1 PF - R
 - 2 PF - L
 - 3 OV A
 - 4 AF - R
 - 5 AF - L
 - 6 AF - L

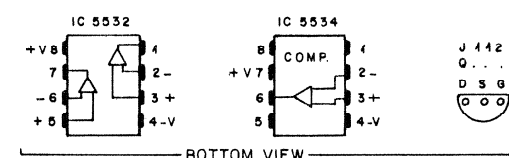
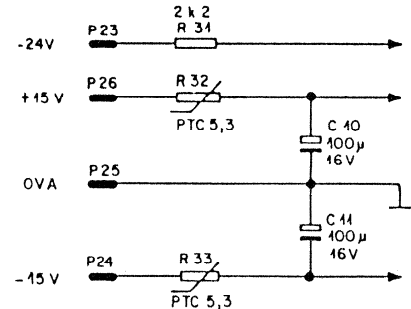

DATE:	40.10.90			
SIGN:				
STUUBOER REGENSDORF ZURICH	BUS SELECTOR STEREO			SC 1.913.163

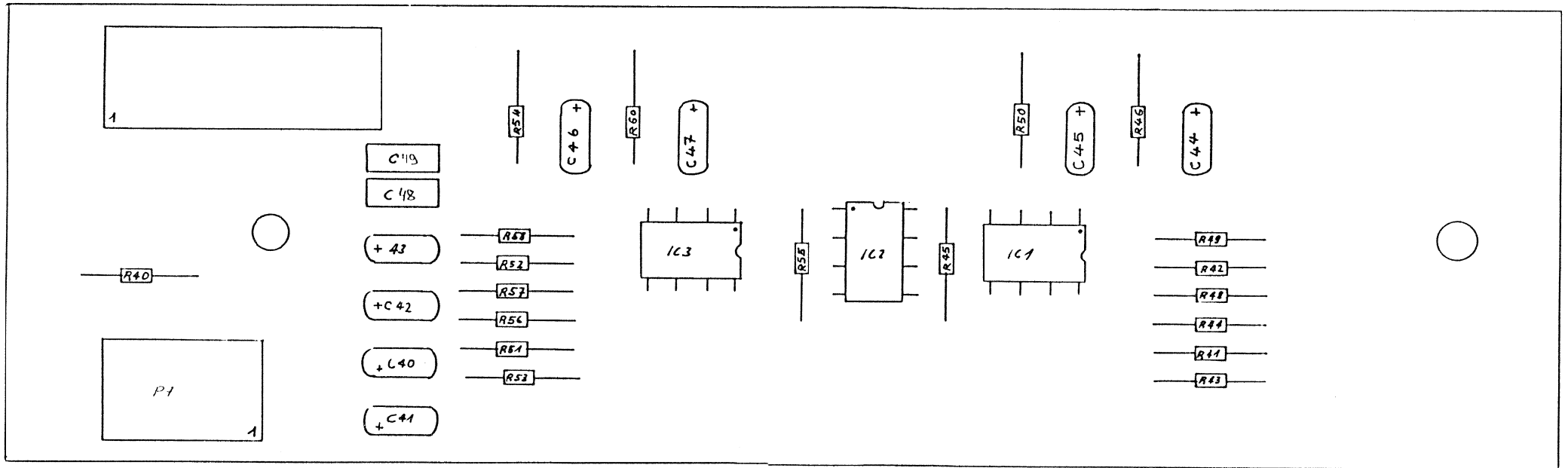

1.913.163.11

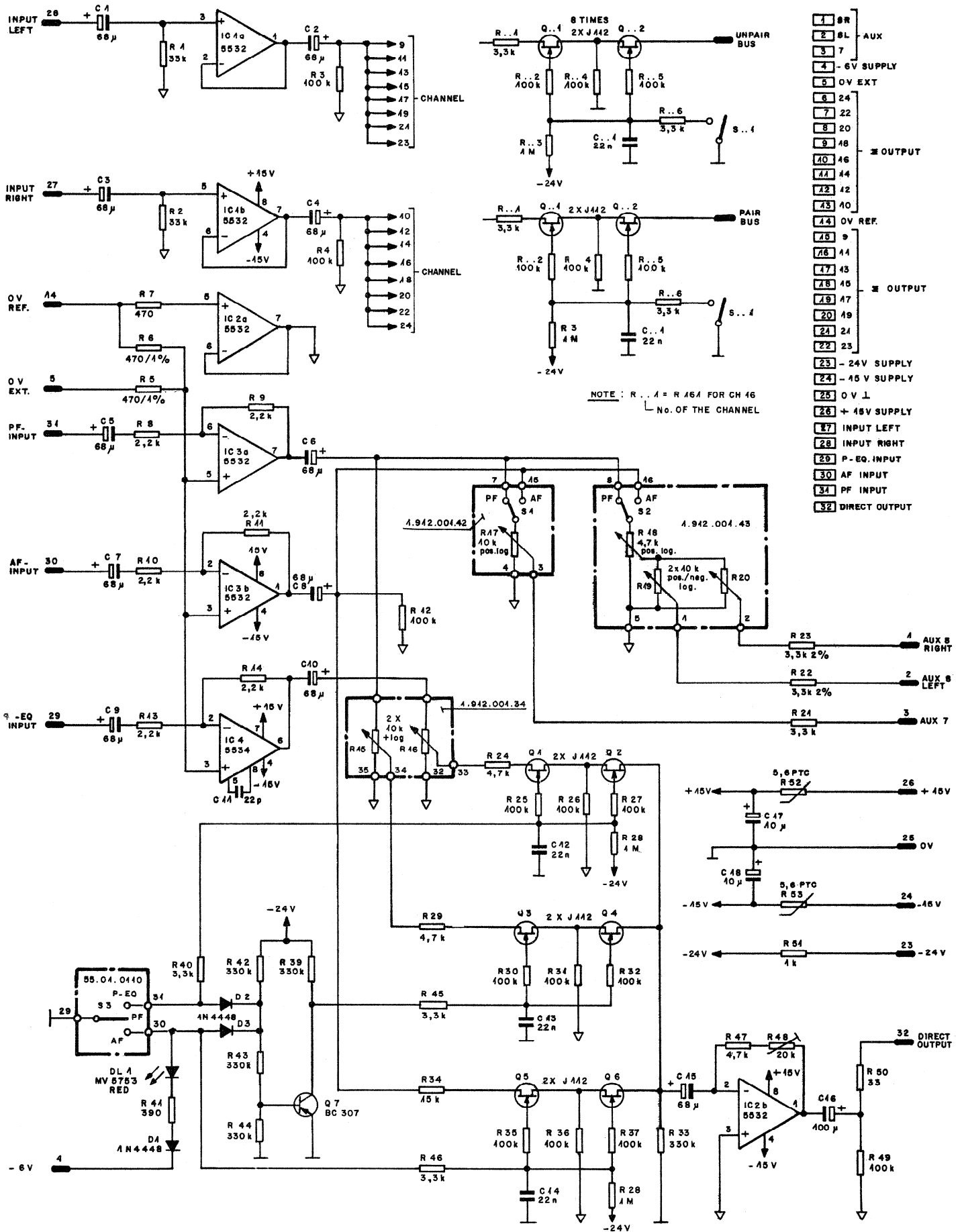

① 24.8.83 <i>Wk</i>	② 27.5.86 <i>Wk</i>	○	○
STUDER REGENSDORF ZÜRICH		9...16 CH 9...24 CH	SC 1.913.162 SC 1.913.166

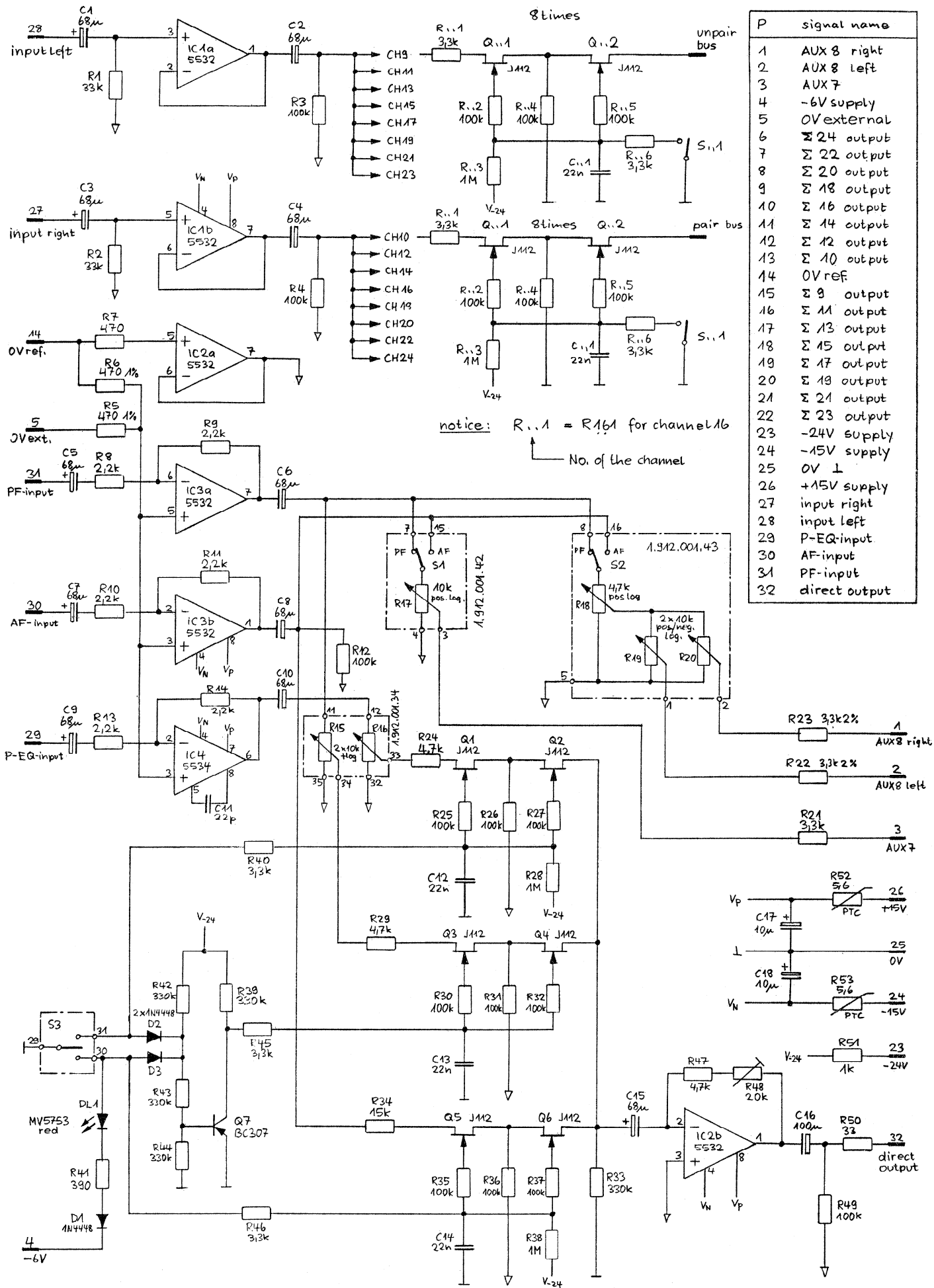

P	signal name
1	AUX 8 right
2	AUX 8 left
3	AUX 7
4	-6V supply
5	0V external
6	Σ 24 output
7	Σ 22 output
8	Σ 20 output
9	Σ 18 output
10	Σ 16 output
11	Σ 14 output
12	Σ 12 output
13	Σ 10 output
14	0V ref
15	Σ 9 output
16	Σ 11 output
17	Σ 13 output
18	Σ 15 output
19	Σ 17 output
20	Σ 19 output
21	Σ 21 output
22	Σ 23 output
23	-24V supply
24	-15V supply
25	0V ⊥
26	+15V supply
27	input right
28	input left
29	P-EQ-input
30	AF-input
31	PF-input
32	direct output

notice: R_{1.1} = R₁₆₁ for channel 16
 No. of the channel

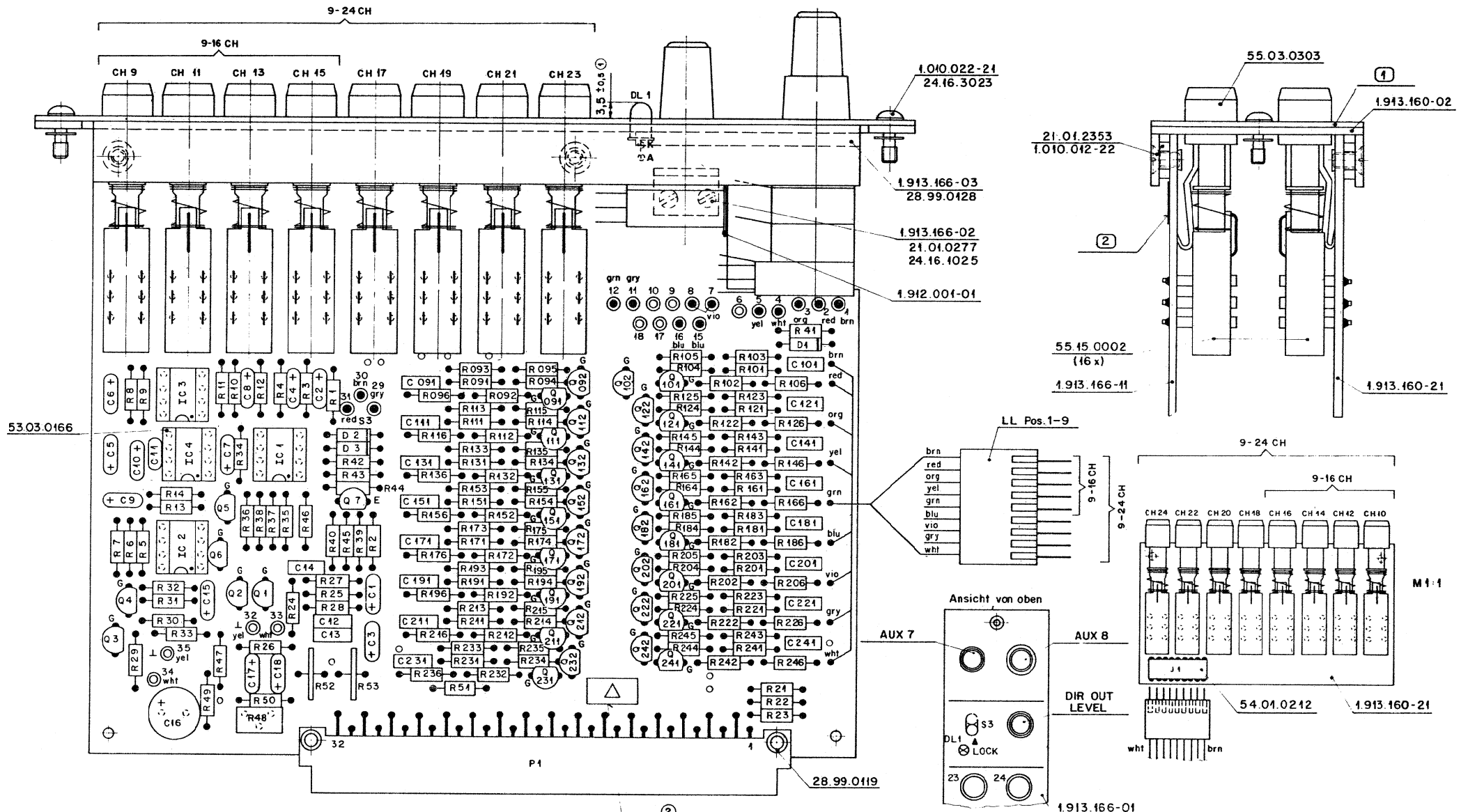

VALID FOR	NR. UNIT	NR. PL	(1)	(2)
9-16 CH	1.913.162-00	1.913.165-00	1.913.162-01	1.913.162-04
9-24 CH	1.913.166-00	1.913.166-00	1.913.166-01	1.913.166-04

Norm-Nr.:	Güte:	Änderung:	28.2.86 <i>De. W. W.</i>
Werkstoff:	Oberrichts- Beh.:		
DIN-Bez.:	Freimasstoleranz:	Ausgabe:	6.3.84 A.Ho <i>W. W.</i>
Abmessung:	Maßstab:		
Zugehörige Unterlagen:	+	1:1; 2:1	Gez. Gepr. Ges. Index
PL, LL, KL	Ersatz für:	Ersetzt durch:	Kopie für:
STUDDER REGENSDORF ZÜRICH		Benennung: SEL+DIR.FUNCTION ESE 9-24 CH	
Nummer:		1.913.166-00	

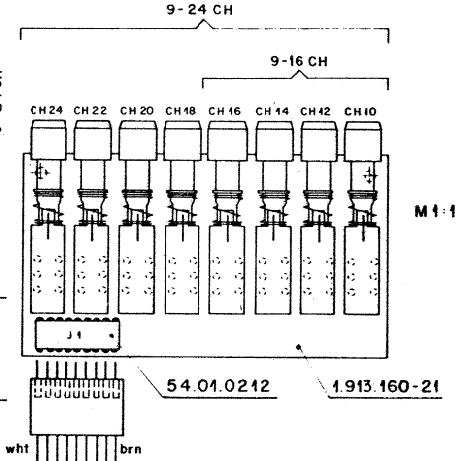
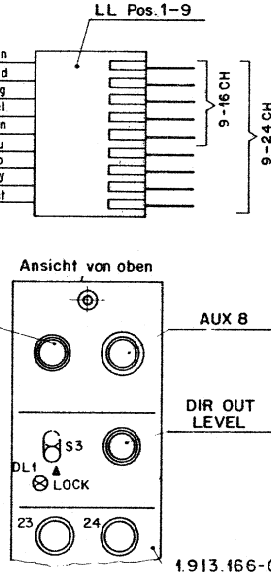
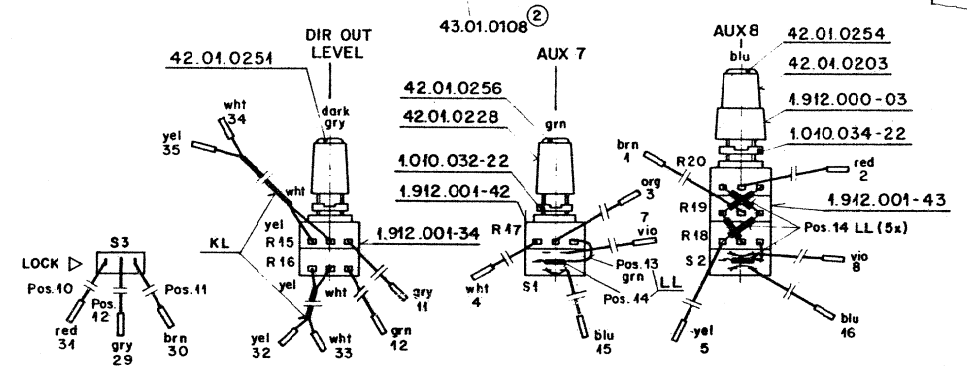

53.03.0166

9-24 CH

9-16 CH

CH 9 CH 11 CH 13 CH 15 CH 17 CH 19 CH 21 CH 23

1.010.022-21
24.16.3023

55.03.0303

1.913.160-02

21.01.2353
1.010.042-22

1.913.166-03
28.99.0428

1.913.166-02
21.01.0277
24.16.1025

1.912.001-01

55.45.0002
(16 x)

1.913.166-11

1.913.160-21

LL Pos. 1-9

9-24 CH

9-16 CH

M 1:1

Ansicht von oben

AUX 7

AUX 8

DIR OUT LEVEL

1.913.166-01

28.99.0419

P1

LOCK

Pos. 10

red 34

gry 29

Pos. 11

brn 30

wht 32

Pos. 12

wht 33

grn 12

Pos. 13

wht 33

grn 12

Pos. 14

wht 34

dark gry

Pos. 15

wht 34

dark gry

Pos. 16

wht 34

dark gry

Pos. 17

wht 34

dark gry

Pos. 18

wht 34

dark gry

Pos. 19

wht 34

dark gry

Pos. 20

wht 34

dark gry

Pos. 21

wht 34

dark gry

Pos. 22

wht 34

dark gry

Pos. 23

wht 34

dark gry

Pos. 24

wht 34

dark gry

Pos. 25

wht 34

dark gry

Pos. 26

wht 34

dark gry

Pos. 27

wht 34

dark gry

Pos. 28

wht 34

dark gry

Pos. 29

wht 34

dark gry

Pos. 30

wht 34

dark gry

Pos. 31

wht 34

dark gry

Pos. 32

wht 34

dark gry

Pos. 33

wht 34

dark gry

Pos. 34

wht 34

dark gry

Ae.-Index C1 Ae.-Datum 03.02.86
 Kopieausgabe 14.14 Uhr am 24.03.86

Visum WY

Ae.	Nummer	Titel	Remerkungen
C1	1.913.166.00	9-24CH.Sel.+ direct function	

Ind.	Pos.Nr.	Teil Nr.	Wert (Menge)	Bezeichnung	Hersteller
CU	C.....1	59.26.0680	68 uF	SAL	
CU	C.....2	59.26.0680	68 uF	SAL	
CU	C.....3	59.26.0680	68 uF	SAL	
CU	C.....4	59.26.0680	68 uF	SAL	
CU	C.....5	59.26.0680	68 uF	SAL	
CU	C.....6	59.26.0680	68 uF	SAL	
CU	C.....7	59.26.0680	68 uF	SAL	
CU	C.....8	59.26.0680	68 uF	SAL	
CU	C.....9	59.26.0680	68 uF	SAL	
CU	C.....10	59.26.0680	68 uF	SAL	
CU	C.....11	59.34.2220	22 pF	CEK	
CU	C.....12	59.06.0223	22 nF	PE	
CU	C.....13	59.06.0223	22 nF	PE	
CU	C.....14	59.06.0223	22 nF	PE	
CU	C.....15	59.26.0680	68 uF	SAL	
CU	C.....16	59.22.4101	100 uF	EL	
CU	C.....17	59.26.2100	10 uF	SAL	
CU	C.....18	59.26.2100	10 uF	SAL	
CU	C...xx1	59.06.0223	22 nF	PE	see note 1)
CU	C.....1	50.04.0125	1N4448		any
CU	C.....2	50.04.0125	1N4448		any
CU	C.....3	50.04.0125	1N4448		any
CU	CL.....1	50.04.2111	MV5753	red	GI,HP
CU	IC.....1	50.09.0105	NE5532N	dual op.amp.	Sig,Ex,Pa
CU	IC.....2	50.09.0105	NE5532N	dual op.amp.	Sig,Ex,Pa
CU	IC.....3	50.09.0105	NE5532N	dual op.amp.	Sig,Ex,Pa
CU	IC.....4	50.05.0243	NE5534N	single op.amp.	Ti,Sig,Pa
CU	P.....1	54.01.0359	2*16pin	euroconnector	Pu
CU	Q.....1	50.03.0350	J 112	N-JFET	NS,Mot,Six
CU	Q.....2	50.03.0350	J 112	N-JFET	NS,Mot,Six
CU	Q.....3	50.03.0350	J 112	N-JFET	NS,Mot,Six
CU	Q.....4	50.03.0350	J 112	N-JFET	NS,Mot,Six
CU	Q.....5	50.03.0350	J 112	N-JFET	NS,Mot,Six
CU	Q.....6	50.03.0350	J 112	N-JFET	NS,Mot,Six
CU	Q.....7	50.03.0515	BC 307	PNP IC>100mA, B>100	any
CU	Q...xx1	50.03.0350	J 112	N-JFET see note 1)	NS,Mot,Six
CU	Q...xx2	50.03.0350	J 112	N-JFET see note 1)	NS,Mot,Six
CU	R.....1	57.11.4333	33 kOhm		
CU	R.....2	57.11.4333	33 kOhm		
CU	R.....3	57.11.4104	100 kOhm		
CU	R.....4	57.11.4104	100 kOhm		
CU	R.....5	57.11.3471	470 Ohm	1%	
CU	R.....6	57.11.3471	470 Ohm	1%	

Ae.-Index 01 Ae.-Datum C3.02.86
 Kopieausgabe 14.14 Uhr am 24.03.86

Visum WY

Ind.	Pcs.-Nr.	Teil Nr.	Wert (Menge)	Bezeichnung	Hersteller
CO	R.....7	57.11.3471	470 Ohm		
CO	R.....8	57.11.4222	2.2 kOhm	2%	
CO	R.....9	57.11.4222	2.2 kOhm	2%	
CO	R.....10	57.11.4222	2.2 kOhm	2%	
CO	R.....11	57.11.4222	2.2 kOhm	2%	
CO	R.....12	57.11.4104	100 kOhm		
CO	R.....13	57.11.4222	2.2 kOhm	2%	
CO	R.....14	57.11.4222	2.2 kOhm	2%	
CO	R.....15	1.912.001.34	10 kOhm	pos.log.	potm. R15,R16
CO	R.....16		10 kOhm	pos.log.	
CO	R.....17	1.912.001.42	10 kOhm	pos.log.	potm. and switch S1
CO	R.....18	1.912.001.43	4.7 kOhm	pos.log.	potm.R18,R19,R20 and switch S2
CO	R.....19		10 kOhm	pos.log.	
CO	R.....20		10 kOhm	neg.log.	
CO	R.....21	57.11.4332	3.3 kOhm	2%	
CO	R.....22	57.11.4332	3.3 kOhm	2%	
CO	R.....23	57.11.4332	3.3 kOhm	2%	
CI	R.....24	57.11.4472	4.7 kOhm		
CO	R.....25	57.11.4104	100 kOhm		
CO	R.....26	57.11.4104	100 kOhm		
CO	R.....27	57.11.4104	100 kOhm		
CO	R.....28	57.11.4105	1 MOhm		
CO	R.....29	57.11.4472	4.7 kOhm		
CO	R.....30	57.11.4104	100 kOhm		
CO	R.....31	57.11.4104	100 kOhm		
CO	R.....32	57.11.4104	100 kOhm		
CO	R.....33	57.11.4334	330 kOhm		
CO	R.....34	57.11.4153	15 kOhm		
CO	R.....35	57.11.4104	100 kOhm		
CO	R.....36	57.11.4104	100 kOhm		
CO	R.....37	57.11.4104	100 kOhm		
CO	R.....38	57.11.4105	1 MOhm		
CO	R.....39	57.11.4334	330 kOhm		
CO	R.....40	57.11.4332	3.3 kOhm		
CO	R.....41	57.11.4391	390 Ohm		
CO	R.....42	57.11.4334	330 kOhm		
CO	R.....43	57.11.4334	330 kOhm		
CO	R.....44	57.11.4334	330 kOhm		
CO	R.....45	57.11.4332	3.3 kOhm		
CO	R.....46	57.11.4332	3.3 kOhm		
CO	R.....47	57.11.4472	4.7 kOhm		
CO	R.....48	58.01.9203	20 kOhm	trimming resistor	
CO	R.....49	57.11.4104	100 kOhm		
CO	R.....50	57.11.4330	33 Ohm		
CO	R.....51	57.11.4102	1 kOhm		
CO	R.....52	57.99.0209	5.6 Ohm	PTC	Philips Nr.2322 662 91005
CO	R.....53	57.99.0209	5.6 Ohm	PTC	Philips Nr.2322 662 91005
CO	R.....xx1	57.11.4332	3.3 kOhm		see note 1)
CO	R.....xx2	57.11.4104	100 kOhm		see note 1)
CO	R.....xx3	57.11.4105	1 MOhm		see note 1)
CO	R.....xx4	57.11.4104	100 kOhm		see note 1)
CO	R.....xx5	57.11.4104	100 kOhm		see note 1)
CO	R.....xx6	57.11.4332	3.3 kOhm		see note 1)

Ae.-Index 01 Ae.-Datum 03.02.86
 Kopieausgabe 14.14 Uhr am 24.03.86

Visum WY

Ind.	Pos.Nr.	Teil Nr.	Wert (Menge)	Bezeichnung	Hersteller
CO	S...x1	55.15.0002	2*U	see note 1)	Schadow ITT
CO	S.....3	55.01.0110	toggle	switch 1:on-off-on	Dialight, C&K

CER =ceramic, PE=polyester, SAL=solid aluminium lacquard

MANUFACTURER: Bu=Burdny, C&K=C&K Components Inc, GI=General Instrument
 HP=Hewlett Packard, IIT=Intermetall, Mot=Motorola,
 NS=National Semiconductors, Ra=Raytheon, Sig=Signetics,
 Six=Siliconix, TI=Texas Instruments, Ex=Exar

 * This positions list is also valid for 1.913.162.00 *
 * Diese Positionsliste ist auch für 1.913.162.00 gültig *
 * 9-16CH.SEL. + DIRECT FUNCTION *

note 1): xx means the number of the channel
 xx steht für die Kanalnummer
 1.913.162.00 bestückt sind Kanal 9-16 (8x)
 1.913.166.00 bestückt sind Kanal 9-24 (16x)

Ende der Positions Liste.

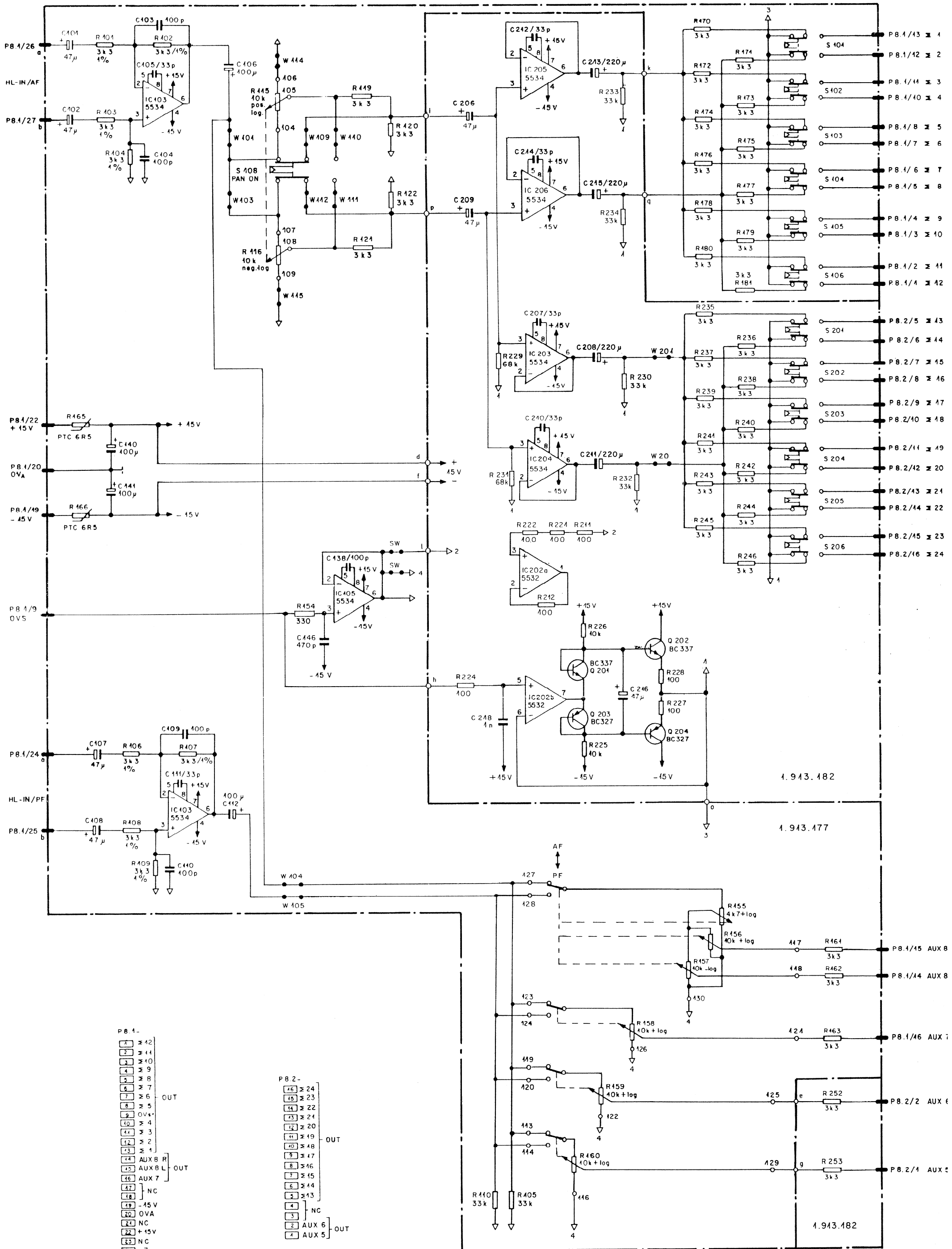

- PB. 1-
- 1 ≙ 12
 - 2 ≙ 14
 - 3 ≙ 10
 - 4 ≙ 9
 - 5 ≙ 8
 - 6 ≙ 7
 - 7 ≙ 6
 - 8 ≙ 5
 - 9 OVA
 - 10 ≙ 4
 - 11 ≙ 3
 - 12 ≙ 2
 - 13 ≙ 1
 - 14 AUX B R
 - 15 AUX B L
 - 16 AUX 7
 - 17 } NC
 - 18 } -15 V
 - 19 OVA
 - 20 NC
 - 21 +15 V
 - 22 NC
 - 23 } a
 - 24 } HL-IN (PF)
 - 25 } b
 - 26 } a
 - 27 } HL-IN (AF)
 - 28 } b
 - 29 } NC
 - 30 } NC
 - 31 } NC
 - 32 } NC

- PB. 2-
- 1 ≙ 24
 - 2 ≙ 23
 - 3 ≙ 22
 - 4 ≙ 21
 - 5 ≙ 20
 - 6 ≙ 19
 - 7 ≙ 18
 - 8 ≙ 17
 - 9 ≙ 16
 - 10 ≙ 15
 - 11 ≙ 14
 - 12 ≙ 13
 - 13 } NC
 - 14 } NC
 - 15 } NC
 - 16 } NC
 - 17 } NC
 - 18 } NC
 - 19 } NC
 - 20 } NC
 - 21 } NC
 - 22 } NC
 - 23 } NC
 - 24 } NC

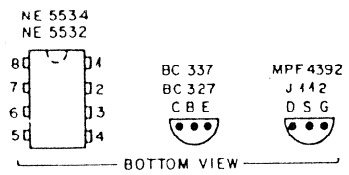

27 6.86	SC 1.913.177
STUDEF REGENDORF ZURICH	24 CH SEL. MONO

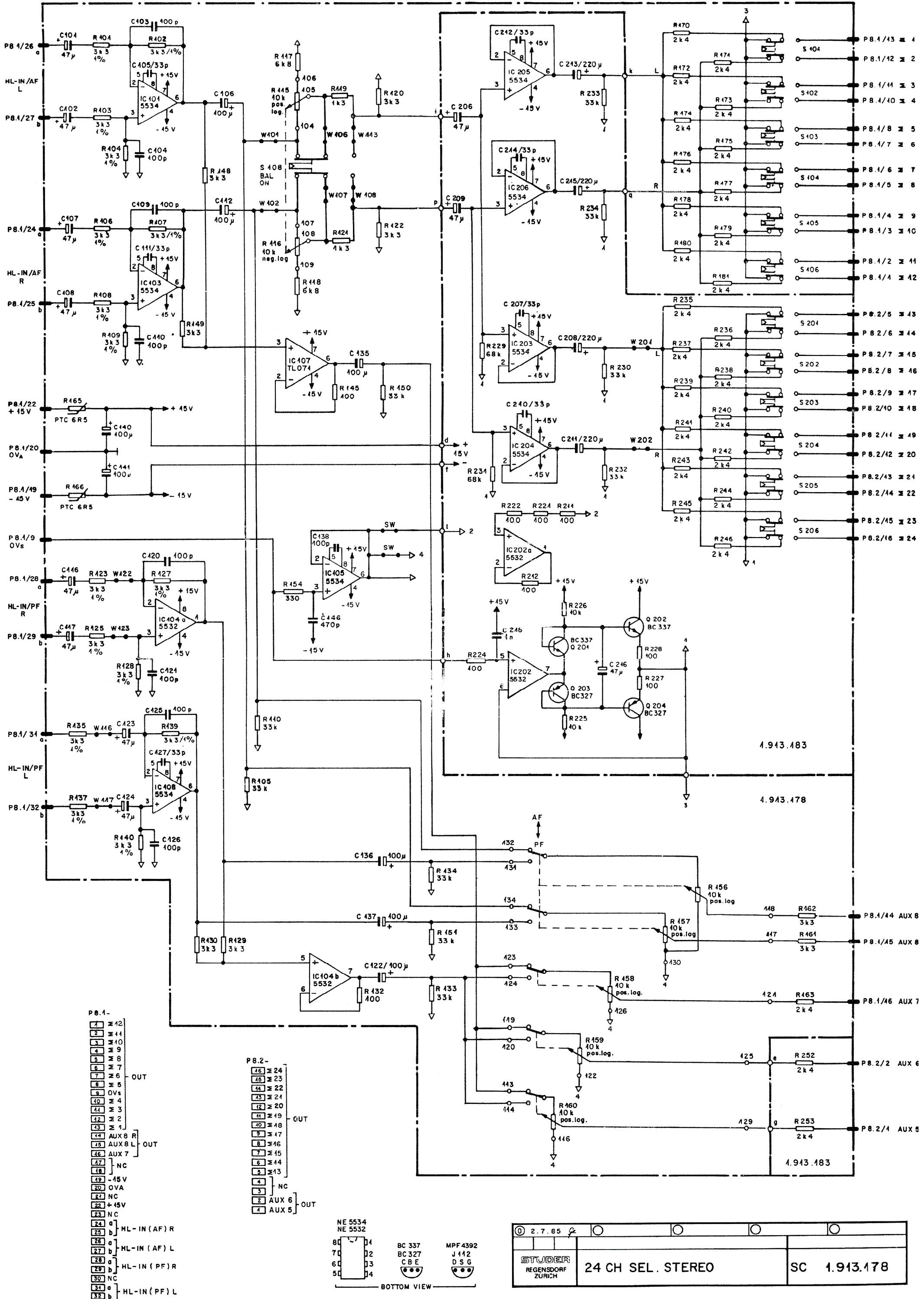

- PB.1-
 1 ≙ 42
 2 ≙ 41
 3 ≙ 40
 4 ≙ 39
 5 ≙ 38
 6 ≙ 37
 7 ≙ 36
 8 ≙ 35
 9 ≙ 34
 10 ≙ 33
 11 ≙ 32
 12 ≙ 31
 13 ≙ 30
 14 ≙ 29
 15 ≙ 28
 16 ≙ 27
 17 ≙ 26
 18 ≙ 25
 19 ≙ 24
 20 ≙ 23
 21 ≙ 22
 22 ≙ 21
 23 ≙ 20
 24 ≙ 19
 25 ≙ 18
 26 ≙ 17
 27 ≙ 16
 28 ≙ 15
 29 ≙ 14
 30 ≙ 13
 31 ≙ 12
 32 ≙ 11
 33 ≙ 10
 34 ≙ 9
 35 ≙ 8
 36 ≙ 7
 37 ≙ 6
 38 ≙ 5
 39 ≙ 4
 40 ≙ 3
 41 ≙ 2
 42 ≙ 1

- PB.2-
 46 ≙ 24
 48 ≙ 23
 44 ≙ 22
 43 ≙ 21
 42 ≙ 20
 41 ≙ 19
 40 ≙ 18
 39 ≙ 17
 38 ≙ 16
 37 ≙ 15
 36 ≙ 14
 35 ≙ 13
 34 ≙ 12
 33 ≙ 11
 32 ≙ 10
 31 ≙ 9
 30 ≙ 8
 29 ≙ 7
 28 ≙ 6
 27 ≙ 5
 26 ≙ 4
 25 ≙ 3
 24 ≙ 2
 23 ≙ 1

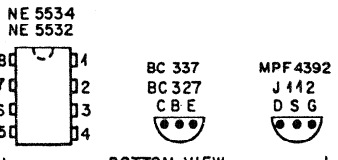

2.7.85	STUDER REGENSDORF ZÜRICH	24 CH SEL. STEREO	SC 1.913.178
--------	--------------------------------	-------------------	--------------

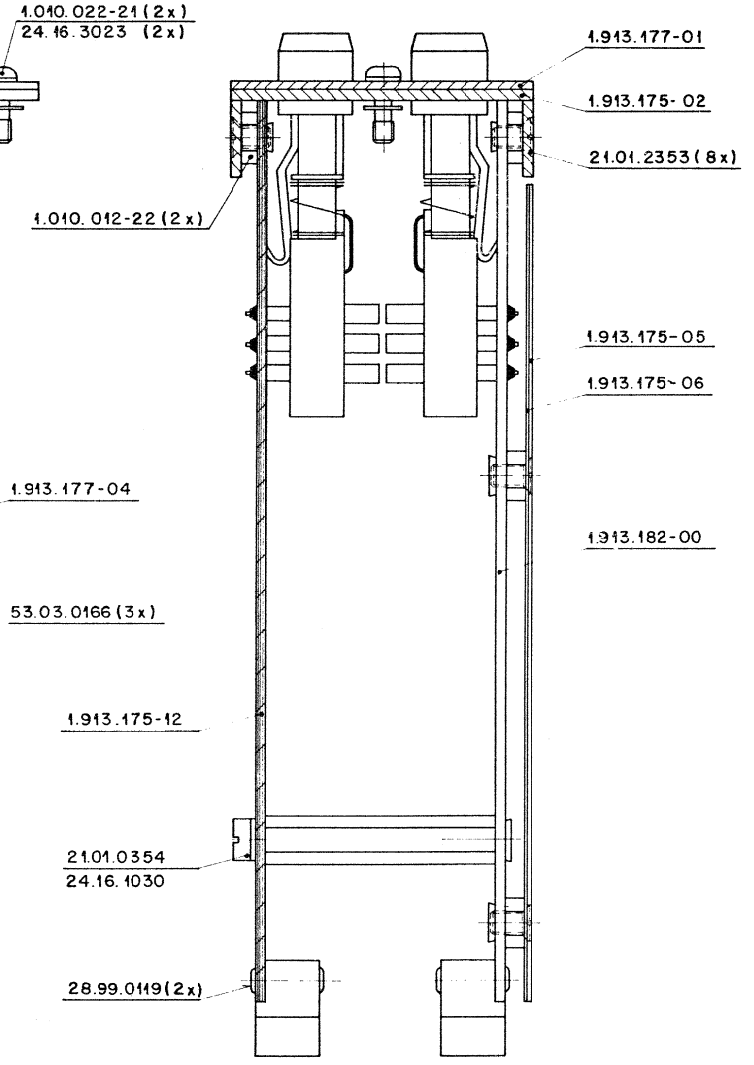
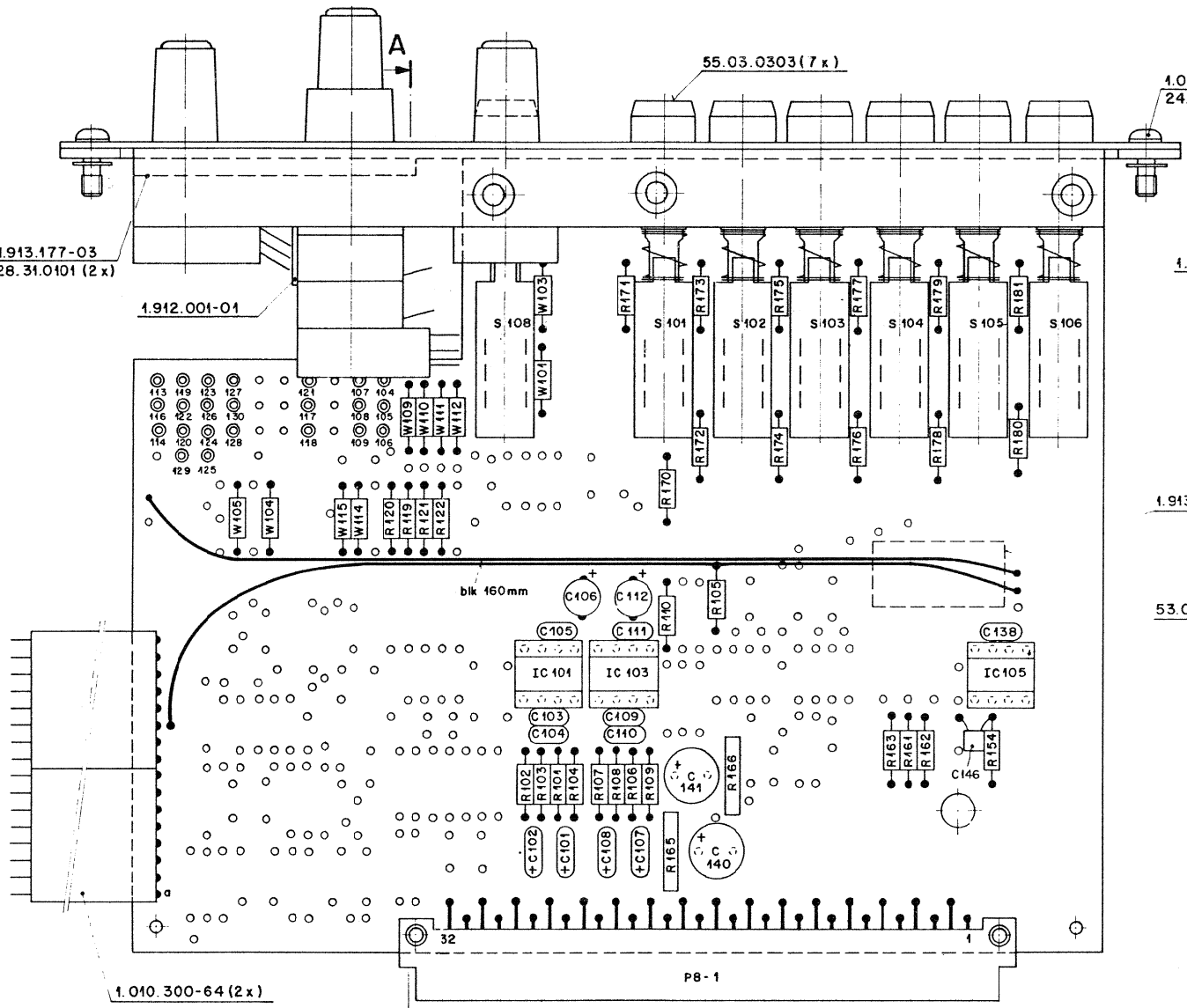

Schnitt A-A

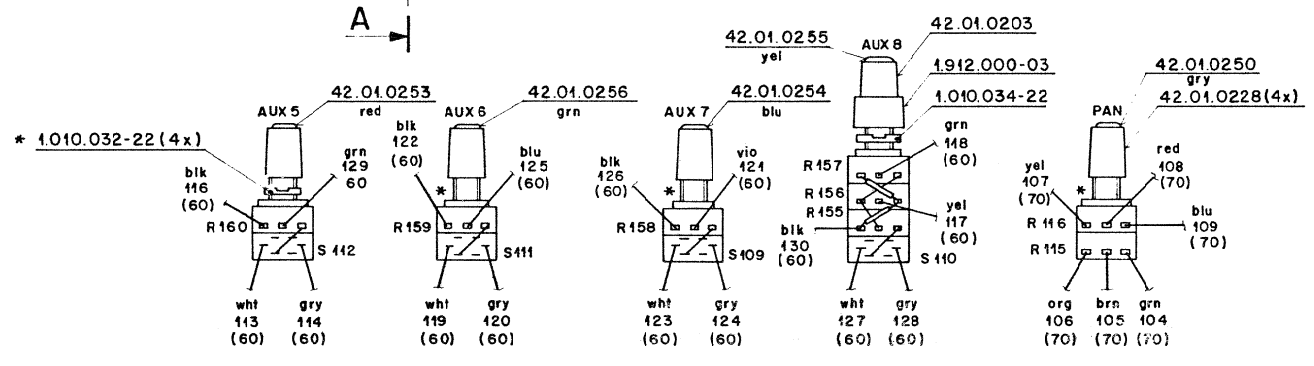

Werkstoff	Norm-Nr.:	Gute:	Änderung	③
	DIN-Bez.:	Oberfläche		②
	Abmessung:	Beh.:		①
Zugehörige Unterlagen:	PL	Freimasstoleranz:	Maßstab:	13.3.86 A Ho
		+	4:1; 2:1	PL
Ersatz für:		Ersetzt durch:		Kopie für:
STUDER REGENSDORF ZÜRICH		Benennung: 24-CH SEL. MONO		Nummer: 1.913.177-00

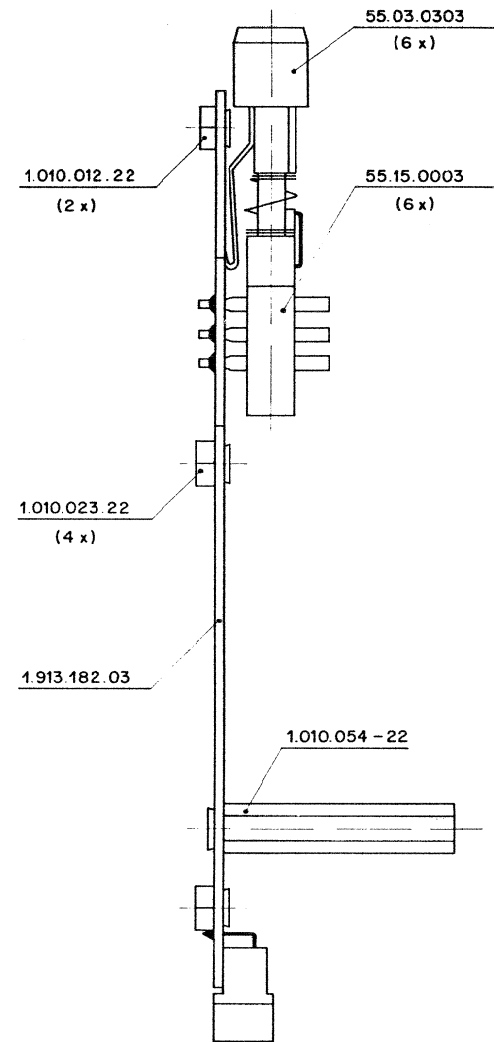
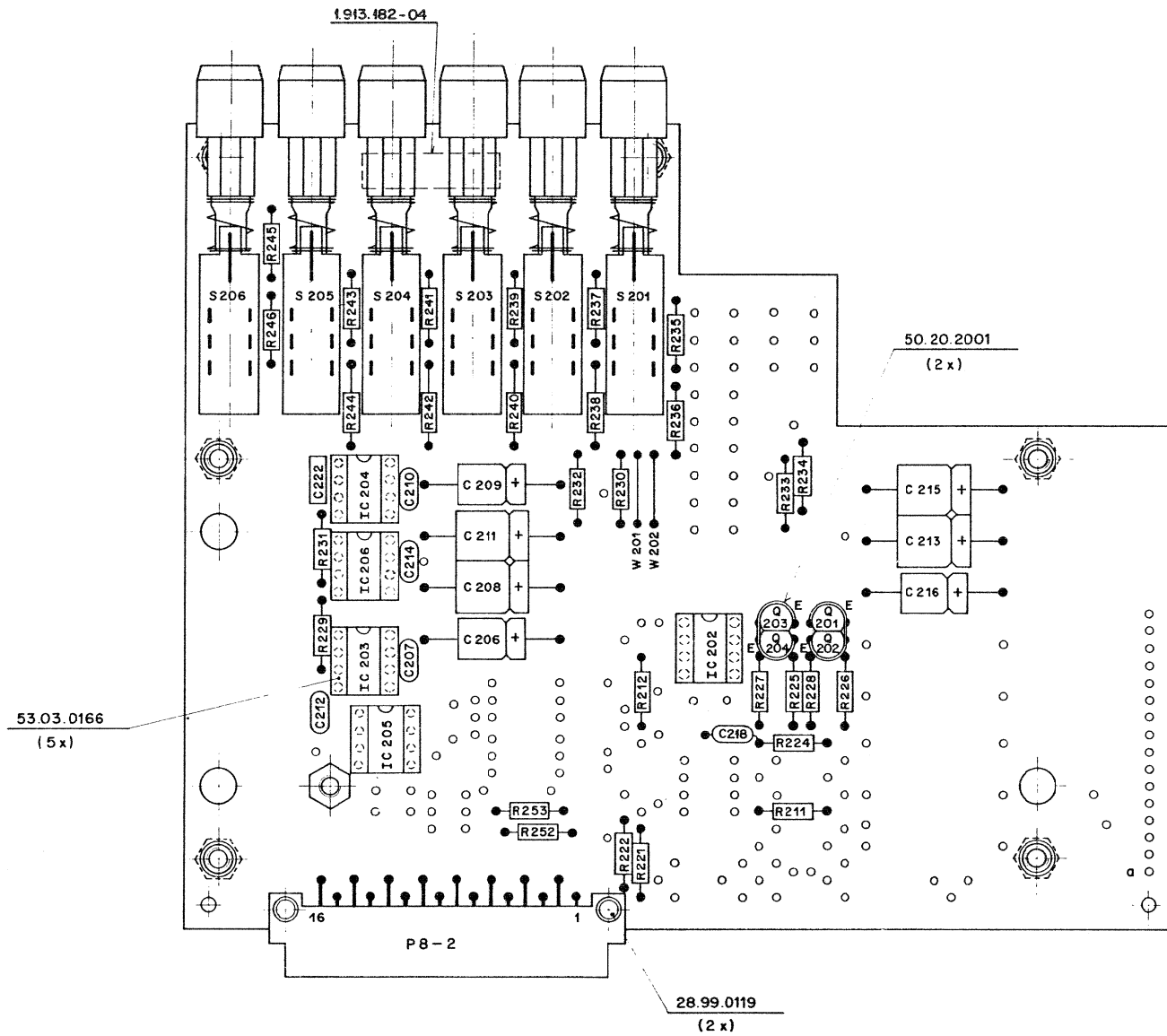

Werkstoff	Norm-Nr.:	Güte.	Änderung	③
	DIN-Bez.:	Beh.		②
Abmessung:			①	
Zugehörige Unterlagen:	Freimasstoleranz:	Maßstab:	Ausgabe	①
PL 1.913.177-00	±	2:1	Datum	Gez. Gepr. Ges. Index
Ersetzt für:	Ersetzt durch:	Kopie für:		
STUDER REGENSDORF ZÜRICH	Benennung: 6 SWITCH MONO			Nummer: 1.913.182-00

Ae.-Index CU Ae.-Datum 03.05.85
 Kopieausgabe 16.44 Uhr am 15.04.86

Visum TA

Ae. Nummer Titel Bemerkungen

 GO 1.913.177.00 24-CH-SEL. MOND

Ind.	Pcs.Nr.	Teil Nr.	Wert (Menge)	Bezeichnung	Hersteller

00	C...101	59.26.0470	47 uF	20% 6.3V	SAL
00	C...102	59.26.0470	47 uF	20% 6.3V	SAL
00	C...103	59.34.4101	100 pF		CE
00	C...104	59.34.4101	100 pF		CE
00	C...105	59.34.2330	33 pF		CE
00	C...106	59.22.3101	100 uF	-20% 10V	EL
00	C...107	59.26.0470	47 uF	20% 6.3V	SAL
00	C...108	59.26.0470	47 uF	20% 6.3V	SAL
00	C...109	59.34.4101	100 pF		CE
00	C...110	59.34.4101	100 pF		CE
00	C...111	59.34.2330	33 pF		CE
00	C...112	59.22.3101	100 uF	-20% 10V	EL
00	C...113		not used		
00	C...114		not used		
00	C...115		not used		
00	C...116		not used		
00	C...117		not used		
00	C...118		not used		
00	C...119		not used		
00	C...120		not used		
00	C...121		not used		
00	C...122		not used		
00	C...123		not used		
00	C...124		not used		
00	C...125		not used		
00	C...126		not used		
00	C...127		not used		
00	C...128		not used		
00	C...129		not used		
00	C...130		not used		
00	C...131		not used		
00	C...132		not used		
00	C...133		not used		
00	C...134		not used		
00	C...135		not used		
00	C...136		not used		
00	C...137		not used		
00	C...138	59.34.4101	100 pF		CE
00	C...139		not exist		
00	C...140	59.22.4101	100 uF	-20% 16V	EL
00	C...141	59.22.4101	100 uF	-20% 16V	EL
00	C...142		not used		
00	C...143		not used		
00	C...144		not used		
00	C...145		not used		
02	C...146	59.34.5471	470 pF		CE
00	IC...101	03.05.0243	NE5534N	single op. amp.	Sig,Ra
00	IC...102		not used		

Ae.-Index 00 Ae.-Datum 03.05.85
 Kopieausgabe 16.44 Uhr am 15.04.86

Visum 7A

Ind.	Pos.Nr.	Teil Nr.	Wert (Menge)	Bezeichnung	Hersteller
00	IC..103	50.05.0243	NE5534N	single op. amp.	Sig,Ra
00	IC..104		not used		
00	IC..105	50.05.0243	NE5534N	single op. amp.	Sig,Ra
00	IC..106		not used		
00	IC..107		not used		
00	IC..108		not used		
00	MP....1	53.03.0166	3 pcs	IC-socket 8 pin	
00	P...8.1	54.01.0359	2*16pin	euroconnector	Bu
00	R...101	57.11.3332	3.3 kOhm	1% 0.25W	
00	R...102	57.11.3332	3.3 kOhm	1% 0.25W	
00	R...103	57.11.3332	3.3 kOhm	1% 0.25W	
00	R...104	57.11.3332	3.3 kOhm	1% 0.25W	
00	R...105	57.11.4333	33 kOhm	5% 0.25W	
00	R...106	57.11.3332	3.3 kOhm	1% 0.25W	
00	R...107	57.11.3332	3.3 kOhm	1% 0.25W	
00	R...108	57.11.3332	3.3 kOhm	1% 0.25W	
00	R...109	57.11.3332	3.3 kOhm	1% 0.25W	
00	R...110	57.11.4333	33 kOhm	5% 0.25W	
00	R...111		not used		
00	R...112		not used		
00	R...113		not used		
00	R...114		not used		
00	R...115	1.912.001.35	10 kOhm	pos.log. combined with R116 St	
00	R...116		10 kOhm	neg.log. see R115	
00	R...117		not used		
00	R...118		not used		
00	R...119	57.11.4332	3.3 kOhm	5% 0.25W	
00	R...120	57.11.4332	3.3 kOhm	5% 0.25W	
00	R...121	57.11.4332	3.3 kOhm	5% 0.25W	
00	R...122	57.11.4332	3.3 kOhm	5% 0.25W	
00	R...123		not used		
00	R...124		not used		
00	R...125		not used		
00	R...126		not used		
00	R...127		not used		
00	R...128		not used		
00	R...129		not used		
00	R...130		not used		
00	R...131		not used		
00	R...132		not used		
00	R...133		not used		
00	R...134		not used		
00	R...135		not used		
00	R...136		not used		
00	R...137		not used		
00	R...138		not used		
00	R...139		not used		
00	R...140		not used		
00	R...141		not used		
00	R...142		not used		
00	R...143		not used		

Ae.-Index 00 Ae.-Datum 03.05.85
 Kopieausgabe 16.44 Uhr am 15.04.86

Visum TA

Ind.	Pos.Nr.	Teil Nr.	Wert(Menge)	Bezeichnung	Hersteller
00	R...144		not used		
00	R...145		not used		
00	R...146		not used		
00	R...147		not used		
00	R...148		not used		
00	R...149		not used		
00	R...150		not used		
00	R...151		not used		
00	R...152		not used		
00	R...153		not used		
00	R...154	57.11.4331	330 Ohm	5% 0.25W	
00	R...155	1.912.001.43	4.7 kOhm	10% pos.log.	combined with R156/R157 St
00	R...156		10 kOhm	10% pos.log.	see R155
00	R...157		10 kOhm	10% neg.log.	see R155
00	R...158	1.912.001.42	1C kOhm	10% pos.log.	variable resistor St
00	R...159	1.912.001.42	10 kOhm	10% pos.log.	variable resistor St
00	R...160	1.912.001.42	10 kOhm	10% pos.log.	variable resistor St
00	R...161	57.11.4332	3.3 kOhm	5% 0.25W	
00	R...162	57.11.4332	3.3 kOhm	5% 0.25W	
00	R...163	57.11.4332	3.3 kOhm	5% 0.25W	
00	R...164		not used		
00	R...165	57.92.1271	6.5 Ohm	I = 270mA PTC	Philips Nr.2322 662 12711
00	R...166	57.92.1271	6.5 Ohm	I = 270mA PTC	Philips Nr.2322 662 12711
00	R...167		not used		
00	R...168		not used		
00	R...169		not used		
00	R...170	57.11.4332	3.3 kOhm	2% 0.25W	
00	R...171	57.11.4332	3.3 kOhm	2% 0.25W	
00	R...172	57.11.4332	3.3 kOhm	2% 0.25W	
00	R...173	57.11.4332	3.3 kOhm	2% 0.25W	
00	R...174	57.11.4332	3.3 kOhm	2% 0.25W	
00	R...175	57.11.4332	3.3 kOhm	2% 0.25W	
00	R...176	57.11.4332	3.3 kOhm	2% 0.25W	
00	R...177	57.11.4332	3.3 kOhm	2% 0.25W	
00	R...178	57.11.4332	3.3 kOhm	2% 0.25W	
00	R...179	57.11.4332	3.3 kOhm	2% 0.25W	
00	R...180	57.11.4332	3.3 kOhm	2% 0.25W	
00	R...181	57.11.4332	3.3 kOhm	2% 0.25W	
00	R...182		not used		
00	R...183		not used		
00	R...184		not used		
00	R...185		not used		
00	S...101	55.15.0003	2*U	3u Au	button : red ITT
00	S...102	55.15.0003	2*U	3u Au	button : red ITT
00	S...103	55.15.0003	2*U	3u Au	button : red ITT
00	S...104	55.15.0003	2*U	3u Au	button : red ITT
00	S...105	55.15.0003	2*U	3u Au	button : red ITT

Ae.-Index 00 Ae.-Datum 03.05.85
 Kopieausgabe 16.44 Uhr am 15.04.86

Visum TA

Ind.	Pos.-Nr.	Teil Nr.	Wert (Menge)	Bezeichnung	Hersteller
00	S...106	55.15.0003	2*U	3u Au button : red	ITT
00	S...107		not used		
00	S...108	55.15.0003	2*U	3u Au button : red	ITT
00	W...101				
00	W...102		not used		
00	W...103				
00	W...104				
00	W...105				
00	W...106		not used		
00	W...107		not used		
00	W...108		not used		
00	W...109				
00	W...110				
00	W...111				
00	W...112				
00	W...113		not used		
00	W...114				
00	W...115				
00	W...116		not used		
00	W...117		not used		
00	W...118		not used		
00	W...119		not used		
00	W...120	1.010.300.64	8-wire	flatcable	40 mm
00	W...121	1.010.300.64	8-wire	flatcable	40 mm
00	W...122		not used		
00	W...123		not used		
00	W...124		not used		
00	W...125		not used		
00	C...201		not used		
00	C...202		not used		
00	C...203		not used		
00	C...204		not used		
00	C...205		not used		
00	C...206	59.25.3470	47 uF	-20% 16V	EL
00	C...207	59.34.2330	33 pF		CE
00	C...208	59.25.1221	220 uF	-20% 6.3V	EL
00	C...209	59.25.3470	47 uF	-20% 16V	EL
00	C...210	59.34.2330	33 pF		CE
00	C...211	59.25.1221	220 uF	-20% 6.3V	EL
00	C...212	59.34.2330	33 pF		CE
00	C...213	59.25.1221	220 uF	-20% 6.3V	EL
00	C...214	59.34.2330	33 pF		CE
00	C...215	59.25.1221	220 uF	-20% 6.3V	EL
00	C...216	59.25.3470	47 uF	-20% 16V	EL
00	C...217		not used		
01	C...218	59.32.4102	1 nF		CE
00	C...219		not used		
00	C...220		not used		
00	C...221		not used		
00	C...222	59.06.0223	22 nF		PE
00	C...223		not used		
00	C...224		not used		

Ae.-Index 00 Ae.-Datum 03.05.85
 Kopieausgabe 16.44 Uhr am 15.04.86

Visum TA

Ind.	Pos.Nr.	Teil Nr.	Wert (Menge)	Bezeichnung	Hersteller
00	IC..201		not used		
00	IC..202	50.09.0105	NE5532	dual op. amp.	Sig,Ex,Ra
00	IC..203	50.05.0243	NE5534N	single op. amp.	Sig,Ra
00	IC..204	50.05.0243	NE5534N	single op. amp.	Sig,Ra
00	IC..205	50.05.0243	NE5534N	single op. amp.	Sig,Ra
00	IC..206	50.05.0243	NE5534N	single op. amp.	Sig,Ra
00	MP....1	53.03.0166	5 pcs	IC-socket 8 pin	
00	MP....2	50.20.2001	2 pcs	CLIP ; 2 * TD 92	St
00	P...8.2	54.11.2007	2*8 pin	euroconnector	Bu
00	C...201	50.03.0516	BC 337	NPN matched with Q 202	Sie
00	Q...202	50.03.0516	BC 337	NPN	Sie
00	C...203	50.03.0625	BC 327	PNP matched with Q 204	Sie
00	C...204	50.03.0625	BC 327	PNP	Sie
00	R...201		not used		
00	R...202		not used		
00	R...203		not used		
00	R...204		not used		
00	R...205		not used		
00	R...206		not used		
00	R...207		not used		
00	R...208		not used		
00	R...209		not used		
00	R...210		not used		
00	R...211	57.11.4101	100 Ohm	2% 0.25W	
00	R...212	57.11.4101	100 Ohm	2% 0.25W	
00	R...213		not used		
00	R...214		not used		
00	R...215		not used		
00	R...216		not used		
00	R...217		not used		
00	R...218		not used		
00	R...219		not used		
00	R...220		not used		
00	R...221	57.11.4101	100 Ohm	5% 0.25W	
00	R...222	57.11.4101	100 Ohm	5% 0.25W	
00	R...223		not used		
00	R...224	57.11.4101	100 Ohm	5% 0.25W	
00	R...225	57.11.4103	10 kOhm	5% 0.25W	
00	R...226	57.11.4103	10 kOhm	5% 0.25W	
00	R...227	57.11.4101	100 Ohm	5% 0.25W	
00	R...228	57.11.4101	100 Ohm	5% 0.25W	
00	R...229	57.11.4683	68 kOhm	5% 0.25W	
00	R...230	57.11.4333	33 kOhm	5% 0.25W	
00	R...231	57.11.4683	68 kOhm	5% 0.25W	
00	R...232	57.11.4333	33 kOhm	5% 0.25W	
00	R...233	57.11.4333	33 kOhm	5% 0.25W	
00	R...234	57.11.4333	33 kOhm	5% 0.25W	
00	R...235	57.11.4332	3.3 kOhm	2% 0.25W	
00	R...236	57.11.4332	3.3 kOhm	2% 0.25W	

Ae.-Index 00 Ae.-Datum 03.05.85
 Kopieausgabe 16.44 Uhr am 15.04.86

Visum TA

Ind.	Pos.Nr.	Teil Nr.	Wert (Menge)	Bezeichnung	Hersteller
00	R...237	57.11.4332	3.3 kOhm	2% 0.25W	
00	R...238	57.11.4332	3.3 kOhm	2% 0.25W	
00	R...239	57.11.4332	3.3 kOhm	2% 0.25W	
00	R...240	57.11.4332	3.3 kOhm	2% 0.25W	
00	R...241	57.11.4332	3.3 kOhm	2% 0.25W	
00	R...242	57.11.4332	3.3 kOhm	2% 0.25W	
00	R...243	57.11.4332	3.3 kOhm	2% 0.25W	
00	R...244	57.11.4332	3.3 kOhm	2% 0.25W	
00	R...245	57.11.4332	3.3 kOhm	2% 0.25W	
00	R...246	57.11.4332	3.3 kOhm	2% 0.25W	
00	R...247		not used		
00	R...248		not used		
00	R...249		not used		
00	R...250		not used		
00	R...251		not used		
00	R...252	57.11.4332	3.3 kOhm	5% 0.25W	
00	R...253	57.11.4332	3.3 kOhm	5% 0.25W	
00	S...201	55.15.0003	2*U	3u Au button : red	ITT
00	S...202	55.15.0003	2*U	3u Au button : red	ITT
00	S...203	55.15.0003	2*U	3u Au button : red	ITT
00	S...204	55.15.0003	2*U	3u Au button : red	ITT
00	S...205	55.15.0003	2*U	3u Au button : red	ITT
00	S...206	55.15.0003	2*U	3u Au button : red	ITT
00	W...201				
00	W...202				

CE=Ceramic, CF=Carbon Film, EL=Electrolytic, MF=Metal Film,
 PE=Polyester, PP=Polypropylen, PS=Polystyrol

MANUFACTURER: Bu=Burndy, Ex=Exar, Fc=Fairchild, GI=General Instrument
 HP=Hewlett Packard, ITT=Intermetall, Mot=Motorola, Nat=N
 (Matsushita), NS=National Semiconductors, Ph=Philips,
 Ra=Raytheon, Sig=Signetics, Six=Siliconix, St=Studer,
 TI=Texas Instrument

Ende der Positions Liste.

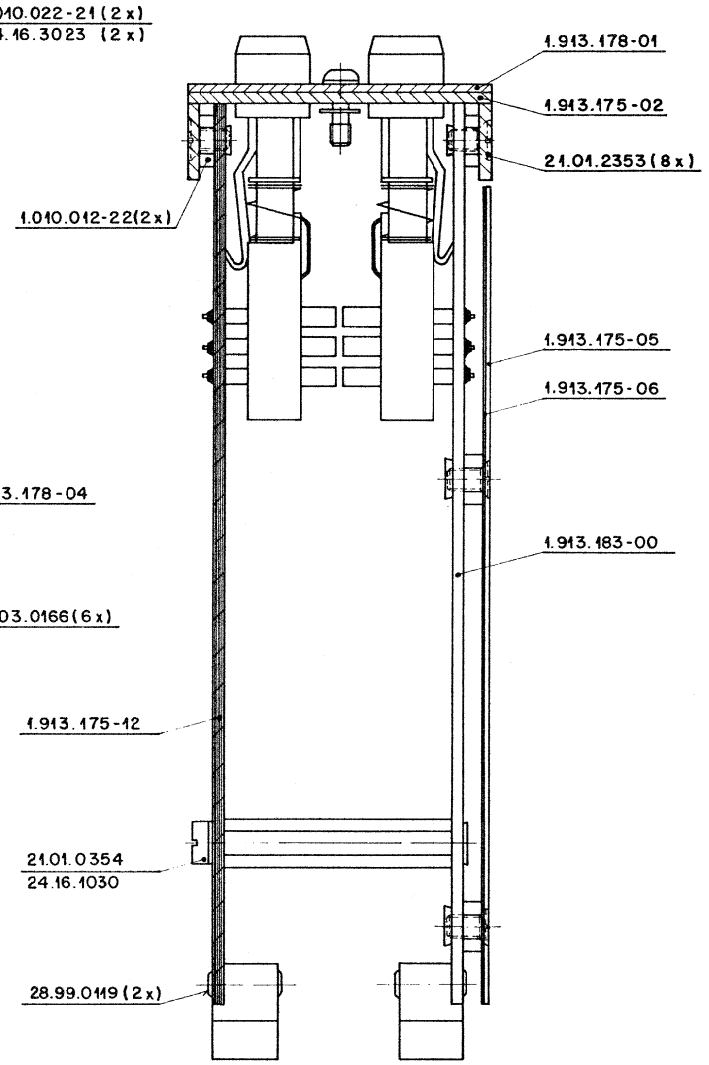
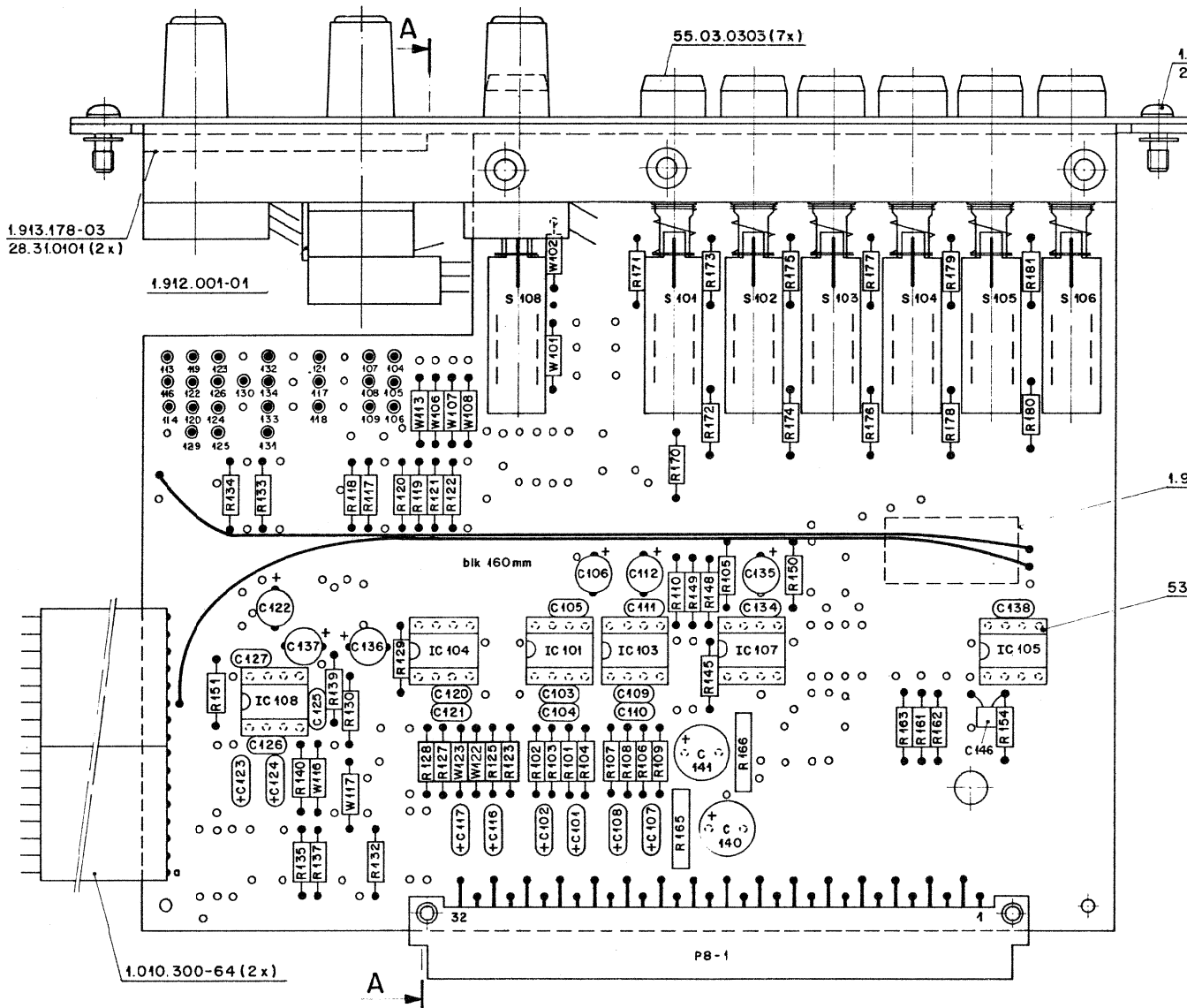

Schnitt A-A

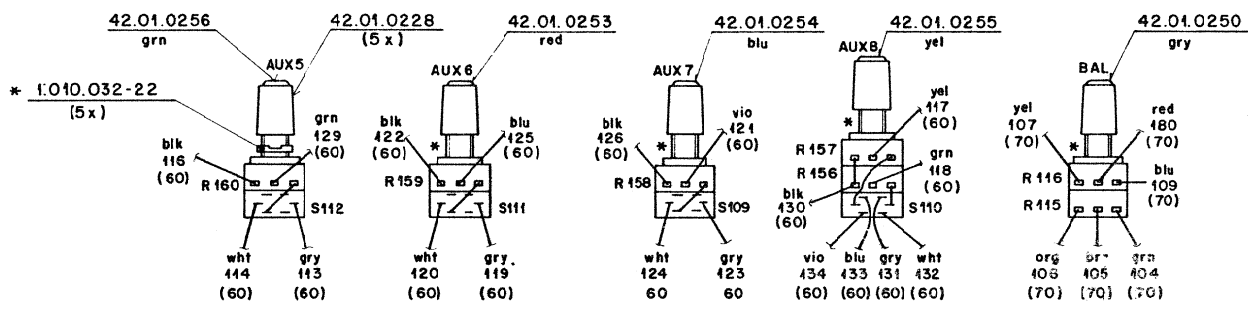

Norm-Nr.:	Güte:		Änderung
DIN-Bez.:	Oberfläche:		
Abmessung:	Beh.:		
Zugehörige Unterlagen:	Freimasstoleranz:	Maßstab:	12.3.86 A.Ho. <i>7/</i>
PL	+	1:4; 2:1	Ausgabe
Ersatz für:	Ersatz durch:	Datum	
STUDER REGENSDORF ZÜRICH		Kopie für:	
Benennung: 24-CH SEL. STEREO			Nummer: 1.913.178-00

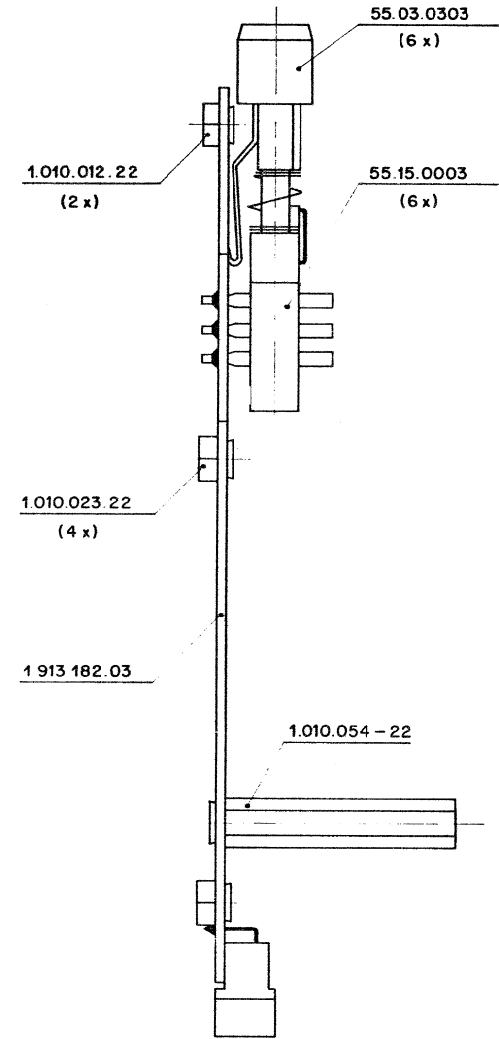
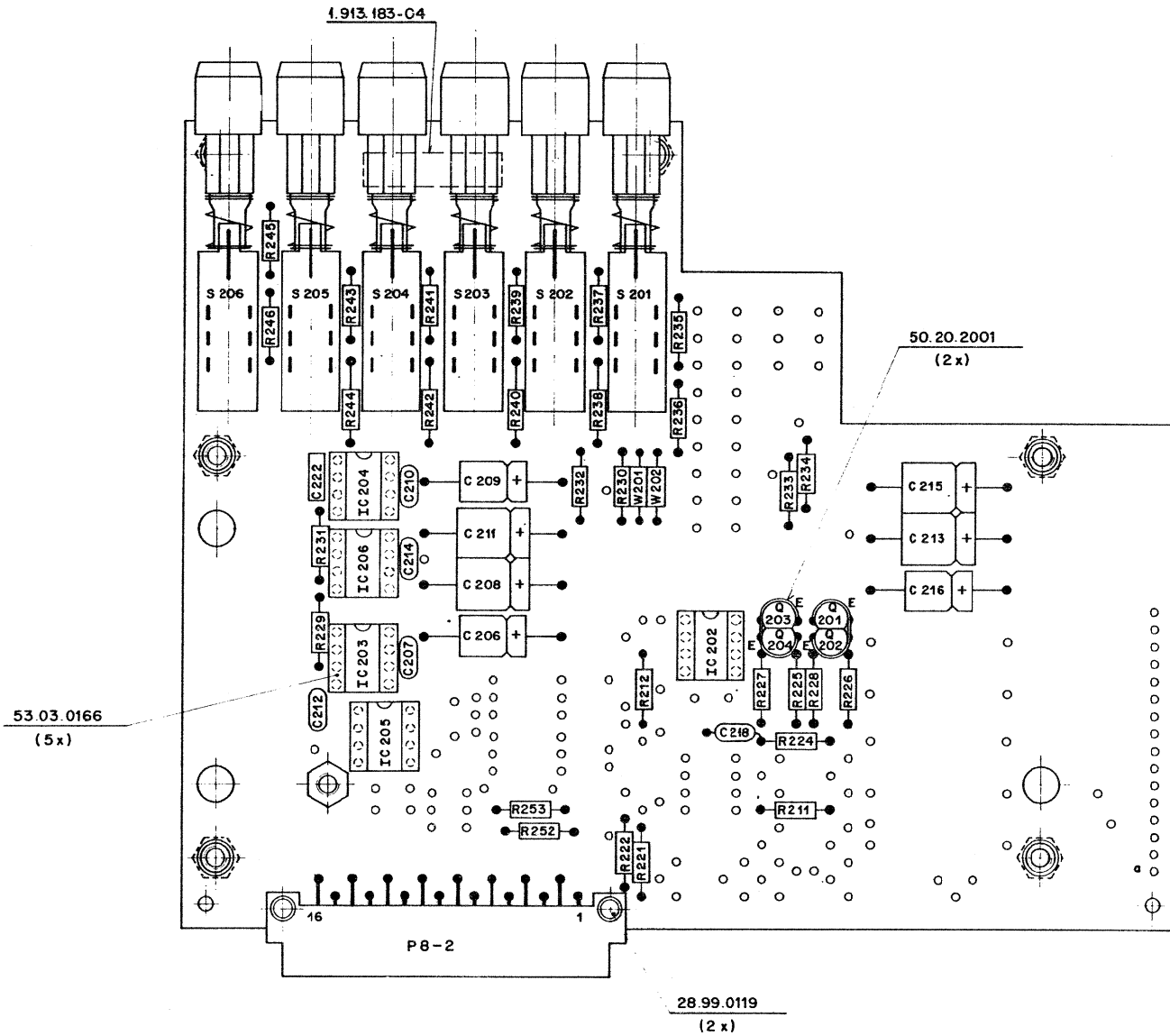

Werkstoff DIN-Bez Abmessung	Norm-Nr Güte		Änderung
	Oberfläche	Beh	
Zugehörige Unterlagen PL 1.913.478-00	Freimasstoleranz	Maßstab 2 : 1	Ausgabe 19.11.85 <i>de se. W</i>
Ersatz für	Ersetzt durch	Kopie für	
Benennung STUDER REGENSDORF ZÜRICH	6 SWITCH STEREO		Nummer 1.913.183 - 00

Ae.-Index 00 Ae.-Datum 03.05.85
 Kopieausgabe 16.44 Uhr am 15.04.86

Visum TA

Ae. Nummer Titel Bemerkungen

 00 1.913.178.00 24-CH-SEL. STEREO

Indo	Pcs.Nr.	Teil Nr.	Wert(Menge)	Bezeichnung	Hersteller

00	C...101	59.26.0470	47 uF	20% 6.3V SAL	
00	C...102	59.26.0470	47 uF	20% 6.3V SAL	
00	C...103	59.34.4101	100 pF		CE
00	C...104	59.34.4101	100 pF		CE
00	C...105	59.34.2330	33 pF		CE
00	C...106	59.22.3101	100 uF	-20% 10V EL	
00	C...107	59.26.0470	47 uF	20% 6.3V SAL	
00	C...108	59.26.0470	47 uF	20% 6.3V SAL	
00	C...109	59.34.4101	100 pF		CE
00	C...110	59.34.4101	100 pF		CE
00	C...111	59.34.2330	33 pF		CE
00	C...112	59.22.3101	100 uF	-20% 10V EL	
00	C...113		not used		
00	C...114		not used		
00	C...115		not used		
00	C...116	59.26.0470	47 uF	20% 6.3V SAL	
00	C...117	59.26.0470	47 uF	20% 6.3V SAL	
00	C...118		not used		
00	C...119		not used		
00	C...120	59.34.4101	100 pF		CE
00	C...121	59.34.4101	100 pF		CE
00	C...122	59.22.3101	100 uF	-20% 10V EL	
00	C...123	59.26.0470	47 uF	20% 6.3V SAL	
00	C...124	59.26.0470	47 uF	20% 6.3V SAL	
00	C...125	59.34.4101	100 pF		CE
00	C...126	59.34.4101	100 pF		CE
00	C...127	59.34.2330	33 pF		CE
00	C...128		not used		
00	C...129		not used		
00	C...130		not used		
00	C...131		not used		
00	C...132		not used		
00	C...133		not used		
00	C...134	59.34.2330	33 pF		CE
00	C...135	59.22.3101	100 uF	-20% 10V EL	
00	C...136	59.22.3101	100 uF	-20% 10V EL	
00	C...137	59.22.3101	100 uF	-20% 10V EL	
00	C...138	59.34.4101	100 pF		CE
00	C...139		not exist		
00	C...140	59.22.4101	100 uF	-20% 16V EL	
00	C...141	59.22.4101	100 uF	-20% 16V EL	
00	C...142		not used		
00	C...143		not used		
00	C...144		not used		
00	C...145		not used		
C2	C...146	59.34.5471	470 pF		CE
00	IC...101	50.05.0243	NE5534N	single op. amp.	Sig.Ra
00	IC...102		not used		

Ae.-Index 00 Ae.-Datum 03.05.85
 Kopieausgabe 16.44 Uhr am 15.04.86

Visum TA

Ind.	Pos.Nr.	Teil Nr.	Wert(Menge)	Bezeichnung	Hersteller
00	IC..103	50.05.0243	NE5534N	single op. amp.	Sig,Ra
C0	IC..104	50.09.0105	NE5532	dual op. amp.	Sig,Ex,Ra
00	IC..105	50.05.0243	NE5534N	single op. amp.	Sig,Ra
00	IC..106		not used		
C0	IC..107	50.05.0243	NE5534N	single op. amp.	Sig,Ra
00	IC..108	50.05.0243	NE5534N	single op. amp.	Sig,Ra
00	MP....1	53.03.0166	6 pcs	IC-socket 8 pin	
C0	P...8.1	54.01.0359	2*16pin	euroconnector	Bu
C0	R...101	57.11.3332	3.3 kOhm	1% 0.25W	
C0	R...102	57.11.3332	3.3 kOhm	1% 0.25W	
00	R...103	57.11.3332	3.3 kOhm	1% 0.25W	
C0	R...104	57.11.3332	3.3 kOhm	1% 0.25W	
00	R...105	57.11.4333	33 kOhm	5% 0.25W	
00	R...106	57.11.3332	3.3 kOhm	1% 0.25W	
C0	R...107	57.11.3332	3.3 kOhm	1% 0.25W	
00	R...108	57.11.3332	3.3 kOhm	1% 0.25W	
C0	R...109	57.11.3332	3.3 kOhm	1% 0.25W	
00	R...110	57.11.4333	33 kOhm	5% 0.25W	
C0	R...111		not used		
00	R...112		not used		
00	R...113		not used		
C0	R...114		not used		
00	R...115	1.912.001.35	10 kOhm	pos.log. combined with R116	St
00	R...116		10 kOhm	neg.log. see R115	
C0	R...117	57.11.4682	6.8 kOhm	5% 0.25W	
00	R...118	57.11.4682	6.8 kOhm	5% 0.25W	
C0	R...119	57.11.3132	1.3 kOhm	5% 0.25W	
C0	R...120	57.11.4332	3.3 kOhm	5% 0.25W	
C0	R...121	57.11.3132	1.3 kOhm	5% 0.25W	
C0	R...122	57.11.4332	3.3 kOhm	5% 0.25W	
C0	R...123	57.11.3332	3.3 kOhm	1% 0.25W	
C0	R...124		not used		
00	R...125	57.11.3332	3.3 kOhm	1% 0.25W	
00	R...126		not used		
C0	R...127	57.11.3332	3.3 kOhm	1% 0.25W	
C0	R...128	57.11.3332	3.3 kOhm	1% 0.25W	
C0	R...129	57.11.4332	3.3 kOhm	5% 0.25W	
00	R...130	57.11.4332	3.3 kOhm	5% 0.25W	
C0	R...131		not used		
C0	R...132	57.11.4101	100 Ohm	5% 0.25W	
00	R...133	57.11.4333	33 kOhm	5% 0.25W	
C0	R...134	57.11.4333	33 kOhm	5% 0.25W	
00	R...135	57.11.3332	3.3 kOhm	1% 0.25W	
C0	R...136		not used		
C0	R...137	57.11.3332	3.3 kOhm	1% 0.25W	
C0	R...138		not used		
00	R...139	57.11.3332	3.3 kOhm	1% 0.25W	
C0	R...140	57.11.3332	3.3 kOhm	1% 0.25W	
00	R...141		not used		
C0	R...142		not used		
00	R...143		not used		

Ae.-Index 00 Ae.-Datum 03.05.85
 Kopieausgabe 16.44 Uhr am 15.04.86

Visum TA

Ind.	Pos.Nr.	Teil Nr.	Wert (Menge)	Bezeichnung	Hersteller
CO	R...144		not used		
CO	R...145	57.11.4101	100 Ohm	5% 0.25W	
CO	R...146		not used		
CO	R...147		not used		
CO	R...148	57.11.4332	3.3 kOhm	2% 0.25W	
CO	R...149	57.11.4332	3.3 kOhm	2% 0.25W	
CO	R...150	57.11.4333	33 kOhm	5% 0.25W	
CO	R...151	57.11.4333	33 kOhm	5% 0.25W	
CO	R...152		not used		
CO	R...153		not used		
CO	R...154	57.11.4331	330 Ohm	5% 0.25W	
CO	R...155		not used		
CO	R...156	1.912.001.44	10 kOhm		
			10% pos.log.	combined with R157	St
CO	R...157		10 kOhm	10% pos.log. see R156	
CO	R...158	1.912.001.42	10 kOhm		
			10% pos.log.	variable resistor	St
CO	R...159	1.912.001.42	10 kOhm		
			10% pos.log.	variable resistor	St
CO	R...160	1.912.001.42	10 kOhm		
			10% pos.log.	variable resistor	St
CO	R...161	57.11.4332	3.3 kOhm	2% 0.25W	
CO	R...162	57.11.4332	3.3 kOhm	2% 0.25W	
CO	R...163	57.11.3242	2.4 kOhm	2% 0.25W	
CO	R...164		not used		
CO	R...165	57.92.1271	6.5 Ohm		
			I = 270mA	PTC Philips Nr.2322 662 12711	
CO	R...166	57.92.1271	6.5 Ohm		
			I = 270mA	PTC Philips Nr.2322 662 12711	
CO	R...167		not used		
CO	R...168		not used		
CO	R...169		not used		
CO	R...170	57.11.3242	2.4 kOhm	2% 0.25W	
CO	R...171	57.11.3242	2.4 kOhm	2% 0.25W	
CO	R...172	57.11.3242	2.4 kOhm	2% 0.25W	
CO	R...173	57.11.3242	2.4 kOhm	2% 0.25W	
CO	R...174	57.11.3242	2.4 kOhm	2% 0.25W	
CO	R...175	57.11.3242	2.4 kOhm	2% 0.25W	
CO	R...176	57.11.3242	2.4 kOhm	2% 0.25W	
CO	R...177	57.11.3242	2.4 kOhm	2% 0.25W	
CO	R...178	57.11.3242	2.4 kOhm	2% 0.25W	
CO	R...179	57.11.3242	2.4 kOhm	2% 0.25W	
CO	R...180	57.11.3242	2.4 kOhm	2% 0.25W	
CO	R...181	57.11.3242	2.4 kOhm	2% 0.25W	
CO	R...182		not used		
CO	R...183		not used		
CO	R...184		not used		
CO	R...185		not used		
CO	S...101	55.15.0003	2*U	3u Au button : red	ITT
CO	S...102	55.15.0003	2*U	3u Au button : red	ITT
CO	S...103	55.15.0003	2*U	3u Au button : red	ITT
CO	S...104	55.15.0003	2*U	3u Au button : red	ITT
CO	S...105	55.15.0003	2*U	3u Au button : red	ITT

Ae.-Index 00 Ae.-Datum 03.05.85
 Kopieausgabe 16.44 Uhr am 15.04.86

Visum TA

Ind.	Pos.Nr.	Teil Nr.	Wert (Menge)	Bezeichnung	Hersteller
CO	S...106	55.15.0003	2*U	3u Au button : red	ITT
CO	S...107		not used		
CO	S...108	55.15.0003	2*U	3u Au button : red	ITT
00	W...101				
00	W...102				
CO	W...103		not used		
CO	W...104		not used		
00	W...105		not used		
00	W...106				
CO	W...107				
CO	W...108				
CO	W...109		not used		
CO	W...110		not used		
00	W...111		not used		
CO	W...112		not used		
00	W...113				
CO	W...114		not used		
CO	W...115		not used		
CO	W...116				
CO	W...117				
CO	W...118		not used		
QQ	W...119		not used		
00	W...120	1.010.300.64	8-wire	flatcable	40 mm
CO	W...121	1.010.300.64	8-wire	flatcable	40 mm
00	W...122				
00	W...123				
00	W...124		not used		
CO	W...125		not used		
CO	C...201		not used		
CO	C...202		not used		
CO	C...203		not used		
CO	C...204		not used		
00	C...205		not used		
CO	C...206	59.25.3470	47 uF	-20% 16V	EL
CO	C...207	59.34.2330	33 pF		CE
00	C...208	59.25.1221	220 uF	-20% 6.3V	EL
00	C...209	59.25.3470	47 uF	-20% 16V	EL
00	C...210	59.34.2330	33 pF		CE
CO	C...211	59.25.1221	220 uF	-20% 6.3V	EL
CO	C...212	59.34.2330	33 pF		CE
00	C...213	59.25.1221	220 uF	-20% 6.3V	EL
00	C...214	59.34.2330	33 pF		CE
CO	C...215	59.25.1221	220 uF	-20% 6.3V	EL
00	C...216	59.25.3470	47 uF	-20% 16V	EL
00	C...217		not used		
Q1	C...218	59.32.4102	1 nF		CE
00	C...219		not used		
CO	C...220		not used		
00	C...221		not used		
CO	C...222	59.06.0223	22 nF		PE
CO	C...223		not used		
00	C...224		not used		

Ae.-Index 00 Ae.-Datum 03.05.85
 Kopieausgabe 16.44 Uhr am 15.04.86

Visum TA

Ind.	Pos.-Nr.	Teil Nr.	Wert(Menge)	Bezeichnung	Hersteller
C0	IC..201		not used		
00	IC..202	50.09.0105	NE5532	dual op. amp.	Sig,Ex,Ra
C0	IC..203	50.05.0243	NE5534N	single op. amp.	Sig,Ra
00	IC..204	50.05.0243	NE5534N	single op. amp.	Sig,Ra
00	IC..205	50.05.0243	NE5534N	single op. amp.	Sig,Ra
C0	IC..206	50.05.0243	NE5534N	single op. amp.	Sig,Ra
00	MP....1	53.03.0166	5 pcs	IC-socket 8 pin	
00	MP....2	50.20.2001	2 pcs	CLIP ; 2 * TO 92	St
00	P...8.2	54.11.2007	2*8 pin	euroconnector	Bu
C0	Q...201	50.03.0516	BC 337	NPN matched with Q 202	Sie
C0	Q...202	50.03.0516	BC 337	NPN	Sie
00	Q...203	50.03.0625	BC 327	PNP matched with Q 204	Sie
C0	Q...204	50.03.0625	BC 327	PNP	Sie
C0	R...201		not used		
C0	R...202		not used		
C0	R...203		not used		
C0	R...204		not used		
C0	R...205		not used		
00	R...206		not used		
C0	R...207		not used		
00	R...208		not used		
00	R...209		not used		
C0	R...210		not used		
C0	R...211	57.11.4101	100 Ohm	5% 0.25W	
00	R...212	57.11.4101	100 Ohm	5% 0.25W	
C0	R...213		not used		
00	R...214		not used		
C0	R...215		not used		
C0	R...216		not used		
C0	R...217		not used		
C0	R...218		not used		
C0	R...219		not used		
C0	R...220		not used		
00	R...221	57.11.4101	100 Ohm	5% 0.25W	
00	R...222	57.11.4101	100 Ohm	5% 0.25W	
C0	R...223		not used		
00	R...224	57.11.4101	100 Ohm	5% 0.25W	
C0	R...225	57.11.4103	10 kOhm	5% 0.25W	
00	R...226	57.11.4103	10 kOhm	5% 0.25W	
00	R...227	57.11.4101	100 Ohm	5% 0.25W	
C0	R...228	57.11.4101	100 Ohm	5% 0.25W	
00	R...229	57.11.4683	68 kOhm	5% 0.25W	
C0	R...230	57.11.4333	33 kOhm	5% 0.25W	
C0	R...231	57.11.4683	68 kOhm	5% 0.25W	
00	R...232	57.11.4333	33 kOhm	5% 0.25W	
00	R...233	57.11.4333	33 kOhm	5% 0.25W	
C0	R...234	57.11.4333	33 kOhm	5% 0.25W	
00	R...235	57.11.3242	2.4 kOhm	2% 0.25W	
00	R...236	57.11.3242	2.4 kOhm	2% 0.25W	

Ae.-Index 00 Ae.-Datum: 03.05.85
 Kopieausgabe 16.44 Uhr am 15.04.86

Visum TA

Ind.	Pos.Nr.	Teil Nr.	Wert (Menge)	Bezeichnung	Hersteller
00	R...237	57.11.3242	2.4 kOhm	2% 0.25W	
C0	R...238	57.11.3242	2.4 kOhm	2% 0.25W	
C0	R...239	57.11.3242	2.4 kOhm	2% 0.25W	
00	R...240	57.11.3242	2.4 kOhm	2% 0.25W	
C0	R...241	57.11.3242	2.4 kOhm	2% 0.25W	
C0	R...242	57.11.3242	2.4 kOhm	2% 0.25W	
00	R...243	57.11.3242	2.4 kOhm	2% 0.25W	
00	R...244	57.11.3242	2.4 kOhm	2% 0.25W	
00	R...245	57.11.3242	2.4 kOhm	2% 0.25W	
C0	R...246	57.11.3242	2.4 kOhm	2% 0.25W	
C0	R...247		not used		
C0	R...248		not used		
C0	R...249		not used		
00	R...250		not used		
C0	R...251		not used		
C0	R...252	57.11.3242	2.4 kOhm	5% 0.25W	
C0	R...253	57.11.3242	2.4 kOhm	5% 0.25W	
00	S...201	55.15.0003	2*U	3u Au button : red	ITT
00	S...202	55.15.0003	2*U	3u Au button : red	ITT
C0	S...203	55.15.0003	2*U	3u Au button : red	ITT
00	S...204	55.15.0003	2*U	3u Au button : red	ITT
C0	S...205	55.15.0003	2*U	3u Au button : red	ITT
00	S...206	55.15.0003	2*U	3u Au button : red	ITT
C0	h...201				
C0	h...202				

CE=Ceramic, CF=Carbon Film, EL=Electrolytic, MF=Metal Film,
 PE=Polyester, PP=Polypropylen, PS=Polystyrol

MANUFACTURER: Bu=Burndy, Ex=Exar, Fc=Fairchild, GI=General Instrument
 HP=Hewlett Packard, ITT=Intermetall, Mot=Motorola, Nat=N
 [Matsushita], NS=National Semiconductors, Ph=Philips,
 Ra=Raytheon, Sig=Signetics, Six=Siliconix, St=Studer,
 TI=Texas Instrument

Ende der Positions Liste.

1.913.176

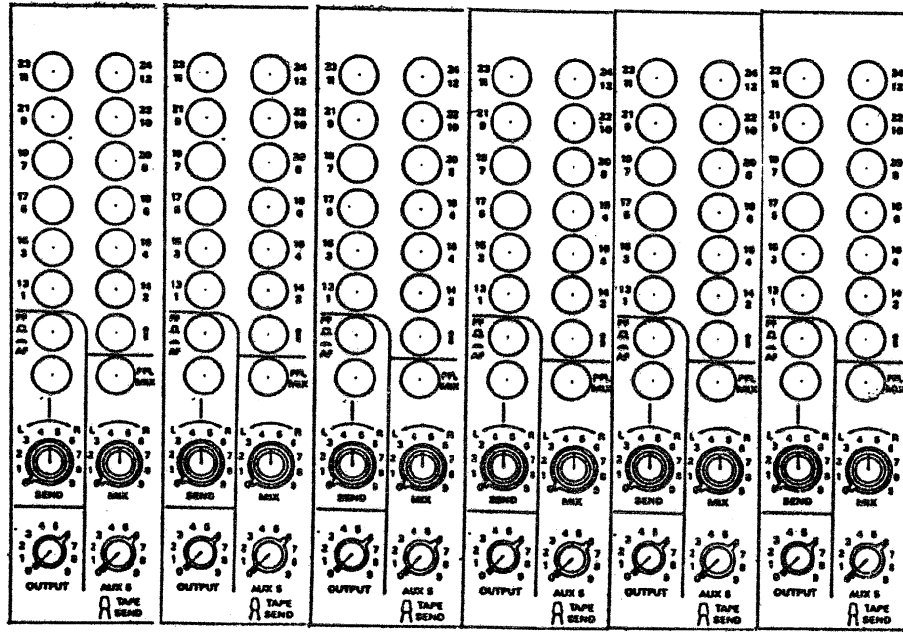

1.913.177

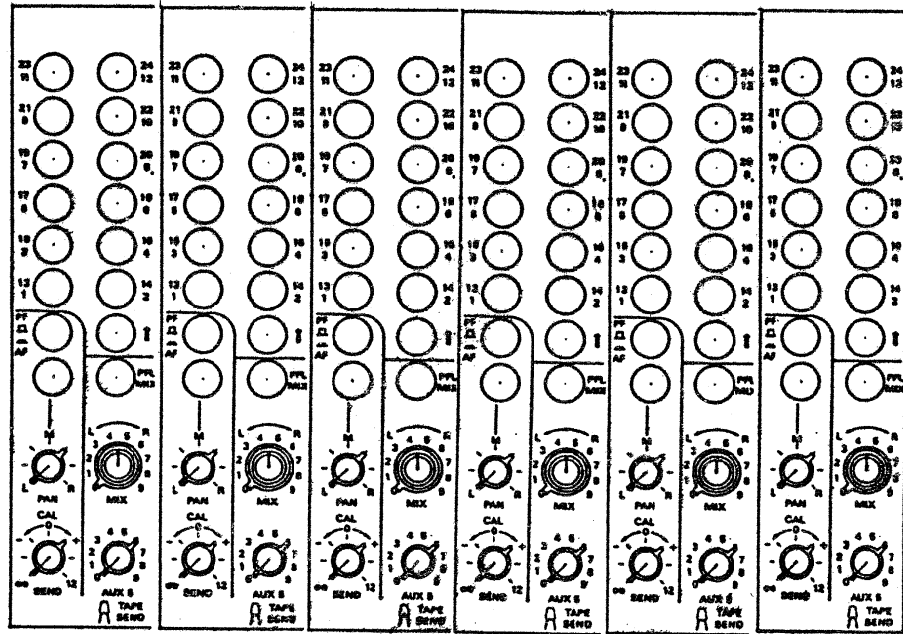
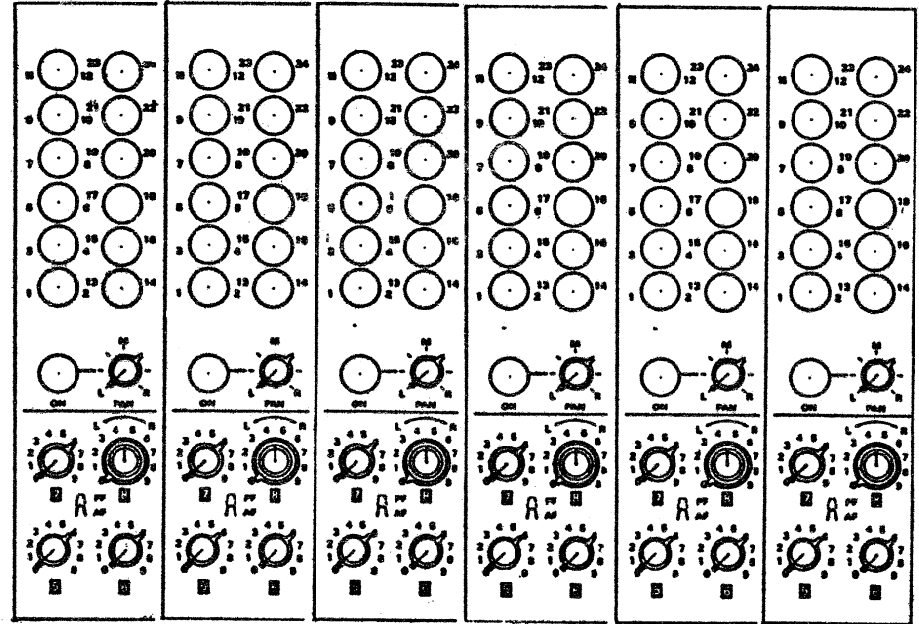

1.913.175

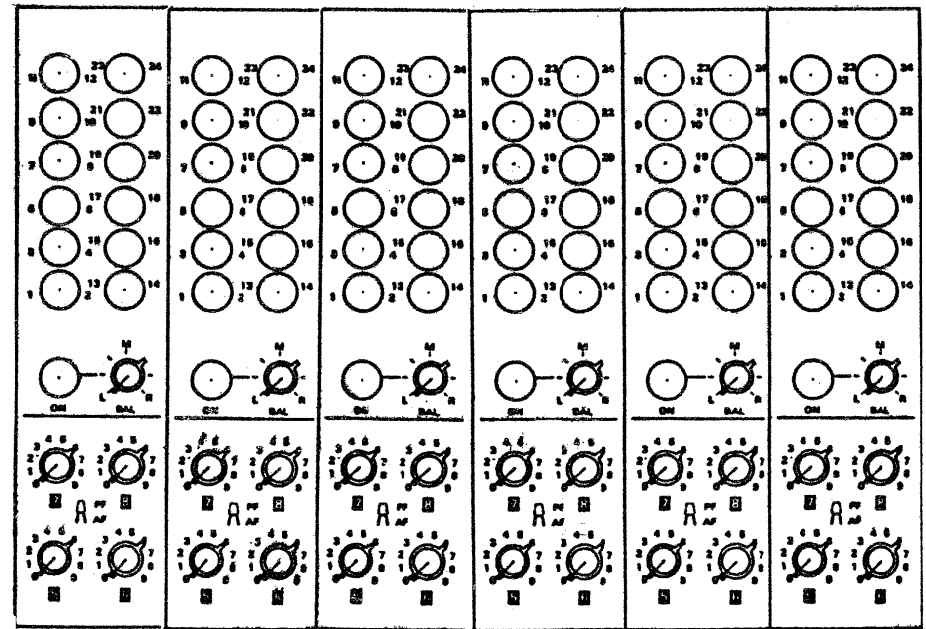

1.913.178

PFL Amplifier 1.913.200

PFL-AMPLIFIER

3 Watt Verstärker mit Lautsprecher für Vorhören und Intercom.

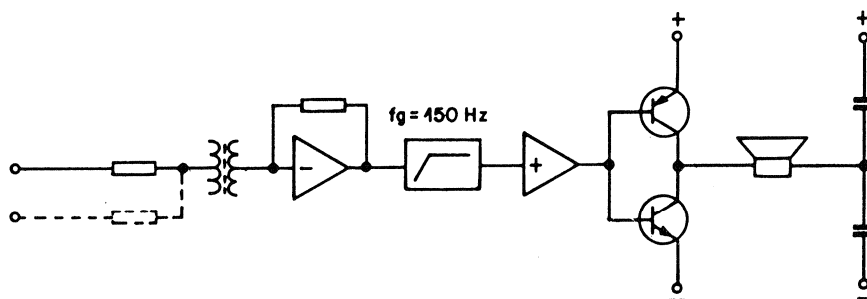
Blockschaltbild:PFL AMPLIFIER

3-Watt amplifier with speaker for pre-listening and intercom.

BLOCK DIAGRAM

TECHNISCHE DATEN

Eingangsspannung: 0 dB für	0,3 Watt
Eingangswiderstand	> 10 kOhm
Isolation	500 V
Verstärkung	9 dB
Frequenzgang @ 15 kHz	-0,5 dB
Filter fg	150 Hz / 12 dB / Oct.
Klirrfaktor @ 2 Watt	< 0,5 %
Max. Ausgangsleistung	3 Watt
Speisespannung	- 24 V
Ruhestrom / Strom bei max. Aussteuerung	33 / 220 mA
Fremdspannung	< - 90 dBu

MECHANISCHE DATEN

Frontplatte dunkelgrau gespritzt	170 x 80 mm
Abmessung der Frontplatte	135 mm
Tiefe	350 gr
Gewicht	

Specifications

Input voltage: 0 dBu for	0,3 W
Input impedance	> 10 kohm
Insulation rating	500 V
Gain	9 dB
Frequency response at	15 kHz
Filter fg	- 0,5 dB
Distortion at 2 W	150 Hz / 12 dB / oct
Maximum output power	< 0,5 %
Supply voltage	3 W
Current open-circuit/ fully driven	-24 V
Output noise	33/220 mA
	< -90 dBu

Physical Data

Front panel laquered charcoal grey	
Dimensions of front panel	170 x 80 mm
Depth	135 mm
Weight	350 g

PFL Amplifier 1.913.200

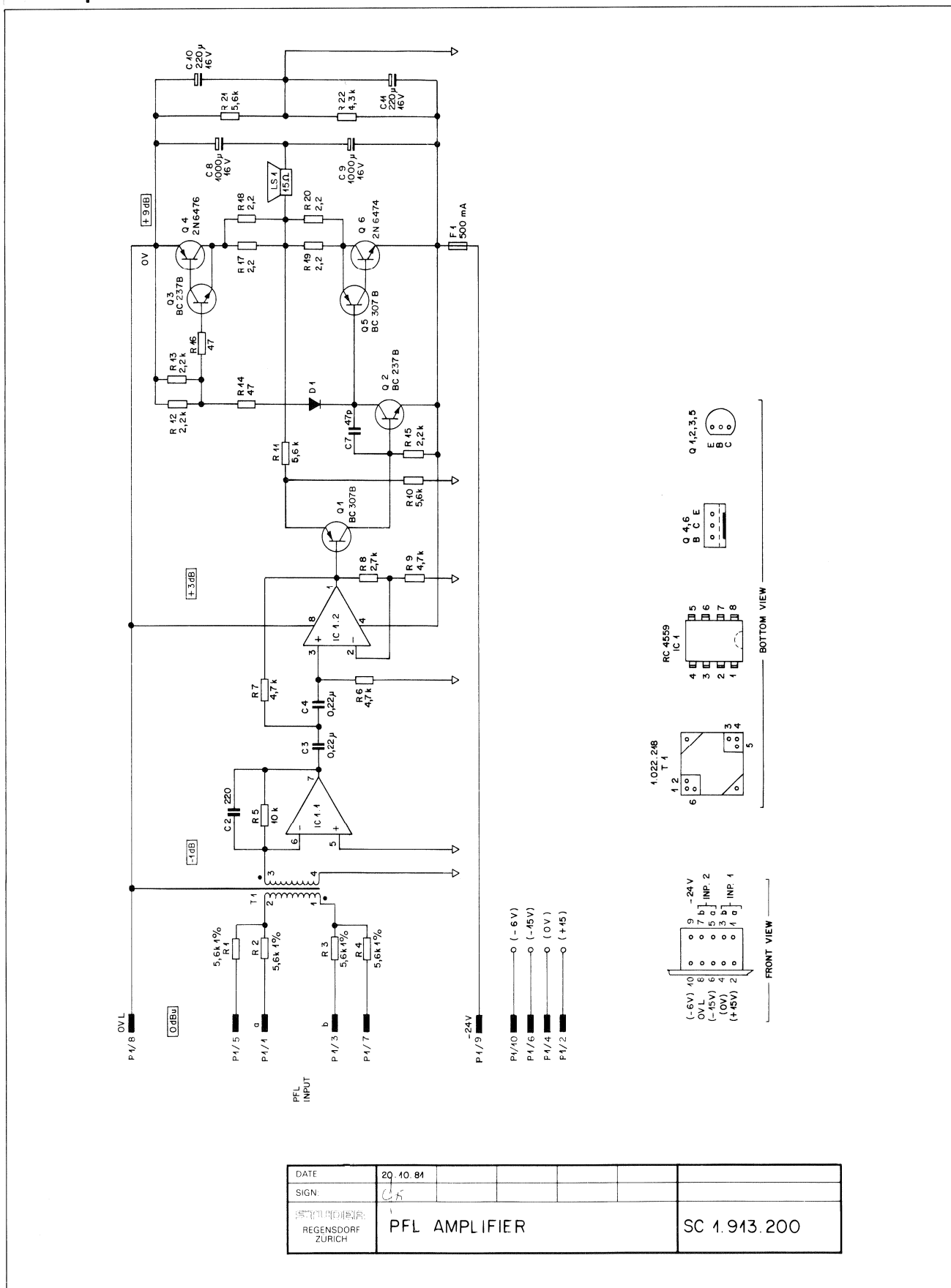

DATE	20.10.84				
SIGN.	<i>CS</i>				
REGENDORF ZÜRICH	PFL AMPLIFIER			SC 1.913.200	

PFL Amplifier 1.913.200

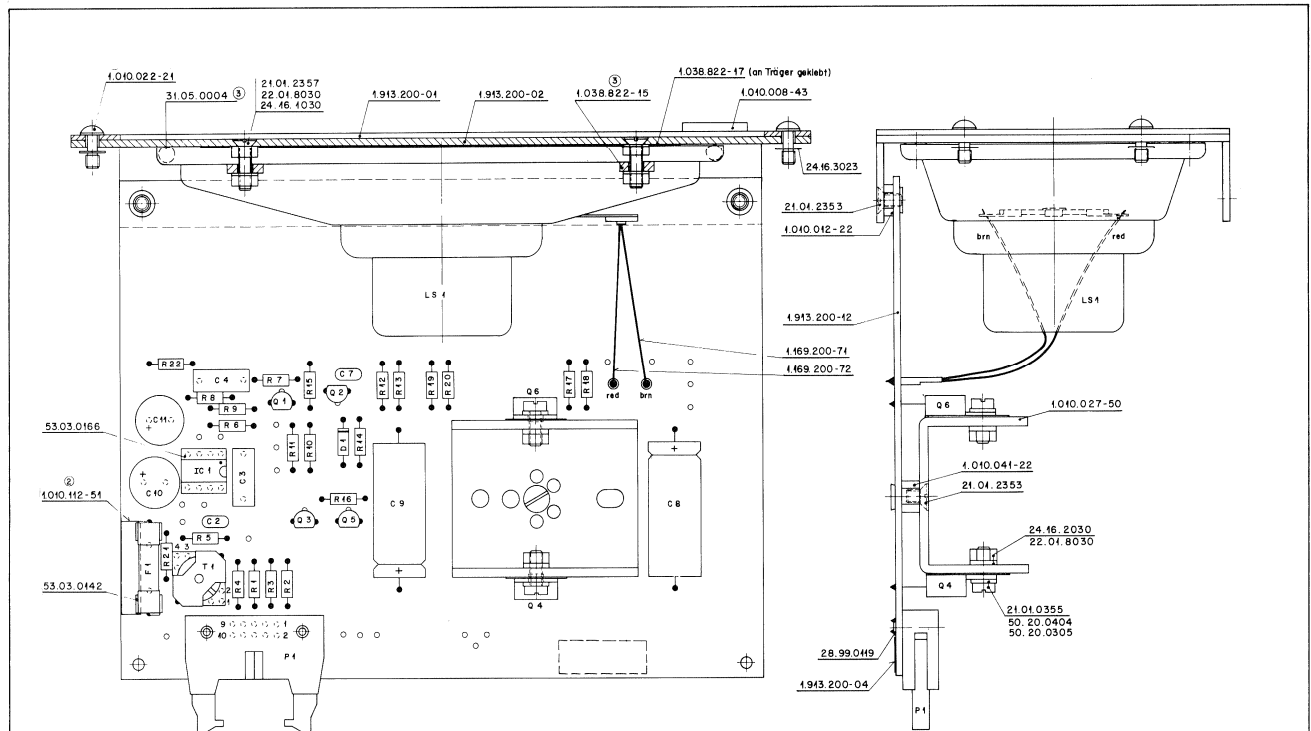

Norm-Nr.:	Qüte:	1.6.85	A.Ho	1/1	1/1
DIN-Bez.:	Umfeld:	6.11.84	A.Ho	1/1	1/1
Abmessung:	Maß:	4.1.84	A.Ho	1/1	1/1
Zugehörige Unterlagen:	Freimaschinen:	2.1			
Ersetzt für:	Ersetzt durch:				
STUDER REGENSDORF ZÜRICH		PFL- Amplifier		1.913.200-00	

INDI POS NO	PART NO	VALUE	SPECIFICATIONS/EQUIVALENT	MFR
C 1				
C 2	59.34.4221	220 pF		CER
C 3	59.12.2224	0,22 µF	5%	PE
C 4	59.12.2224	0,22 µF	5%	PE
C 5				
C 6				
C 7	59.34.2470	47 pF		CER
C 8	59.25.3102	1000 µF	16V	EL
C 9	59.25.3102	1000 µF	16V	EL
C 10	59.22.4221	220 µF	16V	EL
C 11	59.22.4221	220 µF	16V	EL
D 1	50.04.0125	M4448		SI
F 1	50.04.0114	500 mA	SB	
IC 1	50.09.0102	RC4553	DUAL	OPA Pz
LS 1	71.01.0108	15 Ω	3W	Ph
Q 1	50.03.0515	BC107B	PNP LF all purpose	SI om4
Q 2	50.03.0436	BC239B	NPN LF all purpose	SI om4
Q 3	50.03.0436	BC239B	NPN LF all purpose	SI om4
Q 4	50.03.0345	2N6476	PNP Power T0220	SI A
Q 5	50.03.0515	BC107B	PNP LF all purpose	SI om4
Q 6	50.03.0344	2N6477A	NPN Power T0220	R
R 1	57.11.3562	5,6k	1%	
R 2	57.11.3562	5,6k	1%	
R 3	57.11.3562	5,6k	1%	
R 4	57.11.3562	5,6k	1%	
R 5	57.11.4102	10k		
R 6	57.11.4472	4,7k	2%	

INDI POS NO	PART NO	VALUE	SPECIFICATIONS/EQUIVALENT	MFR
R 7	57.11.4472	4,7k	2%	
R 8	57.11.4222	2,2k	2%	
R 9	57.11.4472	4,7k	2%	
R 10	57.11.3562	5,6k		
R 11	57.11.3562	5,6k		
R 12	57.11.4222	2,2k		
R 13	57.11.4222	2,2k		
R 14	57.11.4470	4,7		
R 15	57.11.4223	22k		
R 16	57.11.4470	4,7		
R 17	57.11.4229	2,2		
R 18	57.11.4229	2,2		
R 19	57.11.4229	2,2		
R 20	57.11.4229	2,2		
R 21	57.11.3562	5,6k	1%	
R 22	57.11.3432	4,3k	1%	
T 1	1.022.248	1:1	Input Trans	ST

INDI	DATE	NAME
③		
②		
①	6.11.84	Uff
①	14.8.81	Uff

CER - Ceramic Ph - Philips
PE - Polyester R - RCA
EL - Electrolytic R - Raytheon

STUDER PFL - AMPLIFIER 1.913.200.00 PAGE 1 OF 2

INDI	DATE	NAME
④		
③		
②		
①	14.8.81	Uff

ST - STUDER

STUDER PFL AMPLIFIER 1.913.200.00 PAGE 2 OF 2

KORRELATOR

Der Korrelator zeigt die Phasenkorrelation einer Stereoaufnahme an.

Die Phasenkorrelation ist die gegenseitige Beziehung der Phasen beider Kanäle.

Wenn die Signale beider Kanäle gleichphasig sind, z.B. bei Monoaufnahmen, zeigt das Korrelationsinstrument +1 an; wenn sie gegenphasig ($+180^\circ$) sind, zeigt das Instrument -1 an. Bei einem Stereo-Programm wird ein Mittelwert von gleich- und gegenphasigen Signalen angezeigt.

Stereoprogramme weisen normalerweise einen positiven Korrelationswert auf, vorzugsweise um +0,5. Negative Werte zeigen eine Phasenvertauschung im System an.

ANWENDUNGEN, DIE EINEN KORRELATOR ERFORDERN:Monokompatibilität von Stereoprogrammen

Damit eine stereophone Aufnahme auch monophon abgehört werden kann, muss die Korrelation überwacht werden.

Gegenphasige Anteile führen zu partiellen Auslöschungen.

Tiefe Frequenzen auf Stereo-Schallplatten

Die Abtastfähigkeit eines Abtastsystems ist für vertikale Auslenkung viel geringer als für horizontale Auslenkung.

Gegenphasige Signale mit hohem Pegel und tiefen Frequenzen weisen eine grosse vertikale Auslenkung auf und müssen deshalb vermieden werden.

Modulation von FM-Stereosendern

Die FM-Strecke Sender-Empfänger ist sehr empfindlich auf übermässig hohe Frequenzdifferenz-Signale. Es entstehen dabei unzulässige Verzerrungen.

CORRELATOR

The correlator indicates the phase correlation of a stereo program.

The phase correlation is the mutual relation of the phases on both channels.

If the signals of both channels are in phase, e.g. in a mono production, the correlation instrument indicates +1, if they are phased inversely ($+180^\circ$), the instrument indicates -1. The correlator always indicates the average of in-phase and antiphase signals of a stereo production.

Stereo programs normally show a positive correlation value, preferably around +0.5. Negative values indicate that the phase in the system is inverted.

APPLICATION WHICH REQUIRE A CORRELATORMono compatibility of stereo programs

To ensure that a stereo recording can also be reproduced in mono mode it is necessary to monitor the correlation.

No phased-inversed components are allowed because they partially cancel during monophonic reproduction.

Low frequencies on stereo records

The tracking capability of a cartridge is much lower for vertical excursion than for horizontal excursion.

Antiphase signals with high levels and low frequencies result in high vertical excursion and should, therefore, be avoided.

Modulation from FM stereo transmitters

The FM path from the transmitter to the receiver is very sensitive to excessively high frequency-difference signals. They produce unacceptable distortion.

Blockschaltbild

Block Diagram

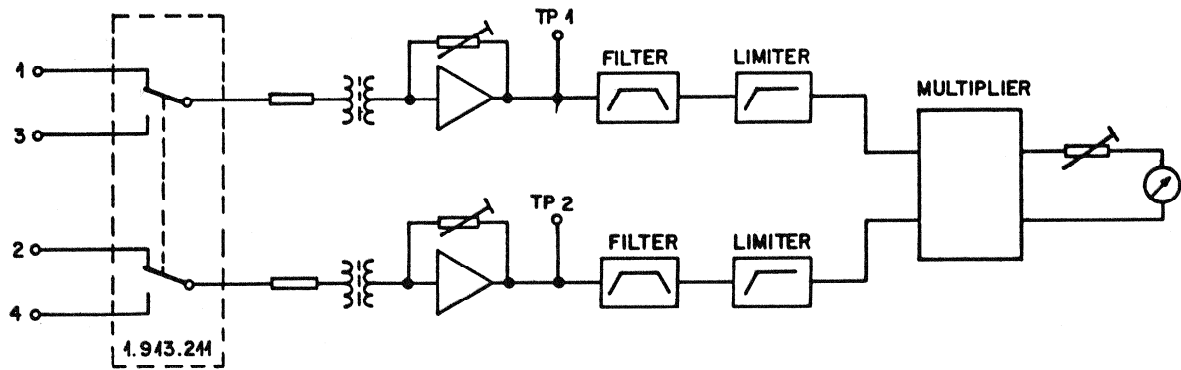

Abgleich

Calibration

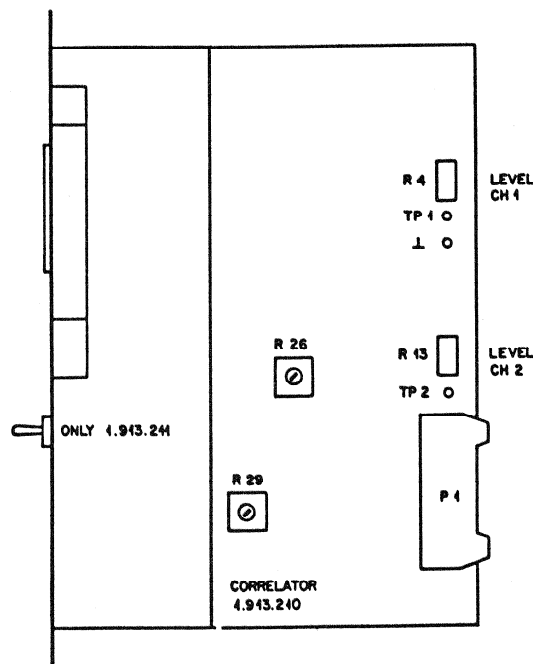

1. An beiden Eingängen wird ein gleichphasiges 1 kHz-Signal mit Leitungspegel eingespiesen. R4 bzw. R13 so einstellen, dass an den Messpunkten TP1 bzw. TP2 ein Pegel von 100 mV AC gegen \perp (Masse) erscheint.
2. Eingangspegel um 50 dB verringern. KO an den Ausgang 6 oder 9 von IC3 gegen Masse \perp anschliessen. Die Amplituden beider Halbwellen mit R29 auf gleiche Höhe einstellen.
3. Eingangspegel wieder auf Leitungspegel einstellen. Mit R26 den Zeiger des Anzeigeelementes auf +1 einstellen.
4. Einen der beiden Eingänge umpolen. Das Messinstrument soll -1 anzeigen.
5. Anzeigen gemäss Fig A kontrollieren.

1. Feed both inputs with an in-phase signal (1 kHz, line level). Adjust R4 and R13 in such a manner that 100 mV AC appear at both test points TP1 or TP2, against ground.
2. Reduce the input level by 50 dB. Connect oscilloscope to pin 6 or 9 of IC3 to ground. With R29 adjust the amplitudes of both half-waves to equal height.
3. Restore input level to line level. With R26 adjust the pointer of the meter to +1.
4. Reverse the polarity of one of the inputs. The meter should indicate -1.
5. Check meter readings according to Fig. A.

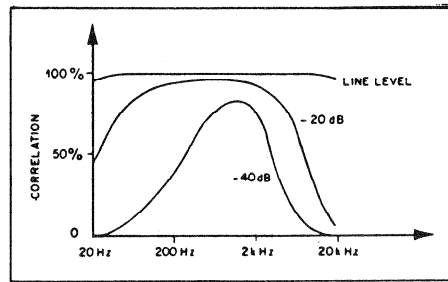

EINGANG	30 Hz	1 kHz	15 kHz
Leitungspegel = A	0,95	1	0,95
A + 20 dB	~1	1	~1
A - 20 dB	0,6	~1	0,5

INPUT	30 Hz	1 kHz	15 kHz
Line level = A	0,95	1	0,95
A + 20 dB	~1	1	~1
A - 20 dB	0,6	~1	0,5

TECHNISCHE DATEN

Eingang

symmetrisch und erdfrei
 Eingangsimpedanz 20 Hz ... 20 kHz: >10 kOhm
 Eingangspegel, einstellbar: +6 ... +15 dBu

Filter

Hochpass 6 dB/Oktave: f_u . ca. 340 Hz
 Tiefpass 12 dB/Oktave: f_o . ca. 3,4 kHz

Ausgang

Ausgangsstrom für Instrumente, einstellbar \pm 300 μ A

Temperatureinfluss

Fehler bei 0° C ... 50° C, bezüglich Raumtemperatur: +3 ... -1 %

Stromaufnahme bei \pm 15 V: ca. 15 mA

Mechanische Daten

Frontplatte dunkelgrau gespritzt
 Abmessung Frontplatte 170 x 180 mm
 Tiefe 135 mm
 Gewicht 390 gr

SPECIFICATIONS

Input

Balanced and floating
 Input impedance 20 Hz ... 20 kHz: 10 kOhm
 Input level, variable: + 6 ... + 15 dBu

Filter

High-pass 6 dB/octave: f_1 approx. 340 Hz
 Low-pass 12 dB/octave: f_u . approx. 3.4 kHz

Output

Output current for instruments, variable
 \pm 300 μ A.

Influence of temperature

Error at 0 C ... 50 C, relative to room temperature: + 3 ... - 1 %.

Connected load at \pm 15 V: approx. 15 mA

Physical data

Front panel laquered charcoal grey
 Dimensions of front panel 170 x 180 mm
 Depth 135 mm
 Weight 390 g

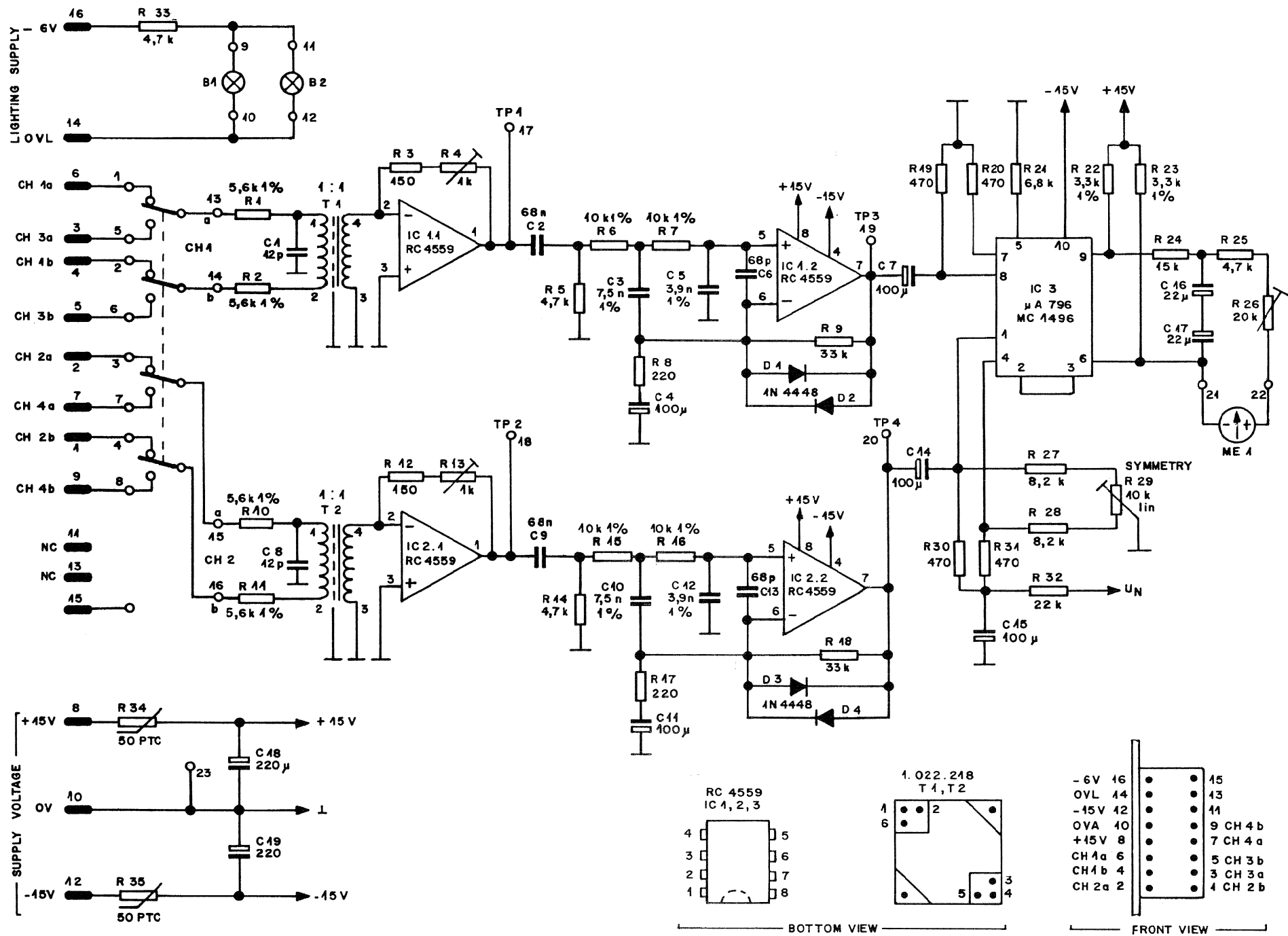

DATE:	18.10.82			
SIGN:	<i>[Signature]</i>			
STUDER REGENSDORF ZÜRICH	CORRELATOR 2CH/4CH			SC 1.913.210/211

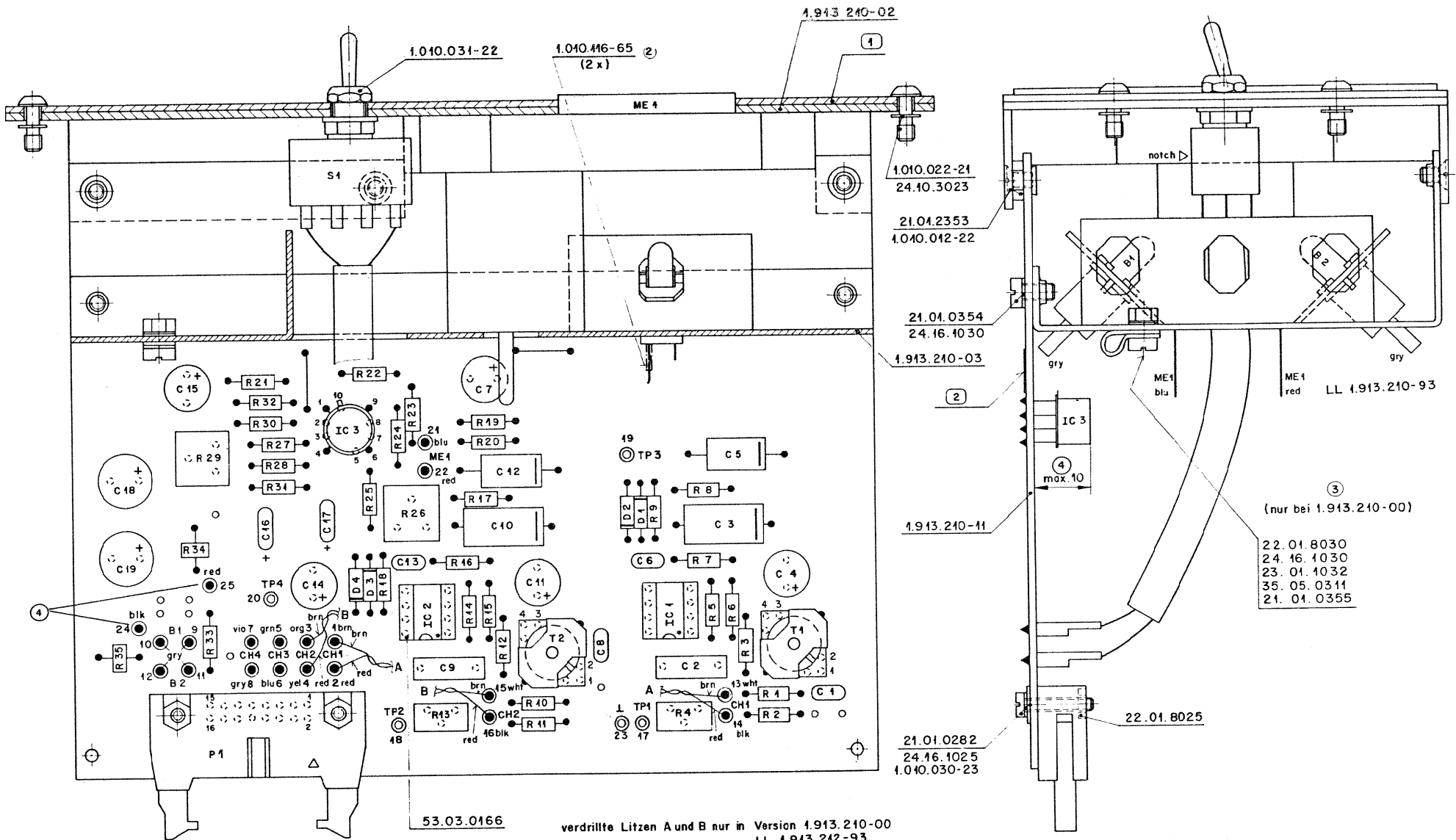

nur in Version 1.913.211-00
LL 1.913.211-93

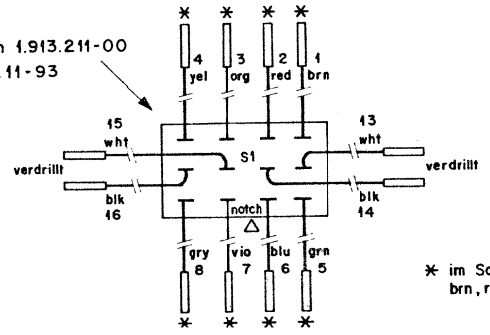

53.03.0166
verdrihte Litzen A und B nur in Version 1.913.210-00
LL 1.913.212-93

Gilt für :	(1)	(2)	
2 CH	1.913.210-00	1.913.210-01	1.913.210-04
4 CH	1.913.211-00	1.913.211-01	1.913.211-04

* im Schlauch 65.03.0146:
brn, red, org, yel, grn, blu, vio, gry

Werkstoff	Norm-Nr.:	Gute:	30.1188	H	V	V	(4)				
								DIN-Bez.:	Oberfläche	Beh:	12.11.86 A.Ho
Abmessung			10.12.84 A.Ho	M	V	V	(2)				
Zugehörige Unterlagen:	PL	Freimasstoleranz:	4.1.84 A.Ho	M	V	V	(1)				
Ersatz für:		Maßstab:	9.2.83 A.Ho	M	V	V	(0)				
Benennung: CORRELATOR 2 CH / 4 CH		Kopie für:	Datum					Gez.	Gepr.	Ges.	Index
REGENSDORF ZÜRICH		Nummer: 1.913.210-00									

IND	POS NO	PART NO	VALUE	SPECIFICATIONS/EQUIVALENT	MFR
	C 1	59.34.1120	12pF	5%	
	C 2	59.02.5683	68nF	5%	
	C 3	59.12.7752	75nF	1%	
	C 4	59.22.5101	100μF	16V	
	C 5	59.12.7392	39nF	1%	
	C 6	59.34.4680	68pF	5%	
	C 7	59.22.5101	100μF	16V	
	C 8	59.34.1120	12pF	5%	
	C 9	59.02.5683	68nF	5%	
	C 10	59.12.7752	75nF	1%	
	C 11	59.22.5101	100μF	16V	
	C 12	59.12.7392	39nF	1%	
	C 13	59.34.4680	68pF	5%	
	C 14	59.22.5101	100μF	16V	
	C 15	59.22.5101	100μF	16V	
	C 16	59.26.1220	22μF	10V	
	C 17	59.26.1220	22μF	10V	
	C 18	59.22.4221	220μF	16V	
	C 19	59.22.4221	220μF	16V	
	D 1	50.04.0125	1N4448		
	D 2	50.04.0125	1N4448		
	D 3	50.04.0125	1N4448		
	D 4	50.04.0125	1N4448		
	IC 1	50.09.0107	4559		Ra, TI
	IC 2	50.09.0107	4559		
	IC 3	50.05.0122	MC4966	μA796 HC	M, F

IND	DATE	NAME	
④			
③			
②			
①			
○	20-8-81	114	
STUDER		CORRELATOR 2CH 1.913.211	PAGE 1 OF 3

IND	POS NO	PART NO	VALUE	SPECIFICATIONS/EQUIVALENT	MFR
	R 1	57.11.3562	5,6k	1%	
	R 2	57.11.3562	5,6k	1%	
	R 3	57.11.4151	150		
	R 4	58.01.7102	1k	TRIM-POTM.	
	R 5	57.11.4472	47k		
	R 6	57.11.3103	10k	1%	
	R 7	57.11.3103	10k	1%	
	R 8	57.11.4221	220		
	R 9	57.11.4333	33k		
	R 10	57.11.3562	5,6k	1%	
	R 11	57.11.3562	5,6k	1%	
	R 12	57.11.4151	150		
	R 13	58.01.7102	1k	TRIM-POTM.	
	R 14	57.11.4472	47k		
	R 15	57.11.3103	10k	1%	
	R 16	57.11.3103	10k	1%	
	R 17	57.11.4221	220		
	R 18	57.11.4333	33k		
	R 19	57.11.4471	470		
	R 20	57.11.4471	470		
	R 21	57.11.4682	6,8k		
	R 22	57.11.3332	3,3k	1%	
	R 23	57.11.3332	3,3k	1%	
	R 24	57.11.4153	15k		
	R 25	57.11.4472	47k		
	R 26	58.01.8203	20k	TRIM-POTM.	
	R 27	57.11.4822	8,2k		
	R 28	57.11.4822	8,2k		
	R 29	58.01.8103	10k	TRIM-POTM.	
	R 30	57.11.4471	470		

IND	DATE	NAME	
④			
③			
②			
①			
○	20-8-81	114	
STUDER		CORRELATOR 2CH 1.913.211	PAGE 2 OF 3

IND	POS NO	PART NO	VALUE	SPECIFICATIONS/EQUIVALENT	MFR
	R 31	57.11.4471	470		
	R 32	57.11.4223	22k		
	R 33	57.11.4479	47		
	R 34	57.99.0206	50	PTC	
	R 35	57.99.0206	50	PTC	
	S 1	55.01.0115	4x ON-ON	only 1.913.211	
	T 1	1.022.218	1:1	INPUT TRAFO	STUDER
	T 2	1.022.218	1:1	INPUT TRAFO	STUDER
	B 1	51.02.0144	6V, 30mA	Lamp	
	B 2	51.02.0144	6V, 30mA	Lamp	
	ME 1	1.913.001.03		Corr-Meter	
	P 1	54.14.2012		Connector, 16pins	
	XIC	53.03.0166		IC-Socket, 8pins	

IND	DATE	NAME	
④			
③			
②			
①			
○	20-8-81	114	
STUDER		CORRELATOR 2CH 1.913.211	PAGE 3 OF 3

PEAK PROGRAM METER

Aussteuerungsmesser mit symmetrisch, erd-freiem Eingang. Dynamisches Verhalten gemäss IEC / DIN Normen.

Blockschaltbild

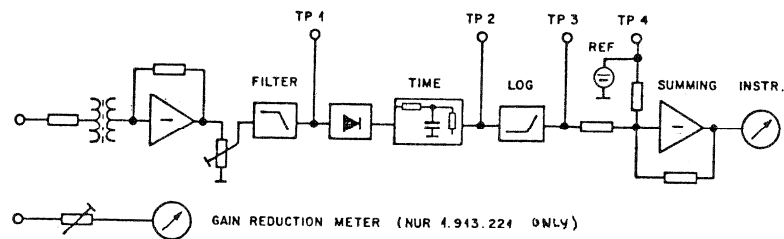

PEAK PROGRAM METER

Level indicator with balanced and floating input. Dynamic response according to IEC / DIN standards.

Block Diagram

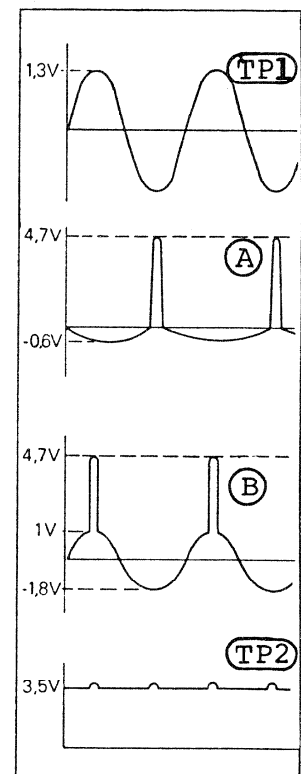
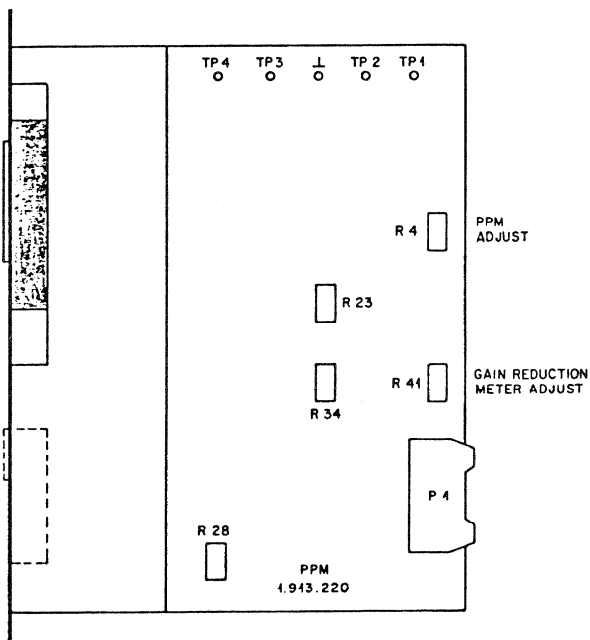

Abgleich

- 1) Leitungspegel + 6 ... + 15 dB 1 kHz am Eingang.
- 2) + 3,5 V an TP2 mit R4 (Pegel PPM)
- 3) 0 dB am Instrument mit R28
- 4) - 30 dB am Instrument mit R34
- 5) - 40 dB am Instrument mit R23

Calibration

- 1) Line level +6 ... +15 dB 1 kHz at input
- 2) +3.5 V at TP2, adjust with R4 (level PPM)
- 3) 0 dB at instrument adjust with R28
- 4) -30 dB at instrument adjust with R34
- 5) -40 dB at instrument adjust with R23

Die mechanische Nullstellung des Messwerkes liegt bei Referenzanzeige 0 dB. Für Pegel, deren Anzeige 0 ... + 6 dB ergibt, wechselt die Polarität der Ausgangsspannung am Verstärker 4.2.

The mechanical zero position of the instrument corresponds to the reference indication 0 dB. For levels which give a deflection of 0 ... +6 dB on the scale, the amplifier 4.2 changes the polarity of the output voltage.

TECHNISCHE DATEN

Eingangsempfindlichkeit für Referenzanzeige (0 dB):
 + 6 dBu ... + 15 dBu
 Eingangsimpedanz >10 kOhm

Anzeigebereich:
 - 40 dB ... + 6 dB

Genauigkeit bei 20° C, 1 kHz
 - 40 dB ... + 6 dB: ± 0,5 dB

Frequenzgang bei Referenzanzeige 0° C ... 50° C,
 31,5 Hz ... 15 kHz: ± 0,5 dB

Temperatureinfluss bei Referenzanzeige, 1 kHz,
 0° C ... 50° C: < Fehler 0,5 dB

Dynamisches Verhalten:

Überschwingen: ≤ 1 dB

Ansprechzeit auf
 - 1 dB + 0,5 dB: 10 ms
 - 4 dB ± 1 dB: 3 ms

Rücklaufzeit 0 ... - 20 dB: 1,7 s ± 0,3 s

Stromaufnahme bei ± 15 V: Ca 15 mA

MECHANISCHE DATEN

Frontplatte dunkelgrau gespritzt
 Abmessungen Frontplatte 170 x 80 mm
 Tiefe 135 mm
 Gewicht 360 gr

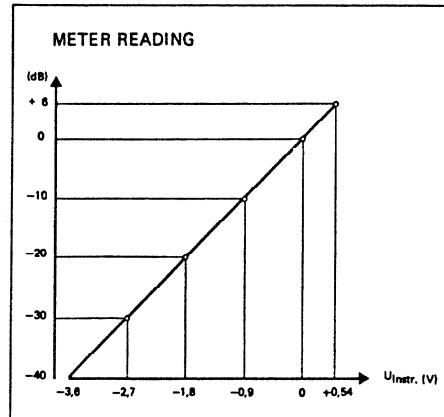

SPECIFICATIONS

Input sensitivity for reference indication (0 dB):
 +6 dBu ... +15 dBu
 Input impedance >10 kOhm

Indicating range
 -40 dB ... +6 dB

Accuracy at 20° C, 1 kHz
 -40 dB ... +6 dB: ± 0.5 dB

Frequency response at reference indication
 0° C ... 50° C
 31.5 Hz ... 15 kHz: ± 0.5 dB

Influence of temperature at reference indication,
 1 kHz 0° C ... 50° C: error 0.5 dB

Dynamic response:

Overswing: 1 dB

Attack time to
 -1 dB + 0.5 dB: 10 ms
 -4 dB ± 1 dB: 3 ms

Return time 0 ... -20 dB: 1.7 s ± 0.3 s

Connected load at ± 15 V: approx. 15 mA

PHYSICAL DATA

Front panel laquered charcoal grey
 Dimensions of front panel 170 x 80 mm
 Depth 135 mm
 Weight 360 g

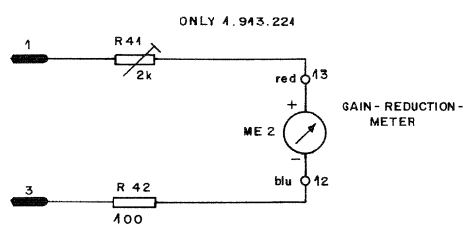
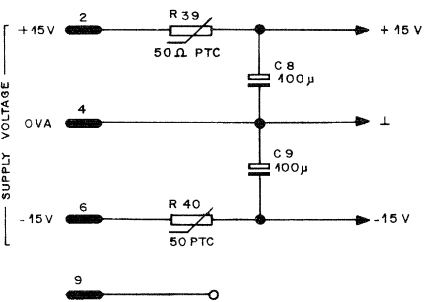
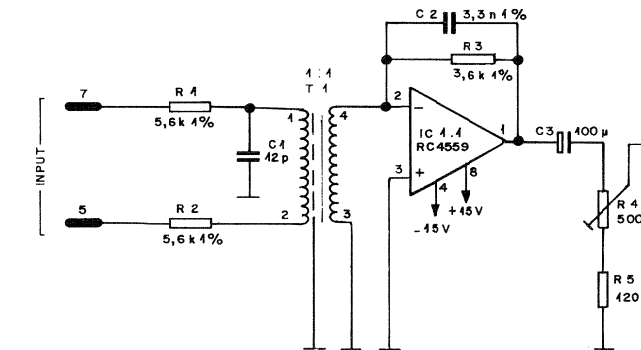
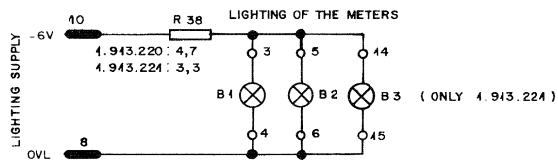

- ADJUSTMENT :**
- 3,5 V DC AT TP 2 - R 4
 - 0 dB AT ME 1 - R 28
 - 30 dB AT ME 1 - R 34
 - 40 dB AT ME 1 - R 23

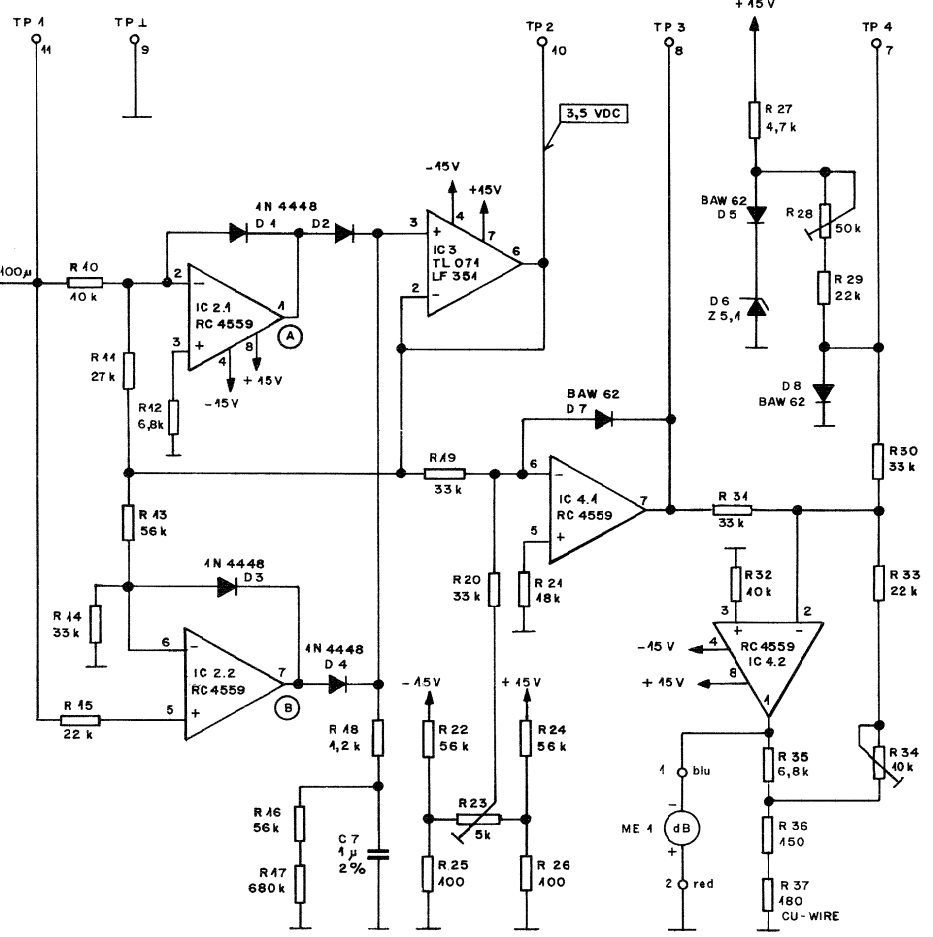
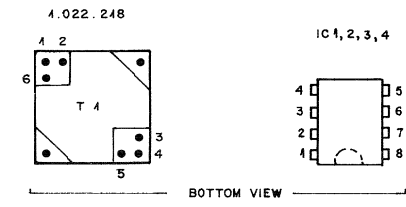
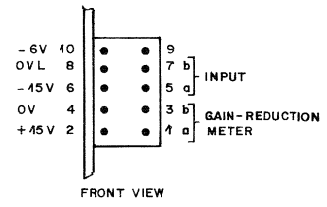

DATE	21.10.82		
SIGN	<i>Mly</i>		
REGENSCHEN REGENSDORF ZÜRICH	PEAK PROGRAMME METER	SC 1.913.220/221	

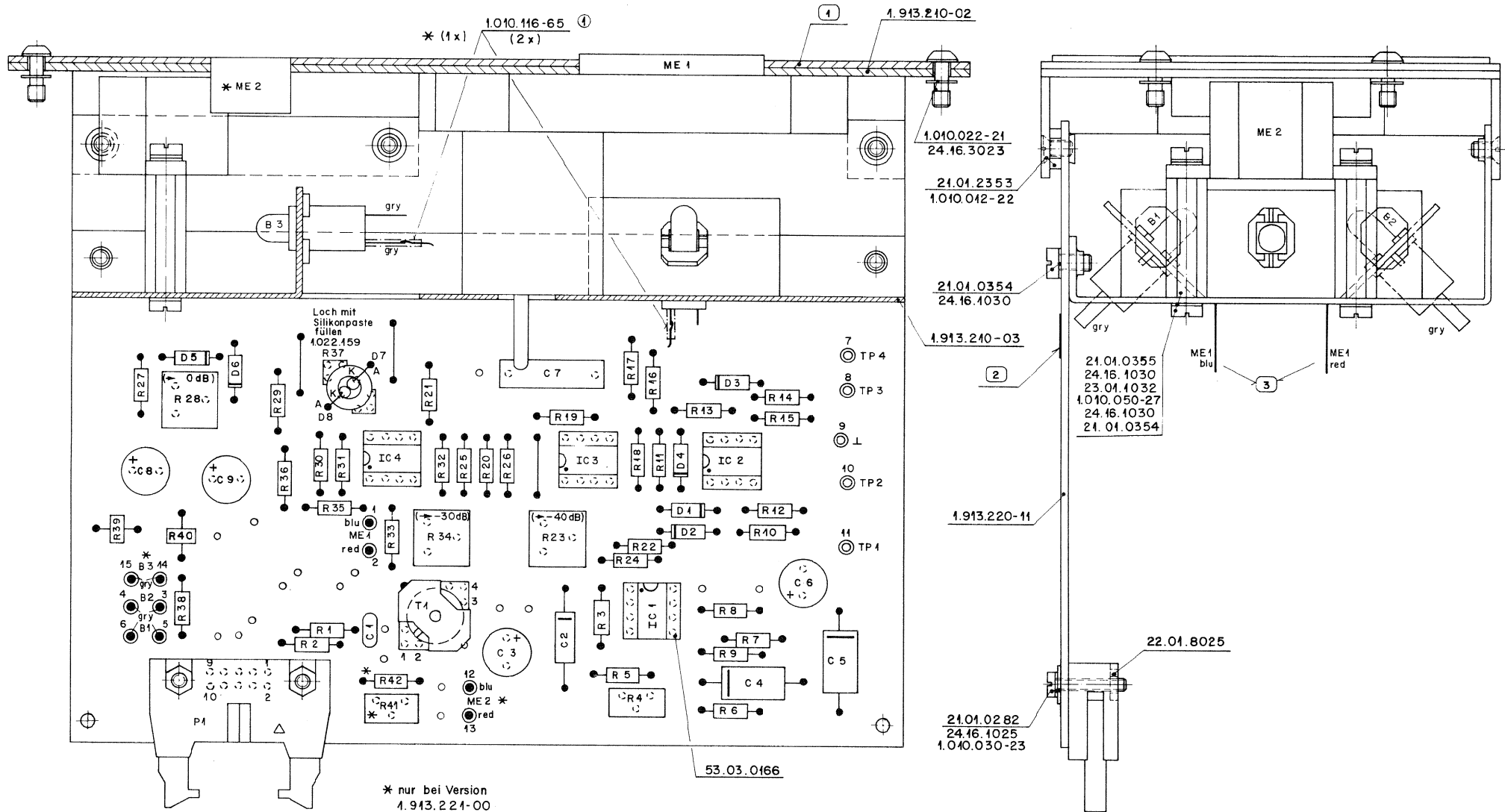

Gültig für :	1	2	3
1.913.220-00	1.913.210-01	1.913.220-04	1.913.210-93
1.913.221-00	1.913.221-01	1.913.221-04	1.913.221-93

Werkstoff Norm-Nr DIN-Bez.	Gute		Anmerkung
	Oberfläche Ben.		
Abmessung	10.12.84 A.Ho <i>MM</i> <i>VR</i>		Ausgabe Datum Gez Gepr Gcs Index
Zugehörige Unterlagen	Freimasstoleranz	Maßstab 2:1	
PL	11.2.83 A.Ho <i>MM</i> <i>VR</i>		Kopie für
Ersatz für:	Ersetzt durch:	Benennung Peak Programme Meter	
Studer REGENSDORF ZÜRICH		1.913.220-00	3 2 1

INDI	POS NO	PART NO	VALUE	SPECIFICATIONS/EQUIVALENT	MFR
	C1	59.34.1120	12pF	5%	
	C2	59.12.7332	3,3nF	1%	
	C3	59.22.5101	100μF	16V	
	C4	59.12.9102	1 nF	1%	
	C5	59.12.9102	1nF	1%	
	C6	59.22.5101	100μF	16V	
	C7	59.99.0508	1 μF	2%	
	C8	59.22.5101	100μF	16V	
	C9	59.22.5101	100μF	16V	
	D1	50.04.0125	1N4448		any
	D2	50.04.0125	1N4448		any
	D3	50.04.0125	1N4448		any
	D4	50.04.0125	1N4448		any
	D5	50.04.0132	BAW62		only PH
	D6	50.04.1112	ZPD 5,1	5,1V at 5mA, 5%	ITT
	D7	50.04.0132	BAW62		only PH
	D8	50.04.0132	BAW62		only PH
	IC1	50.09.0107	RC4559NB		RA, TI
	IC2	50.09.0107	RC4559NB		RA, TI
	IC3	50.09.0103	TL071CP	LF351N	TI, N
	IC4	50.09.0107	RC4559NB		RA, TI
	ME1	1.913.001.01		Peak Programme Meter	
	ME2	1.169.900.02		Gain-Reduction-Meter (only 1.913.221)	

INDI	DATE	NAME	
④			
③			
②			
①			
○	20-8-81	<i>NY</i>	also valid for PPM with gain reduction meter 1.913.221
STUDER	PEAK PROGRAMME METER	1.913.220	PAGE 1 OF 3

INDI	POS NO	PART NO	VALUE	SPECIFICATIONS/EQUIVALENT	MFR
	R1	57.11.3562	5,6k	1%	
	R2	57.11.3562	5,6k	1%	
	R3	57.11.3362	3,6k	1%	
	R4	58.01.7501	500	TRIM	
	R5	57.11.4121	120		
	R6	57.11.3752	7,5k	1%	
	R7	57.11.3912	9,1k	1%	
	R8	57.11.3152	1,5k	1%	
	R9	57.11.3102	1k	1%	
	R10	57.11.4103	10k		
	R11	57.11.4273	27k		
	R12	57.11.4682	6,8k		
	R13	57.11.4563	56k		
	R14	57.11.4333	33k		
	R15	57.11.4223	22k		
	R16	57.11.4563	56k		
	R17	57.11.4684	680k	2%	
	R18	57.11.4122	1,2k		
	R19	57.11.4333	33k		
	R20	57.11.4333	33k		
	R21	57.11.4183	18k		
	R22	57.11.4563	56k		
	R23	58.01.8502	5k	TRIM	
	R24	57.11.4563	56k		
	R25	57.11.4101	100		
	R26	57.11.4101	100		
	R27	57.11.4472	4,7k		
	R28	58.01.8503	50k	TRIM	
	R29	57.11.4223	22k		
	R30	57.11.4333	33k		

INDI	DATE	NAME	
④			
③			
②			
①			
○	20-8-81	<i>NY</i>	
STUDER	PEAK PROGRAMME METER	1.913.220	PAGE 2 OF 3

INDI	POS NO	PART NO	VALUE	SPECIFICATIONS/EQUIVALENT	MFR
	R31	57.11.4333	33k		
	R32	57.11.4103	10k		
	R33	57.11.4223	22k		
	R34	58.01.8103	10k	TRIM	
	R35	57.11.4682	6,8k		
	R36	57.11.4151	150		
	R37	1.022.159.00	180	Cu-Wire	STUDER
	R38	57.11.4479	47Ω	1.913.221 : 3,3Ω	
	R39	57.99.0206	50Ω	PTC	
	R40	57.99.0206	50Ω	PTC	
	R41	58.01.7202	2k	TRIM only 1.913.221	
	R42	57.11.4101	100	only 1.913.221	
	T1	1.022.218.00	1:1	Input Trafo	STUDER
	B1	51.02.0144	6V, 30mA	Lamp	
	B2	51.02.0144	6V, 30mA	Lamp	
	B3	51.02.0144	6V, 30mA	Lamp	
	P1	54.14.2011		Connector	
	X1C	53.03.0166		IC-Socket 8pins	

INDI	DATE	NAME	
④			
③			
②			
①			
○	20-8-81	<i>NY</i>	
STUDER	PEAK PROGRAMME METER	1.913.220	PAGE 3 OF 3

VU-METER

VU-Meter mit symmetrisch, erdfreiem und hoch-ohmigem Eingang. Dynamische Daten gemäss IEC.

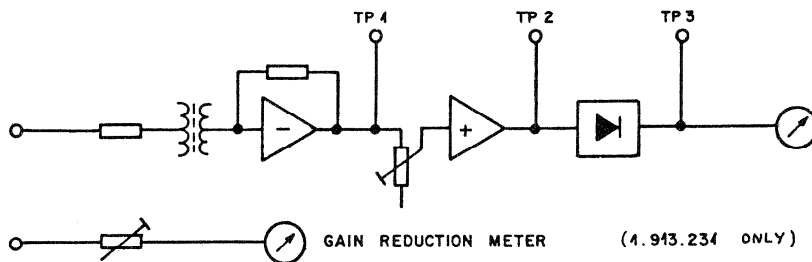
BlockschaltbildEinmessen:

TP1: Variabel (0,1 V ... 0,35 Veff)

TP2: 1 Veff

TP3: - 3,6 V p Vollweg-Gleichrichtung

Mit R4 kann die Referenzanzeige (0 VU) für Eingangssignale zwischen 0 dBu und +10 dBu eingestellt werden.

Calibration

TP1: Variable (0.1 V ... 0.35 Veff)

TP2: 1 Veff

TP3: -3.6V p full-wave rectification

The reference indication (0 VU) for input signals between 0 dBu and +10 dBu can be adjusted with R4.

VU-Meter

VU-meter with balanced, floating and high-impedance input. Dynamic response according to IEC.

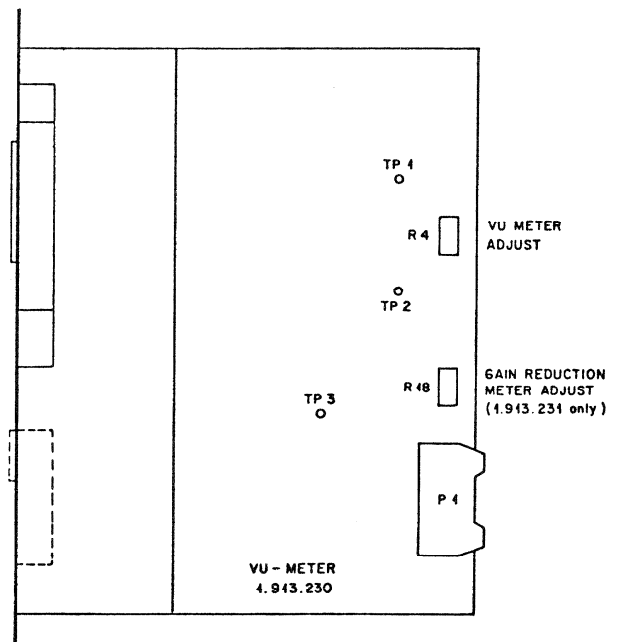
Block diagramTECHNISCHE DATEN

Eingangsempfindlichkeit für Referenzanzeige (0 VU)	0 dBu ... +10 dBu
Eingangsimpedanz	> 10 kOhm
Anzeigebereich	- 20 VU ... + 3 VU
Genauigkeit bei 20°C, 1 kHz, -10 VU ... +3 VU	± 0,5 VU
Frequenzgang für Referenzanzeige 0°C ... 50°C, 31,5 Hz ... 15 kHz	± 0,5 VU
Ansprechzeit auf -1 VU	207 ms ± 30 ms
Speisung	+ 15 V 10 mA - 15 V 10 mA - 6 V 60 mA (90 mA)

MECHANISCHE DATEN

Frontplatte dunkelgrau gespritzt	
Abmessungen Frontplatte	170 x 80 mm
Tiefe	135 mm
Gewicht	310 gr

SPECIFICATIONS

Input sensitivity for reference indication (0 VU)	0 dBu ... +10 dBu
Input impedance	>10 kOhm
Indicating range	-20 VU ... + 3 VU
Accuracy at 20°C, 1 kHz, -10 VU ... +3 VU	±0.5 VU
Frequency response for reference 0°C ... 50°C, 31.5 Hz ... 15 kHz	±0.5 VU
Attack time to -1 VU	207 ms ±30 ms
Supply	+15 V 10mA -15 V 10mA - 6 V 60mA (90mA)

PHYSICAL DATA

Front panel sprayed charcoal grey	
Dimension of front panel	170 x 80mm
Depth	135mm
Weight	310 g

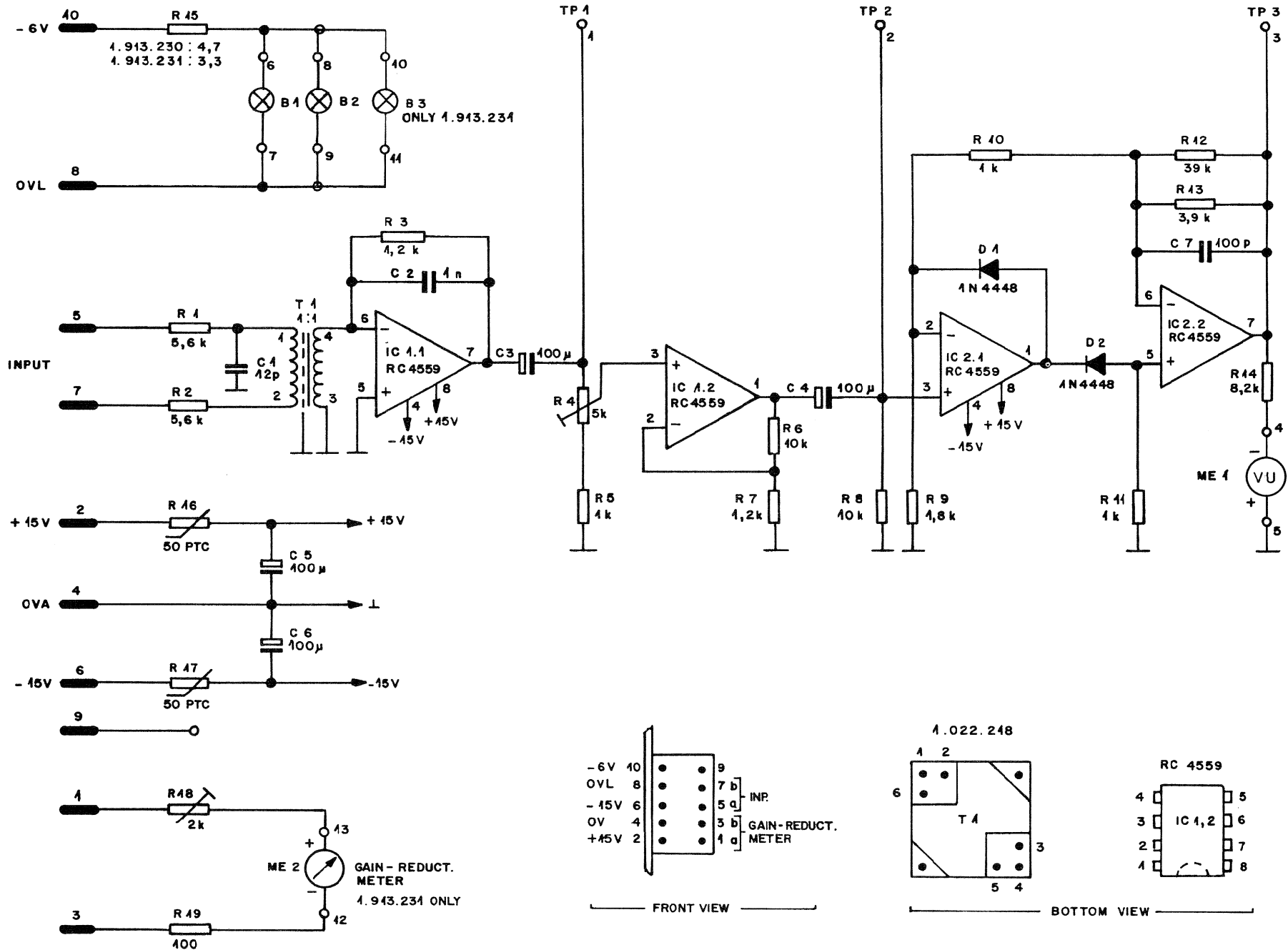

DATE:	10.10.88	0.1.89				
SIGN:	<i>[Signature]</i>	<i>[Signature]</i>				
STUDEF REGENSDORF ZÜRICH			VU-METER			SC 1.913.230/231

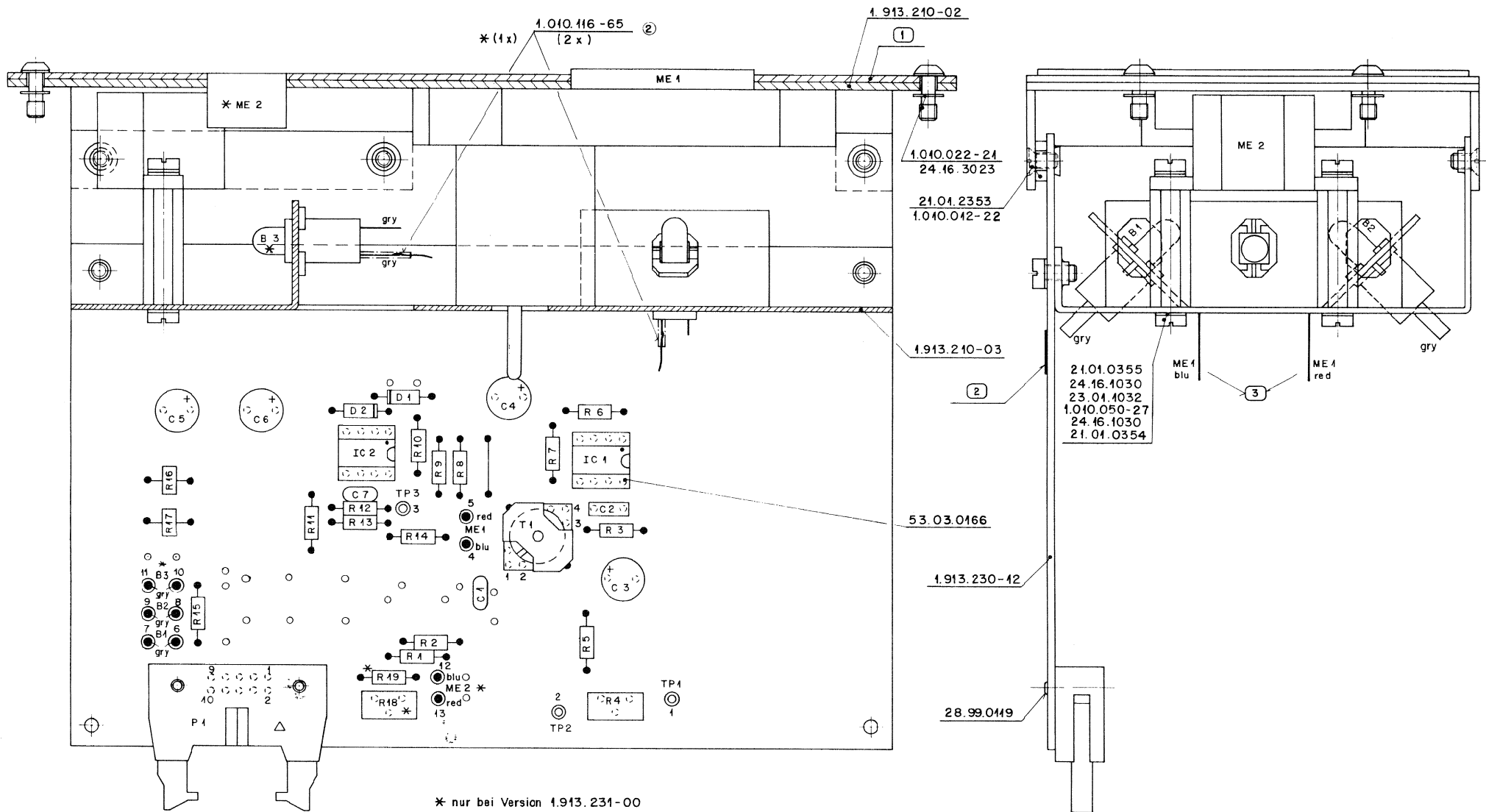

Gültig für :	①	②	③
1.913.230-00	1.913.210-01	1.913.230-04	1.913.210-93
1.913.231-00	1.913.221-01	1.913.231-04	1.913.221-93

Weisstoff	Norm-Nr.:					Änderung	③
	DIN-Bez.:						②
	Abmessung:						①
Zugehörige Unterlagen:		Freimasstoleranz:	Maßstab:	Ausgabe			④
PL		+	2:1	Datum			Gez. Gepr. Ges. Index
Ersatz für:		Ersetzt durch:		Kopie für:			
STUDER REGENSDORF ZÜRICH		Benennung: VU-Meter		Nummer: 1.913.230-00			

INDI	POS NO	PART NO	VALUE	SPECIFICATIONS/EQUIVALENT	MFR
	C1	59.34.1120	12 pF	5%	
	C2	59.06.0102	1 nF	10%	
	C3	59.22.5101	100 μ F	$\geq 16V$	
	C4	59.22.5101	100 μ F	$\geq 16V$	
	C5	59.22.5101	100 μ F	$\geq 16V$	
	C6	59.22.5101	100 μ F	$\geq 16V$	
	C7	59.34.4101	100 pF	5%	
	D1	50.04.0125	1N4448		any
	D2	50.04.0125	1N4448		any
	IC1	50.09.0107	RC4559NB	Dual OP AMP	Ro, TI
	IC2	50.09.0107	RC4559NB	Dual OP AMP	Ro, TI
	R1	57.11.3562	5.6 k	1%	
	R2	57.11.3562	5.6 k	1%	
	R3	57.11.4122	12k		
	R4	58.01.7502	5k	TRIM-POTM.	
	R5	57.11.4102	1k		
	R6	57.11.4103	10k		
	R7	57.11.4122	12k		
	R8	57.11.4103	10k		
	R9	57.11.4182	18k		
	R10	57.11.4102	1k		
	R11	57.11.4102	1k		
	R12	57.11.4393	39k		
	R13	57.11.4392	39k		
	R14	57.11.4822	8.2k		

INDI	DATE	NAME		
④			Ro Raytheon	
③			TI Texas Instr.	
②			also valid for VU-meter with	
①			gain reduction meter 1.913.231	
○	20-8-81	<i>MJ</i>		
STUDER		VU-METER	1.913.230	PAGE 1 OF 2

INDI	POS NO	PART NO	VALUE	SPECIFICATIONS/EQUIVALENT	MFR
	R15	57.11.4479	47 Ω	1.913.231: 3,3 Ω (57.11.4339)	
	R16	57.99.0206	50	PTC PHILIPS 2.322.661.91002	
	R17	57.99.0206	50	PTC PHILIPS 2.322.661.91002	
	R18	58.01.7202	2k	Trim-Pot. (only 1.913.231)	
	R19	57.11.4101	100	(only 1.913.231)	
	T1	1.022.218.00	1:1	Input Trafo	
	B1	51.02.0144	6V, 30mA	Lamp	
	B2	51.02.0144	6V, 30mA	Lamp	
	ME1	1.913.001.02		VU-Meter	
	ME2	1.169.900.02		Gain-Reduction Meter (only 1.913.231)	
	P1	54.14.2011		Connector 10 pins	
	X1C	53.03.0166		IC-Socket 8pins DIP	
	B3	51.02.0144	6V, 30mA	Lamp (only 1.913.231)	

INDI	DATE	NAME		
④				
③				
②			also valid for VU-meter with	
①			gain reduction meter 1.913.231	
○	20-8-81	<i>MJ</i>		
STUDER		VU-METER	1.913.230	PAGE 2 OF 2

SECTION 7: Modular Sub Cards

1.914 ...

INHALT

MSC – Mother Board	1.915.770.00
* Line Output Amplifier	1.914.501.00
* High Level Input Amplifier	1.914.502.00...504.00
* Loudspeaker Amplifier	1.914.505.00
* Microphone Pre-Amp. for dynamic mic.	1.914.506.81
* Microphone Pre-Amp. for electret	1.914.507.81
* Voltage contr. amp., balanced in-/output	1.914.515.00
* Voltage controlled Amplifiers (VCA).....	1.914.518.00
* Limiter Voltage Proc.	1.914.519.81
* 1900 Hz Signal Generator + Decoder.....	1.914.520.00...522.00
* Relay Sub-Card	1.914.523.00...526.00
* VCA, 3 kontr. Eingänge	1.914.528.00
* (Breadboarding Card)=Experimental Board.....	1.914.529.00
* Zero-Ohm-Input Amp. with PFL	1.914.530.00
* High Level Input Amp. with PFL	1.914.531.00
* Flip-Flop.....	1.914.532.00
* 90° Filter stereo/mono.....	1.914.533.00
* Dual Vox Detector.....	1.914.534.00
* Tel Trafo Unit.....	1.914.536.00
* Mic Amp.with Limiter (TB)	1.914.539.00
* VCA control voltage IF	1.914.540.00

* Diese Beschreibungen werden kundenspezifisch bestückt.

* These descriptions are supplied according to the customers requirements.

MSC System

1.914....

Die Planung professioneller Tonstudioanlagen erfordert Komponenten von höchster Flexibilität. STUDER Ingenieure haben ein völlig neuartiges Konzept entwickelt.

Die Europakarte ist bezüglich Grösse und Anschlüsse eine verbreitete Platinen-norm. Viele Schaltungen nutzen jedoch nur einen kleinen Teil dieser Karte aus. Daraus entstand die Idee, die Europakarte nur als Träger für kleinere Schaltungen einzusetzen, die frei kombiniert werden können. Die so entstandene Trägerkarte (Mother Board) kann vier Subkarten (Modular Sub Cards) aufnehmen.

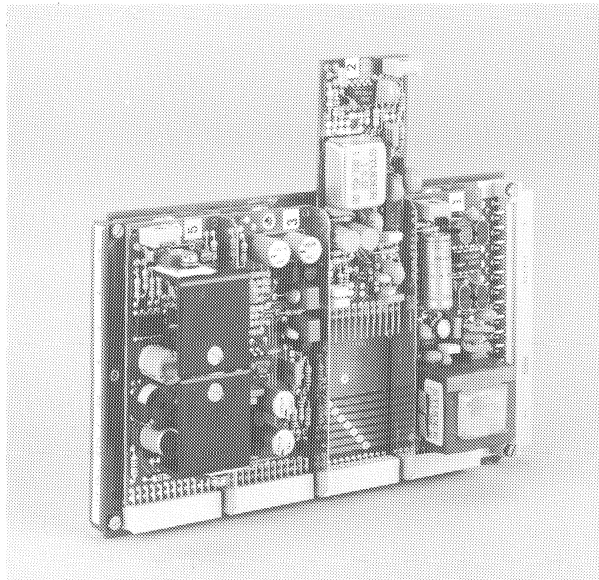

Die modularen Subkarten MSC sind in reicher Vielfalt lieferbar:

- Mikrophon Vorverstärker
- Lautsprecher Verstärker
- $O\Omega$ -Verstärker
- Limiter
- VCA
- VCA-Steuerspannungsinterface
- Relaiskarten
- Hochpegel-Eingangsverstärker
- Leitungsausgangs-Verstärker
- Signalgenerator / Decoder 1900Hz
- 90° Filter Stereo / Mono
- Flip-Flop
- Experimentierkarte

Bei der Projektierung können spezifische Systemanforderungen im Baukasten-system umgesetzt werden. Zur Verfügung stehen sowohl ein Sortiment an Standard-Europakarten als auch das flexible MSC-System, das den Aufbau individueller Europakarten ermöglicht.

Eine detaillierte Beschreibung der Europakarten und MSC gibt die Broschüre "STUDER Audio Components" (Best. Nr. 10.26.0104).

MSC – Mother Board

Die 'Modular Sub Cards' werden auf einer Trägerplatine frei kombiniert. Dieses 'Mother Board' im Europakartenformat gliedert sich nahtlos ins Programm der STUDER Audiokomponenten ein.

Die Trägerplatine kann vier Subkarten über je einen 13-poligen Winkelstecker und eine Befestigungsschraube aufnehmen. Alle vier Steckplätze sind über gedruckte Leiterbahnen mit dem 32-poligen Printstecker verbunden. Sechs gemeinsame Verbindungen liefern die Versorgungsspannungen, weitere sechs Leitungen stehen für jede Subkarte individuell zur Verfügung. Die restlichen beiden Bahnen bilden je eine getrennte Busverbindung zu den Steckplätzen 1 + 2 bzw. 3 + 4.

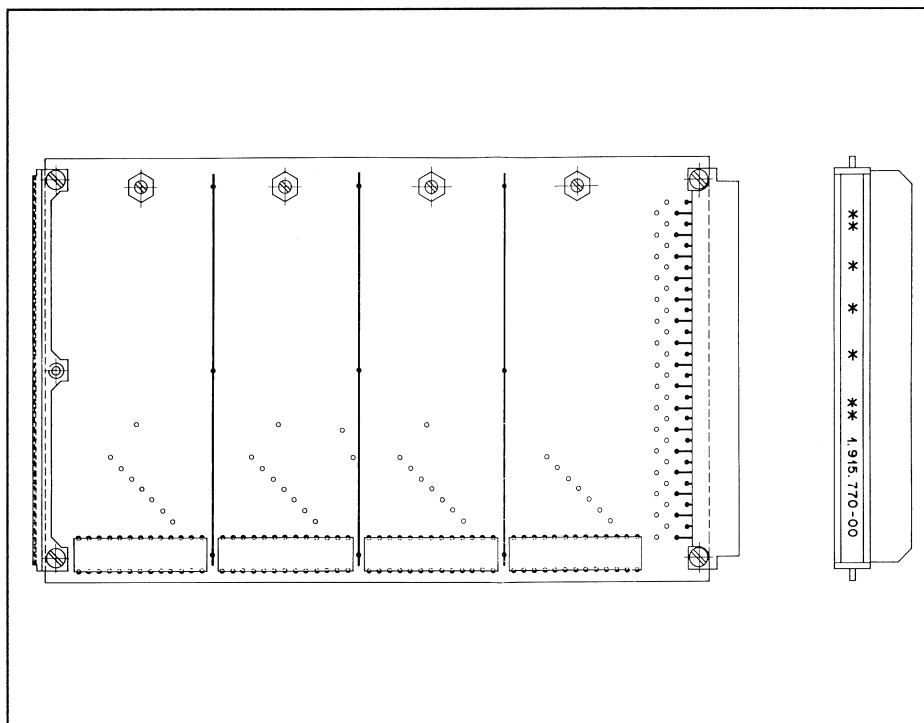
**Abmessungen**

Europakartenformat

100 x 160mm

Anschlüsse

1x EUROstecker 32-polig; DIN 41612;
4x CIS-Stecker 13-polig; (for MSC)

Bestellinformation

MSC Mother Board

1.915.770.00

MSC SYSTEM

MSC System

1.914....

To provide highest possible flexibility for the designer of professional sound systems, STUDER engineers have pursued a completely new concept.

The EURO-card is a convenient circuit board as far as its size and its plugin features are concerned, however, often it offers space in excess to that required for a particular circuit. This has triggered the idea to utilize the EURO-card simply as a carrier of smaller circuit boards that can be plugged onto the EURO-card, converting it into a master board that holds 4 small printed circuits - the "Modular Sub-Card" (MSC).

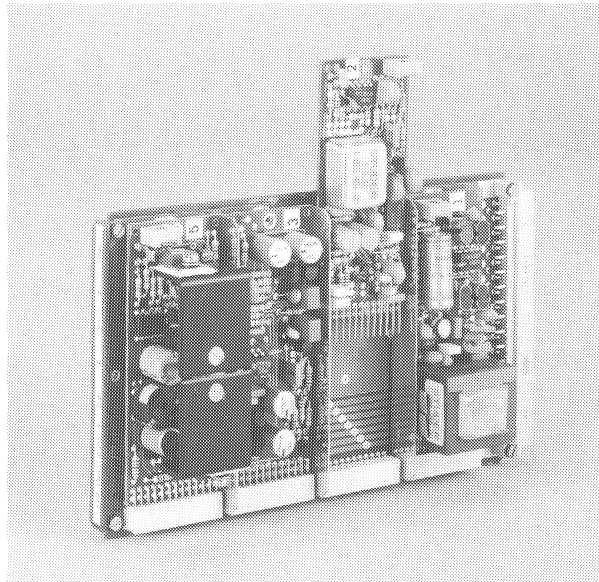

A great variety of different circuits is available in form of MSC's such as

- Microphone preamplifier
- Speaker amplifier
- O-Ohm amplifier
- Limiter
- Voltage controlled amplifier
- VCA control voltage interface
- Relay sub card
- High level input amplifier
- Line output amplifier
- Signal generator / decoder 1900Hz
- 90° filter stereo / mono
- Flip-Flop
- Experimental board

To meet the requirements of a system concept, a designer will be able to build up individual circuits similar to working with a constructions set: He either selects from the available circuits on EURO-cards or makes up his own EURO-card by simply arranging the most suitable combination of Modular Sub-Cards on the master card.

MSC - Mother Board

1.915.770

The Modular Sub-Cards require a Mother Board of the standard EURO-card size for integration into the STUDER audio components system. The Mother Board carries 32 printed tracks from its edge-connector to four small plug-in sockets. Each socket has 13 contacts of which six are common supply lines, while another six are individual to each socket. Then there is a separate busline for circuits 1 + 2 and another for 3 + 4.

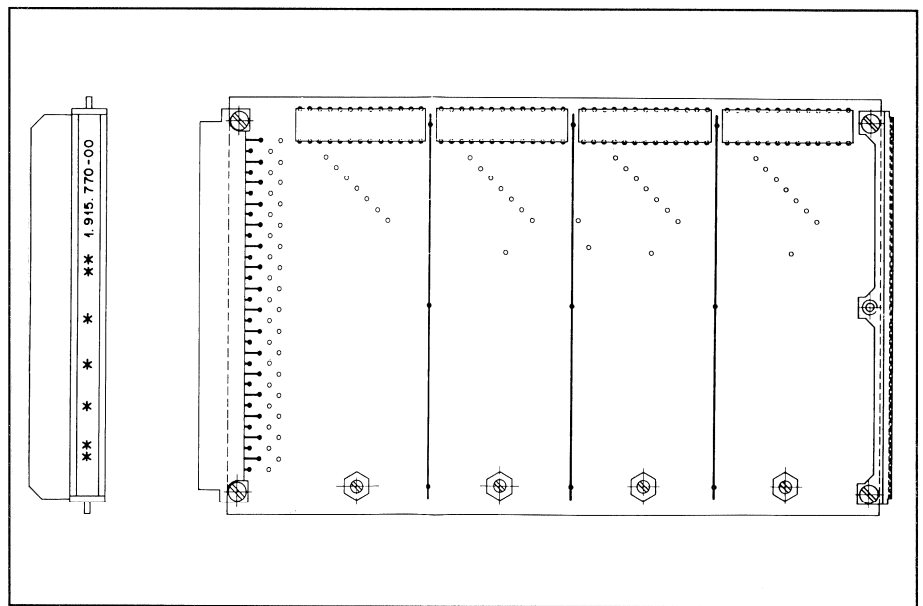
**Dimensions:**

EURO-card size

100 x 160mm

Connectors:

1x EURO connector

32 pin DIN 41'612

4x CIS connector

13 pin plug-in socket for MSC

Ordering InformationEURO-card:
MSC Mother Board

1.915.770.00

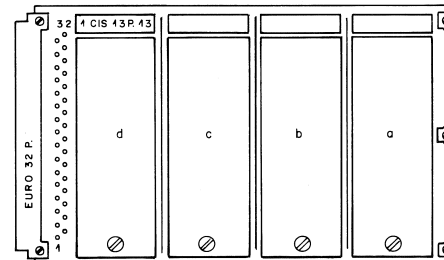
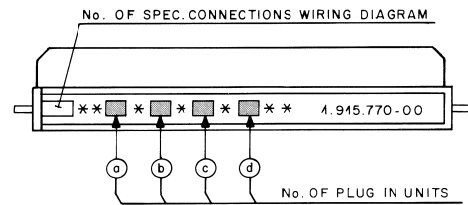
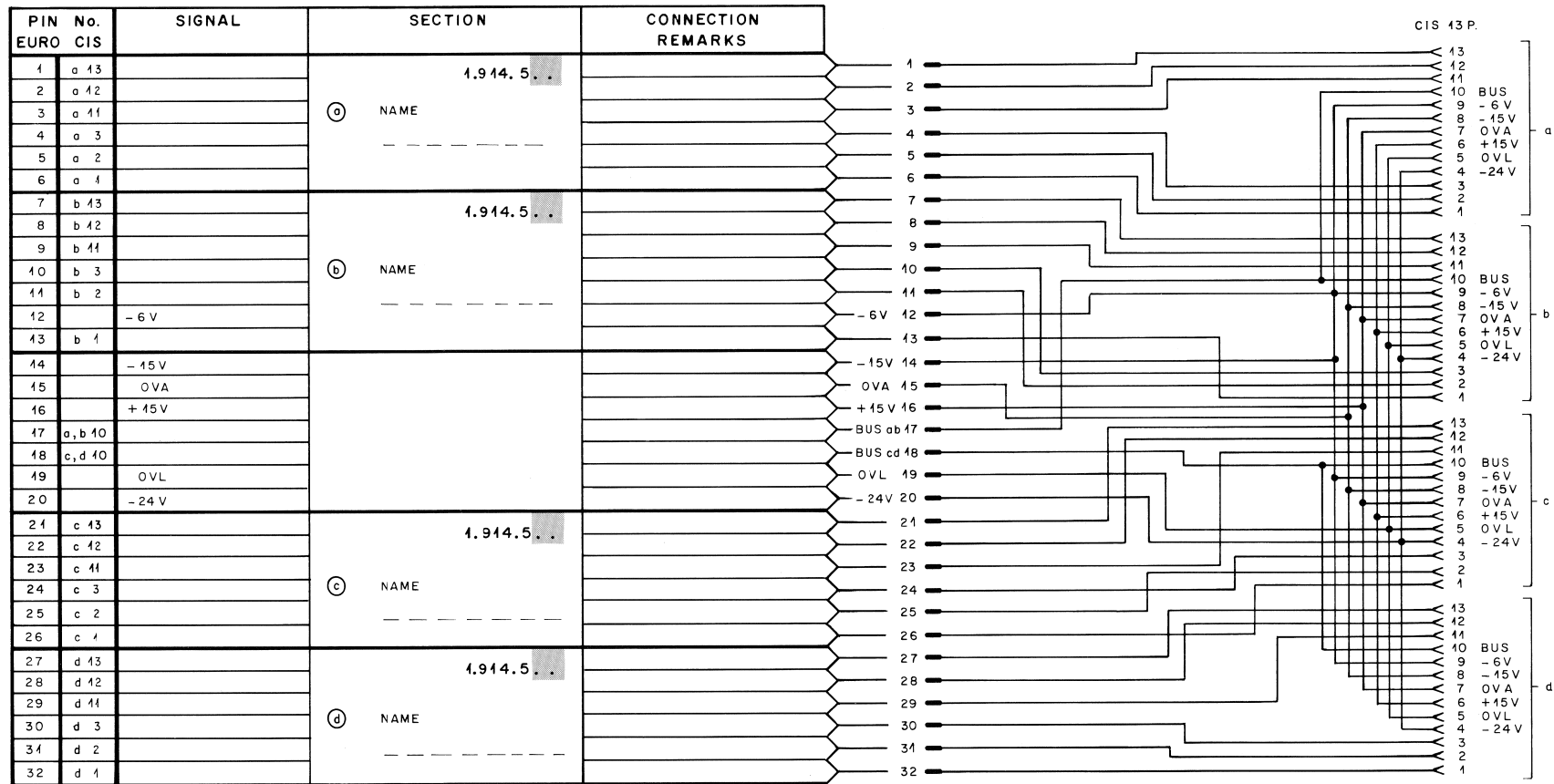

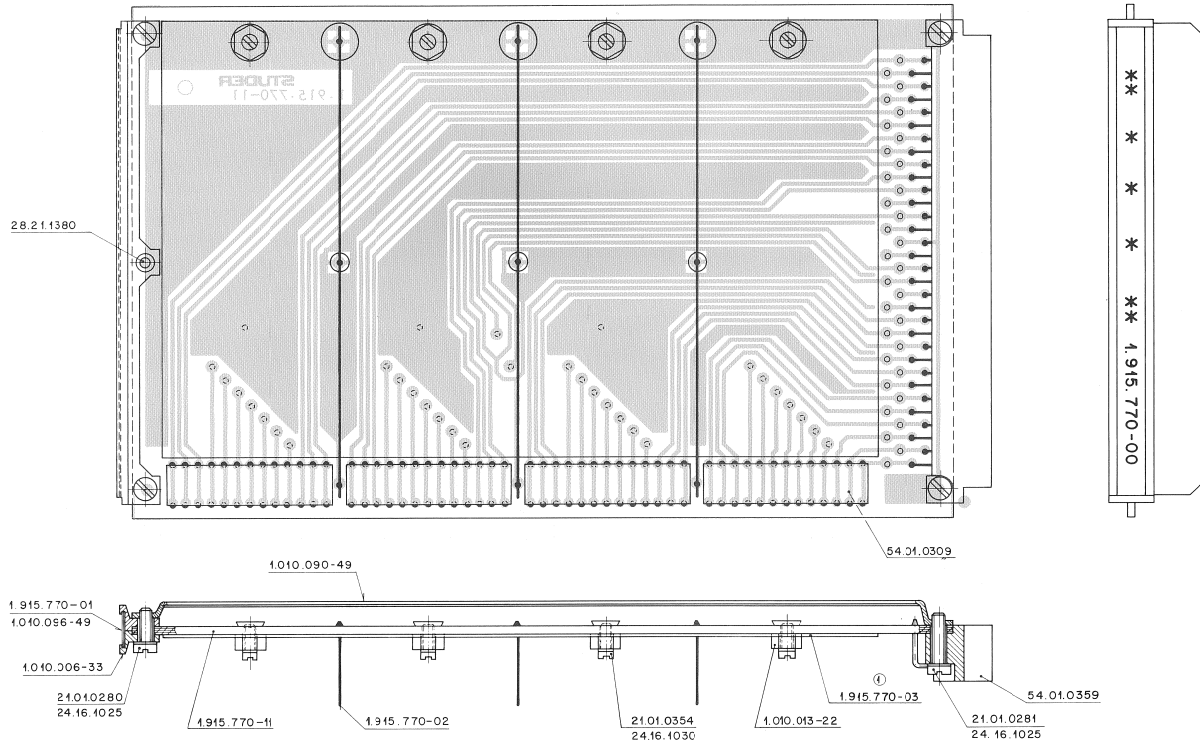

					①
					②
					③
					④
					⑤
					⑥
					⑦
					⑧
					⑨
					⑩

STUDER REGENSDORF ZÜRICH	Benennung	BASIS BOARD	Nummer	1.915.770-00			
				Datum	Gez	Gepr	Ges
			Kopie für				

KAPITEL 8: Europakarten und Stromversorgung 1.915 / 1.916. ...

INHALT

1.	Bestückungsansicht des Europakartenträgers	
2.	Transformer Block	1.910.5XX
3.	Stabilisator 5... 24V.....	1.915.106... 108
4.	Monitor Verstärker	1.915.304
5.	Monitor Relais	1.915.601
6.	Monitor Relais	1.915.602
7.	Signalisations-Relais	1.915.603
8.	Relais 8/1	1.915.605
	MSC Mother Board: siehe Kapitel 7.....	1.915.770
9.	Stereo-Symmetrierverstärker.....	1.915.904

Weitere kundenspezifisch ausgewählte Europakarten.

SECTION 8: EU standard PCB and Power Supply 1.915 / 1.916. ...

CONTENTS

1.	Layout of the Eurocard frame	
2.	Transformer block	1.910.5XX
3.	Stabilizer 5... 24V.....	1.915.106... 108
4.	Monitor amplifier	1.915.304
5.	Monitor relay	1.915.601
6.	Monitor relay	1.915.602
7.	Signalization relay	1.915.603
8.	Relay 8/1	1.915.605
	MSC mother board: see section 7	1.915.770
9.	Dual balancing amplifier	1.915.904

Further EU standard PCB's according to the specific customer requirements.

Trafoblock mit Gleichrichter 1.910.50X

Trafoblock mit Gleichrichter. Es bestehen zwei Grundausführungen:

- mit Netzschalter
- mit Netzrelais

1. Beschreibung

- Die Ausgangsspannungen sind programmierbar.
- Die Gleichrichter sind stark überdimensioniert.
- Die Sekundärseite ist mit 4 kV Prüfspannung von der Primärseite isoliert.
- Der Trafoblock ist allseitig geschlossen und liegt isoliert im Mischpult.
- Alle Primär- und Sekundärspannungen sind einzeln abgesichert.

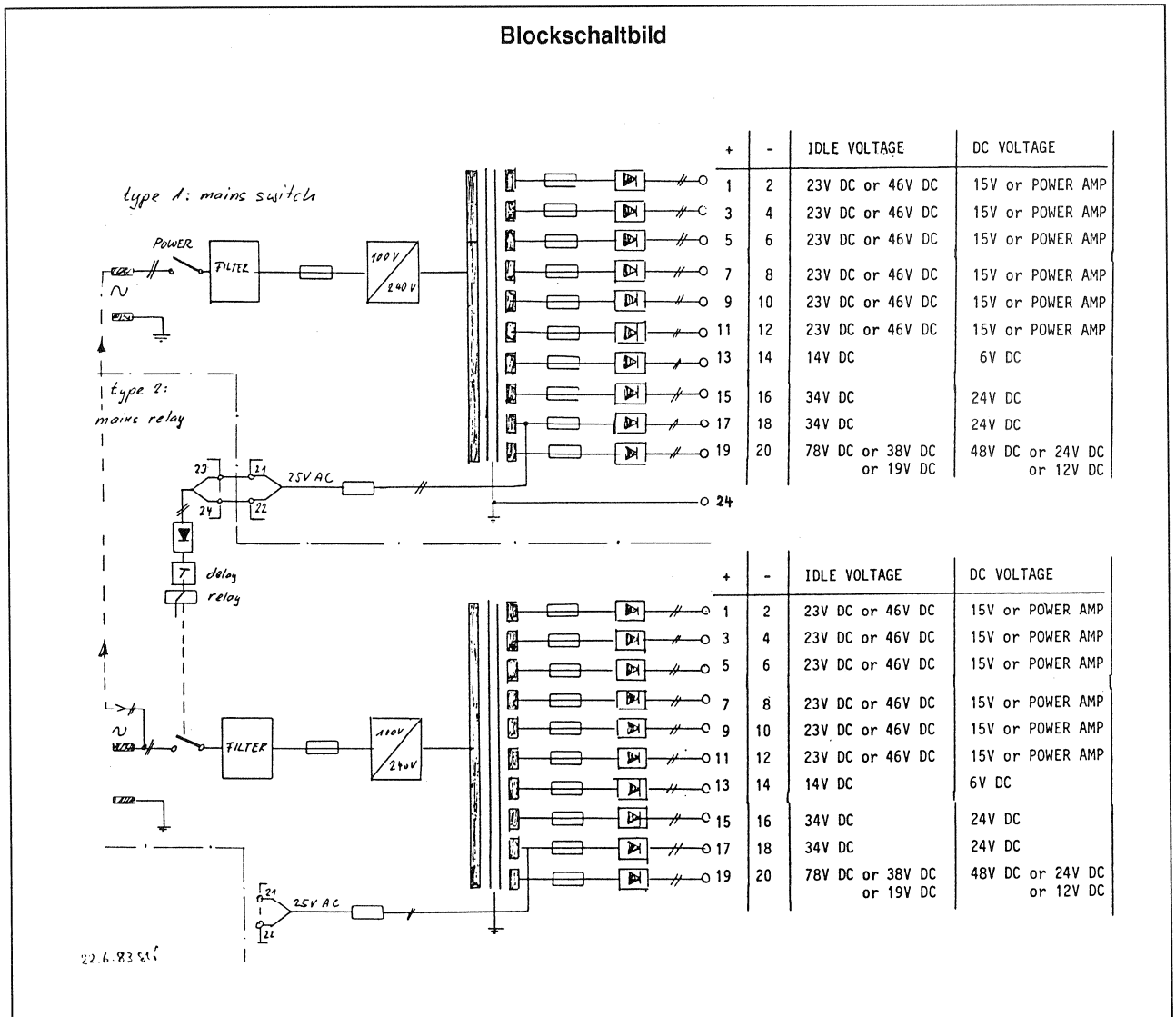

Fig. 1

2. Sicherheit

Der Trafoblock ist aufgebaut wie ein schutzisoliertes Gerät nach IEC 65, Klasse II. Als zusätzliche Sicherheit wird der **Erdeleiter** eingeführt. Der Trafoblock 1.910.50X ist im Mischpult isoliert eingebaut, so dass die Verbindung zwischen Schutzleiter und Mischpultgehäuse gefahrlos aufgetrennt werden kann.

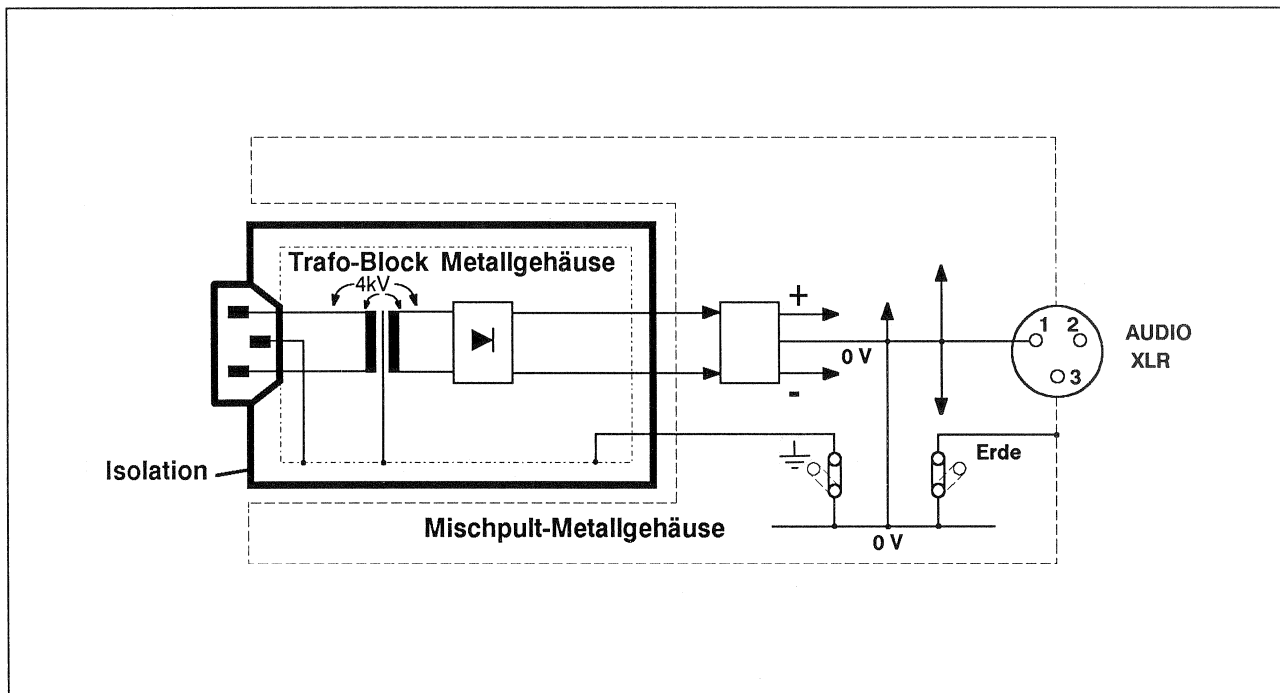

Fig. 2

3. Spezielle Daten

Siehe unter spezielle Datenblätter 1.910.500
 1.190.505

4. Mechanische Daten

Sekundär Buchse: 24P Molex

Gewicht: 9400 g

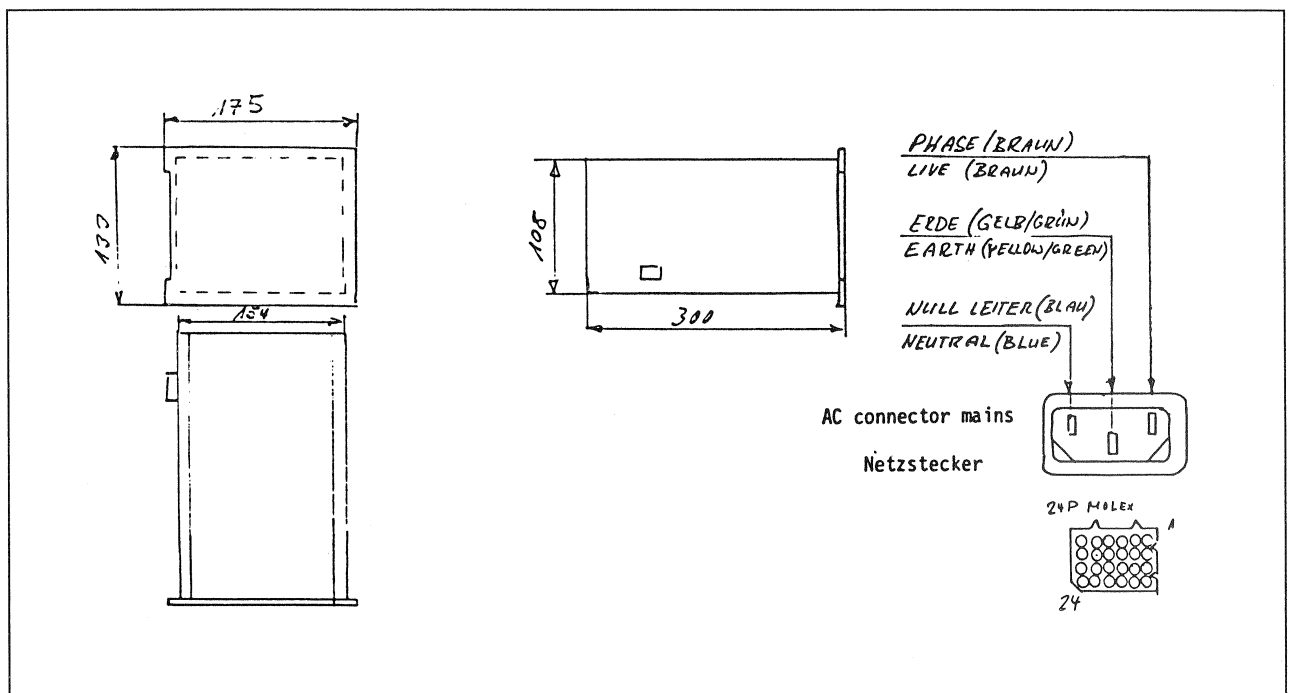

Fig. 3

Trafo Block 1.910.5XX

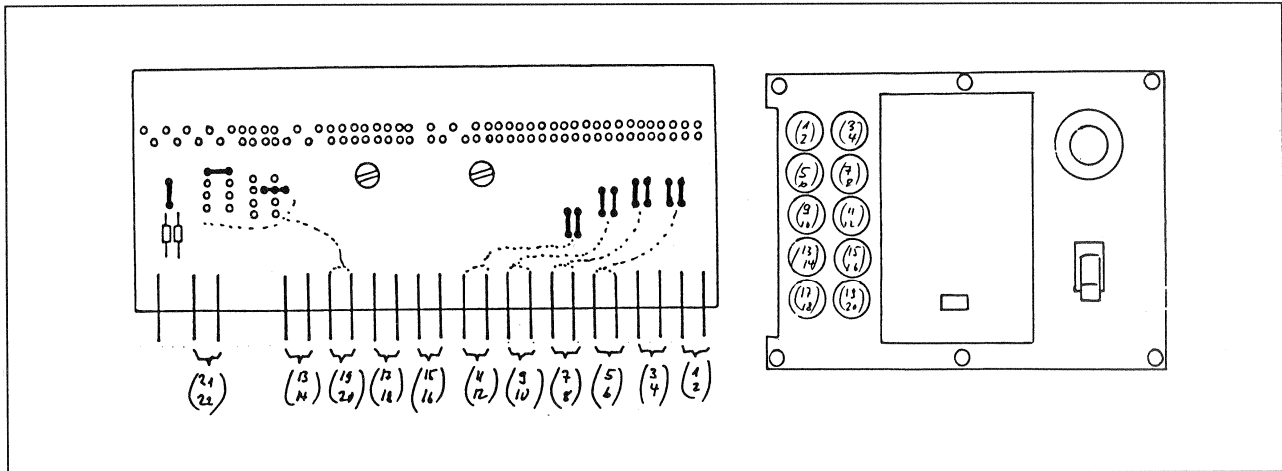

Fig. 4

TRAFO BLOCK			TRAFO BLOCK		
Grenzwerte:	Einzel max. Strom	Stabikarte Sicherung	Limiting values	SINGLE STABI max. current	PC FUSE
6V Wicklung (13)	4A	T 5A	6V winding (13)	4A	T 5A
(14)			6V winding (14)		
12V Wicklung	2,4A	T 5A	12V winding	2,4A	T 5A
24V Wicklung (19)			24V winding (19)		
(20)	1,2A	T 5A	(20)	1,2A	T 5A
48V Wicklung			48V winding		
15V Wicklung	0,6A	T 2A	15V winding	0,6A	T 2A
24V Wicklung	2,1A	T 5A	24V winding	2,1A	T 5A
40V Wicklung	1,2A	T 5A	40V winding	1,2A	T 5A
	1,2A	T 2A		1,2A	T 2A

Grenzwerte:	Doppel max. Strom	Stabikarte Sicherung	Limiting values	DUAL STABI max. current	PC FUSE	parallel schalten parallel connection					
6V Wicklung (13)	8A	2 x T 5A	6V winding (13)	8A	2 x T 5A	(1) (2)					
(14)			6V winding (14)								
12V Wicklung	5A	2 x T 4A	12V winding	5A	2 x T 4A		(3) (4)				
24V Wicklung (19)			24V winding (19)								
(20)	1,2A	T 5A	(20)	1,2A	T 5A			(5) (6)			
48V Wicklung			48V winding								
15V Wicklung	0,6A	T 2A	15V winding	0,6A	T 2A				(7) (8)		
24V Wicklung	2,1A	T 5A	24V winding	2,1A	T 5A					(9) (10)	
40V Wicklung	1,2A	T 5A	40V winding	1,2A	T 5A						(11) (12)
	1,2A	T 2A		1,2A	T 2A						

Fig. 5

Die maximale Belastung darf auf der gleichgerichteten Seite 350W nicht überschreiten.

Trafo - Block 1.910.500.81

1.910.500.81 1 x 6 V DC 2 x 24 V DC
 2 x 15 V DC
 4 x 40 V DC 1 x 48 V DC PHANTOM

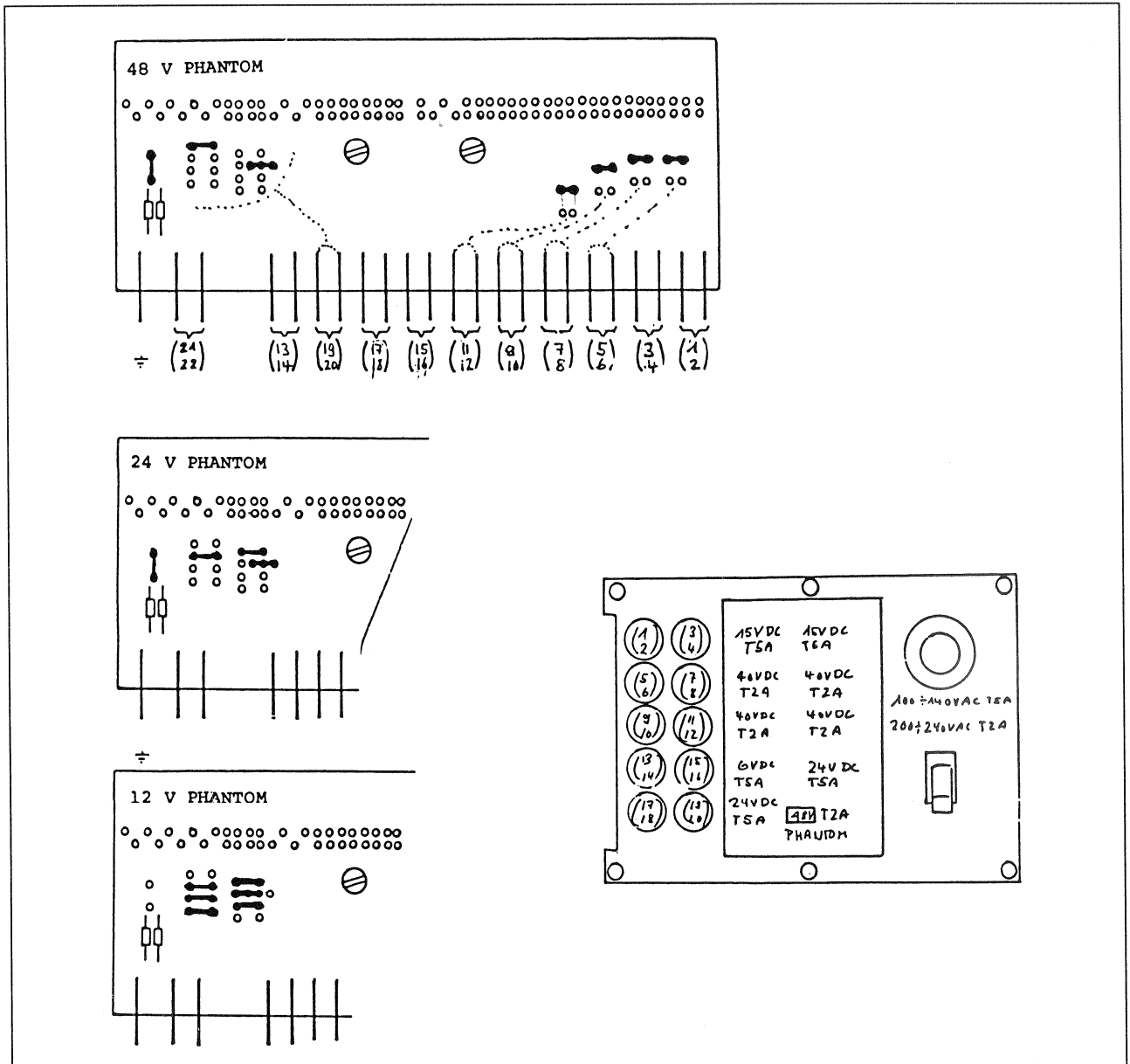

Fig. 6

Umbau auf andere Phantomspannungen

- Trafo-Block umbauen
- Widerstände auf dem Anschlussprint der Eingangseinheit ändern
 48V 6,8 kOhm/0,4 % 1.169.200.21
 24V 4,3 kOhm/0,4 % Entwurf IEC 268-15A
 12V 580 Ohm/0,4 % 1.169.200.20
- Stabilisatorkarte 1.915.107 Litze umstecken

Trafo-Block 1.910.505.81

1.910.505.81 1 x 6 V DC 2 x 24 V DC
 4 x 15 V DC
 2 x 40 V DC 1 x 48 V DC PHANTOM

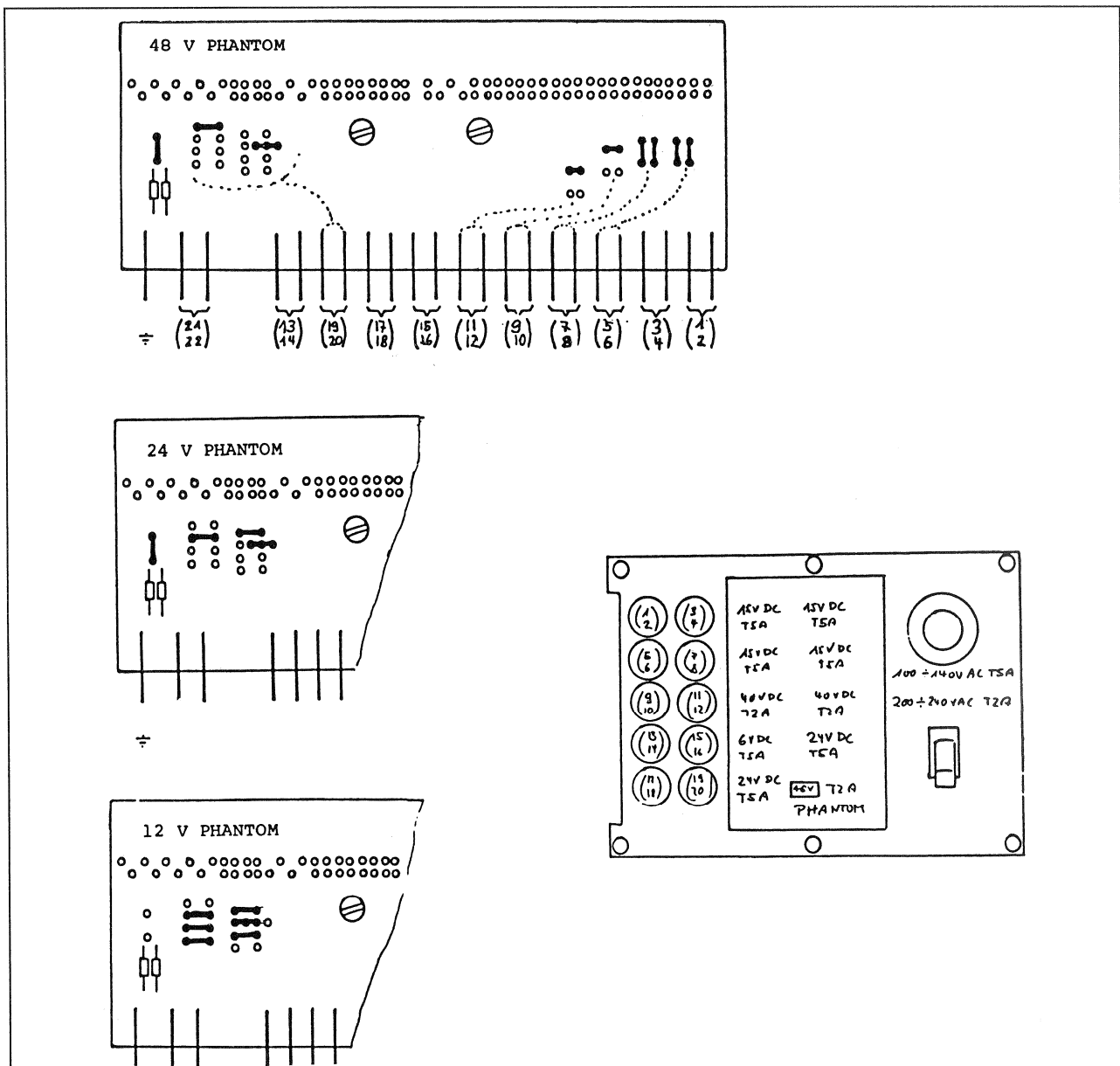

Fig. 6

Umbau auf andere Phantomspannungen

- Trafo-Block umbauen
- Widerstände auf dem Anschlussprint der Eingangseinheit ändern
 48V 6,8 kOhm/0,4 % 1.169.200.21
 24V 4,3 kOhm/0,4 % Entwurf IEC 268-15A
 12V 580 Ohm/0,4 % 1.169.200.20
- Stabilisatorkarte 1.915.107 Litze umstecken

Mains Trafo Block 1.910.50X

Trafo with rectifier. Two basic types are available:

- with mains switch
- with mains relay

1. Features

- Output voltages are programmable.
- Rectifiers are heavily oversized.
- Secondary windings are isolated by 4 kV against the primary side.
- The trafo-block is separately boxed and fixture by means of isolators.
- All voltages are protected by fuses individually.

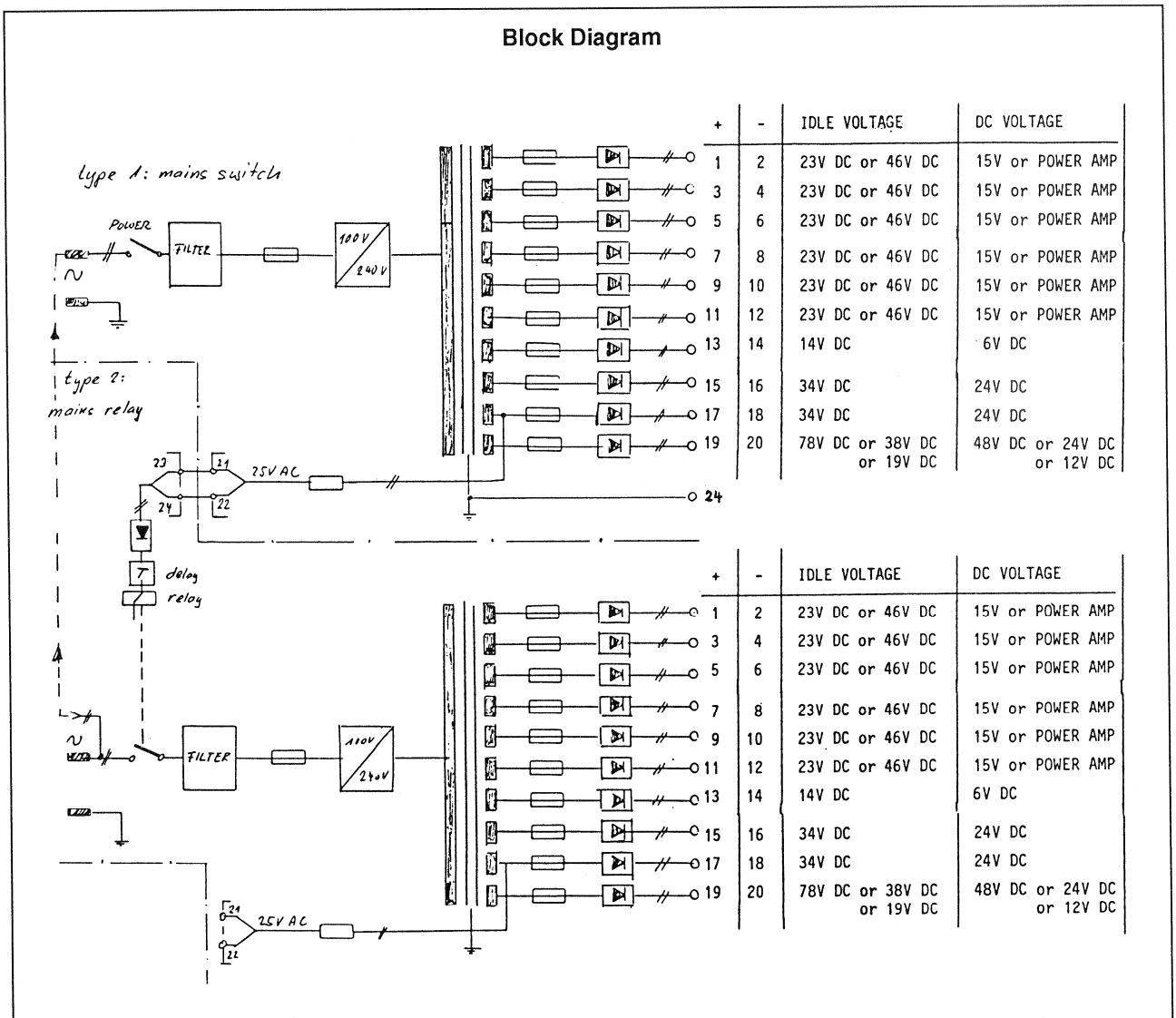

Fig. 1

2. Safety

The trafo-block is built like a double-isolated electric device (IEC 65 clause II). For improved safety, the connection to earth is also wired. In the mixer, the trafo-block 1.910.50X is built-in isolated. On the back side of the mixer the connection between earth and ground can be opened without the danger of an electric shock.

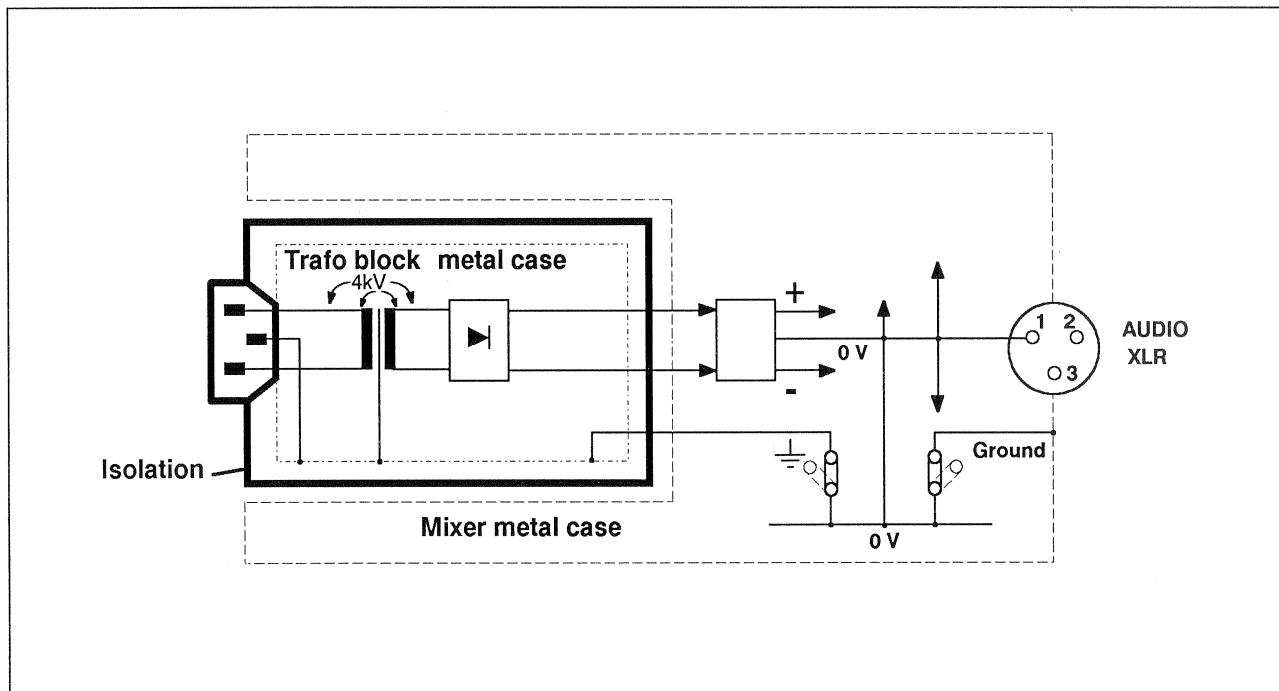

Fig. 2

3. Specifications

See special data sheet 1.910.500
 1.190.505

4. Dimensions

Secondary connector: 24P Molex

Weight: 9400 g

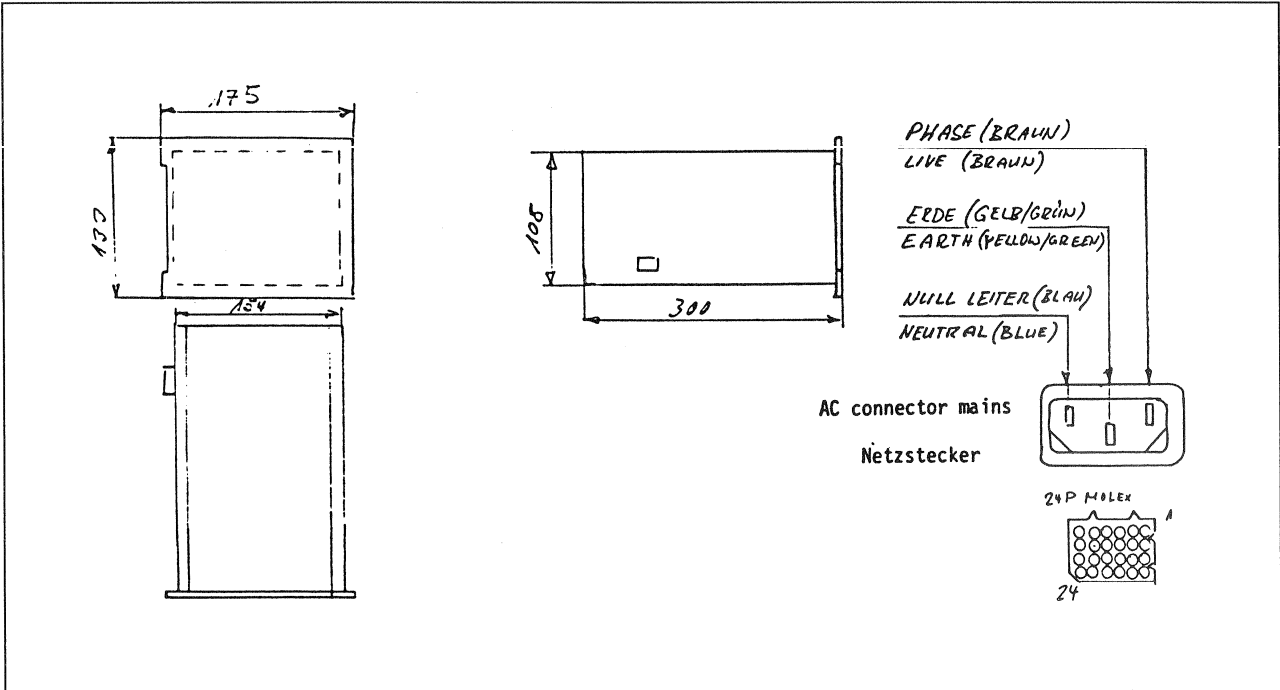

Fig. 3

Trafo Block 1.910.5XX

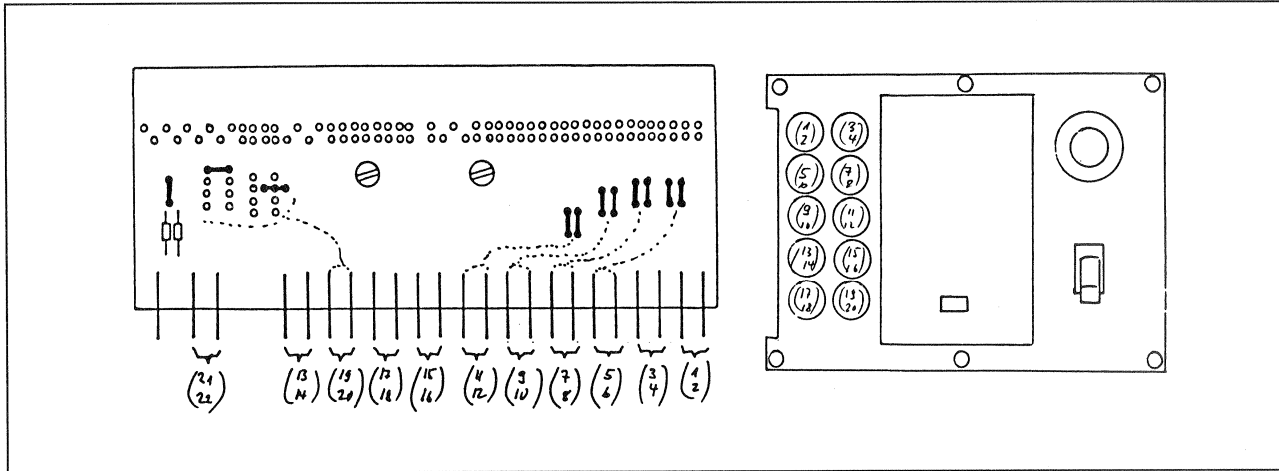

Fig. 4

TRAFO BLOCK			TRAFO BLOCK		
Grenzwerte:	Einzel Stabikarte		Limiting values	SINGLE STABI PC	
	max. Strom	Sicherung		max. current	FUSE
6V Wicklung (13) (14)	4A	T 5A	6V winding (13) (14)	4A	T 5A
12V Wicklung } (19)	2,4A	T 5A	12V winding } (19)	2,4A	T 5A
24V Wicklung } (20)	1,2A	T 5A	24V winding } (20)	1,2A	T 5A
48V Wicklung	0,6A	T 2A	48V winding	0,6A	T 2A
15V Wicklung	2,1A	T 5A	15V winding	2,1A	T 5A
24V Wicklung	1,2A	T 5A	24V winding	1,2A	T 5A
40V Wicklung	1,2A	T 2A	40V winding	1,2A	T 2A

Grenzwerte:	Doppel Stabikarte		Limiting values	DUAL STABI PC		parallel schalten parallel connection
	max. Strom	Sicherung		max. current	FUSE	
6V Wicklung (13) (14)	8A	2 x T 5A	6V winding (13) (14)	8A	2 x T 5A	
12V Wicklung } (19)	5A	2 x T 4A	12V winding } (19)	5A	2 x T 4A	
24V Wicklung } (20)			24V winding } (20)			
48V Wicklung			48V winding			
15V Wicklung	4-5 A	2 x T 4A	15V winding	4-5A	2 x T 4A	(1)(2)(3)(4)/(5)(6)(7)(8)/(9)(10)(11)(12)
24V Wicklung	2,5 A	-	24V winding	2,5A	-	
40V Wicklung	-	-	40V winding	-	-	

Fig. 5

The maximum load should not exceed 350 W on the rectifier side.

Trafo - Block 1.910.500.81

1.910.500.81 1 x 6 V DC 2 x 24 V DC
 2 x 15 V DC
 4 x 40 V DC 1 x 48 V DC PHANTOM

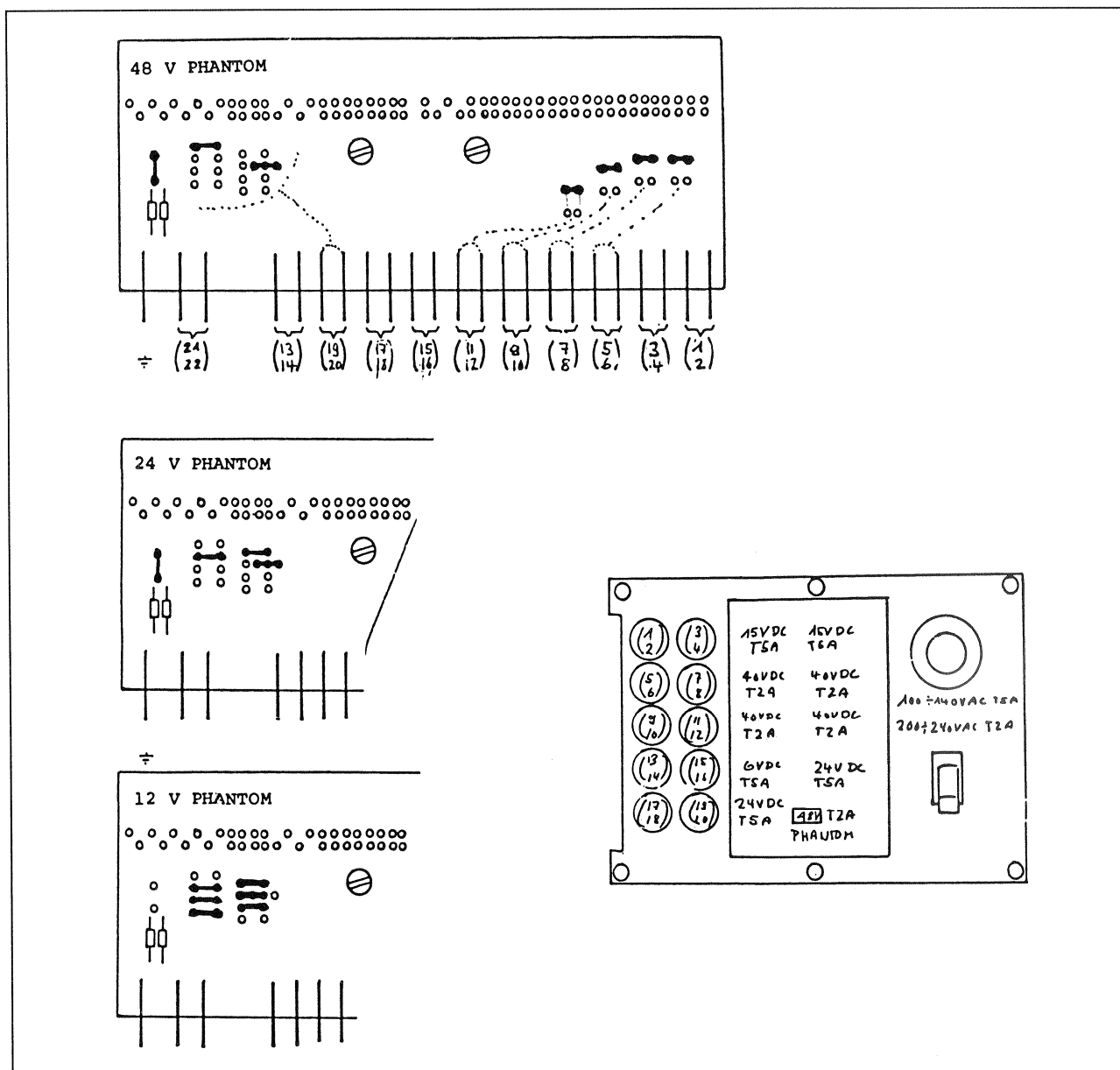

Fig. 6

Conversion of phantom powering

- Convert trafo-block
- Change resistor on the connection PCB of the input unit
 - 48V 6,8 kOhm/0,4 % 1.169.200.21
 - 24V 4,3 kOhm/0,4 % Draft IEC 268-15A
 - 12V 580 Ohm/0,4 % 1.169.200.20
- Reconnect the stranded wire on the stabilizer PCB 1.915.107

Trafo-Block 1.910.505.81

1.910.505.81	1 x 6 V DC	2 x 24 V DC
	4 x 15 V DC	
	2 x 40 V DC	1 x 48 V DC PHANTOM

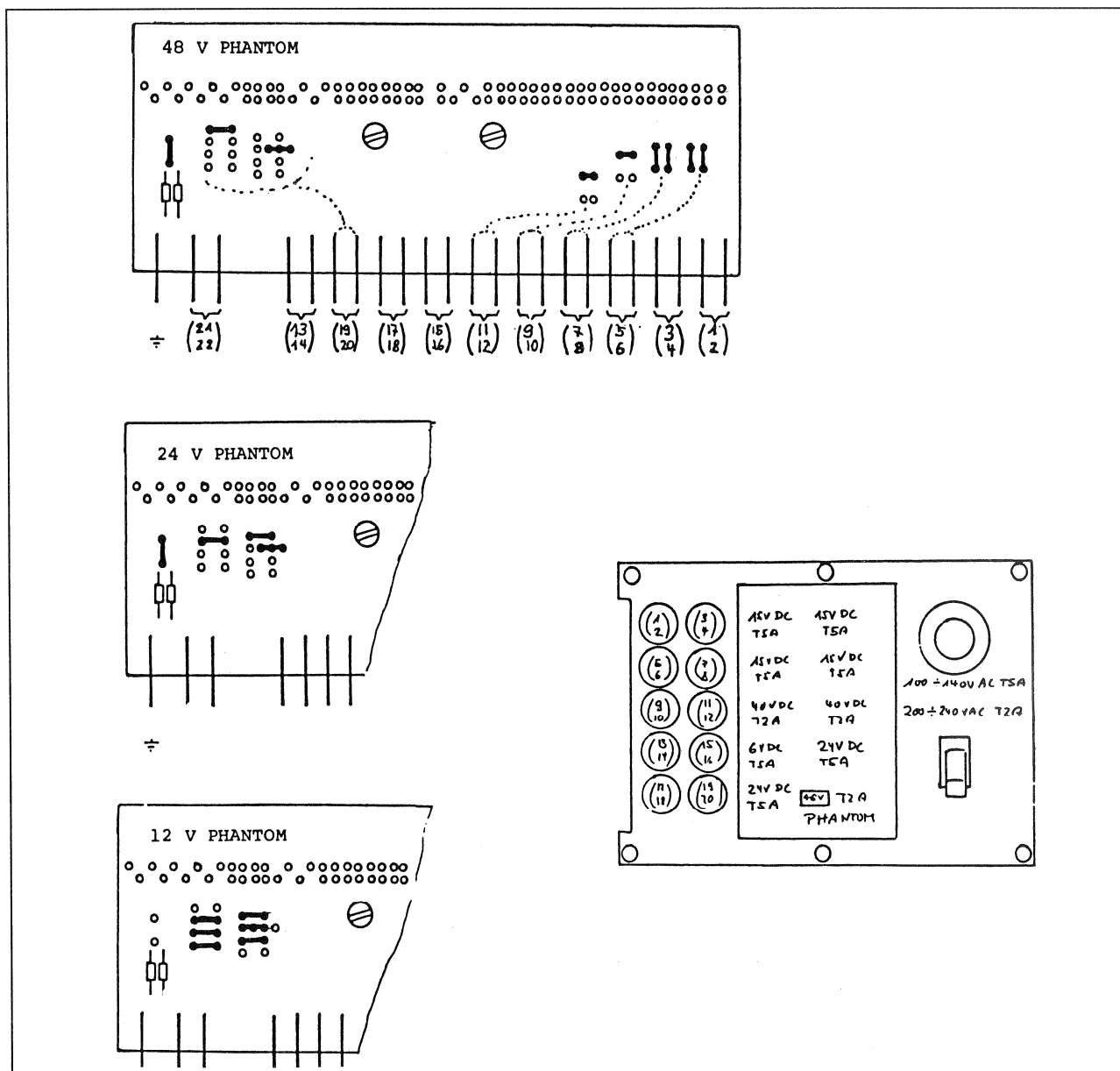
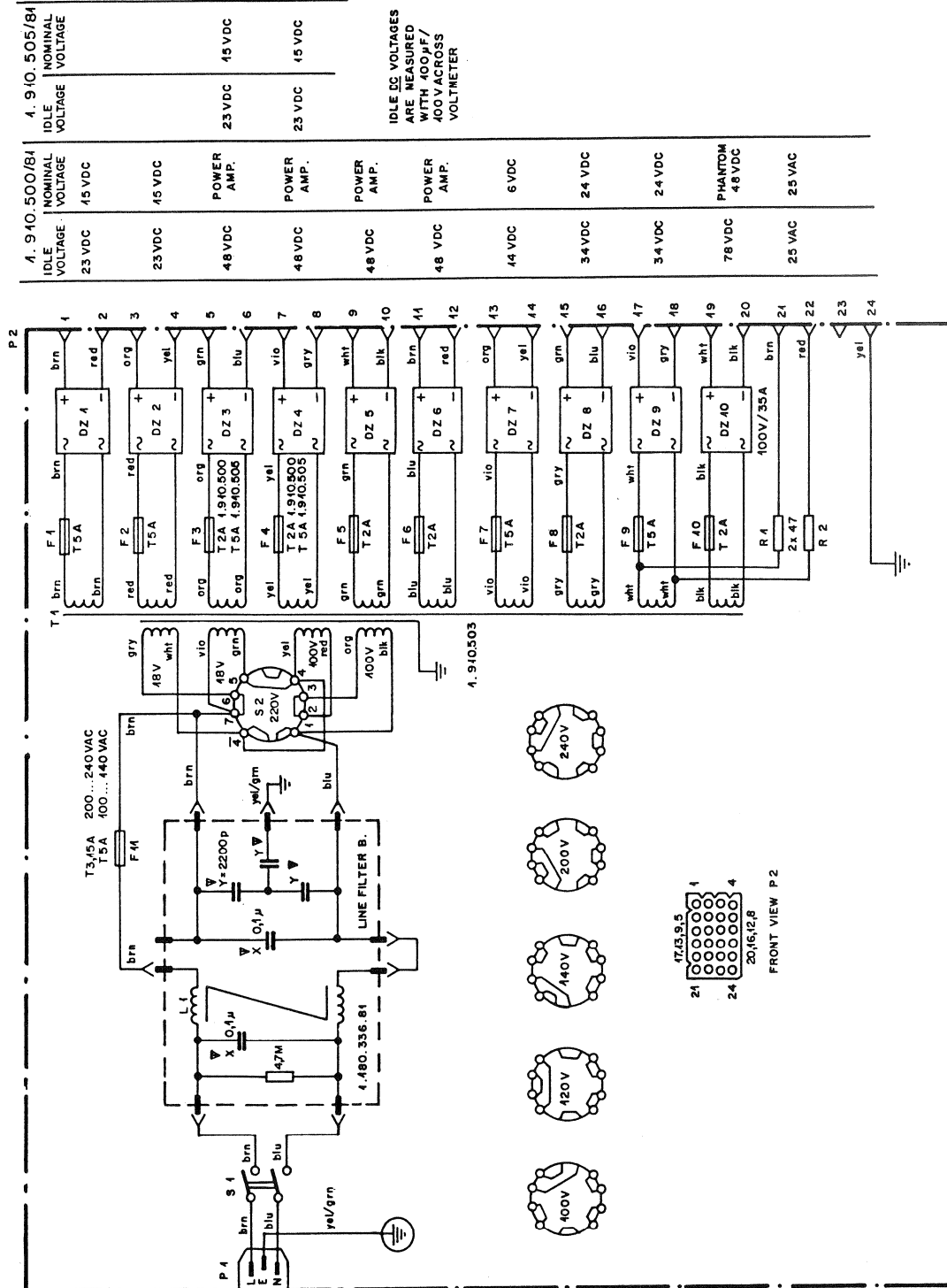

Fig. 7

Conversion of phantom powering

- Convert trafo-block
- Change resistor on the connection PCB of the input unit
 - 48V 6,8 kOhm/0,4 % 1.169.200.21
 - 24V 4,3 kOhm/0,4 % Draft IEC 268-15A
 - 12V 680 Ohm/0,4 % 1.169.200.20
- Reconnect the stranded wire on the stabilizer PCB 1.915.107

MAINS—TRANSFORMER—BLOCK 1.910.500.81 / 1.910.505.81



DATE:	28.4.82	19.8.83	2.3.84	3.6.85	
SIGN:	<i>fr</i>	<i>me</i>	<i>wh</i>	<i>ml</i>	
STUDER REGENSDORF ZÜRICH	MAINS - TRANSFORMER - BLOCK				SC 1.910.500/81 SC 1.910.505/81

Stabilisator 5 ... 24 V 1.915.106 /1.915.108

Spannungsstabilisator dessen Ausgangsspannung und Kurzschlussstrom mit Widerständen extern einstellbar ist. Mit Ausnahme der Phantom Stromversorgung werden alle in den Mischpulten der Serie 900 benötigten Betriebsspannungen mit den beiden Kartentypen 1.915.106 und 1.915.108 stabilisiert.

Leuchtdiode zur Anzeige des Betriebszustandes.

Drei von vorne zugängliche Messpunkte zur Kontrolle der Referenz- und Ausgangsspannung.

1. Schutzeinrichtungen

- "Crow Bar" schaltet ab bei zu hoher Ausgangsspannung
- Temperaturüberwachung am Regeltransistor
- Verpolungsschutz am Ausgang
- Langsames Hochfahren der Spannung beim Einschalten

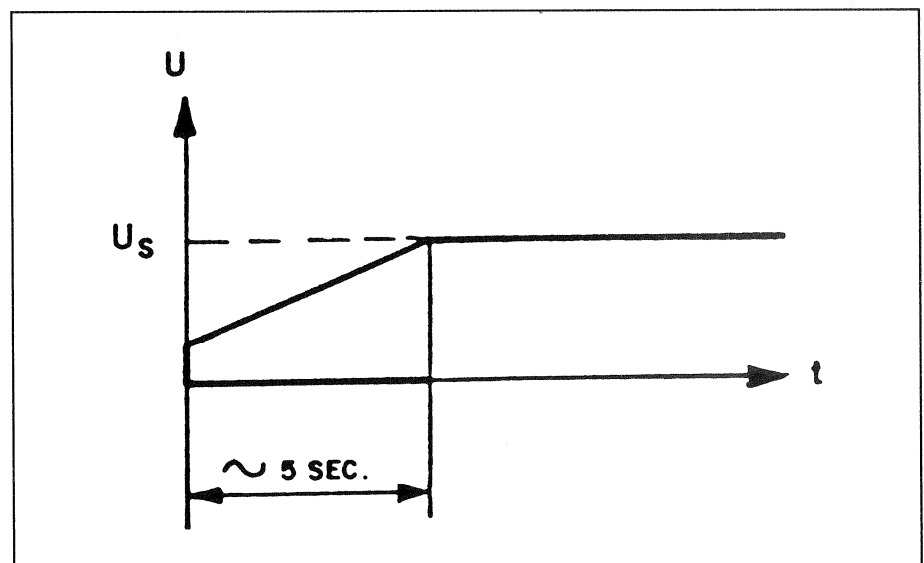

Fig. 7

Beim Betrieb als Doppelstabilisator für die Stromversorgung von Verstärkern mit positiver und negativer Speisespannung werden zwei Stabilisatorkarten gekoppelt.

Die Ausgangsspannung des einen Stabilisators steuert die Ausgangsspannung des anderen (Tracking). Damit werden die Koppelkondensatoren der angeschlossenen Audioverstärker nicht unnötig belastet.

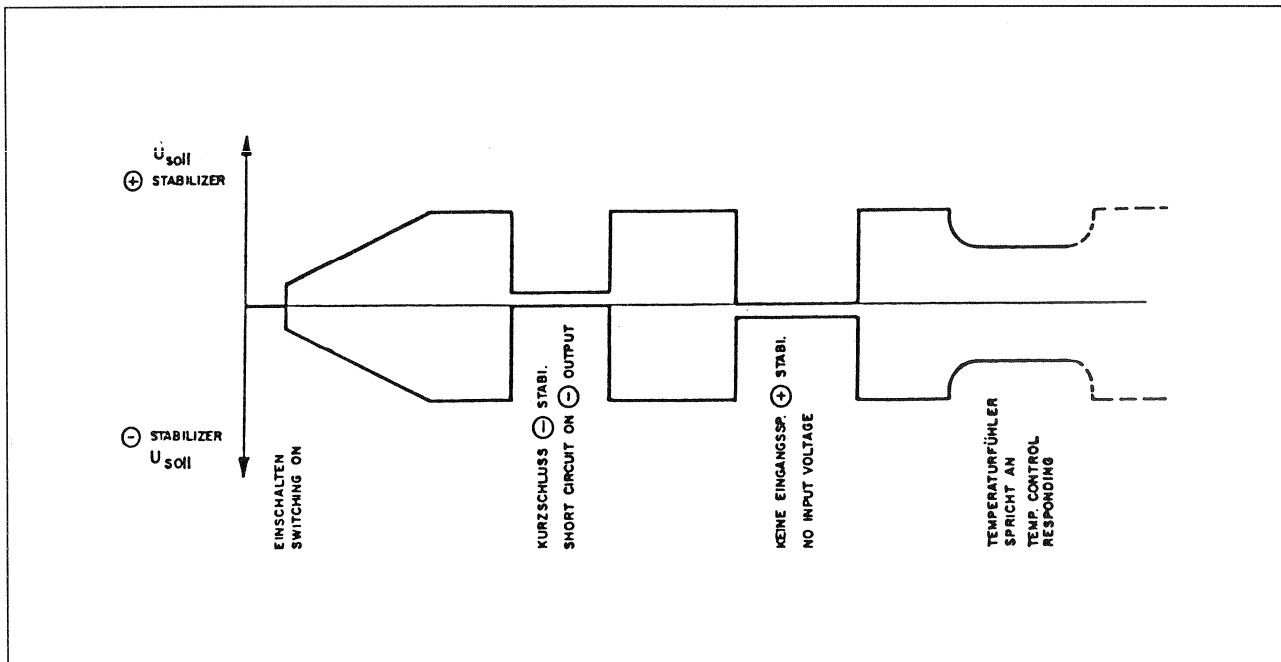

Fig. 8

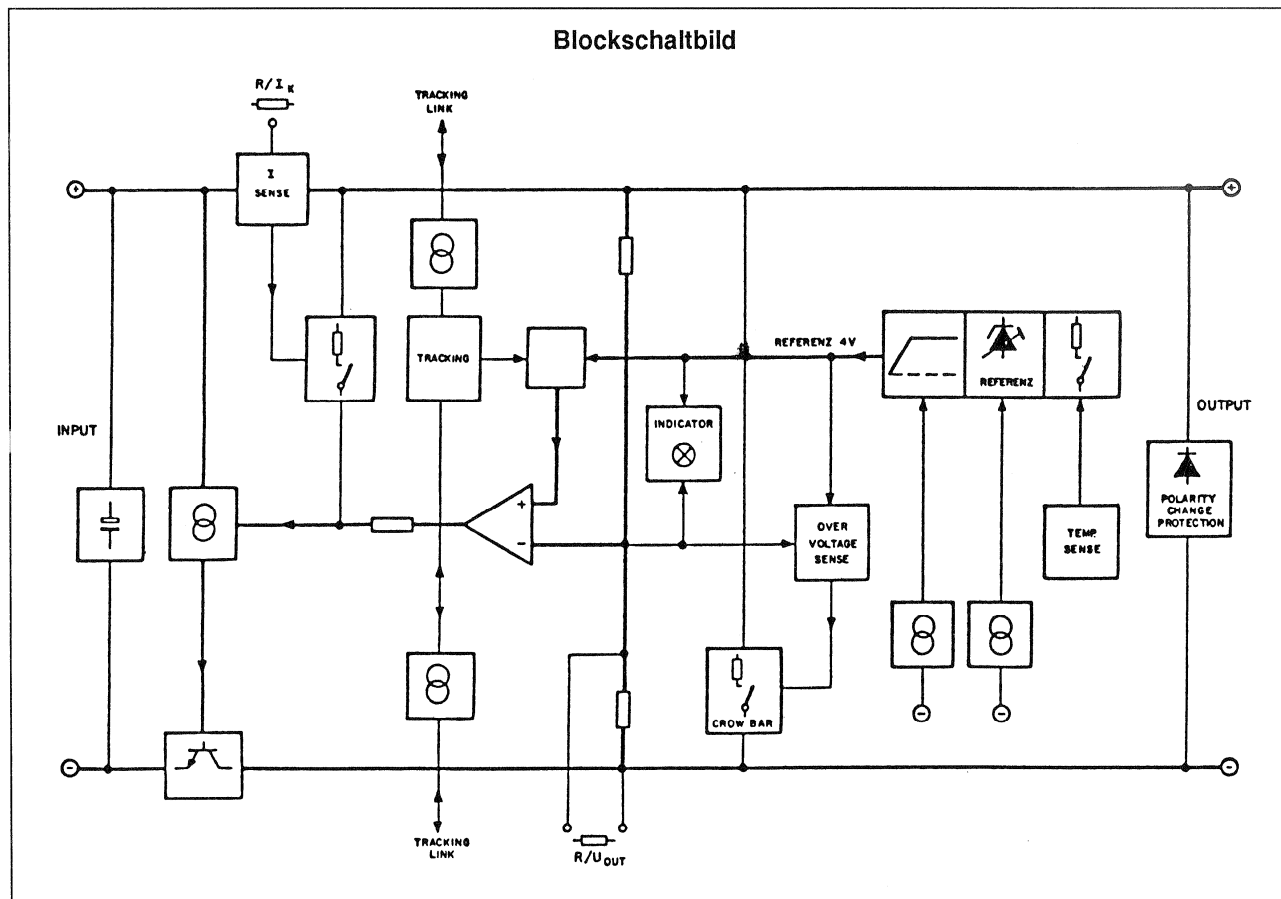

Fig. 9

2. Technische Daten

1.915.106

1.915.108

Ausgangsspannung extern programmierbar	$U = 5...24V$	$U = 5...24V$
Minimale Eingangsspannung (ohne Rippel)	$U_{min} = U + 1,5V$	$U_{min} = U + 1,5V$
Maximale Eingangsspannung	$U_{max} = 36V$	$U_{max} = 36V$
Kurzschlussstrom extern programmierbar	$I_k \approx 0,5...4,5A$	$I_k \approx 0,5...8,0A$
Max. Verlustleistung am Kühlblech	$P \approx 18 W$	$P \approx 30 W$

Kurzschlussverhalten

Bei Ueberlast regelt der Temperatursensor die Ausgangsspannung zurück.

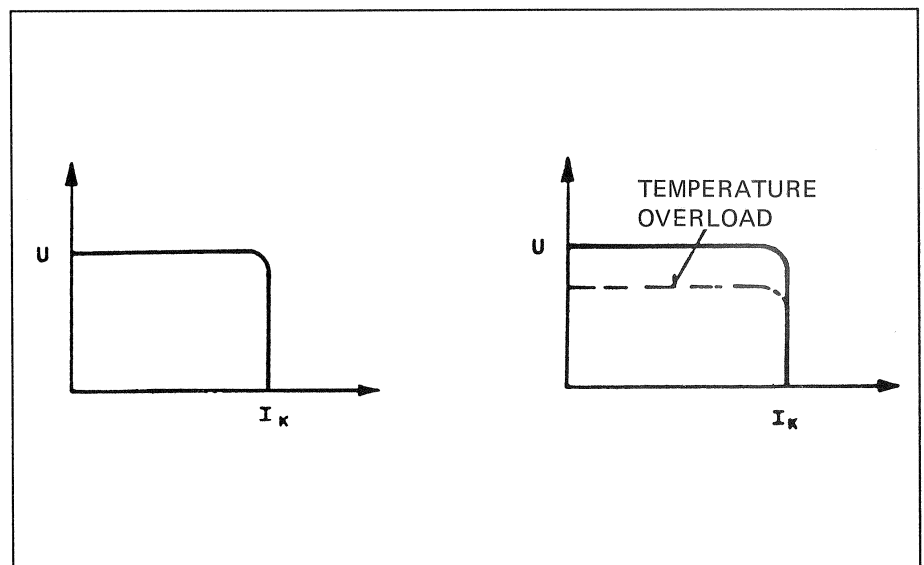

Fig. 10

Ueberspannungsschutz spricht an bei ca. 15% Ueberspannung am Ausgang

Max. Ausgangsstrom	@ $U_{15V} : 5A$ @ $U_{6V} : 8A$	@ $U_{15V} : 5A$ @ $U_{6V} : 8A$
Ueberlagerte Brummspannung	$U_{Br} \leq 100\mu V$	$U_{Br} \leq 100\mu V$
Leerlaufstrom	$I_o (@U_{in} 30V) = 30mA$	$I_o (@U_{in} 30V) = 30mA$

3. Mechanische Daten**1.915.106****1.915.108**

Abmessungen	Europakarte 100mm x 160mm	Europakarte 100mm x 160mm
Breite	33mm, 7 E	66mm, 14 E
Steckersystem	DIN 41 612 TYP B	DIN 41 612 TYP B
Gewicht	ca. 360 gr	ca. 560 gr

Stabilisator 5 ... 24 V 1.915.106 / 1.915.108

The output voltage and the short-circuit current of this voltage stabilizer are externally adjustable with resistors. Except for the phantom supply, all operating voltages of the Series 900 mixers are stabilized with the two types of circuit board numbered as 1.915.106 and 1.915.108.

Pilot LED for indicating the operating status.

Three test points for checking the reference voltage and the output voltage are accessible from the front.

1. Protective features

- "Crow Bar" disconnects if overvoltages are detected
- Temperature monitoring at regulating transistor
- Polarity confusion protection at output
- Slow voltage run-up when unit is switched on

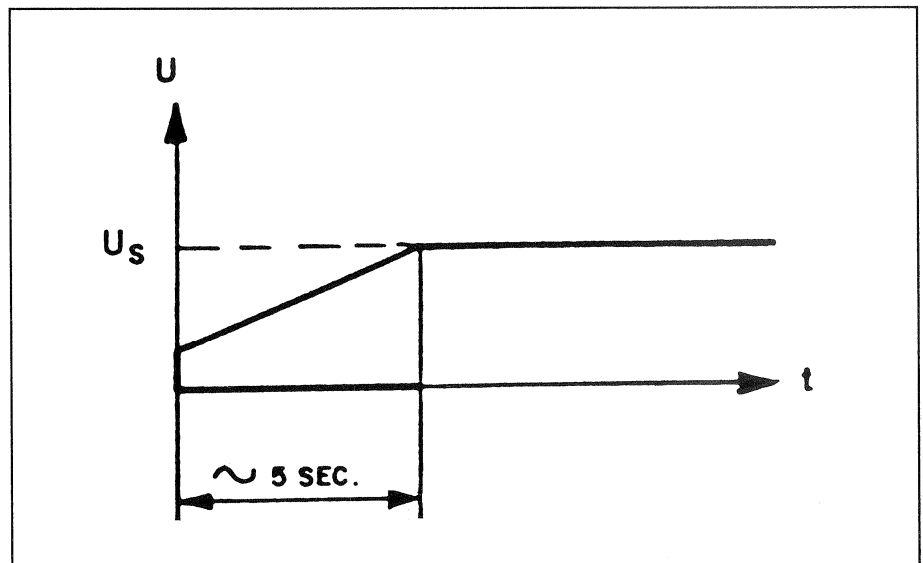

Fig. 8

Dual stabilizer operation for supplying amplifiers with negative and positive supply voltages is possible by coupling two stabilizer boards.

The output voltage of the first stabilizer controls the output voltage of the other (tracking). In this manner the coupling capacitors of the audio amplifiers are not unnecessarily loaded.

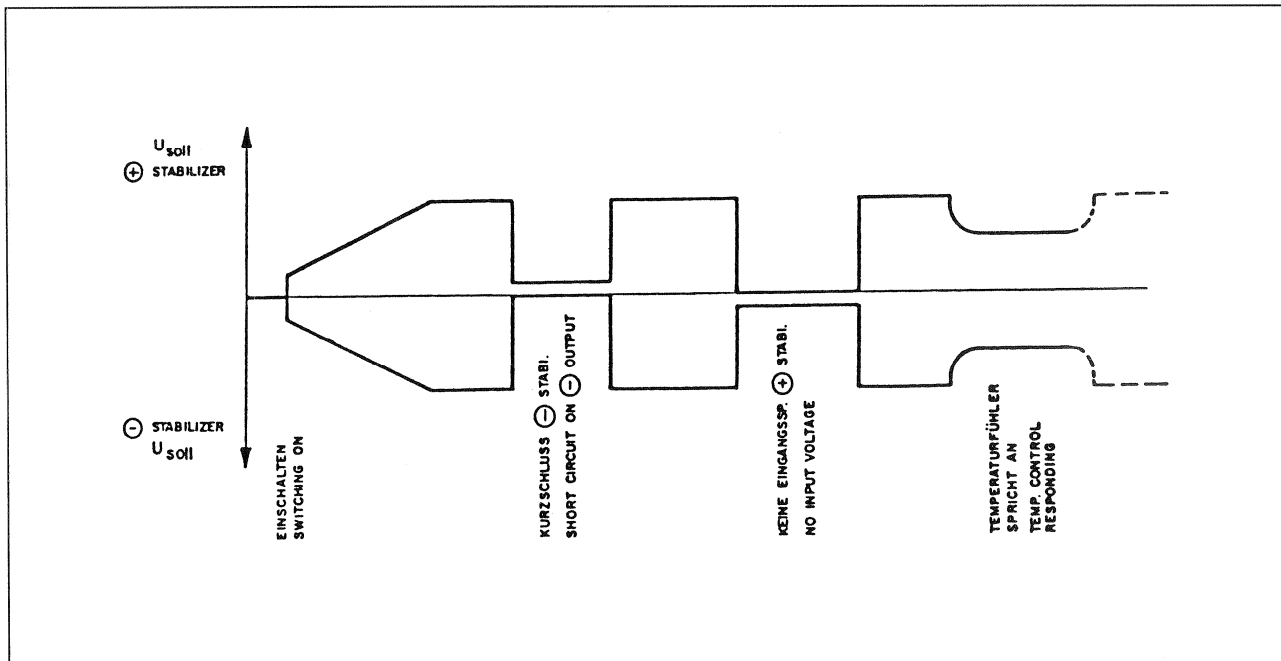

Fig. 9

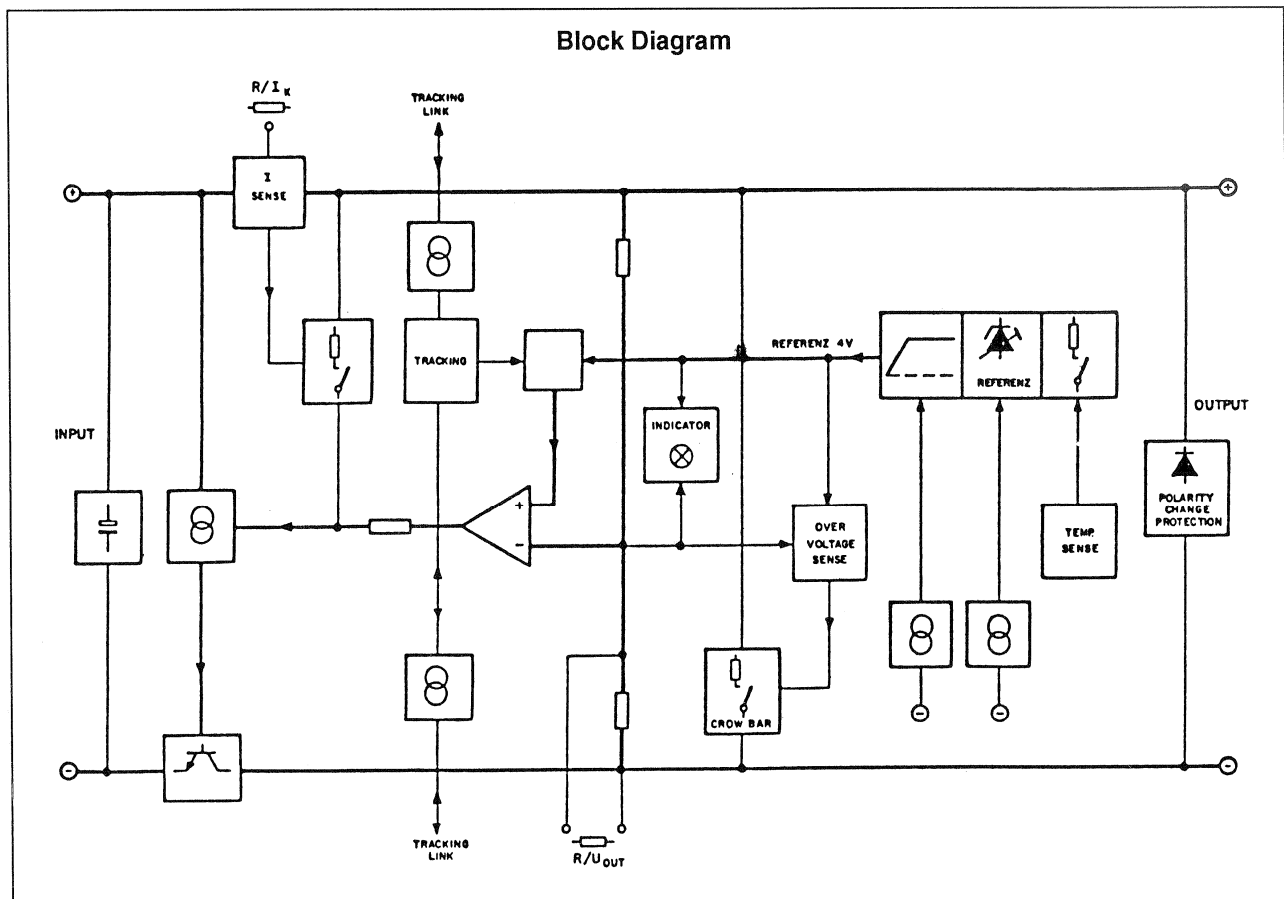

Fig. 10

2. Specifications

1.915.106

1.915.108

Output voltage externally programmable	$U = 5...24V$	$U = 5...24V$
Minimum input voltage without ripple	$U_{\min} = U + 1,5V$	$U_{\min} = U + 1,5V$
Maximum input voltage	$U_{\max} = 36V$	$U_{\max} = 36V$
Short-circuit current externally progr.	$I_k \approx 0,5...4,5A$	$I_k \approx 0,5...8,0A$
Max. power dissipation at heat sink	$P \approx 18W$	$P \approx 30W$

Short circuit response:

In the event of an overload the output voltage is regulated down by the temperature sensor.

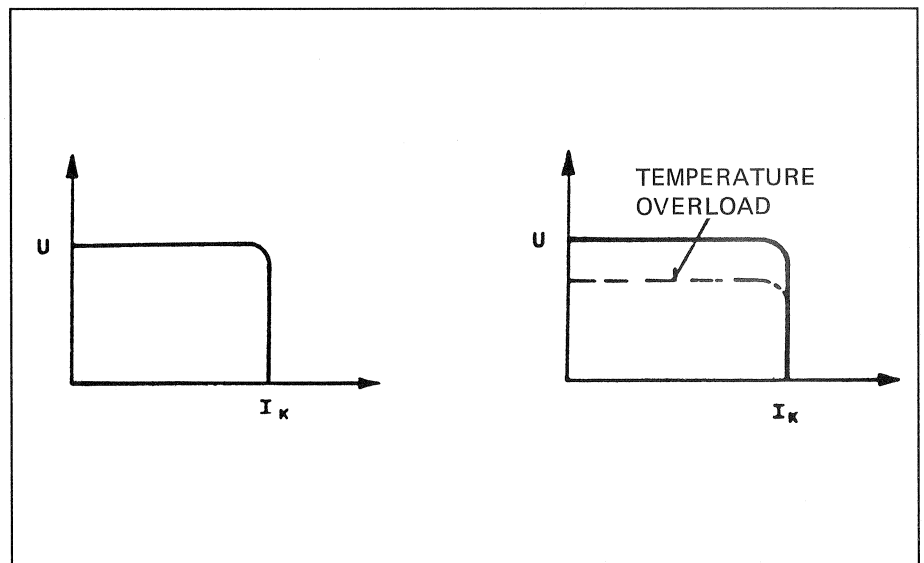

Fig. 11

Over-voltage sense responds at approx. 15% excess output voltage

Maximum output current	@ U_{15V} : 5A @ U_{6V} : 8A	@ U_{15V} : 5A @ U_{6V} : 8A
Superimposed ripple voltage	$U_{Br} 100 V$	$U_{Br} 100 V$
Idle current	$I_o(@U_{in} 30V) = 30mA$	$I_o(@U_{in} 30V) = 30mA$

3. Mechanical Data**1.915.106****1.915.108**

Dimensions	"Europe" PCB 100mm x 160 mm	"Europe" PCB 100mm x 160 mm
Width	33mm, 7 U	66mm, 14 U
Connector system	DIN 41 612 type B	DIN 41 612 type B
Weight	360 gr	560 gr

STABILIZER 5/24V 1.915.106 22.6.83 /1.915.108

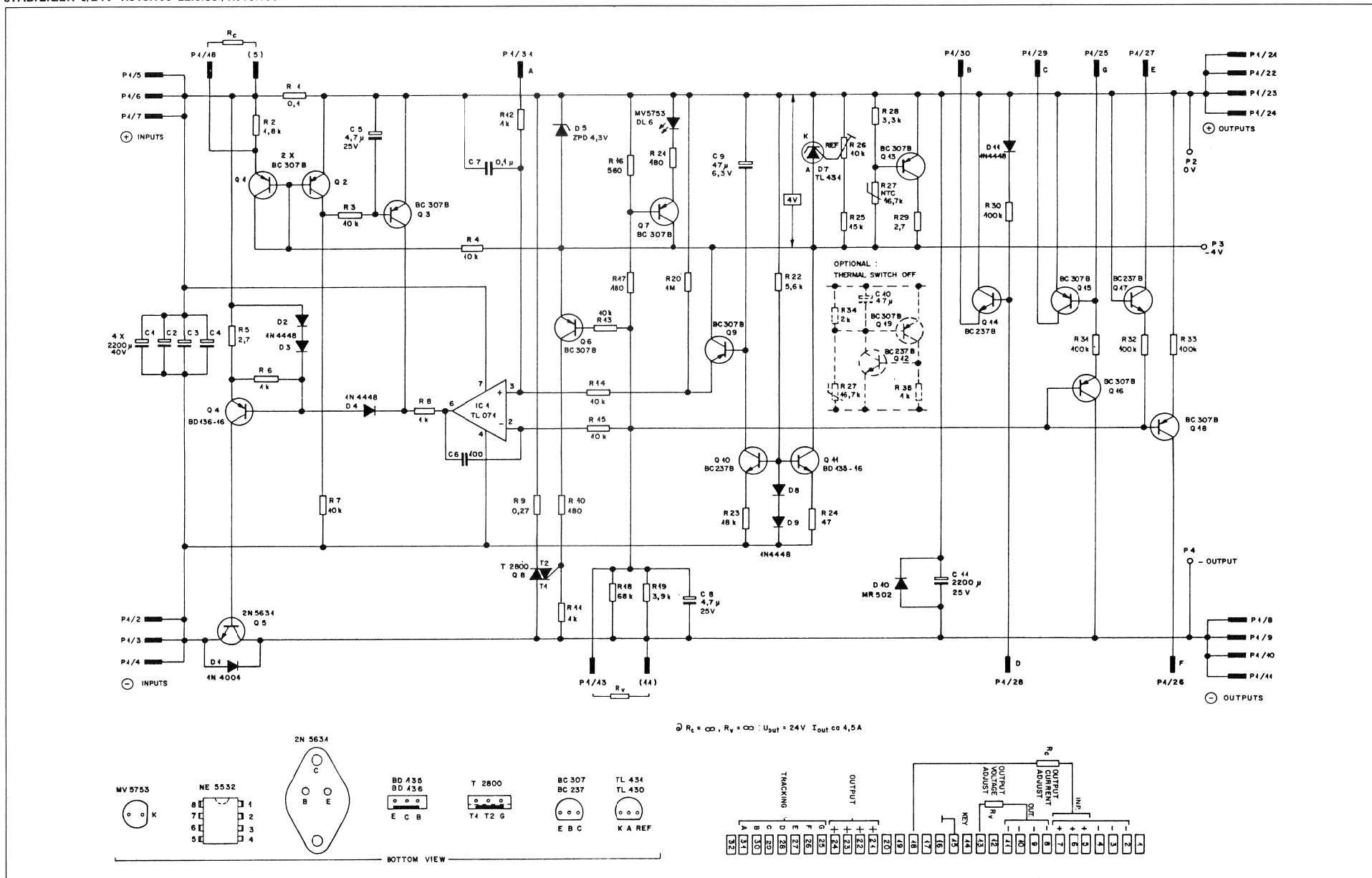

STABILIZER 5/24V 1.915.106

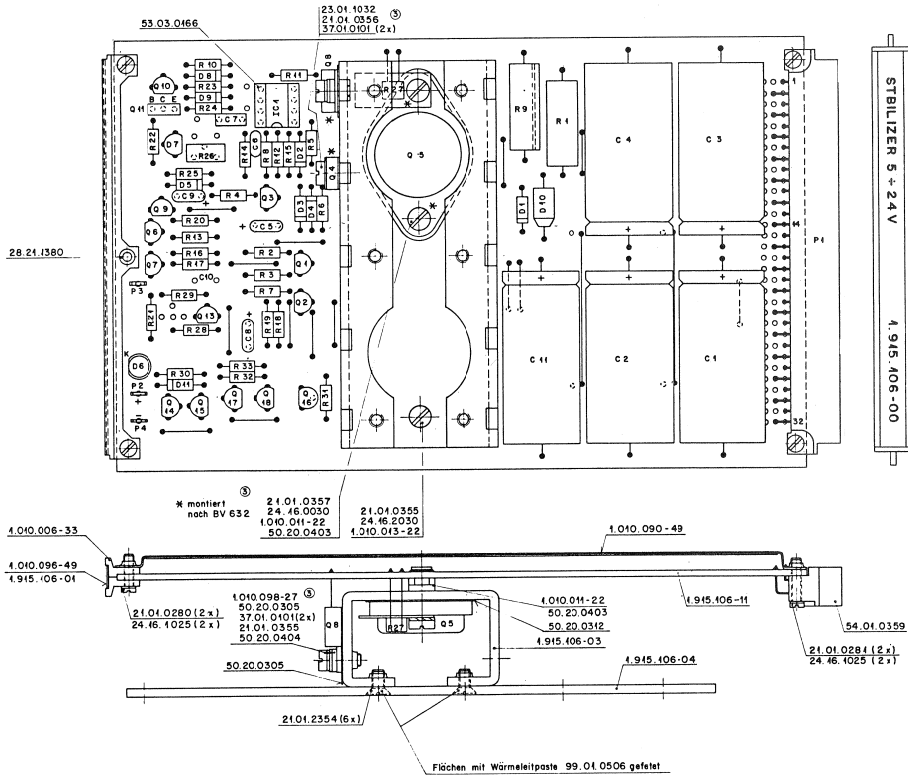

STABILIZER 5 - 24 V
1.915.106-00

IND. POS. NO.	PART NO.	VALUE	SPECIFICATIONS/EQUIVALENT	MFR.
C 1	53.25.2222	2200µF	4W	EL
C 2	53.25.2222	2200µF	4W	EL
C 3	53.25.2222	2200µF	4W	EL
C 4	53.25.2222	2200µF	4W	EL
C 5	53.26.5479	4,7µF	25 V	SEL
C 6	53.38.4101	100 pF		CER
C 7	53.04.0104	0,1µF		PE
C 8	53.26.5479	4,7µF	25V	SAL
C 9	53.26.0470	4,7µF	6,3V	SAL
C 10				
C 11	53.25.2222	2200µF	75V	EL
D 1	50.14.0145	1N4004	1A	
D 2	50.04.0125	1N4448		
D 3	50.14.0125	1N4448		
D 4	50.14.0125	1N4448		
D 5	50.04.1170	ZPD 431	5%	
D 6	50.04.2444	MX525	LED	CHA-28-B WOLCH
D 7	50.10.0106	7L 430	16 A 430 CLP	IC THF
D 8	50.04.0125	1N4448		
D 9	50.04.0125	1N4448		
D 10	50.04.0507	MR502	3A/30V	
D 11	50.04.0125	1N4448		
IC 1	50.03.0103	7L 071	LF351 SINGLE FET OPA	TII/II

IND.	DATE	NAME	EL - Electrolytic	MS - Monsanto
①			SAL - Solid Aluminium <td>CM - Chicago Miniatur</td>	CM - Chicago Miniatur
②			PE - Polyester	TI - Texas Instruments
③	22.6.83	th	CER - CERAMIC	N - National
④	22.7.81	th		F - Fairchild

STUDER Stabilizer 5 ÷ 24 V 1.915.106.00 page 1 of 3

IND. POS. NO.	PART NO.	VALUE	SPECIFICATIONS/EQUIVALENT	MFR.
Q 1	50.03.0515	BC 307 B	NPN (General purpose 50/100/40V)	ang
Q 2	50.03.0515	BC 307 B	NPN	
Q 3	50.03.0515	BC 307 B	NPN	
Q 4	50.03.0515	BD 435 B	NPN min 1A/44V	4851
Q 5	50.03.0542	2N563 A	NPN min 10A/min 60V 200W	N
Q 6	50.03.0515	BC 307 B	NPN	
Q 7	50.03.0515	BC 307 B	NPN	
Q 8	50.03.0106	T 2800	TRIAC 8 A S-H6 D	8/01
Q 9	50.03.0515	BC 307 B	NPN	
Q 10	50.03.0436	BC 237 B	NPN (General purpose 50/100/40V)	ang
Q 11	50.03.0495	BD 435-K	NPN P min 2W	4851
Q 12				
Q 13	50.03.0515	BC 307 B	NPN	
Q 14	50.03.0436	BC 237 B	NPN	
Q 15	50.03.0515	BC 307 B	NPN	
Q 16	50.03.0515	BC 307 B	NPN	
Q 17	50.03.0436	BC 237 B	NPN	
Q 18	50.03.0515	BC 307 B	NPN	
R 1	57.55.5108	0,1Ω	4W	
R 2	57.11.4182	1,8k	2%	
R 3	57.11.4103	10k		
R 4	57.11.4103	10k		
R 5	57.11.4279	9,7Ω		
R 6	57.11.4102	1k		
R 7	57.11.4103	10k		
R 8	57.11.4102	1k		
R 9	57.55.5277	0,27Ω	4W	

IND.	DATE	NAME	H - Matsushita	R - RCA
①			S - Siemens	T - Telefunken
②	22.6.83	th	GE - General Electric	
③	22.7.81	th		

STUDER Stabilizer 5 ÷ 24 V 1.915.106.00 page 2 of 3

IND. POS. NO.	PART NO.	VALUE	SPECIFICATIONS/EQUIVALENT	MFR.
R 10	57.11.4111	180Ω		
R 11	57.11.4102	1k		
R 12	57.11.4102	1k		
R 13	57.11.4103	10k		
R 14	57.11.4103	10k		
R 15	57.11.4103	10k		
R 16	57.11.4561	510Ω	2%	
R 17	57.11.4111	180Ω	2%	
R 18	57.11.4683	68k	2%	
R 19	57.11.4392	3,9k	2%	
R 20	57.11.4105	1M		
R 21	57.11.4111	180Ω		
R 22	57.11.4562	5,1k		
R 23	57.11.4103	10k		
R 24	57.11.4470	47Ω		
R 25	57.11.4153	15k		
R 26	58.01.7183	10k	LIN 114 CERMET	
R 27	57.98.0234	167k	2100°C NTC 2322 640 38005	PH
R 28	57.11.4392	3,9k		
R 29	57.11.4279	9,7Ω		
R 30	57.11.4103	10k		
R 31	57.11.4103	10k		
R 32	57.11.4103	10k		
R 33	57.11.4103	10k		

IND.	DATE	NAME	PH - Philips
①			
②			
③			
④	22.6.83	th	
⑤	22.7.81	th	

STUDER Stabilizer 5 ÷ 24 V 1.915.106.00 page 3 of 3

STABILIZER 5/24V/5A 1.915.108 22.6.83

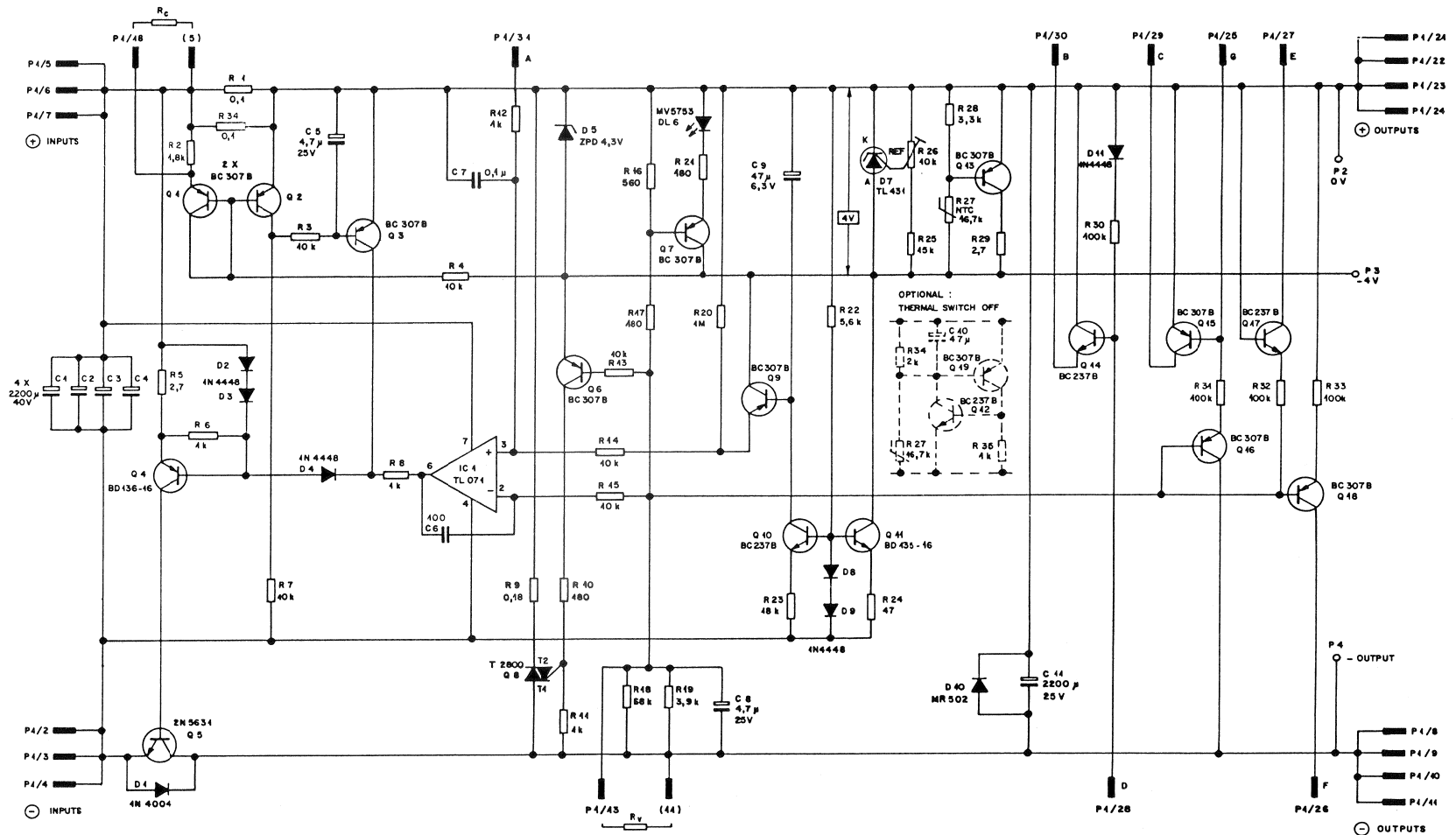

@ $R_v = \infty : U_{ref} = 24V$

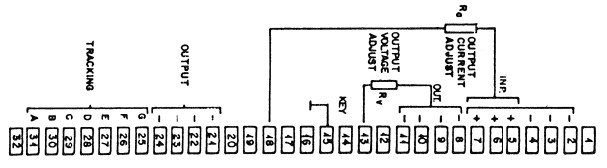
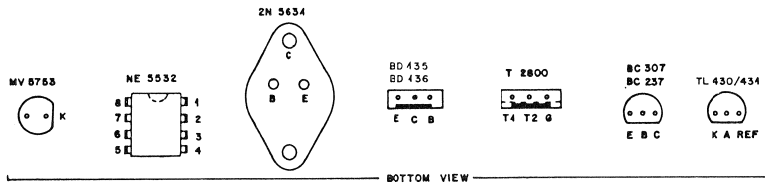

STABILIZER 5/24V/5A 1.915.108

STABILIZER 5 + 24V 1.915.108-00

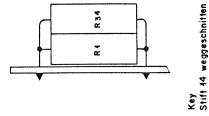

Key
Stift H4 weggeschliffen

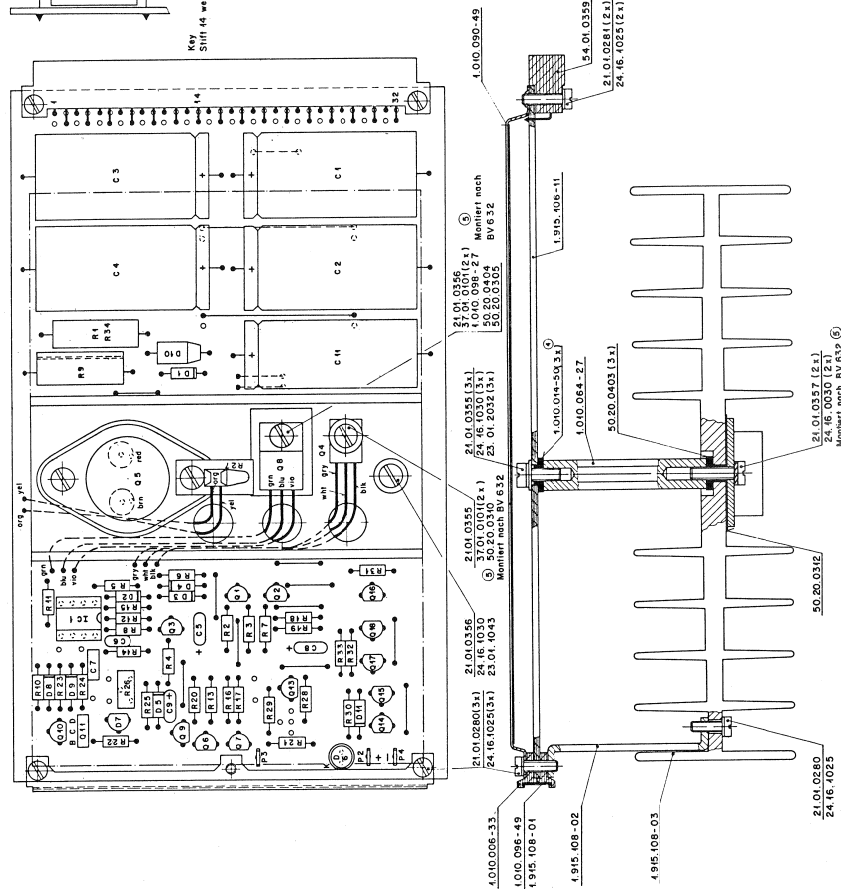

INDX POS NO	PART NO	VALUE	SPECIFICATIONS/EQUIVALENT	MFR
C 1	59.75.5222	2200 µF	40V	EL
C 2	59.25.5222	2200 µF	40V	EL
C 3	59.25.5222	2200 µF	40V	EL
C 4	59.25.5222	2200 µF	40V	EL
C 5	59.75.5479	4,7 µF	25 V	SAL
C 6	59.34.4101	100 pF		CER
C 7	59.04.0104	0,1 µF		PE
C 8	59.76.5479	4,7 µF	25V	SAL
C 9	59.76.0470	4,7 µF	6,3V	SAL
C 10				
C 11	59.25.4222	2200 µF	25V	EL
D 1	50.04.0105	1N4004	1A	
D 2	50.04.0125	1N4448		
D 3	50.04.0125	1N4448		
D 4	50.04.0125	1N4448		
D 5	50.04.1170	ZPD 43H	5%Z	
D 6	50.04.2411	MY5753	LED	CH-284 B WSKM
D 7	50.10.0106	7L 430	1/2 A 430 CLP	IC TIF
D 8	50.04.0125	1N4448		
D 9	50.04.0125	1N4448		
D 10	50.04.0507	HR502	3A/30V	
D 11	50.04.0125	1N4448		
JG 1	50.03.0103	7L 071	LF351 SINGLE FET OPA	TJIN

INDX	DATE	NAME			
①			EL - Electrolytic	MS - Monsanto	
②			SAL - Solid Aluminium	CM - Chicago Miniatur	
③			PE - Polyester	TI - Texas Instruments	
④	22.6.83	JH	CER - CERAMIC	N - National	
⑤	22.11.82	JH		F - Fairchild	

STUDER Stabilizer 5 + 24V/5A 1.915.108.00 page 1 of 3

INDX POS NO	PART NO	VALUE	SPECIFICATIONS/EQUIVALENT	MFR
R 10	57.11.1111	180 Ω		
R 11	57.11.1102	1 k		
R 12	57.11.1102	1 k		
R 13	57.11.1103	10 k		
R 14	57.11.1102	10 k		
R 15	57.11.1103	10 k		
R 16	57.11.1103	10 k	2%	
R 17	57.11.1111	180 Ω	2%	
R 18	57.11.1103	68 k	2%	
R 19	57.11.1102	3,3 k	2%	
R 20	57.11.1105	1 M		
R 21	57.11.1111	180 Ω		
R 22	57.11.1102	5,6 k		
R 23	57.11.1103	18 k		
R 24	57.11.1103	47 Ω		
R 25	57.11.1103	15 k	LIN 1/4 CERMET	
R 26	58.71.7103	10 k		
R 27	57.99.0204	16,7 k	±100°C ATC 2322 640 38005	PH
R 28	57.11.1102	3,3 k		
R 29	57.11.1102	2,2 Ω		
R 30	57.11.1104	100 k		
R 31	57.11.1104	100 k		
R 32	57.11.1104	100 k		
R 33	57.11.1104	100 k		
R 34	57.56.5108	0,1 Ω	4W	

INDX	DATE	NAME			
①			PH - Philips		
②					
③					
④	22.6.83	JH			
⑤	22.11.82	JH			

STUDER Stabilizer 5 + 24V/5A 1.915.108.00 page 3 of 3

INDX POS NO	PART NO	VALUE	SPECIFICATIONS/EQUIVALENT	MFR
Q 1	50.03.0515	BC307B	PNP General purpose 0,4A/100V 140V	WST
Q 2	50.03.0515	BC307B	PNP	
Q 3	50.03.0515	BC307B	PNP	
Q 4	50.03.0510	BD135C	PNP min 1A/140V	WST
Q 5	50.03.0342	2N5631	NPN min 10A/min 40V 200W	M
Q 6	50.03.0515	BC307B	PNP	
Q 7	50.03.0515	BC307B	PNP	
Q 8	50.03.0101	T 2800	TRIAC 8A 8-116 D	R/G
Q 9	50.13.0515	BC307B	PNP	
Q 10	50.03.0436	BC237B	NPN General purpose 0,4A/100V 140V	
Q 11	50.03.0495	BD135C	NPN P min 2W	WST
Q 12				
Q 13	50.03.0515	BC307B	PNP	
Q 14	50.03.0436	BC237B	NPN	
Q 15	50.03.0515	BC307B	PNP	
Q 16	50.03.0515	BC307B	PNP	
Q 17	50.03.0436	BC237B	NPN	
Q 18	50.03.0515	BC307B	PNP	
Q 19				
Q 20				
Q 21				
Q 22				
Q 23				
Q 24				
Q 25				
Q 26				
Q 27				
Q 28				
Q 29				
Q 30				
Q 31				
Q 32				
Q 33				
Q 34				

INDX	DATE	NAME			
①			M - Motorola		
②			R - RCA		
③			S - Siemens		
④	22.6.83	JH	T - Telefunken		
⑤	22.11.82	JH	GE - General Electric		

STUDER Stabilizer 5 + 24V/5A 1.915.108.00 page 2 of 3

Phantom / 24 V Stabilisator 1.915.107

Stabilisatorkarte mit zwei getrennten, isoliert aufgebauten Spannungsstabilisatoren für die Phantom- und 24 V Stromversorgung. Zwei Leuchtdioden zeigen den Betriebszustand an. Zwei Messpunktpaare sind mit Messklemmen von vorne zugänglich.

1. Phantomversorgung

Die Ausgangsspannung von 12V, 24V oder 48V ist mit einer Brücke einstellbar (Beachten Sie, dass eine Änderung der Phantomspannung auch eine Anpassung der Eingangsspannung und eine Änderung der Phantomeinspeisewiderstände im Mikrokanal bedingt).

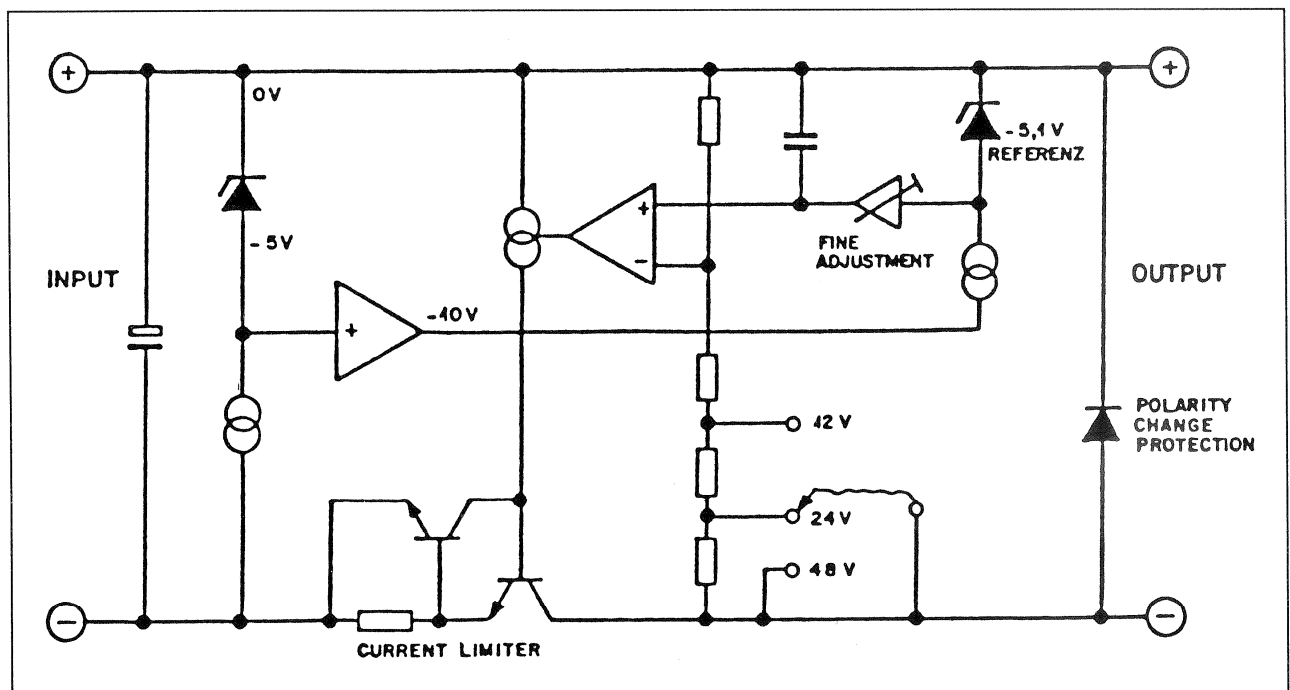

Fig. 11

2. Technische Daten

**Ausgangsspannung
einstellbar** $U = 12V, 24V, 48V$

Minimale Eingangsspannung für 12V $U_{min} = 13V$

Max. Eingangsspannung $U_{max} = 100V$

Kurzschlussstrom $I_k = 350mA$

Laststrom $I_{max} = 300mA$

Kurzschlussverhalten mit automatisch, spannungsabhängigem "Fold Back"

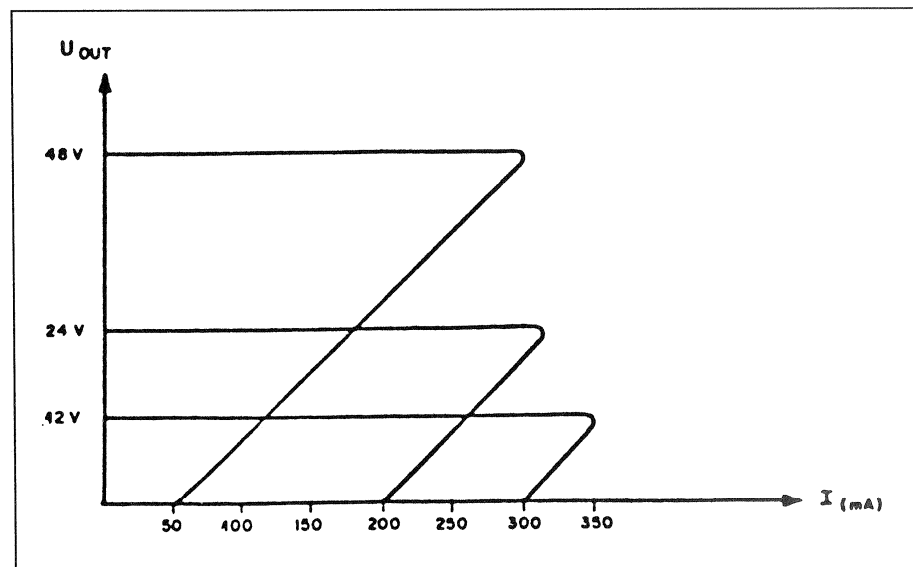

Fig. 12

Überlagerte Brummspannung $U_{Br} \leq 100\mu V$

Leerlaufstrom $I_{O@80V} U_{in} = 25mA$

3. 24V Stabilisator

Die Ausgangsspannung ist fest eingestellt auf 24V DC.

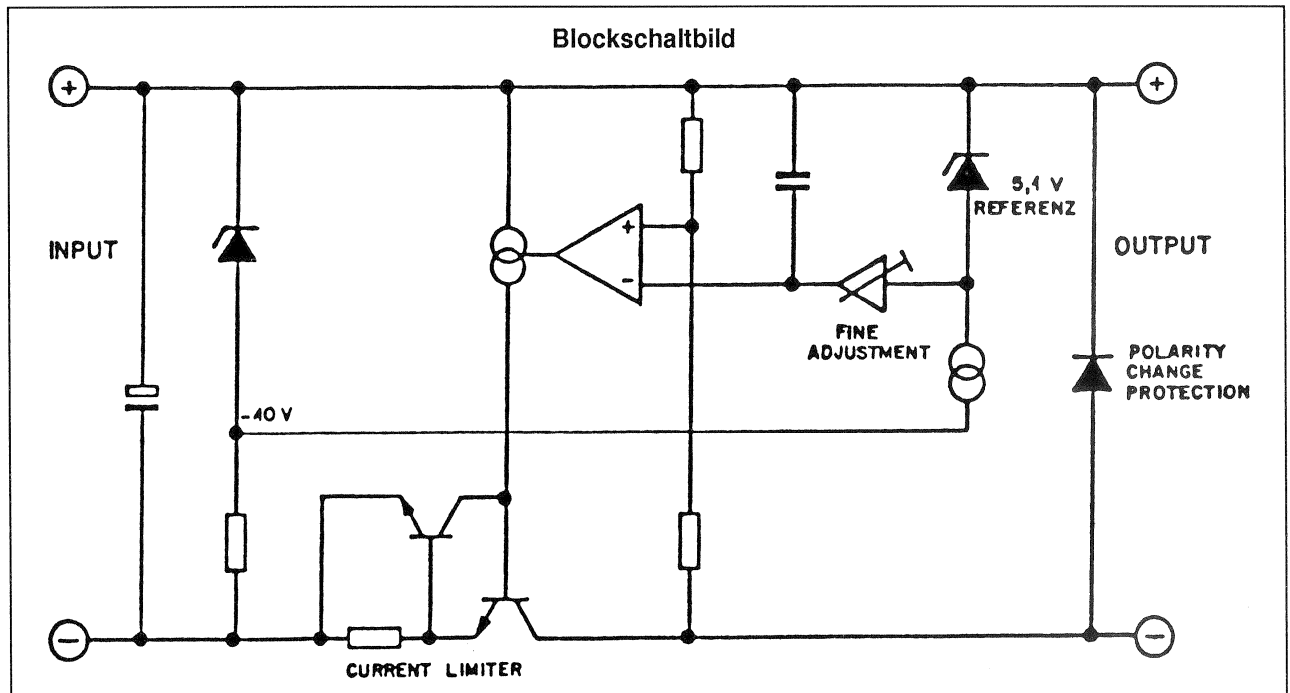

Fig. 13

4. Technische Daten

Ausgangsspannung	$U = 24V$
Minimale Eingangsspannung (ohne Ripple)	$U_{\min} = 25V$
Maximale Eingangsspannung	$U_{\max} = 36V$
Kurzschlussstrom	$I_k \sim 660mA$
Laststrom	$I_{\max} = 600mA$
	Kurzschlussverhalten mit automatischem "Fold Back"

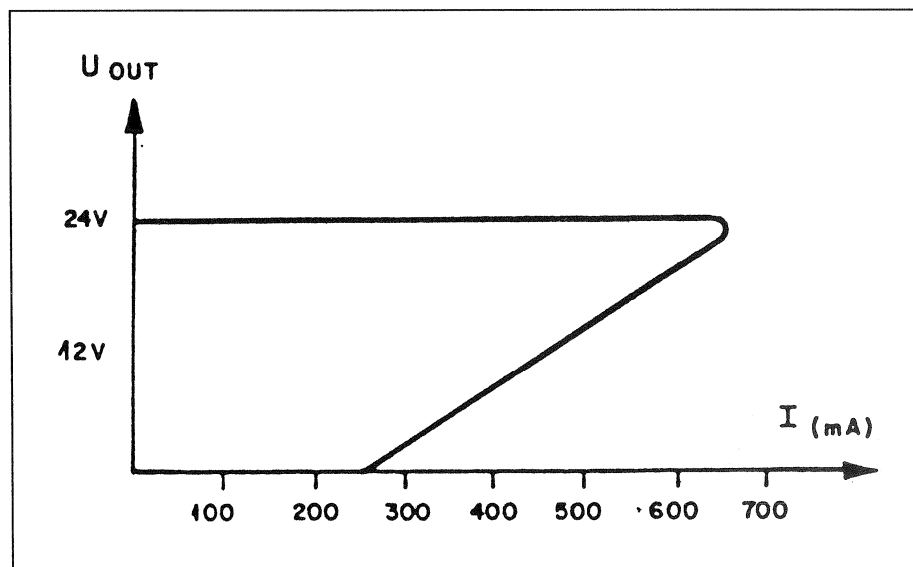

Fig. 14

Ueberlagerte
Brummspannung $U_{Br} \leq 100 \mu V$

Leerlaufstrom $I_{O@Uin30V} = 20mA$

5. Mechanische Daten

Abmessungen "EUROPE" PCB 100mm x 160mm

Steckersystem DIN 416 12 Typ B

Breite 33mm 7m

Gewicht ca. 320 gr

Phantom / 24 V Stabilizer 1.915.107

Stabilizer board with two separate and isolated voltage stabilizers for the phantom supply and the 24V supply. The two pilot LEDs indicate the operating status. Two pairs of test points are accessible from the front with rest clips.

1. Phantom Supply

The 12V, 24V or 48V output voltage can be adjusted with a bridge. (Please note that any change of the phantom voltage requires a corresponding adjustment of the input voltage and the replacement of the phantom supply resistors is the microphone channel).

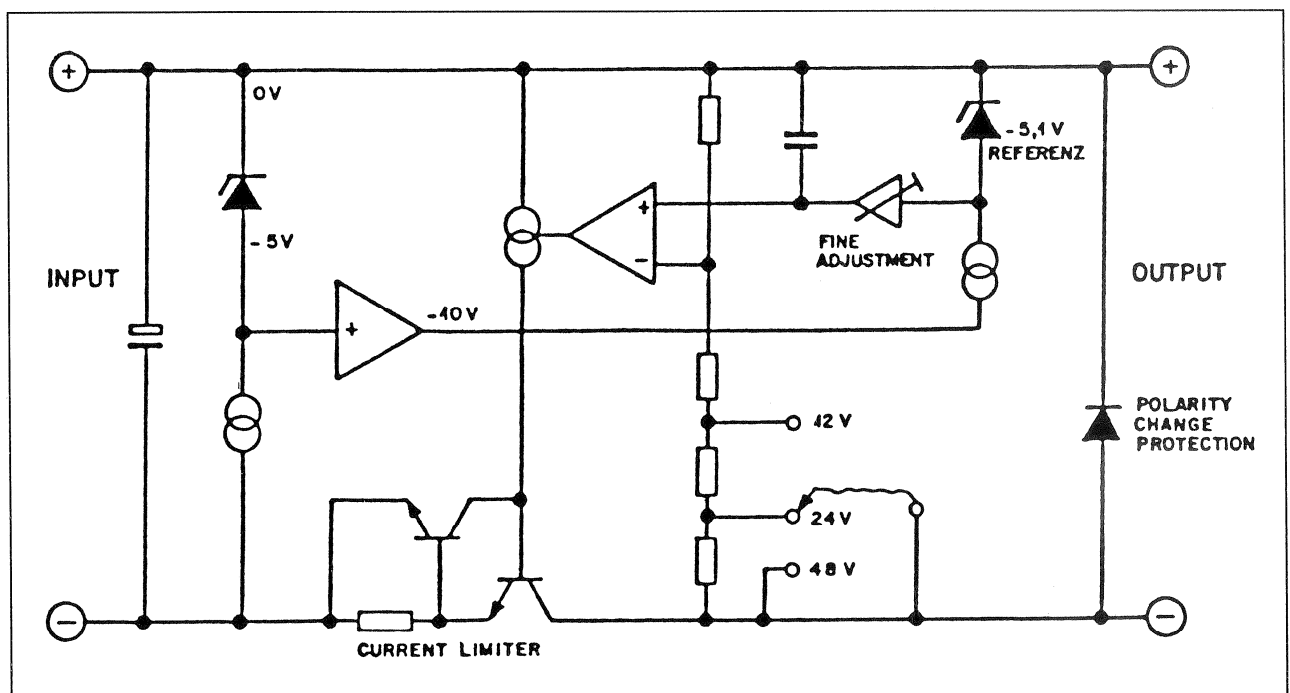

Fig. 12

2. Specifications

Output voltage, variable $U = 12V, 24V, 48V$

Minimum input voltage for 12V $U_{min} = 13V$

Max. input voltage $U_{max} = 100V$

Short-circuit current $I_k = 350mA$

Load current $I_{max} = 300mA$

Short-circuit response with automatic, voltage-dependent fold-back

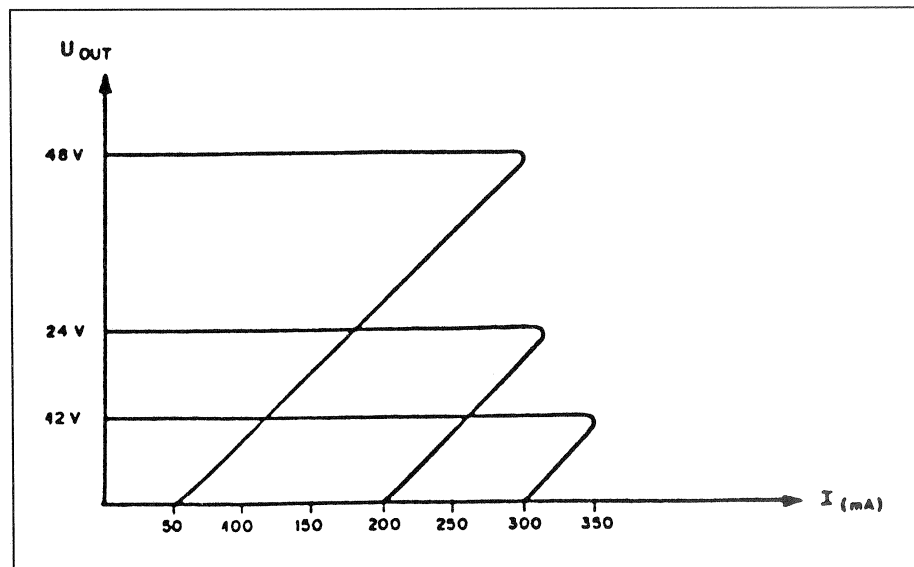

Fig. 13

Superimposed ripple voltage $U_{Br} \leq 100\mu V$

No-load current $I_{O@80V} U_{in} = 25mA$

3. 24V Stabilizer

The output voltage is permanently set to 24 VDC.

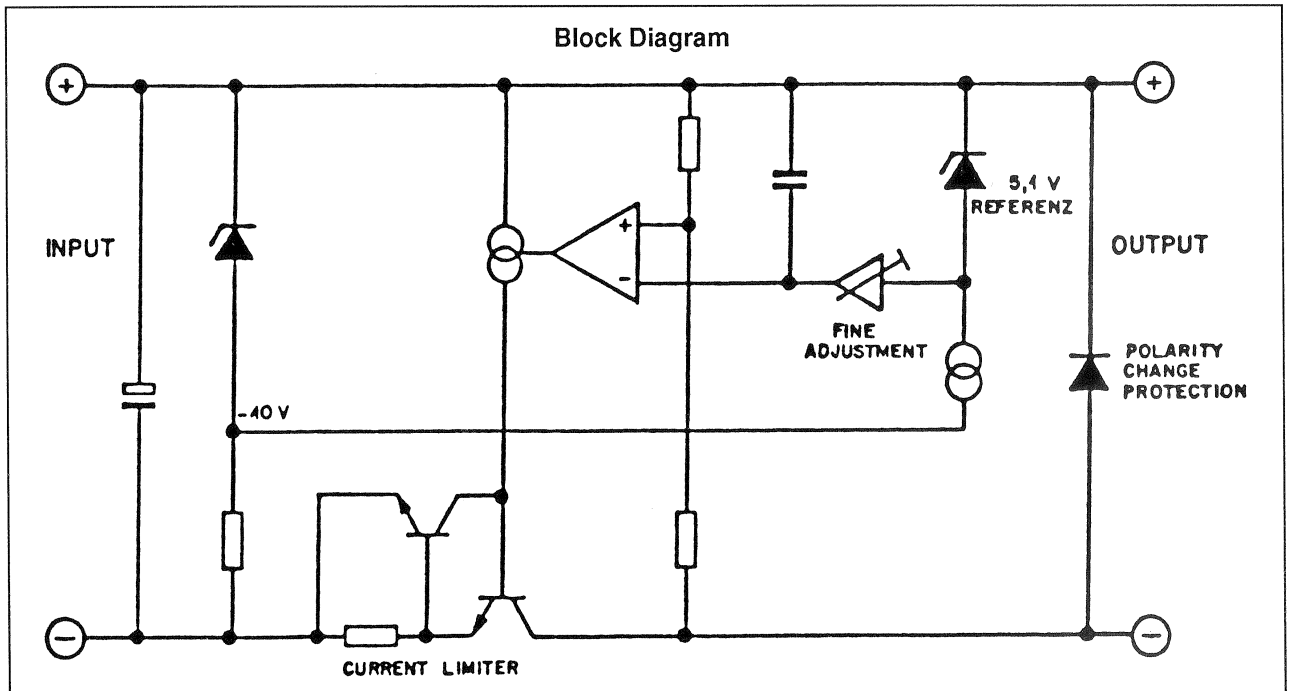

Fig. 14

4. Specifications

Output voltage	$U = 24V$
Minimum input voltage (without ripple)	$U_{\min} = 25V$
Maximum input voltage	$U_{\max} = 36V$
Short-circuit current	$I_k \sim 660mA$
Load current	$I_{\max} = 600mA$

Short-circuit response with automatic fold-back

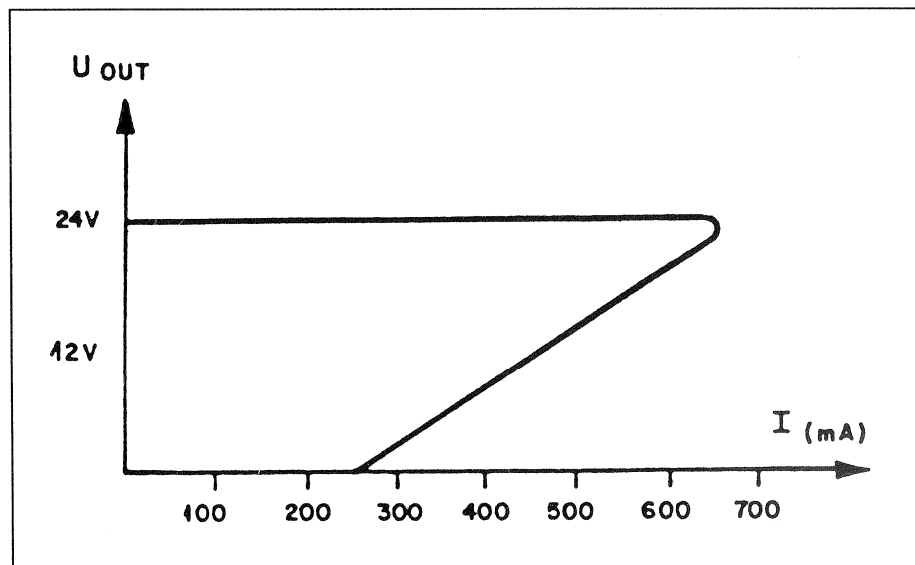

Fig. 15

Superimposed ripple voltage $U_{Br} \leq 100 \mu V$

No-load current $I_{O@U_{in}30V} = 20 \text{ mA}$

5. Mechanical Data

Dimensions	"EUROPE" PCB 100mm x 160mm
Connector system	DIN 416 12 type B
Width	33mm 7m
Weight	ca. 320 gr

PHANTOM 24V STABILIZER 1.915.107

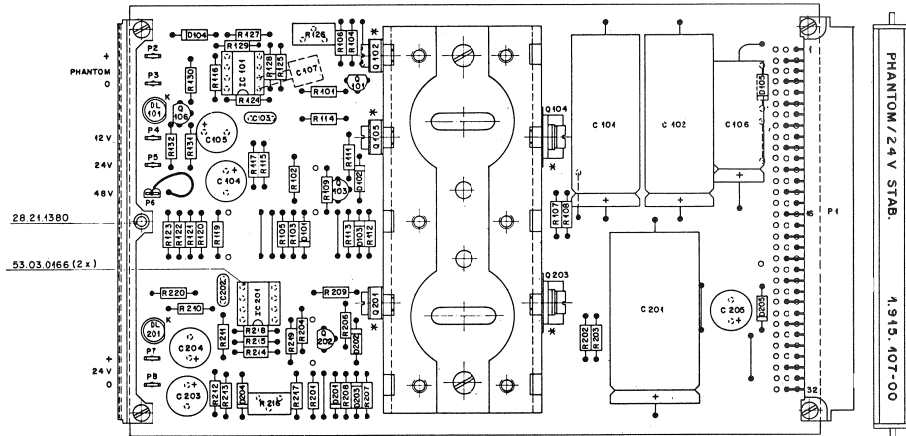

IND POS NO	PART NO	VALUE	SPECIFICATIONS/EQUIVALENT	MFR
C 101	59.25.7224	220µF	100V EL	
C 102	59.25.7224	220µF	100V EL	
C 103	59.34.4224	220µF	CER	
C 104	59.22.8220	22µF	63V EL	
C 105	59.22.5104	100µF	25V EL	
C 106	59.25.6471	470µF	63V EL	
C 201	59.25.5222	2200µF	40V EL	
C 202	59.34.4224	220µF	CER	
C 203	59.22.5104	100µF	25V EL	
C 204	59.22.5104	100µF	25V EL	
C 205	59.22.5104	100µF	25V EL	
C 107	59.34.2220	22pF	CER	
D 101	50.04.1412	Z 51V	51V @ 5mA 5%	
D 102	50.04.0425	1N4448		
D 103	50.04.0425	1N4448		
D 104	50.04.1412	Z 51V	51V @ 5mA 5%	
D 105	50.04.0105	1N4004	14V @ 4A	
D 201	50.04.1414	Z 10V	10V @ 5mA 5%	
D 202	50.04.0425	1N4448		
D 203	50.04.0125	1N4448		
D 204	50.04.1412	Z 51V	51V @ 5mA 5%	
D 205	50.04.0105	1N4004	41V @ 4A	
DL 101	50.04.2114	MV5753	CM4-2848 Ms/Gn	
DL 201	50.04.2114	MV5753	CM4-2848 Ms/Gn	

IND POS NO	PART NO	VALUE	SPECIFICATIONS/EQUIVALENT	MFR
IC 101	50.09.0404	TL 072	DUAL OPA	LF 353 N, TI
IC 201	50.09.0404	TL 072	DUAL OPA	LF 353 N, TI
Q 101	50.03.0442	BC 556	PNP 01A U _{ces} 80V	S, I
Q 102	50.03.0451	BD 139	NPN	P, S
Q 103	50.03.0340	BC 337	NPN 08A	P, TI
Q 104	50.03.0344	2N 6474	NPN	R
Q 105	50.03.0452	BD 140	PNP	P, S
Q 106	50.03.0496	BC 560	PNP 01A	S
Q 201	50.03.0452	BD 140	PNP	P, S
Q 202	50.03.0340	BC 337	NPN 08A	P, TI
Q 203	50.03.0344	2N 6474	NPN	R
R 101	57.11.4332	33k		
R 102	57.11.4332	33k		
R 103	57.11.4332	33k		
R 104	57.11.4103	10k		
R 105	57.11.4682	68k		
R 106	57.11.4103	10k		
R 107	57.11.4339	3.3		
R 108	57.11.4338	3.3		
R 109	57.11.4181	180		
R 110				
R 111	57.11.4223	22k		
R 112	57.11.4450	45		
R 113	57.11.4334	330		
R 114	57.11.4681	680		
R 115	57.11.4332	33k	2%	

IND	DATE	NAME	EL ELECTROLYTIC MS MONSANTO
⊙			CER CERAMIC CM CHICAGO MINIATUR
⊙	13.1.83	1/2	
⊙	9.6.81	1/2	

STUDER PHANTOM / 24V STAB. 1.915.107.00 page 1 of 4

IND	DATE	NAME	S SIEMENS I ITT
⊙			RA RAYTHEON N NATIONAL
⊙	13.1.83	1/2	TI TEXAS INSTR.
⊙	9.6.81	1/2	P PHILIPS R RCA

STUDER PHANTOM / 24V STAB. 1.915.107.00 page 2 of 4

IND POS NO	PART NO	VALUE	SPECIFICATIONS/EQUIVALENT	MFR
R 116	57.11.4332	33k		
R 117	57.11.4332	33k		
R 118				
R 119	57.11.4332	33k	2%	
R 120	57.11.4224	220k	2%	
R 121	57.11.4682	68k	2%	
R 122	57.11.4223	22k	2%	
R 123	57.11.4333	33k	2%	
R 124	57.11.4103	10k		
R 125	57.11.4332	33k		
R 126	58.01.7103	10k	LIN. 10%	
R 127	57.11.4333	33k		
R 128	57.11.4181	180		
R 129	57.11.4332	33k		
R 130	57.11.4682	68k		
R 131	57.11.4332	33k		
R 132	57.11.4181	180		
R 201	57.11.4332	33k		
R 202	57.11.4189	48		
R 203	57.11.4189	48		
R 204	57.11.4181	180		
R 205				
R 206	57.11.4103	10k		
R 207	57.11.4150	45		
R 208	57.11.4331	330		
R 209	57.11.4681	680		
R 210	57.11.4332	33k		
R 211	57.11.4103	10k		
R 212	57.11.4103	10k	2%	
R 213	57.11.4332	33k	2%	

IND POS NO	PART NO	VALUE	SPECIFICATIONS/EQUIVALENT	MFR
R 214	57.11.4103	10k		
R 215	57.11.4332	33k		
R 216	58.01.7103	10k	LIN. 10%	
R 217	57.11.4333	33k		
R 218	57.11.4181	180		
R 219	57.11.4332	33k		
R 220	57.11.4332	33k		

Modification List

1 13483			HF Problems
C 106	22µF =	470pF	
C 107	22µF =	new	

IND	DATE	NAME
⊙		
⊙		
⊙	13.1.83	1/2
⊙	9.6.81	1/2

STUDER PHANTOM / 24V STAB. 1.915.107.00 page 3 of 4

IND	DATE	NAME
⊙		
⊙		
⊙	13.1.83	1/2
⊙	9.6.81	1/2

STUDER PHANTOM / 24V STAB. 1.915.107.00 page 4 of 4

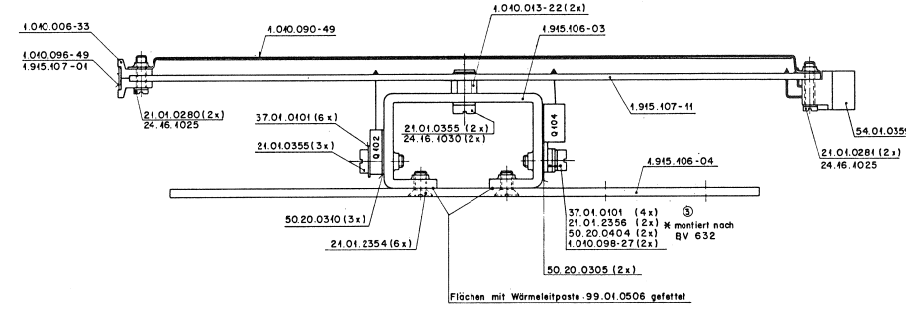

Relaiskarte Monitor Switch 5/1

1.915.601

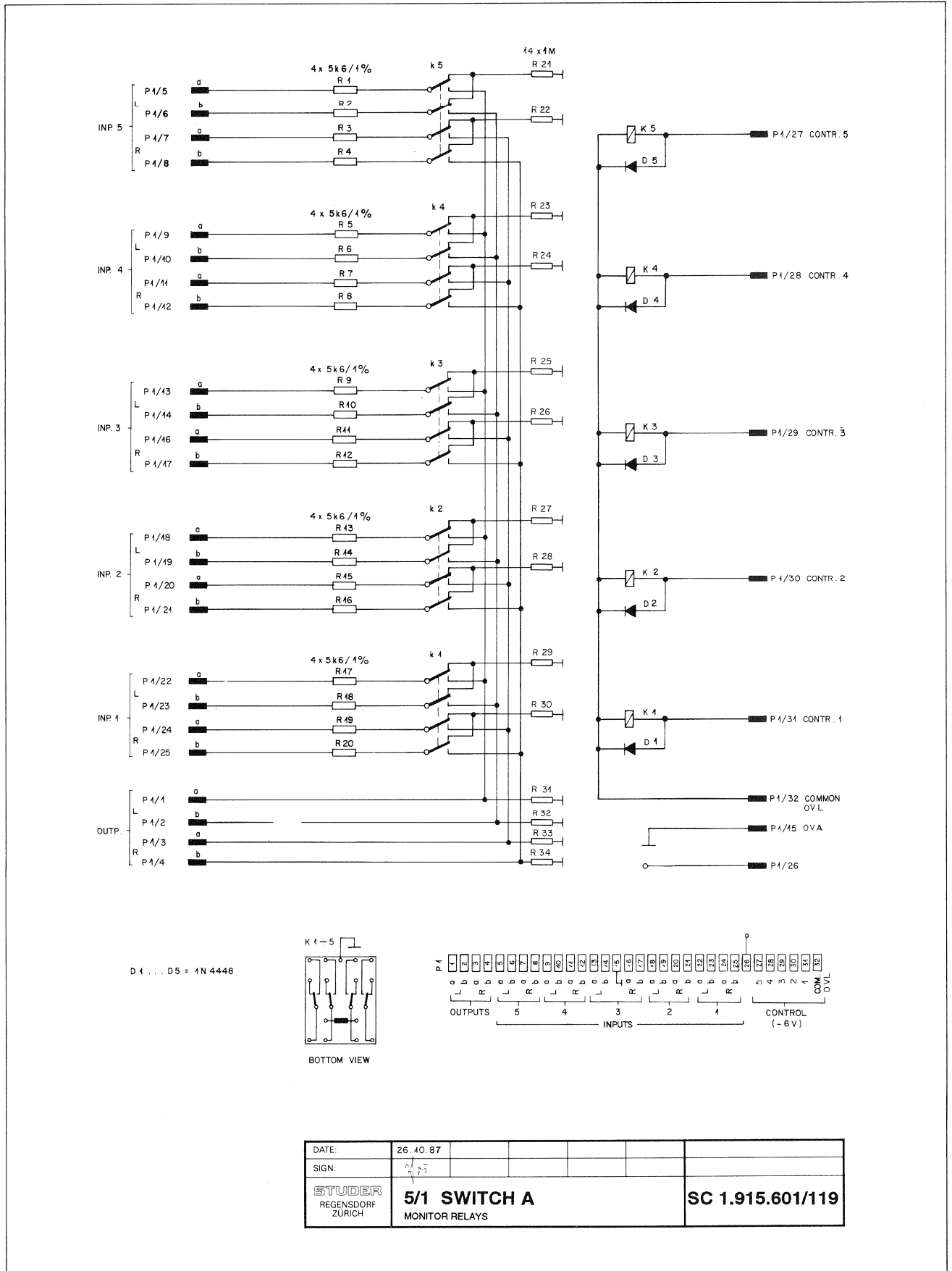

Relaiskarte Monitor Switch 5/1 1.915.601.81

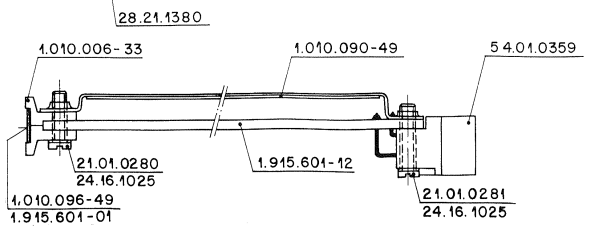
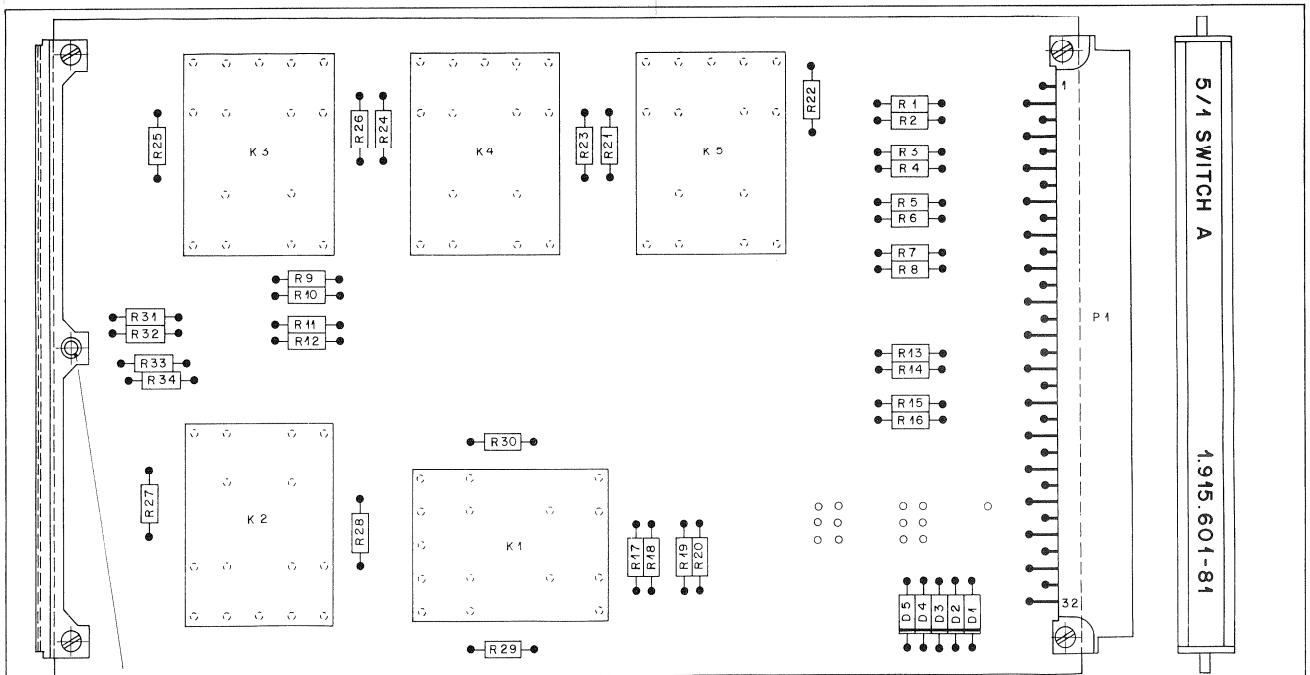

Norm-Nr.:	Güte:	Änderung:	③
DIN-Bez.:	Beh.:		②
Abmessung:			①
Zugehörige Unterlagen:	Freimasstoleranz:	Maßstab:	④
PL	±	2 : 1	
Ersatz für: 1.915.601-00	Ersetzt durch:	Kopie für:	
STUDER REGENSDORF ZÜRICH		Benennung: 5/1 SWITCH A	Nummer: 1.915.601-81

Ad	POS.	REF.No.	DESCRIPTION	MANUFACTURER
D.....1	50.04.0125	1N4448	SILICIUM	
D.....2	50.04.0125	1N4448	SILICIUM	
D.....3	50.04.0125	1N4448	SILICIUM	
D.....4	50.04.0125	1N4448	SILICIUM	
D.....5	50.04.0125	1N4448	SILICIUM	
K.....1	56.04.0146	4U/6V		NATIONAL/OMRON
K.....2	56.04.0146	4U/6V		NATIONAL/OMRON
K.....3	56.04.0146	4U/6V		NATIONAL/OMRON
K.....4	56.04.0146	4U/6V		NATIONAL/OMRON
K.....5	56.04.0146	4U/6V		NATIONAL/OMRON
R.....1	57.11.3562	5.6kΩ 1%		
R.....2	57.11.3562	5.6kΩ 1%		
R.....3	57.11.3562	5.6kΩ 1%		
R.....4	57.11.3562	5.6kΩ 1%		
R.....5	57.11.3562	5.6kΩ 1%		
R.....6	57.11.3562	5.6kΩ 1%		
R.....7	57.11.3562	5.6kΩ 1%		
R.....8	57.11.3562	5.6kΩ 1%		
R.....9	57.11.3562	5.6kΩ 1%		
R.....10	57.11.3562	5.6kΩ 1%		
R.....11	57.11.3562	5.6kΩ 1%		
R.....12	57.11.3562	5.6kΩ 1%		
R.....13	57.11.3562	5.6kΩ 1%		
R.....14	57.11.3562	5.6kΩ 1%		
R.....15	57.11.3562	5.6kΩ 1%		
R.....16	57.11.3562	5.6kΩ 1%		
R.....17	57.11.3562	5.6kΩ 1%		
R.....18	57.11.3562	5.6kΩ 1%		
R.....19	57.11.3562	5.6kΩ 1%		
R.....20	57.11.3562	5.6kΩ 1%		
R.....21		1MΩ		
R.....22		1MΩ		
R.....23		1MΩ		
R.....24		1MΩ		
R.....25		1MΩ		
R.....26		1MΩ		
R.....27		1MΩ		
R.....28		1MΩ		
R.....29		1MΩ		
R.....30		1MΩ		
R.....31		1MΩ		
R.....32		1MΩ		
R.....33		1MΩ		
R.....34		1MΩ		

Relaiskarte Monitor Switch 4/2

1.915.602

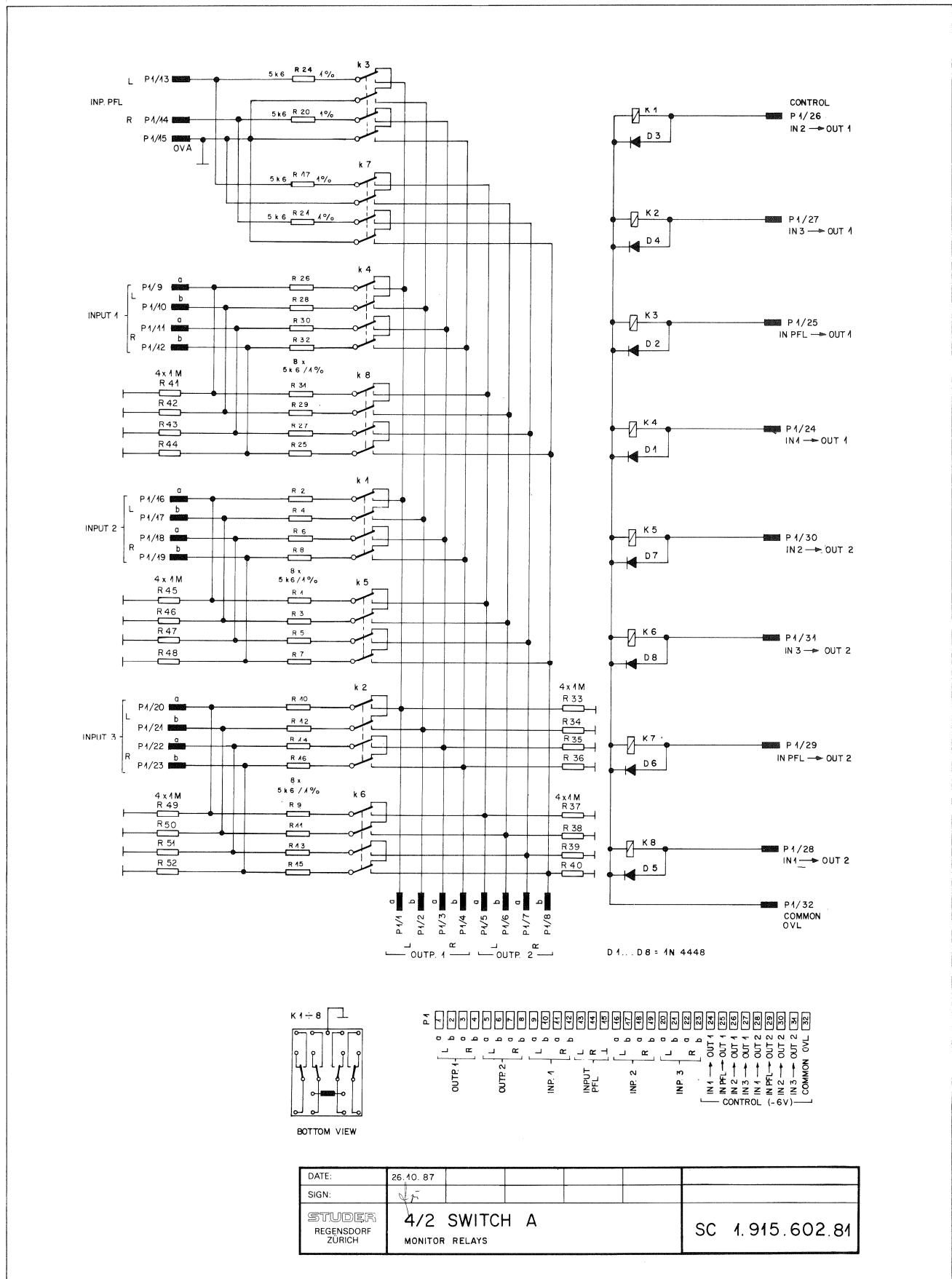

Relaiskarte Monitor Switch 4/2 1.915.602.81

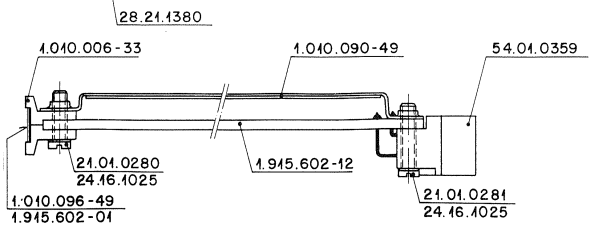
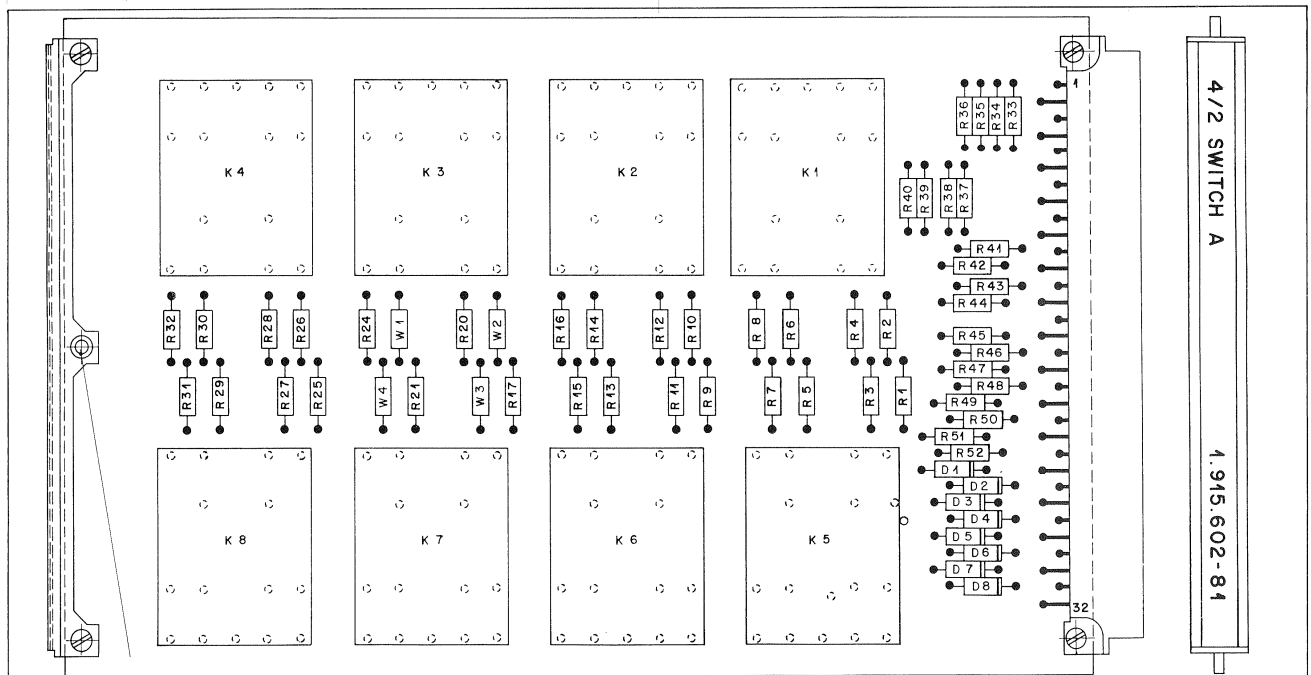

Werkstoff	Norm-Nr.	Oberfläche	Güte	Änderung	③
	DIN-Bez.:	Beh.:			②
Abmessung:					①
Zugehörige Unterlagen:	Freimasstoleranz:	Maßstab:	9:10.87	A.Ho	④
PL	±	2:1	Datum	Gez.	Gas
Ersatz für: 1.915.602-00		Ersetzt durch:	Kopie für:		
STUDER REGENSDORF ZÜRICH		Benennung: 4/2 SWITCH A		Nummer: 1.915.602-81	

Ad	..POS..	..REF.No..	DESCRIPTION.....	MANUFACTURER
D.....1	50.04.0125	1N4448	SILICIUM	
D.....2	50.04.0125	1N4448	SILICIUM	
D.....3	50.04.0125	1N4448	SILICIUM	
D.....4	50.04.0125	1N4448	SILICIUM	
D.....5	50.04.0125	1N4448	SILICIUM	
D.....6	50.04.0125	1N4448	SILICIUM	
D.....7	50.04.0125	1N4448	SILICIUM	
D.....8	50.04.0125	1N4448	SILICIUM	
K.....1	56.04.0146	4U/6V		NATIONAL/OMRON
K.....2	56.04.0146	4U/6V		NATIONAL/OMRON
K.....3	56.04.0146	4U/6V		NATIONAL/OMRON
K.....4	56.04.0146	4U/6V		NATIONAL/OMRON
K.....5	56.04.0146	4U/6V		NATIONAL/OMRON
K.....6	56.04.0146	4U/6V		NATIONAL/OMRON
K.....7	56.04.0146	4U/6V		NATIONAL/OMRON
K.....8	56.04.0146	4U/6V		NATIONAL/OMRON
R.....1	57.11.3562	5.6kΩ 1%		
R.....2	57.11.3562	5.6kΩ 1%		
R.....3	57.11.3562	5.6kΩ 1%		
R.....4	57.11.3562	5.6kΩ 1%		
R.....5	57.11.3562	5.6kΩ 1%		
R.....6	57.11.3562	5.6kΩ 1%		
R.....7	57.11.3562	5.6kΩ 1%		
R.....8	57.11.3562	5.6kΩ 1%		
R.....9	57.11.3562	5.6kΩ 1%		
R.....10	57.11.3562	5.6kΩ 1%		
R.....11	57.11.3562	5.6kΩ 1%		
R.....12	57.11.3562	5.6kΩ 1%		
R.....13	57.11.3562	5.6kΩ 1%		
R.....14	57.11.3562	5.6kΩ 1%		
R.....15	57.11.3562	5.6kΩ 1%		
R.....16	57.11.3562	5.6kΩ 1%		
R.....17	57.11.3562	5.6kΩ 1%		
R.....18	57.11.4109	1Ω		
R.....19	57.11.4109	1Ω		
R.....20	57.11.3562	5.6kΩ 1%		
R.....21	57.11.3562	5.6kΩ 1%		
R.....22	57.11.4109	1Ω		
R.....23	57.11.4109	1Ω		
R.....24	57.11.3562	5.6kΩ 1%		
R.....25	57.11.3562	5.6kΩ 1%		
R.....26	57.11.3562	5.6kΩ 1%		
R.....27	57.11.3562	5.6kΩ 1%		
R.....28	57.11.3562	5.6kΩ 1%		
R.....29	57.11.3562	5.6kΩ 1%		

Ad	..POS..	..REF.No..	DESCRIPTION.....	MANUFACTURER
R.....30	57.11.3562	5.6kΩ 1%		
R.....31	57.11.3562	5.6kΩ 1%		
R.....32	57.11.3562	5.6kΩ 1%		
R.....33		1MΩ		
R.....34		1MΩ		
R.....35		1MΩ		
R.....36		1MΩ		
R.....37		1MΩ		
R.....38		1MΩ		
R.....39		1MΩ		
R.....40		1MΩ		
R.....41		1MΩ		
R.....42		1MΩ		
R.....43		1MΩ		
R.....44		1MΩ		
R.....45		1MΩ		
R.....46		1MΩ		
R.....47		1MΩ		
R.....48		1MΩ		
R.....49		1MΩ		
R.....50		1MΩ		

STUDER (00) 87/10/26 4/2 SWITCH A 1.915.602.81

Monitor Relays 8/1

1.915.605

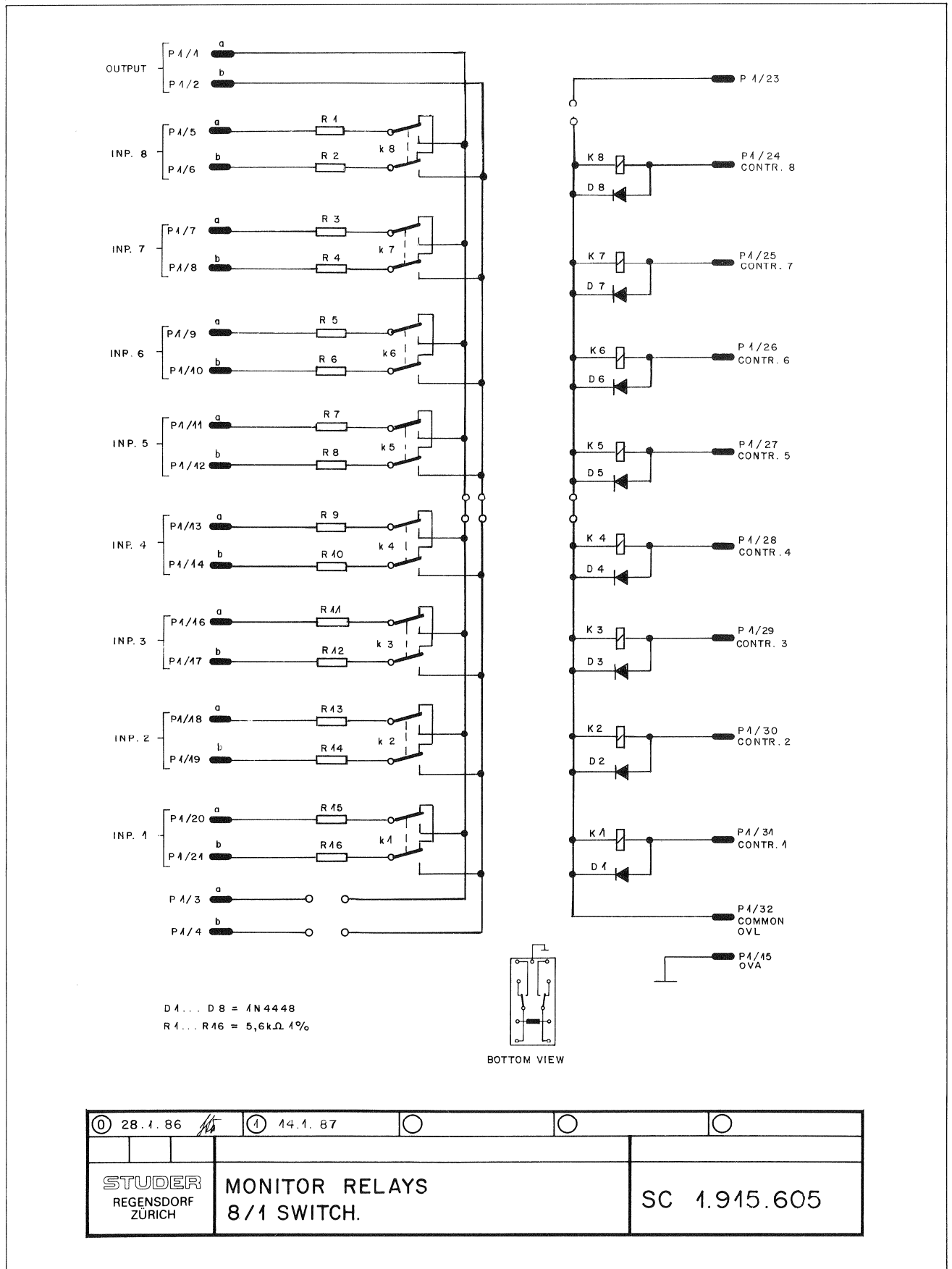

Monitor Relays 8/1 1.915.605

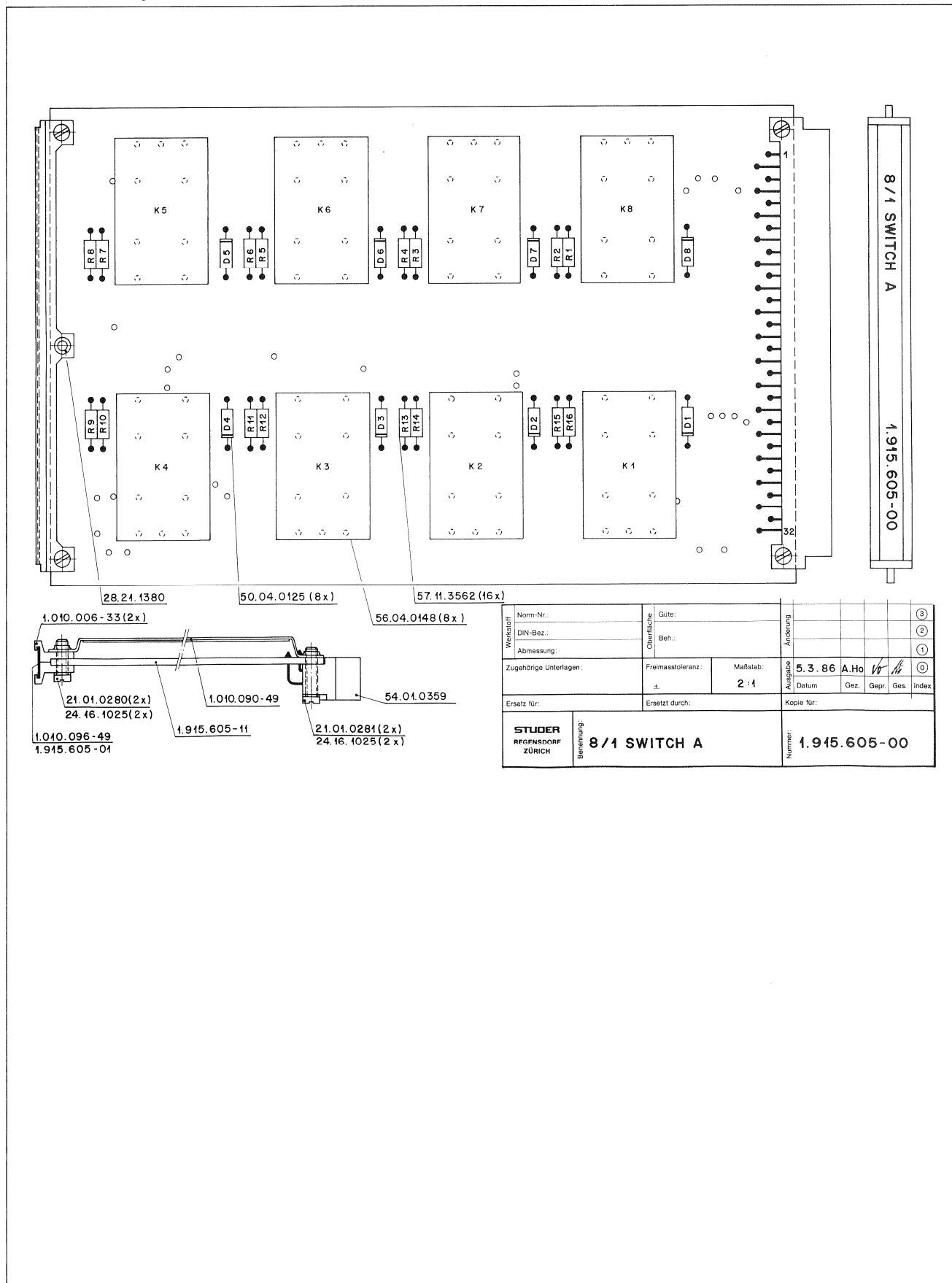

Verstärker:	Norm-Nr.:	Güte:	Änderung		③
DIN-Bez.:	Überfläche:	Beh.:			②
Abmessung:	Zugehörige Unterlagen:	Freimasstoleranz:	Maßstab:	5.3.86	①
		±	2:1	A.Ho	④
Ersatz für:	Ersetzt durch:	Kopie für:		Datum	Gez.
STUDER REGENSDORF ZÜRICH		Benennung: 8/1 SWITCH A		Gepr.	Index
		Nummer: 1.915.605-00		Ges.	