

D19 MultiDAC

8-Channel D/A Converter with MixMonitor

Serviceanleitung Service Instructions

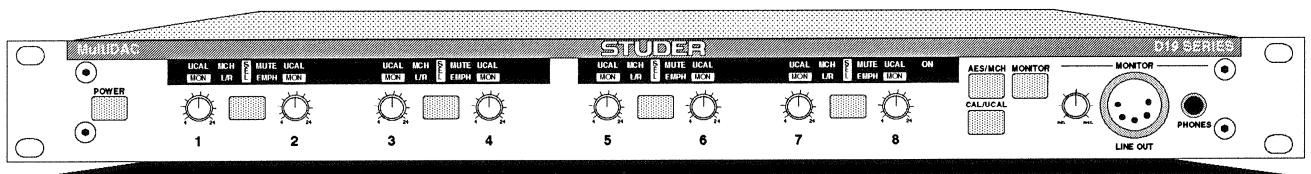

Prepared and edited by:
STUDER Professional Audio AG
Technical Documentation
Althardstrasse 30
CH-8105 Regensdorf - Switzerland

Copyright by STUDER Professional Audio AG
Printed in Switzerland
Order no. 10.27.4150 (Ed. 02/97)

Subject to change

STUDER is a registered trade mark of STUDER Professional Audio AG, Regensdorf

C A U T I O N
RISK OF ELECTRIC SHOCK DO NOT OPEN
A T T E N T I O N
RISQUE DE CHOC ELECTRIQUE NE PAS OUVRIR
A C H T U N G
GEFAHR: ELEKTRISCHER SCHLAG NICHT ÖFFNEN

To reduce the risk of electric shock, do not remove covers (or back). No user-serviceable parts inside. Refer servicing to qualified service personnel.

Afin de prévenir un choc électrique, ne pas enlever les couvercles (où l'arrière) de l'appareil. Il ne se trouve à l'intérieur aucune pièce pouvant être réparée par l'utilisateur.

Um die Gefahr eines elektrischen Schlages zu vermeiden, entfernen Sie keine Abdeckungen (oder Rückwand). Überlassen Sie die Wartung und Reparatur dem qualifizierten Fachpersonal.



This symbol is intended to alert the user to presence of uninsulated "**dangerous voltage**" within the apparatus that may be of sufficient magnitude to constitute a risk of electric shock to a person.

Ce symbole indique à l'utilisateur qu'il existe à l'intérieur de l'appareil des "**tensions dangereuses**". Ces tensions élevées entraînent un risque de choc électrique en cas de contact.

Dieses Symbol deutet dem Anwender an, dass im Geräteinnern die Gefahr der Berührung von "**gefährlicher Spannung**" besteht. Die Größe der Spannung kann zu einem elektrischen Schlag führen.



This symbol is intended to alert the user to the presence of **important instructions** for operating and maintenance in the enclosed documentation.

Ce symbole indique à l'utilisateur que la documentation jointe contient **d'importantes instructions** concernant le fonctionnement et la maintenance.

Dieses Symbol deutet dem Anwender an, dass die beigelegte Dokumentation **wichtige Hinweise** für Betrieb und Wartung beinhaltet.

FIRST AID

(in case of electric shock)

1. Separate the person as quickly as possible from the electric power source:
 - by switching off the equipment
 - or by unplugging or disconnecting the mains cable
 - pushing the person away from the power source by using dry insulating material (such as wood or plastic).
 - After having sustained an electric shock, always consult a doctor.

WARNING!

DO NOT TOUCH THE PERSON OR HIS CLOTHING BEFORE THE POWER IS TURNED OFF, OTHERWISE YOU STAND THE RISK OF SUSTAINING AN ELECTRIC SHOCK AS WELL!

2. If the person is unconscious
 - check the pulse,
 - reanimate the person if respiration is poor,
 - lay the body down, turn it to one side, call for a doctor immediately.

PREMIERS SECOURS

(en cas d'électrocution)

1. Si la personne est dans l'impossibilité de se libérer:
 - Couper l'interrupteur principal
 - Couper le courant
 - Repousser la personne de l'appareil à l'aide d'un objet en matière non conductrice (matière plastique ou bois)
 - Après une électrocution, consulter un médecin.

ATTENTION!

NE JAMAIS TOUCHER UNE PERSONNE QUI EST SOUS TENSION, SOUS PEINE DE SUBIR EGALLEMENT UNE ELECTROCUTION.

2. En cas de perte de connaissance de la personne électrocutée:
 - Contrôler le pouls
 - Si nécessaire, pratiquer la respiration artificielle
 - Placer l'accidenté sur le flanc et consulter un médecin.

ERSTE HILFE

(bei Stromunfällen)

1. Bei einem Stromunfall die betroffene Person so rasch wie möglich vom Strom trennen:
 - Durch Ausschalten des Gerätes
 - Ziehen oder Unterbrechen der Netzzuleitung
 - Betroffene Person mit isoliertem Material (Holz, Kunststoff) von der Gefahrenquelle wegstossen
 - Nach einem Stromunfall sollte immer ein Arzt aufgesucht werden.

ACHTUNG!

EINE UNTER SPANNUNG STEHENDE PERSON DARF NICHT BERÜHRT WERDEN. SIE KÖNNEN DABEI SELBST ELEKTRISIERT WERDEN!

2. Bei Bewusstlosigkeit des Verunfallten:
 - Puls kontrollieren,
 - bei ausgesetzter Atmung künstlich beatmen,
 - Seitenlagerung des Verunfallten vornehmen und Arzt verständigen.

Installation, Betrieb und Entsorgung

Vor der Installation des Gerätes müssen die hier aufgeführten und auch die weiter in dieser Anleitung mit \triangle bezeichneten Hinweise gelesen und während der Installation und des Betriebes beachtet werden.

Das Gerät und sein Zubehör ist auf allfällige Transportschäden zu untersuchen.

Ein Gerät, das mechanische Beschädigung aufweist oder in welches Flüssigkeit oder Gegenstände eingedrungen sind, darf nicht ans Netz angeschlossen oder muss sofort durch Ziehen des Netzsteckers vom Netz getrennt werden. Das Öffnen und Instandsetzen des Gerätes darf nur von Fachpersonal unter Einhaltung der geltenden Vorschriften durchgeführt werden.

Falls dem Gerät kein konfektioniertes Netzkabel beiliegt, muss dieses durch eine Fachperson unter Verwendung der mitgelieferten Kabel-Gerätedose IEC320/C13 oder IEC320/C19 und unter Berücksichtigung der einschlägigen, im jeweiligen Lande geltenden Bestimmungen angefertigt werden; siehe Bild unten.

Vor Anschluss des Netzkabels an die Netzsteckdose muss überprüft werden, ob die Stromversorgungs- und Anschlusswerte des Gerätes (Netzspannung, Netzfrequenz) innerhalb der erlaubten Toleranzen liegen. Die im Gerät eingesetzten Sicherungen müssen den am Gerät angebrachten Angaben entsprechen.

Ein Gerät mit einem dreipoligen Gerätestecker (Gerät der Schutzklasse I) muss an eine dreipolige Netzsteckdose angeschlossen und somit das Gerätegehäuse mit dem Schutzleiter der Netzinstallation verbunden werden (Für Dänemark gelten Starkstrombestimmungen, Abschnitt 107).

Installation, Operation, Disposal

Before you install the equipment, please read and adhere to the following recommendations and all sections of these instructions marked with \triangle .

Check the equipment for any transport damage.

A unit that is mechanically damaged or which has been penetrated by liquids or foreign objects must not be connected to the AC power outlet or must be immediately disconnected by unplugging the power cable. Repairs must only be performed by trained personnel in accordance with the applicable regulations.

Should the equipment be delivered without a matching mains cable, the latter has to be prepared by a trained person using the attached female plug (IEC320/C13 or IEC320/C19) with respect to the applicable regulations in your country - see diagram below.

Before connecting the equipment to the AC power outlet, check that the local line voltage matches the equipment rating (voltage, frequency) within the admissible tolerance. The equipment fuses must be rated in accordance with the specifications on the equipment.

Equipment supplied with a 3-pole appliance inlet (equipment conforming to protection class I) must be connected to a 3-pole AC power outlet so that the equipment cabinet is connected to the protective earth conductor of the AC supply (for Denmark the Heavy Current Regulations, Section 107, are applicable).

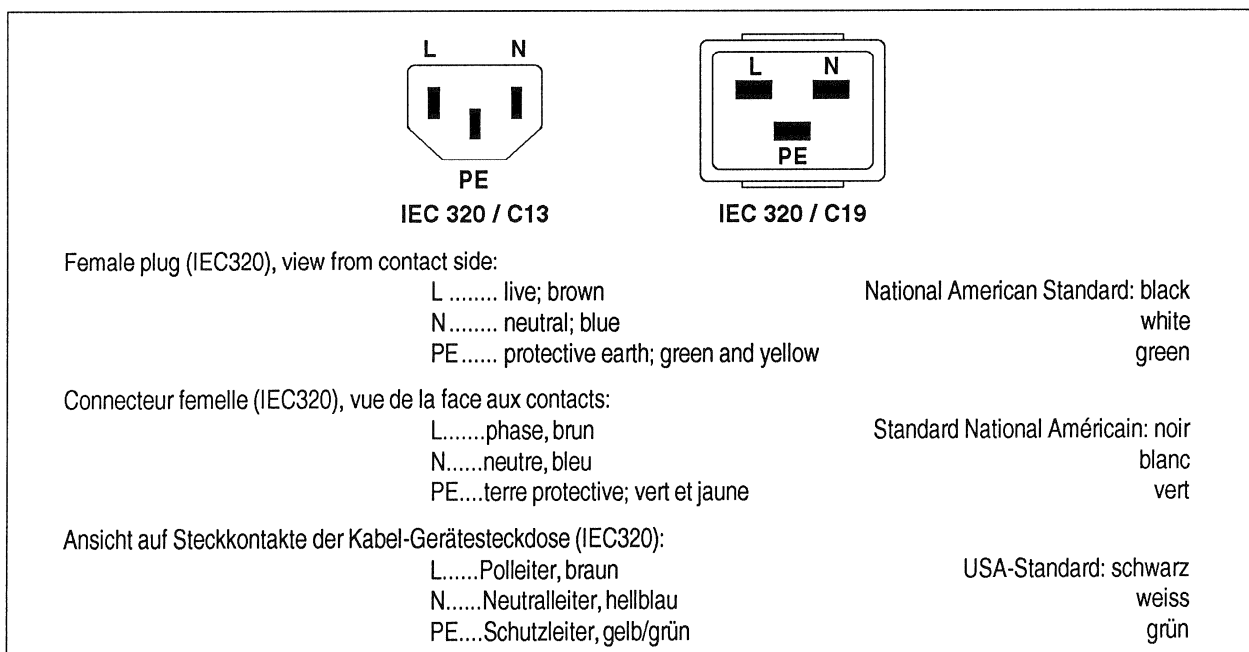

Bei der Installation des Gerätes muss **vermieden** werden, dass:

- das Gerät Regen, Feuchtigkeit, direkter Sonneneinstrahlung oder übermässiger Wärmestrahlung von Wärmequellen (Heizgeräte, Heizungen, Spotlampen) ausgesetzt wird
- die für den Betrieb des Gerätes benötigte Luftzirkulation beeinträchtigt und dadurch die zulässige maximale Lufttemperatur der Geräteumgebung überschritten wird (Wärmestau)
- die Belüftungsöffnungen des Gerätes blockiert oder abgedeckt werden.

Das Gerät und seine Verpackung darf nur sachgerecht entsorgt werden. Alle Teile des Gerätes, die gefährliche Stoffe (Quecksilber, Cadmium) enthalten, müssen als Sondermüll behandelt werden.

Verbrauchte Batterien und Akkus müssen dem Hersteller zur Entsorgung zurückgegeben oder entsprechend den spezifischen Bestimmungen Ihres Landes fachgerecht entsorgt werden.

Wartung und Reparatur

Durch Entfernen von Gehäuseteilen, Abschirmungen etc. werden stromführende Teile freigelegt. Aus diesem Grund müssen u.a. die folgenden Grundsätze beachtet werden: Eingriffe in das Gerät dürfen nur von Fachpersonal unter Einhaltung der geltenden Vorschriften vorgenommen werden.

Vor Entfernen von Gehäuseteilen muss das Gerät ausgeschaltet und vom Netz getrennt werden.

Bei geöffnetem, vom Netz getrenntem Gerät dürfen Teile mit gefährlichen Ladungen (z. B. Kondensatoren, Bildröhren) erst nach kontrollierter Entladung, heiße Bauteile (Leistungshalbleiter, Kühlkörper etc.) erst nach deren Abkühlen berührt werden.

Bei Wartungsarbeiten am geöffneten, unter Netzspannung stehenden Gerät dürfen blanke Schaltungsteile und metallene Halbleitergehäuse weder direkt noch mit einem nichtisolierten Werkzeug berührt werden.

Zusätzliche Gefahren bestehen bei unsachgemässer Handhabung besonderer Komponenten:

- **Explosionsgefahr** bei Lithiumzellen, Elektrolyt-Kondensatoren und Leistungshalbleitern
- **Implosionsgefahr** bei evakuierten Anzeigeeinheiten
- **Strahlungsgefahr** bei Lasereinheiten (nichtionisierend), Bildröhren (ionisierend)
- **Verätzungsgefahr** bei Anzeigeeinheiten (LCD) und Komponenten mit flüssigem Elektrolyt.

Solche Komponenten dürfen nur von dafür ausgebildetem Fachpersonal unter Verwendung von vorgeschriebenen Schutzmitteln (u.a. Schutzbrille, Handschuhe) gehandhabt werden.

The equipment installation **must satisfy** the following requirements:

- Protection against rain, humidity, direct solar irradiation or strong thermal radiation from heat sources (heaters, radiators, spotlights).
- Unobstructed air circulation so that the maximum air temperature in the equipment environment will not be exceeded (no heat accumulation).
- Ventilation louvers of the equipment must not be blocked or covered.

The equipment and its packing materials should ultimately be disposed of in accordance with the applicable regulations only. All parts of the equipment that contain hazardous substances (mercury, cadmium) must be treated as toxic waste.

Weak batteries or exhausted rechargeable batteries must be returned to the manufacturer for competent disposal or must be disposed of in accordance with the environmental protection regulations applicable for your country.

Maintenance and Repair

The removal of housing parts, shields, etc. exposes energized parts. For this reason the following precautions should be observed:

Maintenance should only be performed by trained personnel in accordance with the applicable regulations. The equipment should be switched off and disconnected from the AC power outlet before any housing parts are removed.

Even after the equipment has been disconnected from the power, parts with hazardous charges (e.g. capacitors, picture tubes) should only be touched after they have been properly discharged. Hot components (power semiconductors, heat sinks, etc.) should only be touched after they have cooled off.

If maintenance is performed on a unit that is opened and switched on, no uninsulated circuit components and metallic semiconductor housings should be touched neither with your bare hands nor with uninsulated tools.

Certain components pose additional hazards:

- **Explosion hazard** from lithium batteries, electrolytic capacitors and power semiconductors
- **Implosion hazard** from evacuated display units
- **Radiation hazard** from laser units (non-ionizing), picture tubes (ionizing)
- **Caustic effect** of display units (LCD) and such components containing liquid electrolyte.

Such components should only be handled by trained personnel who are properly protected (e.g. by goggles, gloves).

Für Wartung und Reparatur der sicherheitsrelevanten Teile des Gerätes darf nur Ersatzmaterial nach Herstellerspezifikation verwendet werden.

Das Gerät muss ordnungsgemäss und regelmässig gewartet und somit in sicherem Zustand erhalten werden. Bei ungenügender Wartung oder bei Änderungen der sicherheitsrelevanten Teile des Gerätes erlischt die entsprechende Produkthaftung des Herstellers.

For maintenance work and repair on components that influence the equipment safety, only replacement material conforming to the manufacturer's specifications may be used.

The equipment should be properly serviced in regular intervals and be maintained in safe operating condition. If the equipment is not properly maintained or if any modifications are made to components that influence safety, the manufacturer's product liability gets void.

Elektrostatische Entladung (ESD) bei Wartung und Reparatur

Electrostatic Discharge (ESD) during Maintenance and Repair

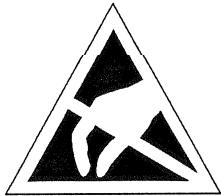

ATTENTION: Observe precautions for handling devices sensitive to electrostatic discharge!

ATTENTION: Respecter les précautions d'usage concernant la manipulation de composants sensibles à l'électricité statique!

ACHTUNG: Vorsichtsmassnahmen bei Handhabung elektrostatisch entladungsgefährdeter Bauelemente beachten!

Viele ICs und andere Halbleiter sind empfindlich gegen elektrostatische Entladung (ESD). Unfachgerechte Behandlung von Baugruppen mit solchen Komponenten bei Wartung und Reparatur kann deren Lebensdauer drastisch vermindern.

Bei der Handhabung der ESD-empfindlichen Komponenten sind u.a. folgende Regeln zu beachten:

- ESD-empfindliche Komponenten dürfen ausschliesslich in dafür bestimmten und bezeichneten Verpackungen gelagert und transportiert werden.
- Unverpackte, ESD-empfindliche Komponenten dürfen nur in den dafür eingerichteten Schutzzonen (EPA, z.B. Gebiet für Feldservice, Reparatur- oder Serviceplatz) gehandhabt und nur von Personen berührt werden, die durch ein Handgelenkband mit Serienwiderstand mit dem Massepotential des Reparatur- oder Serviceplatzes verbunden sind. Das gewartete oder reparierte Gerät wie auch Werkzeuge, Hilfsmittel, EPA-taugliche (elektrisch halbleitende) Arbeits-, Ablage- und Bodenmatten müssen ebenfalls mit diesem Potential verbunden sein.
- Die Anschlüsse der ESD-empfindlichen Komponenten dürfen unkontrolliert weder mit elektrostatisch aufladbaren (Gefahr von Spannungsdurchschlag), noch mit metallischen Oberflächen (Schockentladungsgefahr) in Berührung kommen.
- Um undefinierte transiente Beanspruchung der Komponenten und deren eventuelle Beschädigung durch unerlaubte Spannung oder Ausgleichsströme zu vermeiden, dürfen elektrische Verbindungen nur am abgeschalteten Gerät und nach dem Abbau allfälliger Kondensatorladungen hergestellt oder getrennt werden.

Many ICs and semiconductors are sensitive to electrostatic discharge (ESD). The life of components containing such elements can be drastically reduced by improper handling during maintenance and repair work.

Please observe the following rules when handling ESD sensitive components:

- ESD sensitive components should only be stored and transported in the packing material specifically provided for this purpose.
- Unpacked ESD sensitive components should only be handled in ESD protected areas (EPA, e.g. area for field service, repair or service bench) and only be touched by persons who wear a wristlet that is connected to the ground potential of the repair or service bench by a series resistor. The equipment to be repaired or serviced and all tools, aids, as well as electrically semiconducting work, storage and floor mats should also be connected to this ground potential.
- The terminals of ESD sensitive components must not come in uncontrolled contact with electrostatically chargeable (voltage puncture) or metallic surfaces (discharge shock hazard).
- To prevent undefined transient stress of the components and possible damage due to inadmissible voltages or compensation currents, electrical connections should only be established or separated when the equipment is switched off and after any capacitor charges have decayed.

SMD-Bauelemente

Der Austausch von SMD-Bauelementen ist ausschliesslich geübten Fachleuten vorbehalten. Für verwüstete Platinen können keine Ersatzansprüche geltend gemacht werden. Beispiele für korrekte und falsche SMD-Lötverbindungen in der Abbildung weiter unten.

Bei Studer werden keine handelsüblichen SMD-Teile bewirtschaftet. Für Reparaturen sind die notwendigen Bauteile lokal zu beschaffen. Die Spezifikationen von Spezialbauteilen finden Sie in der Serviceanleitung.

SMD Components

SMDs should only be replaced by skilled specialists. No warranty claims will be accepted for circuit boards that have been ruined. Proper and improper SMD soldering joints are depicted below.

Studer does not keep any commercially available SMDs in stock. For repair the corresponding devices should be purchased locally. The specifications of special components can be found in the service manual.

	<p>LötKolben/Soldering iron</p>	
<p>Demontage/Dismounting</p>		
<p>Montage/Mounting</p>	<p>Beispiele/Examples</p>	

Störstrahlung und Störfestigkeit

Das Gerät entspricht den Schutzanforderungen auf dem Gebiet der elektromagnetischen Phänomene, die u.a. in den Richtlinien 89/336/EWG und FCC, Part 15, aufgeführt sind :

1. Die vom Gerät erzeugten elektromagnetischen Aussendungen sind soweit begrenzt, dass ein bestimmungsgemässer Betrieb anderer Geräte und Systeme möglich ist.
2. Das Gerät weist eine angemessene Festigkeit gegen elektromagnetische Störungen auf, so dass sein bestimmungsgemässer Betrieb möglich ist.

Das Gerät wurde getestet und erfüllt die Bedingungen der im Kapitel „Technische Daten“ aufgeführten EMV-Standards. Die Limiten dieser Standards gewährleisten mit einer angemessenen Wahrscheinlichkeit sowohl einen Schutz der Umgebung wie auch entsprechende Störfestigkeit des Gerätes. Eine absolute Garantie, dass keine unerlaubte elektromagnetische Beeinträchtigung während des Gerätebetriebes entsteht, ist jedoch nicht gegeben. Um die Wahrscheinlichkeit solcher Beeinträchtigung weitgehend auszuschliessen, sind u.a. folgende Massnahmen zu beachten:

- Installieren Sie das Gerät gemäss den Angaben in der Bedienungsanleitung, und verwenden Sie das mitgelieferte Zubehör.
- Verwenden Sie im System und in der Umgebung, in denen das Gerät eingesetzt ist, nur Komponenten (Anlagen, Geräte), die ihrerseits die Anforderungen der obenerwähnten Standards erfüllen.
- Sehen Sie ein Erdungskonzept des Systems vor, das sowohl die Sicherheitsanforderungen (die Erdung der Geräte gemäss Schutzklasse I mit einem Schutzleiter muss gewährleistet sein), wie auch die EMV-Belange berücksichtigt. Bei der Entscheidung zwischen stern- oder flächenförmiger bzw. kombinierter Erdung sind Vor- und Nachteile gegeneinander abzuwägen.
- Benutzen Sie abgeschirmte Kabel für die Verbindungen, für welche eine Abschirmung vorgesehen ist. Achten Sie auf einwandfreie, grossflächige, korrosionsbeständige Verbindung der Abschirmung zum entsprechenden Steckeranschluss bzw. zum Steckergehäuse. Beachten Sie, dass eine nur an einem Ende angeschlossene Kabelabschirmung als Sende- bzw. Empfangsantenne wirken kann (z.B. bei wirksamer Kabellänge von 5 m oberhalb von 10 MHz), und dass die Flanken der digitalen Kommunikationssignale hochfrequente Aussendungen verursachen (z.B. LS- oder HC-Logik bis 30 MHz).
- Vermeiden Sie Bildung von Stromschleifen oder vermindern Sie deren unerwünschte Auswirkung, indem Sie deren Fläche möglichst klein halten und den darin fliessenden Strom durch Einfügen einer Impedanz (z.B. Gleichtaktdrossel) reduzieren.

Electromagnetic Compatibility

The equipment conforms to the protection requirements relevant to electromagnetic phenomena that are listed in the guidelines 89/336/EC and FCC, part 15.

1. The electromagnetic interference generated by the equipment is limited in such a way that other equipment and systems can be operated normally.
2. The equipment is adequately protected against electromagnetic interference so that it can operate correctly.

The unit has been tested and conforms to the EMC standards applicable to residential, commercial and light industry, as listed in the section „Technical Data“. The limits of these standards reasonably ensure protection of the environment and corresponding noise immunity of the equipment. However, it is not absolutely warranted that the equipment will not be adversely affected by electromagnetic interference during operation.

To minimize the probability of electromagnetic interference as far as possible, the following recommendations should be followed:

- Install the equipment in accordance with the operating instructions. Use the supplied accessories.
- In the system and in the vicinity where the equipment is installed, use only components (systems, equipment) that also fulfill the above EMC standards.
- Use a system grounding concept that satisfies the safety requirements (protection class I equipment must be connected with a protective ground conductor) that also takes into consideration the EMC requirements. When deciding between radial, surface or combined grounding, the advantages and disadvantages should be carefully evaluated in each case.
- Use shielded cables where shielding is specified. The connection of the shield to the corresponding connector terminal or housing should have a large surface and be corrosion-proof. Please note that a cable shield connected only single-ended can act as a transmitting or receiving antenna (e.g. with an effective cable length of 5 m, the frequency is above 10 MHz) and that the edges of the digital communication signals cause high-frequency radiation (e.g. LS or HC logic up to 30 MHz).
- Avoid current loops or reduce their adverse effects by keeping the loop surface as small as possible, and reduce the noise current flowing through the loop by inserting an additional impedance (e.g. common-mode rejection choke).

Class A Equipment - FCC Notice

This equipment has been tested and found to comply with the limits for a Class A digital device, pursuant to Part 15 of the FCC Rules. These limits are designed to provide a reasonable protection against harmful interference when the equipment is operated in a commercial environment. This equipment generates, uses, and can radiate radio frequency energy and, if not installed and used in accordance with the instruction manual, may cause harmful interference to radio communications. Operation of this equipment in a residential area is likely to cause harmful interference in which case the user will be required to correct the interference at his own expense.

Caution:

Any changes or modifications not expressly approved by the manufacturer could void the user's authority to operate the equipment. Also refer to relevant information in this manual.

CE-Konformitätserklärung

Wir,

Studer Professional Audio AG,
CH-8105 Regensdorf,

erklären in eigener Verantwortung, dass das Produkt

Studer D19 MultiDAC, 8-Channel D/A Converter
(ab Serie-Nr. 1001),

auf das sich diese Erklärung bezieht, entsprechend den Bestimmungen der EU-Richtlinien und deren Ergänzungen

- Elektromagnetische Verträglichkeit (EMV):
89/336/EWG + 92/31/EWG + 93/68/EWG
- Niederspannung:
73/23/EWG, 93/68/EWG

mit den folgenden Normen und normativen Dokumenten übereinstimmt:

- Sicherheit:
Schutzklasse I, EN 60950; 1992 + A1, A2; 1993
- EMV:
EN 50081-1; 1992, EN 50082-1; 1992

Regensdorf, 3. September 1996



B. Hochstrasser, Geschäftsleiter



P. Fiala, Leiter QS

CE Declaration of Conformity

We,

Studer Professional Audio AG,
CH-8105 Regensdorf,

declare under our sole responsibility that the product

Studer D19 MultiDAC, 8-Channel D/A Converter
(from serial No. 1001 and up),

to which this declaration relates, according to following regulations of EU directives and amendments

- Electromagnetic Compatibility (EMC):
89/336/EEC + 92/31/EEC + 93/68/EEC
- Low Voltage (LVD):
73/23/EEC + 93/68/EEC

is in conformity with the following standards or other normative documents:

- Safety:
Class I, EN 60950; 1992 + A1, A2; 1993
- EMC:
EN 50081-1; 1992, EN 50082-1; 1992

Regensdorf, September 3, 1996



B. Hochstrasser, Managing Director



P. Fiala, Manager QA

INHALT

1	Hereinspaziert!	D1/1
1.1	Basis-Information	D1/1
1.2	Allgemeines	D1/2
1.2.1	Lieferumfang	D1/2
1.2.2	Optionen	D1/2
1.2.3	Zubehör	D1/2
1.3	Sicherheit und Anschlüsse	D1/3
1.3.1	Bestimmungsgemässe Verwendung	D1/3
1.3.2	Netzanschluss	D1/3
1.3.3	Anschlussfeld	D1/4
1.4	Technische Daten	D1/5
1.4.1	Audiodaten	D1/5
1.4.2	Stromversorgung	D1/5
1.4.3	Primärsicherung	D1/5
1.4.4	Betriebsbedingungen	D1/6
1.4.5	Sicherheits- und EMV-Normen	D1/6
1.4.6	Mechanische Daten	D1/6
2	Betrieb	D2/1
2.1	Bedienungselemente	D2/1
2.2	Audio-Anschlüsse, Stiftbelegungen	D2/3
2.2.1	AES/EBU, Digital-Eingang	D2/3
2.2.2	Line-Ausgänge	D2/3
2.2.3	MONITOR Phones	D2/3
2.2.4	MONITOR LINE OUT	D2/3
2.2.5	Anwendung der 8-Kanal-TDIF-1-Schnittstelle	D2/4
2.2.6	Anwendung der 8-Kanal-ADAT-Schnittstelle	D2/5
3	Service	D3/1
3.1	Benötigte Hilfsmittel	D3/1
3.2	Einbau von Achtkanal-Schnittstellen	D3/1
3.3	Jumpers	D3/2
3.3.1	Auto Mute	D3/2
3.3.2	Synchronisation	D3/2
3.4	Einstellungen	D3/3
3.4.1	Ausgangspegel für kalibrierten Betrieb (CAL)	D3/3
3.4.2	Subrange-Linearität	D3/3
3.5	Ersatzteile	D3/4
4	Schemas	

«ADAT» ist ein Warenzeichen von Alesis Corporation.

«TDIF-1» ist ein Warenzeichen von Tascam Corporation.

I **HEREINSPAZIERT!**

Wir freuen uns, Sie im wachsenden Kreis der Anwender des Studer D19 MultiDAC begrüßen zu dürfen, und beglückwünschen Sie zu Ihrer Wahl. Dank der Erfahrung, die Studer während mehr als 40 Jahren auf dem Gebiet der professionellen Audiotechnik sammeln konnte, dürfen Sie erwarten, dass Ihr neues Gerät Ihre hohen Ansprüche erfüllt.

I.1 **Basis-Information**

Der Studer D19 MultiDAC enthält acht D/A-Wandler mit einer Auflösung von 23 bit. Zusätzlich zu den normalen Wandler-Funktionen wurden nützliche Erweiterungen integriert, daher finden sich auf der Frontplatte einige einfache, ergonomisch ausgelegte Bedienelemente. Acht Potentiometer dienen einer doppelten Funktion: Zur Einstellung des Ausgangspegels (in unkalibriertem Betrieb) oder zur Einstellung eines Monitorpegels. LED-Anzeigen für Signalqualität (MUTE) und De-emphasis-Flag (EMPH) sind ebenfalls vorgesehen. In einem zentralen Bedienfeld können die digitale Quelle (AES/MCH) und die CAL/UCAL-Funktion gewählt werden. Mit einer SElect-Taste pro Wandlerpaar kann dieses zur Bedienung durch dieses zentrale Bedienfeld aufgeschaltet werden.

MixMonitor: Neben einer hochqualitativen Wandlung von Digitalsignalen besteht oft auch der Wunsch, das gewandelte Signal optimal abhören zu können. Mit Hilfe der MixMonitor-Funktion können die acht Eingangssignale (vier AES/EBU-Paare) mono oder stereo abgehört werden; auch eine individuelle Mischung ist möglich. Die zugehörigen Bedienelemente befinden sich auf der rechten Seite der Frontplatte und umfassen neben dem Lautstärke-Drehknopf einen Kopfhöreranschluss und einen 5-poligen XLR-Stecker (elektronisch symmetriertes Stereo-Signal mit Leitungspegel). MixMonitor hat eine ganze Reihe von Einsatzmöglichkeiten, wie z.B. direkte Hinterbandkontrolle von Achtspur-Digitalrecordern. Daneben lassen sich einzelne Kanäle abhören oder messen. In der kalibrierten Stellung der einzelnen Ausgänge beeinflusst die Einstellung des Abhörweges den Ausgangspegel nicht. Der MultiDAC ist daher nicht nur ein hochwertiger D/A-Wandler, sondern auch ein Achtkanal-Mischer.

Anschlüsse: Zur Vereinfachung der Systemverbindungen ist der MultiDAC mit den selben Anschlüssen wie sein Bruder, der MicAD, ausgerüstet. Standardmässig ist das Gerät mit vier AES/EBU-Eingängen bestückt, ADAT- oder TDIF-1-kompatible Eingänge stehen als Option zur Verfügung. Jedes Eingangs-Kanalpaar kann individuell entweder von seinem AES/EBU-Anschluss oder von den entsprechenden Kanälen des Mehrkanal-Anschlusses mit Signal versorgt werden. Die acht analogen Ausgänge sind transformator-symmetriert und auf einzelne XLR-Stecker geführt.

Synchronisation: Die acht D/A-Wandler arbeiten in einem weiten Abtastraten-Bereich; ein externes Synchronisationssignal ist nicht erforderlich, da jeder Eingang seinen eigenen, asynchronen Abtastratenwandler enthält. Falls notwendig, kann jeder der Eingänge mit einer unabhängigen Abtast-

rate arbeiten. Soll aus Systemgründen ein fester Takt gewählt werden, kann der MultiDAC intern so eingestellt werden, dass ein beliebiger Eingang (AES/EBU oder Mehrkanal) als feste Referenz für alle D/A-Wandler dient; auf diese Weise können allfällige Phasenfehler vermieden werden.

I.2 Allgemeines

I.2.1 Lieferumfang

Der D19 MultiDAC (Bestell-Nr. 66.660.000.00) wird mit einer Kaltgärtekupplung (IEC 320/C13), einem Inbus-Schraubendreher (2,5 mm) und dieser Betriebsanleitung geliefert.

I.2.2 Optionen

Bestell-Nr.

Optionale Digital-Audio-Eingänge:

ADAT-Schnittstelle:	8-kanalige, optische Digitalaudio-Eingangskarte für den Anschluss von ADAT- und kompatiblen Achtspur-Bandgeräten oder anderen Geräten, die mit den ADAT-Standardanschlüssen ausgestattet sind.	1.660.050.20
TDIF-1-Schnittstelle:	8-kanalige Digitalaudio-Eingangskarte für den Anschluss von DA-88- und kompatiblen Achtspur-Bandgeräten oder anderen Geräten, die mit den TDIF-1-Standardanschlüssen ausgestattet sind.	1.660.052.20

I.2.3 Zubehör

Bestell-Nr.

Zubehör und Ersatzteile:	Set, bestehend aus: <ul style="list-style-type: none"> • XLR-Steckverbinder (4 Stecker und 8 Kupplungen dreipolig, 1 Kupplung 5-polig) • Drehknöpfe (2 Stück) • Schrauben und Unterlegscheiben für Rackeinbau (je 4 Stück) 	20.020.302.52
Schnittstellenkabel:	ADAT/Alesis, optisches Verbindungskabel, Länge 1,0 m	10.325.010.00
	ADAT/Alesis, optisches Verbindungskabel, Länge 5,0 m	10.325.011.00
	TDIF-1/Tascam-Verbindungskabel «PW 88D», Länge 1,0 m	F-10.025.031.08
	TDIF-1/Tascam-Verbindungskabel «PW 88D», Länge 5,0 m	F-10.025.031.09

I.3 Sicherheit und Anschlüsse

I.3.1 Bestimmungsgemässe Verwendung



Der Studer D19 MultiDAC ist für den professionellen Betrieb konzipiert. Es wird vorausgesetzt, dass das Gerät ausschliesslich durch dafür geschulte Personen bedient und durch Fachpersonal gewartet wird. *Die elektrischen Anschlüsse dürfen nur mit den in dieser Betriebsanleitung bezeichneten Spannungen und Signalen verbunden werden. Bitte lesen Sie dazu auch die Abschnitte «Sicherheit» und «EMV» in der Einleitung dieser Betriebsanleitung.*

I.3.2 Netzanschluss

Das Gerät hat keinen Spannungswähler. Es kann mit beliebigen Wechselspannungen im Bereich von 100 bis 240 V_{AC}, 50 bis 60 Hz, betrieben werden.

Wichtig!

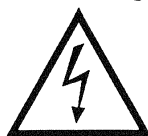

Eingriffe im Inneren des Gerätes dürfen nur von geschulten Service-Technikern vorgenommen werden. Sicherungen dürfen nur durch solche des selben Typs ersetzt werden. Das Gerät darf vom Benutzer nicht geöffnet werden – Risiko eines gefährlichen elektrischen Schlages!

Netzkabel:



Die mitgelieferte Kaltgerätedose muss durch einen Elektriker mit einem passenden Netzkabel mit Netzstecker versehen werden, wenn Ihre lokale Studer-Vertretung oder Ihr Fachhändler kein passendes Netzkabel beigelegt hat.

- Bitte lesen Sie dazu den Abschnitt «Sicherheit» in der Einleitung dieser Betriebsanleitung.

I.3.3 Anschlussfeld

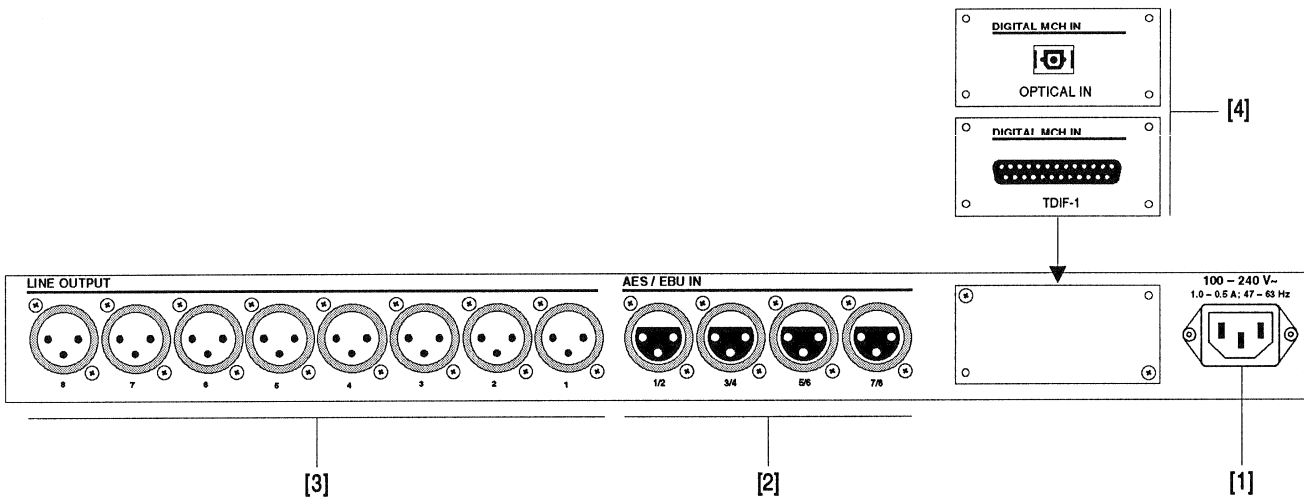

[1] 100 – 240 V

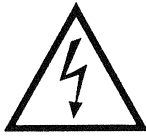

Anschluss für Kaltgeräte-Kabeldose IEC 320/C13.

Netzspannungsbereich 100...240 V_{AC} (ohne Spannungswähler);
Netzfrequenz 50...60 Hz.

Vor dem Anschliessen ans Netz lesen Sie bitte die Seiten «Sicherheit»
ganz am Anfang dieser Anleitung.

[2] AES/EBU IN

Eingänge für vier digitale Eingangssignale gemäss AES/EBU, mit weiblichem XLR-Anschluss.

[3] LINE OUTPUTS

Analoge Line-Ausgänge mit männlichen XLR-Anschlüssen. Ausgangs-
impedanz $\leq 40 \Omega$, transformator-symmetriert.

[4] MCH IN

Optionale, digitale Mehrkanal-Eingänge; wahlweise TDIF-1-Achtkanal-
Format oder optisches ADAT-Achtkanal-Format.

I.4 Technische Daten (Änderungen vorbehalten)

I.4.1 Audiodaten (20 Hz...20 kHz, bei +15 dBu_{FS}, wenn nicht anders spezifiziert)

D/A-Wandlung: Auflösung 23 bit, linear.

LINE OUTPUT:

Frequenzgang: $\pm 0,1$ dB

Geräuschspannungsabstand: > 115 dB, unbewertet, Auto Mute OFF, +24 dBu_{FS}
> 119 dB, unbewertet, Auto Mute ON, +24 dBu_{FS}

THD+N: < -80 dB_{FS}, bei 0 dB_{FS}
< -110 dB_{FS} (typ. -112 dB_{FS}), bei -30 dB_{FS}

Übersprechen: < -95 dB (typ. -100 dB)
< -110 dB, 1 kHz

Ausgangsimpedanz: typ. < 30 Ω
max. < 40 Ω

Maximaler Ausgangspegel: typ. 24 dBu (Last 100 k Ω)
typ. 23,5 dBu (Last 600 Ω)

MONITOR OUTPUT:

Frequenzgang: $\pm 0,1$ dB

THD+N: < -80 dB_{FS}, bei 0 dB_{FS}, 1 kHz
< -110 dB_{FS} (typ. -112 dB_{FS}), bei -30 dB_{FS}, 1 kHz

Ausgangsimpedanz: < 50 Ω (LINE OUT)
100 Ω (PHONES)

Maximaler Ausgangspegel: typ. 24 dBu (Last 100 k Ω)
typ. 23,5 dBu (Last 600 Ω)

I.4.2 Stromversorgung

Netzspannung: 100...240 V_{AC}, 50...60 Hz

Stromaufnahme: 1...0,5 A

Netzanschluss: IEC 320/C14

I.4.3 Primärsicherung



Gefahr: Die Primärsicherung ist im Inneren des Gerätes angeordnet. Eingriffe im Inneren des Gerätes dürfen nur von geschulten Service-Technikern vorgenommen werden. Die Sicherung darf nur durch eine solche des selben Typs ersetzt werden. Das Gerät darf vom Benutzer nicht geöffnet werden – Risiko eines gefährlichen elektrischen Schlages!

Ersatztyp: T 2,0 A H 250 V UL, CSA (5 × 20 mm)

Bestell-Nr. 51.01.1022

I.4.4 Betriebsbedingungen

Umgebungstemperatur: +10°...+40°C

Rel. Luftfeuchtigkeit: Klasse F (DIN 40040)

I.4.5 Sicherheits- und EMV-Normen

Sicherheit: Schutzklasse I gemäss EN 60950; 1992 + A1/A2; 1993 (UL 1950)

EMV: Produktfamilienorm für Audio-, Video- und audiovisuelle Einrichtungen sowie für Studio-Lichtsteuereinrichtungen für den professionellen Einsatz.

Störaussendung: EN 50081-1; 1992

Störfestigkeit: EN 50082-1; 1992

I.4.6 Mechanische Daten

Gewicht: ca. 5 kg

Abmessungen: [mm]

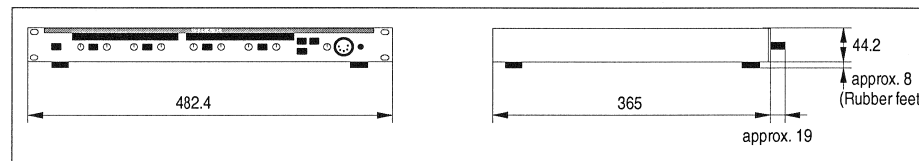

2 BETRIEB

2.1 Bedienungselemente

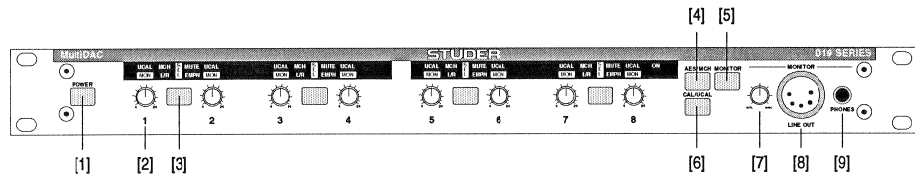

[1] POWER Versenkte Drucktaste, schaltet das Gerät ein und aus. Während der Initialisierungsphase (einige Sekunden nach dem Einschalten) sind die Ausgänge stummgeschaltet, alle SEL-LEDs blinken, und alle Tasten sind gesperrt. Ist das Gerät eingeschaltet, so leuchtet zumindest die gelbe ON-LED rechts im rechten Anzeigefenster. Das Gerät ist mit den Werkseinstellungen betriebsbereit. Geräteeinstellungen bleiben auch nach dem Ausschalten in einem Flash-EPROM erhalten; das Gerät benötigt keine Stützbatteie.

[2] Potentiometer 1...8 Potentiometer mit Mehrfachfunktion:
MixMonitor: Jeder der Kanäle kann jederzeit den Monitor-Ausgängen zugeschaltet und -gemischt werden – abhängig von der Einstellung MONITOR [5] – entweder beiden oder nur einem der Monitor-Kanäle. Einstellbereich: 20 dB am Potentiometer [2].
UCAL: In Stellung UCAL beeinflussen die Potentiometer sowohl den Pegel des Ausgangs mit der selben Nummer (Einstellbereich: +4...+24 dBu bei 0 dB_{FS}) wie auch den Monitor-Mix. Siehe auch CAL/UCAL [6].

Headroom: Die Einstellung für den Ausgangspegel ist in dBu für Vollaussteuerung angegeben; ein Eingangssignal mit 0 dB_{FS} bewirkt Vollaussteuerung am Ausgang des D/A-Wandlers. Damit die Pegelverhältnisse im Systemverbund mit A/D-Wandlern und anderen Studiogeräten gewährt bleiben, kann bzw. muss eine Übersteuerungsreserve (Headroom) eingestellt werden.

Beispiel: Nominalpegel im Studio +6 dBu, die gewünschte Übersteuerungsreserve beträgt 12 dB; der *Spitzenpegel* bei 0 dB_{FS} beträgt also +18 dBu; Einstellung im unkalibrierten Betrieb (UCAL leuchtet) mit Potentiometer [2].
 Siehe auch CAL/UCAL [6].

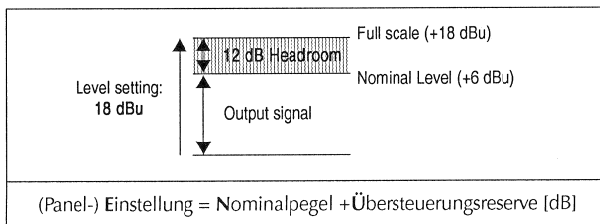

[3] SEL Tasten zur Zuordnung der globalen Funktionstasten (AES/MCH [4], MONITOR [5], CAL/UCAL [6]) zu den Kanalpaaren.

SEL-Taste des gewünschten Kanals drücken (oder eine SEL-Taste gedrückt lassen und SEL-Tasten von weiteren, zusätzlich gewünschten Kanälen drücken), die betreffenden gelben SEL-LEDs leuchten. Die Funktionstasten AES/MCH, MONITOR, CAL/UCAL bewirken nun Umschaltung der entsprechenden Funktion. Ein zweiter Druck auf eine SEL-Taste schaltet die Zuordnung und die LED wieder aus.

[4] AES/MCH

Umschalten des mit SEL [3] vorgewählte Kanalpaars vom AES/EBU-Eingang auf das entsprechende Kanalpaar des MCH-Einganges (MCH-LED leuchtet); falls kein MCH-Interface bestückt ist oder kein Eingangssignal anliegt, leuchtet die rote MUTE-LED.

[5] MONITOR

Wahl des Abhör-Modus der beiden Ausgänge LINE OUT und PHONES. Ist ein Kanalpaar mit SEL vorgewählt, können mit der MONITOR-Taste fünf Zustände zyklisch abgerufen werden:

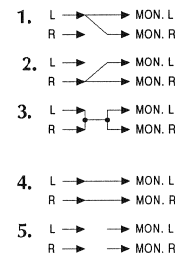

1. L → MON. L
R → MON. R
Abhören nur des linken Kanals (z.B. Kanal 1) auf beiden Abhör-Kanälen (grüne MON-LED von Kanal 1 leuchtet);
2. L → MON. L
R → MON. R
Abhören nur des rechten Kanals (z.B. Kanal 2) auf beiden Abhör-Kanälen (grüne MON-LED von Kanal 2 leuchtet);
3. L → MON. L
R → MON. R
Abhören des linken und des rechten Kanals zu einem Mono-Signal summiert auf beiden Abhör-Kanälen (grüne MON-LEDs der Kanäle 1 und 2 leuchten);
4. L → MON. L
R → MON. R
Zweikanaliges Abhören des linken und des rechten Kanales (grüne LED L/R und grüne MON-LEDs der Kanäle 1 und 2 leuchten);
5. L → MON. L
R → MON. R
Kein Abhören des linken und des rechten Kanales (beide MON-LEDs sind dunkel).

[6] CAL/UCAL

Die Potentiometer [1] bis [8] für die PegelEinstellung der einzelnen Kanäle können mit UCAL aktiviert werden (gelbe LEDs UCAL leuchten); Einstellbereich +4...+24 dBu bei 0 dB_{FS}. Falls sie nicht aktiviert sind, ist der Pegel aller Ausgänge mit Ausnahme der MONITOR-Ausgänge LINE OUT und PHONES fest.

Beispiel: Nominalpegel im Studio +6 dBu, die Übersteuerungsreserve beträgt 9 dB; der Spitzenpegel bei 0 dB_{FS} beträgt also 15 dBu (Werkseinstellung in kalibriertem Betrieb, UCAL leuchtet nicht). Wird ein anderer Headroom-Wert für kalibrierten Betrieb gewünscht, kann dies im Geräteinneren mit einem Trimpotentiometer pro Kanal eingestellt werden (Einstellbereich +4...+24 dBu bei 0 dB_{FS}; siehe 2.4).

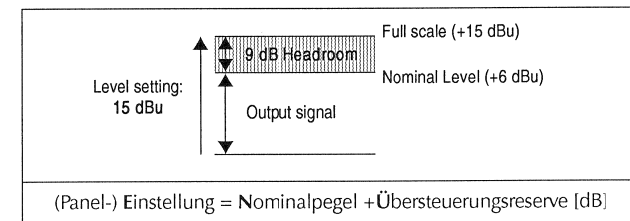

Hinweis: Für die MONITOR-Ausgänge LINE OUT und PHONES sind die Potentiometer «1» bis «8» immer aktiv – dadurch kann ein von den Hauptausgängen unabhängiger, zweikanaliger Monitor-Mix erstellt werden (siehe Funktion «MixMonitor»).

- [7] **MONITOR-Potentiometer** PegelEinstellung des Kopfhörer- und des LINE OUT-Ausgangs an der Frontplatte.

- [8] **LINE OUT** 5-poliger XLR-Einbaustecker; zweikanaliger, elektronisch symmetrierter Monitor-Ausgang für den Monitor-Mix. Einstellung des Summenpegels mit dem Potentiometer MONITOR [7].

- [9] **PHONES** 6,3-mm-Klinkenbuchse (AusgangsImpedanz 100 Ω), für Kopfhörer mit Impedanzen >200 Ω. Einstellung des Summenpegels mit dem Potentiometer MONITOR [7].
 Im Kopfhörer-Verstärker ist ein Binaural-Konverter integriert, der die Im-Kopf-Lokalisation eliminiert. Auch ausgedehnte Hörsitzungen sind dadurch weit weniger ermüdend.

2.2 Audio-Anschlüsse, Stiftbelegungen

2.2.1 AES/EBU, Digital-Eingang (XLR-3f)

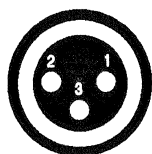

Pin	Bezeichnung
1	Masse
2	Eingang +
3	Eingang -
-	Chassis

2.2.2 LINE-Ausgänge (XLR-3m, transformator-symmetriert)

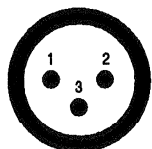

Pin	Bezeichnung
1	Masse
2	Ausgang +
3	Ausgang -
-	Chassis

2.2.3 MONITOR PHONES (TRS-Klinke, 6,3 mm)

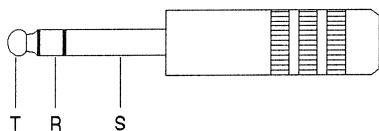

Pin	Bezeichnung
T (Tip)	Links
R (Ring)	Rechts
S (Sleeve)	Masse

2.2.4 MONITOR LINE OUT (XLR-5m, eletronisch symmetriert)

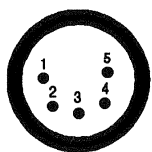

Pin	Bezeichnung
1	Masse
2	Ausgang + links
3	Ausgang - links
4	Ausgang + rechts
5	Ausgang - rechts
-	Chassis

2.2.5 Anwendung der 8-Kanal-TDIF-1-Schnittstelle

Das Tascam-Format TDIF-1 für digitale Ein- und Ausgänge kann zum Senden digitaler Audiodaten von DA-88- und kompatiblen Achtkanal-Geräten (oder auch vom D19 MicAD bzw. MicVALVE) zum D19 MultiDAC benützt werden.

Basis-Eigenschaften: 8-Kanal-Audiodaten mit Informationen über Abtastfrequenz und Emphasis, mit Sync-Signal.
Übertragungspegel C-MOS, asymmetrisch.

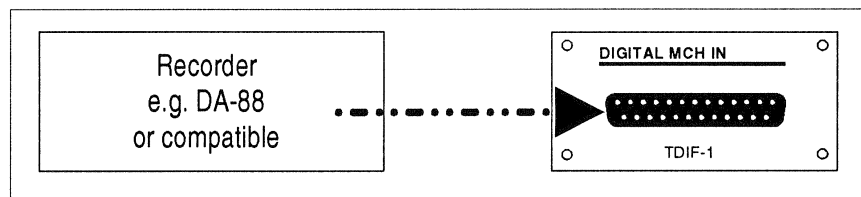

Kabel: Bestell-Nr.: F-10.025.031.08 (1,0 m)
F-10.025.031.09 (5,0 m)

Wichtig: Die Kabellänge sollte 10 m nicht überschreiten.
Es wird empfohlen, nur die angegebenen Verbindungskabel zu benutzen (Bestell-Nummern siehe oben).

Pinbelegung:

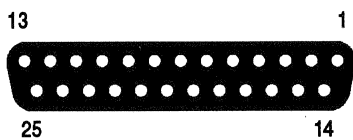

Pin	Bezeichnung
1	(DOUT 1/2)
2	(DOUT 3/4)
3	(DOUT 5/6)
4	(DOUT 7/8)
5	(LRCK OUT)
6	(FS 1 OUT)
7	GND
8	FS 1 IN
9	LRCK IN
10	DIN 7/8
11	DIN 5/6
12	DIN 3/4
13	DIN 1/2
14	GND
15	GND
16	GND
17	GND
18	(EMPHASIS OUT)
19	(FS 0 OUT)
20	FS 0 IN
21	EMPHASIS IN
22	GND
23	GND
24	GND
25	GND

Kabel-Konfiguration:

25-pol D-Typ, m	Aderfarben (verdrillte Paare)	25-pol D-Typ, m
1 14	org/red 1 org/blk 1	13 25
2 15	gry/red 1 gry/blk 1	12 24
3 16	wht/red 1 wht/blk 1	11 23
4 17	yel/red 1 yel/blk 1	10 22
5 9	pnk/red 1 pnk/blk 1	9 5
7 18	org/red 2 org/blk 2	7 21
6 19	gry/red 2 gry/blk 2	8 20
8 20	wht/red 2 wht/blk 2	6 19
21 Schirm + Gehäuse	yel/red 2 yel/blk 2	18 Schirm + Gehäuse
10 22	pnk/red 2 pnk/blk 2	4 17
11 23	org/red 3 org/blk 3	3 16
12 24	gry/red 3 gry/blk 3	2 15
13 25	wht/red 3 wht/blk 3	1 14

2.2.6 Anwendung der optischen 8-Kanal-ADAT-Schnittstelle

Das ADAT-Format ist ein serielles Achtkanal-Format und benützt ein einzelnes Faseroptik-Kabel.

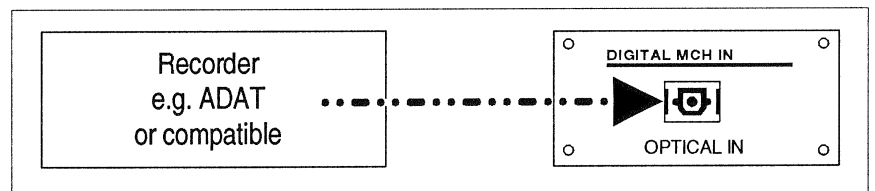

Steckertyp: TOCP 155 k
 Lichtleiterverbindung: TOFC 100

Die empfohlene Maximallänge der Verbindung gemäss Alesis-Spezifikation beträgt 1 m; in den meisten Fällen sind jedoch Verbindungen mit einer Länge von 10...15 m möglich.

3. SERVICE



Gefahr! Eingriffe im Inneren des Gerätes dürfen nur von geschulten Service-Technikern vorgenommen werden. Sicherungen dürfen nur durch solche des selben Typs ersetzt werden. Das Gerät darf vom Benutzer nicht geöffnet werden – *Risiko eines gefährlichen elektrischen Schlages!*



ESE-Bauteile Vorsicht: Die Bauteile sind empfindlich auf elektrostatische Aufladung. Beachten Sie die entsprechenden Hinweise am Anfang dieser Anleitung!

3.1 Benötigte Hilfsmittel

- Werkzeug:**
- Inbus-Schraubendreher Nr. 2,5 (im Lieferumfang)
 - Abgleich-Schraubendreher
 - ESE-Ausrüstung (leitfähige, geerdete Matte; Erdungs-Armband).
- Messgeräte:**
- Analog-Audio-Analyzer (z.B. in *Audio Precision «System One»* enthalten)
 - Digital-NF-Generator (z.B. in *Audio Precision «System One» Dual Domain* enthalten), oder
CD-Spieler mit AES/EBU-Digitalausgang und Test-CD

3.2 Einbau von Achtkanal-Schnittstellen

ADAT 8-Kanal-Eingangsmodul	1.660.050.20-V
TDIF 8-Kanal-Eingangsmodul	1.660.052.20-V
D19 LDP Receiver (long distance package)	1.660.059.20-V
<i>Pro Gerät kann nur eine dieser beiden Optionen verwendet werden.</i>	

- Vorgehen:**
- Gerät vom Netz trennen.
 - Gehäusedeckel abmontieren (6 IS-Schrauben – je 2 links und rechts, 2 oben).
 - Abdeckblech an der Rückwand abschrauben (2 IS-Schrauben).
 - Flachbandkabel (im Lieferumfang des Interfaces) durch die entstandene Öffnung in der Rückwand führen und auf dem Main Board (P28) einstecken.
 - Interface mit den beiden IS-Schrauben befestigen.
 - Gehäusedeckel montieren.

3.3 Jumpers

Vor dem Öffnen des Gerätes Netzstecker ziehen!

Zum Öffnen des Gerätes werden sechs IS-Schrauben Nr. 2,5 gelöst – je zwei links und rechts, zwei auf der Oberseite. Darauf kann der Gehäusedeckel abgehoben werden.

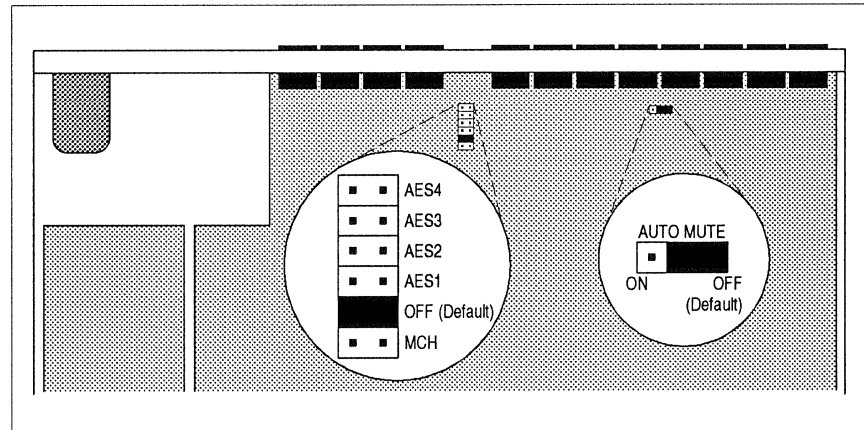

3.3.1 Auto Mute

Zusätzlich zur Standard-Stummschaltung können die eingesetzten D/A-Wandler eine interne Stummschaltung aktivieren. Dies bewirkt eine Verbesserung des Geräuschspannungs-Abstands um rund 3 dB auf Kosten eines geringfügigen Klickens, das jedoch in der Regel nur bei sehr hoher Abhörlautstärke wahrnehmbar wird.

Bedingungen für AUTO MUTE:

- Jumper ist in Stellung AUTO MUTE ON
- Der Digitaleingang erhält während mindestens ca. 8000 Samples die Information «digital Null».

Werkseinstellung: AUTO MUTE OFF.

3.3.2 Synchronisation

Für normale Anwendungen synchronisiert sich jeder Wandler selbstständig mit seinem Eingangssignal. Zur Vermeidung von Phasenproblemen in System-Installationen kann ein beliebiger der Eingänge als gemeinsame Synchronisations-Referenz bestimmt werden. Diese Wahl geschieht durch einen Jumper mit mehreren Positionen (siehe Grafik auf der vorhergehenden Seite).

AES1...4: Der betreffende AES/EBU-Eingang ist die Sync-Referenz.

OFF (Werkseinstellung): Jeder Wandler bezieht das Synchronisationssignal von seinem eigenen AES/EBU-Eingangssignal.

MCH: Der MCH-Eingang ist die Sync-Referenz.

3.4 Einstellungen

Vor dem Öffnen des Gerätes Netzstecker ziehen!

Zum Öffnen des Gerätes werden sechs IS-Schrauben Nr. 2,5 gelöst – je zwei links und rechts, zwei auf der Oberseite. Darauf kann der Gehäusedeckel abgehoben werden.

3.4.1 Ausgangspegel für kalibrierten Betrieb (CAL)

Werkseinstellung: 15 dBu für 0 dB_{FS}.

Der Ausgangspegel für kalibrierten Betrieb ist in den selben Grenzen einstellbar wie für unkalibrierten Betrieb (+4...+24 dBu für 0 dB_{FS}). Die Trimpotentiometer (RA9...16) für diese Einstellung sind direkt hinter den Potentiometern 1...8 [2] (RA17...24) im Inneren des Gerätes angeordnet.

Vorgehen:

- Digitalsignal mit bekanntem Pegel (z.B. Test-CD mit 0 dB_{FS}) an einem der Eingänge AES/EBU IN einspeisen.
- Kalibrierten Pegel wählen (UCAL-LED leuchtet nicht).
- Pegelmessgerät am entsprechenden Ausgang anschliessen.
- Mit entsprechendem Trimpotentiometer auf den gewünschten Pegel einstellen, Übersteuerungsreserve (Headroom) berücksichtigen (siehe auch 2.1).
- Einstellung für alle Kanäle wiederholen.

3.4.2 Subrange-Linearität

Vorgehen:

- Digitalsignal mit -20 dB_{FS} (z.B. von Test-CD) an einem der Eingänge AES/EBU IN einspeisen.
- Kalibrierten Pegel wählen (UCAL-LED leuchtet nicht).
- Pegelmessgerät am entsprechenden Ausgang anschliessen.
Mit dem entsprechenden Trimpotentiometer (RA1...RA8) auf einen Pegel einstellen, der 20 dB unter dem kalibrierten Pegel liegt (Einstellung: siehe 3.4.1). Falls der kalibrierte Pegel gemäss Werkseinstellung +15 dBu beträgt, muss der gemessene Pegel -5 dBu betragen.
- Einstellung für alle Kanäle wiederholen.

3.5 Ersatzteile

Betriebsanleitung d/e	10.27.4080
Drehknopf grau, mit Deckel grau, Ø 11 mm	42.01.1000
Einbau-Stecker, XLR 3-polig	54.02.0280
Einbau-Buchse, XLR 3-polig	54.02.0281
Einbau-Stecker, XLR 5-polig	54.21.2206
Einbau-Buchse, Klinke 6,3 mm, 3-polig	54.24.0103
Relais, 2 × U (DPDT), 5 V, 125 V/2 A, Ag/Au	56.04.0198
Potentiometer, 10 kΩ lin, ±10%	58.20.6101
Potentiometer, 2 × 10 kΩ lin, ±10%	58.20.6202
Netzteil 24 V, 40 W	89.20.2002
Zugentlastungs-Set	1.650.058.00
Display-Fenster	1.660.010.02
Main Board	1.660.030.20-V
Keyboard	1.660.040.00-V
ADAT 8-Kanal-Eingangsmodul	1.660.050.20-V
TDIF 8-Kanal-Eingangsmodul	1.660.052.20-V
D19 LDP Receiver-Modul	1.660.059.20-V
ADAT Opto-Kabel, 1 m	10.325.010.00
ADAT Opto-Kabel, 5 m	10.325.011.00
TDIF-Verbindungskabel PW-88D, 1 m	F-10.025.031.08
TDIF-Verbindungskabel PW-88D, 5 m	F-10.025.031.09
Zubehörsatz MultiDAC	20.020.302.52
bestehend aus:	
4 XLR-Stecker dreipolig	
8 XLR-Kupplungen dreipolig	
1 XLR-Kupplung fünfpolig	
2 Drehknöpfe	
je 4 Schrauben und Unterlegscheiben für Rackeinbau	

CONTENTS

1	Come in!	E1/1
1.1	Basic information	E1/1
1.2	General	E1/2
1.2.1	Scope of delivery	E1/2
1.2.2	Options.....	E1/2
1.2.3	Accessories	E1/2
1.3	Safety and connections	E1/3
1.3.1	Utilization for the purpose intended	E1/3
1.3.2	Power connection	E1/3
1.3.3	Connector field	E1/4
1.4	Technical specifications	E1/5
1.4.1	Audio data	E1/5
1.4.2	Power supply	E1/5
1.4.3	Primary fuse.....	E1/5
1.4.4	Operating conditions.....	E1/6
1.4.5	Safety and EMC standards.....	E1/6
1.4.6	Mechanical data.....	E1/6
2	Operation	E2/1
2.1	Operating elements	E2/1
2.2	Audio connections, pin assignments	E2/3
2.2.1	AES/EBU, digital input	E2/3
2.2.2	Line outputs	E2/3
2.2.3	MONITOR Phones	E2/3
2.2.4	MONITOR LINE OUT	E2/3
2.2.5	Using the 8-channel TDIF-1 interface.....	E2/4
2.2.6	Using the 8-channel ADAT interface	E2/5
3	Service	E3/1
3.1	Required tools.....	E3/1
3.2	Installing an optional 8-channel interface	E3/1
3.3	Jumpers.....	E3/2
3.3.1	Auto Mute.....	E3/2
3.3.2	Synchronisation	E3/2
3.4	Adjustments	E3/3
3.4.1	Output level for calibrated mode (CAL)	E3/3
3.4.2	Sub-range linearity	E3/3
3.5	Spare parts	E3/4
4	Diagrams	

"ADAT" is a trade mark of Alesis Corporation.

"TDIF-1" is a trade mark of Tascam Corporation.

I COME IN!

We are happy to welcome you in the steadily growing circle of the Studer D19 MultiDAC's users, and we felicitate you on your selection. Thanks to Studer's experience collected during more than 40 years of business in the professional audio products field, you may expect that the performance of your new unit will fulfill your highest demands.

I.1 Basic information

The Studer D19 MultiDAC contains eight D/A converters with 23 bit resolution. Rather than just having basic D/A functions, some enhancement features have been included. For this reason, a few simple and ergonomically laid out operating elements are found.

Eight potentiometers have a dual function – they serve as output level controls in the uncalibrated mode and/or as monitor level controls. In the calibrated position, the output level is set internally. LED indicators for signal quality (MUTE) and deemphasis flag (EMPH) are also included. A SEL button selects a channel to the central operating area.

MixMonitor: Next to high-quality conversion there is always the wish for suitable monitoring. The MixMonitor function allows front panel listening of any of the outputs in mono or stereo for easy and quick control of any of the channels. Any combination of the output channels can be mixed to the monitor output in mono or stereo for listening to up to 8 channels.

The MixMonitor controls are situated on the right side of the front panel and comprise a headphones jack, a 5-pin balanced line level XLR output and a volume control. With the MixMonitor function a variety of tasks can be performed, such as direct off-track monitor mixing when the unit is used in conjunction with a MDM recorder for direct-to-track recording. Obviously, any channel can also individually be selected to the Monitor output for checking or measurements. In the calibrated mode the line outputs have a fixed gain, and the channel potentiometers only influence the monitor mix. So the MultiDAC is not only a high-quality D/A converter, but also an 8-channel mixer.

Connections: To simplify system connection the MultiDAC is equipped with exactly the same audio interface types as the MicAD. The MultiDAC is delivered with four AES/EBU inputs as standard and there is a selection of ADAT or TDIF-1 multichannel input cards as options. This enables direct connection of the popular 8-channel Modular Digital Multitrack recorders. Any channel pair can be selected to take its signal either from the AES/EBU input or from the corresponding channel of the multichannel card. The eight analogue outputs are transformer balanced and have XLR connectors.

Synchronisation: The individual D/A converters can operate from a wide range of sampling frequencies. There is no need for an external sync signal because each D/A converter is equipped with an asynchronous sampling frequency converter synchronising to the incoming signals; i.e., each input can work with a different sampling rate if needed.

Should a fixed sync reference be required in order to avoid phase problems in system installations, the MultiDAC can be internally switched to use one of the inputs (any AES or MCH) as a reference for all D/A converters.

I.2 General

I.2.1 Scope of delivery

The D19 MultiDAC (Order No. 66.660.000.00) is shipped with an IEC 320/C13 socket, a hex-socket screwdriver (2.5 mm), and this operating manual.

I.2.2 Options

Order No.

Digital audio input options:

ADAT interface:	8-channel optical digital audio input card for connecting to ADAT and compatible 8-channel recorders or other equipment featuring the ADAT standard connectors.	1.660.050.20
TDIF-1 interface:	8-channel digital audio input card for connecting to DA-88 and compatible 8-channel recorders or other equipment featuring the TDIF-1 standard connectors.	1.660.052.20

I.2.3 Accessories

Order No.

Accessories/spares:	Kit, consisting of: <ul style="list-style-type: none"> • XLR connectors (4 pcs male, 8 pcs female, 1 pce 5-pin female) • Rotary knobs (2 pcs) • Rack mounting screws with washers (4 pcs each) 	20.020.302.52
Interface cables:	ADAT/Alesis, optical interface cable, length 1.0 m	10.325.010.00
	ADAT/Alesis, optical interface cable, length 5.0 m	10.325.011.00
	TDIF-1/Tascam interface cable "PW 88D", length 1.0 m	F-10.025.031.08
	TDIF-1/Tascam interface cable "PW 88D", length 5.0 m	F-10.025.031.09

1.3 Safety and connections

1.3.1 Utilization for the purpose intended



The Studer D19 MultiDAC is designed for professional use. It is presumed that the unit is operated only by trained personnel; servicing must be performed by qualified experts.

The electrical connections may be connected only to the appropriate voltages and signals specified in this manual. Please consult the Safety and EMC sections at the very beginning of this manual.

1.3.2 Power connection

There is no need to select a specific mains voltage setting because the unit can be operated on mains voltages from 100 through 240 V_{AC}, 50 to 60 Hz.

Important!



Repair work may only be performed by a trained service technician. The primary fuse inside the unit must be replaced by a spare fuse of exactly the same type.

The unit must not be opened by the user – risk of a severe electric shock hazard!

Power cable:



The supplied power socket has to be fitted with a mating power cable incl. plug by an electrician, if your local Studer agency or your dealer should not have added a fitting power cable.

- Please consult the Safety section at the very beginning of this manual!

I.3.3 Connector field

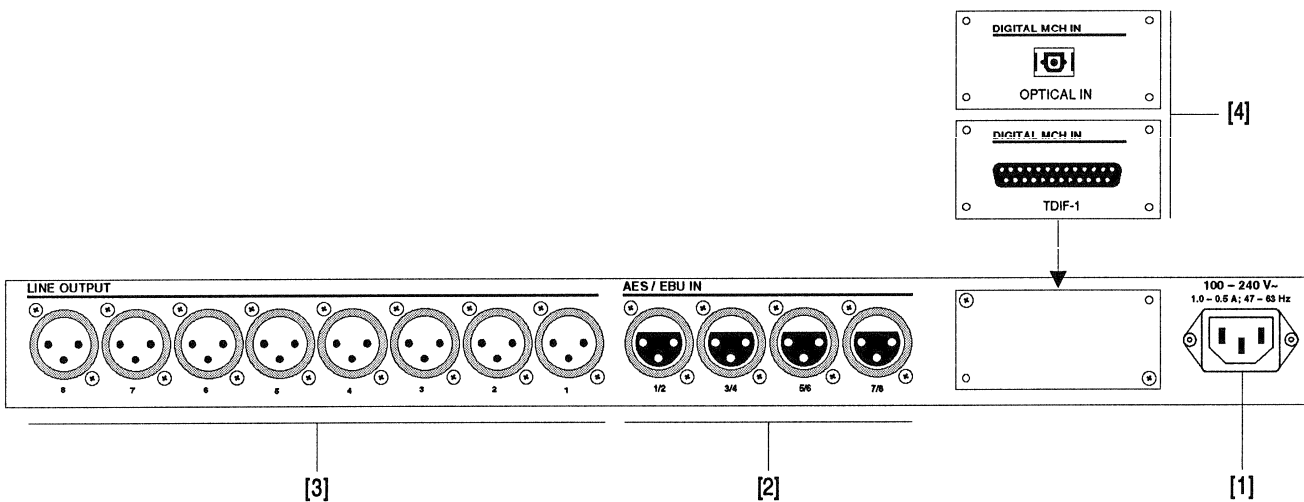

[1] 100 – 240 V

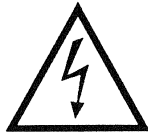

Connector for socket IEC 320/C13.

Supply voltage range 100...240 V_{AC} (without voltage selector);
mains frequency 50...60 Hz.

For connecting to the mains, please consult the Safety section at the very beginning of this manual.

[2] AES/EBU IN

Inputs for four digital input signals according to AES/EBU, with female XLR connectors.

[3] LINE OUTPUTS

Analogue line outputs with male XLR connectors. Output impedance $\leq 40 \Omega$, transformer-balanced.

[4] MCH IN

Optional, digital multichannel inputs; can be selected from TDIF-1 8-channel format or optical ADAT 8-channel format.

I.4 Technical specifications (preliminary, subject to change without notice)

I.4.1 Audio data (20 Hz...20 kHz, at +15 dBu_{fs} unless otherwise noted)

D/A conversion: Resolution 23 bit, linear.

LINE OUTPUT:

Frequency response: ± 0.1 dB
 S/N ratio: > 115 dB, unweighted, Auto Mute OFF, +24 dBu_{FS}
 > 119 dB, unweighted, Auto Mute ON, +24 dBu_{FS}
 THD+N: < -80 dB_{FS}, at 0 dB_{FS}
 < -110 dB_{FS} (typ. -112 dB_{FS}), at -30 dB_{FS}
 Crosstalk: < -95 dB (typ. -100 dB)
 < -110 dB, 1 kHz
 Output impedances: typ. <30 Ω
 max. <40 Ω
 Maximum output level: typ. 24 dBu (load 100 k Ω)
 typ. 23.5 dBu (load 600 Ω)

MONITOR OUTPUT:

Frequency response: ± 0.1 dB
 THD+N: < -80 dB_{FS}, at 0 dB_{FS}, 1 kHz
 < -110 dB_{FS} (typ. -112 dB_{FS}), at -30 dB_{FS}, 1 kHz
 Crosstalk: < -95 dB (typ. -100 dB)
 < -110 dB, 1 kHz
 Output impedances: <50 Ω (LINE OUT)
 100 Ω (PHONES)
 Maximum output level: typ. 24 dBu (load 100 k Ω)
 typ. 23.5 dBu (load 600 Ω)

I.4.2 Power supply

Mains voltage: 100...240 V_{AC}, 50...60 Hz
 Current consumption: 1...0.5 A
 Power inlet: IEC 320/C14

I.4.3 Primary fuse



Danger: *The primary fuse is located inside the unit. Repair work may only be performed by a trained service technician. The primary fuse must be replaced by a spare fuse of exactly the same type and value. The unit must not be opened by the user – risk of a severe electric shock hazard.*

Spare fuse: T 2.0 A H 250 V UL, CSA (5 × 20 mm) Order No. 51.01.1022

I.4.4 Operating conditions

Ambient temperature: +10°...+40°C
 Relative humidity: Class F (DIN 40040)

I.4.5 Safety and EMC standards

Safety: Protection class I according to EN 60950; 1992 + A1/A2; 1993 (UL 1950)
 EMC: Product family standard for audio, video, audio-visual, and entertainment lighting control apparatus for professional use.
 Emission: EN 50081-1; 1992
 Immunity: EN 50082-1; 1992

I.4.6 Mechanical data

Weight: approx. 5 kg
 Dimensions: [mm]

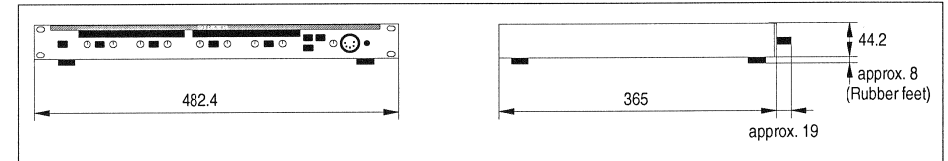

2 OPERATION

2.1 Operating elements

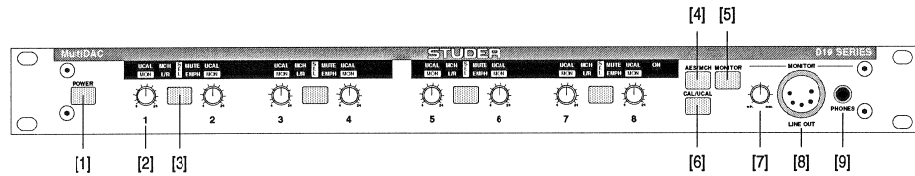

[1] POWER Recessed pushbutton to switch the unit on or off. During the initialization (i.e. some seconds after power-on) all SEL LEDs flash, the outputs are muted and the keys are disabled. When the unit is powered-on, at least the yellow ON LED at the far right of the right-hand display window is on. The unit is ready to operate with the factory default settings. The subsequent settings remain stored in a Flash EPROM after switching the unit off (unit contains no battery).

[2] Potentiometers 1...8 Multifunction potentiometers:
MixMonitor: Each of the channels can be selected and mixed – depending on the MONITOR [5] function status – either to one or both monitoring outputs. Setting range: 20 dB by means of potentiometer [2].
UCAL: In the UCAL position the potentiometers influence the level of the output with the same number (setting range +4...+24 dBu at 0 dB_{FS}) as well as the monitoring mix. Also refer to CAL/UCAL [6].

Headroom: The output level setting is given in dBu for full scale modulation; an input signal with 0 dB_{FS} causes peak level at the D/A converter's output. In order to keep the correct level ratio in a system with A/D converters and other studio equipment, a certain headroom must be selected.

Example: Nominal studio level +6 dBu, the desired headroom is 12 dB; the *peak level* at 0 dB_{FS} amounts to +18 dBu; adjustment in uncalibrated mode (UCAL is on) with potentiometer [2]. Also refer to CAL/UCAL [6].

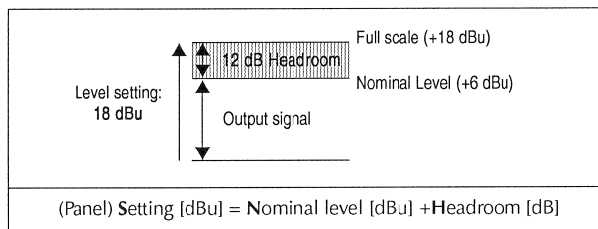

[3] SEL Keys for assigning the global function keys (AES/MCH [4], MONITOR [5], CAL/UCAL [6]) to the channel pairs. Press the SEL key of the desired channel (or press and hold one of the SEL keys and press the SEL key of any other desired channel); the corresponding yellow SEL LEDs are on. The AES/MCH, MONITOR, and CAL/UCAL function keys now can be operated. Pressing a SEL key a second time will cancel the assignment and the LED.

[4] AES/MCH Switchover of the channel pair preselected with SEL [3] from AES/EBU input to the corresponding channel pair of the MCH input (MCH LED is on); if no MCH interface is installed or if no input signal is available the red MUTE LED is on.

[5] MONITOR Monitoring mode selection of both LINE OUT and PHONES outputs. If a channel pair has been preselected with SEL, the MONITOR key successively toggles between the following five statuses:

1. L → MON. L
R → MON. R
Monitoring the left channel only (e.g. CH1) on both monitoring channels (the green MON LED of CH1 is on);
2. L → MON. L
R → MON. R
Monitoring the right channel only (e.g. CH2) on both monitoring channels (the green MON LED of CH2 is on);
3. L → MON. L
R → MON. R
Monitoring the left and the right channel added to a mono signal on both monitoring channels (the green MON LEDs of CH1 and CH2 are on);
4. L → MON. L
R → MON. R
Two-channel monitoring of the left and the right channels (the green L/R LED and the green MON LEDs of CH1 and CH2 are on);
5. L → MON. L
R → MON. R
No monitoring (both MON LEDs are dark).

[6] CAL/UCAL The potentiometers "1" to "8" for level setting of the individual channels can be activated with UCAL (yellow UCAL LEDs are on); setting range +4...+24 dBu at 0 dB_{FS}. If they are not activated, the output level of the outputs (except the LINE OUT and PHONES monitoring outputs) is fixed at the calibrated level.

Example: Nominal studio level +6 dBu, the desired headroom is 9 dB; the *peak level* at 0 dB_{FS} amounts to 15 dBu (factory setting in calibrated mode, UCAL LED is off). If for calibrated mode an other headroom value should be required, this can be adjusted inside the unit with a trimmer potentiometer per channel (setting range: +4...+24 dBu at 0 dB_{FS}; refer to 2.4).

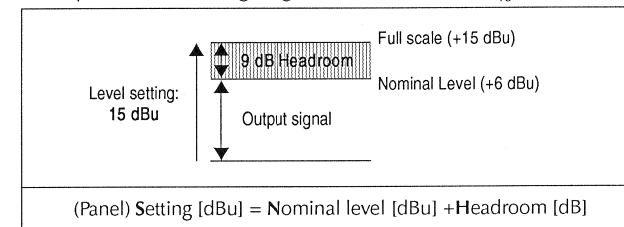

Note: For the MONITOR outputs LINE OUT and PHONES the potentiometers "1" to "8" are always active; in this way, a two-channel monitoring mix can be prepared which is independent of the main line outputs (refer to function "MixMonitor").

- [7] **MONITOR knob** Level setting of the PHONES and the LINE OUT outputs located on the front panel.

- [8] **LINE OUT** 5-pin male XLR connector; two-channel monitor output for the monitoring mix, electronically balanced. Setting of the monitoring level with the MONITOR [7] knob.

- [9] **PHONES** 6.3 mm jack socket (output impedance 100 Ω), for headphones with impedances >200 Ω. Setting of the monitoring level with the MONITOR [7] knob.
 The headphones amplifier is equipped with a binaural converter which minimizes in-head localization. Even extended listening sessions will be far less tiring thanks to this feature.

2.2 Audio connections, pin assignments

2.2.1 AES/EBU, digital input (XLR-3f)

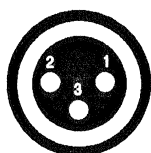

Pin	Description
1	Ground
2	Input +
3	Input -
-	Chassis

2.2.2 LINE outputs (XLR-3m, transformer-balanced)

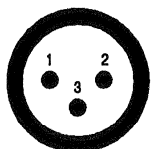

Pin	Description
1	Ground
2	Output +
3	Output -
-	Chassis

2.2.3 MONITOR PHONES (TRS plug, 6.3 mm)

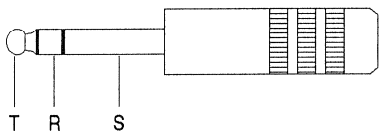

Pin	Description
T (Tip)	Left
R (Ring)	Right
S (Sleeve)	Ground

2.2.4 MONITOR LINE OUT (XLR-5m, electronically balanced)

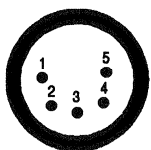

Pin	Description
1	Ground
2	Output + left
3	Output - left
4	Output + right
5	Output - right
-	Chassis

2.2.5 Using the 8-channel TDIF-I interface

The Tascam TDIF-1 digital I/O format is used for sending digital audio data from DA-88 and compatible eight-channel units (or from a D19 MicAD) to the D19 MultiDAC.

Basic characteristics: 8-channel audio data with sampling frequency information, emphasis information, and sync signal.
Signal transmission level is C-MOS, unbalanced.

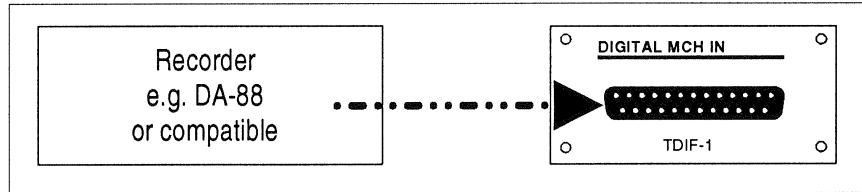

Cables: Order No.: F-10.025.031.08 (1.0 m)
F-10.025.031.09 (5.0 m)

Important: The maximum cable length should not exceed 10 m.
Only the specified connecting cables should be used (order numbers above).

Pin assignment:

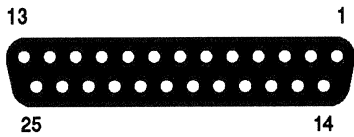

Pin	Designation
1	(DOUT 1/2)
2	(DOUT 3/4)
3	(DOUT 5/6)
4	(DOUT 7/8)
5	(LRCK OUT)
6	(FS 1 OUT)
7	GND
8	FS 1 IN
9	LRCK IN
10	DIN 7/8
11	DIN 5/6
12	DIN 3/4
13	DIN 1/2
14	GND
15	GND
16	GND
17	GND
18	(EMPHASIS OUT)
19	(FS 0 OUT)
20	FS 0 IN
21	EMPHASIS IN
22	GND
23	GND
24	GND
25	GND

Cable configuration:

25-pin D-Type, male	Cable colours (twisted pairs)	25-pin D-Type, male
1 14	org/red 1 org/blk 1	13 25
2 15	gry/red 1 gry/blk 1	12 24
3 16	wht/red 1 wht/blk 1	11 23
4 17	yel/red 1 yel/blk 1	10 22
5 9	pnk/red 1 pnk/blk 1	9 5
7 18	org/red 2 org/blk 2	7 21
6 19	gry/red 2 gry/blk 2	8 20
8 20	wht/red 2 wht/blk 2	6 19
21 Shield + housing	yel/red 2 yel/blk 2	18 Shield + housing
10 22	pnk/red 2 pnk/blk 2	4 17
11 23	org/red 3 org/blk 3	3 16
12 24	gry/red 3 gry/blk 3	2 15
13 25	wht/red 3 wht/blk 3	1 14

2.2.6 Using the optical 8-channel ADAT interface

The ADAT format is a serial 8-channel format. It uses a single fibre optic cable.

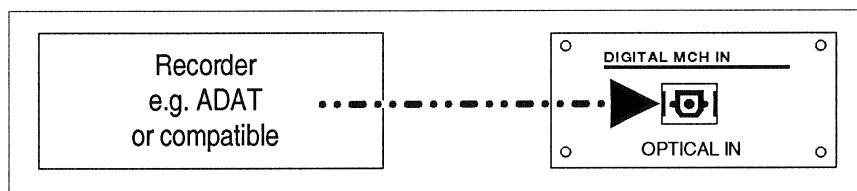

Plug type: TOCP 155 k
Optical fibre: TOFC 100

The maximum cable length specified by Alesis is 1 m. However, in most cases, operation with a cable length up to 10...15 m is possible.

3 SERVICE



Danger: Repair work may only be performed by a trained service technician. The primary fuse of the D19 MicVALVE must be replaced by a spare fuse of exactly the same type. The D19 MicVALVE must not be opened by the user – *risk of a severe electric shock hazard!*



ESD components Caution: Observe the precautions for handling electrostatically sensitive devices given at the beginning of this manual.

3.1 Required tools

Tools:

- Hex-socket-head screwdriver No. 2.5 (included)
- Small insulated screwdriver for adjusting trimmer potentiometers
- ESD equipment (conductive grounded mat, grounded wrist strap).

Test equipment:

- Analog audio analyzer (contained, e.g., in *Audio Precision "System One"*)
- Digital AF generator with balanced output (contained, e.g., in *Audio Precision "System One", Dual Domain version*), or CD player with Test CD

3.2 Installing an optional 8-channel interface

ADAT 8-channel input module	1.660.050.20-V
TDIF 8-channel input module	1.660.052.20-V
D19 LDP receiver module (long distance package)	1.660.059.20-V

Only one of the above interfaces can be installed per unit.

Procedure:

- Disconnect the unit from the mains.
- Remove upper cover (6 hex socket-head screws – 2 each on the left and the right-hand sides, 2 on the top).
- Remove the cover at the rear panel (2 hex socket-head screws).
- Insert the ribbon cable delivered with the interface through the hole in the rear panel and connect it to the Main Board (P28).
- Fasten the interface with the two hex socket-head screws.
- Re-install the top cover.

3.3 Jumpers

Before opening the unit make sure it is completely separated from the mains!

For opening, loosen six hex-socket-head screws Nr. 2.5 – two each at the left-hand and right-hand sides, two on the top. Afterwards the upper cover can be lifted off.

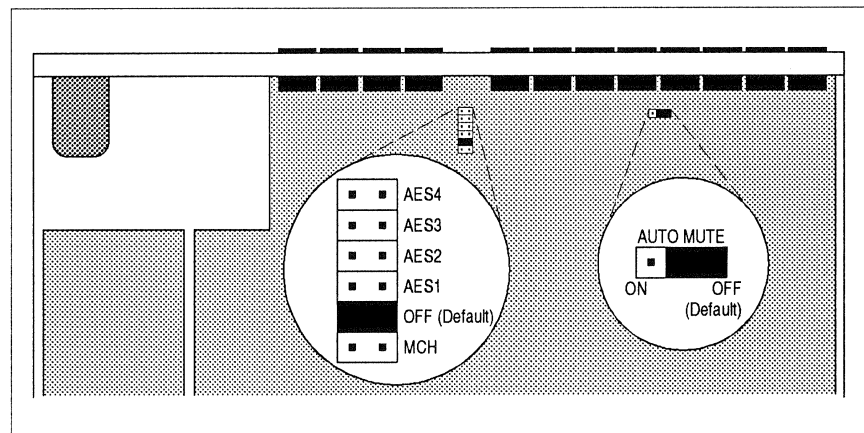

3.3.1 Auto Mute

In addition to the normal muting circuitry the converter chips can activate an internal muting. This results in an improvement of the S/N ratio by about 3 dB, at the cost of a minute click when activating the muting which usually can be perceived only at very high listening levels.

Conditions for AUTO MUTE:

- Jumper in position AUTO MUTE ON,
- The digital input signal remains at "digital zero" for at least about 8000 samples.

Factory default setting: AUTO MUTE OFF.

3.3.2 Synchronisation

For standard application each of the converters automatically synchronises to its own input signal. In order to avoid phase problems in system installations, any of the inputs can be selected as a sync reference for all converters. This selection is done with a multi-position jumper (refer to drawing on preceding page).

- AES1...4:** The corresponding AES/EBU input is used as sync reference.
OFF (factory default setting): Each converter is synchronised to its own AES/EBU input signal.
MCH: The MCH input is used as sync reference.

3.4 Adjustments

Before opening the unit make sure it is completely separated from the mains!

For opening, loosen six hex-socket-head screws Nr. 2.5 – two each at the left-hand and right-hand sides, two on the top. Afterwards the upper cover can be lifted off.

3.4.1 Output level for calibrated mode (CAL)

Factory default setting: 15 dBu for 0 dB_{FS}.
The output level for calibrated mode is adjustable within the same limits as for uncalibrated mode (+4...+24 dBu for 0 dB_{FS}). The trimmer potentiometers (RA9...16) for this setting are located inside the unit directly behind the potentiometers 1...8 [2] (RA17...24).

- Procedure:**
- Feed in a digital audio signal with known level (e.g. 0 dB_{FS} from a test CD) to one of the inputs AES/EBU IN.
 - Select calibrated level (UCAL LED is dark).
 - Connect a level meter to the corresponding line output.
 - Adjust with the corresponding trimmer potentiometer to the desired level, considering the required headroom (also refer to 2.1).
 - Repeat this adjustment for all channels.

3.4.2 Sub-range linearity

- Procedure:**
- Feed a digital signal with –20 dB_{FS} (e.g. from a test CD) into one of the AES/EBU IN inputs.
 - Select calibrated level (UCAL LED is dark).
 - Connect a level meter to the corresponding line output.
Adjust with the corresponding trimmer potentiometer (RA1...RA8) to a level 20 dB below calibrated level (adjusting the calibrated level: refer to 3.4.1). If the calibrated level is +15 dBu according to the factory setting, the measured level should be –5 dBu.
 - Repeat this adjustment for all channels.

3.5 Spare parts

Operating Instructions German/English	10.27.3860
Rotary knob grey, with cap grey, Ø 11 mm	42.01.1000
Connector, XLR-3-m	54.02.0280
Connector, XLR-3-f	54.02.0281
Connector, XLR-5-f	54.21.2206
TRS jack socket, 6.3 mm	54.24.0103
Relay, DPDT, 5 V, 125 V/2 A, Ag/Au	56.04.0198
Potentiometer, 10 kΩ lin, ±10%	58.20.6101
Potentiometer, 2 × 10 kΩ lin, ±10%	58.20.6202
Power supply 24 V, 40 W	89.20.2002
Strain relief kit	1.650.058.00
Display window	1.660.010.02
Main Board	1.660.030.20-V
Keyboard	1.660.040.00-V
ADAT 8-channel input module	1.660.050.20-V
TDIF 8-channel input module	1.660.052.20-V
D19 LDP receiver module	1.660.059.20-V
ADAT optical cable, 1 m	10.325.010.00
ADAT optical cable, 5 m	10.325.011.00
TDIF interface cable PW-88D, 1 m	F-10.025.031.08
TDIF interface cable PW-88D, 5 m	F-10.025.031.09
MultiDAC accessories kit	20.020.302.51
consisting of:	
4 XLR-3 plugs, male	
8 XLR-3 plugs, female	
1 XLR-5 plug, female	
2 rotary knobs	
4 rack mounting screws and washers	

SCHEMATA / CIRCUIT DIAGRAMS

Synopsis Main Board	1	
Block Diagram Audio	2	
Block Diagram Synchronization	2	
Main Board	1.660.030.22	3
Keyboard	1.660.040.00	23
ADAT Input Module	1.660.050.20	
LDP Receiver Module	1.660.059.20	25
TDIF-I Input Module.....	1.660.052.21	27

ABBREVIATIONS

COMPONENTS

B	bulb	LC	LC Display
BA	battery, accumulator	LS	loudspeaker
BR	optocoupler B->LDR	M	motor
C	capacitor	ME	meter
D	diode, DIAC	MIC	microphone
DL	LED light-emit. diode	MP	mechanical part
DLQ	optocoupler LED->QP	P	plug (male)
DLR	optocoupler LED->DLR	PU	pick up
DLZ	LED array, 7s.display	Q	transistor
DP	photodiode	QP	phototransistor
DZ	rectifier	R	resistor
EF	headphones	RP	photosensitive resist.
F	fuse	RT	temp. sensit. resist.
FL	filter	RZ	resistor array
H	head (sound-/erase-)	S	switch
HC	hybrid circuit	T	transformer
HE	hall element	TL	delay line
IC	integrated circuit	TP	test point
J	jack (female)	W	wire, stranded wire
JS	jumper	X	socket, holder
K	relay, contactor	XB	lamp socket
L	coil, inductance	XF	fuse holder
LC	LC Display	XIC	IC socket
LS	loudspeaker	Y	quartz, piezo element
L	coil, inductance	Z	network, array

SPECIFICATIONS OF ELEMENTS

CC	Carbon film	PCF	Carbon film
Cer	Ceramic	Petp	Polyester
Cerm	Cermet	Pme	Metallised polyester
EI	Electrolytic	PP	Polypropylen
Mf	Metal film	Si	Silicon
MP	Metal paper	Tri	Trimmer

MANUFACTURER OF COMPONENTS

ADI	Analog Devices Inc.	RCA	Radio Corporation
AMP	Ampex	---	RIVA
Com	Componex	SDS	
Dam	Dam Electronic	Sie	Siemens
Del	Delevan	SIG	Signetics
Ex	Exar	---	Stetner
GI	General Instruments	---	Stocko
Ha	Harris	St	Studer
Hi	Hirschmann	Sx	Siliconix
ITT	Intermetall, Valvo	Ti	Texas Instruments
Mot	Motorola	TDK	TDK
NEC	Nippon Electr. Corp.	---	Toko
NS	Nat. Semiconductors	To	Toshiba
Ph	Philips	Vi	Videlec
Ra	Raytheon		

POWERS OF TEN

Milli-	Micro-	Nano-	Pico-	Femto-	Tera-	Giga-	Mega-	Kilo-
10^{-3}	10^{-6}	10^{-9}	10^{-12}	10^{-15}	10^{12}	10^9	10^6	10^3
m	μ	n	p	f	T	G	M	k

CODE LETTERS AND COLORS

RESISTORS

COLOR	DIG	x	±	TC
gold	-	0,01	5%	-
silver	-	0,1	10%	-
black	0	1	-	-
brown	1	10	1%	$100 \cdot 10^{-6} / K$
red	2	100	2%	$50 \cdot 10^{-6} / K \#$
orange	3	1k	-	$15 \cdot 10^{-6} / K$
yellow	4	10k	-	$25 \cdot 10^{-6} / K$
green	5	100k	0,5%	-
blue	6	1M	0,25%	-
violet	7	10M	0,1%	-
grey	8	-	-	-
white	9	-	-	-

either no mark for TC, or red.
1 black ring only: 0 Ω = bridge)

CAPACITORS

The tolerance category is sometimes specified by a letter after the rated capacitance.

■ SERIES E6/E12/E24

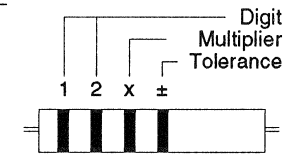

■ SERIES E48

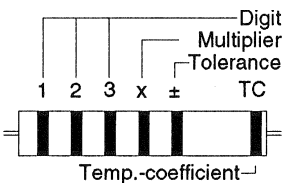

D = 0,5%	J = 5%
F = 1%	K = 10%
G = 2%	M = 20%

MOLDED RF COILS

A wide silver-colored ring and 4 thin, differently colored rings identify molded RF coils. The wide silver ring indicates the start of the counting direction. The second, third, and fourth ring indicate the inductance in micro Henry (μH), where two of the three rings represent the numeric value, the third one either a multiplier or the decimal point. In the latter case it has a golden color. The fifth ring identifies the tolerance in percent (\pm).

COLOR	DIG	x	±
black	0	1	-
brown	1	10	1%
red	2	100	2%
orange	3	10^3	-
yellow	4	10^4	-
green	5	10^5	0.5%
blue	6	10^6	-
violet	7	10^7	-
grey	8	10^8	-
white	9	10^9	-
gold	-	-	5%
silver	-	-	10%
any	-	-	20%

Examples:

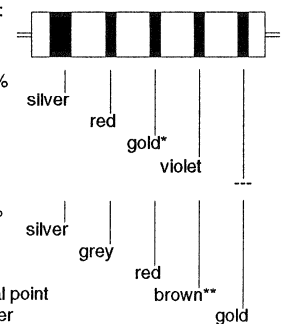

* Decimal point
** Multiplier

NOTE:

Some of the order numbers contained in the following lists are used for production purposes only. The reference numbers may deviate for service purposes.
Electrical components such as resistors, capacitors, transistors, IC's etc. having no special unit-specific number and not being identified respectively should be purchased locally.

Synopsis Main Board

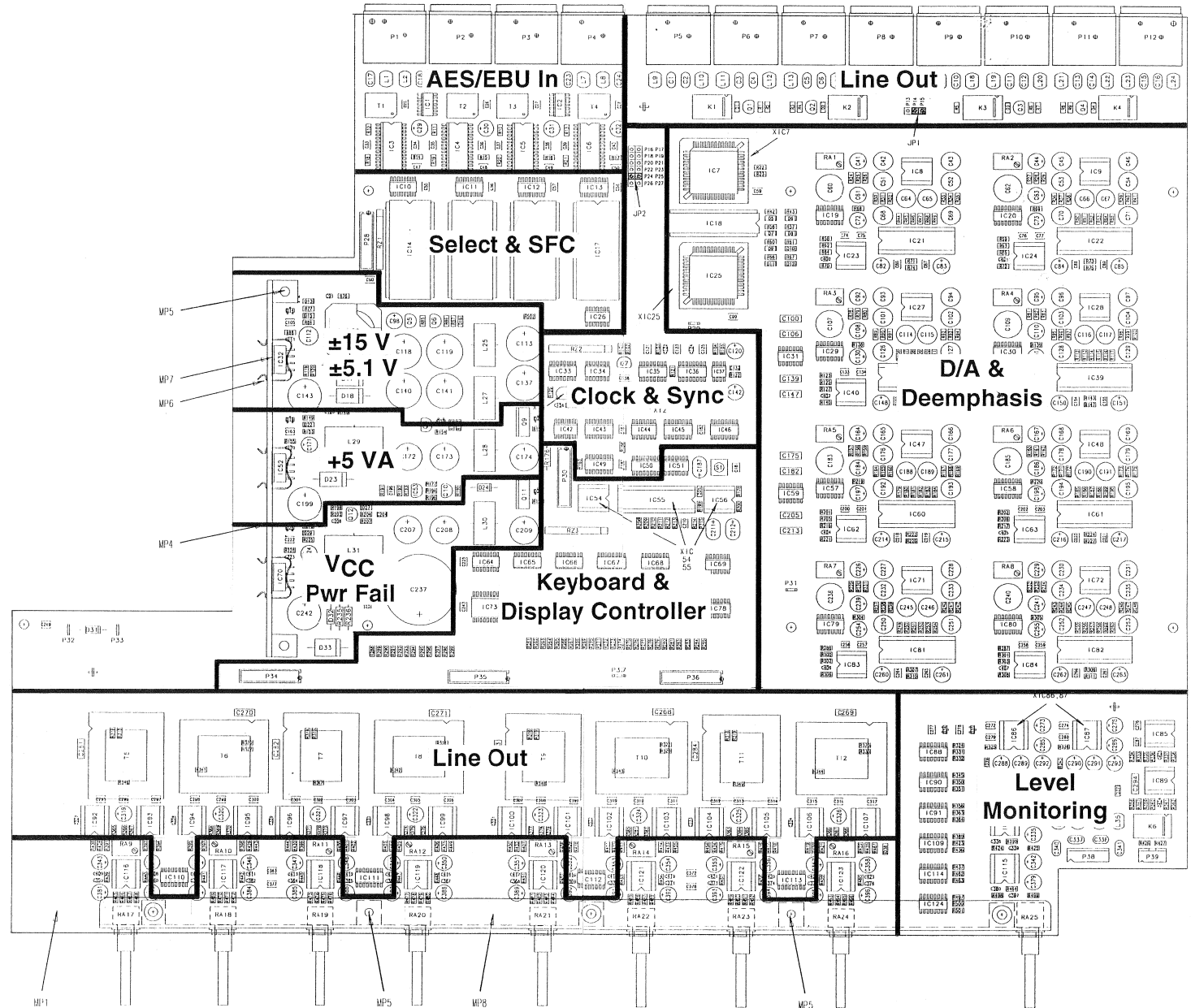

Block Diagram Audio

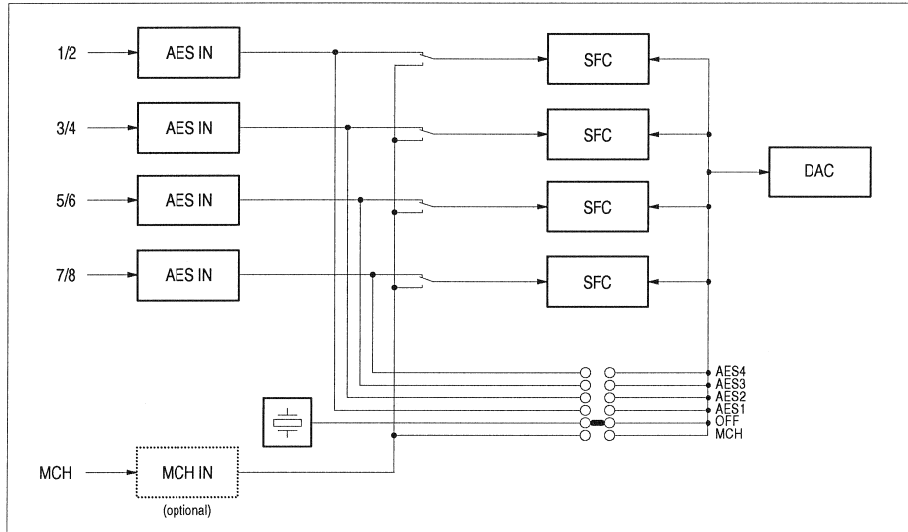

Block Diagram Synchronization

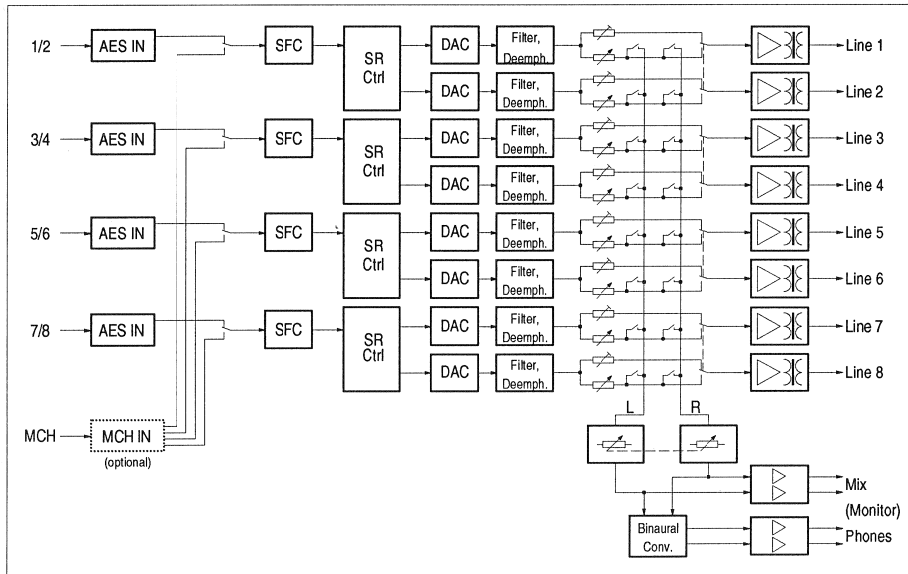



Main Board I.660.030.22

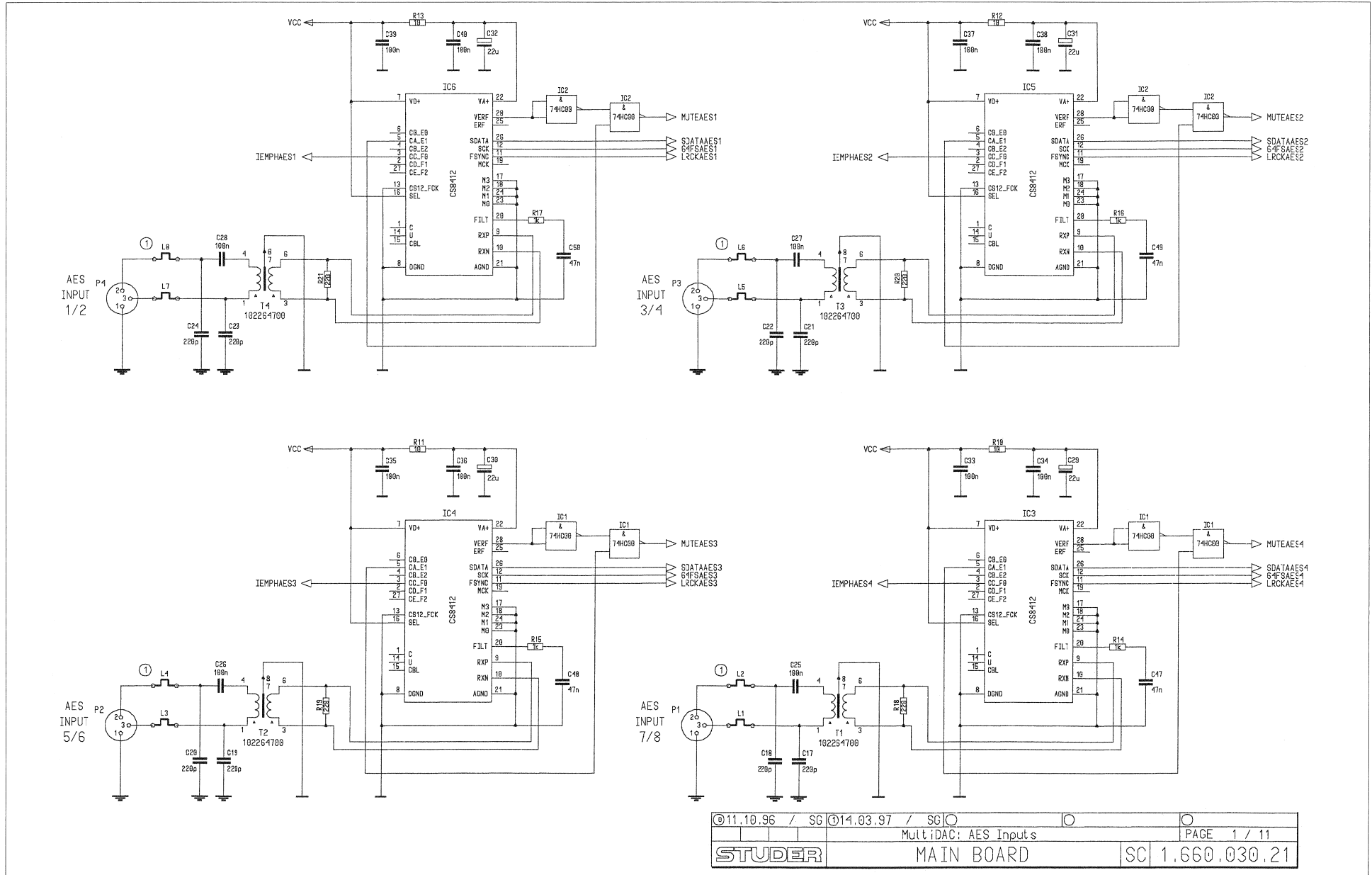

©11.10.96 / SG	©14.03.97 / SG	MultiDAC: AES Inputs	PAGE 1 / 11
STUDER		MAIN BOARD	SC 1.660.030.21



Main Board 1.660.030.22

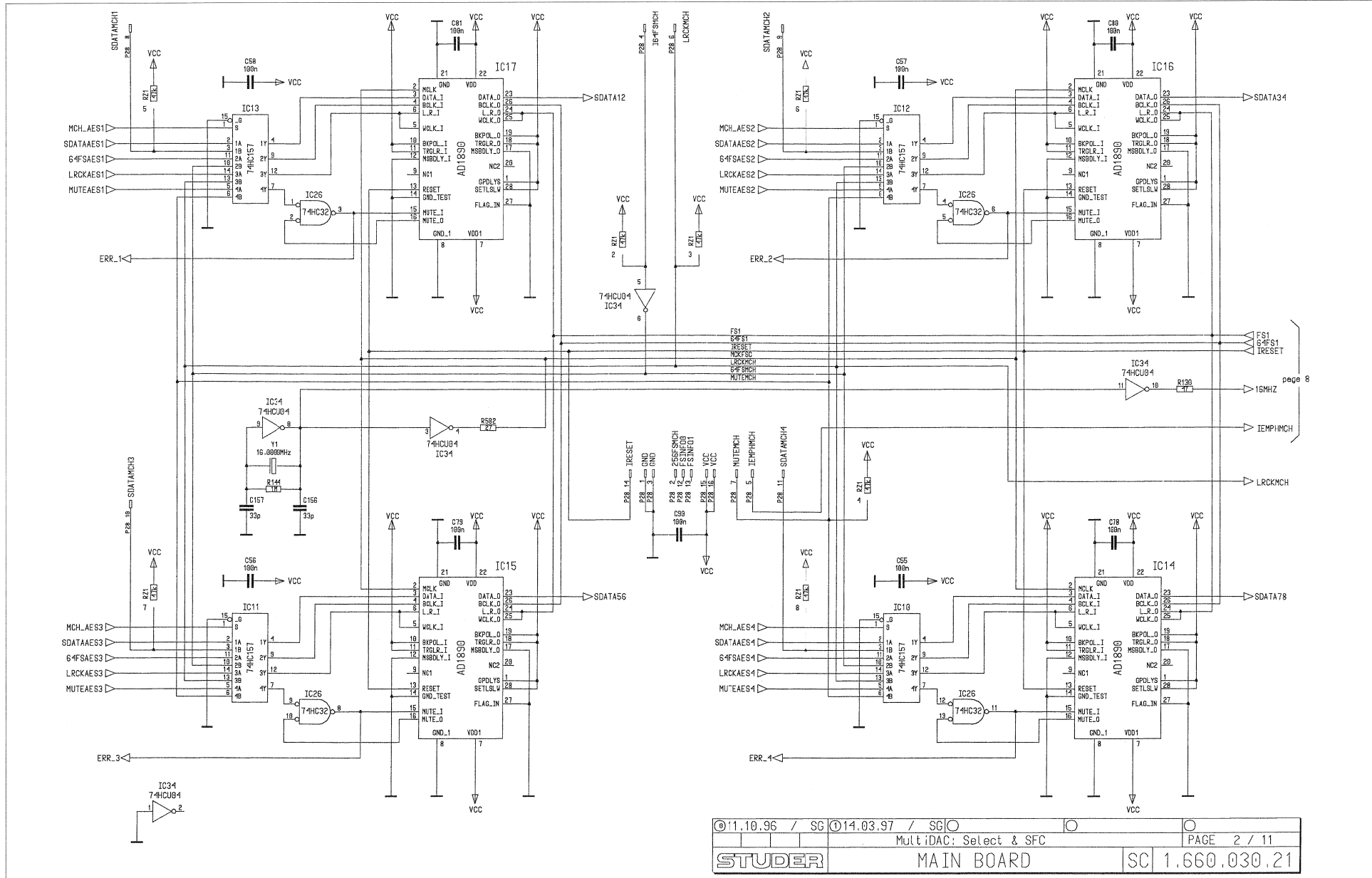



Main Board 1.660.030.22

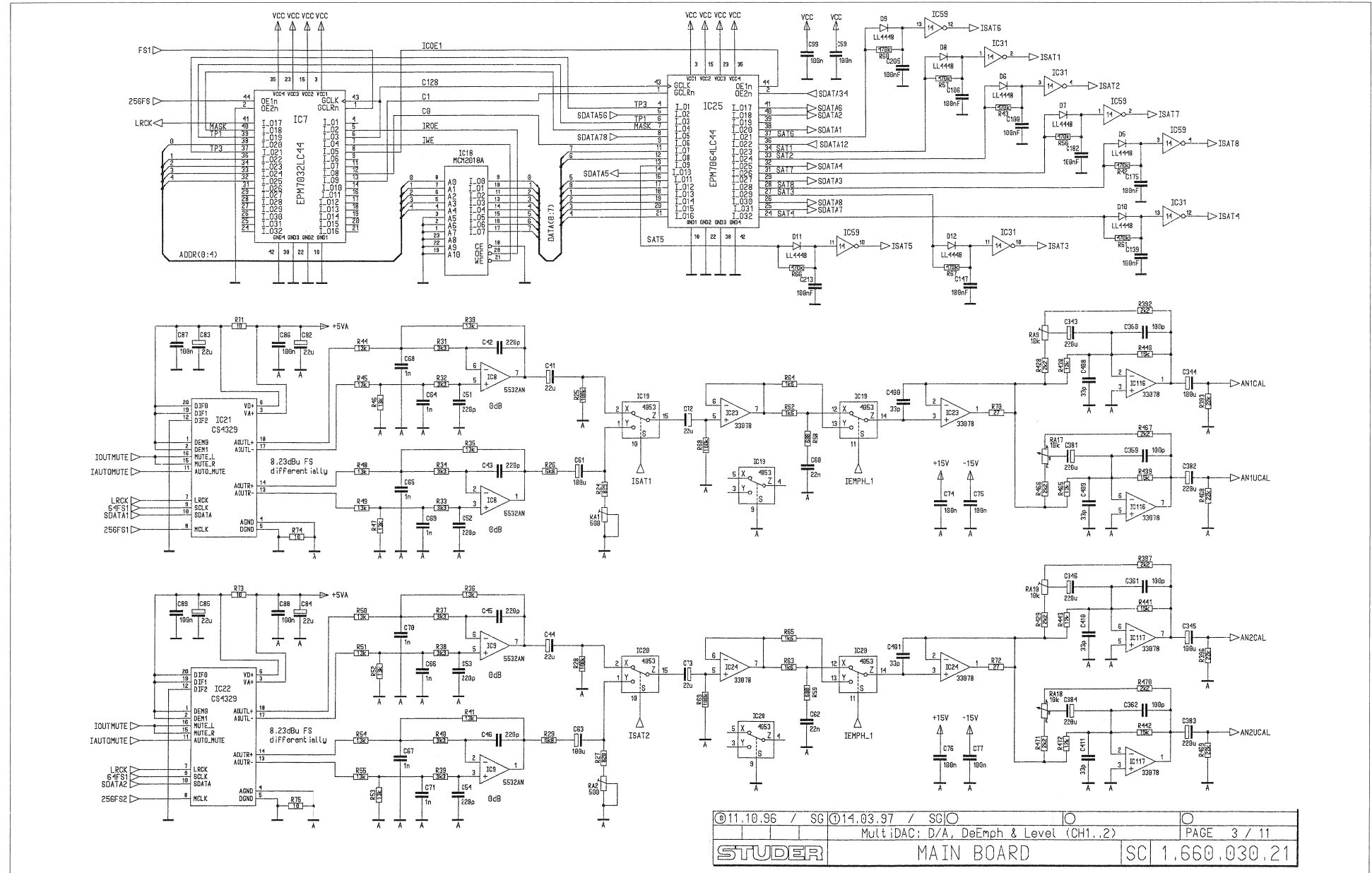

©11.10.96 / SG	©14.03.97 / SG	MultiDAC: D/A, DeEmph & Level (CH1..2)	PAGE 3 / 11
STUDER		MAIN BOARD	SC 1.660.030.21



Main Board 1.660.030.22

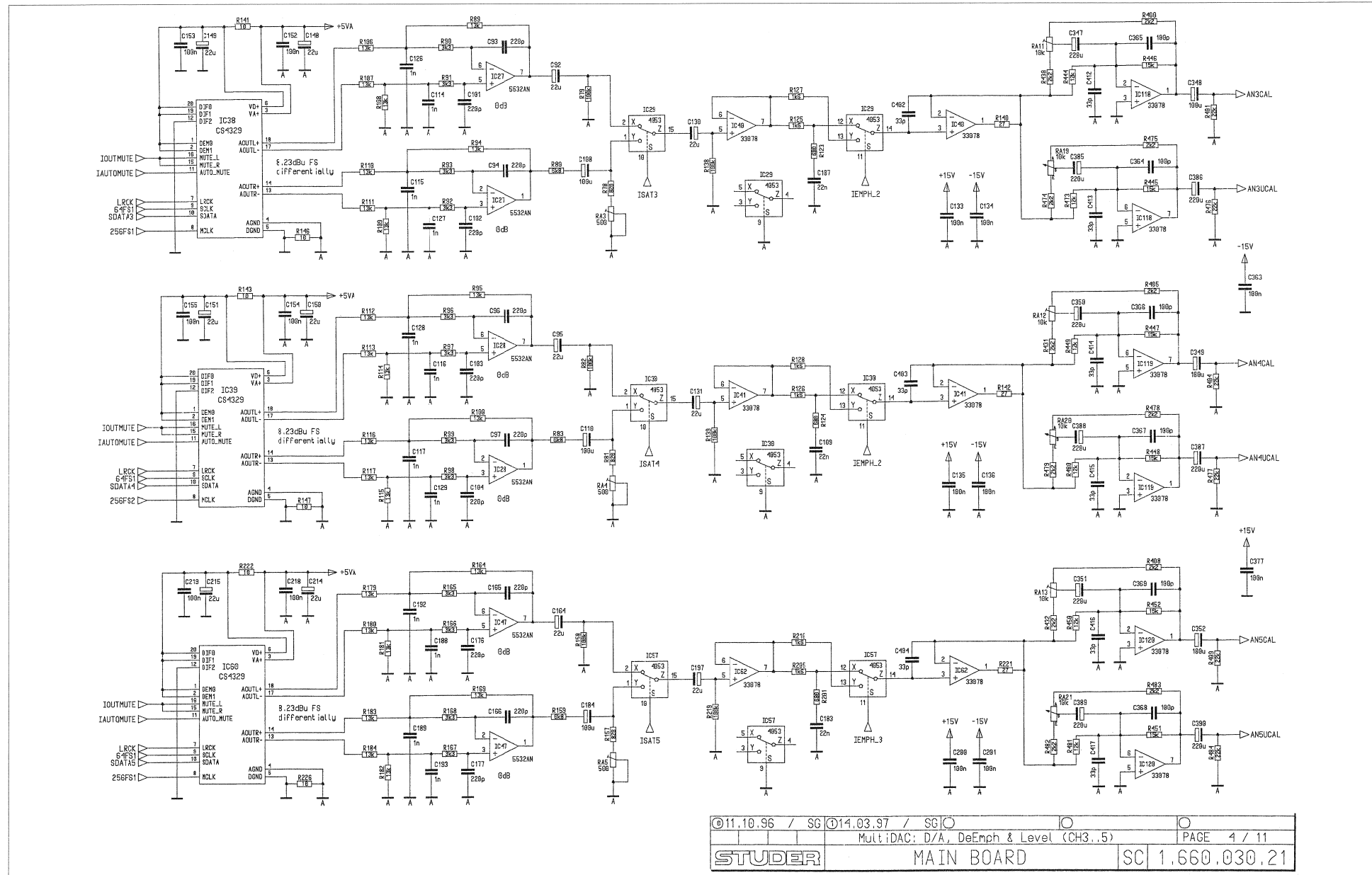

Main Board 1.660.030.22

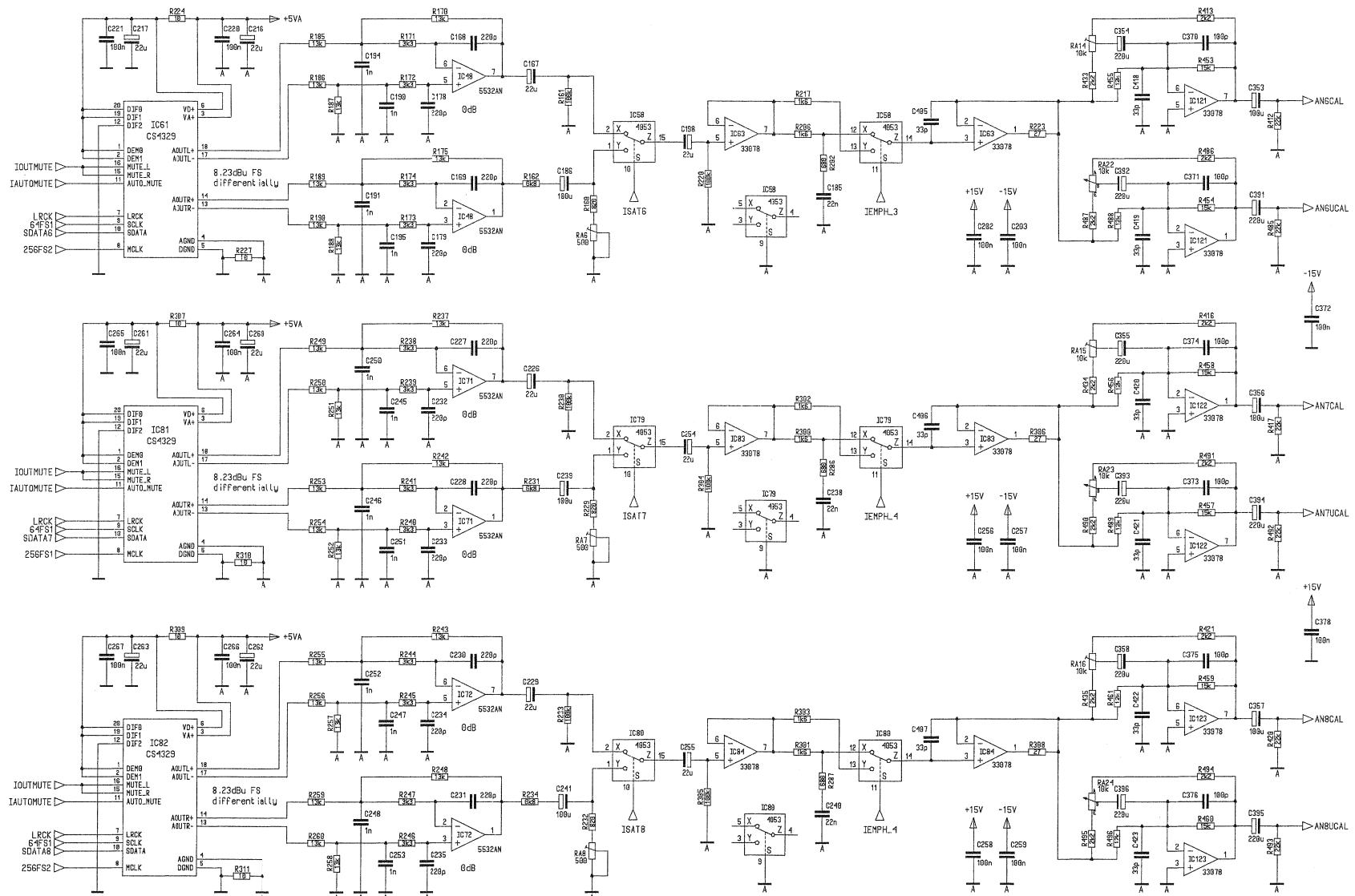

©11.10.96 / SG	©14.03.97 / SG	MultiDAC: D/A, DeEmph & Level (CH6..8)	PAGE 5 / 11
STUDER		MAIN BOARD	SC 1.660.030.21



Main Board 1.660.030.22

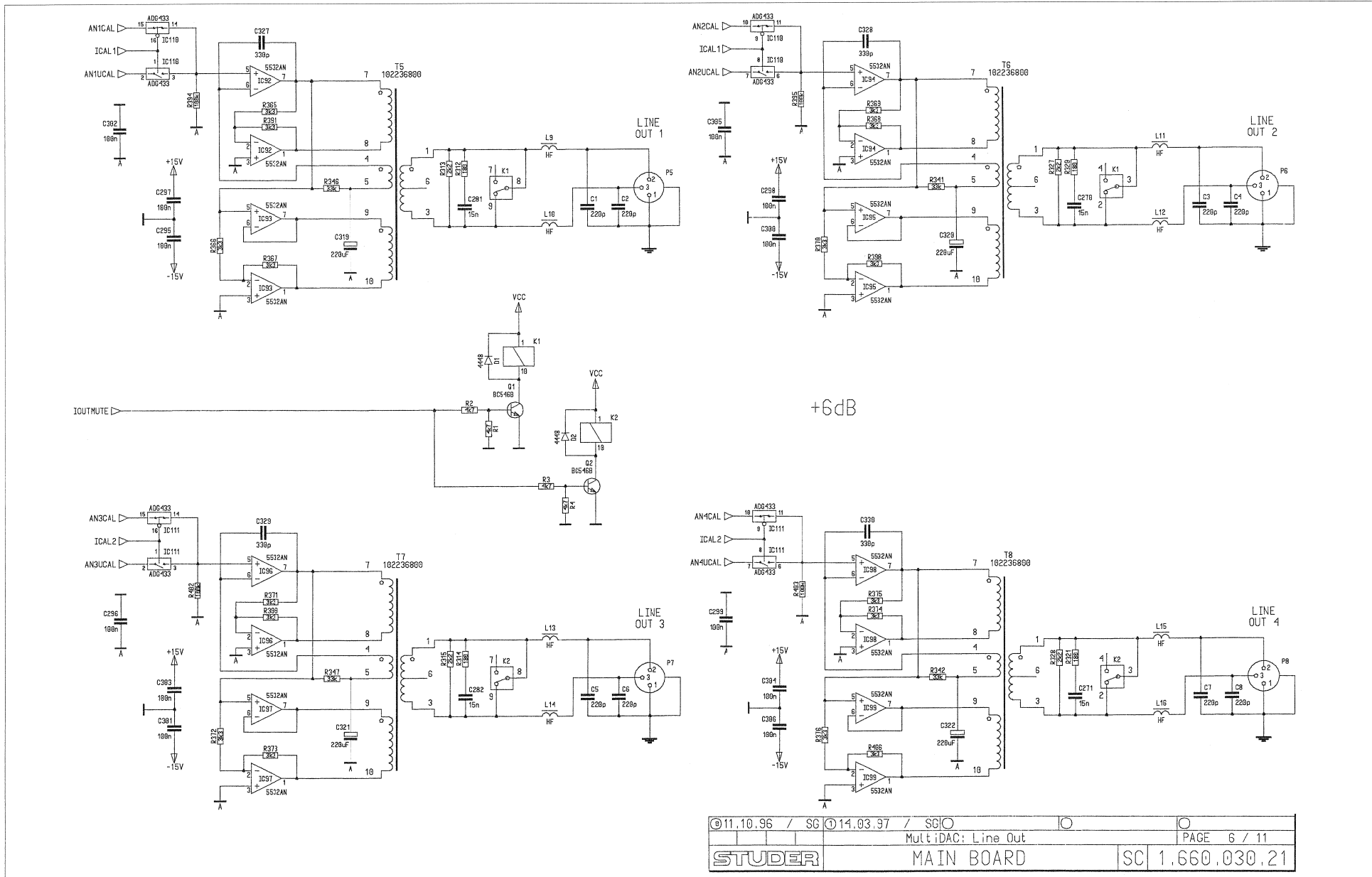

©11.10.96 / SG	©14.03.97 / SG		
MultiDAC: Line Out		PAGE 6 / 11	
STUDER		MAIN BOARD	
		SC	1.660.030.21



Main Board 1.660.030.22

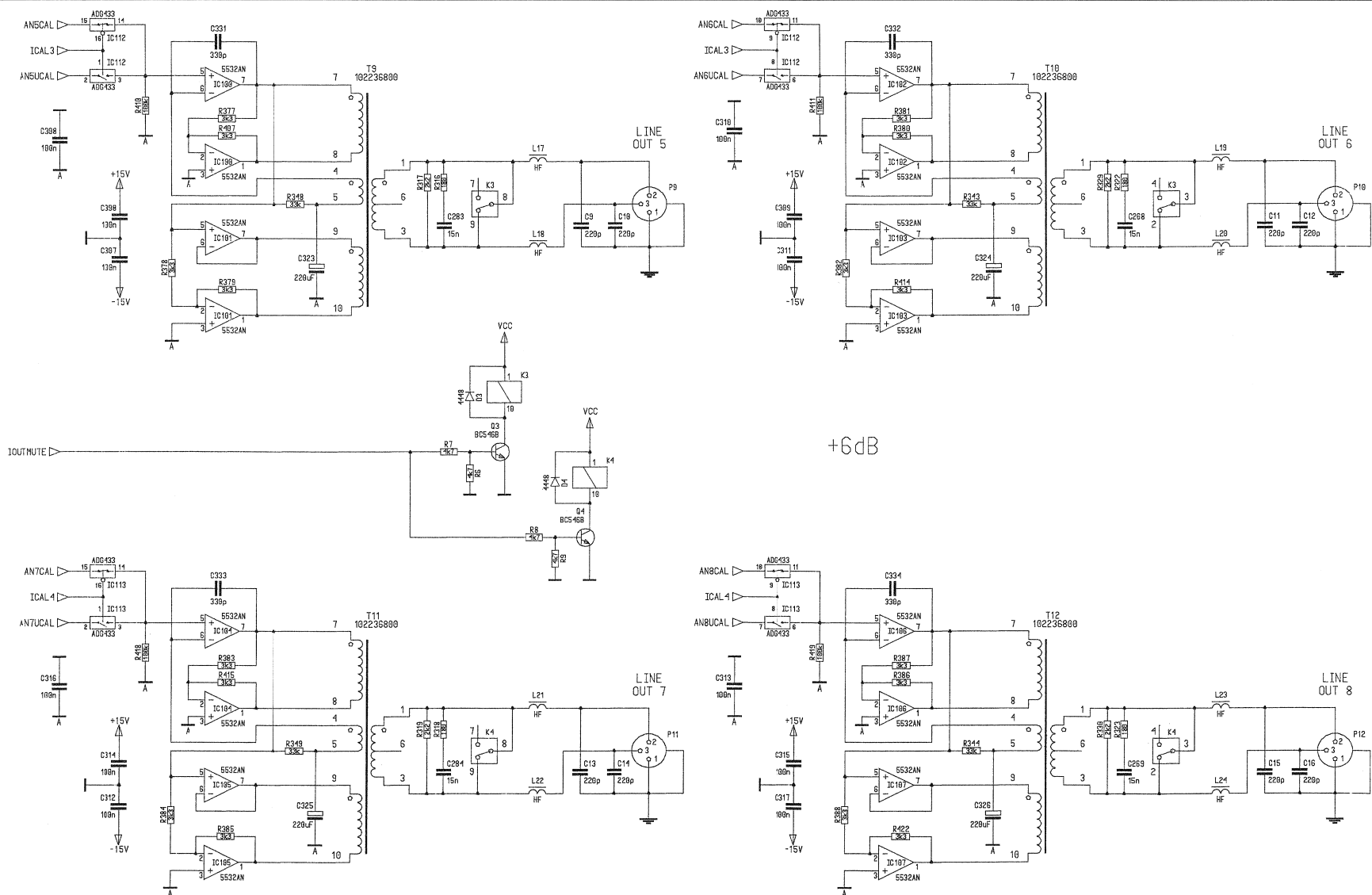

©11.10.96 / SG	©14.03.97 / SG		
MultiDAC: Line Out		PAGE 7 / 11	
STUDER		MAIN BOARD	
		SC 1.660.030.21	



Main Board 1.660.030.22

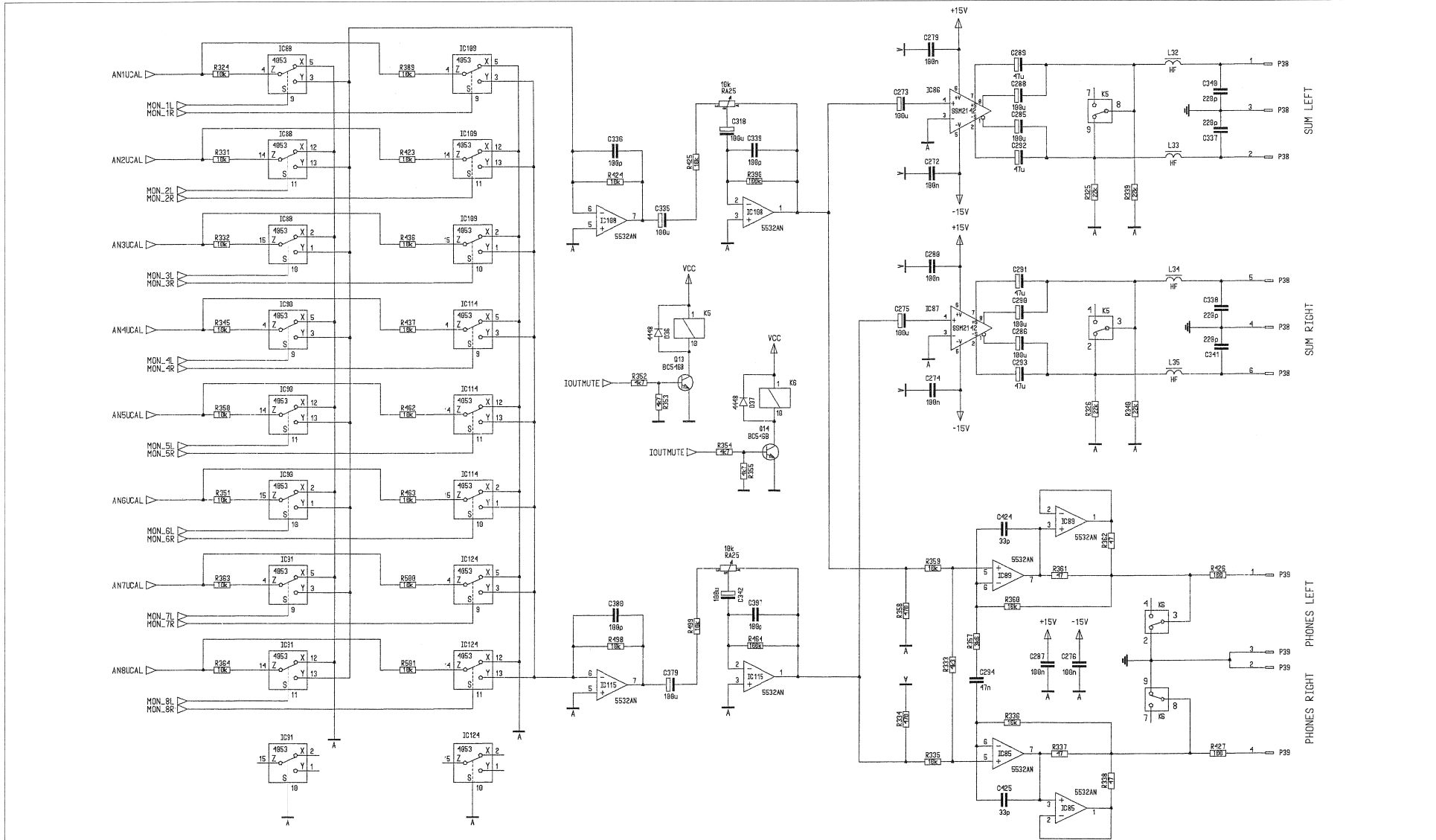

Main Board 1.660.030.22

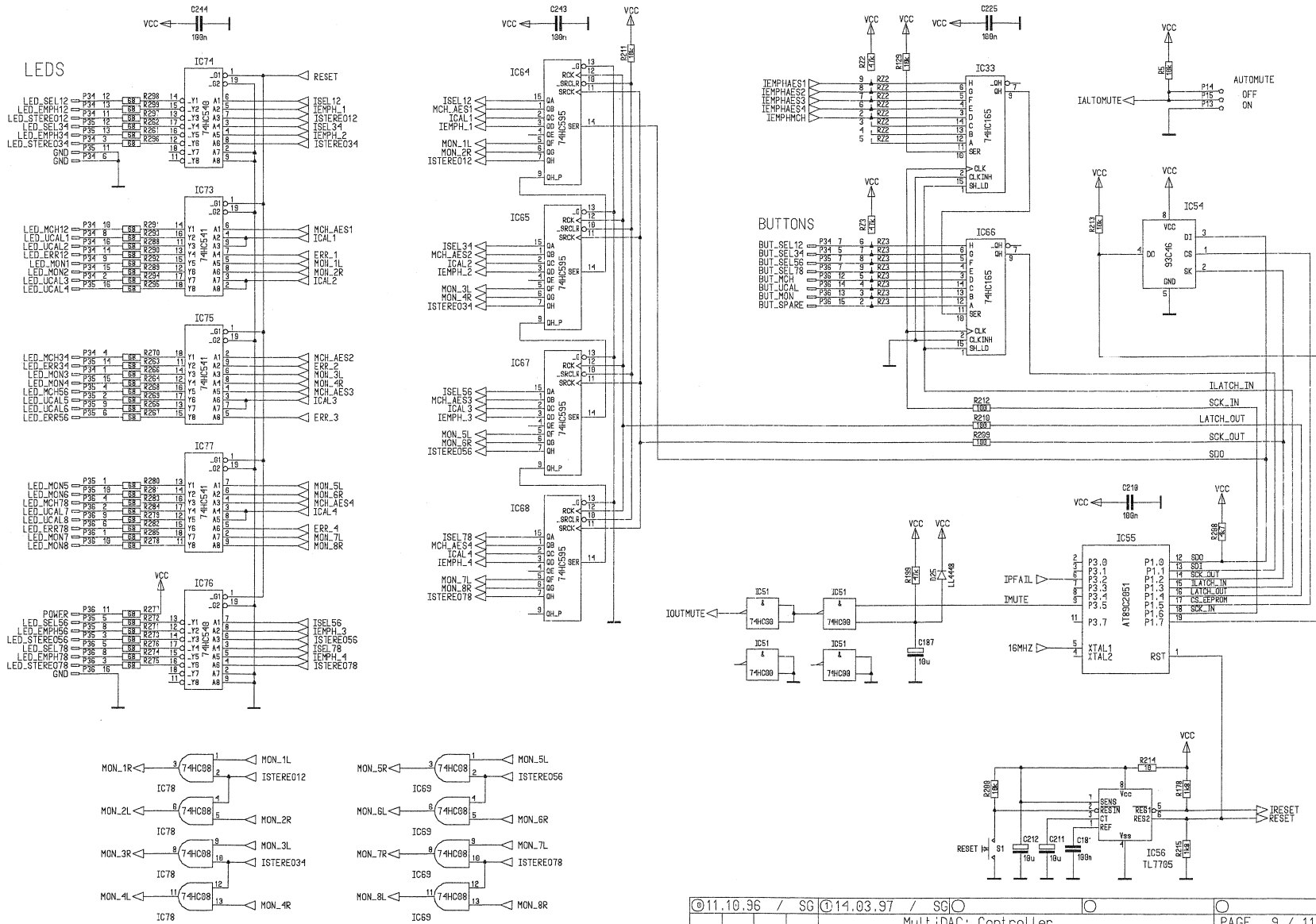

©11.10.96 / SG	©14.03.97 / SG		
MultiDAC: Controller		PAGE 9 / 11	
STUDER		MAIN BOARD	
		SC 1.660.030.21	



Main Board 1.660.030.22

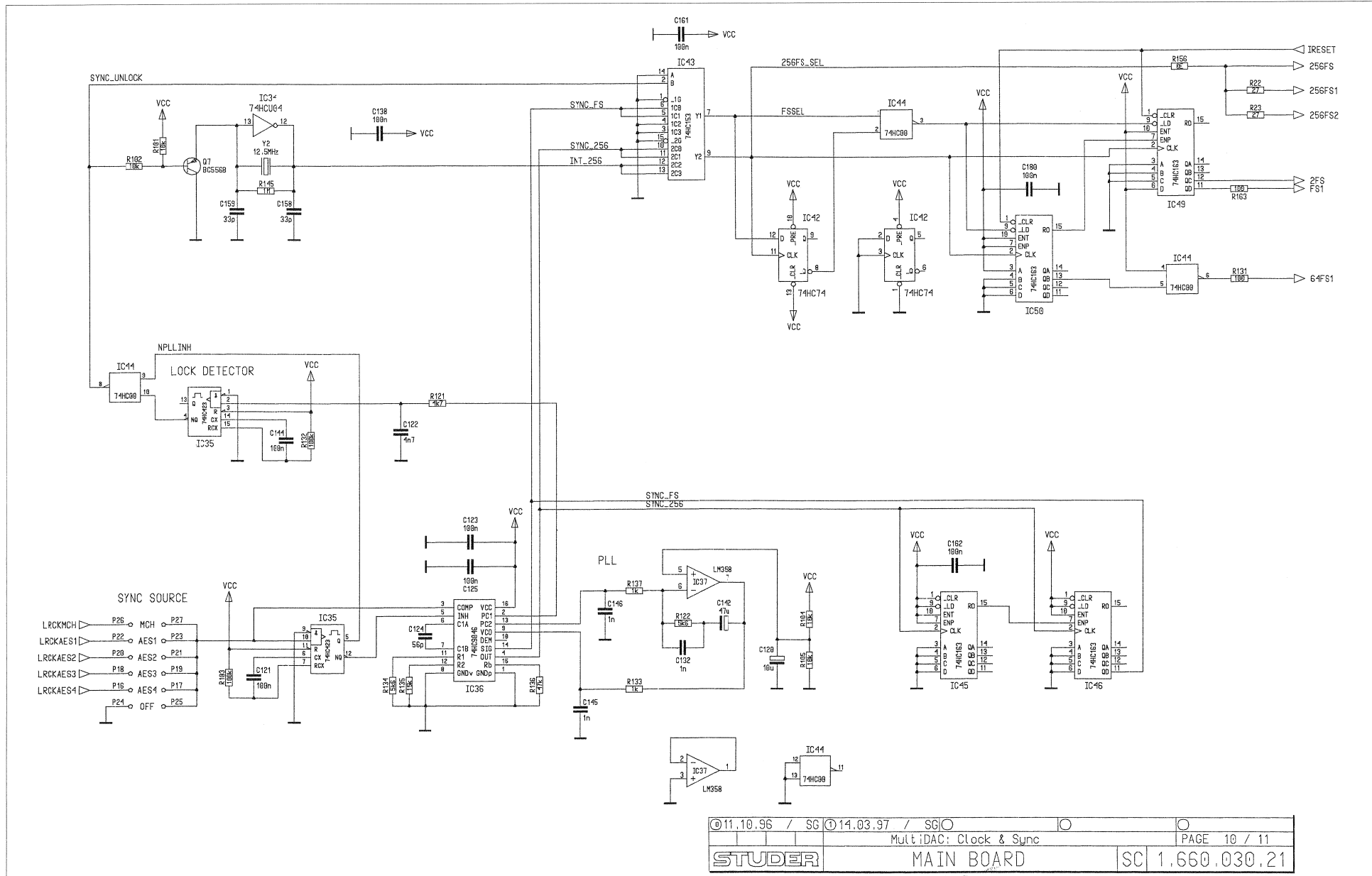

©11,10,96 / SG	©14,03,97 / SG		
MultiDAC: Clock & Sync		PAGE 10 / 11	
STUDER		MAIN BOARD	
		SC 1.660.030.21	

Main Board 1.660.030.22

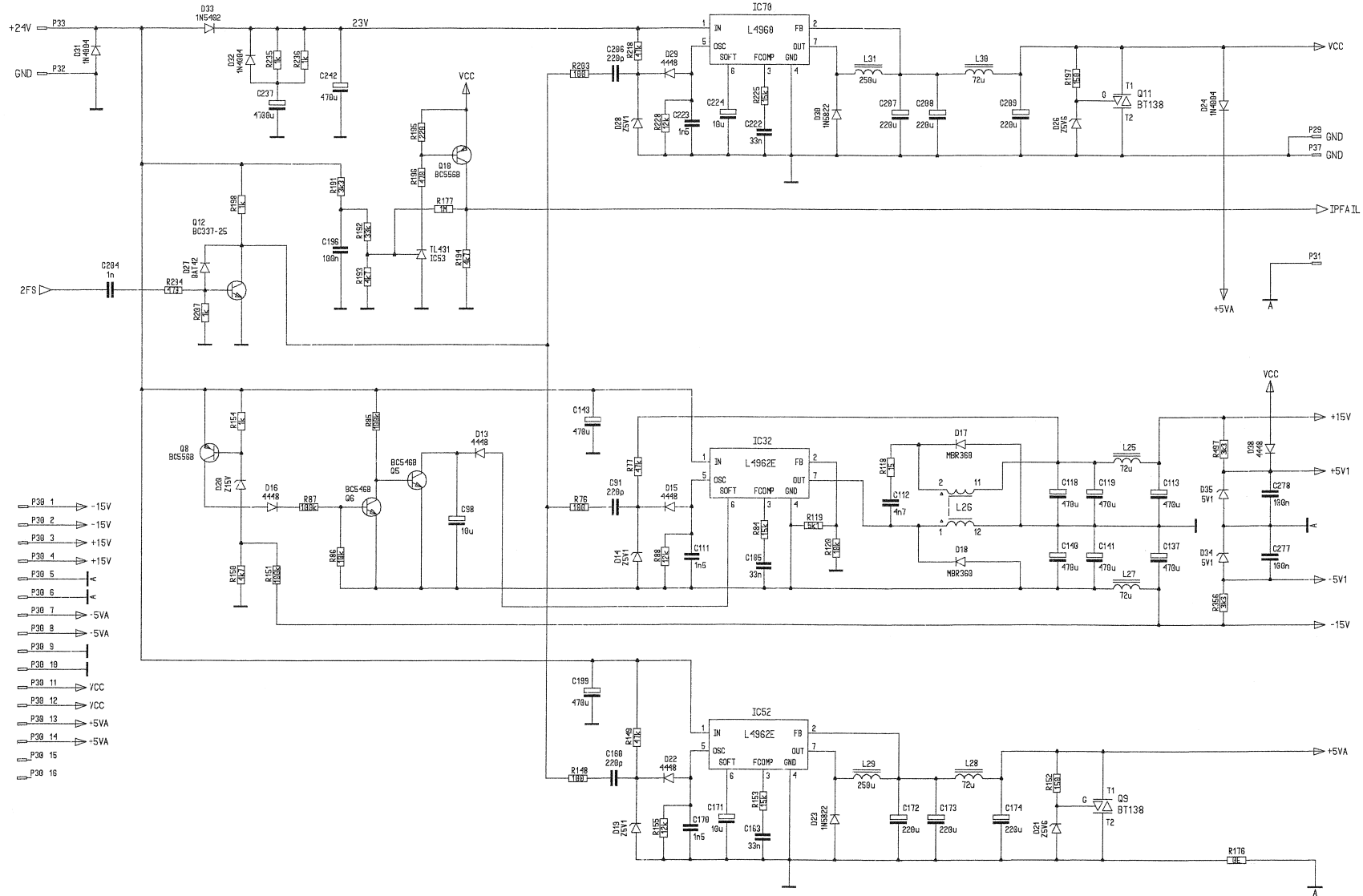

- P39 1 -15V
- P39 2 -15V
- P39 3 +15V
- P39 4 +15V
- P39 5 -
- P39 6 +5VA
- P39 7 -5VA
- P39 8 -
- P39 9 -
- P39 10 -
- P39 11 VCC
- P39 12 VCC
- P39 13 +5VA
- P39 14 +5VA
- P39 15 -
- P39 16 -

©11.10.96 / SG	©14.03.97 / SG	MultiDAC POWER SUPPLIES	PAGE 11 / 11
STUDER		MAIN BOARD	SC 1.660.030.21



Main Board I.660.030.22

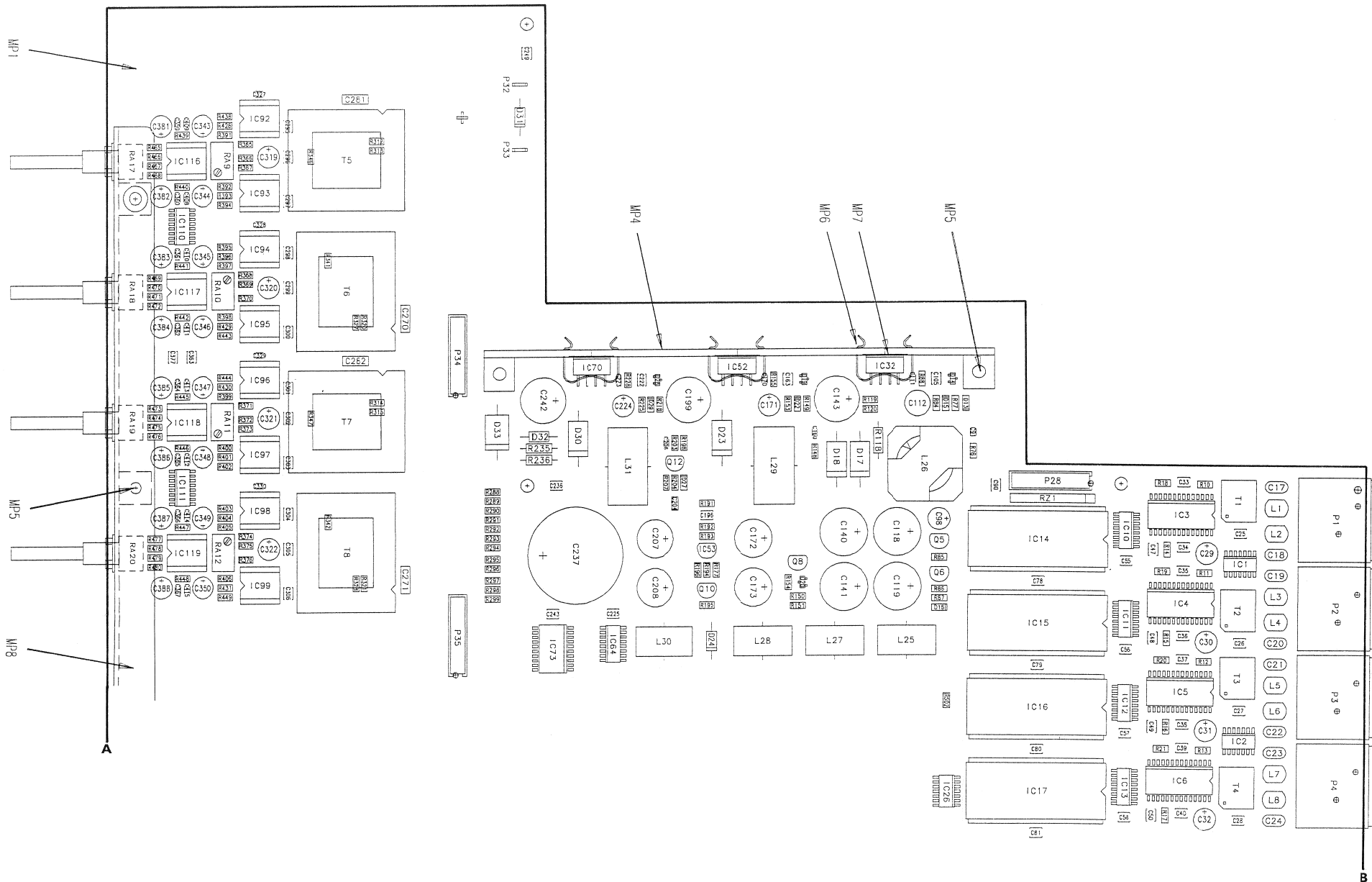

Main Board I.660.030.22

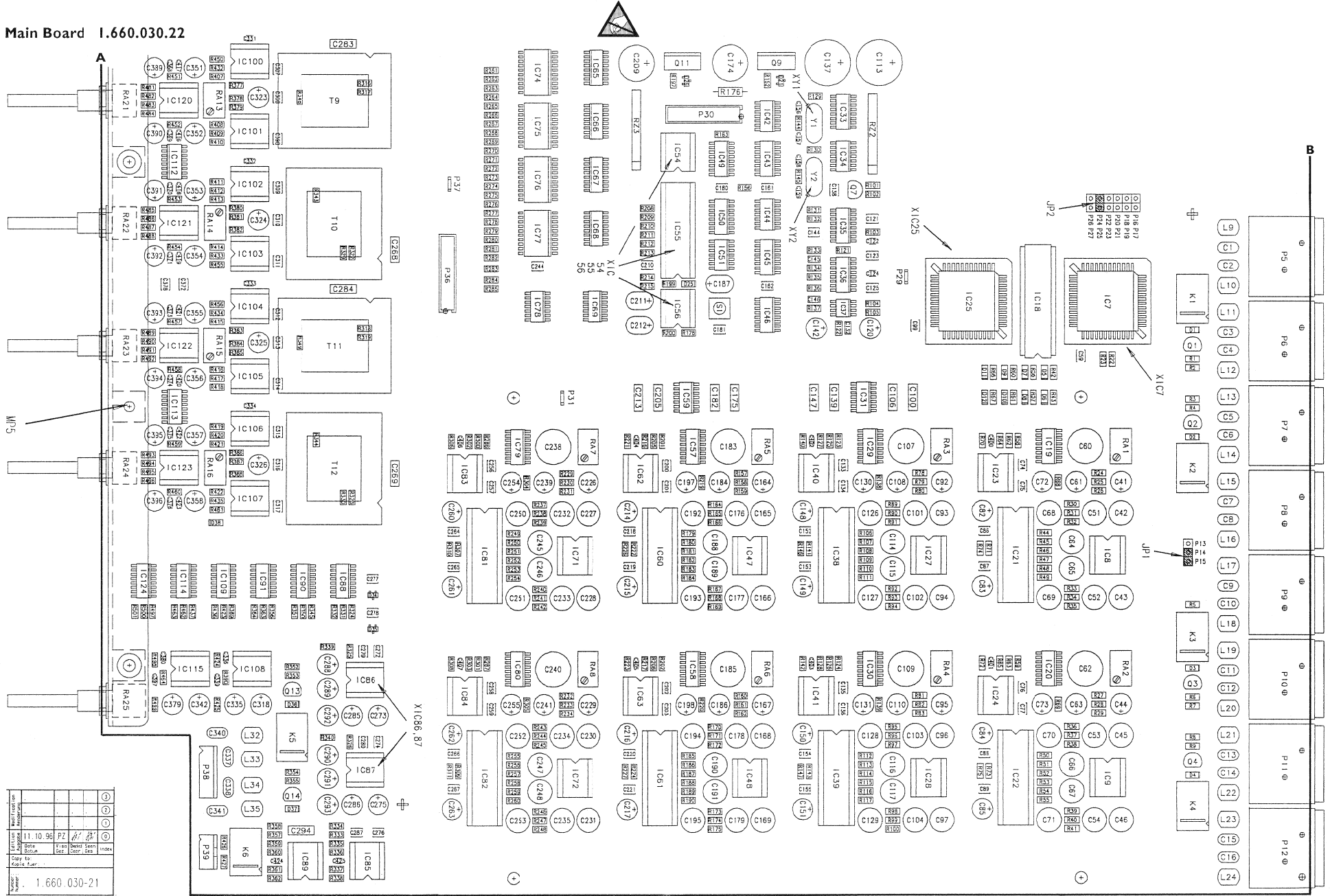

Rev.	1	11.10.96	PZ				
Date	11.10.96						
Drawn	PZ						
Checked							
Approved							
Design							
Part No.	I.660.030.22						
Rev.	1						
Drawn	PZ						
Checked							
Approved							
Design							
Part No.	I.660.030.22						
Rev.	1						



Main Board I.660.030.22

Table with 5 columns: Idx., Pos., Part No., Qty., Type/Val., Description. It lists various electronic components such as resistors, capacitors, and integrated circuits with their respective quantities and descriptions.



Main Board 1.660.030.22

Idx.	Pos.	Part No.	Qty.	Type/Val.	Description	Idx.	Pos.	Part No.	Qty.	Type/Val.	Description
0	C 365	59.60.0101		100p	CER 63V, 5%, COG, 0805	0	D 31	50.04.0105		1N4004	D 1 N 4004 ... 1 N 4007
0	C 366	59.60.0101		100p	CER 63V, 5%, COG, 0805	0	D 32	50.04.0105		1N4004	D 1 N 4004 ... 1 N 4007
0	C 367	59.60.0101		100p	CER 63V, 5%, COG, 0805	0	D 33	50.04.0507		1N5402	D 1 N 5402,
0	C 368	59.60.0101		100p	CER 63V, 5%, COG, 0805	0	D 34	50.60.9010		5V1	5%, 0.2W, SOT 23
0	C 369	59.60.0101		100p	CER 63V, 5%, COG, 0805	0	D 35	50.60.9010		5V1	5%, 0.2W, SOT 23
0	C 370	59.60.0101		100p	CER 63V, 5%, COG, 0805	0	D 36	50.60.8001		4448	D LL 4448 SOD 80
0	C 371	59.60.0101		100p	CER 63V, 5%, COG, 0805	0	D 37	50.60.8001		4448	D LL 4448 SOD 80
0	C 372	59.60.1104		100n	CER 63V, 10%, X7R, 1210	0	D 38	50.60.8001		4448	D LL 4448 SOD 80
0	C 373	59.60.0101		100p	CER 63V, 5%, COG, 0805	0	IC 1	50.62.1000		74HC 00	74 HC 00
0	C 374	59.60.0101		100p	CER 63V, 5%, COG, 0805	0	IC 2	50.62.1000		74HC 00	74 HC 00
0	C 375	59.60.0101		100p	CER 63V, 5%, COG, 0805	0	IC 3	50.62.0913		CS8412	AES-Receiver
0	C 376	59.60.0101		100p	CER 63V, 5%, COG, 0805	0	IC 4	50.62.0913		CS8412	AES-Receiver
0	C 377	59.60.1104		100n	CER 63V, 10%, X7R, 1210	0	IC 5	50.62.0913		CS8412	AES-Receiver
0	C 378	59.60.1104		100n	CER 63V, 10%, X7R, 1210	0	IC 6	50.62.0913		CS8412	AES-Receiver
0	C 379	59.22.4002		100uF	EL 16V, 20%, RM5	0	IC 7	1.660.032.21			SW 030.XX (SUBARA,50634201)
0	C 380	59.60.0101		100p	CER 63V, 5%, COG, 0805	0	IC 8	50.09.0106		5532AN	IC NE 5532 AN, NE 5532 AN, A
0	C 381	59.22.3003		220u	EL 10V, 20%, RM5	0	IC 9	50.09.0106		5532AN	IC NE 5532 AN, NE 5532 AN, A
0	C 382	59.22.3003		220u	EL 10V, 20%, RM5	0	IC 10	50.62.1157		74HC157	74 HC 157
0	C 383	59.22.3003		220u	EL 10V, 20%, RM5	0	IC 11	50.62.1157		74HC157	74 HC 157
0	C 384	59.22.3003		220u	EL 10V, 20%, RM5	0	IC 12	50.62.1157		74HC157	74 HC 157
0	C 385	59.22.3003		220u	EL 10V, 20%, RM5	0	IC 13	50.62.1157		74HC157	74 HC 157
0	C 386	59.22.3003		220u	EL 10V, 20%, RM5	0	IC 14	50.13.0204		IC AD 1890 JN	, A
0	C 387	59.22.3003		220u	EL 10V, 20%, RM5	0	IC 15	50.13.0204		IC AD 1890 JN	, A
0	C 388	59.22.3003		220u	EL 10V, 20%, RM5	0	IC 16	50.13.0204		IC AD 1890 JN	, A
0	C 389	59.22.3003		220u	EL 10V, 20%, RM5	0	IC 17	50.13.0204		IC AD 1890 JN	, A
0	C 390	59.22.3003		220u	EL 10V, 20%, RM5	0	IC 18	50.14.1009		CY7C128-35	IC MCM 2018 A - 35 , A
0	C 391	59.22.3003		220u	EL 10V, 20%, RM5	0	IC 19	50.62.8053		4053	IC .. 74 HC 4053 . , A
0	C 392	59.22.3003		220u	EL 10V, 20%, RM5	0	IC 20	50.62.8053		4053	IC .. 74 HC 4053 . , A
0	C 393	59.22.3003		220u	EL 10V, 20%, RM5	0	IC 21	50.19.0114		D/A Conv	IC CS 4329-KP,
0	C 394	59.22.3003		220u	EL 10V, 20%, RM5	0	IC 22	50.19.0114		D/A Conv	IC CS 4329-KP,
0	C 395	59.22.3003		220u	EL 10V, 20%, RM5	0	IC 23	50.09.0117		MC33078	IC MC 33078 P
0	C 396	59.22.3003		220u	EL 10V, 20%, RM5	0	IC 24	50.09.0117		MC33078	IC MC 33078 P
0	C 397	59.60.0101		100p	CER 63V, 5%, COG, 0805	0	IC 25	1.660.033.20			SW 030.XX (SUBARB,50634202)
0	C 398	59.60.1104		100n	CER 63V, 10%, X7R, 1210	0	IC 26	50.62.1032		74HC 32	74 HC 32
0	C 400	59.60.0330		33p	CER 63V, 5%, COG, 0805	0	IC 27	50.09.0106		5532AN	IC NE 5532 AN, NE 5532 AN, A
0	C 401	59.60.0330		33p	CER 63V, 5%, COG, 0805	0	IC 28	50.09.0106		5532AN	IC NE 5532 AN, NE 5532 AN, A
0	C 402	59.60.0330		33p	CER 63V, 5%, COG, 0805	0	IC 29	50.62.8053		4053	IC .. 74 HC 4053 . , A
0	C 403	59.60.0330		33p	CER 63V, 5%, COG, 0805	0	IC 30	50.62.8053		4053	IC .. 74 HC 4053 . , A
0	C 404	59.60.0330		33p	CER 63V, 5%, COG, 0805	0	IC 31	50.62.1014		74HC 14	74 HC 14
0	C 405	59.60.0330		33p	CER 63V, 5%, COG, 0805	0	IC 32	50.10.0118		L4962	IC L 4962 E,
0	C 406	59.60.0330		33p	CER 63V, 5%, COG, 0805	0	IC 33	50.62.1165		74HC165	74 HC 165
0	C 407	59.60.0330		33p	CER 63V, 5%, COG, 0805	0	IC 34	50.62.1904		74HC165	IC .. 74 HCU 04 . , A
0	C 408	59.60.0330		33p	CER 63V, 5%, COG, 0805	0	IC 35	50.62.1423		74HC423	74 HC 423
0	C 409	59.60.0330		33p	CER 63V, 5%, COG, 0805	0	IC 36	50.62.4946		74HCT9046	IC .. 74 HCT 9046 . , A
0	C 410	59.60.0330		33p	CER 63V, 5%, COG, 0805	0	IC 37	50.61.0202		LM358	IC LM 358 D , A
0	C 411	59.60.0330		33p	CER 63V, 5%, COG, 0805	0	IC 38	50.19.0114		D/A Conv	IC CS 4329-KP,
0	C 412	59.60.0330		33p	CER 63V, 5%, COG, 0805	0	IC 39	50.19.0114		D/A Conv	IC CS 4329-KP,
0	C 413	59.60.0330		33p	CER 63V, 5%, COG, 0805	0	IC 40	50.09.0117		MC33078	IC MC 33078 P
0	C 414	59.60.0330		33p	CER 63V, 5%, COG, 0805	0	IC 41	50.09.0117		MC33078	IC MC 33078 P
0	C 415	59.60.0330		33p	CER 63V, 5%, COG, 0805	0	IC 42	50.62.1074		74HC 74	74 HC 74
0	C 416	59.60.0330		33p	CER 63V, 5%, COG, 0805	0	IC 43	50.62.1153		74HC153	74 HC 153
0	C 417	59.60.0330		33p	CER 63V, 5%, COG, 0805	0	IC 44	50.62.1000		74HC 00	74 HC 00
0	C 418	59.60.0330		33p	CER 63V, 5%, COG, 0805	0	IC 45	50.62.1163		74HC163	74 HC 163
0	C 419	59.60.0330		33p	CER 63V, 5%, COG, 0805	0	IC 46	50.62.1163		74HC163	74 HC 163
0	C 420	59.60.0330		33p	CER 63V, 5%, COG, 0805	0	IC 47	50.09.0106		5532AN	IC NE 5532 AN, NE 5532 AN, A
0	C 421	59.60.0330		33p	CER 63V, 5%, COG, 0805	0	IC 48	50.09.0106		5532AN	IC NE 5532 AN, NE 5532 AN, A
0	C 422	59.60.0330		33p	CER 63V, 5%, COG, 0805	0	IC 49	50.62.1163		74HC163	74 HC 163
0	C 423	59.60.0330		33p	CER 63V, 5%, COG, 0805	0	IC 50	50.62.1163		74HC163	74 HC 163
0	C 424	59.60.0330		33p	CER 63V, 5%, COG, 0805	0	IC 51	50.62.1000		74HC 00	74 HC 00
0	C 425	59.60.0330		33p	CER 63V, 5%, COG, 0805	0	IC 52	50.10.0118		L4962	IC L 4962 E,
0	D 1	50.60.8001		4448	D LL 4448	0	IC 53	50.10.0106		TL431	IC TL 431 CLP,
0	D 2	50.60.8001		4448	D LL 4448	0	IC 54	50.14.2103		HY93C46S	EEPROM 64 * 16, serial
0	D 3	50.60.8001		4448	D LL 4448	0	IC 55	1.660.031.20			SW D19 MultiDAC
0	D 4	50.60.8001		4448	D LL 4448	0	IC 56	50.11.0122		TL7705	IC TL 7705 ACP,
0	D 5	50.60.8001		4448	D LL 4448	0	IC 57	50.62.8053		4053	IC .. 74 HC 4053 . , A
0	D 6	50.60.8001		4448	D LL 4448	0	IC 58	50.62.8053		4053	IC .. 74 HC 4053 . , A
0	D 7	50.60.8001		4448	D LL 4448	0	IC 59	50.62.1014		74HC 14	74 HC 14
0	D 8	50.60.8001		4448	D LL 4448	0	IC 60	50.19.0114		D/A Conv	IC CS 4329-KP,
0	D 9	50.60.8001		4448	D LL 4448	0	IC 61	50.19.0114		D/A Conv	IC CS 4329-KP,
0	D 10	50.60.8001		4448	D LL 4448	0	IC 62	50.09.0117		MC33078	IC MC 33078 P
0	D 11	50.60.8001		4448	D LL 4448	0	IC 63	50.09.0117		MC33078	IC MC 33078 P
0	D 12	50.60.8001		4448	D LL 4448	0	IC 64	50.62.1595		74HC595	74 HC 595
0	D 13	50.60.8001		4448	D LL 4448	0	IC 65	50.62.1595		74HC595	74 HC 595
0	D 14	50.60.9010		5V1	5%, 0.2W, SOT 23	0	IC 66	50.62.1165		74HC165	74 HC 165
0	D 15	50.60.8001		4448	D LL 4448	0	IC 67	50.62.1595		74HC595	74 HC 595
0	D 16	50.60.8001		4448	D LL 4448	0	IC 68	50.62.1595		74HC595	74 HC 595
0	D 17	50.04.0526		MBR360	D MBR 360, SB 360, 31 DQ 05,	0	IC 69	50.62.1008		74HC 08	74 HC 08
0	D 18	50.04.0526		MBR360	D MBR 360, SB 360, 31 DQ 05,	0	IC 70	50.10.0122		L4960	L 4960
0	D 19	50.60.9010		5V1	5%, 0.2W, SOT 23	0	IC 71	50.09.0106		5532AN	IC NE 5532 AN, NE 5532 AN, A
0	D 20	50.60.9021		15V	5%, 0.2W, SOT 23	0	IC 72	50.09.0106		5532AN	IC NE 5532 AN, NE 5532 AN, A
0	D 21	50.60.9011		5V6	5%, 0.2W, SOT 23	0	IC 73	50.62.1541		74HC541	74 HC 541
0	D 22	50.60.8001		4448	D LL 4448	0	IC 74	50.62.1540		74HC540	74 HC 540
0	D 23	50.04.0519		1N5922	3A, Schottky	0	IC 75	50.62.1541		74HC541	74 HC 541
0	D 24	50.04.0105		1N4004	D 1 N 4004 ... 1 N 4007	0	IC 76	50.62.1540		74HC540	74 HC 540
0	D 25	50.60.8001		4448	D LL 4448	0	IC 77	50.62.1541		74HC541	74 HC 541
0	D 26	50.60.9011		5V6	5%, 0.2W, SOT 23	0	IC 78	50.62.1008		74HC 08	74 HC 08
0	D 27	50.60.8101		BAS85	D BAS 85	0	IC 79	50.62.8053		4053	IC .. 74 HC 4053 . , A
0	D 28	50.60.9010		5V1	5%, 0.2W, SOT 23	0	IC 80	50.62.8053		4053	IC .. 74 HC 4053 . , A
0	D 29	50.60.8001		4448	D LL 4448	0	IC 81	50.19.0114		D/A Conv	IC CS 4329-KP,
0	D 30	50.04.0519		1N5922	3A, Schottky						



Main Board I.660.030.22

Ixd.	Pos.	Part No.	Qty.	Type/Val.	Description	Ixd.	Pos.	Part No.	Qty.	Type/Val.	Description
0	IC 82	50.19.0114		D/A Conv	IC CS 4329-KP,	0	MP 1	1.660.030.12	1 pce		MAIN BOARD 8CH,PCB /A
0	IC 83	50.09.0117		MC33078	IC MC 33078 P	0	MP 2	43.01.0108	1 pce	Label	ESE-WARNschild
0	IC 84	50.09.0117		MC33078	IC MC 33078 P	0	MP 3	1.660.030.10	1 pce		NR-ETIKETTE 5 X 20
0	IC 85	50.09.0106		5532AN	IC NE 5532 AN, NE 5532 AN, A	0	MP 4	1.660.030.01	1 pce		Kühlblech
0	IC 86	50.09.0124		2142	IC SSM 2142 P	0	MP 5	21.38.0354	4 pcs		Z - SCHR. KS, A2, M 3 * 6
0	IC 87	50.09.0174		2142	IC SSM 2142 P	0	MP 6	50.20.2003	3 pcs		Montageclip zu TO 220. N/SOL.
0	IC 88	50.62.8053		4053	IC .. 74 HC 4053 . ,A	0	MP 7	50.20.0305	3 pcs		TO 220 GLIMMERSCHEIBE GEFETTET
0	IC 89	50.09.0106		5532AN	IC NE 5532 AN, NE 5532 AN, A	0	MP 8	1.660.030.02	1 pce		Halter Potentiometer
0	IC 90	50.62.8053		4053	IC .. 74 HC 4053 . ,A						
0	IC 91	50.62.8053		4053	IC .. 74 HC 4053 . ,A	0	P 1	54.21.2203	3p		XLR 3p PCB WINKEL
0	IC 92	50.09.0106		5532AN	IC NE 5532 AN, NE 5532 AN, A	0	P 2	54.21.2203	3p		XLR 3p PCB WINKEL
0	IC 93	50.09.0106		5532AN	IC NE 5532 AN, NE 5532 AN, A	0	P 3	54.21.2203	3p		XLR 3p PCB WINKEL
0	IC 94	50.09.0106		5532AN	IC NE 5532 AN, NE 5532 AN, A	0	P 4	54.21.2203	3p		XLR 3p PCB WINKEL
0	IC 95	50.09.0106		5532AN	IC NE 5532 AN, NE 5532 AN, A	0	P 5	54.21.2202	3p		XLR 3p PCB WINKEL
0	IC 96	50.09.0106		5532AN	IC NE 5532 AN, NE 5532 AN, A	0	P 6	54.21.2202	3p		XLR 3p PCB WINKEL
0	IC 97	50.09.0106		5532AN	IC NE 5532 AN, NE 5532 AN, A	0	P 7	54.21.2202	3p		XLR 3p PCB WINKEL
0	IC 98	50.09.0106		5532AN	IC NE 5532 AN, NE 5532 AN, A	0	P 8	54.21.2202	3p		XLR 3p PCB WINKEL
0	IC 99	50.09.0106		5532AN	IC NE 5532 AN, NE 5532 AN, A	0	P 9	54.21.2202	3p		XLR 3p PCB WINKEL
0	IC 100	50.09.0106		5532AN	IC NE 5532 AN, NE 5532 AN, A	0	P 10	54.21.2202	3p		XLR 3p PCB WINKEL
0	IC 101	50.09.0106		5532AN	IC NE 5532 AN, NE 5532 AN, A	0	P 11	54.21.2202	3p		XLR 3p PCB WINKEL
0	IC 102	50.09.0106		5532AN	IC NE 5532 AN, NE 5532 AN, A	0	P 12	54.21.2202	3p		XLR 3p PCB WINKEL
0	IC 103	50.09.0106		5532AN	IC NE 5532 AN, NE 5532 AN, A	0	P 13	54.01.0020	1p		Pin 0.63*0.63
0	IC 104	50.09.0106		5532AN	IC NE 5532 AN, NE 5532 AN, A	0	P 14	54.01.0020	1p		Pin 0.63*0.63
0	IC 105	50.09.0106		5532AN	IC NE 5532 AN, NE 5532 AN, A	0	P 15	54.01.0020	1p		Pin 0.63*0.63
0	IC 106	50.09.0106		5532AN	IC NE 5532 AN, NE 5532 AN, A	0	P 16	54.01.0020	1p		Pin 0.63*0.63
0	IC 107	50.09.0106		5532AN	IC NE 5532 AN, NE 5532 AN, A	0	P 17	54.01.0020	1p		Pin 0.63*0.63
0	IC 108	50.09.0106		5532AN	IC NE 5532 AN, NE 5532 AN, A	0	P 18	54.01.0020	1p		Pin 0.63*0.63
0	IC 109	50.62.8053		4053	IC .. 74 HC 4053 . ,A	0	P 19	54.01.0020	1p		Pin 0.63*0.63
0	IC 110	50.61.8202		ADG433	IC ADG 433 BR ,A	0	P 20	54.01.0020	1p		Pin 0.63*0.63
0	IC 111	50.61.8202		ADG433	IC ADG 433 BR ,A	0	P 21	54.01.0020	1p		Pin 0.63*0.63
0	IC 112	50.61.8202		ADG433	IC ADG 433 BR ,A	0	P 22	54.01.0020	1p		Pin 0.63*0.63
0	IC 113	50.61.8202		ADG433	IC ADG 433 BR ,A	0	P 23	54.01.0020	1p		Pin 0.63*0.63
0	IC 114	50.62.8053		4053	IC .. 74 HC 4053 . ,A	0	P 24	54.01.0020	1p		Pin 0.63*0.63
0	IC 115	50.09.0106		5532AN	IC NE 5532 AN, NE 5532 AN, A	0	P 25	54.01.0020	1p		Pin 0.63*0.63
0	IC 116	50.09.0117		MC33078	IC MC 33078 P	0	P 26	54.01.0020	1p		Pin 0.63*0.63
0	IC 117	50.09.0117		MC33078	IC MC 33078 P	0	P 27	54.01.0020	1p		Pin 0.63*0.63
0	IC 118	50.09.0117		MC33078	IC MC 33078 P	0	P 28	54.14.5516	16p		J PCB-BUCHSE GERADE 16 P
0	IC 119	50.09.0117		MC33078	IC MC 33078 P	0	P 29	54.02.0320	1p		Flatpin, 2,8*0.8mm
0	IC 120	50.09.0117		MC33078	IC MC 33078 P	0	P 30	54.14.5516	16p		J PCB-BUCHSE GERADE 16 P
0	IC 121	50.09.0117		MC33078	IC MC 33078 P	0	P 31	54.02.0320	1p		Flatpin, 2,8*0.8mm
0	IC 122	50.09.0117		MC33078	IC MC 33078 P	0	P 32	54.02.0320	1p		Flatpin, 2,8*0.8mm
0	IC 123	50.09.0117		MC33078	IC MC 33078 P	0	P 33	54.02.0320	1p		Flatpin, 2,8*0.8mm
0	IC 124	50.62.8053		4053	IC .. 74 HC 4053 . ,A	0	P 34	54.14.5516	16p		J PCB-BUCHSE GERADE 16 P
	JP 1	54.01.0021		Jumper	0.63 * 0.63mm	0	P 35	54.14.5516	16p		J PCB-BUCHSE GERADE 16 P
	JP 2	54.01.0021		Jumper	0.63 * 0.63mm	0	P 36	54.14.5516	16p		J PCB-BUCHSE GERADE 16 P
						0	P 37	54.02.0320	1p		Flatpin, 2,8*0.8mm
						0	P 38	54.99.0228	6p		EI-Stecker, gerade
						0	P 39	54.99.0213	4P		EI-Stecker, gerade
	K 1	56.04.0198		2u	5V, 125V/2A, AG/AU	0	Q 1	50.03.0491		BC546B	BC 546 B NPN
	K 2	56.04.0198		2u	5V, 125V/2A, AG/AU	0	Q 2	50.03.0491		BC546B	BC 546 B NPN
	K 3	56.04.0198		2u	5V, 125V/2A, AG/AU	0	Q 3	50.03.0491		BC546B	BC 546 B NPN
	K 4	56.04.0198		2u	5V, 125V/2A, AG/AU	0	Q 4	50.03.0491		BC546B	BC 546 B NPN
	K 5	56.04.0198		2u	5V, 125V/2A, AG/AU	0	Q 5	50.03.0491		BC546B	BC 546 B NPN
	K 6	56.04.0198		2u	5V, 125V/2A, AG/AU	0	Q 6	50.03.0491		BC546B	BC 546 B NPN
	L 1	1.010.321.64		Wire	DRAHTBRUECKE U, 4.3* 5.0, 0,6	0	Q 7	50.03.0492		BC556B	BC 556 B PNP
	L 2	1.010.321.64		Wire	DRAHTBRUECKE U, 4.3* 5.0, 0,6	0	Q 8	50.03.0492		BC556B	BC 556 B PNP
	L 3	1.010.321.64		Wire	DRAHTBRUECKE U, 4.3* 5.0, 0,6	0	Q 9	50.09.0106		BT138	Q BT 138 - 500 TRIAC
	L 4	1.010.321.64		Wire	DRAHTBRUECKE U, 4.3* 5.0, 0,6	0	Q 10	50.03.0492		BC556B	BC 556 B PNP
	L 5	1.010.321.64		Wire	DRAHTBRUECKE U, 4.3* 5.0, 0,6	0	Q 11	50.09.0106		BT138	Q BT 138 - 500 TRIAC
	L 6	1.010.321.64		Wire	DRAHTBRUECKE U, 4.3* 5.0, 0,6	0	Q 12	50.03.0340		BC337-25	800mA, 45V, NPN
	L 7	1.010.321.64		Wire	DRAHTBRUECKE U, 4.3* 5.0, 0,6	0	Q 13	50.03.0491		BC546B	BC 546 B NPN
	L 8	1.010.321.64		Wire	DRAHTBRUECKE U, 4.3* 5.0, 0,6	0	Q 14	50.03.0491		BC546B	BC 546 B NPN
	L 9	62.01.0301		110MHz	BREITBAND-DROSSEL	0	R 1	57.60.1472	4K7		MF, 1%, 0204, E24
	L 10	62.01.0301		110MHz	BREITBAND-DROSSEL	0	R 2	57.60.1472	4K7		MF, 1%, 0204, E24
	L 11	62.01.0301		110MHz	BREITBAND-DROSSEL	0	R 3	57.60.1472	4K7		MF, 1%, 0204, E24
	L 12	62.01.0301		110MHz	BREITBAND-DROSSEL	0	R 4	57.60.1472	4K7		MF, 1%, 0204, E24
	L 13	62.01.0301		110MHz	BREITBAND-DROSSEL	0	R 5	57.60.1103	10K		MF, 1%, 0204, E24
	L 14	62.01.0301		110MHz	BREITBAND-DROSSEL	0	R 6	57.60.1472	4K7		MF, 1%, 0204, E24
	L 15	62.01.0301		110MHz	BREITBAND-DROSSEL	0	R 7	57.60.1472	4K7		MF, 1%, 0204, E24
	L 16	62.01.0301		110MHz	BREITBAND-DROSSEL	0	R 8	57.60.1472	4K7		MF, 1%, 0204, E24
	L 17	62.01.0301		110MHz	BREITBAND-DROSSEL	0	R 9	57.60.1472	4K7		MF, 1%, 0204, E24
	L 18	62.01.0301		110MHz	BREITBAND-DROSSEL	0	R 10	57.60.1100	10R		MF, 1%, 0204, E24
	L 19	62.01.0301		110MHz	BREITBAND-DROSSEL	0	R 11	57.60.1100	10R		MF, 1%, 0204, E24
	L 20	62.01.0301		110MHz	BREITBAND-DROSSEL	0	R 12	57.60.1100	10R		MF, 1%, 0204, E24
	L 21	62.01.0301		110MHz	BREITBAND-DROSSEL	0	R 13	57.60.1100	10R		MF, 1%, 0204, E24
	L 22	62.01.0301		110MHz	BREITBAND-DROSSEL	0	R 14	57.60.1102	1K		MF, 1%, 0204, E24
	L 23	62.01.0301		110MHz	BREITBAND-DROSSEL	0	R 15	57.60.1102	1K		MF, 1%, 0204, E24
	L 24	62.01.0301		110MHz	BREITBAND-DROSSEL	0	R 16	57.60.1102	1K		MF, 1%, 0204, E24
	L 25	62.03.0015		72uH	2A Toroid Chochoe	0	R 17	57.60.1102	1K		MF, 1%, 0204, E24
	L 26	1.022.651.00		250uH	STORAGE INDUCTOR 2*250UH	0	R 18	57.60.1221	220R		MF, 1%, 0204, E24
	L 27	62.03.0015		72uH	2A Toroid Chochoe	0	R 19	57.60.1221	220R		MF, 1%, 0204, E24
	L 28	62.03.0015		72uH	2A Toroid Chochoe	0	R 20	57.60.1221	220R		MF, 1%, 0204, E24
	L 29	62.03.0025		250uH	2A Toroid Chochoe	0	R 21	57.60.1221	220R		MF, 1%, 0204, E24
	L 30	62.03.0015		72uH	2A Toroid Chochoe	0	R 22	57.60.1270	27R		MF, 1%, 0204, E24
	L 31	62.03.0025		250uH	2A Toroid Chochoe	0	R 23	57.60.1270	27R		MF, 1%, 0204, E24
	L 32	62.01.0301		110MHz	BREITBAND-DROSSEL	0	R 24	57.60.1821	820R		MF, 1%, 0204, E24
	L 33	62.01.0301		110MHz	BREITBAND-DROSSEL	0	R 25	57.60.1104	100K		MF, 1%, 0204, E24
	L 34	62.01.0301		110MHz	BREITBAND-DROSSEL	0	R 26	57.60.1682	6K8		MF, 1%, 0204, E24
	L 35	62.01.0301		110MHz	BREITBAND-DROSSEL	0	R 27	57.60.1821	820R		MF, 1%, 0204, E24



Main Board I.660.030.22

Idx.	Pos.	Part No.	Qty.	Type/Val.	Description	Idx.	Pos.	Part No.	Qty.	Type/Val.	Description
0	R 28	57.60.1104	100K		MF, 1%, 0204, E24	0	R 118	57.11.3150	15R		MF, 1%, 0207
0	R 29	57.60.1682	6K8		MF, 1%, 0204, E24	0	R 119	57.60.1512	5K1		MF, 1%, 0204, E24
0	R 30	57.60.1133	13K		MF, 1%, 0204, E24	0	R 120	57.60.1103	10K		MF, 1%, 0204, E24
0	R 31	57.60.1332	3K3		MF, 1%, 0204, E24	0	R 121	57.60.1472	4K7		MF, 1%, 0204, E24
0	R 32	57.60.1332	3K3		MF, 1%, 0204, E24	0	R 122	57.60.1562	5K6		MF, 1%, 0204, E24
0	R 33	57.60.1332	3K3		MF, 1%, 0204, E24	0	R 123	57.60.1681	680R		MF, 1%, 0204, E24
0	R 34	57.60.1332	3K3		MF, 1%, 0204, E24	0	R 124	57.60.1681	680R		MF, 1%, 0204, E24
0	R 35	57.60.1133	13K		MF, 1%, 0204, E24	0	R 125	57.60.1162	1K6		MF, 1%, 0204, E24
0	R 36	57.60.1133	13K		MF, 1%, 0204, E24	0	R 126	57.60.1162	1K6		MF, 1%, 0204, E24
0	R 37	57.60.1332	3K3		MF, 1%, 0204, E24	0	R 127	57.60.1162	1K6		MF, 1%, 0204, E24
0	R 38	57.60.1332	3K3		MF, 1%, 0204, E24	0	R 128	57.60.1162	1K6		MF, 1%, 0204, E24
0	R 39	57.60.1332	3K3		MF, 1%, 0204, E24	0	R 129	57.60.1103	10K		MF, 1%, 0204, E24
0	R 40	57.60.1332	3K3		MF, 1%, 0204, E24	0	R 130	57.60.1470	47R		MF, 1%, 0204, E24
0	R 41	57.60.1133	13K		MF, 1%, 0204, E24	0	R 131	57.60.1101	100R		MF, 1%, 0204, E24
0	R 42	57.60.1474	470K		MF, 1%, 0204, E24	0	R 132	57.60.1104	100K		MF, 1%, 0204, E24
0	R 43	57.60.1474	470K		MF, 1%, 0204, E24	0	R 133	57.60.1102	1K		MF, 1%, 0204, E24
0	R 44	57.60.1133	13K		MF, 1%, 0204, E24	0	R 134	57.60.1562	5K6		MF, 1%, 0204, E24
0	R 45	57.60.1133	13K		MF, 1%, 0204, E24	0	R 135	57.60.1153	15K		MF, 1%, 0204, E24
0	R 46	57.60.1133	13K		MF, 1%, 0204, E24	0	R 136	57.60.1473	47K		MF, 1%, 0204, E24
0	R 47	57.60.1133	13K		MF, 1%, 0204, E24	0	R 137	57.60.1102	1K		MF, 1%, 0204, E24
0	R 48	57.60.1133	13K		MF, 1%, 0204, E24	0	R 138	57.60.1104	100K		MF, 1%, 0204, E24
0	R 49	57.60.1133	13K		MF, 1%, 0204, E24	0	R 139	57.60.1104	100K		MF, 1%, 0204, E24
0	R 50	57.60.1133	13K		MF, 1%, 0204, E24	0	R 140	57.60.1270	27R		MF, 1%, 0204, E24
0	R 51	57.60.1133	13K		MF, 1%, 0204, E24	0	R 141	57.60.1100	10R		MF, 1%, 0204, E24
0	R 52	57.60.1133	13K		MF, 1%, 0204, E24	0	R 142	57.60.1270	27R		MF, 1%, 0204, E24
0	R 53	57.60.1133	13K		MF, 1%, 0204, E24	0	R 143	57.60.1100	10R		MF, 1%, 0204, E24
0	R 54	57.60.1133	13K		MF, 1%, 0204, E24	0	R 144	57.60.1105	1M		MF, 1%, 0204, E24
0	R 55	57.60.1133	13K		MF, 1%, 0204, E24	0	R 145	57.60.1105	1M		MF, 1%, 0204, E24
0	R 56	57.60.1474	470K		MF, 1%, 0204, E24	0	R 146	57.60.1100	10R		MF, 1%, 0204, E24
0	R 57	57.60.1474	470K		MF, 1%, 0204, E24	0	R 147	57.60.1100	10R		MF, 1%, 0204, E24
0	R 58	57.60.1681	680R		MF, 1%, 0204, E24	0	R 148	57.60.1101	100R		MF, 1%, 0204, E24
0	R 59	57.60.1681	680R		MF, 1%, 0204, E24	0	R 149	57.60.1473	47K		MF, 1%, 0204, E24
0	R 60	57.60.1474	470K		MF, 1%, 0204, E24	0	R 150	57.60.1472	4K7		MF, 1%, 0204, E24
0	R 61	57.60.1474	470K		MF, 1%, 0204, E24	0	R 151	57.60.1104	100K		MF, 1%, 0204, E24
0	R 62	57.60.1162	1K6		MF, 1%, 0204, E24	0	R 152	57.60.1151	150R		MF, 1%, 0204, E24
0	R 63	57.60.1162	1K6		MF, 1%, 0204, E24	0	R 153	57.60.1153	15K		MF, 1%, 0204, E24
0	R 64	57.60.1162	1K6		MF, 1%, 0204, E24	0	R 154	57.60.1102	1K		MF, 1%, 0204, E24
0	R 65	57.60.1162	1K6		MF, 1%, 0204, E24	0	R 155	57.60.1123	12K		MF, 1%, 0204, E24
0	R 66	57.60.1474	470K		MF, 1%, 0204, E24	0	R 156	57.60.1000	0R0		MF, 0204
0	R 67	57.60.1474	470K		MF, 1%, 0204, E24	0	R 157	57.60.1821	820R		MF, 1%, 0204, E24
0	R 68	57.60.1104	100K		MF, 1%, 0204, E24	0	R 158	57.60.1104	100K		MF, 1%, 0204, E24
0	R 69	57.60.1104	100K		MF, 1%, 0204, E24	0	R 159	57.60.1682	6K8		MF, 1%, 0204, E24
0	R 70	57.60.1270	27R		MF, 1%, 0204, E24	0	R 160	57.60.1821	820R		MF, 1%, 0204, E24
0	R 71	57.60.1100	10R		MF, 1%, 0204, E24	0	R 161	57.60.1104	100K		MF, 1%, 0204, E24
0	R 72	57.60.1270	27R		MF, 1%, 0204, E24	0	R 162	57.60.1682	6K8		MF, 1%, 0204, E24
0	R 73	57.60.1100	10R		MF, 1%, 0204, E24	0	R 163	57.60.1101	100R		MF, 1%, 0204, E24
0	R 74	57.60.1100	10R		MF, 1%, 0204, E24	0	R 164	57.60.1133	13K		MF, 1%, 0204, E24
0	R 75	57.60.1100	10R		MF, 1%, 0204, E24	0	R 165	57.60.1332	3K3		MF, 1%, 0204, E24
0	R 76	57.60.1101	100R		MF, 1%, 0204, E24	0	R 166	57.60.1332	3K3		MF, 1%, 0204, E24
0	R 77	57.60.1473	47K		MF, 1%, 0204, E24	0	R 167	57.60.1332	3K3		MF, 1%, 0204, E24
0	R 78	57.60.1821	820R		MF, 1%, 0204, E24	0	R 168	57.60.1332	3K3		MF, 1%, 0204, E24
0	R 79	57.60.1104	100K		MF, 1%, 0204, E24	0	R 169	57.60.1133	13K		MF, 1%, 0204, E24
0	R 80	57.60.1682	6K8		MF, 1%, 0204, E24	0	R 170	57.60.1133	13K		MF, 1%, 0204, E24
0	R 81	57.60.1821	820R		MF, 1%, 0204, E24	0	R 171	57.60.1332	3K3		MF, 1%, 0204, E24
0	R 82	57.60.1104	100K		MF, 1%, 0204, E24	0	R 172	57.60.1332	3K3		MF, 1%, 0204, E24
0	R 83	57.60.1682	6K8		MF, 1%, 0204, E24	0	R 173	57.60.1332	3K3		MF, 1%, 0204, E24
0	R 84	57.60.1153	15K		MF, 1%, 0204, E24	0	R 174	57.60.1332	3K3		MF, 1%, 0204, E24
0	R 85	57.60.1104	100K		MF, 1%, 0204, E24	0	R 175	57.60.1133	13K		MF, 1%, 0204, E24
0	R 86	57.60.1103	10K		MF, 1%, 0204, E24	0	R 176	57.11.3000	0R0		MF, 0207
0	R 87	57.60.1104	100K		MF, 1%, 0204, E24	0	R 177	57.60.1105	1M		MF, 1%, 0204, E24
0	R 88	57.60.1123	12K		MF, 1%, 0204, E24	0	R 178	57.60.1162	1K8		MF, 1%, 0204, E24
0	R 89	57.60.1133	13K		MF, 1%, 0204, E24	0	R 179	57.60.1133	13K		MF, 1%, 0204, E24
0	R 90	57.60.1332	3K3		MF, 1%, 0204, E24	0	R 180	57.60.1133	13K		MF, 1%, 0204, E24
0	R 91	57.60.1332	3K3		MF, 1%, 0204, E24	0	R 181	57.60.1133	13K		MF, 1%, 0204, E24
0	R 92	57.60.1332	3K3		MF, 1%, 0204, E24	0	R 182	57.60.1133	13K		MF, 1%, 0204, E24
0	R 93	57.60.1332	3K3		MF, 1%, 0204, E24	0	R 183	57.60.1133	13K		MF, 1%, 0204, E24
0	R 94	57.60.1133	13K		MF, 1%, 0204, E24	0	R 184	57.60.1133	13K		MF, 1%, 0204, E24
0	R 95	57.60.1133	13K		MF, 1%, 0204, E24	0	R 185	57.60.1133	13K		MF, 1%, 0204, E24
0	R 96	57.60.1332	3K3		MF, 1%, 0204, E24	0	R 186	57.60.1133	13K		MF, 1%, 0204, E24
0	R 97	57.60.1332	3K3		MF, 1%, 0204, E24	0	R 187	57.60.1133	13K		MF, 1%, 0204, E24
0	R 98	57.60.1332	3K3		MF, 1%, 0204, E24	0	R 188	57.60.1133	13K		MF, 1%, 0204, E24
0	R 99	57.60.1332	3K3		MF, 1%, 0204, E24	0	R 189	57.60.1133	13K		MF, 1%, 0204, E24
0	R 100	57.60.1133	13K		MF, 1%, 0204, E24	0	R 190	57.60.1133	13K		MF, 1%, 0204, E24
0	R 101	not used	10K		MF, 1%, 0204, E24	0	R 191	57.60.1332	3K3		MF, 1%, 0204, E24
0	R 102	57.60.1103	10K		MF, 1%, 0204, E24	0	R 192	57.60.1333	33K		MF, 1%, 0204, E24
0	R 103	57.60.1104	100K		MF, 1%, 0204, E24	0	R 193	57.60.1472	4K7		MF, 1%, 0204, E24
0	R 104	57.60.1103	10K		MF, 1%, 0204, E24	0	R 194	57.60.1472	4K7		MF, 1%, 0204, E24
0	R 105	57.60.1103	10K		MF, 1%, 0204, E24	0	R 195	57.60.1221	220R		MF, 1%, 0204, E24
0	R 106	57.60.1133	13K		MF, 1%, 0204, E24	0	R 196	57.60.1471	470R		MF, 1%, 0204, E24
0	R 107	57.60.1133	13K		MF, 1%, 0204, E24	0	R 197	57.60.1151	150R		MF, 1%, 0204, E24
0	R 108	57.60.1133	13K		MF, 1%, 0204, E24	0	R 198	57.60.1102	1K		MF, 1%, 0204, E24
0	R 109	57.60.1133	13K		MF, 1%, 0204, E24	0	R 199	57.60.1473	47K		MF, 1%, 0204, E24
0	R 110	57.60.1133	13K		MF, 1%, 0204, E24	0	R 200	57.60.1103	10K		MF, 1%, 0204, E24
0	R 111	57.60.1133	13K		MF, 1%, 0204, E24	0	R 201	57.60.1681	680R		MF, 1%, 0204, E24
0	R 112	57.60.1133	13K		MF, 1%, 0204, E24	0	R 202	57.60.1681	680R		MF, 1%, 0204, E24
0	R 113	57.60.1133	13K		MF, 1%, 0204, E24	0	R 203	57.60.1101	100R		MF, 1%, 0204, E24
0	R 114	57.60.1133	13K		MF, 1%, 0204, E24	0	R 204	57.60.1471	470R		MF, 1%, 0204, E24
0	R 115	57.60.1133	13K		MF, 1%, 0204, E24	0	R 205	57.60.1162	1K6		MF, 1%, 0204, E24
0	R 116	57.60.1133	13K		MF, 1%, 0204, E24	0	R 206	57.60.1162	1K6		MF, 1%, 0204, E24
0	R 117	57.60.1133	13K		MF, 1%, 0204, E24	0	R 207	57.60.1102	1K		MF, 1%, 0204, E24



Main Board I.660.030.22

Idx.	Pos.	Part No.	Qty.	Type/Val.	Description	Idx.	Pos.	Part No.	Qty.	Type/Val.	Description
0	R 388	57.60.1332		3K3	MF, 1%, 0204, E24	0	R 477	57.60.1223		22K	MF, 1%, 0204, E24
0	R 389	57.60.1103		10K	MF, 1%, 0204, E24	0	R 478	57.60.1222		2K2	MF, 1%, 0204, E24
0	R 390	57.60.1104		100K	MF, 1%, 0204, E24	0	R 479	57.60.1222		2K2	MF, 1%, 0204, E24
0	R 391	57.60.1332		3K3	MF, 1%, 0204, E24	0	R 480	57.60.1123		12K	MF, 1%, 0204, E24
0	R 392	57.60.1222		2K2	MF, 1%, 0204, E24	0	R 481	57.60.1123		12K	MF, 1%, 0204, E24
0	R 393	57.60.1223		22K	MF, 1%, 0204, E24	0	R 482	57.60.1222		2K2	MF, 1%, 0204, E24
0	R 394	57.60.1104		100K	MF, 1%, 0204, E24	0	R 483	57.60.1222		2K2	MF, 1%, 0204, E24
0	R 395	57.60.1104		100K	MF, 1%, 0204, E24	0	R 484	57.60.1223		22K	MF, 1%, 0204, E24
0	R 396	57.60.1223		22K	MF, 1%, 0204, E24	0	R 485	57.60.1223		22K	MF, 1%, 0204, E24
0	R 397	57.60.1222		2K2	MF, 1%, 0204, E24	0	R 486	57.60.1222		2K2	MF, 1%, 0204, E24
0	R 398	57.60.1332		3K3	MF, 1%, 0204, E24	0	R 487	57.60.1222		2K2	MF, 1%, 0204, E24
0	R 399	57.60.1332		3K3	MF, 1%, 0204, E24	0	R 488	57.60.1123		12K	MF, 1%, 0204, E24
0	R 400	57.60.1222		2K2	MF, 1%, 0204, E24	0	R 489	57.60.1123		12K	MF, 1%, 0204, E24
0	R 401	57.60.1223		22K	MF, 1%, 0204, E24	0	R 490	57.60.1222		2K2	MF, 1%, 0204, E24
0	R 402	57.60.1104		100K	MF, 1%, 0204, E24	0	R 491	57.60.1222		2K2	MF, 1%, 0204, E24
0	R 403	57.60.1104		100K	MF, 1%, 0204, E24	0	R 492	57.60.1223		22K	MF, 1%, 0204, E24
0	R 404	57.60.1223		22K	MF, 1%, 0204, E24	0	R 493	57.60.1223		22K	MF, 1%, 0204, E24
0	R 405	57.60.1222		2K2	MF, 1%, 0204, E24	0	R 494	57.60.1222		2K2	MF, 1%, 0204, E24
0	R 406	57.60.1332		3K3	MF, 1%, 0204, E24	0	R 495	57.60.1222		2K2	MF, 1%, 0204, E24
0	R 407	57.60.1332		3K3	MF, 1%, 0204, E24	0	R 496	57.60.1123		12K	MF, 1%, 0204, E24
0	R 408	57.60.1222		2K2	MF, 1%, 0204, E24	0	R 497	57.60.1332		3K3	MF, 1%, 0204, E24
0	R 409	57.60.1223		22K	MF, 1%, 0204, E24	0	R 498	57.60.1103		10K	MF, 1%, 0204, E24
0	R 410	57.60.1104		100K	MF, 1%, 0204, E24	0	R 499	57.60.1103		10K	MF, 1%, 0204, E24
0	R 411	57.60.1104		100K	MF, 1%, 0204, E24	0	R 500	57.60.1103		10K	MF, 1%, 0204, E24
0	R 412	57.60.1223		22K	MF, 1%, 0204, E24	0	R 501	57.60.1103		10K	MF, 1%, 0204, E24
0	R 413	57.60.1222		2K2	MF, 1%, 0204, E24	0	R 502	57.60.1270		27R	MF, 1%, 0204, E24
0	R 414	57.60.1332		3K3	MF, 1%, 0204, E24	0	RA 1	58.05.1501		500R	10%, 0.5W, Cermet
0	R 415	57.60.1332		3K3	MF, 1%, 0204, E24	0	RA 2	58.05.1501		500R	10%, 0.5W, Cermet
0	R 416	57.60.1222		2K2	MF, 1%, 0204, E24	0	RA 3	58.05.1501		500R	10%, 0.5W, Cermet
0	R 417	57.60.1223		22K	MF, 1%, 0204, E24	0	RA 4	58.05.1501		500R	10%, 0.5W, Cermet
0	R 418	57.60.1104		100K	MF, 1%, 0204, E24	0	RA 5	58.05.1501		500R	10%, 0.5W, Cermet
0	R 419	57.60.1104		100K	MF, 1%, 0204, E24	0	RA 6	58.05.1501		500R	10%, 0.5W, Cermet
0	R 420	57.60.1223		22K	MF, 1%, 0204, E24	0	RA 7	58.05.1501		500R	10%, 0.5W, Cermet
0	R 421	57.60.1222		2K2	MF, 1%, 0204, E24	0	RA 8	58.05.1501		500R	10%, 0.5W, Cermet
0	R 422	57.60.1332		3K3	MF, 1%, 0204, E24	0	RA 9	58.05.1103		10k	10%, 0.5W, Cermet
0	R 423	57.60.1103		10K	MF, 1%, 0204, E24	0	RA 10	58.05.1103		10k	10%, 0.5W, Cermet
0	R 424	57.60.1103		10K	MF, 1%, 0204, E24	0	RA 11	58.05.1103		10k	10%, 0.5W, Cermet
0	R 425	57.60.1103		10K	MF, 1%, 0204, E24	0	RA 12	58.05.1103		10k	10%, 0.5W, Cermet
0	R 426	57.60.1101		100R	MF, 1%, 0204, E24	0	RA 13	58.05.1103		10k	10%, 0.5W, Cermet
0	R 427	57.60.1101		100R	MF, 1%, 0204, E24	0	RA 14	58.05.1103		10k	10%, 0.5W, Cermet
0	R 428	57.60.1222		2K2	MF, 1%, 0204, E24	0	RA 15	58.05.1103		10k	10%, 0.5W, Cermet
0	R 429	57.60.1222		2K2	MF, 1%, 0204, E24	0	RA 16	58.05.1103		10k	10%, 0.5W, Cermet
0	R 430	57.60.1222		2K2	MF, 1%, 0204, E24	0	RA 17	58.20.6101		10K lin	1*R, lin,
0	R 431	57.60.1222		2K2	MF, 1%, 0204, E24	0	RA 18	58.20.6101		10K lin	1*R, lin,
0	R 432	57.60.1222		2K2	MF, 1%, 0204, E24	0	RA 19	58.20.6101		10K lin	1*R, lin,
0	R 433	57.60.1222		2K2	MF, 1%, 0204, E24	0	RA 20	58.20.6101		10K lin	1*R, lin,
0	R 434	57.60.1222		2K2	MF, 1%, 0204, E24	0	RA 21	58.20.6101		10K lin	1*R, lin,
0	R 435	57.60.1222		2K2	MF, 1%, 0204, E24	0	RA 22	58.20.6101		10K lin	1*R, lin,
0	R 436	57.60.1103		10K	MF, 1%, 0204, E24	0	RA 23	58.20.6101		10K lin	1*R, lin,
0	R 437	57.60.1103		10K	MF, 1%, 0204, E24	0	RA 24	58.20.6101		10K lin	1*R, lin,
0	R 438	57.60.1123		12K	MF, 1%, 0204, E24	0	RA 25	58.20.6202		2*10K lin	R 2*10K, lin,
0	R 439	57.60.1153		15K	MF, 1%, 0204, E24	0	RZ 1	57.88.4473		8*47k	2%, S1P 9
0	R 440	57.60.1153		15K	MF, 1%, 0204, E24	0	RZ 2	57.88.4473		8*47k	2%, S1P 9
0	R 441	57.60.1153		15K	MF, 1%, 0204, E24	0	RZ 3	57.88.4473		8*47k	2%, S1P 9
0	R 442	57.60.1153		15K	MF, 1%, 0204, E24	0	S 1	55.15.0138		1*A	S 1 TASTE, 1*A,IMPULS,1.0 N
0	R 443	57.60.1123		12K	MF, 1%, 0204, E24	0	T 1	1.022.647.00		1:1.4	OUTPUT TRAFO AES/EBU
0	R 444	57.60.1123		12K	MF, 1%, 0204, E24	0	T 2	1.022.647.00		1:1.4	OUTPUT TRAFO AES/EBU
0	R 445	57.60.1153		15K	MF, 1%, 0204, E24	0	T 3	1.022.647.00		1:1.4	OUTPUT TRAFO AES/EBU
0	R 446	57.60.1153		15K	MF, 1%, 0204, E24	0	T 4	1.022.647.00		1:1.4	OUTPUT TRAFO AES/EBU
0	R 447	57.60.1153		15K	MF, 1%, 0204, E24	0	T 5	1.022.368.00			Line Output Trafo 6 dB
0	R 448	57.60.1153		15K	MF, 1%, 0204, E24	0	T 6	1.022.368.00			Line Output Trafo 6 dB
0	R 449	57.60.1123		12K	MF, 1%, 0204, E24	0	T 7	1.022.368.00			Line Output Trafo 6 dB
0	R 450	57.60.1123		12K	MF, 1%, 0204, E24	0	T 8	1.022.368.00			Line Output Trafo 6 dB
0	R 451	57.60.1153		15K	MF, 1%, 0204, E24	0	T 9	1.022.368.00			Line Output Trafo 6 dB
0	R 452	57.60.1153		15K	MF, 1%, 0204, E24	0	T 10	1.022.368.00			Line Output Trafo 6 dB
0	R 453	57.60.1153		15K	MF, 1%, 0204, E24	0	T 11	1.022.368.00			Line Output Trafo 6 dB
0	R 454	57.60.1153		15K	MF, 1%, 0204, E24	0	T 12	1.022.368.00			Line Output Trafo 6 dB
0	R 455	57.60.1123		12K	MF, 1%, 0204, E24	0	XIC 7	53.03.2244		PLCC44p	PLCC-Socket 44p
0	R 456	57.60.1123		12K	MF, 1%, 0204, E24	0	XIC 25	53.03.2244		PLCC44p	PLCC-Socket 44p
0	R 457	57.60.1153		15K	MF, 1%, 0204, E24	0	XIC 54	53.03.0166		8p	DIL 0.3", lot, gerade
0	R 458	57.60.1153		15K	MF, 1%, 0204, E24	0	XIC 55	53.03.0165		20p	DIL 0.3", lot, gerade
0	R 459	57.60.1153		15K	MF, 1%, 0204, E24	0	XIC 56	53.03.0166		8p	DIL 0.3", lot, gerade
0	R 460	57.60.1153		15K	MF, 1%, 0204, E24	0	XIC 86	53.03.0166		8p	DIL 0.3", lot, gerade
0	R 461	57.60.1123		12K	MF, 1%, 0204, E24	0	XIC 87	53.03.0166		8p	DIL 0.3", lot, gerade
0	R 462	57.60.1103		10K	MF, 1%, 0204, E24	0	XY 1	89.01.1499			QUARZ - ISOLIERPLATTE
0	R 463	57.60.1103		10K	MF, 1%, 0204, E24	0	XY 2	89.01.1499			QUARZ - ISOLIERPLATTE
0	R 464	57.60.1104		100K	MF, 1%, 0204, E24	0	Y 1	89.01.1009		16.000MHz	Y 16.000 MHZ, HC 49/U
0	R 465	57.60.1123		12K	MF, 1%, 0204, E24	0	Y 2	89.01.1013		12.500MHz	Y 12.500 MHZ, HC 49/U
0	R 466	57.60.1222		2K2	MF, 1%, 0204, E24						
0	R 467	57.60.1222		2K2	MF, 1%, 0204, E24						
0	R 468	57.60.1223		22K	MF, 1%, 0204, E24						
0	R 469	57.60.1223		22K	MF, 1%, 0204, E24						
0	R 470	57.60.1222		2K2	MF, 1%, 0204, E24						
0	R 471	57.60.1222		2K2	MF, 1%, 0204, E24						
0	R 472	57.60.1123		12K	MF, 1%, 0204, E24						
0	R 473	57.60.1123		12K	MF, 1%, 0204, E24						
0	R 474	57.60.1222		2K2	MF, 1%, 0204, E24						
0	R 475	57.60.1222		2K2	MF, 1%, 0204, E24						
0	R 476	57.60.1223		22K	MF, 1%, 0204, E24						

End of List
Comments:

Keyboard 1.660.040.00

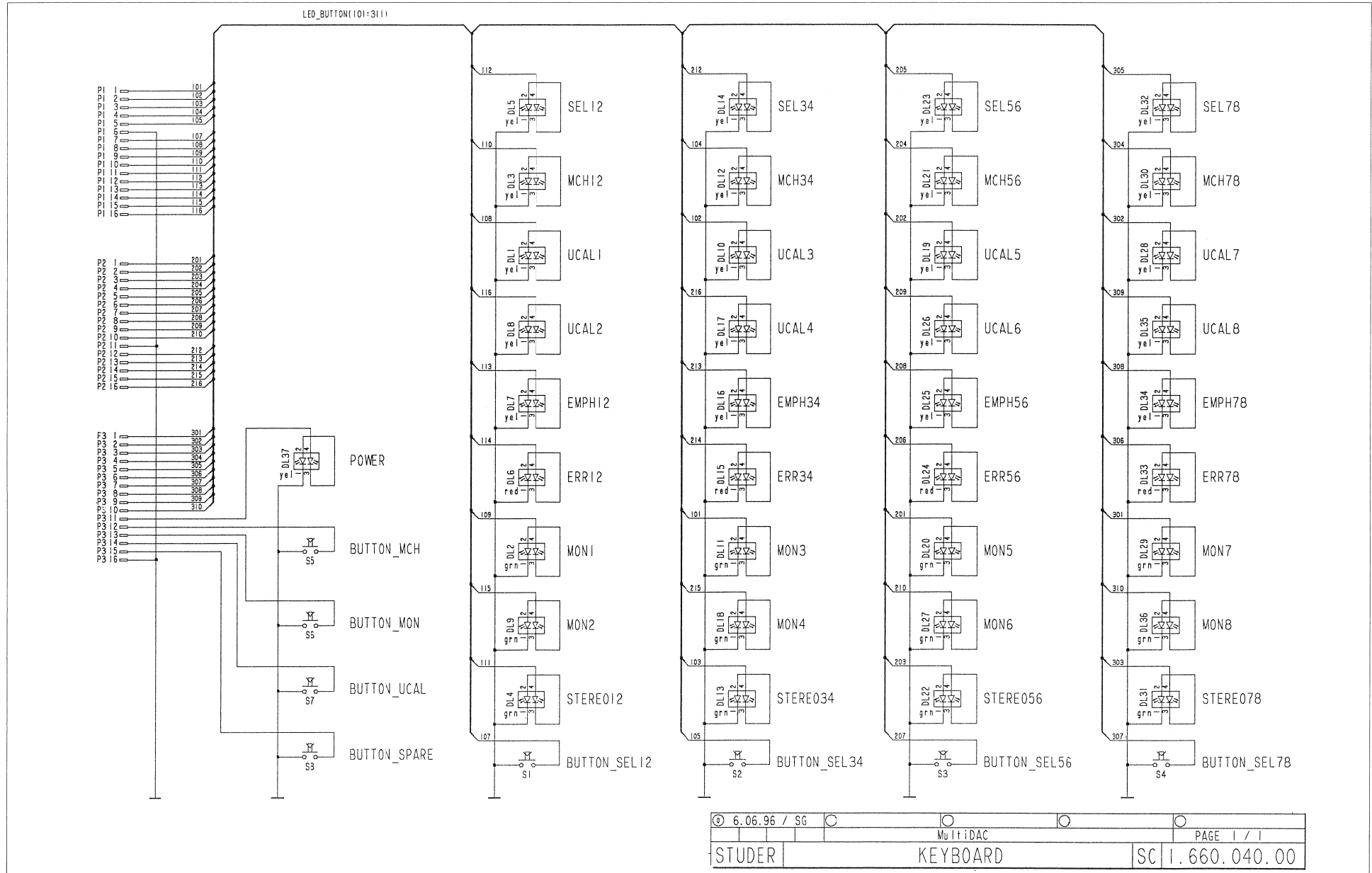

Keyboard 1.660.040.00

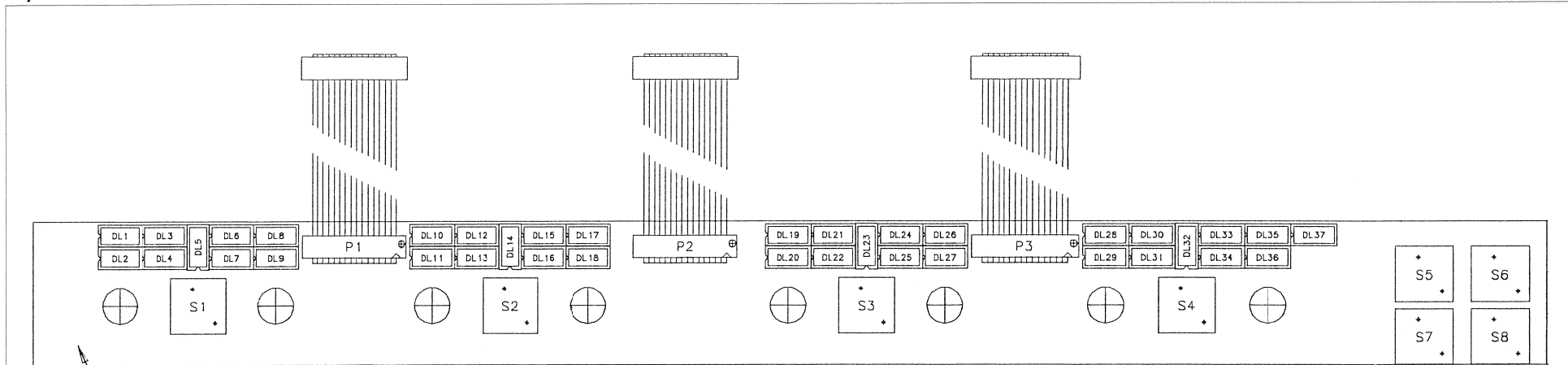

MP 1

Idx. Pos.	Part No.	Qty.	Type/Val.	Description	Idx. Pos.	Part No.	Qty.	Type/Val.	Description		
0	DL 1	50.04.2804	YEL	DLZ HLMP-2400	2'D GB	0	MP 1	1.660.040.11	1 pce	KEY BOARD 8CH.PCB	/A
0	DL 2	50.04.2803	GRN	DLZ HLMP-2500	2'D GN	0	MP 2	not used	1 pce	Label	ESE-WARNSCHILD
0	DL 3	50.04.2804	YEL	DLZ HLMP-2400	2'D GB	0	MP 3	1.660.040.10	1 pce		NR-ETIKETTE 5 X 20
0	DL 4	50.04.2803	GRN	DLZ HLMP-2500	2'D GN	0	P 1	1.023.595.05	Ribkn16p	FLACHKABEL	16 POL. 0,15M
0	DL 5	50.04.2804	YEL	DLZ HLMP-2400	2'D GB	0	P 2	1.023.595.05	Ribkn16p	FLACHKABEL	16 POL. 0,15M
0	DL 6	50.04.2805	RED	DLZ HLMP-2300	2'D RT	0	P 3	1.023.595.05	Ribkn16p	FLACHKABEL	16 POL. 0,15M
0	DL 7	50.04.2804	YEL	DLZ HLMP-2400	2'D GB	0	S 1	55.99.0158	1*a	S	IMPULS - DRUCKTASTENSCH.
0	DL 8	50.04.2804	YEL	DLZ HLMP-2400	2'D GB	0	S 2	55.99.0158	1*a	S	IMPULS - DRUCKTASTENSCH.
0	DL 9	50.04.2803	GRN	DLZ HLMP-2500	2'D GN	0	S 3	55.99.0158	1*a	S	IMPULS - DRUCKTASTENSCH.
0	DL 10	50.04.2804	YEL	DLZ HLMP-2400	2'D GB	0	S 4	55.99.0158	1*a	S	IMPULS - DRUCKTASTENSCH.
0	DL 11	50.04.2803	GRN	DLZ HLMP-2500	2'D GN	0	S 5	55.99.0158	1*a	S	IMPULS - DRUCKTASTENSCH.
0	DL 12	50.04.2804	YEL	DLZ HLMP-2400	2'D GB	0	S 6	55.99.0158	1*a	S	IMPULS - DRUCKTASTENSCH.
0	DL 13	50.04.2803	GRN	DLZ HLMP-2500	2'D GN	0	S 7	55.99.0158	1*a	S	IMPULS - DRUCKTASTENSCH.
0	DL 14	50.04.2804	YEL	DLZ HLMP-2400	2'D GB	0	S 8	not used	1*a	S	IMPULS - DRUCKTASTENSCH.
0	DL 15	50.04.2805	RED	DLZ HLMP-2300	2'D RT	End of List					
0	DL 16	50.04.2804	YEL	DLZ HLMP-2400	2'D GB	Comments					
0	DL 17	50.04.2804	YEL	DLZ HLMP-2400	2'D GB						
0	DL 18	50.04.2803	GRN	DLZ HLMP-2500	2'D GN						
0	DL 19	50.04.2804	YEL	DLZ HLMP-2400	2'D GB						
0	DL 20	50.04.2803	GRN	DLZ HLMP-2500	2'D GN						
0	DL 21	50.04.2804	YEL	DLZ HLMP-2400	2'D GB						
0	DL 22	50.04.2803	GRN	DLZ HLMP-2500	2'D GN						
0	DL 23	50.04.2804	YEL	DLZ HLMP-2400	2'D GB						
0	DL 24	50.04.2805	RED	DLZ HLMP-2300	2'D RT						
0	DL 25	50.04.2804	YEL	DLZ HLMP-2400	2'D GB						
0	DL 26	50.04.2804	YEL	DLZ HLMP-2400	2'D GB						
0	DL 27	50.04.2803	GRN	DLZ HLMP-2500	2'D GN						
0	DL 28	50.04.2804	YEL	DLZ HLMP-2400	2'D GB						
0	DL 29	50.04.2803	GRN	DLZ HLMP-2500	2'D GN						
0	DL 30	50.04.2804	YEL	DLZ HLMP-2400	2'D GB						
0	DL 31	50.04.2803	GRN	DLZ HLMP-2500	2'D GN						
0	DL 32	50.04.2804	YEL	DLZ HLMP-2400	2'D GB						
0	DL 33	50.04.2805	RED	DLZ HLMP-2300	2'D RT						
0	DL 34	50.04.2804	YEL	DLZ HLMP-2400	2'D GB						
0	DL 35	50.04.2804	YEL	DLZ HLMP-2400	2'D GB						
0	DL 36	50.04.2803	GRN	DLZ HLMP-2500	2'D GN						
0	DL 37	50.04.2804	YEL	DLZ HLMP-2400	2'D GB						

Erstellt	06.06.96	PZ					
Datum							
Gepr. von							
Gepr. Tag							
Index							

STUDER REGENSDORF
KEYBOARD
 Number: 1.660.040.00

ADAT Input Module 1.660.050.20
LDP Receiver Module 1.660.059.20

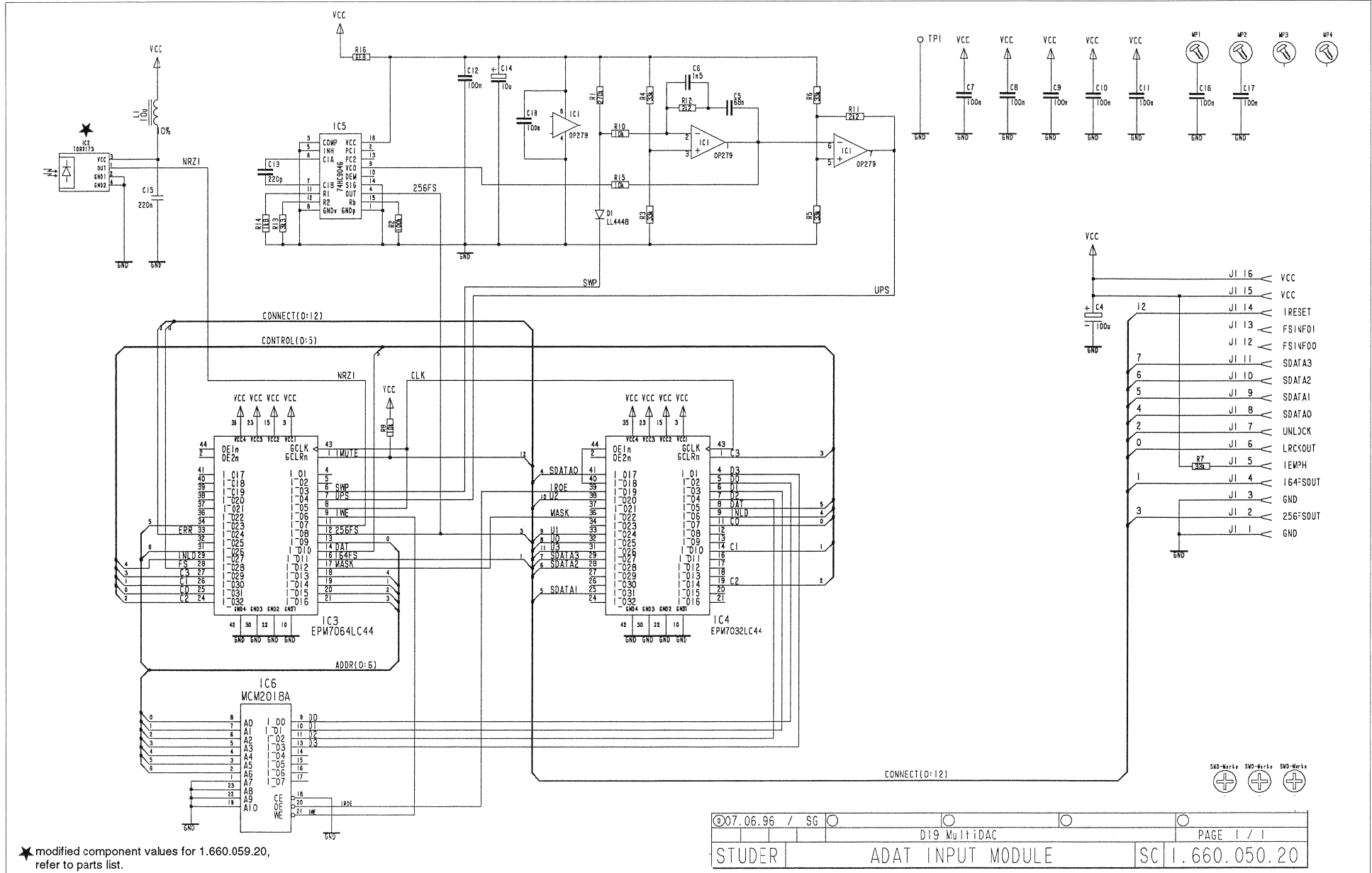

* modified component values for 1.660.059.20, refer to parts list.



ADAT Input Module 1.660.050.20
LDP Receiver Module 1.660.059.20

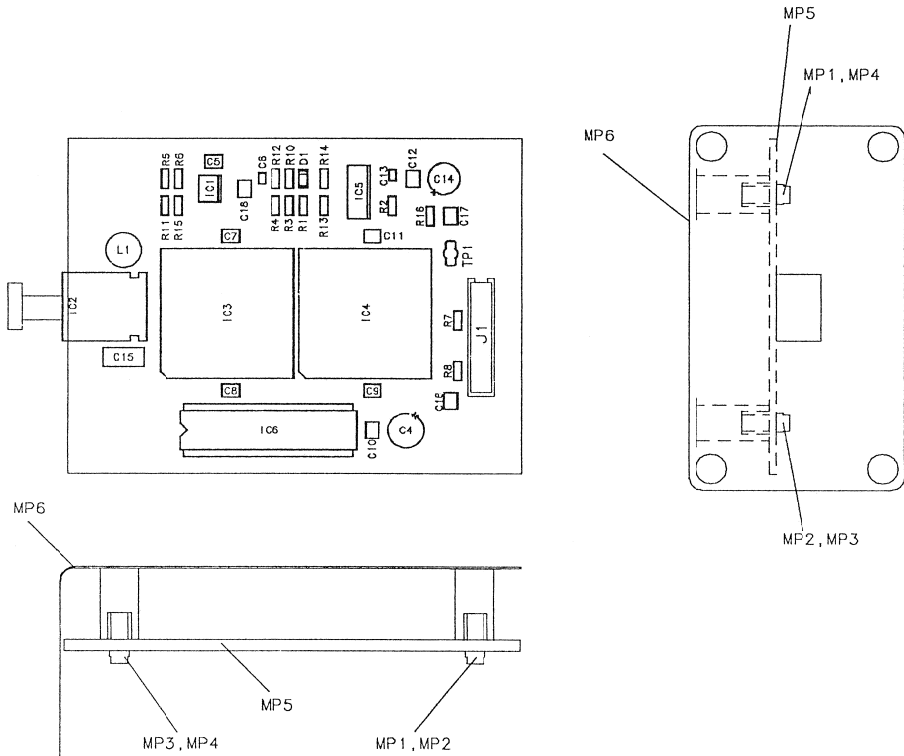

Parts List 1.660.050.20

Idx. Pos.	Part No.	Qty.	Type/Val.	Description
0	C 4	59.22.3101	100u	EL 10V, 20%, rad RM5
0	C 5	59.60.1683	68n	CER 10%, X7R, 1210
0	C 6	59.60.1152	1n5	CER 10%, X7R, 0805
0	C 7	59.60.1104	100n	CER 10%, X7R, 1210
0	C 8	59.60.1104	100n	CER 10%, X7R, 1210
0	C 9	59.60.1104	100n	CER 10%, X7R, 1210
0	C 10	59.60.1104	100n	CER 10%, X7R, 1210
0	C 11	59.60.1104	100n	CER 10%, X7R, 1210
0	C 12	59.60.1104	100n	CER 10%, X7R, 1210
0	C 13	59.60.0221	220p	CER 5%, COG, 0805
0	C 14	59.22.6100	10u	EL 35V, 20%, rad RM5
0	C 15	59.06.0224	220n	PETP, 10%, 63V
0	C 16	59.60.1104	100n	CER 10%, X7R, 1210
0	C 17	59.60.1104	100n	CER 10%, X7R, 1210
0	C 18	59.60.1104	100n	CER 10%, X7R, 1210
0	D 1	50.60.8001	4448	D LL 4448 SOD 80
0	IC 1	50.61.0203	OP279	Dual Op-Amp
0	IC 2	89.10.0131	TORX173	Toslink Receiver
0	IC 3	1.660.051.20		SW 050.XX (IC3,7064,50634202)
0	IC 4	1.660.053.20		SW 050.XX (IC4,7032,50634201)
0	IC 5	50.62.4946	74HCT9046	IC - 74 HCT 9046 . A
0	IC 6	50.14.1009	CY7C128-35	IC MCM 2018 A - 35 .A
0	J 1	54.14.5516	16-P	J PCB-BUCHSE GERADE 16 P
0	L 1	62.02.3100	10uH	L 10 U , 10%, RAD , RM 5
0	MP 1	21.53.9354	pce	Z - SCHR.IS, M.SICH, M 3 * 6
0	MP 2	21.53.9354	pce	Z - SCHR.IS, M.SICH, M 3 * 6
0	MP 3	21.53.9354	pce	Z - SCHR.IS, M.SICH, M 3 * 6
0	MP 4	21.53.9354	pce	Z - SCHR.IS, M.SICH, M 3 * 6
0	MP 5	1.660.050.11	1 pce	ADAT INPUT MODULE,PCB /I/
0	MP 6	1.660.050.01	1 pce	EINSCHUBTRAEGER,OPTICAL IN
0	MP 7	43.01.0108	1 pce	ESE-WARNSCHILD
0	MP 8	1.101.001.20	1 pce	TEXT-ETIK. 5*20 HARDWARE -20
0	MP 9	1.660.050.10	1 pce	NR-ETIKETTE 5 X 20
0	R 1	57.60.1274	270K	MF, 1%, 0204, E24
0	R 2	57.60.1104	100K	MF, 1%, 0204, E24
0	R 3	57.60.1333	33K	MF, 1%, 0204, E24
0	R 4	57.60.1333	33K	MF, 1%, 0204, E24
0	R 5	57.60.1333	33K	MF, 1%, 0204, E24
0	R 6	57.60.1333	33K	MF, 1%, 0204, E24
0	R 7	57.60.1333	33K	MF, 1%, 0204, E24
0	R 8	57.60.1103	10K	MF, 1%, 0204, E24
0	R 9	57.60.1103	10K	MF, 1%, 0204, E24
0	R 10	57.60.1103	10K	MF, 1%, 0204, E24
0	R 11	57.60.1222	2K2	MF, 1%, 0204, E24
0	R 12	57.60.1222	2K2	MF, 1%, 0204, E24
0	R 13	57.60.1332	3K3	MF, 1%, 0204, E24
0	R 14	57.60.1182	1K8	MF, 1%, 0204, E24
0	R 15	57.60.1103	10K	MF, 1%, 0204, E24
0	R 16	57.60.1699	6R8	MF, 2%, 0204, E24
0	TP 1	54.02.0320	1p	Flatpin, 2.8*0.8mm
0	XIC 3	53.03.2244	XIC PLCC44	XIC PLCC 44 PIN
0	XIC 4	53.03.2244	XIC PLCC44	XIC PLCC 44 PIN

Comments

End of List

Parts List 1.660.059.20

Idx. Pos.	Part No.	Qty.	Type/Val.	Description
0	C 4	59.22.3101	100u	EL 10V, 20%, RM5
0	C 5	59.60.1683	68n	CER 63V, 10%, X7R, 1210
0	C 6	59.60.1152	1n5	CER 63V, 10%, X7R, 0805
0	C 7	59.60.1104	100n	CER 63V, 10%, X7R, 1210
0	C 8	59.60.1104	100n	CER 63V, 10%, X7R, 1210
0	C 9	59.60.1104	100n	CER 63V, 10%, X7R, 1210
0	C 10	59.60.1104	100n	CER 63V, 10%, X7R, 1210
0	C 11	59.60.1104	100n	CER 63V, 10%, X7R, 1210
0	C 12	59.60.1104	100n	CER 63V, 10%, X7R, 1210
0	C 13	59.60.0221	220p	CER 63V, 5%, COG, 0805
0	C 14	59.22.6100	10u	EL 35V, 20%, RM5
0	C 15	59.06.0224	220n	PETP, 63V, 10%, RM5
0	C 16	59.60.1104	100n	CER 63V, 10%, X7R, 1210
0	C 17	59.60.1104	100n	CER 63V, 10%, X7R, 1210
0	C 18	59.60.1104	100n	CER 63V, 10%, X7R, 1210
0	D 1	50.60.8001	4448	D LL 4448 SOD 80
0	IC 1	50.61.0203	OP279	Dual Op-Amp
0	IC 2	89.10.0131	TORX194	Toslink Receiver
0	IC 3	1.660.051.20		SW 050.XX (IC3,7064,50634202)
0	IC 4	1.660.053.20		SW 050.XX (IC4,7032,50634201)
0	IC 5	50.62.4946	74HCT9046	IC - 74 HCT 9046 . A
0	IC 6	50.14.1009	CY7C128-35	IC MCM 2018 A - 35 .A
0	J 1	54.14.5516	16p	J PCB-BUCHSE GERADE 16 P
0	L 1	62.02.3100	10uH	L 10 U , 10%, RAD , RM 5
0	MP 1	21.53.9354	mp	Z - SCHR.IS, M.SICH, M 3 * 6
0	MP 2	21.53.9354	mp	Z - SCHR.IS, M.SICH, M 3 * 6
0	MP 3	21.53.9354	mp	Z - SCHR.IS, M.SICH, M 3 * 6
0	MP 4	21.53.9354	mp	Z - SCHR.IS, M.SICH, M 3 * 6
0	MP 5	1.660.050.11	1 pce	ADAT INPUT MODULE,PCB /I/
0	MP 6	1.660.059.01	1 pce	EINSCHUBTRAEGER,OPT IN, LDP
0	MP 7	43.01.0108	1 pce	ESE-WARNSCHILD
0	MP 8	1.101.001.20	1 pce	TEXT-ETIK. 5*20 HARDWARE -20
0	MP 9	1.660.059.10	1 pce	NR-ETIKETTE 5 X 20
0	R 1	57.60.1274	270K	MF, 1%, 0204, E24
0	R 2	57.60.1104	100K	MF, 1%, 0204, E24
0	R 3	57.60.1333	33K	MF, 1%, 0204, E24
0	R 4	57.60.1333	33K	MF, 1%, 0204, E24
0	R 5	57.60.1333	33K	MF, 1%, 0204, E24
0	R 6	57.60.1333	33K	MF, 1%, 0204, E24
0	R 7	57.60.1333	33K	MF, 1%, 0204, E24
0	R 8	57.60.1103	10K	MF, 1%, 0204, E24
0	R 9	57.60.1103	10K	MF, 1%, 0204, E24
0	R 10	57.60.1222	2K2	MF, 1%, 0204, E24
0	R 11	57.60.1222	2K2	MF, 1%, 0204, E24
0	R 12	57.60.1332	3K3	MF, 1%, 0204, E24
0	R 13	57.60.1182	1K8	MF, 1%, 0204, E24
0	R 14	57.60.1103	10K	MF, 1%, 0204, E24
0	R 15	57.60.1103	10K	MF, 1%, 0204, E24
0	R 16	57.60.1699	6R8	MF, 2%, 0204, E24
0	TP 1	54.02.0320	1p	Flatpin, 2.8*0.8mm
0	XIC 3	53.03.2244	PLCC44p	PLCC-Socket 44p
0	XIC 4	53.03.2244	PLCC44p	PLCC-Socket 44p

End of List

Comments:

Revision	Modifikation	Ursprung	Änderung	Ursprung	Änderung	Ursprung	Änderung	Ursprung	Änderung
07.06.96	SG								
Author	Size	Verf.	Gene.	Rev.	Index				
Copy to:									
Issue Form:									

STUDER
 REGENSORF
 Description: ADAT INPUT MODULE "ESE"
 Number: 1.660.050.20



TDIF-I Input Module 1.660.052.21

25pin female
C-Sub Connector
(from DA-88)

16pin uMatch
Connector
(from Main Board)

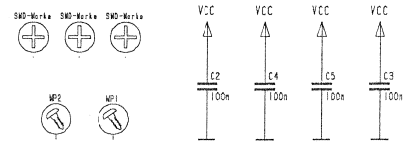
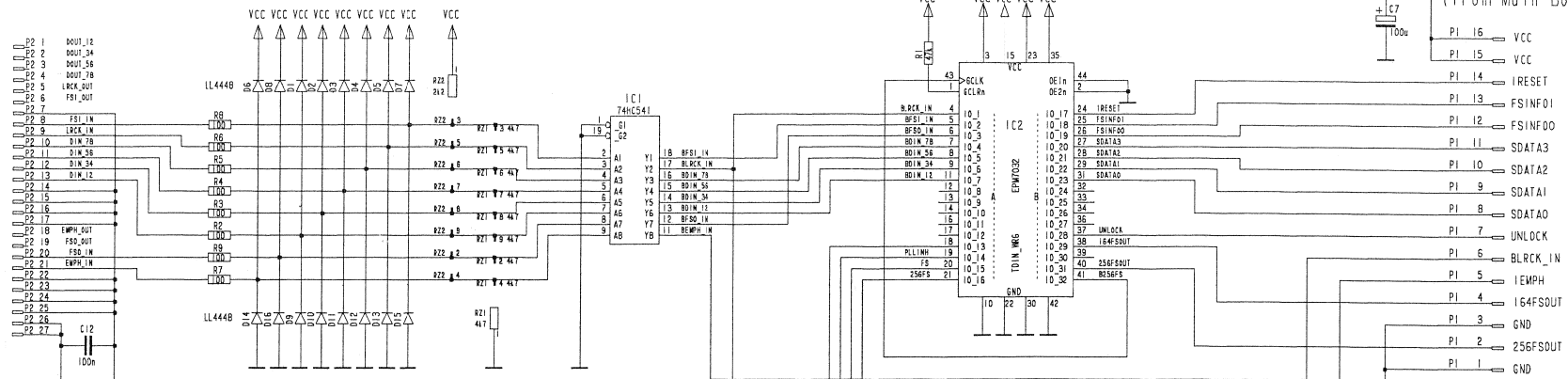

©28.07.97 / SG		MultiDAC		PAGE 1 / 1	
STUDER	TDIF-I INPUT MODULE	SC	1.660.052.21		



TDIF-I Input Module 1.660.052.21

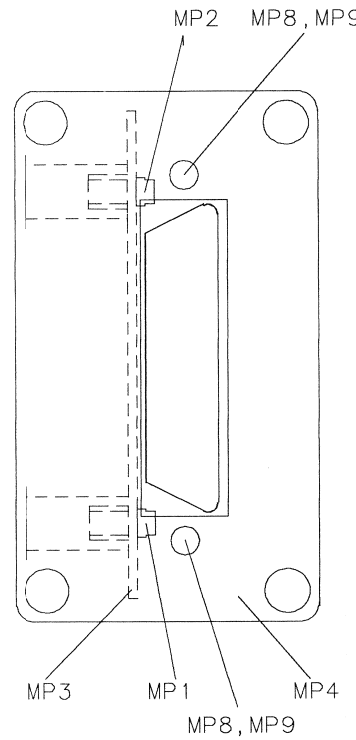
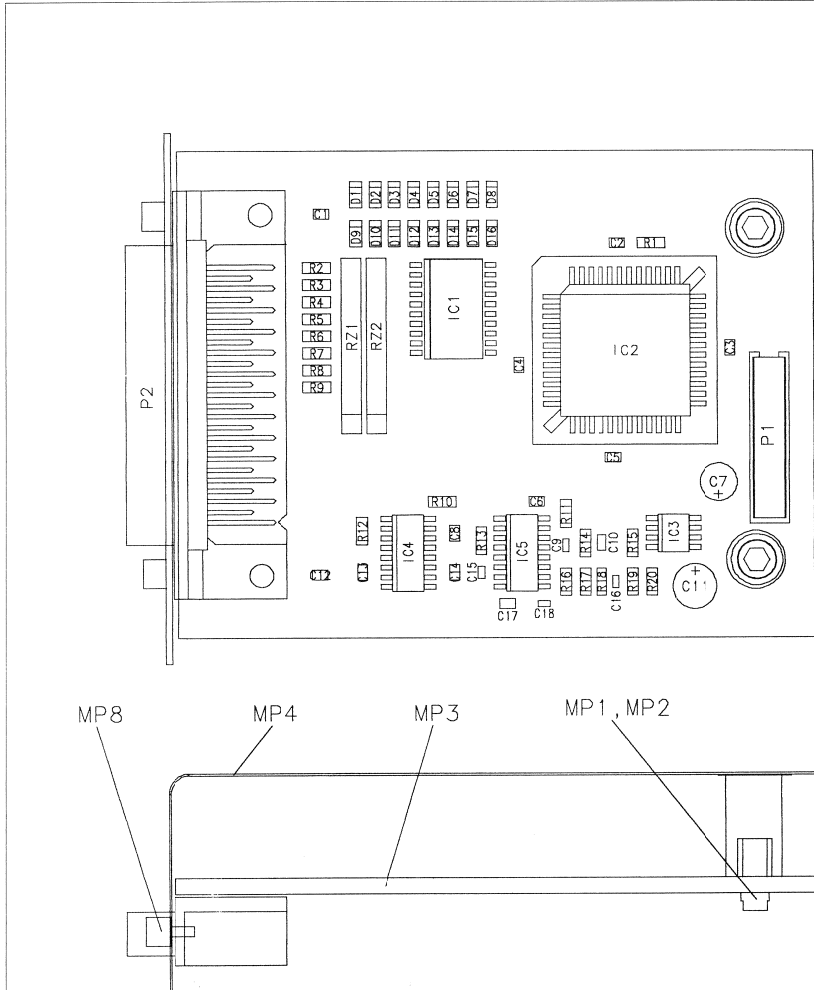

Idx.	Pos.	Part No.	Qty.	Type/Val.	Description
0	C 1	59.60.3337	100n		CER 50V, 10%, X7R, 0805
0	C 2	59.60.3337	100n		CER 50V, 10%, X7R, 0805
0	C 3	59.60.3337	100n		CER 50V, 10%, X7R, 0805
0	C 4	59.60.3337	100n		CER 50V, 10%, X7R, 0805
0	C 5	59.60.3337	100n		CER 50V, 10%, X7R, 0805
0	C 6	59.60.3337	100n		CER 50V, 10%, X7R, 0805
0	C 7	59.22.4002	100uF		EL 16V, 20%, RM5
0	C 8	59.60.3337	100n		CER 50V, 10%, X7R, 0805
0	C 9	59.60.2237	33p		CER 50V, 5%, COG, 0603
0	C 10	59.60.3337	100n		CER 50V, 10%, X7R, 0805
0	C 11	59.22.6100	10u		EL 35V, 20%, RM5
0	C 12	59.60.3337	100n		CER 50V, 10%, X7R, 0805
0	C 13	59.60.3337	100n		CER 50V, 10%, X7R, 0805
0	C 14	59.60.3321	4n7		CER 50V, 10%, X7R, 0605
0	C 15	59.60.2243	95p		CER 50V, 5%, COG, 0603
0	C 16	59.60.2237	33p		CER 50V, 5%, COG, 0603
0	C 17	59.60.3337	100n		CER 50V, 10%, X7R, 0805
0	C 18	59.60.2257	220p		CER 50V, 5%, COG, 0603
0	D 1	50.60.8001	4448		D LL 4448 SOD 80
0	D 2	50.60.8001	4448		D LL 4448 SOD 80
0	D 3	50.60.8001	4448		D LL 4448 SOD 80
0	D 4	50.60.8001	4448		D LL 4448 SOD 80
0	D 5	50.60.8001	4448		D LL 4448 SOD 80
0	D 6	50.60.8001	4448		D LL 4448 SOD 80
0	D 7	50.60.8001	4448		D LL 4448 SOD 80
0	D 8	50.60.8001	4448		D LL 4448 SOD 80
0	D 9	50.60.8001	4448		D LL 4448 SOD 80
0	D 10	50.60.8001	4448		D LL 4448 SOD 80
0	D 11	50.60.8001	4448		D LL 4448 SOD 80
0	D 12	50.60.8001	4448		D LL 4448 SOD 80
0	D 13	50.60.8001	4448		D LL 4448 SOD 80
0	D 14	50.60.8001	4448		D LL 4448 SOD 80
0	D 15	50.60.8001	4448		D LL 4448 SOD 80
0	D 16	50.60.8001	4448		D LL 4448 SOD 80
0	IC 1	50.62.1541		74HC841	74 HC 541
0	IC 2	1.660.054.20		SW 052.XX	(EPLD)7032, 50694201)
0	IC 3	50.61.0202		LM359	IC LM 358 D A
0	IC 4	50.62.1423		74HC423	74 HC 423
0	IC 5	50.62.4946		74HCT9046	IC ..74 HCT 9046. A
0	MP 1	21.53.9354	1 pce	M3*6	Z-Schraube Inbus-Ripp Zn gb ch
0	MP 2	21.53.9354	1 pce	M3*6	Z-Schraube Inbus-Ripp Zn gb ch
0	MP 3	1.660.052.11	1 pce		TDIF-I INPUT MODULE PCB /A
0	MP 4	1.660.052.01	1 pce		EINSCHUBTRAEGER, TDIF-1 INPUT
0	MP 5	43.01.0108	1 pce	Label	ESE-WARNSCHILD
0	MP 6	1.101.001.20	1 pce	Label	TEXT-ETIK: P*20 HARDWARE -20
0	MP 7	1.660.052.10	1 pce	Label	NR-ETIKETTE 5 X 20
0	MP 8	1.650.052.02	2 pcs		VERRIEGELUNGSBOLZEN
0	MP 9	24.16.2030	2 pcs		FAECHERSCHEIBE A D 3.2
0	P 1	54.14.5916	16p		J PCB-BUCHSE GERADE 16 P
0	P 2	54.13.0073	25p		D-Sub, PCB, Winkel
0	R 1	57.60.1473	47K		MF, 1%, 0204, E24
0	R 2	57.60.1101	100R		MF, 1%, 0204, E24
0	R 3	57.60.1101	100R		MF, 1%, 0204, E24
0	R 4	57.60.1101	100R		MF, 1%, 0204, E24
0	R 5	57.60.1101	100R		MF, 1%, 0204, E24
0	R 6	57.60.1101	100R		MF, 1%, 0204, E24
0	R 7	57.60.1101	100R		MF, 1%, 0204, E24
0	R 8	57.60.1101	100R		MF, 1%, 0204, E24
0	R 9	57.60.1101	100R		MF, 1%, 0204, E24
0	R 10	57.60.1104	100K		MF, 1%, 0204, E24
0	R 11	57.60.1473	47K		MF, 1%, 0204, E24
0	R 12	57.60.1104	100K		MF, 1%, 0204, E24
0	R 13	57.60.1472	4K7		MF, 1%, 0204, E24
0	R 14	57.60.1102	1K		MF, 1%, 0204, E24
0	R 15	57.60.1103	10K		MF, 1%, 0204, E24
0	R 16	57.60.1562	5K6		MF, 1%, 0204, E24
0	R 17	57.60.1153	15K		MF, 1%, 0204, E24
0	R 18	57.60.1562	5K6		MF, 1%, 0204, E24
0	R 19	57.60.1103	10K		MF, 1%, 0204, E24
0	R 20	57.60.1102	1K		MF, 1%, 0204, E24
0	RZ 1	57.88.4472	8*4K7		2%, SIP 9
0	RZ 2	57.88.4222	8*2K2		2%, SIP 9
0	XIC 2	53.03.2244	PLCC44p		PLCC-Socket 44p

Comments:
...Z1: C18 = 220pF for PLL stability

STUDER	REGENDSORF	TDIF-I INPUT MODULE "ESE"	1.660.052-21
--------	------------	---------------------------	--------------

Revision	28.07.97	PZ							
U. Datum	28.07.97	PZ							
Gez.									
Viso									
Gez.									
Dep.									
Kopie									
Fuer									