

UKAWINU NU, SIMINUU'LI'Z
JULY '82 ISS. 1
DESIGN KAYLWARD. B.S.C.

MOSFET

1000

VIA TRANSFORMER
(SEE ATTACHED DRAWING)

INPUT ATTENUATOR

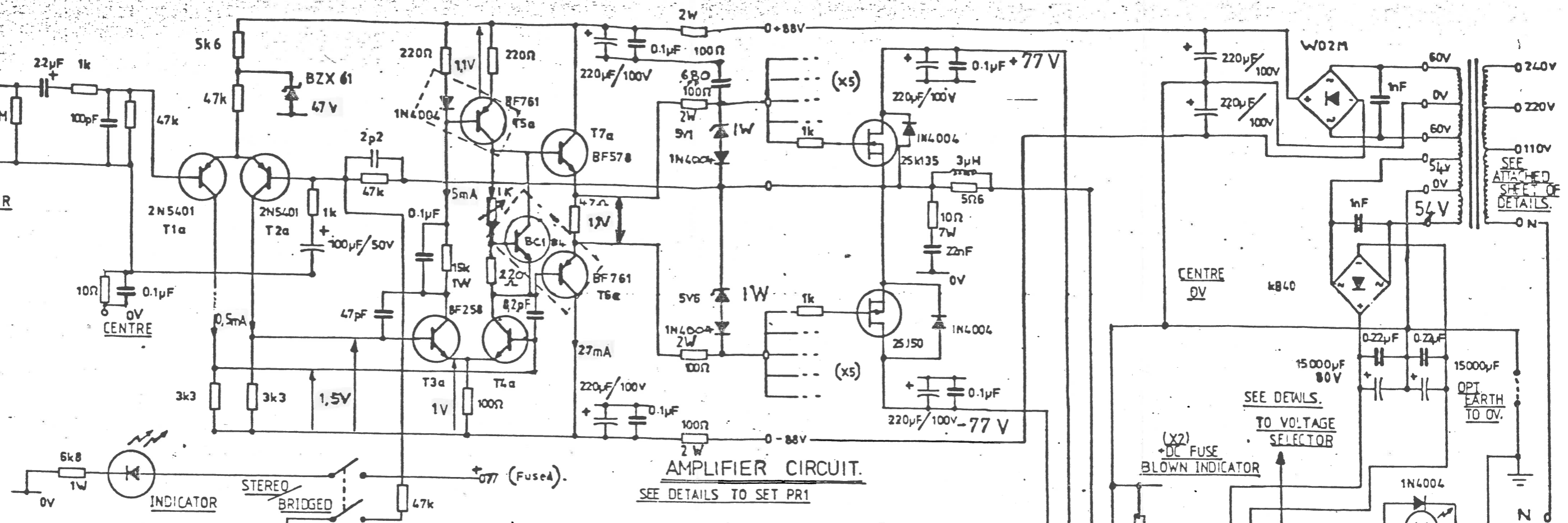

D.C. CUT-OUT
DETECTS ±3.5V
MINIMUM ON
OUTPUT.

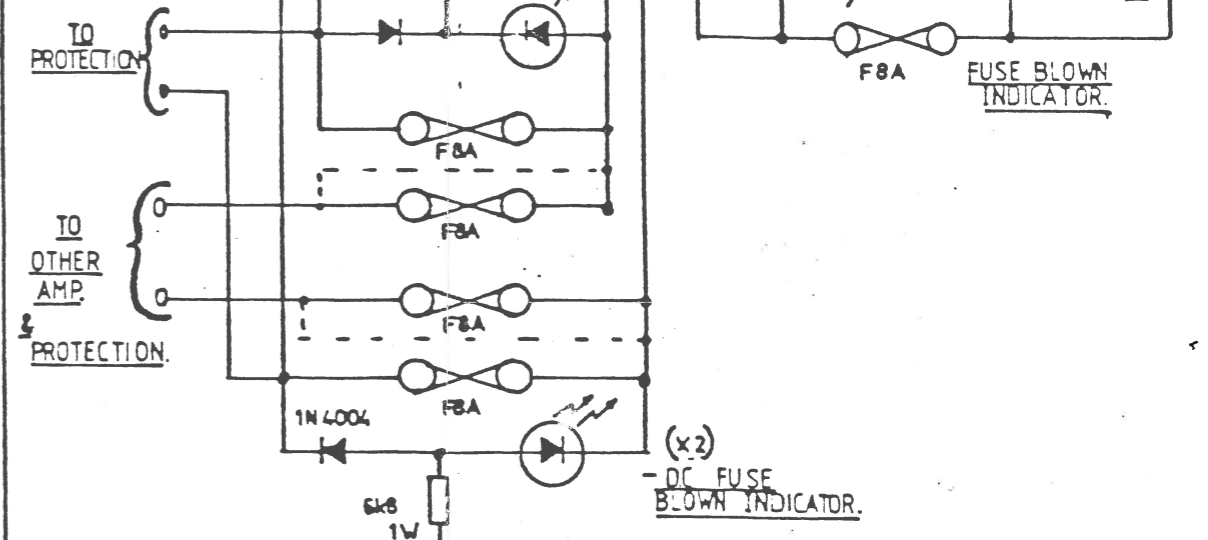
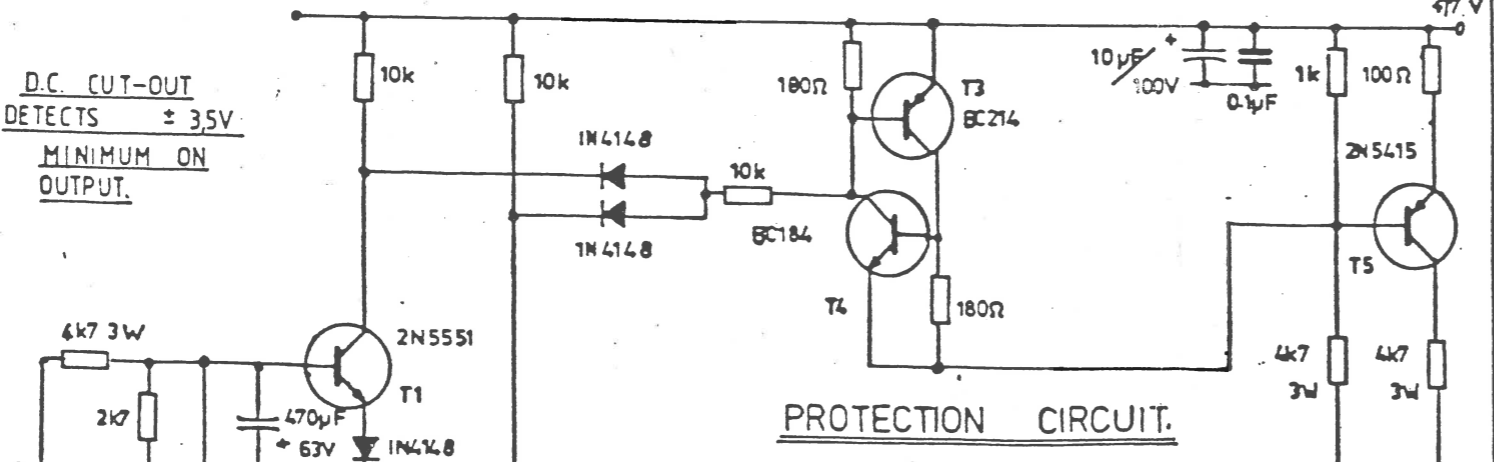

SPEAKER CONNECTOR.

TO BARGRAPH DISPLAY.
(SEE ATTACHED DRAWING)

SEE ATTACHED SHEET OF DETAILS.

SEE DETAILS TO VOLTAGE SELECTOR

(X2) DC FUSE BLOWN INDICATOR.

DRAWING No. SM-1000-C2-1
 JULY '82 ISS 1 I.W.

MOSFET

1000

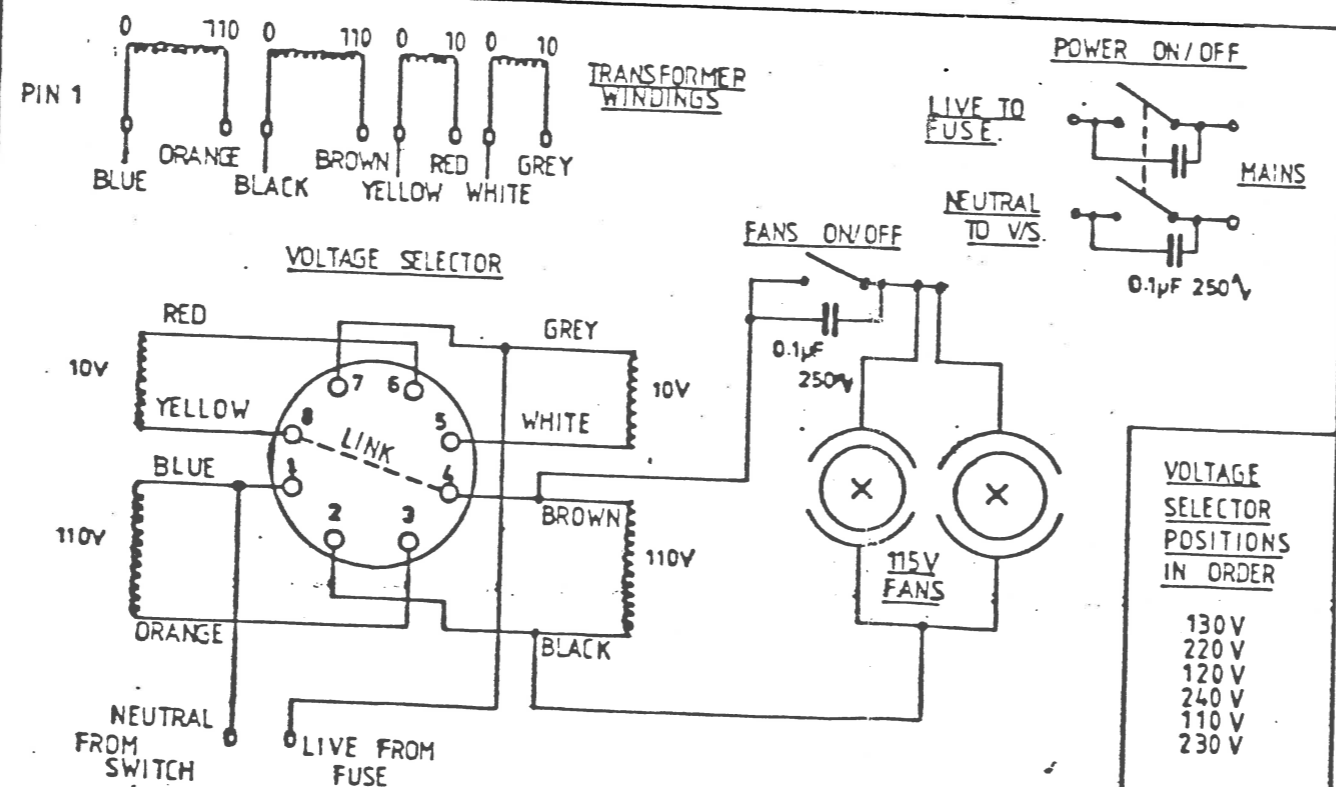
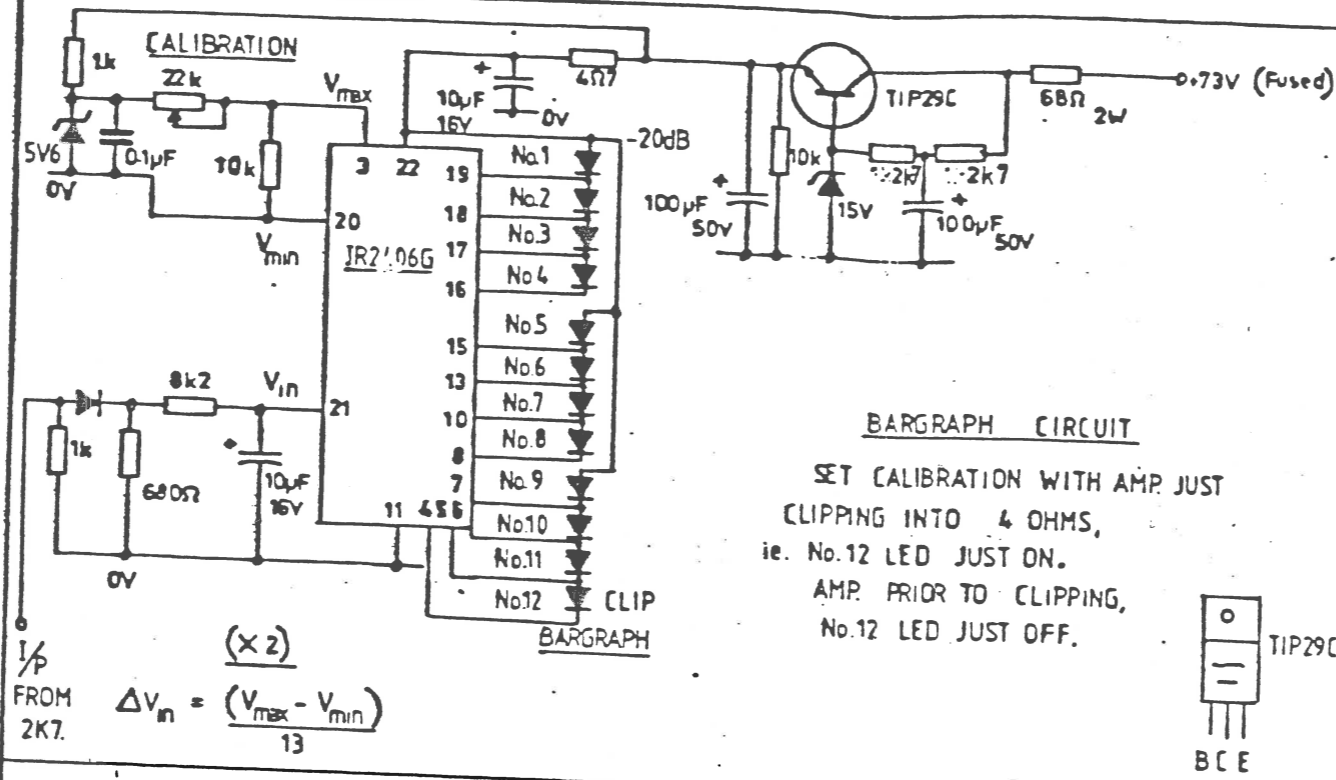

- VOLTAGE SELECTOR POSITIONS IN ORDER**
- 130V
 - 220V
 - 120V
 - 240V
 - 110V
 - 230V

BACK PANEL INPUT / OUTPUT DETAILS

| | | | |
|-----------------|----------------------|-----------|---------------|
| INPUT:- | 1x MALE | 1x FEMALE | XLR |
| | PIN 1 - EARTH | | |
| | PIN 2 - BALANCED 2 | | |
| | PIN 3 - " 1 | | |
| | and UNBALANCED INPUT | | |
| OUTPUT:- | 2x MALE XLR | | PIN 1 - EARTH |
| | 2x TERMINAL POST | | PIN 2 - LIVE |

INPUT ARRANGEMENTS:

- a) Balanced Connected Earth } 600 Ohm Transformer
- b) " Isolated " } OPTIONAL
- c) Unbalanced Connected Earth
- d) " Isolated " (10K Ohm Transformer) OPTIONAL

CONDITIONS:-

- b) & d) Cut wire between XLR Pin 1 and SOCKET Pin 3-8
- d) Connect Pins 1 & 2 on XLR.

INPUT ISOLATION TRANSFORMER SOCKET. TOP VIEW
STANDARD UNBALANCED PLUG CONNECTS 4-5 ON SOCKET.
OPTIONAL ISOLATION TRANSFORMER PIN CONFIGURATION
 3 SCREEN 10K:10K SOWTER 5127

PROTECTION BOARD (2 OFF)

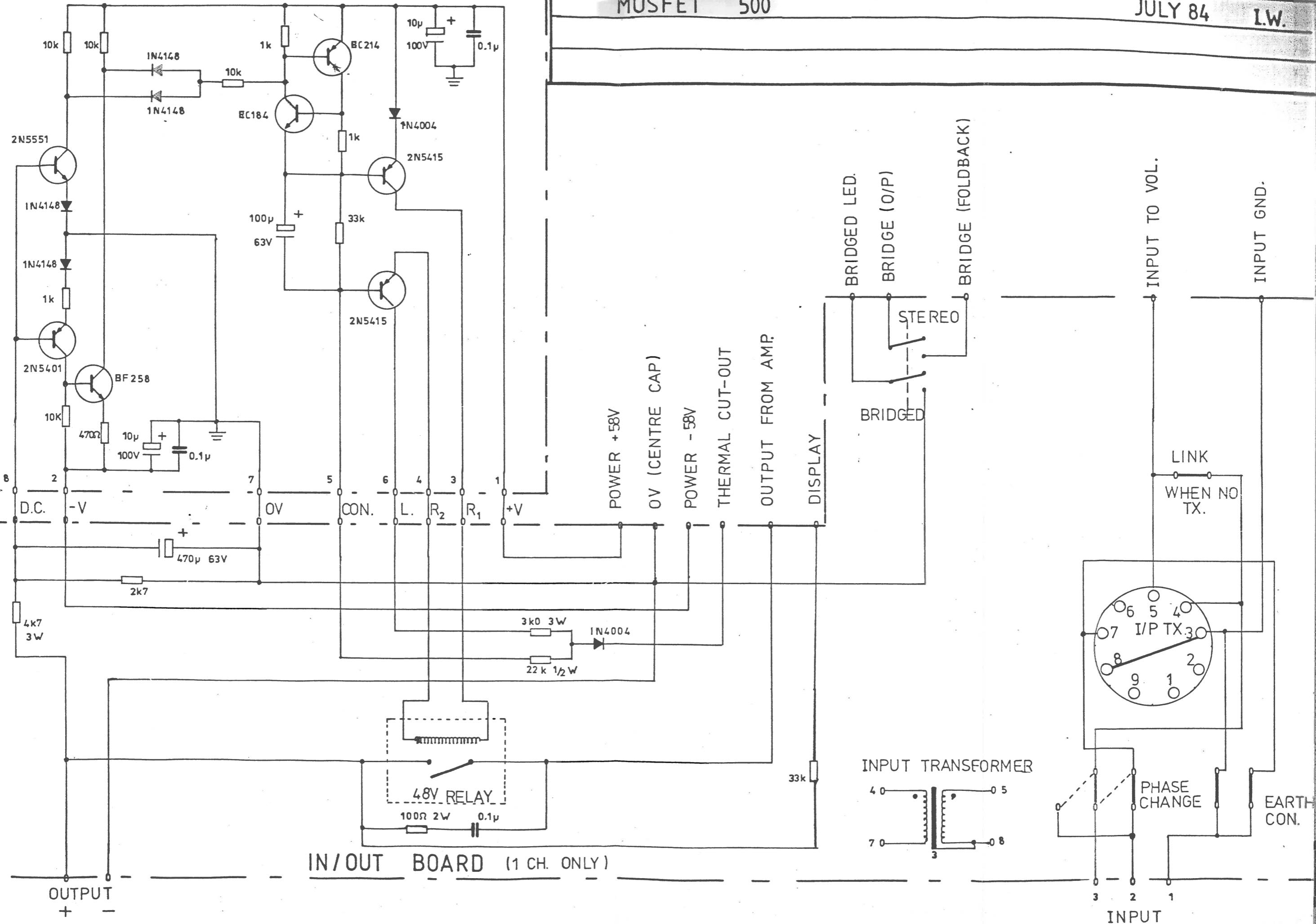

IN/OUT BOARD (1 CH. ONLY)

OUTPUT
+ -

INPUT

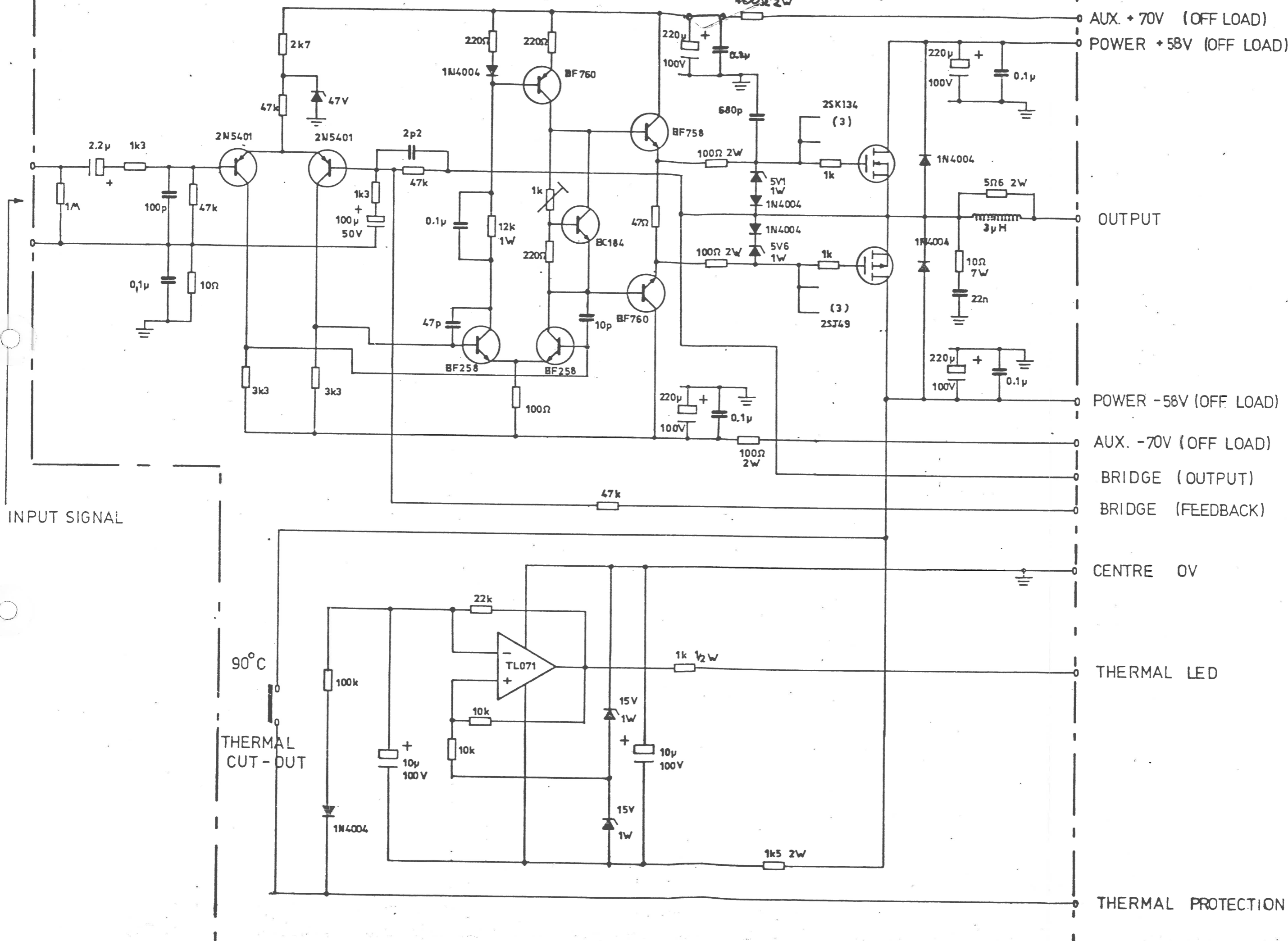

AUX. + 70V (OFF LOAD)
 POWER + 58V (OFF LOAD)
 OUTPUT
 POWER - 58V (OFF LOAD)
 AUX. - 70V (OFF LOAD)
 BRIDGE (OUTPUT)
 BRIDGE (FEEDBACK)
 CENTRE 0V
 THERMAL LED
 THERMAL PROTECTION TRIP

AMPLIFIER BOARD SM5/10-1-1
 C.C.T. SM5/10-CCT1-1 (500)
 JULY 84
 I.W.

STUDIO MASTER MOSFET 500

FUSE BOARD

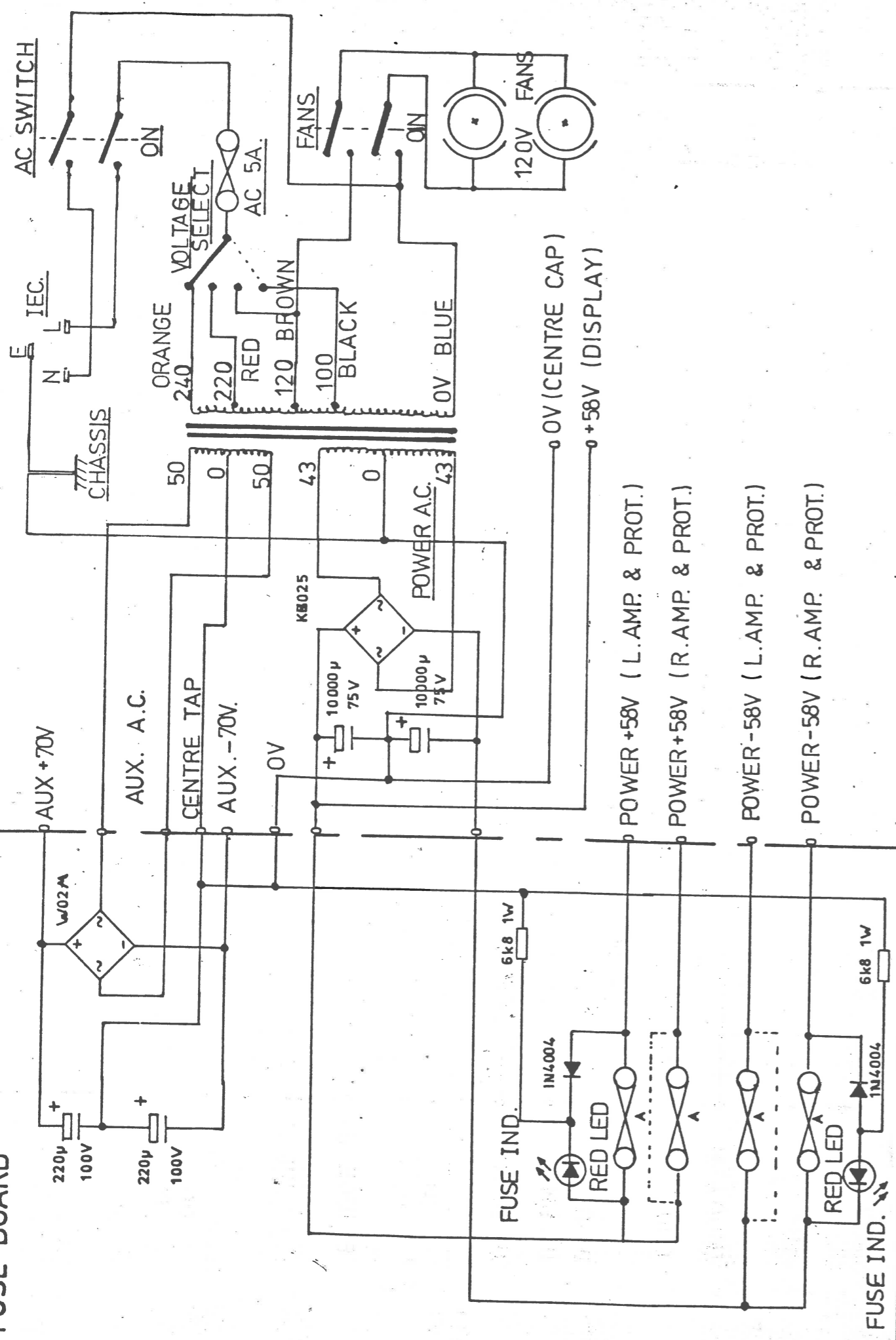

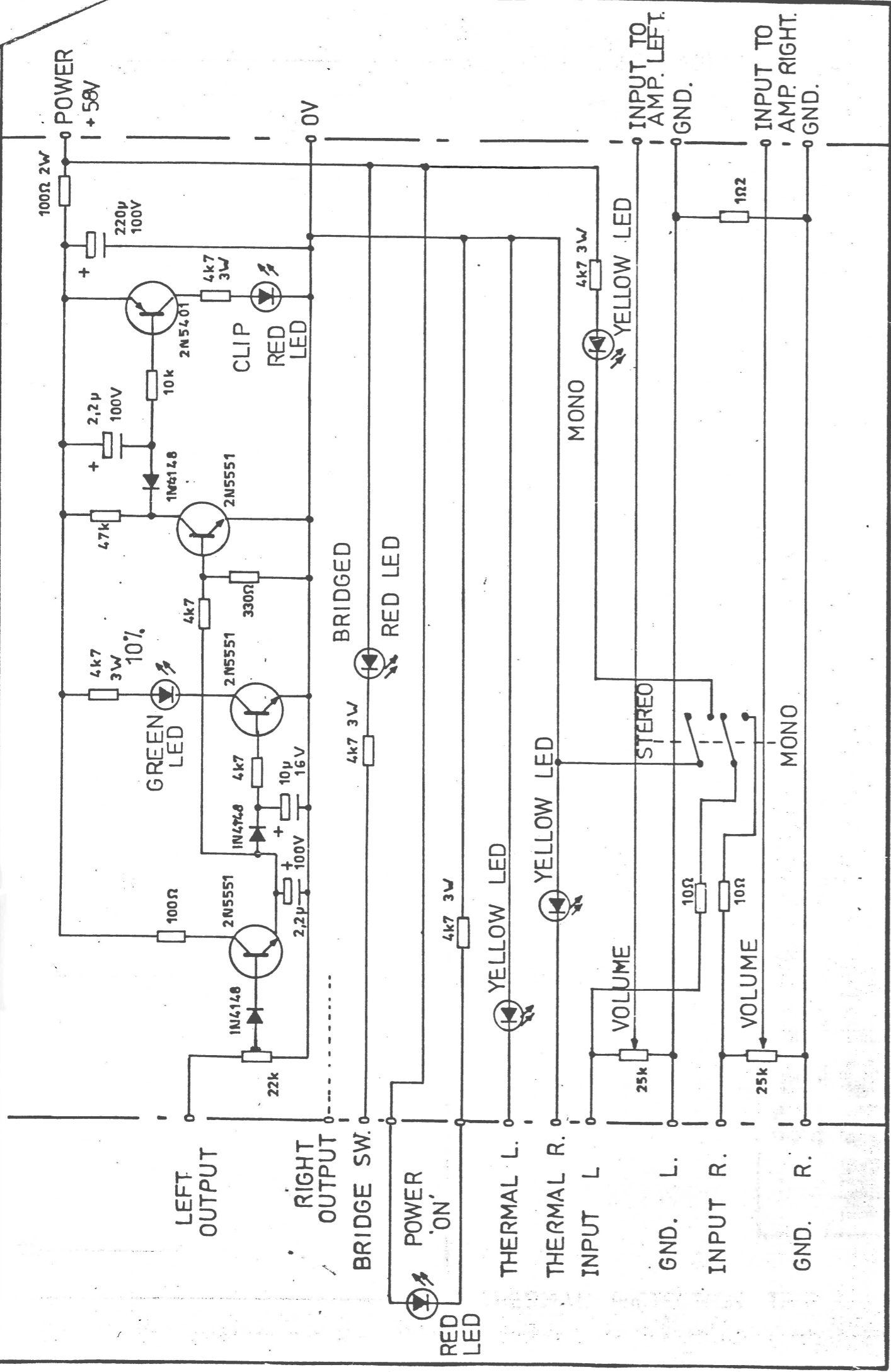

M O S F E T 1 0 0 0

Amp Board - Description

The Mosfet 1000 amplifier boards are of a standard configuration commonly found in IC designs.

The circuit consists of a differential input stage followed by a further differential stage which has a current minor load. This stage then feeds a standard common emitter, class A push pull, buffer. This configuration gives very low distortion and very high gain.

The distortion at full power 8 ohm loads should be below 0.008% T.H.D. If this is too high it is most likely due to incorrect I.D.C. wiring causing loss of one or more fets.

Distortion at full power 4 ohms should be below 0.025% T.H.D. At low frequency, eg., 1kHz, distortion should be below 0.002%. Distortion readings must be taken after the amplifier has warmed up. The amplifier is very fast, the slew rate being in excess of 100V/usec. A 20kHz square wave should be quite rectangular with no overshoot or ringing at all into resistive loads.

The 680pf capacitor at the gate drive to the V Fets must not be a ceramic type as these are non linear and therefore cause distortion.

The earth link on the back of the board must be connected as shown otherwise there will be an increase in distortion at high frequencies.

The distortion measurements are specified with reference to the Radford equipment used and are limited as such. Actual distortion at 4ohms/1Khz is approximately 0.005%.

M O S F E T 1 0 0 0

Amp Board

Once the amplifier board has been assembled and checked for the right components, polarity of capacitors, etc., the board must have the correct bias voltage set by use of the 1K variable resistor on the board. This bias voltage is used to set the quiescent bias current through the output VMOS devices at 100mA per device.

Procedure:

- 1) Have both boards, (driver and auxiliary) connected up correctly.
- 2) Set the 1K resistor to mid position.
- 3) Apply power and check that the boards are functioning correctly by feeding in sine and square waves and monitoring the output. (1KHz frequency).
- 4) Allow the board to reach its normal running temperature, i.e., BF761/BF762 at about 70°C. (The full heatsink must be fitted for this procedure).
- 5) Switch off power and insert an ammeter in one of the power leads and switch on with the signal generator off.
- 6) Turn the variable resistor until a reading of 500mA is obtained (+ 20mA).
- 7) Switch off and disconnect the meter.
- 8) Switch on again and short circuit the output for 15 seconds. Remove short and make sure amplifier is still functioning correctly.
- 9) Recheck the bias current as per 5 and 6 and reset if necessary to 500mA.
- 10) The heatsink will be quite warm even with no load as it will be dissipating about 70 watts.
- 11) The transistors on the board will also be quite warm. BF761 - BF758 on the heatsinks will be about 70°C. BF258 metal can devices will be about 90°C.

These devices are well within the operating limits despite the high temperature.
- 12) The bias must be set at the normal running temperature of the amplifier otherwise the drive and output transistor could overheat if the bias is set cold.

These temperatures are reference to 25°C AMBIANT.

Protection Circuits

The protection circuits operate whenever a D.C. potential exists at the amplifier output, or whenever overheating of the amplifier occurs. In both instances the load loudspeaker is disconnected by a relay which protects the loudspeaker or allows the amplifier to cool down, depending on the fault mode.

With reference to the protection board circuit diagram:-

The relay is held on during normal operation by T5. It is disconnected either by a signal at the base of T5, or by the thermal switch operating.

D.C. Detector

The amplifier output is fed to a low pass filter, which gives an output for D.C. or excessive low frequency energy. This signal turns on T1 or T2, depending on its polarity. These transistors then activate a latch consisting of T3 and T4. This latch puts a low impedance across the base of T5 thereby turning T5 off which disengages the relay. Once fired the latch will stay on until power is removed. The circuit will detect about +3.5 volts or full output swings below about 5Hz. There is a capacitor across the relay coil to give a delayed switch on to the load in order to eliminate start up pulses. This capacitor also causes a slight delay in fault detection but is of no concern.

Set-up Notes

- 1) The input capacitor must be in circuit when testing otherwise false triggering of the latch may occur. (The low pass filter cap).
- 2) The latch transistors (BC214, BC184) must not be replaced by the 2N5551, 2N5401, input transistors otherwise false triggering may occur.
- 3) Earthing must be correct, also to avoid false triggering.

Thermal Detection

A bimetal cutout is attached to the amplifier heatsink. This opens at the required protection temperature, 90 degrees, and disconnects the relay. When the thermal circuit operates power is supplied to I.C.1., which is configured as a simple astable multivibrator, thereby giving a visual indication of thermal shutdown by means of a pulsating light emitting diode mounted on the front panel. When the amplifier resumes normal temperature the relay will reconnect the load automatically.

Set-up Notes

- 4) The D.C. protection circuit will override the thermal control, i.e., if the thermal circuit comes into operation and then a D.C. fault occurs later the relay will stay disconnected and not reconnect the load at all, even when the amplifier resumes normal temperature.
- 5) If there is no D.C. fault but the relay does not reconnect the load when the thermal LED is extinguished (after a thermal overload) there is a protection board fault.
- 6) The latch circuit is very sensitive, touching the base of the BC214 or BC184 or nearby components can trigger the latch. The circuit however, is very stable in normal operation and will not trigger except when a valid D.C. fault is present at the output of the amplifier. (The load is disconnected after about 3 seconds).