

TANBERGS RADIOFABRIKK A/S
N - 1301 Sandvika - Norway

1450 - 11 - 76 Part No. 714023
Printed in Norway by Sem & Stenersen A/S

TANDBERG

10 X Service Manual



Tandberg
RADIO

CONTENTS

	page
Introduction	2
Maintenance	3
Changing the power supply transformer tapings	3
Changing from NAB correction to IEC correction	4
Electrical adjustments	5
Circuit diagrams and printed boards	6

INTRODUCTION

All paragraphs in this manual are valid for model 10X. For mechanical servicing, use the Service Manual for model 10XD.

GENERAL

Only HL (High output/Low noise) tape should be used for recording. Make sure that the heads and tape path are clean.

To check the heads, simply remove the two head covers. They should be pulled straight off.

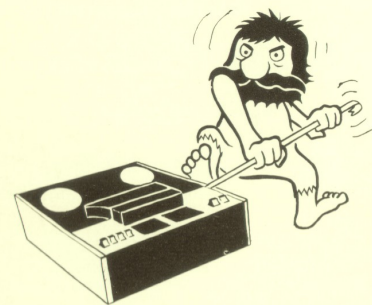

When electrical adjustment are to be made the wooden cabinet must be removed. Lay the 10X carefully down on the front. Remove the four mounting screws as shown in Figure 1.1. The cabinet should be pulled straight off.

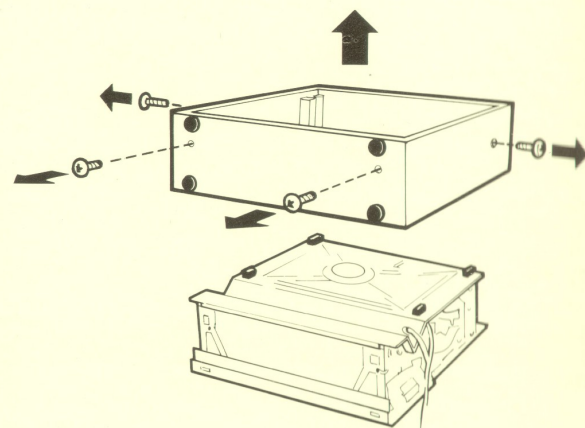

MAINTENANCE

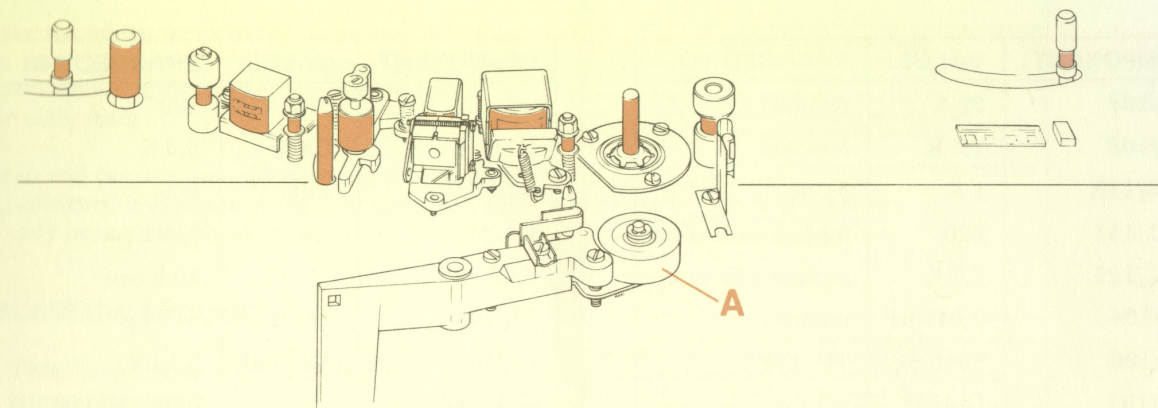

Fig. 2.1 Cleaning the tape path

CLEANING THE TAPE PATH

It is important that the tape path is clean before adjustments are made. The tape tension arms must also be cleaned. If the heads or guide posts have been adjusted, the tape path must be de-magnetized.

Cleaning should be carried out with cotton-bud sticks (Q tips) moistened with *pure alcohol or methylated spirits*. A special cleaning kit called "Tandberg Professional Tape Head Cleaner" is also available.

Aerosol sprays indented for video tape recorders may be used, but it is not sufficient just to spray the parts; cotton-bud sticks must also be used.

Obstinate deposits on guide posts should be first well softened and then removed with the aid of a toothpick.

CHANGING THE POWER SUPPLY TRANSFORMER TAPPINGS

Since the machine employs a photo-electric sensor for speed regulation, the speed is not dependent on the power frequency.

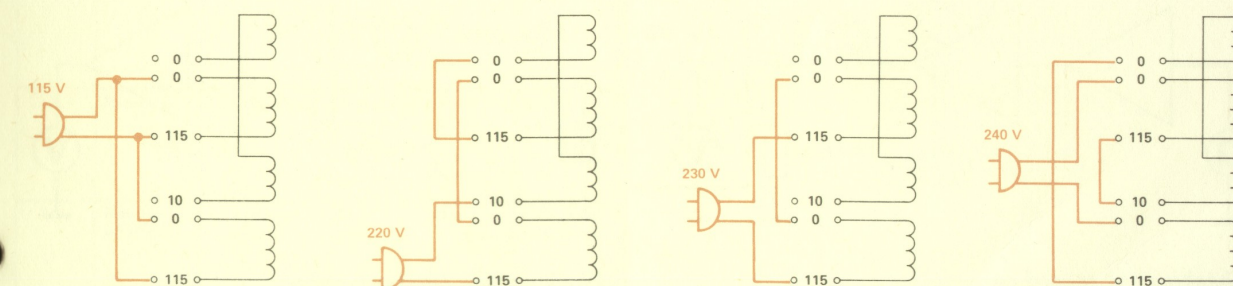

The pinch roller A should be cleaned if the tape runs unevenly or if there are visible deposits on the roller (4 to 6 times a year should be sufficient, even if the tape recorder is much used). Make sure that the pinch roller is dry after cleaning.

LUBRICATION

The pinch roller and the flywheel have self-lubricating bearings and must not be lubricated. The reel motors and the capstan motor needs no lubrication.

To change the wiring of the power supply transformer to suit another power supply voltage, see Figures. The power lead must be connected to the primary of the transformer as shown in the relevant Figure.

CHANGING FROM NAB CORRECTION TO IEC CORRECTION

COMPONENT:	VALUE:	CHANGED TO:
R7/107	22 K	removes
R8/108	1,5 K	removes
R10/110	1 K	3,3 K
R11/111	220	replace with strap
R21/121	2,7 K	replace with strap
C4/104	0,047 uF	removes
C6/106	3300 pF	4700 pF
D1/101	IN4148	removes
D2	IN4198	removes

Record amplifier A7

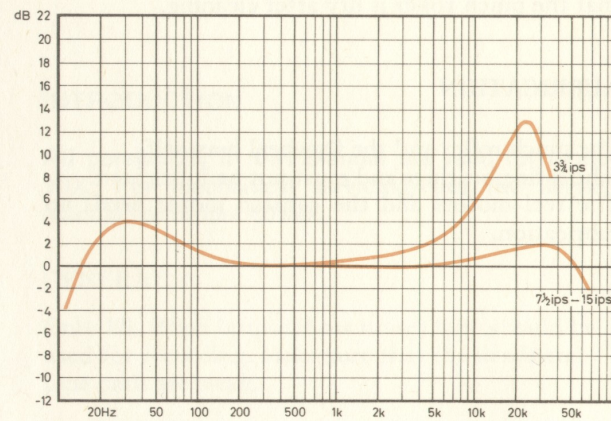

IEC record curve

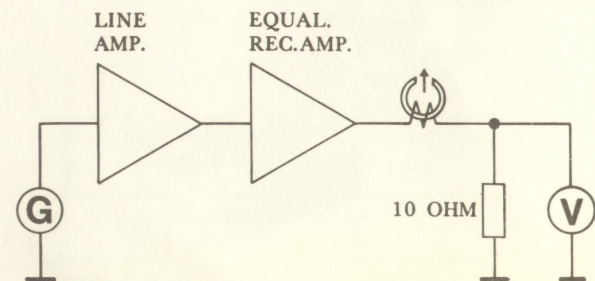

Checking the record curve

COMPONENT:	VALUE:	CHANGED TO:
R9/109	220	180
R11/111	1,5 K	3,3 K
R12/112	150	100
R21/121		330 new
R22/122		10 k new
C6/106	0,022 uF	4700 pF
C7/107	0,068 uF	0,1 uF
C12/112		0,047 uF new
D5/105		IN4148 new
D6/106		IN4148 new

Playback amplifier A11

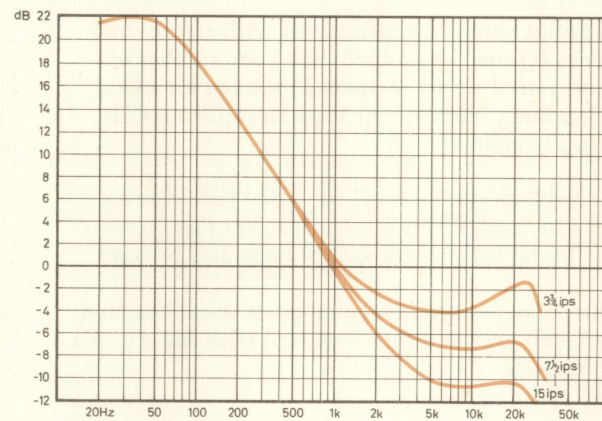

IEC playback curve

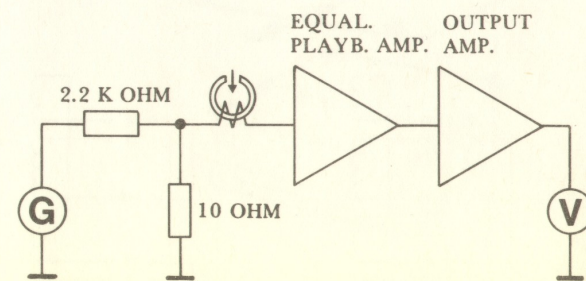

Checking the playback curve

ELECTRICAL ADJUSTMENTS

Make the adjustments in the order in which they are listed here. Many of the adjustments require that previous adjustments have already been correctly made.

Clean and degauss the tape path before and after adjustments. It is assumed that the tape path has already been correctly adjusted.

NECESSARY EQUIPMENT

- 2 high impedance voltmeters (do NOT use universal meters).
- Frequency counter.
- Audio generator.
- Distortion meter.
- Wow meter (required for wow test only).
- Test Tapes:
 - No. 1 - Height adjustment, 4 track playb. head.
 - No. 2 - Azimuth adj. playb. head 15,000 Hz, 7 1/2 ips.
 - No. 3 - Playb. curve, DIN 19H, 7 1/2 ips.
 - No. 4 - Playb. level adj., 400 Hz, 7 1/2 ips.
 - No. 9 - Full track, 1000 Hz. Erase head adj.
 - No. 11 - Speed check, 1000 Hz, 7 1/2 ips.

Only HL (High Output/Low Noise) tape should be used for recording. Make sure that the heads and tape guides are clean. To check the heads, simply remove the two head covers. They should be pulled straight off.

PULL-IN TIME FOR ARMATURES AND STARTING VOLTAGE FOR THE REEL MOTORS

When the machine is in the STOP mode and the PLAY button is pressed the reel motors receive extra voltage at the moment of starting to prevent tape loops forming. (Remember to depress the 10 1/2" REEL button when 10 1/2" reels are in use). The duration of this extra voltage can be adjusted by means of pot. R36 on the logic board. R36 should be adjusted so that the pull-in time is about 250 ms. This delay can be checked on U26-9 with the aid of an oscilloscope.

Test No.	Adjustment or check	Test tape No.	Set the deck to	Measuring instrument	Measure at:	Adjust	Correct reading	Speed	Comments
1.1	Playback head, azimuth	2	Playback	a.c. voltmeters	LINE OUT	Azimuth screw	Maximum output	7 1/2"	Maximum output or best compromise.
1.2	Playback curve, DIN 19H	3	Playback	a.c. voltmeters	LINE OUT	Playback EQ. adj. R46-R146	+ 3 dB. at 18 KHz	7 1/2"	Playback curve, Din 19H. The tape contains the following frequencies: 1000 Hz (reference) 18 kHz, 15 kHz, 10 kHz, 4 kHz 125 Hz, 40 Hz, 1000 Hz (ref.) Adjust R46 - R146 to + 3 dB at 18 KHz.
1.3	Playback level	4	Playback	a.c. voltmeters	LINE OUT	PLAYBACK LEVEL R31-R131	1,0 V	7 1/2"	
1.4	Playback meter adjustments	-	See comments	a.c. voltmeters	LINE OUT	PLAYBACK METER R30-R130	1,5V	7 1/2"	To be performed without tape. Put a piece of paper between the light source and the phototransistor. Set the deck in SOURCE. Depress the PLAY button. Connect an audio-generator, 1000 Hz to LINE IN. Adjust with the LINE INPUT LEVEL to 1.5V on the voltmeters. Adjust R30 (L) and R130 (R) to 0 dB indication on the meters.
1.5	Speed	11	Playback	Frequency counter	LINE OUT	R40-15" R41-7 1/2" R42-3 3/4"	± 0.3% 997-1003 Hz in 7 1/2"	All	Test-tape No. 11 are recorded at 1000 Hz in 7 1/2". Start in 15". Adjust R40 to correct speed. Then adjust R41 in 7 1/2" and R42 in 3 3/4". R40/R41/R42 are on the motor control board.
1.6	Bias pre-adjustment	-	Record	a.c. voltmeter	See comments	Bias adj. R44-R144	Approx. 22V	7 1/2"	To be performed without tape. Measure across the bias head or on pin 2 (L) and pin 3 (R) on contact P11 on the main board.

ELECTRICAL ADJUSTMENTS

Make the adjustments in the order in which they are listed here. Many of the adjustments require that previous adjustments have already been correctly made.

Clean and degauss the tape path before and after adjustments. It is assumed that the tape path has already been correctly adjusted.

NECESSARY EQUIPMENT

- 2 high impedance voltmeters (do NOT use universal meters).
- Frequency counter.
- Audio generator.
- Distortion meter.
- Wow meter (required for wow test only).
- Test Tapes:
 - No. 1 - Height adjustment, 4 track playb. head.
 - No. 2 - Azimuth adj. playb. head 15,000 Hz, 7 1/2 ips.
 - No. 3 - Playb. curve, DIN 19H, 7 1/2 ips.
 - No. 4 - Playb. level adj., 400 Hz, 7 1/2 ips.
 - No. 9 - Full track, 1000 Hz. Erase head adj.
 - No. 11 - Speed check, 1000 Hz, 7 1/2 ips.

Only HL (High Output/Low Noise) tape should be used for recording. Make sure that the heads and tape guides are clean. To check the heads, simply remove the two head covers. They should be pulled straight off.

PULL-IN TIME FOR ARMATURES AND STARTING VOLTAGE FOR THE REEL MOTORS

When the machine is in the STOP mode and the PLAY button is pressed the reel motors receive extra voltage at the moment of starting to prevent tape loops forming. (Remember to depress the 10 1/2" REEL button when 10 1/2" reels are in use). The duration of this extra voltage can be adjusted by means of pot. R36 on the logic board. R36 should be adjusted so that the pull-in time is about 250 ms. This delay can be checked on U26-9 with the aid of an oscilloscope.

Test No.	Adjustment or check	Test tape No.	Set the deck to	Measuring instrument	Measure at:	Adjust	Correct reading	Speed	Comments
1.1	Playback head, azimuth	2	Playback	a.c. voltmeters	LINE OUT	Azimuth screw	Maximum output	7 1/2"	Maximum output or best compromise.
1.2	Playback curve, DIN 19H	3	Playback	a.c. voltmeters	LINE OUT	Playback EQ. adj. R46-R146	+ 3 dB. at 18 KHz	7 1/2"	Playback curve, Din 19H. The tape contains the following frequencies: 1000 Hz (reference) 18 kHz, 15 kHz, 10 kHz, 4 kHz 125 Hz, 40 Hz, 1000 Hz (ref.) Adjust R46 - R146 to + 3 dB at 18 KHz.
1.3	Playback level	4	Playback	a.c. voltmeters	LINE OUT	PLAYBACK LEVEL R31-R131	1,0 V	7 1/2"	
1.4	Playback meter adjustments	-	See comments	a.c. voltmeters	LINE OUT	PLAYBACK METER R30-R130	1,5V	7 1/2"	To be performed without tape. Put a piece of paper between the light source and the phototransistor. Set the deck in SOURCE. Depress the PLAY button. Connect an audio-generator, 1000 Hz to LINE IN. Adjust with the LINE INPUT LEVEL to 1.5V on the voltmeters. Adjust R30 (L) and R130 (R) to 0 dB indication on the meters.
1.5	Speed	11	Playback	Frequency counter	LINE OUT	R40-15" R41-7 1/2" R42-3 3/4"	± 0.3% 997. 1003 Hz in 7 1/2"	All	Test-tape No. 11 are recorded at 1000 Hz in 7 1/2". Start in 15". Adjust R40 to correct speed. Then adjust R41 in 7 1/2" and R42 in 3 3/4". R40/R41/R42 are on the motor control board.
1.6	Bias pre-adjustment	-	Record	a.c. voltmeter	See comments	Bias adj. R44-R144	Approx. 22V	7 1/2"	To be performed without tape. Measure across the bias head or on pin 2 (L) and pin 3 (R) on contact P11 on the main board.

Test No.	Adjustment or check	Measuring instrument	Measure at:	SOURCE/ TAPE buttons	Set the deck to	Procedure
2.1	Bias head horizontal adjustment	a.c. voltmeters	LINE OUT	TAPE	RECORD 7 1/2"	Connect an audio-generator to LINE IN. Set the generator to 1000 Hz and adjust with the LINE INPUT LEVEL to approx. 2V on the voltmeters. Turn the 2 mm Allen screw clockwise and the head moves to the left. Then turn the screw counter clockwise to maximum reading on the voltmeters. Use the first maximum when the head moves from the left to the right side.
2.2	Azimuth, record head	a.c. voltmeters	LINE OUT	TAPE	RECORD 3 3/4"	Connect an audio-generator to LINE IN. Start stereo recording in 3 3/4 IPS of a 1000 Hz signal 30 dB below normal recording level (0 dB). Use the voltmeter readings as reference level. Then record a 16000 Hz signal and turn the azimuth screw on the record head to maximum reading on the voltmeters.
2.3	Record/playback curves	a.c. voltmeters	LINE OUT	TAPE	RECORD all speeds	Connect an audio-generator to LINE IN. Start recording in 3 3/4" of a 1000 Hz signal 30 dB below normal recording level (0 dB). Use the voltmeter readings as reference level. Then record a 18,000 Hz signal at the same level and check that the output is within ±2 dB. If the output is too high, increase bias current with R44 (L) and R144 (R). If the output is too low, alter the signal frequency to 1000 Hz and adjust for maximum output with R44 (L) and R144 (R). Then establish a reference level, and re-check the output at 18,000 Hz. When the tolerance at 18,000 Hz has been met, check that the output level not deviate more than ± 2 dB from the following frequencies: 15" ± 2 dB 30-25,000 Hz 7 1/2" ± 2 dB 30-22,000 Hz 3 3/4" ± 2 dB 40-18,000 Hz When adjusting the record-playback curve in 15 ips. use tape with 15u magnetic coating. If tape with 10u magnetic coating are used, the higher frequencies will raise approx. 2 dB.
2.4	SOURCE/ TAPE	a.c. voltmeters	LINE OUT	SOURCE/ TAPE	RECORD 7 1/2"	Connect an audio-generator, 1000 Hz, to LINE IN. Adjust in SOURCE with the LINE INPUT LEVER to 0,5V on the voltmeters on the LINE OUT, (OUTPUT LEVEL controls to maximum). Set the deck to stereo recording and push the TAPE/SOURCE buttons down to TAPE. Then adjust RECORD LEVEL R19 - R119 so that the level reading is 1 dB higher on the voltmeters.
2.5	Record METER adjustment	a.c. voltmeter	-	SOURCE	RECORD 7 1/2"	Audio-generator 1000 Hz to LINE IN. Set the deck to SOURCE and in stereo recording. Adjust with the LINE INPUTS LEVEL to 1,5V on the voltmeters. Then adjust the record meters to 0 dB with R25 - R125.
2.6	Distortion	Distortion meter	LINE OUT	TAPE	RECORD 7 1/2"	Connect an audio-generator (or distortion meter generator) 1000 Hz to LINE IN. Record to 0 dB indication on the meters and read the distortion on the LINE OUT. Distortion, max. 3%.
2.7	Wow and flutter	Wow and flutter meter	LINE OUT	TAPE	RECORD All speeds	Connect the wow-and-flutter meter generator to the LINE IN. Read on the LINE OUT and in all speeds. If necessary, adjust R43 (on the motor control board) to minimum wow and flutter i 3 3/4". Wow and flutter max: 15" 7 1/2" 3 3/4" Peak, DIN 455" 0,07% 0,09% 0,15% Weighted R.M.S. 0,04% 0,06% 0,11%

Adjustment table 2

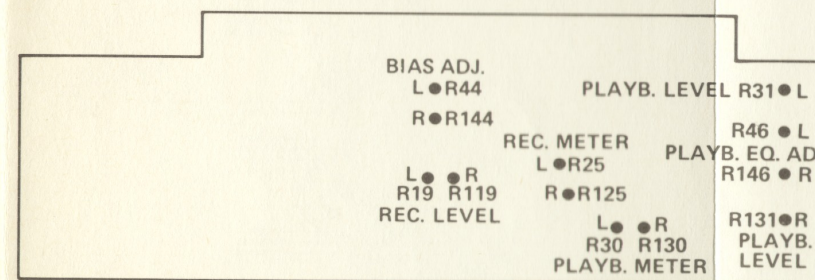

Location of adjustment points on the main board, solder side.



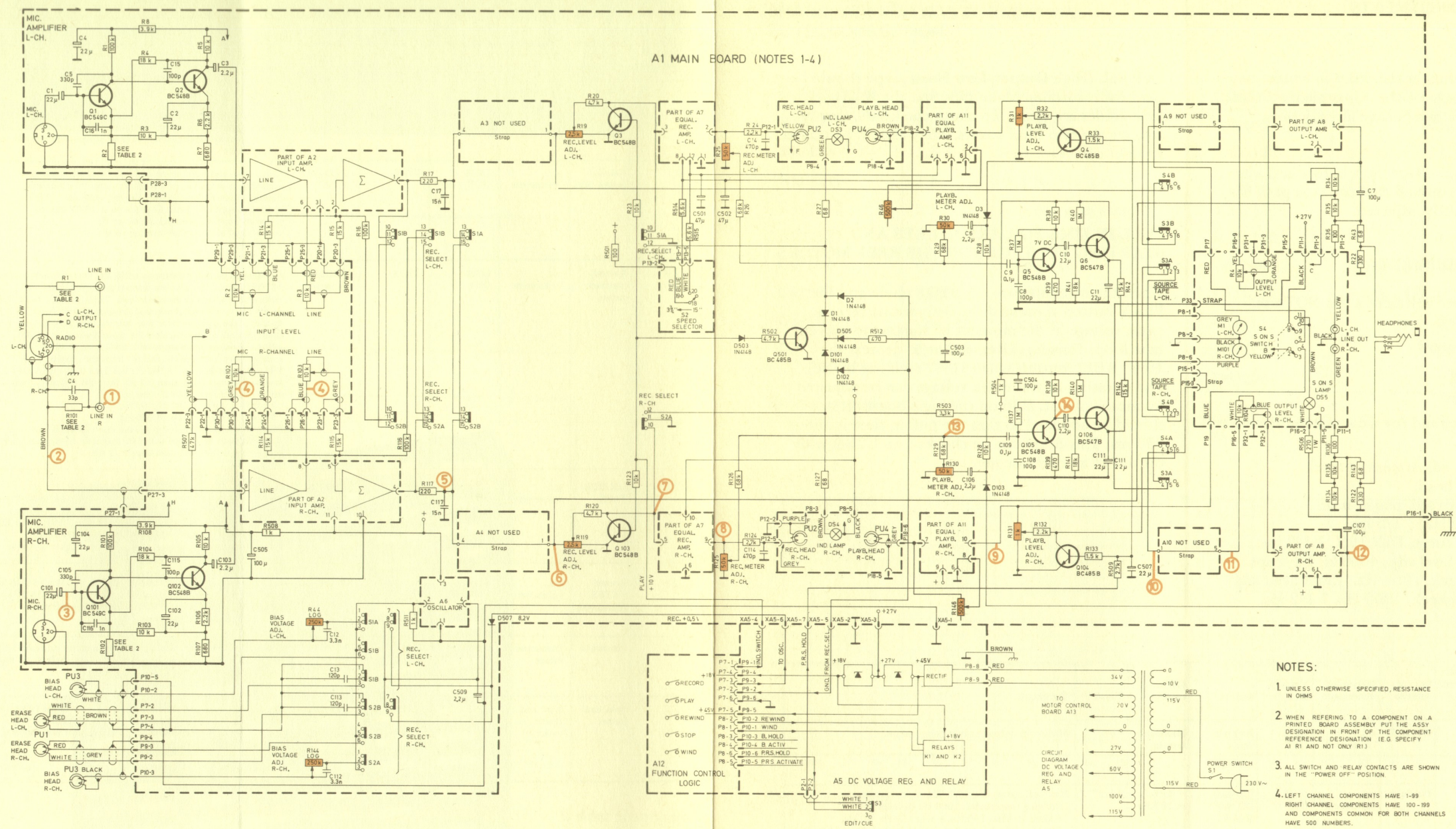

- NOTES:**
- UNLESS OTHERWISE SPECIFIED, RESISTANCE IN OHMS
 - WHEN REFERRING TO A COMPONENT ON A PRINTED BOARD ASSEMBLY PUT THE ASSY DESIGNATION IN FRONT OF THE COMPONENT REFERENCE DESIGNATION (E.G. SPECIFY A1 R1 AND NOT ONLY R1)
 - ALL SWITCH AND RELAY CONTACTS ARE SHOWN IN THE "POWER OFF" POSITION
 - LEFT CHANNEL COMPONENTS HAVE 1-99 RIGHT CHANNEL COMPONENTS HAVE 100-99 AND COMPONENTS COMMON FOR BOTH CHANNELS HAVE 500 NUMBERS.

ALL THE SWITCHES ARE SEEN FROM SOLDER SIDE (NOTE 2 AND 3)

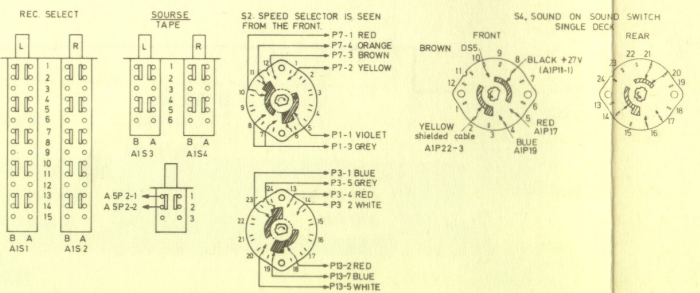

TABLE 1: SENSITIVITY OF AMPLIFIERS

L	R	SENSITIVITY AT 1000Hz AND 7.5 LIPS
1		30mV AT THE LINE IN SOCKET
2		8mV
3		230 μV (U.S. 0.5mV)
4		30 mV
5		80 mV
6		80 mV
7		4.5 mV
8		1.3 V
9		150 mV
10		100 mV
11		100 mV
12		1.5 V
13		150 mV
14		2 V

TABLE 2:

	230V/240V	115V
R1/R101	150k	88k
R2/R102 (A1)	56	220

A1 MAIN BOARD CIRCUITS DIAGRAM

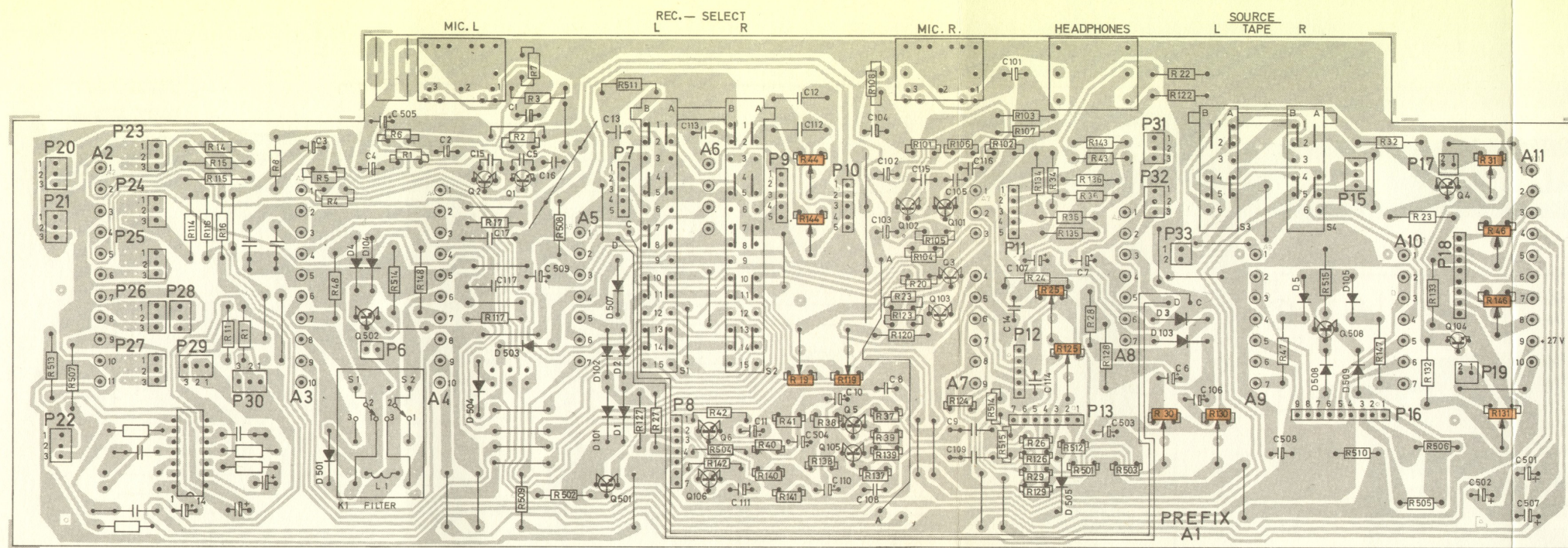

A1 MAIN BOARD

NOTES

1. UNLESS OTHERWISE SPECIFIED RESISTANCE IN OHMS.
2. WHEN REFERRING TO A COMPONENT ON A PRINTED BOARD ASSEMBLY PUT THE ASSY DESIGNATION IN FRONT OF THE COMPONENT REFERENCE DESIGNATION (E.G. SPECIFY A2R1 AND NOT ONLY R1).
3. ONLY THE L-CHANNEL OF THE ASSEMBLY DESIGNATED A2 IS SHOWN.
4. PLUG TERMINAL NO.'S FOR THE R-CHANNEL ARE GIVEN IN BRACKETS BESIDE THE L-CHANNEL PLUG TERMINAL NO.'S.
5. L-CHANNEL HAS 1-99 AND R-CHANNEL HAS 100-99 AS COMPONENT NO.'S. WHEN REFERRING TO R-CHANNEL COMPONENTS ADD 100 TO THE L-CHANNEL NO.'S (E.G. R10 OF THE L-CHANNEL HAS THE SAME VALUE AS R110 OF THE R-CHANNEL).
6. ALWAYS SPECIFY WHICH VERSION OF THE INPUT AMPLIFIER, THE US OR THE EU MODEL YOU ARE REFERRING TO, ESPECIALLY WHEN ORDERING COMPONENTS.

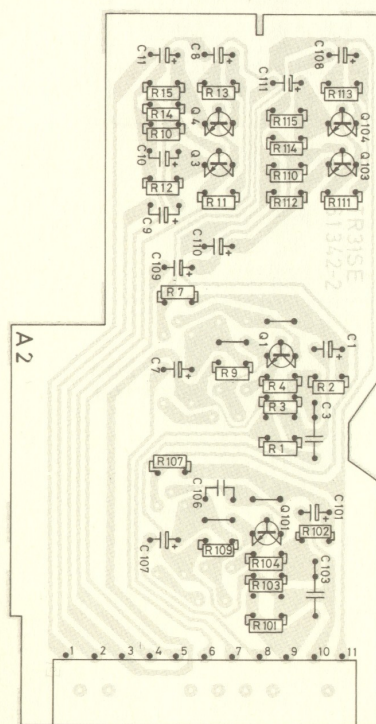

A2 INPUT AMP. BOARD, U.S. VERSION

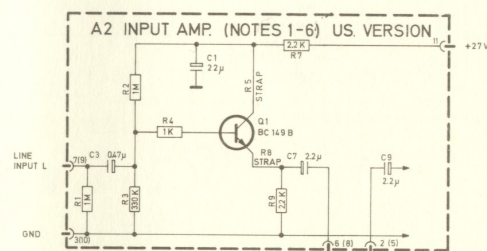

REFERENCE DESIGNATIONS (NOTE 6)	PREFIX WITH USA/2	NOT USED
C1, 3-11	C2, 4-8	
C10, 103, 107, 111	C102, 104, 105, 106	
Q1, 3, 8, 103, 104	Q2, 105	
R1-4, 7, 9-11	R5, 6, 8	
R101-104, 107, 109-111	R105, 106, 108	

COMPONENTS CHANGED ON USA/2	REF. DESIGN.	FROM	TO
	R2, 102	100 K	1M
	R3, 103	150 K	330 K
	R5, 105	27 K	0 (STRAP)
	R8, 108	3.5 K	0 (STRAP)

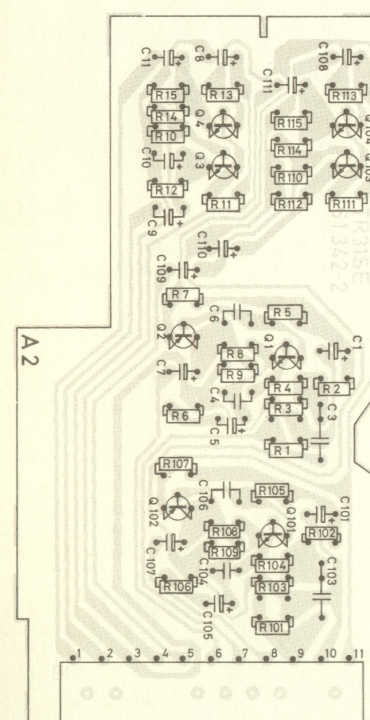

A2 INPUT AMP. BOARD, EUROPEAN VERSION

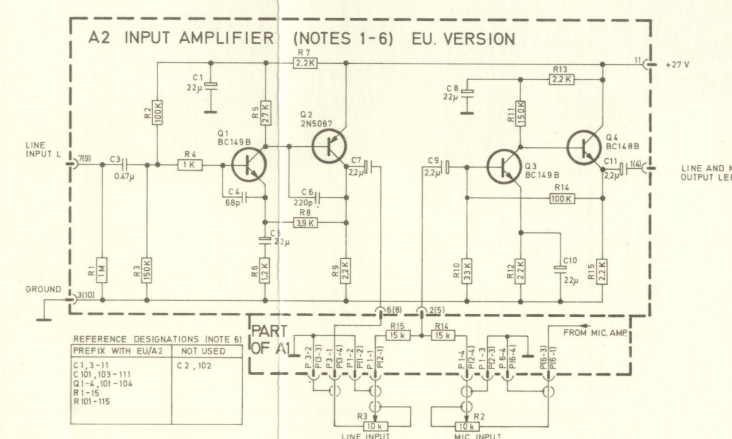

ALL THE BOARDS ARE SEEN FROM SOLDER SIDE

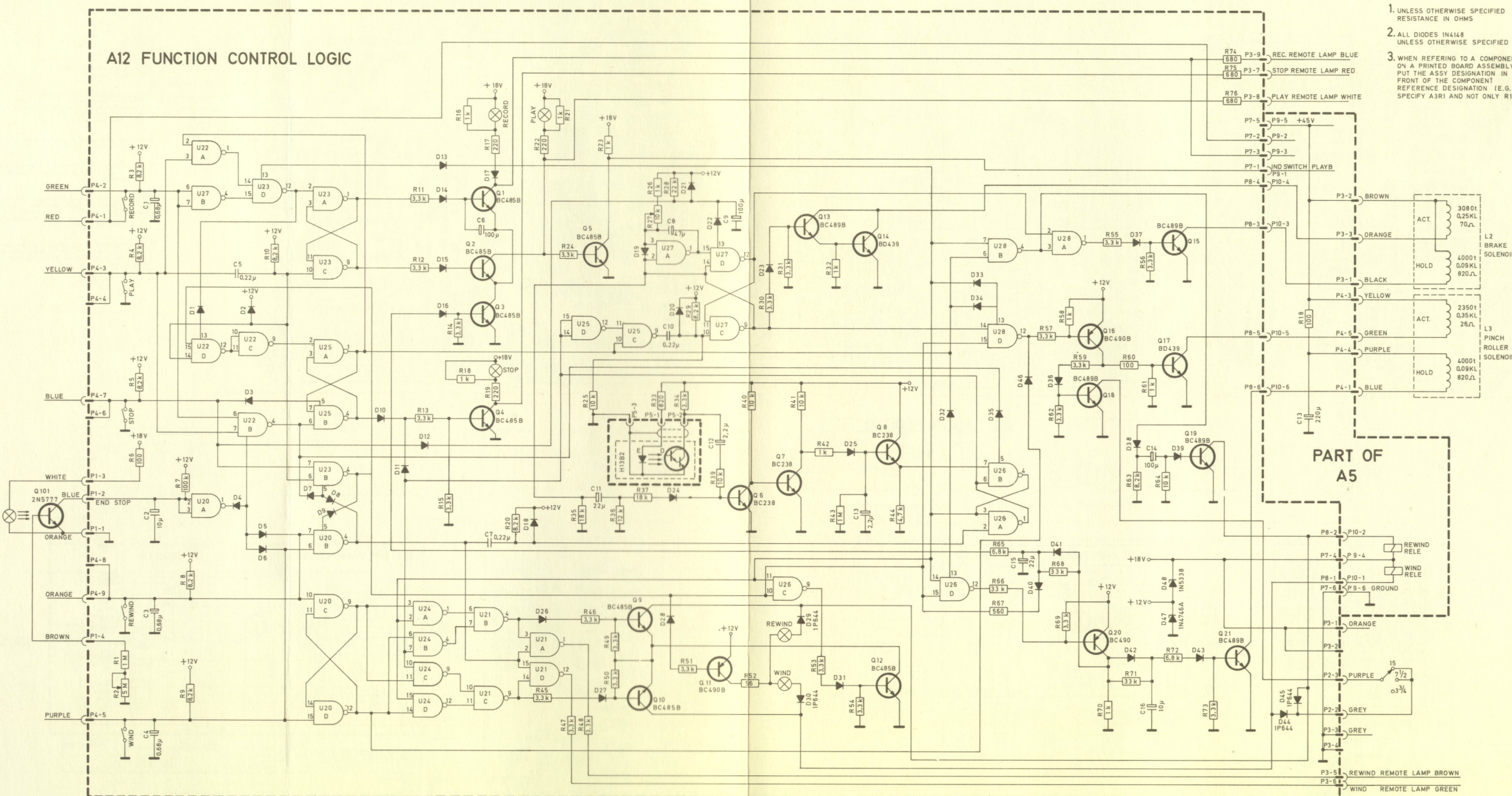

- NOTES**
1. UNLESS OTHERWISE SPECIFIED RESISTANCE IN OHMS
 2. ALL DIODES 1N4148 UNLESS OTHERWISE SPECIFIED
 3. WHEN REFERRING TO A COMPONENT ON A PRINTED BOARD ASSEMBLY PUT THE ASSY DESIGNATION IN FRONT OF THE COMPONENT REFERENCE DESIGNATION (E.G. SPECIFY A3R1 AND NOT ONLY R1)

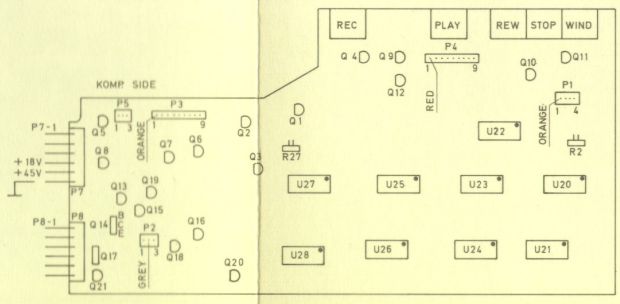
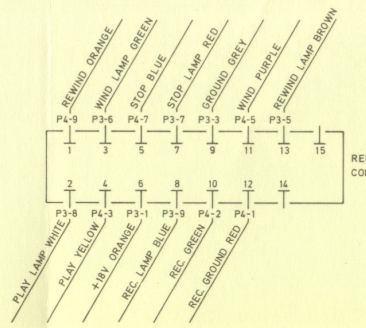
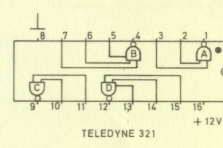

- NOTES**
1. UNLESS OTHERWISE SPECIFIED RESISTANCE IN OHMS
 2. ALL DIODES 1N4148 UNLESS OTHERWISE SPECIFIED
 3. WHEN REFERRING TO A COMPONENT ON A PRINTED BOARD ASSEMBLY PUT THE ASSY DESIGNATION IN FRONT OF THE COMPONENT REFERENCE DESIGNATION (E.G. SPECIFY A3R1 AND NOT ONLY R1)

A12 FUNCTION CONTROL LOGIC

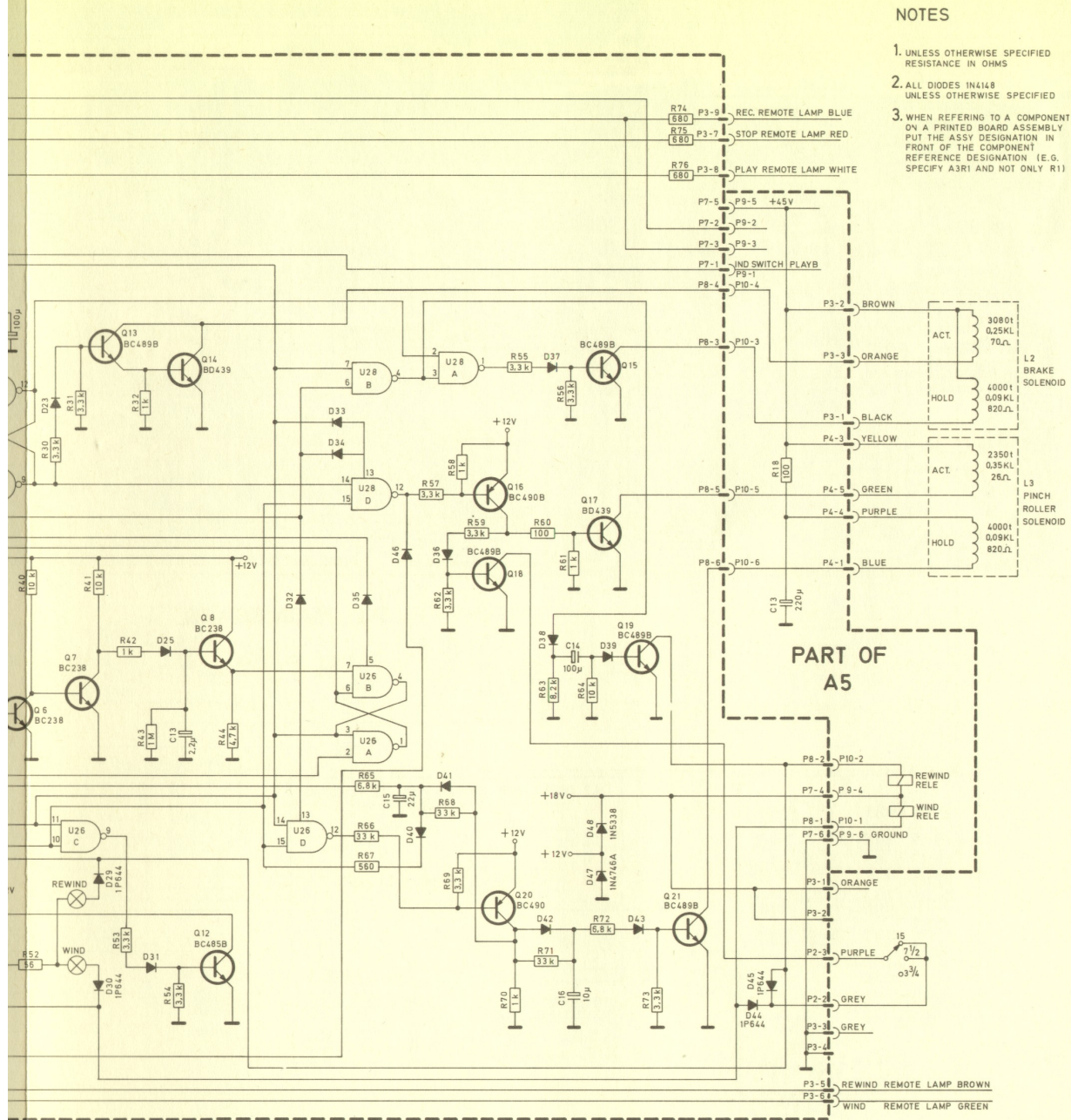

- NOTES
1. UNLESS OTHERWISE SPECIFIED RESISTANCE IN OHMS
 2. ALL DIODES IN4148 UNLESS OTHERWISE SPECIFIED
 3. WHEN REFERRING TO A COMPONENT ON A PRINTED BOARD ASSEMBLY PUT THE ASSY DESIGNATION IN FRONT OF THE COMPONENT REFERENCE DESIGNATION (E.G. SPECIFY A3R1 AND NOT ONLY R1)

PART OF A5

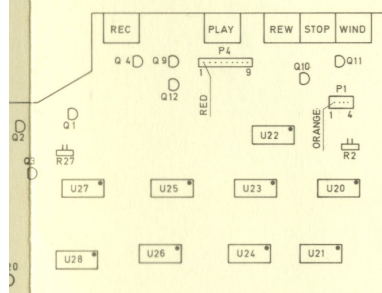

- NOTES
1. UNLESS OTHERWISE SPECIFIED RESISTANCE IN OHMS
 2. ALL DIODES IN4148 UNLESS OTHERWISE SPECIFIED
 3. WHEN REFERRING TO A COMPONENT ON A PRINTED BOARD ASSEMBLY PUT THE ASSY DESIGNATION IN FRONT OF THE COMPONENT REFERENCE DESIGNATION (E.G. SPECIFY A3R1 AND NOT ONLY R1)

CONTROL LOGIC

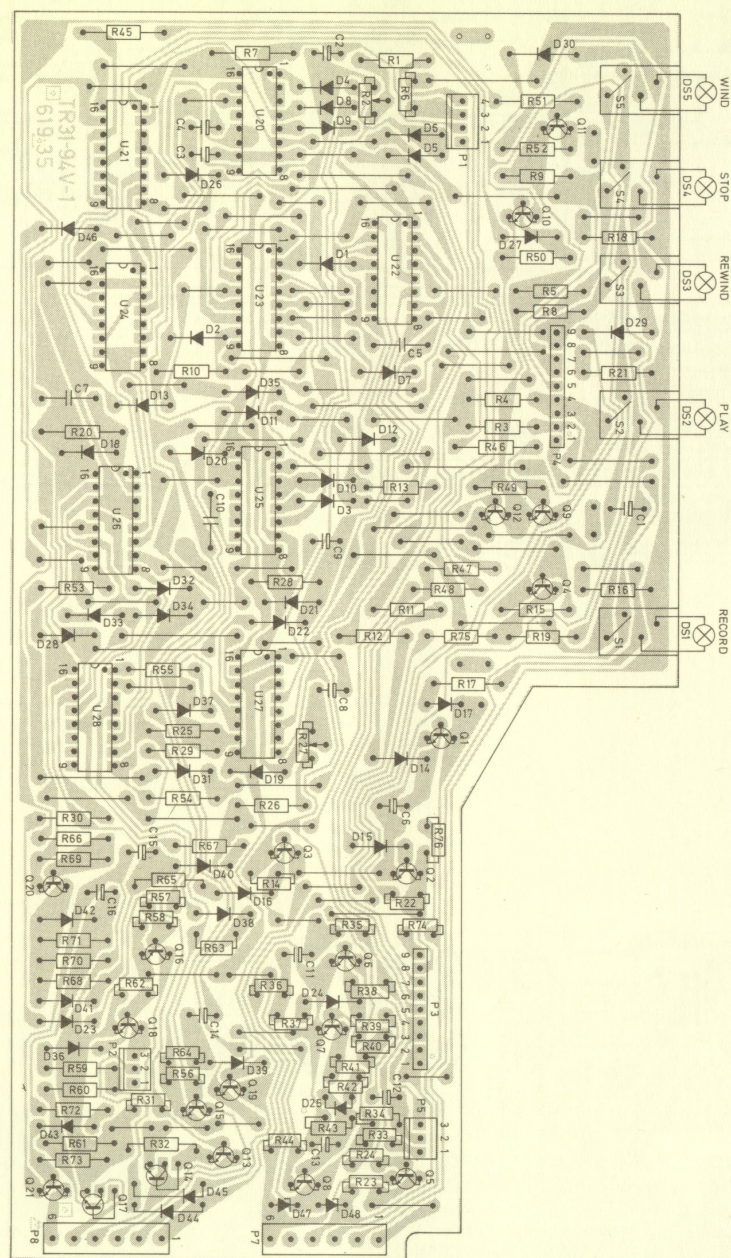

A12 LOGIC BOARD

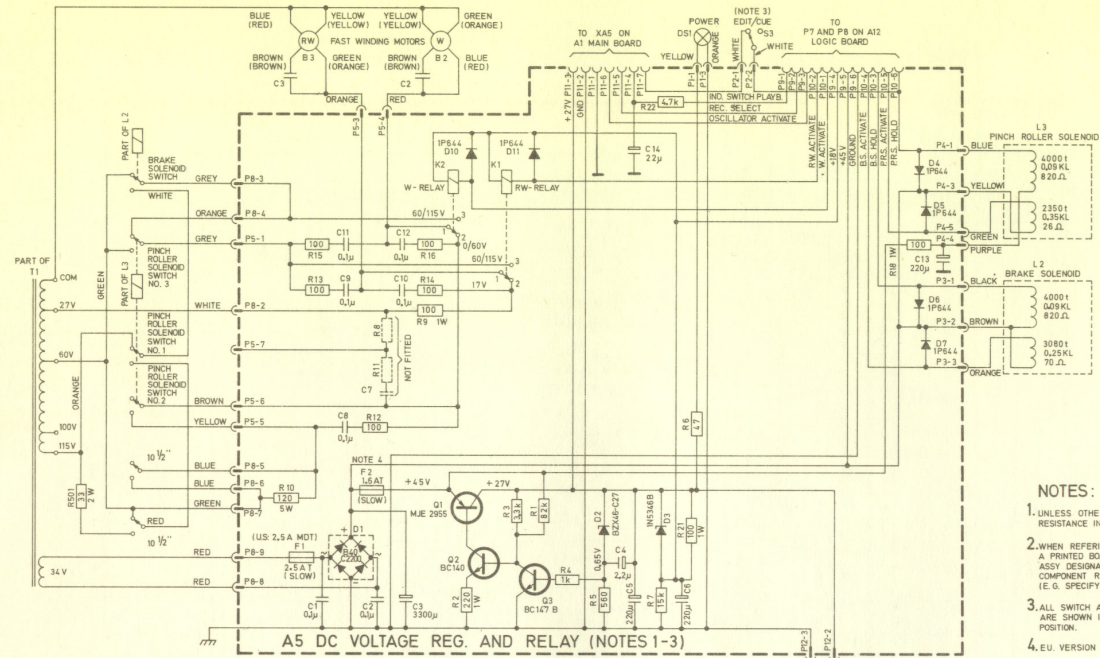

REFERENCE DESIGNATIONS

NO PREFIX	PREFIX WITH A5	NOT USED
B2,3	C1-14	C7
C2,3	D1-7, 11, 12	R9, 11
D1,1	F2	
L2,3	K1,2	
S3,4	P1-5, 8-12	
T1	Q1-7	
	R1-18, 21, 22	

ALTERNATIVE WINDING MOTORS

C2 / C3	R10	NOTES
RO 20 80-4	120Ω	WIRING: ()
1B 953 RA3	5 μF	

- NOTES:
- UNLESS OTHERWISE SPECIFIED RESISTANCE IN OHMS.
 - WHEN REFERRING TO A COMPONENT ON A PRINTED BOARD ASSEMBLY PUT THE ASSY DESIGNATION IN FRONT OF THE COMPONENT REFERENCE DESIGNATION (E.G. SPECIFY A6R1, NOT ONLY R1).
 - ALL SWITCH AND RELAY CONTACTS ARE SHOWN IN THE "POWER OFF" POSITION.
 - EU. VERSION ONLY.

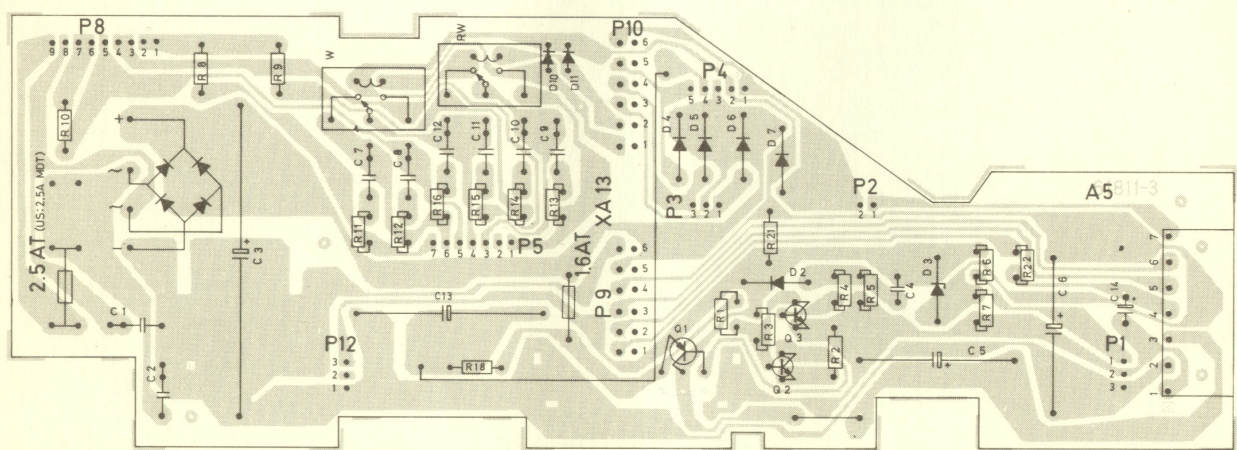

A5 D.C. VOLTAGE REG. AND RELAY CIRCUIT.

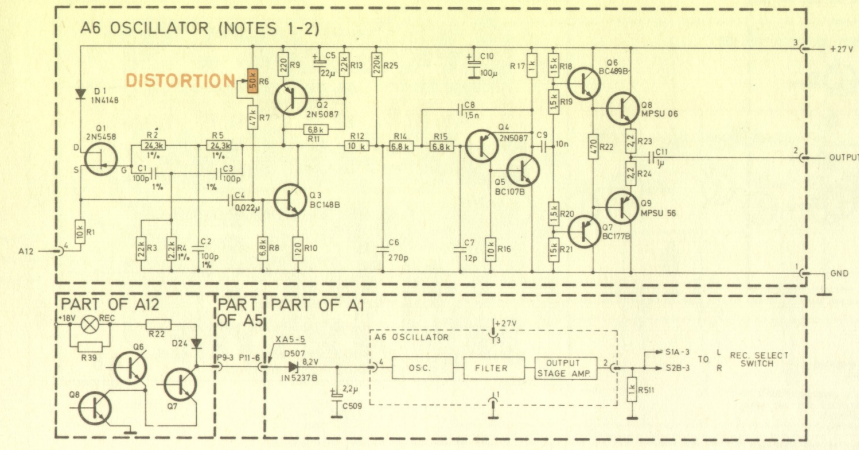

REFERENCE DESIGNATIONS

PREFIX WITH A6	NOT USED
D1-11	
D11-9	
R1-25	

- NOTES:
- UNLESS OTHERWISE SPECIFIED RESISTANCE IN OHMS.
 - WHEN REFERRING TO A COMPONENT ON A PRINTED BOARD ASSEMBLY PUT THE ASSY DESIGNATION IN FRONT OF THE COMPONENT REFERENCE DESIGNATION (E.G. SPECIFY A6R1 AND NOT ONLY R1).

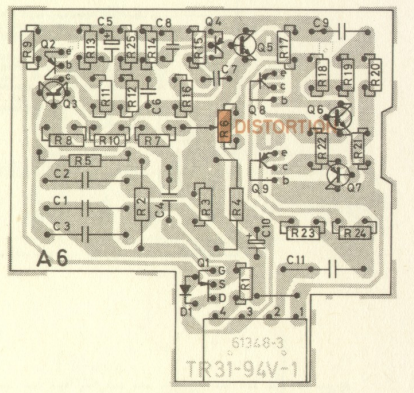

A6 OSCILLATOR BOARD

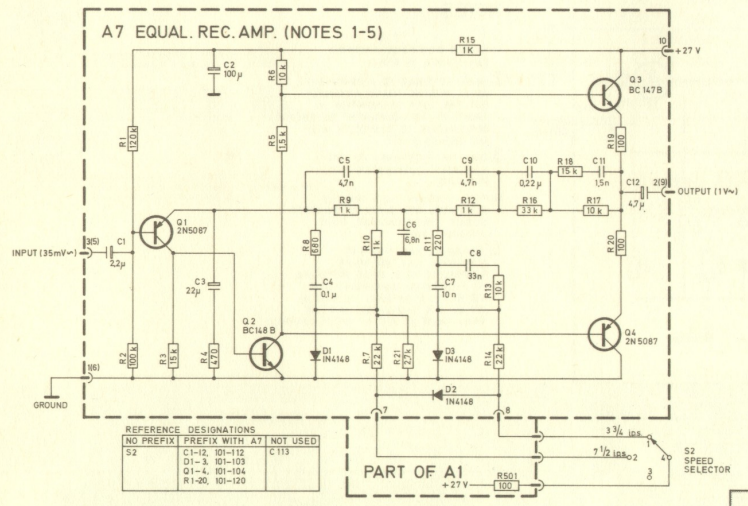

REFERENCE DESIGNATIONS

NO PREFIX	PREFIX WITH A7	NOT USED
S2	C1-12, 10-12	C113
	D1-3, 101-103	
	Q1-4, 101-104	
	R1-20, 101-100	

Modifications.

Component	Value	Changed to:
C4/C104	0.1 μF	0.047 μF
R8/R108	680 ohm	1.5 k ohm
C6/C106	6,8n	3,3n
C7/C107	10n	15n

- NOTES
- UNLESS OTHERWISE SPECIFIED RESISTANCE IN OHMS.
 - WHEN REFERRING TO A COMPONENT ON A PRINTED BOARD ASSEMBLY PUT THE ASSY DESIGNATION IN FRONT OF THE COMPONENT REFERENCE DESIGNATION (E.G. SPECIFY A7R1 AND NOT ONLY R1).
 - ONLY THE L-CHANNEL OF THE ASSEMBLY DESIGNATED A7 IS SHOWN.
 - PLUS TERMINAL NOS FOR THE R-CHANNEL ARE GIVEN IN BRACKETS BESIDE THE L-CHANNEL PLUS TERMINAL NOS.
 - L-CHANNEL HAS 1 R9 AND R-CHANNEL HAS 100-199 AS COMPONENT NOS. WHEN REFERRING TO R-CHANNEL COMPONENTS ADD 100 TO THE L-CHANNEL NOS (E.G. R17 OF THE L-CHANNEL HAS THE SAME VALUE AS R117 OF THE R-CHANNEL).

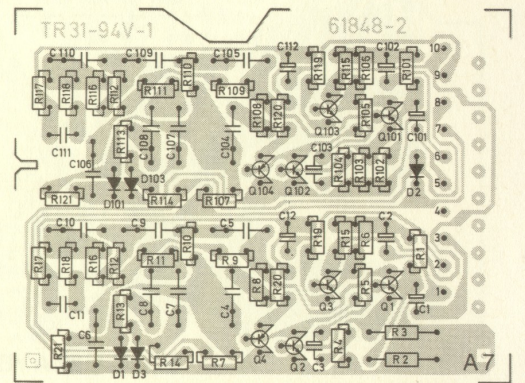

A7 EQUAL REC. AMP.

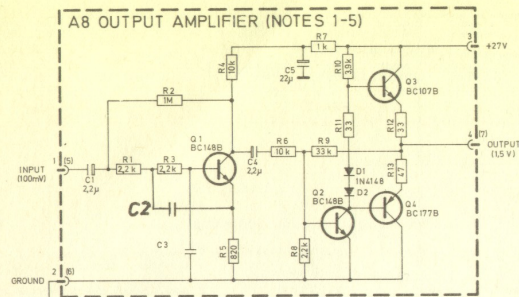

C2 3300pF
C3 1500pF

NOTES:

1. UNLESS OTHERWISE SPECIFIED RESISTANCE IN OHMS.
2. WHEN REFERRING TO A COMPONENT ON A PRINTED BOARD ASSEMBLY PUT THE ASSY DESIGNATION, E.G. SPECIFY A8R1 AND NOT ONLY R1.
3. ONLY THE L-CHANNEL OF THE ASSEMBLY DESIGNATED A8 IS SHOWN.
4. PLUG TERMINAL NO'S FOR THE R-CHANNEL ARE GIVEN IN BRACKETS BESIDE THE L-CHANNEL PLUG TERMINAL NO'S.
5. L-CHANNEL HAS 1-99 AND R-CHANNEL HAS 100-199 AS COMPONENT NO'S. WHEN REFERRING TO R-CHANNEL COMPONENTS, ADD 100 TO THE L-CHANNEL NO'S (E.G. R17 OF THE L-CHANNEL HAS THE SAME VALUE AS R177 OF THE R-CHANNEL).

A8 OUTPUT AMPLIFIER

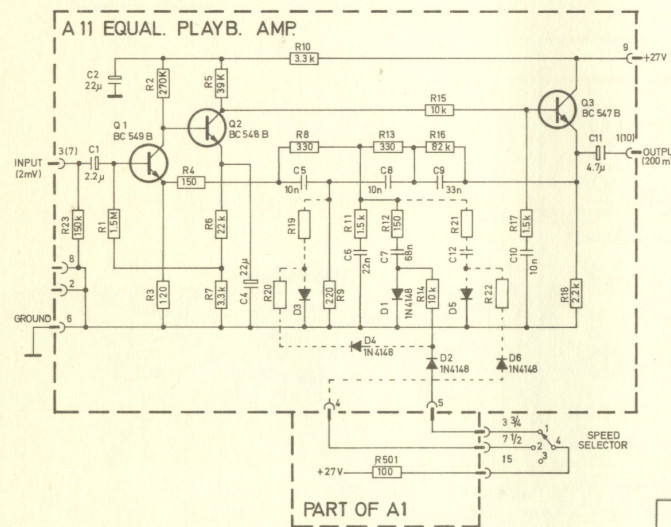
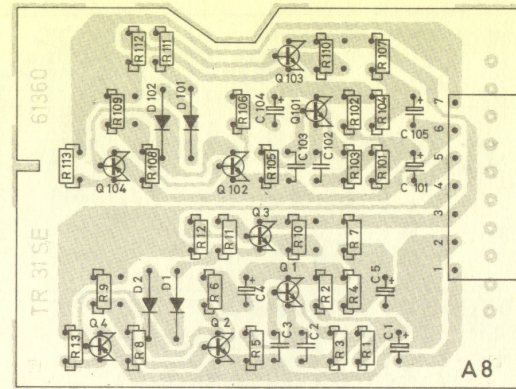

A11 EQUAL PLAYB. AMP.

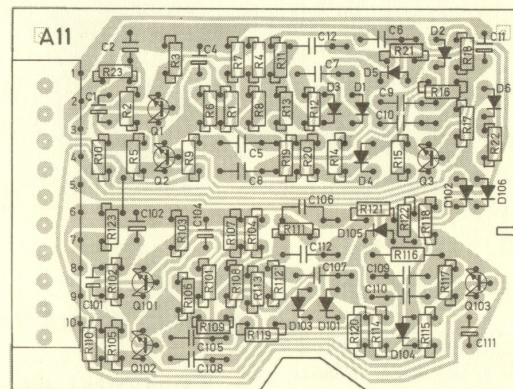

NOTES:

1. UNLESS OTHERWISE SPECIFIED RESISTANCE IN OHMS.
2. WHEN REFERRING TO A COMPONENT ON A PRINTED BOARD ASSEMBLY PUT THE ASSY DESIGNATION IN FRONT OF THE COMPONENT REFERENCE DESIGNATION (E.G. SPECIFY A11R1 AND NOT ONLY R1).
3. ONLY THE L-CHANNEL OF THE ASSEMBLY DESIGNATED A11 IS SHOWN.
4. PLUG TERMINAL NO'S FOR THE R-CHANNEL ARE GIVEN IN BRACKETS BESIDE THE L-CHANNEL PLUG TERMINAL NO'S.
5. L-CHANNEL HAS 1-99 AND R-CHANNEL HAS 100-199 AS COMPONENT NO'S. WHEN REFERRING TO R-CHANNEL COMPONENTS, ADD 100 TO THE L-CHANNEL NO'S (E.G. R17 OF THE L-CHANNEL HAS THE SAME VALUE AS R177 OF THE R-CHANNEL).

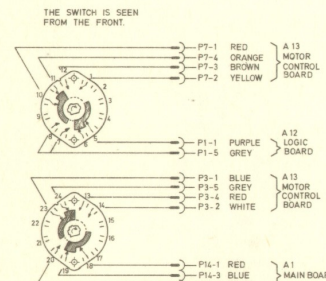
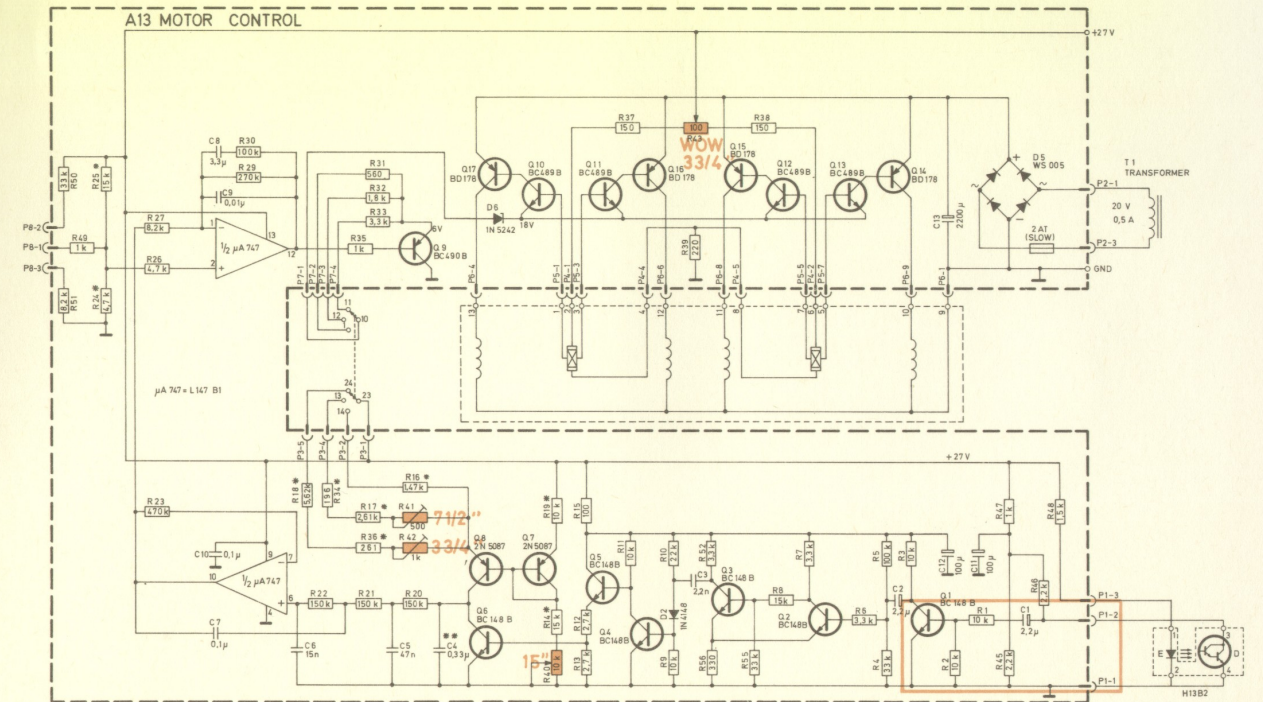

Modifications.

Component	Value	Changed to:
R39	220 ohm	150 ohm, 2W
R37/R38	150 ohm	330 ohm
R32	1.8 k ohm	1.2 k ohm
R33	3.3 k ohm	2.2 k ohm
D6	IN5242	Replace with strap

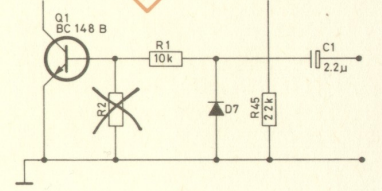

Install D7, 1N4148 between R1 and C1 to ground. R2 removes.

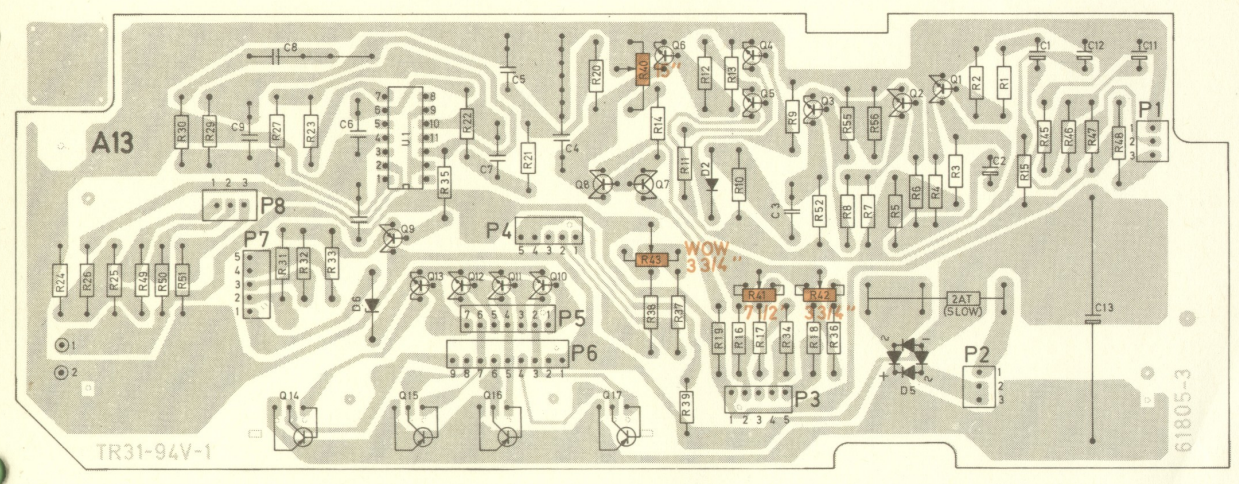

A13 MOTOR CONTROL