

TANDBERG TAPE-RECORDER

MODELS 64 and 62

Service Manual



Tandberg
RADIO

TANDBERGS RADIOFABRIKK A/S - OSLO - NORGE

Preface

This service manual covers the Tandberg tape recorder models 64 and 62.

The Tandberg tape recorder model 64 is a complete quarter-track, three speed stereo recorder and playback unit with three heads. It is equipped with separate amplifiers and cathode followers for each channel.

The Tandberg tape recorder model 62 is the half-track version of the model 64. The two models have the same facilities.

We hope that everyone concerned with our products will find this service manual useful.

December 1963.

This second edition of the service manual has been changed to incorporate certain modifications which have been made in the tape recorder to improve the equipment.

January 1965.

This third edition of the service manual is a re-print of the second edition.

September 1965.

Contents

	Page		Page
1.0 Technical specification, Tandberg tape recorder models 64 and 62	4	5.1.3 The record amplifier	26
2.0 The function of the controls	6	5.1.4 The playback pre-amplifier	27
3.0 The input and output terminals	7	5.1.5 The cathode follower	28
3.0.1 Model 64 and 62, without FM-multiplex filter	7	5.1.6 The record level indicator circuit	28
3.0.2 Model 64 and 62, with FM-multiplex filter	7	5.1.7 The oscillator, bias and erase circuits	28
3.0.3 Microphone inputs	8	5.1.8 The momentary start-stop circuit	29
4.0 The mechanism, detailed description and adjustment instruction	8	5.1.9 The power supply	30
4.1 The operating lever	9	5.2 The switching system, block diagram	31
4.1.1 The motor switch	9	5.2.1 The push-button switch	32
4.1.2 The eccentric segment	10	5.2.2 The S-on-S switch	32
4.1.3 The pressure wheel assembly	10	5.2.3 Monaural recording on channel 1 or 2	32
4.1.4 The tape brake	12	5.2.4 Mixing during monaural recording	32
4.1.5 The mechanical connection for the muting switch ..	12	5.2.5 Stereo recording	32
4.1.6 The trip bar	12	5.2.6 Mixing during stereo recording	33
4.2 The turntable assemblies	13	5.2.7 Monaural playback channel 1 or 2	33
4.2.1 The supply turntable	13	5.2.8 Stereo playback	33
4.2.2 The tape tight tension	13	5.2.9 Add a track	33
4.2.3 The brake for the supply turntable	13	5.2.10 Sound on sound	34
4.2.4 The take-up turntable assembly	14	5.2.11 Echo effects	34
4.2.5 Horizontal and vertical alignments of the turntables	15	5.3 Head alignment and track control with Tandberg test tapes ..	35
4.3 Clutch alignments	15	5.3.1 Model 64	35
4.3.1 General	15	5.3.2 Model 62	35
4.3.2 Fast rewind	16	5.4 Head alignment without Tandberg test tapes	35
4.3.3 Fast wind	16	5.4.1 Demagnetizing	35
4.3.4 Normal forward drive	17	5.4.2 The mounting plate for the heads	35
4.3.5 Neutral	17	5.4.3 The adjustable tape guide	35
4.3.6 Free	18	5.4.4 The playback head	35
4.4 The motor pulley	18	5.4.5 The record head	36
4.4.1 Threading of the rubber drive belt	18	5.4.6 The erase head	36
4.5 The speed transfer wheel	18	5.5 Track control, model 64 without Tandberg test tapes	36
4.6 The lifting arm	19	5.5.1 The record head	36
4.7 The flywheel with the capstan	19	5.5.2 The erase head	36
4.7.1 The brake for the flywheel	20	5.5.3 The playback head	36
4.8 The speed change mechanism	21	5.6 Track control, model 62 without Tandberg test tapes	36
4.9 The momentary start-stop feature	21	5.6.1 The erase head	36
4.10 The pressure pad	22	5.6.2 The record head	36
4.11 The automatic end stop switch	22	5.6.3 The playback head	36
4.12 The revolution counter	22	5.7 Electrical adjustments	37
4.13 Assembling the top cover	23	5.7.1 Adjustments of the oscillator and suppressor coils ..	37
5.0 The electronic circuits, detailed description and adjustment instruction	24	5.7.2 Bias adjustment	37
5.1 The main electronic units, block diagram	24	5.7.3 Adjustment of the recording current, the indicators and the AB-test	37
5.1.1 The record pre-amplifier	24	5.7.4 Adjustment of the FM-multiplex filter	38
5.1.2 The FM-multiplex filter	25	5.7.5 Playback amplifier test	38
		5.7.6 Record amplifier test	38
		5.7.7 Total record and playback response	38
		5.8 Modification of model 64 to model 62	38
		5.9 Introduction of ECC81 (V3 and V4)	39
		5.10 Vertical mounting of models 64 and 62	39
		6.0 Parts list	39
		6.0.1 Mechanical parts	40
		6.0.2 Electrical parts	43

1.0 Technical specification, Tandberg tape recorder models 64 and 62

Power requirements:	110 - 125 - 145 - 200 - 220 - 245 Volts, 50 c/s. U.S. models: 115 Volts, 60 c/s.
Power consumption:	65 watts.
Motor:	Hysteresis synchronous motor.
Tape speeds:	$7\frac{1}{2}$, $3\frac{3}{4}$ and $1\frac{7}{8}$ inches per second. The amplifiers are equalized to conform with N.A.B. standards.
Speed accuracy:	Relative accuracy, repeated playback: $\pm .2\%$ or ± 3.6 seconds in 30 minutes. Absolute speed tolerance: $\pm 1\%$.
Playing time model 64:	Four-track recordings on 1800 ft. of tape: Tape speed $7\frac{1}{2}$ i.p.s.: Stereo 2 \times 48 min. Mono 4 \times 48 min. Tape speed $3\frac{3}{4}$ i.p.s.: Stereo 2 \times 96 min. Mono 4 \times 96 min. Tape speed $1\frac{7}{8}$ i.p.s.: Stereo 2 \times 192 min. Mono 4 \times 192 min.
Playing time model 62:	Two-track recordings on 1800 ft. of tape: Tape speed $7\frac{1}{2}$ i.p.s.: Stereo 48 min. Mono 2 \times 48 min. Tape speed $3\frac{3}{4}$ i.p.s.: Stereo 96 min. Mono 2 \times 96 min. Tape speed $1\frac{7}{8}$ i.p.s.: Stereo 192 min. Mono 2 \times 192 min.
Fast wind and rewind:	The fast wind or rewind time for 1800 feet of tape is approx. $2\frac{1}{2}$ minutes.
Tape path:	The tape moves from left to right. The heads are mounted with the air gaps pointing towards the front.
Recording tape:	Maximum reel diameter is 7". Good quality recording tape is recommended.
Automatic stop:	The automatic stop operates during record or play-back as well as during fast wind or rewind modes.
Remote start-stop:	A connector is provided for connection with a foot control switch.
Heads, model 64:	1 Quarter-track, two channel erase head. 1 Quarter-track, two channel record head. Air gap: 0.013 mm (.0003"). 1 Quarter-track, two channel playback head. Air gap: 0.003 mm (.00012").
Heads, model 62:	1 Half-track, two channel erase head. 1 Half-track, two channel record head. Air gap: 0.013 mm (.0003"). 1 Quarter-track, two channel playback head. Air gap: 0.003 mm (.00012").
Frequency response:	$7\frac{1}{2}$ i.p.s. 30–20 000 c/s (± 2 dB 40–16 000 c/s). $3\frac{3}{4}$ i.p.s. 30–14 000 c/s (± 2 dB 60–10 000 c/s). $1\frac{7}{8}$ i.p.s. 50–7 000 c/s (± 2 dB 80–5 500 c/s).
Distortion:	The distortion from the record amplifiers at maximum recording level is less than .5%. The distortion from the tape recorded with a 400 c/s signal at maximum recording level is less than 3%, when played back. The distortion from the tape recorded with a 400 c/s signal at 10 dB below maximum recording level is less than .5%, when played back.

Signal to noise ratio, model 64:	The signal to noise ratio is better than 53 dB with the tape recorded to 3 % distortion at $7\frac{1}{2}$ i.p.s. tape speed.
Signal to noise ratio, model 62:	The signal to noise ratio is better than 56 dB with the tape recorded to 3 % distortion at $7\frac{1}{2}$ i.p.s. tape speed.
Crosstalk:	The crosstalk rejection is better than 60 dB at 400 c/s.
Wow and flutter:	Better than .1 % RMS at $7\frac{1}{2}$ i.p.s. tape speed. Better than .2 % RMS at $3\frac{3}{4}$ i.p.s. tape speed. Better than .3 % RMS at $1\frac{7}{8}$ i.p.s. tape speed.
Erase and bias frequency:	The erase and bias frequency is 78 kc/s \pm 2 kc/s. The even harmonic distortion in the bias current is less than .5 %.
Recording level indicators:	The electronic beam indicator range is 20 dB plus overload, and is adjusted for maximum indication at 3 % distortion recorded on the tape. The indicators are equipped with damping circuits.
Input impedance:	Microphone input ch. 1 and ch. 2.: Input impedance: 5 Mohm, maximum input voltage: 50 mV. Minimum input signal for maximum recording level at 1000 c/s: 1,5 mV. High level input ch. 1 and ch. 2: Input impedance: 1 Mohm, maximum input voltage: 3 V. Minimum input signal for maximum recording level at 1000 c/s: 50 mV. Low level inputs ch. 1 and ch. 2: Input impedance: 100 kohm, maximum input voltage: 200 mV. Minimum input signal for maximum recording level at 1000 c/s: 4 mV. Note: The low level inputs ch. 1 and ch. 2 are replaced by FM-Multiplex inputs on tape recorders sold in certain territories. FM-multiplex inputs: Input impedance: 85 kohm, maximum input voltage: 2 V. Minimum input signal for maximum recording level at 1000 c/s: 50 mV.
Output:	A tape recorded at 400 c/s to 3 % distortion will give an output of 1.5 V, with the playback volume controls to maximum. The distortion from the playback amplifier is below .2 % when the load impedance is 10 kohm or more, increasing to 2 % distortion at 2 kohm. Minimum load impedance is 2 kohm.
Counter:	The 4 digit counter shows the number of revolutions of the take-up turntable.
Tubes:	4 ECC83 (12AX7), 3 ECC82 (12AU7), 2 ECC81 (12AT7), 2 EAM86.
Rectifiers:	One high voltage selenium rectifier (B250 C75) and one low voltage selenium rectifier (B30 C1000).
Dimensions:	Teak cabinet 16" long, 12" wide and 6" high.
Weight:	Instrument alone 25 lbs, with carrying case 30 lbs.

2.0 The function of the controls:

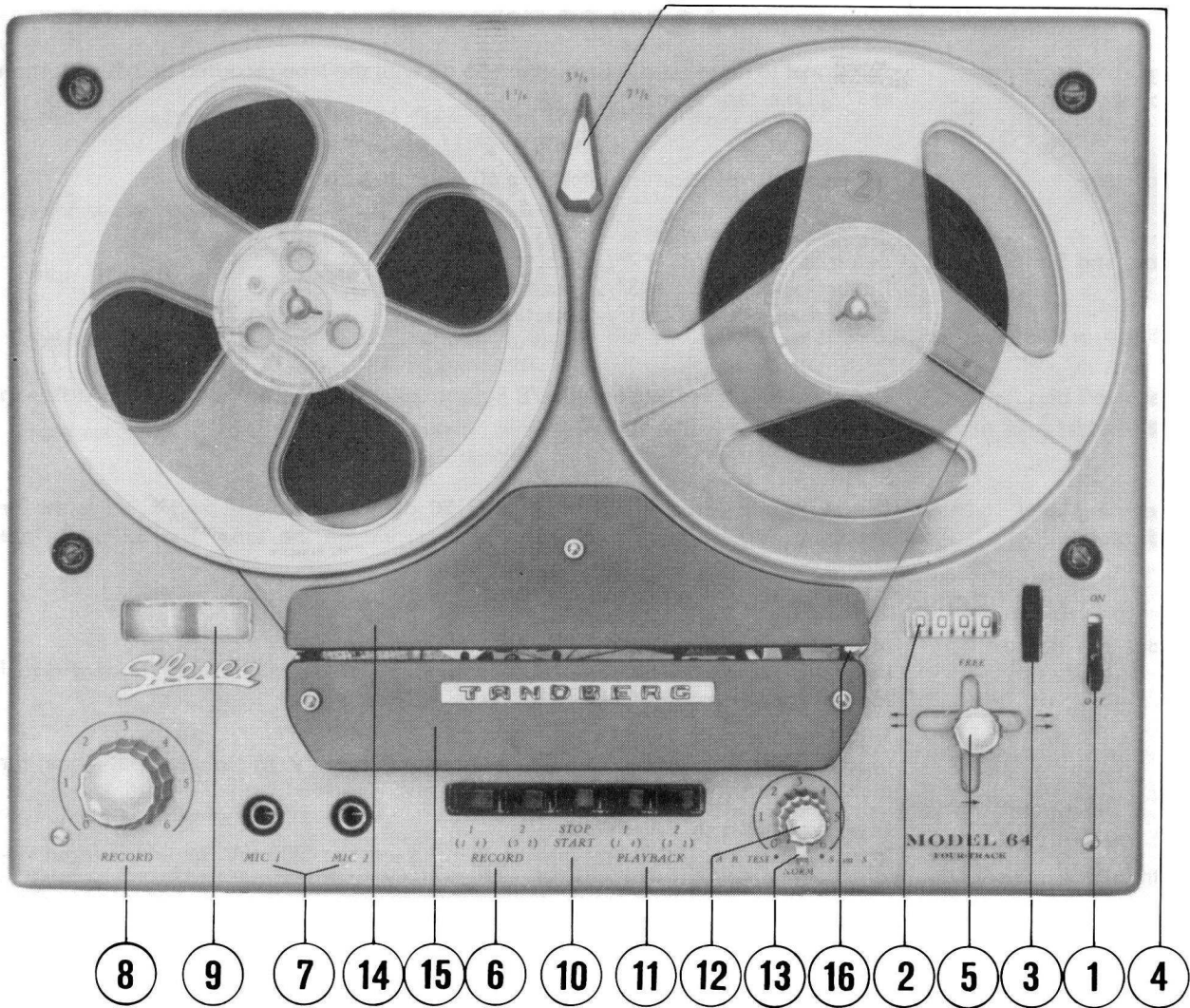

Fig. 1. The operating controls.

- | | |
|---------------------------------|---|
| 1. Power switch: | |
| 2. Tape counter: | indicates the position of the tape. |
| 3. Re-set wheel: | re-sets the tape counter to zero. |
| 4. Speed selector: | selects the desired tape speed. |
| 5. Operating lever: | activates the mechanism in the tape recorder for the different modes of operation. |
| 6. Record push-buttons 1 and 2: | activate the electronic circuits for recording. An interlock system is introduced between the record push-buttons and the operating lever to prevent undesired erasure.
Push button 1: Channel 1.
Push button 2: Channel 2. |
| 7. Microphone inputs: | high impedance microphone inputs.
Mic. 1: Channel 1.
Mic. 2: Channel 2. |
| 8. Record gain controls: | adjust the recording gain of both channels, separately or simultaneously.
Upper knob: Channel 1.
Lower knob: Channel 2. |
| 9. Record level indicators: | indicate the recording level. Maximum recording level is obtained when the electronic beam indicators are closed.
Left indicator: Channel 1.
Right indicator: Channel 2. |
| 10. Start-stop push-button: | starts or stops the tape motion instantly when the operating lever is set to normal forward drive. |

- | | |
|------------------------------------|--|
| 11. Playback push-buttons 1 and 2: | activate the electronic circuits for playback.
Push-button 1: Channel 1.
Push-button 2: Channel 2. |
| 12. Playback volume controls: | provide individual adjustment of both outputs independent of the position of the push-buttons.
Upper knob: Channel 1.
Lower knob: Channel 2. |
| 13. Sound-on-sound switch: | has three positions: S-on-S.
Normal
AB-test. |
| 14. Rear trim cover: | Remove the rear trim cover to clean or demagnetize the heads. |
| 15. Front trim cover: | Remove the front trim cover to clean or demagnetize the heads. |
| 16. Automatic end stop switch: | shuts off the motor when the tape runs out or if the tape breaks. |

3.0 The input and output terminals

3.0.1 Model 64 and 62, without FM-multiplex filters

The input and output terminals, together with the connector for the remote control, are located at the rear of the tape recorder, ref. fig. 2.

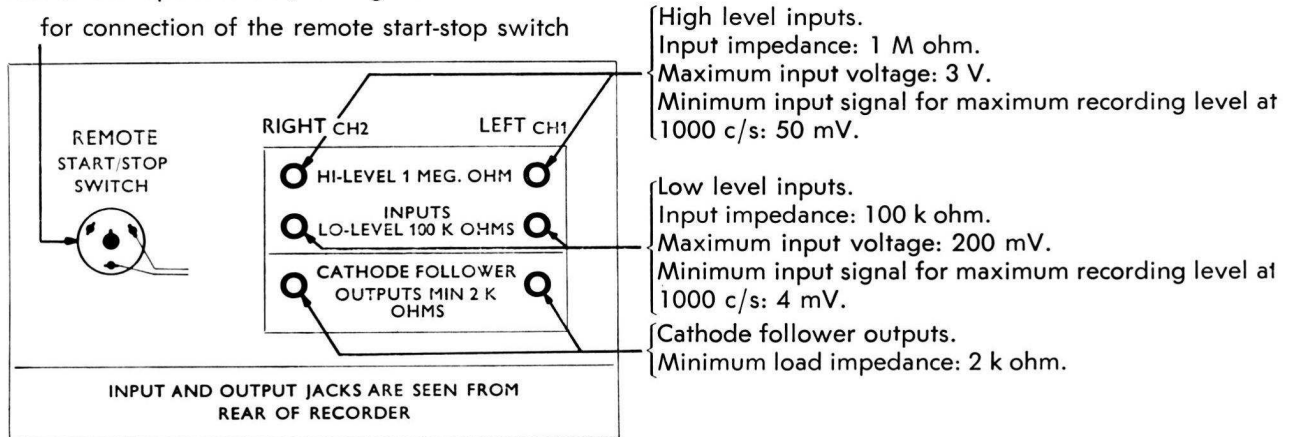

Fig. 2. The input and output terminals, model 64 and 62, without FM-multiplex filter.

3.0.2 Model 64 and 62, with FM-multiplex filters

The low level inputs ch. 1 and ch. 2 are replaced by FM-multiplex inputs on tape recorders sold in certain territories. Ref. fig. 3.

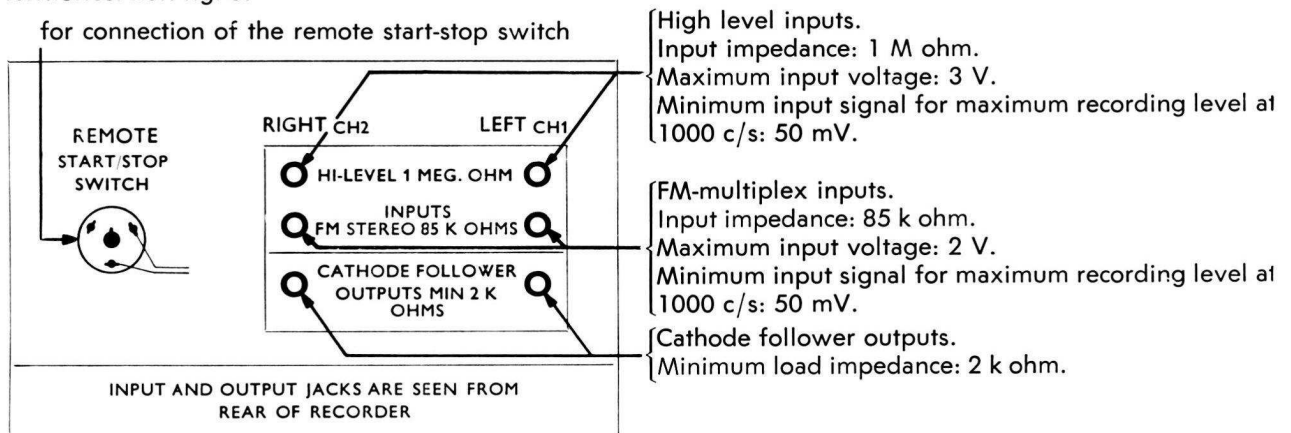

Fig. 3. The input and output terminals, model 64 and 62 with FM-multiplex filter.

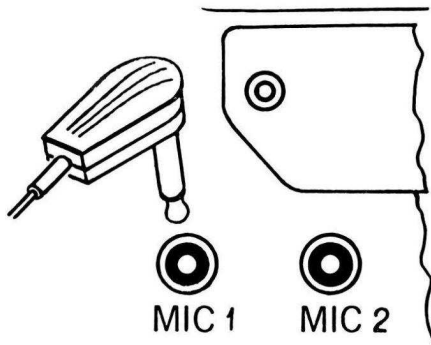

Fig. 4. The microphone inputs.

3.0.3 Microphone inputs

The microphone jacks are located below the front trim cover on top of the recorder. Ref. fig. 4.

Microphone inputs.

Input impedance: 5 M ohm.

Maximum input voltage: 50 mV.

Minimum input signal for maximum recording level at 1000 c/s: 1,5 mV.

Mic. 1: Channel 1.

Mic. 2: Channel 2.

4.0 The mechanism, detailed description and adjustment instruction

The main function of the mechanical system is to drive the turntables and the capstan in the different modes

of tape motion. The mechanical function is activated by the operating lever.

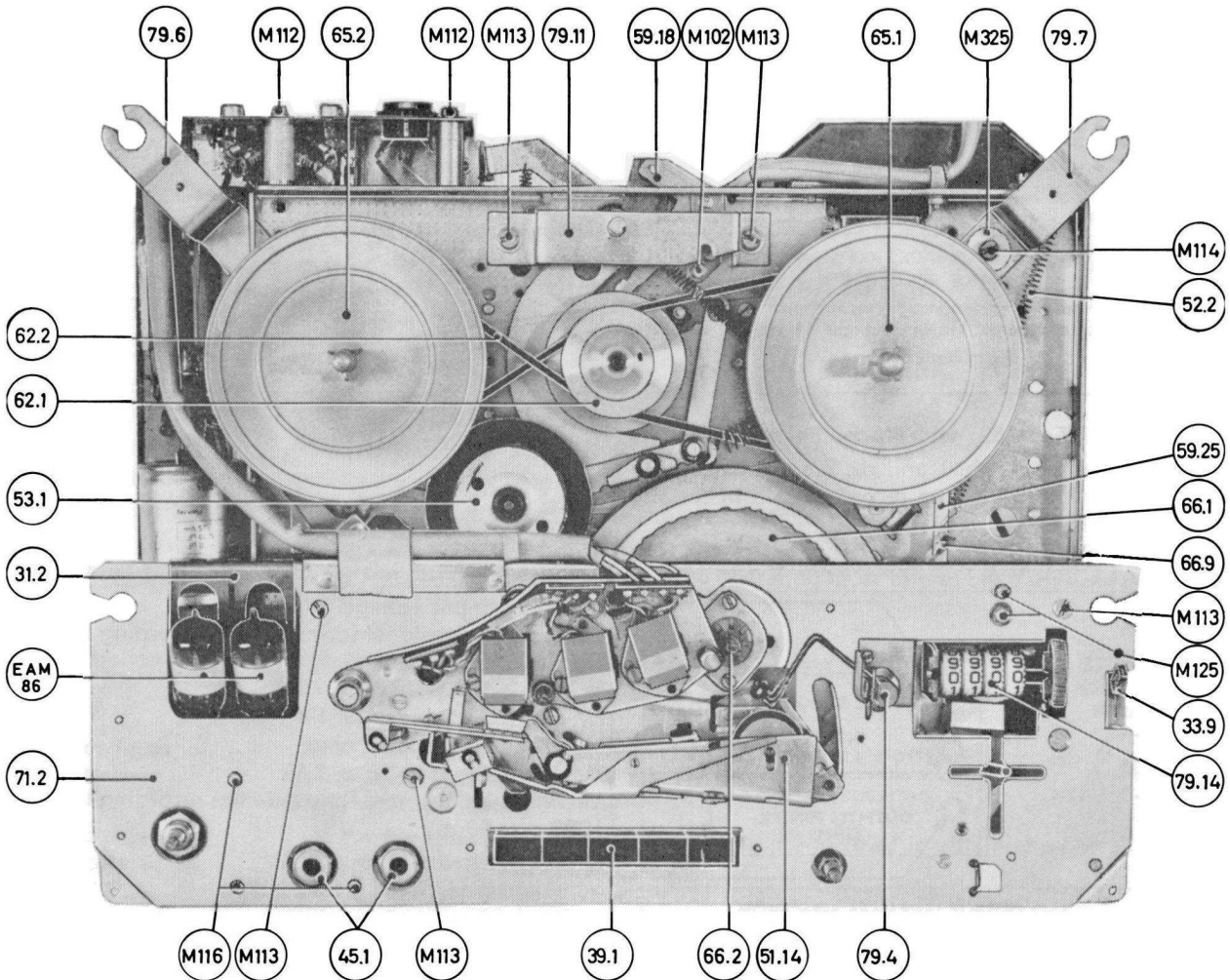

Fig. 5. Top view.

4.1 THE OPERATING LEVER

The operating lever (54.1) has five positions and is located at the right front corner of the tape recorder: Normal forward drive, fast forward drive, fast rewind, free, and neutral. (Ref. fig. 6.)

The operating lever activates the following parts:

The motor switch (33.5): connects the power to the motor (14.1) in normal forward drive, fast wind or fast rewind positions of the operating lever.

The eccentric segment (59.1): guides the pressure wheel assembly (51.3) and the lifting arm (59.25).

The trip bar (52.1): activates the clutches under the turntables (65.7, 65.2) and the brake (59.28) under the supply turntable (65.2).

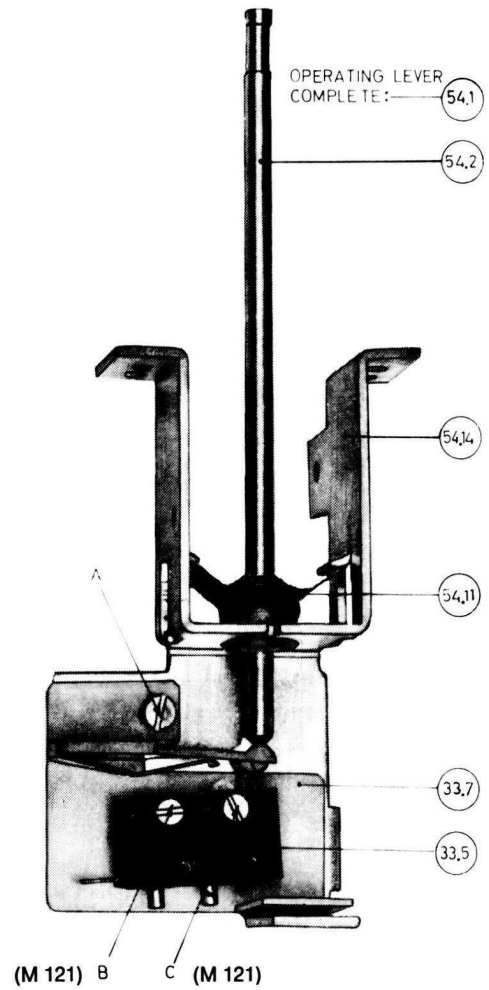

Fig. 6. The operating lever.

4.1.1 The motor switch

The microswitch (33.5) is located on the bracket for the operating lever (54.14) ref. fig. 6. The switch is connected in series with the motor current and is activated by the operating lever (54.1) to shut off the motor in neutral or free position.

Adjustments:

The operating point of the microswitch (33.5) should be set according to fig. 7. The motor should start when the operating lever (54.1) is moved from neutral to either normal forward, fast wind, or fast rewind position. Unscrew the three screws A, B, and C ref. fig. 6. Adjust the horizontal position of the delrin bracket (33.7) and the vertical position of the microswitch (33.5) obtaining proper positions for correct operating points.

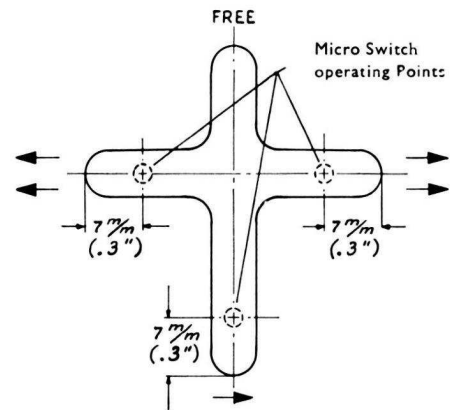

Fig. 7. Adjustment of operating points for the microswitch.

4.1.2 The eccentric segment

The eccentric segment (59.1) is located underneath the upper mounting plate (71.2) and is linked to the operating lever (54.1). Ref. fig. 8.

The eccentric segment (59.1) moves the pressure wheel (51.1) against the capstan (66.2) when the operating

lever (54.1) is being set to normal forward drive.

The lifting arm (59.25) is linked to the eccentric segment (59.1) and releases the speed transfer wheel (53.1) from contacting the motor pulley (62.1) in all operating modes, except in the normal forward drive position.

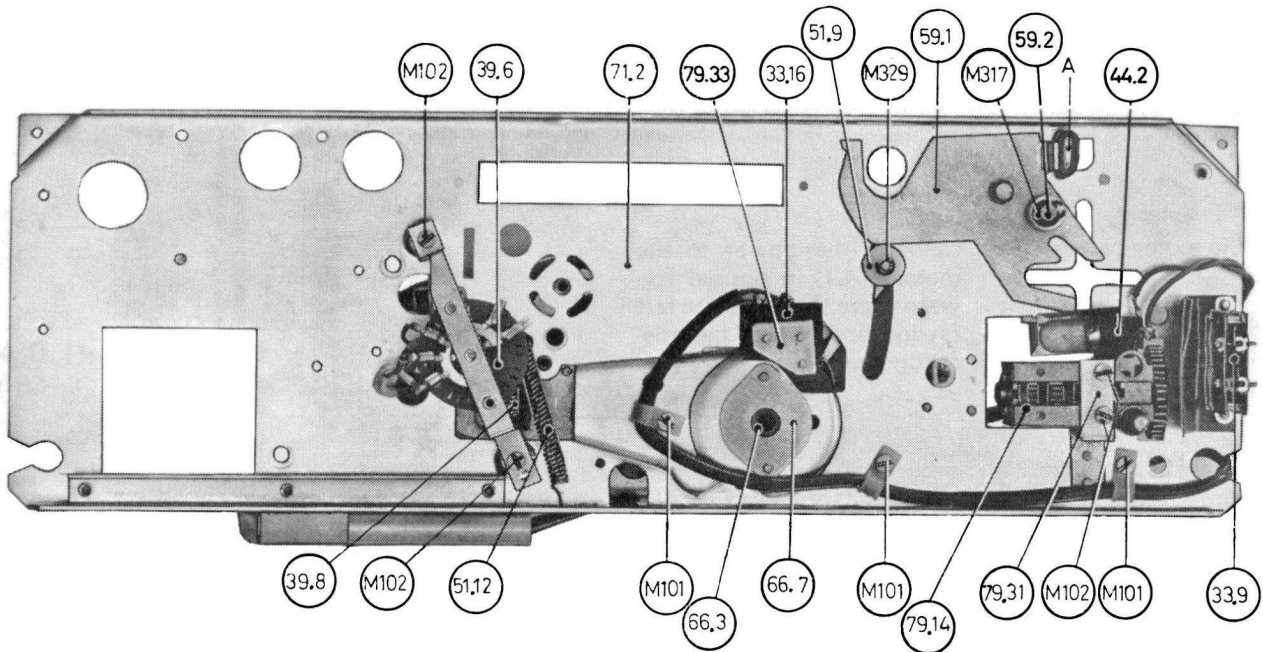

Fig. 8. The upper mounting plate, bottom view.

Adjustments:

Adjust the return motion of the pressure wheel assembly (51.3) by bending the lug (A) ref. fig. 8 to as-

certain easy threading of the tape in the slot between the two trim covers (73.1, 73.2). The tape should not stick against the pressure wheel (51.1) during the threading.

4.1.3 The pressure wheel Assembly

The pressure wheel assembly (51.3) is guided into operating position by the eccentric segment (59.1) when the operating lever (54.1) is moved to normal forward drive.

The pressure wheel (51.1) is mounted under balanced spring tension, with the pressure wheel shaft (51.2) running through two oblong slots in the pressure wheel bracket (51.14). The mounting will allow the pressure wheel (51.1) a horizontal springloaded play of approx. 6 mm (1/4"), on a line perpendicular to the front of the upper mounting plate (71.2). Ref. fig. 9.

Adjustments:

The balanced spring tension of the pressure wheel (51.1) is adjusted to obtain uniform pressure of the pressure wheel against the capstan. Loosen screw E, (M 120), and turn the spring equalization latch (51.7) clockwise or counter clockwise until the tape runs smoothly by the pressure wheel (51.1) in normal forward drive. Make sure that no air-pockets are formed between the tape and the pressure wheel (51.1), and that the tape is completely covered by the rubber surface of the pressure wheel. Ref. fig. 9 and 10.

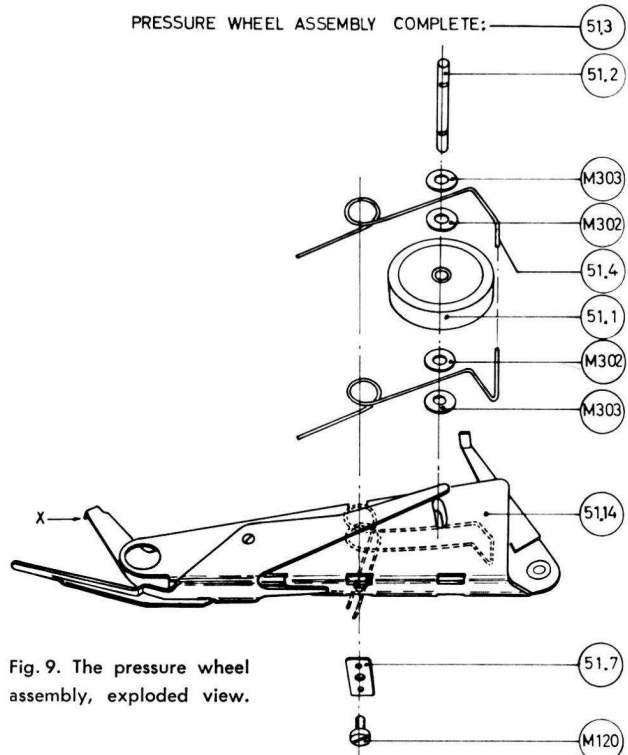

Fig. 9. The pressure wheel assembly, exploded view.

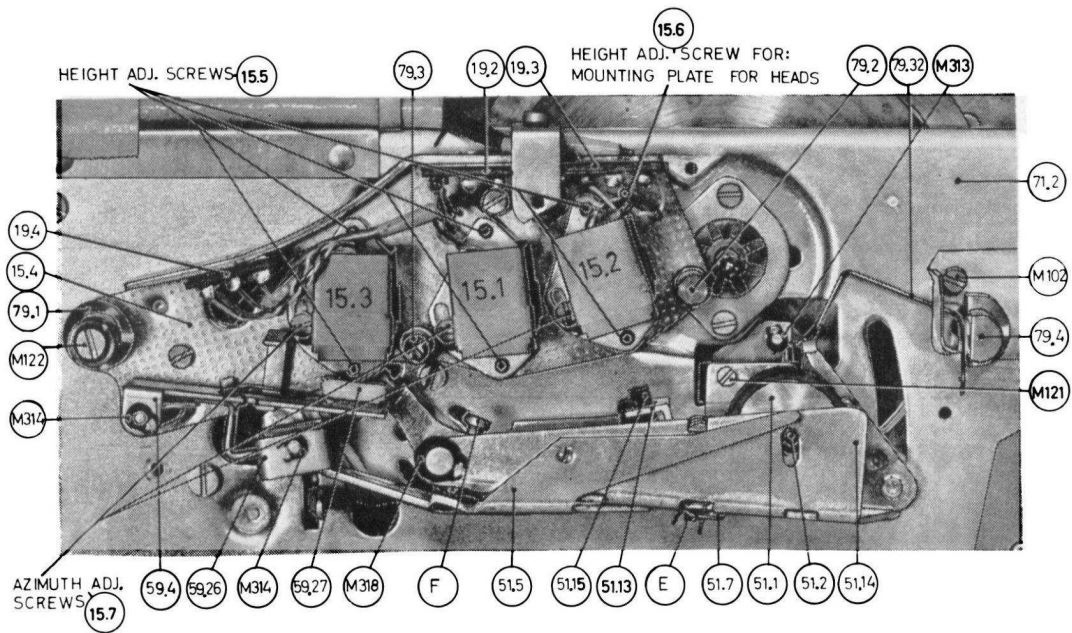

Fig. 10. The mounting plate for the heads with the pressure wheel assembly.

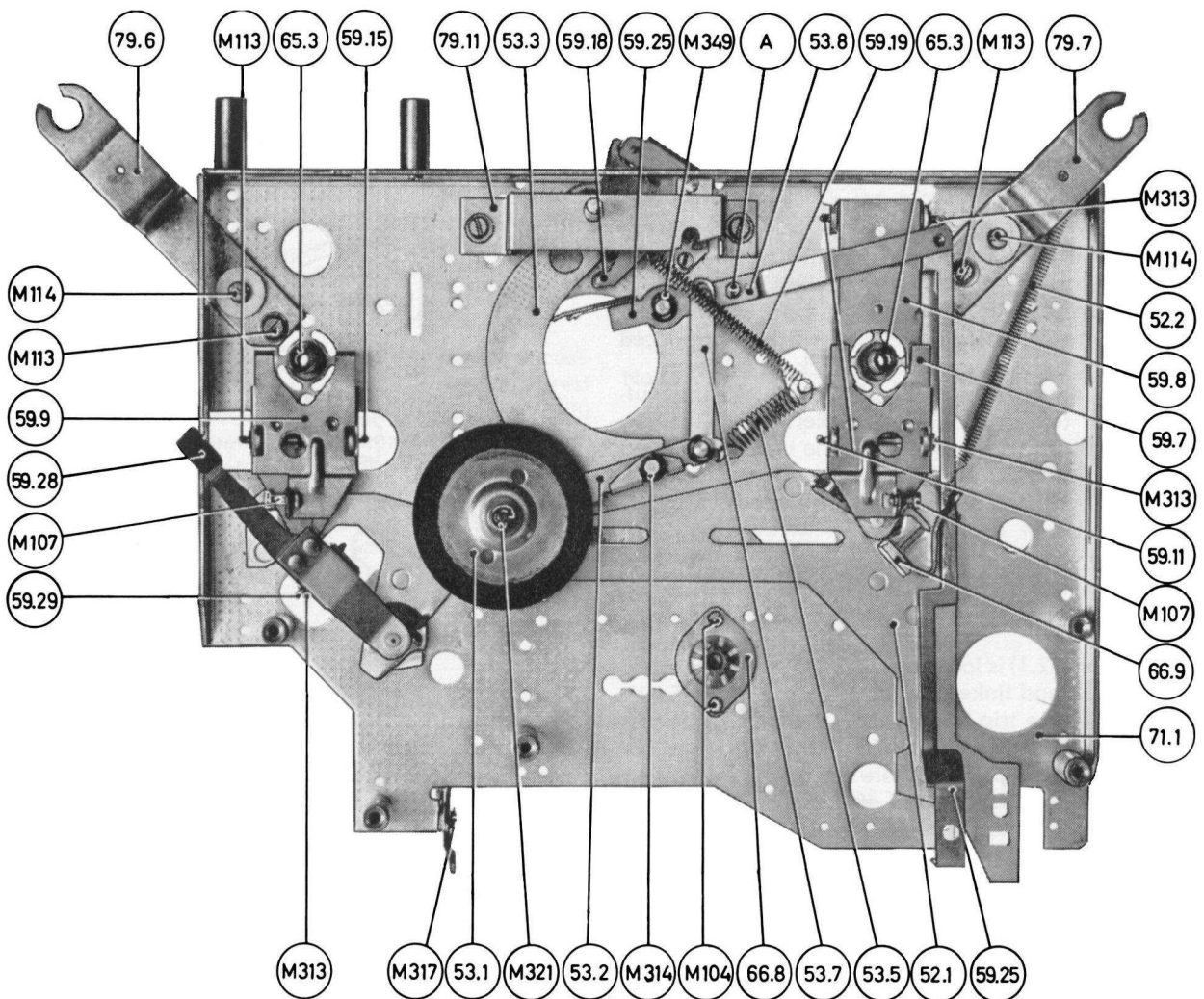

Fig. 11. The lower mounting plate.

4.1.4 The tape brake

The tape brake (51.13) is located inside the pressure wheel assembly (51.3) and is activated by the pressure wheel lever (51.5). Ref. fig. 10. The tape brake (51.13) prevents the tape from creeping when the operating lever (54.1) is in normal forward drive position with the start-stop push-button in stop position (released).

Adjustments:

Set the operating lever (54.1) to normal forward drive and the start-stop push-button to the stop position (released), with tape inserted. The tape brake (51.13) should prevent the tape from creeping when the pressure pad arm (59.4) is pulled away from the erase head.

Start the mechanism by depressing the start-stop push-button. The tape brake (51.13) should be completely disengaged. Adjust the screw F (ref. fig. 10) until the spacing between the tape brake (51.13) and the playback head is approx. 2 mm (.08").

4.1.5 The mechanical connection for the muting switch

The muting switch (39.6) is located above the start-stop magnet (31.1) between the upper and the lower mounting plates (71.2, 71.1). Ref. fig. 8. The muting switch (39.6) shortcircuits both playback pre-amplifier outputs to ground in all positions of the operating lever except normal forward drive. The switch is introduced to prevent noise from the playback amplifiers.

The pressure wheel assembly (51.3) activates the muting switch (89.6) by the lug X. Ref. fig. 9. The lug enters through an oblong slot in the upper mounting plate (71.2) in front of the erase head.

4.1.6 The trip bar

The trip bar (52.1) is located across the lower mounting plate (71.1), and linked to the operating lever (54.1). Ref. fig. 11. The trip bar activates the clutches underneath both turntables (65.1, 65.2) and the brake underneath the supply turntable (59.28) by a sliding motion. The vertical position of the two clutches and the brake are determined by the raised areas of the trip bar (52.1).

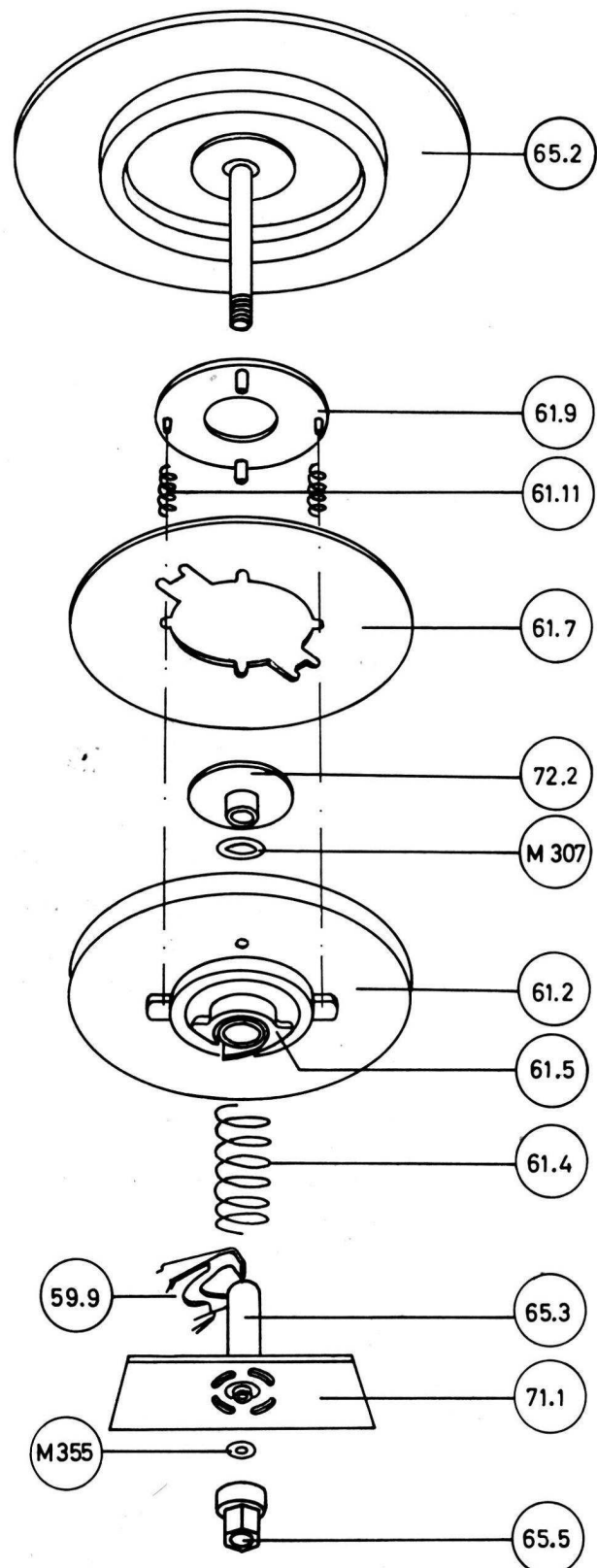

Fig. 12. The supply turntable assembly, exploded view.

4.2 THE TURNTABLE ASSEMBLIES

The design of the turntable assemblies is shown in fig. 12 and 15. The turntable assemblies are built up around the two housings for the turntable bearings (65.3). The housings for the turntable bearings (65.3) are riveted to the lower mounting plate (71.1).

4.2.1 The supply turntable assembly

The supply turntable assembly is put together by first inserting the helical compression spring (61.4) and the pulley disc (61.2) over the housing (65.3). Make sure the compression spring (61.4) fits into the cylindrical groove in the cartridge (61.5). The two delrin lugs and the tongue on the cartridge (61.5) should lie on a line perpendicular to the front edge of the upper mounting plate (71.2), with the delrin tongue pointing towards the front. Press down the pulley disc (61.2) until the delrin lugs on the cartridge (61.5) have passed through the notch in the clutch lever (59.9). Turn the cartridge (61.5) 90° counter clockwise. Make sure that the two delrin lugs have been locked in position by the claws on the clutch lever (59.9), and that the tongue on the cartridge (61.5) fits into the groove in the clutch lever (59.9). Ref. fig. 12 and 13.

Insert the flange for the turntable housing (72.2) by pressing it into the upper end of the housing (65.3). Place the Mylar Sheet (61.7) on the top of the pulley disc (61.2) and insert the two springs (61.11) in the wells. Attach the tape tight disc (61.9) with the short pins inside the two springs (61.11) and insert the turntable (65.2). Ref. fig. 14.

Move the operating lever (54.1) to the fast wind position. This will allow the supply turntable (65.2) to rest on the flange (72.2). Insert one teflon washer (M348) and a suitable number of turbax washers (M355) on the turntable shaft, under the lower mounting plate (71.1), before the delrin nut (65.5) is attached. Ascertain an axial play in the turntable shaft of approx. 0.1 mm (.04").

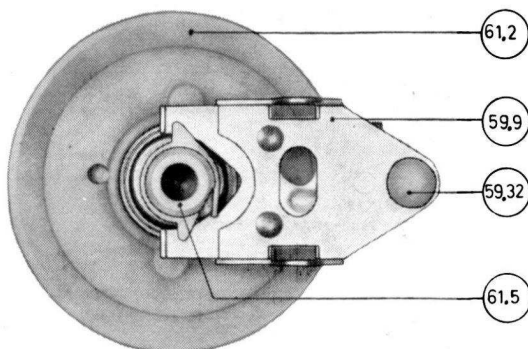

Fig. 13. The supply pulley disc with clutch lever.

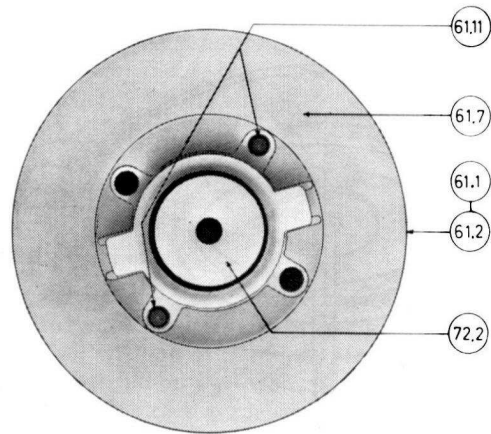

Fig. 14. The supply pulley disc with mylar sheet.

4.2.2 The tape tight tension

A slight permanent clockwise torque of the supply turntable (65.2) has been introduced to prevent a tape loop from being formed between the supply turntable (65.2) and the trim covers (73.1, 73.2) when the operating lever is in normal forward drive, and the start-stop push-button is operated. The tape tight disc (61.9) is a spring loaded friction disc that presses against a round piece of green felt underneath the supply turntable (65.2). Ref. fig. 12.

Adjustments:

The adjustment is made by stretching or cutting the two springs (61.11). The torque should be just sufficient to take up the loop formed when the operating lever is in normal forward drive, and the tape recorder stopped by releasing the start-stop push-button. The tape recorder should be loaded with a full 7" tape reel on the supply turntable (65.3).

Note: Do not increase this torque unnecessarily, as excessive torque might introduce wow and flutter.

4.2.3 The brake for the supply turntable

The brake (59.28) is located under the supply turntable (65.2) and is introduced to prevent eventual creeping of the tape when the operating lever is moved from normal forward drive to neutral position. Ref. fig. 11.

Adjustments:

The braking action should be smooth, without any tendency of backlash at the take-up turntable (65.1), when the operating lever (54.1) is moved from fast rewind to neutral position. Decrease the braking action by bending down the hard brass lever on the brake (59.28) if backlash occurs at the take-up turntable. Make sure that the brake is engaged in neutral position.

Note: The brake should be operative only on tape recorders equipped with Papst motors.

4.2.4 The take-up turntable assembly

The take-up turntable assembly is put together by first inserting the helical compression spring (61.3) and the pulley disc (61.1) over the housing (65.3). Make sure the compression spring (61.3) fits into the cylindrical groove in the cartridge (61.5). The two delrin lugs and the tongue on the cartridge (61.5) should lie on a line perpendicular to the front edge of the upper mounting plate (71.2), with the delrin tongue pointing at the rear edge of the lower mounting plate (71.1). Press down the pulley disc (61.1) until the delrin lugs on the cartridge (61.5) have passed through the notch in the upper clutch lever (59.7). Press the lower clutch lever (59.8) all the way down by using a screw driver. The space between the two clutch levers (59.7, 59.8) will now be approx. 6 mm ($1/4''$). Turn the cartridge (61.5) 90° clockwise, and make sure that the two delrin lugs have been locked in position by the claws on the lower clutch lever (59.8). Ref. fig. 15 and 16.

Insert the flange for the turntable housing (72.1) by pressing it into the upper end of the housing (65.3). Place the mylar sheet (61.6) on the top of the friction disc (61.1) and insert the turntable (65.1). Move the operating lever (54.1) to the fast rewind position. This will allow the take-up turntable (65.1) to rest on the flange (72.1). Insert one teflon washer (M355) on the turntable shaft, under the lower mounting plate (71.1) before the pulley (69.1) is attached. Ascertain an axial play of the turntable shaft of approx. 0.1 mm (.04").

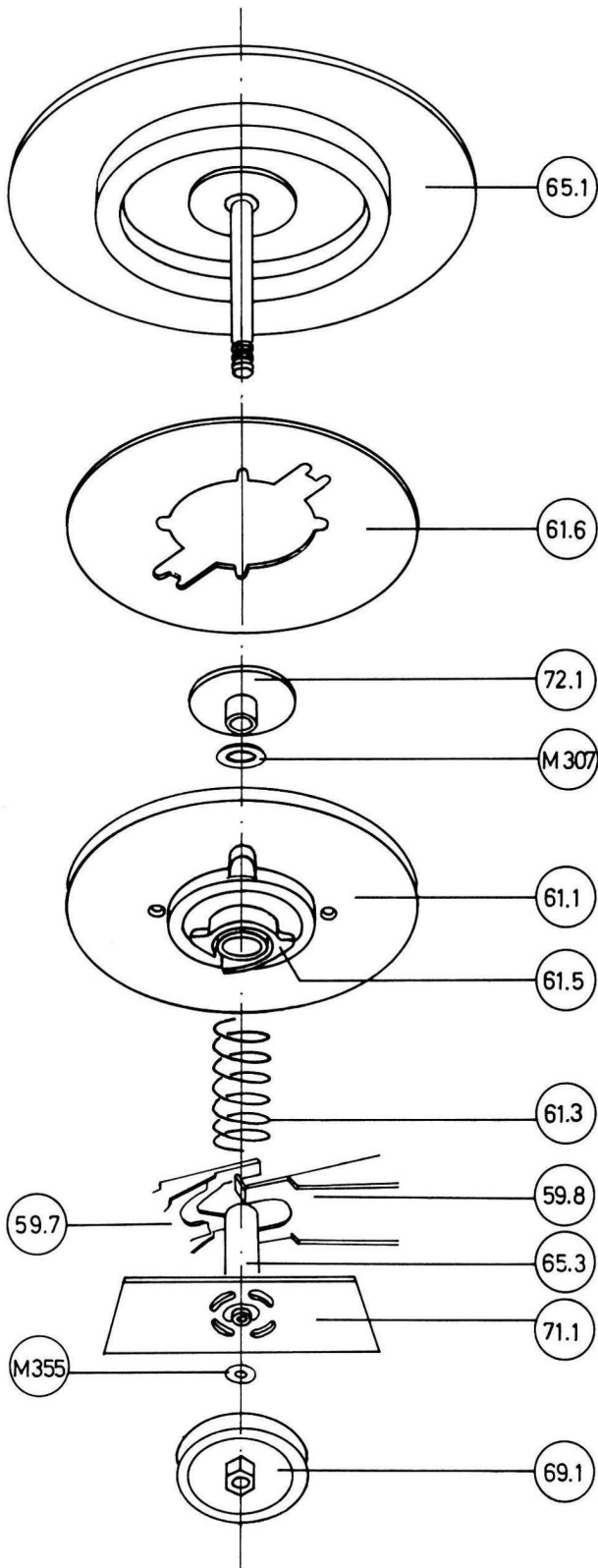

Fig. 15. The take-up turntable assembly, exploded view.

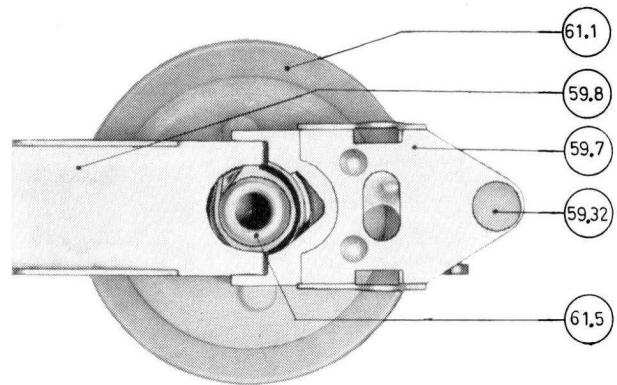

Fig. 16. The take-up pulley disc with clutch levers.

4.2.5 Horizontal and vertical alignments of the turntables

Use the special tools 1, 2, and 3 for these alignments. Ref. fig. 62.

Horizontal alignments

The horizontal position of the two turntables (65.1, 65.2) parallel to the lower mounting plate (71.1) is checked by placing the special tool No. 1 across both turntables as shown in fig. 17. There should be no spacing between the ruler (tool No. 1) and the turntables.

Necessary adjustments are made by bending the turntable housings in correct position. Use the special tool No. 3 as shown in fig. 18.

The horizontal position of both turntables (65.1, 65.2) parallel to a line perpendicular to the front edge of the upper mounting plate (71.2) is checked by using the special tool No. 2.

The edge of the tool No. 2 should run exactly into the

tape groove in the tape guide (79.1, 79.7), when the operating lever (54.1) is in the neutral position. Ref. fig. 19.

Necessary adjustments are made by bending the turntable housing (65.3) in correct position. Use special tool No. 3, as shown in fig. 18.

Vertical alignments

The horizontal position of the turntables must be set before the vertical alignment is made.

The vertical position of the turntables is checked with the tape threaded on the recorder. The tape should not touch the edges of the plastic reels in any mode of operation.

The turntables are raised or lowered, if necessary, by adding or subtracting turbax washers (M306-7) between the flange for the turntable housing (72.1, 72.2) and the turntable housing (65.3). Ref. fig. 12 and 15. A final check of the horizontal position of the turntables should be made.

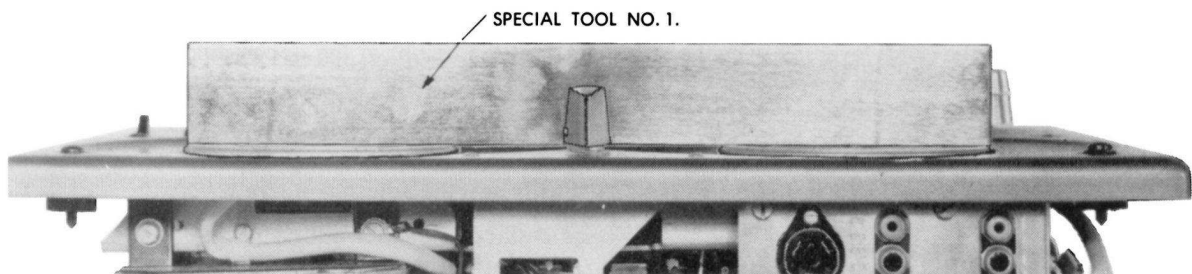

Fig. 17. Control of the horizontal position of the turntables with tool No. 1.

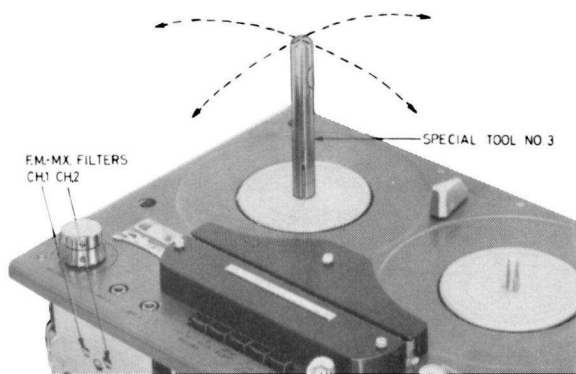

Fig. 18. Alignment of the horizontal position of the turntables with tool No. 3.



Fig. 19. Control of the horizontal position of the turntables with tool No. 2.

4.3 CLUTCH ALIGNMENTS

4.3.1 General

The motor will always run and drive both pulley discs (61.1, 61.2) when the operating lever (54.1) is set to either normal forward drive, fast wind, or fast rewind position. The two pulley discs will run in the opposite directions caused by the cross threading of the rubber drive belt (62.2). Ref. fig. 5.

The torque of the turntables (65.1, 65.2) is obtained by the friction between the pulley discs (61.1, 61.2) and the feltrings glued to the turntables (65.1, 65.2). The friction between the pulley discs and the turntables is determined by the position of the clutches mounted under each pulley disc. The clutches are operated by the trip bar (52.1), which is connected to the operating lever (54.1).

4.3.2 Fast rewind:

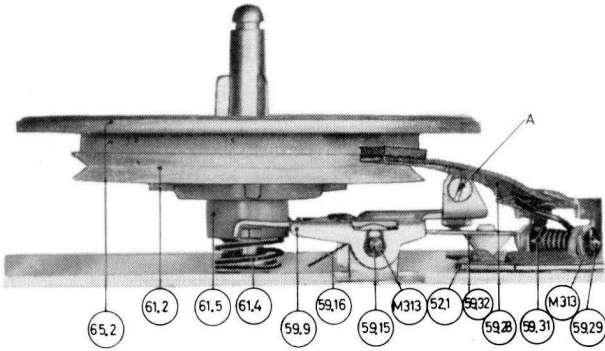

Fig. 20.

The supply turntable

The supply turntable (65.2) has maximum obtainable friction with the pulley disc (61.2) in this position.

The pulley disc (61.2) is pressed against the turntable (65.2) by the entire tension of the compression spring (61.4).

The trip bar (52.1) has moved, and the delrin button (59.32) on the clutch lever (59.9) is at the lowest position. The two delrin lugs on the cartridge (61.5) and the clutch lever (59.9) are disengaged.

Adjustments:

Adjust the height of the clutch lever (59.9) by the screw (A) until the clearance between the clutch lever (59.9) and the delrin lugs on the cartridge (61.5) is approx. 0.5–1 mm (.02"–.04").

The torque of the supply turntable (65.2) should be min. 75 g ($2\frac{3}{4}$ OZ) acting on an arm of 8 cm ($3\frac{1}{2}$ "). Recheck all other positions of the operating lever and finally seal the adjustment screw.

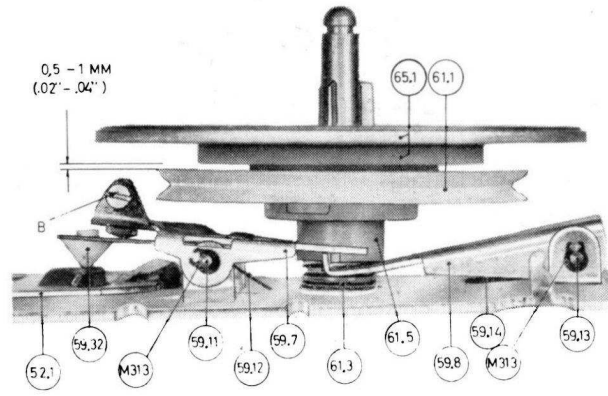

Fig. 21.

The take-up turntable

The take-up turntable (65.1) is completely disengaged from the pulley disc (61.1) and free-running in this position.

The trip bar (52.1) has moved, and the delrin button (59.32) on the upper clutch lever (59.7) is at the highest position, pressing down both the lower clutch lever (59.8) and the two delrin lugs on the cartridge (61.5).

Adjustments:

Adjust the height of the upper clutch lever (59.7) by the screw (B) until the clearance between the pulley disc (61.1) and the feltring on the turntable (65.1) is approx. 0.5–1 mm (.02"–.04").

Recheck all other positions of the operating lever and finally seal the adjustment screw.

4.3.3 Fast wind

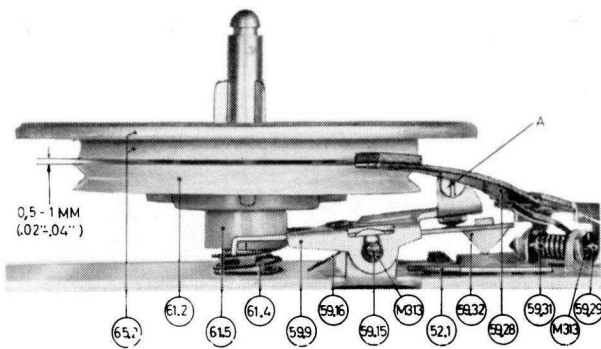

Fig. 22.

The supply turntable

The supply turntable (65.2) is completely disengaged from the pulley disc (61.2) and free running in this position.

The trip bar (52.1) has moved, and the delrin button (59.32) on the clutch lever (59.9) is at the highest position, pressing down the two delrin lugs on the cartridge (61.5).

Adjustments:

Adjust the height of the clutch lever (59.9) by the screw (A) until the clearance between the pulley disc (61.2) and the feltring on the turntable (65.2) is approx. 0.5–1 mm (.02"–.04").

Recheck all other positions of the operating lever and finally seal the adjustment screw.

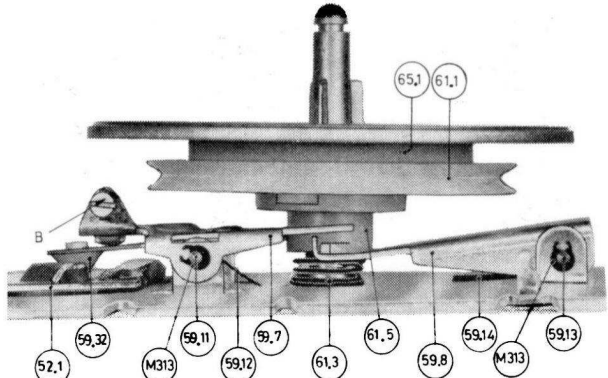

Fig. 23.

The take-up turntable

The take-up turntable (65.1) has maximum obtainable friction with the pulley disc (61.1) in this position. The springloaded lower clutch lever (59.8) is pressing the delrin lugs on the cartridge (61.5) upwards in addition to the entire tension of the compression spring (61.3). The trip bar (52.1) has moved, and the delrin button (59.32) on the upper clutch lever (59.7) is at the lowest position, disengaged from the lower clutch lever (59.8) and the two delrin lugs on the cartridge (61.5).

Adjustments:

Adjust the height of the upper clutch lever (59.7) by the screw (B) until the clearance between the upper and the lower clutch levers (59.7, 59.8) is approx. 0.5 mm (.02").

The torque of the take-up turntable (65.1) should be min. 65 g ($2\frac{1}{4}$ OZ) acting on an arm of 8 cm ($3\frac{1}{2}$ "). Recheck all other positions of the operating lever and finally seal the adjustment screw.

4.3.4 Normal forward drive

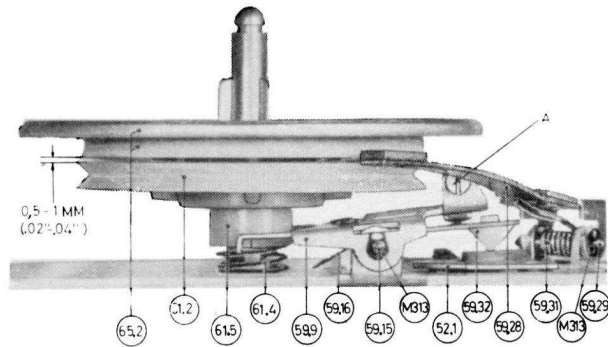

Fig. 24.

The supply turntable

The supply turntable (65.2) is completely disengaged from the pulley disc (61.2) and free-running in this position.

The trip bar (52.1) has moved, and the delrin button (59.32) on the clutch lever (59.9) is at the highest position, pressing down the two delrin lugs on the cartridge (61.5).

Adjustments:

Adjust the height of the clutch lever (59.9) by the screw (A) until the clearance between the pulley disc (61.2) and the feltring on the turntable (65.2) is approx. 0.5–1 mm (.02"–.04").

Recheck all other positions of the operating lever and finally seal the adjustment screw.

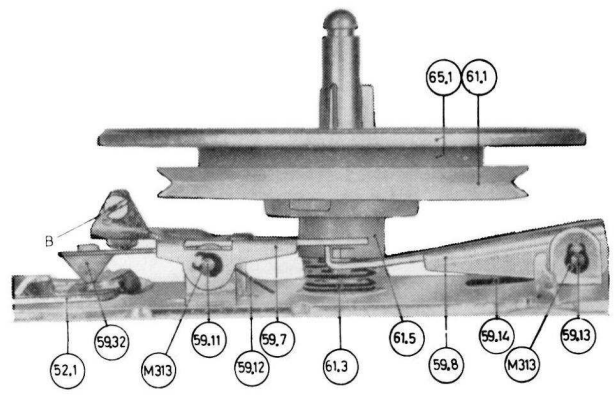

Fig. 25.

The take-up turntable

The take-up turntable (65.1) has a reduced friction with the pulley disc (61.1) in this position. The torque of the take-up turntable (65.1) should be sufficient to take up the tape in record or playback modes.

The trip bar (52.1) has moved, and the delrin button (59.32) on the upper clutch lever (59.7) is in the middle position, pressing down the spring loaded lower clutch lever (59.8). The delrin lugs on the cartridge (61.5) are released from any tension, and the pulley disc (61.1) is pressed against the turntable (65.1) by the tension of the compression spring (61.3) only.

Adjustments:

Adjust the height of the upper clutch lever (59.7) by the screw (B) until the delrin lugs on the cartridge (61.5) is in the center position between upper and lower clutch levers (59.7, 59.8).

The torque of the take-up turntable (65.1) should be 12–25 g (1/2–1 OZ) acting on an arm of 8 cm (3 1/2"). Recheck all other positions of the operating lever and finally seal the adjustment screw.

4.3.5 Neutral

The motor power is shut off, and the pulley discs (65.1, 65.2) are not running.

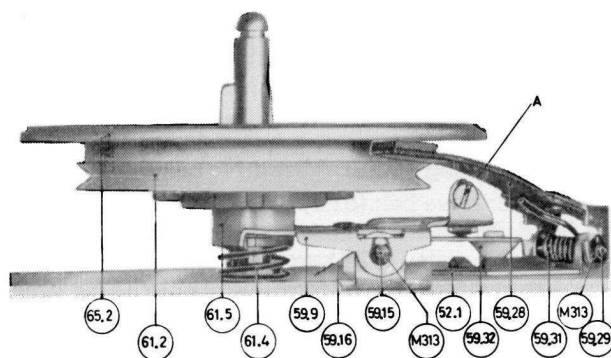

Fig. 26.

The supply turntable

The supply turntable (65.2) has maximum obtainable friction with the pulley disc (61.1) in this position. Ref. chapter 4.3.2, fast rewind.

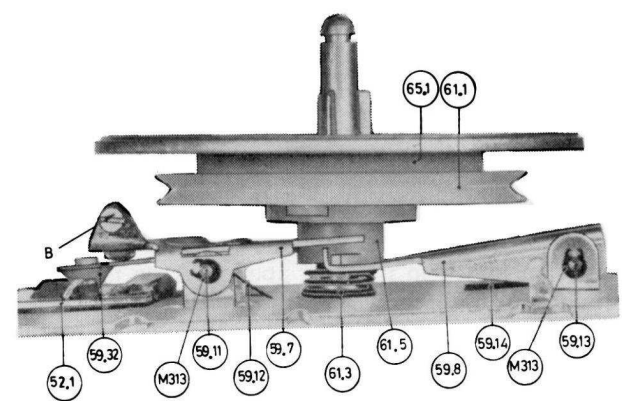

Fig. 27.

The take-up turntable

The take-up turntable (65.1) has maximum obtainable friction with the pulley disc (61.1) in this position. Ref. chapter 4.3.3, fast wind.

4.3.6 Free

The motor power is shut off and the pulley discs (65.1, 65.2) are not running.

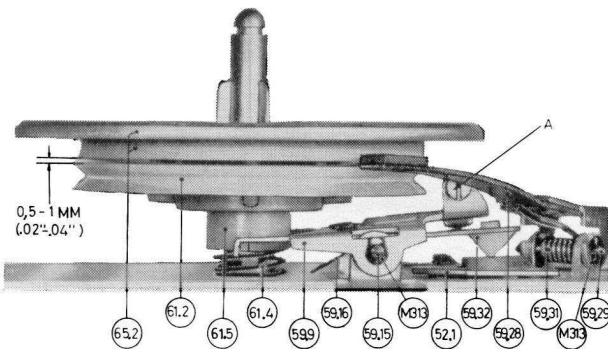

Fig. 28.

The supply turntable

The supply turntable (65.2) is completely disengaged from the pulley disc (61.2) and free-running in this position. Ref. chapter 4.3.3, fast wind.

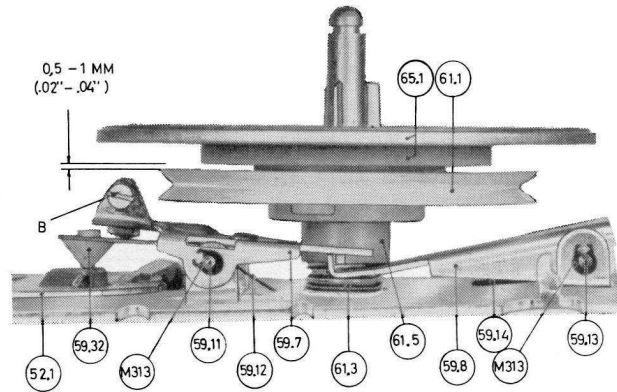

Fig. 29.

The take-up turntable

The take-up turntable (65.1) is completely disengaged from the pulley disc (61.1) and free-running in this position. Ref. chapter 4.3.2, fast rewind.

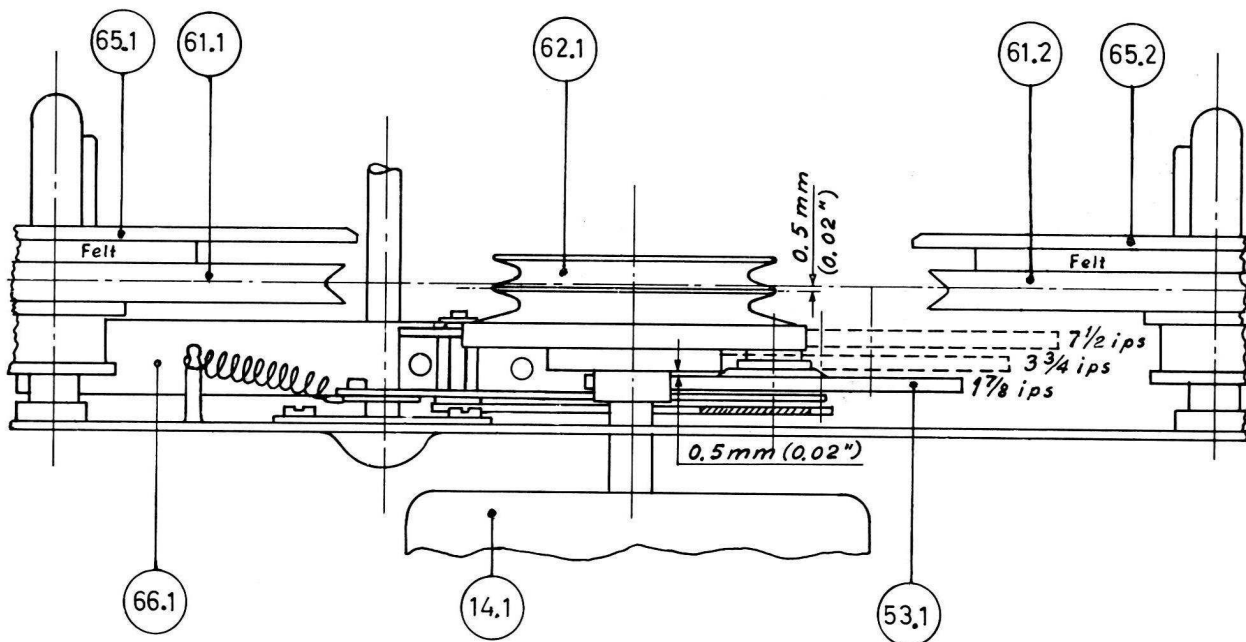

Fig. 30. The alignment of the motor pulley.

4.4 THE MOTOR PULLEY

The driving mechanism with the speed transfer wheel (53.1) engaged in the $1\frac{7}{8}$ i.p.s. track on the motor pulley (62.1) is shown in fig. 30. The motor pulley (62.1) has three tracks with different diameters for the speed transfer wheel (53.1), corresponding to the speeds $1\frac{7}{8}$, $3\frac{3}{4}$, and $7\frac{1}{2}$ i.p.s.

Adjustments:

The vertical position of the motor pulley (62.1) is adjusted with the operating lever (54.1) in neutral position. The dividing rib of the motor pulley (62.1) should be set 0.5 mm (.02") below an imaginary line drawn between the bottoms of the V-shaped grooves in the pulley discs (61.1, 61.2).

4.4.1 Threading of the rubber drive belt

The rubber drive belt (62.2) is crossthreaded as shown in fig. 5. The belt is running in the upper groove in front of the pulley (62.1), and in the lower groove at the rear of the pulley. The crossing should lie between the supply turntable (65.2) and the motor pulley (62.1).

4.5 THE SPEED TRANSFER WHEEL

The speed transfer wheel (53.1) is attached to the mounting arm (53.3) and is driven by the motor pulley (62.1). The speed transfer wheel (53.1), in turn, drives the flywheel (66.1). The spring (53.5) secures the contact of the speed transfer wheel (53.1) between the

motor pulley (62.1) and the flywheel (66.1). Ref. fig. 5 and 30.

Adjustments:

The speed selector bracket (79.11) is adjusted until the mounting arm for the speed transfer wheel (53.3) is parallel to the lower mounting plate (71.1) (unscrew the two screws M113). The spacing between the mounting arm (53.3) and the lower mounting plate (71.1) should be approx. 1 mm (.04"). Ref. fig. 33 and 5. The vertical position of the speed transfer wheel (53.1) is adjusted by adding or subtracting turbax washers (M301-2-3) between the transfer wheel holder (53.2) and the mounting arm for the transfer wheel (53.3). The spacing between the speed transfer wheel (53.1) and the higher speed track on the motor pulley (62.1) should be approx. 0.5 mm (.02") in the 1⁷/₈ i.p.s. and 3³/₄ i.p.s. position.

The vertical position of the speed transfer wheel (53.1) in the 7¹/₂ i.p.s. position should be minimum 1 mm (.04") below the upper rim of the flywheel (66.1). The flywheel (66.1) is lifted, if necessary, by adding an extra thrust washer (66.12) in the lower flywheel bearing. Ref. chapter 4.7.

The horizontal alignment of the speed transfer wheel (53.1) is adjusted by bending the transfer wheel holder (tool No. 6) until the speed transfer wheel (53.1) runs parallel to the flywheel (66.1).

4.6 THE LIFTING MECHANISM

The design of the lifting mechanism is shown in fig. 33.

The lifting arm (59.25) with the parallel arm (53.7) and the adjustment arm (53.8) is located between the upper and the lower mounting plates (71.2, 71.1). The lifting arm (59.25) is linked to the eccentric segment (59.1) while the parallel arm (53.7) is connected between the lifting arm (59.25) and the transfer wheel holder (53.2).

The lifting mechanism releases the speed transfer wheel (53.1) from contact with the motor pulley (62.1) and the flywheel (66.1) in all positions of the operating lever (54.1) except normal forward drive.

Adjustments:

Ref. fig. 32

Loosen screw A. The lifting between the speed transfer wheel (53.1) and the motor pulley (62.1) is individually adjusted for the three speeds by bending the splits X, Y and Z on the lifting arm (59.25), corresponding to the speeds 7¹/₂, 3³/₄ and 1⁷/₈ i.p.s. The lifting is occasioned by a relatively small movement of the operating lever (54.1) from normal forward drive to neutral. The lifting should be completed before the motor current is shut off by the micro-switch (33.3).

The clearance between the motor pulley (62.1) and the speed transfer wheel (53.1) at all speeds should be minimum 3 mm when the operating lever (54.1) is in neutral position.

Set the speed selector to 1⁷/₈ i.p.s. tape speed and the operating lever to neutral position. Turn the adjustment arm (53.8) until a spacing of 0,5 mm (.02") is obtained between the speed transfer wheel (53.1) and the flywheel (66.1). Turn the speed selector to

Fig. 31. The flywheel with the bearings, exploded view.

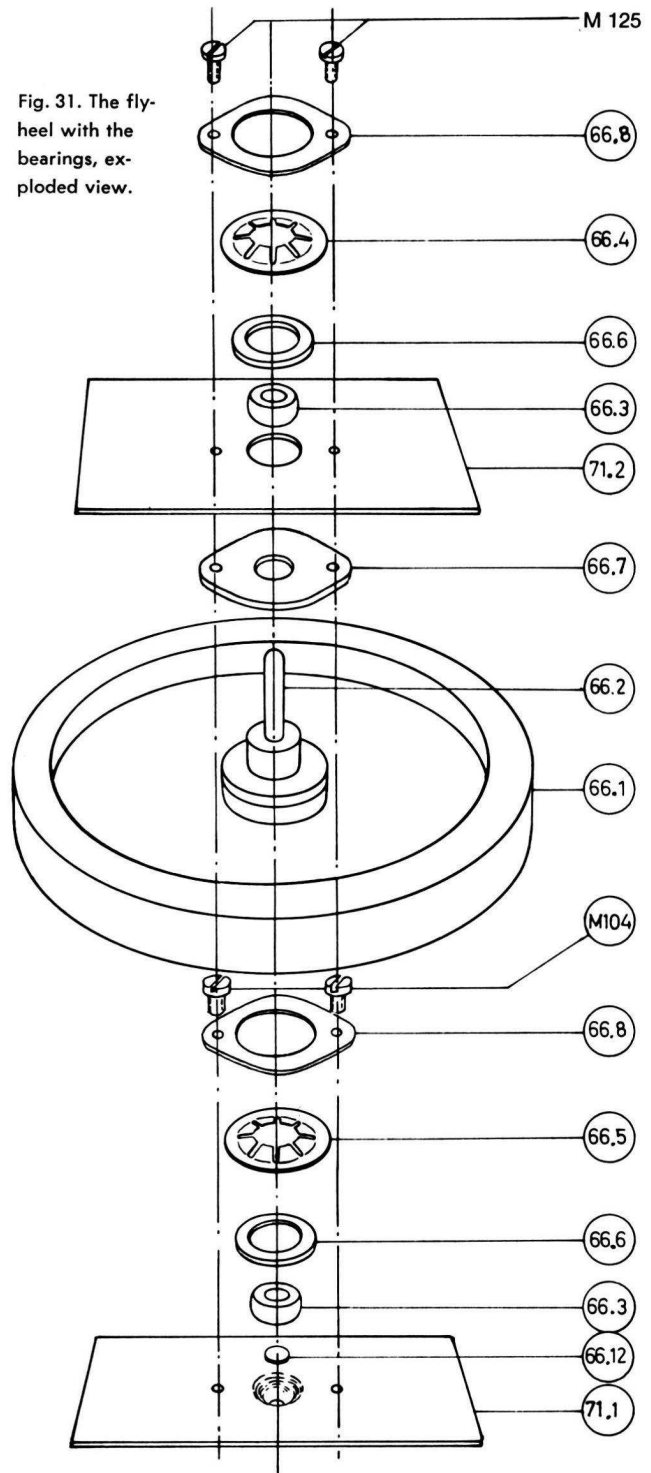

3³/₄ and 7¹/₂ i.p.s. tape speed and check that the spacing is min. 0,5 mm (.02") for both positions. Re-adjust if necessary and re-seal the adjustment screw A.

4.7 THE FLYWHEEL WITH THE CAPSTAN

The flywheel shaft acts as the capstan (62.2), and is mounted in two selflubricated and selfadjusting bearings (66.3). Ref. fig. 31.

Adjustments:

The vertical position of the capstan (66.2) is aligned with the special tool No. 5 inserted on top of the capstan as shown in fig. 32.

The two screws (M125) are loosened, and correct position of the capstan (66.2) is obtained when all three legs of tool No. 5 touches the upper mounting plate (71.2).

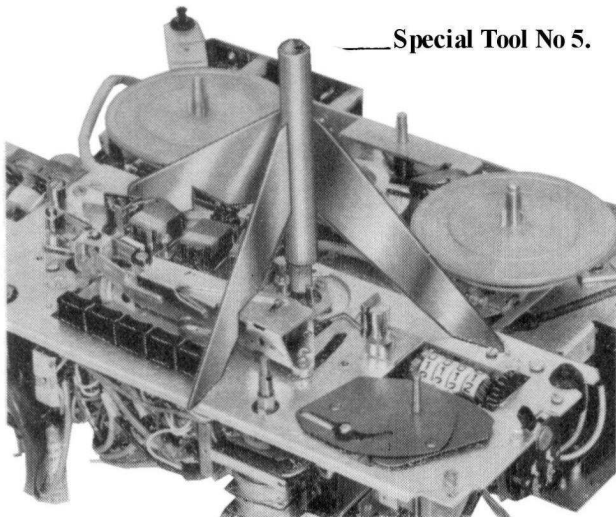

—Special Tool No 5.

Fig. 32. Alignment of the capstan with tool No. 5.

4.7.1 The brake for the flywheel

The brake spring (66.9) for the flywheel (66.1) is attached to the lifting arm for the speed transfer wheel (59.25). Ref. fig. 5.

The brake is engaged in all positions of the operating lever (54.1) except normal forward drive.

Adjustments:

The braking action is adjusted by bending the brake spring (66.9).

The motor pulley (62.1) and the flywheel (66.1) should stop simultaneously when the operating lever (54.1) is moved from normal forward drive to neutral position. Ascertain sufficient spacing between the felt pad (66.11) and the flywheel (66.1) in normal forward drive position of the operating lever (54.1).

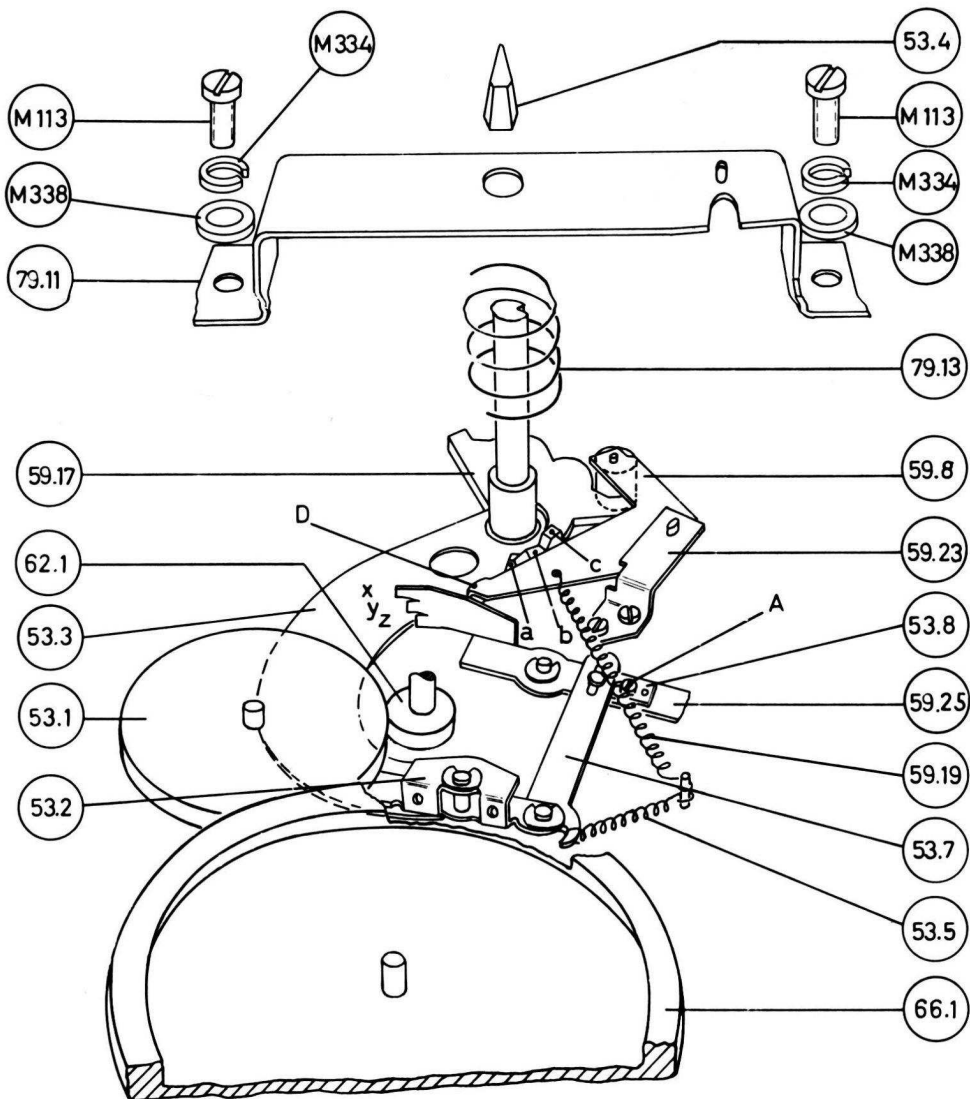

Fig. 33. The speed change mechanism.

4.8 THE SPEED CHANGE MECHANISM

The speed change mechanism is designed as shown in fig. 33.

The speed transfer wheel (53.1) is engaged with the lowest track on the motor pulley (62.1), and the mounting arm for the speed transfer wheel (53.3) is pressed against the lowest level (level a) on the cam disc (59.17) in the $1\frac{7}{8}$ i.p.s. position.

The speed transfer wheel (53.1) will be disengaged from the motor pulley (62.1), and moved out horizontally approx. 1", when the speed selector knob (53.4) is turned toward the $3\frac{3}{4}$ i.p.s. position. This horizontal movement is accomplished by the cam disc arm (59.18), which roller rests against the curvature of the cam disc (59.17). The cam disc arm (59.18) presses against the mounting arm for the speed transfer wheel (53.3) in point D.

The vertical lifting of the mounting arm for the speed transfer wheel (53.3) is accomplished by the slope of the cam disc (59.17) between the levels a and b. The slope presses the mounting arm for the speed transfer wheel (53.3) upwards from the level a ($1\frac{7}{8}$ i.p.s. position) to the level b ($3\frac{3}{4}$ i.p.s. position) during the rotation of the speed selector knob.

Adjustments:

The spacing at point D between the cam disc arm (59.18) and the mounting arm for the speed transfer wheel (53.3) should be 0.5 mm (.02") with the operating lever (54.1) in normal forward drive. The spacing is adjusted by bending the nose of the cam disc arm (59.18). Remove the motor pulley (62.1) to make this alignment.

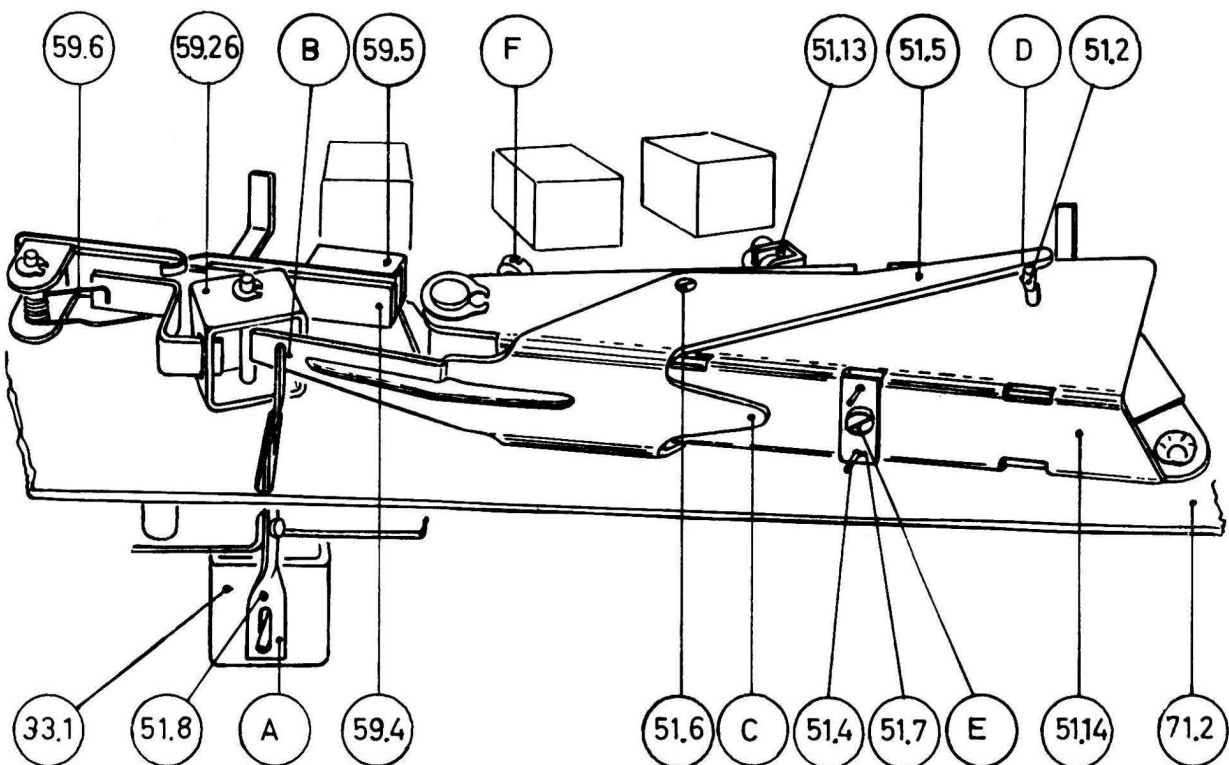

Fig. 34. The momentary start-stop mechanism.

4.9 THE MOMENTARY START-STOP FEATURE

The momentary start-stop mechanism is designed as shown in fig. 34.

The start-stop magnet (33.1) has a push-type armature which activates the start-stop lever (51.8) at point A, when the start-stop push-button is released. The start-stop lever, will in turn, press against the pressure wheel lever (51.5) in point B. The pressure wheel lever moves the pressure wheel shaft (51.2) with the pressure wheel (51.1) away from the capstan (66.2) and activates the tape brake (51.13) which prevents the tape from creeping. (Ref. chapter 4.1.4, The tape brake.)

Adjustments:

The start-stop magnet (33.1) is energized, and the armature fully attracted, when the operating lever (54.1) is in normal forward drive and the start-stop push-button released. Adjust the pressure wheel lever (51.5) by bending the flat part B to obtain a spacing of approx. 0.5 mm (.02") between the pressure wheel (51.1) and the capstan (66.2).

Start the mechanism by depressing the start-stop push-button. The start-stop magnet (33.1) is now disconnected. Adjust the pressure wheel lever (51.5) by bending the tonque C to obtain a spacing of approx. 1 mm (.04") between the pressure wheel shaft (51.2) and the pressure wheel lever (51.5) at point D.

4.10 THE PRESSURE PAD

The pressure pad (59.5) is located in front of the erase head and is introduced to secure maximum erasure, and to ensure constant friction for the tape, when the recorder is operating in normal forward drive. Ref. fig. 10 and 34.

The pressure pad arm (59.4) is activated by the pressure wheel lever (51.5) and the transfer bracket (59.26). The pressure pad (59.5) is pressing against the tape and the erase head in normal forward drive, and is completely disengaged in all other position of the operating lever (54.1).

Adjustments:

The pressure pad (59.5) should be cleaned occasionally, as the accumulation of dust and iron oxide particles might seriously affect the erasure and the tape movement.

Note: Do not soak the felt pad with any liquid.

The spring with felt for the pressure pad (59.27) is designed as a snap-on type, and can easily be pulled out by bending the two tags on the hard brass spring away from the slots in the pressure pad arm (59.4).

The tension of the pressure pad (59.5) against the erase head, in normal forward drive position, should be 75–100 g ($2\frac{5}{8}$ – $3\frac{1}{2}$ OZ). This tension is adjusted by increasing the tension of the spring for the pressure pad (59.27).

4.11 THE AUTOMATIC END STOP SWITCH

The actuating spring for the end stop switch (79.32) is located in the slot of the right tape guide (79.4). The microswitch (33.16) for the end stop is mounted under the upper mounting plate (71.2). Ref. fig. 8 and 10. The microswitch (33.16) shuts off the motor when the tape runs out or if the tape should break. The switch works independent upon the position of the operating lever (54.1).

Adjustments:

The operating point for the microswitch (33.16) is adjusted by bending the actuating spring (79.32) in point A. Ref. fig. 35. The operating point is set 0.5 mm (.02") in front of the imaginary line x–x, when the actuating spring (79.32) is moved from the rest position towards the front of the upper mounting plate (71.2).

The actuating spring shall run free inside the tape guide slot without sticking. The width of the slot is adjusted to 2 mm (.08") by bending the bracket in point B. Ref. fig. 35.

The vertical position of the actuating spring (79.32) is adjusted as shown in fig. 36. The vertical part of the spring should cover approx. 3 mm ($\frac{1}{8}$ ") of the tape. Misalignments could cause the tape to be squeezed out of the tape guide.

Ascertain sufficient clearance between the upper part of the actuating spring marked D and the front trim cover (73.1) when tape is inserted.

4.12 THE REVOLUTION COUNTER

The revolution counter (79.14) is located between the upper and the lower mounting plates (71.2, 71.1), behind the operating lever (54.1). The counter (79.14) is driven by a rubber belt (69.3) and a pulley disc (69.1) attached to the shaft of the take-up turntable (65.1). Ref. fig. 8 and 54.

Adjustments:

The pulley disc for the revolution counter (69.2) is mounted flush with the counter shaft. The pulley disc (69.1) is mounted tight up against the lock spring (79.28) for the take-up turntable. Misalignment of the vertical position of the pulleys might cause the rubber belt (69.3) to fall off.

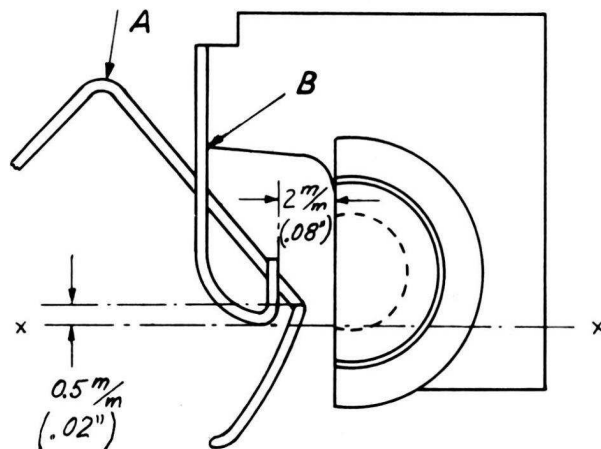

Fig. 35. Horizontal adjustment of the end stop switch.

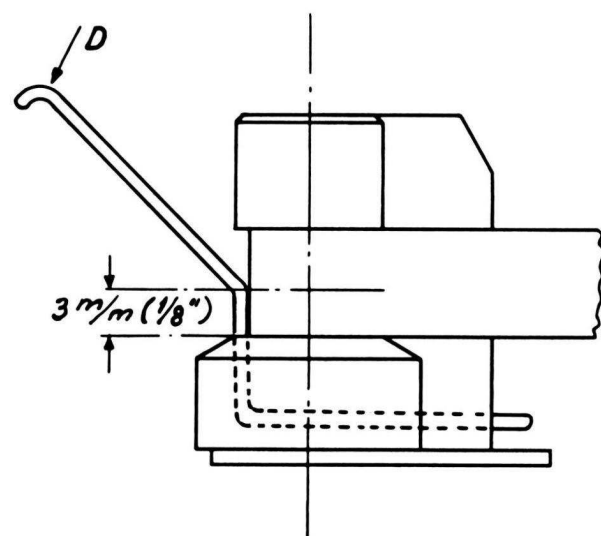

Fig. 36. Vertical adjustment of the end stop switch.

4.13 ASSEMBLING THE TOP COVER

The top cover is attached to the recorder as shown in fig. 37.

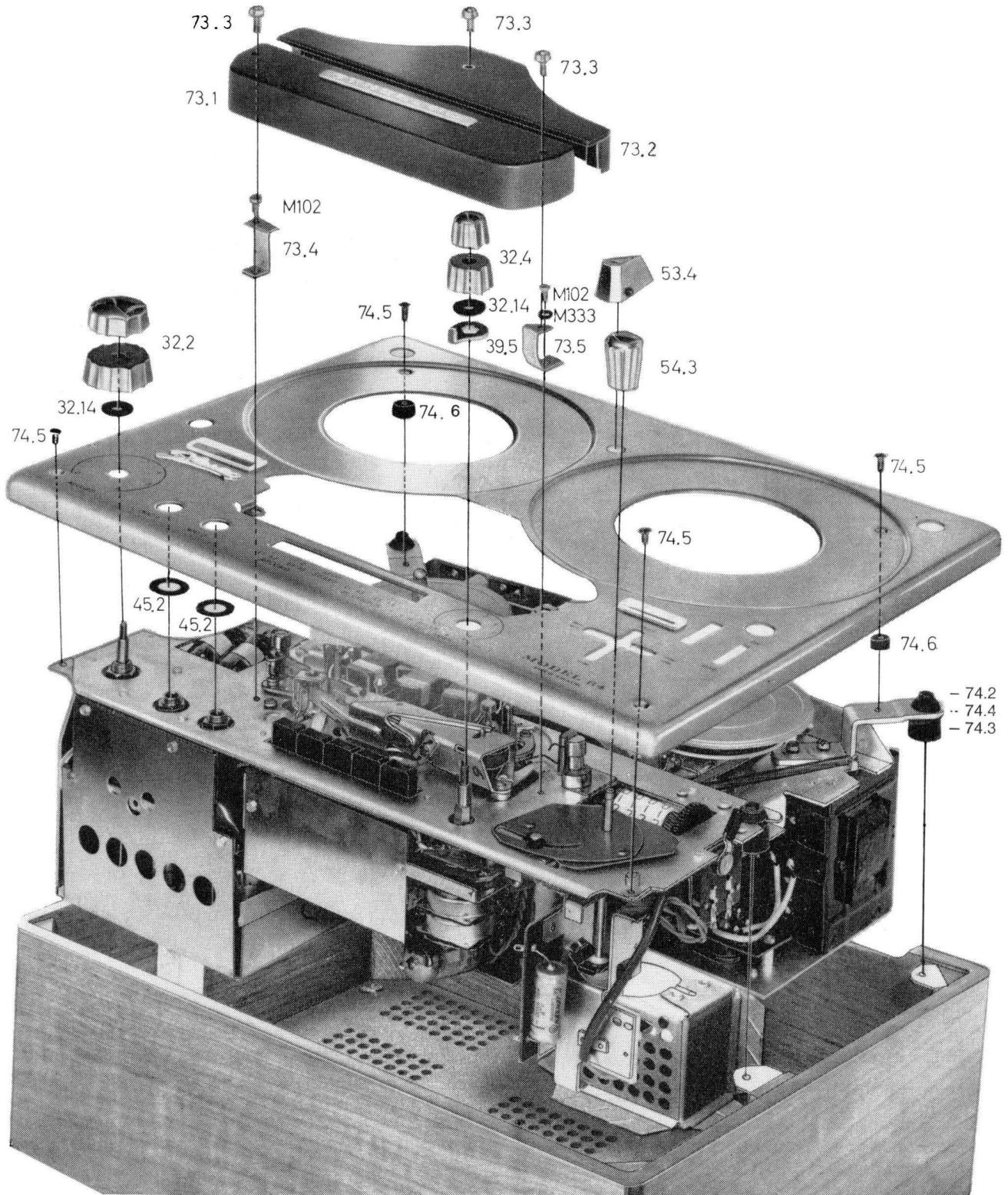

Fig. 37.

Vertical alignment of the top cover

Two thick rubber washers (74.6) have been introduced between the top cover and the mounting brackets. By tightening the two screws (74.5) slightly, the rubber

will be compressed and allow the necessary vertical adjustment of the top cover. Ref. fig. 37.

The vertical position of the top cover should be adjusted to ascertain sufficient spacing between the plastic tape reels and the top cover in all modes of operation.

5.0 The electronic circuits detailed description and adjustment instructions

5.1 THE MAIN ELECTRONIC UNITS, BLOCK DIAGRAM

The simplified block diagram for the Tandberg tape recorder models 64 and 62 is shown below. Ref. fig. 38.

The tape recorders are equipped with the following separate units:

- 2 Record pre-amplifiers
- 2 Record amplifiers
- 2 Record level indicator circuits
- 1 Oscillator
- 2 Playback pre-amplifiers
- 2 Cathode followers

The momentary start-stop circuit
The power supply
The switching system.

The different units can be interconnected in various combinations by the switching system, creating a very flexible tape recorder.

The amplifiers are equalized to conform with the N.A.B. standards.

The amplifiers are identical for the two channels, and only the amplifiers for the upper track are therefore explained in the following discussions.

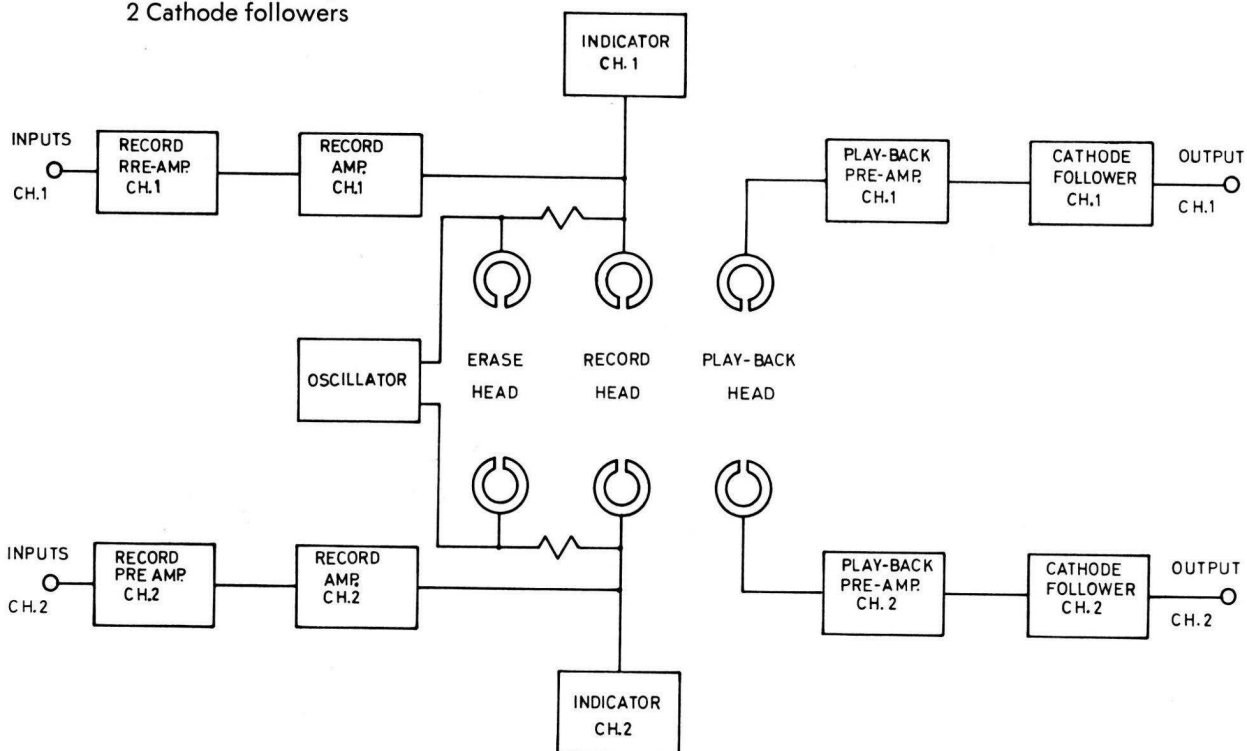

Fig. 38. Block diagram, models 64 and 62.

5.1.1 The record pre-amplifier

The schematic for the record pre-amplifier is shown below. Ref. fig. 39.

The record pre-amplifier is a two stage amplifier using the double triode ECC83 (12AX7). The record gain control R109 controls the input to the second amplifier stage.

The record pre-amplifier has the following three inputs: high level, low level, and microphone input.

The high level input signal is reduced $1/27$ by R1 and R3. The low level input signal is reduced $1/2,7$ by R2 and R3. The microphone input is connected directly to the input of the first tube.

Programme mixing is possible through the high and low level inputs. The microphone jack disconnects the high and the low level inputs from the grid of the first stage when the microphone plug is inserted.

The output signal from the record pre-amplifier passes the record level adjustment potentiometer R115 and is fed to the input of the record amplifiers.

The output from the record pre-amplifier (point 5) can be connected to the cathode follower input by the switching system.

The frequency response of the record pre-amplifier is straight. No equalization has been introduced. The capacitors C1, C2, and C105 will give a slight boost of the high frequencies to compensate for high frequency losses caused by the wiring of the amplifier.

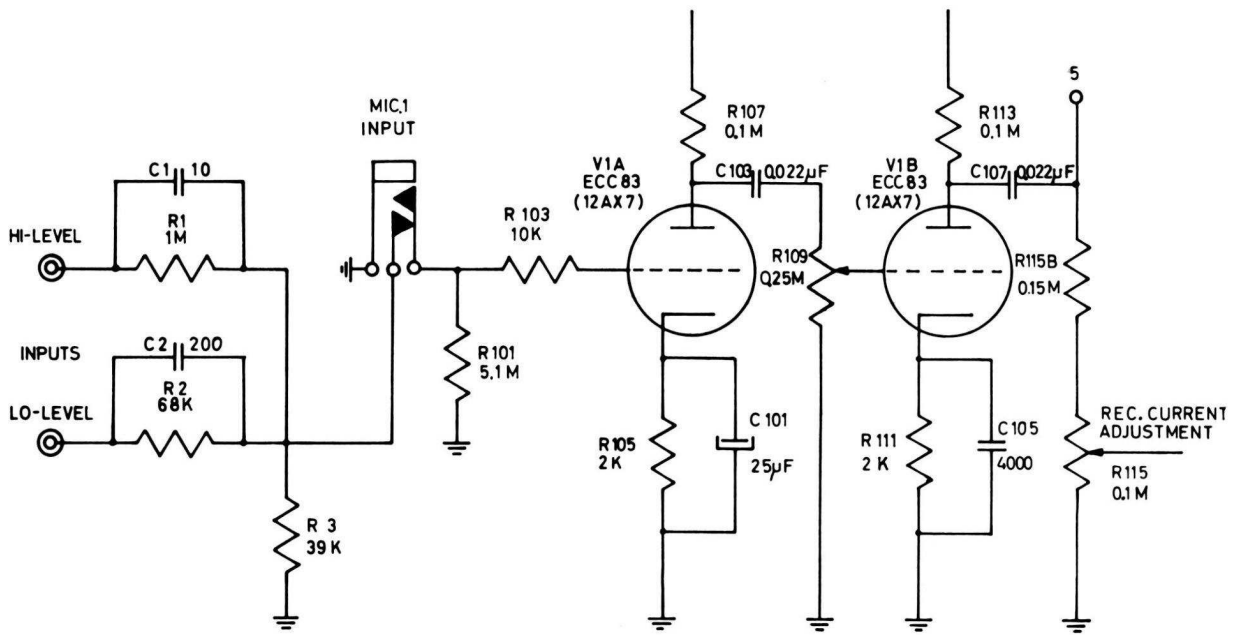

Fig. 39. The record pre-amplifier, schematic.

5.1.2 The FM-multiplex filter

The two low level inputs have been replaced by 19 kc/s FM-multiplex filters on tape recorders sold in certain territories.

The 19 kc/s pilot signal that might appear on the output terminals of the FM-multiplex tuner is rejected by the series resonant circuit C30, L4. Ref. fig. 40.

Note: The FM-multiplex filters have been changed from serial No. 636301.

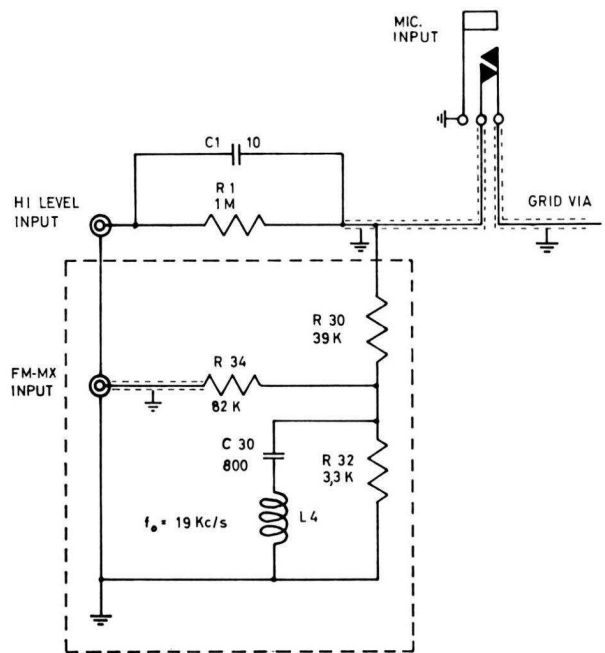

Fig. 40. The FM-multiplex filter, schematic.

PART	SERIAL NUMBERS BELOW 636301	SERIAL NUMBERS ABOVE 636301
R32	1 kohm, ½ W, 10 %	3,3 kohm, ½ W, 10 %
R33	1 kohm, ½ W, 10 %	3,3 kohm, ½ W, 10 %
R34	27 kohm, ½ W, 10 %	82 kohm, ½ W, 10 %
R35	27 kohm, ½ W, 10 %	82 kohm, ½ W, 10 %
C30	2200 pF, 125 V, 2½ %	800 pF, 125 V, 2½ %
C31	2200 pF, 125 V, 2½ %	800 pF, 125 V, 2½ %
L4	L4-6C	L4-1-6C
L5	L5-6C	L5-1-6C

5.1.3 The record Amplifier

The schematic for the record amplifier is shown below. Ref. fig. 41.

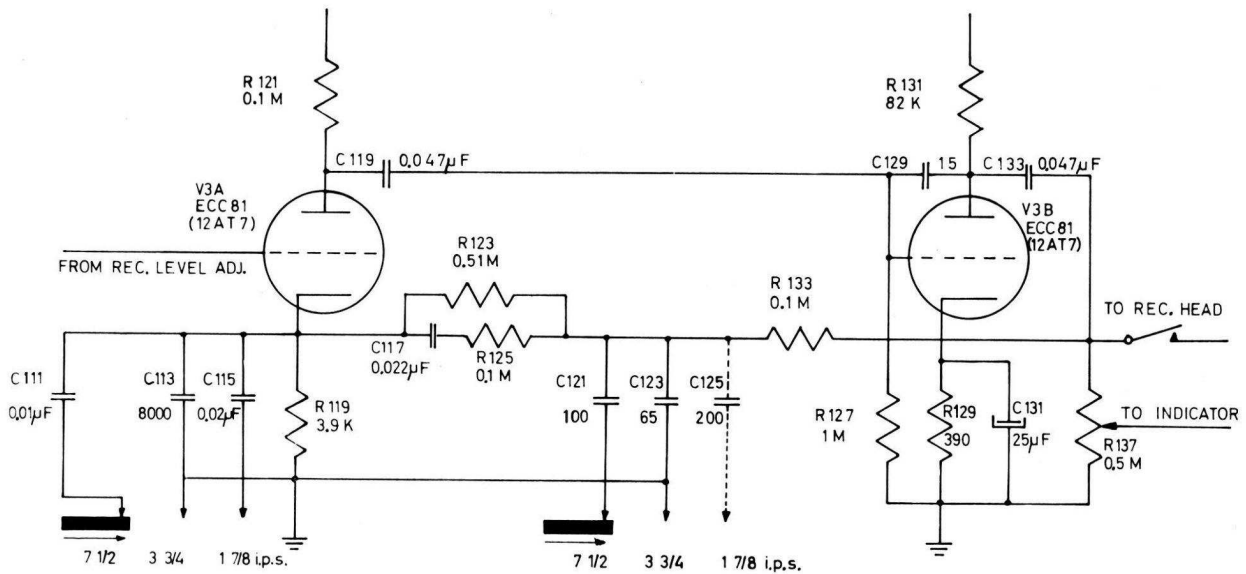

Fig. 41. The record amplifier, schematic.

The record amplifier is a two stage amplifier using the double triode ECC81 (12AT7). The input signal is fed directly to the grid of V3A from the record level adjustment potentiometer R115.

The entire record equalization is obtained by the negative feedback circuits connected from the anode of V3B to the cathode of V3A. Mainly the high frequencies are compensated in the record amplifier. Ref. fig. 42.

The speed compensation is obtained by the combination of C111 - C113 - C115 and C121 - C123 - C125 in the frequency dependent feedback circuit. The equalization switch is linked to the speed selector switch, and correct combination of the capacitors is automatically obtained when the tape speed is changed.

The frequency compensation of approx. + 1.5 dB at 30 c/s is obtained by the capacitor C117.

The capacitor C129 acts as a high frequency stabilizer for the amplifier.

The record head is connected across the potentiometer R137. The indicator circuit is connected to the center-tap of the potentiometer R137.

Note: The tube ECC83 (12AX7) has been replaced by ECC81 (12AT7) in the record amplifiers from serial No. 661001. For further information ref. chapter 5.9. Introduction of ECC81 (V3 and V4).

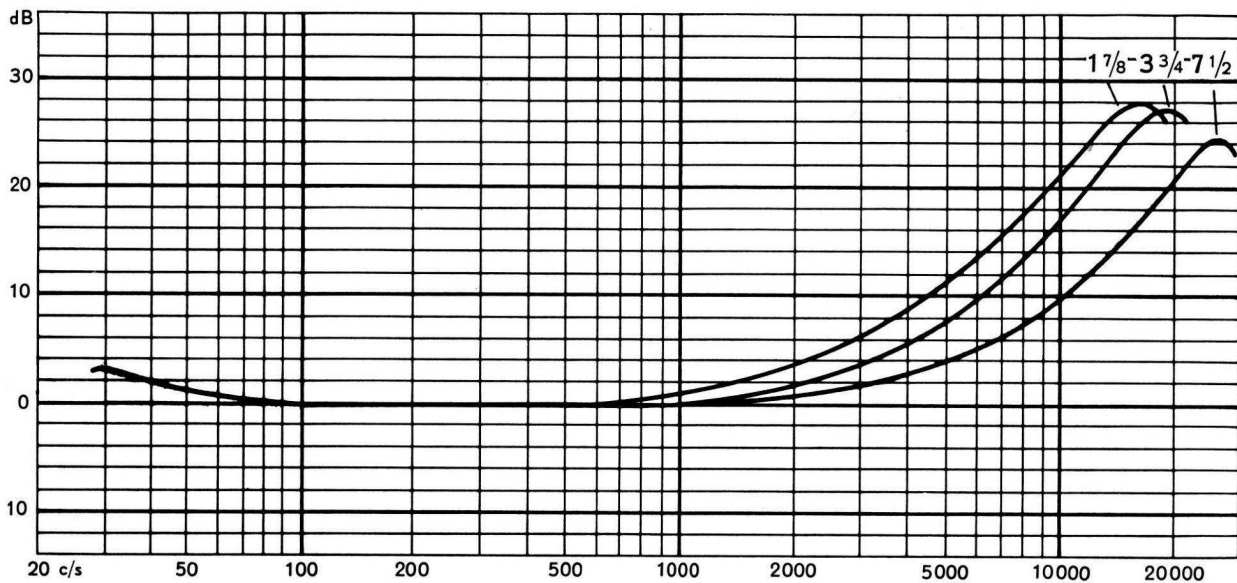

Fig. 42. The response curves for the record amplifier.

5.1.4 The playback pre-amplifier

The schematic for the playback pre-amplifier is shown below. Ref. fig. 43.

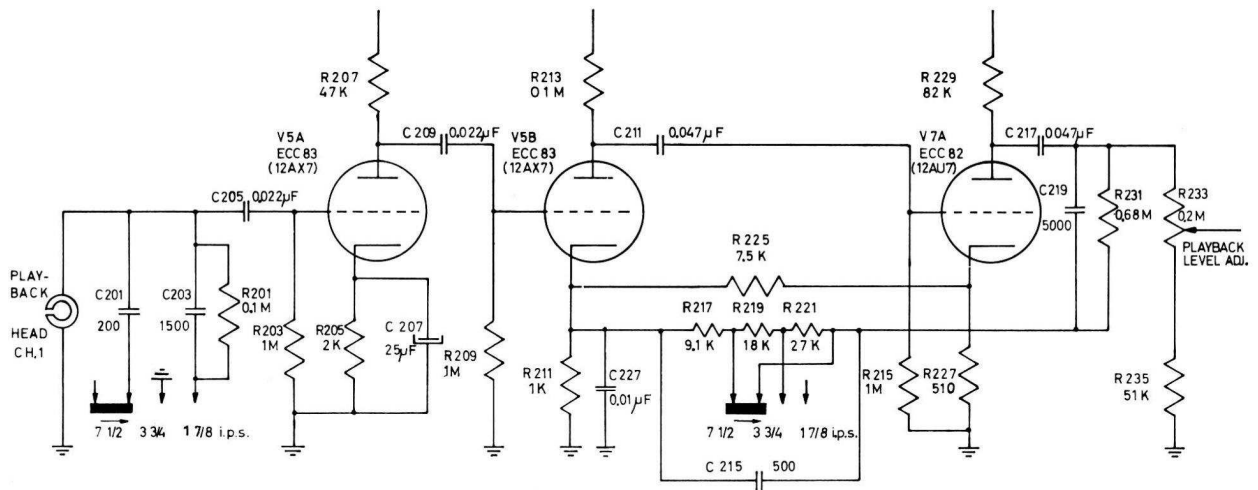

Fig. 43. The playback pre-amplifier, schematic.

The playback pre-amplifier is a three stage amplifier using one double triode ECC83 (12AX7) and one section of the double triode ECC82 (12AU7). The entire playback equalization is obtained by the combination of the following circuits in the playback pre-amplifier.

1. The positive feedback from the cathode of V7A to the cathode of V5B (R225) increases the amplification of the low frequencies to conform with the N.A.B. standards.
2. The variable negative feedback circuit from the anode of V7A to the cathode of V5B (R217, R219, R221, R231 - C219, C227) will give the correct high-frequency response at the different tape speeds.
3. The playback head, together with the capacitors

C201, C203 and the resistor R203 forms a variable resonant circuit and compensates for playback losses at high frequencies.

The equalization switch is linked to the speed selector switch, and correct equalization for the different speeds is automatically obtained when the tape speed is changed. Ref. fig. 44.

The output voltage from the cathode follower is adjusted to 1.5 V by R233 with the playback volume controls set to maximum, when a pre-recorded tape (400 c/s, test tape No. 4) is played back.

The muting switch is shortcircuiting the output from the playback pre-amplifier to ground in all positions of the operating lever, except normal forward drive. The switch is introduced to prevent noise from the playback amplifiers when the tape recorder is used as a pre-amplifier.

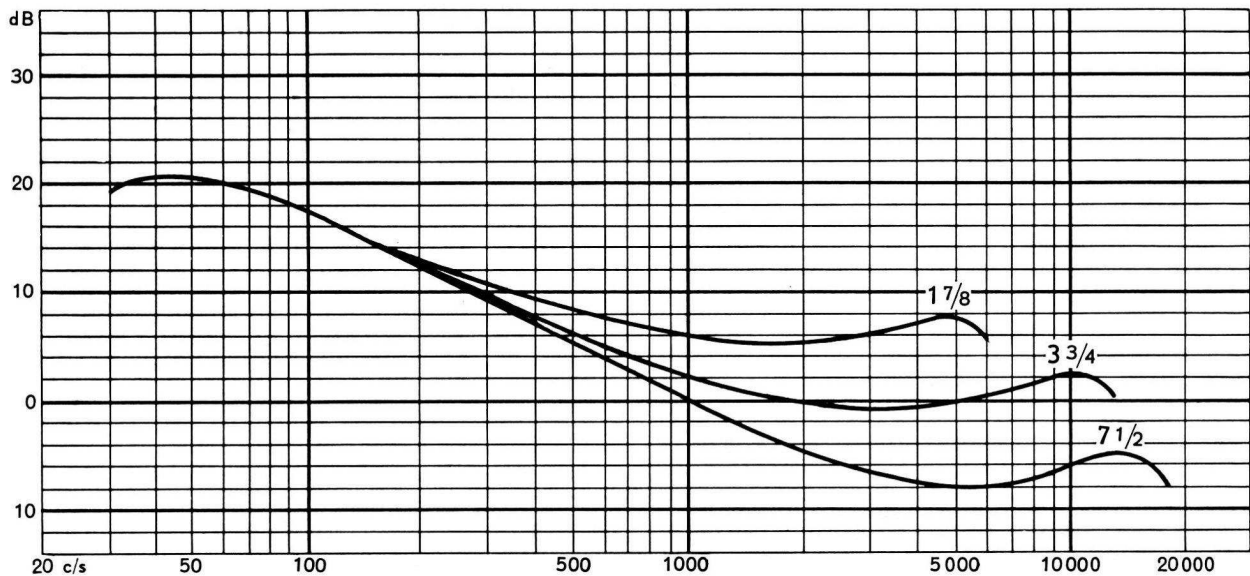

Fig. 44. The response curves for the playback pre-amplifier.

5.1.5 The cathode follower

Ref. fig. 45.

One section of the double triode ECC82 (12AU7) is used as the cathode follower.

The input voltage is adjusted by the playback volume control R18. The capacitor C225 blocks DC voltage from the output terminals.

The minimum load resistance is 2 kohm to keep the total distortion below 2%.

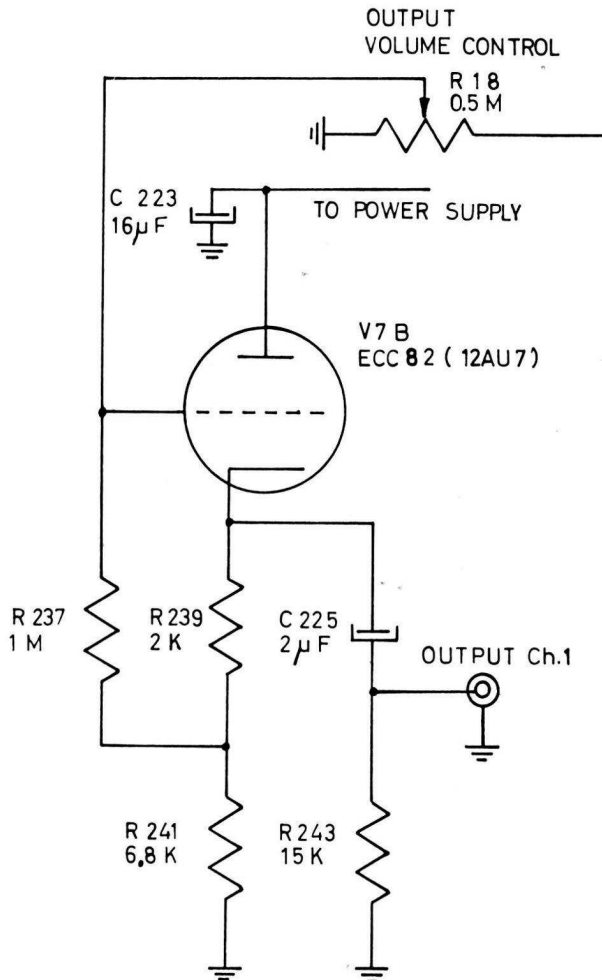

Fig. 45. The cathode follower, schematic.

5.1.6 The record level indicator circuit

Ref. fig. 46.

The EAM86 is a combined rectifier, triode and indicator tube.

The input of the indicator circuit is connected to the center-tap of R137 in the record amplifier.

The signal is first rectified in the diode section of the EAM86. The DC signal is filtered by the damping circuit R407, C405 and connected to the grid of the amplifier section. The amplifier anode is connected directly to the indicator anode. The indicator target is connected to + 230 V from the power supply.

The record level indicator is adjusted by R137 to close at a recording level corresponding to 3% distortion on a recorded tape (400 c/s) when played back.

The indicator maintains the sensitivity over the entire audio range from 30 c/s to 20 000 c/s.

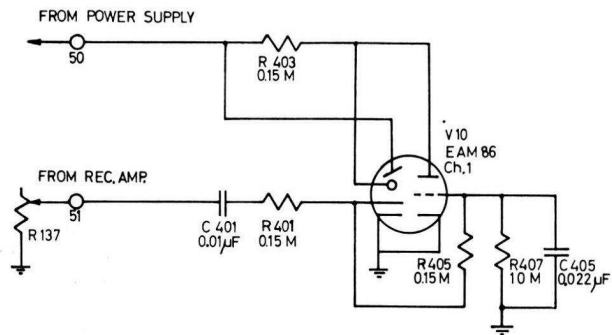

Fig. 46. The electronic beam indicator circuit, schematic.

5.1.7 The oscillator, bias, and erase circuits

The schematic for the oscillator with the bias and erase circuits is shown below. Ref. fig. 47.

The oscillator is of the push-pull type, using the double triode ECC82 (12AU7).

The anode voltage is supplied to the center-tap of the transformer L1.

The high frequency output voltage across the secondary winding of the transformer L1 is kept constant even when recordings are made on either one or both channels. The variation of the output voltage caused by variation of the oscillator load is compensated by supplying the oscillator plates with a slightly higher voltage when recordings are made on both channels. This is accomplished by the resistors R7, R10 and the switches marked I (ch. 1) and II (ch. 2).

The resistor R7 is shortcircuited when only push-button I is depressed.

The resistor R10 is disconnected when only push-button II is depressed.

The resistors R7 and R9 are both shortcircuited when the push-buttons I and II are depressed.

The oscillator frequency is set to 78 kc/s by adjusting the core of the transformer L1.

The variation of the oscillator frequency, caused by the load variation of the oscillator, between monaural or stereo recording, is compensated by the capacitor C307. C307 is connected across the secondary winding of the transformer L1 when the record push-buttons I and II are depressed.

The lower erase head is connected directly to the oscillator output. The upper erase head is connected in series with the capacitor C302 to the oscillator output to prevent hum from stray fields.

C17 will be discharged slowly and cause damped oscillations of the oscillator to secure negligible residual magnetism in the erase and record heads when the push-button III is released while one or both of the push-buttons I and II are depressed.

The bias current from the oscillator to the record heads is adjusted by the potentiometers R302 and R301.

The series resonant circuits C305 - L2 and C306 - L3 rejects the bias frequency from the output circuits of the record amplifiers. The magnetic fields produced by the two erase head halves are 180° out of phase to prevent unwanted erasure of the track in between the two tracks being recorded.

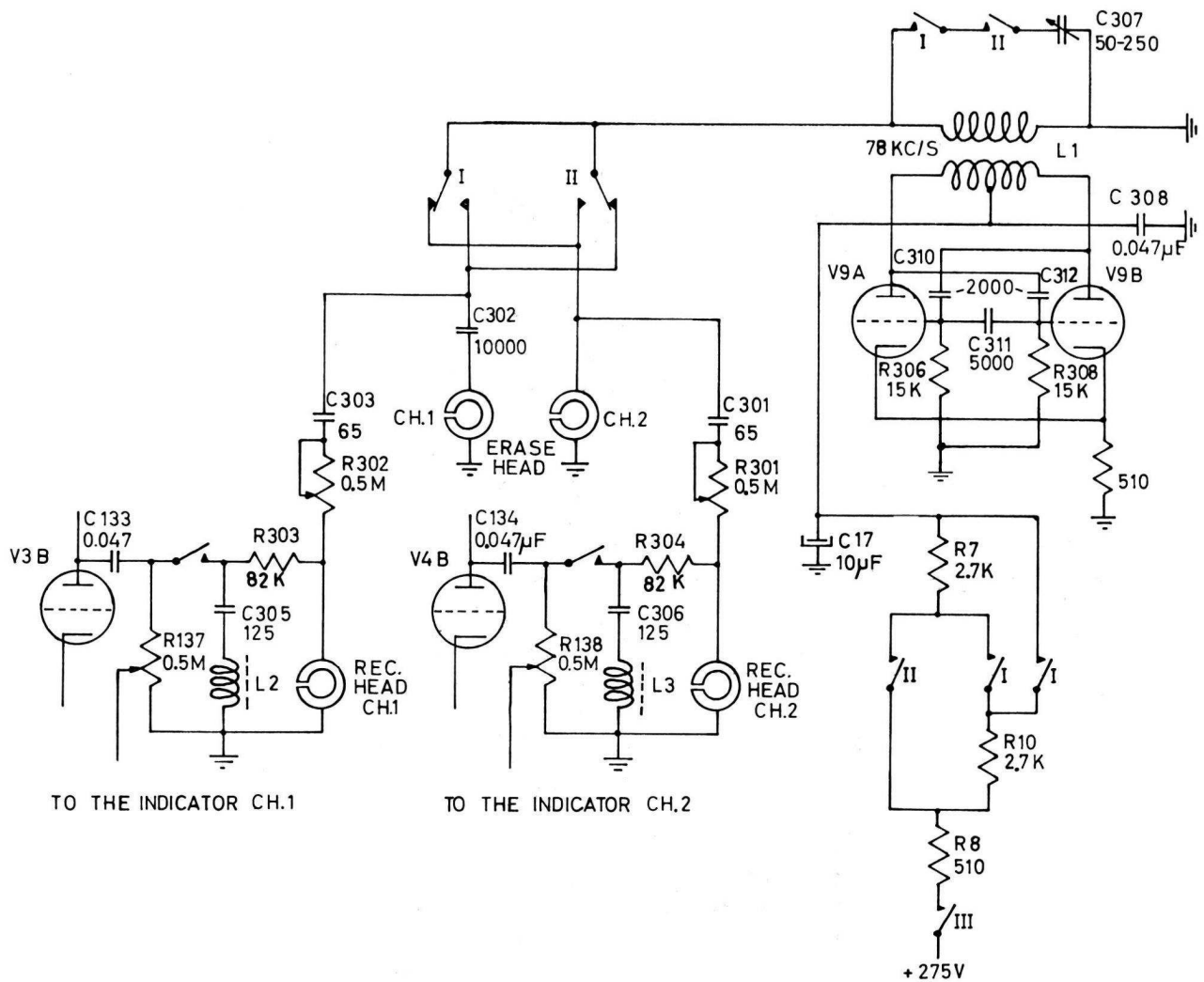

Fig. 47. The oscillator, bias and erase circuit, schematic.

5.1.8 The momentary start-stop circuit

The schematic for the momentary start-stop circuit is shown below. Ref. fig. 48.

The mechanical operation of the momentary start-stop feature is described in chapter 4.9.

The operating lever is set in position normal forward drive.

1. The start-stop push-button is released:

The start-stop magnet (33.1) retains attracted by the bleeder current through the resistor R13. The tape is not moving due to the pressure wheel (51.1) being disengaged from the capstan (66.2).

2. The start-stop push-button is depressed:

The start-stop magnet (33.1) is disconnected by the contact III₁₃ which has moved to III₁₄. The tape is moving due to the pressure wheel (51.1) being engaged with the capstan (66.2). The capacitor C7 is charged to 350 V DC over R13.

3. Releasing the start-stop push-button:

The contact III₁₃ is moved back to position III₁₂. The charged energy in C7 attracts the start-stop magnet (33.1). The pressure wheel (51.1) disengages from the capstan (66.2) and stops the tape. The start-stop magnet (33.1) retains attracted by the bleeder current through the resistor R13.

The tape will start moving, even with the start-stop push-button released (stop position), if the operating lever (54.1) is engaged in normal forward drive position before the main switch is turned on. The capacitor C7 has not yet been charged to 350 V and the bleeder current through R13 is not sufficient to attract the start-stop magnet (33.1). The start-stop magnet (33.1) will again work properly when the start-stop push-button is operated once.

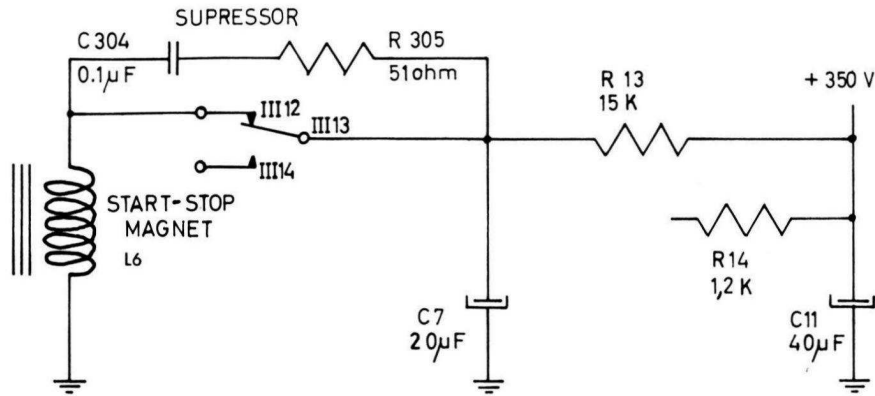

Fig. 48. The momentary start-stop circuit, schematic. The start-stop push-button released (stop position).

5.1.9 The power supply

The schematic for the power supply is shown below, ref. fig. 49.

The mains transformer 11.1-273-1 is equipped with a mains selector for 110 - 125 - 145 - 200 - 220 - 245 V, and can be used for 50 - 60 c/s.

Note: The mains voltage indicator plate at the bottom of the tape recorder should always show the voltage for which the transformer is connected.

The transformer 11.1-273-1 is furnished with a melting

fuse (Rose metal) in the primary winding. All secondary windings are fused with slow-blow fuses.

The 245 volts secondary winding is connected to the bridge rectifier B250 - C75 and furnishes all high voltages to the amplifiers, indicators, oscillator, and to the motor.

The 25 volts secondary winding is connected to the rectifier B30 - C1000 and furnishes the DC filament voltage to all amplifier and cathode follower tubes. These tubes are DC heated to prevent hum.

The 6,3 volts secondary winding furnishes the AC filament voltage to the pilot lamp and the oscillator and indicator tubes.

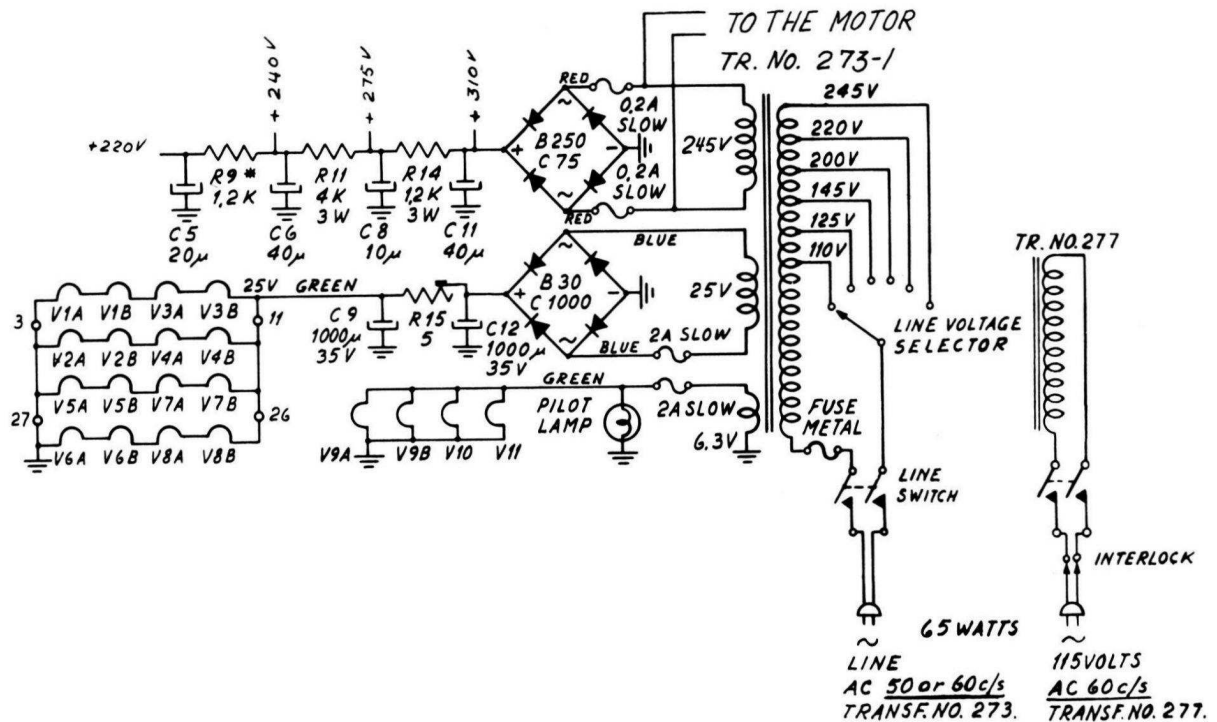

Fig. 49. The power supply, schematic.

Note: The transformer 11.1-277 and the interlock system inserted in the main cord is furnished on tape recorders sold in certain territories to conform with the UL approval.

Note: The power transformer 11.2-273 has been replaced by 11.2-273-1 from ser. No. 657001. The 260 volt secondary winding is reduced 7 % and the following changes must be introduced in the circuit.

COMPONENT	TRANSFORMER 11.1-273	TRANSFORMER 11.1-273-1
R7	3.9 K ohm	2.7 K ohm ½ W, 10 %
R8	3.9 K ohm	510 ohm ½ W, 10 %
R10	3.9 K ohm	2.7 K ohm ½ W, 10 %

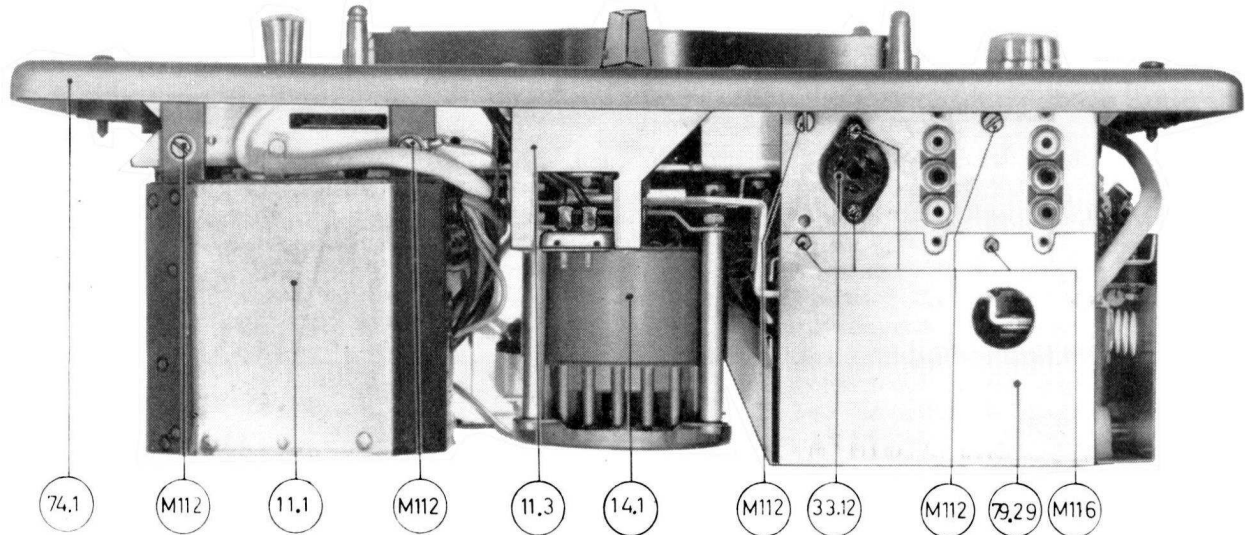

Fig. 50. Rear view of tape recorder equipped with Papst motor and transformer 11.1-277-6C.

5.2 THE SWITCHING SYSTEM, BLOCK DIAGRAM

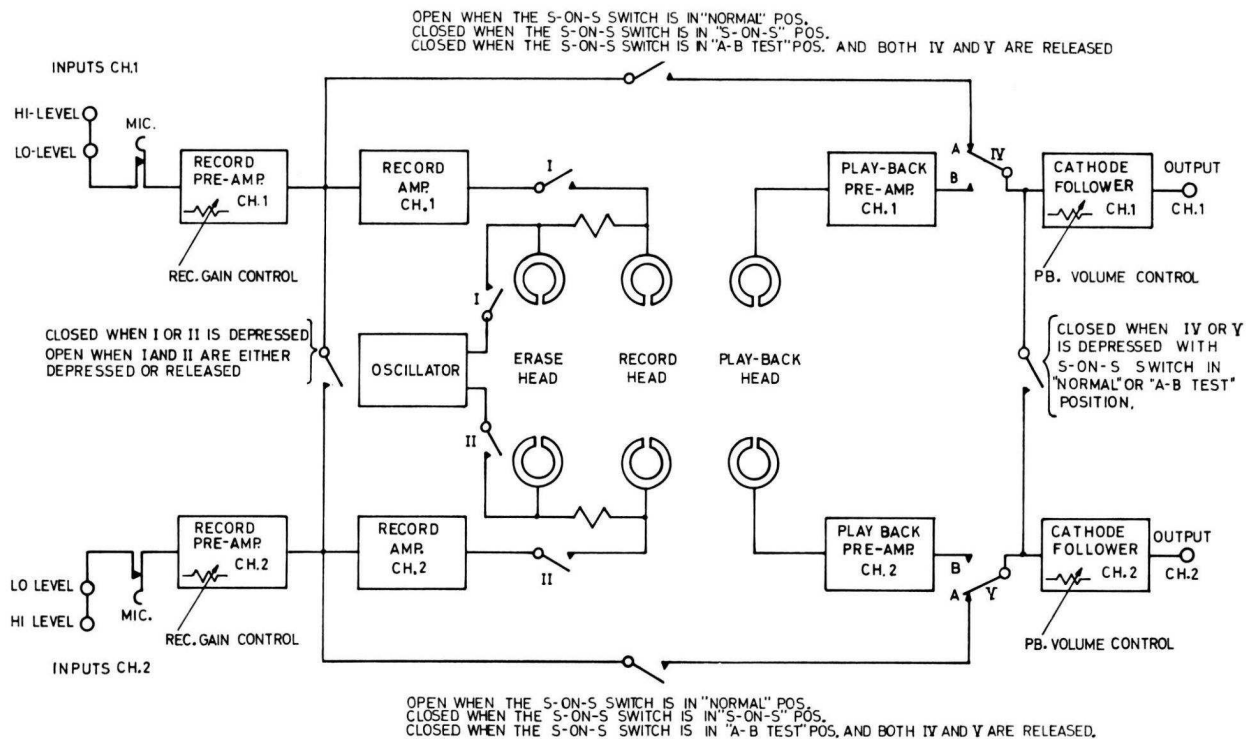

Fig. 51. The switching system, block diagram. All push-buttons released.

5.2.1 The push-button switch

Roman numerals are used as reference to the different push-buttons in the following description. Ref. fig. 52.

- I Record push-button channel 1
- II Record push-button channel 2
- III Start-stop push-button
- IV Playback push-button channel 1
- V Playback push-button channel 2

5.2.2 The S-on-S switch

The S-on-S switch has the following three positions. Ref. fig. 52.

- 1. A-B test
- 2. Normal
- 3. S-on-S.

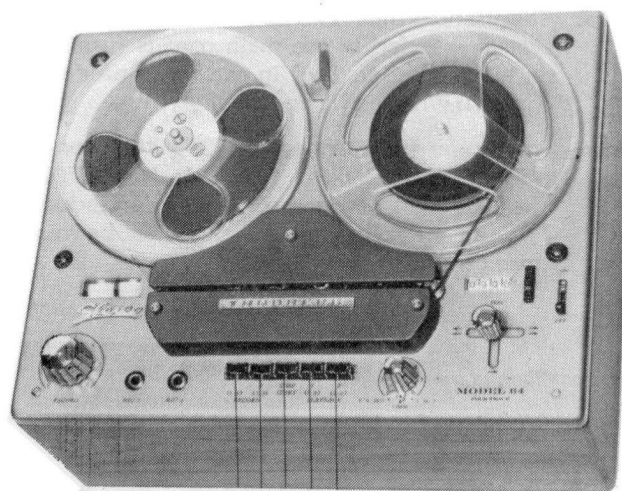

Fig. 52. The push-buttons.

5.2.3 Monaural recording on channel 1 or 2

Ref. block diagram fig. 51.

We presume that we are recording on ch. 1 (upper track). The input signal is fed to the microphone jack ch. 1 and the push-button I is depressed. The S-on-S switch is in position A-B test, and the push-button IV is released.

The signal passes through the record pre-amplifier ch. 1 and the record amplifier ch. 1 to the record head. The erase head ch. 1 is activated.

The input of the cathode follower ch. 1 is connected to the output from the record pre-amplifier ch. 1 through the push-button IV. We are monitoring the input signal *b e f o r e* it is recorded on the tape (A-test).

The output from the playback pre-amplifier ch. 1 is connected to the input of the cathode follower ch. 1 by depressing the push-button IV. We are monitoring the signal from the tape *a f t e r* it is recorded on the tape (B-test).

The signal from the record pre-amplifier ch. 1 is also connected to the input of the cathode follower ch. 2 through the push-button V. We are monitoring the input signal from the output of the record pre-amplifier ch. 1 through both cathode followers in A-test when the push-button IV and V are released.

The input signal can be monitored through the cathode follower ch. 1 in B-test (push-button IV depressed) and through the cathode follower ch. 2 in A-test (push-button V released). The delay between the two reproduced signals is caused by the mechanical distance between the record and playback heads. This delay is used to introduce the echo effects described in chapter 5.2.11.

5.2.4 Mixing during monaural recording

Ref. block diagram fig. 51.

We presume that the mixed programme (programme 1 and 2) is to be recorded on ch. 1 (upper track). Programme 1 is connected to the high level input ch. 1 and programme 2 is connected to the high level input ch. 2.

The outputs from the two record pre-amplifiers are connected together when the push-button I (or II) is depressed. The two programmes are mixed and fed to the record amplifier and the record head ch. 1. The record levels are controlled separately for the two programmes by the record gain controls.

Four programmes might be mixed together on one channel during monaural recording by feeding different programmes into both high level and low level (FM-MX) inputs on the record pre-amplifiers ch. 1 and ch. 2. The record levels of the two programmes connected to the same pre-amplifier cannot be adjusted separately.

Note: The high level and the low level (FM-MX) inputs are disconnected when the microphone plug is inserted.

5.2.5 Stereo recording

Ref. block diagram fig. 51.

The two signals pass through each record pre-amplifier and record amplifier to the record heads.

The connection between the two record pre-amplifier outputs is disconnected when the push-buttons I and II are depressed.

The signals from the outputs of the record pre-amplifiers are connected to the inputs of the cathode followers through the push-button IV and V. We are monitoring the input signals from the output of each record pre-amplifier (A-test).

The inputs of the cathode followers will be connected to the outputs of the playback pre-amplifiers by depressing the push-buttons IV and V. We are monitoring the recorded signals from the tape (B-test).

5.2.6 Mixing during stereo recording

Ref. block diagram fig. 51.

Two programmes might be mixed together on each channel during stereo recording by feeding programme 1 to the high level input and programme 2 to the low level (FM-MX) input simultaneously. The record level of the two programmes connected to the same pre-amplifier input cannot be adjusted separately.

Note: The high level and the low level (FM-MX) inputs are disconnected when the microphone plug is inserted.

5.2.7 Monaural playback channel 1 or 2

Ref. block diagram fig. 51.

We presume that the recorded programme is played back from channel 1.

The output from the playback pre-amplifier ch. 1 is connected to the input of the cathode follower ch. 1 through the push-button IV. The inputs of the two cathode followers are connected together. The programme will be reproduced through both outputs.

5.2.8 Stereo playback

Ref. block diagram fig. 51.

The playback push-buttons IV and V are depressed. The signals will pass each playback pre-amplifier and be fed to the inputs of the two cathode followers. The interconnection between the inputs of the cathode followers is disconnected.

5.2.9 Add a track

Ref. block diagram fig. 51.

The «add a track» recording is a technique of playing back a pre-recorded programme from one channel, and record another programme on the other channel at the same time. Both programmes will be heard simultaneously when the tape is played back in stereo. We presume that the pre-recorded programme is recorded on channel 1. The push-button IV is depressed and the programme is reproduced through the cathode follower ch. 1.

The recording is made on ch. 2 and the push-button II is depressed. The sound on sound switch is set to pos. S-on-S. The signal passes through the record pre-amplifier ch. 2 and the record amplifier to the record head ch. 2. The signal is fed from the output of the pre-amplifier ch. 2 to the cathode follower ch. 2 through the push-button V (A-test).

The input of the cathode follower ch. 2 is connected to the output of the playback pre-amplifier ch. 2 by depressing the push-button V. The signal is monitored from the tape (B-test) and reproduced through the cathode follower ch. 2.

A delay of 150 ms. for the 7½ i.p.s. tape speed is introduced between the two programmes, caused by the mechanical distance between the record and playback heads.

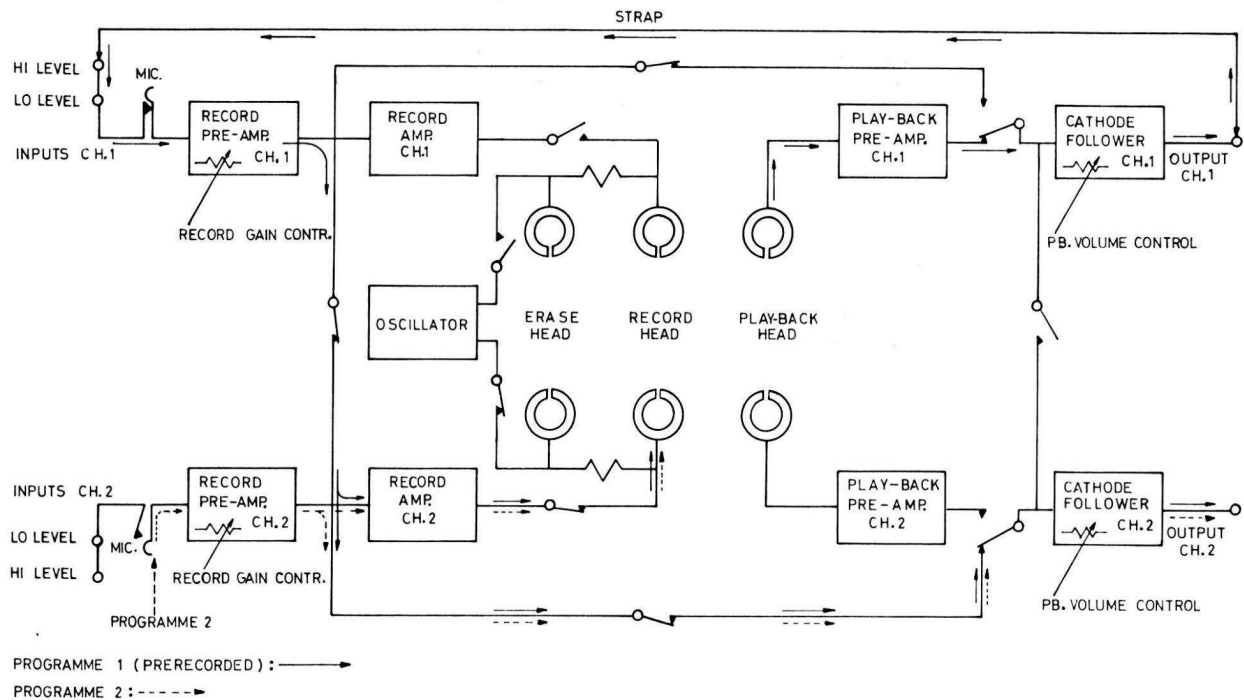

Fig. 53. Sound on sound recording, block diagram. Push-buttons II, III and IV depressed. Sound on sound switch in S-on-S pos.

5.2.10 Sound-on-sound

Ref. block diagram fig. 53.

The sound on sound recording is a technique of adding sound on to an already existing recording. We presume that the existing programme is recorded on channel 1. This programme is played back and transferred to channel 2 where it is recorded and superimposed by the additional sound. The result is a recording of two programmes combined on one track. The programme is played back as a monaural recording. Programmes may be built up in sequence by adding new instruments or voices as required.

Preferred instructions for sound on sound recording

The output from ch. 1 is connected by a strap to the high level input ch. 1. The sound on sound switch is set to the position S-on-S, and both playback volume controls are turned up to maximum. The microphone is connected to the input Mic. 2. The record gain control ch. 2 (lower knob) is adjusted to maximum recording level from the microphone with the push-button II depressed. This is a test recording and the tape is not moving. The record level ch. 2 is now pre-set and should not be touched during the recording.

A test recording of programme I is made with the push-button II, III, and IV depressed and with the microphone plug removed to prevent unwanted signals to disturb the test recording. The record gain control ch. 1 (upper knob) is adjusted to maximum recording level. The record gain ch. 1 is now pre-set and should not be touched during recording.

The pre-recorded programme on ch. 1 is played back through the playback pre-amplifier and the cathode follower ch. 1 and fed to the high level input ch. 1 by the strap. The recording level of the programme is set by the record gain control ch. 1.

The two outputs from the record pre-amplifiers are interconnected. The pre-recorded programme and the programme from the microphone through the record pre-amplifier ch. 2 are both fed to the input of the record amplifier and the record head ch. 2.

Both programmes are connected to the input of the cathode follower ch. 2 from the input of the record amplifier ch. 2 through the push-button V. We are monitoring the sound on sound recording in A-test.

The input of the cathode follower ch. 2 will be connected to the output from the playback pre-amplifier ch. 2 by depressing the push-button V. We are monitoring the sound on sound recording in B-test.

Rewind the tape to the beginning of the pre-recorded programme. Reinsert the microphone plug to the input mic. 2 and start the final recording. Make sure that the push-buttons II, III, and IV are depressed.

The programmes 1 and 2 will now be reproduced through the cathode follower output ch. 1 in A-test. The programmes will be reproduced in B-test by depressing the push-button V.

The playback volume is adjusted by the playback volume control ch. 2 (lower knob).

5.2.11 Echo effects

Ref. block diagram fig. 51.

A limited possibility of echo effect is obtainable during monaural recording.

We presume that the recording is to take place on ch. 1 (upper track). The push-button I and IV are depressed and the sound on sound switch is set to the position S-on-S.

The signal passes through the record pre-amplifier ch. 1 and the record amplifier ch. 1 to the record head. The output from the playback pre-amplifier ch. 1 is connected to the input of the cathode follower ch. 1 through the push-button IV. We are monitoring the recorded signal from the tape through ch. 1 in B-test. The output from the record pre-amplifier ch. 1 is connected to the input of the cathode follower ch. 2 through the push button V. We are monitoring the input signal through ch. 2 in A-test.

We are listening to a programme reproduced as an A-test through ch. 2 and as a B-test through ch. 1. The output levels can be adjusted by the output volume controls.

The delay between the two reproduced signals is determined by the mechanical distance between the record and the playback heads and by the tape speed. Minimum obtainable delay is 150 m.s. at 7½ i.p.s. tape speed. The echo effect is only present during the actual recording and will not be recorded on the tape. A recorded echo effect is obtained by connecting the output from the cathode follower ch. 1 to the high level input of the record pre-amplifier ch. 2. The switches should be set to the same position as outlined above.

The delayed B-test signal from the output of the cathode follower ch. 1 is fed through the record pre-amplifier ch. 2 to the input of the record amplifier ch. 1 and mixed with the input signal. Both signals are recorded on ch. 1. The degree of echo effect is adjusted by the record gain control ch. 2.

5.3 HEAD ALIGNMENT AND TRACK CONTROL WITH TANDBERG TEST TAPES

5.3.1 Model 64

1. Play back the test tape No. 1. This is a full track pre-recorded tape with 1000 c/s recorded at 7½ i.p.s. tape speed. The record level of the exact area corresponding to track 3 is reduced 30 dB. Adjust the height of the playback head until minimum output is obtained on a VTVM from track 3 (ch. 2).
2. Play back the test tape No. 2. This is a full track pre-recorded tape with 10 000 c/c at 7½ i.p.s. tape speed. Adjust the azimuth position of the playback head until maximum reading is obtained on both output meters. Check the lateral position of the playback head by pulling the pressure pad (59.5) away from the erase head when the test tape No. 2 is played back. The output level should not decrease more than 3 dB. Adjust the lateral position of the playback head, if necessary, by turning the head mounting plate.
3. Play back the test tape No. 3. This is a full track pre-recorded tape with the following frequencies: 250 - 10 000 - 5000 - 1000 - 100 - 50 - 250 c/s recorded at 7½ i.p.s. tape speed. The tape conforms with the N.A.B. standards. The output tolerance is ± 2 dB for all frequencies. The difference in level between the two channels should be less than 3 dB.
4. Play back the test tape No. 4 with the output volume controls to maximum. This is a full track pre-recorded tape with 400 c/s at 7½ i.p.s. tape speed. Adjust the potentiometers R233 (ch. 1) and R234 (ch. 2) until the reading on the output meters are 1,5 V.
5. Record a 10 000 c/s signal on both channels in B-test. Adjust the azimuth of the record head to maximum reading on the output meter. Check the lateral position of the record head by pulling the pressure pad (59.5) away from the erase head during the recording. The output level should not decrease more than 3 dB. Adjust the lateral position of the record head, if necessary, by turning the head mounting plate.

6. The record head is set in a preliminary position where approx. 0.1 mm (.0025") of the lamination for the upper track is visible above the tape. The position of the record head can be inspected by using the iron powder method (Magna-See). Record all four tracks on the tape and dip the tape in the solution. The pattern on the tape will show if the position of the head is correct. Readjust if necessary, and repeat point 5.
7. Record a 400 c/s signal from the generator at maximum recording level in stereo-A-test, with the playback volume controls set to maximum. Adjust the record levels by the record gain controls R109 and R110. Depress the push-buttons IV and V (stereo B-test) and adjust the record current by R115 (ch. 1) and R116 (ch. 2) until the readings on the output-meters show 1,5 V. Adjust R137 (ch. 1) and R138 (ch. 2) until the electronic beam indicators are closing. Release the push-buttons IV and V (stereo A-test) and check that the readings still are 1,5 V on the output meters.
8. Record a 3000 c/s signal from the generator at 20 dB below maximum recording level in stereo B-test. Adjust the bias current by R301 (ch. 1) and R302 (ch. 2) until maximum reading is obtained on the output meters. Record a complete frequency response curve in stereo B-test. Increase the bias slightly if the treble response is too high. Repeat point 7 if the bias settings have been changed.
9. The erase head is set in a preliminary position where approx. 0.25 mm (.01") of the ferrite core for the upper track of the erase head is visible above the tape. Insert the test tape No. 9 and record a 1000 c/s signal from the generator on ch. 2 at maximum recording level. Dip the tape in the Magna-See solution and check that the re-recorded track lies in center of the erased track. Make sure that the erase head does not erase any part of the neighbour-track.

5.3.2 Model 62

All the alignments specified in chapter 5.3.1 are valid for model 62 with the exception of the paragraphs 1 and 6. Paragraph 1 is superceded by the instruction 5.6.3, page 36 and paragraph 6 is superceded by instruction 5.6.2, page 36.

5.4 HEAD ALIGNMENT WITHOUT TANDBERG TEST TAPES

5.4.1 Demagnetizing

Demagnetize the heads and adjacent parts before aligning the heads.

5.4.2 The mounting plate for the heads

The height of the mounting plate for the heads (15.4) is aligned by the adjustment screw at the rear of the playback head. Move the operating lever slowly to normal forward drive with a tight tape inserted. Align the height of the mounting plate for the heads until the tape runs equidistant from the flanges of the tape guide (79.2). Ref. fig. 10.

5.4.3 The adjustable tape guide

Set the operating lever in normal forward drive with tape inserted and depress the push-button III. Align the adjustable tape guide (79.3) until the tape runs equidistant from the flanges of the adjustable tape guide. Ref. fig. 10. Repeat 5.4.2.

5.4.4 The playback head

The height alignment:

The height of the playback head is aligned by the height adjustment screws. Ref. fig. 10. The upper edge of the tape shall run flush with the upper part of the airgap for channel 1. Ref. chapters 5.5.3 and 5.6.3 for track control of the playback head.

The azimuth alignment:

Play back a standard azimuth alignment tape with a VTVM connected to each cathode follower output. Adjust the position of the playback head by the azimuth adjustment screw, ref. fig. 10, until maximum reading is obtained on the output meters.

The lateral alignment:

Pull the pressure pad (59.5) away from the erase head when the standard azimuth alignment tape is being played back. The output level should not decrease more than 3 dB. Adjust the lateral position of the playback head, if necessary, by turning the head mounting plate.

5.4.5 The record head

The height alignment:

The height of the record head is aligned by the height adjustment screws. Ref. fig. 10. Approx. 0.1 mm (.0025") of the lamination of the upper track on the record head should be visible above the tape. Ref. chapters 5.5.1 and 5.6.2 for track control of the record head.

The azimuth alignment:

The azimuth position of the record head is adjusted parallel to the correctly adjusted playback head. Record a 10 000 c/s signal from a generator at maximum recording level in stereo B-test with a VTVM connected to each cathode follower output. Adjust the position of the record head by the azimuth adjustment screw, ref. fig. 10, until maximum reading is obtained on the output meters.

The lateral alignment:

Record a 10 000 c/s signal in stereo B-test at maximum recording level. The output level should not decrease more than 3 dB when the pressure pad (59.5) is pulled away from the erase head. Adjust the lateral position of the record head, if necessary, by turning the head mounting plate.

5.4.6 The erase head

The height alignment:

The height of the erase head is aligned by the height adjustment screws. Ref. fig. 10. Approx. 0.25 mm (.01") of the ferrite core for the upper track of the erase head should be visible above the tape. Ref. chapters 5.5.2 and 5.6.1 for track control of the erase head.

The azimuth alignment:

Align the azimuth position of the erase head by the azimuth adjustment screw. Ref. fig. 10. The erase head should be parallel with the mounting plate for the heads (15.4). The azimuth position of the erase head is not critical.

The lateral alignment:

Turn the head mounting plate for the erase head, until the front of the head is parallel to the pressure pad.

5.5 TRACK CONTROL, MODEL 64 WITHOUT TANDBERG TEST TAPES

5.5.1 The record head

Record a 1000 c/s from a generator at maximum recording level in stereo A-test on track 1 and 3 (push-

buttons I, II, and III depressed) for approx. 5 seconds. Turn the tape around and make a similar recording on track 4 and 2. Cut the tape and dip it in a mixture of iron powder and alcohol (Magne-See) to make the recording visible. The spaces between the recorded tracks should be distributed equidistant across the tape. Readjust the height position, if necessary, and recheck the azimuth alignment.

5.5.2 The erase head

Insert a full-track pre-recorded tape and record a 1000 c/s signal from a generator at maximum recording level in mono A-test on track 3 (push-buttons II and III depressed). Cut the tape and dip it in the Magne-See solution. Check that the re-recorded track is in the center of the erased area. Adjust the vertical pos. of the erase head if necessary.

5.5.3 The playback head

Record a 1000 c/s signal on track 1 (ch. 1) and a 500 c/s signal on track 3 (ch. 2) at maximum recording levels. Turn the tape around and play back track 2 (push-buttons III and V depressed) at maximum volume. No signal should be heard. Raise the playback head if the 1000 c/s signal is heard. Lower the playback head if the 500 c/s signal is heard. Re-check the azimuth position.

5.6 TRACK CONTROL, MODEL 62 WITHOUT TANDBERG TEST TAPES

5.6.1 The erase head

The height of the erase head is aligned by the height adjustment screws. Ref. fig. 10. The tape shall run equidistant from the upper and the lower edge of the ferrite core.

For the azimuth and the lateral alignments ref. chapter 5.4.6.

5.6.2 The record head

The height of the record head is aligned by the height adjustment screws. Ref. fig. 10. Record a 1000 c/s signal in stereo (push-buttons I, II, and III depressed) at maximum recording level on a full-track pre-recorded tape. Dip the tape in the Magne-See solution and check that the tracks are distributed symmetrically across the tape, and that the pre-recorded zone remains in the center of the erased zone. Readjust the erase and the record heads, if necessary.

For the azimuth and the lateral alignments ref. chapter 5.4.5.

5.6.3 The playback head

The height of the playback head is aligned by the height adjustment screws. Ref. fig. 10. The tape shall run flush with the upper edge of the lamination for channel 1.

For the azimuth and the lateral alignments ref. chapter 5.4.4.

5.7 ELECTRICAL ADJUSTMENTS

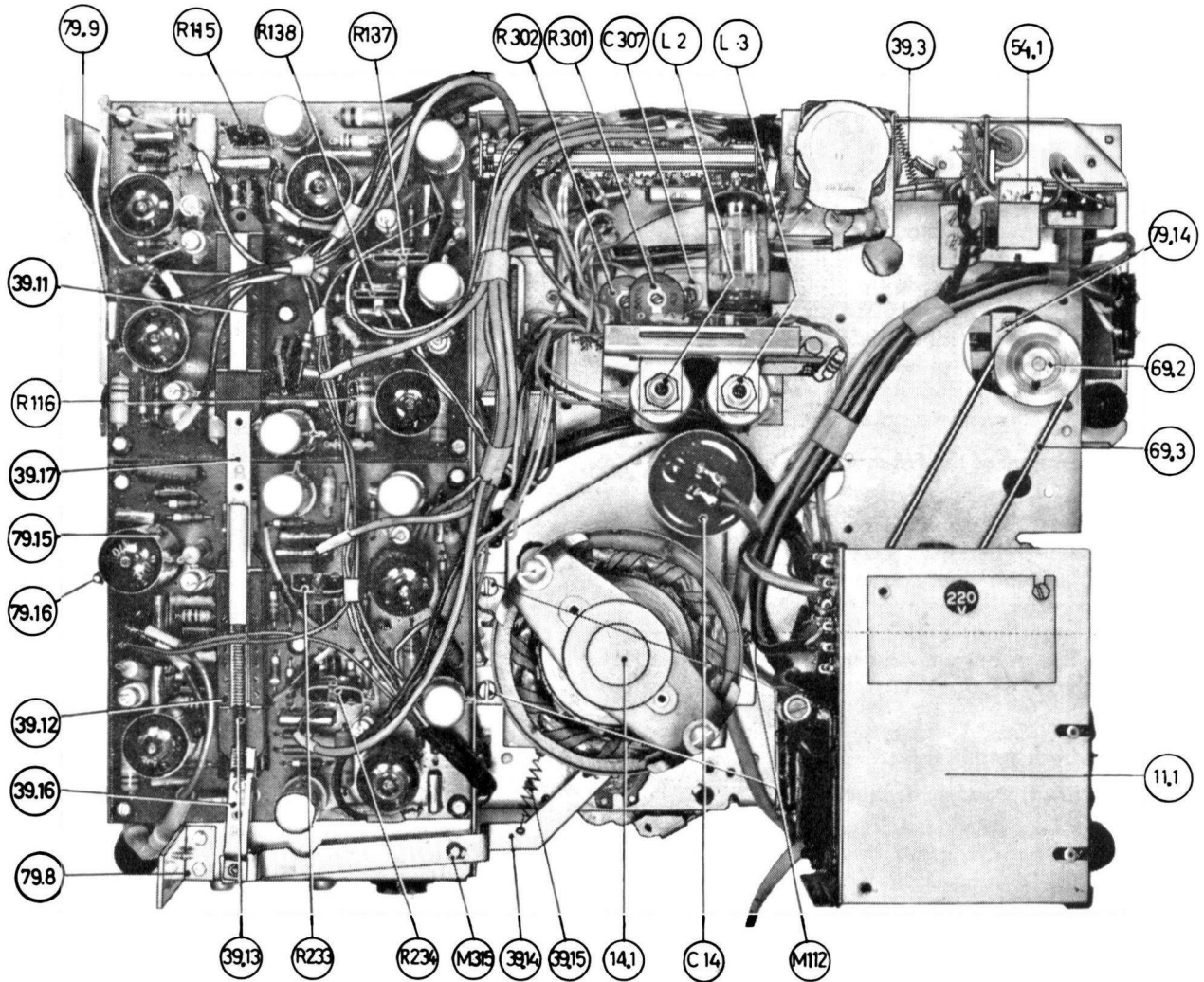

Fig. 54. Bottom view of tape recorder equipped with Engel motor and transformer 11.1-273-6C.

5.7.1 Adjustment of the oscillator and the suppressor coils

Ref. fig. 54 and 59.

Depress the push-buttons I and III, and set the operating lever to normal forward drive. Use a calibrated grid-dip meter and adjust the core of the oscillator coil L1 to a frequency of 78 kc/s. Connect a VTVM to point 51 on the indicator board. Adjust the suppressor coil L2 to minimum reading on the VTVM. The reading should be less than 150 mV.

Depress the push-buttons I, II, and III and set the operating lever to normal forward drive. Connect a VTVM to point 51 on the indicator board. Adjust the variable capacitor C307 to minimum reading on the VTVM. The reading should be less than 150 mV.

Depress the push-buttons I, II, and III and set the operating lever to normal forward drive. Connect a VTVM to point 52 on the indicator board. Adjust the suppressor coil L3 to minimum reading on the VTVM. The reading should be less than 150 mV.

5.7.2 Bias adjustment

Ref. fig. 54 and 58.

Record a 3000 c/s signal from a generator at 20 dB below maximum recording level in stereo B-test (push-buttons I, II, III, IV, and V depressed), with a VTVM connected to each output.

Adjust the potentiometers R301 and R302 on the oscillator board for maximum reading on both meters.

5.7.3 Adjustment of the recording current, the indicators and the AB-test

Ref. fig. 54.

The tape recorder is set up for stereo recording A-test (push-buttons I, II, and III depressed with the operating lever in normal forward drive position) at 7½ ips tape speed. Insert a good quality recording tape. A VTVM is connected to each output terminal. The signal generator is connected to the high level inputs of both channels and tuned to 400 c/s. Adjust the recording gain controls until the readings on the output meters are 1.5 V with the playback volume controls to maximum.

Replace the VTVM for channel 1 with a distortion meter and depress the push-button IV (B-test ch. 1). Adjust the recording current by R115 until the reading shows 3 % distortion.

Replace the VTVM for channel 2 with the distortion meter and depress the push-button V (B-test ch. 2). Adjust the record current by R116 until the reading shows 3 % distortion.

Adjust R137 (ch. 1) and R138 (ch. 2) until the electronic beam indicators are closing.

Connect a VTVM to each output terminal and proceed the recording as described above in stereo B-test with all push-buttons depressed.

Adjust the R233 (ch. 1) and R234 (ch. 2) until the reading on the output meters are 1,5 V. Make sure that the playback volume controls are set to maximum. Release the push-buttons IV and V (stereo A-test) and check that the reading on the output meters still are 1,5 V.

5.7.4 Adjustment of the FM-multiplex filter

Ref. fig. 32 and 40.

Feed a 19 000 c/s signal to both FM-MX inputs and depress the push-buttons I and II. Set the S-on-S switch to A-B test and the playback volume controls to maximum. The recording gain controls should be set to maximum recording level. Connect a VTVM to each cathode follower output. Adjust the core of L4 (ch. 1) and L5 (ch. 2) for minimum reading on the output meters.

5.7.5 Playback amplifier test

With the N.A.B. standard frequency tape

Insert the N.A.B. standard frequency tape and connect a VTVM to each output. Depress the push-buttons III, IV, and V (stereo playback) and set the operating lever to normal forward drive. Use the 250 c/s signal as the 0 dB reference point with the playback volume controls to maximum. The output tolerance is ± 2 dB for all frequencies. The difference in level between the two channels should be maximum 3 dB at any frequency.

Without the N.A.B. standard frequency tape

Insert a 100 ohm resistor in series with the playback head for the upper track (ch. 1) to ground (red wire). Connect a signal generator across the resistor. Depress the push-button IV (monaural playback ch. 1) and set the operating lever to normal forward drive with the

playback volume control to maximum. The signal generator is tuned to 1000 c/s with an output level of 2 mV. The reading on the output meter is the 0 dB reference point, at $7\frac{1}{2}$ ips tape speed. Check the frequency response according to fig. 44.

Repeat the measurements for the lower track (ch. 2). The output tolerance is ± 2 dB for all frequencies. The difference in level between the two channels should be maximum 3 dB at any frequency.

5.7.5 Record amplifier test

Insert a 1000 ohm resistor in series with the record head for upper track (ch. 1) to ground (black wire). Connect a VTVM across the resistor. The signal generator is connected to the high level input of ch. 1. Depress the push-button I (monaural recording ch. 1) and set the operating lever to normal forward drive. Tune the signal generator to 1000 c/s and turn down the output from the generator 20 dB below maximum recording level. The reading on the output meter is the 0 dB reference point. Check the frequency response according to fig. 42.

Repeat the measurement for the lower track (ch. 2). The output tolerance is ± 2 dB for all frequencies. The difference in level between the two channels should be less than 3 dB at any frequency.

5.7.7 Total record and playback response

The tape recorder is set up for stereo recording B-test (all push-buttons depressed) at $7\frac{1}{2}$ ips tape speed, and with a good quality recording tape inserted. A VTVM is connected to each output terminal. The signal generator is connected to the high level inputs of both channels. Tune the generator to 1000 c/s and turn down the output level from the generator 20 dB below maximum recording level. The readings on the output meters are the 0 dB reference points. Check the frequency response for all speeds according to the specification.

$7\frac{1}{2}$ ips	30–20 000 c/s	(± 2 dB 40–16 000 c/s)
$3\frac{3}{4}$ ips	30–14 000 c/s	(± 2 dB 40–10 000 c/s)
$1\frac{7}{8}$ ips	50–7 000 c/s	(± 2 dB 50–5 000 c/s)

The difference in level between the two channels should be less than 3 dB at any frequency.

Increase the bias slightly if the treble response is too high, by adjusting R301 and R302.

5.8 MODIFICATION OF MODEL 64 TO MODEL 62

The following changes have to be introduced when

the tape recorder is modified from quarter-track to half-track.

PART	MODEL 64	MODEL 62
Erase head	15 H	25 H
Record head	16 H	19 H
Playback head	17 H	20 H
C117	.022 μ F, 400 V	.01 μ F, 400 V
C118	.022 μ F, 400 V	.01 μ F, 400 V
For tape recorders with ser. No. lower than 661001:		
R303	120 Kohm, $\frac{1}{2}$ W, 10 %	100 Kohm, $\frac{1}{2}$ W, 10 %
R304	120 Kohm, $\frac{1}{2}$ W, 10 %	100 Kohm, $\frac{1}{2}$ W, 10 %

5.9 INTRODUCTION OF ECC81 (V3 - V4)

The tubes ECC83 (12AX7) have been replaced by 661001. The following changes have to be introduced in the circuit.

PART	WITH TUBE ECC83 (12AX7)	WITH TUBE ECC81 (12AT7)
V3	ECC83 (12AX7)	ECC81 (12AT7)
V4	ECC83 (12AX7)	ECC81 (12AT7)
R129	510 ohm, ½ W, 10 %	390 ohm, ½ W, 10 %
R130	510 ohm, ½ W, 10 %	390 ohm, ½ W, 10 %
R135	10 kohm, ½ W, 10 %	2 kohm, ½ W, 10 %
R136	10 kohm, ½ W, 10 %	2 kohm, ½ W, 10 %
R303-62	100 kohm, ½ W, 10 %	82 kohm, ½ W, 10 %
R304-62	100 kohm, ½ W, 10 %	82 kohm, ½ W, 10 %
R303-64	120 kohm, ½ W, 10 %	82 kohm, ½ W, 10 %
R304-64	120 kohm, ½ W, 10 %	82 kohm, ½ W, 10 %

5.10 VERTICAL MOUNTING OF THE MODELS 64 AND 62

Ref. fig. 55.

The models 64 and 62 can be mounted in vertical position when the thrust spring (66.13) is attached, as shown in fig. 55.

The tape reels must be locked in position by the reel holders (65.4) to prevent the reels from falling off the turntables.

Mounting:

Unscrew the screw A and insert the thrust spring 66.13. The delrin knob shall rest on top of the capstan. Tighten screw A. The tension of the spring should be sufficient to prevent any axial movement of the capstan.

Note: The utmost care must be taken during the mounting of the thrust spring, and the screw B should not be touched, to prevent misalignment of the capstan.

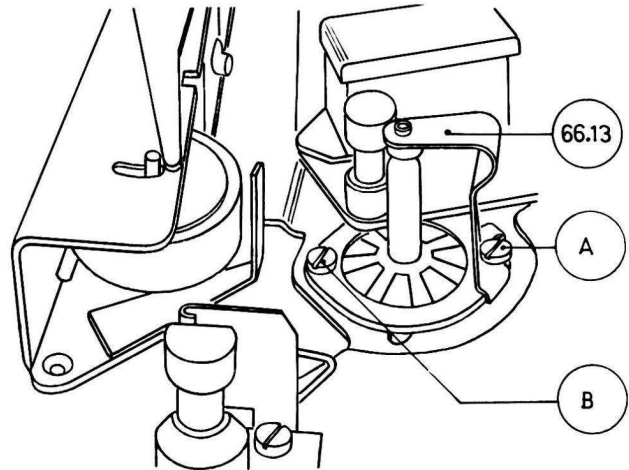

Fig. 55. Mounting of thrust spring 66.13.

6.0 Parts list

To improve the equipment, minor changes and modifications have been introduced on the models 64 and 62. The complete reference number of the part and the serial number of the tape recorder must therefore be specified when spare parts are ordered.

The code for the part reference number:

51.13 - 1 - 6C * Tape brake

1. The three or four first numbers state the part, and are referred to in all figures.

2. This digit is present only when modification is introduced to the part. In some cases, this number also refers to sub contractors specifications.

3. The type number states the type of tape recorder for which the part is used. i.e.
 64 — Parts only for model 64.
 62 — Parts only for model 62.
 6C — The part is interchangeable and used for the models 64 and 62.

4. Modified parts indicated with * may be used as replacement for parts of earlier design.

6.0.1 Mechanical parts

Ref. No.	Description	Fig. ref.	Notes
11.1-273-6C	Power transformer 110—245 V, 50—60 c/s	5, 50, 54	{ Introduced from ser. No. 657001, additional changes ref. chapter 5.1.9
11.1-273-1-6C	Power transformer 110—245 V, 50—60 c/s	5, 50, 54	
11.1-277-6C	Power transformer 110 V, 60 c/s	5, 50, 54	
11.3-6C	Bracket for interlock, complete	50	
14.1-440D-6C	Motor, Papst 440 D	30, 50, 54	
14.1-5030-6C	Motor, Engel	30, 50, 54	
14.2-440D-6C	Mounting plate for Papst motor		
14.2-5030-6C	Mounting plate for Engel motor		
14.3-6C	Rubber mounting		
15.1-64	Record head 16H (quarter-track)	10	
15.1-62	Record head 19H (half-track)	10	
15.2-64	Playback head 17H (quarter-track)	10	
15.2-62	Playback head 20H (half-track)	10	
15.3-64	Erase head 15H (quarter-track)	10	
15.3-62	Erase head 25H (half-track)	10	
15.5-6C	Height adjustment screws for the heads	10	
15.6-6C	Height adjustment screws for the mounting plate for heads	10	
15.7-6C	Azimuth adjustment screws	10	
17.1-6C	Terminal plate with phono jacks ch. 1	50	
17.2-6C	Terminal plate with phono jacks ch. 2	50	
18.1-64	Record amplifier board with components	57	removed from ser. No. 661 000
18.1-1-64	Record amplifier board with components	57	from ser. No. 661 001
18.1-62	Record amplifier board with components	57	removed from ser. No. 661 000
18.1-1-62	Record amplifier board with components	57	from ser. No. 661 001
18.2-6C	Playback amplifier board with components	56	
18.4-6C	Tube socket (all tubes)		
19.1-273-6C	Fuse board for transformer 273		
19.1-277-6C	Fuse board for transformer 277		
19.2-6C	Soldering strip, record head	10	
19.3-6C	Soldering strip, playback head	10	
19.4-6C	Soldering strip, erase head	10	
22.1-6C	Oscillator board with components	58	
22.1-1-6C	Oscillator board with components	58	from ser. No. 657001
22.2-1-6C	Subchassis for oscillator board		from ser. No. 657001
24.1-6C	FM-multiplex filter, complete		
31.1-6C	Indicator board with components	59	
31.2-6C	Spring for indicator tubes	5	
32.2-6C	Double knob, record gain control	37	
32.4-6C	Double knob, playback volume control	37	
32.14-6C	Felt washer		
33.1-6C	Start-stop magnet, complete	34	
33.5-6C	Microswitch for operating lever	6	
33.6-6C	Plate spring, microswitch		removed from ser. No. 657001
33.7-6C	Actuator lever, microswitch		removed from ser. No. 657001
33.7-1-6C	Delrin actuator lever, microswitch	6	from ser. No. 657001
33.9-6C	Line switch (ON-OFF)	8, 5	
33.11-6C	Slip-on knob, line switch		
33.12-6C	3 prong socket, remote control	50	
33.16-6C	Microswitch for end stop	8	
39.1-6C	Push-button center	5	
39.2-6C	Arm, record lock		
39.3-6C	Spring, record-lock arm	54	
39.4-6C	Sound-on-sound switch		
39.5-6C	Lever, sound-on-sound switch	37	
39.6-6C	Muting switch	8	
39.8-6C	Spring, muting switch	8	
39.11-6C	Equalization switch, record amplifier	54	
39.12-6C	Equalization switch, playback amplifier	54	
39.13-6C	Spring, equalization switch	54	

Ref. No.	Description	Fig. ref.	Notes
39.14-6C	Arm, equalization switch	54	
39.15-6C	Spring, equalization switch arm	54	
39.16-6C	Joint plate, equalization arm	54	
39.17-6C	Joint plate	54	
44.1-6C	Pilot lamp, 6.3 Volts		
44.2-6C	Socket, pilot lamp		
45.1-6C	Microphone jack TJA22	5	
45.1-1-6C	Microphone jack J 412 A	5	from ser. No. 665001
48.1-6C	Wooden case		
48.2-6C	Buffer, polyethylen		
51.1-6C	Pressure wheel	9, 10, 30	
51.2-6C	Shaft pressure wheel	9, 10, 30	
51.3-6C	Pressure wheel bracket complete	9	
51.4-6C	Spring, pressure wheel	9, 34	
51.5-6C	Lever, pressure wheel	10, 34	
51.6-6C	Shaft, pressure wheel lever	34	
51.7-6C	Equalization latch	9, 10, 34	
51.8-6C	Start-stop lever	34	
51.9-6C	Roller for pressure wheel bracket	8	
51.12-6C	Spring for pressure wheel bracket	8	
51.13-1-6C*	Tape brake	10, 34	from ser. No. 657001
51.15-6C	Brake block for tape brake		
52.1-6C	Trip bar	11, 20-29	
52.2-6C	Extension spring, lifting arm	11, 5	
53.1-6C	Speed transfer wheel	11, 5, 33	
53.2-6C	Transfer wheel holder	11, 33	from ser. No. 669722
53.2-1-6C	Transfer wheel holder	11, 33	from ser. No. 657001
53.2-2-6C	Transfer wheel holder	11, 33	
53.3-6C	Mounting arm for speed transfer wheel	11, 33	
53.3-1-6C	Mounting arm for speed transfer wheel	11, 33	from ser. No. 669722
53.4-6C	Knob, speed selector	33, 37	
53.5-6C	Spring, transfer wheel holder (set = 2 springs)	11, 33	
53.5-1-6C	Spring transfer wheel holder	11, 33	from ser. No. 657001
53.5-2-6C	Spring, transfer wheel holder	11, 33	from ser. No. 669722
53.7-6C	Parallel arm, complete	11	from ser. No. 669722
54.1-1-6C*	Operating lever, complete	54	
54.2-6C	Operating lever shaft with delrin ball	6	
54.3-6C	Knob, operating lever	37	
54.11-6C	Clip for operating lever	6	
54.13-6C	Spacer for microswitch operating lever		removed from ser. No. 657001
59 1-6C	Eccentric segment	8	
59.2-6C	Shaft eccentric segment (Stud)		
59.4-6C	Pressure pad arm	10, 34	
59.6-6C	Spring for pressure pad arm	34	
59.7-6C	Upper clutch lever for take-up turntable	11, 15, 16, 21, 23, 25, 27, 29	
59.8-6C	Lower clutch lever for take-up turntable	11, 15, 16, 21, 23, 25, 27, 29	
59.9-6C	Clutch lever for supply turntable	11, 12, 13, 20, 22, 24, 26, 28	
59.11-6C	Shaft for 59.7-6C	11, 21, 23, 25, 27	
59.12-6C	Spring for 59.7-6C	21, 23, 25, 27, 29	
59.13-6C	Shaft for 59.8-6C	21, 23, 25, 27, 29	
59.14-6C	Spring for 59.8-6C	21, 23, 25, 27, 29	
59.15-6C	Shaft for 59.9-6C	11, 20, 22, 24, 26, 28	
59.16-6C	Spring for 59.9-6C	20, 22, 24, 26, 28	
59.17-6C	Cam disc	5, 33	
59.18-6C	Cam disc arm	11, 5, 33	
59.19-6C	Extension spring, cam disc arm	11, 33	
59.23-6C	Bracket for cam disc arm shaft	33	
59.24-6C	Shaft for cam disc arm		
59.25-6C	Transfer wheel lifting arm, complete	11, 5, 33	
59 26-6C	Transfer bracket	10, 34	
59.27-6C	Spring with felt for pressure pad	10	
59.28-6C	Brake lever for supply turntable, complete	11, 20, 22, 24, 26, 28	

Ref. No.	Description	Fig. ref.	Notes
59.29-6C	Shaft for brake, supply turntable	11, 20, 22, 24, 26, 28	
59.31-6C	Spring for brake lever, supply turntable	20, 22, 24, 26, 28	
59.32-6C	Delrin button for clutch levers	13, 16, 20-29	
61.1-2-6C*	Take-up friction disc	15, 16, 21, 23, 25, 27, 29, 30	
61.2-1-6C	Supply friction disc	12, 13, 14, 20, 22, 24, 26, 28, 30	
61.2-2-6C	Supply friction disc	12, 13, 14, 20, 22, 24, 26, 28, 30	from ser. No. 669051
61.3-6C	Helical compression spring, take-up turntable	13, 15, 21, 23, 25, 27, 29	
61.4-6C	Helical compression spring, supply turntable	12, 20, 22, 24, 26, 28	
61.6-6C	Mylar sheet, take-up friction disc	15	
61.6-1-6C	Mylar sheet, take-up friction disc	15	from ser. No. 669051
61.7-6C	Mylar sheet, supply friction disc	12, 14	
61.7-1-6C	Mylar sheet, supply friction disc	12, 14	from ser. No. 669051
61.8-6C	Fixing ring for mylar sheet take-up turntable	15	
61.9-6C	Tape tight disc	12	
61.9-1-6C	Tape tight disc	12	from ser. No. 669051
61.11-6C	Spring for tape tight disc	12, 14	
62.1-5750-2-6C*	Motor pulley, Papst motor 60 c/s	5, 30, 33	from ser. No. 661001
62.1-5749-4-6C*	Motor pulley, Papst motor 50 c/s	5, 30, 33	from ser. No. 661001
62.1-5346-2-6C*	Motor pulley, Engel motor 60 c/s	5, 30, 33	from ser. No. 661001
62.1-5334-2-6C*	Motor pulley, Engel motor 50 c/s	5, 30, 33	from ser. No. 661001
62.2-6C	Rubber drive belt	5	
65.1-6C	Take-up turntable	15, 5, 21, 23, 25, 27, 29, 30, 31	
65.1-1-6C	Take-up turntable	15, 5, 21, 23, 25, 27, 29, 30, 31	from ser. No. 669051
65.2-6C	Supply turntable	12, 5, 20, 22, 24, 26, 28, 30	
65.2-1-6C	Supply turntable	12, 5, 20, 22, 24, 26, 28, 30	from ser. No. 669051
65.4-6C	Tape reel holder	12	
65.5-6C	Delrin nut		from ser. No. 669051
66.1-6C	Flywheel, complete	5, 33, 33	
66.3-6C	Bushing, flywheel bearing	8, 31	
66.4-6C	Spring for upper flywheel bearing	31	
66.5-6C	Spring for lower flywheel bearing	31	
66.6-6C	Felt ring for flywheel bearings	31	
66.7-6C	Latch for flywheel bearing, upper mounting plate	8, 31	
66.8-6C	Latch for flywheel bearing, upper and lower mounting plate	11, 31	
66.9-6C	Brake spring for flywheel	11, 5	
66.12-6C	Thrust washer	31	
66.13-6C	Trust spring with delrin knob	55	
69.1-6C	Pulley for revolution counter (turntable)	15	
69.1-1-6C	Pulley for revolution counter (turntable)	15	from ser. No. 669051
69.2-1-6C*	Pulley for revolution counter (counter)	54	from ser. No. 657001
69.3-6C	Rubber belt, revolution counter	54	
72.1-6C	Flange for take-up turntable housing	15	
72.2-6C	Flange for supply turntable housing	12, 14	
73.1-6C	Front trim cover	37	
73.2-6C	Rear trim cover	37	
73.3-6C	Screw for trim cover	37	
73.4-6C	Bracket for front trim cover, left	37	
73.5-6C	Bracket for front trim cover, right	37	
73.6-6C	Bracket for rear trim cover	37	
74.1-64	Top cover model 64	50	
74.1-62	Top cover model 62	50	
74.2-6C	Mounting screw (4 × 24 mm)	5	
74.3-6C	Rubber mounting	5	
74.4-6C	Washer for mounting screw	5	
74.5-6C	Screw for top cover (3 × 8 mm)	37	
74.6-6C	Rubber washer	37	
79.1-6C	Tape guide, left	10	
79.2-6C	Tape guide	10	
79.3-6C	Adjustable tape guide	10	
79.4-6C	Tape guide, right	10, 5	

Ref. No.	Description	Fig. ref.	Notes
79.6-6C	Mounting bracket, left rear	11, 5	
79.7-6C	Mounting bracket, right rear	11, 5	
79.8-6C	Chassis leg, left rear	54	
79.9-6C	Chassis leg, left front	54	
79.11-6C	Speed selector bracket	11, 5, 33	
79.13-6C	Spring, speed selector	33	
79.14-6C	Revolution counter	8, 5, 54	
79.15-6C	Tube shield	54	
79.16-6C	Spring for tube shield	54	
79.17-6C	Hook for tube shield spring		
79.18-6C	Cover plate 1	5	
79.19-6C	Cover plate 2	5	
79.22-6C	Stereo emblem		
79.23-6C	Tandberg emblem		
79.24-6C	Window, revolution counter		
79.25-6C	Window, indicator		
79.26-6C	Spring for fuse holder		
79.27-6C	Rubber mounting tube for printed circuits boards		
79.28-6C	Lock spring for turntables	12, 15	
79.29-6C	Shield for amplifier boards	50	
79.31-6C	Bracket for revolution counter	8	
79.32-6C	Actuating spring for end stop	10, 5	
79.33-6C	Bracket with shaft for actuating spring, end stop		

Screws, washers, and lock washers

M101	Screw 3 × 4 mm c.h.	M121	Screw 2,3 × 12 mm c.h.	M317	Lock ring 5 mm
M102	Screw 3 × 4,5 mm c.h.	M122	Screw 4 × 22 mm c.h.	M318	Lock ring 6 mm
M104	Screw 3 × 6 mm c.h.	M125	Screw 3 × 6 mm c.h. 1.5 mm head	M321	Lock ring 4 × 0,6 mm
M107	Screw 3 × 8 mm c.h.	M301	Turbax washer 7,5 × 4,2 × 0,2 mm	M325	Washer 16 × 4,2 × 1,65 mm
M112	Screw 4 × 6 mm c.h.	M302	Turbax washer 7,5 × 4,2 × 0,3 mm	M329	Lock ring 2,3 mm
M113	Screw 4 × 8 mm c.h.	M303	Turbax washer 7,5 × 4,2 × 0,5 mm	M333	Spring washer 1/8"
M114	Screw 4 × 10 mm c.h.	M313	Lock ring 2,5 mm	M348	Teflon washer 6,5 × 4,2 × 0,2 mm
M116	Parker screw 1/4" No. 4	M314	Lock ring 3 mm	M349	Lock washer 4 mm
		M315	Lock ring 3,5 mm	M403	Rivet 3,5 mm

Coils

L1-6C	Oscillator coil
L2-6C	Suppressor coil ch. 1
L3-6C	Suppressor coil ch. 2
L4-1-6C	FM-MX filter coil ch. 1
L5-1-6C	FM-MX filter coil ch. 2
L6-6C	Coil start/stop magnet

Tubes

V3-1-6C, V4-1-6C	ECC81 (12AT7)
V7-6C, V8-6C, V9-6C	ECC82 (12AU7)
V1-6C, V2-6C, V5-6C, V6-6C	ECC83 (12AX7)
V10-6C, V11-6C	EAM 86

Rectifiers

B250C75-6C	High voltage rectifier
B30C1000-6C	Filament voltage rectifier

Fuses

0.2A-6C, 5 × 30 mm slow	} High voltage
0.2A-6C, 5 × 30 mm slow	
2A-6C, 5 × 30 mm slow	DC filament voltage:
2A-6C, 5 × 30 mm slow	AC filament voltage:

6.0.2 Electrical parts

Resistors

Ref. No.	Description	Type	Notes
R1-6C	1 Mohm 1/2 watt 10 %	Ins. carbon-film SBT	
R2-1-6C	82 000 ohm 1/2 watt 10 %	Ins. carbon-film SBT	from ser. No. 661001
R3-6C	39 000 ohm 1/2 watt 10 %	Ins. carbon-film SBT	
R4-6C	39 000 ohm 1/2 watt 10 %	Ins. carbon-film SBT	
R5-1-6C	82 000 ohm 1/2 watt 10 %	Ins. carbon-film SBT	from ser. No. 661001
R6-6C	1 Mohm 1/2 watt 10 %	Ins. carbon-film SBT	
R7-1-6C	2700 ohm 1/2 watt 10 %	Cracked-carbon	from ser. No. 657001
R8-1-6C	510 ohm 1/2 watt 10 %	Cracked-carbon	from ser. No. 657001
R9-6C	1200 ohm 1/3 watt 10 %	Cracked-carbon	

Ref. No.	Description	Type	Notes
R10-1-6C	2700 ohm 1/2 watt 10 %	Cracked-carbon	from ser. No. 657001
R11-1-6C	4000 ohm 3 watt 10 %	Wire wound CZ00025	from ser. No. 657001
R13-6C	15 000 ohm 3 watt 10 %	Wire wound CZ02038	
R14-6C	1200 ohm 3 watt 10 %	Wire wound CZ00038	
R15-6C	5 ohm 3 watt 10 %	Wire wound CZT00038	
R17-6C	51 ohm 1/2 watt 10 %	Ins. carbon-film SBT	
R18-R19-6C	0,5 Mohm	Double potentiometer T5175	
R20-6C	30 000 ohm 1/2 watt 10 %	Cracked-carbon	
R21-6C	30 000 ohm 1/2 watt 10 %	Cracked-carbon	
R30-6C	39 000 ohm 1/2 watt 10 %	Ins. carbon-film SBT	Equipped only on FM-MX models
R31-6C	39 000 ohm 1/2 watt 10 %	Ins. carbon-film SBT	Equipped only on FM-MX models
R32-1-6C	3300 ohm 1/2 watt 10 %	Ins. carbon-film SBT	Equipped only on FM-MX models
R33-1-6C	3300 ohm 1/2 watt 10 %	Ins. carbon-film SBT	Equipped only on FM-MX models
R34-1-6C	82 000 ohm 1/2 watt 10 %	Ins. carbon-film SBT	Equipped only on FM-MX models
R35-1-6C	82 000 ohm 1/2 watt 10 %	Ins. carbon-film SBT	Equipped only on FM-MX models
R101-6C	5,1 ohm 1/2 watt 10 %	Ins. carbon-film SBT	
R102-6C	5,1 ohm 1/2 watt 10 %	Ins. carbon-film SBT	
R103-6C	10 000 ohm 1/2 watt 10 %	Ins. carbon-film SBT	
R104-6C	10 000 ohm 1/2 watt 10 %	Ins. carbon-film SBT	
R105-6C	2000 ohm 1 watt 10 %	Cracked-carbon	
R106-6C	2000 ohm 1 watt 10 %	Cracked-carbon	
R107-6C	0,1 Mohm 1 watt 10 %	Cracked-carbon	
R108-6C	0,1 Mohm 1 watt 10 %	Cracked-carbon	
R109-R110-6C	0,25 Mohm	Double Potentiometer T5787	
R111-6C	2000 ohm 1/2 watt 10 %	Ins. carbon-film SBT	
R112-6C	2000 ohm 1/2 watt 10 %	Ins. carbon-film SBT	
R113-6C	0,1 Mohm 1 watt 10 %	Cracked-carbon	
R114-6C	0,1 Mohm 1 watt 10 %	Cracked-carbon	
R115-6C	0,25 Mohm	Trimming Potentiometer P4	
R115B-6C	0,15 Mohm 1/2 watt 10 %	Ins. carbon SBT	from ser. No. 657001
R116-6C	0,25 Mohm	Trimming Potentiometer P4	
R116B-6C	0,15 Mohm 1/2 watt 10 %	Ins. carbon SBT	
R117-6C	20 000 ohm 1/2 watt 10 %	Cracked-carbon	from ser. No. 657001
R118-6C	20 000 ohm 1/2 watt 10 %	Cracked-carbon	
R119-6C	3900 ohm 1/2 watt 10 %	Ins. carbon-film ABT	
R120-6C	3900 ohm 1/2 watt 10 %	Ins. carbon-film ABT	
R121-6C	0,1 Mohm 1 watt 10 %	Ins. carbon-film ABT	
R122-6C	0,1 Mohm 1 watt 10 %	Ins. carbon-film ABT	
R123-6C	0,51 Mohm 1/2 watt 10 %	Ins. carbon-film SBT	
R124-6C	0,51 Mohm 1/2 watt 10 %	Ins. carbon-film SBT	
R125-6C	0,1 Mohm 1/2 watt 10 %	Ins. carbon-film SBT	
R126-6C	0,1 Mohm 1/2 watt 10 %	Ins. carbon-film SBT	
R127-6C	1 Mohm 1/2 watt 10 %	Ins. carbon-film SBT	
R128-6C	1 Mohm 1/2 watt 10 %	Ins. carbon-film SBT	
R129-1-6C	390 ohm 1/2 watt 5 %	Ins. carbon-film SBT	from ser. No. 661001
R130-1-6C	390 ohm 1/2 watt 5 %	Ins. carbon-film SBT	from ser. No. 661001
R131-6C	82 000 ohm 1 watt 10 %	Ins. carbon-film ABT	
R132-6C	82 000 ohm 1 watt 10 %	Ins. carbon-film ABT	
R133-6C	0,1 Mohm 1/2 watt 10 %	Ins. carbon-film SBT	
R134-6C	0,1 Mohm 1/2 watt 10 %	Ins. carbon-film SBT	
R135-1-6C	2000 ohm 1/3 watt 10 %	Cracked-carbon	from ser. No. 661001
R136-1-6C	2000 ohm 1/3 watt 10 %	Cracked-carbon	from ser. No. 661001
R137-6C	0,5 Mohm	Trimming Potentiometer E097AB	
R138-6C	0,5 Mohm	Trimming Potentiometer E097AB	
R201-6C	0,1 Mohm 1/2 watt 10 %	Ins. carbon-film SBT	
R202-6C	0,1 Mohm 1/2 watt 10 %	Ins. carbon-film SBT	
R203-6C	1 Mohm 1/2 watt 10 %	Ins. carbon-film SBT	
R204-6C	1 Mohm 1/2 watt 10 %	Ins. carbon-film SBT	
R205-6C	2000 ohm 1 watt 10 %	Cracked-carbon	
R206-6C	2000 ohm 1 watt 10 %	Cracked-carbon	
R207-6C	47 000 ohm 1 watt 10 %	Cracked-carbon	
R208-6C	47 000 ohm 1 watt 10 %	Cracked-carbon	

Ref. No.	Description	Type	Notes
R209-6C	1 Mohm 1/2 watt 10 %	Ins. carbon-film SBT	
R210-6C	1 Mohm 1/2 watt 10 %	Ins. carbon-film SBT	
R211-6C	1000 ohm 1/2 watt 10 %	Ins. carbon-film SBT	
R212-6C	1000 ohm 1/2 watt 10 %	Ins. carbon-film SBT	
R213-6C	0,1 Mohm 1 watt 10 %	Cracked-carbon	
R214-6C	0,1 Mohm 1 watt 10 %	Cracked-carbon	
R215-6C	1 Mohm 1/2 watt 10 %	Ins. carbon-film SBT	
R216-6C	1 Mohm 1/2 watt 10 %	Ins. carbon-film SBT	
R217-6C	9100 ohm 1/2 watt 10 %	Ins. carbon-film SBT	
R218-6C	9100 ohm 1/2 watt 10 %	Ins. carbon-film SBT	
R219-6C	18 000 ohm 1/2 watt 10 %	Ins. carbon-film SBT	
R220-6C	18 000 ohm 1/2 watt 10 %	Ins. carbon-film SBT	
R221-6C	27 000 ohm 1/2 watt 10 %	Ins. carbon-film SBT	
R222-6C	27 000 ohm 1/2 watt 10 %	Ins. carbon-film SBT	
R223-6C	39 000 ohm 1/2 watt 10 %	Cracked-carbon	
R224-6C	39 000 ohm 1/2 watt 10 %	Cracked-carbon	
R225-6C	7500 ohm 1/2 watt 10 %	Ins. carbon-film SBT	
R226-6C	7500 ohm 1/2 watt 10 %	Ins. carbon-film SBT	
R227-6C	510 ohm 1/2 watt 10 %	Ins. carbon-film SBT	
R228-6C	510 ohm 1/2 watt 10 %	Ins. carbon-film SBT	
R229-6C	82 000 ohm 1/2 watt 10 %	Ins. carbon-film ABT	
R230-6C	82 000 ohm 1/2 watt 10 %	Ins. carbon-film ABT	
R231-6C	0,68 Mohm 1/2 watt 10 %	Ins. carbon-film ABT	
R232-6C	0,68 Mohm 1/2 watt 10 %	Ins. carbon-film ABT	
R233-6C	0,2 Mohm	Trimming Potentiometer	
R234-6C	0,2 Mohm	Trimming Potentiometer	
R235-6C	51 000 ohm 1/2 watt 10 %	Ins. carbon-film SBT	
R236-6C	51 000 ohm 1/2 watt 10 %	Ins. carbon-film SBT	
R237-6C	1 Mohm 1/2 watt 10 %	Ins. carbon-film SBT	
R238-6C	1 Mohm 1/2 watt 10 %	Ins. carbon-film SBT	
R239-6C	2000 ohm 1/2 watt 10 %	Ins. carbon-film SBT	
R240-6C	2000 ohm 1/2 watt 10 %	Ins. carbon-film SBT	
R241-6C	10 000 ohm 1 watt 10 %	Cracked-carbon	
R242-6C	10 000 ohm 1 watt 10 %	Cracked-carbon	
R243-6C	0,1 Mohm 1/2 watt 10 %	Ins. carbon-film SBT	
R244-6C	0,1 Mohm 1/2 watt 10 %	Ins. carbon-film SBT	
R245-6C	2000 ohm 1/2 watt 10 %	Cracked-carbon	
R246-6C	2000 ohm 1/2 watt 10 %	Cracked-carbon	
R301-6C	0,5 Mohm	Trimming Potentiometer E097AC	
R302-6C	0,5 Mohm	Trimming Potentiometer E097AC	
R303-1-6C	82 000 ohm 1/2 watt 10 %	Ins. carbon-film SBT	from ser. No. 661001
R304-1-6C	82 000 ohm 1/2 watt 10 %	Ins. carbon-film SBT	from ser. No. 661001
R305-6C	51 ohm 1/2 watt 10 %	Ins. carbon-film SBT	
R306-6C	10 000 ohm 1/2 watt 10 %	Ins. carbon-film SBT	
R307-6C	510 ohm 1/2 watt 10 %	Ins. carbon-film SBT	
R309-6C	10 000 ohm 1/2 watt 10 %	Ins. carbon-film SBT	
R401-6C	0,15 Mohm 1/2 watt 10 %	Ins. carbon-film SBT	
R402-6C	0,15 Mohm 1/2 watt 10 %	Ins. carbon-film SBT	
R403-6C	0,15 Mohm 1 watt 10 %	Ins. carbon-film ABT	
R404-6C	0,15 Mohm 1 watt 10 %	Ins. carbon-film ABT	
R405-6C	0,15 Mohm 1 watt 10 %	Ins. carbon-film SBT	
R406-6C	0,15 Mohm 1/2 watt 10 %	Ins. carbon-film SBT	
R407-6C	10 Mohm 1/2 watt 10 %	Ins. carbon-film SBT	
R403-6C	10 Mohm 1/2 watt 10 %	Ins. carbon-film SBT	

Capacitors

Ref. No.	Description	Type	Notes
C1-6C	10 pF 125 volts 5 %	Ceramics	
C2-6C	200 pF 125 volts 10 %	Styroflex	
C3-6C	200 pF 125 volts 10 %	Styroflex	
C4-6C	10 pF 125 volts 5 %	Ceramics	
¹⁾ C5-6C	40 + 20 + 10 μ F 350 volts	Electrolytic	
¹⁾ C6-6C	40 + 20 + 10 μ F 350 volts	Electrolytic	
²⁾ C7-6C	40 + 20 + 10 μ F 350 volts	Electrolytic	
²⁾ C8-6C	40 + 20 + 10 μ F 350 volts	Electrolytic	
C9-6C	1000 + 1000 μ F 30/35 volts	Electrolytic with Ins. sleeve	
C10-6C	250 μ F 30/35 volts	Electrolytic B4101	
²⁾ C11-6C	40 + 20 + 10 μ F 350 volts	Electrolytic	
C12-6C	1000 + 1000 μ F 30/35 volts	Electrolytic with Ins. sleeve	
C13-6C	0,1 μ F 350 AC volts 20 %	Oil paper	
C14-6C	1,5 μ F 380/570 AC volts 10 %	Oil paper	
C15-6C	10 000 pF 400 volts 10 %	Paper W99	
C16-6C	10 000 pF 400 volts 10 %	Paper W99	
¹⁾ C17-6C	40 + 20 + 10 μ F 350 volts	Electrolytic	
C30-1-6C	800 pF 125 volts 2,5 %	Styroflex	Equipped only on FM-MX models from ser. No. 636 301
C31-1-6C	800 pF 125 volts 2,5 %	Styroflex	Equipped only on FM-MX models from ser. No. 636 301
C101-6C	25 μ F 6/8 volts	Electrolytic	
C102-6C	25 μ F 6/8 volts	Electrolytic	
C103-6C	0,022 μ F 400 volts	Metalized paper, miniprint	
C104-6C	0,022 μ F 400 volts	Metalized paper, miniprint	
C105-6C	4000 pF 150 volts 10 %	Paper W99	
C106-6C	4000 pF 150 volts 10 %	Paper W99	
C107-6C	0,047 μ F 400 volts	Metalized paper, miniprint	
C108-6C	0,047 μ F 400 volts	Metalized paper, miniprint	
C109-6C	16 μ F 350 volts	Electrolytic	
C110-6C	16 μ F 350 volts	Electrolytic	
C111-6C	10 000 pF 150 volts 10 %	Paper W99	
C112-6C	10 000 pF 150 volts 10 %	Paper W99	
C113-6C	2000 pF 400 volts 10 %	Paper W99	
	10 000 pF 150 volts 10 %	Paper W99	
	2000 pF 400 volts 10 %	Paper W99	
C114-6C	10 000 pF 150 volts 10 %	Paper W99	from ser. No. 659000
	20 000 pF 150 volts 10 %	Paper W99	from ser. No. 659000
C115-1-6C	20 000 pF 150 volts 10 %	Paper W99	
C116-1-6C	20 000 pF 150 volts 10 %	Paper W99	
C117-64	0,022 μ F 400 volts	Metalized paper, miniprint	from ser. No. 648800
C117-1-62	0,01 μ F 400 volts	Metalized paper, miniprint	
C118-64	0,022 μ F 400 volts	Metalized paper, miniprint	from ser. No. 648800
C118-1-62	0,01 μ F 400 volts	Metalized paper, miniprint	
C119-6C	0,047 μ F 400 volts	Metalized paper, miniprint	
C120-6C	0,047 μ F 400 volts	Metalized paper, miniprint	
C121-6C	100 pF 125 volts 5 %	Styroflex	
C122-6C	100 pF 125 volts 5 %	Styroflex	
C123-6C	65 pF 125 volts 5 %	Styroflex	
C124-6C	65 pF 125 volts 5 %	Styroflex	
C125-6C	200 pF 125 volts 5 %	Styroflex	
C126-6C	200 pF 125 volts 5 %	Styroflex	
C127-6C	16 μ F 350 volts	Electrolytic	
C128-6C	16 μ F 350 volts	Electrolytic	
C129-6C	15 pF 500 volts 5 %	Ceramics	
C130-6C	15 pF 500 volts 5 %	Ceramics	
C131-6C	25 μ F 6/8 volts	Electrolytic	
C132-6C	25 μ F 6/8 volts	Electrolytic	
C133-6C	0,047 μ F 400 volts	Metalized paper, miniprint	
C134-6C	0,047 μ F 400 volts	Metalized paper, miniprint	
C201-6C	200 pF 125 volts	Styroflex	

¹⁾ C5, C6, and C17 in the same can.

²⁾ C7, C8, and C11 in the same can.

Ref. No.	Description		Type	Notes
C202-6C	200 pF	125 volts	Styroflex	
C203-6C	1500 pF	400 volts	Paper W99	
C204-6C	1500 pF	400 volts	Paper W99	
C205-6C	0,022 μ F	400 volts	Metalized paper, miniprint	
C206-6C	0,022 μ F	400 volts	Metalized paper, miniprint	
C207-6C	25 μ F	6/8 volts	Electrolytic	
C208-6C	25 μ F	6/8 volts	Electrolytic	
C209-6C	0,022 μ F	400 volts	Metalized paper, miniprint	
C210-6C	0,022 μ F	400 volts	Metalized paper, miniprint	
C211-6C	0,047 μ F	400 volts	Metalized paper, miniprint	
C212-6C	0,047 μ F	400 volts	Metalized paper, miniprint	
C213-6C	16 μ F	350 volts	Electrolytic	
C214-6C	16 μ F	350 volts	Electrolytic	
C215-6C	500 pF	600 volts 10 %	Paper W99	
C216-6C	500 pF	600 volts 10 %	Paper W99	
C217-6C	0,047 μ F	400 volts	Metalized paper, miniprint	
C218-6C	0,047 μ F	400 volts	Metalized paper, miniprint	
C219-6C	5000 pF	150 volts 10 %	Paper W99	
C220-6C	5000 pF	150 volts 10 %	Paper W99	
C221-6C	0,022 μ F	400 volts	Metalized paper, miniprint	
C222-6C	0,022 μ F	400 volts	Metalized paper, miniprint	
C223-6C	16 μ F	350 volts	Electrolytic	
C224-6C	16 μ F	350 volts	Electrolytic	
C225-6C	2 μ F	70/80 volts	Electrolytic	
C226-6C	2 μ F	70/80 volts	Electrolytic	
C227-6C	10 000 pF	150 volts	Paper W99	
C228-6C	10 000 pF	150 volts	Paper W99	
C301-6C	65 pF	500 volts 5 %	Styroflex	
C302-6C	0,1 μ F	400 volts	Metalized paper, miniprint	
C303-6C	65 pF	500 volts 5 %	Styroflex	
C304-6C	0,01 μ F	400 volts	Metalized paper, miniprint	
C305-6C	125 pF	125 volts 5 %	Styroflex	
C306-6C	125 pF	125 volts 5 %	Styroflex	
C307-6C	50—250 pF		Glimmer Trimming Cond.	
C307B-6C	65 pF	500 volts 5 %	Glimmer	
C308-6C	0,047 μ F	400 volts	Metalized paper, miniprint	
C310-6C	2000 pF	500 volts 2,5 %	Styroflex	
C311-6C	5000 pF	125 volts 2,5 %	Styroflex	
C312-6C	2000 pF	500 volts 2,5 %	Styroflex	
C401-6C	0,01 pF	400 volts	Metalized paper, miniprint	
C402-6C	0,01 pF	400 volts	Metalized paper, miniprint	
C405-6C	0,022 pF	400 volts	Metalized paper, miniprint	
C406-6C	0,022 pF	400 volts	Metalized paper, miniprint	

1 pF = 1 μ pF

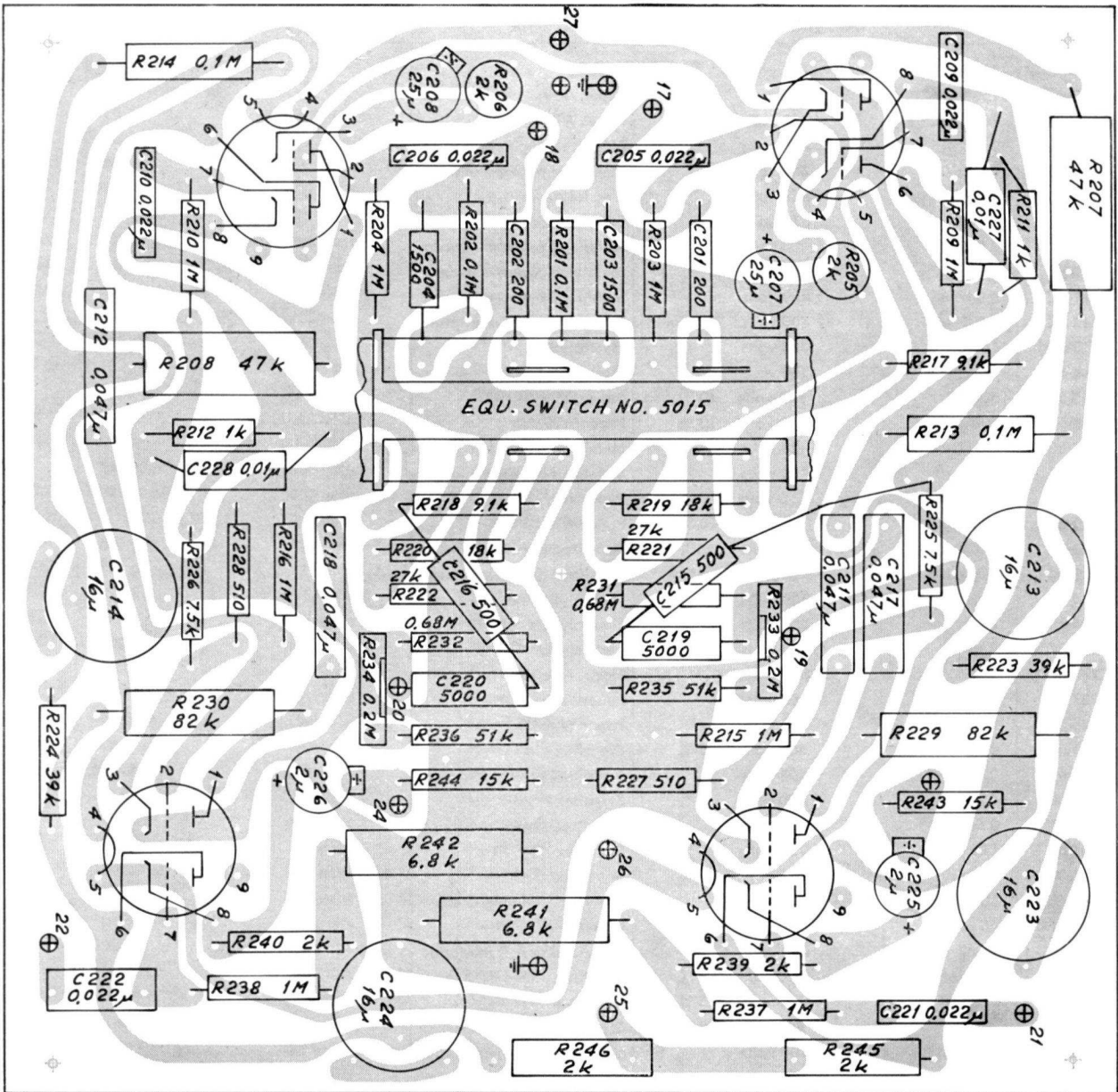

Fig. 56. The playback pre-amplifiers and cathode followers, printed circuit board.

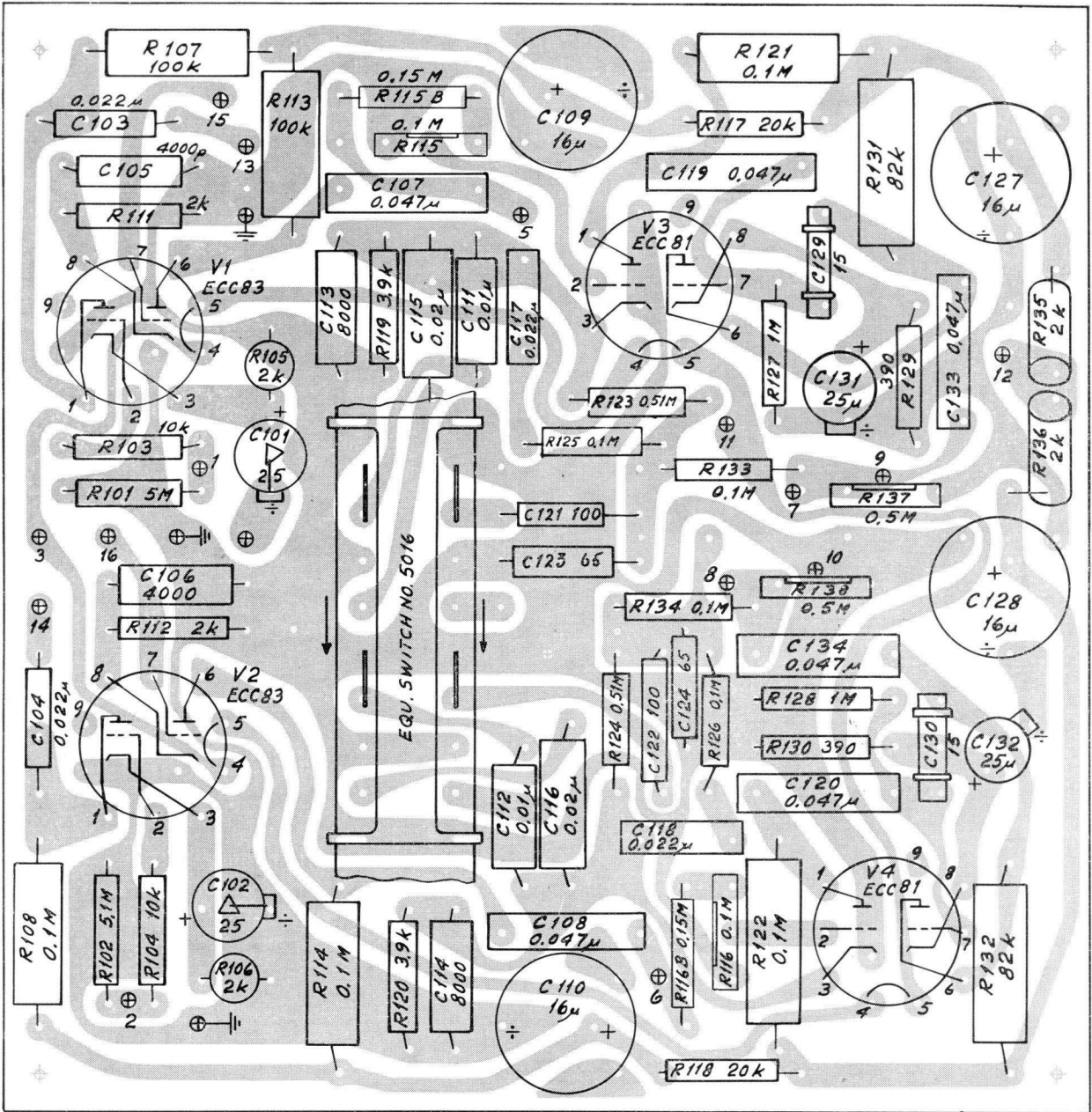

Fig. 57. The record pre-amplifiers and the record amplifiers, printed circuit board.

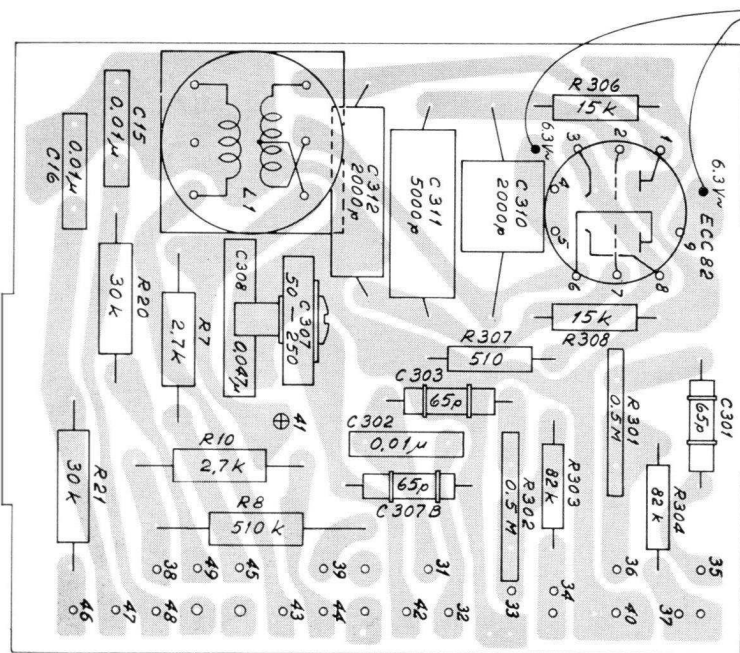

Fig. 58. The oscillator, printed circuit board.

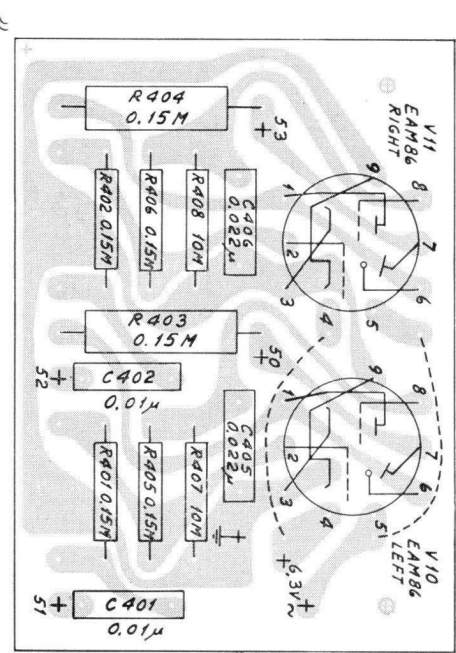

Fig. 59. The indicators, printed circuit board.

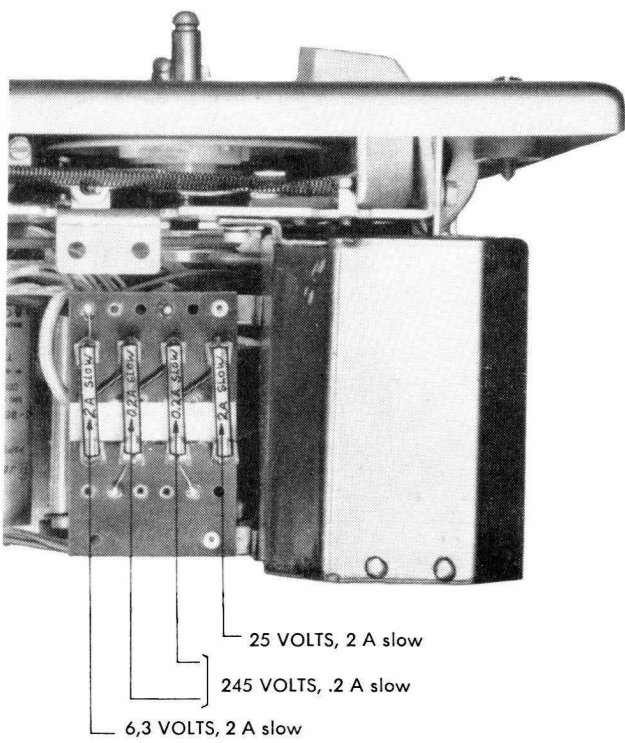

Fig. 60. The position of the fuses, 60 c/s models.

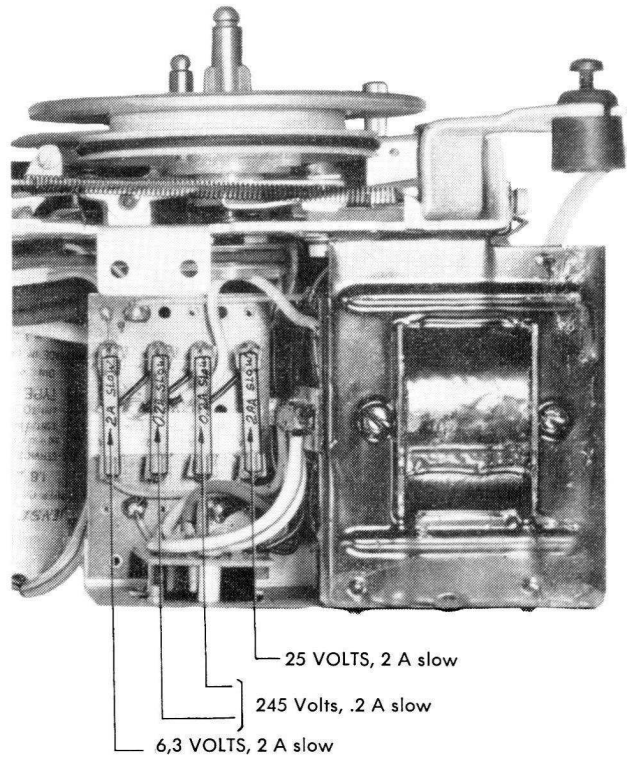

Fig. 61. The position of the fuses, 50 c/s models.

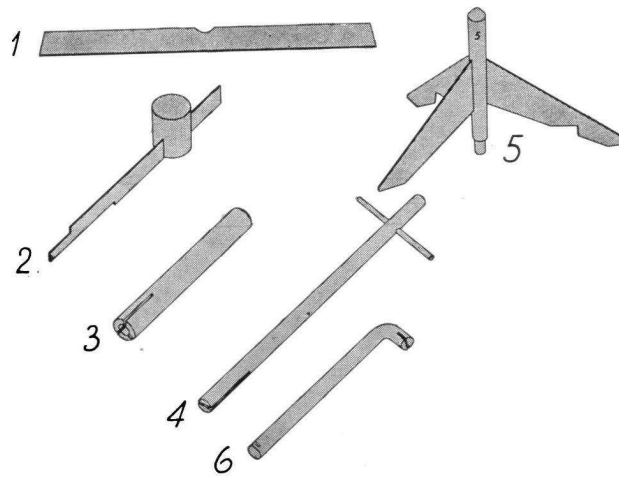
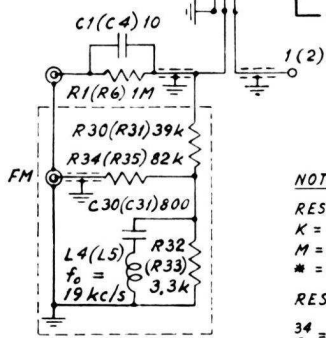
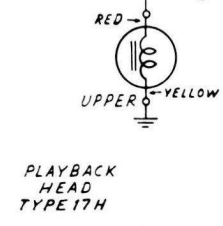
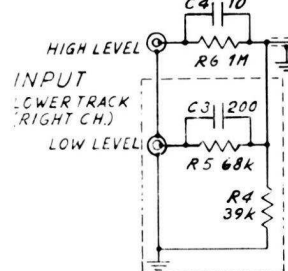
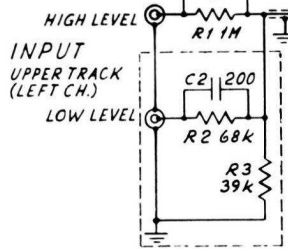
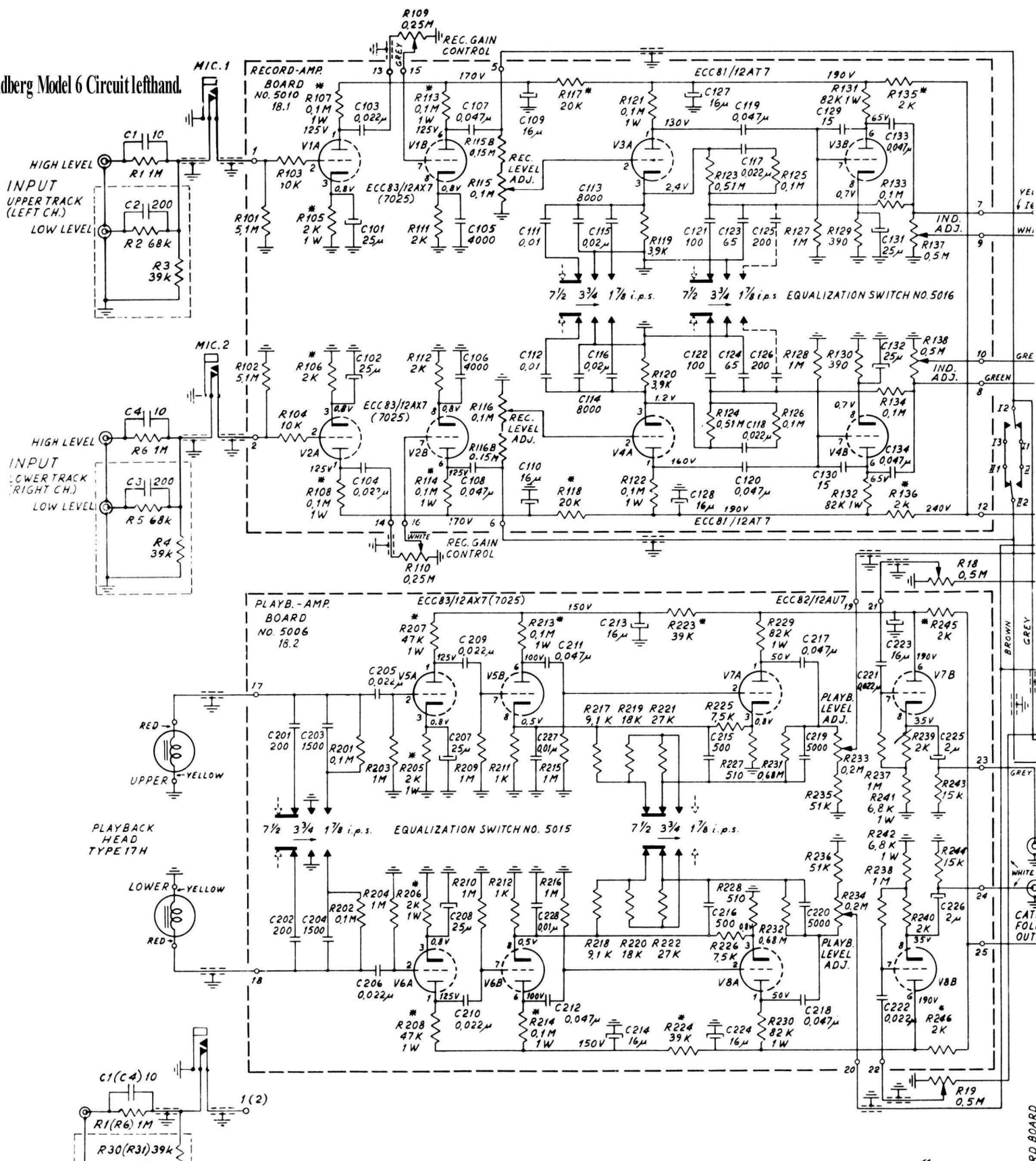

Fig. 62. The special tools.

Tandberg Model 6 Circuit left-hand.



NOTES:
 RESISTORS INDICATED IN OHMS.
 K = 1,000 OHMS.
 M = 1,000,000 OHMS.
 * = DEPOSITED CARBON RESISTORS.
 RESISTORS ± 10% UNLESS OTHERWISE SPECIFIED.
 3/4 = CONNECTION POINTS

CAPACITORS INDICATED IN MICROMICROFARADS UNLESS OTHERWISE SPECIFIED.
 CAPACITORS ± 20% UNLESS OTHERWISE SPECIFIED.
 ALL SWITCHES IN NEUTRAL POSITION.

ALL VOLTAGES MEASURED AT LINE VOLTAGE 110 VOLTS.

RESISTANCE IN ERASE HEAD : ca. 90 OHMS.
 RESISTANCE IN RECORD HEAD : ca. 300 OHMS.
 RESISTANCE IN PLAYBACK HEAD : ca. 250 OHMS.
 RESISTANCE IN L2 AND L3 : ca. 20 OHMS.
 RESISTANCE IN L4 AND L5 : ca. 80 OHMS.

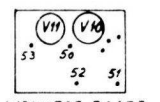
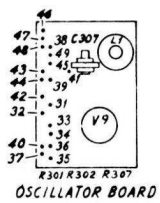

RECORD BOARD
 PLAYBACK BOARD
 ETCHED I

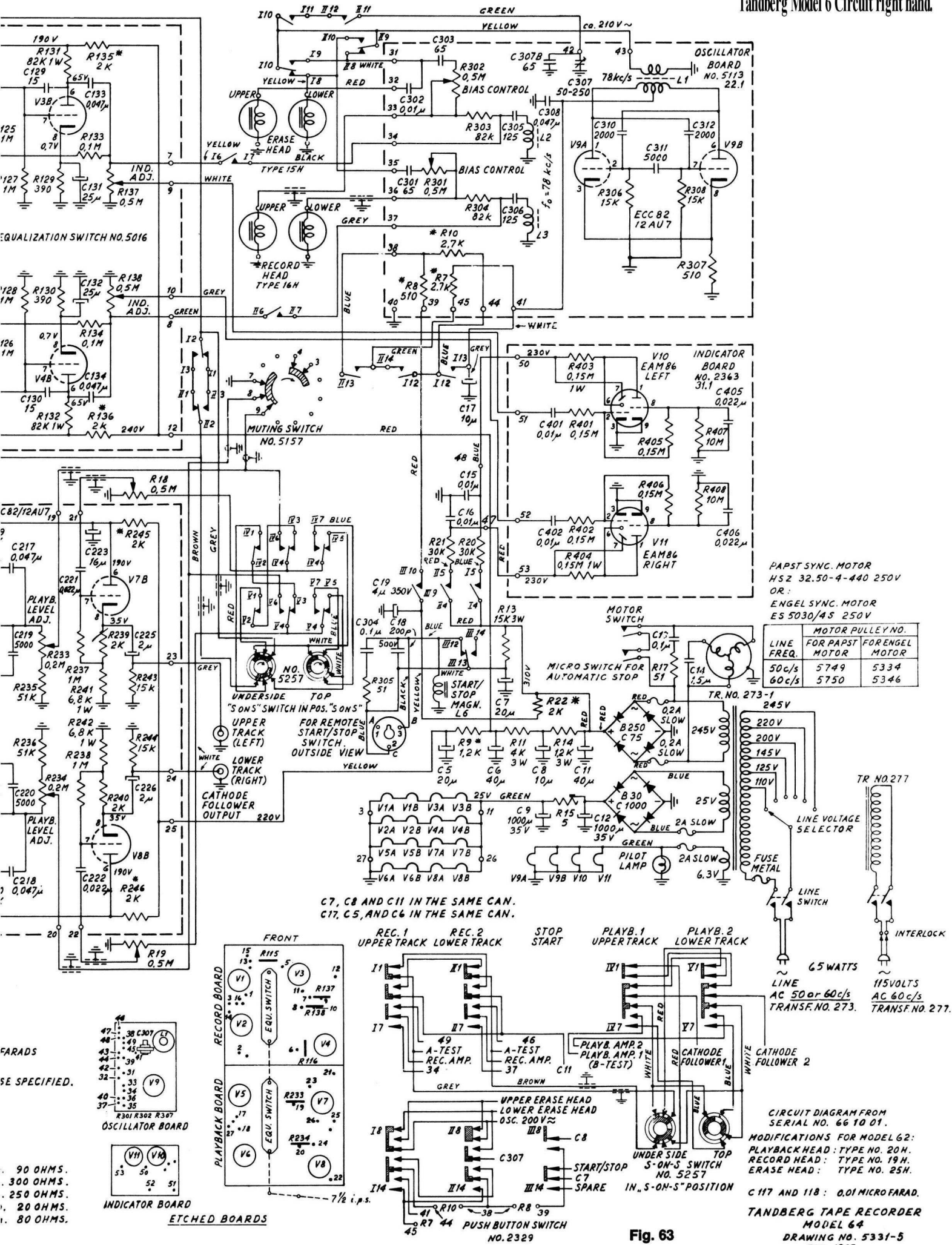

PAPST SYNC. MOTOR
HSZ 32.50-4-440 250V
OR:
ENGEL SYNC. MOTOR
ES 5030/4S 250V

LINE FREQ.	MOTOR PULLEY NO.	
	FOR PAPST MOTOR	FOR ENGEL MOTOR
50c/s	5749	5334
60c/s	5750	5346

C7, C8 AND C11 IN THE SAME CAN.
C17, C5, AND C6 IN THE SAME CAN.

CIRCUIT DIAGRAM FROM SERIAL NO. 66 10 01.
MODIFICATIONS FOR MODEL 62:
PLAYBACK HEAD: TYPE NO. 20H.
RECORD HEAD: TYPE NO. 19H.
ERASE HEAD: TYPE NO. 25H.
C117 AND 118: 0.01 MICROFARAD.
TANDBERG TAPE RECORDER MODEL 64
DRAWING NO. 5331-5
JAN. 1965

Fig. 63

LUBRICATING

The Papst motor:

The Papst motor should be lubricated after every 1500 hours of use. The radial bearings should be lubricated with a Teresso oil 43 or 47 from Esso. Feed the oil into the upper bearing through the slit under the upper bakelite washer. The oil will fill the upper bearing and follow a wick of felt down to the lower bearing. The thrust bearing mounted on the bottom plate of the motor should be lubricated with a SAE 80 hypoid oil.

The Engel motor:

The Engel motor should be lubricated after approx. every 3000 hours of use. The upper and the lower bearing should be lubricated with a Teresso oil 43 or 47 from Esso.

The self-lubricating bearings:

The turntables, the flywheel and the speed transfer wheel are mounted in self-lubricating bearings and should usually not be lubricated. If, however, it should be necessary to lubricate the bearings for any reason use Teresso oil 43 or 47 from Esso.

Note: Utmost care must be taken while lubricating, use only one fraction of a drop of oil for each bearing. Excessive oil might seriously affect the friction drive.



J. Petlitz Boktrykkeri (Rolf Rannem), Oslo