

TANDBERG TAPE-RECORDER

Models 64x and 62x

Alignment instruction
for
heads and electronics

Preface

The models 64x and 62x are improved versions of the earlier models 64-62 and this alignment instruction is an appendix to the service manual for model 64-62. It covers the special head alignments and electrical adjustments necessary for model 64x and 62x.

The models 64x and 62x have the same operation facilities as 64-62. A new, and separate bias head

has been introduced to improve the frequency response and the signal to noise ratio.

The oscillator has been redesigned and fully transistorized. Certain minor changes have been introduced in the equalization circuits, mainly changes of component values. A microswitch is further introduced in the bias circuit to reduce the bias in 1.7/8 i. p. s. tape speed. This switch is operated automatically by the speed selector mechanism. See fig. 3.

Tandberg
RADIO

1.0 Alignment

It is important that the contact between the tape and the heads on the tape recorder is good. To obtain this contact the tape should be run through the tape recorder 5–10 times at normal speed to have the tape polished before measuring the frequency response and the signal to noise ratio.

1.0.1 Demagnetizing

Demagnetize the heads and adjacent parts before aligning the heads.

1.0.2. The mounting plate for the heads

The height of the mounting plate for the heads (15.4) is aligned by the adjustment screw at the rear of the playback head. Move the operating lever slowly to normal forward drive with a tight tape inserted. Align the height of the mounting plate for the heads until the tape runs equidistant from the flanges of the tape guide (79,2).

1.0.3 The adjustable tape guide

Set the operating lever in normal forward drive with tape inserted and depress the push-button III. Align the adjustable tape guide (79.3) until the tape runs equidistant from the flanges of the adjustable tape guide. Repeat 1.0.2.

2.0 Adjustment of the oscillator and bias head circuits.

2.0.1 Insert one 10 ohm resistor in series with each bias head half to ground and connect a V.T.V.M. across each resistor.

2.0.2 R 609 and R 612 is turned up to 1 o'clock position while R 607 and R 610 are set to approx. 11 o'clock. Ref. fig. 3.

2.0.3 Set the tape recorder to stereo recording and the speed selector to $7\frac{1}{2}$ i.p.s.

2.0.4 Use a calibrated long wave receiver, frequency meter or frequency counter for the indication and adjust the oscillator frequency by C 610 until $f_{osc} = 85.5$ kc/s.

2.0.5 Set the tape recorder for mono recording CH 1 and the speed selector to $7\frac{1}{2}$ i.p.s.

2.0.6 Adjust the oscillator frequency with L 601

f_{osc} will then be 85.5 kc/s.

2.0.7 Set the tape recorder for mono recording CH 2.

2.0.8 Readjust L 601 to compromise if necessary. The osc. frequency deviation between mono recording CH 1, CH 2 and stereo should be less than 2 kc/s. The deviation should be indicated with frequency meter, long wave receiver or frequency counter.

2.0.9 Adjust C 602 and 604 to max. reading on the V.T.V.M. (between 100 mV and 400 mV).

3.0 Head alignment and track control with Tandberg Test Tapes, Model 64x

3.1. The playback head

3.1.1 Connect one V.T.V.M. to each CATHODE FOLLOWER output.

3.1.2 Height alignment:

Play back the test tape No. 1. This is a full track pre-recorded tape with 1000 c/s recorded at $7\frac{1}{2}$ i.p.s.

tape speed. The record level of the exact area corresponding to track 3 is reduced 30 dB. Adjust the height of the playback head until minimum output is obtained on a V.T.V.M. from track 3 (ch. 2).

3.1.3 Azimuth alignment:

Play back the test tape No. 2. This is a full track pre-recorded tape with 10.000 c/s at $7\frac{1}{2}$ i.p.s. tape speed. Adjust the azimuth position of the playback head until maximum reading is obtained on both output meters.

3.1.4. Lateral alignment:

Check the lateral position of the playback head by pulling the pressure pad (59.5) away from the erase head when the test tape No. 2 is played back. The output level should not decrease more than 3 dB. Adjust the lateral position of the playback head, if necessary, by turning the head mounting plate. Re-adjust the azimuth position.

3.2 The record head.

3.2.1 Adjust the horizontal position of the bias head until the head is in center of the record head. Ref. fig. 1.

3.2.2 Adjust the height of the bias head until the tape runs freely in the groove in front of the bias head.

3.2.3 Height alignment:

The record head is set in a preliminary position where approx. 0.1 mm (.0025") of the lamination for the upper track is visible above the tape. The position of the record head can be inspected by using the iron powder method (Magna-See). Record all four tracks on the tape and dip the tape in the solution. The pattern on the tape will show if the position of the head is correct. Readjust if necessary.

3.2.4 Azimuth alignment:

Connect a signal generator to the HI-LEVEL inputs CH1 and CH2, and two V.T.V.M. to the CATHODE FOLLOWER outputs CH1 and CH2.

Make a stereo recording in B-test at $7\frac{1}{2}$ i.p.s. of a 15.000 c/s signal. Adjust the azimuth of the record head to max. reading on the output meters. The output level should now be approx. 100 mV with the playback volume controls to max., readjust the record gain controls until this is obtained and check the azimuth position of the record head.

3.2.5 Lateral alignment:

Check the lateral position of the record head by pulling the pressure pad (59.5) away from the erase head during the recording. The output level should not decrease more than 3 dB. Adjust the lateral position of the record head, if necessary, by turning the head mounting plate. Recheck the height and azimuth position of the head. Ref. para. 3.2.3 and 3.2.4.

3.3 The bias head.

3.3.1 Height alignment:

Connect two V.T.V.M. directly across the recording heads. Set the tape recorder to stereo recording at $7\frac{1}{2}$ i.p.s. and turn both playback volume controls down to 0.

Adjust the height of the bias head by the height adjustment screw (ref. fig. 1) until max. reading is obtained on both V.T.V.M. Check that the tape runs freely in the groove in front of the bias head and that there is sufficient clearance between the bias head and the mounting plate for the record head. The height position of the bias head is not critical, and if the clearance between the bias head and the mounting plate for the record head is insufficient, raise the bias head slightly.

3.3.2 Horizontal alignment:

Connect two V.T.V.M. to both CATHODE FOLLOWER outputs, and connect a signal generator to the HI-LEVEL inputs CH1 and CH2. Set the tape recorder to stereo recording at 7½ i.p.s. and turn both playback volume controls to max.

Record a 1000 c/s signal.

Untighten the fixing screw for horizontal adjustment (ref. fig. 1) and move the bias head from the extreme left position towards the recording head until max. reading is obtained on both V.T.V.M. The output level should now be approx. .5 V, readjust the record gain controls until this is obtained and check the horizontal position of the bias head. After one has assured that the horizontal position is correctly adjusted, tighten the adjustment screw making sure that the head is not being moved. This is eventually indicated by a loss of the output level.

A fine-adjustment of the bias current is obtained by the pot.meters R 609 (CH1) and R 612 (CH2). Adjust R 609 and R 612 until max. reading on the output meters are obtained.

3.4 The erase head.

3.4.1 Height adjustment:

The erase head is set in a preliminary position where approx. 0.25 mm (.01") of the ferrite core for the upper track of the erase head is visible above the tape. Insert the test tape No. 9 and record a 1000 c/s signal from the generator on ch. 2 at maximum recording level. Dip the tape in the Magna-See solution and check that the re-recorded track lies in center of the erased track. Make sure that the erase head does not erase any part of the adjacent tracks.

3.4.2 Azimuth alignment:

Align the azimuth position of the erase head by the azimuth adjustment screw. The erase head should be parallel with the mounting plate for the heads (15.4). The azimuth position of the erase head is not critical.

3.4.3 Lateral alignment:

Turn the head mounting plate for the erase head, until the front of the head is parallel to the pressure pad.

3.5 Model 62x.

All the alignments specified in chapters 3.1, 3.2, 3.3, and 3.4 are valid for model 62x with the exception of paragraph 3.1.2 which is superseded by 6.1.1 and paragraph 3.2.3 is superseded by 6.6.2.

4.0 Control and adjustment of playback amplifiers, with Tandberg test tapes.

4.1 Control of the playback amplifier:

Play back the test tape No. 3. This is a full track pre-recorded tape with the following frequencies: 250 -

10 000 - 5000 - 1900 - 100 - 50 - 250 c/s recorded at 7½ i.p.s. tape speed. The tape conforms with the N.A.B. standards. The output tolerance is ± 2 dB for all frequencies. The difference in level between the two channels should be less than 3 dB.

4.2 Adjustment of the playback amplifiers:

Play back the test tape No. 4 with the output volume controls to maximum. This is a full track pre-recorded tape with 400 c/s at 7½ i.p.s. tape speed. Adjust the potentiometers R233 (CH 1) and R234 (CH 2) until the reading on the output meters are 1.3 V.

5.0 Adjustment of the record current (A-B test) and the electronic beam indicators.

Make sure that all adjustments under paras 1.0, 2.0 and 3.0 are made before proceeding with these adjustments.

Connect a signal generator to both HI-LEVEL inputs and two V.T.V.M. to both CATHODE FOLLOWER outputs.

Record a 400 c/s signal in stereo A-test, with both playback volume controls to max. at 7½ i.p.s. Adjust the record levels by the record gain controls until the output levels are 1.5 V. Depress the push-buttons IV and V (stereo B-test) and adjust the record current by R 115 (CH1) and R 116 (CH2) until the readings on the output meters are 1.5 V.

Adjust R 137 (CH1) and R 138 (CH2) until the electronic beam indicators are closing. Release the push-buttons IV and V (stereo A-test) and check that the readings still are 1.5 V on the output meters.

6.0 Head alignment without Tandberg Test Tapes.

6.1 The playback head.

6.1.1 Height alignment:

The height of the playback head is aligned by the height adjustment screws. The upper edge of the tape shall run flush with the upper part of the airgap for channel 1.

6.1.2 Azimuth alignment:

Play back a standard azimuth alignment tape with a V.T.V.M. connected to each cathode follower output. Adjust the position of the playback head by the azimuth adjustment screw, until maximum reading is obtained on the output meters.

6.1.3 Lateral alignment:

Pull the pressure pad (59.5) away from the erase head when the standard azimuth alignment tape is being played back. The output level should not decrease more than 3 dB. Adjust the lateral position of the playback head, if necessary, by turning the head mounting plate.

6.2 The record head.

Follow the instructions given under para 3.2.

6.3 The bias head.

Follow the instructions given under para 3.3.

6.4 The erase head.

6.4.1 Height alignment:

The height of the erase head is aligned by the height adjustment screws. Approx. 0.25 mm (.01") of the

ferrite core for the upper track of the erase head should be visible above the tape.

6.4.2 Azimuth alignment:

Align the azimuth position of the erase head by the azimuth adjustment screw. The erase head should be parallel with the mounting plate for the heads (15.4). The azimuth position of the erase head is not critical.

6.4.3 Lateral alignment:

Turn the head mounting plate for the erase head, until the front of the head is parallel to the pressure pad.

6.5 Track control, model 64x.

6.5.1 The record head:

Record a 1000 c/s from a generator at maximum recording level in stereo A-test on track 1 and 3 (push-buttons I, II and III depressed) for approx. 5 seconds. Turn the tape around and make a similar recording on track 4 and 2. Cut the tape and dip it in a mixture of iron powder and alcohol (Magne-See) to make the recording visible. The spaces between the recorded tracks should be distributed equidistant across the tape. Readjust the height position, if necessary, and recheck the azimuth alignment.

6.5.2 The erase head:

Insert a full-track pre-recorded tape and record a 1000 c/s signal from a generator at maximum recording level in mono A-test on track 3 (push-buttons II and III depressed). Cut the tape and dip it in the Magne-See solution. Check that the re-recorded track is in the center of the erased area. Adjust the vertical pos. of the erase head if necessary.

6.5.3 The playback head:

Record a 1000 c/s signal on track 1 (CH1) and a 500 c/s signal on track 3 (CH2) at maximum recording levels. Turn the tape around and play back track 2 (push-buttons III and V depressed) at maximum volume. No signal should be heard. Raise the playback head if the 1000 c/s signal is heard. Lower the playback head if the 500 c/s signal is heard. Re-check the azimuth position.

6.6 Track control, model 62x.

6.6.1 The erase head:

The height of the erase head is aligned by the height adjustment screws. The tape shall run equidistant from the upper and the lower edge of the ferrite core.

6.6.2 The record head:

The height of the record head is aligned by the height adjustment screws. Record a 1000 c/s signal in stereo (push-buttons I, II and III depressed) at maximum recording level on a full-track pre-recorded tape. Dip the tape in the Magne-See solution and check that the tracks are distributed symmetrically across the tape, and that the recorded zone remains in the center of the erased zone. Readjust the erase and the record heads, if necessary.

6.6.3 The playback head:

The height of the playback head is aligned by the height adjustment screws. The tape shall run flush

with the upper edge of the lamination for channel 1. Readjust the azimuth in necessary.

7.0 Adjustments of the amplifiers, without Tandberg Test Tapes.

A V.T.V.M. is connected to each output terminal. The signal generator is connected to the high level inputs of both channels and tuned to 400 c/s.

The tape recorder is set up for stereo recording A-test (push-buttons I, II, and III depressed with the operating lever in normal forward drive position) at $7\frac{1}{2}$ i.p.s. tape speed. Insert a good quality recording tape.

Adjust the recording gain controls until the readings on the output meters are 1.5 V with the playback controls to maximum.

Replace the V.T.V.M. for channel 1 with a distortion meter and depress the push-button IV (B-test CH1). Adjust the recording current by R 115 until the reading shows 3 % distortion.

Replace the V.T.V.M. for channel 2 with the distortion meter and depress the push-button V (B-test CH2). Adjust the recorder current by R 116 until the reading shows 3 % distortion.

Adjust R 137 (CH1) and R 138 (CH2) until the electronic beam indicators are closing.

Connect a V.T.V.M. to each output terminal and proceed the recording as described above in stereo B-test with all push-buttons depressed.

Adjust the R 233 (CH1) and R 234 (CH2) until the reading on the output meters are 1.5 V. Make sure that the playback volume controls are set to max. Release the push-buttons IV and V (stereo A-test) and check that the reading on the output meters still are 1.5 V.

8.0 Control of total frequency response.

The tape recorder is set up for stereo recording B-test (all push-buttons depressed) at $7\frac{1}{2}$ i.p.s. tape speed, and with a good quality recording tape inserted. (Scotch 150 which should be run 5–10 times before use to have the tape surface polished.)

A V.T.V.M. is connected to each output terminal. The signal generator is connected to the HI-level inputs of both channels. Tune the generator to 400 c/s and set the output level from the generator 30 dB below maximum recording level. The readings on the output meters are the 0 dB reference points. Check the frequency response for all speeds according to the specification. Ref. fig. 7.

$7\frac{1}{2}$ i.p.s.: 20–25 000 c/s (± 2 dB 30–20 000 c/s)

$3\frac{3}{4}$ i.p.s.: 20–18 000 c/s (± 2 dB 30–15 000 c/s)

$1\frac{7}{8}$ i.p.s.: 30–12 000 c/s (± 2 dB 40– 9 000 c/s)

The difference in level between the two channels should be less than 3 dB at any frequency.

Increase the bias slightly if the treble response is too high. Adjust R 609 (CH1) and R 612 (CH2) for $7\frac{1}{2}$ i.p.s. and $3\frac{3}{4}$ i.p.s.

Adjust R 607 (CH1) and R 610 (CH2) for $7\frac{7}{8}$ i.p.s until correct frequency response is obtained.

8.1 Control of playback and record amplifiers.

If the frequency response does not stand up to the

for channel 1.

Output Tandberg

terminal. The
high level inputs

recording A-test
with the operat-
ion) at 7 1/2 i.p.s.
ding tape.

il the readings
the playback

with a distortion
/ (B-test CH1).
until the read-

h the distortion
/ (B-test CH2).
until the read-

ntil the electro-

rminal and pro-
ve in stereo B-

(CH2) until the
.5 V. Make sure
are set to max.

(stereo A-test)
output meters still

Response.

recording B-test
p.s. tape speed,
tape inserted.
5-10 times be-
lished.)

ut terminal. The
e HI-level inputs
r to 400 c/s and
enerator 30 dB
readings on the
e points. Check
ds according to

20 000 c/s)
15 000 c/s)
9 000 c/s)

e two channels
ency.

response is too
CH2) for 7 1/2 i.p.s.

or 7 1/8 i.p.s until
ed.

Amplifiers.

stand up to the

tolerances given above, one should check the play-
back and record amplifiers.

8.1.1 The playback amplifier:

Insert a 100 ohm resistor in series with the playback
head for the upper track (CH1) to ground (red wire).
Connect a signal generator across the resistor. De-
press the push-button IV (monaural playback CH1) and
set the operating lever to normal forward drive with
the playback volume control to maximum. The signal
generator is tuned to 400 c/s with an output level of
2 mV. The reading on the output meter is the 0 dB
reference point, at 7 1/2 i.p.s. tape speed. Check the
frequency response according to fig. 6.

Repeat the measurements for the lower track (CH2).
The output tolerance is ± 2 dB for all frequencies.
The difference in level between the two channels
should be maximum 3 dB at any frequency.

8.1.2 The record amplifier.

Insert a 1000 ohm resistor in series with the record
head for upper track (CH1) to ground (black wire).
Connect a V.T.V.M. across the resistor. The signal
generator is connected to the HI-level input of CH1.
Depress the push-button I (monaural recording CH1)
and set the operating lever to normal forward drive.
Tune the signal generator to 400 c/s and set the
output from the generator 30 dB below maximum
recording level. The reading on the output meter is
the 0 dB reference point. Check the frequency re-
sponse according to fig. 5.

Repeat the measurements for the lower track (CH2).
The output tolerance is ± 2 dB for all frequencies.
The difference in level between the two channels
should be less than 3 dB at any frequency.

9.0 Adjustment of the FM-multiplex filter.

Feed a 19 000 c/s signal to both FM-MX inputs and
depress the push-buttons I and II. Set the S-on-S
switch to A-B test and the playback volume controls
to maximum. The recording gain controls should be
set to maximum recording level. Connect a V.T.V.M.
to each cathode follower output. Adjust the core of
L4 (CH1) and L5 (CH2) for minimum reading on the
output meters.

10.0 Adjustment of the microswitches.

The bias is reduced in 1 7/8 i.p.s. tape speed to obtain
correct frequency response. The microswitches
(Ref. fig. 2 and 4) is introduced in the bias regulating
circuits and activate the potentiometers R 607 (CH1)
and R 610 (CH2) in 1 7/8 i.p.s. tape speed only. The
microswitches are located at the rear of the recorder,
ref. fig. 4.

Set the speed selector to 1 7/8 i.p.s. and loosen the
two screws holding the microswitch bracket. Move
the bracket slowly towards the activating arm until
the switches operate and tighten the two screws.
Check the adjustment by moving the speed selector
knob slowly from 1 7/8 to 3 3/4 i.p.s. and back. The
switches shall now operate properly.

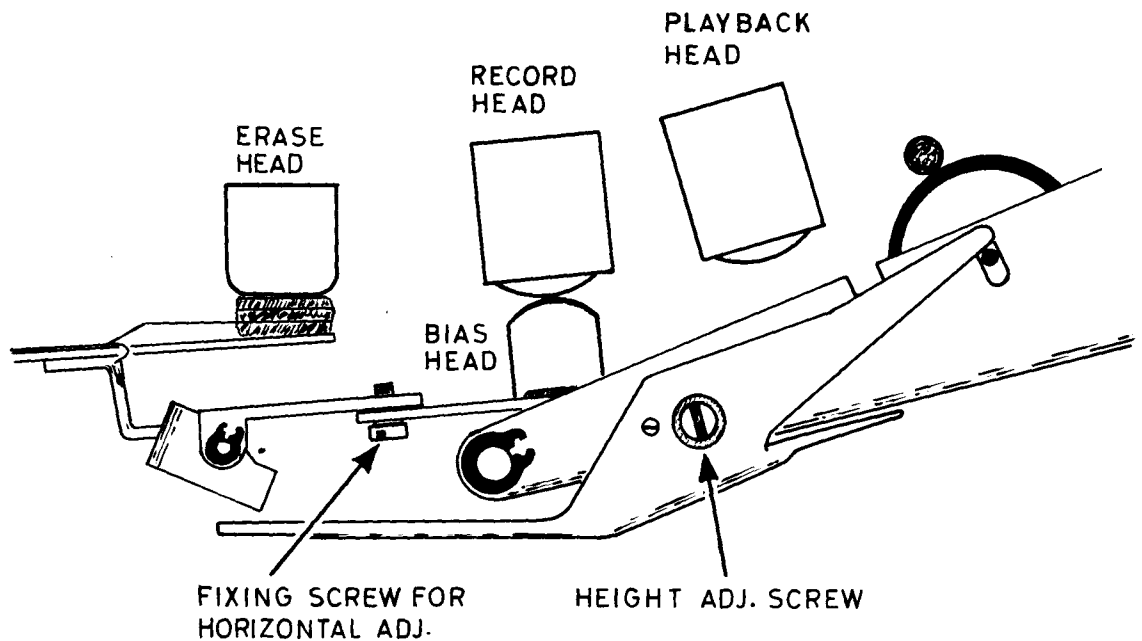
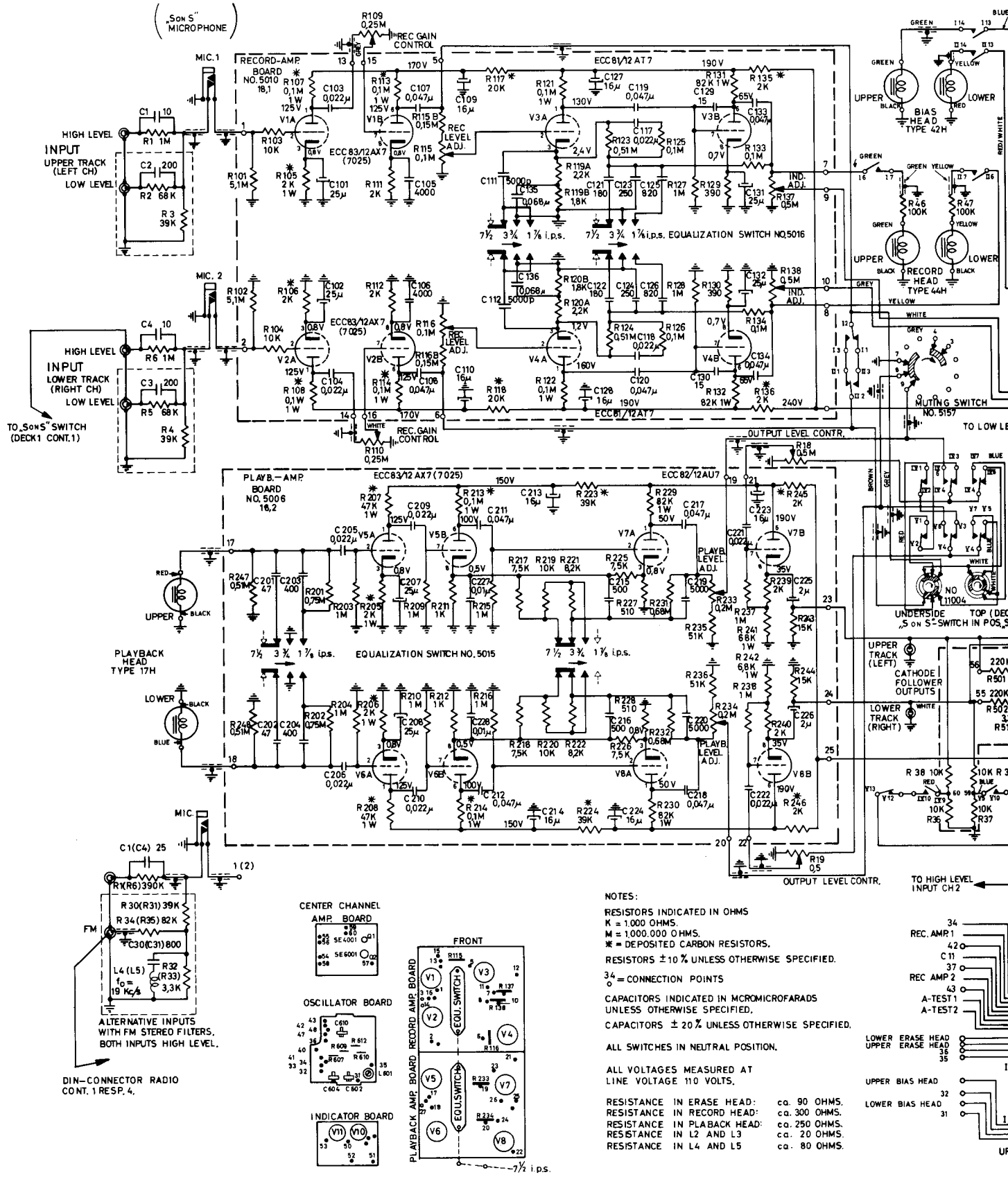
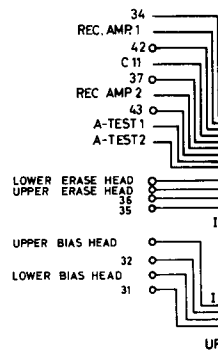

Fig. 1. The tape path, with location of the bias head.



NOTES:
 RESISTORS INDICATED IN OHMS
 K = 1,000 OHMS.
 M = 1,000,000 OHMS.
 * = DEPOSITED CARBON RESISTORS.
 RESISTORS ±10% UNLESS OTHERWISE SPECIFIED.
 34 = CONNECTION POINTS
 CAPACITORS INDICATED IN MICROMICROFARADS
 UNLESS OTHERWISE SPECIFIED.
 CAPACITORS ±20% UNLESS OTHERWISE SPECIFIED.
 ALL SWITCHES IN NEUTRAL POSITION.
 ALL VOLTAGES MEASURED AT
 LINE VOLTAGE 110 VOLTS.
 RESISTANCE IN ERASE HEAD: ca. 90 OHMS.
 RESISTANCE IN RECORD HEAD: ca. 300 OHMS.
 RESISTANCE IN PLAYBACK HEAD: ca. 250 OHMS.
 RESISTANCE IN L2 AND L3: ca. 20 OHMS.
 RESISTANCE IN L4 AND L5: ca. 80 OHMS.



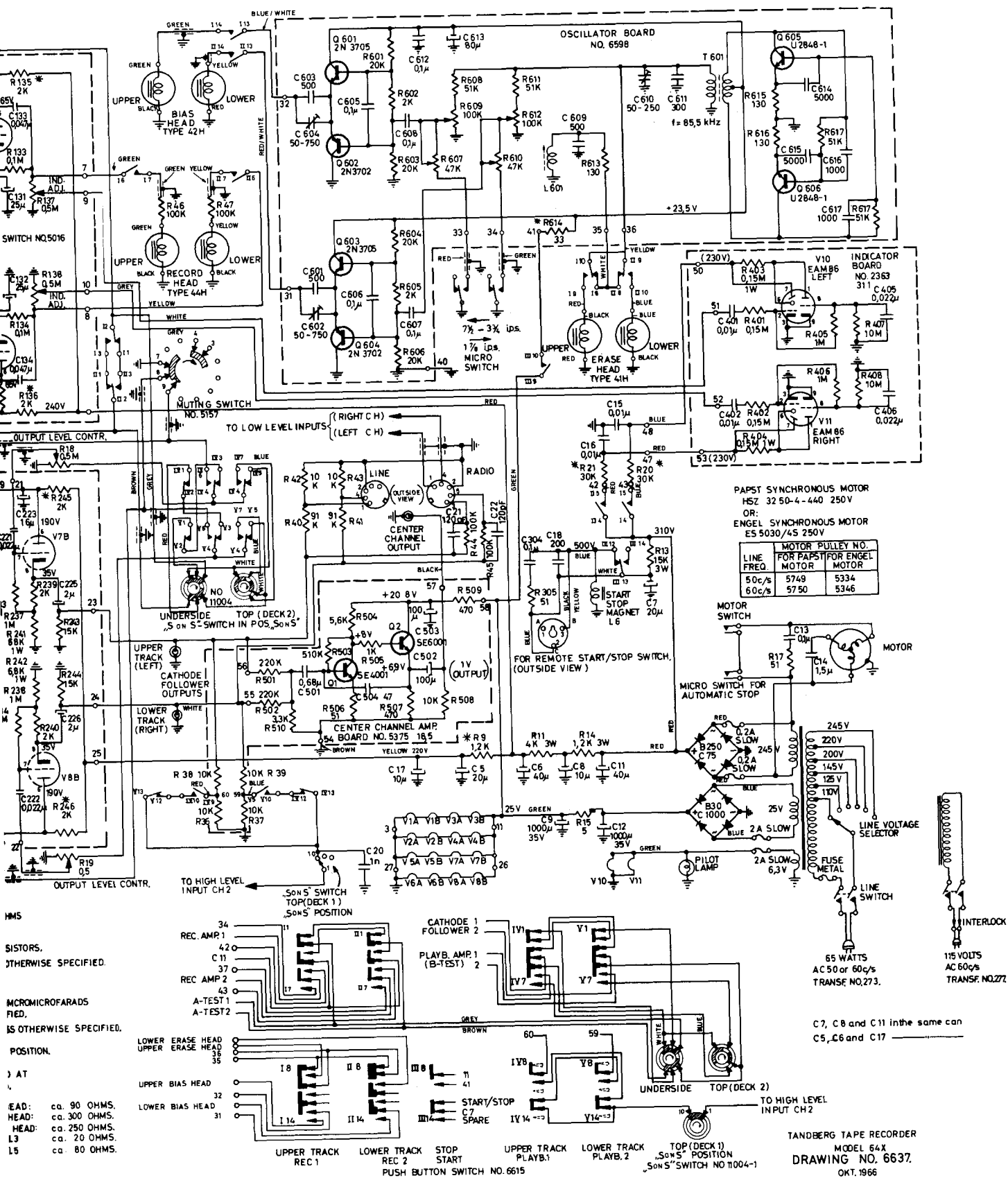

Fig. 2. Tandberg Tape Recorder Model 64x - 62x, Schematic.

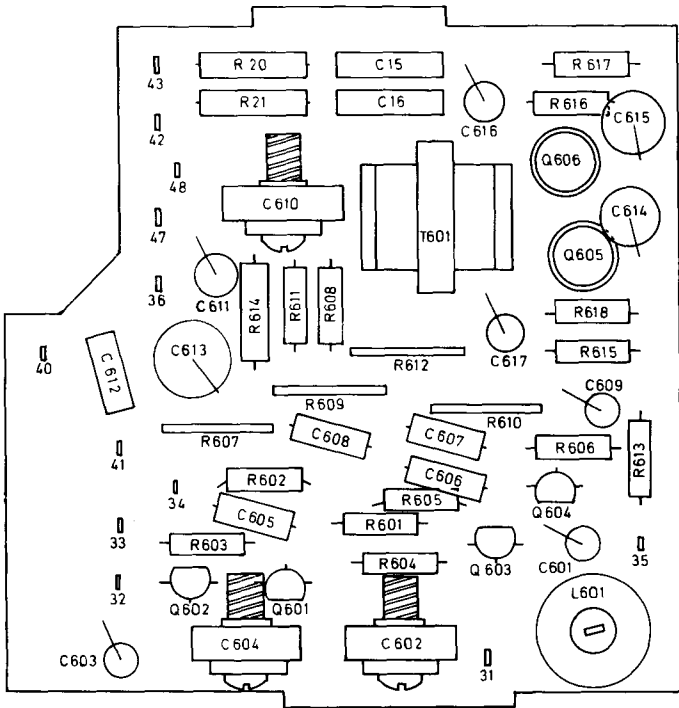

Fig. 3. The oscillator board, component lay out.

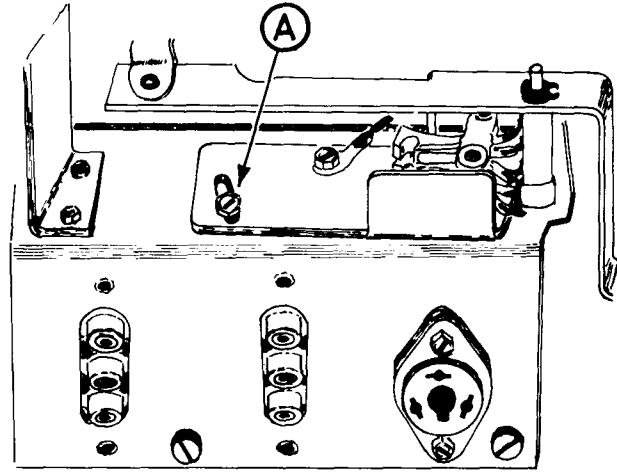

Fig. 4. Location of the microswitch for the bias circuit.

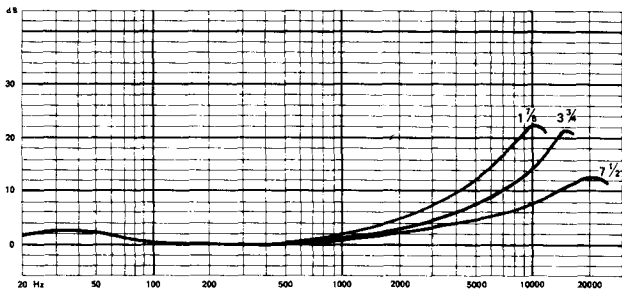

Fig. 5. The response curves for the record amplifiers.

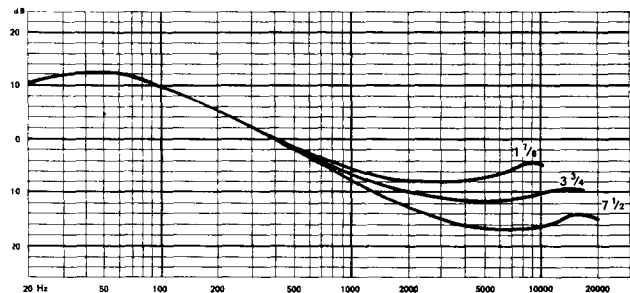

Fig. 6. The response curves for the playback amplifiers.

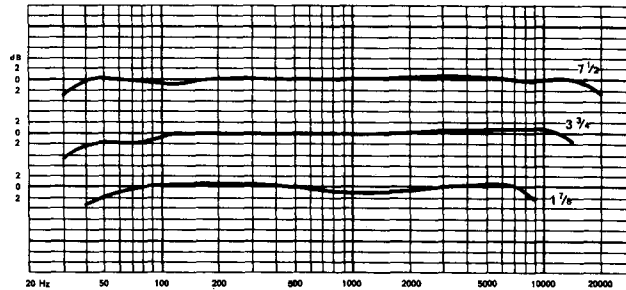

Fig. 7. Total frequency response curves.