

Tandberg
RADIO

Service manual

TANDBERG

**Tape recorder
model 6x**



Contents

1.0	Technical specification, Tandberg tape recorder models 64x and 62x	4	5.2.7	Monaural playback channel 1 or 2	33
2.0	The function of the controls	6	5.2.8	Stereo playback	33
3.0	The input and output terminals	7	5.2.9	Add a track	33
3.0.1	Models 64x and 62x, without 19 kHz FM-multiplex filter	7	5.2.10	Sound on sound	34
3.0.2	Model 64x and 62x, with 19 kHz FM-multiplex filter	7	5.2.11	Echo effects	34
3.0.3	The input and output terminals marked radio, line and center channel	7	5.3	Alignment	35
3.0.4	The microphone inputs	8	5.3.1	Demagnetizing	35
4.0	The mechanism, detailed description and adjustment instruction	8	5.3.2	The mounting plate for the heads	35
4.1	The operating lever	9	5.3.3	The adjustable tape guide	35
4.1.1	The motor switch	9	5.4	The playback head	35
4.1.2	The eccentric segment	10	5.4.1	Height alignment	35
4.1.3	The pressure wheel assembly	10	5.4.2	Azimuth alignment	35
4.1.4	The tape brake	12	5.4.3	Lateral alignment	35
4.1.5	The mechanical connection for the muting switch	12	5.5	Adjustment and control of playback amplifiers, with Tandberg test tapes	35
4.1.6	The trip bar	12	5.5.1	Adjustment of the playback amplifiers	35
4.2	The turntable assemblies	13	5.5.2	Control of the playback amplifier	35
4.2.1	The supply turntable assembly	13	5.6	Adjustment of the oscillator and bias head circuit	35
4.2.2	The tape tight tension	13	5.7	The record head	36
4.2.3	The brake for the supply turntable	13	5.7.1	Height alignment	36
4.2.4	The take-up turntable assembly	14	5.7.2	Azimuth alignment	36
4.2.5	Horizontal and vertical alignments of the turntables	15	5.7.3	Lateral alignment	36
4.3	Clutch alignments	15	5.8	The bias head	36
4.3.1	General	15	5.8.1	Height alignment	36
4.3.2	Fast rewind	16	5.8.2	Horizontal alignment	36
4.3.3	Fast wind	16	5.9	The erase head	36
4.3.4	Normal forward drive	17	5.9.1	Height alignment	36
4.3.5	Neutral	17	5.9.2	Azimuth alignment	36
4.3.6	Free	18	5.9.3	Lateral alignment	36
4.4	The motor pulley	18	5.9.4	Model 62x	36
4.4.1	Threading of the rubber drive belt	18	5.10	Adjustment of the record current (A-B test) and the electronic beam indicators	36
4.5	The speed transfer wheel	18	5.11	Head alignment without Tandberg test tapes	37
4.6	The lifting mechanism	19	5.11.1	The playback head	37
4.7	The flywheel with the capstan	20	5.11.2	Height alignment	37
4.8	The speed change mechanism	21	5.11.3	Azimuth alignment	37
4.9	The momentary start-stop feature	21	5.11.4	Lateral alignment	37
4.10	The pressure pad	22	5.12	The record head	37
4.11	The automatic end stop switch	22	5.13	The bias head	37
4.12	The revolution counter	22	5.14	The erase head	37
4.13	Assembling the top cover	22	5.14.1	Height alignment	37
5.0	The electronic circuits, detailed description and adjustment instruction	24	5.14.2	Azimuth alignment	37
5.1	The main electronic units, block diagram	24	5.14.3	Lateral alignment	37
5.1.1	The record pre-amplifier	24	5.15	Track control, model 64x	37
5.1.2	The FM-multiplex filter	25	5.15.1	The record head	37
5.1.3	The record amplifier	26	5.15.2	The erase head	38
5.1.4	The playback pre-amplifier	27	5.15.3	The playback head	38
5.1.5	The cathode follower	28	5.16	Track control, model 62x	38
5.1.6	The center channel amplifier	28	5.16.1	The erase head	38
5.1.7	The record level indicator circuit	29	5.16.2	The record head	38
5.1.8	The oscillator, bias and erase circuit	29	5.16.3	The playback head	38
5.1.9	The momentary start-stop circuit	30	5.17	Adjustment of the amplifiers, without Tandberg test tapes	38
5.1.10	The power supply	30	5.18	Control of total frequency response	38
5.2	The switching system, block diagram	31	5.19	Control of playback and record amplifiers	39
5.2.1	The push-button switch	32	5.19.1	The playback amplifier	39
5.2.2	The S-on-S switch	32	5.19.2	The record amplifier	39
5.2.3	Monaural recording on channel 1 or 2	32	5.20	Adjustment of the FM-multiplex filter	39
5.2.4	Mixing during monaural recording	32	5.21	Adjustment of the microswitches	39
5.2.5	Stereo recording	32	5.22	Vertical mounting of the models 64x and 62x	39
5.2.6	Mixing during stereo recording	33	5.23	Modification from model 64x to model 62x	40
			6.0	Parts list	40
			6.0.1	Mechanical parts	40
			6.0.2	Electrical parts	44
			6.1	Modification from 220 V 50 Hz to 110 V 60 Hz operation	53

6x

1.0 Technical specification, Tandberg tape recorder models 64x and 62x

- Power requirements: 110 – 125 – 145 – 200 – 245 Volts, 50 Hz.
U.S. models: 115 Volts, 60 Hz.
- Power consumption: 65 watts.
- Motor: Hysteresis synchronous motor.
- Tape speeds: $7\frac{1}{2}$, $3\frac{3}{4}$ and $1\frac{7}{8}$ inches per second.
- Speed accuracy: Relative accuracy, repeated playback: $\pm 0,2\%$ or $\pm 3,6$ seconds in 30 minutes.
Absolute speed tolerance: $\pm 0,5\%$.
- Playing time model 64x: Four-track recordings on 1800 ft of tape:
Tape speed $7\frac{1}{2}$ i.p.s.: Stereo 2 x 48 min., Mono 4 x 48 min.
Tape speed $3\frac{3}{4}$ i.p.s.: Stereo 2 x 96 min., Mono 4 x 96 min.
Tape speed $1\frac{7}{8}$ i.p.s.: Stereo 2 x 192 min., Mono 4 x 192 min.
- Playing time model 62x: Two-track recordings on 1800 ft of tape:
Tape speed $7\frac{1}{2}$ i.p.s.: Stereo 48 min., Mono 2 x 48 min.
Tape speed $3\frac{3}{4}$ i.p.s.: Stereo 96 min., Mono 2 x 96 min.
Tape speed $1\frac{7}{8}$ i.p.s.: Stereo 192 min., Mono 2 x 192 min.
- Fast wind and rewind: The fast wind or rewind time for 1800 feet of tape is approx. $2\frac{1}{2}$ minutes.
- Tape path: The tape moves from left to right.
- Recording tape: Maximum reel diameter is 7". Good quality recording tape is recommended.
- Automatic stop: The automatic stop operates during record or playback as well as during fast wind or rewind modes.
- Remote start-stop: A connector is provided for connection with a foot control switch.
- Heads, model 64x: 1 Quarter-track, two channel erase head.
1 Quarter-track, two channel record head. Air gap: 0,013 mm (0,0003").
1 Quarter-track, two channel playback head. Air gap: 0,002 mm (0,00008").
1 Quarter-track, two channel bias head.
- Heads, model 62x: 1 Half-track, two channel erase head.
1 Half-track, two channel record head. Air gap: 0,013 mm (0,0003").
1 Half-track, two channel playback head. Air gap: 0,002 mm (0,00008").
1 Half-track, two channel bias head.
- Frequency response: The model 64x has an extended frequency response. Typical frequency curves:
 $7\frac{1}{2}$ " per sec: 20–25.000 Hz (± 2 dB 40–18.000 Hz).
 $3\frac{3}{4}$ " per sec: 20–18.000 Hz (± 2 dB 40–14.000 Hz).
 $1\frac{7}{8}$ " per sec: 30–12.000 Hz (± 2 dB 40– 8.000 Hz).
In amplifier position: ± 2 dB 50–30.000 Hz.
- Distortion: The distortion from the record amplifiers at optimum recording level is less than 0,5%. The distortion from the tape recorded with a 400 Hz signal at optimum recording level is less than 3%, when played back. The distortion from the tape recorded with a 400 Hz signal at 10 dB below optimum recording level is less than 0,5%, when played back.

6x
Signal to noise ratio,
model 64x:

	weighted	unweighted
7 $\frac{1}{2}$ " per sec.:	60 dB.	52 dB at 3 % distortion (57 dB at 5 % distortion).
3 $\frac{3}{4}$ " per sec.:	57 dB.	
1 $\frac{7}{8}$ " per sec.:	54 dB.	

Signal to noise ratio,
model 62x:

7 $\frac{1}{2}$ " per sec.:	62 dB.	54 dB at 3 % distortion (59 dB at 5 % distortion).
3 $\frac{3}{4}$ " per sec.:	59 dB.	
1 $\frac{7}{8}$ " per sec.:	56 dB.	

Crosstalk:

The crosstalk rejection is better than 60 dB at 400 Hz.

Wow and flutter:

Better than 0,1 % RMS at 7 $\frac{1}{2}$ i.p.s. tape speed.
Better than 0,15 % RMS at 3 $\frac{3}{4}$ i.p.s. tape speed.
Better than 0,35 % RMS at 1 $\frac{7}{8}$ " i.p.s. tape speed.

Erase and bias frequency: The erase and bias frequency is 85,5 kHz \pm 2 kHz. The even harmonic distortion in the bias current is less than 0,5 %.

Recording level
indicators:

The electronic beam indicator range is 20 dB plus overload. The indicators are closing at optimum recording level (3 % distortion from the tape). The indicators are equipped with damping circuits.

Input impedance:

Microphone input CH1 and CH2:

Input impedance: 5 Mohm, maximum input voltage: 50 mV. Minimum input signal for optimum recording level at 1.000 Hz: 1,5 mV.

High level input CH1 and CH2:

Input impedance: 1 Mohm, maximum input voltage: 3 V. Minimum input signal for optimum recording level at 1.000 Hz: 50 mV.

Low level inputs CH1 and CH2:

Input impedance: 100 kohm, maximum input voltage: 200 mV. Minimum input signal for optimum recording level at 1.000 Hz: 4 mV.

FM-multiplex inputs:

Input impedance: 85 kohm, maximum input voltage: 2 V. Minimum input signal for optimum recording level at 1.000 Hz: 50 mV.

Note: The low level inputs CH1 and CH2 are replaced by FM-Multiplex inputs on tape recorders sold in certain territories.

Outputs:

An optimum recorded signal (3 % distortion from tape) will during playback give:

On CENTER CHANNEL output:

1 volt with 200 ohms load.

On CATHODE FOLLOWER outputs:

1,5 volts. Min. impedance 2 kohms.

On RADIO output:

750 mV with 11 kohms load.

The contacts 3 and 5 on the DIN connector is connected in parallel with the CATHODE FOLLOWER outputs CH1 and CH2.

On LINE output:

150 mV. Impedance 10 kohm.

Counter:

The 4 digit counter shows the number of revolutions of the take-up turntable.

Tubes and transistors:

4 ECC83 (12AX7), 2 ECC82 (12AU7), 2 ECC81 (12AT7), 2 EAM86, 1 SE6001, 1 SE4001, 2 V2848-1, 2 2N3705, 2 2N3702.

Rectifiers:

One high voltage selenium rectifier (B250 C75) and one low voltage selenium rectifier (B30 C1000).

Dimensions:

Teak cabinet 15 $\frac{3}{8}$ " long, 11 $\frac{13}{16}$ " wide and 6 $\frac{11}{16}$ " high.

Weight:

Instrument alone 23 lbs, with carrying case 25,5 lbs.

2.0 The function of the controls

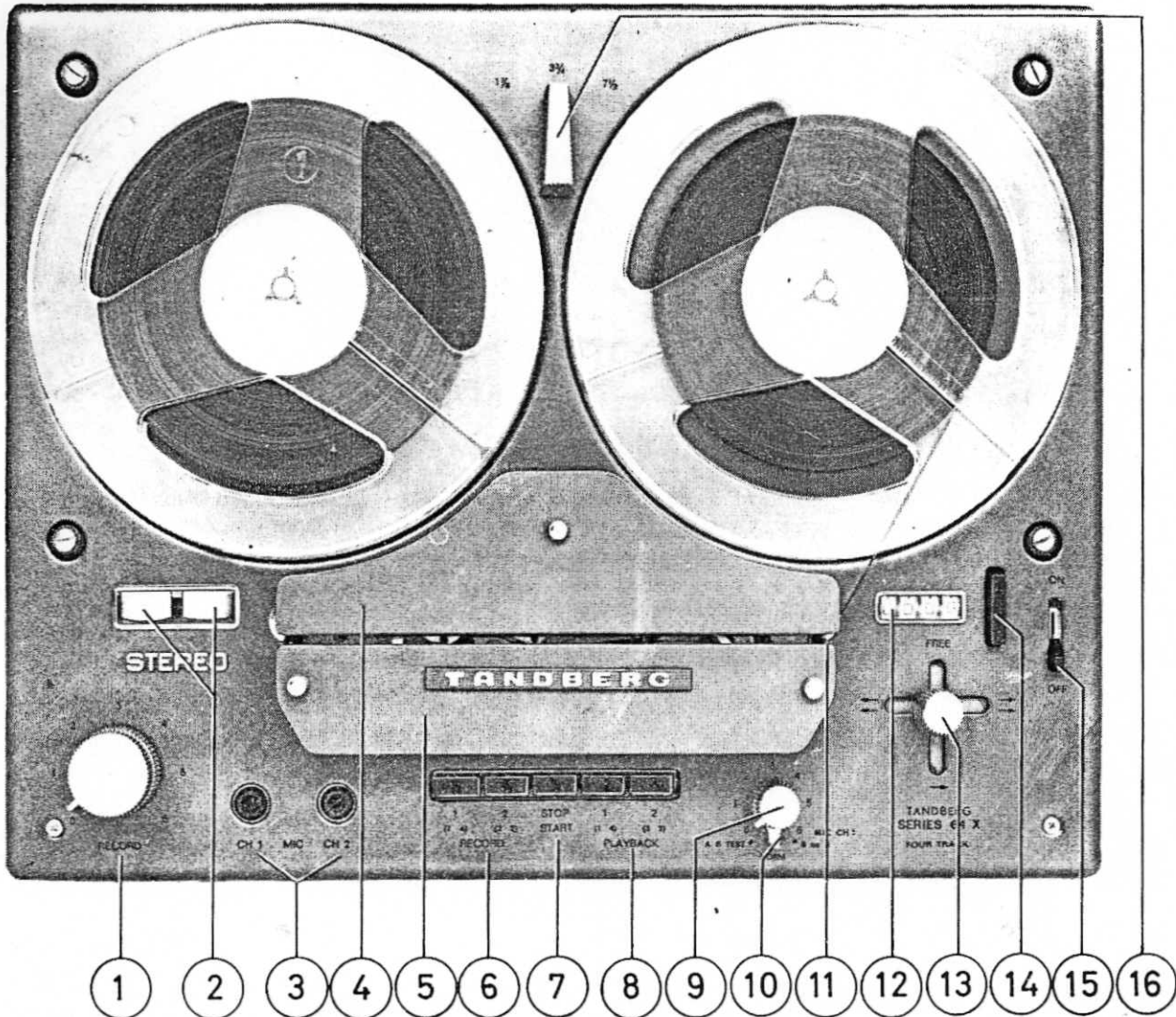

Fig. 1. The operating controls.

1. Record gain controls: Adjust the recording gain of both channels, separately or simultaneously.
Upper knob: Channel 1.
Lower knob: Channel 2.
2. Record level indicator: Indicates the recording level. Optimum recording level is obtained when the electronic beam indicators are nearly closed.
Left indicator: Channel 1.
Right indicator: Channel 2.
3. Microphone inputs: High impedance microphone inputs.
Mic. 1: Channel 1.
Mic. 2: Channel 2.
4. Rear trim cover: Remove the rear trim cover to clean or demagnetize the heads.
5. Front trim cover: Remove the front trim cover to clean or demagnetize the heads.
6. Record push-buttons 1 and 2: Activate the electronic circuits for recording. An interlock system is introduced between the record push-buttons and the operating lever to prevent undesired erasure.
Push-button 1: Channel 1.
Push-button 2: Channel 2.

- 6x
7. Start/stop push-button: Starts or stops the tape motion instantly when the operating lever is set to normal forward drive.
 8. Playback push-buttons 1 and 2: Activate the electronic circuits for playback.
Push-button 1: Channel 1.
Push-button 2: Channel 2.
 9. Playback volume controls: Provide individual adjustment of both outputs independent of the position of the push-buttons.
Upper knob: Channel 1.
Lower knob: Channel 2.
 10. Sound-on-sound switch: Has three positions: S-on-S – Normal – AB-test.
 11. Automatic end stop switch: Shuts off the motor when the tape runs out or if the tape breaks.
 12. Tape counter: Indicates the position of the tape.
 13. Operating lever: Activates the mechanism in the tape recorder for the different modes of operation.
 14. Re-set button: Re-sets the tape counter to zero.
 15. Power switch: Switches the mains on or off.
 16. Speed selector: Selects the desired tape speed.

3.0 The input and output terminals



Fig. 2.

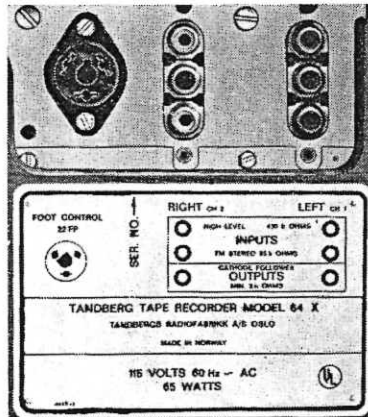

Fig. 3.

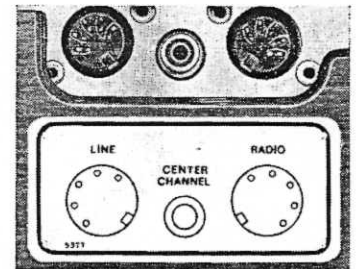

Fig. 4.

3.0.1 Model 64x and 62x without 19 kHz FM-multiplex filters

The input and output terminals together with the connector for the remote control are located at the rear of the tape recorder. Ref. fig. 2 and 4.

High level inputs:

Input impedance: 1 Mohm
Maximum input voltage: 3 V
Minimum input signal for optimum recording level at 1.000 Hz: 50 mV.

Low level inputs:

Input impedance: 100 kohms
Maximum input voltage: 200 mV
Minimum input signal for optimum recording level at 1.000 Hz: 4 mV.

Cathode follower outputs:

Minimum load impedance: 2 kohms.
Output level: 1,5 V.

3.0.2. Model 64x and 62x with 19 kHz FM-multiplex filters

The low level inputs CH1 and CH2 are replaced by FM-multiplex inputs on tape recorders sold in certain territories. Ref. fig. 3 and 4.

High level inputs:

Input impedance: 1 Mohm
Maximum input voltage: 3 V
Minimum input signal for optimum recording level at 1.000 Hz: 50 mV.

FM-multiplex inputs:

Input impedance: 85 kohms.
Maximum input voltage: 2 V.
Minimum input signal for optimum recording level at 1.000 Hz: 50 mV.

Cathode follower outputs:

Minimum load impedance: 2 kohms.
Output level: 1,5 V.

3.0.3 The input and output terminals marked RADIO, LINE and CENTER CHANNEL

The pins 1 and 4 on the DIN-contact RADIO are connected in parallel with the LOW LEVEL inputs CH1 and CH2, while the pins 3 and 5 on the same DIN contact are connected in parallel with the CATHODE FOLLOWER outputs CH1 and CH2.

The pins 1 and 4 on the DIN contact marked LINE are connected in parallel with the CATHODE FOLLOWER outputs CH1 and CH2. Ref. fig. 4.

The LINE outputs: Impedance: 10 kohms
Outputs level: 150 mV

The CENTER CHANNEL output: Minimum load impedance: 200 ohms
Output level: 1 V

The RADIO output: Impedance: 11 kohms
Output level: 750 mV

6x

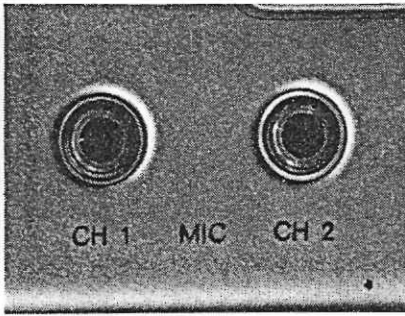

Fig. 5. The microphone inputs.

3.0.4 Microphone inputs

- The microphone jacks are located below the front trim cover on top of the recorder, ref. fig. 5.
- Microphone inputs:
 Input impedance: 5 Mohms
 Maximum input voltage: 50 mV
 Minimum input signal for optimum recording level at 1000 Hz: 1,5 mV.

4.0 The mechanism, detailed description and adjustment instruction

The main function of the mechanical system is to drive the turntables and the capstan in the different modes of tape motion. The mechanical function is activated by the operating lever.

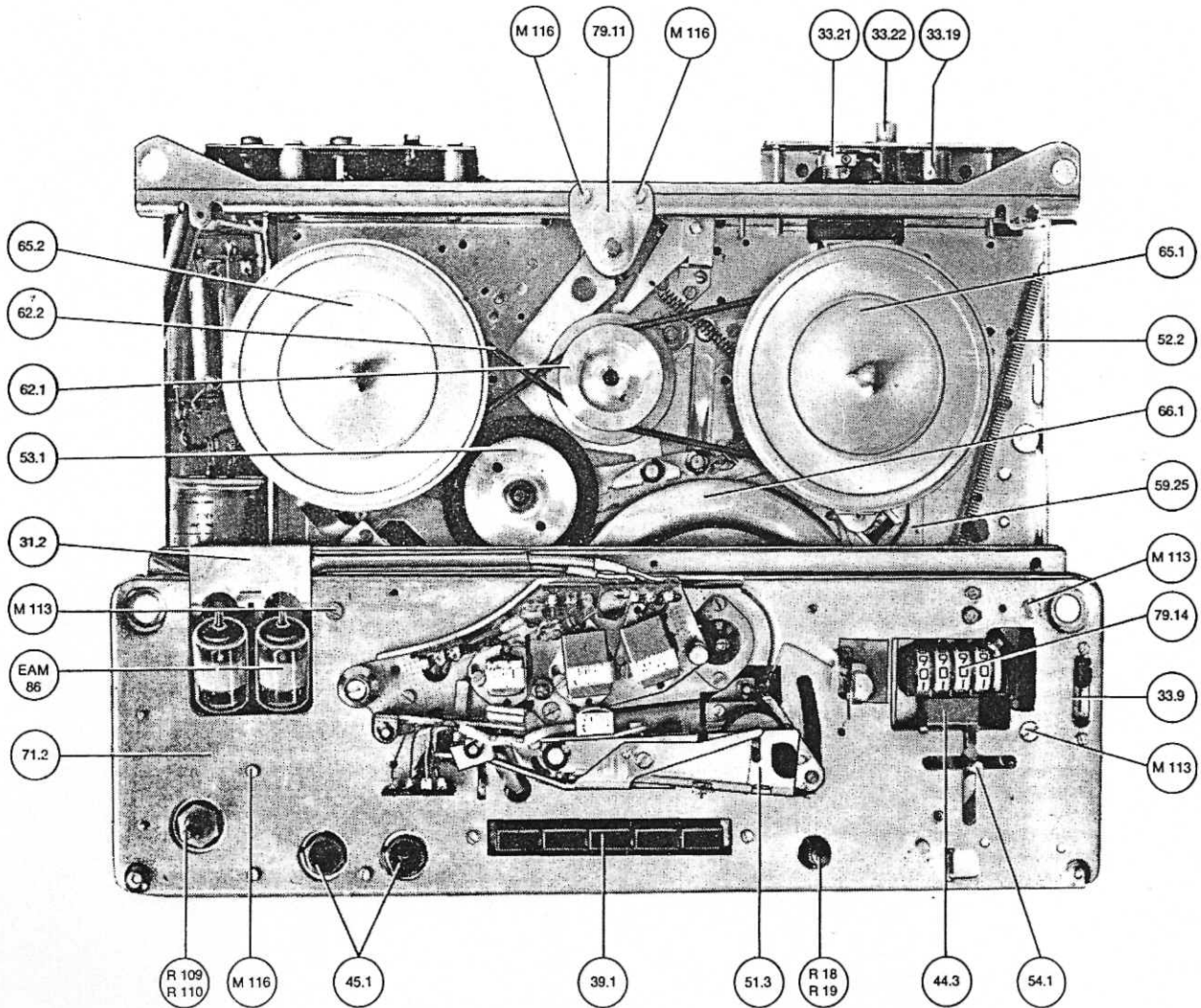

Fig. 6. Top view with top cover removed.

6x

4.1 THE OPERATING LEVER

The operating lever (54.1) has five positions and is located at the right front corner of the tape recorder: Normal forward drive, fast forward drive, fast rewind, free and neutral. (Ref. fig. 7).

The operating lever activates the following parts:

The motor switch (33.5): Connects the power to the motor (14.1) in normal forward drive, fast wind or fast rewind positions of the operating lever.

The eccentric segment (59.1): Guides the pressure wheel assembly (51.3), the lifting arm (59.25) and activates the arm (39.2) and the release lever (79.35).

The trip bar (52.1): Activates the clutches under the turntables (65.1, 65.2) and the brake (59.28) under the supply turntable (65.2).

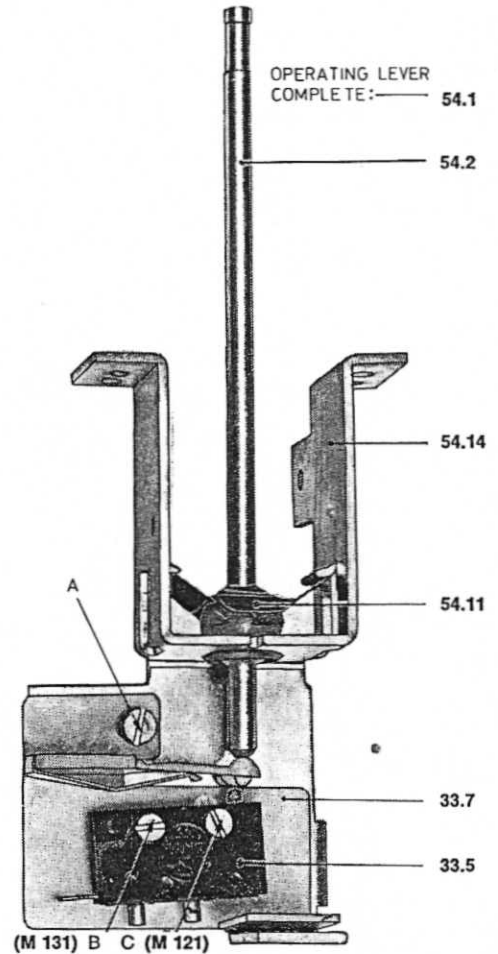

Fig. 7. The operating lever.

4.1.1 The motor switch

The microswitch (33.5) is located on the bracket for the operating lever (54.14) ref. fig. 7. The switch is connected in series with the motor current and is activated by the operating lever (54.1) to shut off the motor in neutral or free position.

Adjustments:

The operating point of the microswitch (33.5) should be set according to fig. 8. The motor should start when the operating lever (54.1) is moved from neutral to either normal forward, fast wind, or fast rewind position. Unscrew the three screws A, B, and C ref. fig. 7. Adjust the horizontal position of the delrin bracket (33.7) and the vertical position of the microswitch (33.5) obtaining proper positions for correct operating points.

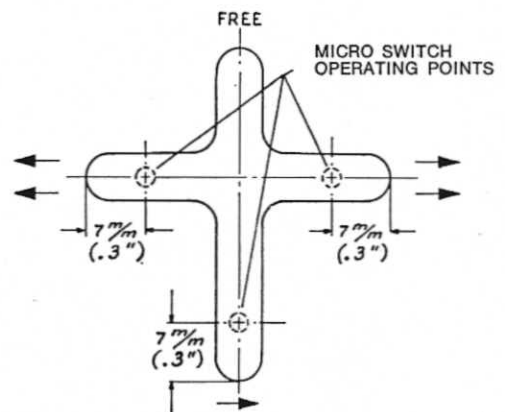

Fig. 8. Adjustment of operating points for the microswitch.

4.1.2 The eccentric segment

The eccentric segment (59.1) is located underneath the upper mounting plate (71.2) and is linked to the operating lever (54.1). Ref. fig. 9.

The eccentric segment (59.1) moves the pressure wheel (51.1) against the capstan (66.2) when the operating lever (54.1) is being set to normal forward drive.

The lifting arm (59.25) is linked to the eccentric segment (59.1) and releases the speed transfer wheel (53.1) from contacting the motor pulley (62.1) in all operating modes, except in the normal forward drive position.

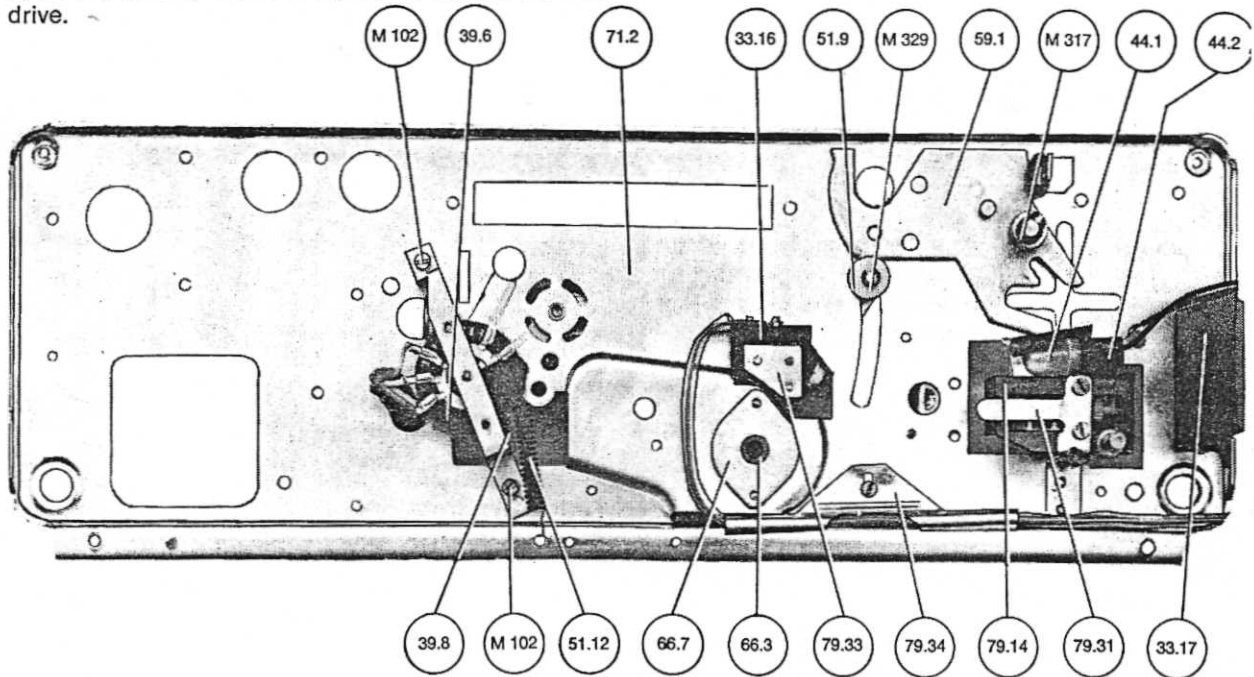

Fig. 9. The upper mounting plate, bottom view.

Adjustments:

Adjust the return motion of the pressure wheel assembly (51.3) by bending the lug ref. fig. 9 to as-

certain easy threading of the tape in the slot between the two trim covers (73.1, 73.2). The tape should not stick against the pressure wheel (51.1) during the threading.'

4.1.3 The pressure wheel Assembly

The pressure wheel assembly (51.3) is guided into operating position by the eccentric segment (59.1) when the operating lever (54.1) is moved to normal forward drive.

The pressure wheel (51.1) is mounted under balanced spring tension, with the pressure wheel shaft (51.2) running through two oblong slots in the pressure wheel bracket (51.14). The mounting will allow the pressure wheel (51.1) a horizontal springloaded play of approx. 6 mm (1/4"), on a line perpendicular to the front of the upper mounting plate (71.2). Ref. fig. 10 and fig. 70.

Adjustments:

The balanced spring tension of the pressure wheel (51.1) is adjusted to obtain uniform pressure of the pressure wheel against the capstan. Loosen screw E, (M120), and turn the spring equalization latch (51.7) clockwise or counter clockwise until the tape runs smoothly by the pressure wheel (51.1) in normal forward drive. Make sure that no air-pockets are formed between the tape and the pressure wheel (51.1), and that the tape is completely covered by the rubber surface of the pressure wheel. Ref. fig. 10 and 11.

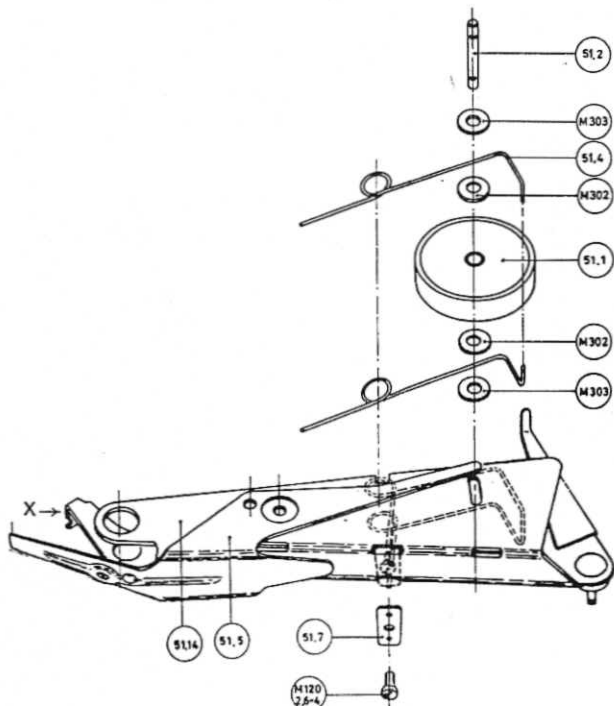

Fig. 10. The pressure wheel assembly, exploded view.

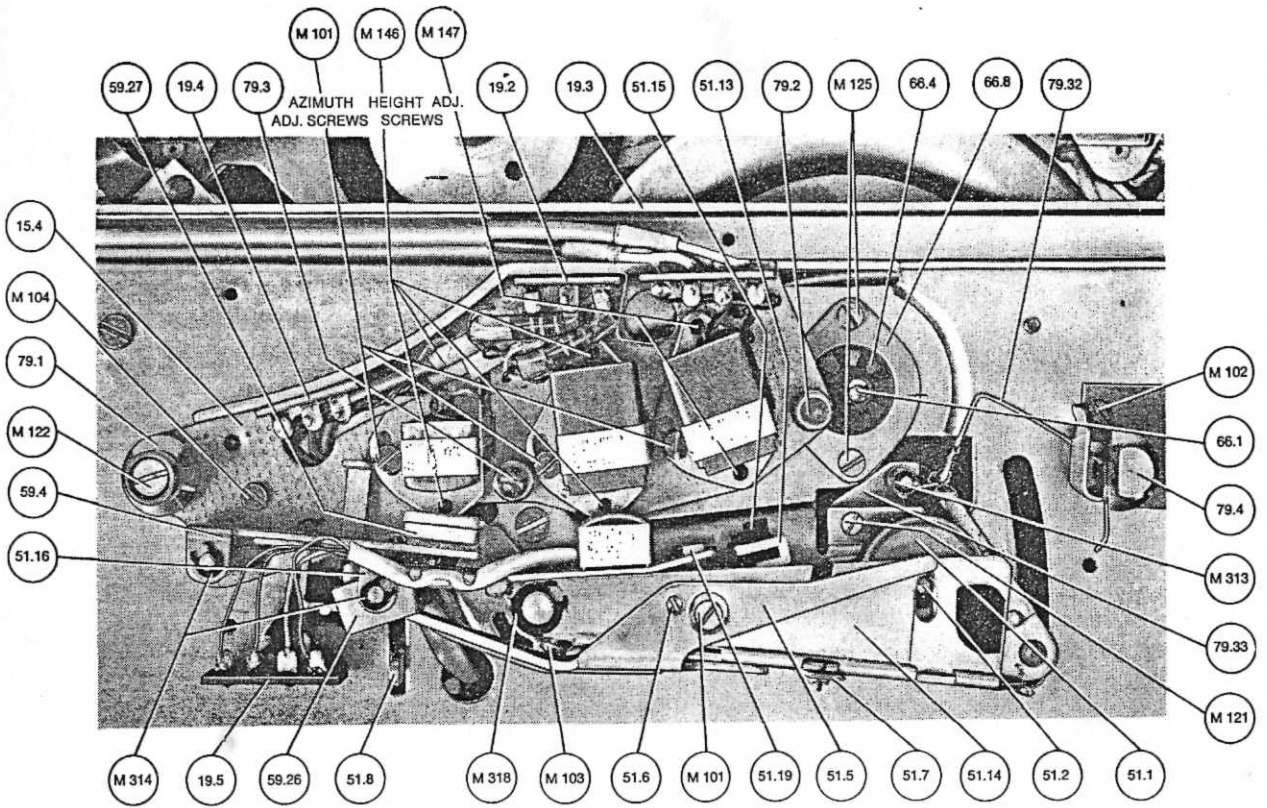

Fig. 11. Mounting plate for the heads with the pressure wheel assembly.

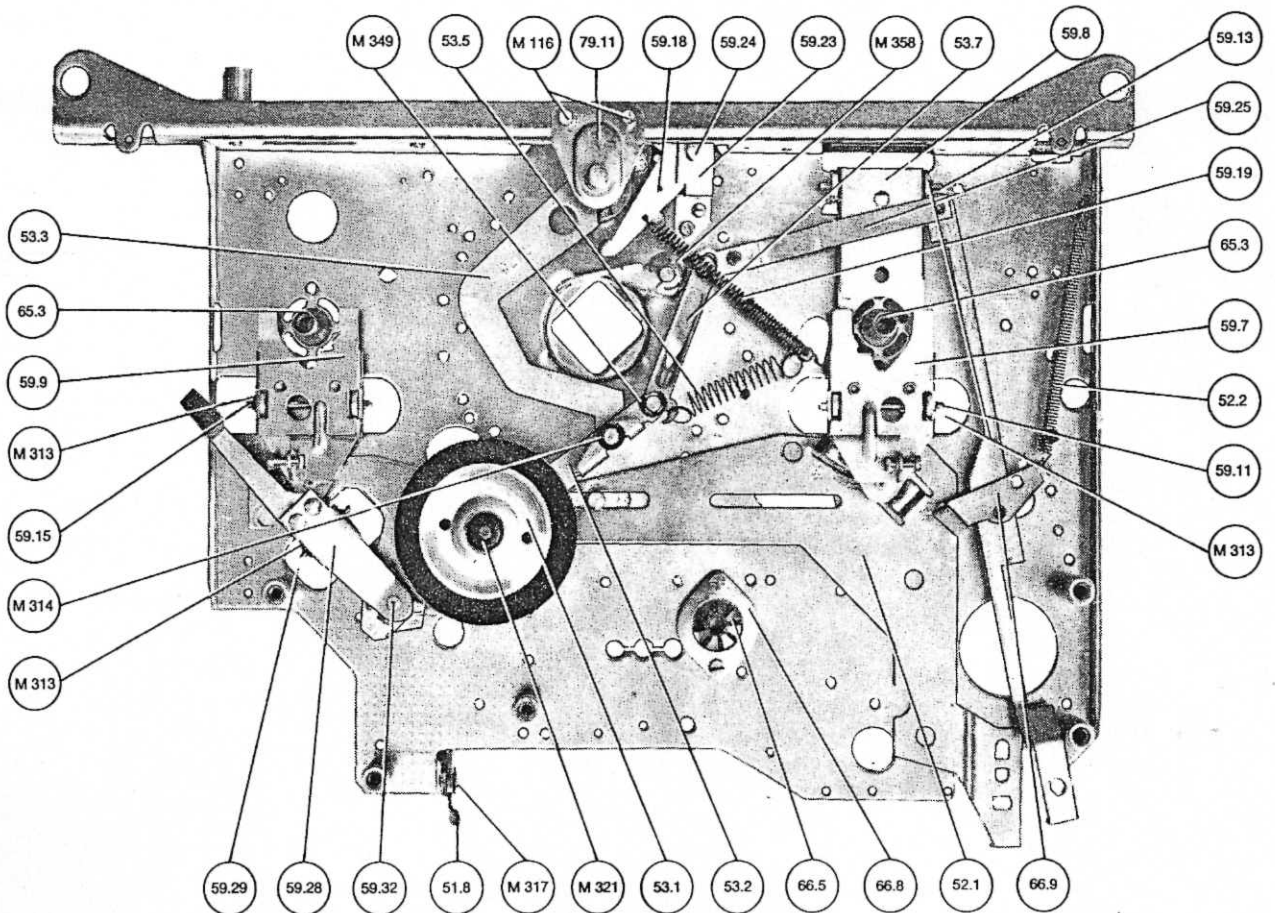

Fig. 12. The lower mounting plate, with the turntables removed.

4.1.4 The tape brake

The tape brake (51.13) is located inside the pressure wheel assembly (51.3) and is activated by the pressure wheel lever (51.5). Ref. fig. 11 and 70. The tape brake (51.13) prevents the tape from creeping when the operating lever (54.1) is in normal forward drive position with the start-stop push-button in stop position (released).

From serial no approx. 240 65 76 the tape brake has been modified. The parts 51.13 and 51.15 are deleted. When the brake lever is operated, the pressure wheel is pressed against a brake block (part 248752) which is located inside the pressure wheel bracket. The brake block is mounted on a spring (part 249966) by means of a screw through the bracket. If the modification is to be done on an earlier model, the mounting hole must be filed to a square shape.

Adjustments:

Set the operating lever (54.1) to normal forward drive and the start-stop push-button to the stop position (released), with tape inserted. The tape brake (51.13) should prevent the tape from creeping when the pressure pad arm (59.4) is pulled away from the erase head.

Start the mechanism by depressing the start-stop push-button. The tape brake (51.13) should be completely disengaged. Adjust the screw F (ref. fig. 11 and 70) until the spacing between the tape brake (51.13) and the playback head is approx. 2 mm (0,08").

4.1.5 The mechanical connection for the muting switch

The muting switch (39.6) is located above the start-stop magnet (31.1) between the upper and the lower mounting plates (71.2, 71.1). Ref. fig. 9.

The muting switch (39.6) shortcircuits both playback pre-amplifier outputs to ground in all positions of the operating lever except normal forward drive. The switch is introduced to prevent noise from the playback amplifiers. The pressure wheel assembly (51.3) activates the muting switch (89.6) by the lug X. Ref. fig. 10. The lug enters through an oblong slot in the upper mounting plate (71.2) in front of the erase head.

4.1.6 The trip bar

The trip bar (52.1) is located at the top of the lower mounting plate (71.1), and linked to the operating lever (54.1). Ref. fig. 12. The trip bar activates the clutches underneath both turntables (65.1, 65.2) and the brake underneath the supply turntable (59.28) by a sliding motion. The vertical position of the two clutches and the brake are determined by the raised areas of the trip bar (52.1).

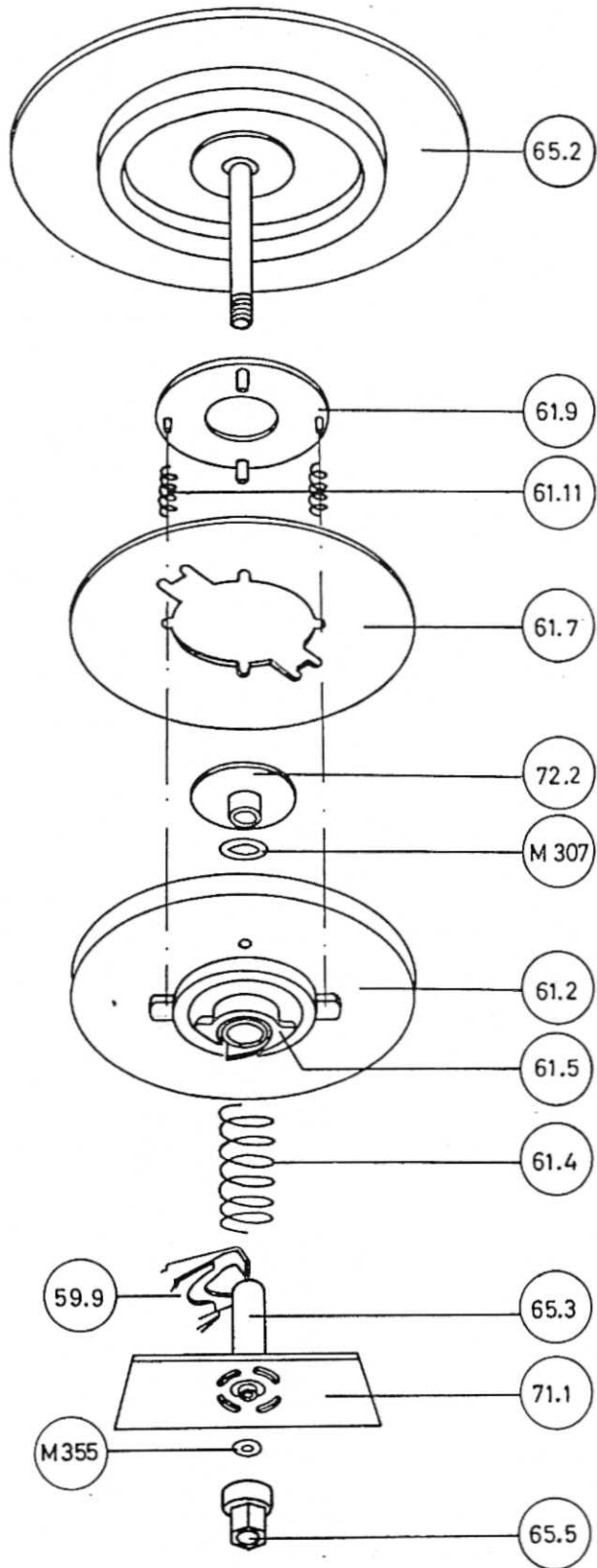

Fig. 13. The supply turntable assembly, exploded view.

4.2 THE TURNTABLE ASSEMBLIES

The design of the turntable assemblies is shown in fig. 13 and 16. The turntable assemblies are built up around the two housings for the turntable bearings (65.3). The housings for the turntable bearings (65.3) are riveted to the lower mounting plate (71.1).

4.2.1 The supply turntable assembly

The supply turntable assembly is put together by first inserting the helical compression spring (61.4) and the pulley disc (61.2) over the housing (65.3). Make sure the compression spring (61.4) fits into the cylindrical groove in the cartridge (61.5). The two delrin lugs and the tongue on the cartridge (61.5) should lie on a line perpendicular to the front edge of the upper mounting plate (71.2), with the delrin tongue pointing towards the front. Press down the pulley disc (61.2) until the delrin lugs on the cartridge (61.5) have passed through the notch in the clutch lever (59.9). Turn the cartridge (65.5) 90° counter clockwise. Make sure that the two delrin lugs have been locked in position by the claws on the clutch lever (59.9), and that the tongue on the cartridge (61.5) fits into the groove in the clutch lever (59.9). Ref. fig. 13 and 14.

Insert the flange for the turntable housing (72.2) by pressing it into the upper end of the housing (65.3). Place the mylar sheet (61.7) on the top of the pulley disc (61.2) and insert the two springs (61.11) in the wells. Attach the tape tight disc (61.9) with the short pins inside the two springs (61.11) and insert the turntable (65.2). Ref. fig. 15.

Move the operating lever (54.1) to the fast wind position. This will allow the supply turntable (65.2) to rest on the flange (72.2). Insert one teflon washer (M348) and a suitable number of turbax washers (M355) on the turntable shaft, under the lower mounting plate (71.1), before the delrin nut (65.5) is attached. Ascertain an axial play in the turntable shaft of approx. 0,1 mm (0,04").

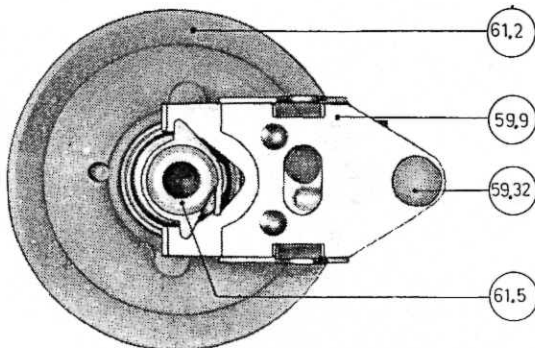

Fig. 14. The supply pulley disc with clutch lever.

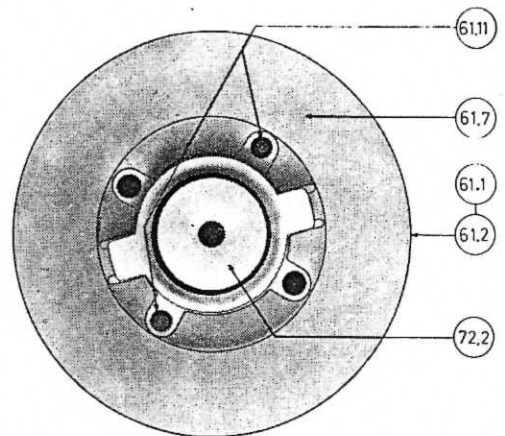

Fig. 15. The supply pulley disc with the mylar sheet.

4.2.2 The tape tight tension

A slight permanent clockwise torque of the supply turntable (65.2) has been introduced to prevent a tape loop from being formed between the supply turntable (65.2) and the trim covers (73.1, 73.2) when the operating lever is in normal forward drive, and the start-stop push-button is operated. The tape tight disc (61.9) is a spring loaded friction disc that presses against a round piece of green felt underneath the supply turntable (65.2). Ref. fig. 13.

Adjustments:

The adjustment is made by stretching or cutting the two springs (61.11). The torque should be just sufficient to take up the loop formed when the operating lever is in normal forward drive, and the tape recorder stopped by releasing the start-stop push-button. The tape recorder should be loaded with a full 7" tape reel on the supply turntable (65.3).

Note: Do not increase this torque unnecessarily, as excessive torque might introduce wow and flutter.

4.2.3 The brake for the supply turntable

The brake (59.28) is located under the supply turntable (65.2) and is introduced to prevent eventual creeping of the tape when the operating lever is moved from normal forward drive to neutral position. The brake (59.28) also prevents loops from being formed after fast wind. Ref. fig. 12.

Adjustments:

The braking action should be smooth, without any tendency of backlash at the take-up turntable (65.1), when the operating lever (54.1), is moved from fast rewind to neutral position. Decrease the braking action by bending down the bronze lever on the brake (59.28) if backlash occurs at the tape-up turntable. Make sure that the brake is engaged in neutral position.

Note: The brake should be operative only on tape recorders equipped with Papst motors.

6x

4.2.4 The take-up turntable assembly

The take-up turntable assembly is put together by first inserting the helical compression spring (61.3) and the pulley disc (61.1) over the housing (65.3). Make sure the compression spring (61.3) fits into the cylindrical groove in the cartridge (61.5). The two delrin lugs and the tongue on the cartridge (61.5) should lie on a line perpendicular to the front edge of the upper mounting plate (71.2), with the delrin tongue pointing at the rear edge of the lower mounting plate (71.1). Press down the pulley disc (61.1) until the delrin lugs on the cartridge (61.5) have passed through the notch in the upper clutch lever (59.7). Press the lower clutch lever (59.8) all the way down by using a screw driver. The space between the two clutch levers (59.7, 59.8) will now be approx. 6 mm (1/4"). Turn the cartridge (61.5) 90° clockwise, and make sure that the two delrin lugs have been locked in position by the claws on the lower clutch lever (59.8). Ref. fig. 16 and 17.

Insert the flange for the turntable housing (72.1) by pressing it into the upper end of the housing (65.3). Place the mylar sheet (61.6) on the top of the friction disc (61.1) and insert the turntable (65.1). Move the operating lever (54.1) to the fast rewind position. This will allow the take-up turntable (65.1) to rest on the flange (72.1). Insert one teflon washer (M355) on the turntable shaft under the lower mounting plate (71.1) before the pulley (69.1) is attached. Ascertain an axial play of the turntable shaft of approx. 0,1 mm (0,04").

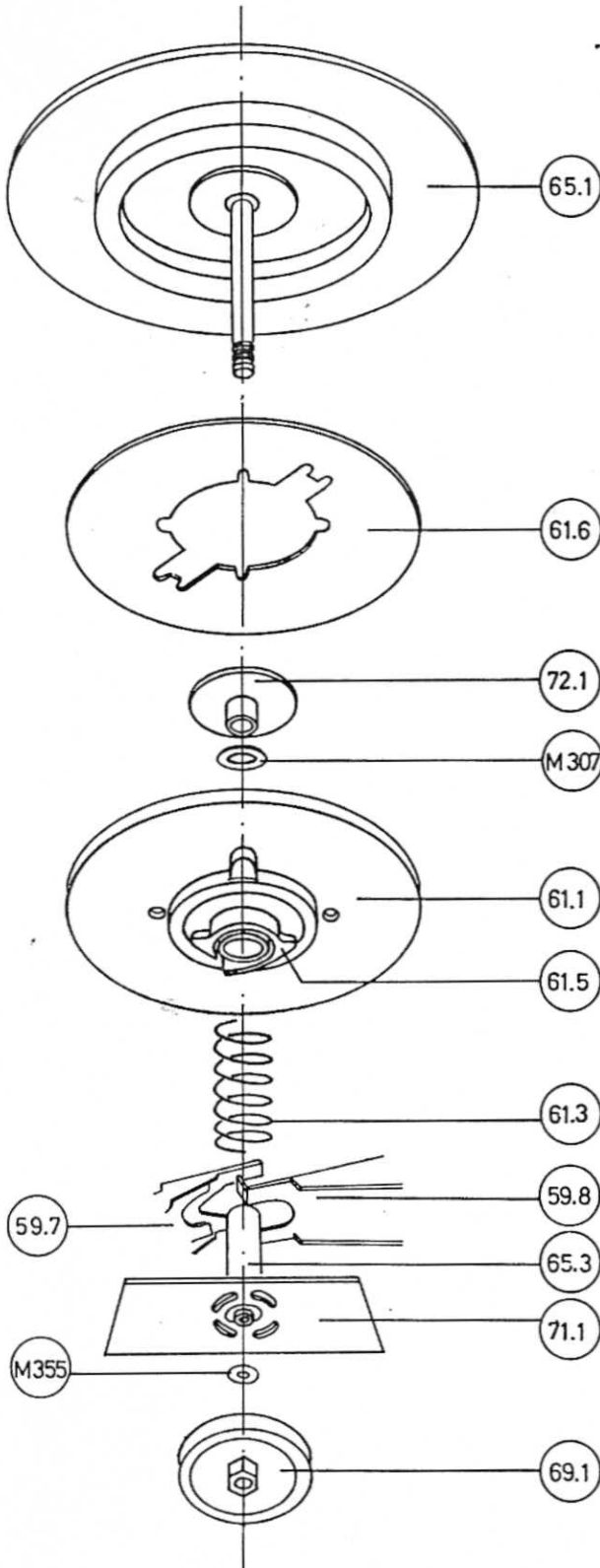

Fig. 16. The take-up turntable assembly, exploded view.

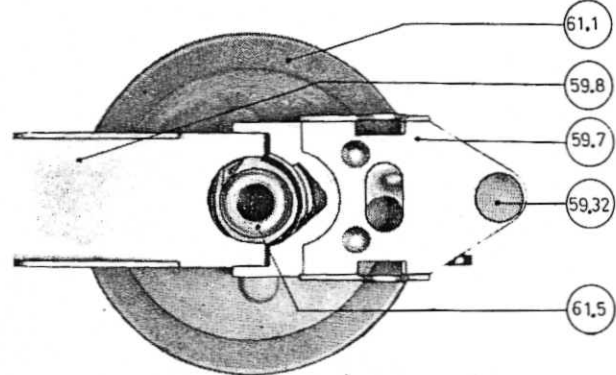

Fig. 17. The take-up pulley disc with clutch levers.

4.2.5 Horizontal and vertical alignments of the turntables

Use the special tools 1, 2 and 3 for these alignments. Ref. fig. 71.

Horizontal alignments

The horizontal position of the two turntables (65.1, 65.2) parallel to the lower mounting plate (71.1) is checked by placing the special tool No. 1 across both turntables as shown in fig. 18). There should be no spacing between the ruler (tool No. 1) and the turntables.

Necessary adjustments are made by bending the turntable housing in correct position. Use the special tool No. 3 as shown in fig. 19.

The horizontal position of both turntable (65.1, 65.2) parallel to a line perpendicular to the front edge of the upper mounting plate (71.2) is checked by using the special tool No. 2.

The edge of the tool No. 2 should run exactly into the tape groove in the tape guide (79.1, 79.2), when the operating lever (54.1) is in the neutral position. Ref. fig. 20.

Necessary adjustments are made by bending the turntable housing (65.3) in correct position. Use special tool No. 3, as shown in fig. 19.

Vertical alignments

The horizontal position of the turntables must be set before the vertical alignment is made.

The vertical position of the turntables is checked with the tape threaded on the recorder. The tape should not touch the edges of the plastic reels in any mode of operation.

The turntables are raised or lowered, if necessary, by adding or subtracting turbax washers (M306-7) between the flange for the turntable housing (72.1, 72.2) and the turntable housing (65.3). Ref. fig. 13 and 16. A final check of the horizontal position of the turntables should be made.

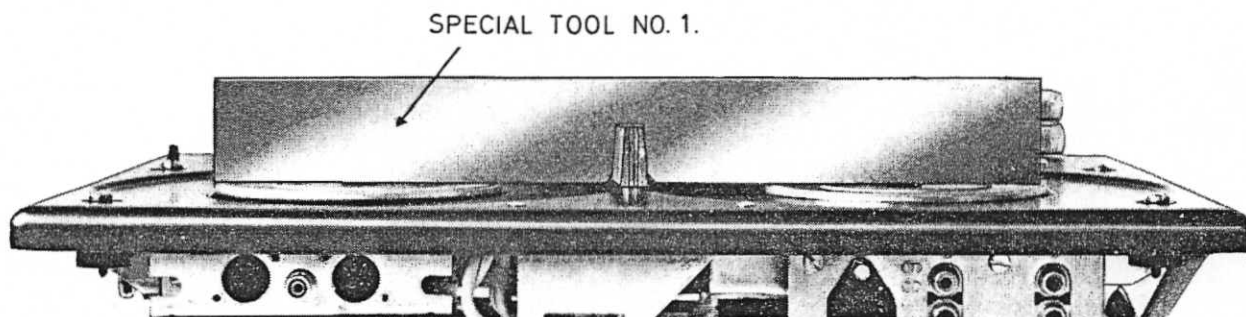

Fig. 18. Control of the horizontal position of the turntables with tool No. 1.

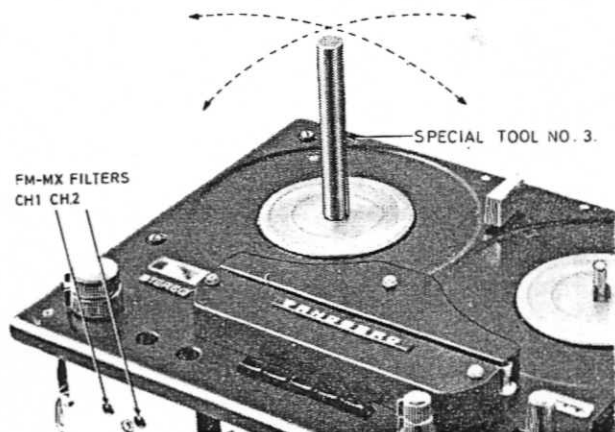

Fig. 19. Alignment of the horizontal position of the turntables with tool No. 3.

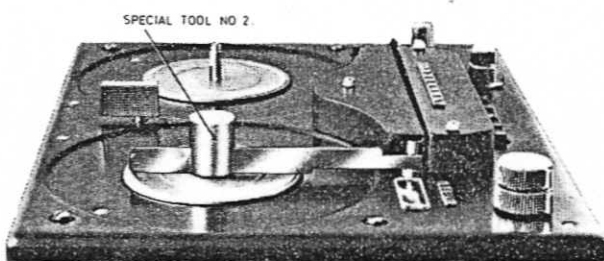

Fig. 20. Control of the horizontal position of the turntables with tool No. 2.

4.3 CLUTCH ALIGNMENTS

4.3.1 General

The motor will always run and drive both pulley discs (61.1, 61.2) when the operating lever (54.1) is set to either normal forward drive, fast wind, or fast rewind position. The two pulley discs will run in the opposite directions caused by the cross threading of the rubber drive belt (62.2). Ref. fig. 6.

The torque of the turntables (65.1, 65.2) is obtained by the friction between the pulley discs (61.1, 61.2) and the feltrings glued to the turntables (65.1, 65.2). The friction between the pulley discs and the turntables is determined by the position of the clutches mounted under each pulley disc. The clutches are operated by the trip bar (52.1), which is connected to the operating lever (54.1).

4.3.2 Fast rewind

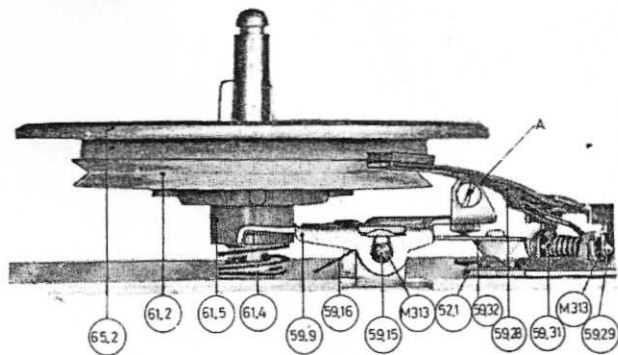

Fig. 21.

The supply turntable

The supply turntable (65.2) has maximum obtainable friction with the pulley disc (61.2) in this position.

The pulley disc (61.2) is pressed against the turntable (65.2) by the entire tension of the compression spring (61.4).

The trip bar (52.1) has moved, and the delrin button (59.32) on the clutch lever (59.9) is at the lower position. The two delrin lugs on the cartridge (61.5) and the clutch lever (59.9) are disengaged.

Adjustments:

Adjust the height of the clutch lever (59.9) by the screw (A) until the clearance between the clutch lever (59.9) and the delrin lugs on the cartridge (61.5) is approx. 0,5–1 mm (0,02"–0,04"). The torque of the supply turntable (65.2) should be min. 75 g (2³/₄ OZ) acting on an arm of 8 cm (3¹/₂"). Recheck all other positions of the operating lever and finally seal the adjustment screw.

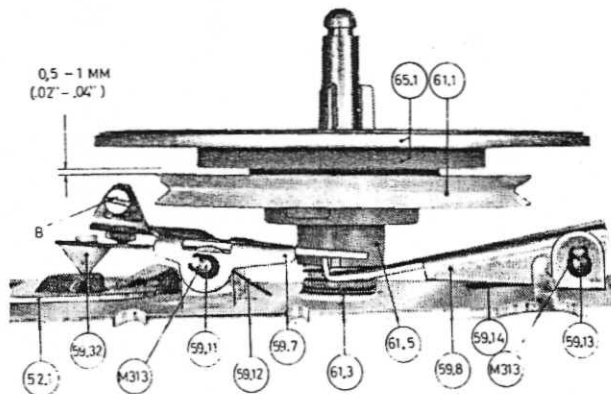

Fig. 22.

The take-up turntable

The take-up turntable (65.1) is completely disengaged from the pulley disc (61.1) and is free-running in this position. The trip bar (52.1) has moved, and the delrin button (59.32) on the upper clutch lever (59.7) is at the highest position, pressing down both the lower clutch lever (59.8) and the two delrin lugs on the cartridge (61.5).

Adjustments:

Adjust the height of the upper clutch lever (59.7) by the screw (B) until the clearance between the pulley disc (61.1) and the feltring on the turntable (65.1) is approx. 0,5–1 mm (0,02"–0,04"). Recheck all other positions of the operating lever and finally seal the adjustment screw.

4.3.3 Fast wind

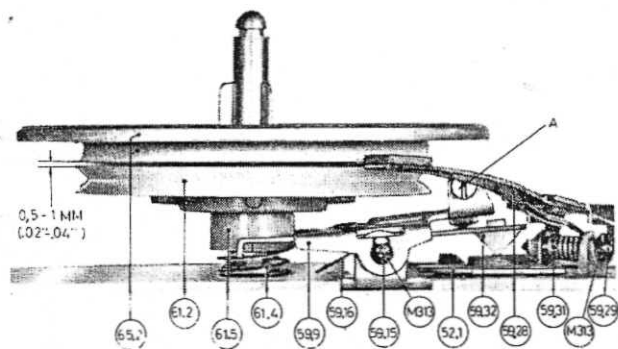

Fig. 23.

The supply turntable

The supply turntable (65.2) is completely disengaged from the pulley disc (61.2) and free running in this position.

The trip bar (52.1) has moved, and the delrin button (59.32) on the clutch lever (59.9) is at the highest position, pressing down the two delrin lugs on the cartridge (61.5).

Adjustments:

Adjust the height of the clutch lever (59.9) by the screw (A) until the clearance between the pulley disc (61.2) and the feltring on the turntable (65.2) is approx. 0,5–1 mm (0,02"–0,04"). Recheck all other positions of the operating lever and finally seal the adjustment screw.

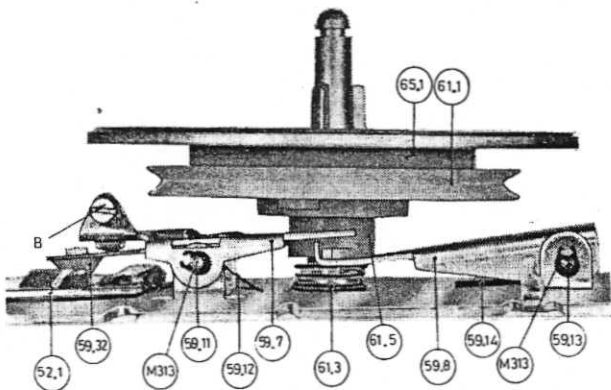

Fig. 24.

The take-up turntable

The take-up turntable (65.1) has maximum obtainable friction with the pulley disc (61.1) in this position. The springloaded lower clutch lever (59.8) is pressing the delrin lugs on the cartridge (61.5) upwards in addition to the entire tension of the compression spring (61.3). The trip bar (52.1) has moved, and the delrin button (59.32) on the upper clutch lever (59.7) is at the lowest position, disengaged from the lower clutch lever (59.8) and the two delrin lugs on the cartridge (61.5).

Adjustments:

Adjust the height of the upper clutch lever (59.7) by the screw (B) until the clearance between the upper and the lower clutch levers (59.7, 59.8) is approx. 0,5 mm (0,02").

The torque of the take-up turntable (65.1) should be minimum 65 g (2¹/₄ OZ) acting on an arm of 8 cm (3¹/₂"). Recheck all other positions of the operating lever and finally seal the adjustment screw.

4.3.4 Normal forward drive

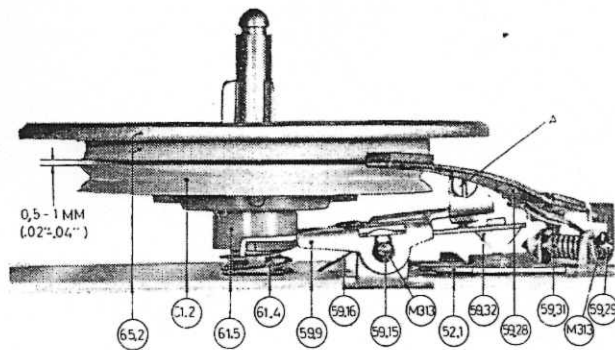

Fig. 25.

The supply turntable

The supply turntable (65.2) is completely disengaged from the pulley disc (61.2) and free-running in this position.

The trip bar (52.1) has moved, and the delrin button (59.32) on the clutch lever (59.9) is at the highest position, pressing down the two delrin lugs on the cartridge (61.5).

Adjustments:

Adjust the height of the clutch lever (59.9) by the screw (A) until the clearance between the pulley disc (61.2) and the feltring on the turntable (65.2) is approx. 0,5–1 mm (0,02"–0,04"). Recheck all other positions of the operating lever and finally seal the adjustment screw.

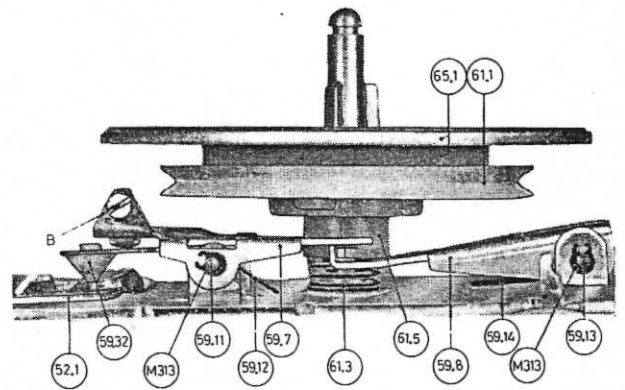

Fig. 26.

The take-up turntable

The take-up turntable (65.1) has a reduced friction with the pulley disc (61.1) in this position. The torque of the take-up turntable (65.1) should be sufficient to take up the tape in record or playback modes.

The trip bar (52.1) has moved, and the delrin button (59.32) on the upper clutch lever (59.7) is in the middle position, pressing down the spring loaded lower clutch lever (59.8). The delrin lugs on the cartridge (61.5) are released from any tension, and the pulley disc (61.1) is pressed against the turntable (65.1) by the tension of the compression spring (61.3) only.

Adjustments:

Adjust the height of the upper clutch lever (59.7) by the screw (B) until the delrin lugs on the cartridge (61.5) is in the center position between upper and lower clutch levers (59.7, 59.8).

The torque of the take-up turntable (65.1) should be 12–25 g (1/2–1 OZ) acting on an arm of 8 cm (3 1/2"). Recheck all other positions of the operating lever and finally seal the adjustment screw.

4.3.5 Neutral

The motor power is shut off, and the pulley discs (65.1, 65.2) are not running.

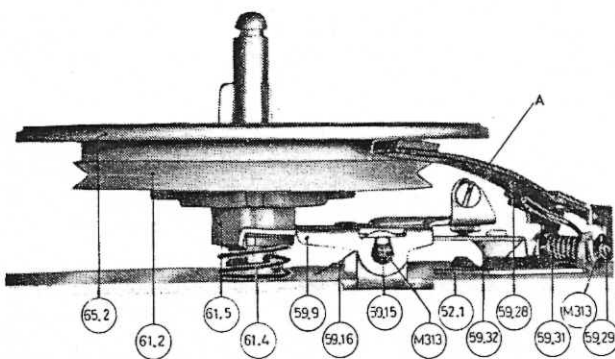

Fig. 27.

The supply turntable

The supply turntable (65.2) has maximum obtainable friction with the pulley disc (61.1) in this position. Ref. chapter 4.3.2, fast rewind.

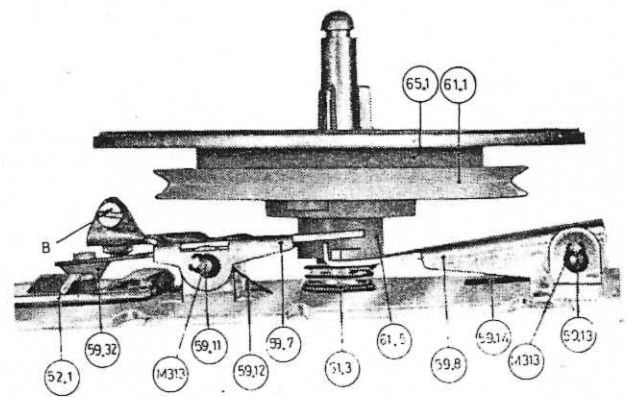

Fig. 28.

The take-up turntable

The take-up turntable (65.1) has maximum obtainable friction with the pulley disc (61.1) in this position. Ref. chapter 4.3.3, fast wind.

4.3.6 Free

The motor power is shut off and the pulley discs (65.1, 65.2) are not running.

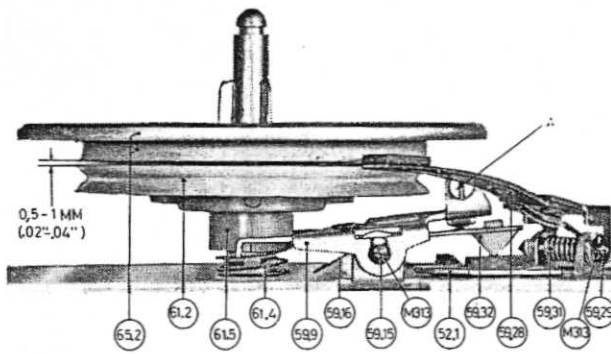

Fig. 29.

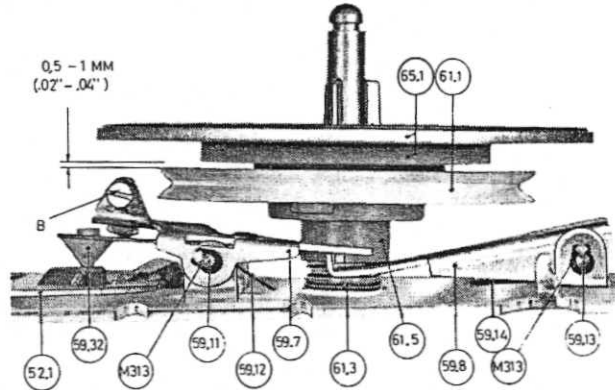

Fig. 30.

The supply turntable

The supply turntable (65.2) is completely disengaged from the pulley disc (61.2) and free-running in this position. Ref. chapter 4.3.3, fast wind.

The take-up turntable

The take-up turntable (65.1) is completely disengaged from the pulley disc (61.1) and free-running in this position. Ref. chapter 4.3.2, fast rewind.

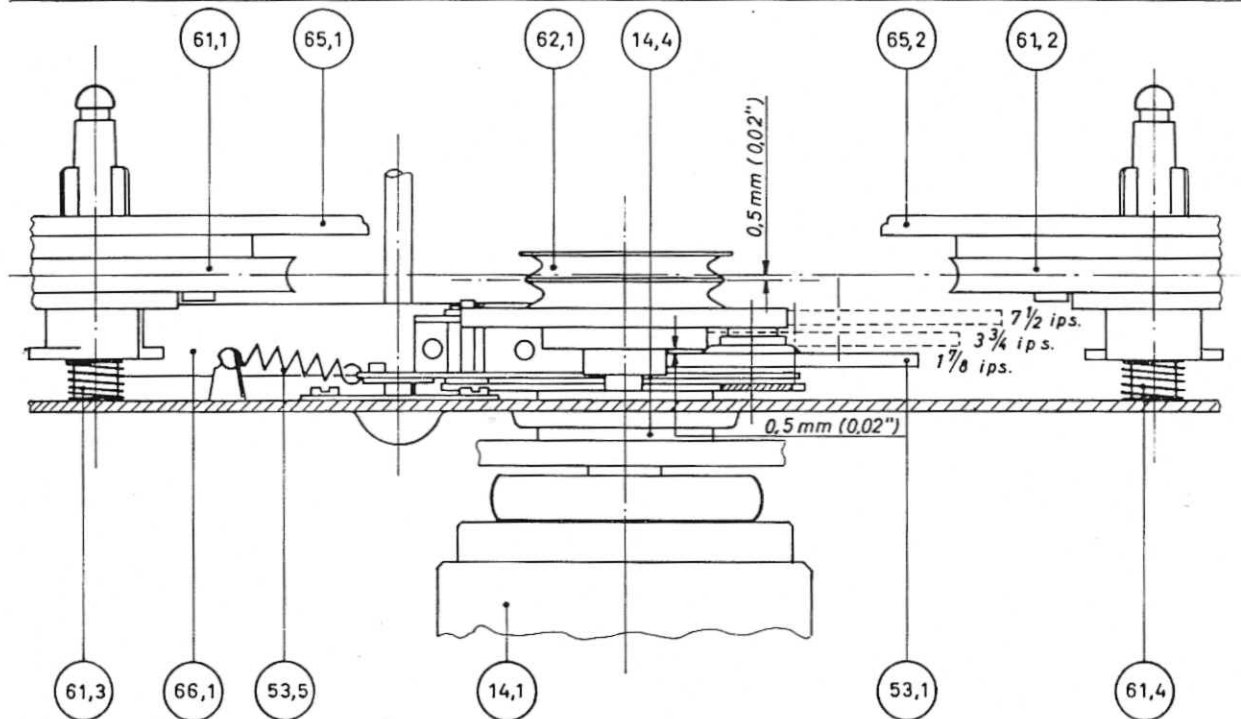

Fig. 31. The alignment of the motor pulley.

4.4 THE MOTOR PULLEY

The driving mechanism with the speed transfer wheel (53.1) engaged in the $1\frac{7}{8}$ i.p.s. track on the motor pulley (62.1) is shown in fig.31. The motor pulley (62.1) has three tracks with different diameters for the speed transfer wheel (53.1), corresponding to the speeds $1\frac{7}{8}$, $3\frac{3}{4}$ and $7\frac{1}{2}$ i.p.s.

Adjustments:

The vertical position of the motor pulley (62.1) is adjusted with the operating lever (54.1) in neutral position. The dividing rib of the motor pulley (62.1) should be set 0.5 mm (0.02") below an imaginary line drawn between the bottoms of the V-shaped grooves in the pulley discs (61.1, 61.2).

4.4.1 Threading of the rubber drive belt

The rubber drive belt (62.2) is crossthreaded as shown in fig.6. The belt is running in the upper groove in front of the pulley (62.1), and in the lower groove at the rear of the pulley. The crossing should lie between the supply turntable (65.2) and the motor pulley (62.1).

4.5 THE SPEED TRANSFER WHEEL

The speed transfer wheel (53.1) is attached to the mounting arm (53.3) and is driven by the motor pulley (62.1). The speed transfer wheel (53.1), in turn, drives the flywheel (66.1). The spring (53.5) secures the contact of the speed transfer wheel (53.1) between the motor pulley (62.1) and the flywheel (66.1). Ref. fig. 6 and 31.

Adjustments:

The speed selector bracket (79.11) is adjusted until the mounting arm for the speed transfer wheel (53.3) is parallel to the lower mounting plate (71.1) (unscrew the two screws M113). The spacing between the mounting arm (53.3) and the lower mounting plate (71.1) should be approx. 1 mm (0,04") in the position $1\frac{7}{8}$ i.p.s. Ref. fig. 34 and 6.

The vertical position of the speed transfer wheel (53.1) is adjusted by adding or subtracting turbax washers (M301-2-3) between the transfer wheel holder (53.2) and the mounting arm for the transfer wheel holder (53.3), and between the transfer wheel and the transfer wheel holder (53.2).

The spacing between the speed transfer wheel (53.1) and the higher speed track on the motor pulley (62.1) should be approx. 0,5 mm (0,02") in the $1\frac{7}{8}$ i.p.s. and $3\frac{3}{4}$ " i.p.s. position.

The vertical position of the speed transfer wheel (53.1) in the $7\frac{1}{2}$ i.p.s. position should be minimum 1 mm (0,04") below the upper rim of the flywheel (66.1). The flywheel (66.1) is lifted, if necessary, by adding an extra thrust washer (66.12) in the lower flywheel bearing. Ref. chapter 4.7.

The horizontal alignment of the speed transfer wheel (53.1) is adjusted by bending the transfer wheel holder (tool No. 6) until the speed transfer wheel (53.1) runs parallel to the flywheel (66.1).

4.6 THE LIFTING MECHANISM

The design of the lifting mechanism is shown in fig. 34.

The lifting arm (59.25) with the parallel arm (53.7) and the adjustment arm (53.8) is located between the upper and the lower mounting plates (71.2, 71.1). The lifting arm (59.25) is linked to the eccentric segment (59.1) while the parallel arm (53.7) is connected between the lifting arm (59.25) and the transfer wheel holder (53.2).

The lifting mechanism releases the speed transfer wheel (53.1) from contact with the motor pulley (62.1) and the flywheel (66.1) in all positions of the operating lever (54.1) except normal forward drive.

Adjustments

Ref. fig. 34.

Loosen screw A. The lifting between the speed transfer wheel (53.1) and the motor pulley (62.1) is individually adjusted for the three speeds by bending the splits X, Y and Z on the lifting arm (59.25), corresponding to the speeds $7\frac{1}{2}$, $3\frac{3}{4}$ and $1\frac{7}{8}$ i.p.s. The lifting is occasioned by a relatively small movement of the operating lever (54.1) from normal forward drive to neutral. The lifting should be completed before the motor current is shut off by the microswitch (33.3).

The clearance between the motor pulley (62.1) and the speed transfer wheel (53.1) at all speeds should be minimum 3 mm when the operating lever (54.1) is in neutral position.

Set the speed selector to $1\frac{7}{8}$ i.p.s. tape speed and the operating lever to neutral position. Turn the adjustment arm (53.8) until a spacing of 0,5 mm

Fig. 32. The flywheel with the bearings, exploded view.

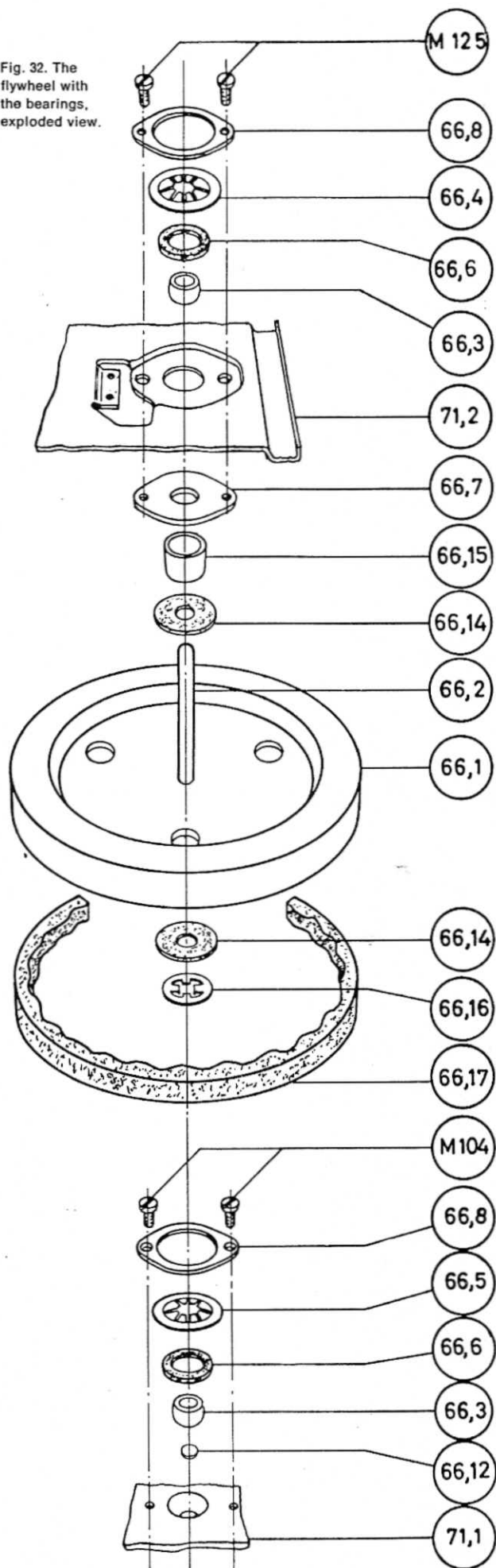

6x

(0,02") is obtained between the speed transfer wheel (53.1) and the flywheel (66.1). Turn the speed selector to $3\frac{3}{4}$ and $7\frac{1}{2}$ i.p.s. tape speed and check that the spacing is min. 0,5 mm (0,02") for both positions. Readjust if necessary and re-seal the adjustment screw A.

with the lowest track on the motor pulley (62.1), and the mounting arm for the speed transfer wheel (53.3)

4.7 THE FLYWHEEL WITH THE CAPSTAN

The flywheel shaft acts as the capstan (62.2), and is mounted in two selflubricated and selfadjusting bearings (66.2). Ref. fig. 32.

Adjustments

The vertical position of the capstan (66.2) is aligned with the special tool No. 5 inserted on top of the capstan as shown in fig. 33. The two screws (M125) are loosened, and correct position of the capstan (66.2) is obtained when all three legs of tool No. 5 touches the upper mounting plate (71.2).

4.8 THE SPEED CHANGE MECHANISM

The speed change mechanism is designed as shown in fig. 34. The speed transfer wheel (53.1) is engaged

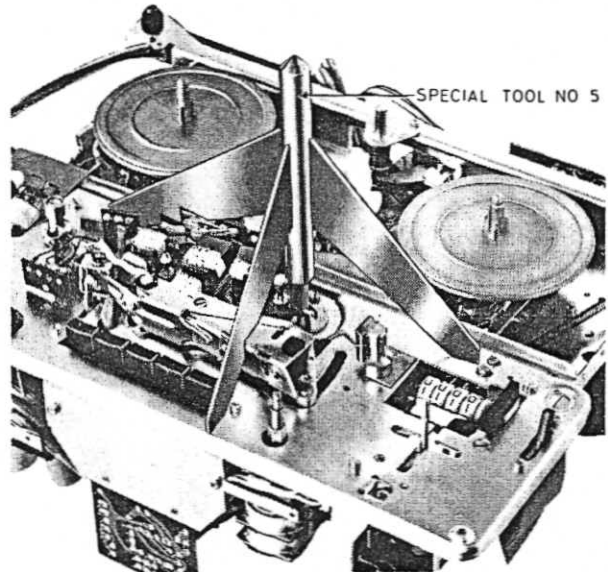

Fig. 33. Alignment of the capstan with tool No. 5.

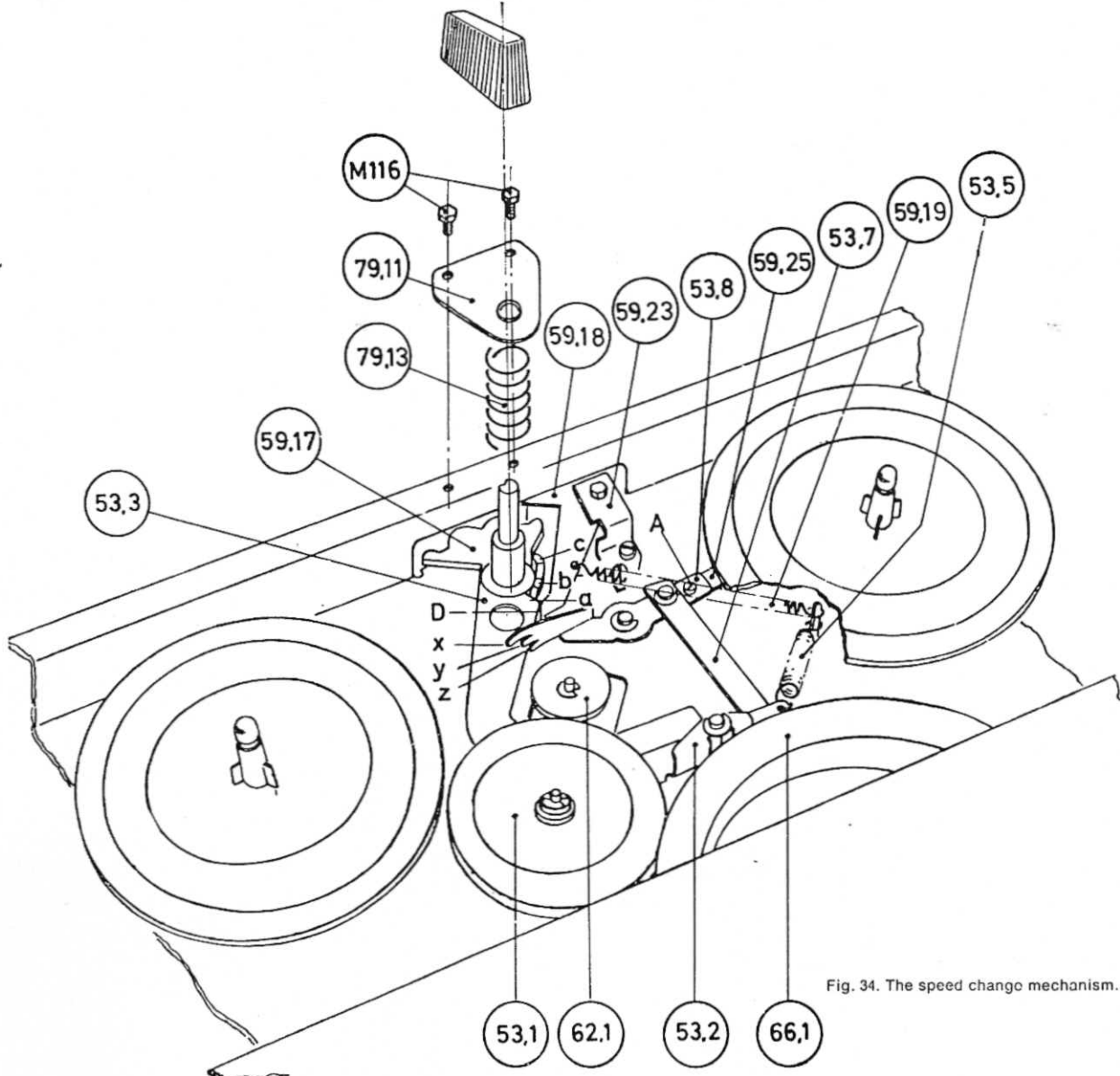

Fig. 34. The speed change mechanism.

20

is pressed against the lowest level (level a) on the cam disc (59.17) in the $1\frac{7}{8}$ i.p.s. position.

The speed transfer wheel (53.1) will be disengaged from the motor pulley (62.1), and moved out horizontally approx. 1", when the speed selector knob (53.4) is turned toward the $3\frac{3}{4}$ i.p.s. position. This horizontal movement is accomplished by the cam disc arm (59.18), which roller rests against the curvature of the cam disc (59.17). The cam disc arm (59.18) presses against the mounting arm for the speed transfer wheel (53.3) in point D.

The vertical lifting of the mounting arm for the speed transfer wheel (53.3) is accomplished by the slope of the cam disc (59.17) between the levels a and b. The

slope presses the mounting arm for the speed transfer wheel (53.3) upwards from the level a ($1\frac{7}{8}$ i.p.s. position) to the level b ($3\frac{3}{4}$ i.p.s. position) during the rotation of the speed selector knob.

Adjustments

The spacing at point D between the cam disc arm (59.18) and the mounting arm for the speed transfer wheel (53.3) should be 0,5 mm (0,02") with the operating lever (54.1) in normal forward drive. The spacing is adjusted by bending the nose of the cam disc arm (59.18). Remove the motor pulley (62.1) to make this alignment.

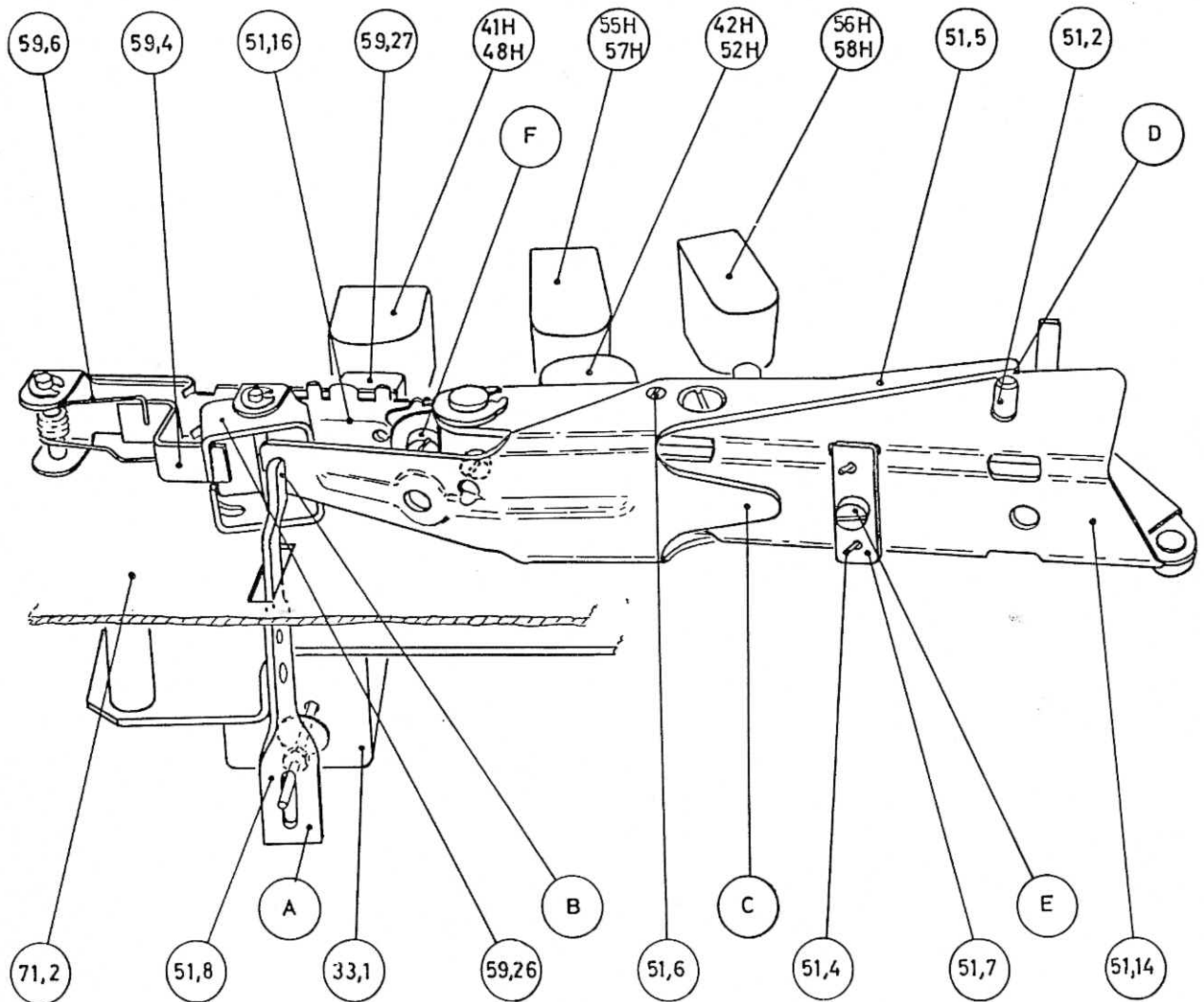

Fig. 35. The momentary start-stop mechanism.

4.9 THE MOMENTARY START-STOP FEATURE

The momentary start-stop mechanism is designed as shown in fig. 35. The start-stop magnet (33.1) has a push-type armature which activates the start-stop lever (51.8) at point A, when the start-stop push-button is released. The start-stop lever, will in turn, press against the pressure wheel lever (51.5) in point B. The pressure wheel lever moves the pressure wheel shaft (51.2) with the pressure wheel (51.1) away from the capstan (66.2) and activates the tape brake (51.13) which prevents the tape from creeping. (Ref. chapter 4.1.4, the tape brake.) From serial no approx 2406576, the start-stop mechanism is modified (see 4.1.4).

Adjustments

The start-stop magnet (33.1) is energized, and the armature fully attracted, when the operating lever (54.1) is in normal forward drive and the start-stop push-button released. Adjust the pressure wheel lever (51.5) by bending the flat part B to obtain a spacing of approx. 0,5 mm (0,02") between the pressure wheel (51.1) and the capstan (66.2). Start the mechanism by depressing the start-stop push-button. Adjust the pressure wheel lever (51.5) by bending the tongue C to obtain a spacing of approx. 1 mm (0,04") between the pressure wheel shaft (51.2) and the pressure wheel lever (51.5) at point D.

4.10 THE PRESSURE PAD

The pressure pad (59.5) is located in front of the erase head and is introduced to secure maximum erasure, and to ensure constant friction for the tape, when the recorder is operating in normal forward drive. Ref. fig. 11 and 35.

The pressure pad arm (59.4) is activated by the pressure wheel lever (51.5) and the transfer bracket (59.26). The pressure pad (59.5) is pressing against the tape and the erase head in normal forward drive, and is completely disengaged in all other position of the operating lever (54.1).

Adjustments

The pressure pad (59.5) should be cleaned occasionally, as the accumulation of dust and iron oxide particles might seriously affect the erasure and the tape movement.

Note: Do not soak the felt pad with any liquid.

The spring with felt for the pressure pad (59.27) is designed as a snap-on type, and can easily be pulled out by bending the two tags on the bronze spring away from the slots in the pressure pad arm (59.4). The tension of the pressure pad (59.5) against the erase head, in normal forward drive position, should be 75–100 g ($5\frac{5}{8}$ – $3\frac{1}{2}$ OZ). This tension is adjusted by increasing the tension of the spring for the pressure pad (59.27).

4.11 THE AUTOMATIC END STOP SWITCH

The actuating spring for the end stop switch (59.32) is located in the slot of the right tape guide (59.4). The microswitch (33.16) for the end stop is mounted under the upper mounting plate (71.2). Ref. fig. 9 and 11. The microswitch (33.16) shuts off the motor when the tape runs out or if the tape should break. The switch works independent upon the position of the operating lever (54.1).

Adjustments

The operating point for the microswitch (33.16) is adjusted by bending the actuating spring (79.32) in point A. Ref. fig. 36. The operating point is set 0,5 mm

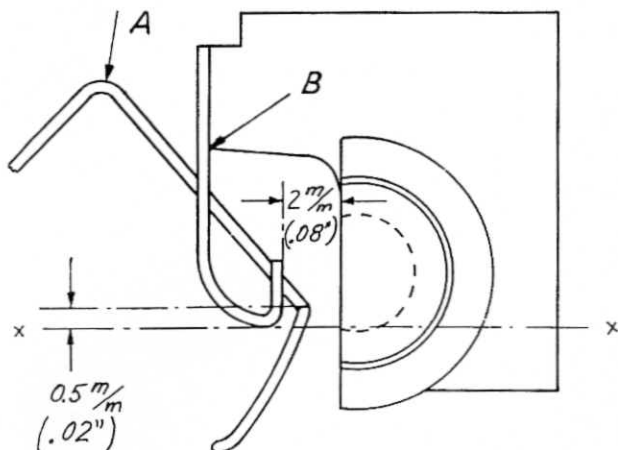

Fig. 36. Horizontal adjustment of the end stop switch.

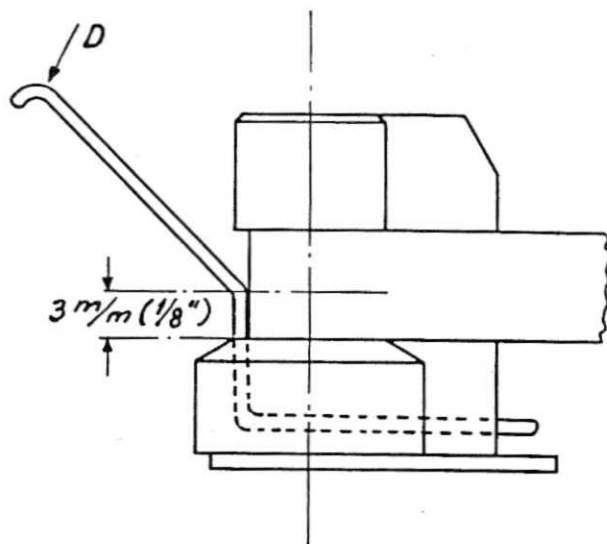

Fig. 37. Vertical adjustment of the end stop switch.

(0.02") in front of the imaginary line x-x, when the actuating spring (79.32) is moved from the rest position towards the front of the upper mounting plate (71.2).

The actuating spring shall run free inside the tape guide slot without sticking. The width of the slot is adjusted to 2 mm (0,08") by bending the bracket in point B. Ref. fig. 36.

The vertical position of the actuating spring (79.32) is adjusted as shown in fig. 37. The vertical part of the spring should cover approx. 3 mm ($\frac{1}{8}$ ") of the tape. Misalignments could cause the tape to be squeezed out of the tape guide.

Ascertain sufficient clearance between the upper part of the actuating spring marked D and the front trim cover (73.1) when tape is inserted.

4.12 THE REVOLUTION COUNTER

The revolution counter (79.14) is located between the upper and the lower mounting plates (71.2, 71.1), behind the operating lever (54.1). The counter (79.14) is driven by a rubber belt (69.3) and a pulley disc (69.1) attached to the shaft of the take-up turntable (65.1). Ref. fig. 9 and 57.

Adjustments

The pulley disc for the revolution counter (69.2) is mounted flush with the counter shaft. The pulley disc (69.1) is mounted as shown on fig. 16. Misalignment of the vertical position of the pulleys might cause the rubber belt to fall off.

4.13 ASSEMBLING THE TOP COVER

The top cover is attached to the recorder as shown in fig. 38.

Vertical alignment of the top cover.

Two thick rubber washers (74.6) have been introduced between the top cover and the mounting brackets. By tightening the two screws (74.5) slightly, the rubber will be compressed and allow the necessary vertical adjustment of the top cover. Ref. fig. 38. The vertical position of the top cover should be adjusted to ascertain sufficient spacing between the plastic tape reels and the top cover in all modes of operation.

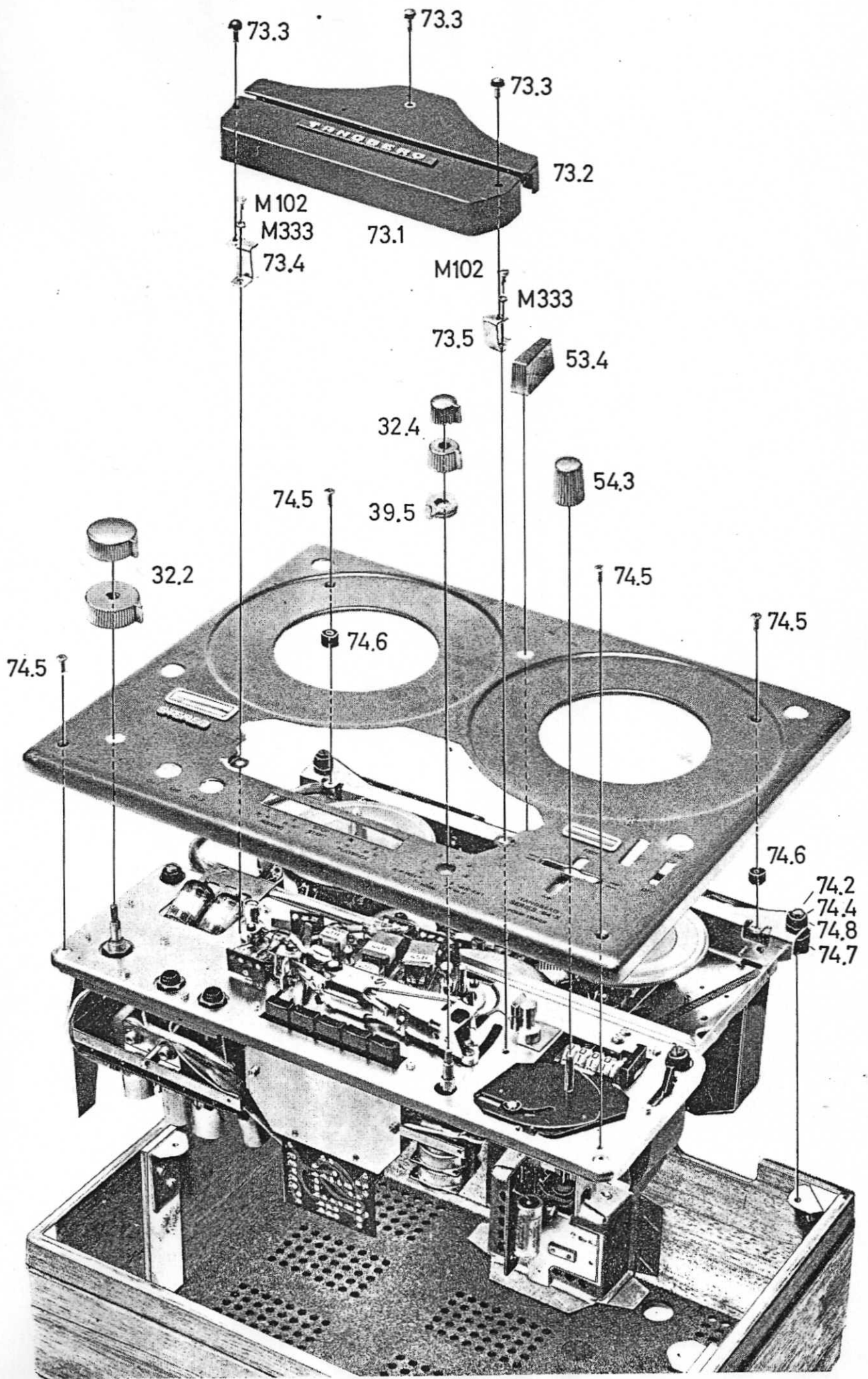

Fig. 38.

5.0 The electronic circuits, detailed description and adjustment instructions

5.1 THE MAIN ELECTRONIC UNITS, BLOCK DIAGRAM

The simplified block diagram for the Tandberg tape recorder models 64x and 62x is shown below, ref. fig. 39.

The tape recorder is equipped with the following units:

- 2 Record pre-amplifiers
- 2 Record amplifiers
- 2 Record level indicator circuits

- 1 Oscillator, bias and erase circuit
- 2 Playback pre-amplifiers
- 2 Cathode followers
- 1 Center channel amplifier
- The momentary start-stop circuit
- The power supply
- The switching system

The different units can be interconnected in various combinations by the switching system, creating a very flexible tape recorder.

The amplifiers are identical for the two channels and only the amplifiers for the upper track are therefore explained in the following discussions.

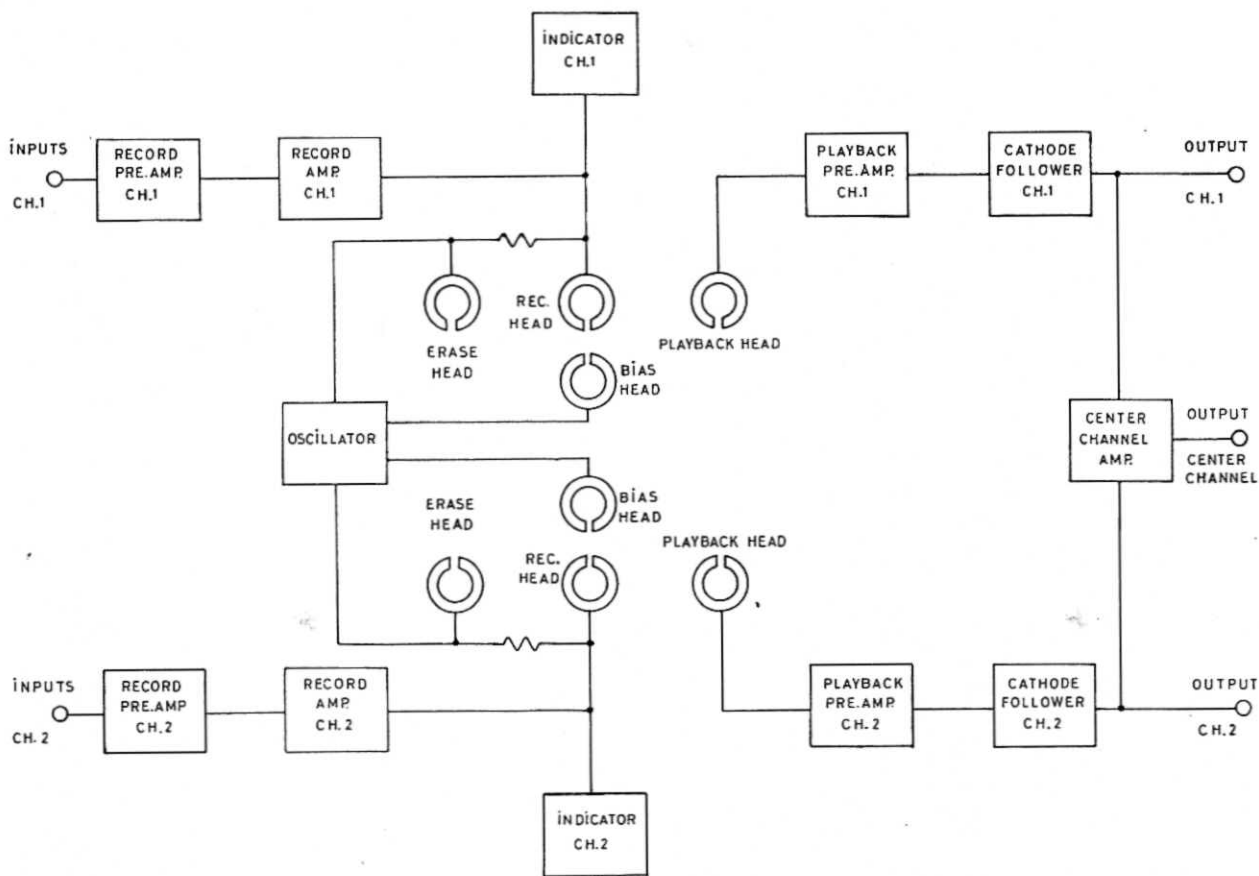

Fig. 39. Block diagram, models 64x and 62x.

5.1.1 The record pre-amplifier

The schematic for the record pre-amplifier is shown below. Ref. fig. 40.

The record pre-amplifier is a two stage amplifier using the double triode ECC83 (12AX7). The record gain control R109 controls the input to the second amplifier stage. The record pre-amplifier has the following three inputs: High level, low level and microphone input. The high level input signal is reduced to 1/27 by R1 and R3. The low level signal is reduced to 1/2,7 by R2 and R3. The microphone input is connected directly to the input of the first tube. Programme mixing is possible through the high and low level inputs. The

microphone jack disconnects the high and low level inputs from the grid of the first amplifier stage when the microphone plug is inserted. The output signal from the record pre-amplifier passes the record level adjustment potentiometer R115, and is fed to the input of the record amplifiers. The output from the record pre-amplifier (point 5) can be connected to the cathode follower input by the switching system. The frequency response of the record pre-amplifier is flat. No equalization has been introduced. The capacitor C1, C2 and C105 will give a slight boost of the high frequencies, to compensate for the high frequency losses caused by the wiring of the amplifier.

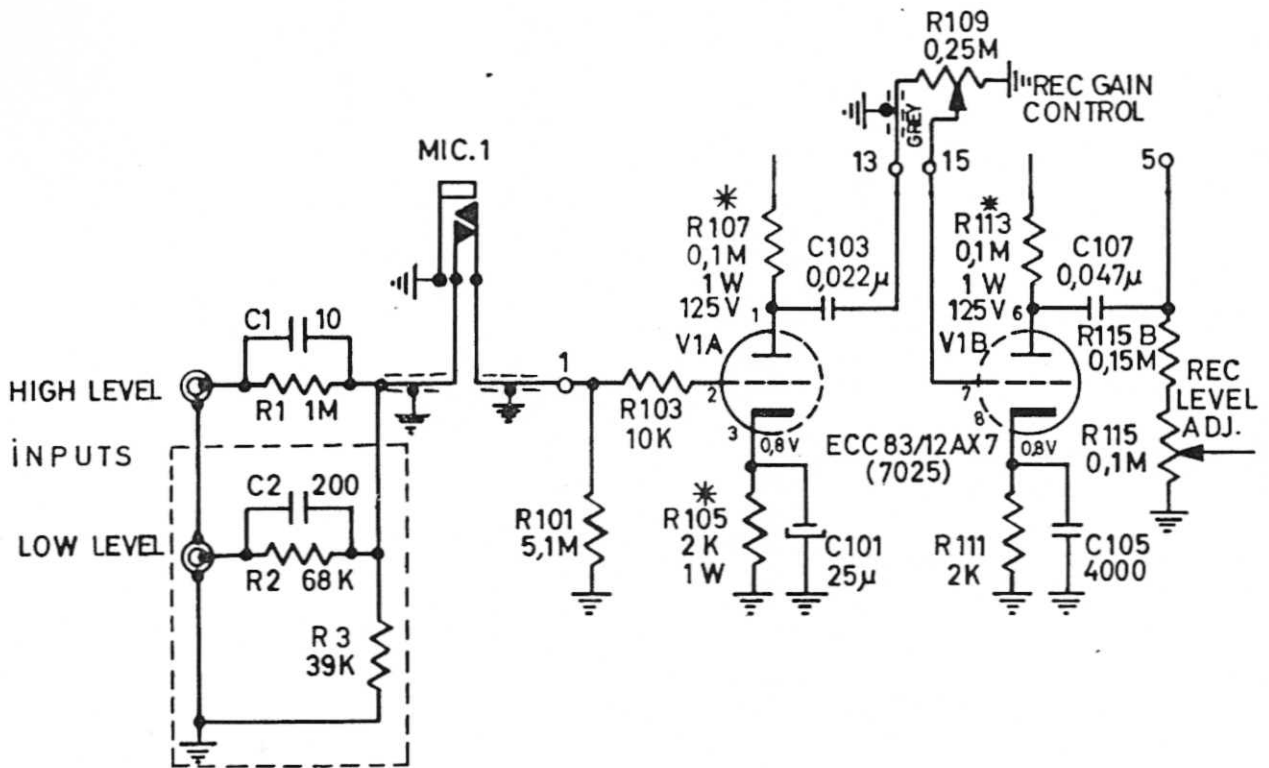

Fig. 40. The record pre-amplifier, schematic.

5.1.2 The FM-multiplex filter

The two low level inputs have been replaced by 19 kHz FM-multiplex filters on tape recorders sold in certain territories.

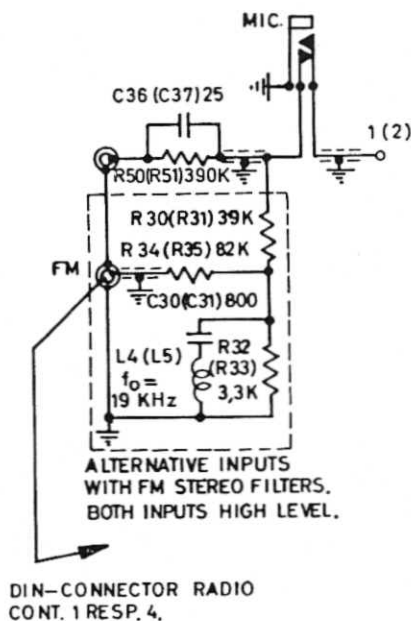

Fig. 41. The 19 kHz FM-multiplex filter, schematic.

The 19 kHz signal that might appear on the output terminals on the FM-multiplex tuner is rejected by the series resonant circuit C30 and L4. Ref. fig. 41.

The 33 1/3 kHz signal which might appear on the output terminals of the FM-multiplex tuner in certain areas is rejected by the parallel resonant circuit C34 and L7.

The 33 1/3 kHz filter is connected in series with the capacitor C103 and the REC. GAIN control R109. Ref. fig. 42.

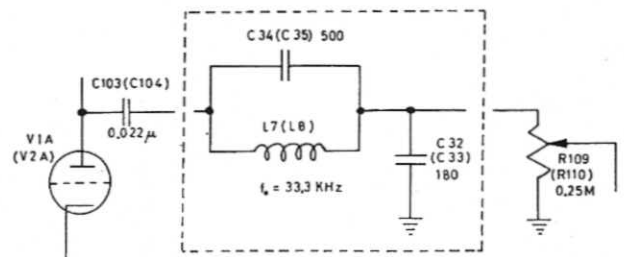

Fig. 42. The 33 1/3 kHz FM-multiplex filter, schematic.

5.1.3 The record amplifier

The schematic for the record amplifier is shown below. Ref. fig. 43.

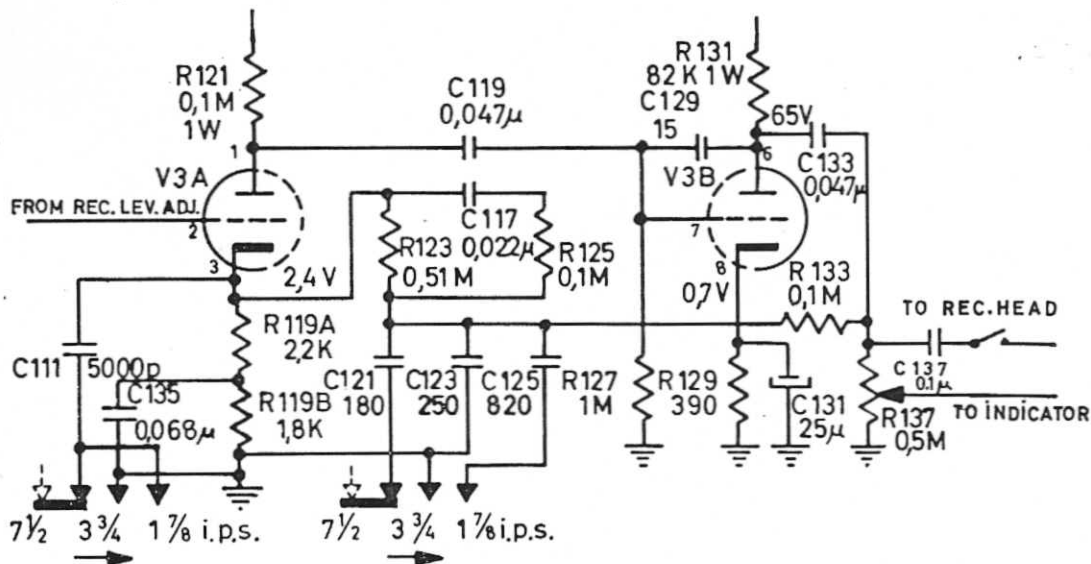

Fig. 43. The record amplifier, schematic.

The record amplifier is a two stage amplifier using the double triode ECC81 (12AT7). The input signal is fed directly to the grid of V3A from the record level adjustment potentiometer R115.

The entire record equalization is obtained by the negative feedback circuits connected from the anode of V3B to the cathode of the V3A. Mainly the high frequencies are compensated in the record amplifier. Ref. fig. 44.

The speed compensation is obtained by the combination of C111—C135- and C121—C123—C125 in the frequency dependent feedback circuit. The equaliza-

tion switch is linked to the speed selector switch, and correct combination of the capacitors is automatically obtained when the tape speed is changed.

The frequency compensation of approximately + 3 dB at 30 Hz is obtained by the capacitor C117.

The capacitor C129 acts as a high frequency stabilizer for the amplifier.

The record head is connected in series with C137 and R46 to ground. The indicator circuit is connected to the center tap of the potentiometer R137.

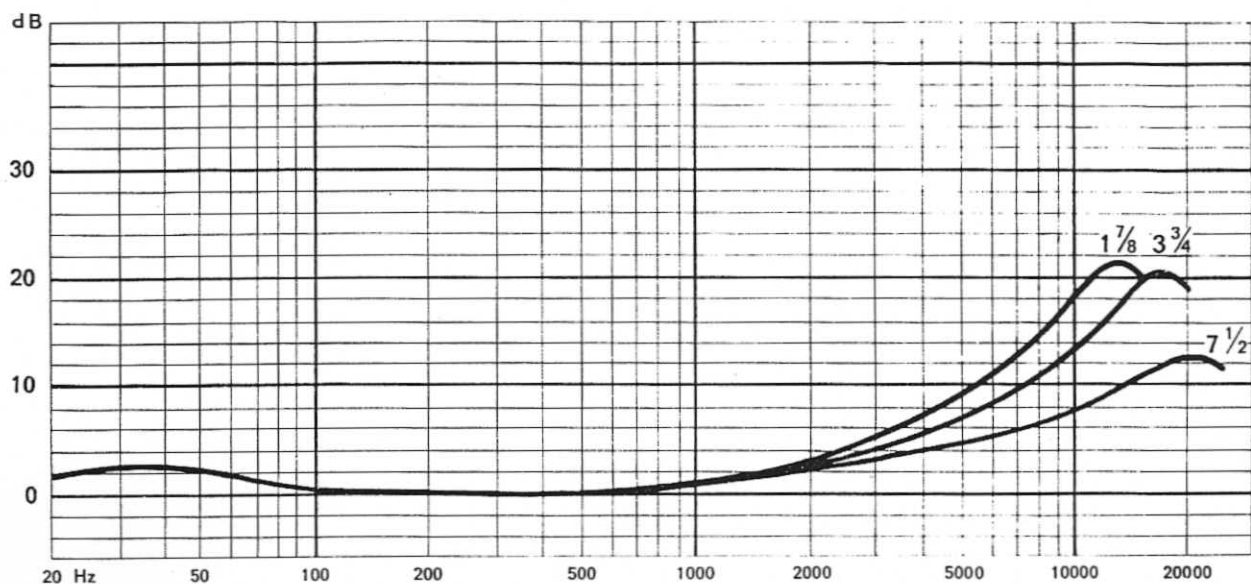

Fig. 44. The response curves for the record amplifier.

5.1.4 The playback pre-amplifier

The schematic for the playback pre-amplifier is shown below. Ref. fig. 45.

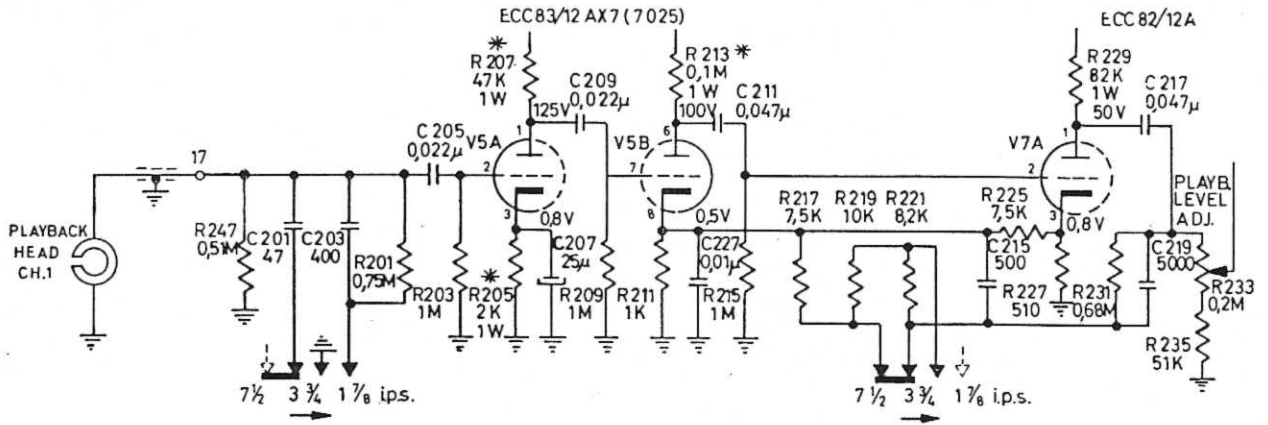

Fig 45. The playback pre-amplifier, schematic.

The playback pre-amplifier is a three stage amplifier using one double triode ECC83 (12AX7) and one section of the double triode ECC82 (12AU7).

The entire playback equalization is obtained by the combination of the following circuits in the playback pre-amplifier.

- 1) The positive feedback from the cathode of V7A to the cathode of V5B (R225) increases the amplification of the low frequencies.
- 2) The variable negative feedback circuit from the anode of V7A to the cathode of V5B (R217-R219-R221-R231-C219-C227) will give the correct high frequency response at the different tape speeds.
- 3) The playback head together with the capacitors C201, C203 and the resistor R201 forms a variable

resonant circuit and compensate for playback losses at high frequencies.

The equalization switch is linked to the speed selector switch and correct equalization for the different speeds is automatically obtained when the tape speed is changed. Ref. fig. 46.

The output voltage from the cathode follower is adjusted to 1,4 V by R233 with the playback volume controls set to maximum, when a pre-recorded tape (400 Hz, test tape No. 4) is played back. The muting switch is shortcircuiting the output from the playback pre-amplifier to ground in all positions of the operating lever, except in position normal forward drive. The switch is introduced to prevent noise from the playback amplifiers when the tape recorder is used as a pre-amplifier.

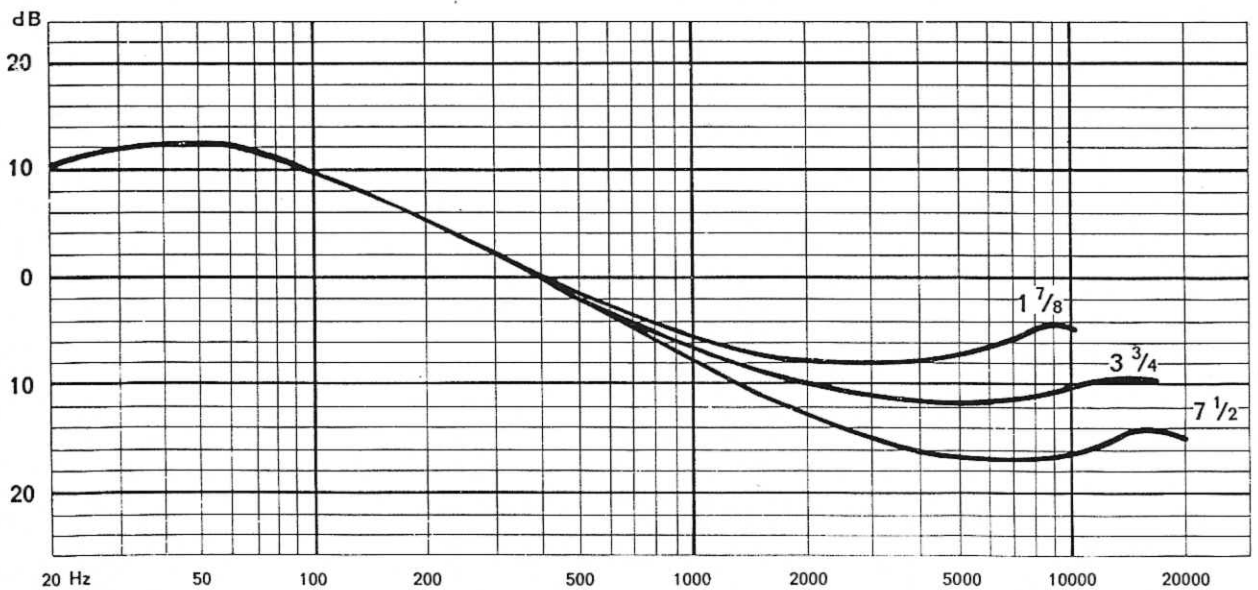

Fig. 46. The response curves for the playback pre-amplifier.

5.1.5 The cathode follower

Ref. fig. 47.

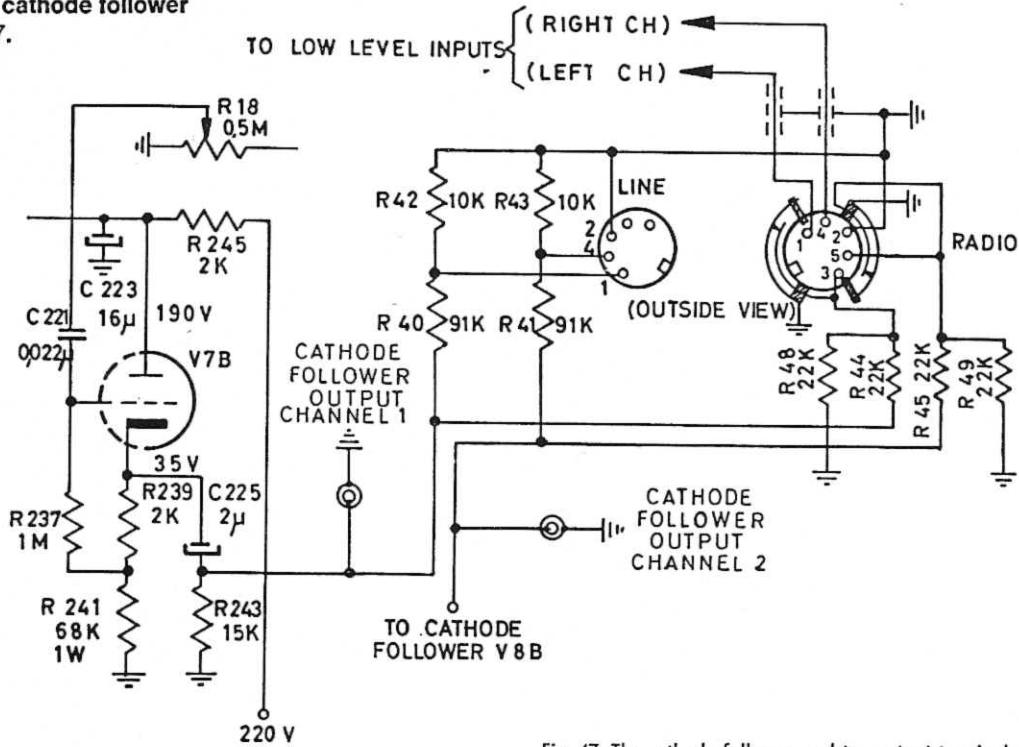

Fig. 47. The cathode follower and the output terminals, schematic.

One section of the double triode ECC82 (12AU7) is used as a cathode follower. The input voltage is adjusted by the playback volume control R18. The capacitor C225 blocks DC voltage from the output terminals.

The minimum load resistance on the cathode follower output is 2 kohms and the output level is 1.5 V. The output impedance on the RADIO DIN-contact is 11 kohms and the output level is 750 mV. The output impedance on the LINE DIN-contact is 10 kohms and the output level is 150 mV.

5.1.6 The center channel amplifier

Ref. fig. 48.

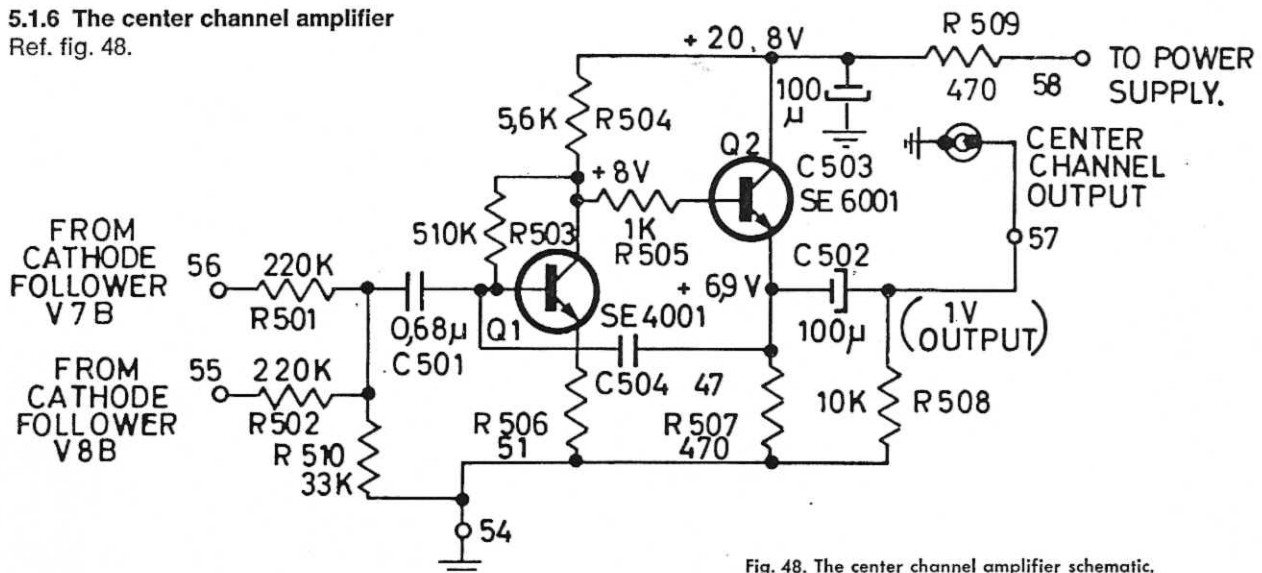

Fig. 48. The center channel amplifier schematic.

The center channel amplifier is a two stage transistor amplifier using the transistors Q1 and Q2. Q1 is connected in common emitter connection while Q2 is common collector connected (emitter follower). The resistor R503 is introduced to stabilize the current amplification in Q1. The capacitor C504 is a filter capacitor for high frequency signals.

The center channel amplifier is fed from the cathode followers. The signals are mixed, amplified and fed to the CENTER CHANNEL OUTPUT. The output level is 1 volt with 200 ohms load. The frequency response of the center channel amplifier is flat within the audio range.

5.1.7 The record level indicator circuit

Ref. fig. 49.

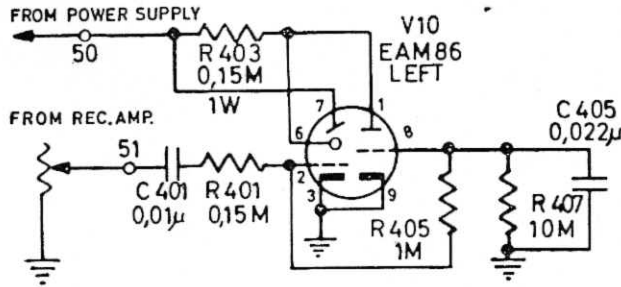

Fig. 49. The electronic beam indicator circuit, schematic.

The EAM86 is a combined rectifier, triode and indicator tube. The input of the indicator circuit is connected to the center-tap of R137 in the record amplifier. The signal is first rectified in the diode section of the EAM86. The DC signal is filtered by the damping circuit R407, C405 and connected to the grid of the amplifier section. The amplifier anode is connected directly to the indicator anode. The indicator target is connected to +230 V from the power supply. The record level indicator is adjusted by R137 to close at a recording level corresponding to 3% distortion from the tape when a pre-recorded tape with a 400 Hz signal is played back.

The indicator maintains the sensitivity over the entire audio range from 30 Hz to 20.000 Hz.

5.1.8 The oscillator, bias and erase circuit

The schematic of the oscillator with the bias and erase circuits is shown in fig. 50.

The oscillator is of the push-pull type, using two transistors Q605 and Q606.

The DC supply is fed to the center-tap of the transformer T601. Variations of the output voltage from the oscillator caused by the variation of the oscillator load between monaural and stereo recording is compensated by the dummy load R613, C609 and L601. The oscillator frequency is adjusted to 85,5 kHz with the trimming capacitor C610. The bias circuit CH1 (CH2) consist of a pair of complementary transistors Q601 and Q602, CH1 (Q603 and Q604 CH2). The oscillator signal is fed to the complementary stage, and the bias is adjusted with the resistor R609 CH1 (R612 CH2) when the speed selector switch is set to position 7 1/2 or 3 3/4 i.p.s. tape speed. When the speed selector switch is set to position 1 7/8 i.p.s. tape speed the resistors R607 and R609 CH1 are partially connected in parallel to reduce the bias 20%.

The bias current is adjusted by the trimming capacitor C604 CH1 (C602 CH2).

The magnetic fields produced by the two erase head halves are 180° out of phase to prevent unwanted erasure of the track in between the two tracks being recorded.

Note: The magnetic fields produced by the two erase head halves on the two-track version are in phase.

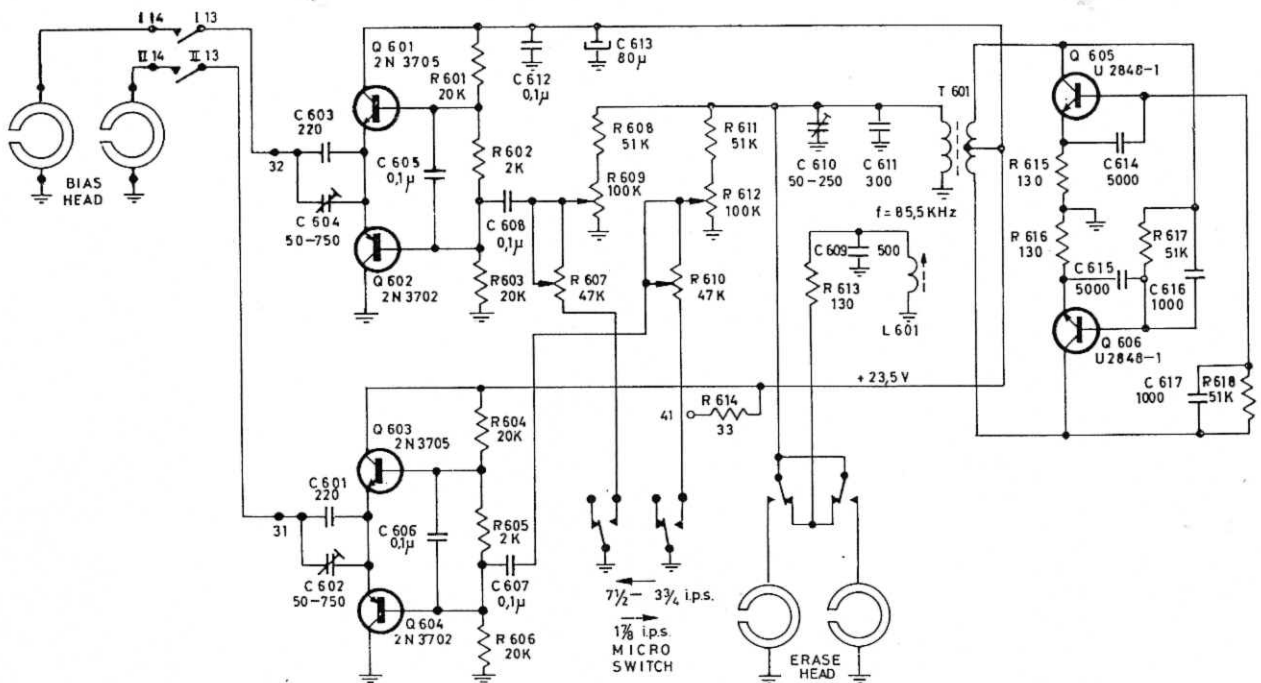

Fig. 50. The oscillator, bias and erase circuit, schematic.

5.1.9 The momentary start-stop circuit

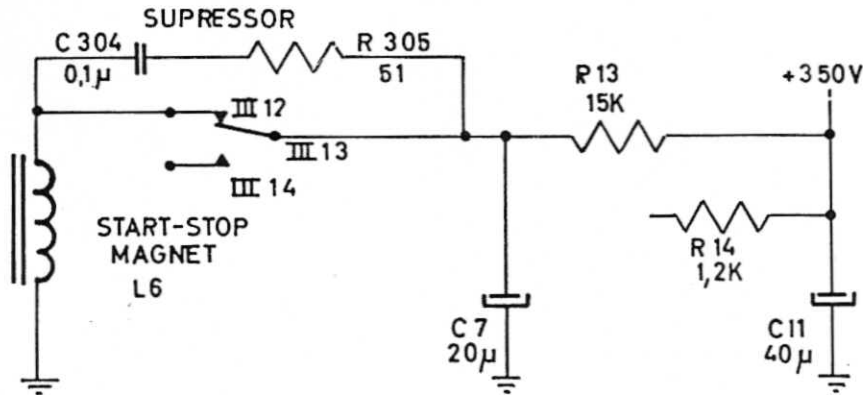

Fig. 51. The momentary start-stop circuit, The start-stop push-button released (stop position).

The schematic for the momentary start-stop circuit is shown above. Ref. fig. 51.

The mechanical operation of the momentary start-stop feature is described in chapter 4.9. The operating lever is set to position normal forward drive.

- 1) The start-stop push-button is released:
The start stop magnet (33,1) retains attracted by the current through the bleeder resistor R13. The tape is not moving due to the pressure wheel (51,1) being engaged from the capstan (66,2).
- 2) Start-stop push-button is depressed:
The start-stop magnet (33,1) is disconnected by the contact III 13 which has moved to III 14. The tape is moving due to the pressure wheel (51,1) being engaged with the capstan (66,2). The capacitor C7 is charged to 350 V DC over R13.

- 3) Releasing the start-stop push-button:
The contact III 13 is moved back to position III 12. The charged energy in C7 attracts the start-stop magnet (33,1). The pressure wheel (51,1) disengages from the capstan (66,2) and stops the tape. The start-stop magnet (33,1) retains attracted by the current through the bleeder resistor R13. The tape will start moving, even with the start stop push-button released (stop position). If the operating lever (54,1) is engaged in normal forward drive position before the main switch is turned on. The capacitor C7 has not yet been charged to 350 V and the current through the bleeder resistor R13 is not sufficient to attract the start-stop magnet (33,1). The start-stop magnet will again work properly when the start-stop push-button is operated once.

5.1.10 The power supply

The schematic for the power supply is shown below. Ref. fig. 52.

The mains transformer 11,1-273-1 is equipped with a mains selector for 110-125-145-200-220-245 V and can be used for 50-60 Hz.

Note: Check that the mains selector at the bottom of the tape recorder is set to the correct voltage before the tape recorder is connected to the mains.

The transformer 11,1-273-1 is furnished with a melting fuse (Rose metal) in the primary winding. All

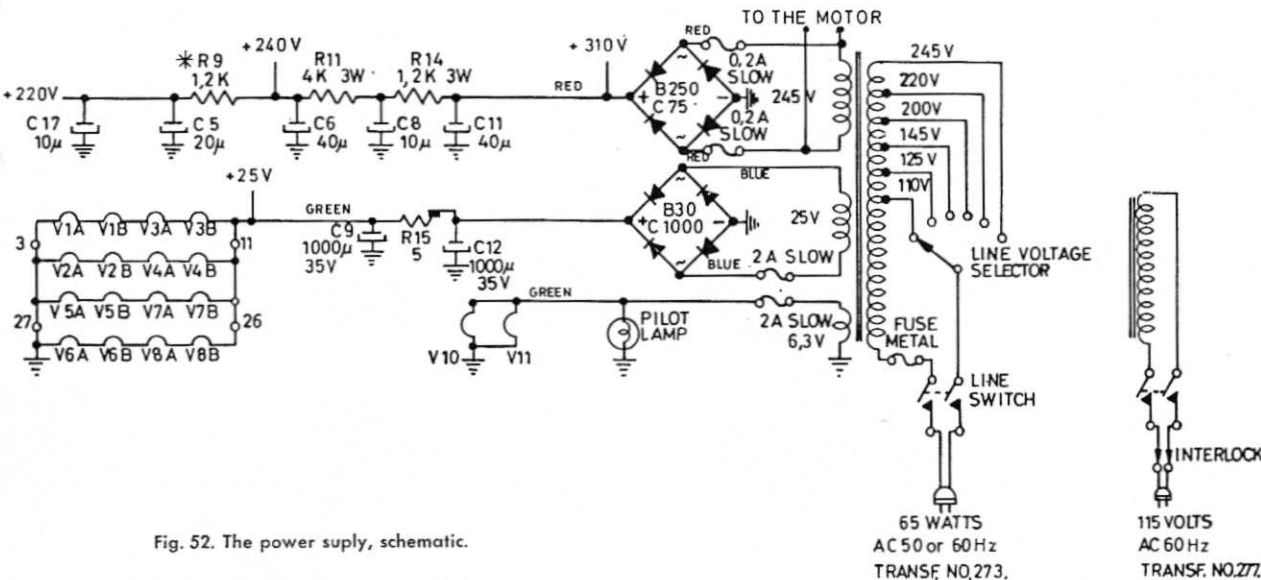

Fig. 52. The power supply, schematic.

secondary windings are fused with slow-blow fuses. The 245 V secondary winding is connected to the bridge rectifier B250-C75 and furnishes all the high tension to the amplifiers, indicators and to the motor. The 25 V secondary winding is connected to the rectifier B30-C1000 and furnishes the line voltage to the oscillator and the center channel amplifier. The rectifier B30-C1000 also furnishes the DC filament

voltage to all amplifier and cathode follower tubes. These tubes are DC heated to prevent hum. The 6.3 V secondary winding furnishes the AC filament voltage to the pilot lamp and the indicator tubes.

Note: The transformer 11,1-277 and the interlock system inserted in the mains cord is furnished on tape recorders sold in certain territories to conform with the UL approval.

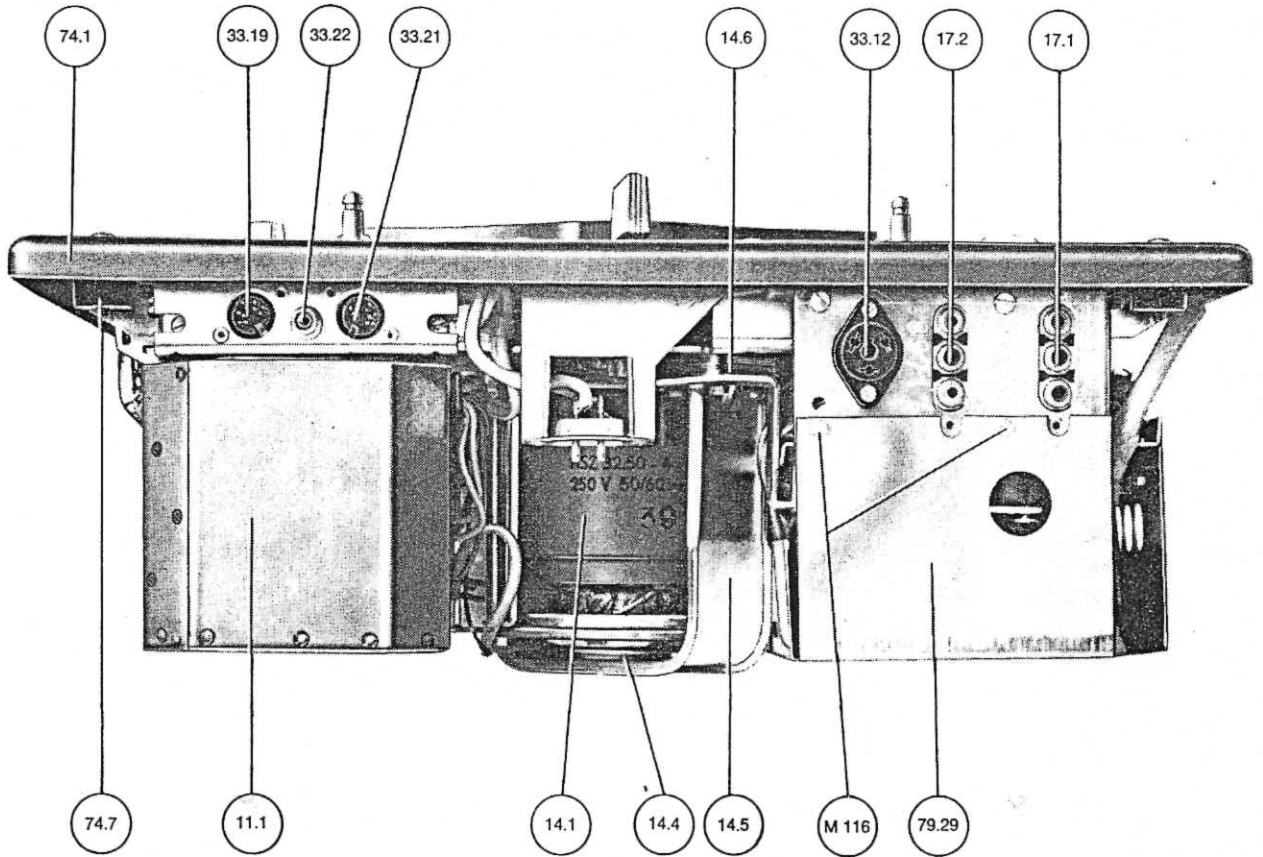

Fig. 53. Rear view of tape recorder equipped with papst motor and transformer 11.1-277-6C.

5.2 THE SWITCHING SYSTEM, BLOCK DIAGRAM

OPEN WHEN THE S-ON-S SWITCH IS IN "NORMAL" POS.
 CLOSED WHEN THE S-ON-S SWITCH IS IN "S-ON-S" POS.
 CLOSED WHEN THE S-ON-S SWITCH IS IN "A-B TEST" POS. AND BOTH IV AND V ARE RELEASED

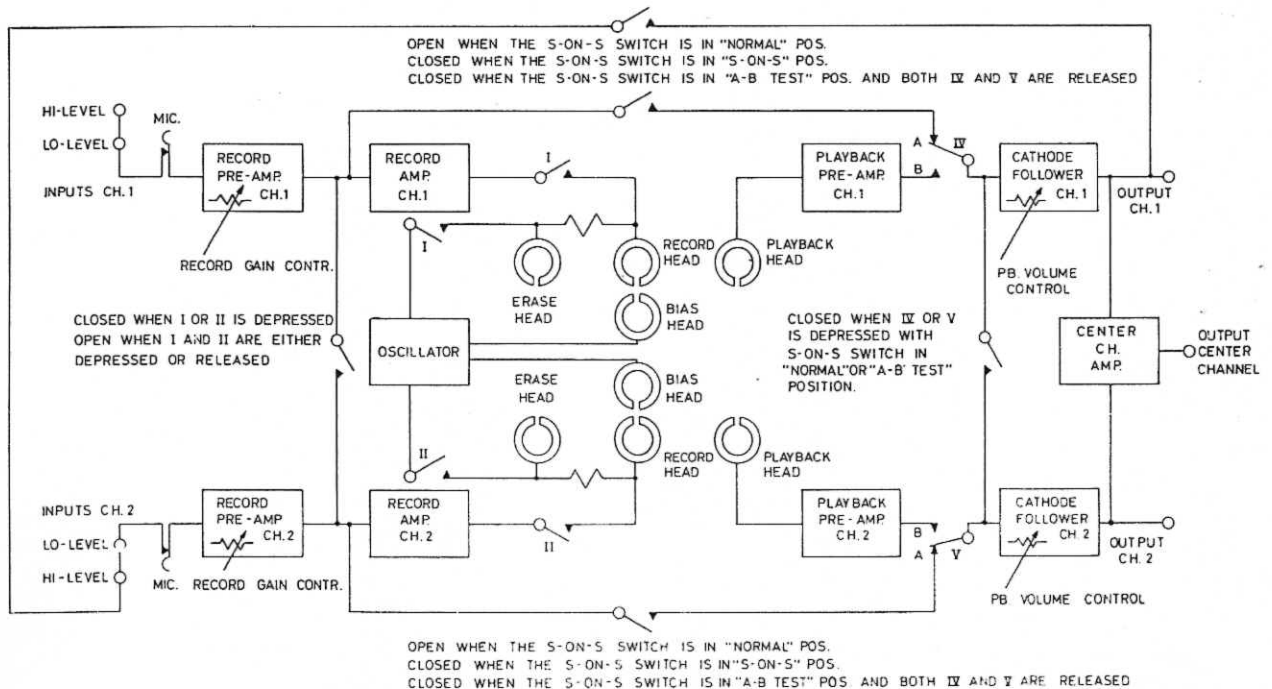

Fig. 54. The switching system, block diagram. All push-buttons released.

6x

5.2.1 The push-button switch

Roman numerals are used as reference to the different push-buttons in the following description. Ref. fig. 55.

- I Record push-button channel 1
- II Record push-button channel 2
- III Start-stop push-button
- IV Playback push-button channel 1
- V Playback push-button channel 2

5.2.2 The S-on-S switch

The S-on-S switch has the following three positions. Ref. fig. 55.

- 1. A-B test
- 2. Normal
- 3. S-on-S

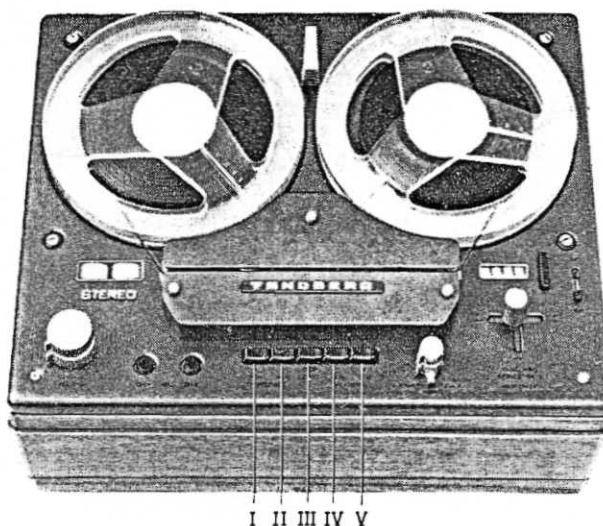

Fig. 55. The push-buttons.

5.2.3 Monaural recording on channel 1 or 2

Ref. block diagram fig. 54.

We presume that we are recording on CH1 (upper track). The input signal is fed to the microphone jack CH1 and the push-button I is depressed. The S-on-S switch is in position A-B test, and the push-button IV is released.

The signal passes through the record pre-amplifier CH1 and the record amplifier CH1 to the record head. The erase head CH1 is activated.

The input of the cathode follower CH1 is connected to the output from the record pre-amplifier CH1 through the push-button IV. We are monitoring the input signal before it is recorded on the tape (A-test).

The signal from the record pre-amplifier CH1 is also connected to the input of the cathode follower CH2 through the push-button V. We are monitoring the input signal from the output of the record pre-amplifier CH1 through both cathode followers in A-test when the push-buttons IV and V are released.

The input signal can be monitored through the cathode follower CH1 in B-test (push button IV depressed) and through the cathode follower CH2 in A-test (push-button V released). The delay between the two reproduced signal is caused by the mechanical distance between the record and playback heads. This delay is used to introduce the echo effects described in chapter 5.2.11.

5.2.4 Mixing during monaural recording

Ref. block diagram fig. 54.

We presume that the mixed programme (programme 1 and 2) is to be recorded on CH1 (upper track). Programme 1 is connected to the high level input CH1 and programme 2 is connected to the high level input CH2.

The outputs from the two record pre-amplifiers are connected together when the push-button I (or II) is depressed. The two programmes are mixed and fed to the record amplifier and the record head CH1. The record levels are controlled separately for the two programmes by the record gain controls.

Four programmes might be mixed together on one channel during monaural recording by feeding different programmes into both high level and low level (FM-MX) inputs on the record pre-amplifiers CH1 and CH2. The record levels of the two programmes connected to the same pre-amplifier cannot be adjusted separately.

Note: The high level and the low level (FM-MX) inputs are disconnected when the microphone plug is inserted.

5.2.5 Stereo recording

Ref. block diagram fig. 54.

The two signals pass through each record pre-amplifier and record amplifier to the record heads. The connection between the two record pre-amplifier outputs is disconnected when the push-buttons I and II are depressed.

The signals from the outputs of the record pre-amplifiers are connected to the inputs of the cathode followers through the push-button IV and V. We are monitoring the input signals from the output of each record pre-amplifier (A-test).

The inputs of the cathode followers will be connected to the outputs of the playback pre-amplifiers by depressing the push-buttons IV and V. We are monitoring the recorded signals from the tape (B-test).

5.2.6 Mixing during stereo recording

Ref. block diagram fig. 54.

Two programmes might be mixed together on each channel during stereo recording by feeding programme 1 to the high level input and programme 2 to the low level (FM-MX) input simultaneously. The record level of the two programmes connected to the same pre-amplifier input cannot be adjusted separately.

Note: The high level and the low level (FM-MX) inputs are disconnected when the microphone plug is inserted.

5.2.7 Monaural playback channel 1 or 2

Ref. block diagram fig. 54.

We presume that the recorded programme is played back from channel 1. The output from the playback pre-amplifier CH1 is connected to the input of the cathode follower CH1 through the push-button IV. The inputs of the two cathode followers are connected together. The programme will be reproduced through both outputs.

5.2.8 Stereo playback

Ref. block diagram fig. 54.

The playback push-buttons IV and V are depressed. The signals will pass each playback pre-amplifier and be fed to the inputs of the two cathode followers. The interconnection between the inputs of the cathode followers is disconnected.

5.2.9 Add a track

Ref. block diagram fig. 54.

The "add a track" recording is a technique of playing back a pre-recorded programme from one channel, and record another programme on the other channel at the same time. Both programmes will be heard simultaneously when the tape is played back in stereo.

We presume that the pre-recorded programme is recorded on channel 1. The push-button IV is depressed and the programme is reproduced through the cathode follower CH1.

The recording is made on CH2 and the push-button II is depressed. The sound on sound switch is set to position S-on-S. The signal passes through the record pre-amplifier CH2 and the record amplifier to the record head CH2. The signal is fed from the output of the preamplifier CH2 to the cathode follower CH2 through the push-button V (A-test).

The input of the cathode follower CH2 is connected to the output of the playback pre-amplifier CH2 by depressing the push-button V. The signal is monitored from the tape (B-test) and reproduced through the cathode follower CH2.

A delay of 150 ms. for the 7 $\frac{1}{2}$ i.p.s. tape speed is introduced between the two programmes, caused by the mechanical distance between the record and playback heads.

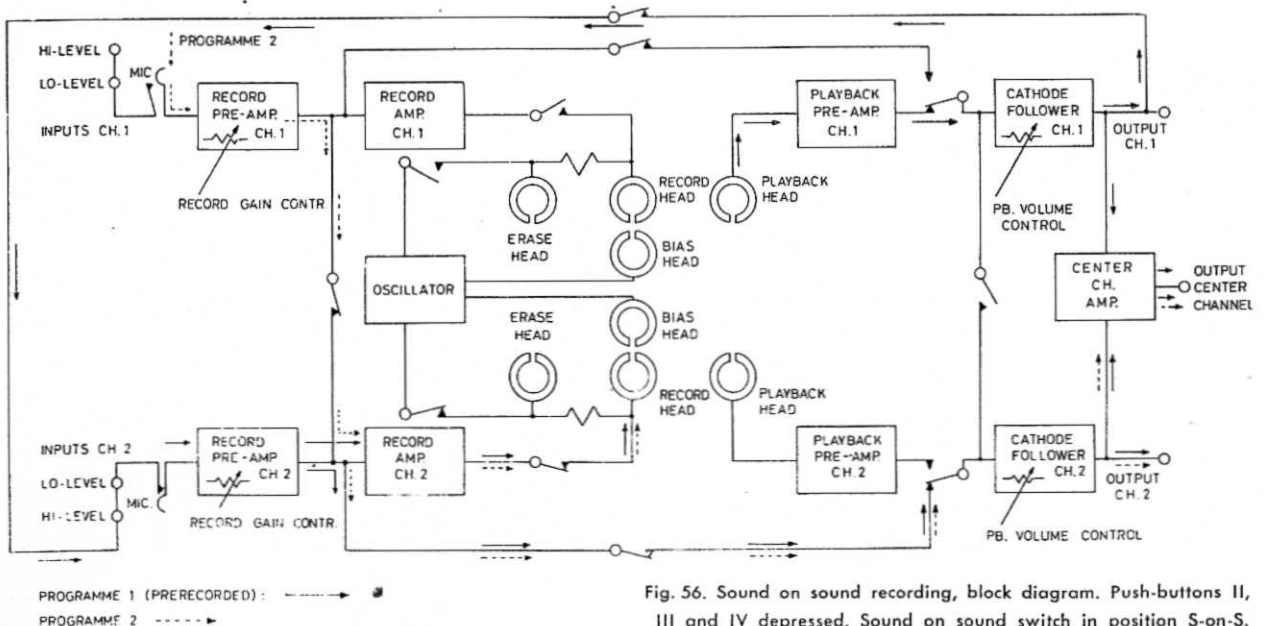

Fig. 56. Sound on sound recording, block diagram. Push-buttons II, III and IV depressed. Sound on sound switch in position S-on-S.

5.2.10 Sound-on sound

Ref. block diagram fig. 56.

The sound on sound recording is at technique of adding sound on to an already existing recording. We presume that the existing programme is recorded on channel 1. This programme is played back and transferred to channel 2 where it is recorded and superimposed by the additional sound. The result is a recording of two programmes combined on one track. The programme is played back as a monaural recording. Programmes may be built up in sequence by adding new instruments or voices as required.

Preferred instructions for sound on sound recordings A-test

The output from CH1 is automatically connected to the high level input on CH2 when the sound on sound switch is set to position MIC. CH1 S on S, and either the push-buttons IV or V are released. The microphone is plugged into the MIC CH1 connector, and the upper playback control is set to position 6. The recording level of the played back programme from CH1 (prerecorded) is adjusted by the lower record gain control knob while the upper knob controls the microphone programme. The total recording level is indicated on the right electronic beam indicator (CH2).

The prerecorded programme on CH1 is supposed to be played back and the push-button IV is depressed. The prerecorded programme on CH1 is fed to the playback pre-amplifier CH1 via the cathode follower CH1 and to the high level input CH2. The two outputs from the record pre-amplifiers are interconnected and the two programmes are mixed and fed via the record amplifier CH2 to the record head CH2. Depress push-button II and hold while moving the operating lever to position normal forward drive. Start the tape recorder by depressing the push-button III. The two programmes are now mixed and recorded on CH2.

Mono headphones can be connected to the cathode follower output CH2 or the center channel output for monitoring (A-test).

When the recording is finished, rewind the tape and play the tape back by depressing the push-buttons III and V and move the operating lever to position normal forward drive. The resulting programme will be reproduced from CH2.

Instead of recording the new programme via microphones this programme can be fed through the high level or low level inputs for CH1. Further programmes can be added by the opposite operation. The prerecorded programmes are now played back from CH2 and recorded on CH1 together with a new programme. The microphone shall still be connected to MIC. CH1 input. The sound on sound switch is set to position MIC. CH1 S on S. The push-buttons I, III and V should be depressed while the operating lever is moved to position normal forward drive.

The level of the programme from CH2 is adjusted by the lower knob of the record gain control, while the level of the microphone programme is adjusted by the upper knob. Both record gain controls will influence on the total record level. The original pre-

recorded programme on CH1 will be erased during this recording.

B-test

The instructions given for sound on sound recording in A-test are valid for sound on sound recording in B-test with the following addition:

An external strap must be connected from the cathode follower output of the channel which is playing back the prerecorded programme to the high level input CH2. The push-buttons II, III, IV and V are depressed and the operating lever is set to position normal forward drive. The programmes are now reproduced in B-test.

Set the upper playback volume control knob (CH1) to position 6 and adjust the listening level from the cathode follower (B-test) with the lower knob.

If the new programme is added with a microphone the echo effect in B-test can be uncomfortable. Consequently it will only be practical to use the B-test during sound on sound recording when the added programme is fed from an external source, and when synchronism between the programmes is not necessary.

5.2.11 Echo effects

Ref. block diagram fig. 54.

A limited possibility of echo effect is obtainable during monaural recording. We presume that the recording is to take place on CH1 (upper track). External amplifiers with loudspeakers, eventually headphones should be connected to both cathode follower outputs, or to the center channel output. The sound on sound switch is set to position MIC. CH1 S on S and both playback volume controls are turned to position 6. The microphone is plugged into the MIC. CH1 connector. Instead of recording the programme via a microphone the programme can be fed into the high level or low level input CH1.

Depress the push-buttons I, III and IV and move the operating lever to position normal forward drive.

The signal passes through the record pre-amplifier CH1 and the record amplifier CH1 to the record head. The output from the playback pre-amplifier CH1 is connected to the input of the cathode follower CH1 through the push-button IV.

The recorded signal from the tape through CH1 is monitored in B-test.

The output from the record pre-amplifier CH1 is connected to the input of the cathode follower CH2 through the push-button V. The input signal through CH2 is monitored in A-test.

The programme is reproduced as an A-test through CH2 and as a B-test through CH1.

The output levels can be adjusted by the playback volume controls.

The delay between the two reproduced signals is determined by the mechanical location of the separate record- and playback heads and by the tape speed. Minimum obtainable delay is 150 msec at 7 $\frac{1}{2}$ i.p.s. tape speed. The echo effect is only present during the actual recording and will not be recorded on the tape.

6x
A recorded echo effect is obtained by the instructions as outlined above.

The delayed B-test signal from the output of the cathode follower CH1 is fed through the record pre-amplifier CH2 to the input of the record amplifier CH1 and mixed with the input signal. Both signals are recorded on CH1. The degree of echo effect is adjusted by the record gain control CH1.

5.3 ALIGNMENT

It is important that the contact between the tape and the heads on the tape recorder is good. To obtain this contact the tape should be run through the tape recorder 5–10 times at normal speed to have the tape polished before measuring the frequency response and the signal to noise ratio.

5.3.1 Demagnetizing

Demagnetize the heads and adjacent parts before aligning the heads.

5.3.2 The mounting plate for the heads

The height of the mounting plate for the heads (15,4) is aligned by the adjustment screw behind the playback head. Move the operating lever slowly to normal forward drive with a tight tape inserted. Align the height of the mounting plate for the heads until the tape runs equidistant from the flanges of the tape guide (79,2). Ref. fig. 11.

5.3.3 The adjustable tape guide

Set the operating lever in normal forward drive with tape inserted and depress the push-button III. Align the adjustable tape guide (79,3) until the tape runs equidistant from the flanges of the adjustable tape guide. Repeat 5.3.2.

5.4 THE PLAYBACK HEAD

Set the tape recorder to position stereo playback. Connect one V.T.V.M. to each CATHODE FOLLOWER output.

5.4.1 Height alignment

Play back the test tape No. 1. This is a full track pre-recorded tape with 1.000 Hz recorded at 7 $\frac{1}{2}$ i.p.s. tape speed. The record level of the exact area corresponding to track 3 is reduced 30 dB. Adjust the height of the playback head until minimum output is obtained on a V.T.V.M. from track 3 (CH2).

5.4.2 Azimuth alignment

Play back the test tape No. 2. This is a full track pre-recorded tape with 10.000 Hz at 7 $\frac{1}{2}$ i.p.s. tape speed. Adjust the azimuth position of the playback head until maximum reading is obtained on both output meters.

5.4.3 Lateral alignment

Check the lateral position of the playback head by pulling the pressure pad (59,5) away from the erase head when the test tape No. 2 is played back. The output level should not decrease more than 3 dB. Adjust the lateral position of the playback head, if

necessary, by turning the head fixing plate. Readjust the azimuth position.

5.5 ADJUSTMENT AND CONTROL OF PLAYBACK AMPLIFIERS, WITH TANDBERG TEST TAPES

5.5.1 Adjustment of the playback amplifiers

Play back the test tape No. 4 with the output volume controls to maximum. This is a full track pre-recorded tape with 400 Hz at 7 $\frac{1}{2}$ i.p.s. tape speed. Adjust the potentiometers R233 (CH1) and R234 (CH2) until the reading on the output meters are 1,3 V.

5.5.2 Control of the playback amplifier

Play back the test tape No. 3. This is a full track pre-recorded tape with the following frequencies: 250–10.000–5.000–1.000–100–50–250 Hz recorded at 7 $\frac{1}{2}$ i.p.s. tape speed. The tape conforms with the N.A.B. standards. The output tolerance is ± 2 dB for all frequencies. The difference in level between the two channels should be less than 3 dB.

5.6 ADJUSTMENT OF THE OSCILLATOR AND BIAS HEAD CIRCUITS

Insert one 10 ohms resistor in series with each bias head half to ground and connect a V.T.V.M. across each resistor.

R609 and R612 is turned up to 1 o'clock position while R607 and R610 are set to approx. 11 o'clock. Set the tape recorder to stereo recording and the speed selector to 7 $\frac{1}{2}$ i.p.s.

Use a calibrated long wave receiver, frequency meter or frequency counter for the indication and adjust the oscillator frequency by C610 until $f/\text{osc.} = 85,5$ kHz.

Set the tape recorder for mono recording CH1 and the speed selector to 7 $\frac{1}{2}$ i.p.s.

Adjust the oscillator frequency by L601 until the frequency is 85,5 kHz.

Set the tape recorder for mono recording CH2.

Readjust L601 to compromise if necessary. The oscillator frequency deviation between mono recording CH1, CH2 and stereo should be less than 2 kHz. The deviation should be indicated with frequency meter, long wave receiver or frequency counter.

Adjust C602 and C604 to maximum reading on the V.T.V.M. Adjust R609 and R612 to 250 mV deflection on the V.T.V.M. (500 mV on the two-track version). Adjust R607 and R610 until 200 mV is obtained on the V.T.V.M. (400 mV on the two track version) with the speed selector in position 17 $\frac{1}{8}$ i.p.s.

When changing the erase head the oscillator frequency may have changed and a frequency indicator should be used. Set the tape recorder to stereo recording and the speed selector to 7 $\frac{1}{2}$ i.p.s. tape speed. Adjust C610 until the frequency is 85,5 kHz. Set the tape recorder to mono recording (CH1 and CH2). Adjust L601 until the oscillator frequency is 85,5 kHz, or more simplified, connect a V.T.V.M. across a 10 ohms resistor in series with the bias head and adjust C610 in stereo recording and L601 in mono recording to maximum deflection on the V.T.V.M.

5.7 THE RECORD HEAD

Adjust the horizontal position of the bias head until the head is in center of the record head. Adjust the height of the bias head until the tapes runs freely in the groove in front of the bias head.

5.7.1 Height alignment

The record head is set in a preliminary position where approx. 0,1 mm (0,0025") of the lamination for the upper track is visible above the tape. The position of the record head can be inspected by using the iron powder method (Magna-See). Record all four tracks on the tape and dip the tape in the solution. The pattern on the tape will show if the position of the head is correct. Readjust if necessary.

5.7.2 Azimuth alignment

Connect a signal generator to the HI-LEVEL inputs CH1 and CH2, and two V.T.V.M. to the CATHODE FOLLOWER outputs CH1 and CH2. Adjust the output level of the signal generator to 500 mV.

Make a stereo recording in B-test at 7 1/2 i.p.s. of a 15.000 Hz signal. Adjust the azimuth of the record head to maximum reading on the output meters. The output level should now be approx. 100 mV with the playback volume controls to maximum, readjust the record gain controls until this is obtained and check the azimuth position of the record head.

5.7.3 Lateral alignment

Check the lateral position of the record head by pulling the pressure pad (59,5) away from the erase head during the recording. The output level should not decrease more than 3 dB. Adjust the lateral position of the record head, if necessary, by turning the head mounting plate. Recheck the height and azimuth position of the head. Ref. para 5.7.1 and 5.7.2.

5.8 THE BIAS HEAD

5.8.1 Height alignment

Connect two V.T.V.M. directly across the recording heads. Set the tape recorder to stereo recording at 7 1/2 i.p.s. and turn both playback volume controls down to zero.

Adjust the height of the bias head by the height adjustment screw (ref. fig. 11) until maximum reading is obtained on both V.T.V.M. Check that the tape runs freely in the groove in front of the bias head and that there is sufficient clearance between the bias head and the mounting plate for the record head. The height position of the bias head is not critical, and if the clearance between the bias head and the mounting plate for the record head is insufficient, raise the bias head slightly.

5.8.2 Horizontal alignment

Connect a V.T.V.M. to each CATHODE FOLLOWER output, and connect a signal generator to the HI-LEVEL inputs CH1 and CH2. Set the tape recorder to stereo recording at 7 1/2 i.p.s. and turn both playback volume controls to maximum.

Record a 1.000 Hz signal, with the output level of the signal generator set to 500 mV.

Untighten the fixing screw for horizontal adjustment (ref. fig. 11) and move the bias head from the extreme left position towards the recording head until maximum reading is obtained on both V.T.V.M. The output level should now be approx. 500 mV, readjust the record gain controls until this is obtained and check the horizontal position of the bias head. After one has assured that the horizontal position is correctly adjusted, tighten the adjustment screw making sure that the head is not being moved. This is eventually indicated by a loss of the output level.

A fine-adjustment of the bias current is obtained by the potentiometers R609 (CH1) and R612 (CH2). Adjust R609 and R612 until maximum reading on the output meters are obtained.

5.9 THE ERASE HEAD

5.9.1 Height alignment

The erase head is set in a preliminary position where approx. 0,25 mm (0.01") of the ferrite core for the upper track of the erase head is visible above the tape. Insert the test tape No. 9 and record a 1.000 Hz signal from the generator on CH2 at optimum recording level. Dip the tape in the Magna-See solution and check that the re-recorded track lies in center of the erase track. Make sure that the erase head does not erase any part of the adjacent tracks.

5.9.2 Azimuth alignment

Align the azimuth position of the erase head by the azimuth adjustment screw. The erase head should be parallel with the mounting plate for the heads (15,4). The azimuth position of the erase head is not critical.

5.9.3 Lateral alignment

Turn the head mounting plate for the erase head, until the front of the head is parallel to the pressure pad.

5.9.4 Model 62x

All the alignments specified in paras 5.4, 5.7, 5.8 and 5.9 are valid for model 62x with the exception of paragraph 5.4.1 which is superseded by 5.11.2 and paragraph 5.7.1 which is superseded by 5.16.2.

5.10 ADJUSTMENT OF THE RECORD CURRENT (A-B test) AND THE ELECTRONIC BEAM INDICATORS

Make sure that all adjustments under paras 5.3, 5.4 and 5.6 are made before proceeding with these adjustments.

Connect a signal generator to both HI-LEVEL inputs and connect two V.T.V.M. to the CATHODE FOLLOWER outputs.

Record a 400 Hz signal in stereo A-test, with both playback volume controls to maximum at 7 1/2 i.p.s. Adjust the record levels by the record gain controls until the output levels are 1,5 V. Depress the push-buttons IV and V (stereo B-test) and adjust the record current by R115 (CH1) and R116 (CH2) until the readings on the output meters are 1,5 V.

Adjust R137 (CH1) and R138 (CH2) until the electronic beam indicators are closing. Release the push-buttons IV and V (stereo A-test) and check that the readings still are 1,5 V on the output meters.

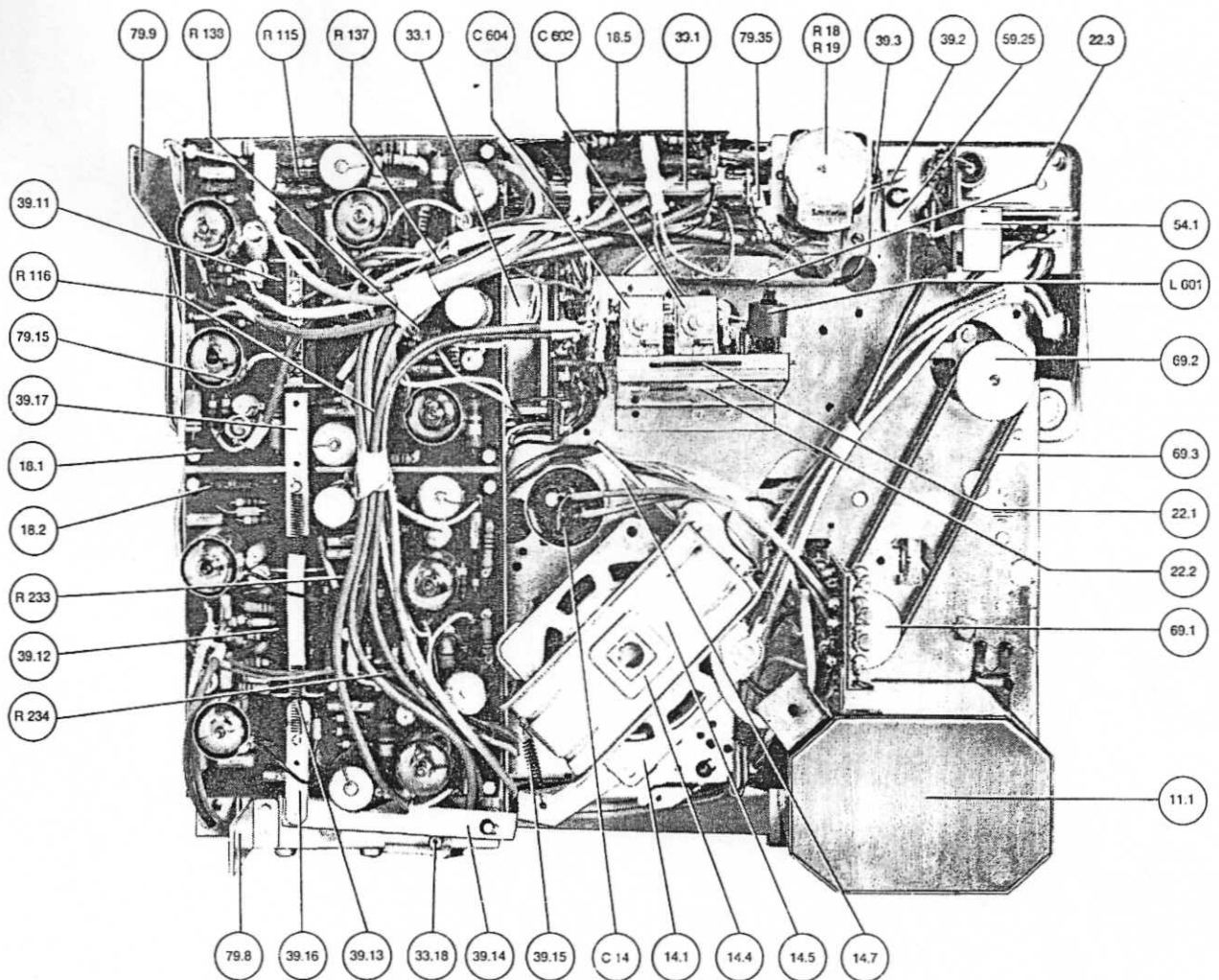

Fig. 57. Bottom view of the tape recorder.

5.11 HEAD ALIGNMENT WITHOUT TANDBERG TEST TAPES

5.11.1 The playback head

5.11.2 Height alignment

The height of the playback head is aligned by the height adjustment screws. The upper edge of the tape shall run flush with the upper part of the airgap for channel 1.

5.11.3 Azimuth alignment

Play back a standard azimuth alignment tape with a V.T.V.M. connected to each cathode follower output. Adjust the position of the playback head by the azimuth adjustment screw, until maximum reading is obtained on the output meters.

5.11.4 Lateral alignment

Pull the pressure pad (59,5) away from the erase head when the standard azimuth alignment tape is being played back. The output level should not decrease more than 3 dB. Adjust the lateral position of the playback head, if necessary, by turning the head mounting plate.

5.12 THE RECORD HEAD

Follow the instruction given under para 5.7.

5.13 THE BIAS HEAD

Follow the instruction given under para 5.8.

5.14 THE ERASE HEAD

5.14.1 Height alignment

The height of the erase head is aligned by the height adjustment screws. Approx. 0,25 mm (.01") of the ferrite core for the upper track of the erase head should be visible above the tape.

5.14.2 Azimuth alignment

Align the azimuth position of the erase head by the azimuth adjustment screw. The erase should be parallel with the mounting plate for the heads (15,4). The azimuth position of the erase head is not critical.

5.14.3 Lateral alignment

Turn the head mounting plate for the erase head, until the front of the head is parallel to the pressure pad.

5.15 TRACK CONTROL, MODEL 64x

5.15.1 The record head

Record a 1.000 Hz signal from a generator at optimum recording level in stereo A-test on track 1 and 3 (push-buttons I, II and III depressed) for approx 5

seconds. Turn the tape around and make a similar recording on track 4 and 2. Cut the tape and dip it into a mixture of iron powder and alcohol (Magna-See) to make the recording visible. The spaces between the recorded tracks should be distributed equidistant across the tape. Readjust the height position, if necessary, and recheck the azimuth alignment.

5.15.2 The erase head

Insert a full-track pre-recorded tape and record a 1.000 Hz signal from a generator at optimum recording level in mono A-test on track 3 (push-buttons II and III depressed). Cut the tape and dip it in the Magna-See solution. Check that the re-recorded track is in the center of the erase area. Adjust the vertical position of the erase head if necessary.

5.15.3 The playback head

Record a 1.000 Hz signal on track 1 (CH1) and a 500 Hz signal on track 3 (CH2) at optimum recording levels. Turn the tape around and play back track 2 (push-buttons III and V depressed) at maximum volume. No signal should be heard. Raise the playback head if the 1.000 Hz signal is heard. Lower the playback head if the 500 Hz signal is heard. Re-check the azimuth position.

5.16 TRACK CONTROL, MODEL 62x

5.16.1 The erase head

The height of the erase head is aligned by the height adjustment screws. The tape shall run equidistant from the upper and the lower edge of the ferrite core.

5.16.2 The record head

The height of the record head is aligned by the height adjustment screws. Record a 1.000 Hz signal in stereo (push-buttons I, II and III depressed) at optimum recording level on a full-track pre-recorded tape. Dip the tape in the Magna-See solution and check that the tracks are distributed symmetrically across the tape, and that the recorded zone remains in the center of the erase zone. Re-adjust the erase and the record heads, if necessary.

5.16.3 The playback head

The height of the playback head is aligned by the height adjustment screws. The tape shall run flush with the upper edge of the lamination for channel 1. Re-adjust the azimuth if necessary.

5.17 ADJUSTMENTS OF THE AMPLIFIERS, WITHOUT TANDBERG TEST TAPES

A V.T.V.M. is connected to each output terminal. The signal generator is connected to the high level inputs of both channels and tuned to 400 Hz.

The tape recorder is set up for stereo recording A-test (push-buttons, I, II and III depressed with the operating lever in position normal forward drive) at $7\frac{1}{2}$ i.p.s. tape speed. Insert a good quality recording tape.

Adjust the recording gain controls until the readings

on the output meters are 1,5 V with the playback controls to maximum.

Replace the V.T.V.M. for channel 1 with a distortion meter and depress the push-button IV (B-test CH1). Adjust the recording current by R115 until the reading shows 3% distortion.

Replace the V.T.V.M. for channel 2 with the distortion meter and depress the push-button V (B-test CH2). Adjust the recorder current by R116 until the reading shows 3% distortion.

Adjust R137 (CH1) and R138 (CH2) until the electronic beam indicators are closing.

Connect a V.T.V.M. to each output terminal and proceed the recording as described above in stereo B-test with all push-buttons depressed.

Adjust R233 (CH1) and R234 (CH2) until the reading on the output meters are 1,5 V. Make sure that the playback volume controls are set to maximum. Release the push-buttons IV and V (stereo A-test) and check that the reading on the output meters still are 1,5 V.

5.18 CONTROL OF TOTAL FREQUENCY RESPONSE

The tape recorder is set up for stereo recording B-test (all push-buttons depressed) at $7\frac{1}{2}$ i.p.s. tape speed, and with a good quality recording tape inserted. (Scotch 150 which should be run 5–10 times before use to have the tape surface polished.)

A V.T.V.M. is connected to each output terminal. The signal generator is connected to the HI-level inputs of both channels. Tune the generator to 400 Hz and set the output level from the generator 25 dB below optimum recording level. The readings on the output meters are the 0 dB reference points. If the oscillator voltage for the two track version is 25–28 dB below optimal recording level, a simple serial resonant circuit has to be connected across the V.T.V.M. to prevent eventual error of the measurements. The filter circuit is tuned to 85,5 kHz. Check the frequency response for all speeds according to the specification. Ref. fig. 58.

$7\frac{1}{2}$ i.p.s.: 20–25.000 Hz (± 2 dB 40–18.000 Hz)

$3\frac{3}{4}$ i.p.s.: 20–18.000 Hz (± 2 dB 40–14.000 Hz)

$1\frac{7}{8}$ i.p.s.: 30–12.000 Hz (± 2 dB 40– 8.000 Hz)

The difference in level between the two channels should be less than 3 dB at any frequency.

Increase the bias slightly if the treble response is too high. Adjust R609 (CH1) and R612 (CH2) for $7\frac{1}{2}$ i.p.s. and $3\frac{3}{4}$ i.p.s. Adjust R607 (CH1) and R610 (CH2) for $1\frac{7}{8}$ i.p.s. until correct frequency response is obtained.

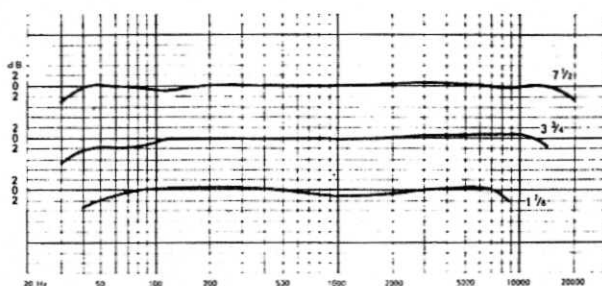

Fig. 58. The total frequency response.

5.19 CONTROL OF PLAYBACK AND RECORD AMPLIFIERS

If the frequency response does not stand up to the tolerances given above, one should check the playback and record amplifiers.

5.19.1 The playback amplifier

Insert a 100 ohm resistor in series with the playback head for the upper track (CH1) to ground (red wire). Connect a V.T.V.M. to the cathode follower outputs CH1 (CH2). Connect a signal generator in series with a 10 kohms resistor to the top of the 100 ohms resistor. Depress the push-button IV (monaural playback CH1) and set the operating lever to normal forward drive with the playback volume control to maximum. The signal generator is tuned to 400 Hz with an output level of 100 mV. The reading on the output meter is the 0 dB reference point, at $7\frac{1}{2}$ i.p.s. tape speed. Check the frequency response according to fig. 46. Repeat the measurements for the lower track (CH2). The output tolerance is ± 2 dB for all frequencies. The difference in level between the two channels should be maximum 3 dB at any frequency.

5.19.2 The record amplifier

Insert a 1.000 ohms resistor in series with the record head for upper track (CH1) to ground (black wire). Connect a V.T.V.M. across the resistor. The signal generator is connected to the HI-level input of CH1. Depress the push-button I (monaural recording CH1) and set the operating lever to normal forward drive. Tune the signal generator to 400 Hz and set the output from the generator 25 dB below optimum recording level. The reading on the output meter is the 0 dB reference point. Check the frequency response according to fig. 44. Repeat the measurements for the lower track (CH2). The output tolerance is ± 2 dB for all frequencies. The difference in level between the two channels should be less than 3 dB at any frequency.

5.20 ADJUSTMENT OF THE FM-MULTIPLEX FILTER

Feed a 19.000 Hz signal to both FM-MX inputs and depress the push-buttons I and II. Set the S-on-S switch to A-B test and the playback volume controls to maximum. The recording gain controls should be set to optimum recording level. Connect a V.T.V.M. to each cathode follower output. Adjust the core of L4 (CH1) and L5 (CH2) for minimum reading on the output meters.

The procedure for aligning the $33\frac{1}{3}$ kHz filter is the same as outlined for the 19 kHz filter except for the generator which should be set to 24,25 kHz. Adjust the core of L7 (CH1) and L8 (CH2) to minimum reading on the output meters. The tuning to 24.25 kHz is done to obtain 10 dB attenuation from 23–43 kHz.

5.21 ADJUSTMENT OF THE MICROSWITCHES

The bias is reduced in $1\frac{7}{8}$ i.p.s. tape speed to obtain correct frequency response. The microswitches are introduced in the bias regulating circuits and activate the potentiometers R607 (CH1) and R610 (CH2) in $1\frac{7}{8}$ i.p.s. tape speed only. The microswitches are located at the rear of the tape recorder. Set the speed selector to $1\frac{7}{8}$ i.p.s. and loosen the two screws holding the microswitch bracket. Move the bracket slowly towards the activating arm until the switches operate, and tighten the two screws. Check the adjustment by moving the speed selector knob slowly from $1\frac{7}{8}$ i.p.s. til $3\frac{3}{4}$ i.p.s. and back. The switches shall now operate properly.

5.22 VERTICAL MOUNTING OF THE MODELS 64x AND 62x

Ref. fig. 59.

The models 64x and 62x can be mounted in vertical position when the thrust spring (66.13) is attached as shown in fig. 59.

The tape reels must be locked in position by the holders (65.4) to prevent the reels from falling off turntables.

Mounting:

Unscrew the screw A and insert the thrust spring (66.13). The delrin knob shall rest on top of the capstan. Tighten screw A. The tension of the spring should be sufficient to prevent any axial movement of the capstan.

Note: The utmost care must be taken during the mounting of the thrust spring, and the screw B should not be touched, to prevent misalignment of the capstan.

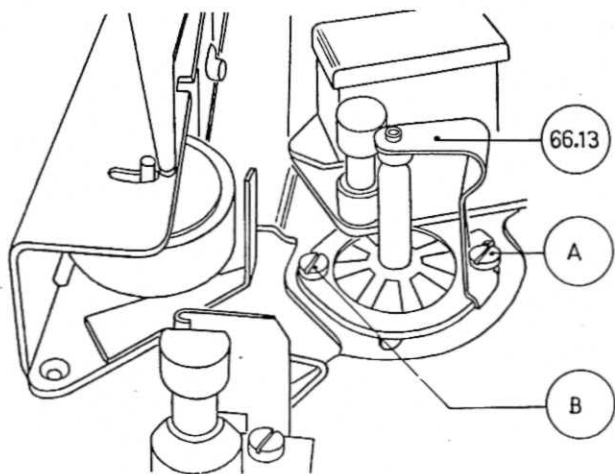

Fig. 59. Mounting of thrust spring 66.13.

6x
5.23 MODIFICATION FROM MODEL 64x TO MODEL 62x

The following changes have to be introduced when

the tape recorder is modified from four-track to two-track.

PART	MODEL 64x	MODEL 62x
R235	51 kohms	33 kohms
R236	51 kohms	33 kohms
R601	20 kohms	39 kohms
R602	2 kohms	3,9 kohms
R603	20 kohms	39 kohms
R604	20 kohms	39 kohms
R605	2 kohms	3,9 kohms
R606	20 kohms	39 kohms
C117	.015 μF	.01 μF
C118	.015 μF	.01 μF
C601	500 pF	2000 pF
C603	500 pF	2000 pF
C611	300 pF	820 pF
Erase head	41H	48H
Bias head	42H	52H
Record head	55H (44H)	57H
Playback head	56H (45H)	58H
Q601	2N3705	TIS60M } *
Q602	2N3702	TIS61M } *
Q603	2N3705	TIS60M } *
Q604	2N3702	TIS61M } *

* Matched pair.
 If the transistors 2N3705 and 2N3702 are used, they

should be replaced by TIS60M and TIS61M, matched pairs.

6.0 Parts list

To improve the equipment minor changes and modifications have been introduced on models 64x and 62x. The complete reference number of the part and the serial number of the tape recorder must therefore be specified when spare parts are ordered.

The code for the part reference number:

66.1 - 1 - 6C - * - Flywheel, complete
 1 2 3 4

1) The three or four first numbers state the part and are referred to in all figures.

2) This digit is presented only when modification is introduced to the part. In some cases this number also refers to sub contractors specifications.

3) The type number states the type of tape recorder for which the part is used, i.e.:
 64x - Parts only for model 64x
 62x - Parts only for model 62x
 6C - The part is interchangeable and are used for the models 64x and 62x.

4) Modified parts indicated with * may be used as replacement for parts of earlier design.

6.0.1 Mechanical parts

Ref. No.	Description	Fig. ref.	Notes
11.1-273-1-6C	Power transformer 110—245 V	53, 57	
11.1-277-6C	Power transformer 115 V, 60 Hz	53, 57	
11.3-6C	Bracket for interlock, complete (115 V, 60 Hz)		
13.1-6C	Oscillator transformer, T601		
14.1-780De-6C	Motor, Papst 780De w/boss	31, 53, 57	
14.1-780DeZ-6C	Motor, Papst 780DeZ w/boss	31, 53, 57	Introduced from serial No. 689910 Removed from serial No. 689910
14.2-780De-6C	Bracket for mounting of motor		
14.4-6C	Shock absorber for motor, 780De	31, 53, 57	
14.4-1-6C	Shock absorber for motor, 780DeZ	31, 53, 57	Introduced from serial No. 689910
14.5-6C	Bridge for mounting of motor	53, 57	
14.6-1-6C	Plate shim 2,3 mm	53	

Ref. No.	Description	Fig. ref.	Notes
14.6-2-6C	Plate shim 0,7 mm	53	
14.7-6C	Bracket motorcapasitor	5, 7	
17.1-6C	Terminal plate with phono jacks CH1 (green, black and red)	53	
17.2-6C	Terminal plate with phono jacks CH2 (yellow, black and blue)	53	
18.1-2-64X	Record amplifier board, without tubes	57	
18.1-2-62X	Record amplifier board, without tubes	57	
18.2-1-6C	Playback amplifier board, without tubes	57	
18.4-6C	Tube socket (all tubes)		
18.5-1-6C	Center channel amplifier board, with components	57	
19.1-6C	Fuse board		
19.2-6C	Soldering strip, record head	11	
19.3-6C	Soldering strip, playback head	11	
19.4-6C	Soldering strip, erase head	11	
19.5-6C	Soldering strip, bias head	11	
19.6-6C	Soldering strip, for resistors		
22.1-2-6C	Oscillator board, without tubes	57	
22.2-6C	Bracket for oscillator board	57	
22.3-6C	Shield for oscillator board	57	
24.1-1-6C	FM multiplex-filter, 19 kHz		
24.1-2-6C	FM multiplex-filter, 33 $\frac{1}{3}$ kHz		
31.1-6C	Indicator board, without tubes		
31.2-6C	Spring for indicator tubes	6	
31.2-1-6C	Spring for indicator tubes	6	Introduced from serial No. 688142
32.2-3-6C	Knob for record gain control, upper	38	
32.2-4-6C	Knob for record gain control, lower	38	
32.2-5-6C	Knob for record gain control, upper	38	Introduced from serial No. 689801
32.2-6-6C	Knob for record gain control, lower	38	Introduced from serial No. 689801
32.4-3-6C	Knob for playback volume control, upper	38	
32.4-4-6C	Knob for playback volume control, lower	38	
32.4-5-6C	Knob for playback volume control, upper	38	Introduced from serial No. 689801
32.4-6-6C	Knob for playback volume control, lower	38	Introduced from serial No. 689801
32.14-6C	Felt washer for knob		
32.15-6C	Felt washer for switch		
33.1-6C	Start-stop magnet, complete	35, 57, 70	
33.5-6C	Microswitch R x 1 for operating lever	5	
33.6-1-6C	Plate spring microswitch		
33.7-1-6C	Actuator lever, microswitch	7	
33.9-6C	Line switch (ON-OFF)	6	
33.11-6C	Slip-on knob, black		
33.12-6C	3 prong socket, remote control	53	
33.15-6C	Clamp for microswitch		
33.16-6C	Microswitch R x 1 for end stop	9	
33.17-6C	Insulation shield	9	
33.18-6C	Switch for bias head (17/8") with bracket	57	
33.19-6C	5 pin DIN contact (Line)	6, 53	
33.21-6C	5 pin DIN contact (Radio)	6, 53	
33.22-6C	Phono contact, center channel	6, 53	
33.23-6C	Bracket for DIN-contact		
39.1-1-6C	Push button, center	6, 57	
39.1-2-6C	Push button, center	6, 57	
39.2-6C	Arm, record lock	57	
39.3-6C	Spring, record lock-arm	57	Introduced from serial No. 690091

6x

Ref. No.	Description	Fig. ref.	Notes
39.4-1-6C	Sound-on-Sound switch	-	
39.5-1-6C*	Lever for Sound-on-Sound switch	38	
39.6-6C	Muting switch	9	
39.8-6C	Spring, muting switch	9	
39.11-6C	Equalization switch, record amplifier	57	
39.12-6C	Equalization switch, playback amplifier	57	
39.13-6C	Spring, equalization switch	57	
39.14-1-6C	Arm, equalization switch	57	
39.15-2-6C	Spring, equalization switch arm	57	
39.16-6C	Joint plate, equalization arm	57	
39.17-6C	Joint plate, equalization switch	57	
39.18-6C	Shield for push button switch	57	
44.1-6C	Pilot lamp, 6,3 Volts	9	
44.2-6C	Socket, pilot lamp	9	
44.3-6C	Shield, pilot lamp	6	
45.1-2-6C	Microphone jack, black (J412A)	6	
48.1-2-6C	Wooden case		
48.2-6C	Buffer, polyethylene		
51.1-6C	Pressure wheel	10, 11, 70	
51.2-6C	Shaft for pressure wheel	10, 11, 35, 70	
51.3-1-6C	Pressure wheel bracket, complete	6	
51.4-6C	Spring for pressure wheel	10, 35, 70	
51.5-1-6C	Lever for pressure wheel	10, 11, 35, 70	
51.6-6C	Shaft for pressure wheel lever	11, 35, 70	
51.7-6C	Latch for spring, pressure wheel	10, 11, 35, 70	
51.8-6C	Start-stop lever	11, 12, 35, 70	
51.9-6C	Roller for pressure wheel bracket	9	
51.12-6C	Spring for pressure wheel bracket		
51.12-1-6C	Spring for pressure wheel bracket		Introduced from serial No. 688265
51.13-1-6C	Tape brake assembly, complete	11, 70	
51.15-6C	Brake block for tape brake	11, 70	
51.16-6C	Transfer bracket for bias head	11, 35, 70	
51.17-6C	Spring for bias head	70	
51.18-6C	Spring, bracket bias head	70	
51.19-6C	Bracket, bias head	11, 70	
52.1-1-6C	Trip bar	12, 21, 22, 23, 24, 25, 26, 27, 28, 29, 30	
52.2-6C	Extension spring, lifting arm	6, 12	
53.1-6C	Speed transfer wheel	6, 12, 31, 34	
53.2-2-6C	Transfer wheel holder	12, 34	
53.3-2-6C	Mounting arm for transfer wheel	12, 34	
53.4-1-6C	Knob for speed selector	38	
53.5-2-6C	Spring for transfer wheel holder	12, 31, 34	
53.7-6C	Parallel arm, complete	12, 34	
54.1-2-6C	Operating lever, complete	6, 7, 57	
54.2-1-6C	Operating lever shaft with delrin ball	7	
54.3-1-6C	Knob, operating lever	38	
54.11-6C	Clip for operating lever	7	
59.1-6C	Eccentric segment	9	
59.2-6C	Shaft eccentric segment (stud)		
59.4-6C	Pressure pad arm	11, 35, 70	
59.6-6C	Spring for pressure pad arm	35, 70	
59.7-6C	Upper clutch lever for take-up-friction disc.	12, 16, 17, 22, 24, 26, 28, 30	
59.8-6C	Lower clutch lever for take-up-friction disc.	12, 16, 17, 22, 24, 26, 28, 30	
59.9-6C	Clutch lever for supply friction disc.	12, 13, 14, 21, 23, 25, 27, 29	

42

Ref. No.	Description	Fig. ref.	Notes
59.11-6C	Shaft for 59.7	12, 22, 24, 26, 28, 30, 34	
59.12-6C	Spring for 59.7	22, 24, 26, 28, 30, 34	
59.13-6C	Shaft for 59.8	12, 22, 24, 26, 28, 30, 34	
59.14-6C	Spring for 59.8	22, 24, 26, 28, 30	
59.15-6C	Shaft for 59.9	12, 21, 23, 25, 27, 29	
59.16-6C	Spring for 59.9	21, 23, 25, 27, 29	
59.17-1-6C	Cam disc	34	
59.18-6C	Cam disc arm, complete	12, 34	
59.19-6C	Extension spring for cam disc arm	12, 34	
59.23-6C	Bracket for shaft, cam disc arm	12, 34	
59.24-6C	Shaft for cam disc arm	12	
59.25-1-6C	Transfer wheel lifting arm, complete	6, 12, 34, 57	
59.26-1-6C	Transfer bracket	11, 35, 70	
59.27-6C	Spring with felt for pressure pad	11, 35, 70	
59.28-6C	Brake lever for supply turntable complete	12, 21, 23, 25, 27, 29	
59.29-6C	Shaft for brake lever, supply turntable	12, 21, 23, 25, 27, 29	
59.31-6C	Spring for brake lever, supply turntable	21, 23, 25, 27, 29	
59.32-6C	Delrin button for clutch levers	12, 14, 17, 21, 22, 23, 24, 25, 26, 27, 28, 29, 30	
61.1-2-6C	Take-up friction disc (right)	15, 16, 17, 22, 23, 24, 26, 28, 30, 31	
61.2-1-6C	Supply friction disc (left)	13, 14, 15, 21, 25, 27, 29	
61.3-6C	Helical compression spring, take-up-friction disc	16, 22, 24, 26, 28, 30, 31	
61.4-6C	Helical compression spring, supply friction disc	13, 21, 23, 25, 27, 29, 31	
61.6-1-6C	Mylar sheet for take-up friction disc	16	
61.7-1-6C	Mylar sheet for supply friction disc	13, 15	
61.9-1-6C	Tape tight disc	13	
61.11-6C	Spring for tape tight disc	13, 15	
62.1-5749-6C*	Motor pulley 50 Hz	6, 31, 32, 34	
62.1-5750-6C*	Motor pulley 60 Hz	6, 31	
62.2-6C	Rubber drive belt	6, 31	
65.1-1-6C	Take-up turntable (right)	6, 16, 22, 24, 26, 28, 30, 31	
65.2-1-6C	Supply turntable (left)	6, 13, 21, 22, 25, 27, 29, 31	
65.4-6C	Tape reel holder		
65.5-6C	Delrin nut	13	
66.1-1-6C*	Flywheel, complete	6, 11, 31, 34	
66.3-6C	Self lubricating bearing for flywheel	9, 32	
66.4-6C	Spring for upper flywheel bearing	11, 32	
66.5-6C	Spring for lower flywheel bearing	12, 32	
66.6-6C	Felt ring for flywheel bearing	32	
66.7-6C	Latch for flywheel bearing, threaded	9, 32	
66.8-6C	Latch for flywheel bearing, not threaded	11, 12, 32	
66.9-1-6C	Brake arm with felt	12, 32	
66.12-6C	Thrust washer	32	
66.13-6C	Thrust spring with delrin knob	32, 59	
66.14-6C	Feltring, flywheel	32	
66.15-6C	Bushing, flywheel	32	
66.16-6C	Spring lock, flywheel	32	
66.17-1-6C	Felt, flywheel (adhesive)	32	
69.1-1-6C	Pulley for revolution counter (turntable)	16, 57	
69.2-1-6C	Pulley for revolution counter (counter)	57	
69.3-6C	Rubber belt, revolution counter	5, 57	
72.1-6C	Flange for take-up turntable housing	16	
72.2-6C	Flange for supply turntable housing	13, 15	
73.1-6C	Front trim cover	38	

Ref. No.	Description	Fig. ref.	Notes
73.2-6C	Rear trim cover	38	
73.3-6C	Screw for trim cover	38	
73.4-6C	Bracket for front trim cover, left	38	
73.5-6C	Bracket for front trim cover, right	38	
73.6-6C	Bracket for front trim cover		
73.6-1-6C	Bracket for rear trim cover		Introduced from serial No. 688265
74.1-5-62x	Top cover	53	
74.1-6-64x	Top cover	53	
74.1-7-62x	Top cover 115 V	53	
74.1-8-64x	Top cover 115 V	53	
74.2-6C	Mounting screw (4 x 24 mm)	38	
74.4-6C	Washer for mounting screw	38	
74.5-2-6C	Screw for top cover (3 x 8 mm) Phillips head	38	
74.6-6C	Rubber washer for 74.5	38	
74.7-6C	Lower rubber mounting, rear	38, 53	
74.8-6C	Upper rubber mounting, rear	38	
79.1-6C	Tape guide left	11	
79.2-6C	Tape guide	11	
79.3-6C	Tape guide, adjustable	11, 34	
79.4-6C	Tape guide, right	11, 34	
79.8-6C	Chassis leg, left rear	57	
79.9-6C	Chassis leg, left front	6, 57	
79.11-1-6C	Speed selector bracket	12, 34	
79.13-6C	Spring for speed selector	34	
79.14-1-6C	Revolution counter	6, 9	
79.18-1-6C	Cover plate 1		
79.19-1-6C	Cover plate 2		
79.22-1-6C	Stereo emblem		
79.23-1-6C	Tandberg emblem		
79.24-6C	Window, revolution counter		
79.25-6C	Window, indicator		
79.26-6C	Spring for fuse holder		
79.27-6C	Rubber mounting tube for printed circuit boards		
79.29-6C	Shield, amplifier board	53	
79.31-6C	Bracket for revolution counter	9	
79.32-6C	Actuating spring for end-stop	11	
79.33-6C	Bracket with shaft for actuating spring, end-stop	11 9	
79.34-6C	Bracket terminal	9	
79.35-6C	Release lever, complete	57	

Screws, washers and lock washers

M101	Screw 3 x 4 mm c.h.	M122	Screw 4 x 22 mm c.h.	M317	Lock ring 5 mm
M102	Screw 3 x 4,5 mm c.h.	M125	Screw 3 x 6 mm c.h. 1,5 mm head	M318	Lock ring 6 mm
M104	Screw 3 x 6 mm c.h.	M146	Unbraco screw 3 x 3 mm	M321	Lock ring 4 x 0,6 mm
M107	Screw 3 x 8 mm c.h.	M147	Unbraco screw 3 x 4 mm	M325	Washer 16 x 4,2 x 1,65 mm
M112	Screw 4 x 6 mm c.h.	M301	Turbax washer 7,5 x 4,2 x 0,2 mm	M329	Lock ring 2,3 mm
M113	Screw 4 x 8 mm c.h.	M302	Turbax washer 7,5 x 4,2 x 0,3 mm	M333	Spring washer 1/8"
M114	Screw 4 x 10 mm c.h.	M303	Turbax washer 7,5 x 4,2 x 0,5 mm	M348	Teflon washer 6,5 x 4,2 x 0,2 mm
M116	Parker screw 1/4" No. 4	M313	Lock ring 2,5 mm	M349	Lock washer 4 mm
M121	Screw 2,3 x 12 mm c.h.	M314	Lock ring 3 mm	M358	Lock washer 5 mm
		M315	Lock ring 3,5 mm	M403	Rivet 3,5 mm

6.0.2 Electrical parts

Transistors

Q1-6C	Transistor SE4001	Q603/604-6C	Transistor TIS61M/TIS60M
Q2-6C	Transistor BC115 (SE6001)		(2N3705/2N3702)
Q601/Q602-6C	Transistor TIS61M/TIS60M	Q605-6C1	Transistor U2848/2
	(2N3705/2N3702)	Q606-6C1	Transistor U2848/2

Tubes

V1, V2, V5, V6-6C Tube ECC83 (12AX7)
 V7, V8-6C Tube ECC82 (12AU7)
 V3-1, V4-1-6C Tube ECC81 (12AT7)
 V10, V11-6C Tube EAM86

48H-62x
 52H-62x
 57H-62x
 58H-62x

Erase head
 Bias head
 Record head
 Playback head

Trimming capacitors

C602-6C Trimming capacitor 750 pF
 C604-6C Trimming capacitor 750 pF
 C610-6C Trimming capacitor 20—250 pF

Fuses

0.2A-6C Fuse 0.2A 5 x 30 mm slow
 2A-6C Fuse 2A 5 x 30 mm slow
 0.2A-1-6C Fuse 3/8A 250 V (for transformer 277)
 2A-1-6C Fuse 2A 125 V (for transformer 277)

Coils

L4-6C Coil L4
 L5-6C Coil L5
 L6-6C Coil L6
 L7-6C Coil L7
 L8-6C Coil L8
 L601-6C Coil L601

Potentiometers

R18/R19-6C Potentiometer, 2 x 500 kohms
 R18/R19-1-6C > 2 x 500 kohms Introduced from serial No. 689801
 R109/R110-6C > 2 x 250 kohms
 R109/R110-1-6C > 2 x 250 kohms Introduced from serial No. 689801
 R115-6C Trimming potentiometer, 250 kohms
 R116-6C > > 250 kohms
 R137-6C > > 500 kohms
 R138-6C > > 500 kohms
 R233-6C > > 200 kohms
 R234-6C > > 200 kohms
 R301-1-6C > > 1 Mohm
 R302-1-6C > > 1 Mohm
 R607-6C > > 47 kohms
 R609-6C > > 100 kohms
 R610-6C > > 47 kohms
 R612-6C > > 100 kohms

Rectifiers

B250 C75-6C
 B30 C1000-6C

Heads

41H-64x Erase head
 42H-64x Bias head
 55H-64x Record head (44H)
 56H-64x Playback head (45H)

Resistors

Ref. No.	Description	Notes
R1-6C	1 Mohm 1/2 W 10 0/0	
R2-6C	68 kohms 1/2 W 10 0/0	
R3-6C	39 kohms 1/2 W 10 0/0	
R4-6C	39 kohms 1/2 W 10 0/0	
R5-6C	68 kohms 1/2 W 10 0/0	
R6-6C	1 Mohm 1/2 W 10 0/0	
R9-6C	1,2 kohm 1/3 W ¹⁾ 5 0/0	
R11-6C	4 kohms Wirewound 5 0/0	
R13-6C	15 kohms Wirewound 5 0/0	
R14-6C	1,2 kohm Wirewound 5 0/0	
R15-6C	5 ohms Wirewound 5 0/0	
R17-6C	51 ohms 1/2 W 10 0/0	
R20-6C	30 kohms 1/3 W ¹⁾ 5 0/0	
R21-6C	30 kohms 1/3 W ¹⁾ 5 0/0	
R30-6C	39 kohms 1/2 W 10 0/0	
R31-6C	39 kohms 1/2 W 10 0/0	
R32-6C	3,3 kohms 1/2 W 10 0/0	
R33-6C	3,3 kohms 1/2 W 10 0/0	
R34-6C	82 kohms 1/2 W 10 0/0	
R35-6C	82 kohms 1/2 W 10 0/0	
R36-6C	10 kohms 1/2 W 10 0/0	
R37-6C	10 kohms 1/2 W 10 0/0	
R38-6C	10 kohms 1/2 W 10 0/0	
R39-6C	10 kohms 1/2 W 10 0/0	
R40-6C	91 kohms 1/2 W 10 0/0	
R41-6C	91 kohms 1/2 W 10 0/0	
R42-6C	10 kohms 1/2 W 10 0/0	
R43-6C	10 kohms 1/2 W 10 0/0	
R44-6C	22 kohms 1/2 W 10 0/0	Changed from serial No. 691313
R45-6C	22 kohms 1/2 W 10 0/0	Changed from serial No. 691313

¹⁾ Deposited carbon resistor.

62

Ref. No.	Description	Notes
R46-6C	100 kohms $\frac{1}{2}$ W	10 %
R47-6C	100 kohms $\frac{1}{2}$ W	
R48-6C	22 kohms $\frac{1}{2}$ W	10 %
R49-6C	22 kohms $\frac{1}{2}$ W	
R50-6C	390 kohms $\frac{1}{2}$ W	10 %
R51-6C	390 kohms $\frac{1}{2}$ W	
R101-6C	5,1 Mohms $\frac{1}{2}$ W	10 %
R102-6C	5,1 Mohms $\frac{1}{2}$ W	
R103-6C	10 kohms $\frac{1}{2}$ W	10 %
R104-6C	10 kohms $\frac{1}{2}$ W	
R105-6C	2 kohms 1 W ¹⁾	10 %
R106-6C	2 kohms 1 W ¹⁾	
R107-6C	100 kohms 1 W ¹⁾	10 %
R108-6C	100 kohms 1 W ¹⁾	
R111-6C	2 kohms $\frac{1}{2}$ W	10 %
R112-6C	2 kohms $\frac{1}{2}$ W	
R113-6C	100 kohms 1 W	10 %
R114-6C	100 kohms 1 W	
R115-6C	100 kohms $\frac{1}{2}$ W	10 %
R115B-6C	150 kohms $\frac{1}{2}$ W	
R116-6C	100 kohms $\frac{1}{2}$ W	10 %
R116B-6C	150 kohms $\frac{1}{2}$ W	
R117-6C	20 kohms $\frac{1}{3}$ W ¹⁾	5 %
R118-6C	20 kohms $\frac{1}{3}$ W ¹⁾	
R119A-6C	2,2 kohms $\frac{1}{2}$ W	10 %
R119B-6C	1,8 kohm $\frac{1}{2}$ W	
R120A-6C	2,2 kohms $\frac{1}{2}$ W	10 %
R120B-6C	1,8 kohm $\frac{1}{2}$ W	
R121-6C	100 kohms 1 W	10 %
R122-6C	100 kohms 1 W	
R123-6C	510 kohms $\frac{1}{2}$ W	10 %
R124-6C	510 kohms $\frac{1}{2}$ W	
R125-6C	100 kohms $\frac{1}{2}$ W	10 %
R126-6C	100 kohms $\frac{1}{2}$ W	
R127-6C	1 Mohm $\frac{1}{2}$ W	10 % σ
R128-6C	1 Mohm $\frac{1}{2}$ W	
R129-6C	390 ohms $\frac{1}{2}$ W	10 %
R130-6C	390 ohms $\frac{1}{2}$ W	
R131-6C	82 kohms 1 W	10 %
R132-6C	82 kohms 1 W	
R133-6C	100 kohms $\frac{1}{2}$ W	10 %
R134-6C	100 kohms $\frac{1}{2}$ W	
R135-6C	2 kohms $\frac{1}{3}$ W ¹⁾	5 %
R136-6C	2 kohms $\frac{1}{3}$ W ¹⁾	
R201-6C	750 kohms $\frac{1}{2}$ W	10 %
R202-6C	750 kohms $\frac{1}{2}$ W	
R203-6C	1 Mohm $\frac{1}{3}$ W ¹⁾	10 %
R204-6C	1 Mohm $\frac{1}{3}$ W ¹⁾	
R205-6C	2 kohms 1 W ¹⁾	10 %
R206-6C	2 kohms 1 W ¹⁾	
R207-6C	47 kohms $\frac{1}{2}$ W	5 %
R208-6C	47 kohms $\frac{1}{2}$ W	
R209-6C	1 Mohm $\frac{1}{2}$ W	10 %
R210-6C	1 Mohm $\frac{1}{2}$ W	
R211-6C	1 kohm $\frac{1}{2}$ W	10 %
R212-6C	1 kohm $\frac{1}{2}$ W	
R213-6C	100 kohms 1 W ¹⁾	10 %
R214-6C	100 kohms 1 W ¹⁾	
R215-6C	1 Mohm $\frac{1}{2}$ W	10 %
R216-6C	1 Mohm $\frac{1}{2}$ W	
R217-6C	7,5 kohms $\frac{1}{2}$ W	10 %

Introduced from serial No. 691313
Introduced from serial No. 691313

¹⁾ Deposited carbon resistor.

46

Ref. No.	Description	Notes
R218-6C	7,5 kohms 1/2 W 10 0/0	
R219-6C	10 kohms 1/2 W 10 0/0	
R220-6C	10 kohms 1/2 W 10 0/0	
R221-6C	8,2 kohms 1/2 W 10 0/0	
R222-6C	8,2 kohms 1/2 W 10 0/0	
R223-6C	39 kohms 1/3 W ¹⁾ 5 0/0	
R224-6C	39 kohms 1/3 W ¹⁾ 5 0/0	
R225-6C	7,5 kohms 1/2 W 10 0/0	
R226-6C	7,5 kohms 1/2 W 10 0/0	
R227-6C	510 ohms 1/2 W 10 0/0	
R228-6C	510 ohms 1/2 W 10 0/0	
R229-6C	82 kohms 1 W 10 0/0	
R230-6C	82 kohms 1 W 10 0/0	
R231-6C	680 kohms 1/2 W 10 0/0	
R232-6C	680 kohms 1/2 W 10 0/0	
R235-6C	51 kohms 1/2 W 10 0/0	
R236-6C	51 kohms 1/2 W 10 0/0	
R237-6C	1 Mohm 1/2 W 10 0/0	
R238-6C	1 Mohm 1/2 W 10 0/0	
R239-6C	2 kohms 1/2 W 10 0/0	
R240-6C	2 kohms 1/2 W 10 0/0	
R241-6C	6,8 kohms 1 W ¹⁾ 10 0/0	
R242-6C	6,8 kohms 1 W ¹⁾ 10 0/0	
R243-6C	15 kohms 1/2 W 10 0/0	
R244-6C	15 kohms 1/2 W 10 0/0	
R245-6C	2 kohms 1/3 W ¹⁾ 5 0/0	
R246-6C	2 kohms 1/3 W ¹⁾ 5 0/0	
R305-6C	51 kohms 1/2 W 10 0/0	
R401-6C	150 kohms 1/2 W 10 0/0	
R402-6C	150 kohms 1/2 W 10 0/0	
R403-6C	150 kohms 1 W 10 0/0	
R404-6C	150 kohms 1 W 10 0/0	
R405-6C	1 Mohm 1/2 W 10 0/0	
R406-6C	1 Mohm 1/2 W 10 0/0	
R407-6C	10 Mohms 1/2 W 10 0/0	
R408-6C	10 Mohms 1/2 W 10 0/0	
R501-6C	22 Mohms 1/2 W 10 0/0	
R502-6C	22 Mohms 1/2 W 10 0/0	
R503-6C	510 kohms 1/2 W 10 0/0	
R504-6C	5,6 kohms 1/2 W 10 0/0	
R505-6C	1 kohm 1/2 W 10 0/0	
R506-6C	51 kohms 1/2 W 10 0/0	
R507-6C	470 ohms 1/2 W 10 0/0	
R508-6C	10 kohms 1/2 W 10 0/0	
R509-6C	470 ohms 1/2 W 10 0/0	
R510-6C	3,3 kohms 1/2 W 10 0/0	
R601-6C	20 kohms 1/2 W 10 0/0	
R602-6C	2 kohms 1/2 W 10 0/0	
R603-6C	20 kohms 1/2 W 10 0/0	
R604-6C	20 kohms 1/2 W 10 0/0	
R605-6C	2 kohms 1/2 W 10 0/0	
R606-6C	20 kohms 1/2 W 10 0/0	
R608-6C	51 kohms 1/2 W 10 0/0	
R611-6C	51 kohms 1/2 W 10 0/0	
R613-6C	130 ohms 1/2 W 10 0/0	
R614-6C	33 ohms 1/3 W ¹⁾ 5 0/0	
R615-6C	130 ohms 1/2 W 10 0/0	
R616-6C	130 ohms 1/2 W 10 0/0	
R617-6C	51 kohms 1/2 W 10 0/0	
R618-6C	51 kohms 1/2 W 10 0/0	

¹⁾ Deposited carbon resistor.

Capacitors

Ref. No.	Description	Notes	Type
C1-6C	10 pF 500 V .5 pF	Ceramic	
C2-6C	200 pF 125 V 20 %	Styroflex	
C3-6C	200 pF 125 V 20 %	Styroflex	
C4-6C	10 pF 500 V .5 pF	Ceramic	
C5-6C ¹⁾	40—20—10 μF 350 V	Electrolytic	
C6-6C ¹⁾	40—20—10 μF 350 V	Electrolytic	
C7-6C ²⁾	40—20—10 μF 350 V	Electrolytic	
C8-6C ²⁾	40—20—10 μF 350 V	Electrolytic	
C9-6C	1000 + 1000 μF 30/35 V	Electrolytic with inst. sleeve	
C10-6C	10 pF 500 V	Ceramic	
C11-6C ²⁾	40—20—10 μF 350 V	Electrolytic	
C12-6C	1000 + 1000 μF 30/35 V	Electrolytic with inst. sleeve	
C13-6C	.1 μF 400 V 20 %	Oil paper	
C14-6C	1,6 μF	Oil paper	Changed from serial No. 694896
C15-6C	.1 μF 400 V 20 %	Metalized paper	
C16-6C	.1 μF 400 V 20 %	Metalized paper	
C17-6C ¹⁾	40—20—10 μF 350 V	Electrolytic	
C18-6C	200 pF 500 V 20 %	Styroflex	
C20-6C	1000 pF 160 V 10 %	Styroflex	
C21-6C	120 pF 125 V 10 %	Styroflex	Removed from serial No. 691313
C22-6C	120 pF 125 V 10 %	Styroflex	Removed from serial No. 691313
C30-6C	800 pF 160 V 2,5 %	Styroflex	
C31-6C	800 pF 160 V 2,5 %	Styroflex	
C32-6C	180 pF 500 V 10 %	Ceramic	
C33-6C	180 pF 500 V 10 %	Ceramic	
C34-6C	500 pF 160 V 2,5 %	Styroflex	
C35-6C	500 pF 160 V 2,5 %	Styroflex	
C36-6C	25 pF 500 V 10 %	Ceramic	
C37-6C	25 pF 500 V 10 %	Ceramic	
C101-6C	25 μF 15/18 V	Electrolytic	
C102-6C	25 μF 15/18 V	Electrolytic	
C103-6C	.022 μF 400 V 20 %	Metalized paper	
C104-6C	.022 μF 400 V 20 %	Metalized paper	
C105-6C	4000 pF 150 V 10 %	Metalized paper	
C106-6C	4000 pF 150 V 10 %	Metalized paper	
C107-6C	.047 μF 400 V 20 %	Metalized paper	
C108-6C	.047 μF 400 V 20 %	Metalized paper	
C110-6C	16 μF 350 V	Electrolytic	
C110-6C	16 μF 350 V	Electrolytic	
C111-6C	5000 pF 150 V 10 %	Metalized paper	
C112-6C	5000 pF 150 V 10 %	Metalized paper	
C117-6C	.010 μF 400 V 20 %	Metalized paper	Changed from serial No. 693096
C118-6C	.010 μF 400 V 20 %	Metalized paper	Changed from serial No. 693096
C119-6C	.047 μF 400 V 20 %	Metalized paper	
C120-6C	.047 μF 400 V 20 %	Metalized paper	
C121-6C	120 pF 500 V 10 %	Ceramic	
C122-6C	120 pF 500 V 10 %	Ceramic	
C123-6C	250 pF 400 V 5 %	Ceramic	
C124-6C	250 pF 400 V 5 %	Ceramic	
C125-6C	470 pF 500 V 10 %	Ceramic	
C126-6C	470 pF 500 V 10 %	Ceramic	
C127-6C	16 μF 350 V	Electrolytic	
C128-6C	16 μF 350 V	Electrolytic	
C129-6C	15 pF 500 V 5 %	Ceramic	
C130-6C	15 pF 500 V 5 %	Ceramic	
C131-6C	25 μF 15/18 V	Electrolytic	

²⁾ C7, C8 and C11 in the same can. ¹⁾ C5, C6 and C17 in the same can.

Ref. No.	Description	Type	Notes
C132-6C	25 μ F 15/18 V	Electrolytic	
C133-6C	.047 μ F 400 V 20 %	Metalized paper	
C134-6C	.047 μ F 400 V 20 %	Metalized paper	
C135-6C	.068 μ F 250 V 20 %	Polyester	
C136-6C	.068 μ F 250 V 20 %	Polyester	
C137-6C	.1 μ F 200 V 20 %	Ceramic	Introduced from serial No. 687736
C138-6C	.1 μ F 200 V 20 %	Ceramic	Introduced from serial No. 687736
C201-6C	47 pF 500 V 10 %	Metalized paper	
C202-6C	47 pF 500 V 10 %	Metalized paper	
C203-6C	400 pF 160 V 10 %	Styroflex	
C204-6C	400 pF 160 V 10 %	Styroflex	
C205-6C	.022 μ F 400 V 20 %	Metalized paper	
C206-6C	.022 μ F 400 V 20 %	Metalized paper	
C207-6C	25 μ F 15/18	Electrolytic	
C208-6C	25 μ F 15/18	Electrolytic	
C209-6C	.022 μ F 400 V 20 %	Metalized paper	
C210-6C	.022 μ F 400 V 20 %	Metalized paper	
C211-6C	.047 μ F 400 V 20 %	Metalized paper	
C212-6C	.047 μ F 400 V 20 %	Metalized paper	
C213-6C	16 μ F 350 V	Electrolytic	
C214-6C	16 μ F 350 V	Electrolytic	
C215-6C	500 pF 600 V 10 %	Metalized paper	
C216-6C	500 pF 600 V 10 %	Metalized paper	
C217-6C	.047 μ F 400 V 20 %	Metalized paper	
C218-6C	.047 μ F 400 V 20 %	Metalized paper	
C219-6C	5000 pF 150 V 10 %	Metalized paper	
C220-6C	5000 pF 150 V 10 %	Metalized paper	
C221-6C	.022 μ F 400 V 20 %	Metalized paper	
C222-6C	.022 μ F 400 V 20 %	Metalized paper	
C223-6C	16 μ F 350 V	Electrolytic	
C224-6C	16 μ F 350 V	Electrolytic	
C225-6C	2 μ F 100/110 V	Electrolytic	
C226-6C	2 μ F 100/110 V	Electrolytic	
C227-6C	.01 μ F 150 V 10 %	Metalized paper	
C228-6C	.01 μ F 150 V 10 %	Metalized paper	
C304-6C	.1 μ F 400 V 20 %	Metalized paper	
C401-6C	.01 μ F 400 20 %	Metalized paper	
C402-6C	.01 μ F 400 20 %	Metalized paper	
C405-6C	.022 μ F 400 V 20 %	Metalized paper	
C406-6C	.022 μ F 400 V 20 %	Metalized paper	
C501-6C	.68 μ F 100 V 20 %	Polyester	
C502-6C	100 μ F 16 V	Electrolytic	
C503-6C	100 μ F 16 V	Electrolytic	
C504-6C	47 pF 400 V 20 %	Ceramic	
C601-6C	220 pF 630 V 2.5 %	Styroflex	Introduced from serial No. 690406
C602-6C	50—750 pF	Mica, trimming capacitor	
C603-6C	220 pF 630 V 2.5 %	Ceramic	Introduced from serial No. 690406
C604-6C	50—750 pF	Mica, trimming capacitor	
C605-6C	.1 μ F 250 V 20 %	Polyester	
C606-6C	.1 μ F 250 V 20 %	Polyester	
C607-6C	.1 μ F 250 V 20 %	Polyester	
C608-6C	.1 μ F 250 V 20 %	Polyester	
C609-6C	500 pF 125 V 2.5 %	Styroflex	
C610-6C	20—250 pF	Mica, trimming capacitor	
C611-6C	300 pF 500 V 10 %	Styroflex	
C612-6C	.1 μ F 250 V 20 %	Polyester	
C613-6C	80 μ F 25 V	Electrolytic	
C614-6C	5000 pF 15/125 V 10 %	Styroflex	
C615-6C	5000 pF 15/125 V 10 %	Styroflex	
C616-6C	1000 pF 160 V 5 %	Styroflex	
C617-6C	1000 pF 160 V 5 %	Styroflex	

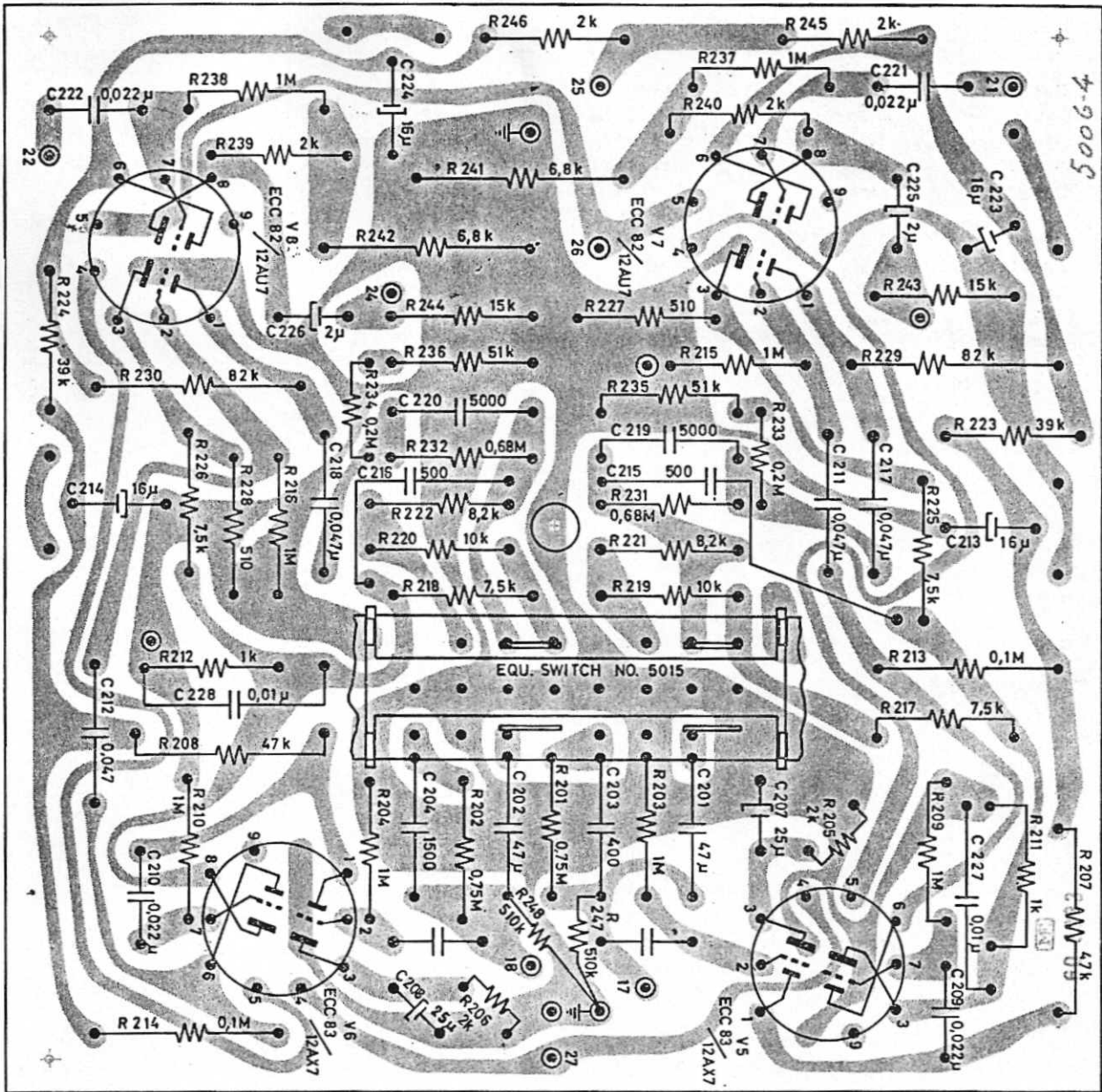

Fig. 60. The playback amplifier board, seen from printed side.

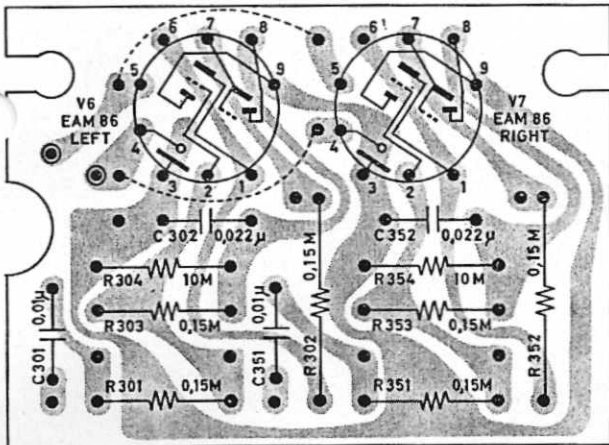

Fig. 61. The indicator board, seen from printed side.

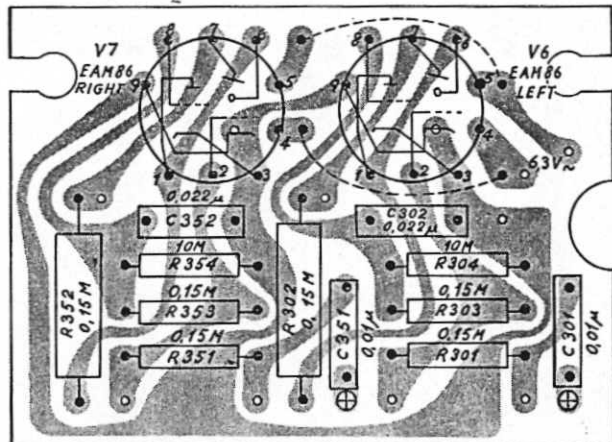

Fig. 62. The indicator board, seen from component side.

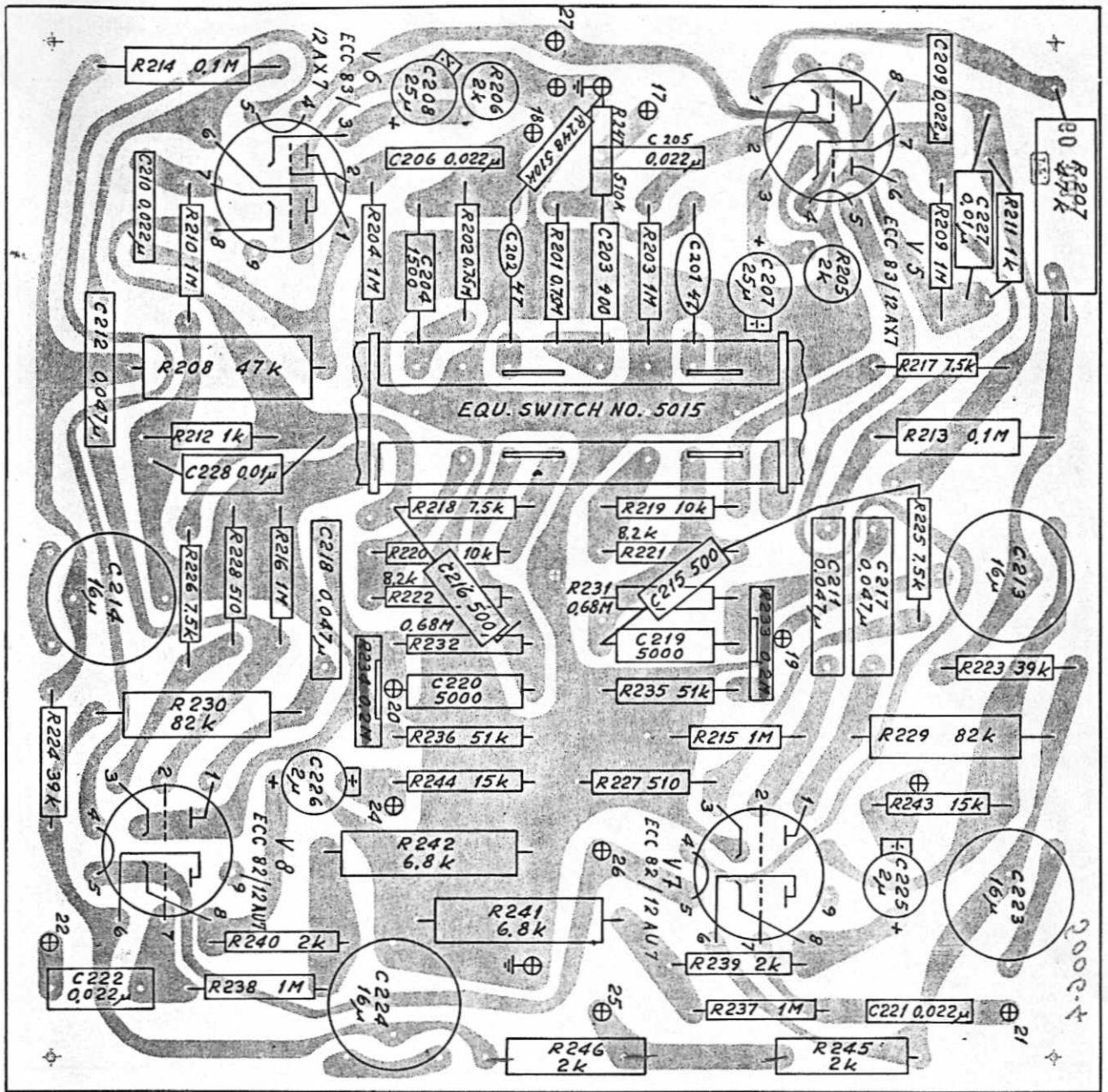

Fig. 63. The playback amplifier board, seen from component side.

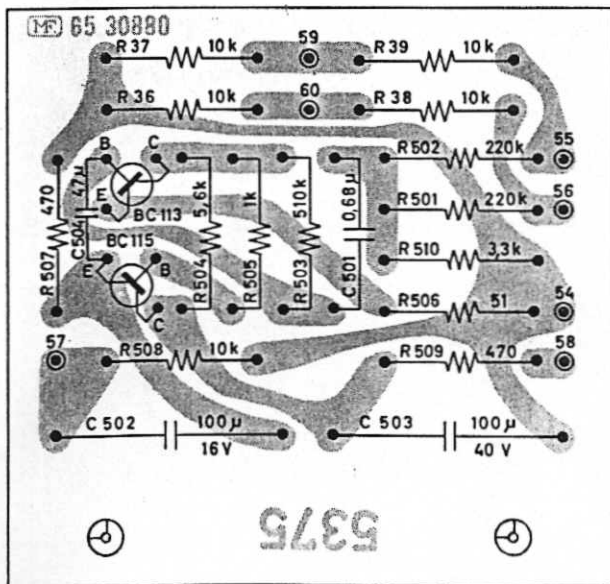

Fig. 64. The center channel amplifier board, seen from printed side.

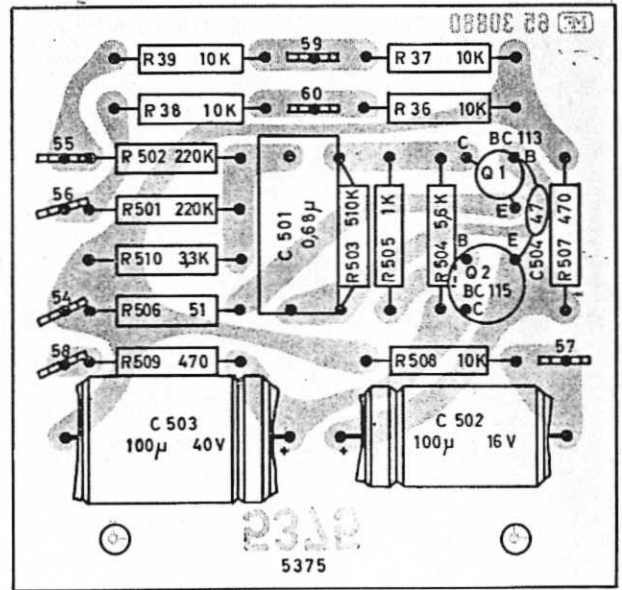

Fig. 65. The center channel amplifier board, seen from component side.

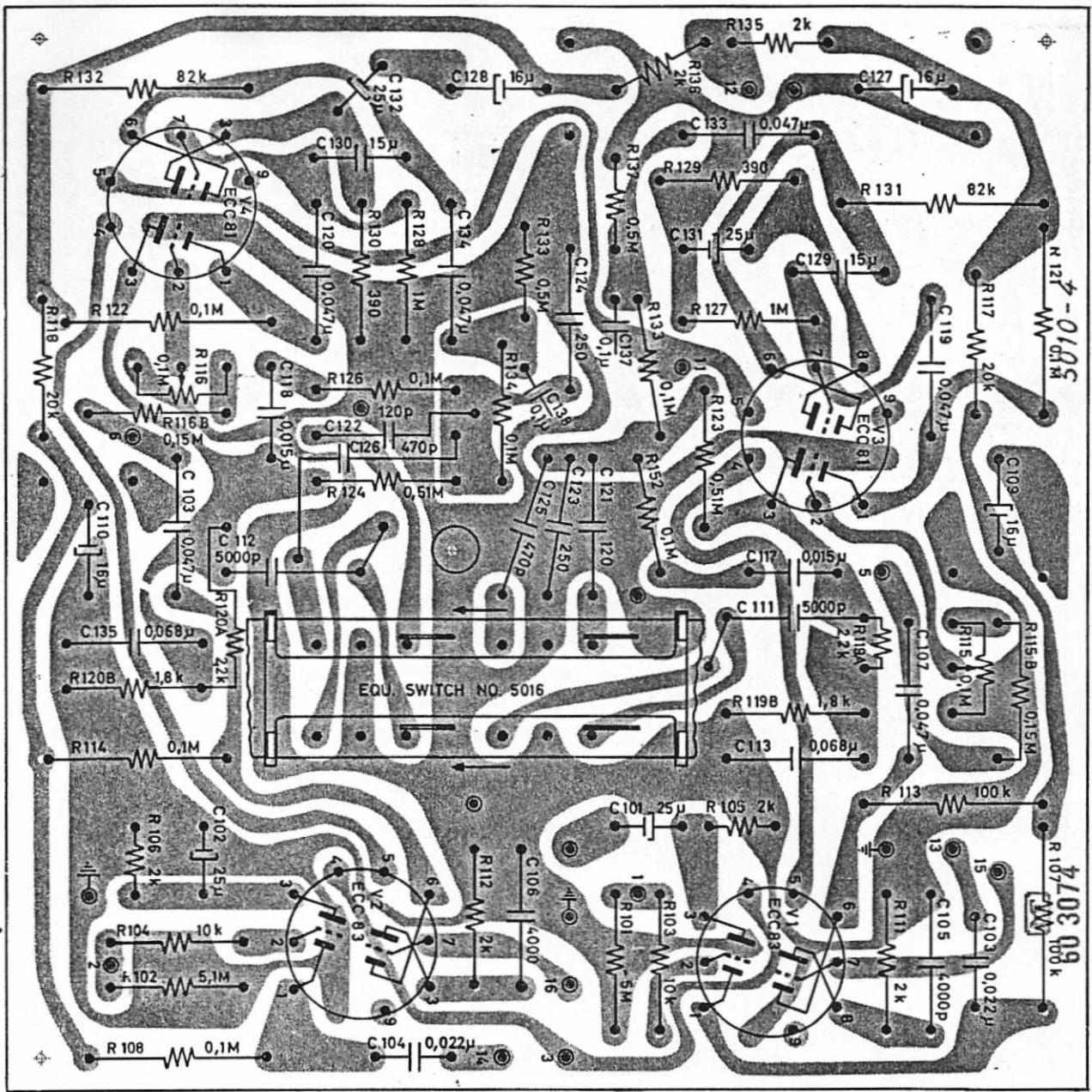

Fig. 66. The record amplifier board, seen from printed side.

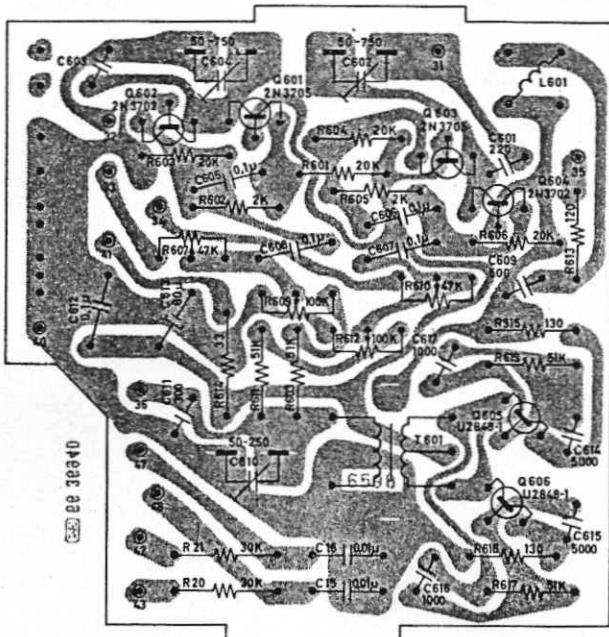

Fig. 67. The oscillator board, seen from printed side.

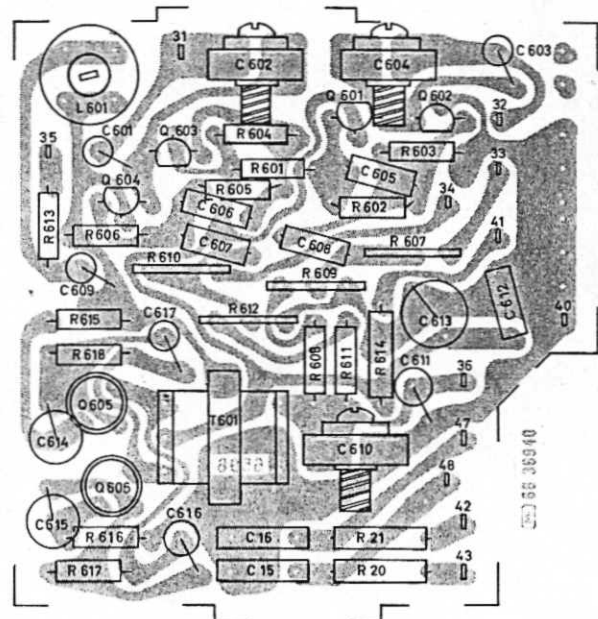

Fig. 68. The oscillator board, seen from component side.

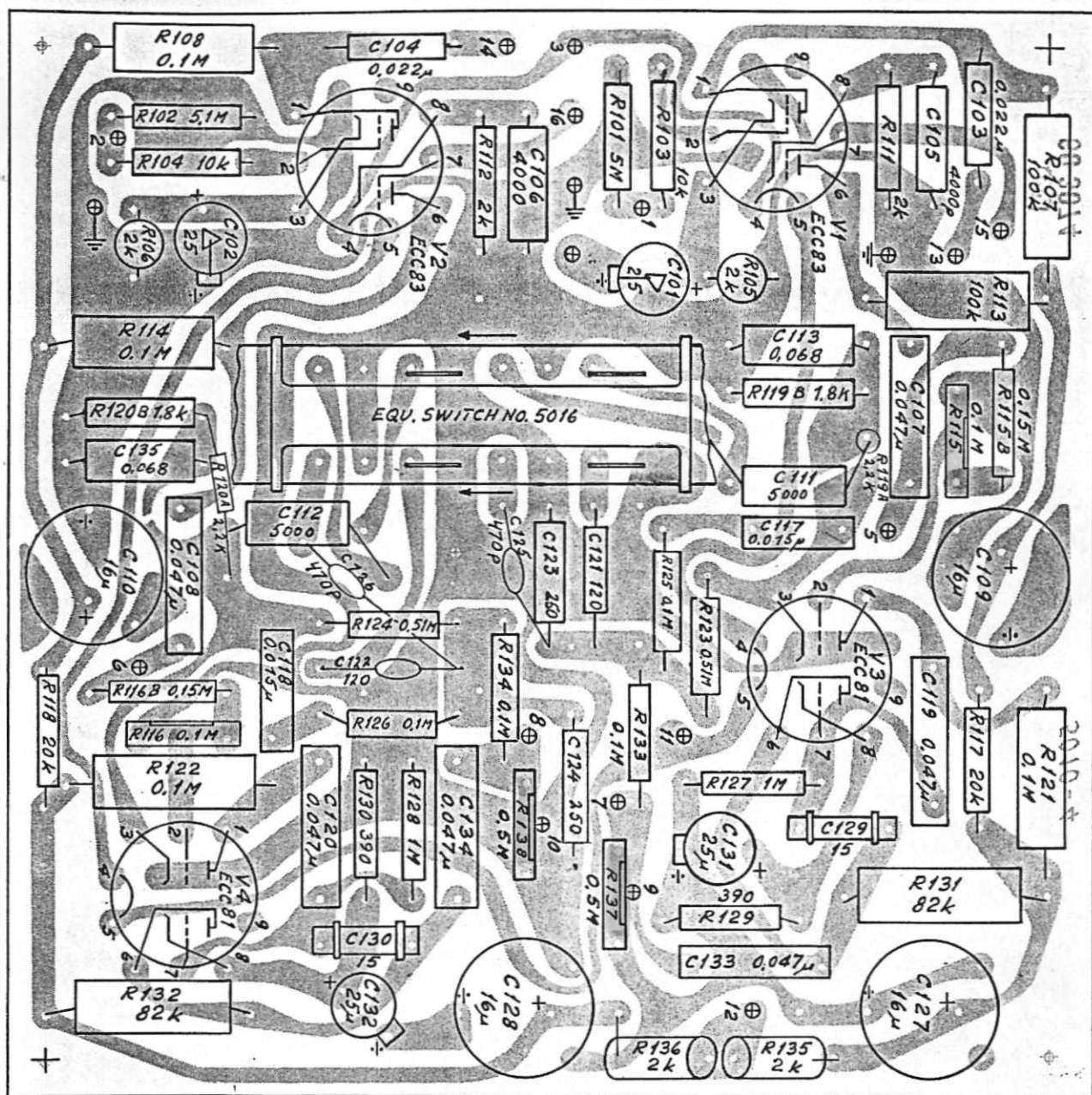

Fig. 69. The record amplifier board, seen from component side.

6.1 MODIFICATION FROM 220 V 50 Hz TO 110 V 60 Hz OPERATION

When changing from 220 V 50 Hz to 110 V 60 Hz operation, the diameter of the motor pulley is reduced to compensate for the increased mains frequency. The motor capacitor C14, 1.6 µF is not changed when connecting from 50 Hz to 60 Hz operation. The transformer 11.1-273-1-6C is equipped with a mains selec-

tor for 110-125-145-200-220-245 V and can be used for 50-60 Hz.

Ref. para 4.4. instruction for changing the motor pulley. The type number for the 50 Hz motor pulley is 62.1-5750-6C. The transformer 11.1-277-6C, 115 V 60 Hz, must be changed when modifying the tape recorder from 110 V 60 Hz, to 220 V 50 Hz operation, as it is not equipped with a mains selector. Change to transformer, type 11.1-273-1-6C.

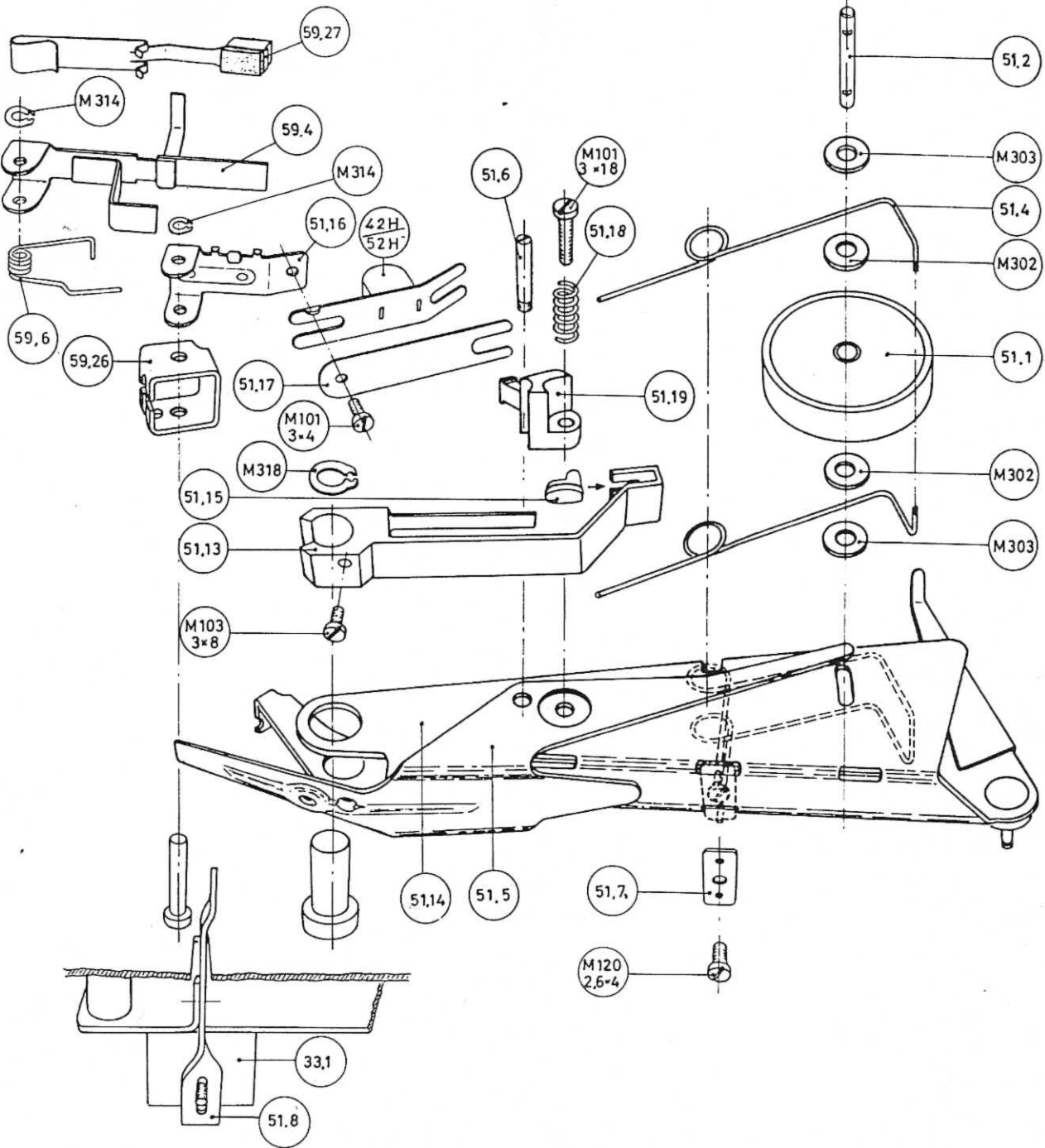

Fig. 70. The pressure wheel assembly with detailed parts, exploded view.

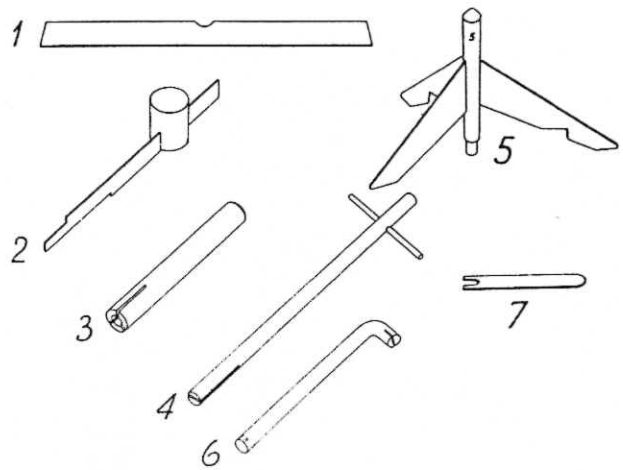

Fig. 71. The special tools.

6x

LUBRICATING

The Papst motor:

The Papst motor should be lubricated after every 1500 hours of use. The radial bearings should be lubricated with a Teresso oil 43 or 47 from Esso. Feed the oil into upper bearing through the slit under the upper bakelite washer. The oil will fill the upper bearing and follow a wick of felt down to the lower bearing. The thrust bearing mounted on the bottom plate of the motor should be lubricated with a SAE 80 hypoid oil.

The Engel motor:

The Engel motor should be lubricated after approx. every 3000 hours of use.

The upper and the lower bearing should be lubricated with a Teresso oil 43 or 47 from Esso.

The self-lubricating bearings:

The turntables, the flywheel and the speed transfer wheel are mounted in self-lubricating bearings and should usually not be lubricated. If, however, it should be necessary to lubricate the bearings for any reason, use Teresso oil 43 or 47 from Esso.

Note: Utmost care must be taken while lubricating, use only one fraction of a drop of oil for each bearing. Excessive oil might seriously affect the friction drive.

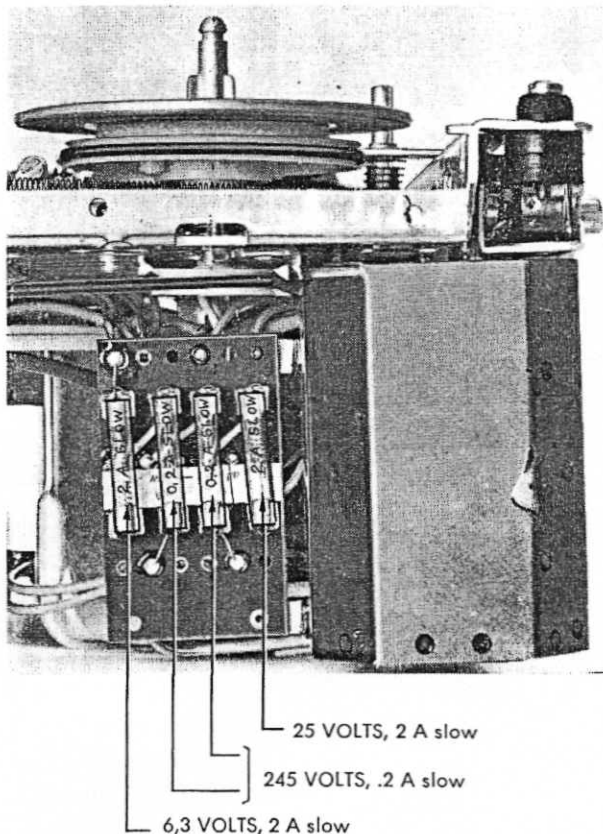

Fig. 73. The position of the fuses, 60 Hz model.

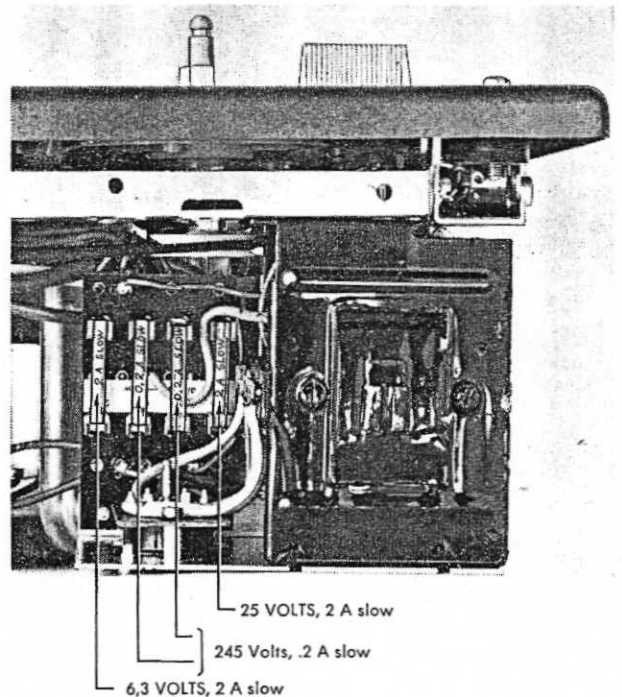
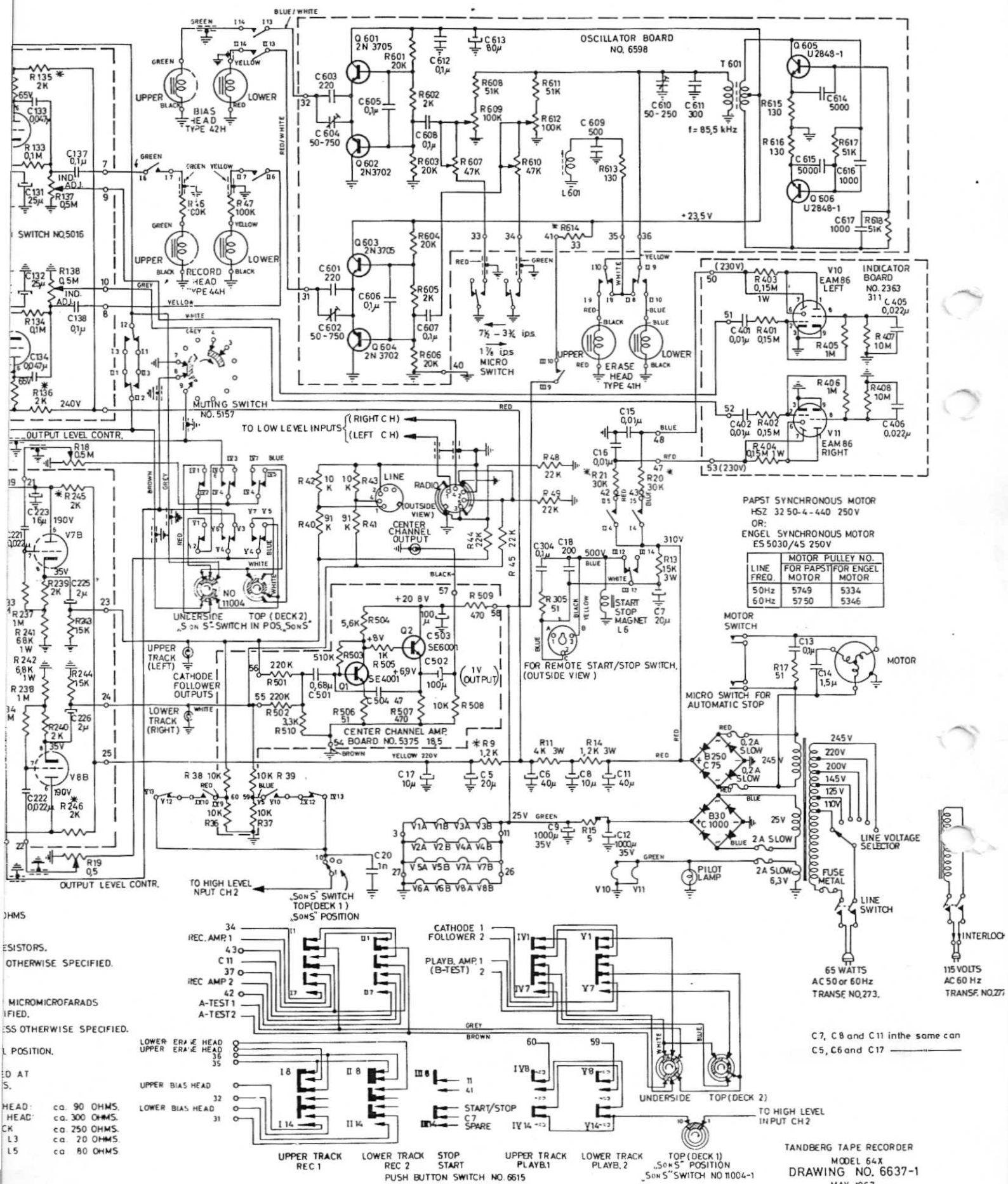
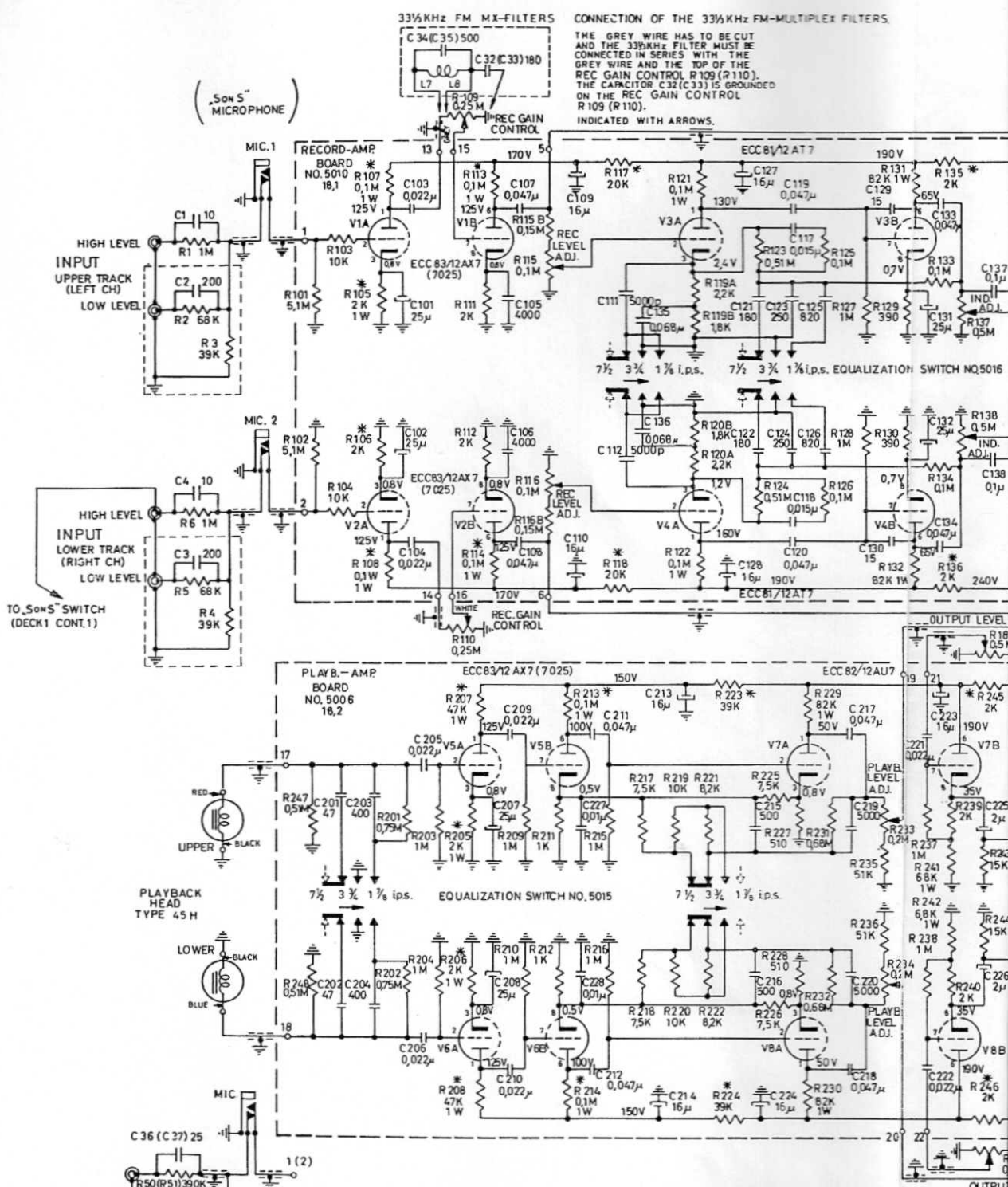

Fig. 74. The position of the fuses, 50 Hz model.



TANDBERG TAPE RECORDER
MODEL 64X
DRAWING NO. 6637-1
MAY 1967

Fig. 72.



NOTES:

RESISTORS INDICATED IN OHMS
 K = 1,000 OHMS
 M = 1,000,000 OHMS.
 * = DEPOSITED CARBON RESISTORS.
 RESISTORS ± 10% UNLESS OTHERWISE SPECIFIED
 3₀ = CONNECTION POINTS
 CAPACITORS INDICATED IN MICROMICROFARAD UNLESS OTHERWISE SPECIFIED.
 CAPACITORS ± 20% UNLESS OTHERWISE SPECIFIED.
 ALL SWITCHES IN NEUTRAL POSITION.
 ALL VOLTAGES MEASURED AT LINE VOLTAGE 110 VOLTS.
 RESISTANCE IN ERASE HEAD: ca. 90
 RESISTANCE IN RECORD HEAD: ca. 300
 RESISTANCE IN PLAYBACK: ca. 250
 RESISTANCE IN L2 AND L3: ca. 20
 RESISTANCE IN L4 AND L5: ca. 80

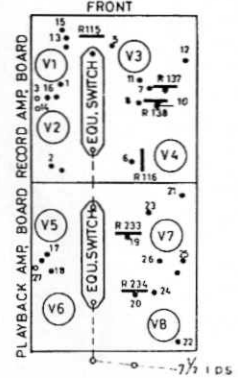
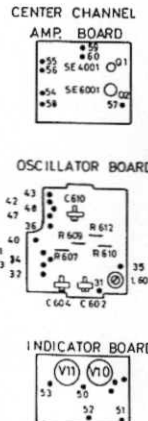

6x



Tandbergs Radiofabrikk A/S, Kjelsås.

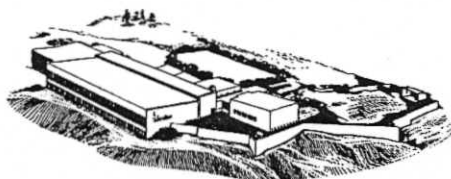

Tandbergs Radiofabrikk A/S, div. Kjeller.

TANDBERGS RADIOFABRIKK A/S

P. O. B. 9, Korsvoll, Oslo 8, Norway