

TANDBERG

SERVICE MANUAL AND LOGIC CIRCUITS DESCRIPTION

9100X/9200XD



LOGIC CIRCUITS DESCRIPTION

All paragraphs in the first half of the book are valid for the 9000 series.

CONTENTS

Paragraph	Page
1.0 Logic circuit types and triggering methods	3
2.0 General description	7
3.0 Operating modes	11
4.0 Table of operating sequences	19
Circuit diagram logic, model 9000X . . .	21
Circuit diagram logic, model 9100X and 9200XD	22
The signal path to stop from power on .	23
The signal path to play from stop	24

MECHANICAL AND ELECTRICAL ADJUSTMENTS

All paragraphs in the other half are valid for models 9100X and 9200XD.

CONTENTS

Paragraph	Page
1.0 Dismantling	25
2.0 Regular maintenance	26
3.0 Mechanical servicing	27
4.0 Tape-path adjustments	30
5.0 Erase and bias circuits	32
6.0 Head alignment four track	33
7.0 Head alignment, without test tape, four track	35
8.0 Head alignment, two tracks	35
9.0 Modification from four to two tracks . .	36
10.0 Changing from 220 V/50 Hz to 115 V/60 Hz	36
11.0 Changing the photo-electric end-stop . .	37
Adjustments table, model 9100X and 9200XD	38
Circuit diagrams and printed boards, model 9100X and 9200XD	39

1.0 LOGIC CIRCUIT TYPES AND TRIGGERING METHODS

The circuits on the logic board are built up of and-gates (and-ports), nand-gates (not-and ports), monostable and bistable circuits.

The transistors in a logic circuit work either in saturation (conduct as a closed switch) or in cut-off (blocking as an open switch). The input of the circuit is connected to the base of a transistor via a diode, transistor or resistor, while the output is connected to the collector of the output transistor.

Voltage levels for the 9000X logic circuits are defines as:

High level	(logic 1)	8 to 18.0 V
Low level	(logic 0)	0 to 6.0 V
Threshold level		7.0 V

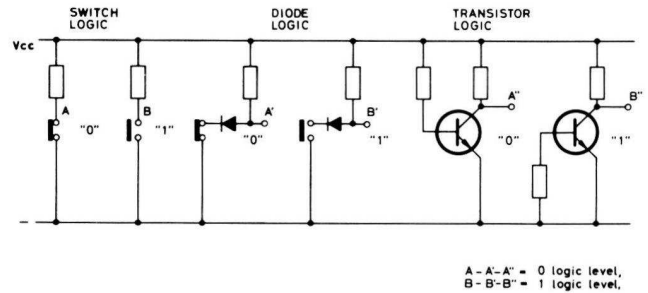

Fig. 1.1 Examples of elementary logic circuits showing the meaning of logic levels high "1" and low "0",

1.1 AND-GATE

Only when all the inputs are high (logic 1) can the output be high.

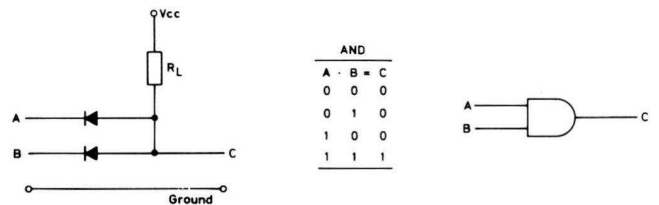

Fig. 1.2 AND-circuit, truth table and symbol

1.2 INVERTER, NOT-FUNCTION

The output signals are always the inverse (have the opposite logic level) of the input signal (0 is the inverse of 1 and vice versa). If all the inputs on a nand-gate are connected together an inverter is obtained. In general an inverter is combined with a logic function when the inverter is drawn with a small circle following the symbol for the function

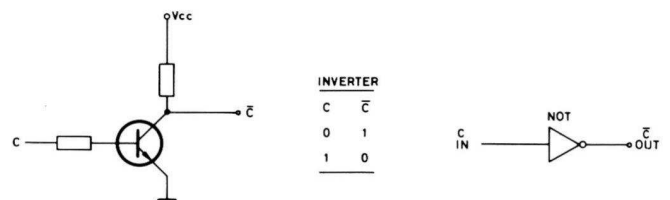

Fig. 1.3 INVERTER-circuit, truth table and symbol

1.3 NAND-GATE

A combination of an and-gate and an inverter forms a nand-gate. The output is low (0) only when all the inputs are high (1). It is enough that one of the inputs is low (0) for the output to be high (1).

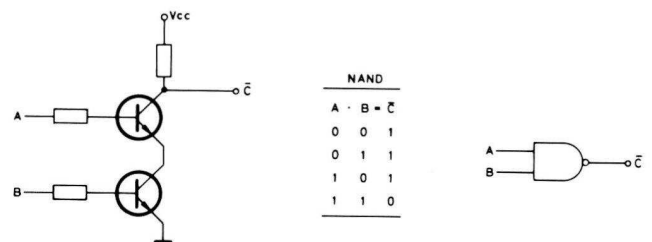

Fig. 1.4 NAND-circuit, truth table and symbol

1.4 FLIP-FLOP, BISTABLE MULTIVIBRATOR

A bistable circuit switches between two stable states dependent on the levels of the trigger pulse at the input.

When the input S (Set) goes low, the output Q goes high and remains in that state.

When the input R (Reset) goes low the output Q goes low and remains in that state.

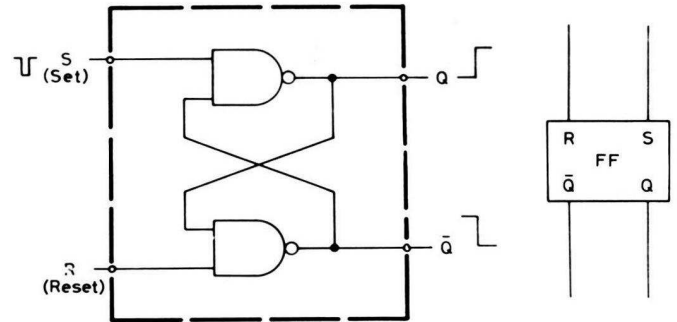

* Note for truth table:

The two inputs should preferably not be grounded (have logic 0) at the same time, but if it does happen the input which remains low longest will take over control.

The two outputs always have opposite levels.

PREVIOUS STATE		INPUT CONDITION		RESULT	
Q	Q̄	S	R	Q	Q̄
0	1	0	1	1	0
		0	0	1*	1*
		1	0	no change	
		1	1	no change	
1	0	1	0	0	1
		0	0	1*	1*
		0	1	no change	
		1	1	no change	

Fig. 1.5 FLIP-FLOP circuit, truth table and symbol

1.5 MONOSTABLE MULTIVIBRATOR

A monostable circuit has one stable condition and every trigger pulse at the input therefore forces the circuit out of this stable condition for a time which depends on the time constant of the circuit.

The time-constant T, and also the duration of the output pulse, are dependent on the component values in the R-C stage and can be calculated from the formula $T = 0.69 \times r \times c$. A typical example is shown in Figure 1.6.

Monostable circuits are used to determine the duration of a function, as for example the pull-in phase for the braking solenoid.

The monostable circuit in 9000X

The two monostable circuits that are used in the 9000X have a different configuration from the one shown in Figure 1.6. The difference lies in the R-C stage itself which in the 9000X consists of a capacitor (C) and a nand-circuit (R) where the capacitor is discharged by a leakage current through the nand-circuit.

The time constant (T) can be calculated by means of the special formula for this circuit; T in seconds and C in microfarads (uF), $T = 0.5 \times C$.

This is an approximate formula. The spread with IC's is very large, and often the formula $T = I \times C$ or even $T = 2 \times C$ can be more applicable.

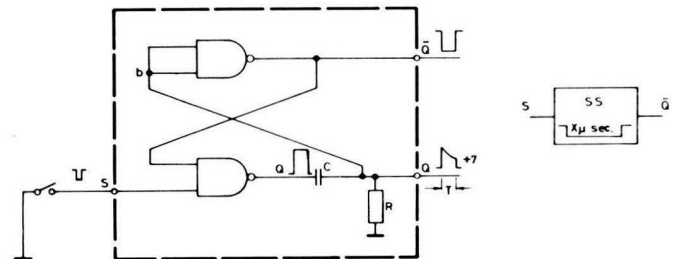

Fig. 1.6 Monostable circuit and symbol

**Method of operation for the monostable circuit
BRAKE MONOSTABLE (Figure 1.7).**

A low level from the switch S produces a high level on the B output and starts the time-constant (TIMER). When capacitor C discharges down to the threshold level on the TIMER output output B on the monostable goes low and sets the TIMER and monostable again.

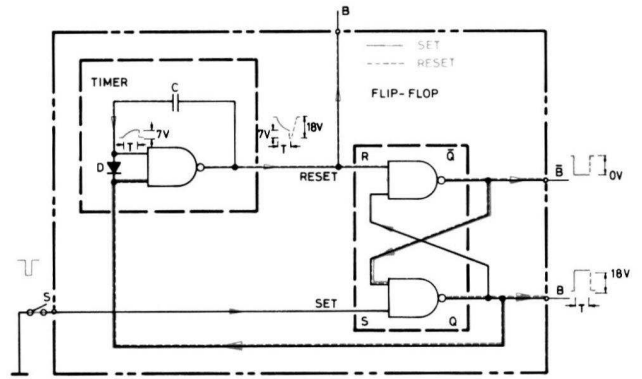

Fig. 1.7 BRAKE MONOSTABLE, the monostable circuit that is used to engage the brakes (output B)

1.6 DC AND AC TRIGGERING

The difference between dc and ac triggering lies in the coupling capacitor that separates the triggering source and the receiving circuit with ac triggering.

DC triggering

With dc triggering the voltage level of the DC trigger pulse is constant as long as the trigger signal is present. An example of this is the dc triggering of flip-flops.

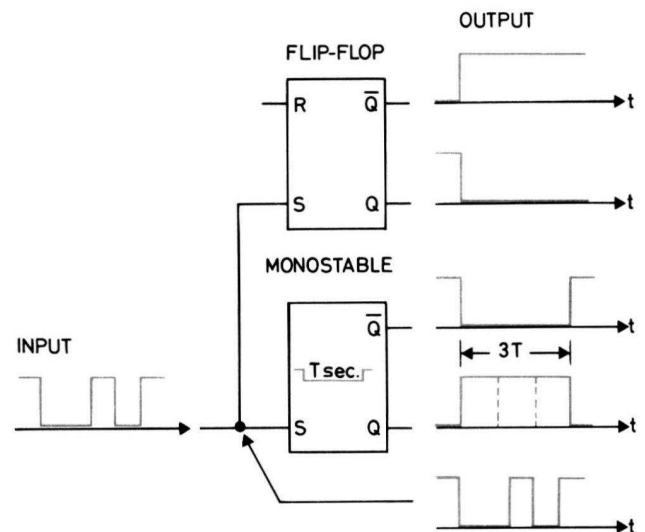

Fig. 1.8 DC triggering of a bistable and a monostable multivibrator

AC triggering

Because there is a capacitor between the triggering source and the receiving circuit, the receiving circuit will only get a short ac-start trigger pulse, even if the dc trigger pulse from the source circuit continues after the receiving circuit has been triggered.

AC triggering is used to avoid undesirable repetitive triggering of the receiving circuit, which would happen if a long duration dc trigger pulse were used. This point is particularly relevant to triggering for timing circuits (monostable flip-flop).

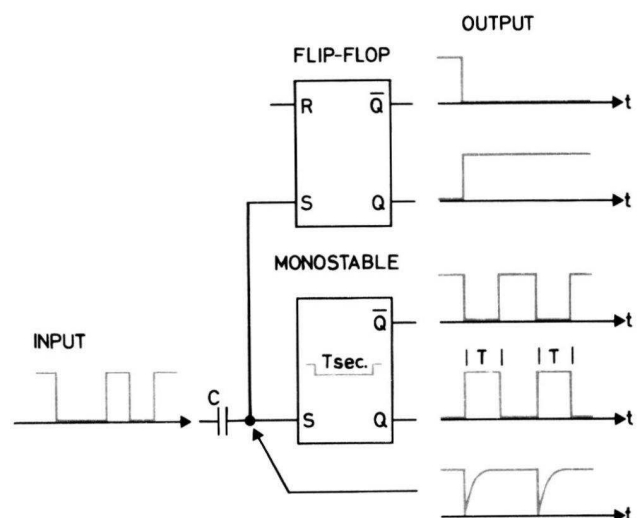

Fig. 1.9 AC triggering of a bistable and a monostable multivibrator

1.7 DC CONTROL

The difference between dc triggering and dc control is that with dc control a particular function is sustained (the circuit is activated) only as long as the control pulse lasts. The activated circuit is not capable of remaining activated (going over to the hold state) when the control signal is removed.

An example of this kind of operation is the dc control of the end-stop mode.

1.8 INHIBITOR CIRCUIT

An inhibitor is an ordinary nand circuit that has a special action. An inhibitor prevents a particular function from being carried out until one or several conditions are satisfied at the input of the nand circuit. In other words, even if the activating signal is present (as for example REC on U622A) the function (going into the RECORD mode) will not be carried out before the other inputs (D x S) have the same high level as the activating signal.

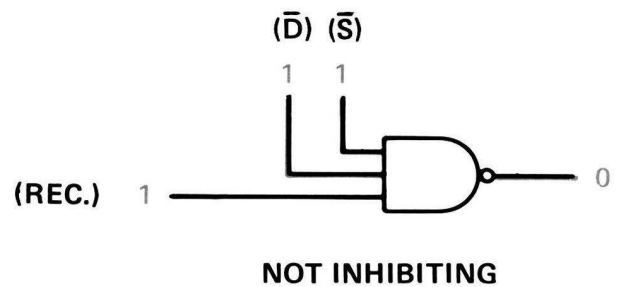
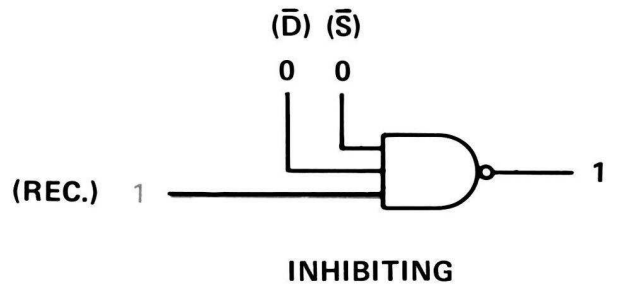

Fig. 1.10 Inhibitor-circuit

2.0 GENERAL DESCRIPTION

The logic circuits are controlled by:

- a) Power switch
- b) Mode touch-buttons
- c) REC SELECT switch
- d) End-stop sensor

The logic circuits control:

- a) Brake solenoid (activates the brakes).
- b) Brake solenoid switch (supplies the fast wind and rewind voltages, and the braking voltage to the reel motors).
- c) Pinch roller solenoid (activates the pinch roller, see section 2.5).
- d) Pinch roller solenoid switch (supplies the winding voltage for RECORD and PLAY and the braking voltage for the STOP mode).
- e) Wind relay (selects the voltage to the right reel motor).
- f) Rewind relay (selects the voltage to the left reel motor).
- g) Right reel motor (provides motion during fast winding, playback and recording).
- h) Left reel motor (provides motion during rewinding).
- i) Ind. and rec. amp. switch (activates several circuits during playback and recording, see sections 2.7, 2.8, and 2.9).
- j) Oscillator (the logic circuit grounds the oscillator and starts/stops it).

2.1 POWER SWITCH

It is assumed that none of the mode buttons is operated, so that the machine goes straight into the stop mode when power is switched on.

When the power is switched on, the capstan motor starts immediately and the transfer wheel solenoid receives current and pulls in the transfer wheel. 20 V is applied to the left reel motor and 0 V is applied to the right reel motor, but neither of the reel turntables rotates.

The logic circuits, and the wind and rewind relays receive + 18 V, but the pinch roller solenoid and the brake solenoid receive + 42 V from the rectifier board. The relays and solenoids, however, are energised only when they are grounded (receive a low level) from the logic circuits.

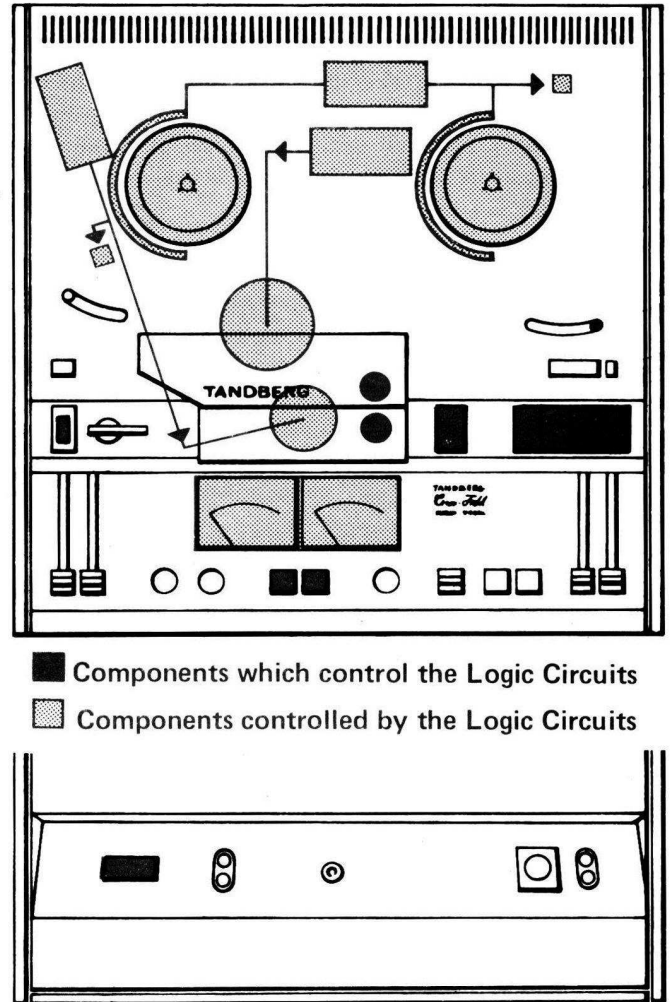

Fig. 2.1

2.2 MODE BUTTONS

A light push on one of the mode buttons gives the logic circuits a short pulse at a low level and engages the required mode.

The RECORD button only gives a low level when a REC SELECT button is depressed.

When one of the mode buttons is pushed while the machine is in the end stop mode (the photo-transistor is illuminated and has a low level on its collector), the new mode will be engaged and the end stop mode cancelled (the photo-transistor is illuminated, but the collector has received a high level from U624D), only as long as the mode button is held down. See also chapter 3 where every mode is explained in detail.

The mode buttons on a remote control unit, which is used to control the tape recorder, operate in the same way as the buttons on the tape deck. If the remote control unit is used with an automatic power timer, an extra switch must be operated on the remote control unit.

2.3 THE END STOP

Tape decks with serial numbers below 2822100 have either a mechanical or a photo-electric end stop. There is a special description about these tape decks in section 3.2.1 in the Service Instruction, preliminary for model 9000X.

Tape decks with serial numbers from 2822100 onwards are fitted with a photo-electric end stop, see Figure 2.2. When the end of the opaque part of the tape (magnetic tape or leader tape) has passed the photo-transistor the machine will go into the stop mode regardless of which mode it was in before.

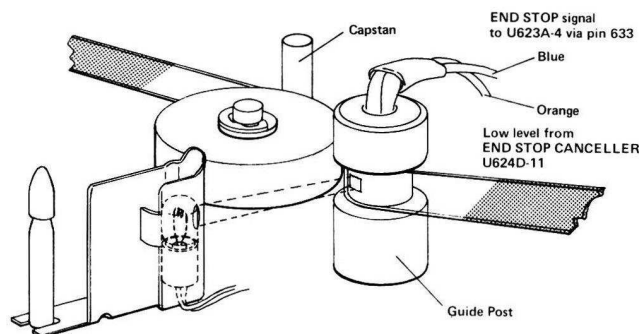

Fig. 2.2 The photo-electric end stop

2.4 THE BRAKE SOLENOID

There is a brake band wrapped round each reel turn turntable and both brake bands are tightened at the same time when the solenoid is energised. In this book this kind of braking is called mechanical braking, while the kind of braking provided by the reel motors is called electrical braking.

2.5 PINCH ROLLER SOLENOID

The pinch roller solenoid is only energised in the record and playback modes. When the pinch roller solenoid is energised the pinch roller is pressed against the capstan and 60 V is applied to the right reel motor through the pinch roller solenoid switch. At the same time the cross-field head is moved up to the record head, and the tape is moved up to the erase, record, and playback heads.

The pinch roller is engaged in two phases by the logic board. First comes the activating phase (pull-in phase) when the pull-in winding on the solenoid receives current at the same time as the hold winding. After about 0.75 seconds, a period corresponding to the pinch roller monostable flip-flop time constant, the hold phase takes over when only the hold winding receives current for as long as either the record or playback mode lasts.

2.6 WIND RELAY AND REWIND RELAY

There is a wind relay and a rewind relay for supplying the reel motors with voltage. Each relay is controlled by its own decoder on the logic board.

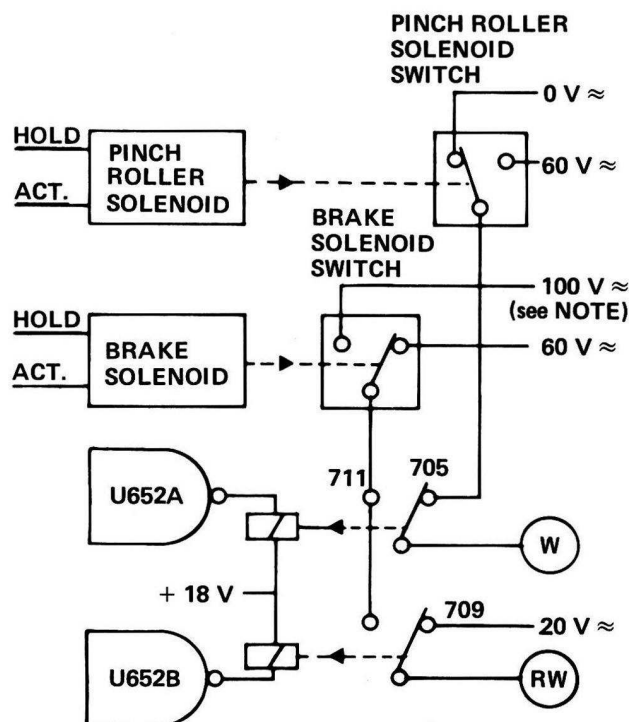

Fig. 2.3 Solenoids and switches

The decoders are controlled by the speed flip-flop and the direction flip-flop. The command signals are sent when one of the mode buttons is pressed. The relays are not energised in the stop mode.

During the wind mode the wind relay supplies 100 V to the right reel motor and during the rewind mode the rewind relay supplies 100 V to the left reel motor.

When the machine is going from WIND to STOP or PLAY the rewind relay is energised and supplies 60 V to the left reel motor which then acts as a brake. At the same time the wind relay removes the 100 V from the right reel motor.

When the machine is going from REWIND to STOP or PLAY, the wind relay is energised and supplies 60 V to the right reel motor which then acts as a brake. At the same time the rewind relay removes the 100 V from the left reel motor.

When the wind relay is energised the WIND button lamp lights, and when the rewind relay is energised the REWIND button lamp lights.

2.7 SPEED AND DIRECTION FLIP-FLOPS (see Figure 2.4).

The two flip-flops U625 B/C and U622B/C are decoders for the direction of tape motion and speed of tape motion (high or low speed). A light push on one of the mode buttons activates both flip-flops at the same time and decides the speed and duration of the tape motion by supplying the relevant output with a high level.

The direction flip-flop has two outputs,

D: Direction forward (play, record, and wind modes).

\bar{D} : Direction backwards (rewind mode)

The speed flip-flop also has two outputs,

S: Speed high (wind and rewind modes)

\bar{S} : Speed low (play and record modes)

By combining 2 of these 4 outputs with 1 of the 4 outputs on the monostable flip-flops the required mode is achieved as the following list of modes shows.

RECORD: $\bar{B} \times D \times \bar{S}$, no braking, forward direction at low speed.

PLAY: $\bar{B} \times D \times \bar{S}$, no braking, forward direction at low speed.

STOP: $\bar{P} \times \bar{D} \times \bar{S}$, no pinch roller, backwards direction at low speed.

END STOP: $\bar{P} \times \bar{D} \times \bar{S}$, no pinch roller, backwards direction at low speed.

WIND: $\bar{B} \times D \times S$, no braking, forward direction at high speed.

REWIND: $\bar{B} \times \bar{D} \times S$, no braking, backwards direction at high speed.

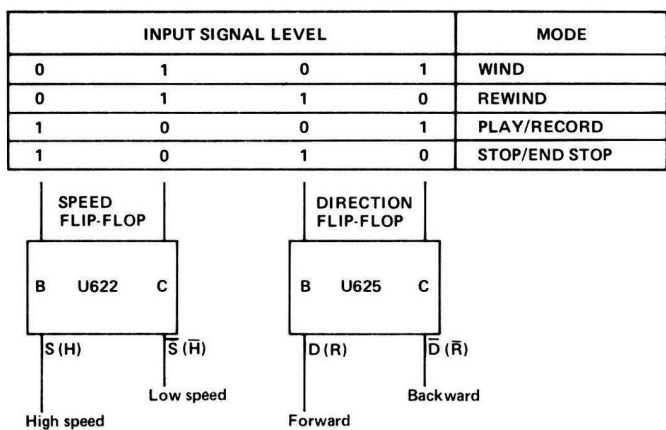

NOTE! (H) and (R) are used on 9000X.

Fig. 2.4 Speed flip-flop and direction flip-flop

2.8 THE METER SWITCH

The meter switch is controlled by the logic board and has several functions:

1. The input signal to the record amplifier is controlled by Q104 and Q204.
2. Both meter lights receive current from Q302, D303 and D305 in playback mode*.
3. The output signal from both playback amplifiers comes through D101 and D201 which are controlled by Q301 and Q302.

* In record mode the meter lights receive current through the REC SELECT switches.

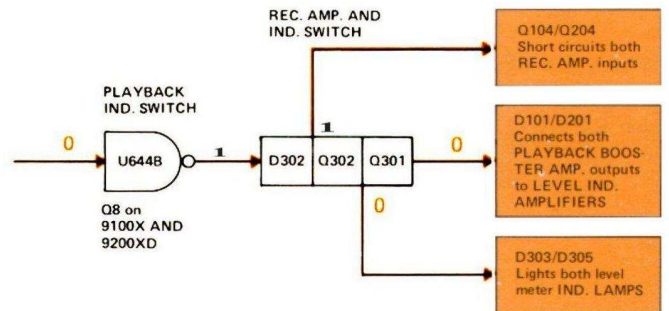

Fig. 2.6 Meter-switch operation during playback

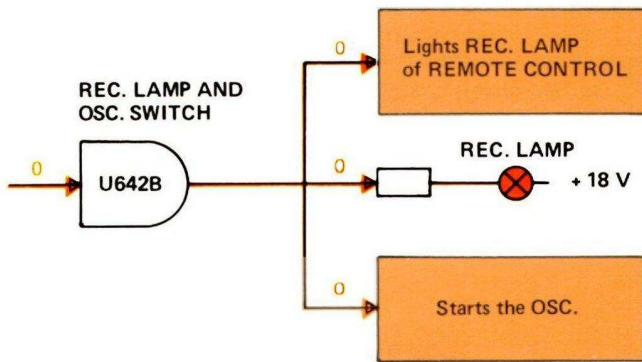

Fig. 2.5 Meter-switch operation during record

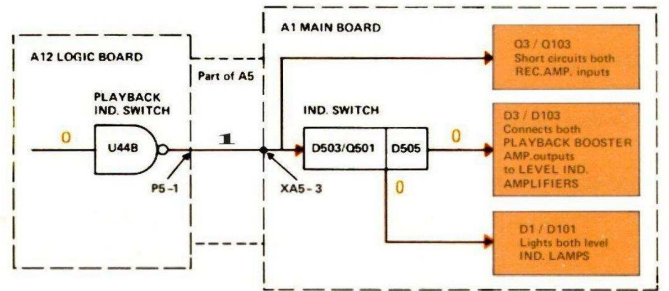

Fig. 2.7 Meter-switch operation during playback, model 9100X and 9200XD

3.0 THE OPERATING MODES

This section is a detailed description of the individual modes; STOP, END STOP, PLAY, RECORD, WIND, and REWIND, together with a description of the modes that can be combined sequentially and the sequence of events that takes place when going from one mode to another mode. These descriptions provide information on all the circuits that are involved when any particular mode is engaged. The path of the trigger pulse through the logic circuit is illustrated on the logic diagram for each of the principal modes. The path of the activating pulse is shown with solid lines while the path of the hold pulse is shown with dotted lines. In section 5 there is a description of the functions of the individual logic circuits.

3.1 THE STOP MODE

The stop mode implies that the brakes are engaged and in the hold phase, so that both reel turntables are stationary. The right reel motor receives 0 V, while the left reel motor receives 20 V from the rewind relay contacts. The stop mode is divided into two parts, normal STOP and END STOP. The difference between these two parts is that when END STOP is in operation the next mode that is required can only be obtained while that particular mode button is held down. The machine must go through the braking sequence to get to STOP or END STOP.

3.1.1 The STOP mode and power switch-on

Power switch-on

When the power is switched on, the R input on U635B is low because capacitor C609 (A12C8 on 9100X/9200XD) between the input of the circuit and ground is discharged. After power switch-on the capacitor charges up rapidly. When the voltage on the capacitor exceeds the 6 to 8 V threshold of the circuit, the brake monostable receives a low triggerpulse (stop pulse) from the circuit output so that the brakes are activated and go over to the hold phase.

STOP lamp

The stop lamp is lit from the brake solenoid energising current and will remain lit as long as either the energising phase or the hold phase lasts. The brightness of the lamp is sharply reduced during the energising phase when both windings on the solenoid are drawing current.

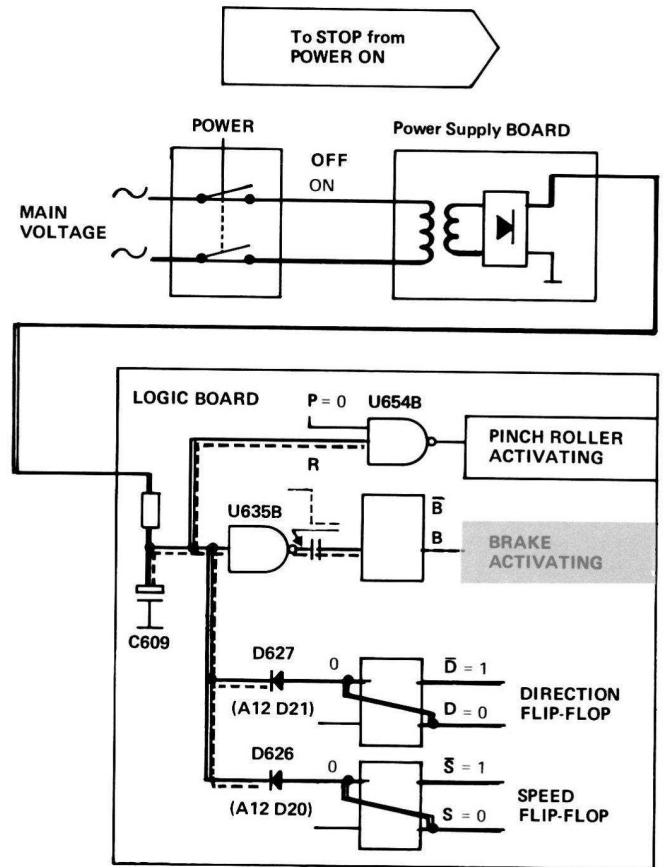

Fig. 3.1 Braking sequence after power switch on

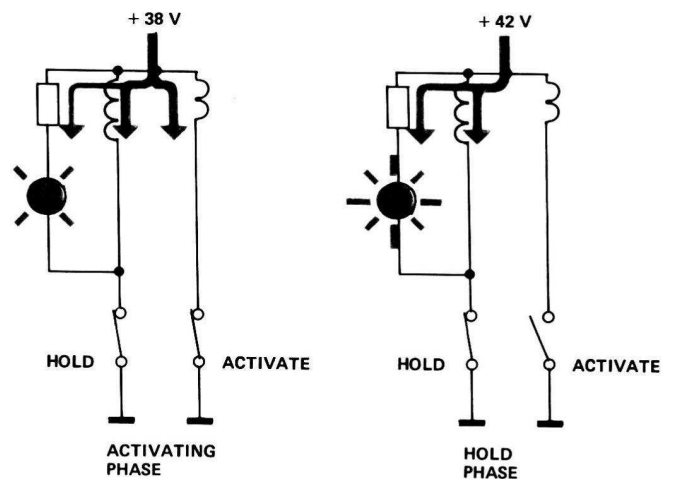

Fig. 3.2 Brightness of the stop lamp during the braking sequence

3.1.2 The STOP mode and power switch-off

Regardless of which mode the machine is in when the power is switched off, the capstan motor and the reel motors will lose their operating voltages and stop. At the same time the hold current to the pinch roller solenoid, brake solenoid, and transfer wheel solenoid will be cut off so that the respective return springs mechanically disengage the pinch roller, and transfer wheel.

The return spring for the armature of the transfer wheel solenoid operates an arm which connects the brakes at the same time as it disconnects the transfer wheel. Regardless of which mode the machine is in when the mains voltage is switched off, it will go into the stop mode and the mechanical brakes will be operated.

The electro-magnetic braking action of the spool motors

The spool motors act as electro-magnetic brakes to achieve two objectives:

- a) During fast winding, playback and record to obtain a particular degree of tape tensioning.

- b) During braking from fast winding to reduce the braking time and increase the braking force. The braking voltage, which is 60 V for both motors, was reduced from 100 V for machines with serial numbers 2829008 onwards..

NOTE! In this book a reference to “case B” a reference to electro-magnetic braking.

When the brake monostable is activated, the brake solenoid switch supplies 60 V braking voltage to the operated wind/rewind relay contact.

During braking from WIND, the rewind decoder gate C causes the rewind relay to be energised. The left reel motor receives 60 V for about 2 seconds.

During braking from REWIND, the wind decoder gate B causes the wind relay to be energised. The right reel motor receives 60 V for about 2 seconds.

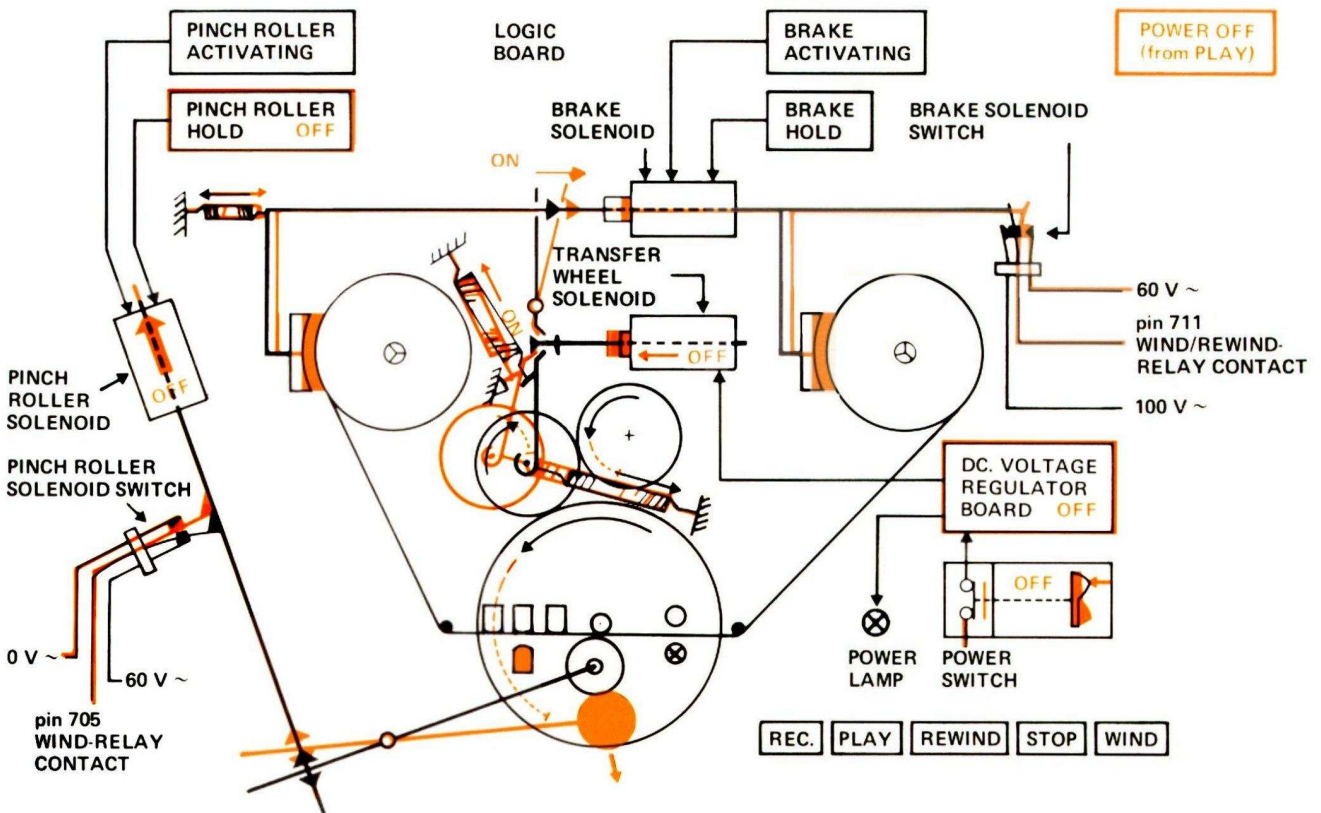

Fig. 3.3 Power off, from PLAY

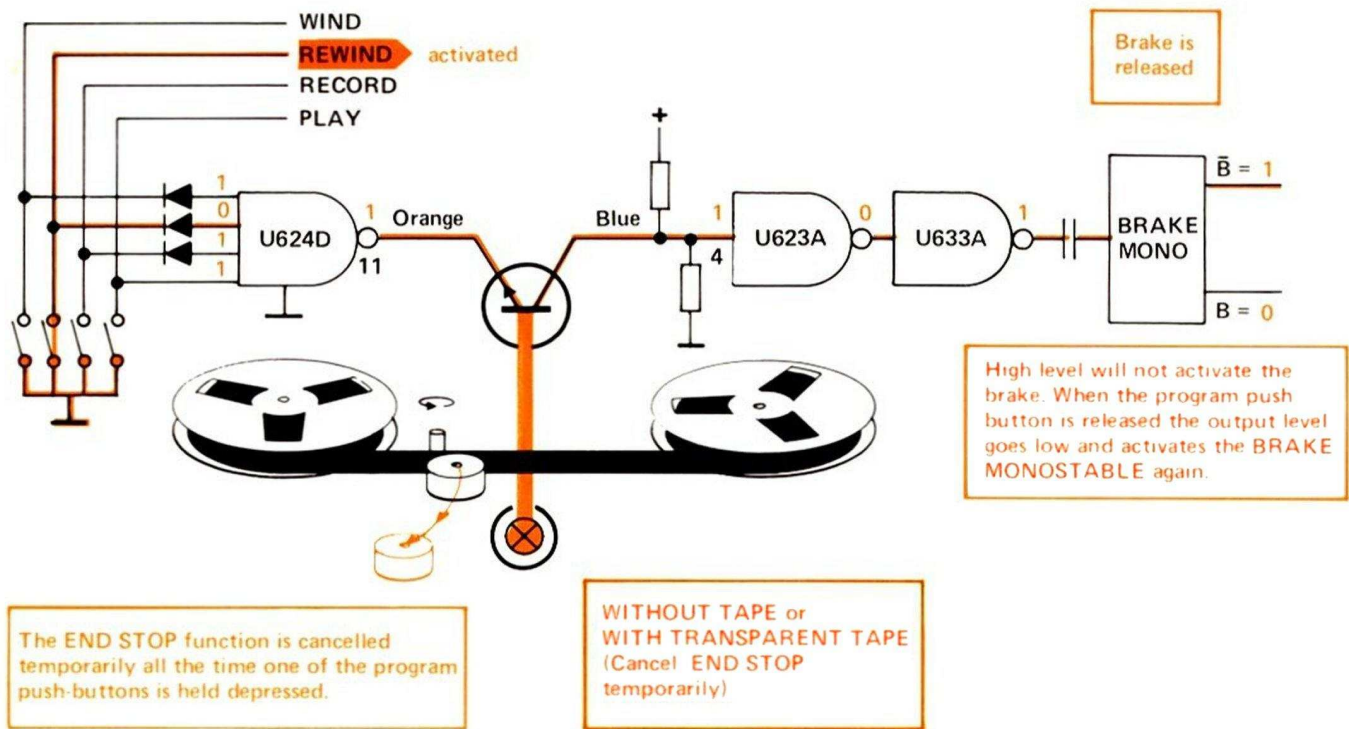

Fig. 3.5 The end stop mode is suspended while a mode button is held depressed.

3.1.4 Cancelling end stop

The end stop facility can be cancelled by preventing light from falling on the photo-transistor. Opaque tape (magnetic tape or leader tape) will cause the transistor to be cut-off and the collector will receive a high level from U623A as a result of resistors R602 and R634 (A12R2 and A12R3 on 9100X/9100XD).

3.2 PLAYBACK

In the play mode the pinch roller engages and goes over to hold so that it can transport the tape all the time the machine is in the play mode. At the same time, the pinch roller solenoid operates the pinch roller solenoid switch and 60 V is applied to the right reel motor while 20 V is applied to the left reel motor. Neither the wind relay nor the rewind relay is engaged. The brakes are released at the same instant as the pinch roller is engaged. The play lamp lights as long as the pinch roller is engaged.

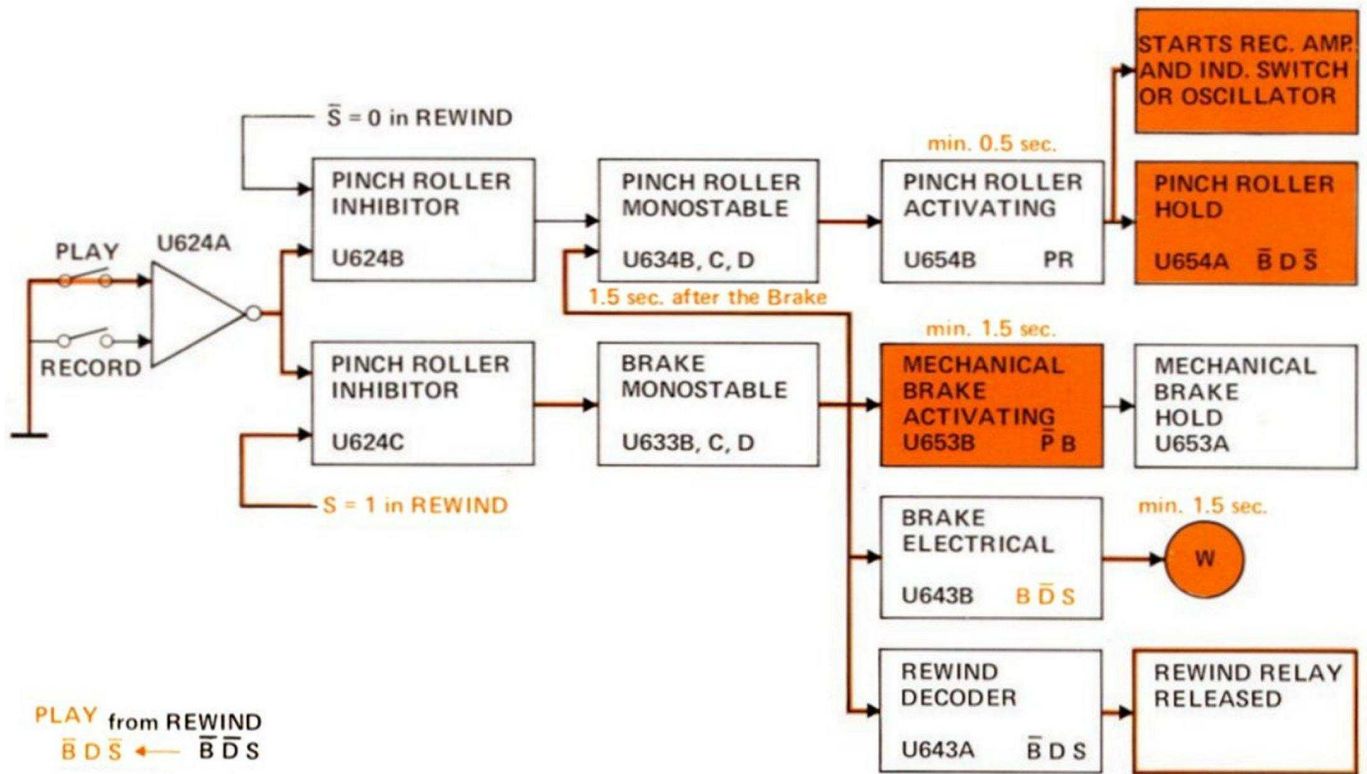

Fig. 3.7 PLAY from REWIND

3.2.2 To PLAY from REWIND

Look at Figure 3.9 when you read this description. In the rewind mode 100 V is applied to the left reel motor while the right reel motor receives 0 V. The 100 V comes from the un-operated brake solenoid switch through the closed rewind relay contacts. The relay is energised from the rewind decoder gate U643A when the three inputs B, D, and S have a high level.

When the PLAY button is pressed, the M output on the play and rec. memory goes high and remembers the PLAY instruction (the same as when going to PLAY from STOP). Since the machine is still in the rewind mode the S input is high so that the PLAY instruction is now routed through the pinch roller inhibitor gate U624C and this signal activates the brake monostable (see Figure 5.4).

The B output of the brake monostable goes high and operates the mechanical brake through the brake solenoid and the electrical brake (right reel motor) through the wind relay contacts. The wind relay is energised by the wind decoder gate U643B as long as the three inputs to the gate D x B x S have a high level. The right reel motor receives 60 V braking voltage.

3.2.3 To PLAY from WIND

The sequence of operation when the machine goes to PLAY from WIND is almost the same as when it goes to PLAY from REWIND. The electromagnetic brake operates in another way. When the machine is in the wind mode, the right reel motor receives 100 V and the left motor receives 20 V hold back voltage, the wind relay is energised by the wind decoder gate U644C and inputs B, D, and S are high.

When the B output on the brake monostable goes high, the wind relay releases (input B on U644C goes low) and the rewind relay is energised. Inputs B, D, and S on the rewind decoder U643C are high. In the braking phase the right reel motor receives 0 V and the left reel motor receives 60 V braking voltage.

The rest of the sequence of operations concerns the machine as it goes into the play mode and is the same as that described in section 3.2.1.

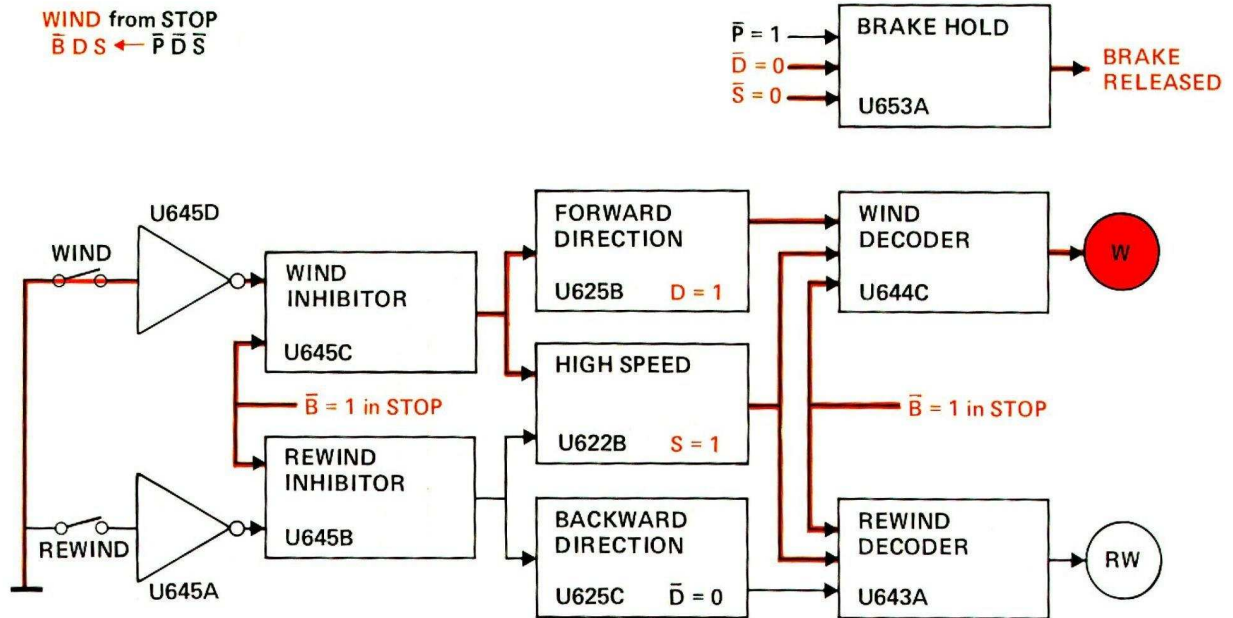

Fig. 3.8 WIND from STOP

3.3 THE RECORD MODE

The differences between the play and record modes are that the record mode can only be engaged from STOP and in the record mode the record decoder gate is activated instead of the play decoder gate. See the explanation of the pinch roller operation in section 3.2.1.

One of the REC. SELECT buttons must be depressed before the logic circuits can receive a low level when the RECORD button is pressed. When one of the REC' SELECT buttons is depressed the meter lamp for the respective channel will be grounded and the lamp will light.

The play/record memory and the play/record flip-flop will be triggered by a low pulse from the output of the record inhibitor gate. The output goes low because inputs D and S have a high level from STOP.

Going out of the RECORD mode

When any mode buttons, other than RECORD, is pressed the play/record flip-flop will disconnect the record lamp and the oscillator through the record decoder circuit. At the same time the pinch roller is disengaged because the B, and D or S inputs on the pinch roller hold gate receive a low level.

3.4 WIND

The wind mode can be engaged from any of the other modes.

When the wind mode is engaged, the direction flip-flop and the speed flip-flop ensure that the other modes are disengaged, since it is only in the wind mode that the D output on the direction flip-flop and the S output on the speed flip-flop are high. In the wind mode the wind lamp and the wind relay are operated by the wind relay hold gate. The right reel motor receives 100 V and the left reel motor receives 20 V hold back voltage.

NOTE! The wind and rewind modes cannot be engaged when the machine is braking.

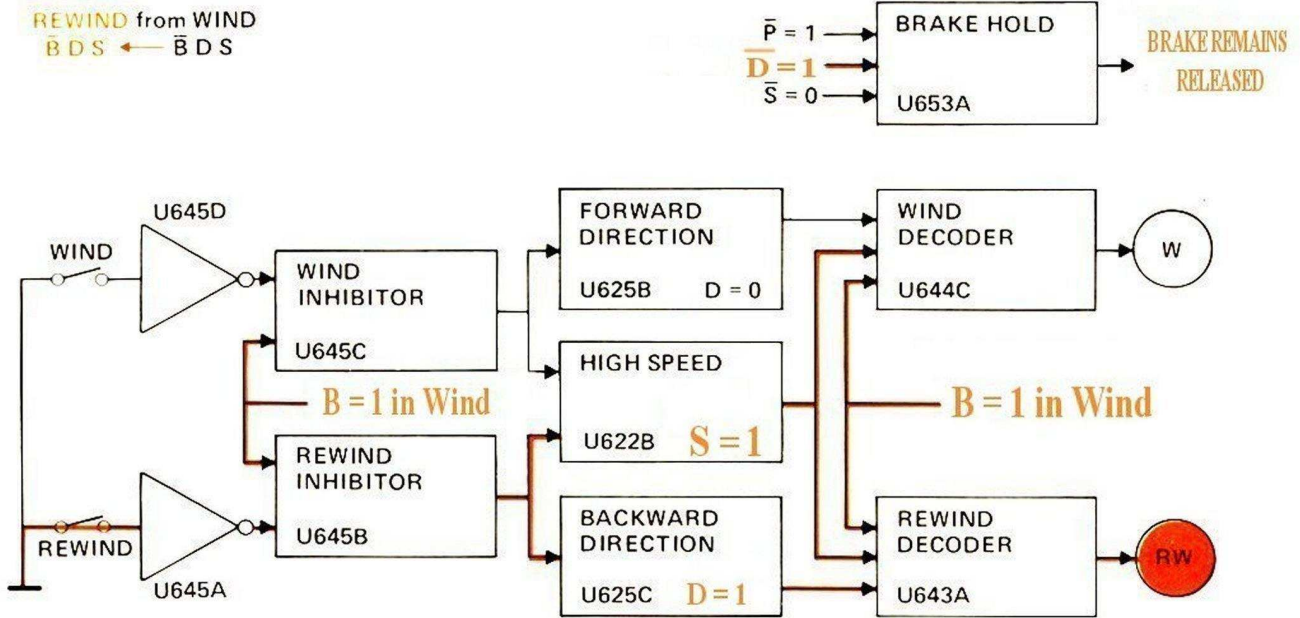

Fig. 3.9 REWIND from WIND

3.5.1 To WIND from REWIND

When the machine goes from WIND to REWIND the motor voltages change. The direction flip-flop is high in the WIND mode and high in the REWIND REWIND mode. The S output on the speed flip-flop remains high since in both modes the motors are operating at high speed without brakes.

3.5.2 From WIND to REWIND

When the WIND button is pressed the D output goes high while the S and B outputs remain high. When the wind decoder inputs D, S and B on U644C go high, the wind relay is energised. The right reel motor receives 100 V from the brake solenoid switch.

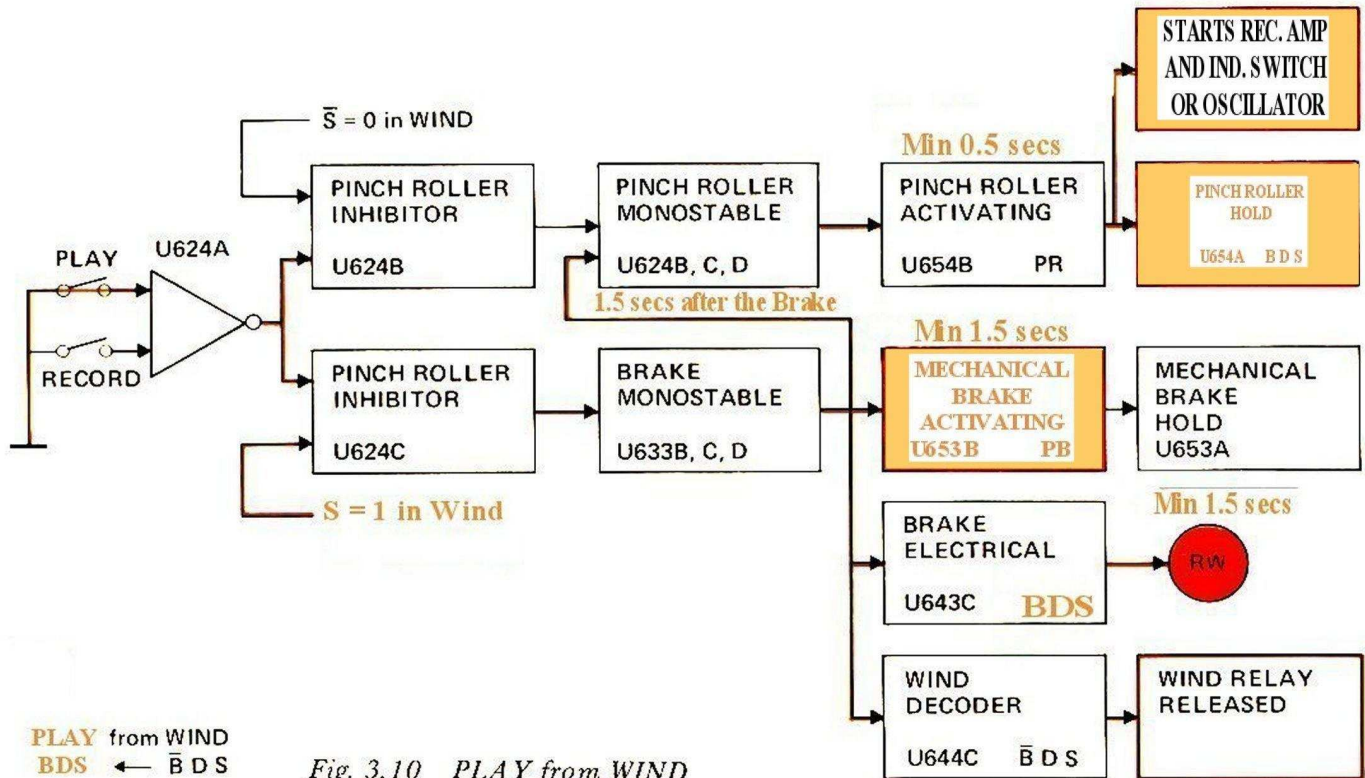
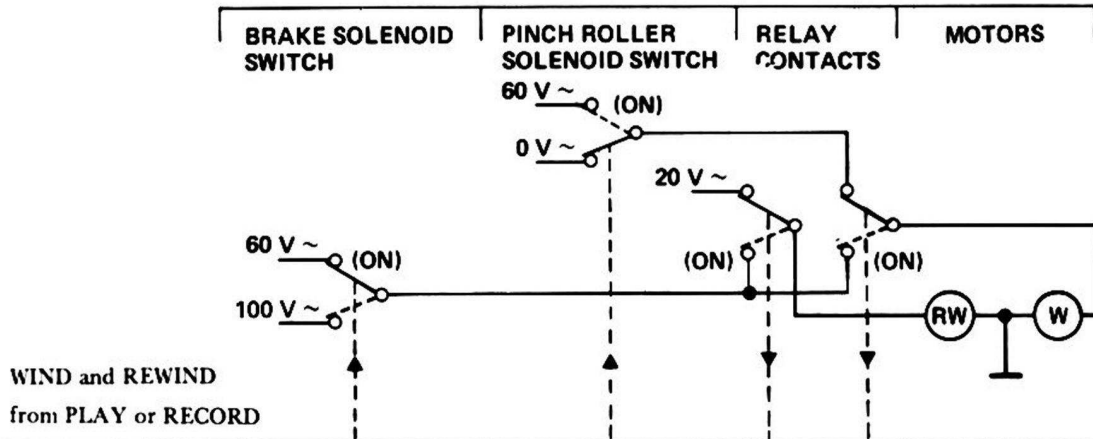

Fig. 3.10 PLAY from WIND

TABLE OF OPERATING SEQUENCES

This table presents in condensed form the sequence of operations when each mode is engaged.



Sequence	BRAKE		PINCH ROLLER		RELAY		MOTOR	
	ACTIVATE	HOLD	ACTIVATE	HOLD	RW	W	RW	W
1. PLAY/RECORD	—	—	—	ON	—	—	20 V	60 V
2. WIND	—	—	—	—	—	ON	20 V	100 V
3. REWIND	—	—	—	—	ON	—	100 V	0 V

STOP from PLAY or RECORD

Sequence	BRAKE		PINCH ROLLER		RELAY		MOTOR	
	ACTIVATE	HOLD	ACTIVATE	HOLD	RW	W	RW	W
1. PLAY/RECORD	—	—	—	ON	—	—	20 V	60 V
2. Brake activating	ON 1.5 sec.	—	—	—	—	—	20 V	0 V
3. Brake hold (STOP)	—	ON	—	—	—	—	20 V	0 V

STOP from WIND

Sequence	BRAKE		PINCH ROLLER		RELAY		MOTOR	
	ACTIVATE	HOLD	ACTIVATE	HOLD	RW	W	RW	W
1. WIND	—	—	—	—	—	ON	20 V	100 V
2. Brake activating	ON 1.5 sec.	—	—	—	ON	—	60 V	0 V
3. Brake hold (STOP)	—	ON	—	—	—	—	20 V	0 V

STOP from REWIND

Sequence	BRAKE		PINCH ROLLER		RELAY		MOTOR	
	ACTIVATE	HOLD	ACTIVATE	HOLD	RW	W	RW	W
1. REWIND	—	—	—	—	ON	—	100 V	0 V
2. Brake activating	ON 1.5 sec.	—	—	—	—	ON	20 V	60 V
3. Brake hold (STOP)	—	ON	—	—	—	—	20 V	0 V

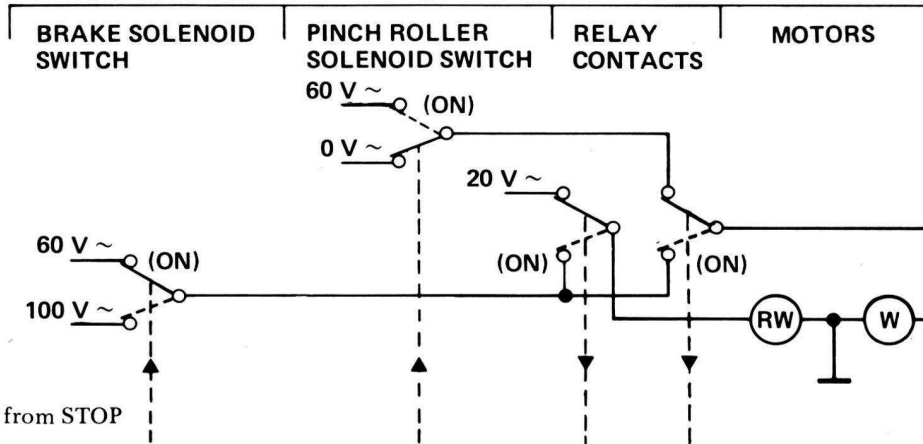

RECORD or PLAY from STOP

Sequence	BRAKE		PINCH ROLLER		RELAY		MOTOR	
	ACTIVATE	HOLD	ACTIVATE	HOLD	RW	W	RW	W
1. STOP	—	ON	—	—	—	—	20 V	0 V
2. PLAY activating	—	—	ON 0.75 sec.	—	—	—	20 V	60 V
3. PLAY hold	—	—	—	ON	—	—	20 V	60 V

WIND from STOP

Sequence	BRAKE		PINCH ROLLER		RELAY		MOTOR	
	ACTIVATE	HOLD	ACTIVATE	HOLD	RW	W	RW	W
1. STOP	—	ON	—	—	—	—	20 V	0 V
2. WIND	—	—	—	—	—	ON	20 V	100 V

REWIND from STOP

Sequence	BRAKE		PINCH ROLLER		RELAY		MOTOR	
	ACTIVATE	HOLD	ACTIVATE	HOLD	RW	W	RW	W
1. STOP	—	ON	—	—	—	—	20 V	0 V
2. REWIND	—	—	—	—	ON	—	100 V	0 V

PLAY from WIND

Sequence	BRAKE		PINCH ROLLER		RELAY		MOTOR	
	ACTIVATE	HOLD	ACTIVATE	HOLD	RW	W	RW	W
1. WIND	—	—	—	—	—	ON	20 V	100 V
2. Brake activating	ON 3.5 sec.	—	—	—	ON	—	60 V	0 V
3. PLAY activating	—	—	ON 0.75 sec.	—	—	—	20 V	60 V
4. PLAY hold	—	—	—	ON	—	—	20 V	60 V

PLAY from REWIND

Sequence	BRAKE		PINCH ROLLER		RELAY		MOTOR	
	ACTIVATE	HOLD	ACTIVATE	HOLD	RW	W	RW	W
1. REWIND	—	—	—	—	ON	—	100 V	0 V
2. Brake activating	ON 3.5 sec.	—	—	—	—	ON	20 V	60 V
3. PLAY activating	—	—	ON 0.75 sec.	—	—	—	20 V	60 V
4. PLAY hold	—	—	—	ON	—	—	20 V	60 V

REWIND from WIND

Sequence	BRAKE		PINCH ROLLER		RELAY		MOTOR	
	ACTIVATE	HOLD	ACTIVATE	HOLD	RW	W	RW	W
1. WIND	—	—	—	—	—	ON	20 V	100 V
2. REWIND	—	—	—	—	ON	—	100 V	0 V

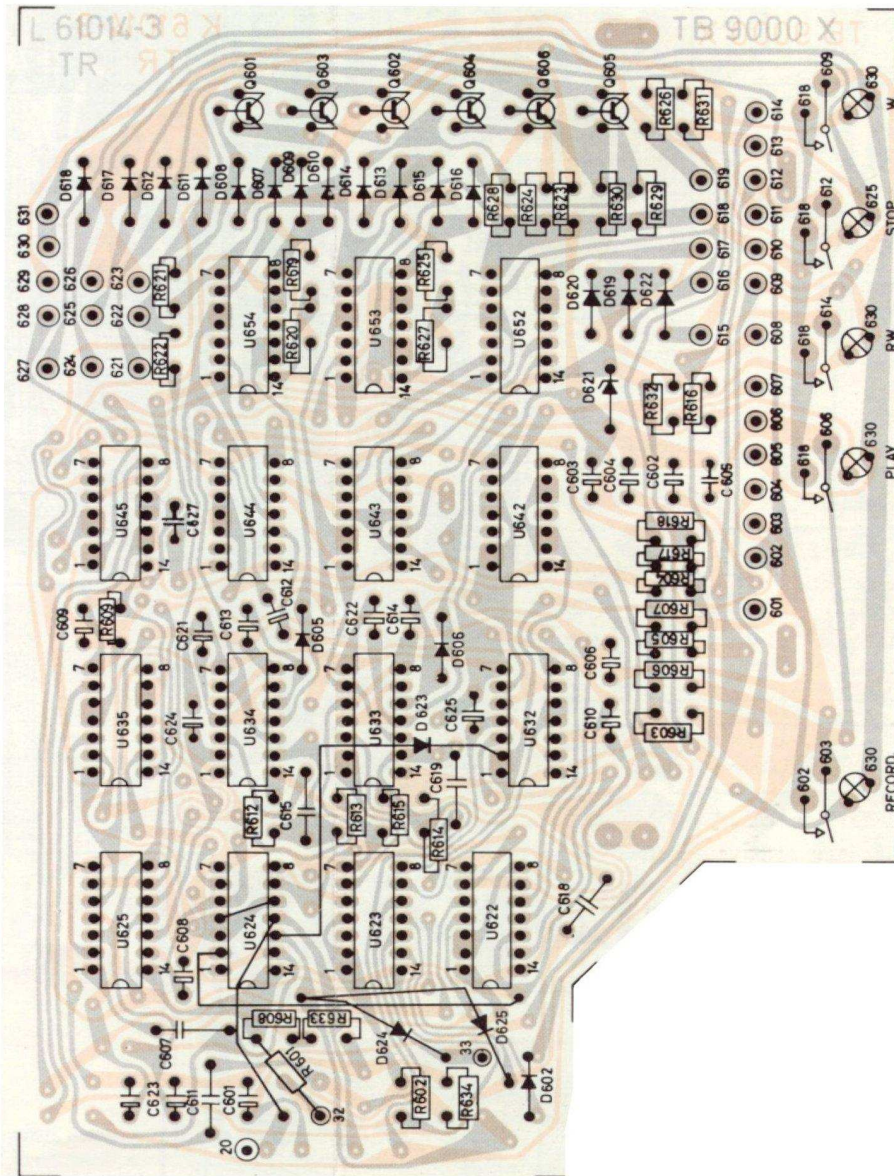

**BOARD FOR FUNCTION CONTROL LOGIC.
SEEN FROM SOLDER SIDE.
MODEL 9000X**

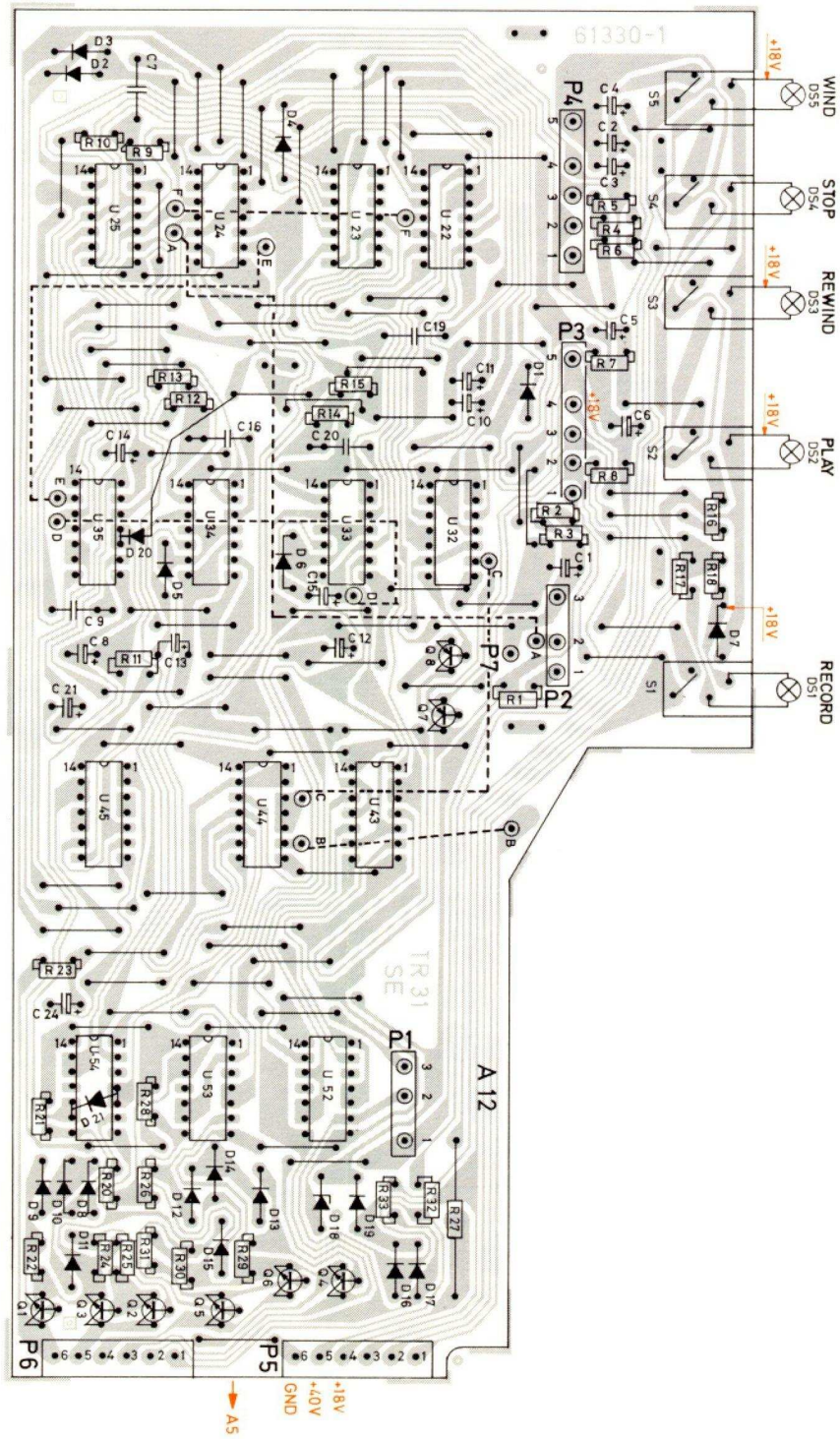

**BOARD FOR FUNCTION CONTROL LOGIC.
SEEN FROM SOLDER SIDE.
MODEL 9100X AND 9200XD**

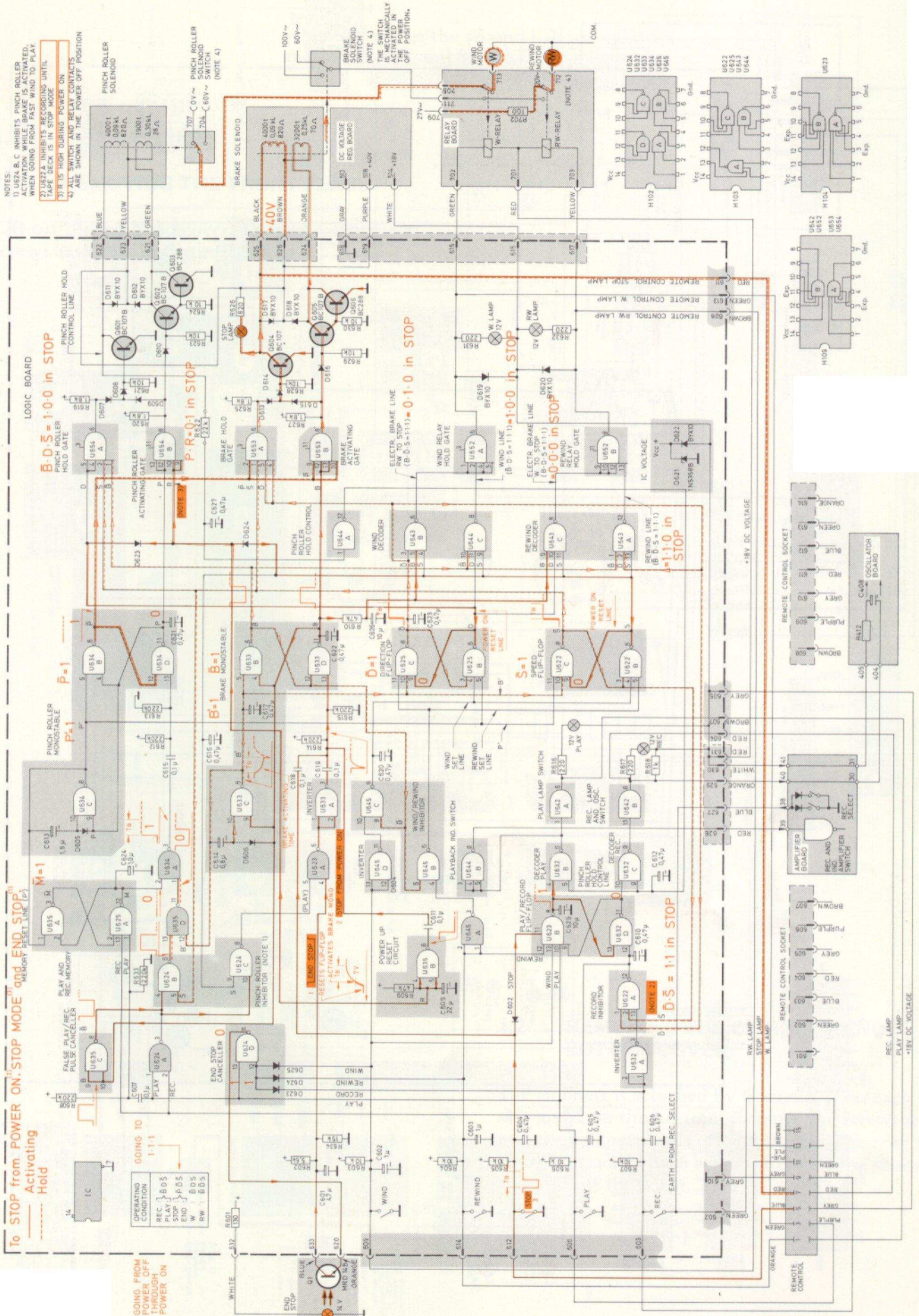

NOTES:
 1) U1, U2, U3, U4 INHIBITS PINCH ROLLER HOLD LINE WHEN GOING FROM PLAY TO STOP.
 2) U12, U13 INHIBITS RECORDING UNTIL TAPE DECK IS IN STOP MODE.
 3) U14'S HIGH DURING POWER ON.
 4) U15'S HIGH DURING POWER ON.
 5) U16'S HIGH DURING POWER ON.
 6) U17'S HIGH DURING POWER ON.
 7) U18'S HIGH DURING POWER ON.
 8) U19'S HIGH DURING POWER ON.
 9) U20'S HIGH DURING POWER ON.
 10) U21'S HIGH DURING POWER ON.
 11) U22'S HIGH DURING POWER ON.
 12) U23'S HIGH DURING POWER ON.
 13) U24'S HIGH DURING POWER ON.
 14) U25'S HIGH DURING POWER ON.
 15) U26'S HIGH DURING POWER ON.
 16) U27'S HIGH DURING POWER ON.
 17) U28'S HIGH DURING POWER ON.
 18) U29'S HIGH DURING POWER ON.
 19) U30'S HIGH DURING POWER ON.
 20) U31'S HIGH DURING POWER ON.
 21) U32'S HIGH DURING POWER ON.
 22) U33'S HIGH DURING POWER ON.
 23) U34'S HIGH DURING POWER ON.
 24) U35'S HIGH DURING POWER ON.
 25) U36'S HIGH DURING POWER ON.
 26) U37'S HIGH DURING POWER ON.
 27) U38'S HIGH DURING POWER ON.
 28) U39'S HIGH DURING POWER ON.
 29) U40'S HIGH DURING POWER ON.
 30) U41'S HIGH DURING POWER ON.
 31) U42'S HIGH DURING POWER ON.
 32) U43'S HIGH DURING POWER ON.
 33) U44'S HIGH DURING POWER ON.
 34) U45'S HIGH DURING POWER ON.
 35) U46'S HIGH DURING POWER ON.
 36) U47'S HIGH DURING POWER ON.
 37) U48'S HIGH DURING POWER ON.
 38) U49'S HIGH DURING POWER ON.
 39) U50'S HIGH DURING POWER ON.
 40) U51'S HIGH DURING POWER ON.
 41) U52'S HIGH DURING POWER ON.
 42) U53'S HIGH DURING POWER ON.
 43) U54'S HIGH DURING POWER ON.
 44) U55'S HIGH DURING POWER ON.
 45) U56'S HIGH DURING POWER ON.
 46) U57'S HIGH DURING POWER ON.
 47) U58'S HIGH DURING POWER ON.
 48) U59'S HIGH DURING POWER ON.
 49) U60'S HIGH DURING POWER ON.
 50) U61'S HIGH DURING POWER ON.
 51) U62'S HIGH DURING POWER ON.
 52) U63'S HIGH DURING POWER ON.
 53) U64'S HIGH DURING POWER ON.
 54) U65'S HIGH DURING POWER ON.
 55) U66'S HIGH DURING POWER ON.
 56) U67'S HIGH DURING POWER ON.
 57) U68'S HIGH DURING POWER ON.
 58) U69'S HIGH DURING POWER ON.
 59) U70'S HIGH DURING POWER ON.
 60) U71'S HIGH DURING POWER ON.
 61) U72'S HIGH DURING POWER ON.
 62) U73'S HIGH DURING POWER ON.
 63) U74'S HIGH DURING POWER ON.
 64) U75'S HIGH DURING POWER ON.
 65) U76'S HIGH DURING POWER ON.
 66) U77'S HIGH DURING POWER ON.
 67) U78'S HIGH DURING POWER ON.
 68) U79'S HIGH DURING POWER ON.
 69) U80'S HIGH DURING POWER ON.
 70) U81'S HIGH DURING POWER ON.
 71) U82'S HIGH DURING POWER ON.
 72) U83'S HIGH DURING POWER ON.
 73) U84'S HIGH DURING POWER ON.
 74) U85'S HIGH DURING POWER ON.
 75) U86'S HIGH DURING POWER ON.
 76) U87'S HIGH DURING POWER ON.
 77) U88'S HIGH DURING POWER ON.
 78) U89'S HIGH DURING POWER ON.
 79) U90'S HIGH DURING POWER ON.
 80) U91'S HIGH DURING POWER ON.
 81) U92'S HIGH DURING POWER ON.
 82) U93'S HIGH DURING POWER ON.
 83) U94'S HIGH DURING POWER ON.
 84) U95'S HIGH DURING POWER ON.
 85) U96'S HIGH DURING POWER ON.
 86) U97'S HIGH DURING POWER ON.
 87) U98'S HIGH DURING POWER ON.
 88) U99'S HIGH DURING POWER ON.
 90) U100'S HIGH DURING POWER ON.

THE SIGNAL PATH TO STOP FROM POWER ON.

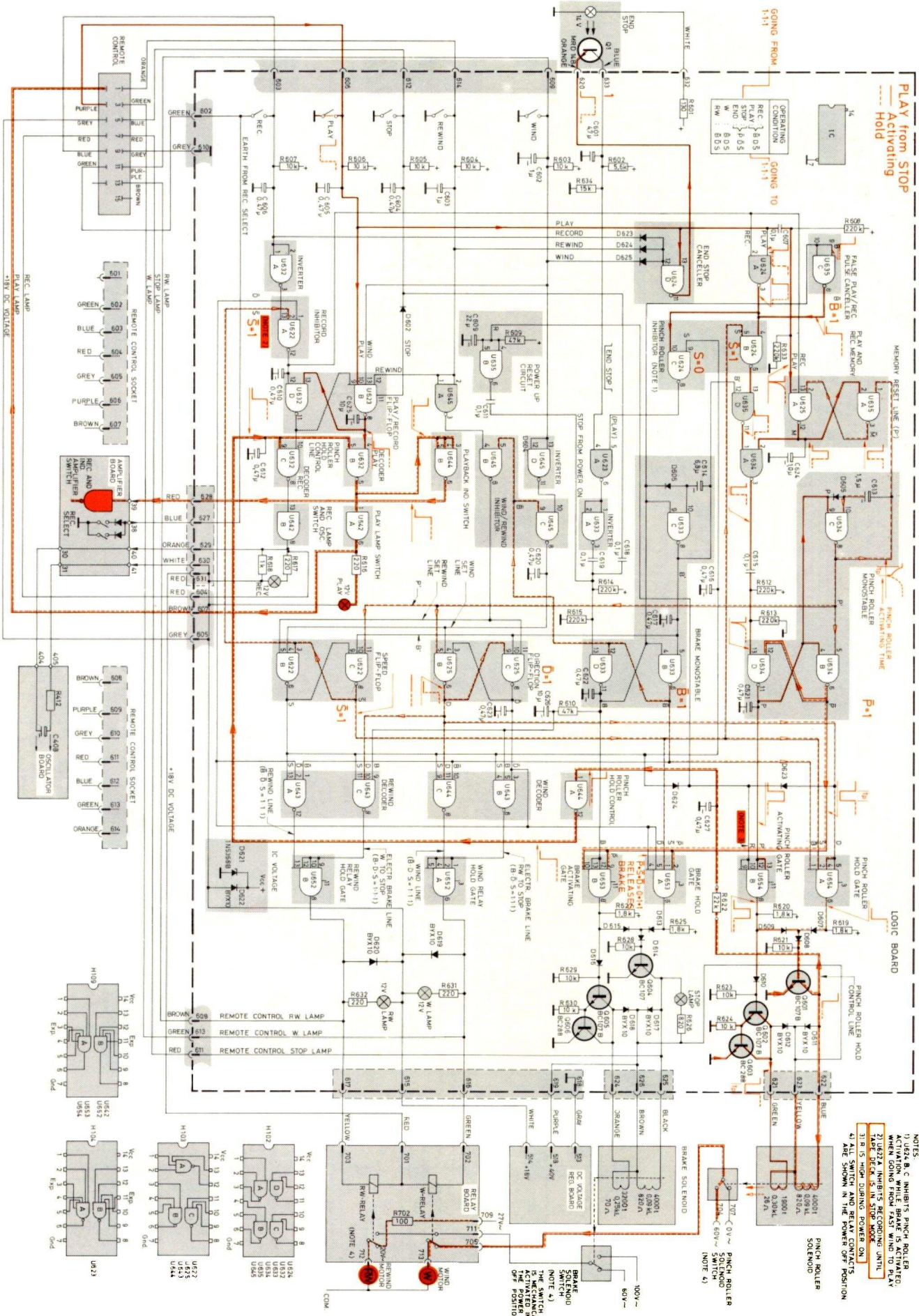

PLAY FROM STOP
Activating

MEMORY RESET LINE (P1)

LOGIC BOARD

- NOTES:
- 1) U624 B,C INHIBITS PINCH ROLLER ACTIVATION WHILE BRAKE IS ACTIVATED. WHEN GOING FROM REWIND TO PLAY, U624 INHIBITS STOP WORK UNTIL U624 IS HIGH DURING POWER ON.
 - 2) U624 INHIBITS STOP WORK UNTIL U624 IS HIGH DURING POWER ON.
 - 3) U624 IS HIGH DURING POWER ON.
 - 4) ALL SWITCH AND RELAY CONTACTS ARE SHOWN IN THE POWER OFF POSITION.

100V~
80V~

THE SIGNAL PATH TO PLAY FROM STOP.

MECHANICAL AND ELECTRICAL ADJUSTMENTS.

All paragraphs in the second half are valid for models 9100X and 9200XD.

1. DISMANTLING

1.1 REMOVING THE FRONT PLATE

Lift off the top head cover. Then unscrew the 8 screws as shown in Figure 1.1.

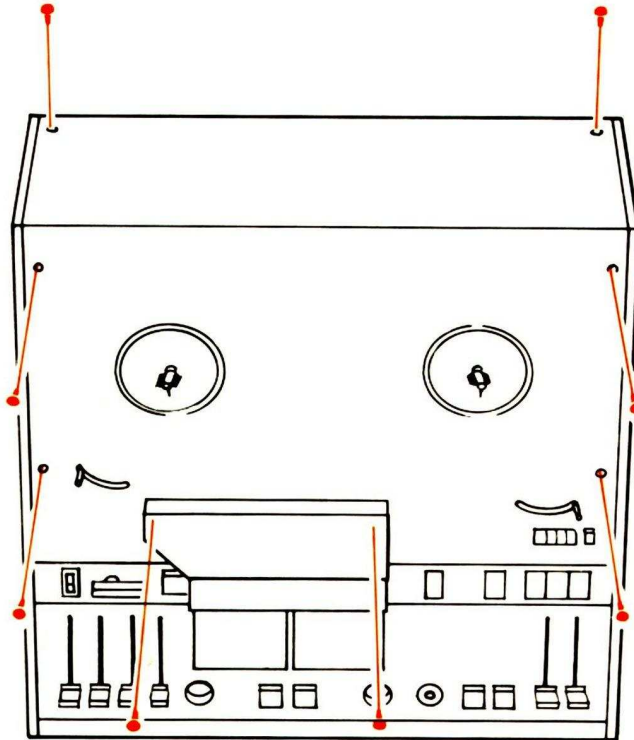

Fig. 1.1 The screws for the front plate.

1.2 REMOVING THE CABINETT AND BOTTOM COVER

The cabinett is attached by 6 screws, 2 on each side and 2 on the bottom. Remove the screws and pull the cabinett walls off the chassis. The rear cover is attached by 6 screws. Remove the screws and pull off the cover.

2.0 REGULAR MAINTENANCE

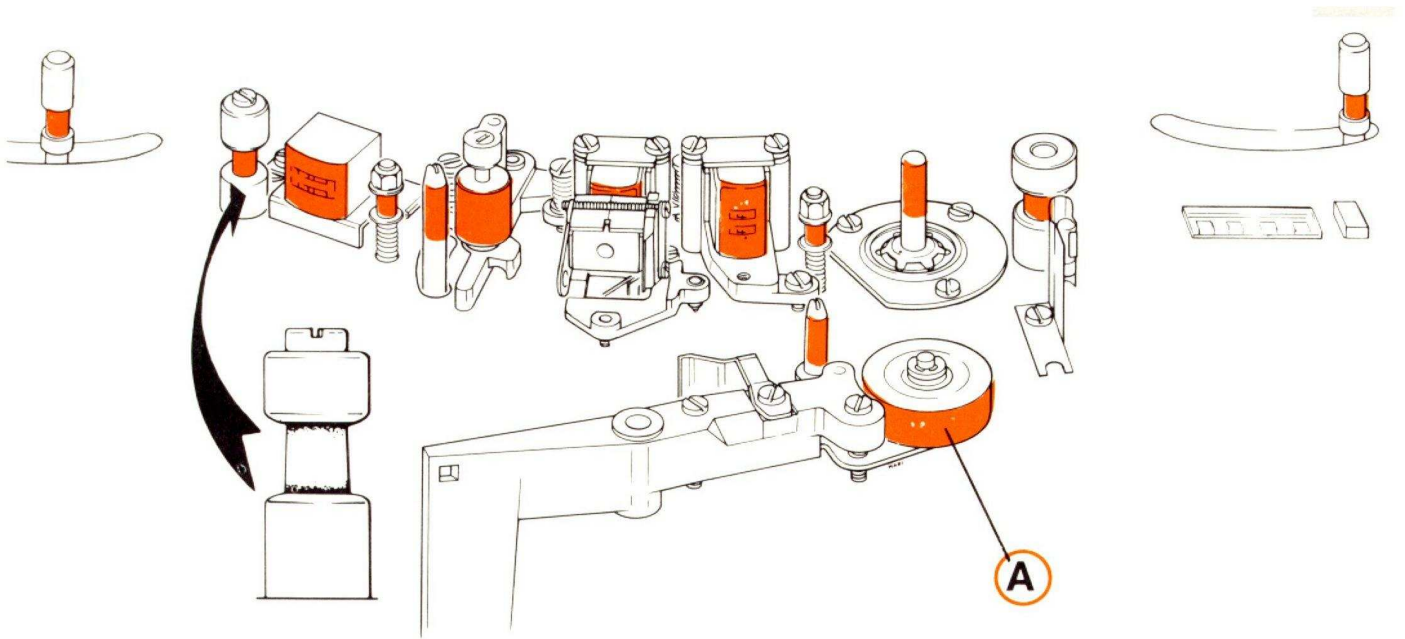

Fig. 2.1 Where to clean

2.1 CLEANING THE HEADS

The parts of the tape deck that are in contact with the tape surface should be cleaned regularly, otherwise the sound quality will be greatly reduced. See Figure 2.1

If the tape deck is used every day, cleaning should be performed at least once a week. A good time to clean is just before making an important recording.

Cleaning the capstan and pinch roller is important to avoid wow and flutter. The pinch roller, Figure 2.1-A needs to be cleaned only if the tape motion is uneven or if there are visible deposits on the roller. Four to six times a year should be satisfactory.

The cleaning can be done with Q-tips or a piece of flannel wrapped around a small stick and moistened with pure alcohol or methylated spirit. A kit intended for this purpose "Tandberg Professional Tape Head Cleaner" is available.

NOTE! Do not use solvents, such as acetone or trichlorethylene, as these may damage the heads. Do not use metal objects for cleaning.

Cleaning should be performed both before and after adjustments.

How to clean:

1. Remove the head covers.
2. Clean the front of the tape heads and the tape guides. (The spots indicated in colour on Figure 2.1).
3. Check the surrounding area for dust and deposits from the tape clean if required.
4. Do not use any sharp objects when cleaning. Do not touch the adjustment-screws.

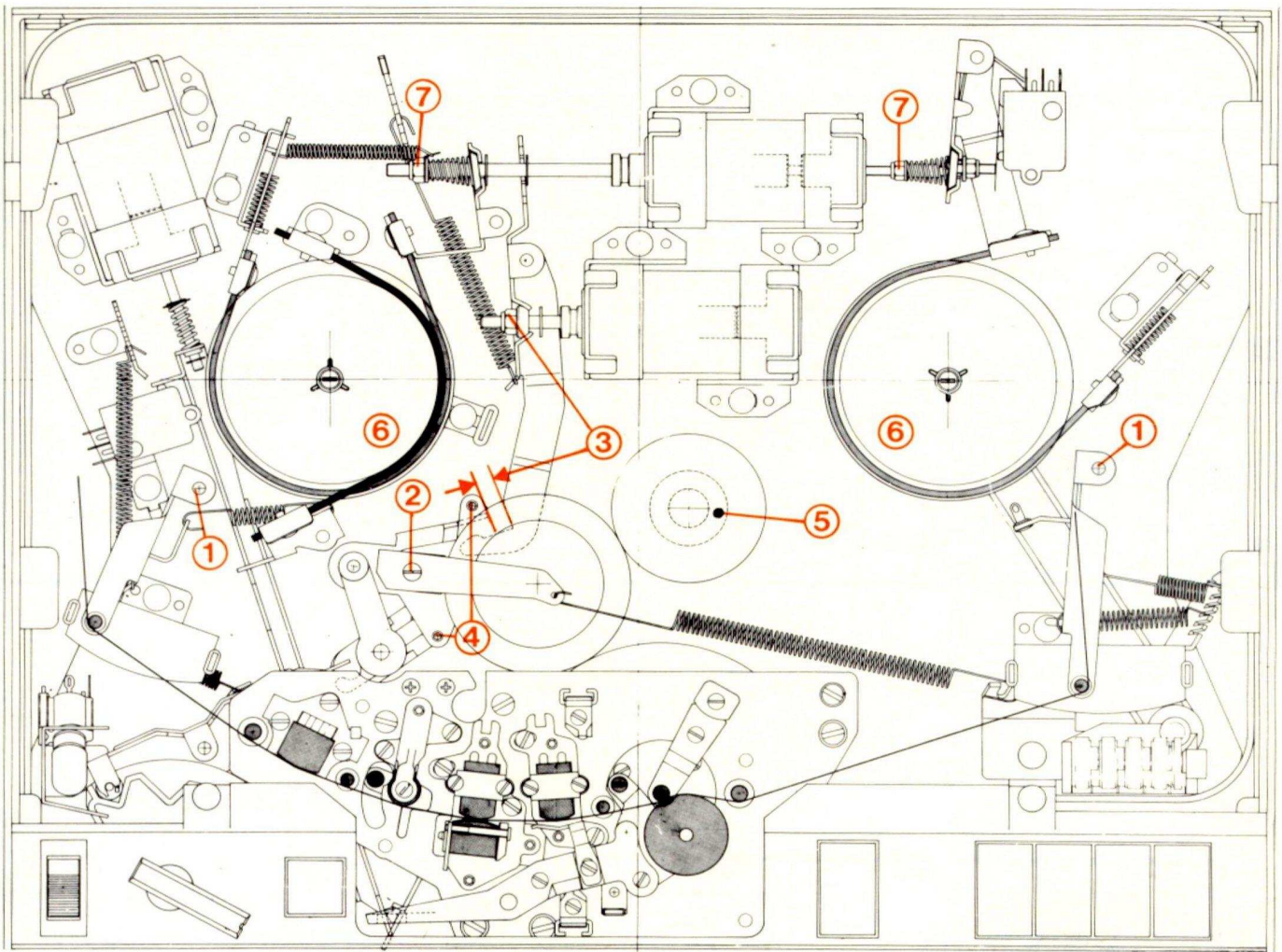

Fig. 3.1 The mechanical parts with adjustment points

3.0 MECHANICAL SERVICING

3.1 MECHANICAL ADJUSTMENTS, SEE FIGURE 3.

1. Height adjustment of the tape tension arms.
2. End thrust adjustment of the speed transfer wheel. Adjust the screw to achieve a light end thrust of 10 to 100 g on the wheel. The speed transfer wheel shall not have any axial play.
3. Power on. Adjust gap to 1.5 to 3 mm with the nut on the speed transfer wheel-solenoid.
4. Position adjustment of the speed transfer wheel. The speed transfer wheel should be parallel with the motor pulley and the flywheel.
5. Allen screw for the motor pulley.
6. Turntables and reel motors, see page 29.
7. Power off. Adjustment nuts for the braking force, see page 28.

2.3 LUBRICATION

The reel motors may require lubrication from time to time. The interval between each lubrication should be at least 3000 hours of operation.

Use DTE Mobil oil (or equiv.), and only one drop of oil for each motor.

The capstan motor need no lubrication.

The speed transfer wheel and pinch roller and the flywheel are mounted in self-lubricating bearings and should under normal conditions not need any attention. If for some reason lubrication appears to be necessary, use Teresso oil No. 43 or 47 from Esso, (or equiv.).

2.2 DEGAUSSING

A marked increase in background noise from the tape may indicate that the heads or other parts in the tape path should have residual magnetism removed (degaussing).

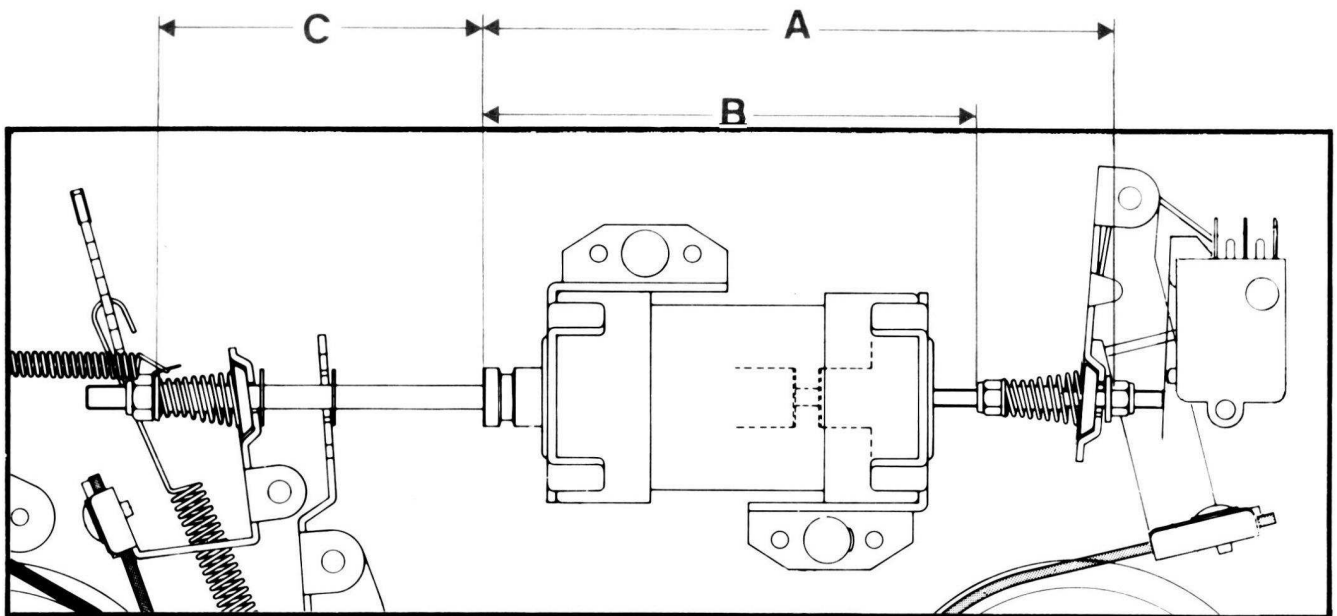

Fig. 3.2 The brake solenoid

3.2 SOLENOIDS BRAKE SOLENOID, SEE FIGURE 3.2

Power off. Check with a pair of callipers the distances A and B and C, according to the following table:

A	– 105 mm
B	– 80 mm
C	– 60 mm

Adjust the nuts if necessary and the brake force should be correct.

NOTE! When exchanging the brake solenoid, adjust the nuts as described.

3.3 PINCH ROLLER SOLENOID, SEE FIGURE 3.3

Power on and the deck in PLAY. The gap should be 0.5 to 2.0 mm, and if necessary adjust with the screws marked with X in Figure 3.3.

NOTE! Before installing a new solenoid, make sure that transistor BC288 (Q3–Q6) on the logic board is not shorted.

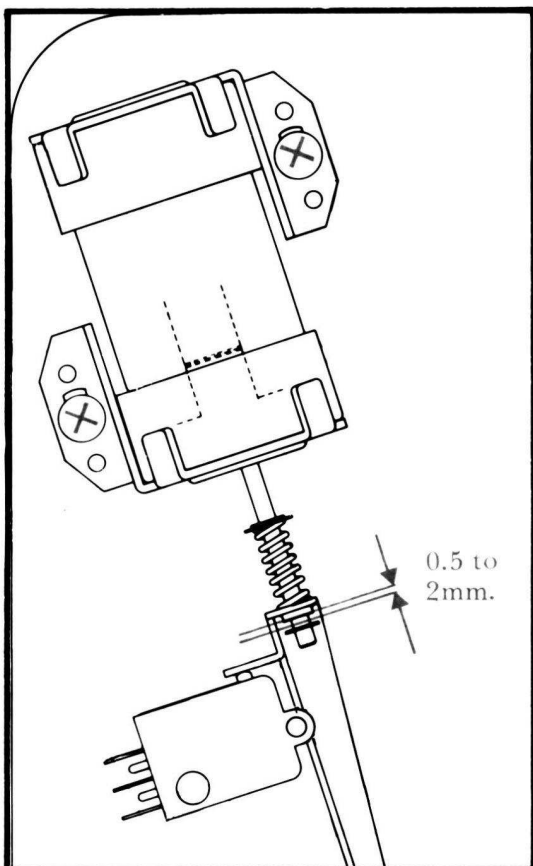

Fig. 3.3 The pinch roller solenoid

3.4 TURNTABLES

When replacing a reel motor, check with a pair of callipers the distances between the top of the turntable and the mounting plate before the turntable is removed. See Figure 3.4.

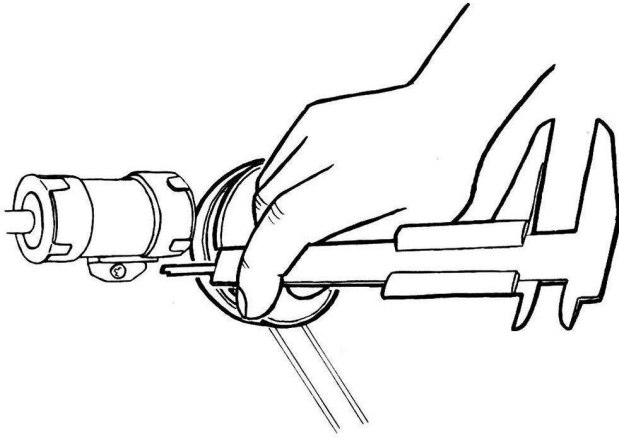

Fig. 3.4 *Checking the height of the turntable*

3.5 PINCH ROLLER

When replacing the pinch roller, make sure there is a washer on both sides when installing the new roller, see Figure 3.6.



Fig. 3.6 *Replacing the pinch roller*

The turntables are screwed onto the motor shaft with two screws. Use a long narrow screwdriver. See Figure 3.5.

NOTE! The screws on some decks are 2 mm Allen screws.

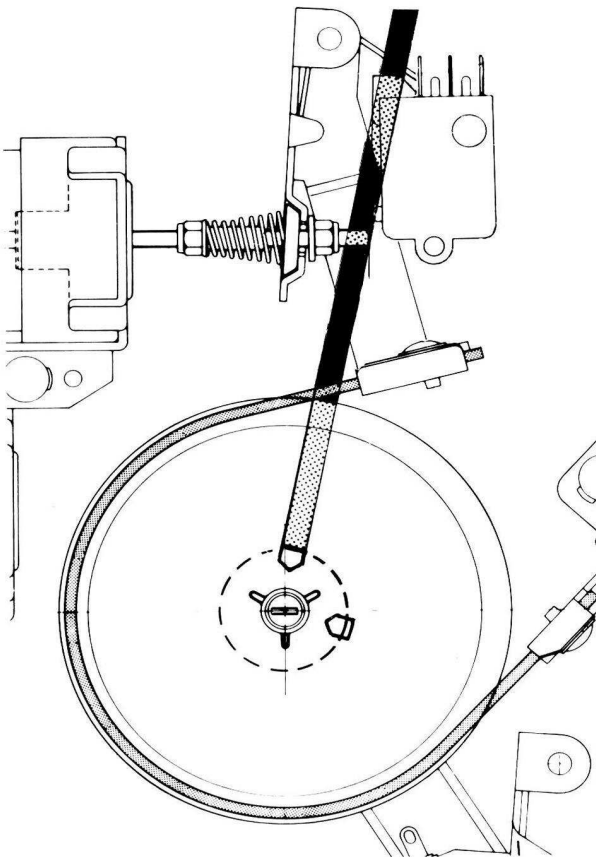

Fig. 3.5 *Removing the turntable*

4.0 TAPE PATH ADJUSTMENTS

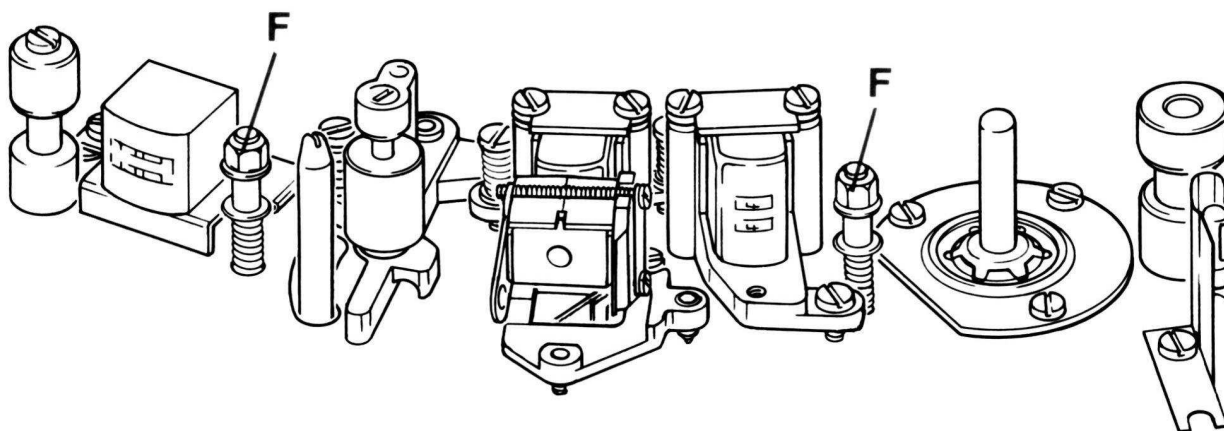

Fig. 4.1 Adjustable tape guides

4.1 TAPE PATH

After replacement of one single part in the tape path, it may often be necessary to adjust the replaced part only. If, however, more parts have to be adjusted, a complete check and adjustment of the entire tape path must be performed. The adjustments must be carried out in the same sequence as explained below in order to eliminate the effects of mutual interaction. The tape path must be thoroughly cleaned before adjustments are carried out. Use tape without any defects.

NOTE! If the heads have grooves caused by wear, adjustment of the heads should be avoided.

Seal all screws in the tape path after the adjustments.

4.2 VISUAL CHECK

Load the deck with a tape and move the pinch roller arm slowly (by hand) into the normal forward drive position. Check that the height position of the adjustable tape guides (Figure 4.1-F) is correct. It is permissible for the tape to touch the tape guides when the deck is in **PLAY** or as the pinch roller arm moves into place. However, the tape must by no means bulge at the flanges.

4.3 ALIGNING THE HUM SHIELD FOR THE PLAYBACK HEAD

The hum shield for the playback head is positioned on the pinch roller arm so that the shield is right in front of the head during playback. Set the deck to stereo playback with both **SOURCE/TAPE** buttons in the position **TAPE** without tape in the tape path. Put a piece of paper between the photoelectric end-stop sensor and the light. Set the deck to **PLAY**.

Connect an a.c. voltmeter to each of the **LINE** outputs. Hold the shield and loosen screw C (Figure 4.2) one quarter turn.

Pull the shield as far away from the head as the mounting hole permits. Adjust the shield sideways to obtain a minimum reading on both voltmeters, or the best possible compromise. When adjustment is completed, tighten the screw and seal with lacquer.

4.4 PINCH ROLLER ADJUSTMENTS

Prior to making electrical adjustments on the heads, it is essential to make the tape run without sideways movement through the tape path and that the pinch roller wheel is parallel to the capstan.

NOTE! After each attempt to adjust the pinch roller, stop the tape. Then restart and check the result.

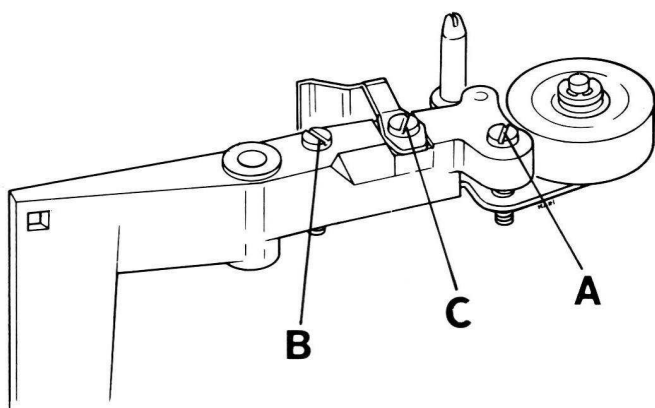

Fig. 4.2 The pinch roller adjustment

Zenith Adjustment

Move the pinch roller arm forward and check by visual inspection that the capstan and the pinch roller wheel are parallel. If not, adjust with screw A in Figure 4.2. Seal the screw with lacquer.

Azimuth Adjustment

This adjustment is performed when the deck is loaded with tape and the deck is in PLAY. Brake the supply reel lightly (by hand) and check that the tape does not move up or down on the capstan or in the tape guides. If necessary, adjust with screw B in Figure 4.2. Seal the screw with lacquer.

4.5 CHECKING AND RE-ADJUSTING THE FLUTTER ROLLER

After each attempt to adjust the flutter roller, stop the tape with the STOP button. Then re-start the tape with the PLAY button.

Parallelism adjustment

Use the head tool to check the parallelism and if necessary adjust screw A with the Allen Key, Figure 4.3

If the special tool for checking the parallelism is not available, insert a tape in the tape path. Set the deck to PLAY. Adjust screw A, Figure 4.3 until the tape does not bilge on either side of the roller.

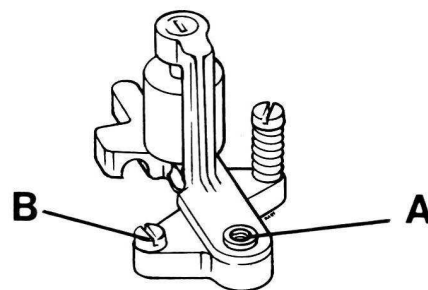

Fig. 4.3 The flutter roller adjustment (Seen from the rear)

Azimuth adjustment

Insert a tape and set the tape speed control to 7½ ips. Adjust screw B (Figure 4.3) with a screwdriver to obtain a very slight tilt of the roller (1° to 2°) towards the left. Set the deck to PLAY and adjust as follows:

Adjust the roller to the left by means of screw B Figure 4.3 until it can be clearly seen that the tape touches the upper flange on the tape guide nearest the roller. Then move the roller slightly towards the right, until the tape barely touches the upper flange of the same tape guide. When properly adjusted, the tape will move away from the lower flange and barely touch the upper flange.

To make checking easier, place an electric lamp above and behind the deck and look from the front against the lower flange on the tape guide.

5.0 ERASE AND BIAS CIRCUITS

5.1 OSCILLATOR FREQUENCY

The oscillator frequency is $85.5 \text{ kHz} \pm 2 \text{ kHz}$. If necessary the frequency can be adjusted by replacing R3 and R4 with different values. Use a frequency counter to measure the frequency.

NOTE! R3 and R4 are 1% resistors.

5.2 CHECKING THE ERASE VOLTAGE

Set the deck to stereo RECORD (both channels). Connect an a.c. voltmeter to the upper half of the erase head by means of a low capacitance probe. The voltage should be 80 to 130 V. Then check that the same voltage appears across the lower half of the head. Set the deck to mono RECORD on channel L and check the voltage across the upper half of the erase head. The deviation from the voltage measured for stereo should not exceed 10 V. Then proceed with channel R.

5.3 BIAS CURRENT

Set the deck to stereo RECORD and measure the voltage across the upper half of the bias head by means of an a.c. voltmeter. Adjust the voltage to 22 V by means of R44. Check the voltage across the lower half of the head and adjust with R144 to 22 V.

5.4 HEADS

Of all the head adjustments, the parallelism adjustment has any effect on the tape guidance system. Check, and if necessary, adjust the parallelism for the playback head, the record head and the erase head. The parallelism alignment is referred to the capstan. A special tool is available.

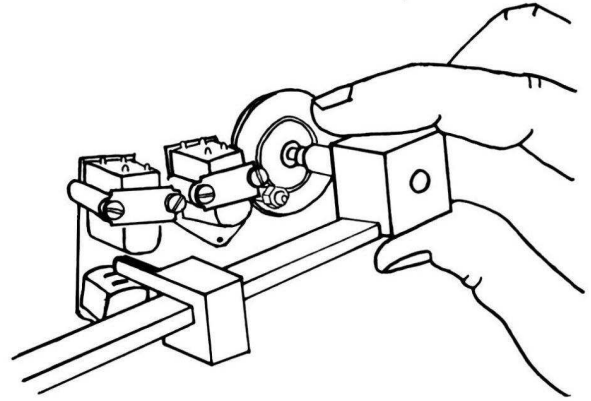

Fig. 5.1 Adjusting the parallelism with the head tool.

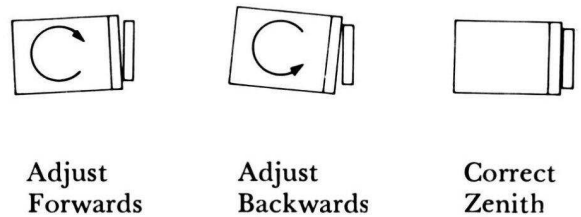
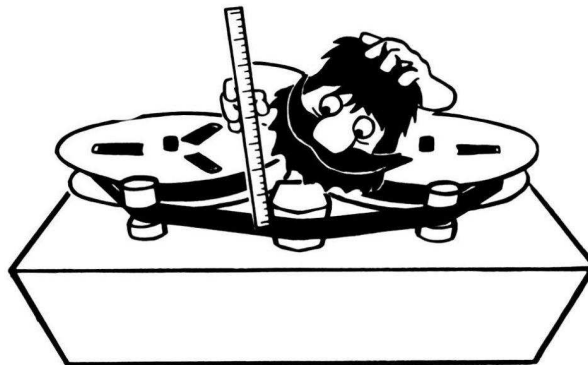

Fig. 5.2 Checking the head parallelism with the head tool



6.0 HEAD ALIGNMENT WITH TANDBERG TEST TAPES – FOUR TRACKS

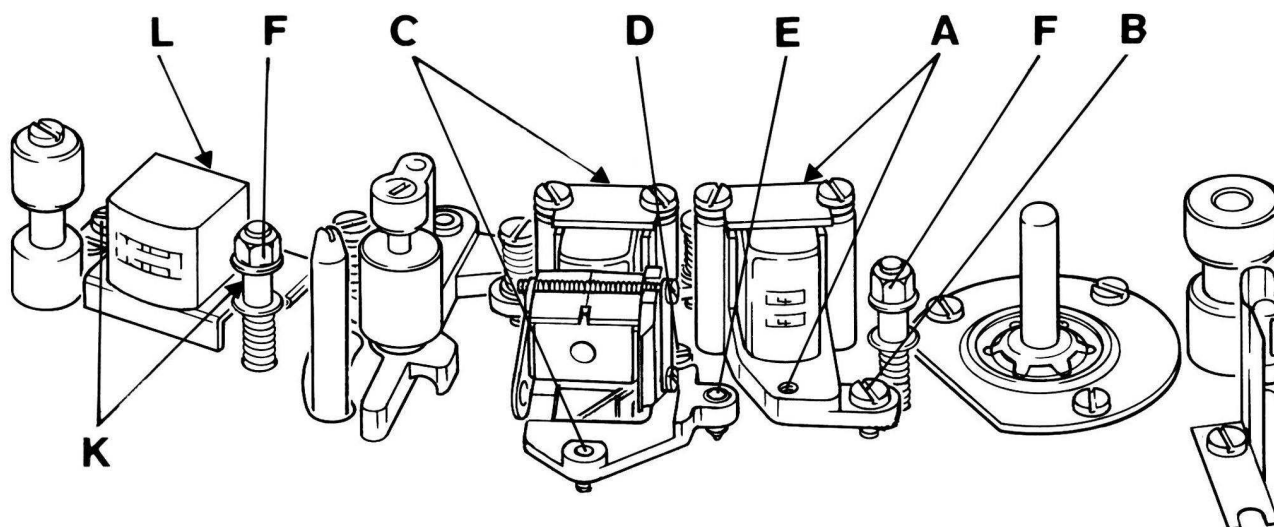

Fig. 6.1 The head adjustment screws

6.1 PLAYBACK HEAD

Connect an a.c. voltmeter to each of the LINE OUT sockets and set the SOURCE/TAPE buttons to TAPE.

Height Adjustments

Play back Tandberg test tape No. 1. This is a full track prerecorded tape with 1000 Hz recorded at 7½ ips and with the area corresponding to track 3 reduced by approximately 35 dB. Adjust the height of the playback head by means of the screws A, Figure 6.1, until minimum output is obtained from track 3, channel R, while endeavouring to maintain the head-front parallel to the tape.

Azimuth Adjustments

Play back Tandberg test tape No. 2 at 7½ ips. (or a standard azimuth tape). Adjust the azimuth position of the playback head by means of screw B, Figure 6.1, until maximum output on the voltmeters is obtained on both channels; alternatively, adjust for the best compromise.

NOTE! Seal all screws in the tape path after the adjustments.

6.2 RECORD HEAD

Height Adjustment by Visual Inspection

Insert a new tape and set the deck to PLAY. Check visually that the tape appears to run parallel with the upper track on the record head, within approximately 0.1 mm (0.004") see Figure 6.2. If necessary adjust the height with screws C, Figure 6.1, while endeavouring to maintain the head-front parallel to the tape.

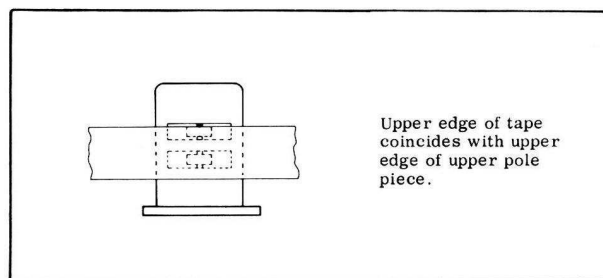

Fig. 6.2 Four-track record head.

Height Adjustment by track Measurement

Record in stereo a 1,000 Hz signal well above the normal level, first in one direction, then in the opposite direction. Cut off a length of tape and dip it into a solution of fine-grained iron-oxide powder and alcohol (Magna See). The tracks will then be visible as four dark stripes.

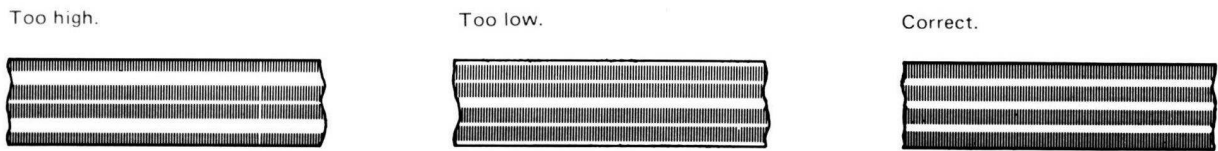

Fig. 6.3 Track measurement, four-track record head

Figure 6.3 shows the correct pattern on the tape and the patterns obtained when the head is either too high or too low. Repeat the adjustment until the patterns are correct.

Azimuth Adjustment

Load the deck with a new tape and record at $3\frac{1}{4}$ $3\frac{3}{4}$ ips a 12 to 13 kHz signal in stereo. Set the SOURCE/TAPE buttons to TAPE. Adjust both OUTPUT LEVEL potentiometers for approximately 150 mV reading on a.c. voltmeters connected to the LINE OUT socket. Adjust the record head azimuth screw D, Figure 6.1, for maximum output from both channels or the best compromise.



6.3 BIAS HEAD

Horizontal Adjustment

Before adjusting the bias head, turn the screw E, Figure 6.1, clockwise until the bias head stops moving to the left.

Connect an a.c. voltmeter across one half of the record head and set the deck to stereo record. Insert a 2 mm Allen key into the Allen screw E, Figure 6.1. Turn the screw counter clockwise, and the bias heads will move to the right. Induced voltage (bias) in the record head increases to a maximum. Then turn the Allen key clockwise (the bias head moves to the left) until the induced voltage in the record head is reduced by 10 to 15% below maximum.

6.4 ERASE HEAD

Height Adjustment

By visual inspection check that approximately 0.25 mm (0.01") of the upper half of the erase head is visible above the tape, see Figure 6.4.

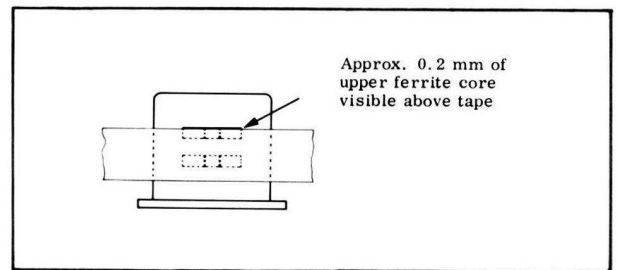

Fig. 6.4 Four-track erase head.

Insert Tandberg test tape No. 9 and record on channel R (track 3) a 400 Hz signal at $7\frac{1}{2}$ ips well above normal recording level. Dip the tape in a solution of fine grained iron oxide powder and alcohol (Magna See). Check that the recorded track is positioned in the centre of the erased track, see Figure 6.1. If necessary, adjust the height of the erase head by means of screws K and L, see Figure 2.7, and repeat the above check.

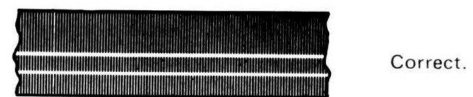

Fig. 6.5 Track measurement, four-track erase head

Azimuth Adjustment

Check that the head-front of the erase head is perpendicular to the mounting plate. If necessary, adjust the azimuth position by means of the screws K, see Figure 6.1. This adjustment is not critical.

7.0 HEAD ALIGNMENT WITHOUT TEST TAPES – 4 TRACKS

7.1 PLAYBACK HEAD

Height Adjustment

The height of the playback head is adjusted by the screws A, see Figure 6.1. The upper edge of the tape shall run flush with the upper part of the head lamination for channel L.

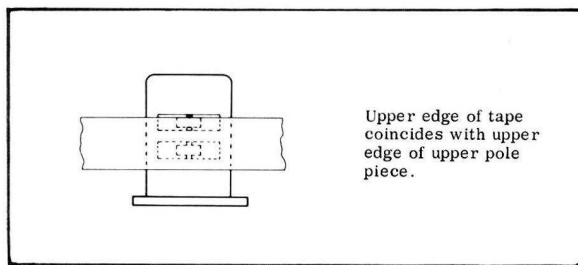

Fig. 6.5 Four-track playback head

Azimuth Adjustment

Set the SOURCE/TAPE buttons to TAPE. Play back a standard azimuth alignment tape with an a.c. voltmeter connected to each LINE OUT socket. Adjust the position of the playback head by the azimuth adjustment screw B, see Figure 6.1, until a maximum reading is obtained on the voltmeters.

7.2 RECORD HEAD

Follow the instructions given under paragraph 6.2.

7.3 BIAS HEAD

Follow the instructions given under paragraph 6.3.

7.4 ERASE HEAD

Height Adjustments

The height of the erase head is aligned by the height adjustment screws K and L, see Figure 6.1.

Approximately 0.25 mm (0.01") of the ferrite core for the upper track of the erase head should be visible above the tape, see Figure 6.4.

8.0 HEAD ALIGNMENT— 2 TRACKS

8.1 PLAYBACK HEAD

Height Adjustment

The height of the playback head is aligned by the screws A, Figure 6.1. The tape shall run parallel with the upper and lower edges of the laminations. See Figure 6.6. If necessary, re-adjust and check the azimuth position.

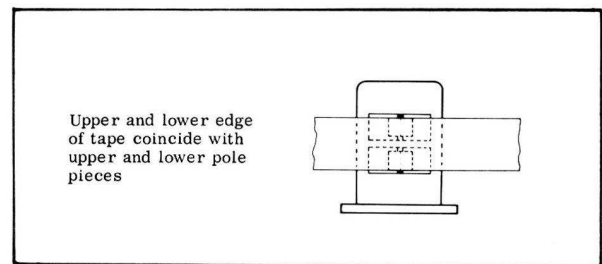

Fig. 6.6 Two-track playback head

8.2 RECORD HEAD

Height Adjustment

The height of the record head is aligned by the screws C, Figure 6.1. Record in stereo a 1,000 Hz signal well above normal recording level. Dip the tape in Magna See and check that the tracks are distributed symmetrically across the tape. See Figure 6.7. If necessary, re-adjust and check the azimuth position.

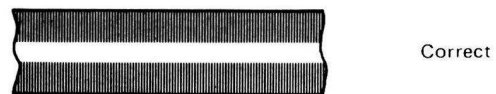

Fig. 6.7 Two track record head

8.3 ERASE HEAD

Height Adjustment

The height of the erase head is aligned by the screws K and L, Figure 6.1. Adjust until equal parts of the head laminations are visible above and below the tape.

9.0 EXCHANGING HEADS AND MODIFICATION FROM FOUR TRACKS TO TWO TRACKS

The following parts have to be changed when modifying a four-track version to a two-track version and when new heads are fitted.

The value of the total capacitance is labelled on the heads.

PART	FOUR TRACKS	TWO TRACKS
Playback head	2215 - 10P	2016 - 11P
Record head	5198 - 11R	5199 - 07R
Bias head	2276 - 05B	2013 - 06B
Erase head	2160 - 18E	2014 - 20E
C12 - C112	3300 pF*	3300 pF*
C13 - C113	250 pF*	250 pF*

* Capacitor must be connected in parallel until value of total capacitance is achieved.

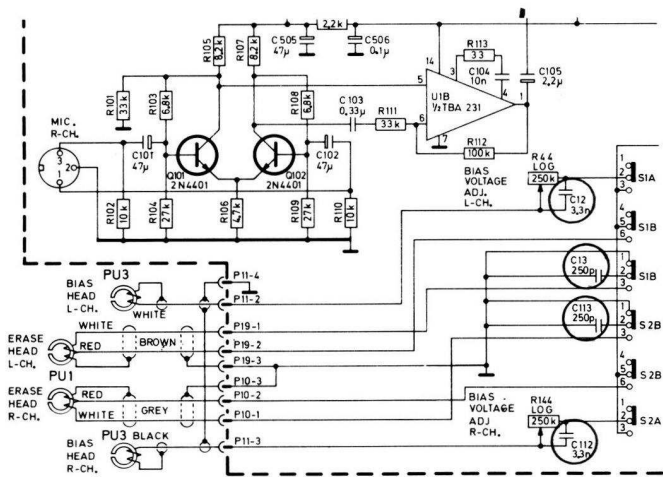

When a 9100X or a 9200XD has to be converted to two-tracks, use the record head for the model 3300X or 3400X. Do not use the two tracks record head for model 9000X.

10.0 CHANGING FROM 220 V/50 HZ TO 115 V/60 HZ

The following four operations are necessary:

1. Change the 50 Hz motor pulley for a 60 Hz motor pulley or vice versa.
2. Reduce or increase the capacitor for the wind and rewind motors as indicated in Table 1.

Rewind or wind motor	Capacitor	
	50 Hz	60 Hz
HT 149	2.3 + 0.9 μ F	2.3 μ F
RO14.65-4	2.8 + 0.7 μ F	2.8 μ F
IB942R1	4 μ F	4 μ F

Table 1

3. Reduce or increase the capacitor for the capstan motor as indicated in Table 2.

Capstan motor	50 Hz	60 Hz
HSZ 32.50	1.5 μ F	1.2 μ F

Table 2

4. One of the black wires from the power switch is connected to the 110 V terminal or 230 V terminal on the transformer. Move this wire from the present terminal to the other terminal (230 V or 110 V).

11.0 CHANGING THE PHOTO-ELECTRIC END-STOP

If the photo-electric end-stop lamp is changed the following adjustments will be necessary.

With no tape in the machine, measure the d.c. voltage on the blue wire of the photo-transistor Q1. The blue wire goes to pin 2 on the P2 row of contacts on the logic board.

Make sure that the filament wires are in their correct position behind the hole in the shield. Check this by moving the lamp up and down in the shield to obtain a minimum reading on the d.c. voltmeter.

When a tape is loaded onto the machine the voltage shall rise to a minimum of 8 V. The threshold level for the end-stop is about 6.5 V measured on the blue wire.

If triple-play tape is used it may be difficult to achieve a reading of 8 V. The brightness of the lamp can be reduced by increasing the value of R1 to a maximum of 180 ohms.

NOTE! If the machine stops when a piece of leader tape is passing the end-stop this happens simply because the leader tape is thin and allows sufficient light through to operate the end-stop. Normally the whole tape (including the leader tape) must pass before the machine stops. A piece of transparent leader tape will stop the machine if it is long enough, before the tape runs off the reel.

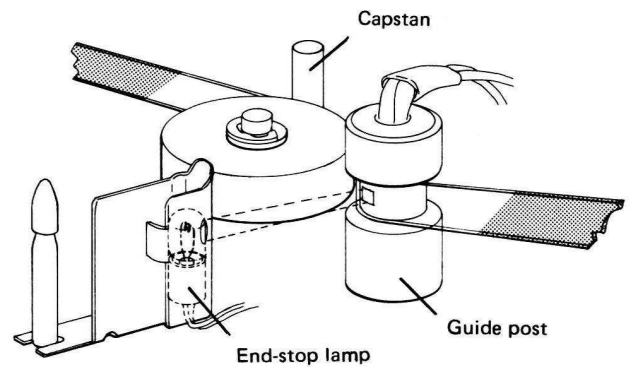
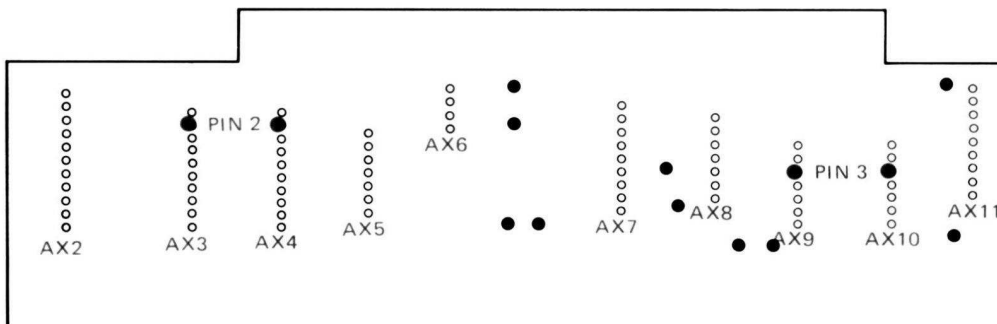

Fig. 11.1 The photo-electric end-stop

ADJUSTMENT TABLE MODEL 9100X AND 9200XD.

No.	Adjustment or check	Test tape No.	Set the deck to	Measuring instrument	Measure at:	Correct reading	Dolby* switch	Adjust	Speed	Comments
1.1	Playback head azimuth	2	Playback	a.c. voltmeters	LINE OUT	Maximum output	OFF	Azimuth	7½	
1.2	Playback curve NAB or DIN 19 H	3	Playback	a.c. voltmeters	LINE OUT	+ 4 dB - 2.5 dB	OFF	See Fig. 4-1B	7½	Playback curve, NAB. The tape contains the following frequencies: 250 Hz (Reference) - 10 kHz - 5 kHz - 1000 Hz - 100 Hz - 50 Hz - 250 Hz (Ref.). Playback curve DIN 19 H. The tape contains the following frequencies: 1000 Hz (Reference) - 18 kHz - 15 kHz - 10 kHz - 4 kHz - 125 Hz - 40 Hz - 1000 Hz (Ref.).
1.3	Playback level 9100X	3	Playback	a.c. voltmeters	LINE OUT	1.2 V	-	PLAYBACK LEVEL R31 - R131	7½	
1.4	Playback meter adjustments, 9100X	-	See comments	a.c. voltmeters	LINE OUT	1.5 V	-	PLAYBACK METER R30 - R130	7½	To be performed without tape. Put a piece of paper between the light source and the photo-transistor. Set the deck in SOURCE. Depress the PLAY button. Connect a audio-generator, 1000 Hz to LINE IN. Adjust with the LINE INPUT LEVEL to 1.5 V on the voltmeters. Adjust R30 (L) and R130 (R) to 0 dB indication on the meters.
1.5	DOLBY playback level 9200XD	25	Playback	a.c. voltmeter	See comments	580 mV	OFF	PLAYBACK LEVEL, R31 - R131	7½	Measure on pin 3, contact AX9 (L) and contact AX10 (R) on the main board. Check that the output (LINE OUT) are within ± 0.5 dB.
1.6	Speed check 9100X and 9200XD	11	Playback	Frequency counter	LINE OUT	1000 Hz ± 7% 993-1007 Hz	OFF		7½	
1.7	Bias, pre-adjustments 9100X and 9200XD	-	Record	a.c. voltmeter	Measure across the bias head or see comments	Approx. 22 V	OFF	BIAS ADJ. R44 - R144	7½	Measure on pin 2 (L) and pin 3 (R) on contact P11 on the main board.

Table 1.



Location of test points for Dolby levels on the main board, solder side

Adjustment of R11 on the Dolby decoder boards XA9 and XA10.

(Seen from the rear).

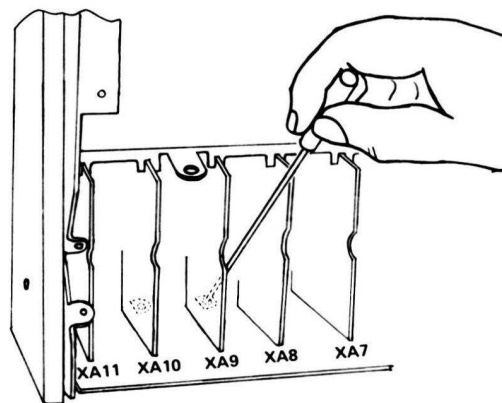

* The word "Dolby" is a Trade Mark of Dolby Laboratories Inc.

ADJUSTMENT TABLE, MODEL 9100X AND 9200XD

No.	Adjustment or check	Tape	Measuring instrument	Measure at:	DOLBY switch	SOURCE/TAPE buttons
2.1	Bias head horizontal adjustment	L.H. tape	a.c. voltmeters	LINE OUT	OFF	TAPE
2.2	Azimuth, record head	L.H. tape	a.c. voltmeters	LINE OUT	OFF	TAPE
2.3	Record/playback curves, models 9100X and 9200XD	L.H. tape	a.c. voltmeters	LINE OUT	OFF	TAPE
2.4	Record/playback curves, model 9200XD	L.H. tape	a.c. voltmeters	LINE OUT	OFF/NORM	TAPE
2.5	SOURCE/TAPE adjustment, model 9100X	L.H. tape	a.c. voltmeters	LINE OUT	-	SOURCE and TAPE
2.6	RECORD METER adjustment, model 9100X	L.H. tape	a.c. voltmeters	LINE OUT	-	TAPE
2.7	SOURCE/TAPE adjustment and PLAYBACK METER adjustment Model 9200XD	L.H. tape	a.c. voltmeter	See procedure	OFF	SOURCE and TAPE
2.8	Distortion	L.H. tape	Distortion meter	LINE OUT	OFF	TAPE
2.9	Wow and flutter	L.H. tape	Wow and flutter meter	LINE OUT	OFF	TAPE

Table 2.

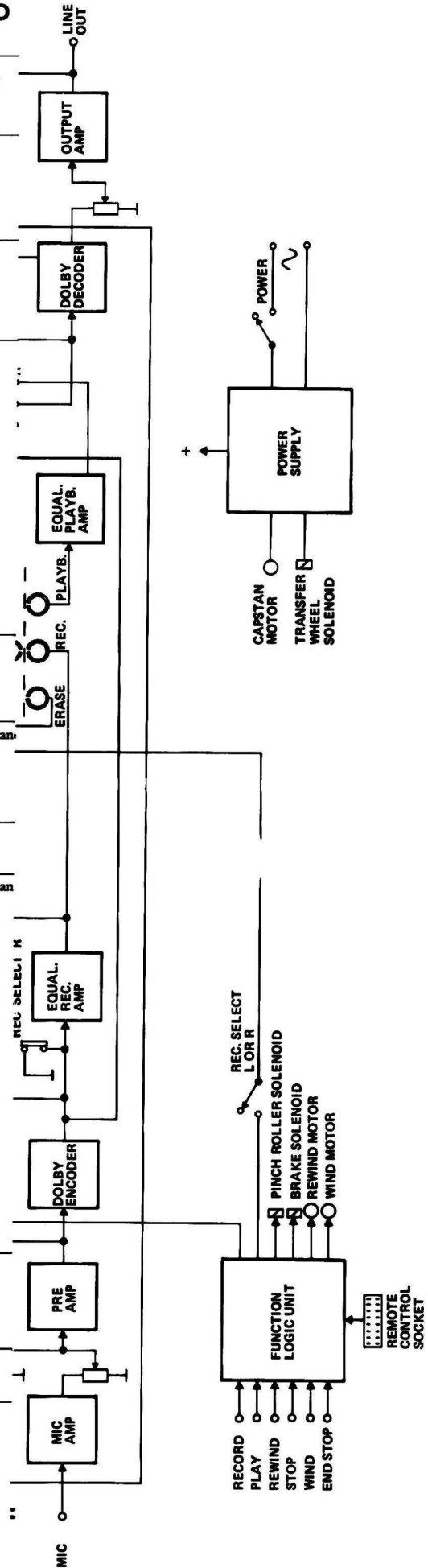

Block diagram — 9200XD

ADJUSTMENT TABLE, MODEL 9100X AND 9200XD

No.	Adjustment or check	Tape	Measuring instrument	Measure at:	DOLBY switch	SOURCE/TAPE buttons	Set the deck to	Procedure:
2.1	Bias head horizontal adjustment	L.H. tape	a.c. voltmeters	LINE OUT	OFF	TAPE	RECORD 7½ ips	Connect an audio-generator to LINE IN. Set the generator to 1000 Hz and adjust with the LINE INPUT LEVEL to approx. 0.5 V on the voltmeters. Turn the screw E, Fig. 6.1 (2 mm Allen screw) clockwise, and the head moves to the left. Then turn the screw counter clockwise to maximum reading on the voltmeters.
2.2	Azimuth, record head	L.H. tape	a.c. voltmeters	LINE OUT	OFF	TAPE	RECORD 3¾ ips	Connect an audio-generator to LINE IN. Start stereo recording in 3¾ ips of a 400 Hz signal 30 dB below normal recording level (0 dB). Use the voltmeter readings as reference level. Then record a 16,000 Hz signal and turn the screw D, Fig. 6.1 to maximum reading on the voltmeters.
2.3	Record/playback curves, models 9100X and 9200XD	L.H. tape	a.c. voltmeters	LINE OUT	OFF	TAPE	RECORD 3¾ ips	Connect an audio-generator to LINE IN. Start stereo recording in 3¾ ips of a 400 Hz signal 30 dB below normal recording level (0 dB). Use the voltmeter readings as reference level. Then record a 16,000 Hz signal at the same level and check the output voltage is within ± 2 dB. If the voltage is too high, increase bias current by means of R44 (L) and R144 (R). If the voltage is too low, alter the input signal frequency to 1000 Hz and adjust for maximum output voltage by means of R44 (L) and R144 (R). Then go back to 400 Hz, establish the reference level, and re-check the output level at 16,000 Hz. When the tolerance at 16,000 Hz has been met, check that the output level not deviate more than ± 2 dB from the following frequencies: 7½ ips. ± 2 dB 30-22,000 Hz 3¾ ips. ± 2 dB 40-18,000 Hz 1 7/8 ips. ± 2 dB 40 - 9000 Hz
2.4	Record/playback curves, model 9200XD	L.H. tape	a.c. voltmeters	LINE OUT	OFF/ NORM	TAPE	RECORD 3¾ ips	When you switch the Dolby knob from OFF to NORM, check that the output level not deviate more than ± 3 dB at the following frequencies: 1000, 5000, 10,000, 15,000, 18,000 Hz. Use the same recording level as in adjustment No. 2.3.
2.5	SOURCE/TAPE adjustment, model 9100X	L.H. tape	a.c. voltmeters	LINE OUT	—	SOURCE and TAPE	RECORD 3¾ ips	Connect an audio-generator to LINE IN. Set the generator to 400 Hz and adjust in SOURCE with the LINE INPUT LEVER to 1.5 V on the voltmeters. Set the deck to stereo recording and push the TAPE/SOURCE buttons down to TAPE. Adjust to 1.7 V with R19 (L) and R119 (R).
2.6	RECORD METER adjustment, model 9100X	L.H. tape	a.c. voltmeters	LINE OUT	—	TAPE	RECORD 7½ ips	Set the levels to 1.7 V in TAPE according to paragraph 2.5. Adjust R25 (L) and R125 (R) for 0 dB indication on the meters.
2.7	SOURCE/TAPE adjustment and PLAYBACK METER adjustment Model 9200XD	L.H. tape	a.c. voltmeter	See procedure	OFF	SOURCE and TAPE	RECORD and PLAY 3¾ ips	Load the deck with a high quality tape, for example Maxell UD35. Connect an audio-generator, 1000 Hz to LINE IN. Set the deck to stereo record in SOURCE. Adjust with the LINE INPUT LEVEL to 580 mV on pin 2 on Dolby decoder AX3 and AX4. Then check for 580 mV ± 0.5 dB at pin 3 on Dolby encoder AX9 and AX10. Re-adjust R11, on Dolby decoder AX9 and AX10 if necessary. Increase LINE INPUT LEVEL to 1.15 V at pin 3 on Dolby decoder AX9 - AX10. Read the output voltage on the LINE OUT and remember the reading. (OUTPUT LEVEL always to max.) Set the deck to SOURCE. Adjust RECORD LEVEL R19 (L) and R119 (R) so that the level reading is 1 dB higher than the previous reading on LINE OUT. (Only when using Maxell UD35 tape, if not, adjust to the same reading on the LINE OUT.) Adjust the R25 (L) and R125 (R) to 0 dB indication on the meters. Set the deck to SOURCE. Adjust LINE INPUT LEVEL to the same level as previously read on LINE OUT. Set the deck to PLAY and adjust the R30 (L) and R130 (R) to 0 dB indication on the meters.
2.8	Distortion	L.H. tape	Distortion meter	LINE OUT	OFF	TAPE	RECORD 7½ ips	Connect audio generator (or distortion meter generator) 1000 Hz, to LINE IN. Record to 0 dB indication on the meters, and read the distortion on the LINE OUT. Model 9100X - max. 3% Model 9200XD - max. 2%
2.9	Wow and flutter	L.H. tape	Wow and flutter meter	LINE OUT	OFF	TAPE	RECORD All speeds	Connect the wow-and-flutter-meter generator to the LINE IN. Read on the LINE OUT and inn all speeds.

Table 2.

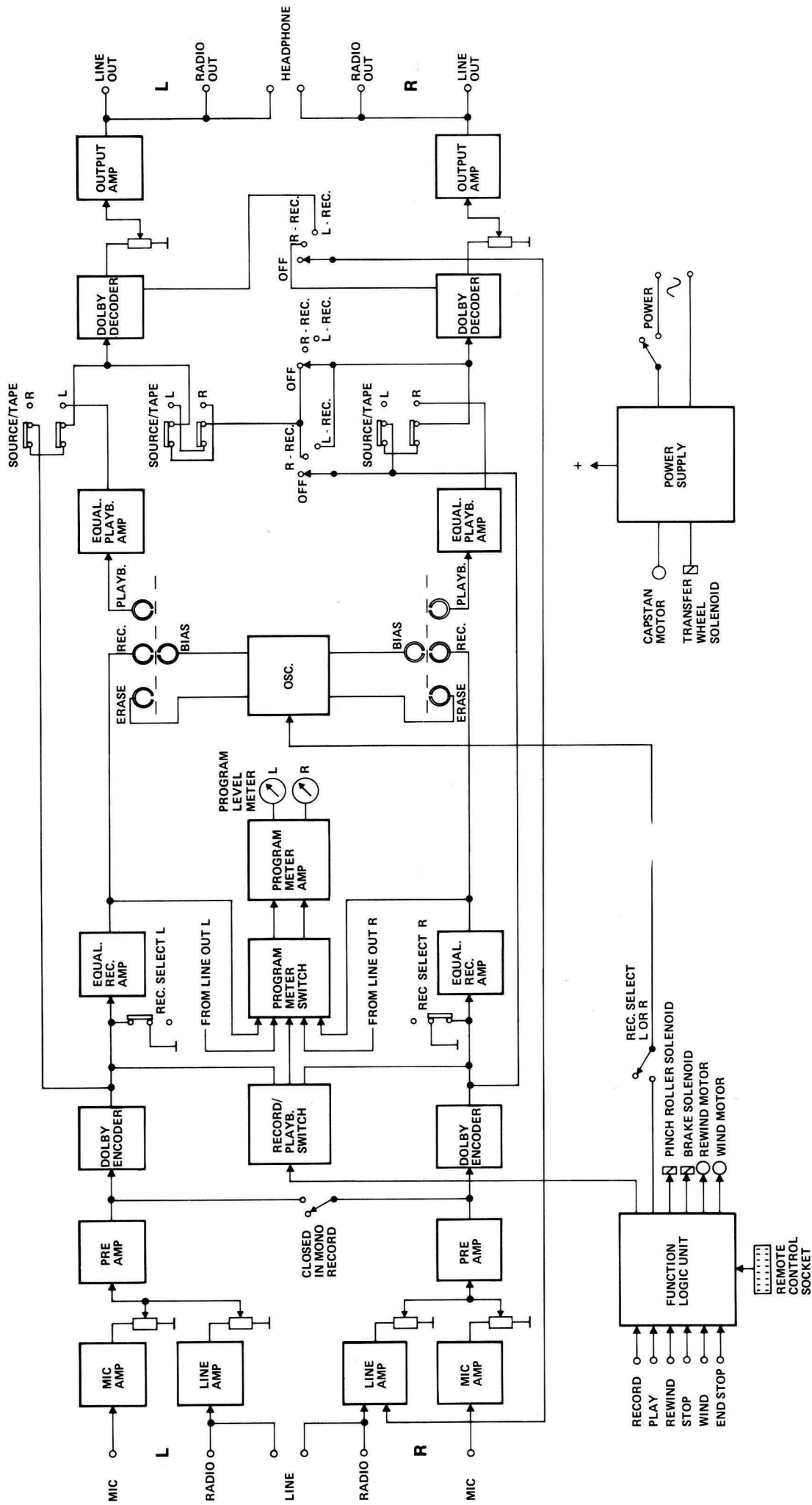

Block diagram — 9200XD

A1 MAIN BOARD (NOTES 1-5)

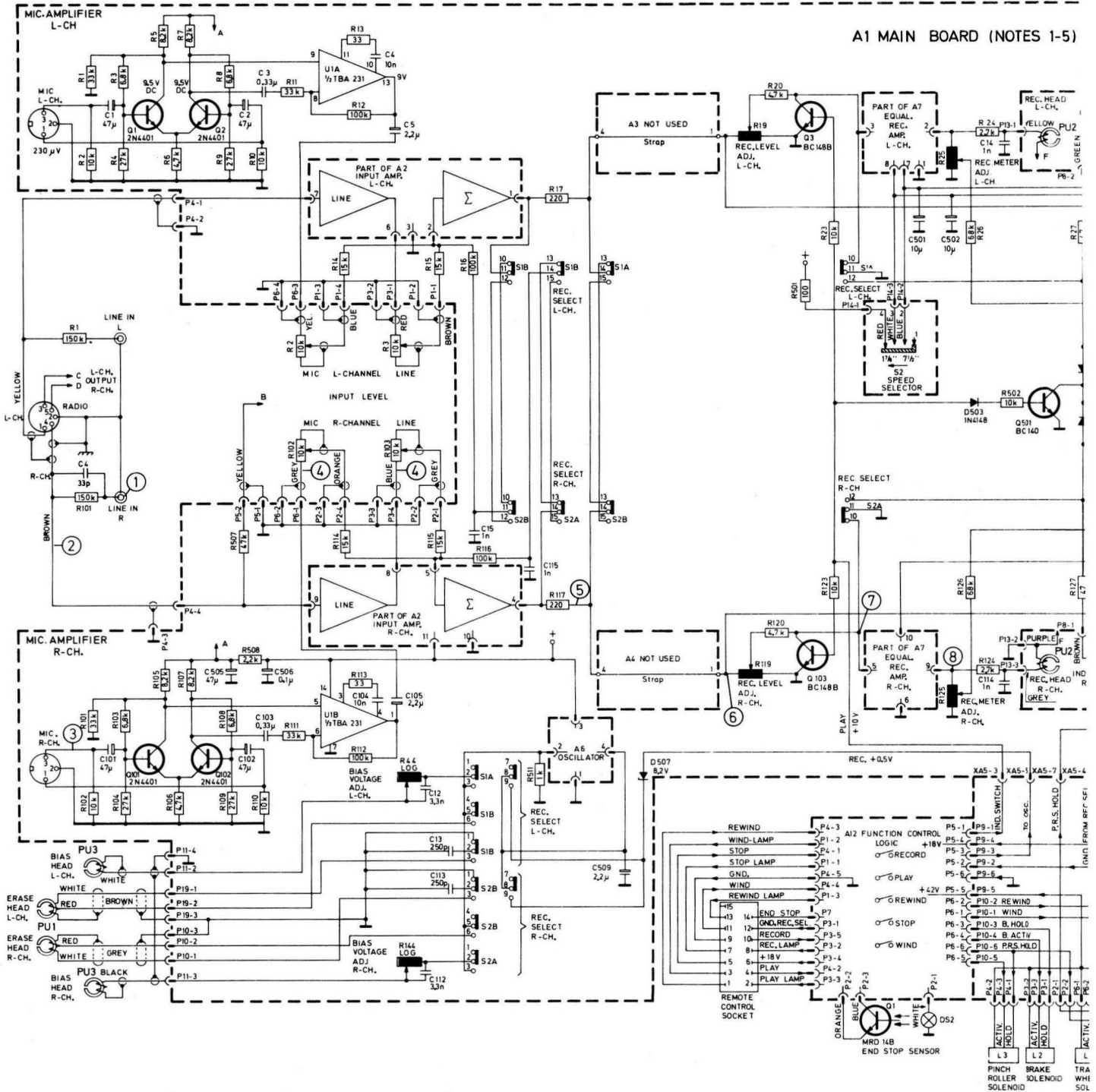

ALL THE SWITCHES ARE SEEN FROM SOLDER SIDE (NOTE 2 AND 3)

REFERENCE DESIGNATIONS	
NO PREFIX	PREFIX WITH A1
A1 - A12	C1-15, 101-105, 501-508
B1 - 3	D1-3, 101-103, 501-507
D51 - 6	D1-2, 101-106, 501
L1 - 2	R1-2, 101-144, 501-511
M1 - 2	S1-4
PU1-4	Q1, Q104
U1	R21, R21
U1-104	

COMPONENTS CHANGED				
REF DESIGN	FROM	TO	DATE	E.C.O. NO
R1, 101	150k	68k		
C1		12μF		

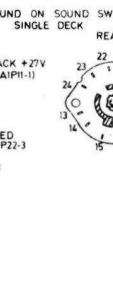
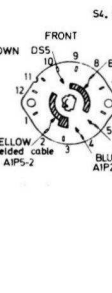
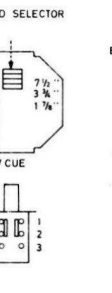
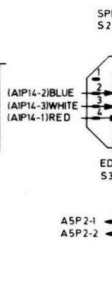
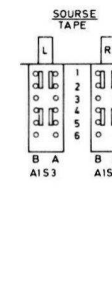
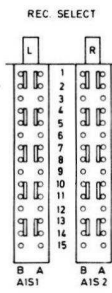

A1 MAIN BOARD (NOTES 1-5)

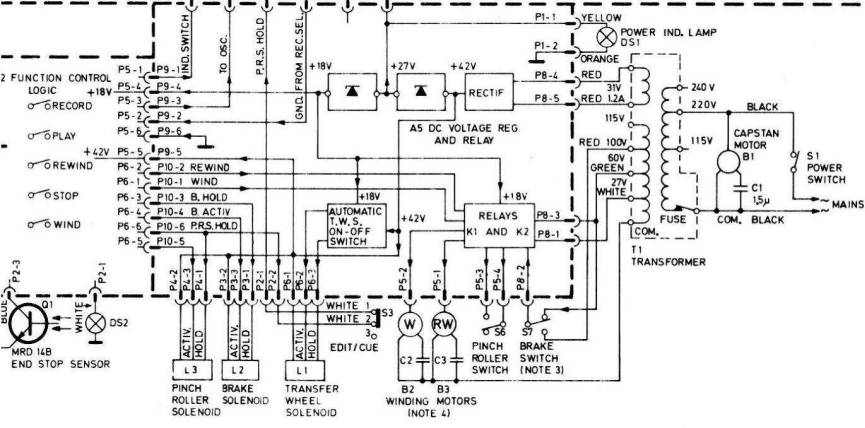
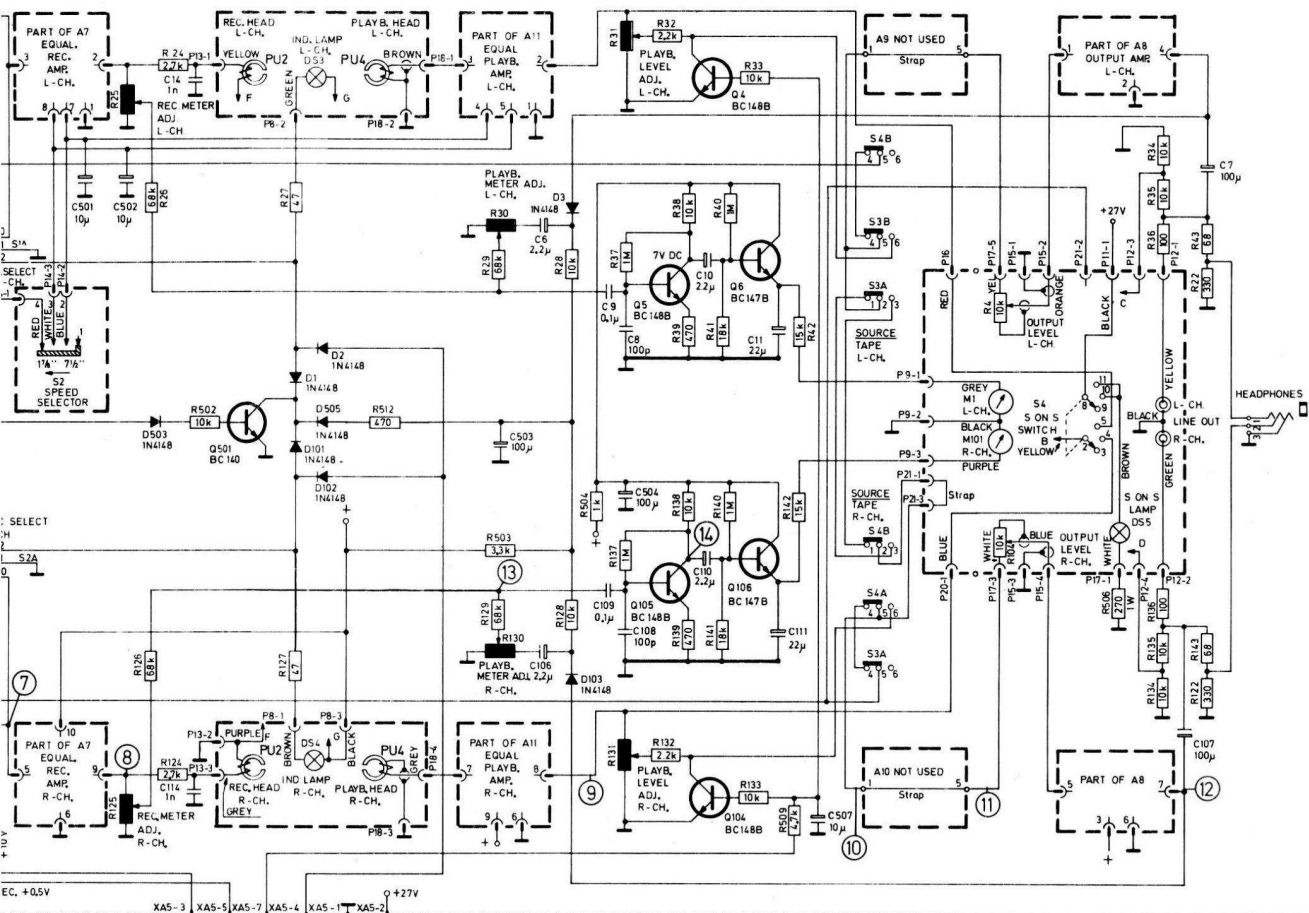

NOTES:

1. UNLESS OTHERWISE SPECIFIED, RESISTANCE IN OHMS
2. WHEN REFERRING TO A COMPONENT ON A PRINTED BOARD ASSEMBLY PUT THE ASSY DESIGNATION IN FRONT OF THE COMPONENT REFERENCE DESIGNATION (E.G. SPECIFY A1 R1 AND NOT ONLY R1)
3. ALL SWITCH AND RELAY CONTACTS ARE SHOWN IN THE "POWER OFF" POSITION.
4. THE MOTOR CAPACITOR VALUE CHANGES WITH THE TYPE OF MOTORS USED AND WITH THE FREQUENCY. SEE TABLE 2
5. LEFT CHANNEL COMPONENTS HAVE 1-99 RIGHT CHANNEL COMPONENTS HAVE 100-199 AND COMPONENTS COMMON FOR BOTH CHANNELS HAVE 500 NUMBERS.

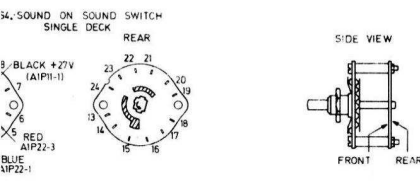

TABLE 1. SENSITIVITY OF AMPLIFIERS

L	R	SENSITIVITY AT 1000Hz AND 3 1/2 INCH SPEED
1		30mV 100mV (U.S.)
2		8mV 30mV (U.S.)
3		230 μV
4		30 mV
5		100 mV
6		80 mV
7		45 mV
8		1.3 V
9		190 mV
10		80 mV
11		85 mV
12		15 V
13		160 mV
14		2 V

TABLE 2. CAPASITOR AND VOLTAGE REQUIRMENTS FOR DIFFERENT WINDING MOTORS

M/RW MOTOR	C2/C3	
	50 Hz	60Hz
RO 1465	2.8±0.7 μF	2.2 μF
HT 149	2.3±0.9 μF	2.3 μF
1B 942 R	4 μF	4 μF

A1 MAIN BOARD CIRCUIT DIAGRAM MODEL 9100X

A12 FUNCTION CONTROL LOGIC

DC VOLTAGE REGULATOR

DOLBY ENCODER R. AND RELAY A5

OSCILLATOR A6

REC. - SELECT

MIC. L

MIC. R.

LINE OUT

HEADPHONES

SOURCE TAPE

DOLBY DECODER A9

DOLBY DECODER A10

OUTPUT AMP. A8

EQUAL. PLAYB. AMF A11

INPUT AMP A2

LIBY ENCODER L. A3

DOLBY ENCODER R. AND RELAY A4

DC VOLTAGE REGULATOR

A12 FUNCTION CONTROL LOGIC

MIC. REC. AMP. A7

OUTPUT AMP. A8

DOLBY DECODER A9

DOLBY DECODER A10

EQUAL. PLAYB. AMF A11

A1 MAIN BOARD - MODEL 9200 XD

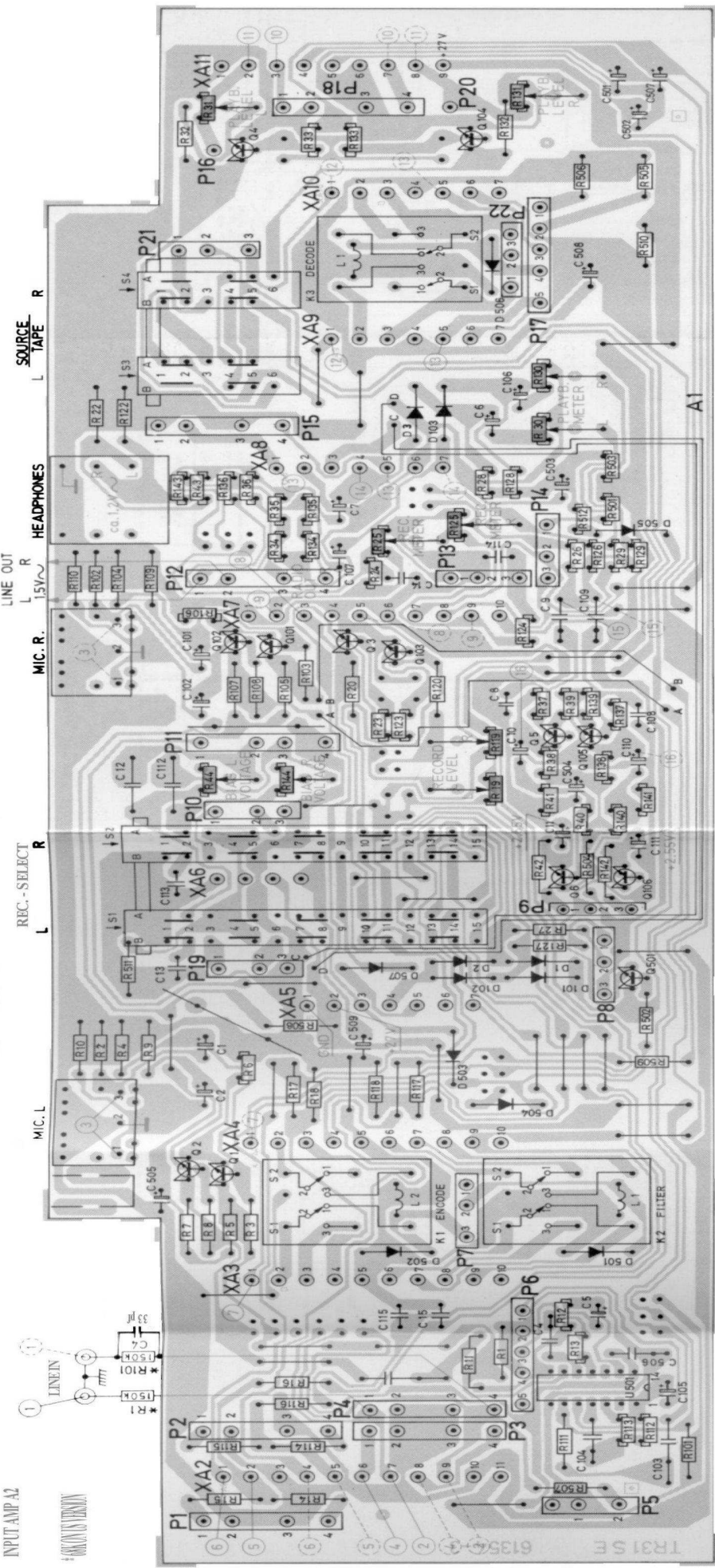

A1 MAIN BOARD - MODEL 9200 XD

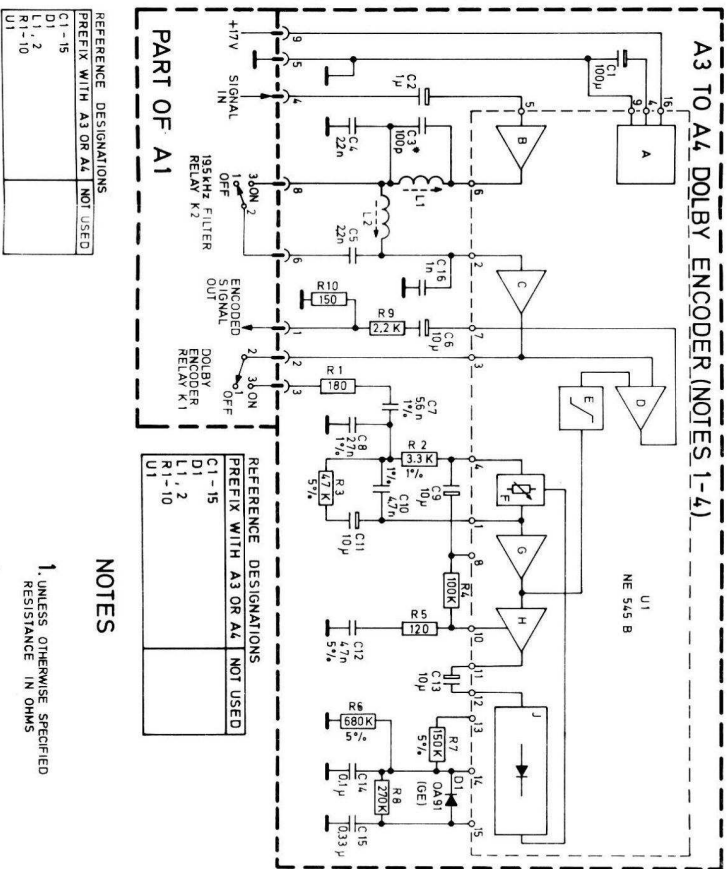
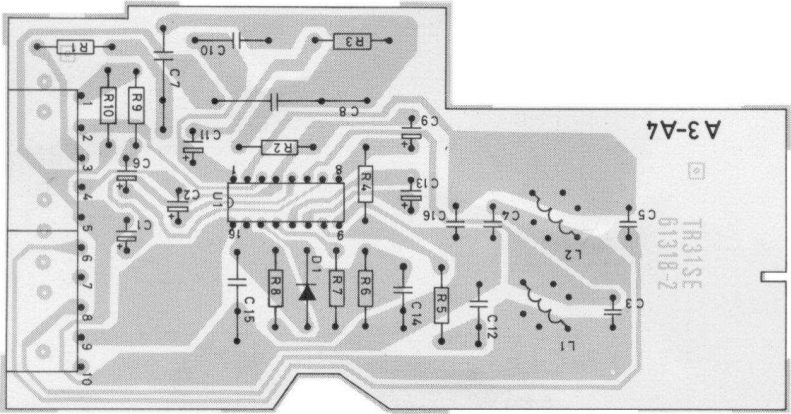

REFERENCE DESIGNATIONS
PREFIX WITH A3 OR A4 | NOT USED

C1-15	
D1	
L1-2	
R1-10	
U1	

REFERENCE DESIGNATIONS
PREFIX WITH A3 OR A4 | NOT USED

C1-15	
D1	
L1-2	
R1-10	
U1	

NOTES

1. UNLESS OTHERWISE SPECIFIED RESISTANCE IN OHMS
2. WHEN REFERRING TO A COMPONENT ON A PRINTED BOARD ASSEMBLY PUT THE ASSY DESIGNATION IN FRONT OF THE COMPONENT REFERENCE DESIGNATION (EG SPECIFY A3R1 AND NOT ONLY R1)
3. ALL SWITCH AND RELAY CONTACTS ARE SHOWN IN THE "POWER OFF" POSITION
4. A3 IS USED FOR THE L-CHANNEL, WHILE A4 IS USED FOR THE R CHANNEL. A3 IS INTERCHANGEABLE WITH A4

A3-A4 DOLBY ENCODER

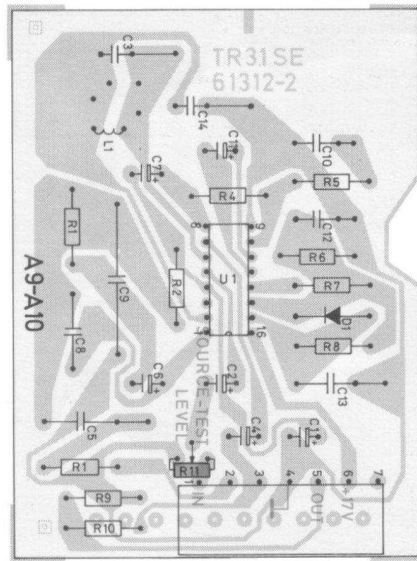

A9-A10 DOLBY DECODER

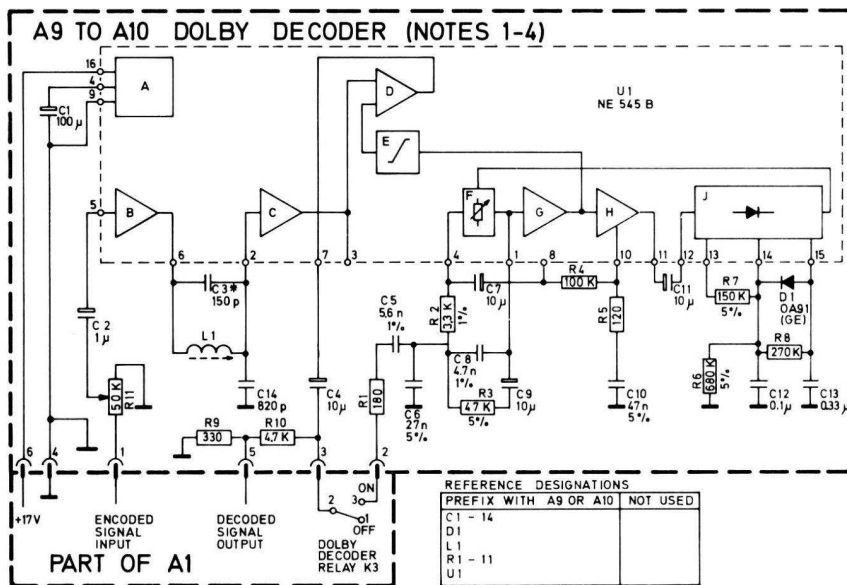

NOTES

1. UNLESS OTHERWISE SPECIFIED RESISTANCE IN OHMS
2. WHEN REFERRING TO A COMPONENT ON A PRINTED BOARD ASSEMBLY PUT THE ASSY DESIGNATION IN FRONT OF THE COMPONENT REFERENCE DESIGNATION (EG SPECIFY A9R1 AND NOT ONLY R1)
3. ALL SWITCH AND RELAY CONTACTS ARE SHOWN IN THE "POWER OFF" POSITION
4. A9 IS USED FOR THE LEFT CHANNEL WHILE A10 IS USED FOR THE RIGHT CHANNEL.

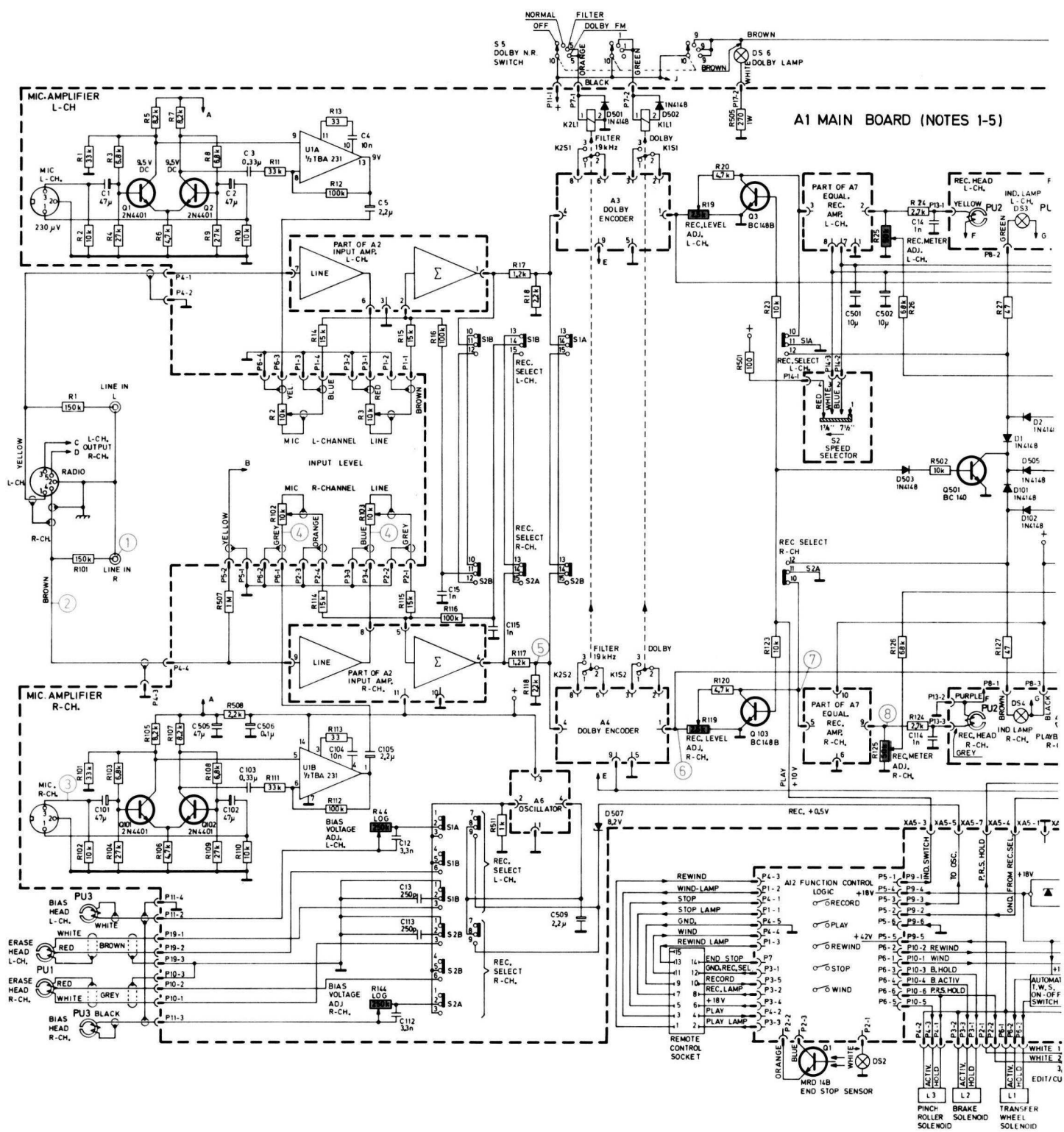

ALL THE SWITCHES ARE SEEN FROM SOLDER SIDE (NOTE 2 AND 3)

REFERENCE DESIGNATIONS	
NO PREFIX	PREFIX WITH A1
A1 - A12	C1-5, 101-105, 501-506
R1 - 3	D1-3, 101-103, 501-507
D51 - 6	K1-3
L1 - 3	Q1-5, 101-106, 501
M1 - 2	RH44, 101-144, 501-501
PU1-4	S1-4
SW1-7	U1

COMPONENTS CHANGED					
REF DESIGN	FROM	TO	DATE	E.C.O. NO	SERIAL NO
R1,101	150k	68k			ON US VER- SION ON US VER- SION
C1		1.2µF			

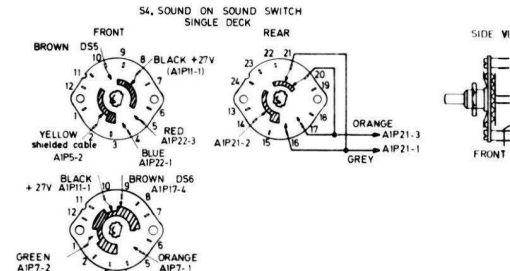
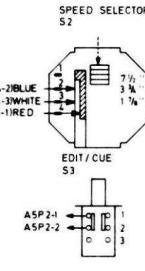
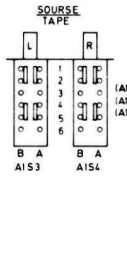
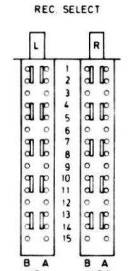

CONTINUED ON PAGE 50

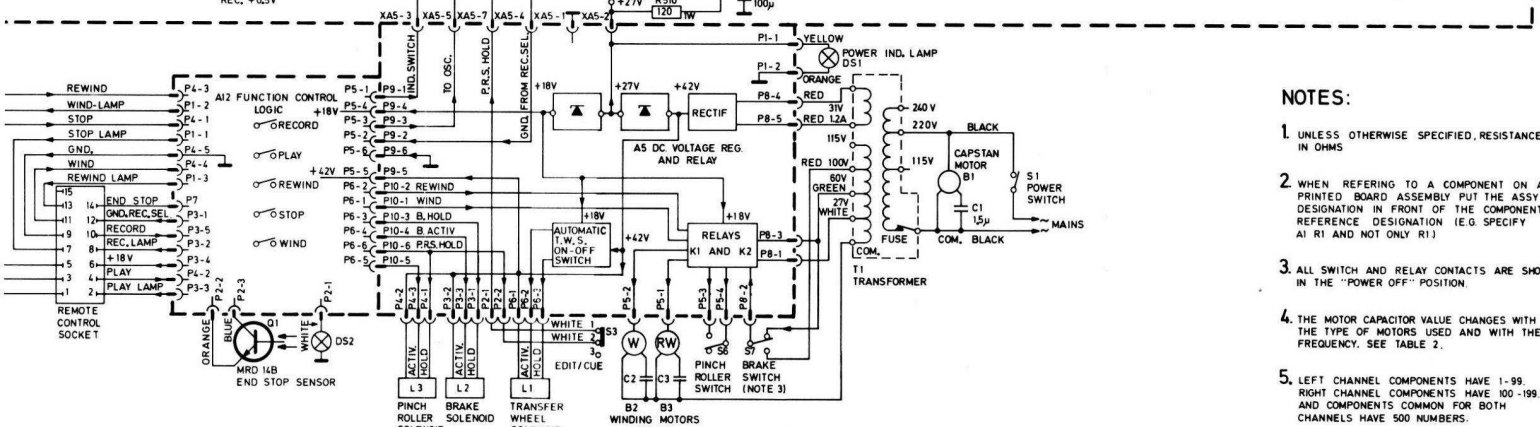
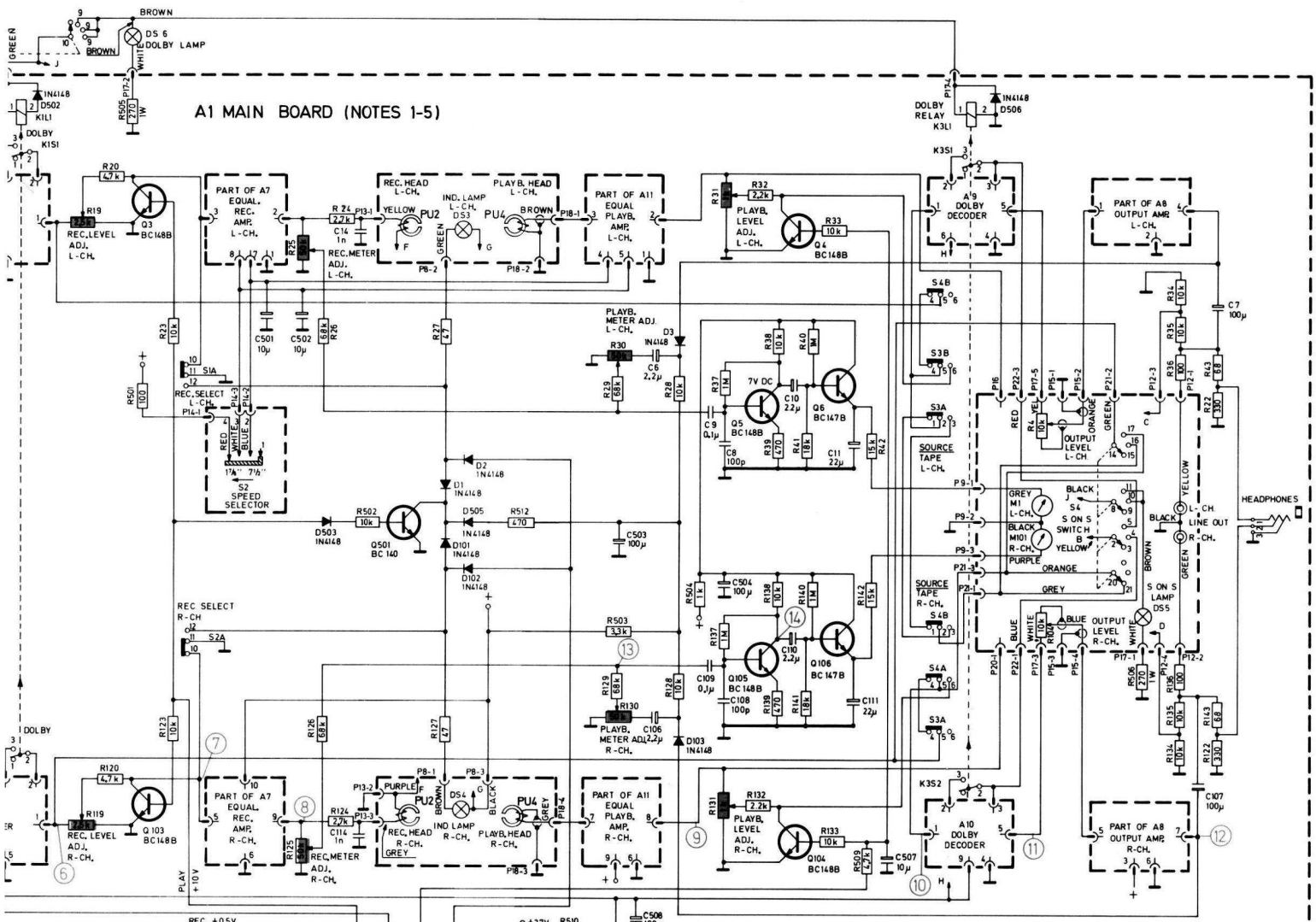

- NOTES:**
- UNLESS OTHERWISE SPECIFIED, RESISTANCE IN OHMS
 - WHEN REFERRING TO A COMPONENT ON A PRINTED BOARD ASSEMBLY PUT THE ASSY DESIGNATION IN FRONT OF THE COMPONENT REFERENCE DESIGNATION (E.G. SPECIFY A1 R1 AND NOT ONLY R1)
 - ALL SWITCH AND RELAY CONTACTS ARE SHOWN IN THE "POWER OFF" POSITION.
 - THE MOTOR CAPACITOR VALUE CHANGES WITH THE TYPE OF MOTORS USED AND WITH THE FREQUENCY. SEE TABLE 2.
 - LEFT CHANNEL COMPONENTS HAVE 1-99. RIGHT CHANNEL COMPONENTS HAVE 100-199. AND COMPONENTS COMMON FOR BOTH CHANNELS HAVE 500 NUMBERS.

OLDER SIDE (NOTE 2 AND 3)

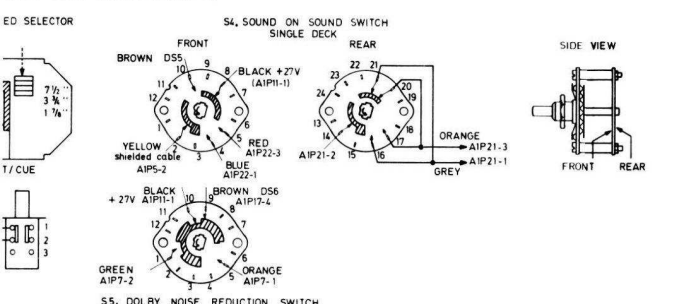

TABLE 1. SENSITIVITY OF AMPLIFIERS

L	R	SENSITIVITY AT 1000Hz AND 3 1/2 INCH SPEED
1	1	30mV
2	2	8mV
3	3	230 μV
4	4	30 mV
5	5	100 mV
6	6	80 mV
7	7	45 mV
8	8	13 V
9	9	190 mV
10	10	80 mV
11	11	85 mV
12	12	15 V
13	13	160 mV
14	14	2 V

TABLE 2. CAPASITOR AND VOLTAGE REQUIRMENTS FOR DIFFERENT WINDING MOTORS

M/RW MOTOR	50 Hz	60 Hz
RO 1465	2.8+0.7 μF	2.2 μF
HT 149	2.3+0.9 μF	2.3 μF
IB 942 R	4 μF	4 μF

A1 MAIN BOARD CIRCUIT DIAGRAM MODEL 9200XD

CONTINUED FROM PAGE 49

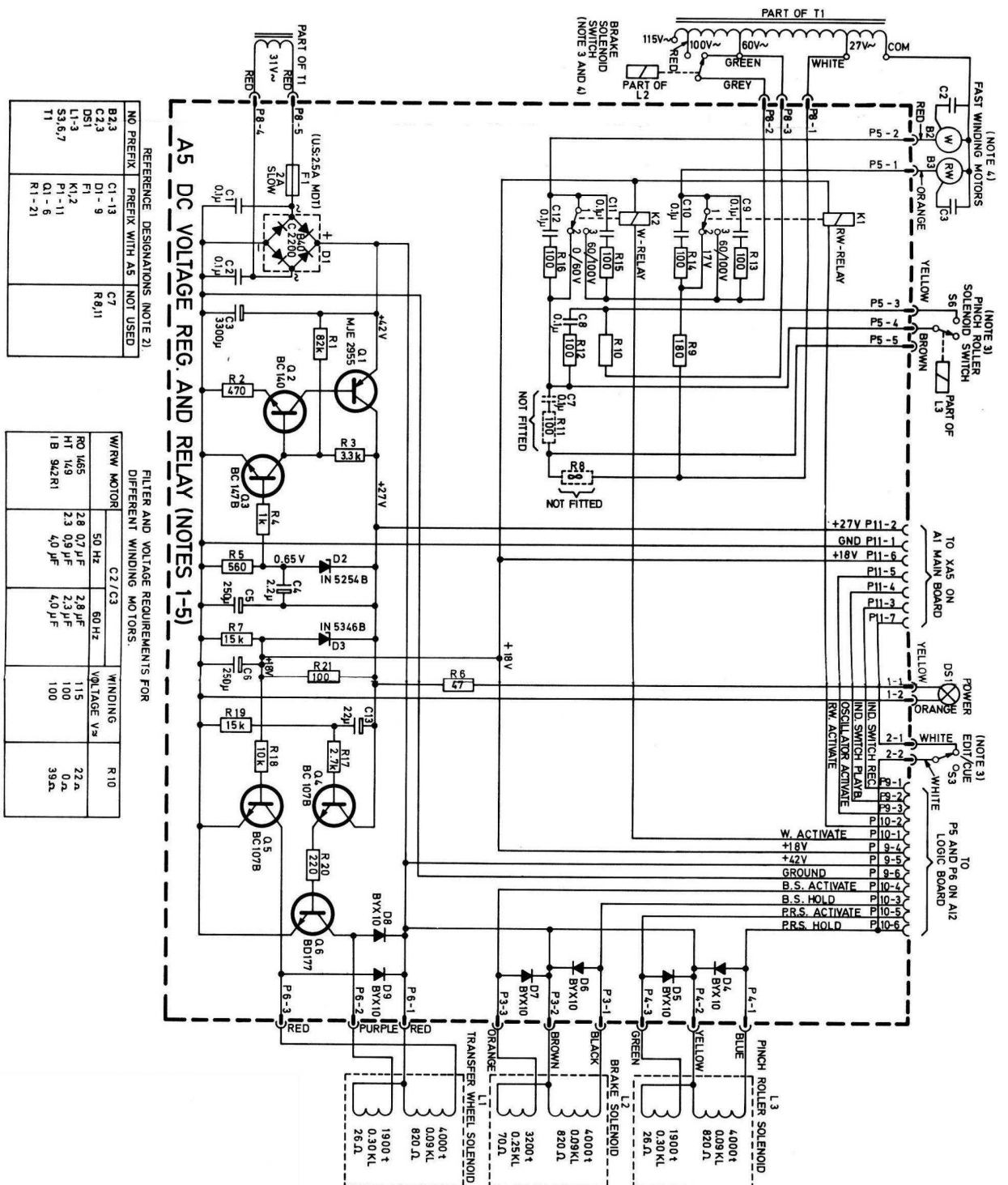

REFERENCE DESIGNATIONS (NOTE 2)

NO PREFIX	PREFIX WITH A5	NOT USED
R3	C1-13	C7
C2,3	D1-9	R8,11
D5	F1	
L1-3	K1,2	
S1,6,7	P1-11	
T1	Q1-6	
	R1-21	

FILTER AND VOLTAGE REQUIREMENTS FOR DIFFERENT WINDING MOTORS.

W/RW MOTOR	C2/C3	WINDING VOLTAGE V _W	R10
RO 1465	50 Hz	2.8 μF	115
HT 149	60 Hz	2.3 μF	100
IB 942R1		4.0 μF	100

NOTES:

1. UNLESS OTHERWISE SPECIFIED RESISTANCE IN OHMS.
2. WHEN REFERRING TO A COMPONENT ON A PRINTED BOARD ASSEMBLY PUT THE ASSY DESIGNATION IN FRONT OF THE COMPONENT REFERENCE DESIGNATION (E.G. SPECIFY A5R1 AND NOT ONLY R1).
3. ALL SWITCH AND RELAY CONTACTS ARE SHOWN IN THE "POWER OFF" POSITION. NOTE THAT THE BRAKE SOLENOID SWITCH IS MECHANICALLY ACTIVATED IN THE POWER OFF MODE AND ELECTRICALLY ACTIVATED IN THE STOP MODE.
4. THE WINDING VOLTAGE DEPENDS UPON THE MOTOR TYPE USED FOR FAST WINDING. R01465 REQUIRES 115V~ AND HT149 REQUIRES 100V~.
5. THE FILTER CAPACITOR VALUE CHANGES WITH THE TYPE OF MOTORS USED AND WITH THE FREQUENCY. SEE TABLE.

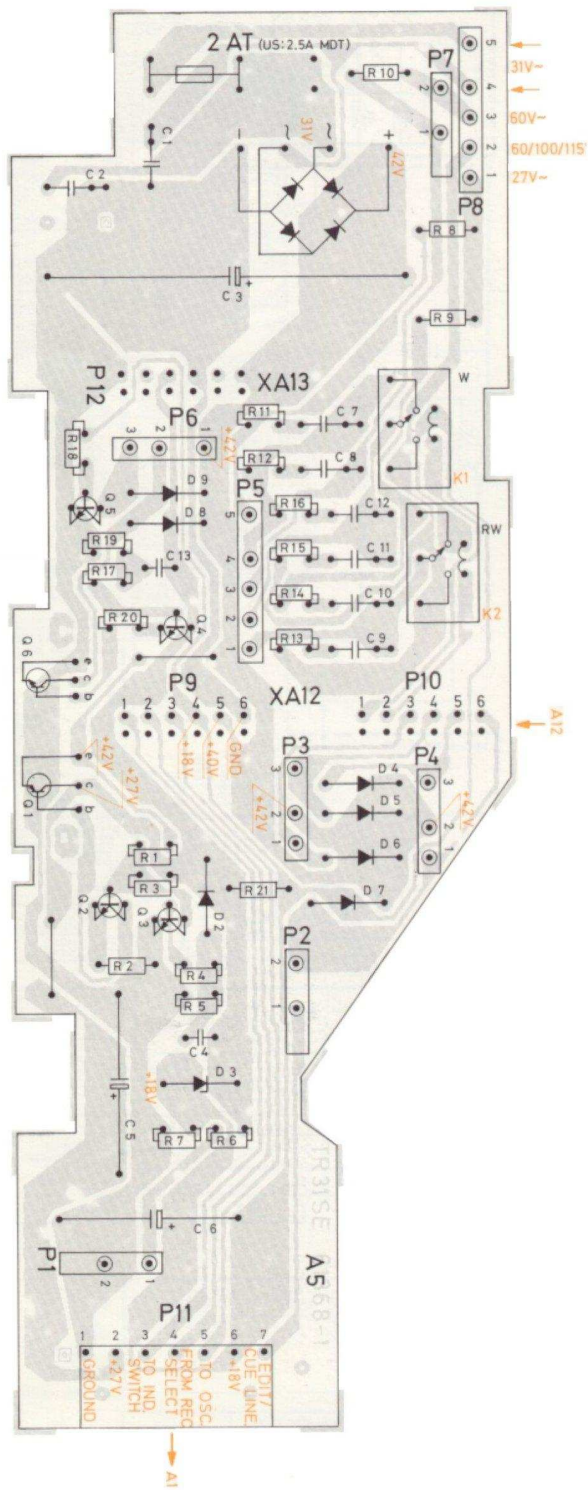

A5 DC VOLTAGE REG. AND RELAY BOARD. MODEL 9100X AND 9200XD

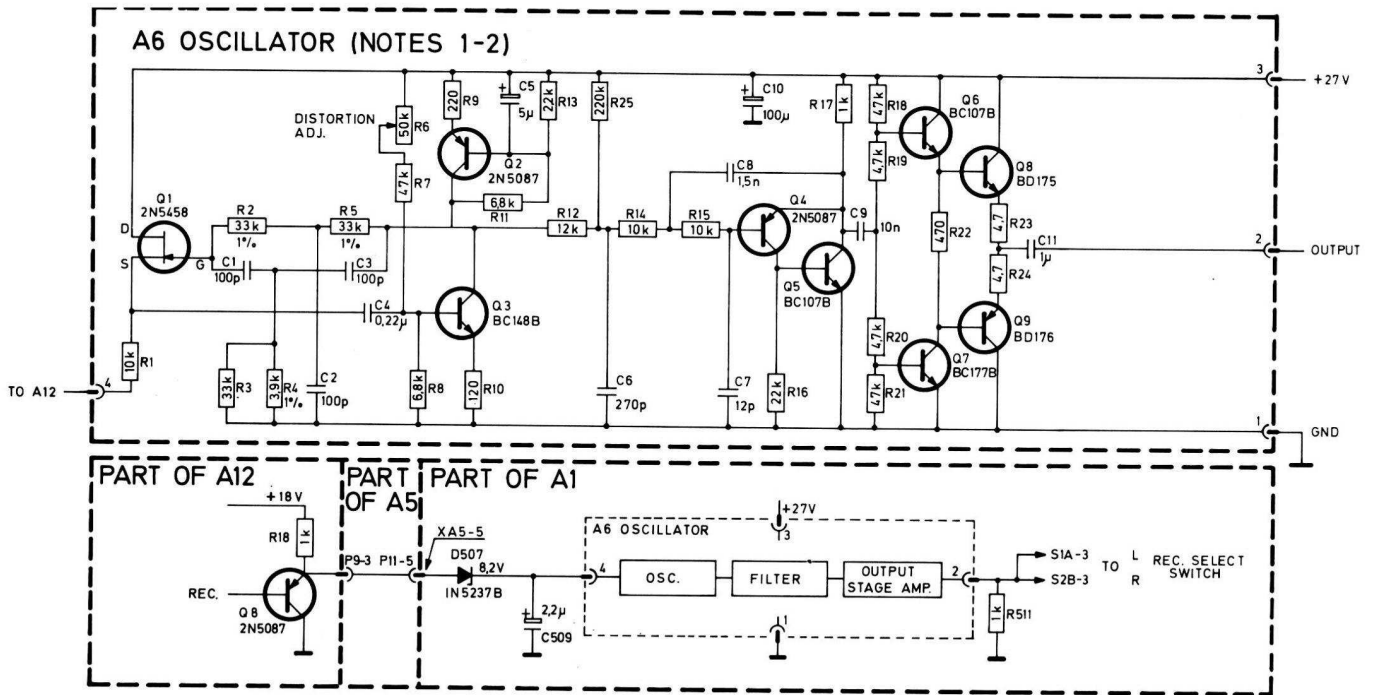

REFERENCE DESIGNATIONS

PREFIX WITH A6	NOT USED
C 1 - 11	
Q 1 - 9	
R 1 - 25	

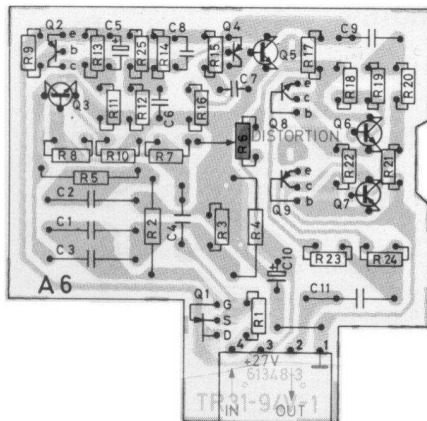

NOTES:

1. UNLESS OTHERWISE SPECIFIED RESISTANCE IN OHMS.
2. WHEN REFERRING TO A COMPONENT ON A PRINTED BOARD ASSEMBLY PUT THE ASSY DESIGNATION IN FRONT OF THE COMPONENT REFERENCE DESIGNATION (E. G. SPECIFY A6R1 AND NOT ONLY R1).

**A6 OSCILLATOR BOARD
MODEL 9100X AND 9200XD**

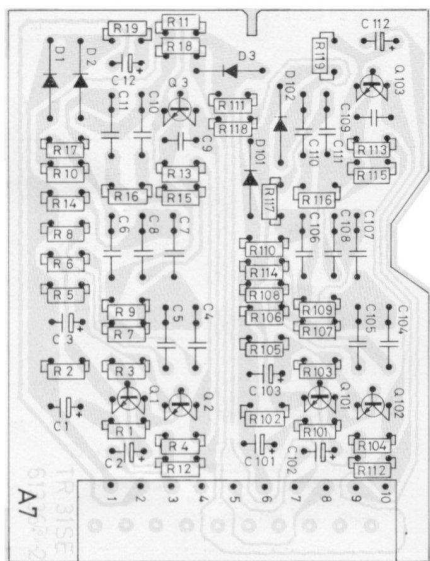
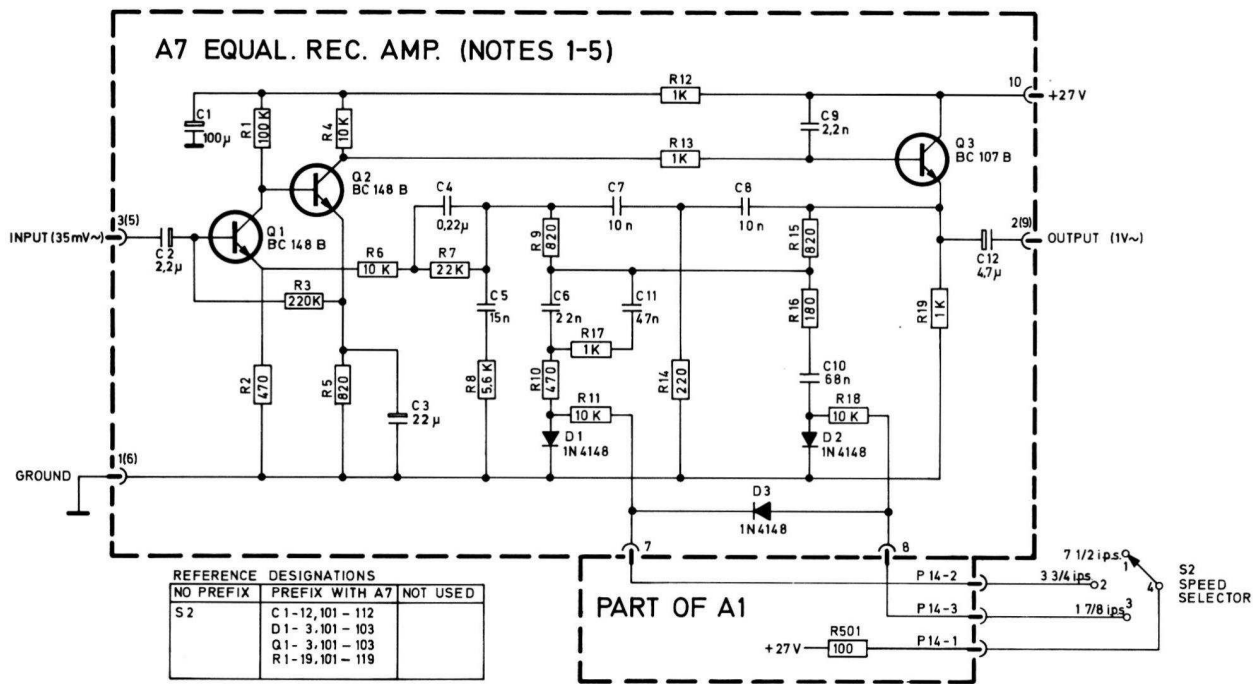

NOTES

1. UNLESS OTHERWISE SPECIFIED RESISTANCE IN OHMS.
2. WHEN REFERRING TO A COMPONENT ON A PRINTED BOARD ASSEMBLY PUT THE ASSY DESIGNATION IN FRONT OF THE COMPONENT REFERENCE DESIGNATION (E.G. SPECIFY A7R1 AND NOT ONLY R1).
3. ONLY THE L-CHANNEL OF THE ASSEMBLY DESIGNATED A7 IS SHOWN.
4. PLUG TERMINAL NO'S FOR THE R-CHANNEL ARE GIVEN IN BRACKETS BESIDE THE L-CHANNEL PLUG TERMINAL NO'S.
5. L-CHANNEL HAS 1-99 AND R-CHANNEL HAS 100-199 AS COMPONENT NO'S. WHEN REFERRING TO R-CHANNEL COMPONENTS ADD 100 TO THE L-CHANNEL NO'S (E.G. R17 OF THE L-CHANNEL HAS THE SAME VALUE AS R117 OF THE R-CHANNEL).

**A7 EQUAL. RECORD AMP.
MODEL 9100X AND 9200XD**

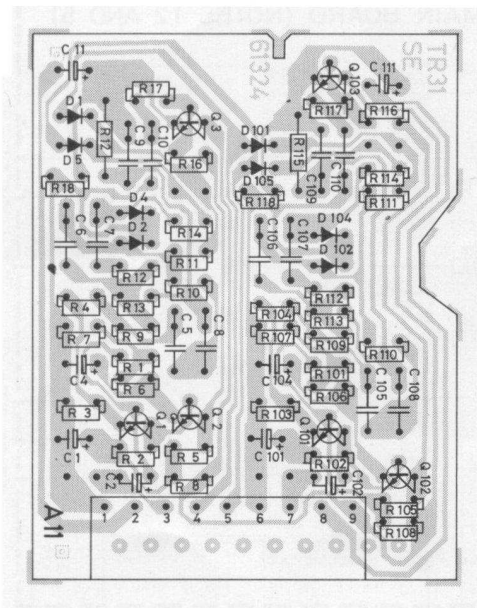
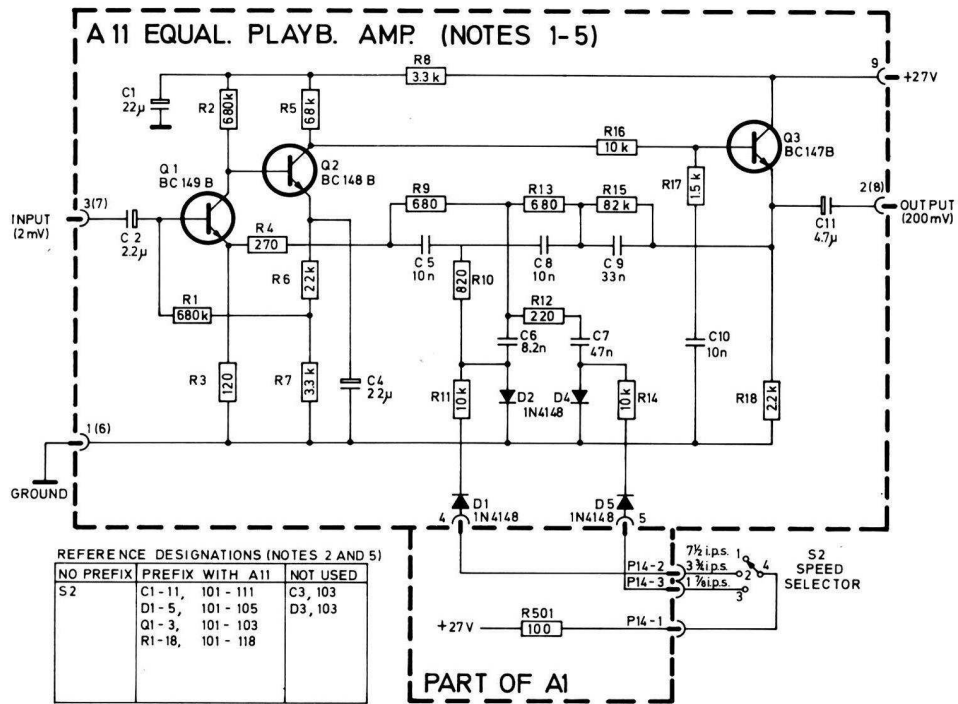

NOTES:

1. UNLESS OTHERWISE SPECIFIED RESISTANCE IN OHMS.
2. WHEN REFERRING TO A COMPONENT ON A PRINTED BOARD ASSEMBLY PUT THE ASSY DESIGNATION IN FRONT OF THE COMPONENT REFERENCE DESIGNATION (E. G. SPECIFY A11R1 AND NOT ONLY R1)
3. ONLY THE L-CHANNEL OF THE ASSEMBLY DESIGNATED A11 IS SHOWN.
4. PLUG TERMINAL NO.'S FOR THE R-CHANNEL ARE GIVEN IN BRACKETS BESIDE THE L-CHANNEL PLUG TERMINAL NO.'S.
5. L-CHANNEL HAS 1-99 AND R CHANNEL HAS 100-199 AS COMPONENT NO.'S. WHEN REFERRING TO R-CHANNEL COMPONENTS, ADD 100 TO THE L-CHANNEL NO.'S (E. G. R17 OF THE L-CHANNEL HAS THE SAME VALUE AS R117 OF THE R-CHANNEL).

**A11 EQUAL. PLAYBACK AMP.
MODEL 9100X AND 9200XD**



TANDBERGS RADIOFABRIKK A/S
Postboks 9, Korsvoll, Oslo 8
Norway

1232 - 5 - 76 Part No. 715101
Printed in Norway by Petlitz