

TANDBERG

TR 2075 MkII / TR2080

Service Manual

Contents

	Page
Changing and cleaning P/B selectors (switches)	2
Mechanical service	3
AM alignment procedure	4
AM circuit diagram	5
FM alignment procedure	6
FM circuit diagram – Stereo decoder diagrams	9
RIAA/input – P/B selectors, circuit diagram	11
Pre-Amp/Filter – Mode/Filter, circuit diagram	13
Power-Amplifier, circuit diagram	15



CHANGING OR CLEANING PUSH BUTTON SWITCHES

Occasionally the push button switches will need to be cleaned and lubricated to maintain trouble free action. A good cleaning agent should be applied sparingly with a fine brush. We recommend "Tandberg Klüberfett" or "Wählerfett" from our Service Department.

Alcohol or methylated spirit may also be used for cleaning, and vaseline may be used for lubrication afterwards.

NOTE! Avoid touching the contacts with your finger – it could cause corrosion.

Avoid using cleaning agents that could attack the metal parts.

NOTE! We have developed our own cleaning/lubricating agent, "Tandberg Contact Spray" in aerosols, and we recommend it for all types of contacts. These aerosols can be supplied from our district offices and subsidiary companies.

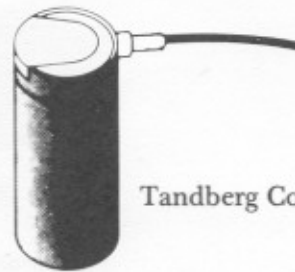

Tandberg Contact Spray

NOTE! Slide switches (mode selectors) are available complete as a replacement part.

If necessary, the switch can be cleaned, and the plunger or the contact unit can be changed. For these operations the switch must be dismantled.

DISMANTLING THE PLUNGER

- Pull the spring slightly forward so that the locking clip is free at the edge.
- Use tweezers as shown in the figure.
- Press the plunger right in. Push the locking clip backwards and lift it up.
NB! The locking pin lies loose in the locking clip.
- The plunger can be pulled out.
NB! The spring contact on the plunger are loose.

The spring is slightly conical so that if you remove it from the plunger, take care to replace it with the smallest end against front of the plunger.

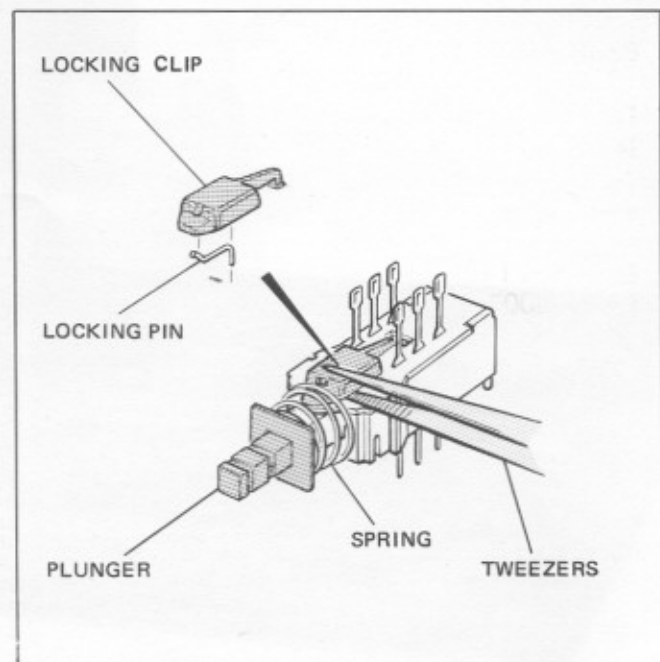

OUTPUT TRANSISTORS

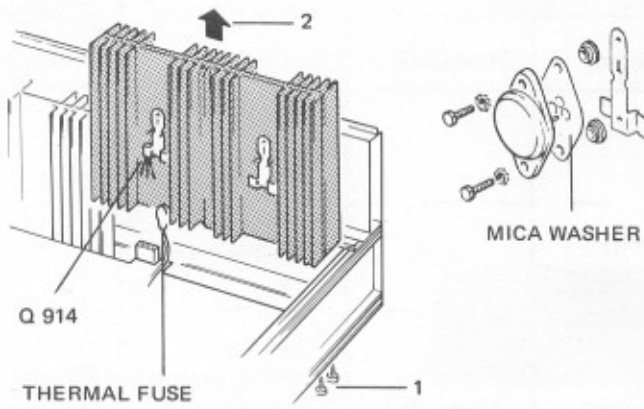

When changing the output transistors you should remove the complete corrugated heat sink for the channel in question.

1. Remove the 2 screws in the heat sink from underneath.
2. Pull the heat sink up.

NOTE! Q914 will come with the heat sink as it is pulled up, but the thermal fuse will remain hanging on the AF board.

NOTE! When assembling the output transistors we recommend to use "Thermal Compound Wakefield" on both sides of the mica washer. See Figure.

The compound can be obtained from our Service Dept. Use ordering No. 340245.

We do not recommend the use of "Silicon grease". If you must use Silicon grease, do not get it on the solder joints.

FM STEREO LAMP

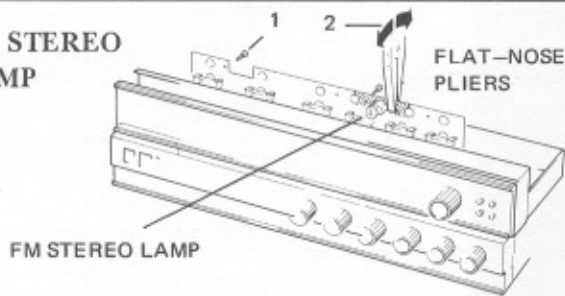

NOTE! The lamp unit and its lead are designed to be separated from the scale lamp board by a snap action.

1. Remove the four screws in the scale lamp board.
2. Loosen the board slightly so that you can insert a pair of flat-nose pliers beside the lamp. See Figure.

The scale lamp board and the stereo lamp are separately mounted.

NOTE! When removing the complete scale lamp board, you must first remove the screws on the MF/IF Tuner board.

SCALE DRIVE CORD

Before fitting a new drive cord you should loosen the screws on the AM board and pull off the leads so that the board is free.

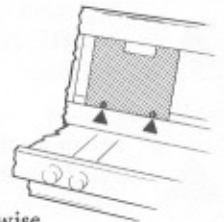

- Turn the pot. meter fully anti-clockwise.
- Pull cord end A through hole C from the back side. Pull cord end A until the eyelet on the cord comes out to the front side of hole C. Tape the cord securely as shown in the Figure.
- Lay cord end B in slot B in the cord wheel, then lay it in the back groove of the cord wheel and take 1 turn *anti-clockwise*. Tape the cord securely as shown in the Figure.
- Remove the tape from cord end A and lay the cord in slot A in the cord wheel. Then lay the cord in the front groove of the cord wheel and take 4 turns *clockwise*. Tape the cord again.
- Re-assemble the boards and the leads.
- Release the ends of the cord from the tape and complete the fitting of the cord as shown in the Figure.
- Assemble the scale pointer as shown in the Figure and set to the correct position on the scale.

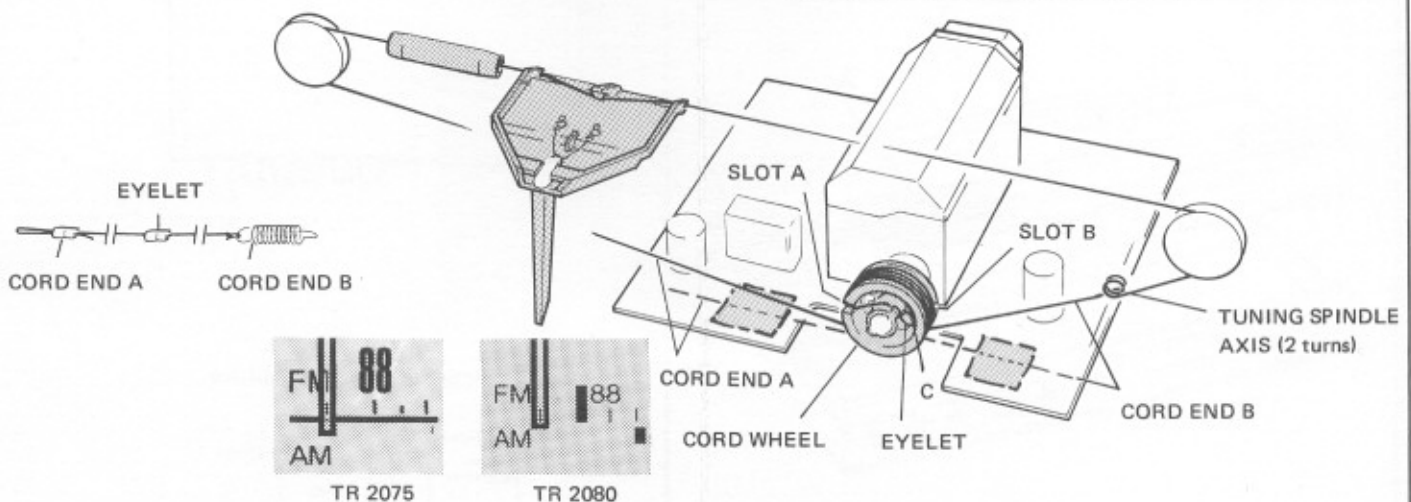

AM-ALIGNMENT PROCEDURE

Procedure	Receiver	Generator			Oscilloscope	Fre
	Frequency	Frequency	Modulation	Applied to M	Connected to M	Conn
1 A Oscilloscope with frequency counter <hr/> 1 B Oscillator	600 kHz 1400 kHz	600 kHz 1400 kHz	30%	* M3 via dummy ant. (Fig. 4)		M2, circu
2 A AM-IF with wobbler <hr/> 2 B AM-IF without wobbler	1400 kHz	Wobb.freq. — 1400 kHz	Unmodul.	* M3 via wobbler and dummy ant. (Fig. 3-4)	M1, see circuit diagram	
3 A Antenna circuit, ferrite and HF circuit with wobbler <hr/> 3 B Antenna circuit, ferrite and HF circuit without wobbler	600 kHz 1400 kHz	Wobb.freq. — 600 kHz 1400 kHz	Unmodul.	* M3 via wobbler and dummy ant. (Fig. 3-4)	M1, see circuit diagram	
4 Signal meter	1 MHz	1 MHz	30%	* M3 at/20 mV		

Fig. 1 Alignment point, L3

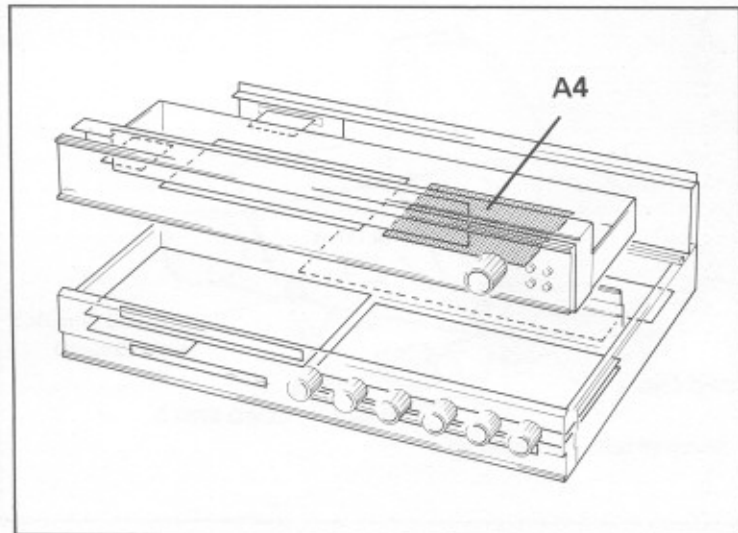
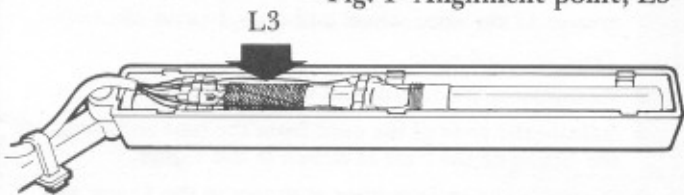

Fig. 2 Ferrite antenna

Adjust with ferrite ant. in position as shown in Figure.

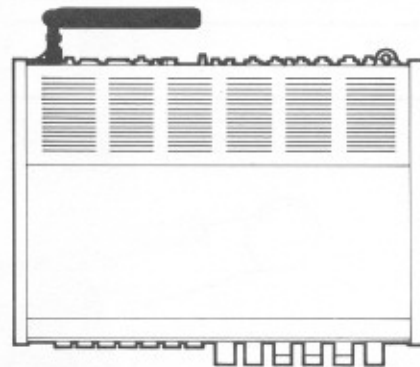
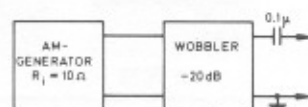

Fig. 3 Generator and wobbler



*M
**L

Frequency counter	Circuits	Notes
connected to M	Board No.	
M2, see circuit diagram	L401 C402	A4 If available, use a frequency counter to obtain max. accuracy. Use a calibrated signal generator. NOTE! Check the dial pointer zero position, see Fig. 5.
	L403 L404	A4 Adjust for max. curve height. See Fig. 6. The center frequency is determined by the fixed ceramic filter. Adjust for max. output.
	**L3 - L402 C410 - C417	A4 Adjust for max. curve height. Adjust for max. output.
	R405	A4 Adjust to 15 on TR2075 MK II Adjust to $10^2 \mu V$ on TR2080

*M3, Antenna input.

**L3, Antenna circuit, ferrite.

Fig. 4 Dummy antenna

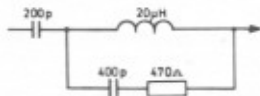
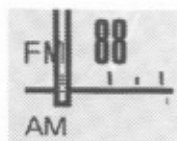
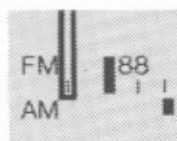

Fig. 5 Adjusting the dial pointer.
The end position of the scale cursor.
Note! Check FM scale accuracy.



TR 2075



TR 2080

Fig. 6 AM-IF with wobbler
Signal applied to M3 via Fig. 3-4.
Oscilloscope connected to M1

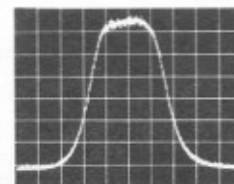

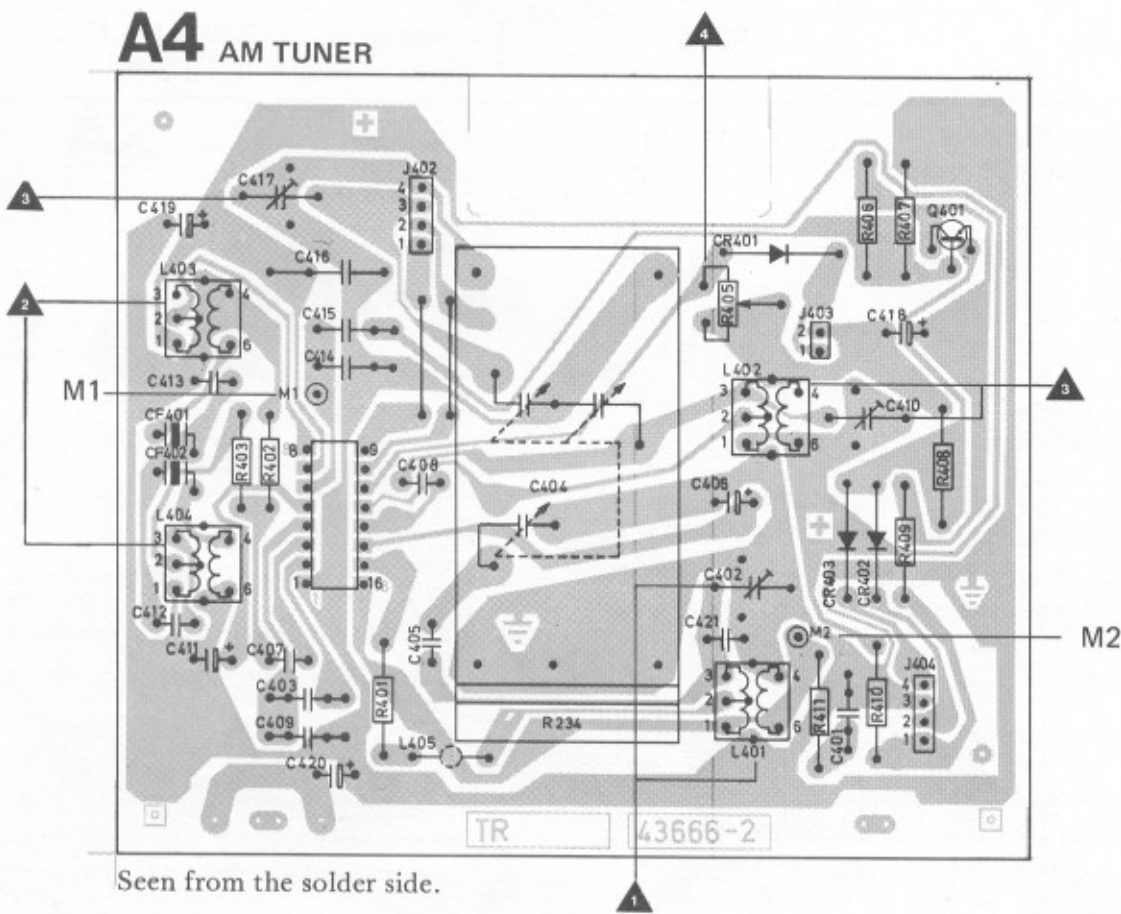
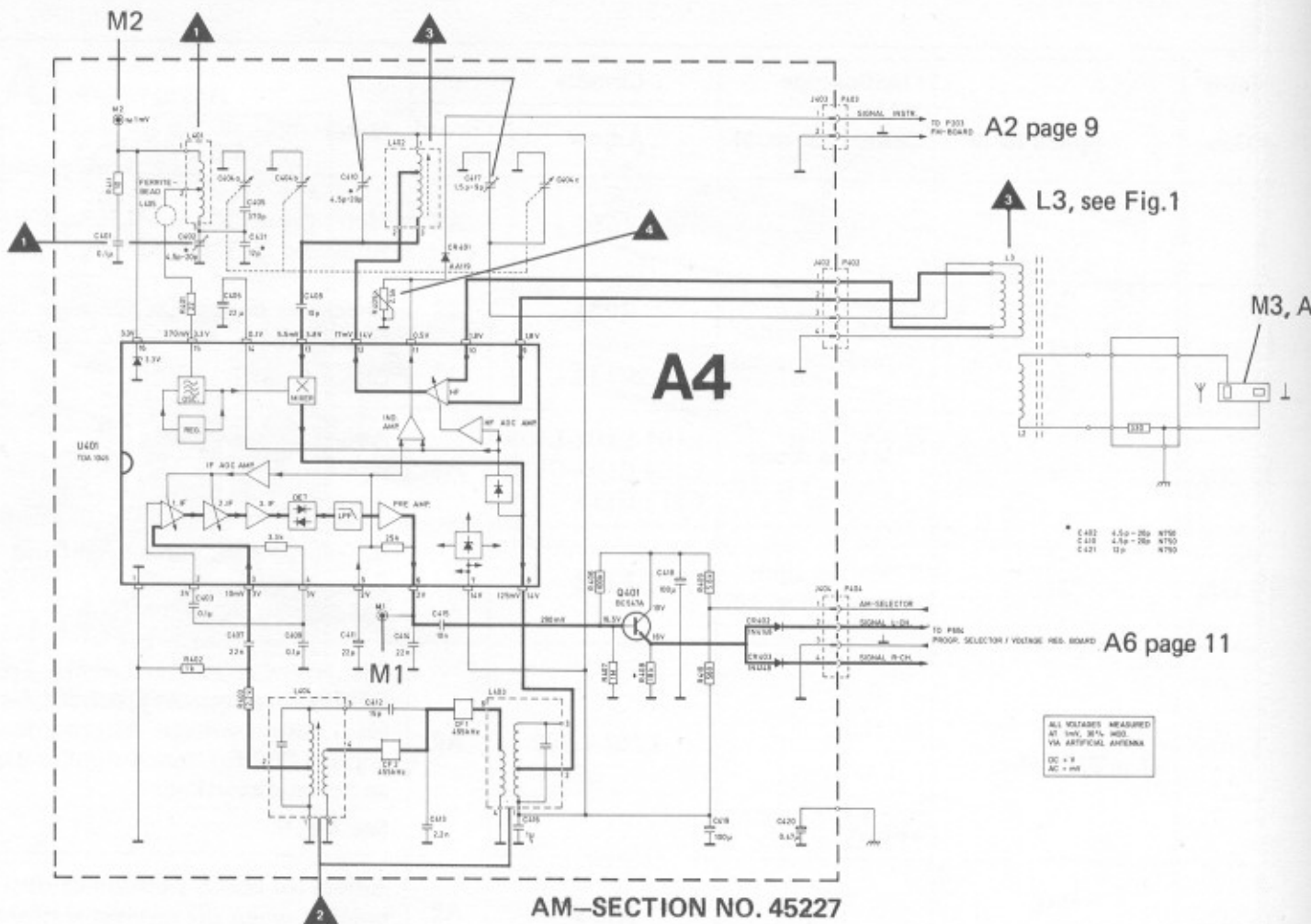

Seen from the solder side.

M3, Ant. input page 4.

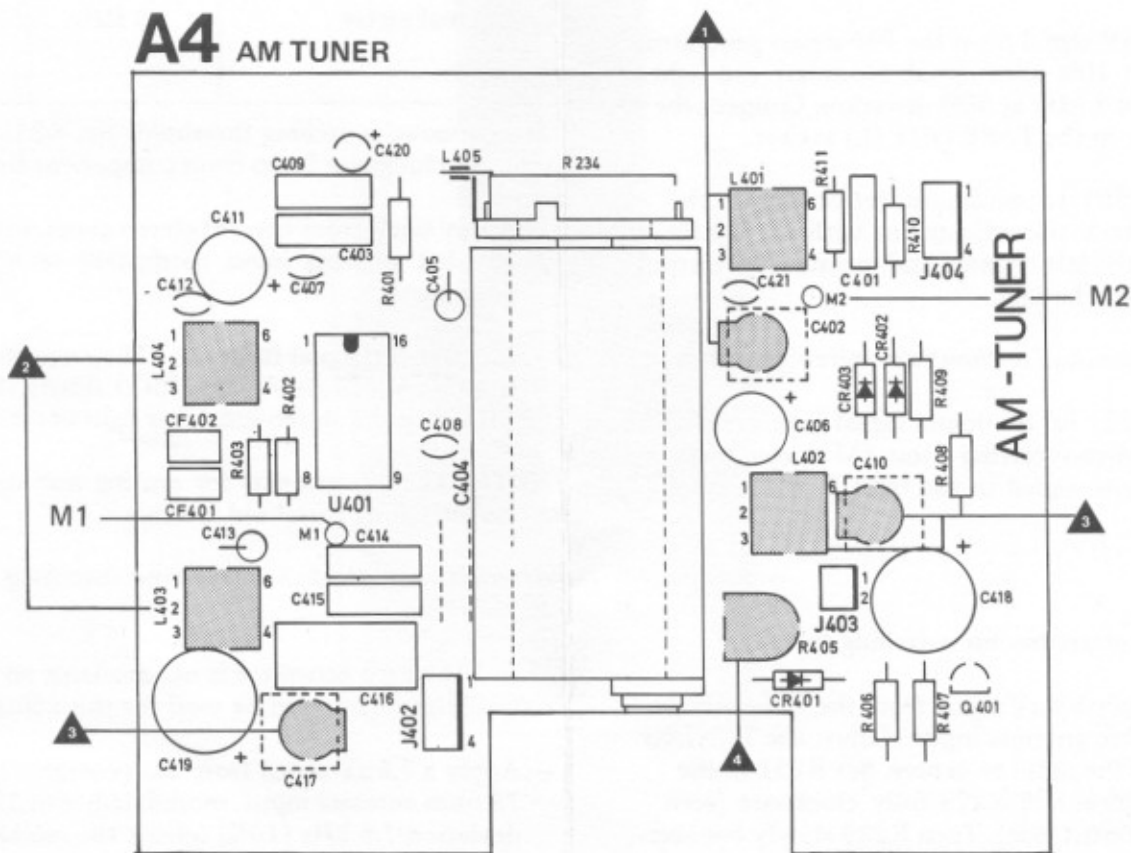
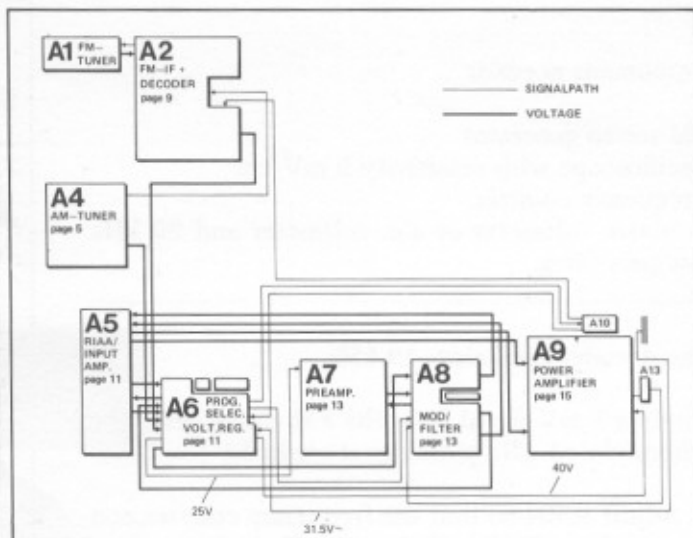

Seen from the component side.

ALIGNMENT OF STEREO DECODER

Equipment needed:

FM stereo generator
Oscilloscope with sensitivity 5 mV/cm
Frequency counter
Selective voltmeter or a.c. voltmeter and 20 kHz low pass filter.

The decoder oscillator: 19 kHz

Apply a 1 mV signal from the FM stereo generator, unmodulated. (No pilot signal applied.)

- Adjust R304 so that the frequency counter connected to M301 indicates 19 kHz.

Alternative method without the frequency counter:

Apply a 1 mV signal from the FM stereo generator, modulation: 10% pilot signal.

- Turn R304 slowly from one extreme to the point where the stereo indicator lights up. Turn further in the same direction until the light goes out. Then turn in the opposite direction to set R304 in the middle of the range where the indicator lights.

Channel separation:

Apply a 1 mV signal from the FM stereo generator, modulation: 10% pilot signal. Modulate the right channel with 1 kHz at 30% deviation. Connect the oscilloscope to the TAPE OUT (L) socket.

- Adjust R323 to minimum deflection on the scope. Check this adjustment with the 1 kHz signal in the left channel and measure the output of the right channel.

Alternative method without the stereo generator:

- Adjust R323 for minimum signal in left (right) speaker when receiving a test FM stereo, transmission with signal in the right (left) channel only.

Muting and stereo/mono switching threshold:

Muting: Apply a 3 μ V signal from the FM-generator to the 75 ohm antenna input. Adjust the TUNING METER on the radio to center. Set R231 in the middle position and R229 fully clockwise (seen from component side). Turn R229 slowly counter-clockwise until the signal is recovered.

FM alignment procedure

Step	Alignment procedure	Receiver		Generato
		Frequency	Frequency	Deviation
5 ^A	25 V for varicap			
5 ^B	FM oscillator	90 MHz 105 MHz	90 MHz 105 MHz	± 22.5 kHz
6	Aerial circuit	90 MHz 105 MHz	90 MHz 105 MHz	± 200 kHz
7	FM - IF	90 MHz	90 MHz	± 200 kHz
8	Discriminator	90 MHz	90 MHz	± 75 kHz
9	Center tuning meter	90 MHz	90 MHz	± 75 kHz
10 ^A B	Signal meter	90 MHz	90 MHz	± 0 kHz

Stereo/mono switching threshold: Set R231 fully counter clockwise (seen from component side).

- Apply 0 μ V from the FM stereo generator to the 75 ohm antenna input modulated with 10% pilot signal.

Increase the signal from the FM-stereo generator from 0 μ V to 7,5 μ V. Turn R231 slowly clockwise until the stereo-indicator light comes on.

NOTE! The adjustments for muting and stereo/mono switching threshold interact.

Alternative method: Stereo/mono switching threshold:

If an FM-stereo generator is not available an ordinary FM-generator can be used for this adjustment.

- Apply a 7,5 μ V signal from the generator to the 75 ohm antenna input, modulated with 10 kHz, deviation 7.5 kHz (10%) (check the modulation frequency with a counter). Proceed as explained above.

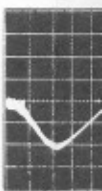
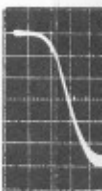

Generator		Oscilloscope	Circuits		Notes
Frequency	Applied to M	Connected to M	Adjust	Board No.	
			R616	A6	Meter connected to M13. A6 page 11. Adjust to 25 V d.c. reading.
5 kHz	*M1	**M4 via diode-probe. Fig. 10.	R204 C124	A2 A1	Check the position of the scale cursor (see Fig. 11). Check 95 MHz and 100 MHz.
10 kHz	*M1	**M4 via diode-probe. Fig. 10.	L101-L102-L103 L104,C104-C110 C112-C113	A1	Adjust for max. curve height (see Fig. 8).
10 kHz	*M1	**M4 via diode-probe. Fig. 10.	L107-L108	A1	Adjust for max. curve height and symmetry (see Fig. 8). FM - IF 10.6 - 10.8 MHz.
5 kHz	*M1 1 mV/75 ohm	***M5	L201-L202	A2	Dist./voltm. connected to M5, TAPE OUTPUT socket: Adjust L201 for max. output voltage. Afterwards adjust L202 for min. output voltage and min. distortion. See Fig. 9.
5 kHz	*M1 1 mV/75 ohm		R239	A2	Adjust for center position of the pointer, when the receiver is tuned to min. distortion. See step 8.
10 kHz	No signal. *M1, 1 mV/75 ohm		R236 R232	A2	Adjust to 0 on SIGNAL METER. Adjust to 20 on TR2075 MK II Adjust to $10^3 \mu\text{V}$ on TR2080

* Antenna input (A1) page 9.

** See FM-IF Section (A2) page 9.

*** See Audio Section 1 (A5) page 11.

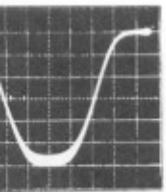

Fig. 8 FM-IF curve

Signal: $U_{in} = 150 \mu\text{V}/75 \text{ ohms}$, $f = 90 \text{ MHz}$.
Dev. = $\pm 200 \text{ kHz}$ applied to M1 via ant. plug.

Oscilloscope: Vert.: 5mV/div., Hor.: 50 kHz/div.
connected to M4 via diodeprobe (Fig. 10).

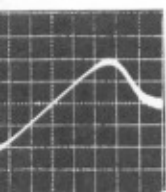

Fig. 9 Discriminator

Signal: $U_{in} = 2 \mu\text{V}/75 \text{ ohms}$, $f = 90 \text{ MHz}$.
Dev. = $\pm 200 \text{ kHz}$ applied to M1 via ant. plug.

Oscilloscope: Vert.: 1V/div. Hor.: 50 kHz/div.
connected to M5.

Fig. 10 Diodeprobe

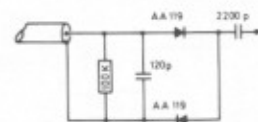
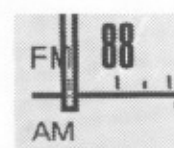
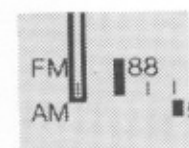

Fig. 11 Adjusting the dial pointer.
The end position of the scale cursor.



TR 2075



TR 2080

A1 FM-TUNER

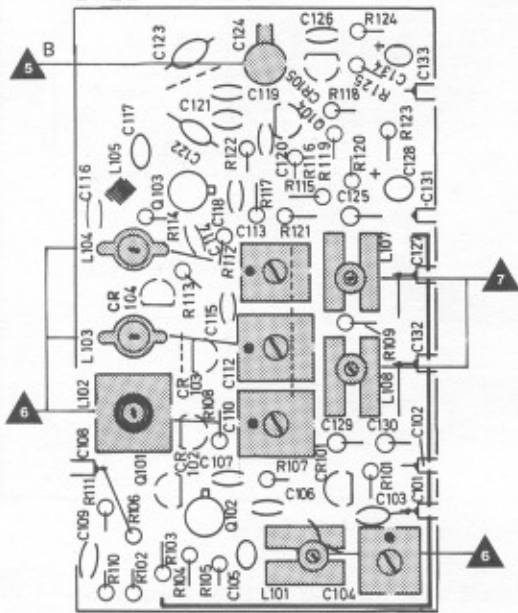

Seen from the component side.

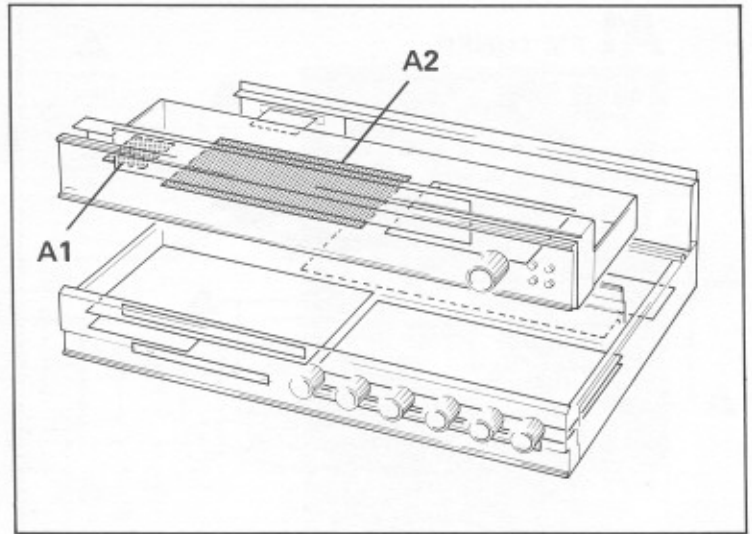

A2 FM-IF + DECODER

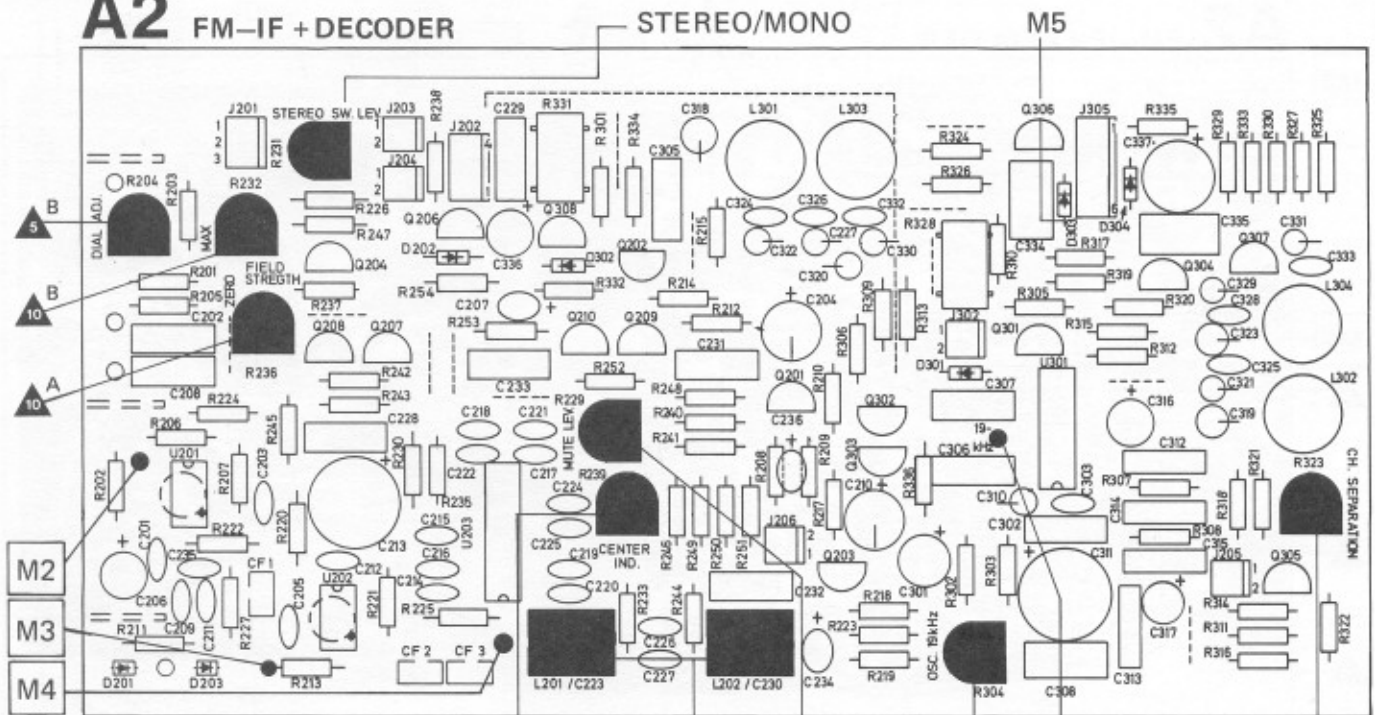

Seen from the component side.

MUTING 19 kHz OSC. M301 CHANNEL SEP.

A1 FM TUNER

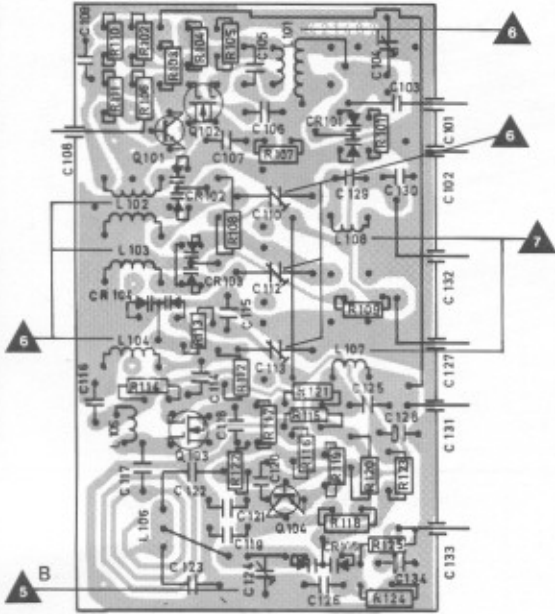

Seen from the solder side

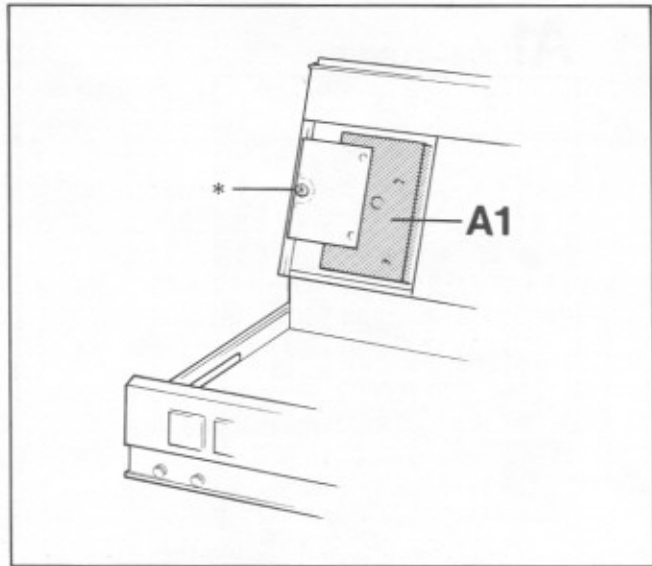

Fault finding on the FM TUNER

Turn the tuner unit up into vertical position.
 * Remove the screw shown in the figure.
 Remove the cover.

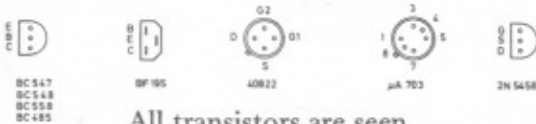

All transistors are seen from underneath

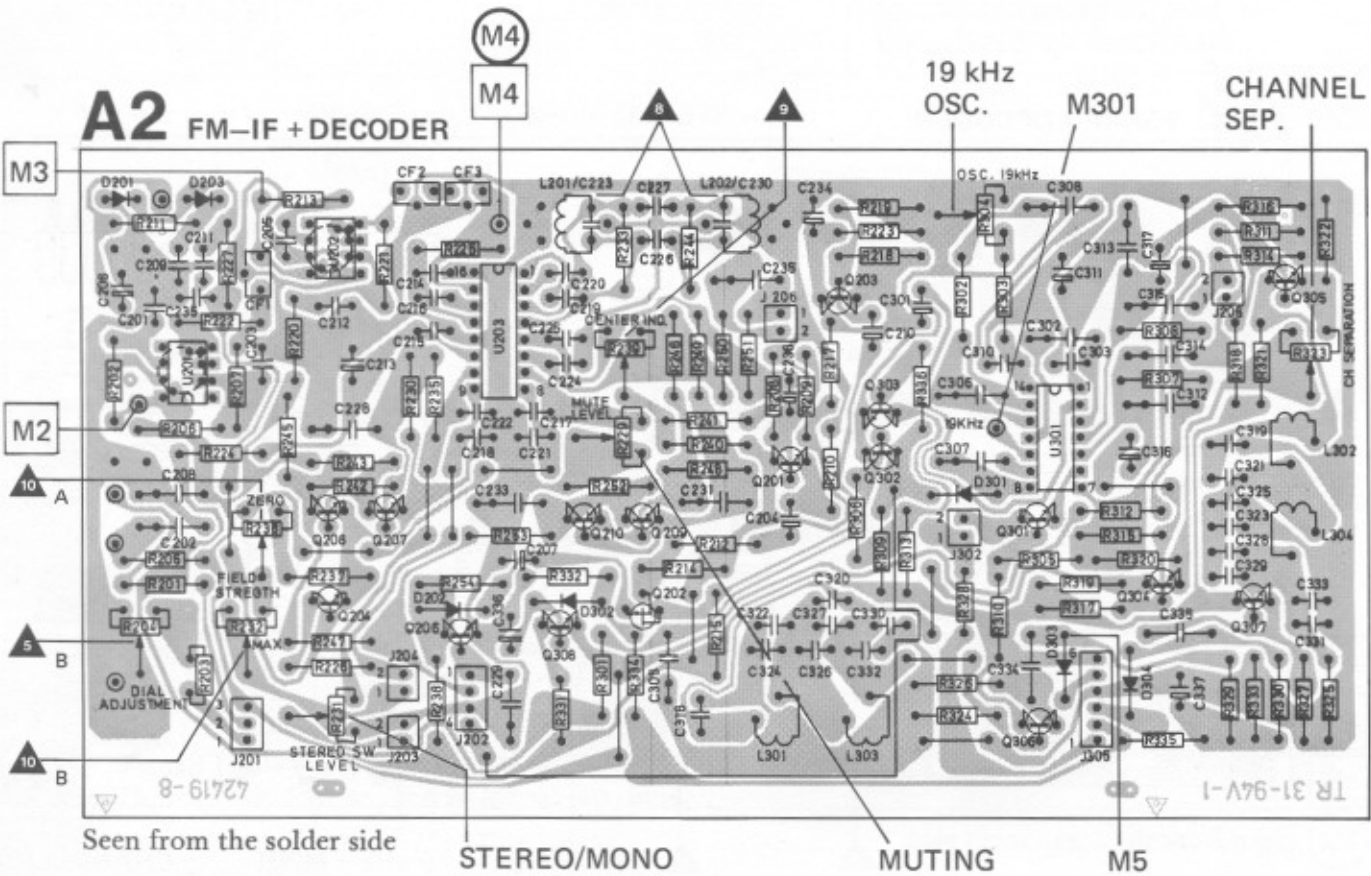

Seen from the solder side

M1 0.5 μ V/75 Ohms

M2 13

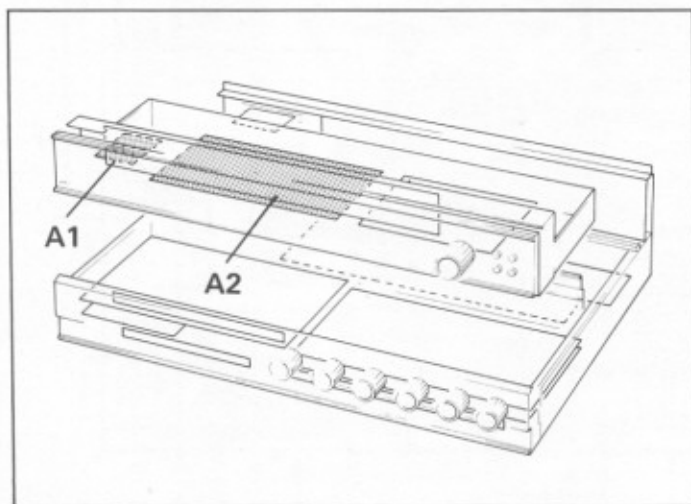
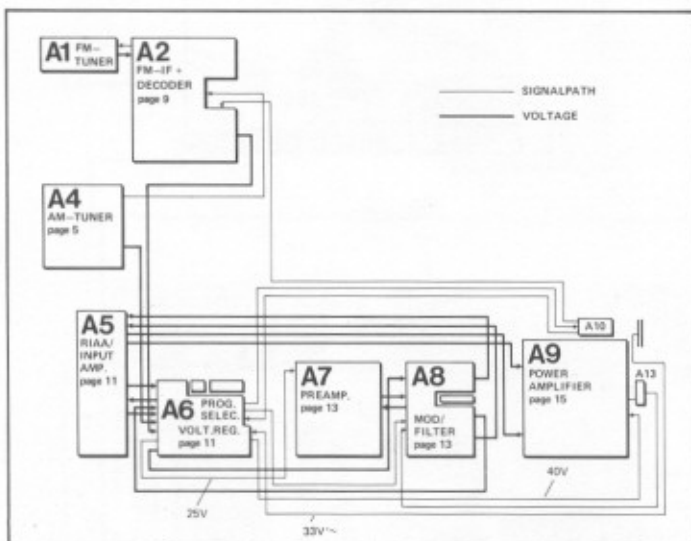
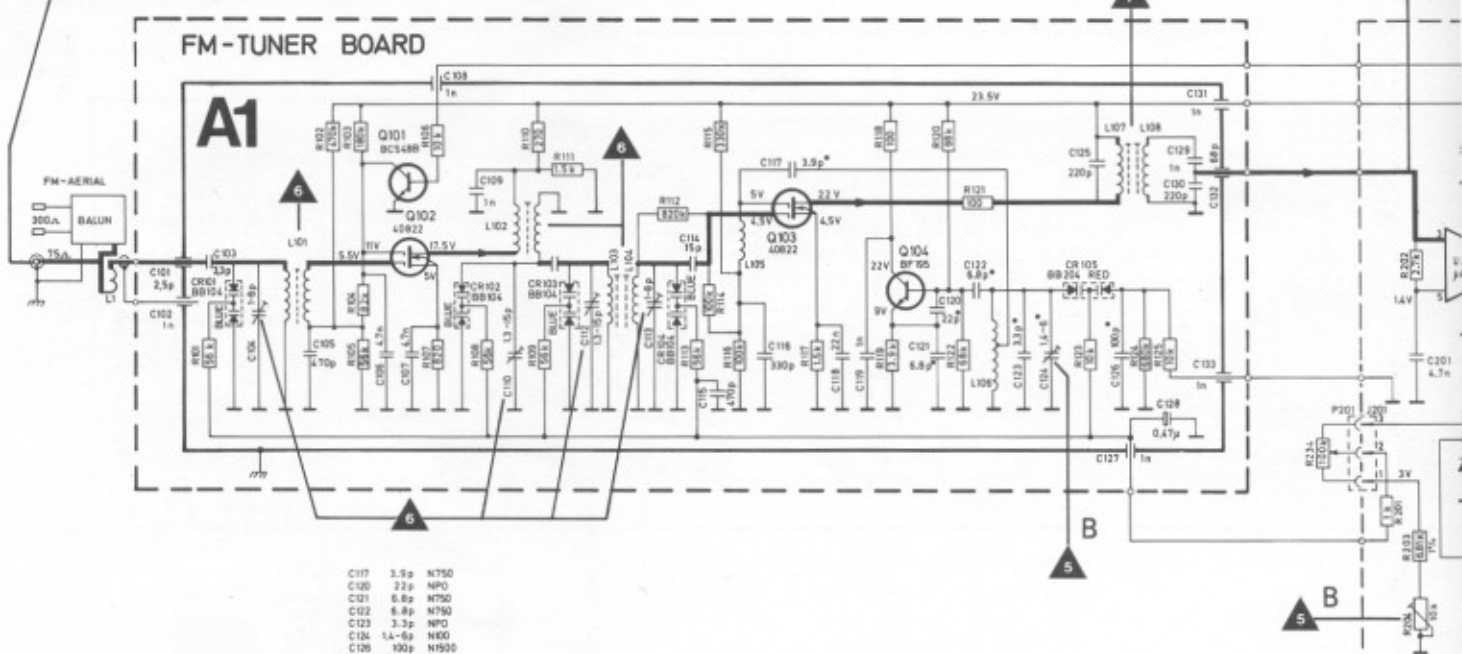

NOTE! The sensitivity measurements mentioned in the circuit diagram were made with a voltage divider in series with the sig. generator for M2, M3, and M4 (see figure below).

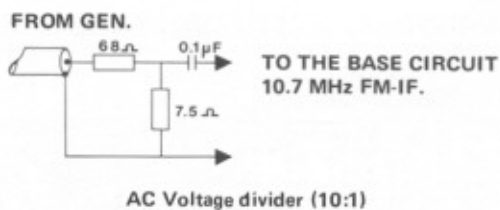

NOTE! The leads of the components in the voltage divider must be as short as possible.

THE MEASUREMENTS ARE MADE AS FOLLOWS:

- M5: Out max. AF voltage, reduced by 3 dB.
- M1: In 0.5 μ V from sig. generator, 100% modulation.
- M5: Out max. AF voltage, reduced by 3 dB.
- M2: In 130 μ V from sig. generator, 100% modulation.
- M5: Out max. AF voltage, reduced by 3 dB.
- M3: In 280 μ V from sig. generator, 100% modulation.
- M5: Out max. AF voltage, reduced by 3 dB.
- M4: In 200 μ V from sig. generator, 100% modulation.

NOTE! There can be a slight spread on the sensitivity measurement figures between different receivers.

- **NOTE!** When measuring only the sensitivity between M1 and M5 you can use the TAPE OUT (pin 1 or 4) socket as M5 to avoid dismantling the cabinet.

NOTE! When leading a signal from a sig. generator into the circuit, connect the generator positive and negative lead across the IC.

19 OSC

M2 130 μ V M3 280 μ V M4 M4 200 μ V

FM-IF + DECODER BOARD

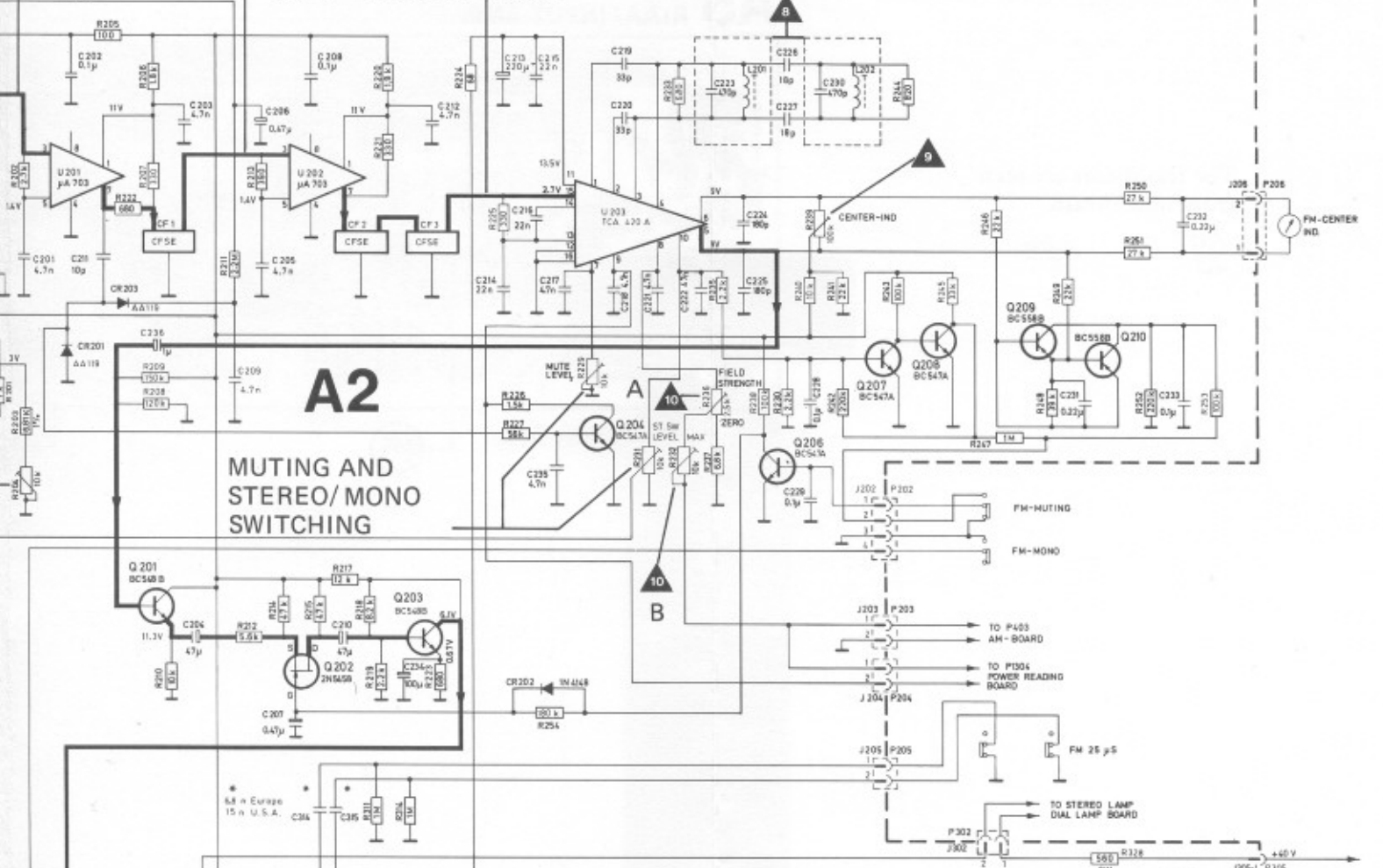

A2
MUTING AND
STEREO/MONO
SWITCHING

M301

CHANNEL SEPARATION

M5

Max.: AF O/P voltage -3 dB

FM-SECTION NO. 45226

19 kHz
OSC.

* R317 / R318: 100k EUROPA / 100k USA
* R320 / R322: 330 EUROPA / 360 USA

TR2080

A5 RIAA/ INPUT AMP.

The transistors are seen from underneath.

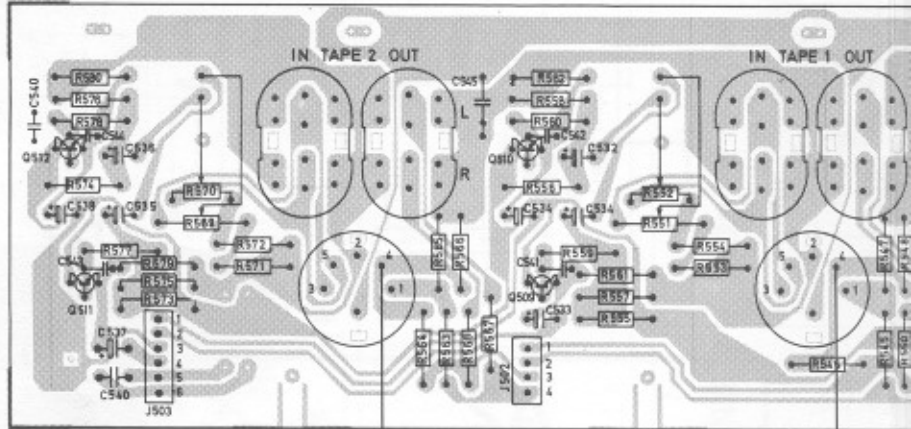

Seen from the solder side.

A6 PROGRAM SELECT/ VOLTAGE REG.

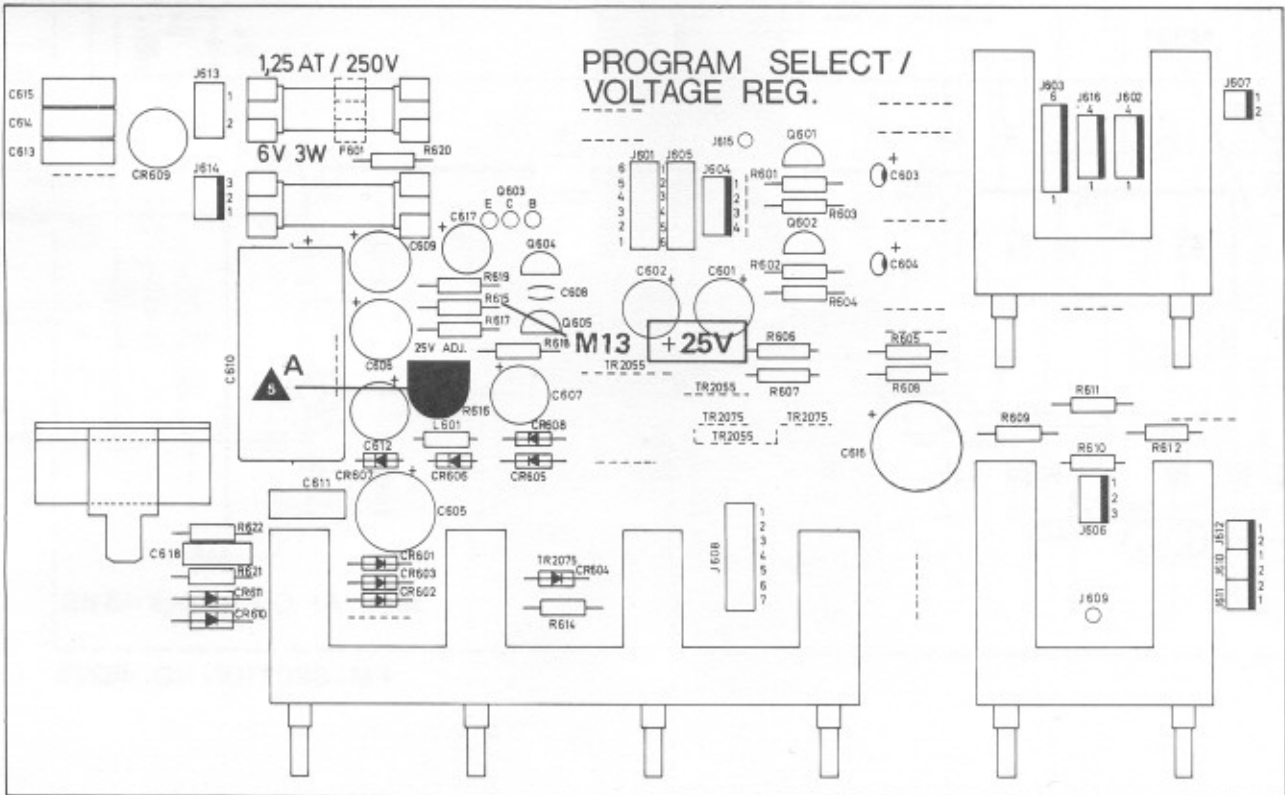

Seen from the component side.

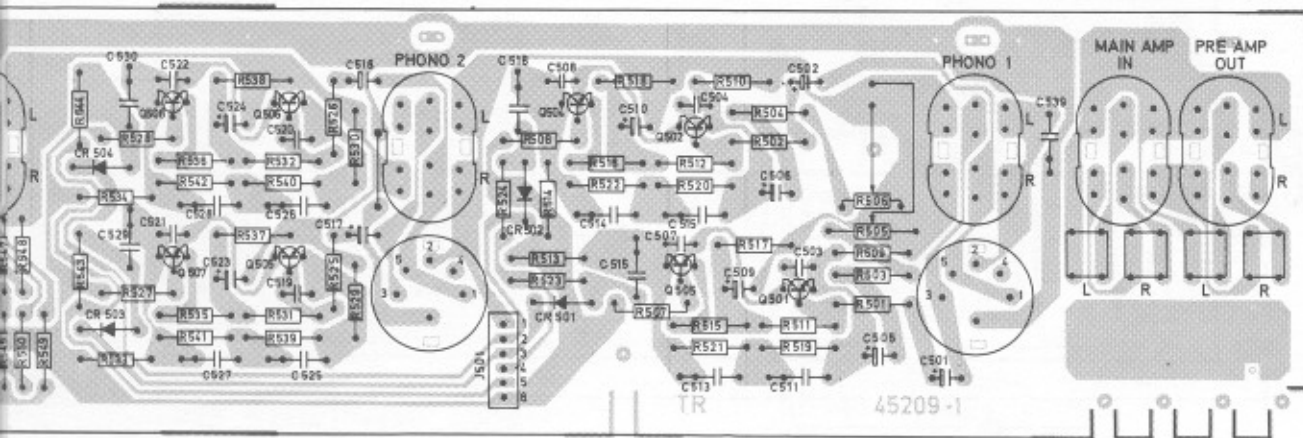

M5

" Pops " when switching
the POWER OFF.
See page 15.

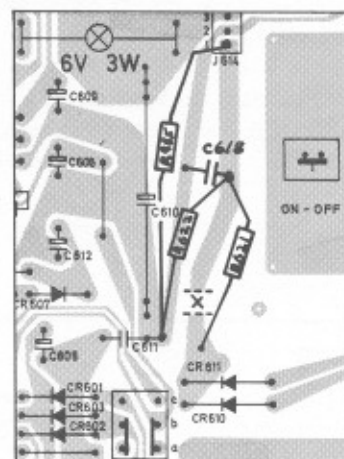

A6 PROGRAM SELECT/ VOLTAGE REG.

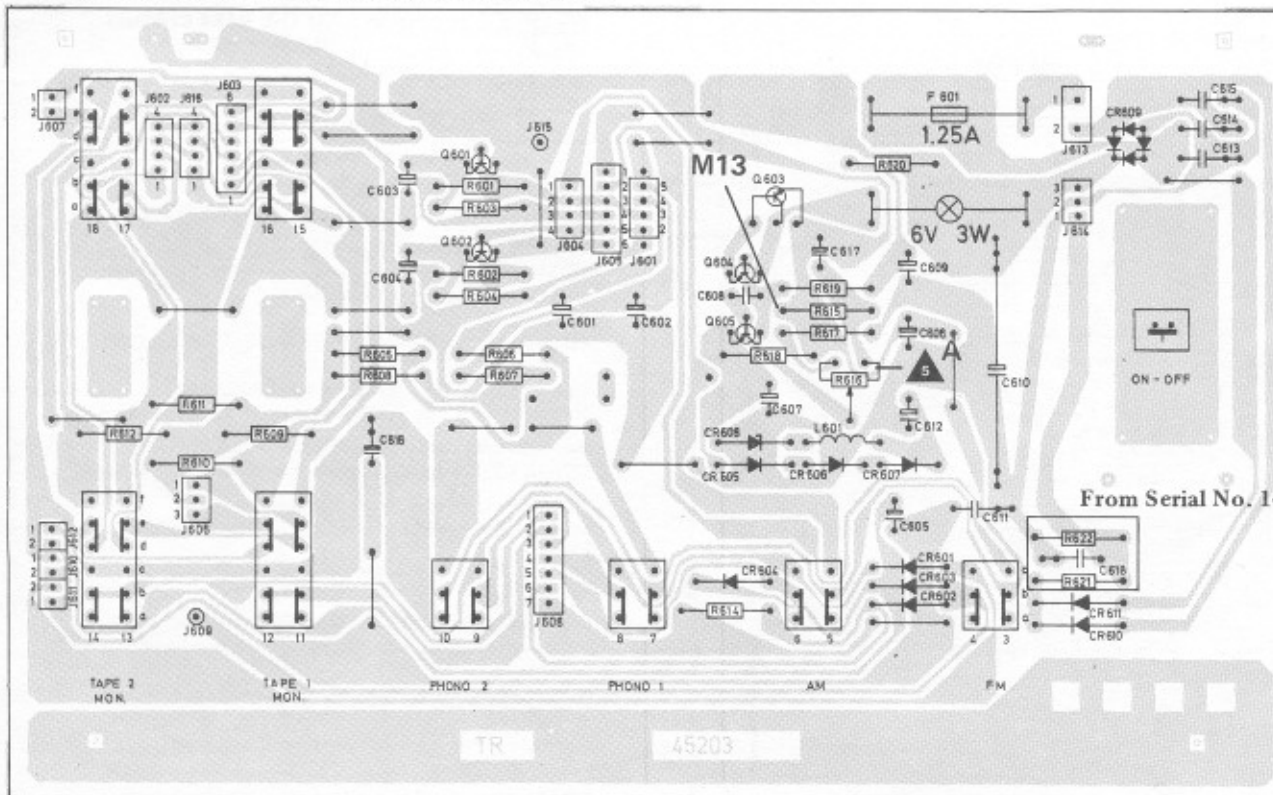

Seen from the solder side.

RIAA / INPUT AMP. BOARD

A5

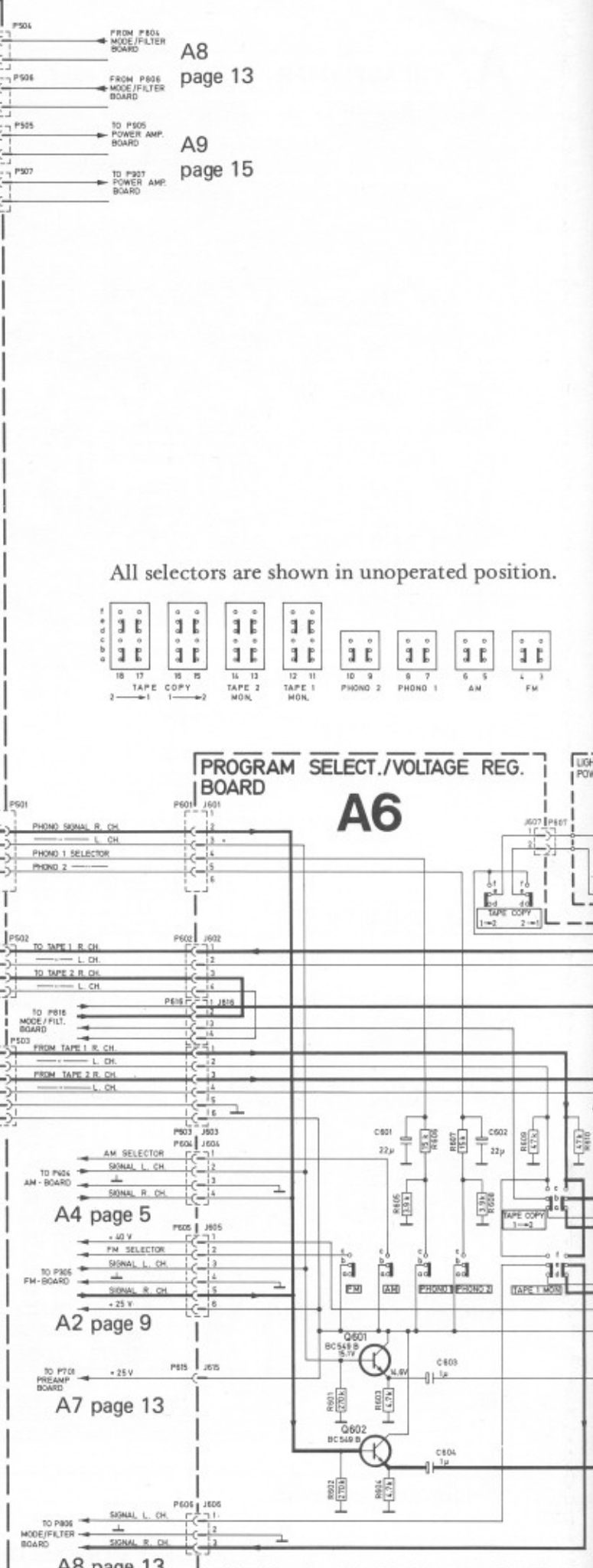
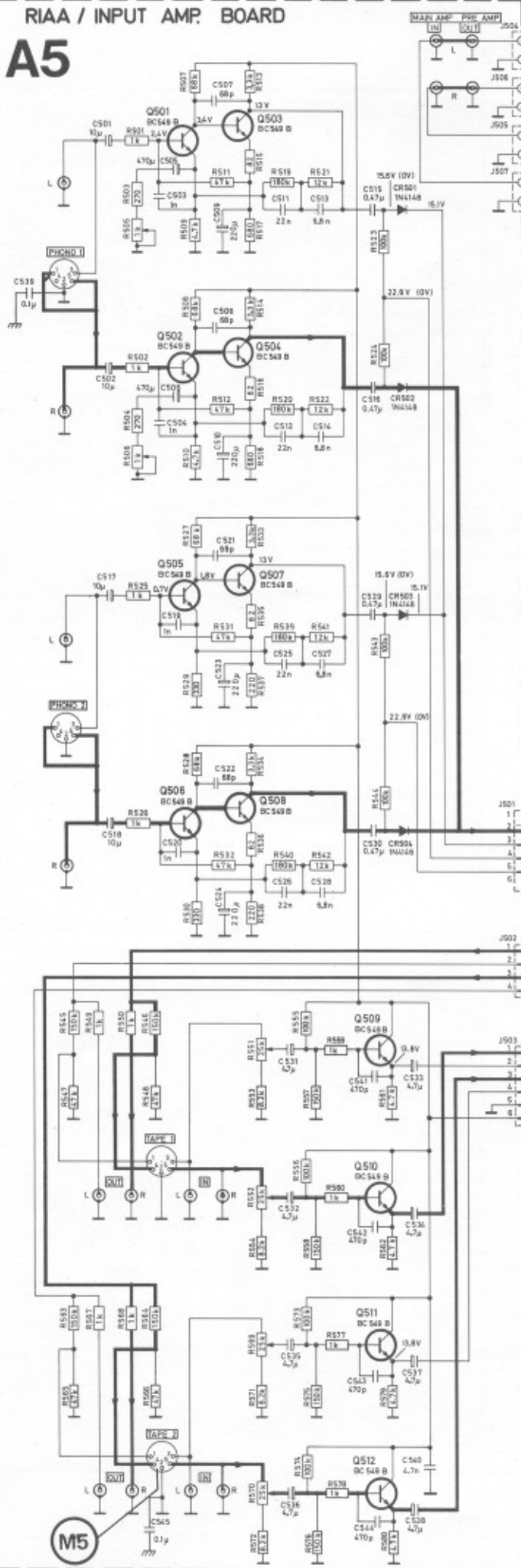

A8
page 13

A9
page 15

All selectors are shown in unoperated position.

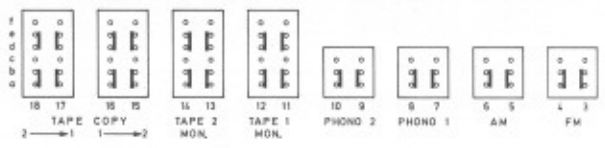

PROGRAM SELECT./VOLTAGE REG. BOARD

A6

A4 page 5

A2 page 9

A7 page 13

A8 page 13

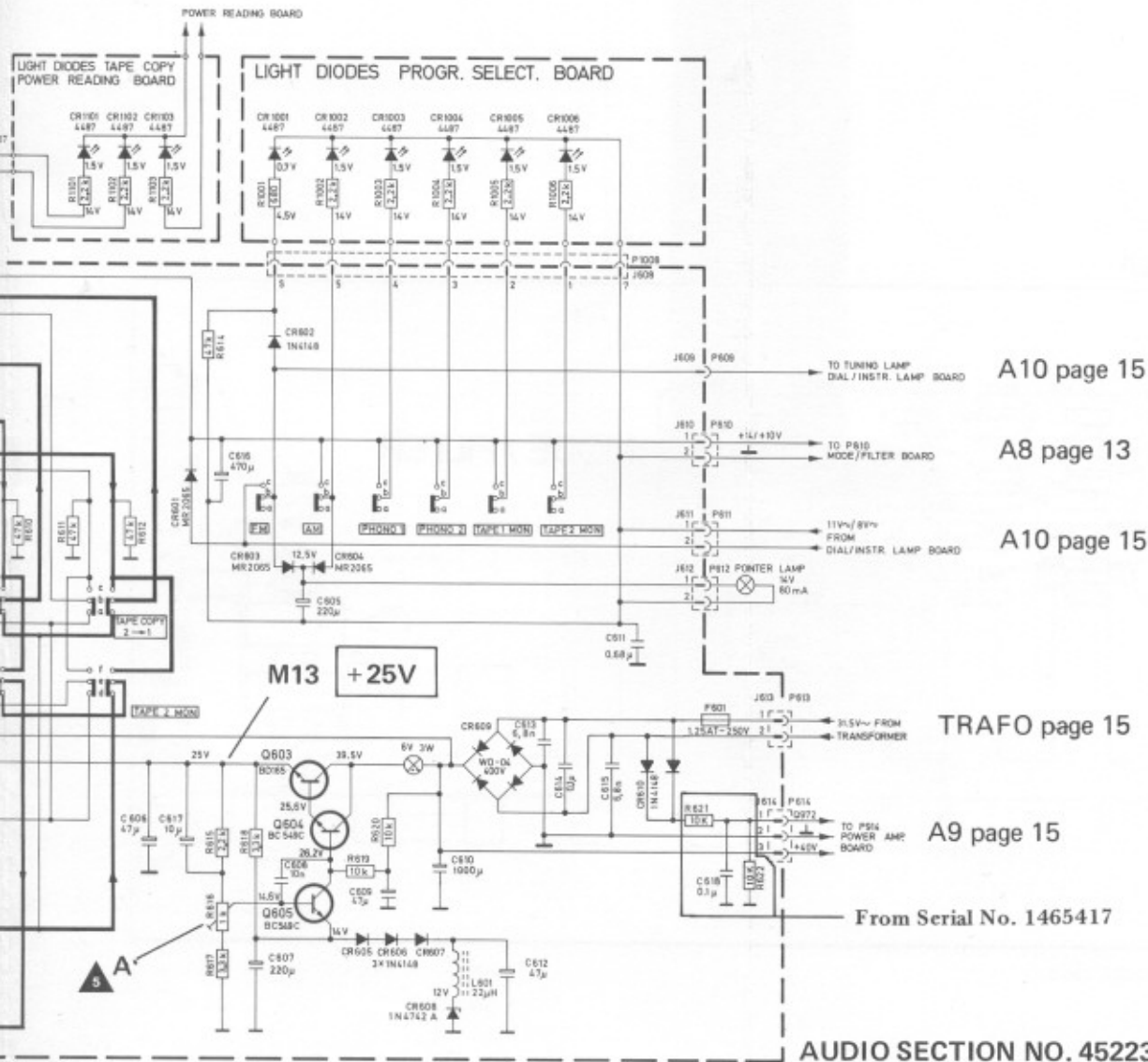
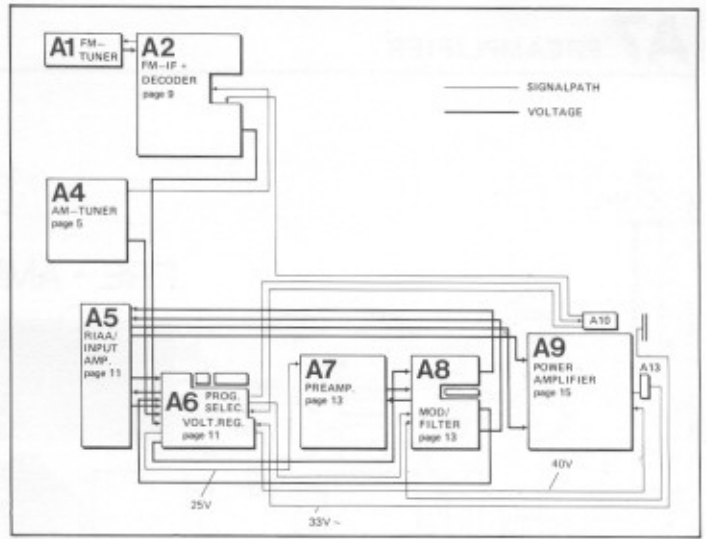
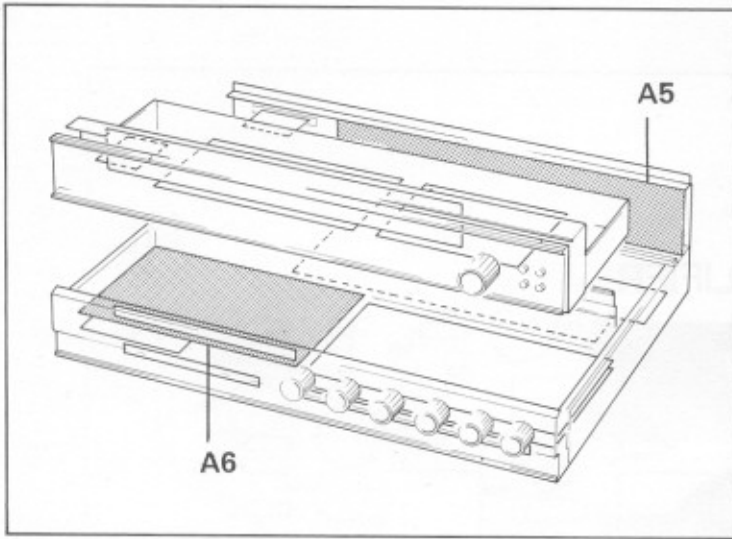

A7 PREAMPLIFIER

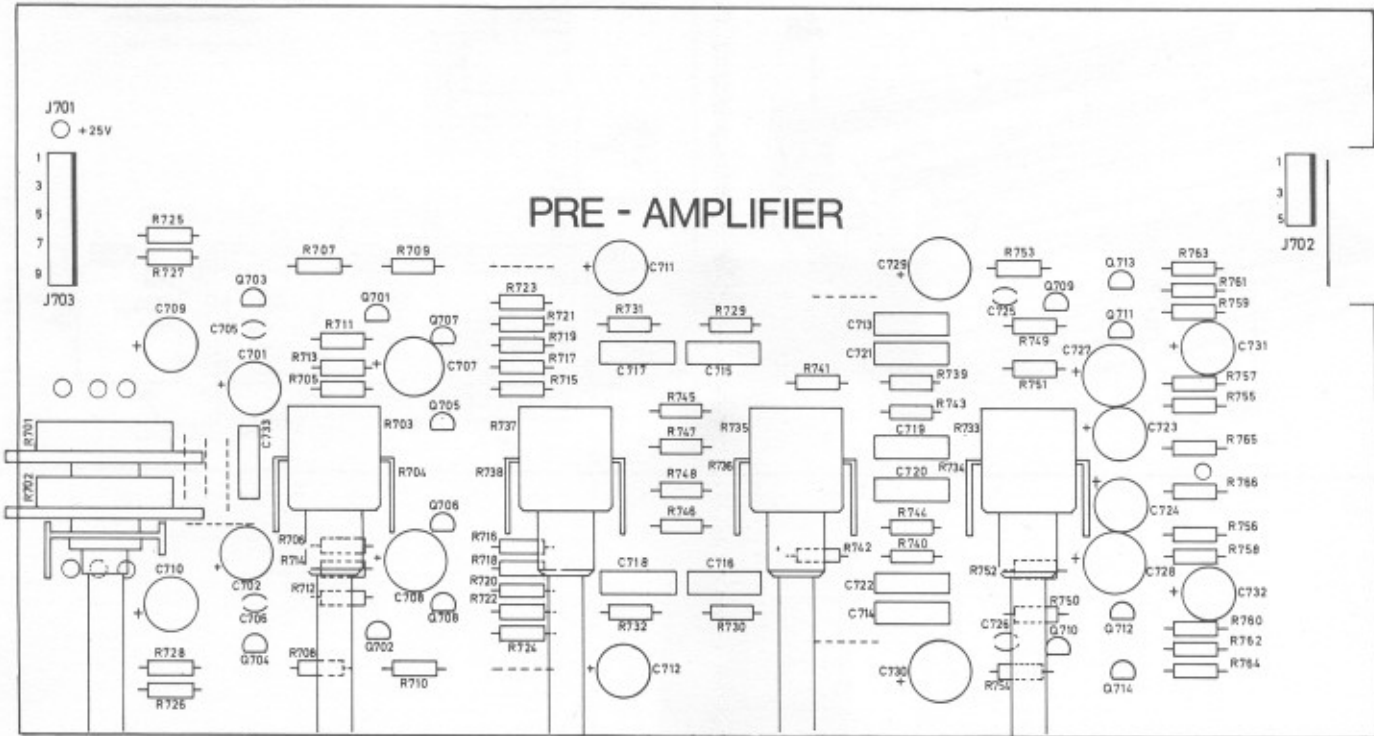

Seen from the component side.

A8 MODE/FILTER

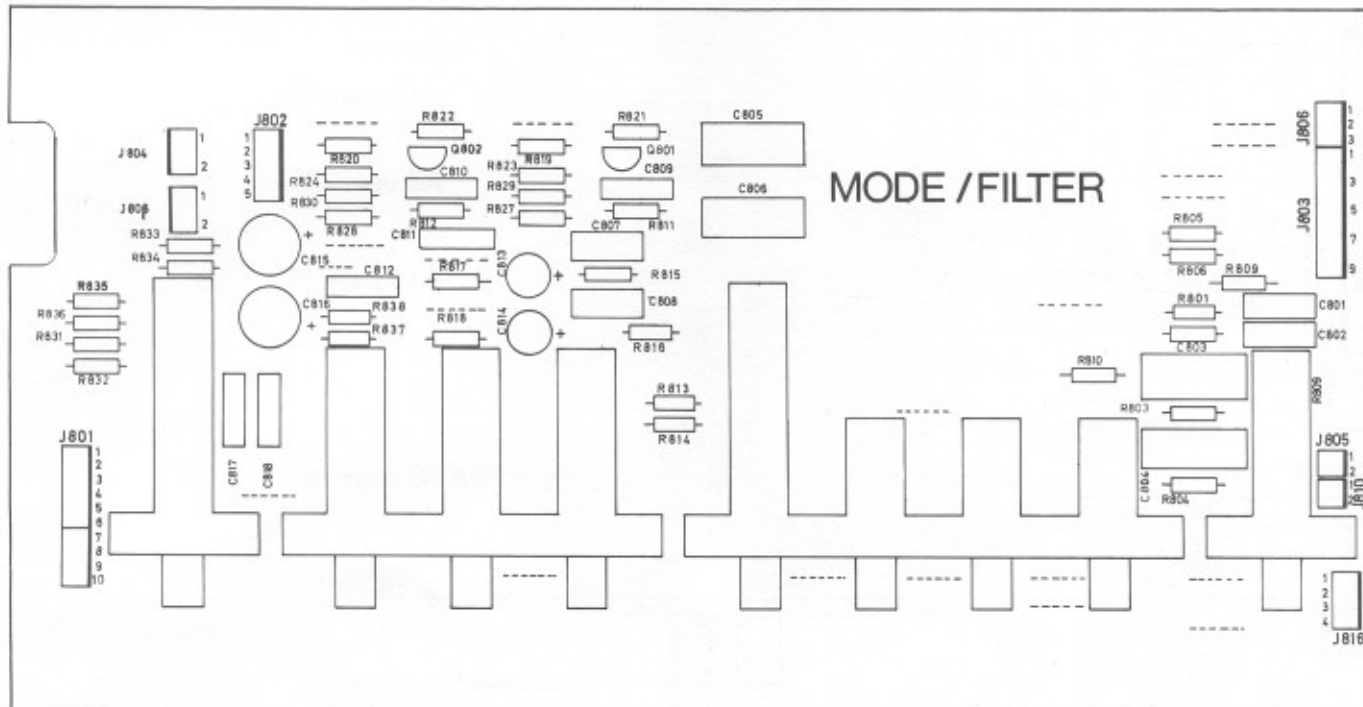

Seen from the component side.

A7 PREAMPLIFIER

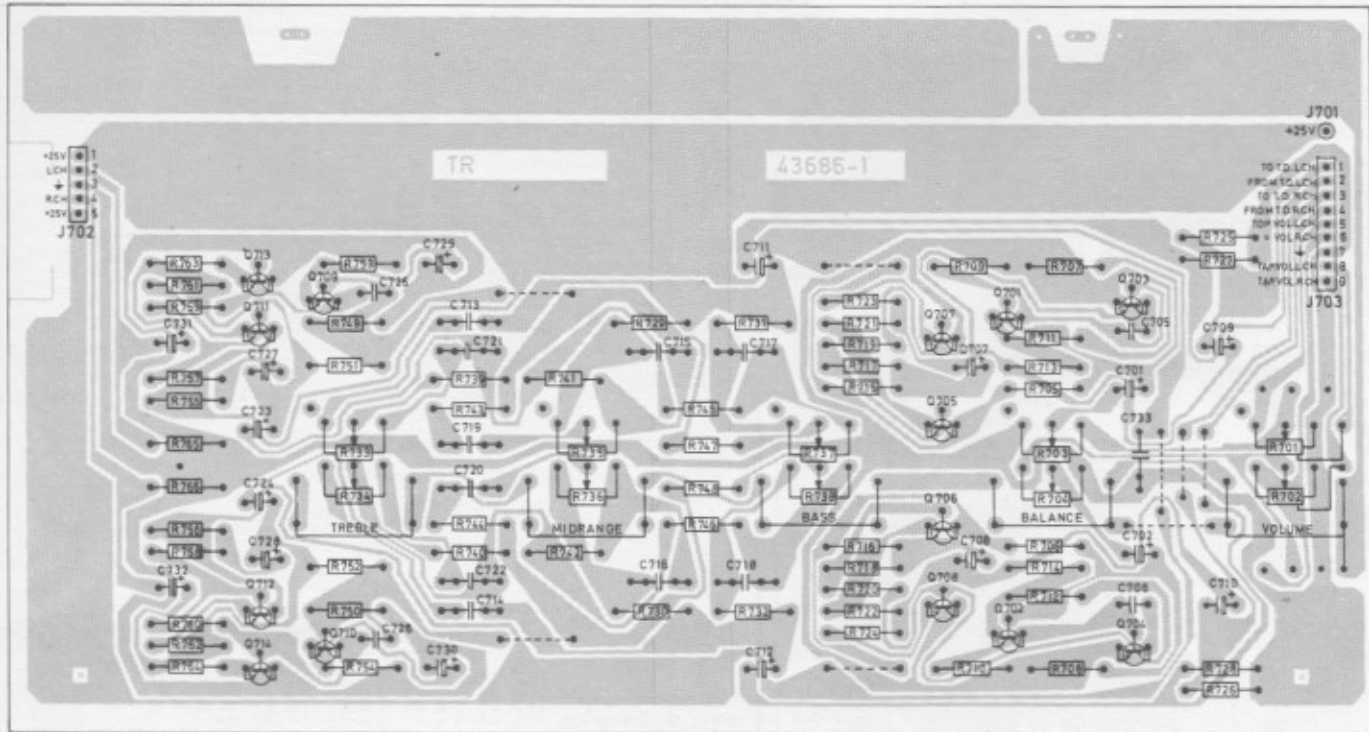

Seen from the solder side.



BC108
BC109

The transistors are seen from underneath.

A8 MODE/FILTER

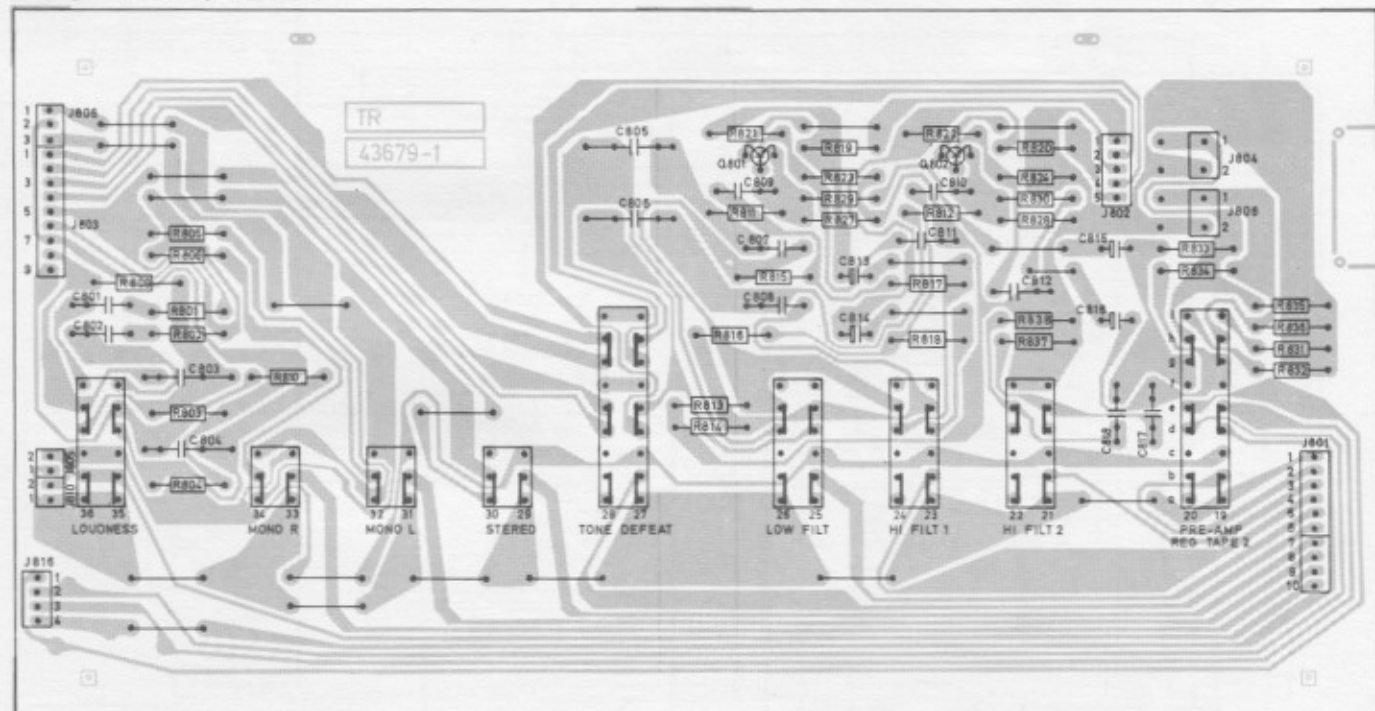

Seen from the solder side.

All selectors are shown in unoperated position.

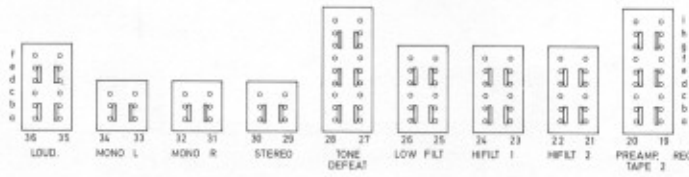

A6 page 11

FROM P015
PROG. SELECT
BOARD

A7 PREAMPLIFIER BOARD

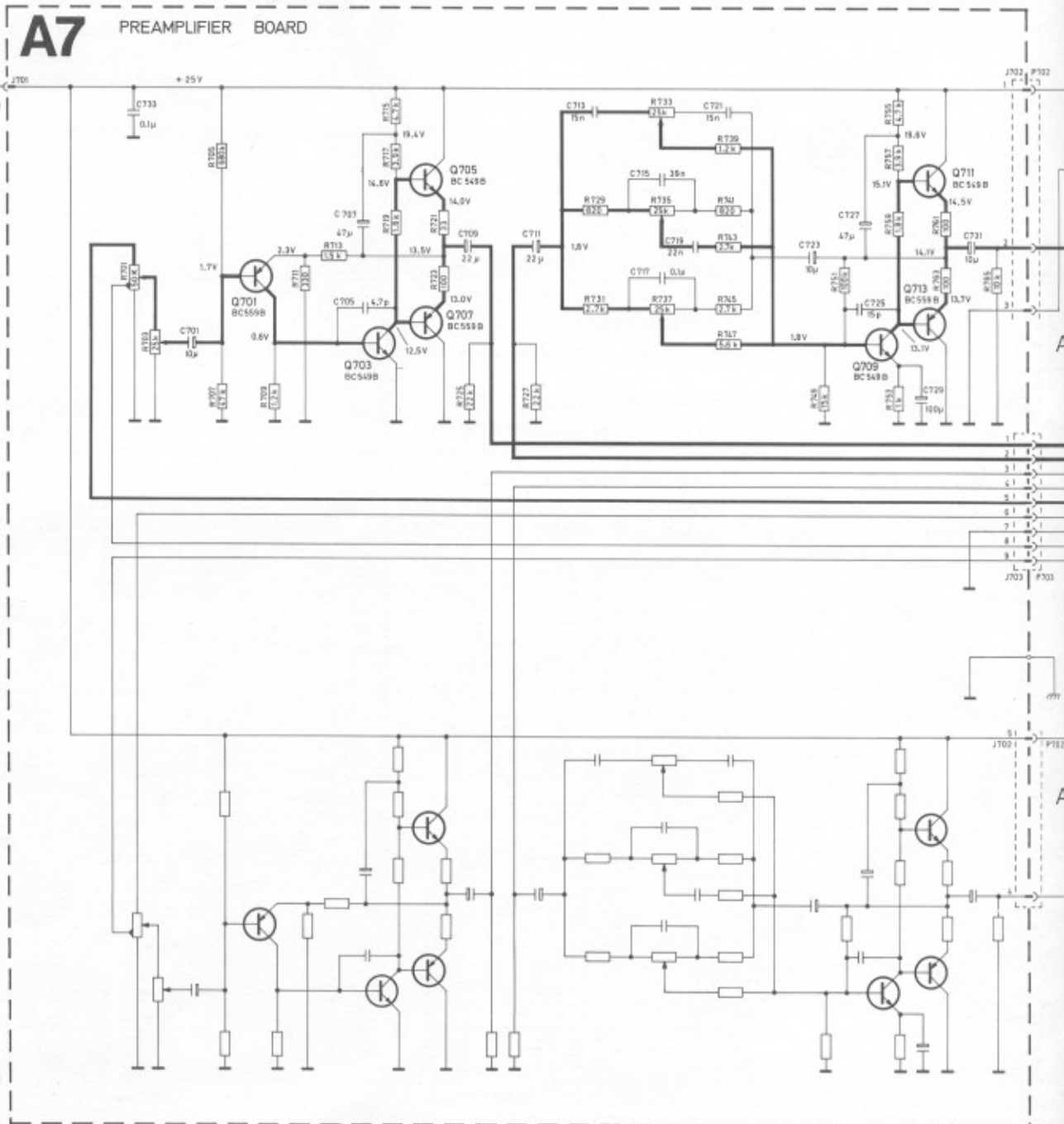

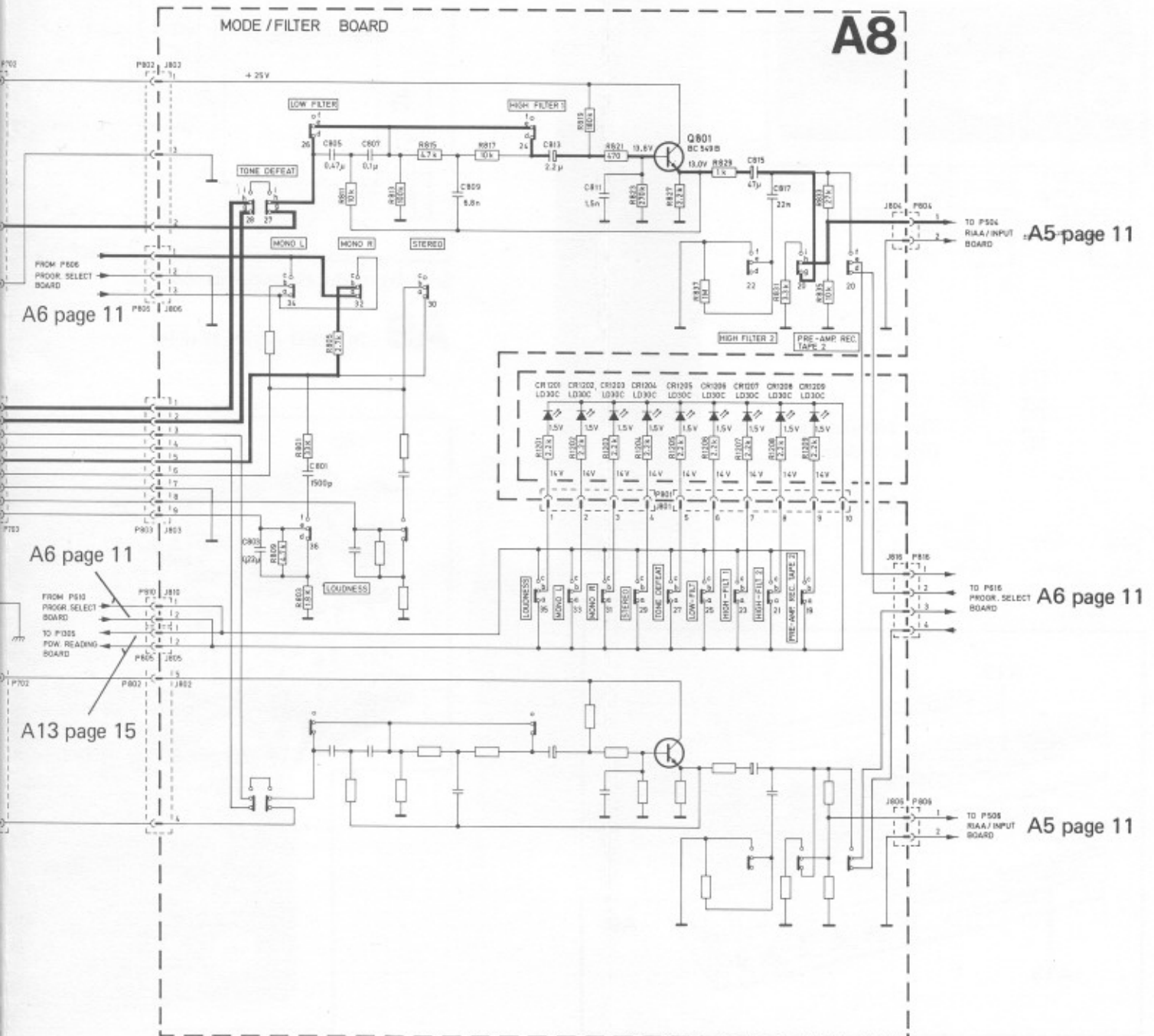
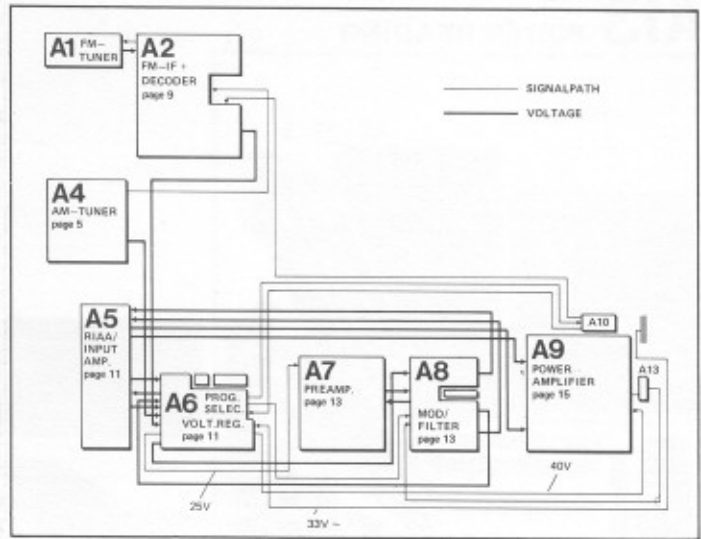
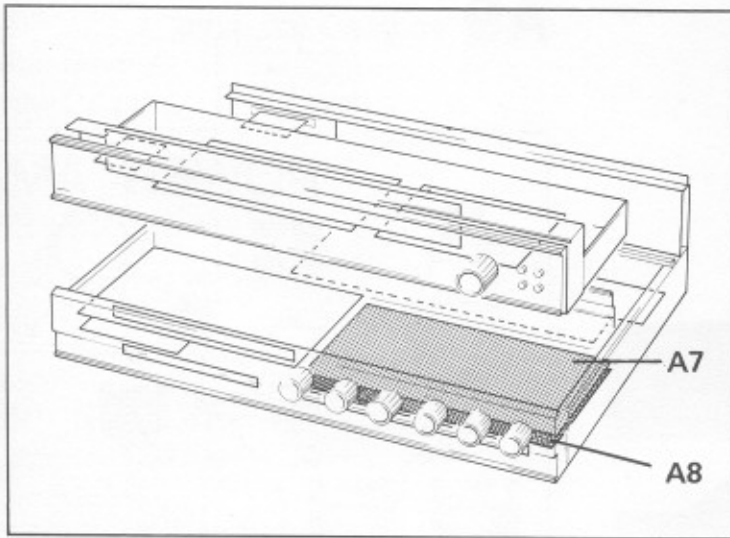

A13 POWER READING

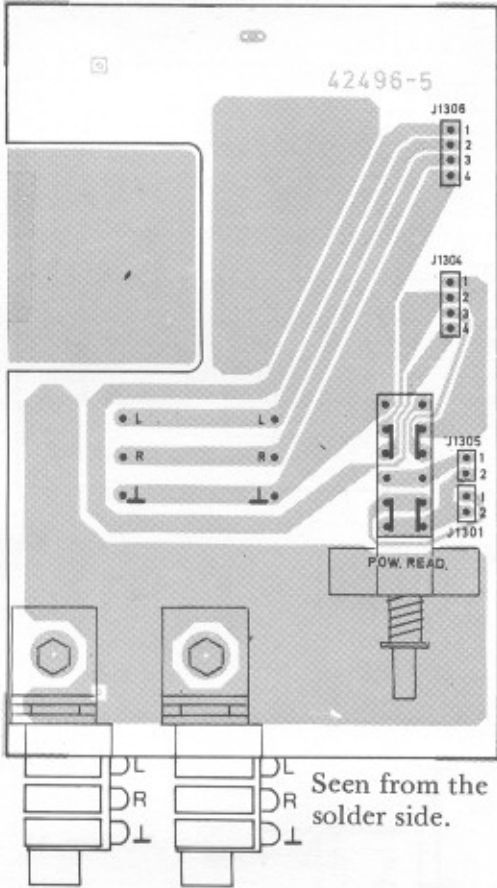

Seen from the solder side.



The transistors are seen from underneath.

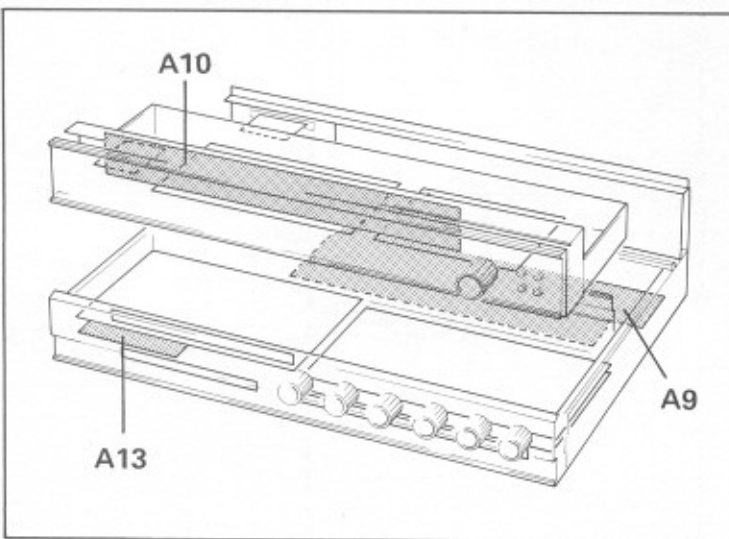

A9 POWER AMPLIFIER

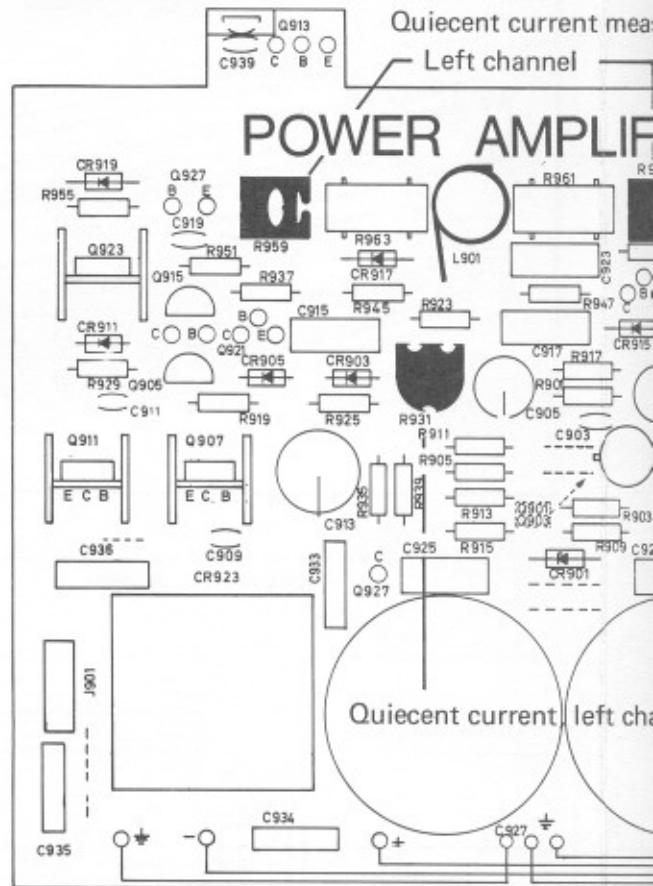

Seen from the component side

A9 POWER AMPLIFIER

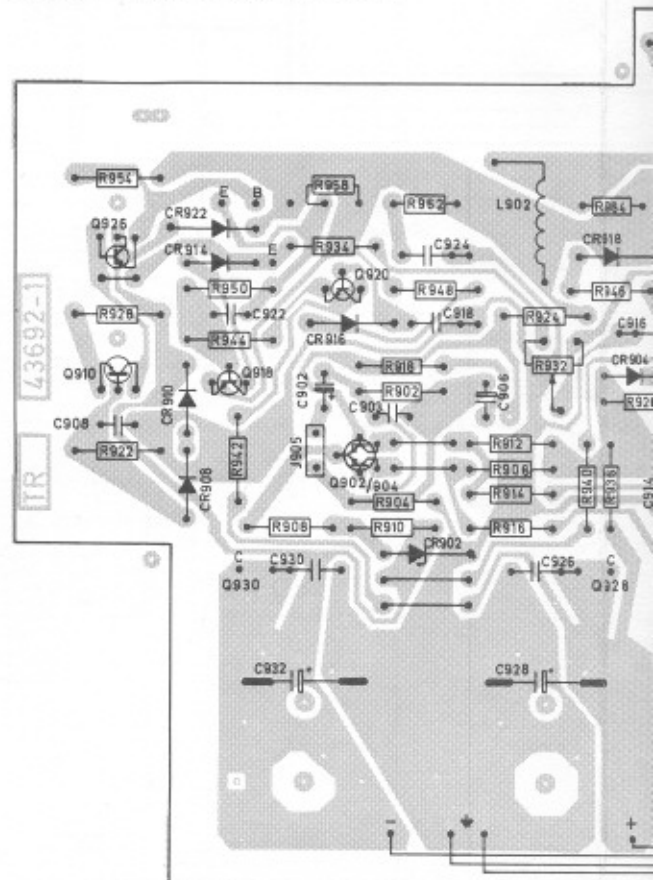

Seen from the solder side

measurement, 40 mV

Quiescent current measurement, 40 mV

AMPLIFIER

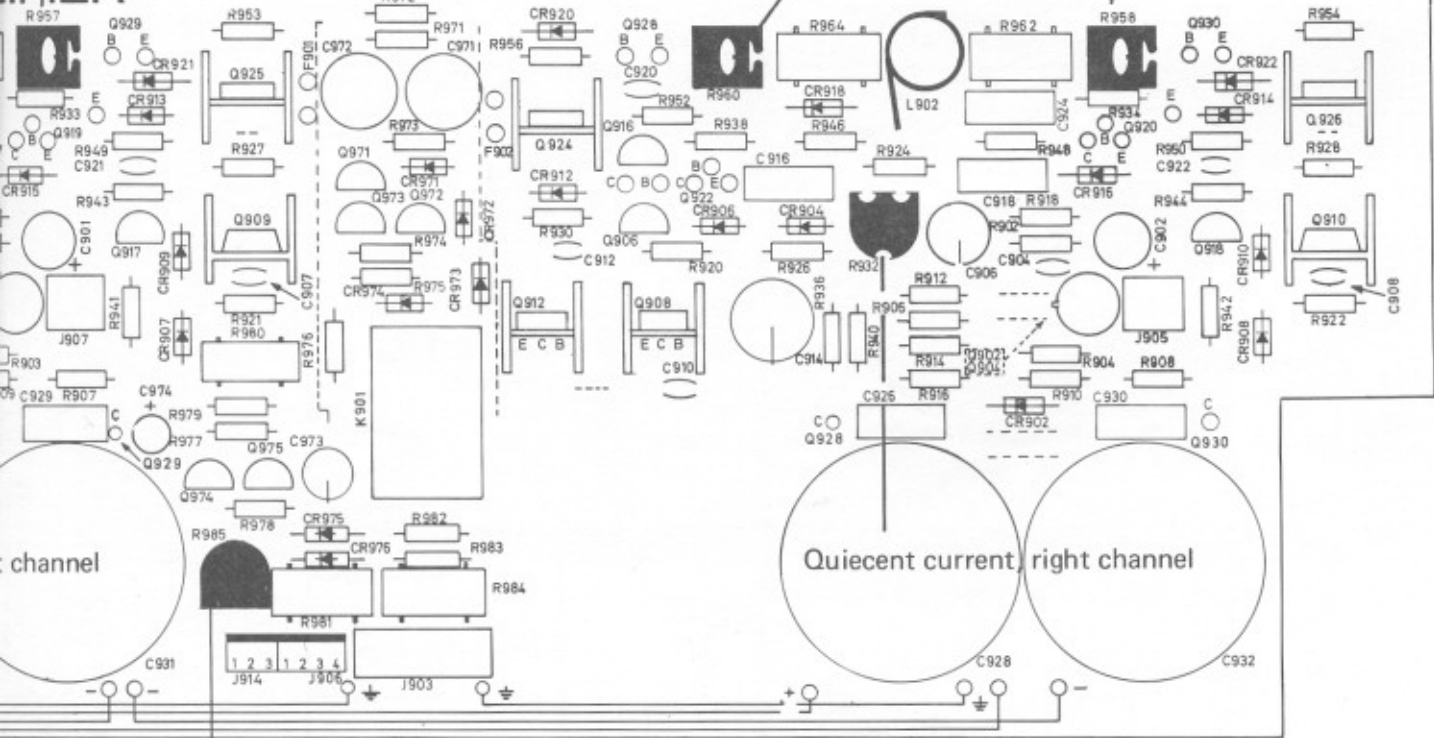

R985, POWER READING

* R985, see page 15.

" Pops " when switching the POWER OFF.

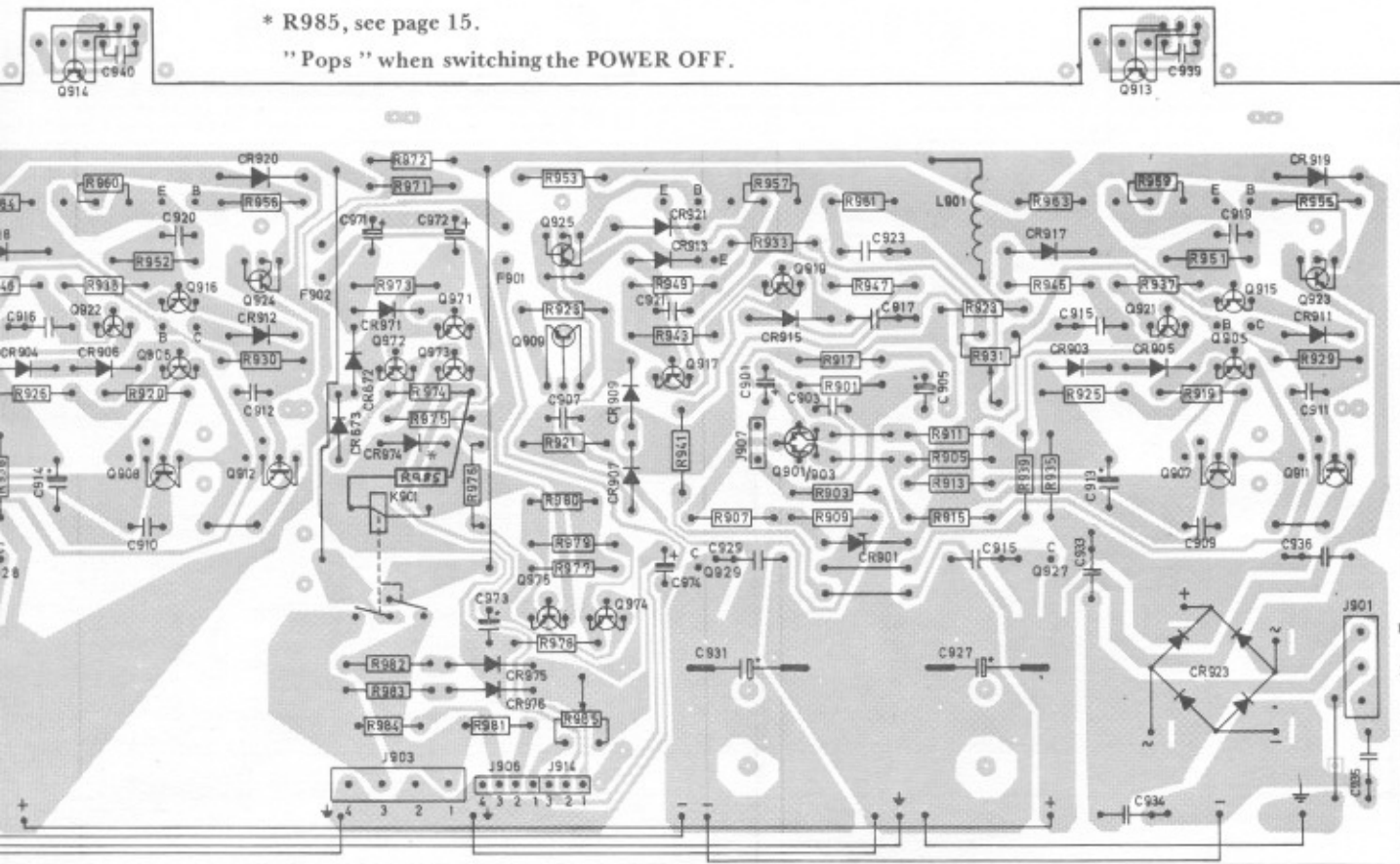

A2-page 9 FROM P302 FM-BOARD
 A6 page 11 TO P609 PROG. SELECT BOARD
 A6 page 11 TO P811 PROG. SELECT BOARD

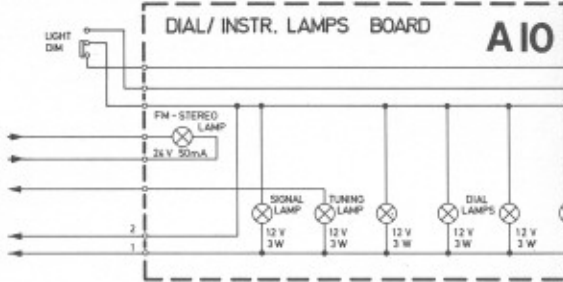

POWER-AMPLIFIER BOARD A9

A5 page 11

FROM P507 R5AA/INPUT BOARD
 SIGNAL L-CH.

A5 page 11

FROM P505 R5AA/INPUT BOARD
 SIGNAL R-CH.

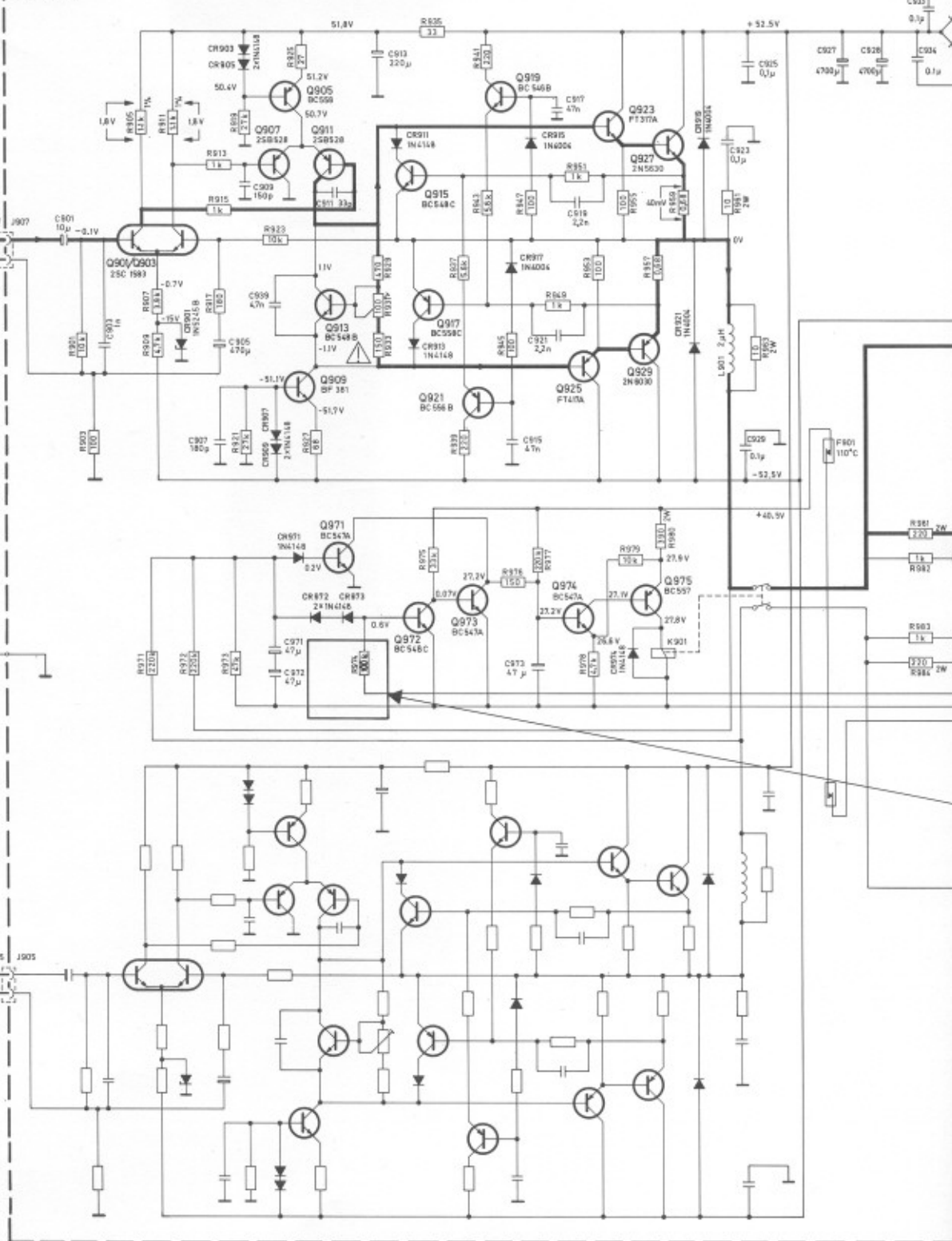

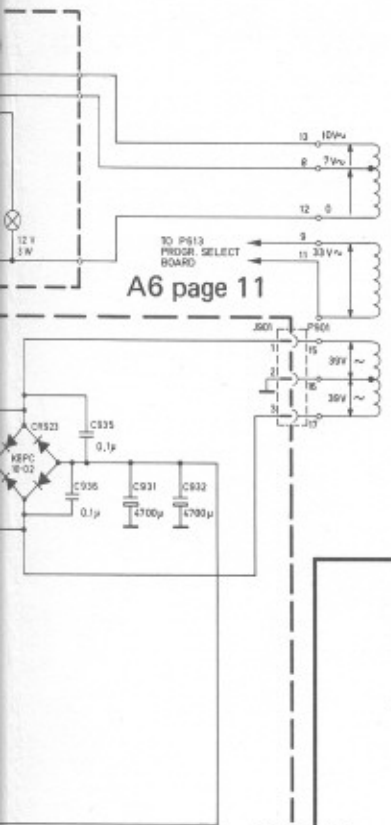

A6 page 11

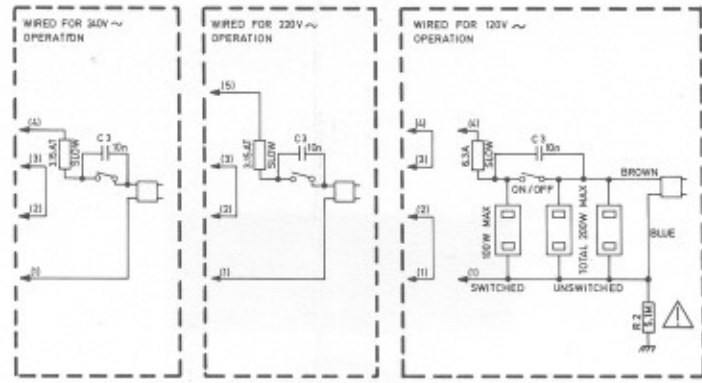

NOTE!
BE SURE TO REPLACE SAME TYPE OF COMPONENT!

POWER READING

Output power indicator (SIGNAL meter).

Depress the button POWER READING. Apply a signal to TAPE 1 input and measure the a.c. voltage across the speaker output.

TR2075 MK II

Adjust the input voltage or the VOLUME until the output voltage is 25 volts.

Adjust R985 for the same reading on the SIGNAL meter.

TR2080

Adjust the input voltage or the VOLUME until the output voltage is 20 volts.

Adjust R985 to 50 (W) on the SIGNAL meter.

AF - ADJUSTMENTS.

Quiescent current.

The most convenient place to connect the voltmeter is between the top of emitter resistors R957/R959 (left channel) and R958/R960 (right channel) on the component side of the board.

After 10 minutes warm-up (with the volume control in minimum position), the voltage should be 40 mV. If necessary, adjust with R931 (left channel) and R932 (right channel).

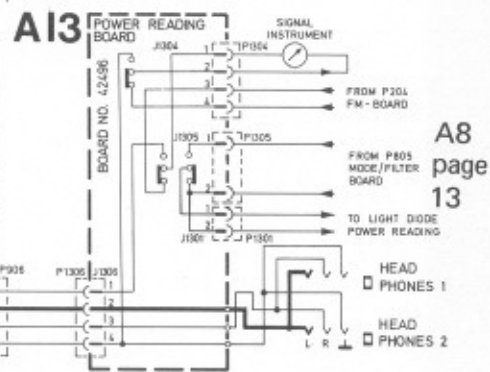
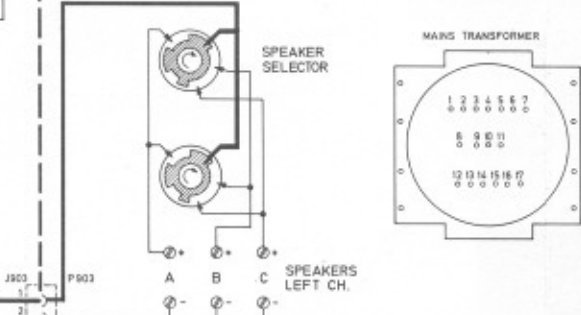

A8 page 13

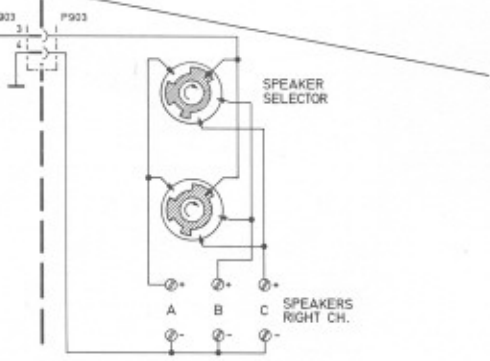
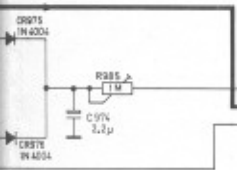

AUDIO SECTION 3 NO. 45225

" Pops " when switching the POWER OFF, to Serial No. 1465417.

- R974, 470K, replace with 100K.
- * R985, 470K, remove.
- ** R621, 10K, new.
- ** R622, 10K, new.
- ** C618, 0.1µF, new.

- * R985 are mounted on the solder side on board A6, see page 10.
- In some receivers the R985 are mounted on the solder side of board A9, see page 14.
- ** Solder R621, R622 and C618 on to the solder side on board A6, see page 10.
- Cut the foil between the legs on R621.