

SCHEMATIC DIAGRAMS

回路図

CONTENTS 目次

MAIN PCB (1/4).....	Page 1/13
MAIN PCB (2/4), INPUT VR PCB	Page 2/13
MAIN PCB (3/4).....	Page 3/13
MAIN PCB (4/4).....	Page 4/13
FRONT PCB, KEY PCB, SW PCB, P-CON PCB.....	Page 5/13
IN/OUT PCB.....	Page 6/13
PHONE PCB, MONITOR PCB.....	Page 7/13
CONVERTER PCB (1/5)	Page 8/13
CONVERTER PCB (2/5)	Page 9/13
CONVERTER PCB (3/5)	Page 10/13
CONVERTER PCB (4/5)	Page 11/13
CONVERTER PCB (5/5)	Page 12/13
POWER SUPPLY SECTION.....	Page 13/13

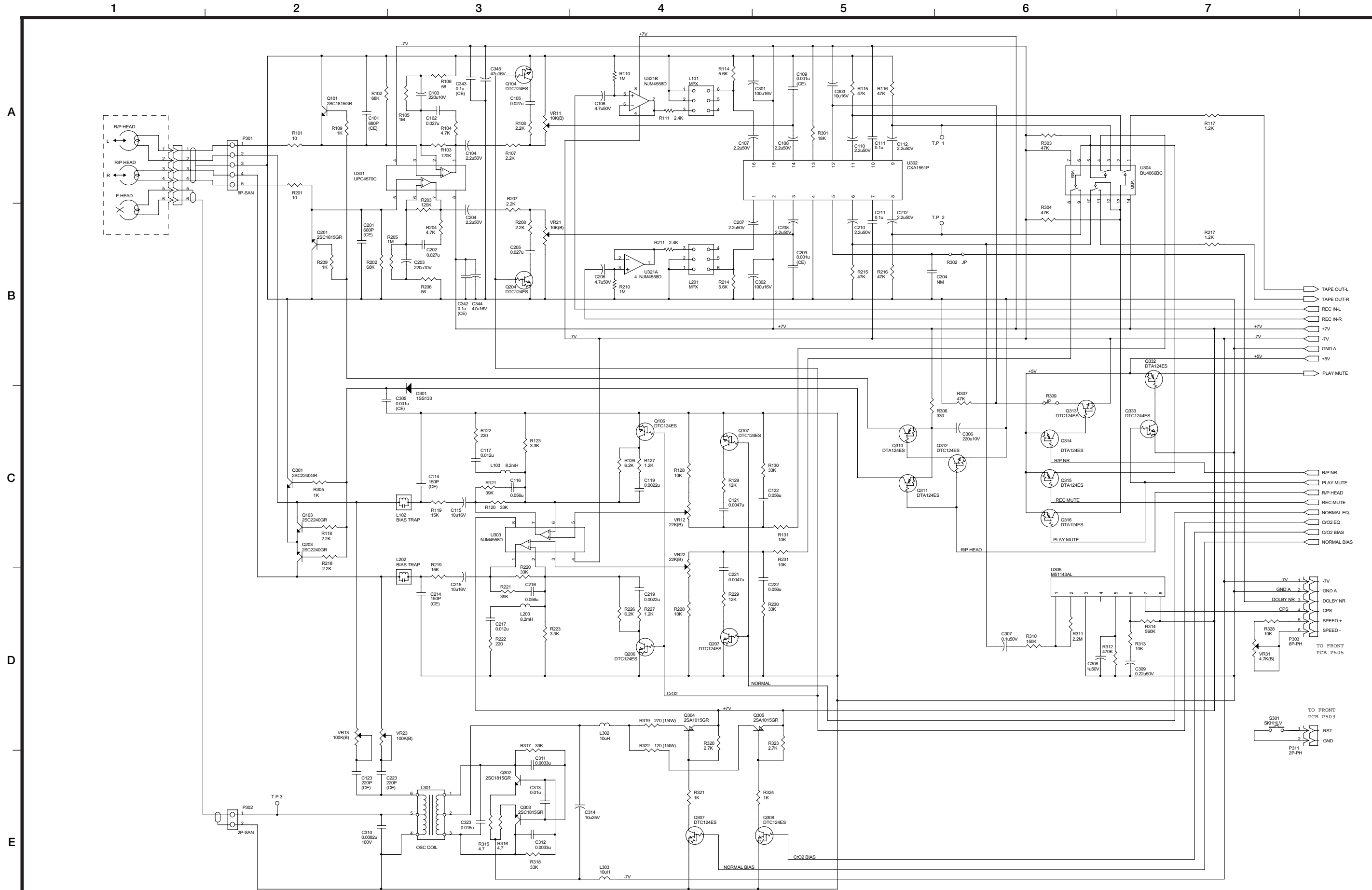

CD Recorder/Cassette Deck **CC-222**

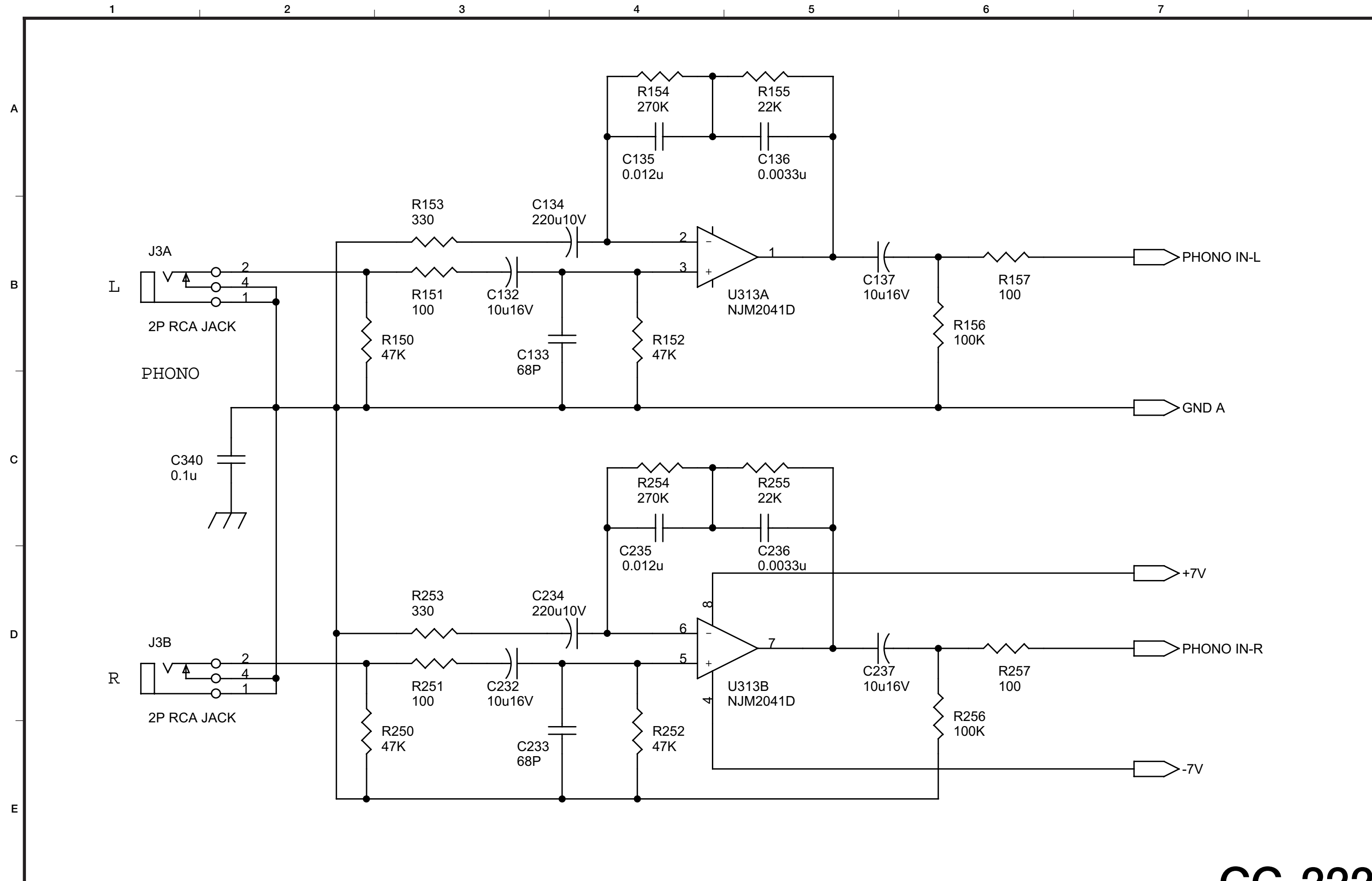

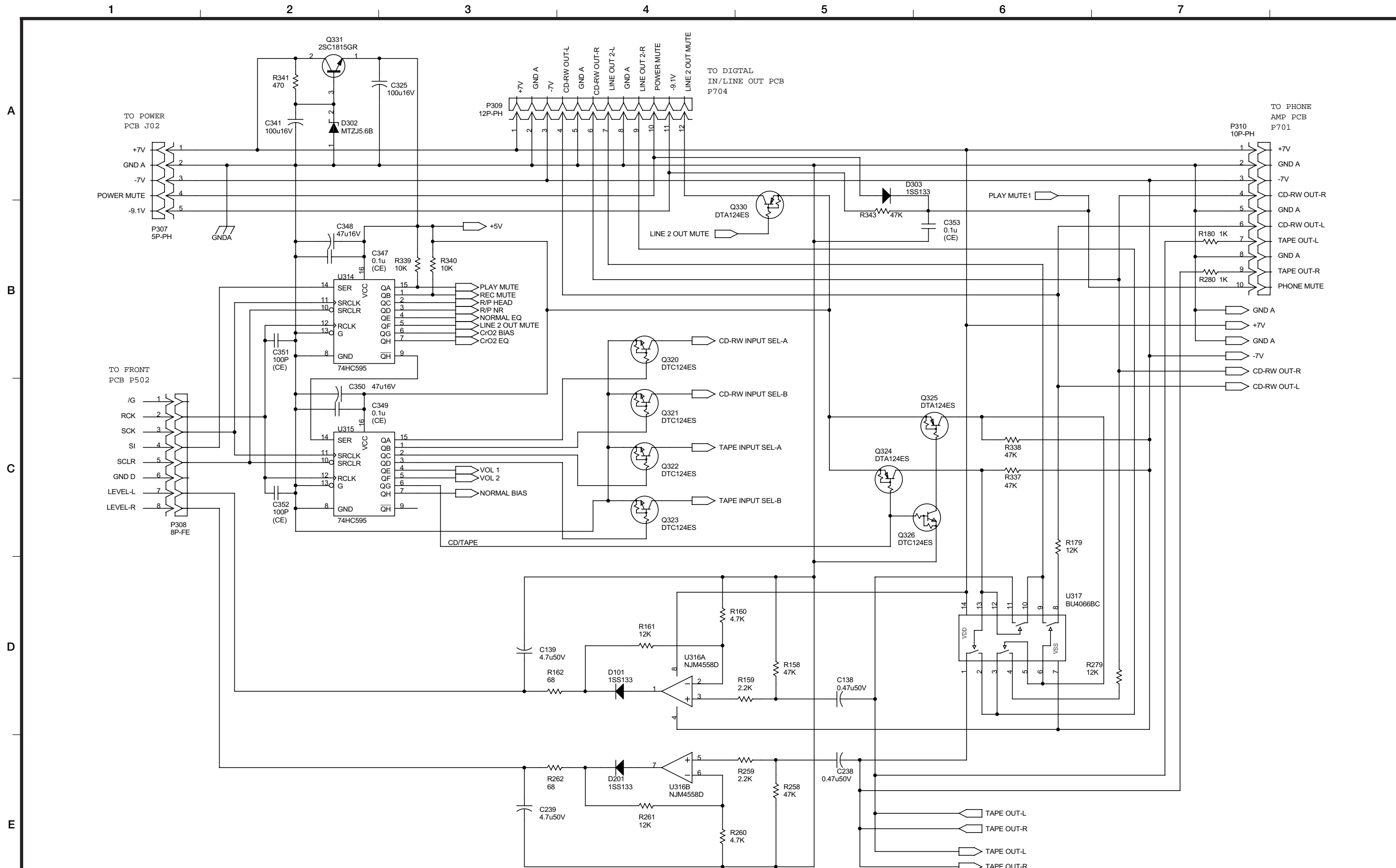

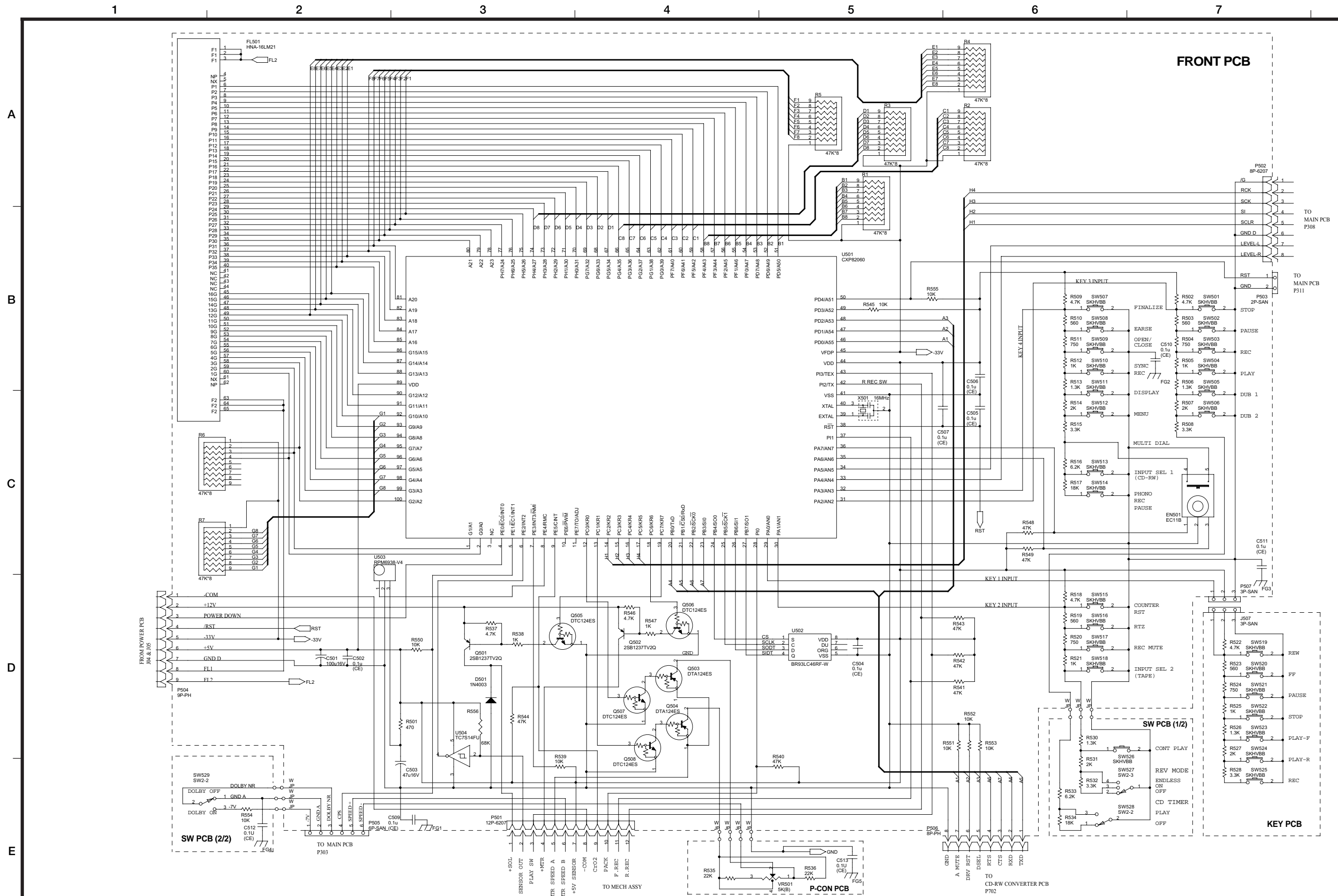

CD Recorder/Cassette Deck **CC-222**

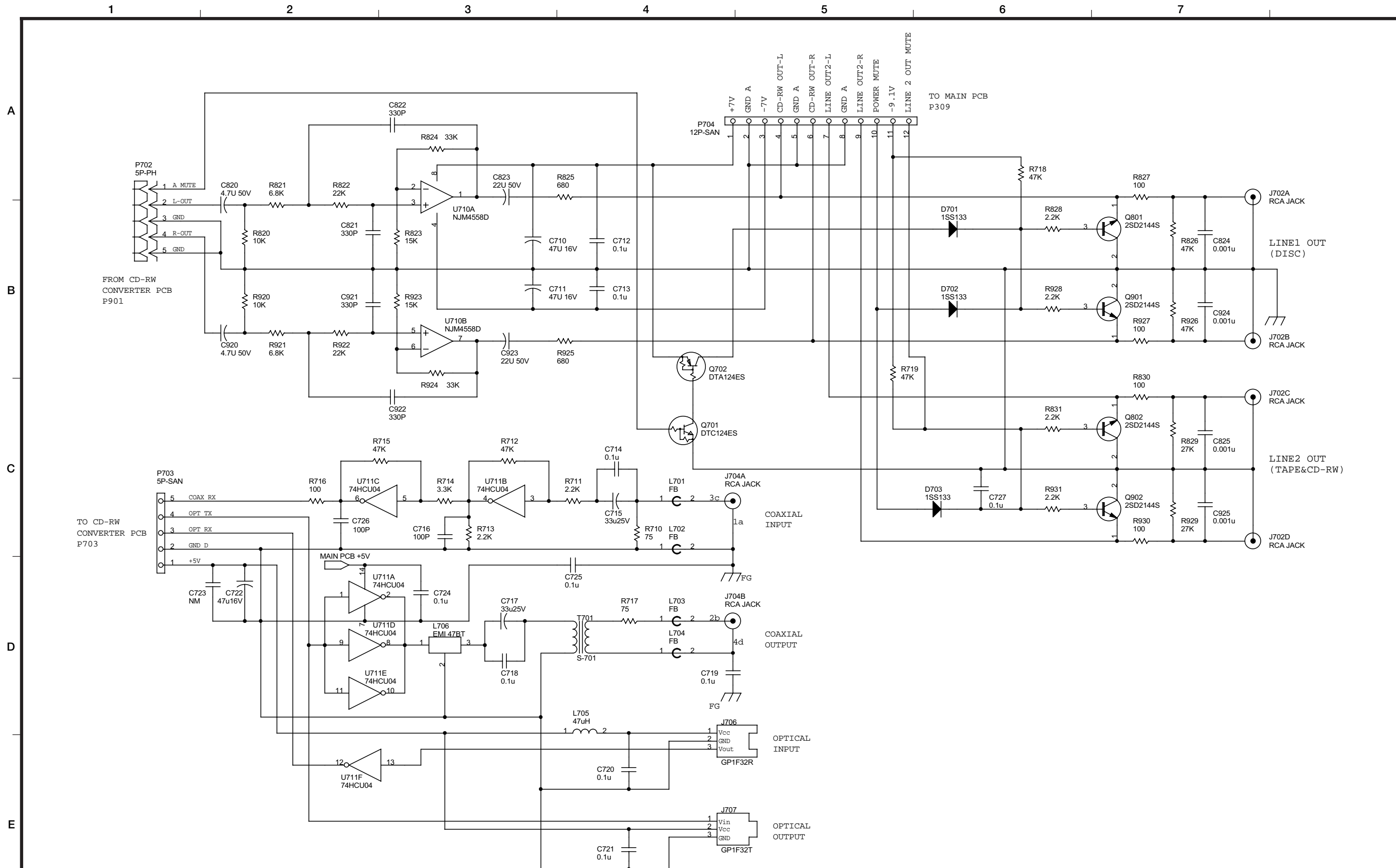

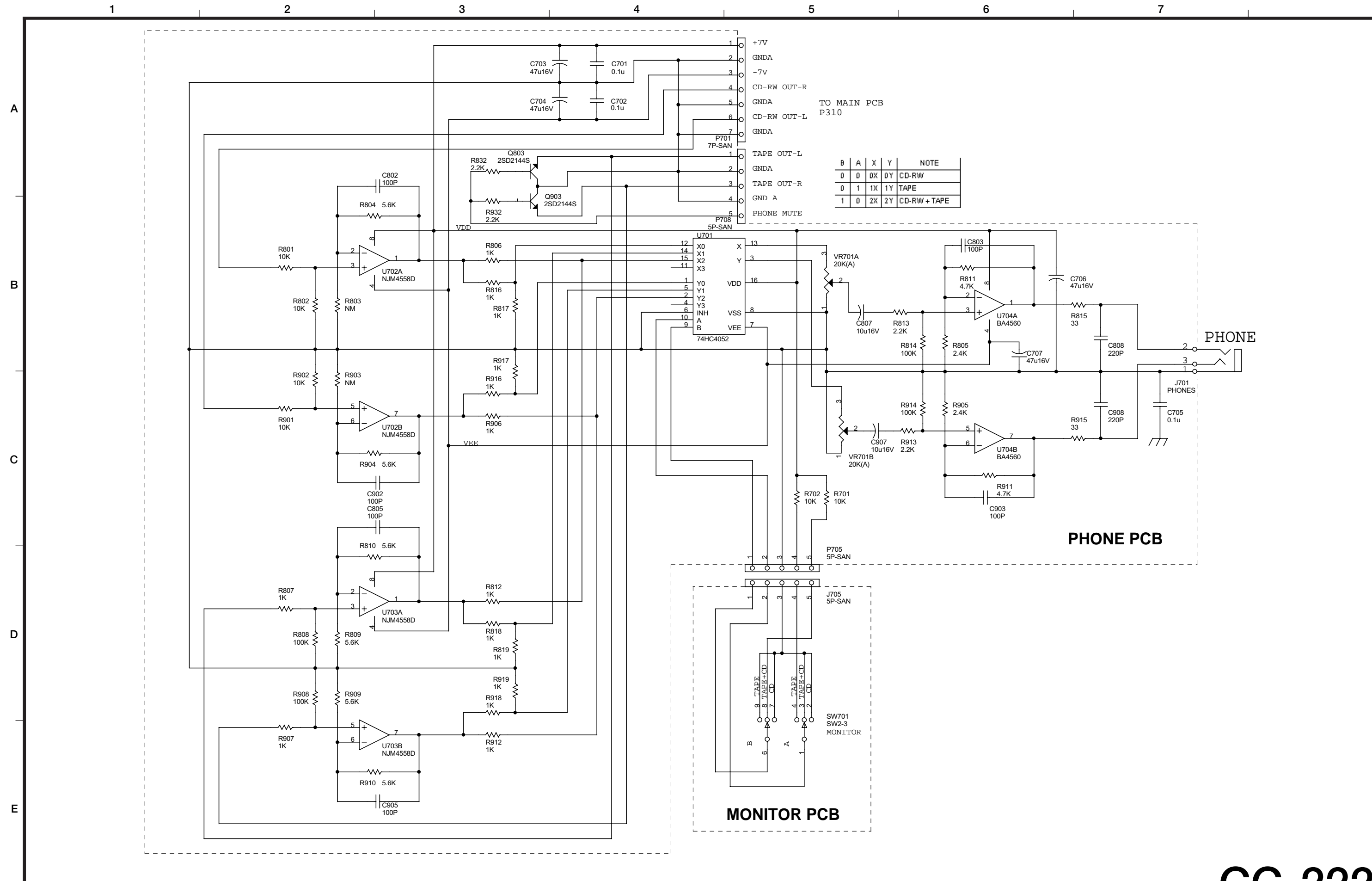

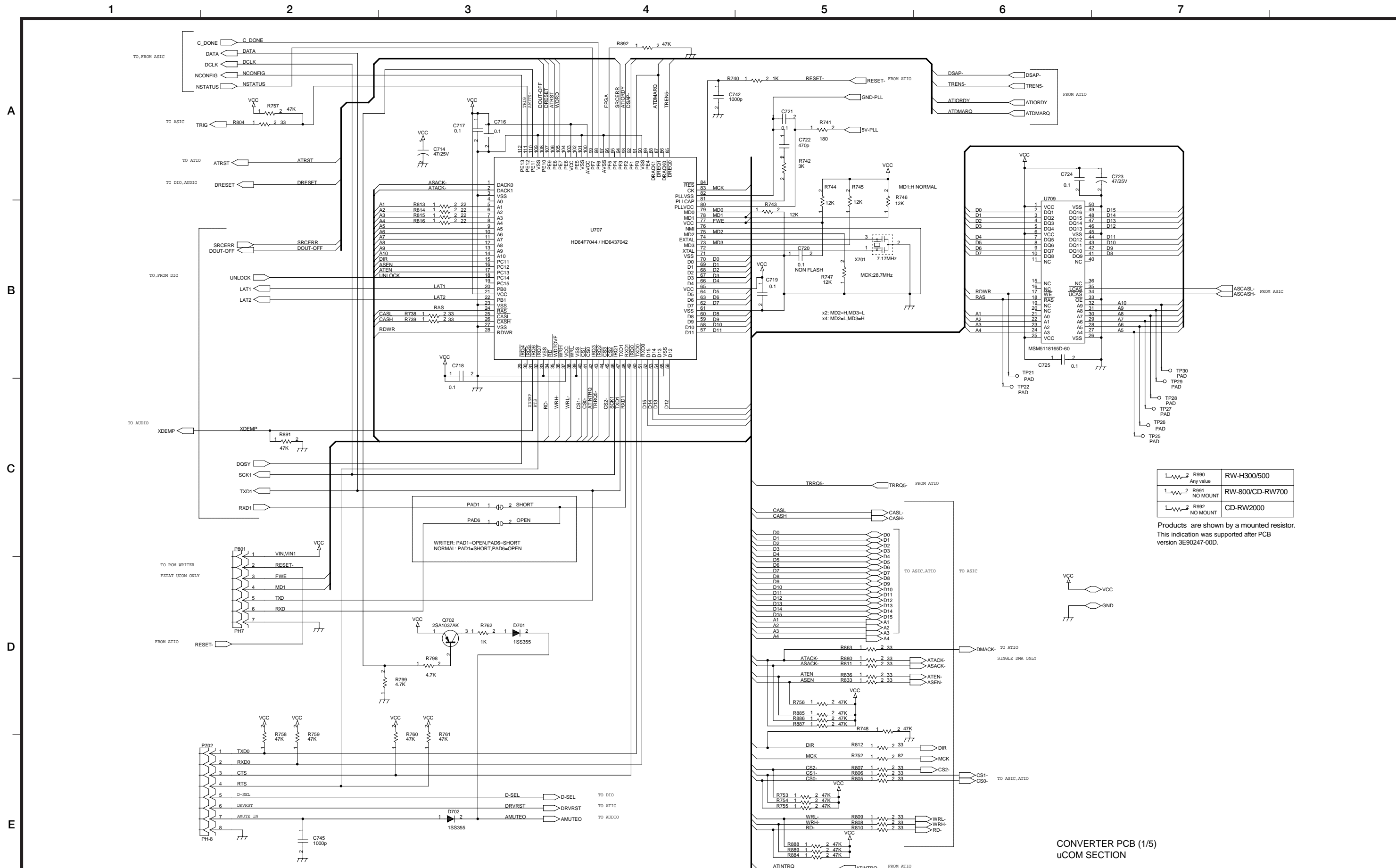

1-2 R990 Any value	RW-H300/500
1-2 R991 NO MOUNT	RW-800/CD-RW700
1-2 R992 NO MOUNT	CD-RW2000

Products are shown by a mounted resistor.
This indication was supported after PCB
version 3E90247-00D.

CONVERTER PCB (1/5)
uCOM SECTION

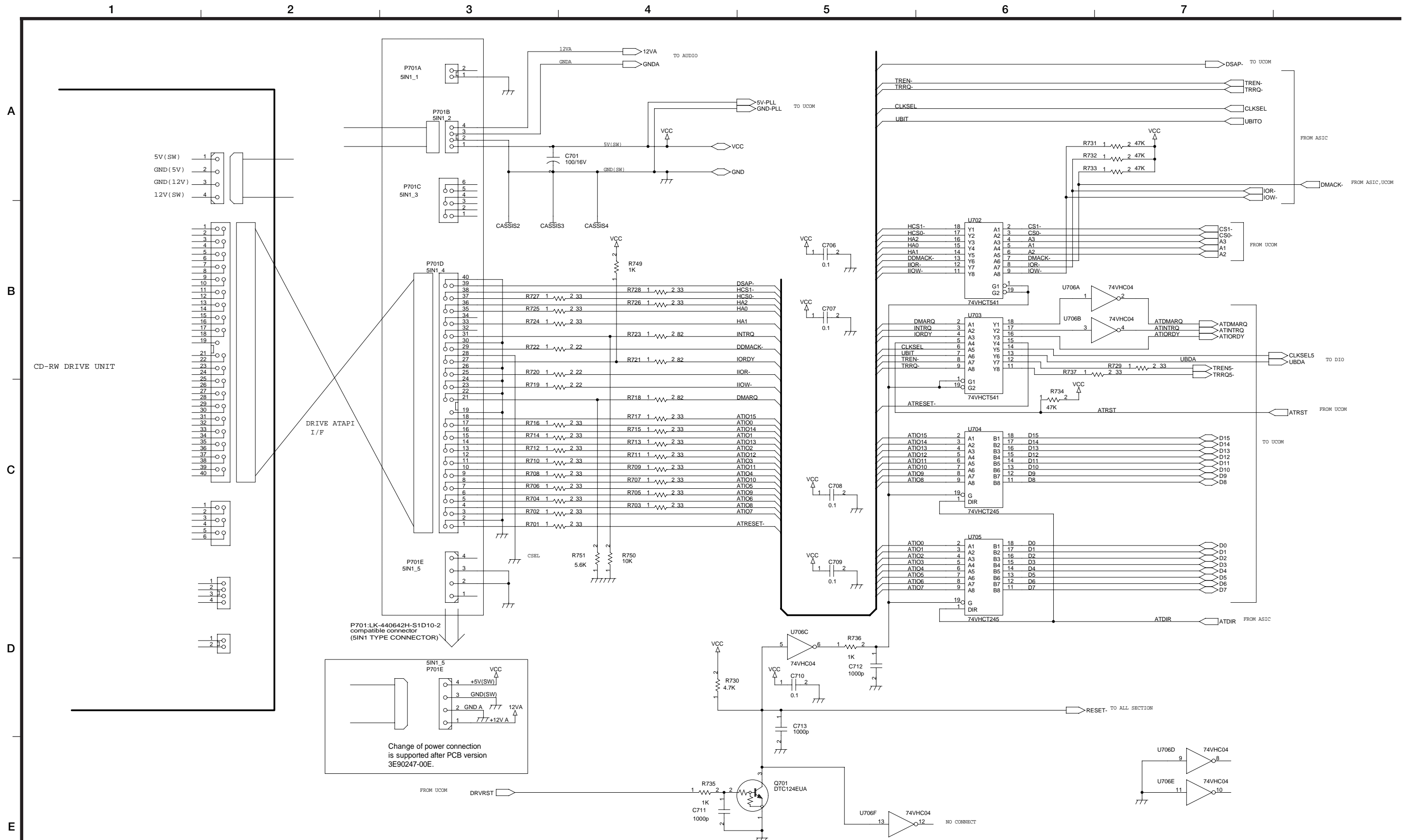

P701:LK-440642H-S1D10-2 compatible connector (SIN1 TYPE CONNECTOR)

Change of power connection is supported after PCB version 3E90247-00E.

CONVERTER PCB (3/5)
ATIO SECTION

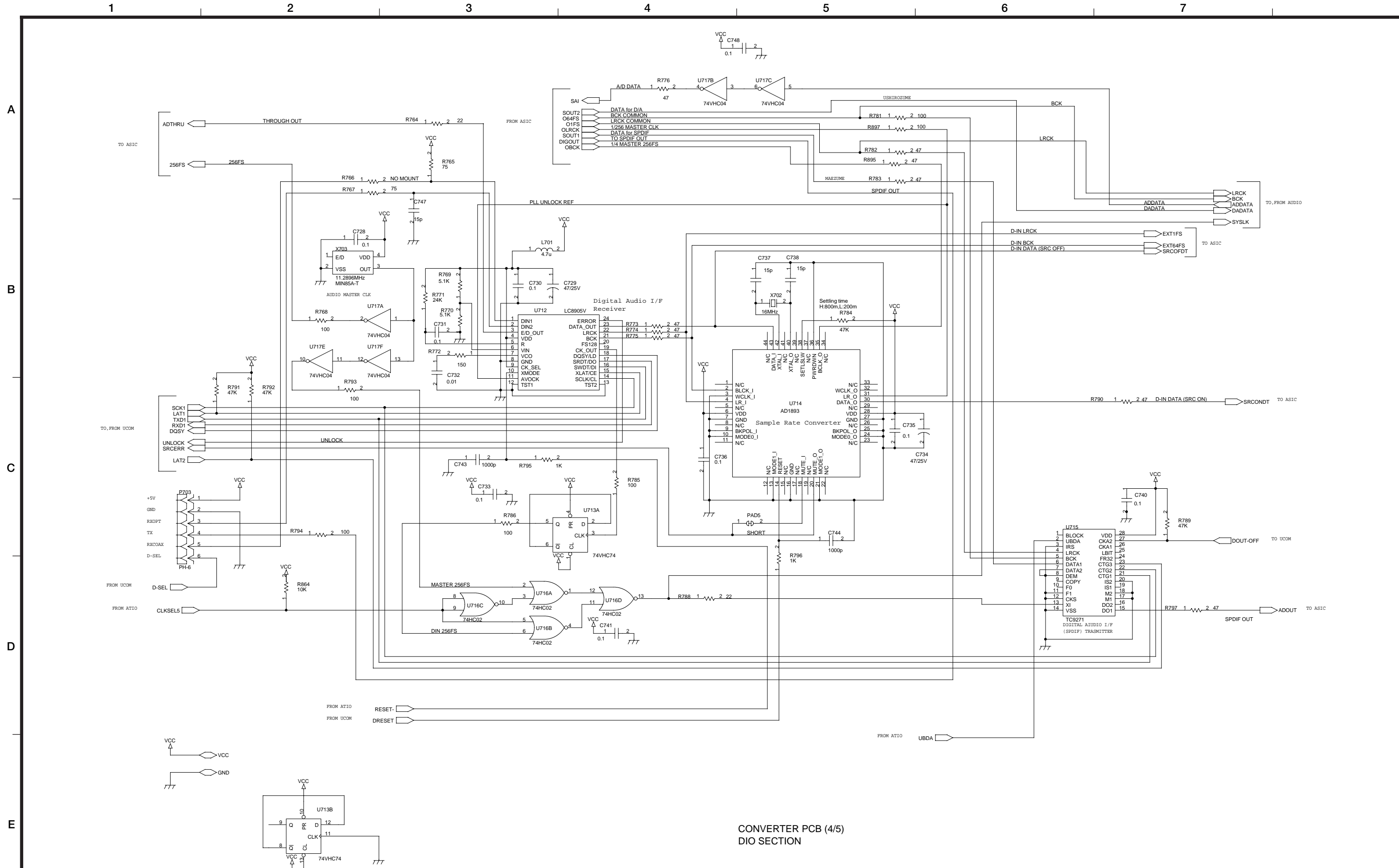

CONVERTER PCB (4/5)
DIO SECTION

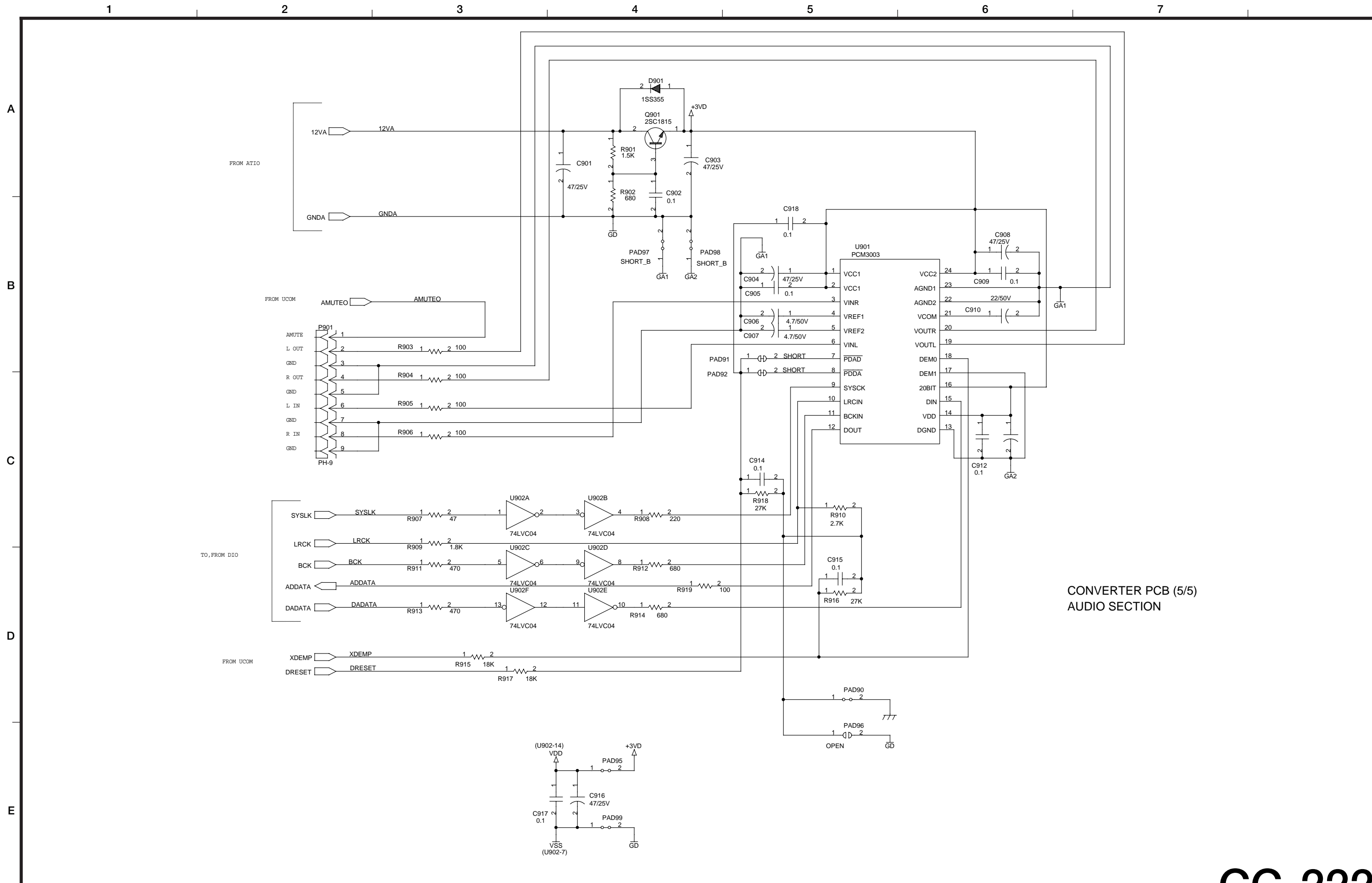

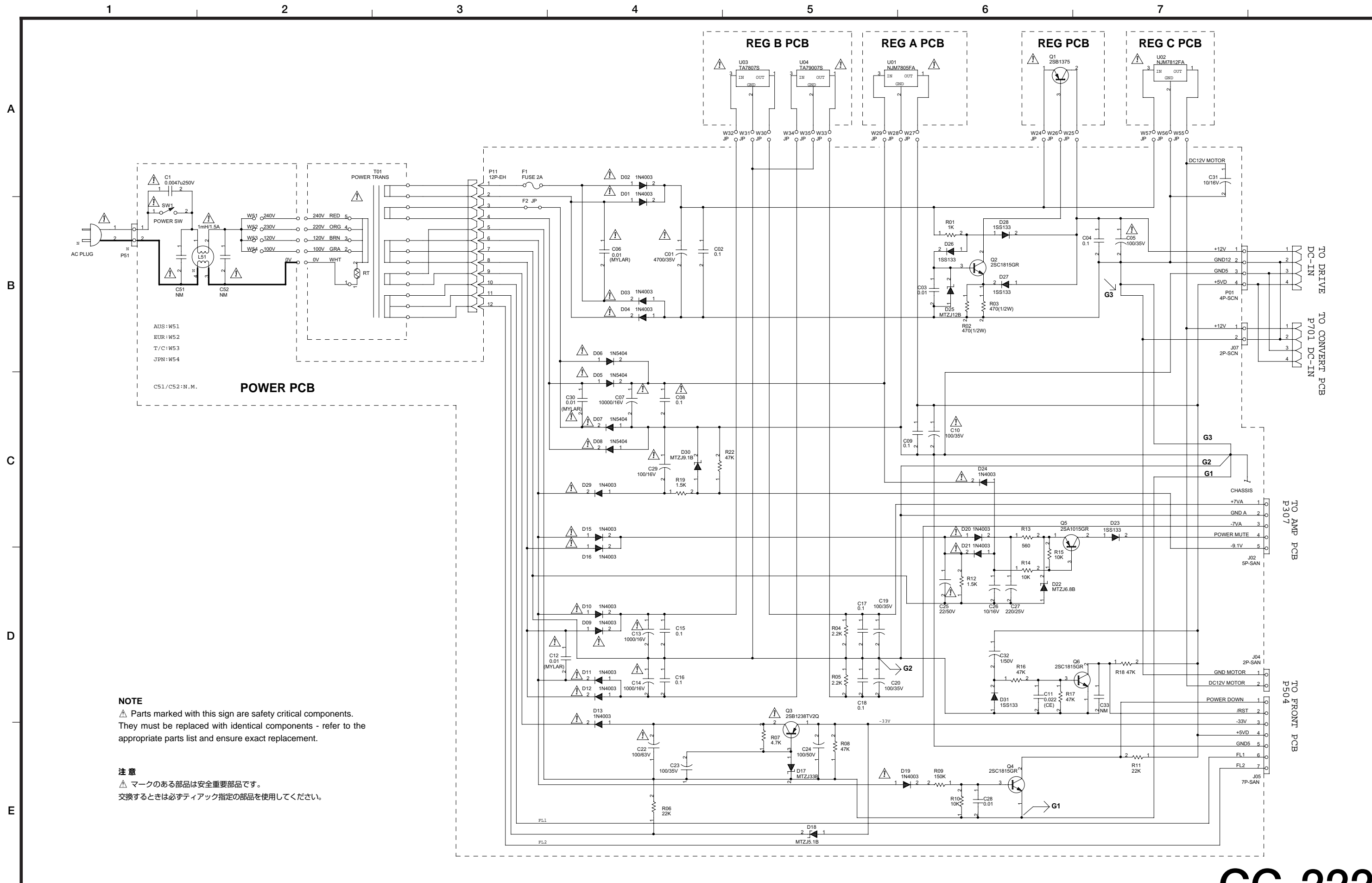

NOTE
 ⚠ Parts marked with this sign are safety critical components.
 They must be replaced with identical components - refer to the
 appropriate parts list and ensure exact replacement.

注意
 ⚠ マークのある部品は安全重要部品です。
 交換するときは必ずティアック指定の部品を使用してください。