

CONTENTS 目次

MAIN (1/3).....	2
MAIN (2/3).....	3
MAIN (3/3).....	4
FRONT PCB.....	5
SYS (1/3) : AUDIO SECTION	6
SYS (2/3) : DIF&FRONT-IF SECTION	7
SYS (3/3) : MPU SECTION	8
OUTPUT	9
PHONE / MONITOR	10
POWER / V-SELECT	11
CPU	12
SLIM / SENSOR.....	13
PATA / SATA.....	14
WIRING DIARGRAM	15

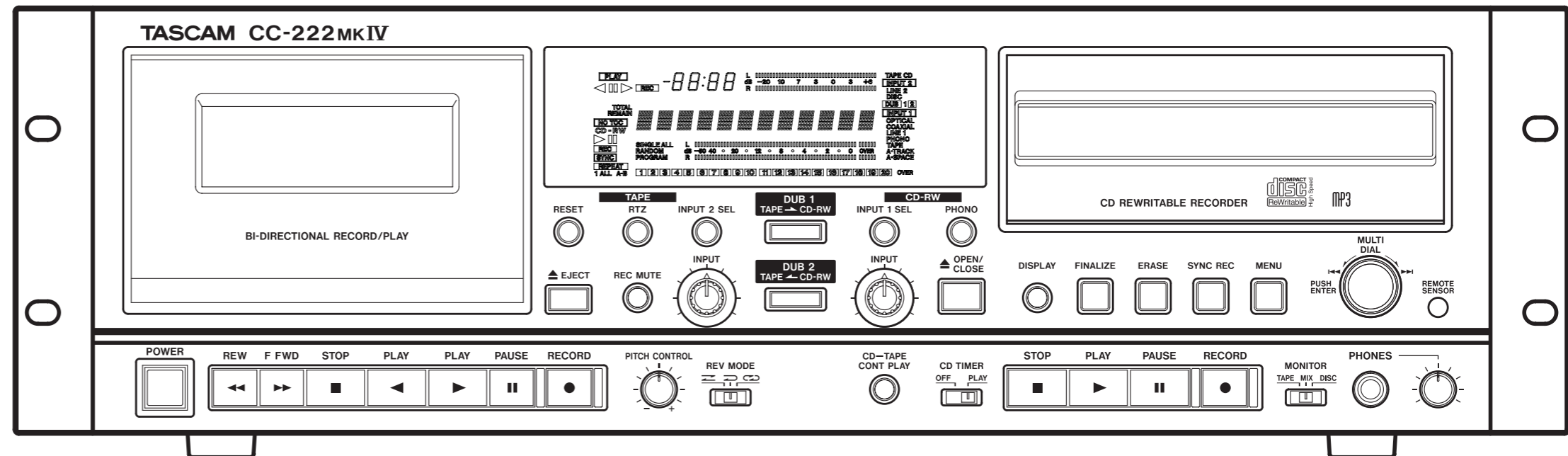

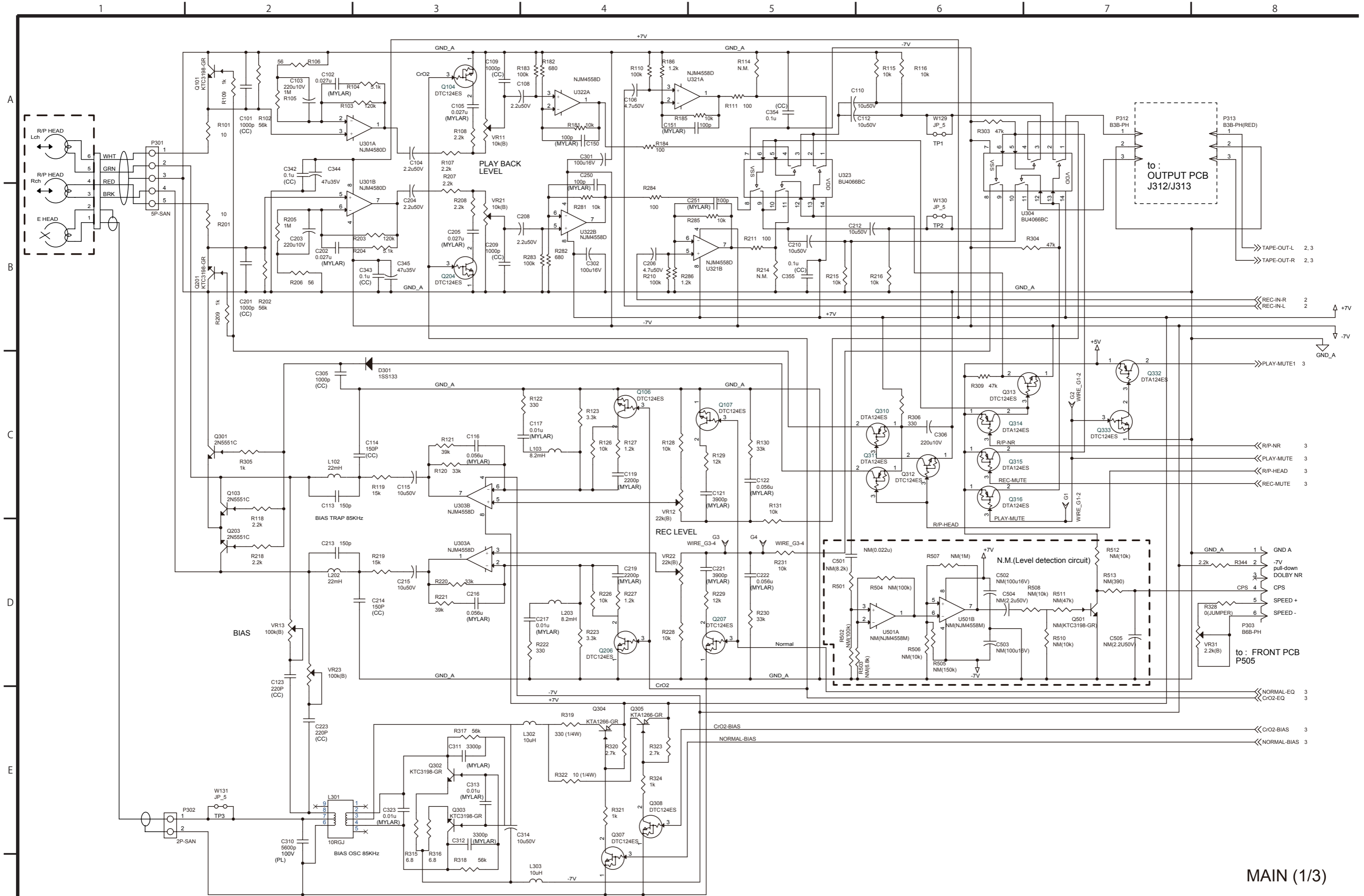

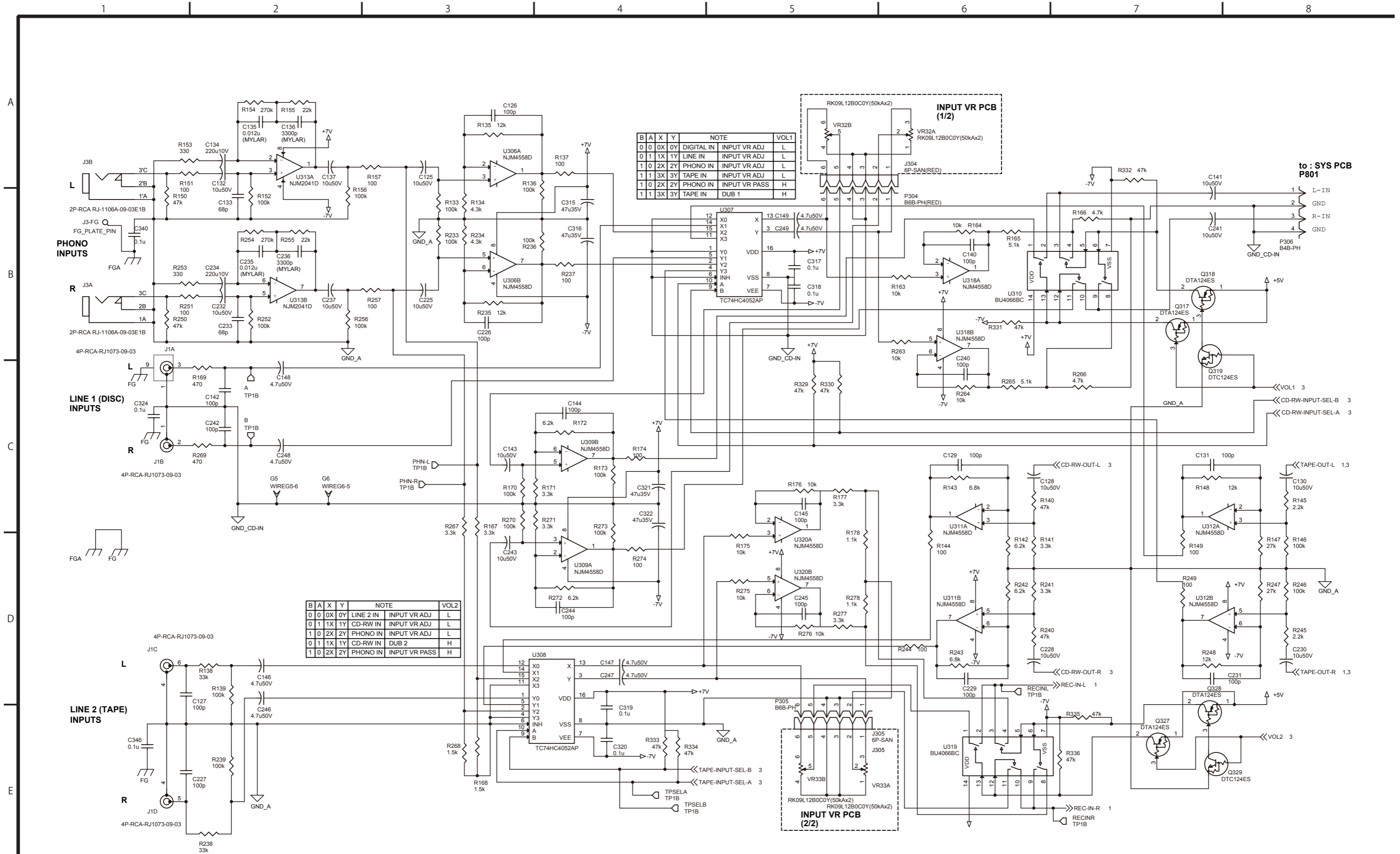

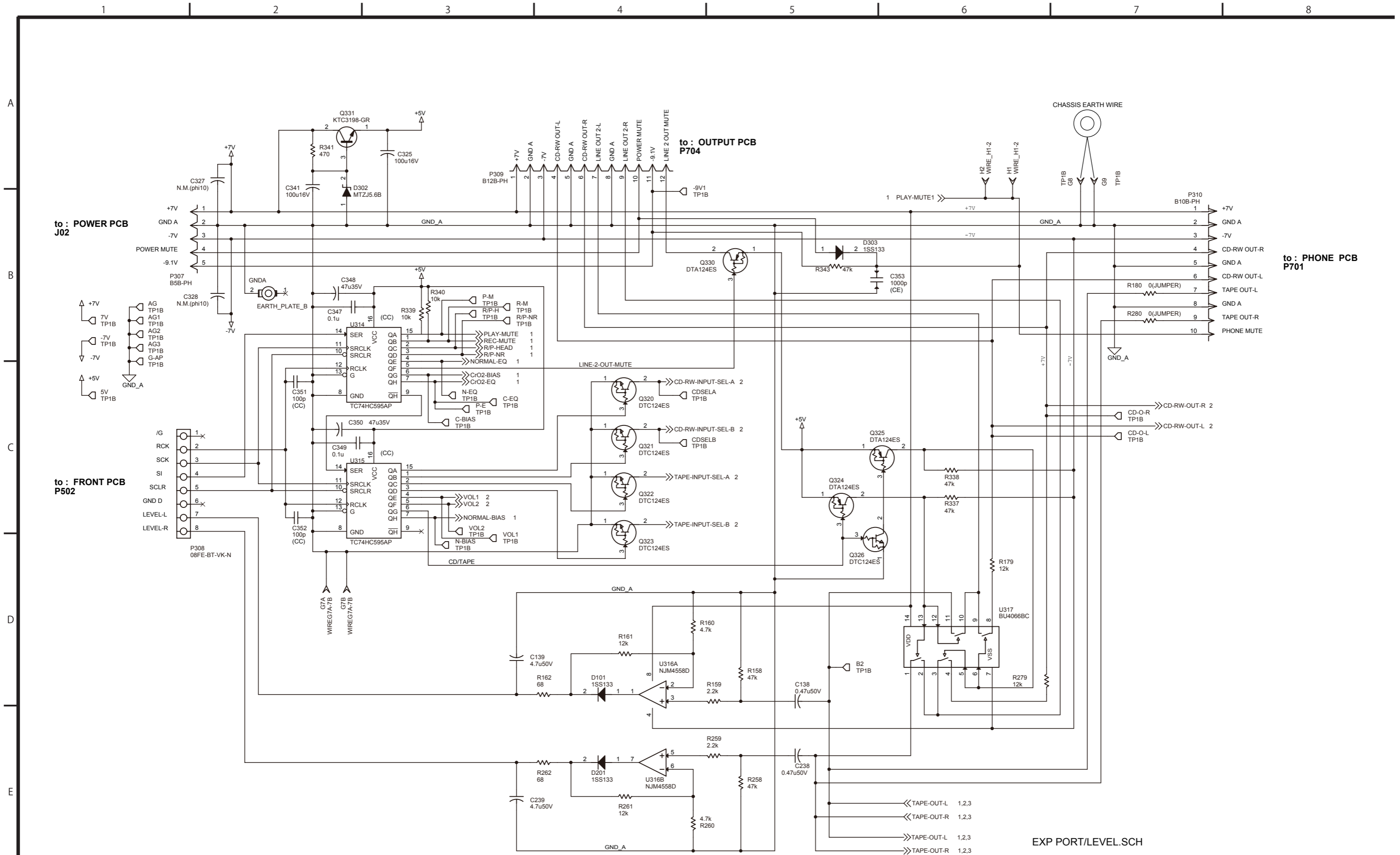

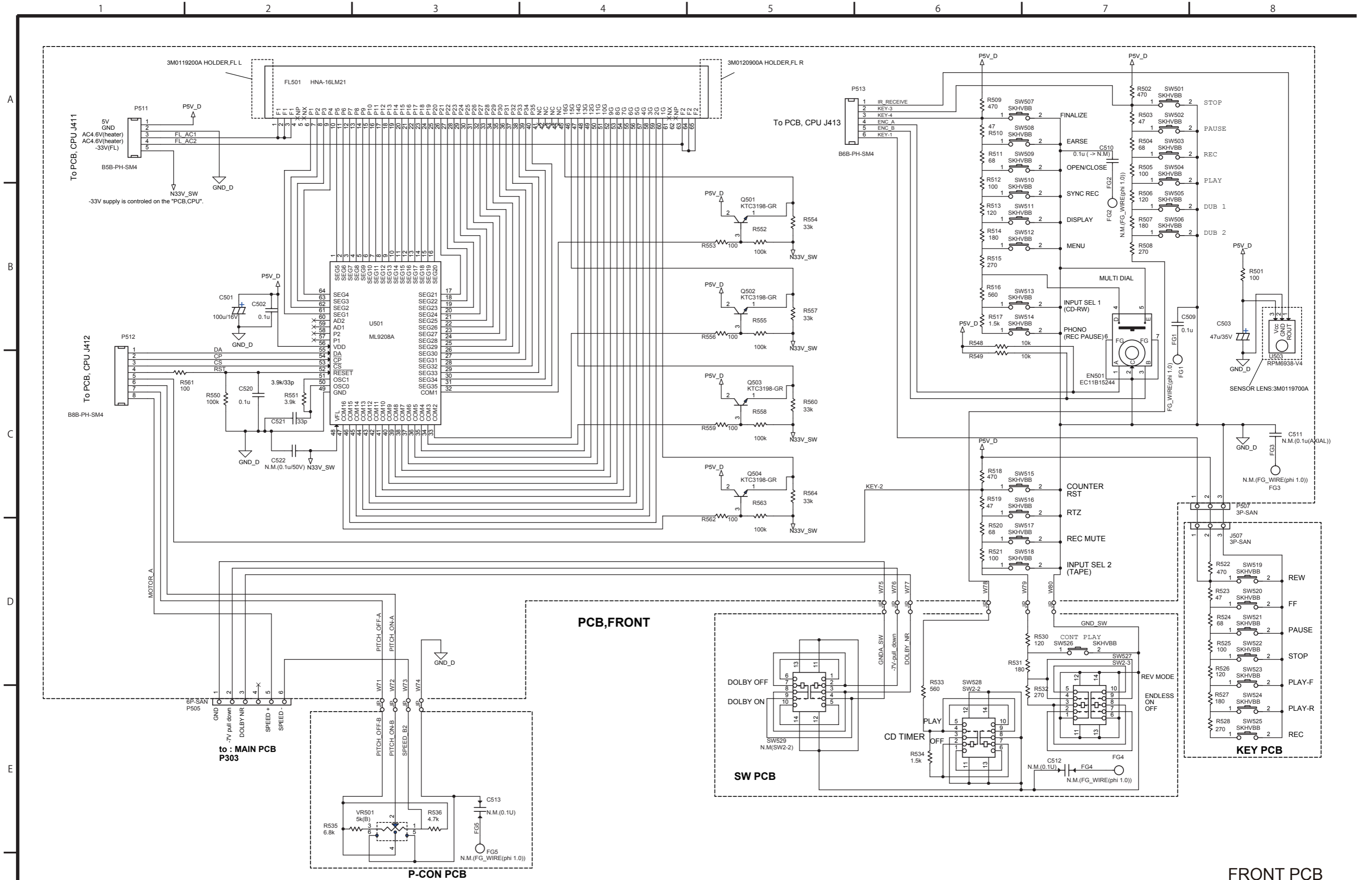

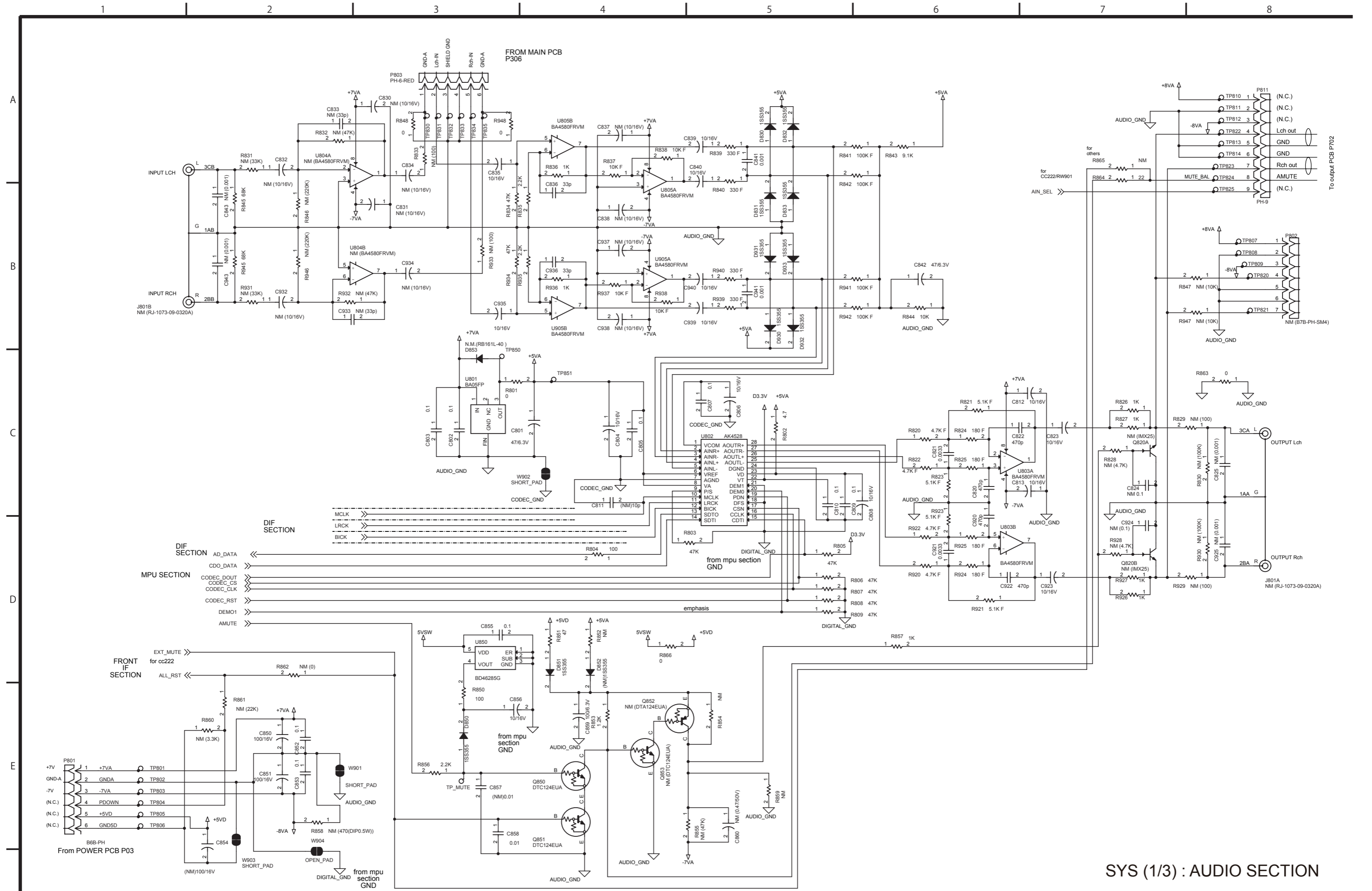

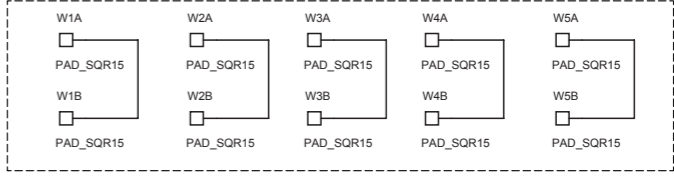
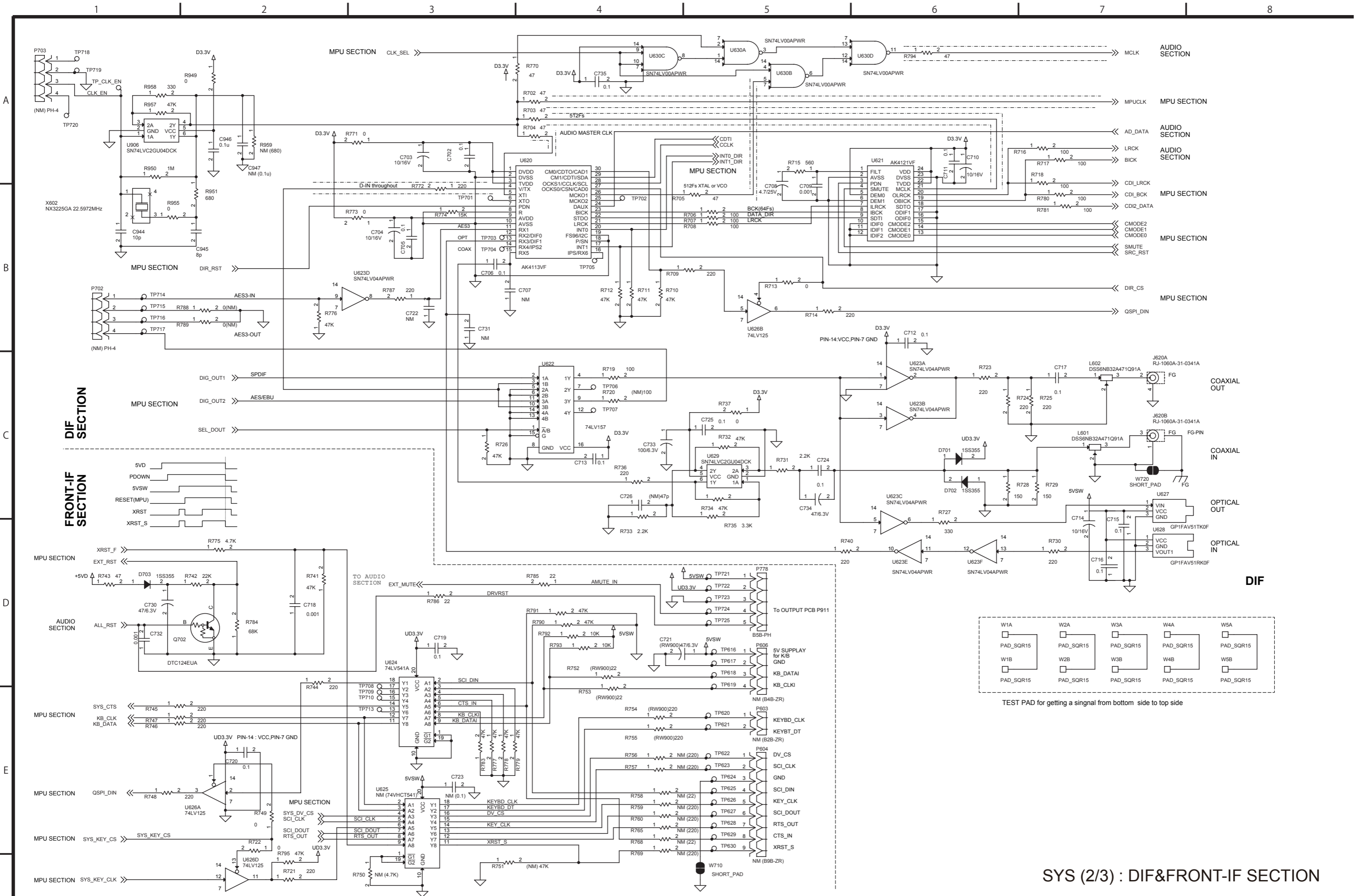

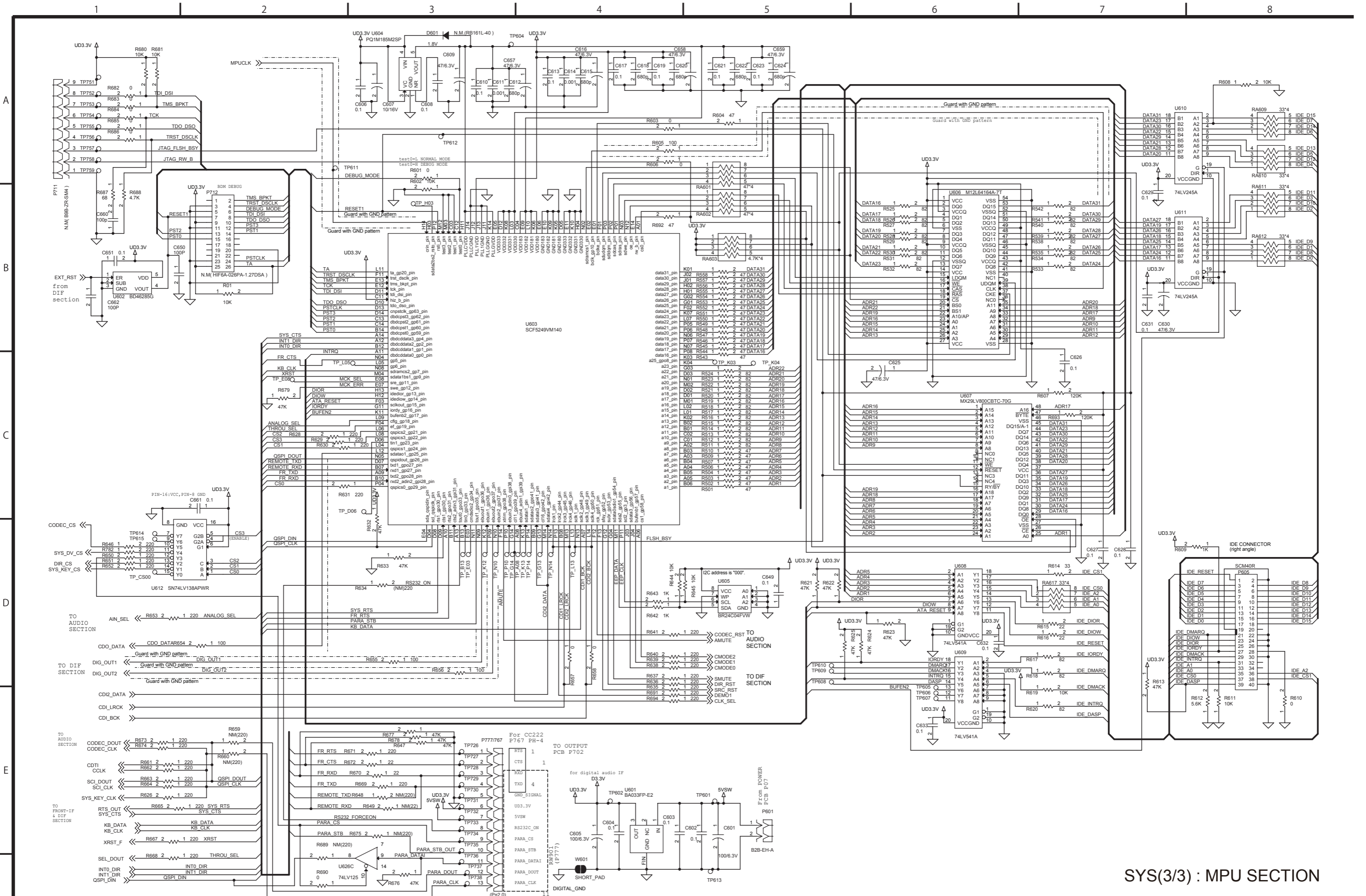

SYS(3/3) : MPU SECTION

1 2 3 4 5 6 7 8

A

B

C

D

E

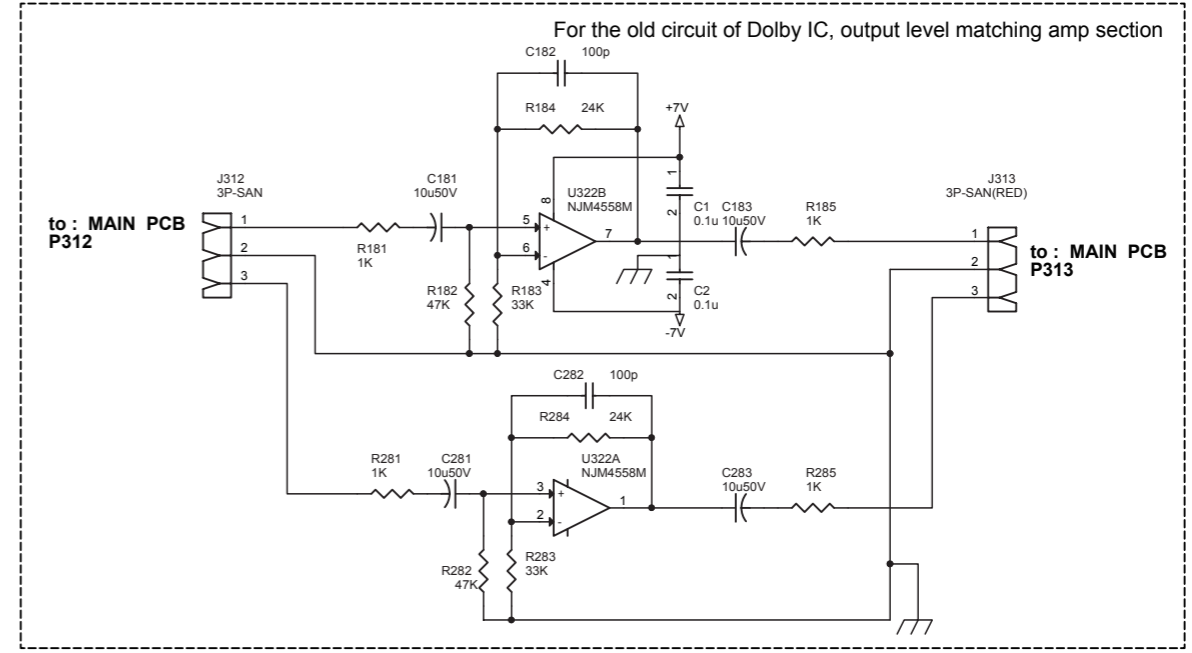
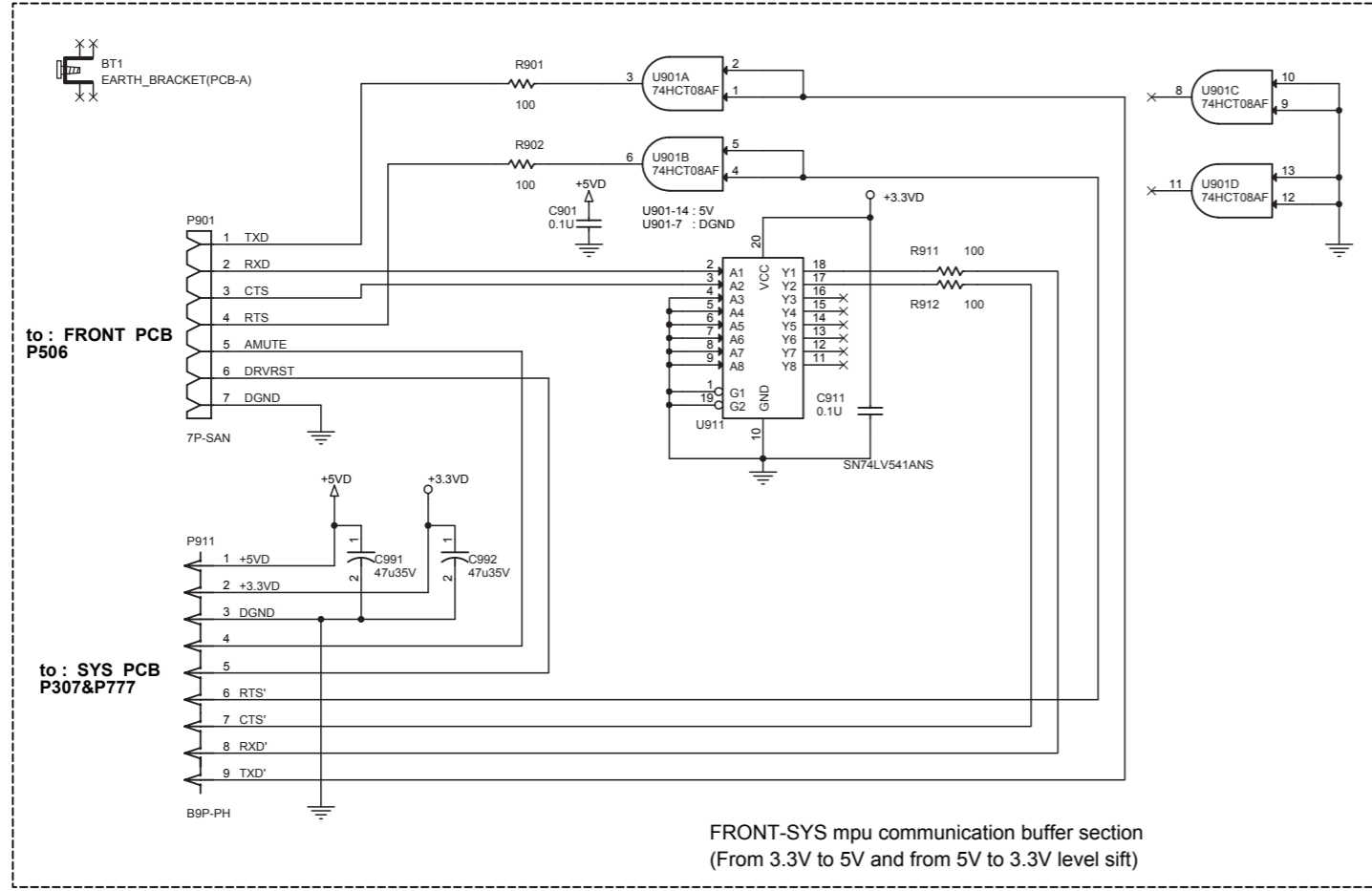
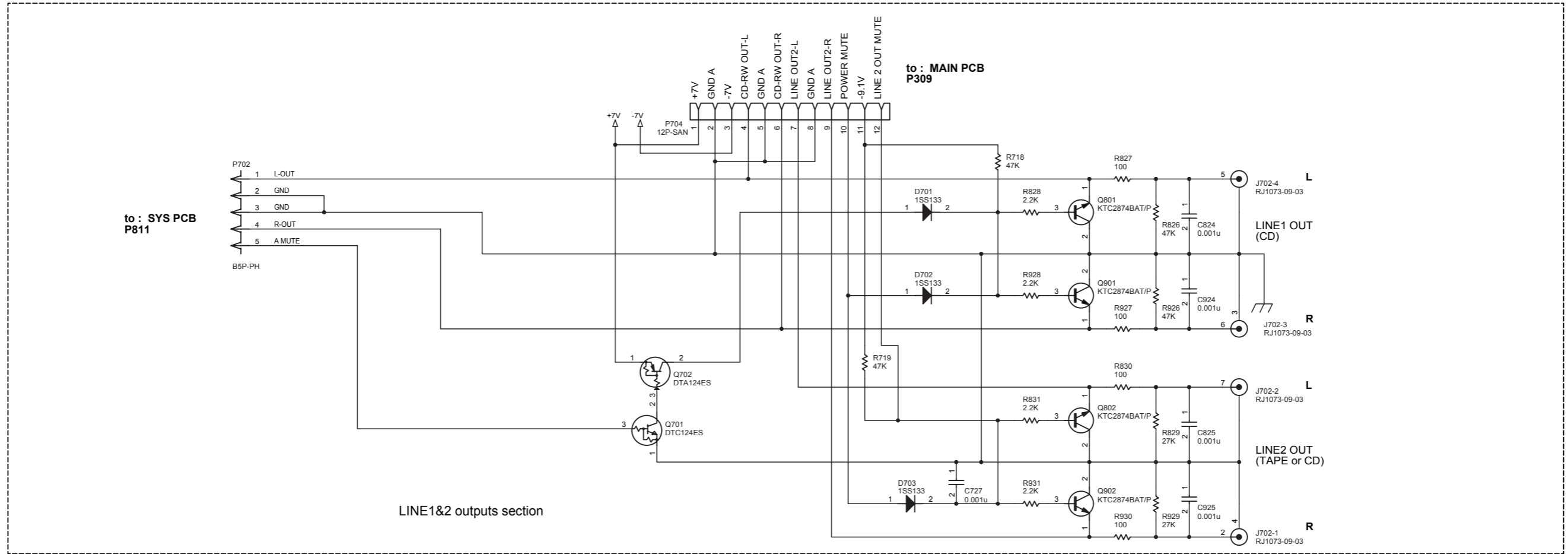

1 2 3 4 5 6 7 8

A

B

C

D

E

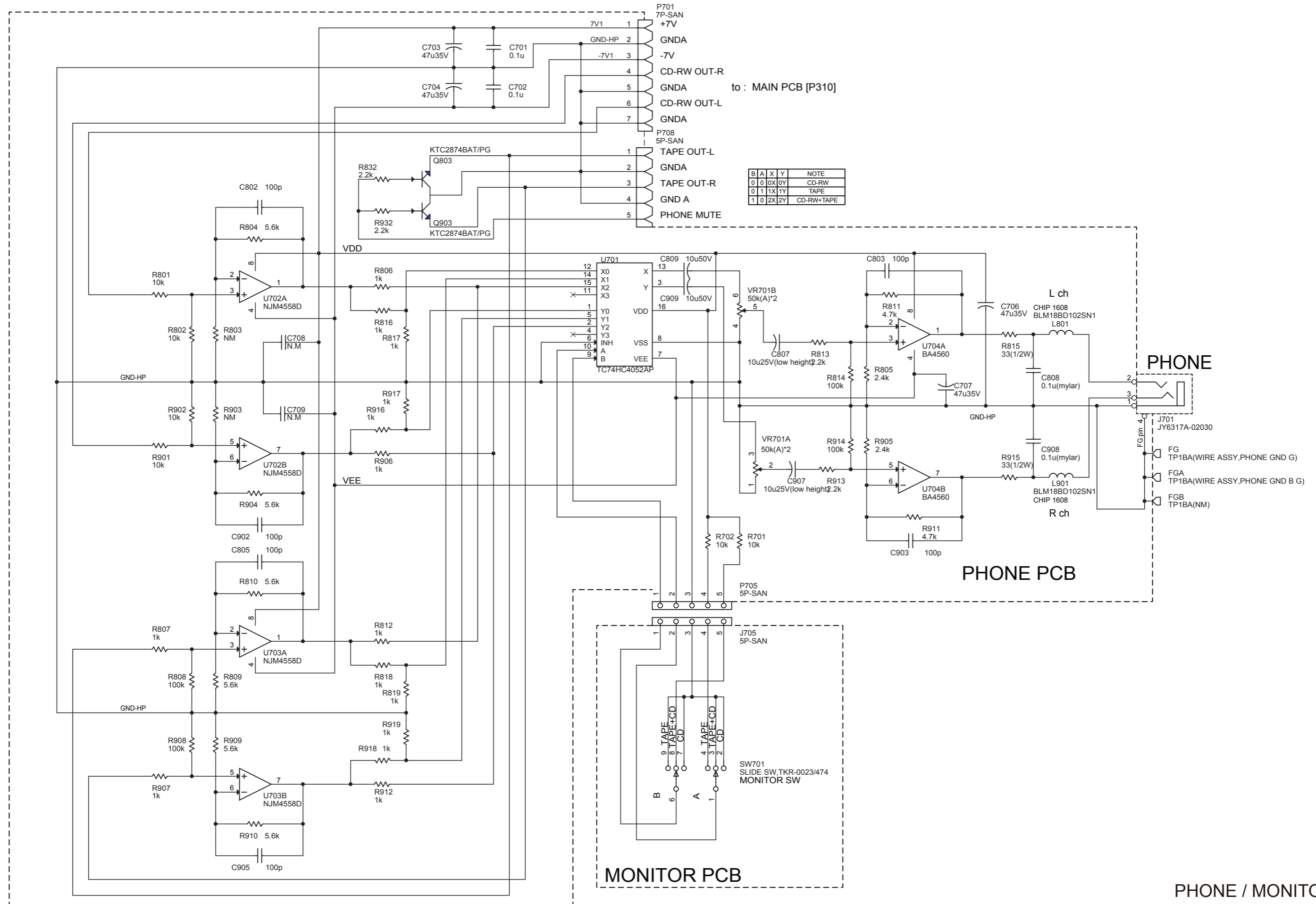

B	A	X	Y	NOTE
0	0	0	0	CD-RW
0	1	1	1	TAPE
1	0	2	2	CD-RW+TAPE

to : MAIN PCB [P310]

PHONE

PHONE PCB

MONITOR PCB

PHONE / MONITOR

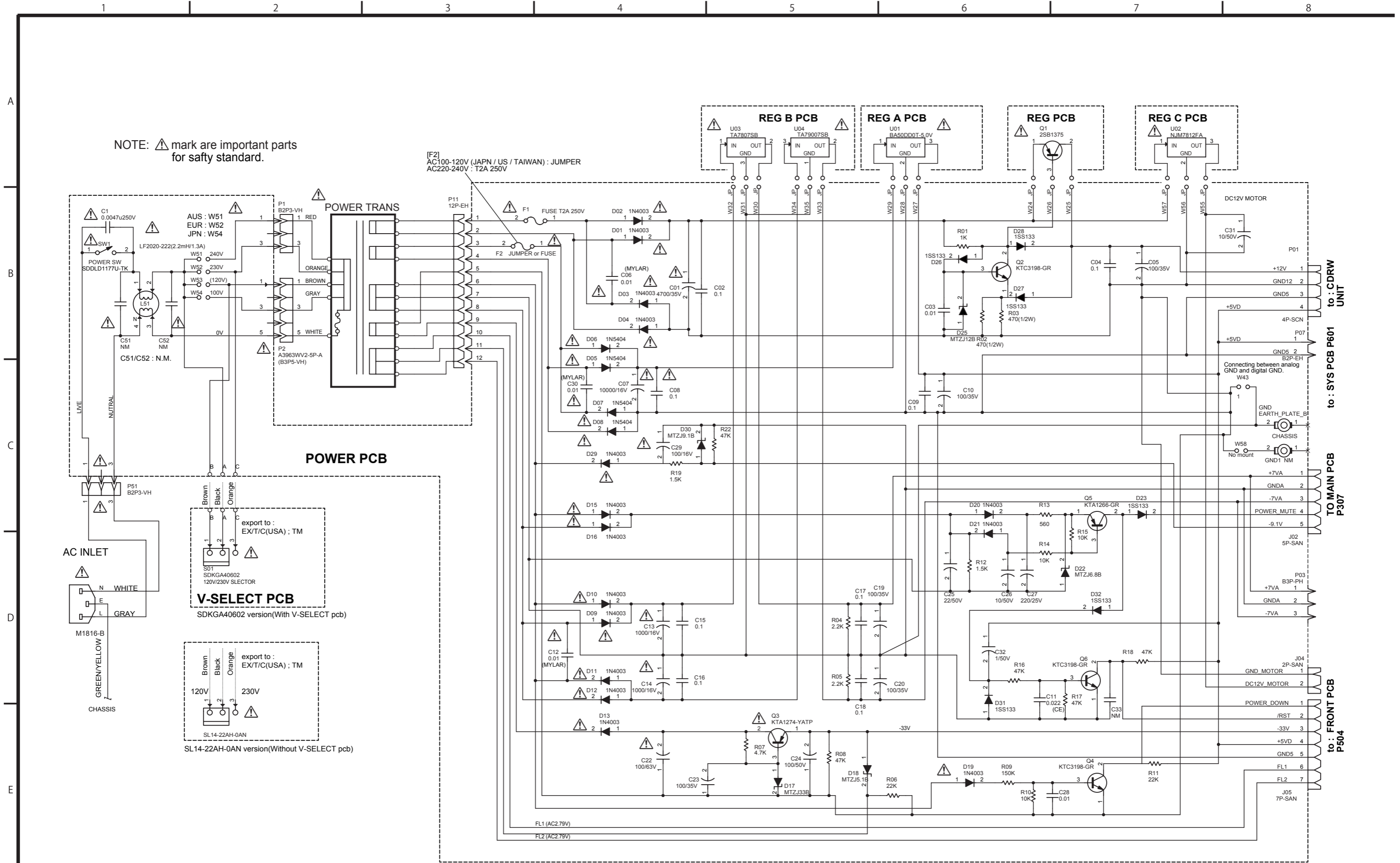

A

B

C

D

E

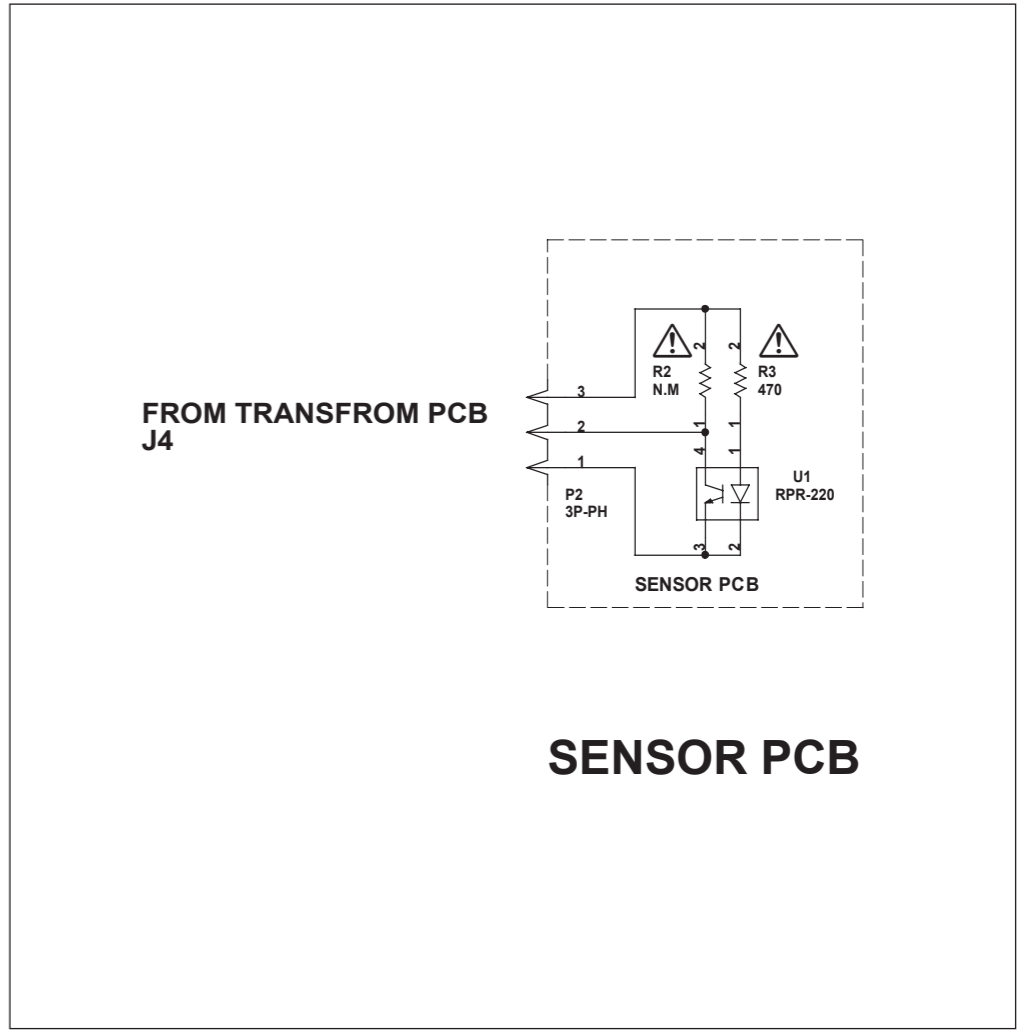
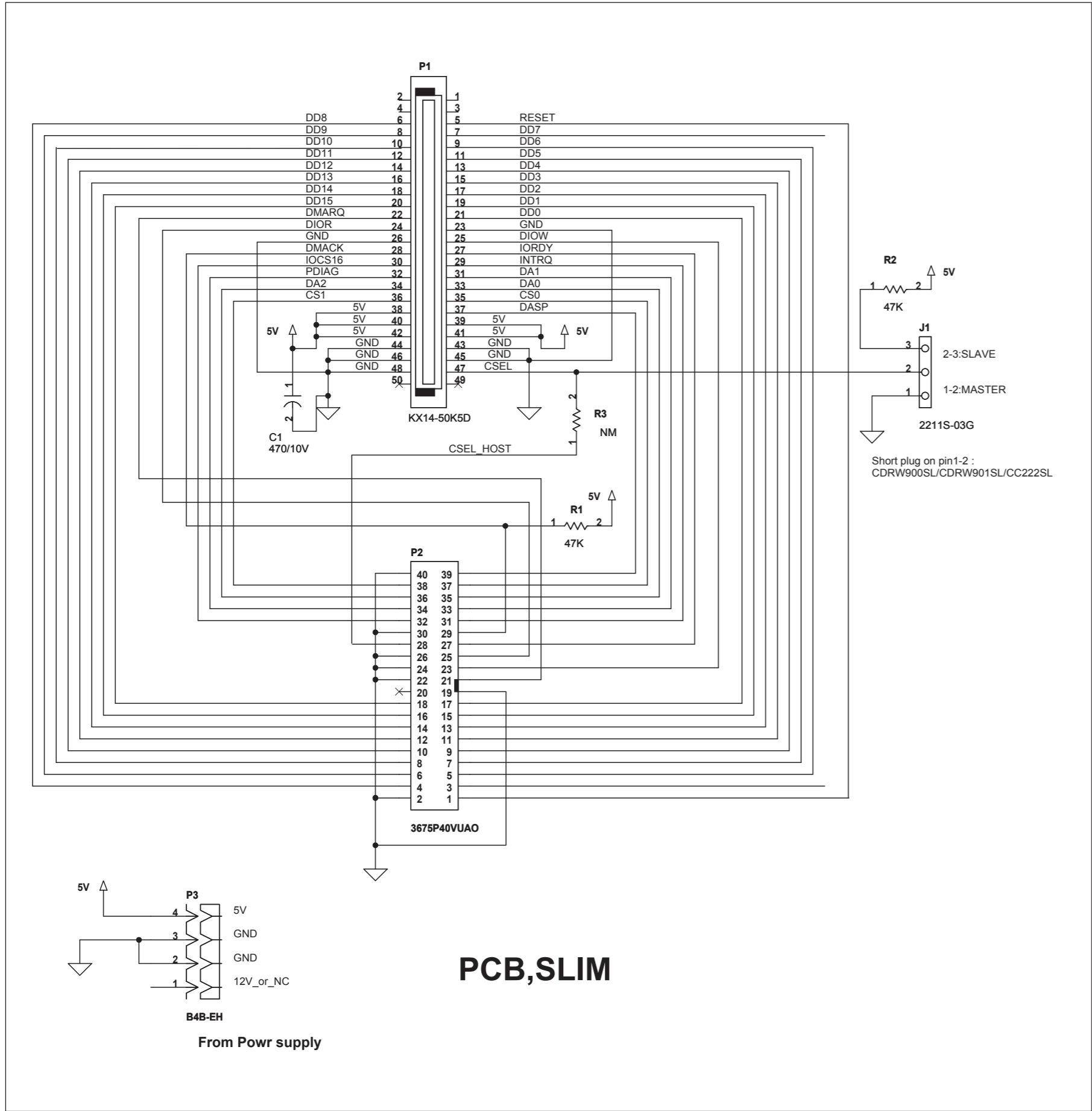

1 2 3 4 5 6 7 8

A

B

C

D

E

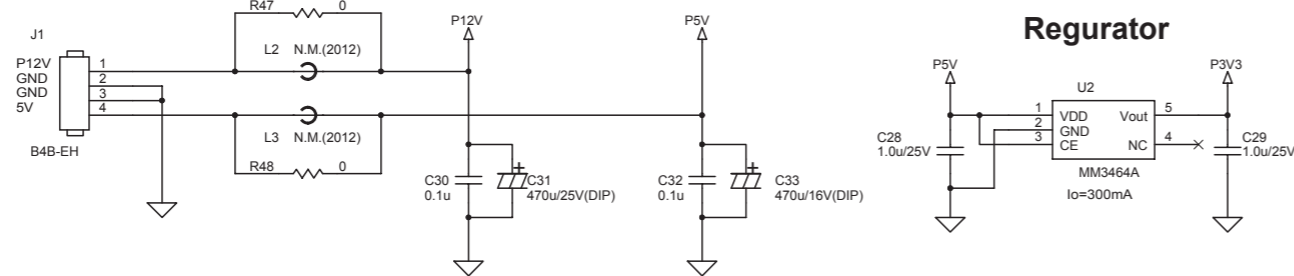
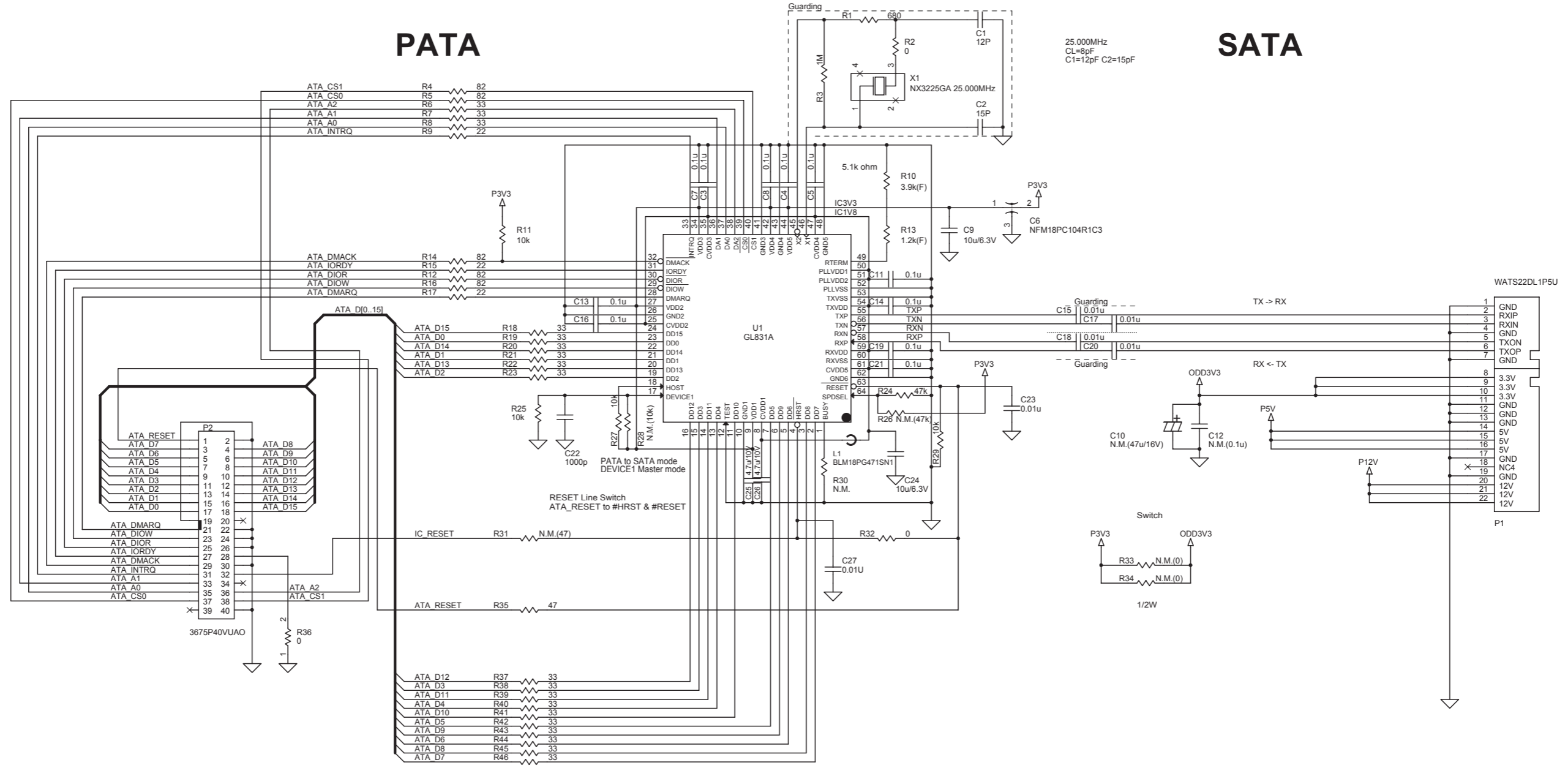

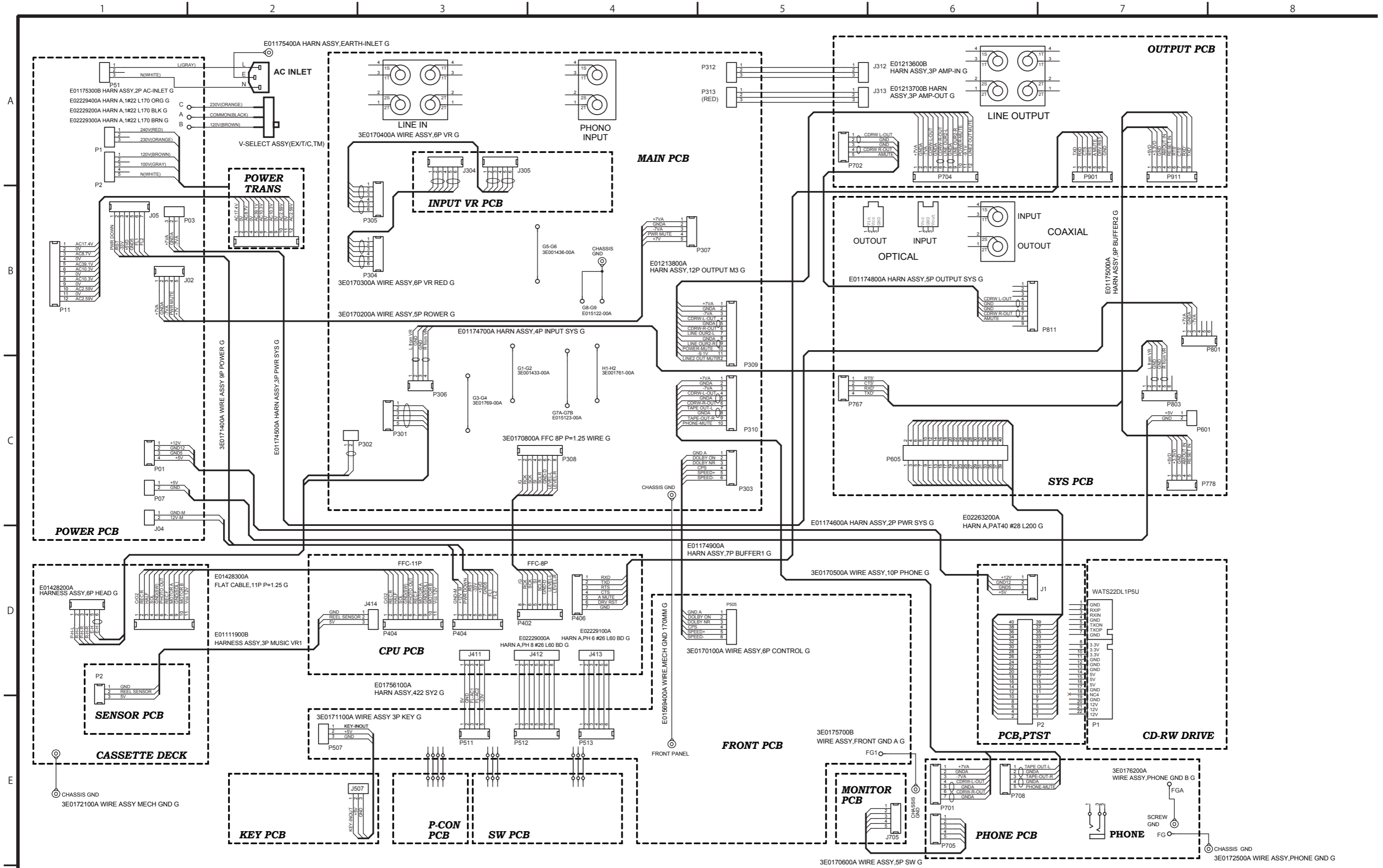

WIRING DIAGRAM