

CONTENTS 目次

MAIN (1/3)	2
MAIN (2/3)	3
MAIN (3/3)	4
FRONT	5
SYS (1/3)	6
SYS (2/3)	7
SYS (3/3)	8
OUTPUT	9
PHONE & MONITOR	10
POWER & V-SELECT	11
WIRING	12

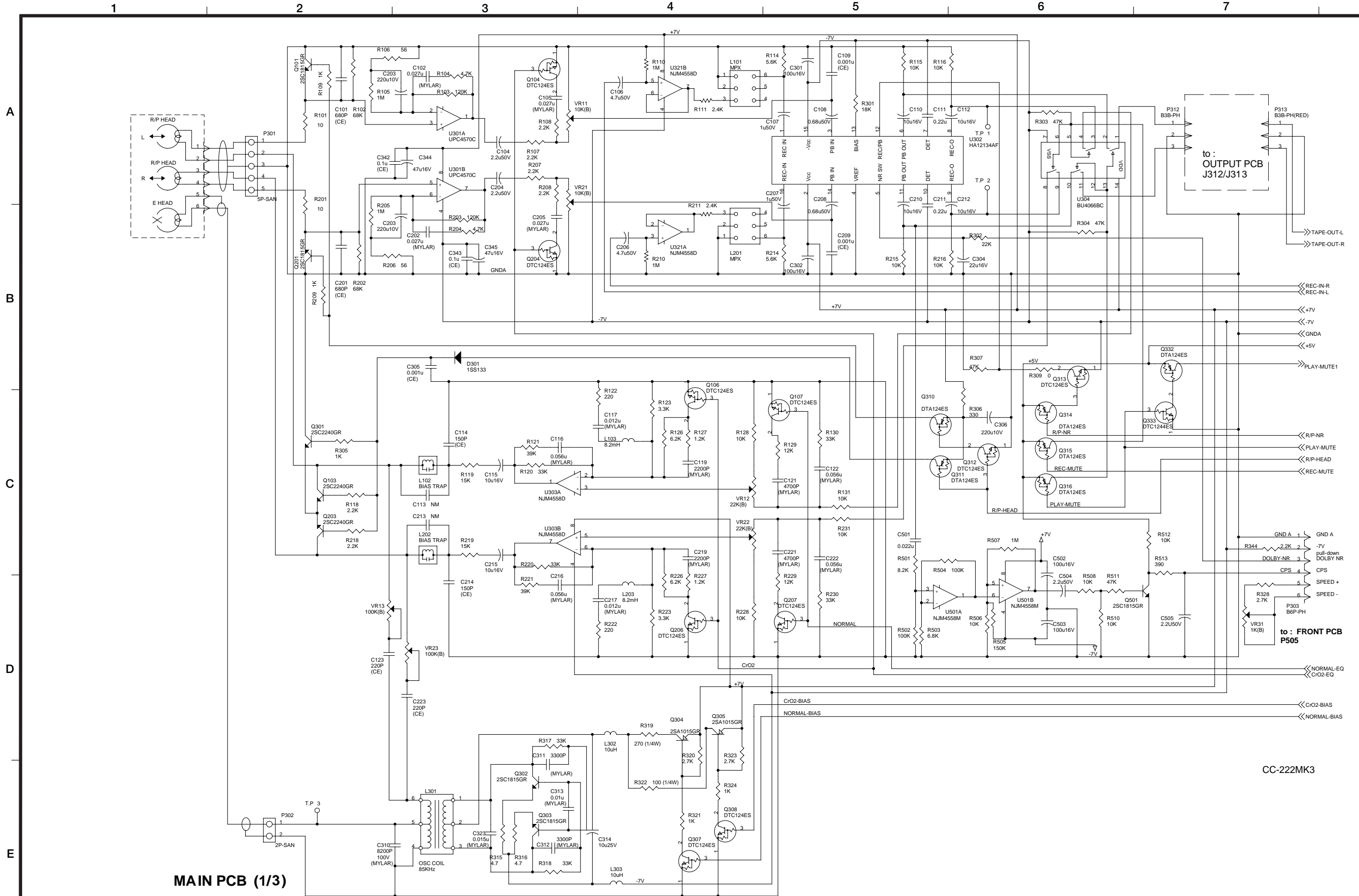

MAIN PCB (1/3)

CC-222MK3

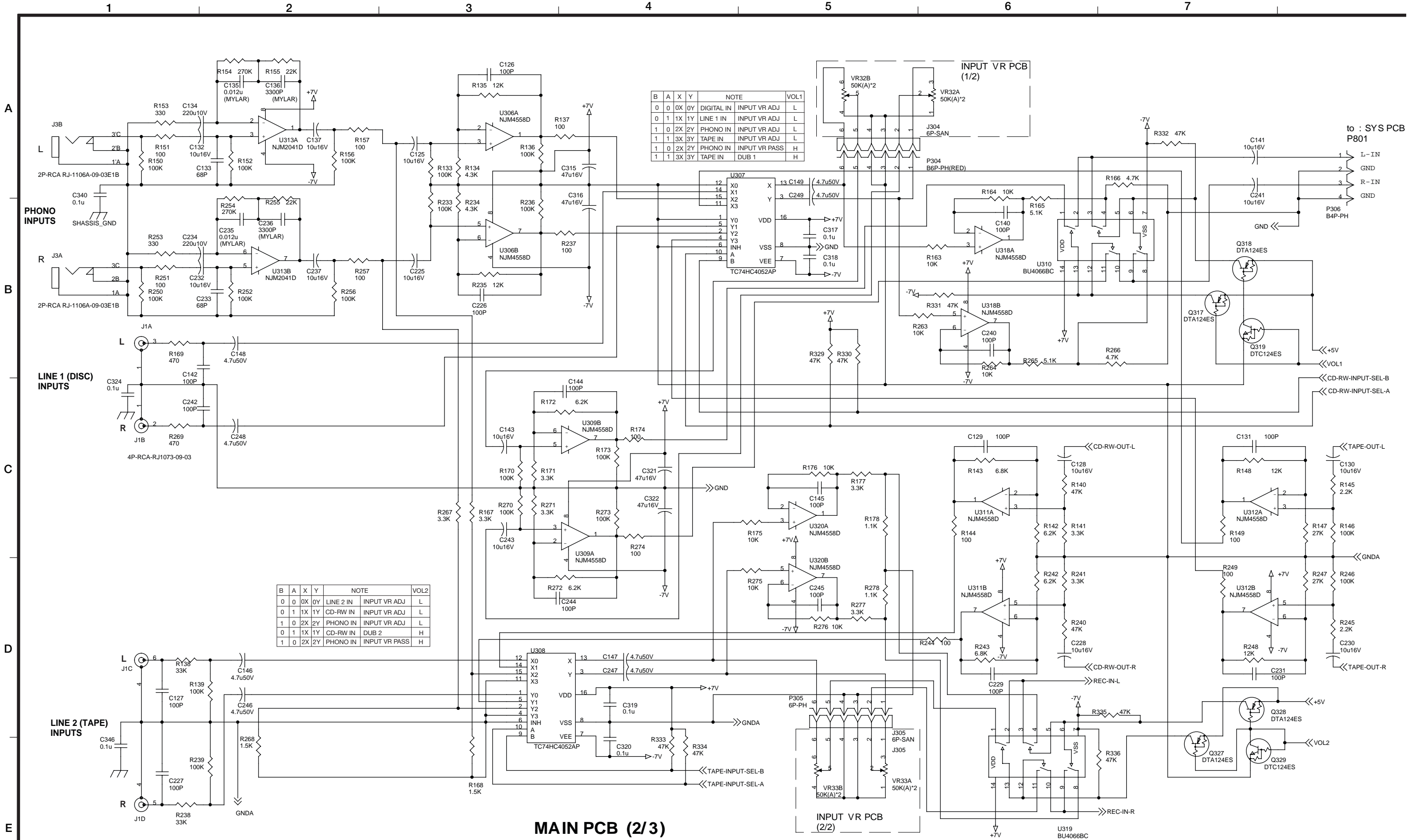

MAIN PCB (2/3)

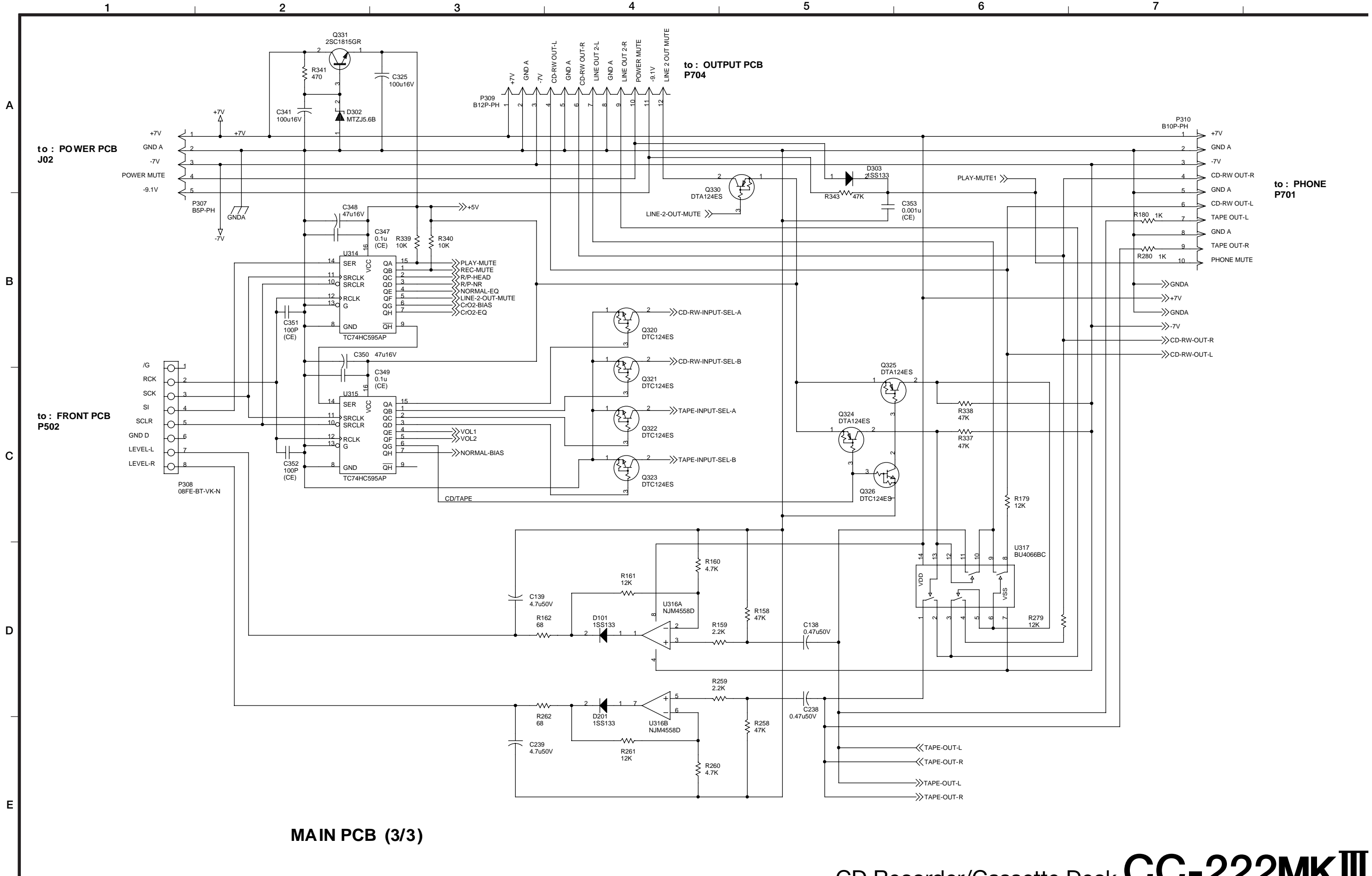

MAIN PCB (3/3)

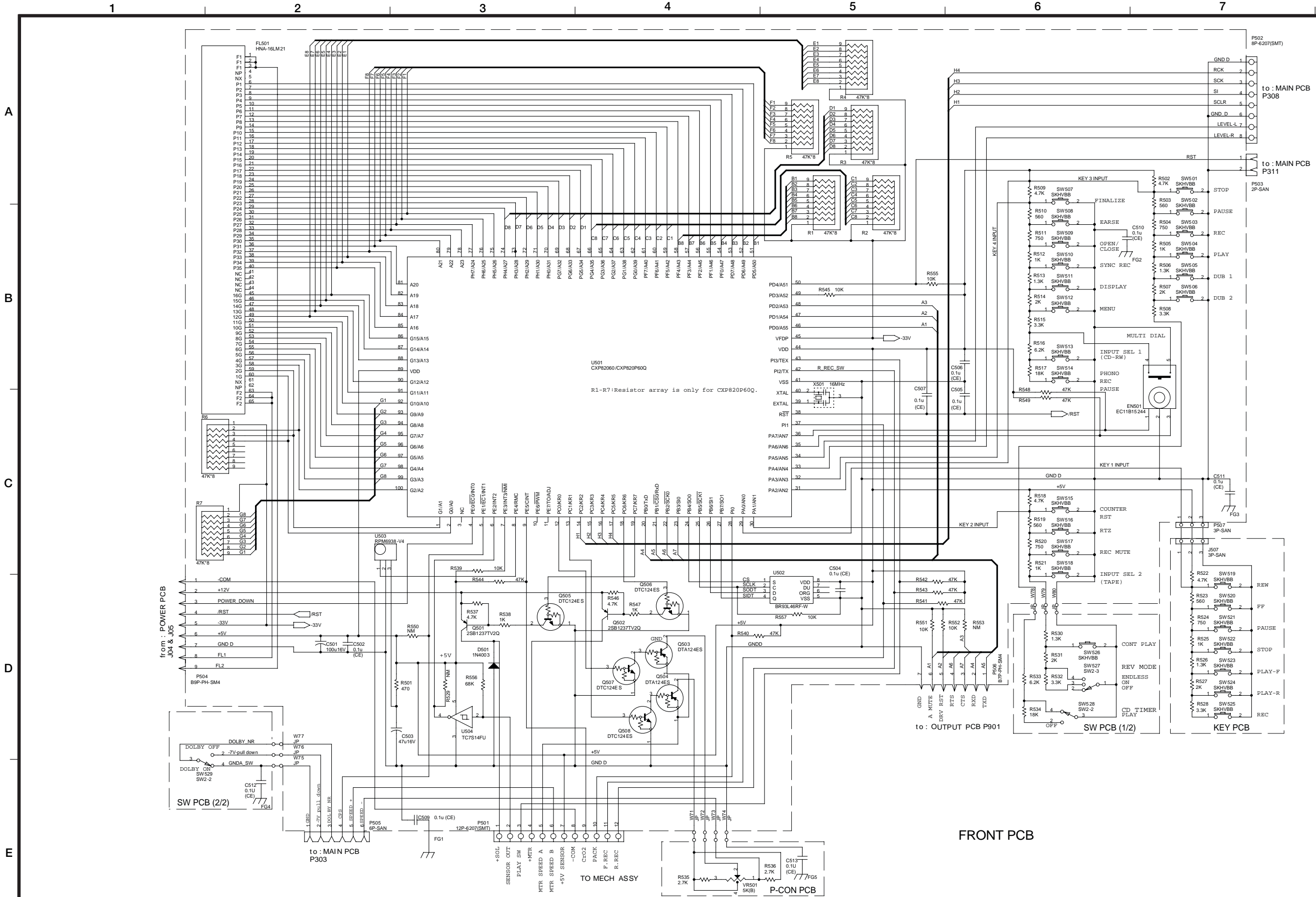

FRONT PCB

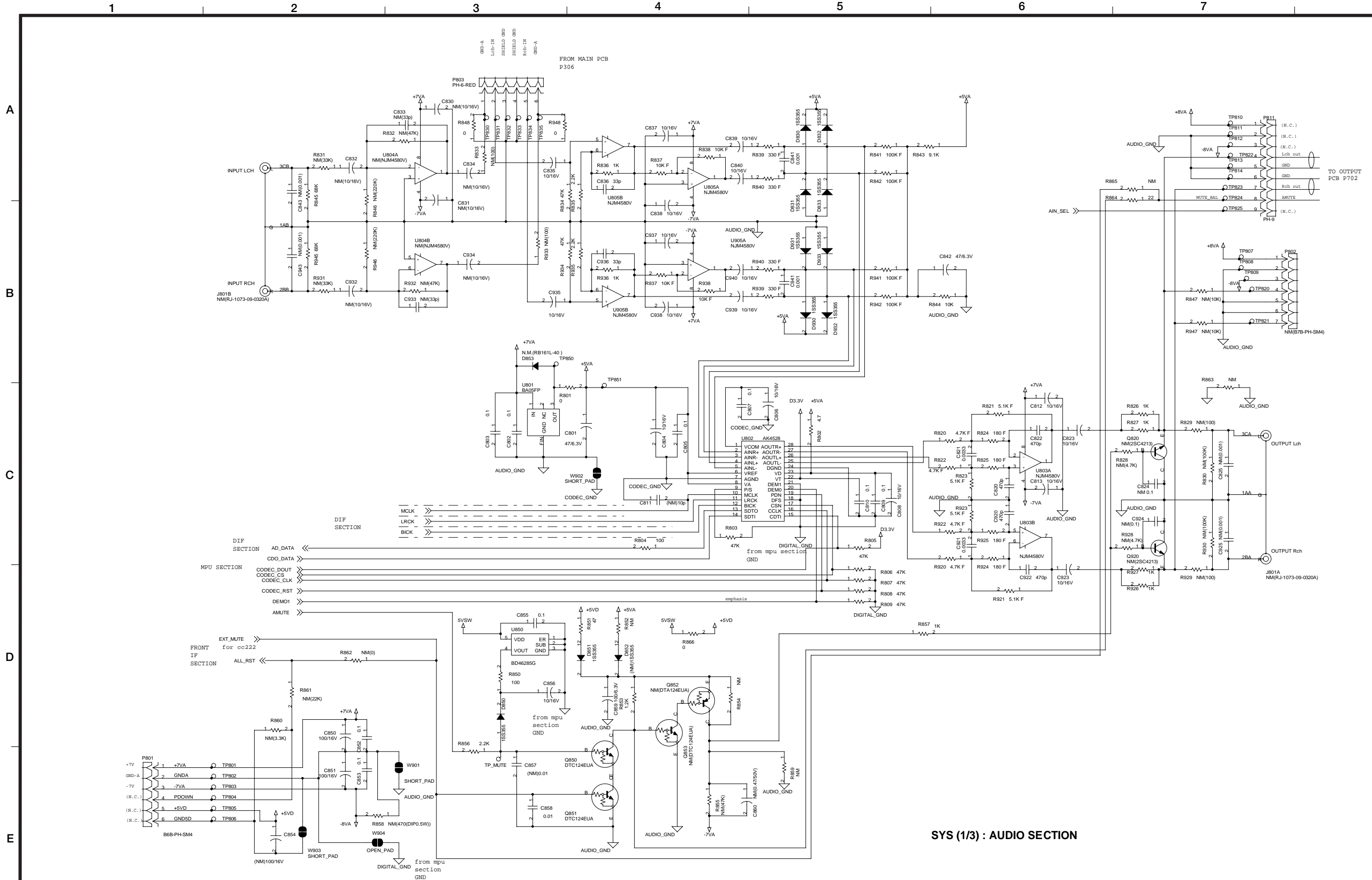

SYS (1/3) : AUDIO SECTION

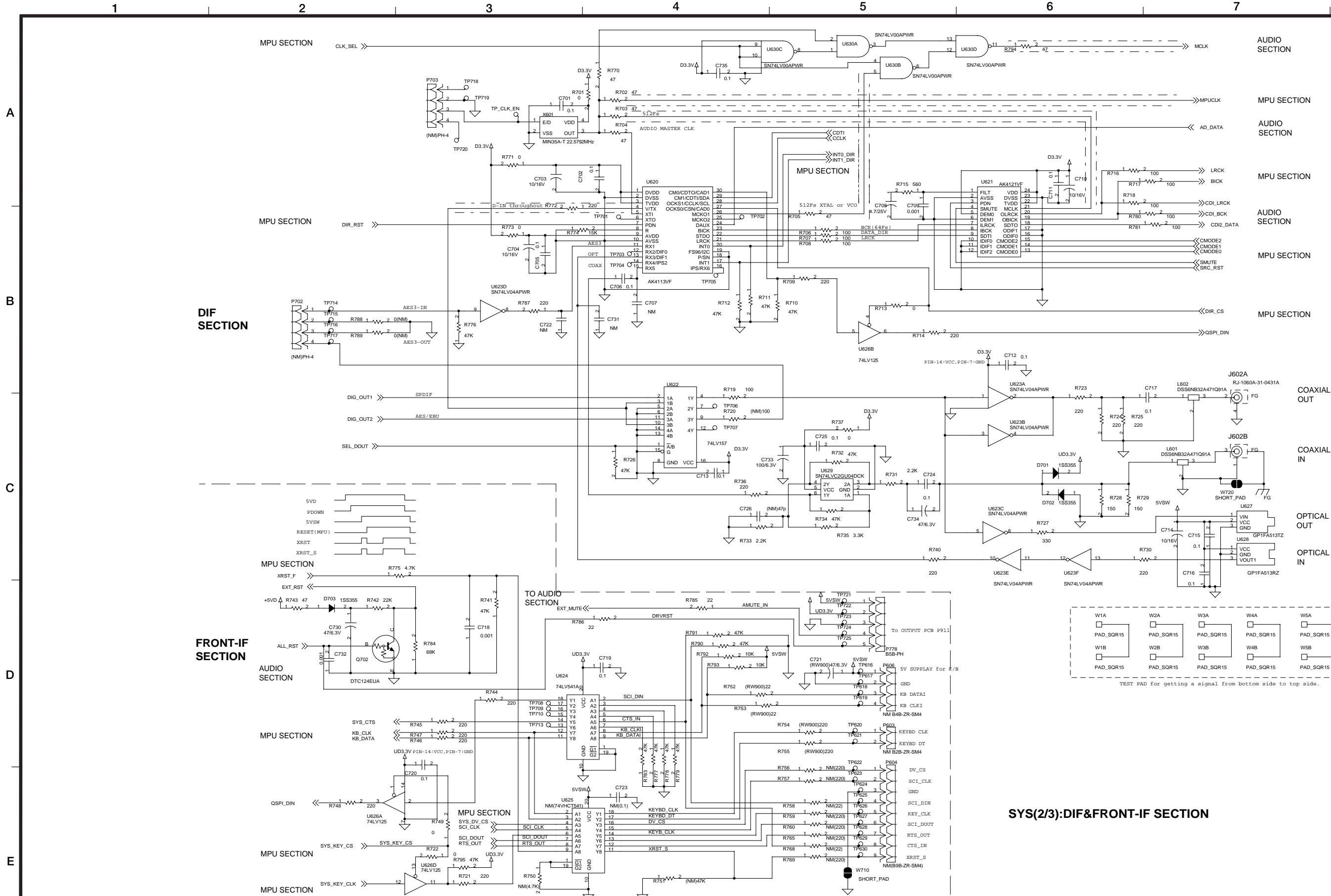

SYS(2/3):DIF&FRONT-IF SECTION

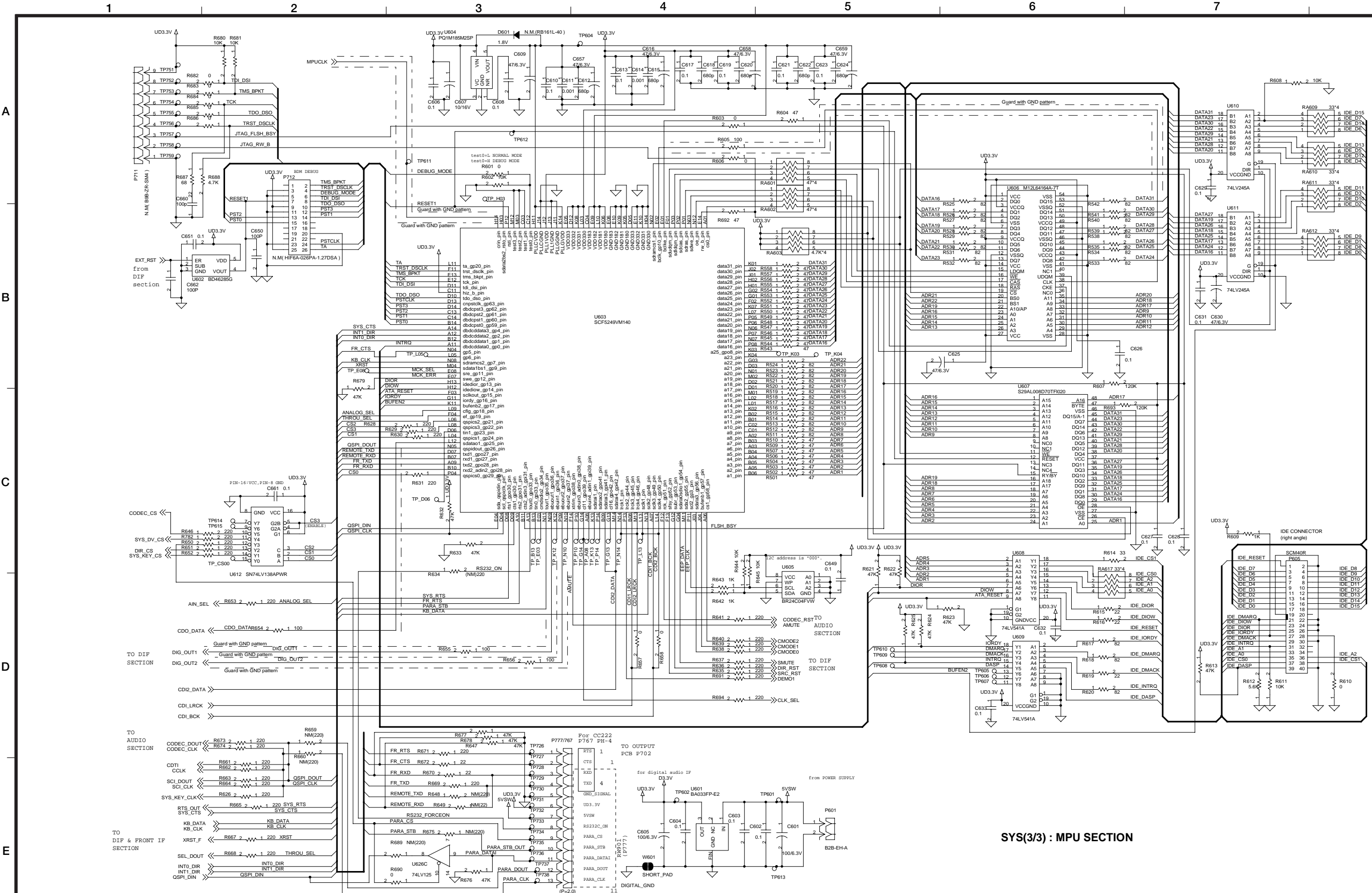

SYS(3/3) : MPU SECTION

