

TEAC**TECHNICAL INFORMATION****CD-P1120/1440/1820/CD-150, Change of Mechanism**No. **0026**

DATE 17th October 2000

Production of the original mechanism assy has been discontinued. Then mechanism has been changed as follows:

Ref No.	Original	New
31-00	CD93F8N P/No. 9A070707-00	CD93F8ND P/No. 9A084396-00
31-02	CD94V5 P/No. 9A070741-00	DA11 P/No. 9A084395-00

* Ref No. in above table is of CD-P1820 service manual.

Ref. 31-00

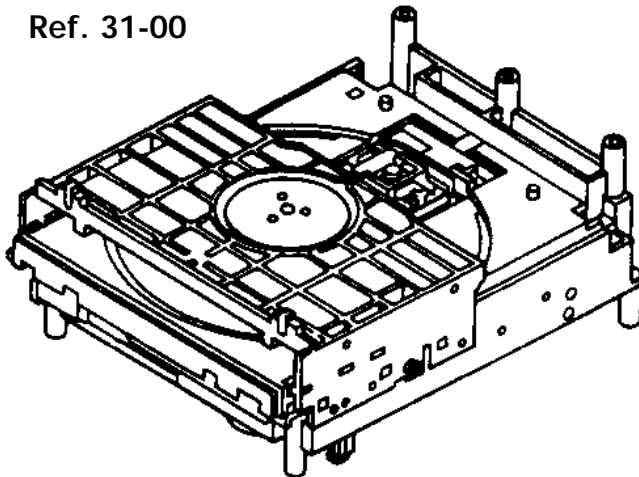

Ref. 31-02

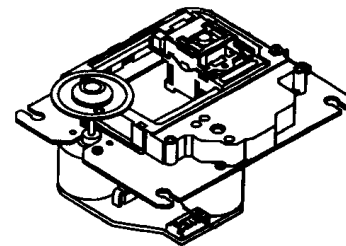
**Notice:**

- 1) Original and new are incompatible.
- 2) Original mechanism is still available at TEAC Parts Supply Center.
- 3) Independent parts for new mechanism are not supplied.

New mechanism has been mounted on the following products:

CD-P1120	3AB9965143 and higher
CD-P1440	1AC9Y17636 and higher
CD-P1820	1AA9914261 and higher
CD-150	0100001 and higher

TEAC TECHNICAL INFORMATION

CD-P1120/1440/1820/CD-150, Change of Mechanism

No. 0507

DATE 10th August 2005

This information relates to previous Tech-Info No. 0026.

Mechanism (Mech) Assy used for the captioned model has been changed over 3 times as follows:

1st generation	2nd	3rd
9A07070700 CD93F8N w/tray	9A08439600 CD93F8ND	Unable to supply
9A07074100 CD94V5 w/o tray	9A08439500 DA11	9A08884400 DA11N

The Mech Assy of the 1st & 2nd generation are no longer available and this information introduces Service Kit to use the 3rd generation Mech Assy w/out tray (Traverse unit). The major difference between the generations is Pickup has been changed to new one that is FFC type. Then, a PCB Assy becomes in need to convert FFC to wires to fit the original connectors. And that is realized now with required mechanical attachments as Service Kit described below and place order for the following 2 items:

9A08884400 DRIVE MECH DA11N

V00140100A SERVICE KIT for DA11N

9A08454500	PCB Assy, Connector	x 1 pce
9A08438600	Frame, Lifter ABS	x 1 pce
9A08438700	Cushion, Rubber Brown	x 2 pcs
9A08438800	Cushion, Rubber Orange	x 2 pcs
5760707700	Screw, B tite SEMS M3x10	x 2 pcs
5783603008	Screw, P tite BIN M3x8	x 2 pcs

Follow the illustration and pictures for practical mounting:

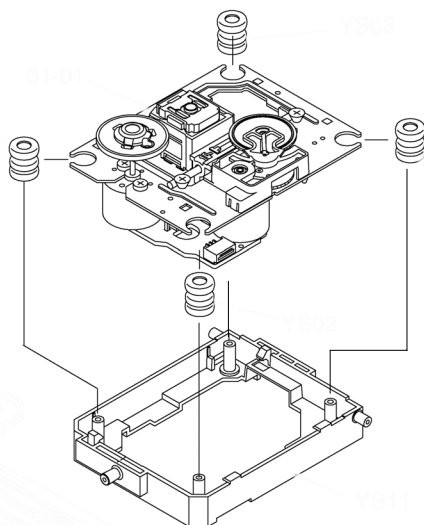

DRIVE MECH DA11N, 9A08884400

SERVICE KIT for DA11N, V00140100A

Lifter Frame ABS

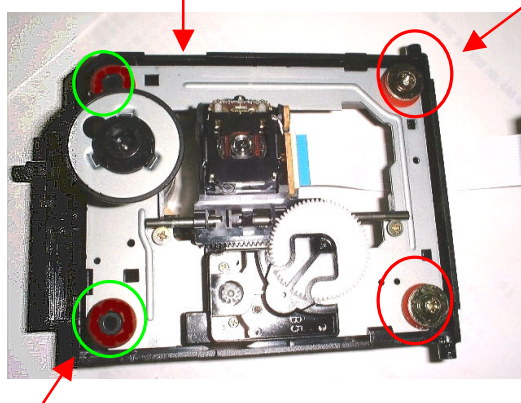

Rubber Cushion Brown x 2 at Front side
Set through the boss provided with no screw

Rubber Cushion Orange x 2 at Rear side
Set with 2 screws 5760707700 SEMS M3x10

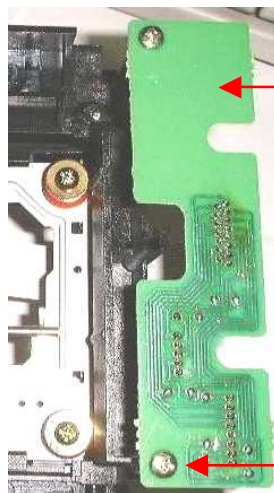

Connector PCB Assy
9A08454500

Secure by 2 screws
5783603008 BIN M3x8

The following change at Servo circuit in the Main PCB Assy is required to cope with the new pickup:

CD-P1440/1820/CD-150 - R118 (8.2k) to 5.6k
 CD-P1120 - R740 (6.8 k) to 8.2 k, R711 (10 k) to 6.8 k, R738 (5.6 k) to 1 k, R721 (10 k) to 6.8 k,
 R710 (6.8 k) to 3.9 k and C723 (22 uF/16V) to 47 uF/10V

CP-P1440, CD-P1820 and CD-150

CD-P1120

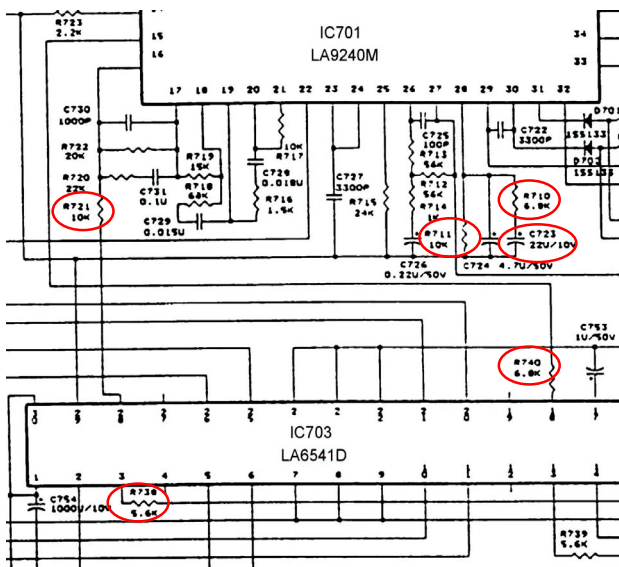
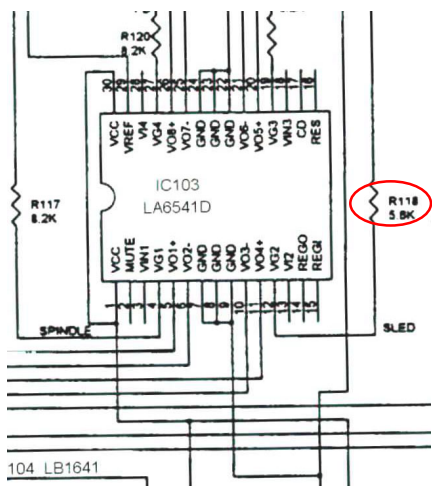

104 LB1641