

TASCAM

TEAC Professional Division

SERVICE MANUAL

CD-RW5000

CD Rewritable Recorder

NOTES

- PC boards shown are viewed from parts side.
- Parts marked with * require longer delivery time.
- The parts with no reference number or no parts number in the exploded views are not supplied.
- As regards the resistors and capacitors, refer to the circuit diagrams contained in the manual.
- Δ Parts marked with this sign are safety critical components. They must be replaced with identical components - refer to the appropriate parts list and ensure exact replacement.
- Parts of [] mark can be used only with the version designated.
[J]: JAPAN [US/C]: U.S.A./CANADA [K]: KOREA
[E]: EUROPE [UK]: U.K. [A]: AUSTRALIA

注意

- プリント基板は部品面が示されています。
- *印の部品は納期が若干かかります。
あらかじめご了承ください。
- 分解図に部番のない部品及び品番のない部品は供給しません。
- 標準の抵抗、コンデンサーは省略してあります。
回路図を参照してください。
- Δ は安全重要部品です。
交換する時は必ずティアック指定の部品を使用してください。
- 仕向先
[J]: JAPAN [US/C]: U.S.A./CANADA [K]: KOREA
[E]: EUROPE [UK]: U.K. [A]: AUSTRALIA

INSTRUCTIONS FOR SERVICE PERSONNEL

BEFORE RETURNING APPLIANCE TO THE CUSTOMER, MAKE LEAKAGE-CURRENT OR RESISTANCE MEASUREMENTS TO DETERMINE THAT EXPOSED PARTS ARE ACCEPTABLY INSULATED FROM THE SUPPLY CIRCUIT.

1. SAFETY INFORMATION

SAFETY INFORMATION

This product has been designed and manufactured according to FDA regulations "title 21, CFR, chapter 1, subchapter J, based on the Radiation Control for Health and Safety Act of 1968", and is classified as class 1 laser product. There is not hazardous invisible laser radiation during operation because invisible laser radiation emitted inside of this product is completely confined in the protective housings.

The label required in this regulation is shown ①.

● **CAUTION**

- DO NOT REMOVE THE PROTECTIVE HOUSING USING SCREWDRIVER.
- USE OF CONTROLS OR ADJUSTMENTS OR PERFORMANCE OF PROCEDURES OTHER THAN THOSE SPECIFIED HEREIN MAY RESULT IN HAZARDOUS RADIATION EXPOSURE.
- IF THIS PRODUCT DEVELOPS TROUBLE, MAKE A CONTACT WITH OUR SERVICEMAN, AND DO NOT USE THE PRODUCT IN A TROUBLED STATE.

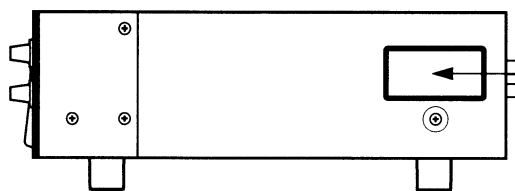

For U.S.A.

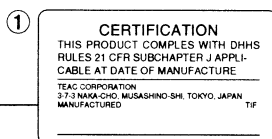

Optical pickup:	Type : OPU24.36
	Manufacturer : Philips Components
	Laser output : 2.5 mW (Play), 35 mW (Record)
	Wavelength : 775~795 nm

● **CAUTION** ● **ACHTUNG** ● **OBSERVERA** ● **ADVARSEL**

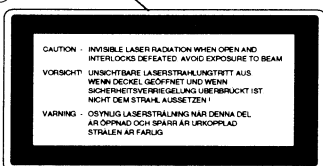
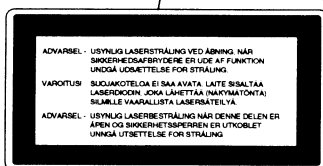
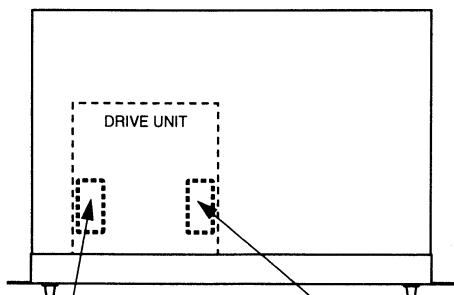
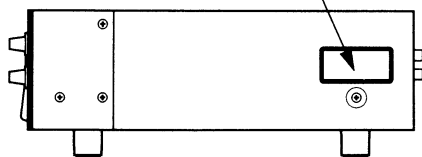
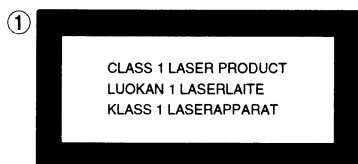

① THIS LABEL IS ATTACHED TO THE PLACE AS ILLUSTRATED TO INFORM THAT THE APPARATUS CONTAINS A LASER COMPONENT.

① DIESE AUFKLEBEMARKE IST AN DEM IN DER ABBILDUNG GEZEIGTEN ORT ANGEBRACHT UM DARAUF HINZUWEISEN, DASS IM INNERN DES GER

① PÅSKRIFTEN SITTER PÅ APPARATEN SOM VISAS SOM UPPMÄNING OM ATT APPARATEN OMFATTAR EN INBYGGD LASERKOMPONENT.

① DETTE MÆRKAT ER ANBRAGT SOM VIST I ILLUSTRATIONEN FOR AT ADVARE BRUGEREN OM AT APPARATET INDEHOLDER EN LASERKOMPONENT.

② DETTE MÆRKAT ER SOM VIST PÅ ILLUSTRATIONEN ANBRAGT PÅ INDERSIDEN AF TOPDÆKSLET FOR AT ADVARE BRUGEREN OM AT YDERLIGERE FREMTRÆNGEN VIL VÆRE FORBUNDET MED FARE FOR AT UDSÆTTE SIG FOR LASERSTRÅLING.

ADVARSEL — BETJENING AF ANDRE KONTROLLER OG REGULATØRER ELLER BENYTTES AF ANDRE FREMGANGSMÅDER END BESKREVET HERI ER FORBUNDET MED FARE FOR UDSÆTTELSE FOR LASERSTRÅLING.

VARING: APPARATEN INNEHÅLLER LASER KOMPONENT MED STRÅLNING ÖVERSTIGANDE KLASS 1.

ADVARSEL: USYNLIG LASERSTRÅLING VED ÅBNING NÅR SIKKERHEDSAFBRYDNERE ER UDE AF FUNKTION. UNDGÅ UDSÆTTELSE FOR STRÅLING

*VAROITUS! SUOJAKOTELOA EI SAA AVATA. LAITE SISÄLTÄÄ LASERDIODIN. JOKA LAIETTAA VAARALLISTA LASERS

ADVARSEL: USYNLIG LASERBESTRÅLING NÅR DENNE DELEN ER ÅPEN OG SIKKERHETSSPERREN ER UTKOBLET UNNGÅ UTSETTELSE FOR STRÅLING.

2. SPECIFICATIONS

仕様

Audio specifications

Recording time : 74 minutes (with 74-minute disc)
 CD type : Playback of CD-DA (Red Book), CD-R and CD-RW
 Recording on CD-R and CD-RW
 Input sampling frequency : 32 kHz - 48 kHz
 Recording sampling frequency : 44.1 kHz
 Recording resolution : 16-bit linear
 Frequency response : 20 Hz to 20,000 Hz (± 0.5 dB playback,
 ± 1 dB recording)
 S/N ratio : >98 dB (playback), >90 dB (recording)
 Dynamic range : >95 dB (playback), >90 dB (recording)
 Total harmonic distortion (1 kHz @ FS - 1.1 dB at recording) :
 $<0.008\%$ (playback), $<0.012\%$ recording)
 Channel separation : >90 dB (playback), >86 dB (recording)
 (1kHz @ FS)
 Wow and flutter : Unmeasurable ($<0.001\%$)

I/O specifications

Analog inputs (balanced XLR-3-31 type) :
 Nominal input level +4dBu (FS=-16 dB)
 Maximum input level +20 dBu
 Input impedance 10 k Ω
 Analog inputs (unbalanced RCA) :
 Nominal input level -10dBV (FS=-16 dB)
 Maximum input level +6 dBV (2Vrms)
 Input impedance 10 k Ω
 Analog outputs (balanced XLR-3-32 type) :
 Nominal output level +4dBu (FS=-16 dBu)
 Maximum output level +20 dBu
 All level measurements made with trimmer set to
 maximum value
 Output impedance 75 Ω
 Trimmers provide up to 12 dB of attenuation
 Analog outputs (unbalanced RCA) :
 Nominal output level -10 dBV
 Maximum output level +6 dBV (2 Vrms)
 Output impedance 200 Ω
 Headphone 1/4-inch stereo jack : 2 x 32 mW into 32 Ω
 Digital output (optical TOSLINK) : IEC60958 format (Type II)
 Digital output (unbalanced RCA) : IEC60958 format (Type II)
 Digital input (balanced XLR-3-31 type) :
 AES3-1992 (Type I) or IEC60958 format (Type II)
 Digital input (unbalanced RCA) :
 AES3-1992 (Type I) or IEC60958 format (Type II)
 Digital input (optical TOSLINK) :
 AES3-1992 (Type I) or IEC60958 format (Type II)
 Parallel I/O port : 15-pin 'D'-sub connector
 REMOTE CONTROL 3.5 mm mini-jack
 For use with supplied RC-RW5000 remote control
 unit only

オーディオ仕様

録音時間 : 74分 (74分ディスクの場合)
 記録メディア : CD-R/CD-RW
 入力サンプリング周波数 : 32~48 kHz
 録音サンプリング周波数 : 44.1 kHz
 録音分解能 : 16ビット、リニア
 周波数特性 : 20 Hz~20 kHz
 (再生時: ± 0.5 dB、記録時: ± 1 dB)
 S/N比 : 98 dB以上 (再生時)
 90 dB以上 (記録時)
 ダイナミック・レンジ : 95 dB以上 (再生時)
 90 dB以上 (記録時)
 歪率 : 0.008%以下 (再生時)
 0.012%以下 (録音時)
 チャンネル・セパレーション (1 kHz @ フルスケール) :
 95 dB以上 (再生時)
 86 dB以上 (記録時)
 ワウ・フラッター : 測定限界以下 (0.001%以下)

入出力仕様

アナログ入力 (XLR-3-31、バランス) :
 規定入力レベル : +4 dBu (フルスケールの16 dB下)
 最大入力レベル : +20 dBu
 入力インピーダンス : 10 k Ω
 アナログ入力 (RCA、アンバランス) :
 規定入力レベル : -10 dBV (フルスケールの16 dB下)
 最大入力レベル : +6 dBV (2 Vrms)
 入力インピーダンス : 10 k Ω
 アナログ出力 (XLR-3-32、バランス) :
 規定出力レベル : +4 dBu (フルスケールの16 dB下)
 最大出力レベル : +20 dBu (トリマー調整可能最大
 レベル)
 出力インピーダンス : 75 Ω
 アッテネート範囲 : 0~-12 dB
 アナログ出力 (RCA、アンバランス) :
 規定出力レベル : -10 dBV (フルスケールの16 dB下)
 最大出力レベル : +6 dBV (2 Vrms)
 出力インピーダンス : 200 Ω
 ヘッドホン (6 ϕ ステレオ・ジャック) :
 2 x 32 mW (32 Ω 時)
 デジタル出力 (オプティカルTOSLINK) :
 IEC60958 Type II
 デジタル出力 (RCA、アンバランス) :
 IEC60958 Type II
 デジタル入力 (XLR-3-31、バランス) :
 AES/EBU (AES3-1992) フォーマット
 デジタル入力 (RCA、アンバランス) :
 IEC60958 Type I/Type II
 デジタル入力 (オプティカルTOSLINK) :
 IEC60958 Type I/Type II
 コントロールI/Oポート : 15ピンDサブ・コネクタ
 REMOTE IN (3.5 mmミニジャック) :
 付属のリモコン専用接続端子

Physical specifications

Voltage requirements :

USA/Canada 120 VAC @ 60 Hz

Europe/UK 230 VAC @ 50 Hz

Australia 240 VAC @ 50 Hz

Power consumption : 24W

Weight : 5.6 kg (12.35 lbs)

Dimensions (w x h x d) : 482 x 104.5 x 310 mm (19 x 4.1 x 12.2 in)

Operating temperature : 5°C to 35°C (41°F to 95°F)

Supplied accessories :

Rack-mounting screw kit

RC-RW5000 wired remote control unit

- In these specifications, 0 dBV is referenced to 1.0 Vrms, and 0 dBu is referenced to 0.775 Vrms.
- Changes to specifications and features may be made without notice or obligation.
- IEC-60958 TYPE I (AES3-1992) is a standard for broadcasting studios (professional). It can not be used for connecting consumer products.
IEC-60958 TypeII (SPDIF) is a standard for consumer products.

その他の仕様

電源 : 100 V AC、50-60 Hz

消費電力 : 24 W

質量 : 5.6 kg

外形寸法 (幅 x 高さ x 奥行) :

482 x 104.5 x 310 mm

動作保証温度 : 5°C ~ 35°C

- 0 dBu = 0.775 Vrms、0 dBV = 1.0 Vrmsで表記しています。
- 仕様、外観などは改善のため予告なく変更することがあります。
- Type I = Broadcasting Studioフォーマット、Type II = Consumerフォーマット(SPDIF)

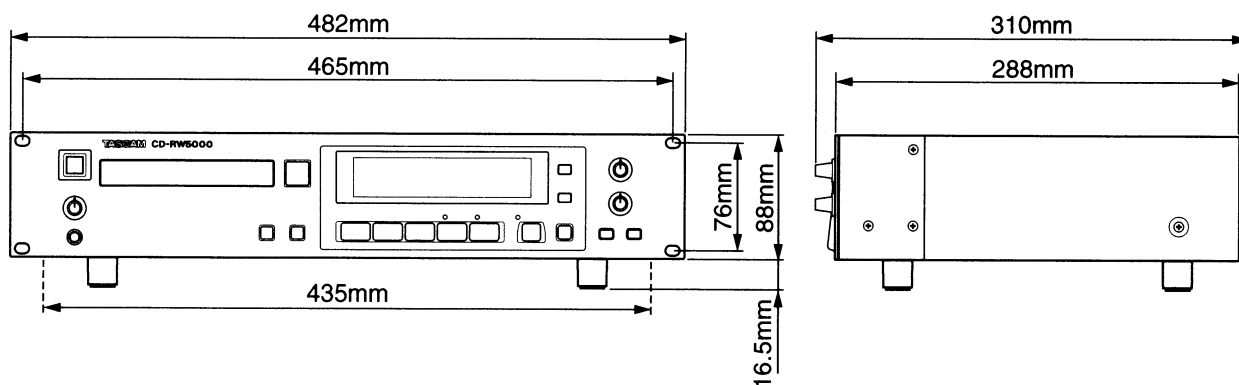

3. TEST MODE

テストモード

3-1 Checking FRONT microprocessor

Switch on the power while holding down the STOP key and PAUSE key.

Press the ◀◀ key before pressing the RECORD key while TASAM is displayed.

After LINE TEST is displayed, check the following 3 items in order.

Press the ▶▶ key to switch to the next item.

1) Checking EEPROM

Operation of the EEPROM mounted on the FRONT PCB can be checked.

EEPROM OK or NG is displayed.

2) Checking FL display

The entire FL display lights → Level meter is displayed.

The above is repeated.

3) Checking key entry of this unit and remote control unit

Letters are displayed according to the key pressed.

(Ex.: STOP key is pressed → STOP is displayed.)

* Switch off the power to exit from the mode above.

3-2 ELAPSED TIME display

Switch on the power while holding down the STOP key and PAUSE key.

Press the ◀◀ key before pressing the ▶▶ key while TASAM is displayed.

When this mode is activated, the elapsed time that the unit has been powered is displayed. (unit: hours)

Press the ◀◀ key to display it in minutes and seconds.

Press the ▶▶ key to display it in hours.

Each press of the DISPLAY key changes the display as follows:
REC time → PLAY time → Elapsed time that the unit has been powered.

These 3 values are updated in the EEPROM every 10 minutes after the power is switched on.

* Switch off the power to exit from the mode above.

3-1. FRONTマイコン動作チェック

STOPキーとPAUSEキーを押しながら電源を投入し、TASAM表示の間に、◀◀を押してからRECORDキーを押します。

LINE TEST表示の後、下記の3項目のチェックが順番に行えます。

項目を切り替えるには、▶▶キーを押します。

1) EEPROMチェック

FRONT PCBに搭載しているEEPROMの動作確認です。
EEPROM OK あるいは NG を表示します。

2) FL表示チェック

全点灯→レベルメーター表示を繰り返します。

3) 本体キー、リモコン・キー入力チェック

押したキーに合わせて文字を表示します。

(例：STOPキーを押す→STOPを表示)

* 上記モードから抜けるには電源を切ってください。

3-2. ELAPSED TIME表示

STOPキーとPAUSEキーを押しながら電源を投入し、TASAM表示の間に、◀◀キーを押してから▶▶キーを押します。

起動時は通電時間を表示します。(単位：時間)

◀◀キーを押すと分・秒までの表示に切り替わります。

▶▶キーで時間表示に戻ります。

DISPLAYキーを押すごとに、REC時間→PLAY時間→通電時間の順に切り替わります。

なお、電源投入後の10分毎に3種のデータがEEPROMに記録されます。

* 上記モードから抜けるには電源を切ってください。

4. EXPLODED VIEW AND PARTS LIST

分解図とパーツリスト

EXPLODED VIEW-1

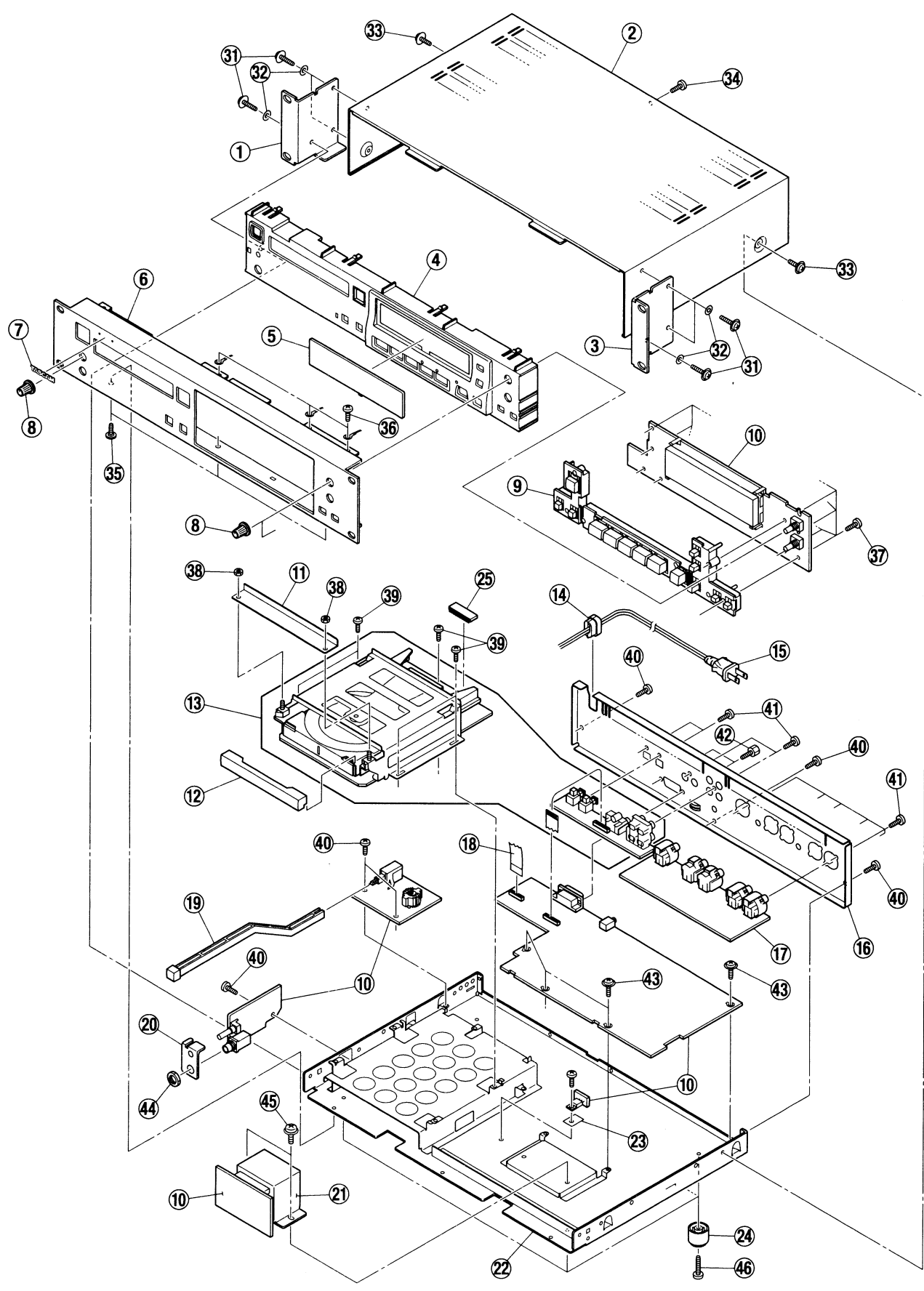

EXPLODED VIEW-1

REF. NO.	PARTS NO.	DESCRIPTION	REMARKS
1- 1	* 9260310900	ANGLE L	
1- 2	* 9260307901	BONNET	
1- 3	* 9260311000	ANGLE R	
1- 4	* 9260308101	ESCUTCHEON	
1- 5	* 9260308700	FL WINDOW	
1- 6	* 9260308000	FRONT PANEL	
1- 7	* 9260271101	BADGE, TASCAM SILVER	
1- 8	* M00002502A	KNOB, NB	
1- 9	9260308202	BUTTON	
1-10	* 9145256001	GATHER PCB A ASS'Y [J, US/C]	
	* 9145256050	GATHER PCB A ASS'Y [K, A, E, UK]	
1-11	* 9260327600	BRACKET, DISK	
1-12	* 9260308600	TRAY PANEL	
1-13	* 9278373300	MECHA ASS'Y	
1-14	△ * 9121000102	BUSHING, #2271 [J, K, A, E]	
	△ * 9121000400	BUSHING, 6N3-4 [US/C]	
1-15	△ * E00423900A	POWER CORD, 3A 250V [K]	
	△ * 9109026112	AC CORD [J]	
	△ * 9109029400	AC CORD, SJT 3P (UL) [US/C]	
	△ * 9109026010	AC CORD [A]	
	△ * 9109025711	AC CORD, CEE CLASS2 [E]	
	△ * 9109027701	AC CORD, WLTH FUSE [UK]	
1-16	* 9260307601	REAR PANEL [J, K, A, E, UK]	
	* 9260308401	REAR PANEL [US/C]	
1-17	* 9145257000	GATHER PCB B ASS'Y	
1-18	* 9107113401	FFC CABLE, 16P 80MM	
1-19	* 9260308800	POWER LINKAGE	
1-20	* 9260302801	PHONE BRACKET	
1-21	△ 9125128001	POWER TRANS, Z80228C	
1-22	* 9260309101	CHASSIS ASS'Y	
1-23	* 9260232900	SHEET, RADIATOR D	
1-24	5504676000	FOOT	
1-25	* 9167055700	EPROM ASSY (PHILIPS MECHA)	
1-31	* 9783053012	SCREW, CAP-S M3X12 (BLK)	
1-32	* 9294209100	WASHER, FIBER 7. 3X3. 2X0. 5T	
1-33	* 9783053006	SCREW, CAP-S M3X6 (BLK)	
1-34	* 9783593008	SCREW, C-TITE M3X8 (NI-BLK)	
1-35	* 9783393006	SCREW, JOGGLING M3X6	
1-36	* 9783213006	SCREW, BTT-B M3X6	
1-37	* 9783603010	SCREW, BTT-P M3X10	
1-38	* 9781823000	NUT, M3	
1-39	* 9783213008	SCREW, BTT-B M3X8	
1-40	* 9783243008	SCREW, BTT-B M3X8 (BLK)	
1-41	* 9783613008	SCREW, BTT-P M3X8 (BLK)	
1-42	* 9783802612	SCREW, LOCK M2. 6X12	
1-43	* 9783103008	SCREW, CAP-S M3X8	
1-44	* 9781801200	NUT, M12	
1-45	* 9783294008	SCREW, BTT-SSB M4X8	
1-46	* 9783204018	SCREW, BTT-S M4X18	

5. PC BOARDS AND PARTS LIST

基板図とパーツリスト

HEAD PHONE PCB

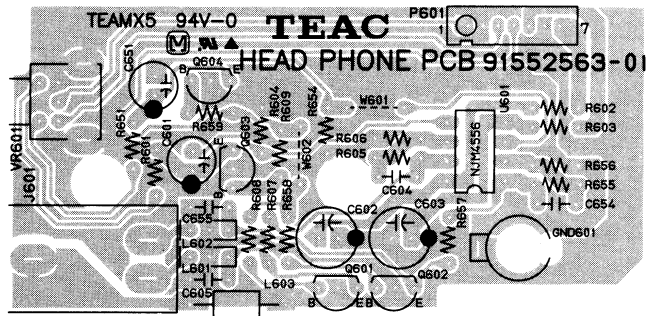

TRANS PCB

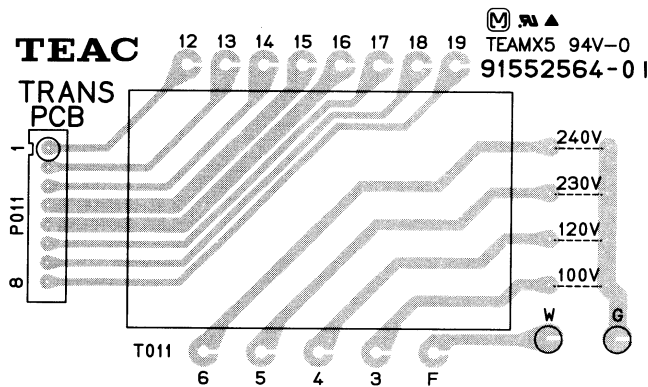

POWER SW PCB

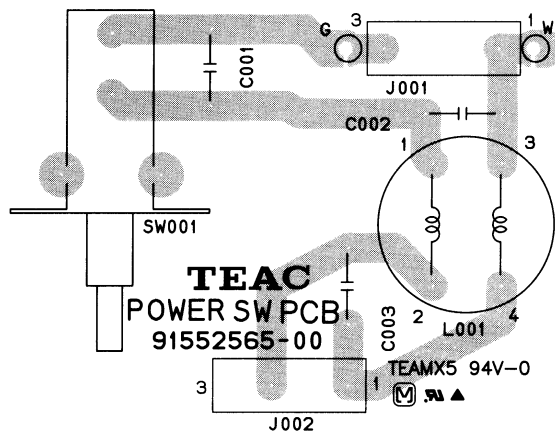

MAIN PCB

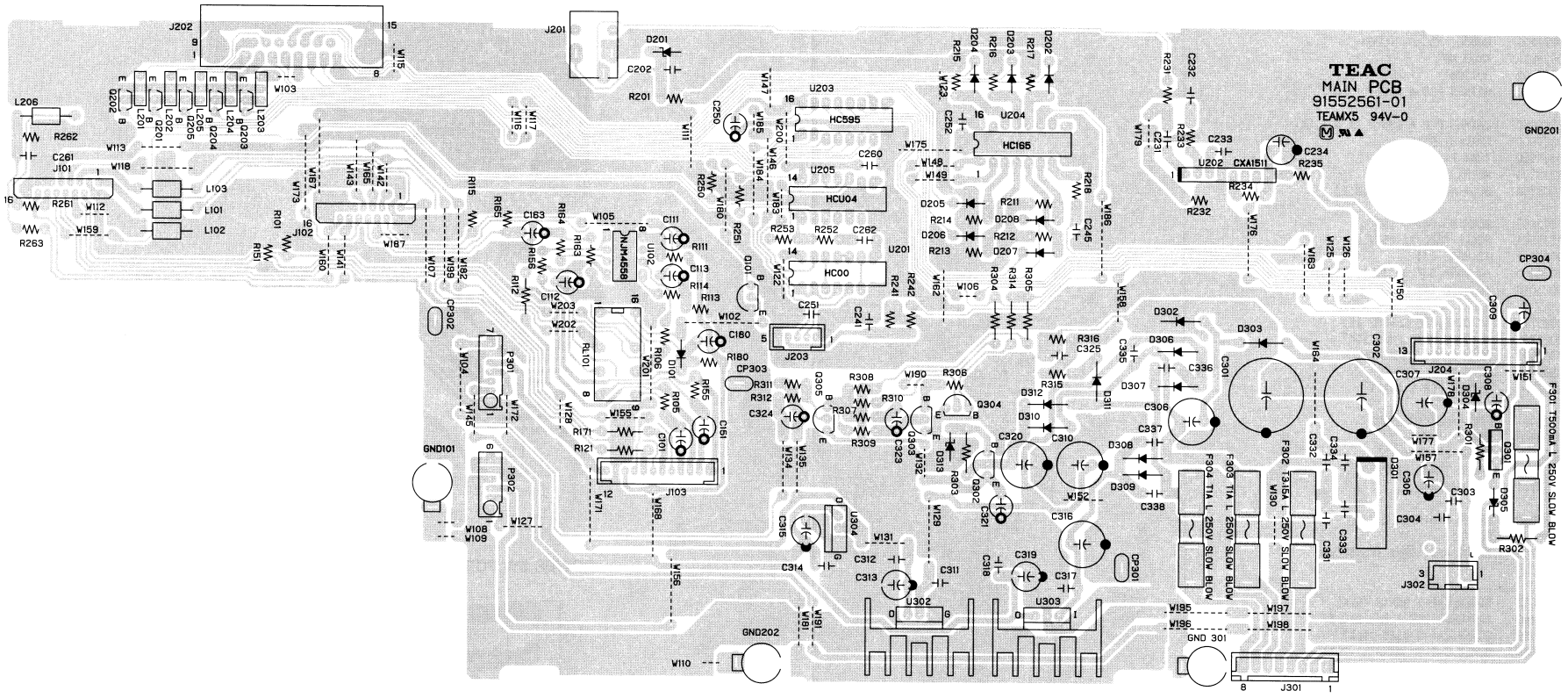

FRONT PCB

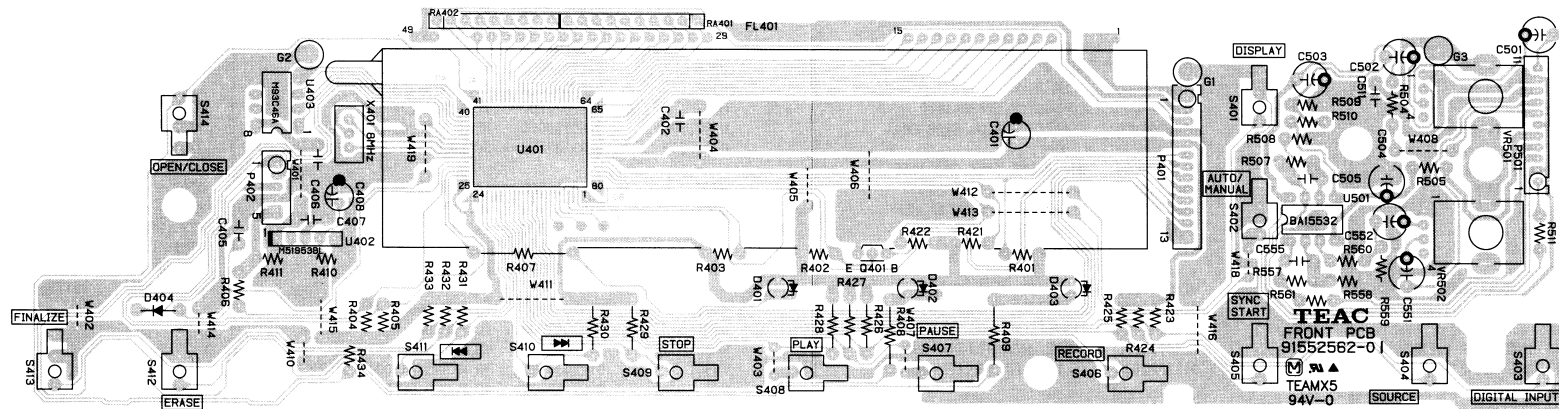

LA-RW5000 PCB

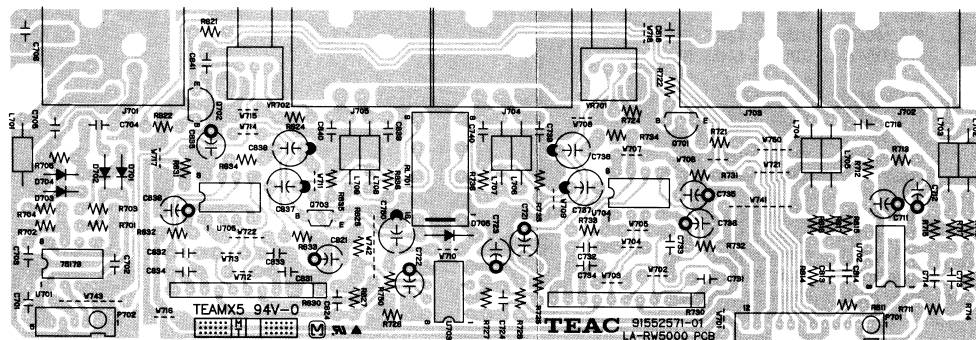

GATHER PCB A ASSY

REF. NO.	PARTS NO.	DESCRIPTION
	*9145256001	GATHER PCB A ASSY [J, US/C]
	*9145256050	GATHER PCB A ASSY [K, A, E, UK]
	*9155256001	GATHER PCB A MAIN PCB FRONT PCB
		HEAD PHONE PCB TRANS PCB POWER SW PCB RG5V PCB
CP301-303	5730018100	CLIP, COATING CP-1S
C001-003	△ 9120000500	SPARK KILLER, 0.0047U/250V
C301, 302	△ 9117302000	C, ELEC 3300M 16V
C306, 307	△ 9117217000	C, ELEC 220M-KC 63V
C308	△ 9117141020	C, ELEC 10UF/50V TP
C310, 316	△ 9117260000	C, ELEC 1000UF/35V
C311, 317	△ 9115818120	C, CERAMIC 0.01UF/50V K
C320	△ 9117245000	C, ELEC 470M 35V
C331-338	△ 9115827020	C, CERAMIC 0.1UF 50V J
D101	9165020550	DIODE, LT 1N4003 TP 0.6MM
D201	9166045351	Z, DIODE RD2.7ESAB2
D202-208	9165022150	DIODE, TP 1SS133T
D301	△ 9165025700	DIODE, RS-405L
D301	9290002000	SILICON TUBE M 3X2X15
D302, 303	△ 9165020550	DIODE, LT 1N4003 TP 0.6MM
D304	△ 9166047752	Z, DIODE RD27ES-TP B3
D305	9166046250	Z DIODE, RD 6.2ESB1
D306-309	△ 9165020550	DIODE, LT 1N4003 TP 0.6MM
D310, 312	△ 9165026550	DIODE, 11EQS06
D311	△ 9165020550	DIODE, LT 1N4003 TP 0.6MM
D313	△ 9166046150	Z, DIODE RD5.6ES-TP B1
D401	9174019300	LED, SLR-342MG-3F
D402	9174015900	LED (AMBER), SLR-342DU-3F-M
D403	9174015800	LED (RED), SLR-342VR-3F
D401-403	9260303400	HOLDER, LED 18.5MM
D404	9165022150	DIODE, TP 1SS133T
FL401	9174025200	FL DISPLAY, BJ642GK
FL401	9260308500	ANGLE, FL
F301	△ 9150060000	FUSE, 0.5A 250V 51T0500H [K, A, E, UK]
	△ 9150061000	FUSE, 0.5A 250V 51S0500H [J, US/C]
F302	△ 9150038000	FUSE, T-LAG 3.15A 250V T [J, US/C]
	△ 9150053000	FUSE, T-LAG 50T032H [K, A, E, UK]
F303, 304	△ 9150045000	FUSE, T-LAG 1A 250V EUR [K, A, E, UK]
	△ 9150046000	FUSE, T-LAG 1A 250V [J, US/C]
F301-304	9150018000	HOLDER, FUSE 2-N1152

GATHER PCB A ASSY

REF. NO.	PARTS NO.	DESCRIPTION
GND101	9229087200	EARTH PLATE, B (GND-7)
GND201	9229087200	EARTH PLATE, B (GND-7)
GND202	9229087200	EARTH PLATE, B (GND-7)
GND301	9229087200	EARTH PLATE, B (GND-7)
GND601	9229087200	EARTH PLATE, B (GND-7)
G1, 2	9107113100	GND WIRE
G3	9107113100	GND WIRE
J001, 002	△ 9144450000	PLUG, B3P4-VB-2
J101, 102	9144448000	CONNECTOR, 52030-1610
J103	9143240000	CONNECTOR PLUG, B12B-PH-K
J201	9144176000	MINIATURE JACK, CPJ-3055
J202	9144449001	D-SUB 205A-15FSTBBW3
J202	9260306600	D-SUB 25P SPRING WASHER
J202	9260306700	D-SUB 25P SPRING
J203	9143233000	PLUG, 5P B5P-PH-K
J204	9143241000	PLUG, 13P B13B-PH-H
J301	9143162000	CONNECTOR PLUG8P B8B-XH-A
J302	9143157000	CONNECTOR PLUG 3P B3B-XHA
J601	9144432000	PHONE JACK, HTJ-064-09D
L001	9122020500	AC LINE FILTER, LFH-601U
L101-103	9122020450	BEAD, WBRN 3.5X6X0.8 TP
L201-205	9122020620	FILTER, EXCEMT103BT TP
L206	9122020450	BEAD, WBRN 3.5X6X0.8 TP
L601, 602	9122020620	FILTER, EXCEMT103BT TP
L603	9122020450	BEAD, WBRN 3.5X6X0.8 TP
P011	9107112501	8P TRANS WIRE
P301	9107112400	7P POWER2 WIRE
P302	9107112300	6P POWER1 WIRE
P401	9107112600	13P FRONT1 WIRE 300MM
P402	9107112701	5P FRONT2 WIRE
P501	9107112801	9P FRONT3 WIRE
P601	9107112901	7P PHONE WIRE
P901	9107116900	3P RG5V WIRE
Q101	9163310420	DTR, DTC 124ES TP
Q201-205	9163310420	DTR, DTC 124ES TP
Q301	△ 9163203400	TR, 2SB631F
Q302	△ 9163309420	TR, 2SC1815GR (TP)
Q303, 304	9163309420	TR, 2SC1815GR (TP)
Q305	9163009920	TR, 2SA1015GR (TP)
Q401	9163310420	DTR, DTC 124ES TP
Q601-604	9163310620	TR, TP 2SC-2878A
RA401	9111285000	R, ARRAY 100KX9
RA402	9111284000	R, ARRAY 100KX8
RL101	9138002100	RELAY, RSB-12-S
SW001	△ 9135039200	POWER SW, SDDL1077U

GATHER PCB A ASSY

REF. NO.	PARTS NO.	DESCRIPTION
S401-414	9136002720	SW, TACT SKHVPE3520
U102	9167008100	IC, NJM4558D (8P)
U201	9167029400	IC, TC74HC00AP (14P)
U202	9167028700	IC, CXA1511L (8P)
U203	9167029100	IC, TC74HC595AP (16P)
U204	9167044400	IC, SN74HC165N (16P)
U205	9167036700	IC, TC74HCU04AP
U302	△ 9167035800	IC, NJM7912FA (3P)
U303	△ 9167026700	IC, NJM7812FA (3P)
U302, 303	9260259000	HEAT SINK, CS-B2202-02317
U302, 303	9783243008	SCREW, BTT-B M3X8 (BLK)
U304	△ 9167014300	IC, NJM7908FA (3P)
U401	9167044600	IC, CXP82940 (80P)
U402	9167036000	IC, M51953BL (5P)
U403	9167038801	IC, 93LC46 DIP (8P)
U501	9167044900	IC, BA15532 (8P)
U601	9167044500	IC, NJM4556D (8P)
U901	△ 9167042900	IC, PQ05RF2
VR501, 502	9172035800	VR, RK11K1140017 20KA TK
VR601	9172034500	VR RK09K12AZ003 20KAX2
W. G	9107113001	4P POWER SW WIRE
X401	9173011000	OSC, CST8.00MTW-1

GATHER PCB B ASSY

REF. NO.	PARTS NO.	DESCRIPTION
	*9145257000	GATHER PCB B ASSY
	*9155257001	GATHER PCB B LA-RW5000 PCB
D701-704	9165022150	DIODE, TP 1SS133T
D705	9165020550	DIODE, LT 1N4003 TP 0.6MM
J701-703	9144456000	CONNECTOR, NC3FAH2-0
J704, 705	9144198001	XLR PLUG, NC3MAH
L701-709	9122020450	BEAD, WBRN 3.5X6X0.8 TP
P701	9107113200	12P OPTION1 WIRE
P702	9107113300	5P OPTION2 WIRE
Q701, 702	9163310620	TR, TP 2SC-2878A
Q703	9163310420	DTR, DTC 124ES TP
RL701	9138002100	RELAY, RSB-12-S
R730, 830	9111147000	R, ARRAY EXBF11L668FP
U701	9167038600	IC, SN75179
U702-705	9167044900	IC, BA15532 (8P)
VR701, 702	9172035900	VR, RK09K1110873 20KB

6. INCLUDED ACCESSORIES

付属品

INCLUDED ACCESSORIES

REF. NO.	PARTS NO.	DESCRIPTION	REMARKS
	*9101012200	OWNER'S MANUAL, JAPANESE [J]	
	*9101012300	OWNER'S MANUAL, ENGLISH [EXCEPT J]	
	*E00505800A	REMOTE CONTROL UNIT, RC-RW5000	
	*9260283901	INSTALLATION SCREW KIT	

CD-RW5000

TASCAM TEAC Professional Division

ティアック株式会社 電子機器事業部 ☎ (0422) 52-5072 〒180-8550 東京都武蔵野市中町3-7-3
タスカム・ティビジョン

お問い合わせ、ご相談

サービスに関するお問い合わせは、
最寄りの営業所などへご連絡く
ださい。
営業所にはサービス・センター
が併設されています。

タスカム営業技術	☎ (0422) 52-5106	〒180-8550 東京都武蔵野市中町3-7-3
札幌営業所	☎ (011) 521-4101(代)	〒064-0807 札幌市中央区南7条西2-2
仙台営業所	☎ (022) 227-1501(代)	〒980-0811 仙台市青葉区1番町2-5-5
新潟サービス	☎ (025) 245-0103	〒950-0865 新潟県新潟市元馬越1-4-11
大宮サービス	☎ (048) 642-4551	〒331-0052 大宮市三橋2-846
サービス2課	☎ (0422) 52-5107	〒180-8550 東京都武蔵野市中町3-7-3
千葉サービス	☎ (043) 255-1281	〒260-0042 千葉市中央区椿森1-21-13
神奈川サービス	☎ (0427) 46-6850	〒228-0803 相模原市相模大野7-14-9
静岡サービス	☎ (054) 238-2431	〒422-8034 静岡市高松1-12-1
名古屋営業所	☎ (052) 702-3100(代)	〒465-0025 名古屋市名東区上社5-406
京都サービス	☎ (075) 871-8730	〒616-8224 京都市右京区常盤窪町19
大阪サービス	☎ (06) 6384-5365(代)	〒564-0062 吹田市垂水町3-34-10
兵庫サービス	☎ (0727) 55-1002	〒666-0004 兵庫県川西市萩原1-11-29
岡山サービス	☎ (0862) 25-8601	〒700-0945 岡山市新保1142-6
広島営業所	☎ (082) 294-4751(代)	〒730-0846 広島市中区西川口町13-19
福岡営業所	☎ (092) 431-5781(代)	〒812-0008 福岡市博多区東光2-2-24
福岡サービス	☎ (092) 936-5672	〒811-2202 福岡県粕屋郡志免町志免1041
タスカム東京営業所	☎ (03) 3592-2051(代)	〒100-0014 東京都千代田区永田町2-10-7
東京サービス	☎ (03) 3592-1827	〒100-0014 東京都千代田区永田町2-10-7
タスカム大阪営業所	☎ (06) 384-5702(代)	〒564-0062 吹田市垂水町3-34-10

TEAC CORPORATION	3-7-3, Nakacho, Musashino-shi, Tokyo 180-8550, Japan	Phone: (0422) 52-5082
TEAC AMERICA, INC.	7733 Telegraph Road, Montebello, California 90640	Phone: (213) 726-0303
TEAC CANADA LTD.	5939 Wallace Street, Mississauga, Ontario L4Z 1Z8, Canada	Phone: 905-890-8008
TEAC MEXICO, S.A. De C.V.	Privada De Corina, No.18, Colonia Del Carmen Coyoacan, Mexico DF 04100	Phone: 5-658-1943
TEAC UK LIMITED	5 Marlin House, Marlin Meadow, The Croxley Centre, Watford, Herts. WD1 8YA, U.K.	Phone: 01923-819699
TEAC DEUTSCHLAND GmbH	Bahnstrasse 12, 65205 Wiesbaden-Erbenheim, Germany	Phone: 0611-71580
TEAC FRANCE S. A.	17 Rue Alexis-de-Tocqueville, CE 005 92182 Antony Cedex, France	Phone: 01.42.37.01.02
TEAC BELGIUM NV/SA	P.A. TEAC Nederland BV, Perkinsbaan 11a, 3439 ND Nieuwegein, Netherlands	Phone: 0031-30-6048115
TEAC NEDERLAND BV	Perkinsbaan 11a, 3439 ND Nieuwegein, Netherlands	Phone: 030-6030229
TEAC AUSTRALIA PTY., LTD. A.C.N. 005 408 462	106 Bay Street, Port Melbourne, Victoria 3207, Australia	Phone: (03) 9644-2442
TEAC ITALIANA S.p.A.	Via C. Cantù 11, 20092 Cinisello Balsamo, Milano, Italy	Phone: 02-66010500

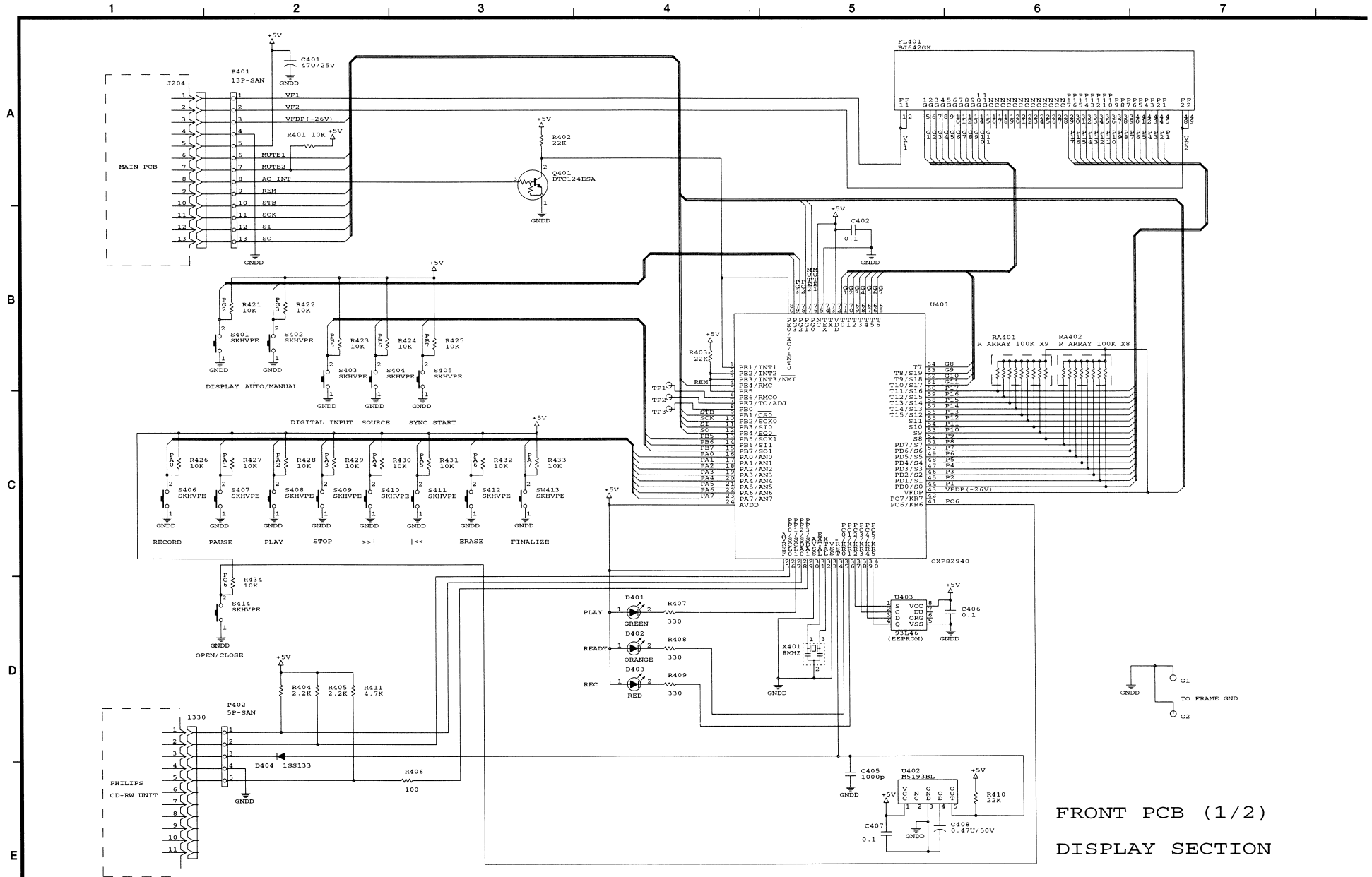

FRONT PCB (1/2)
DISPLAY SECTION

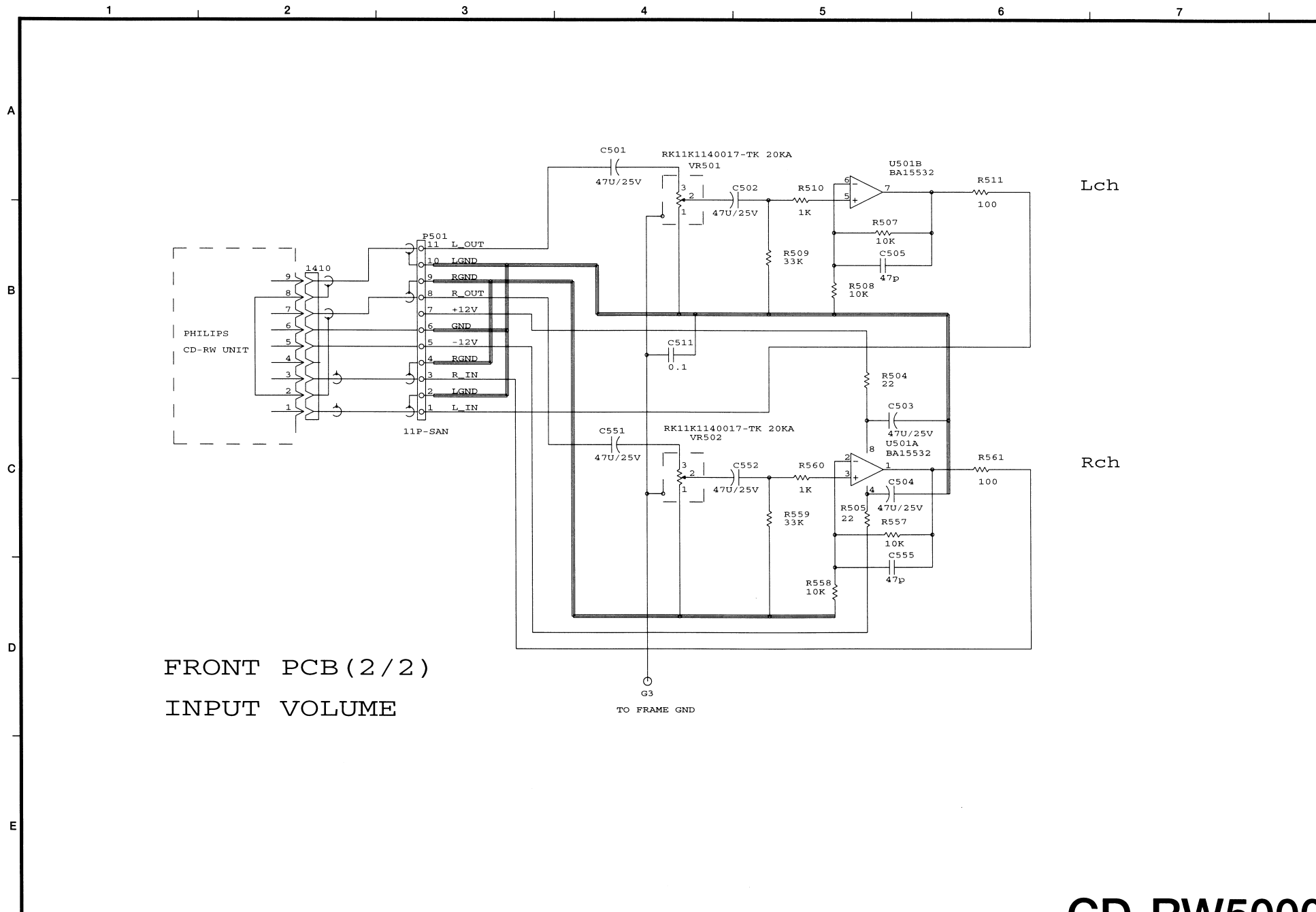

FRONT PCB (2/2)
INPUT VOLUME

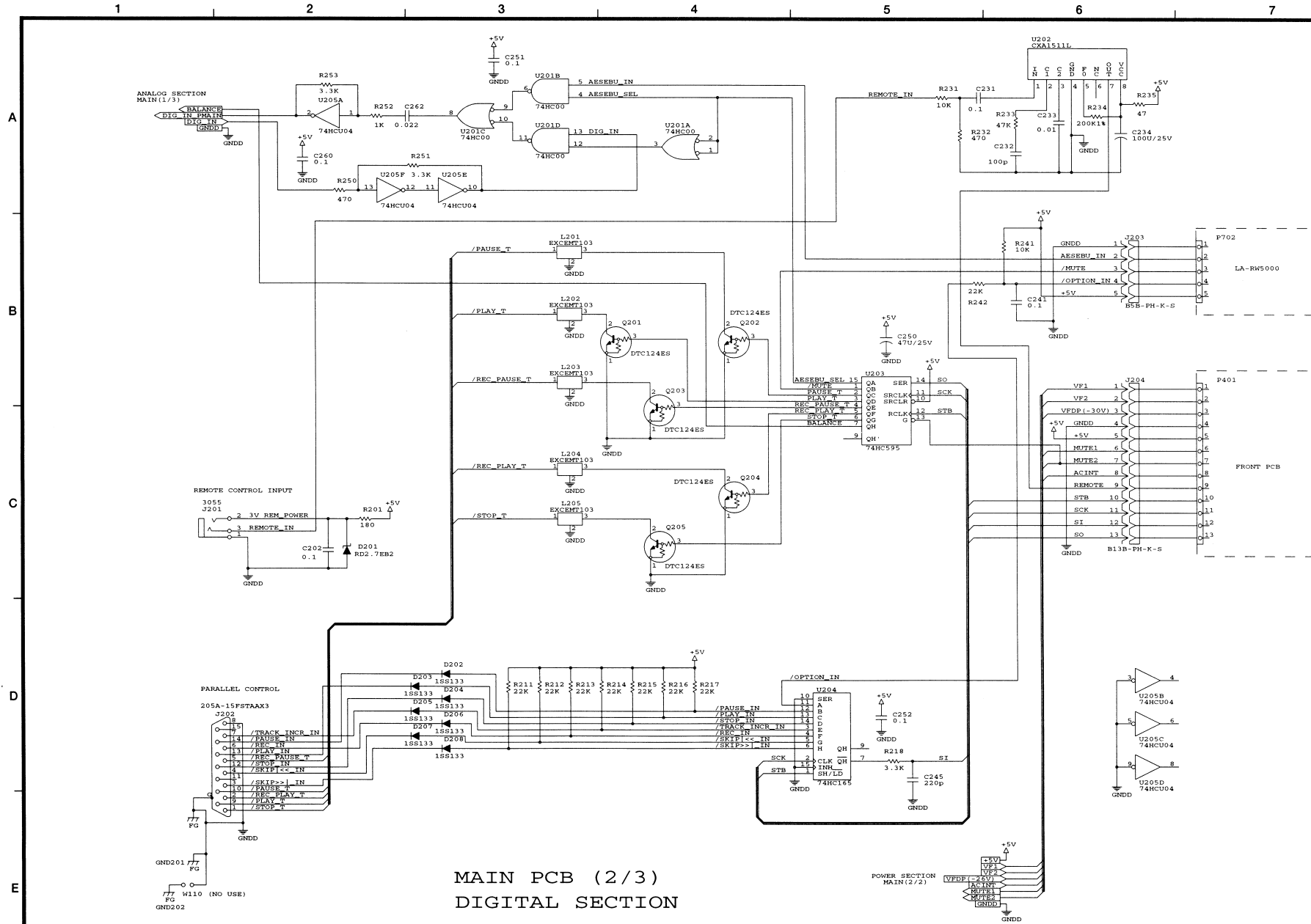

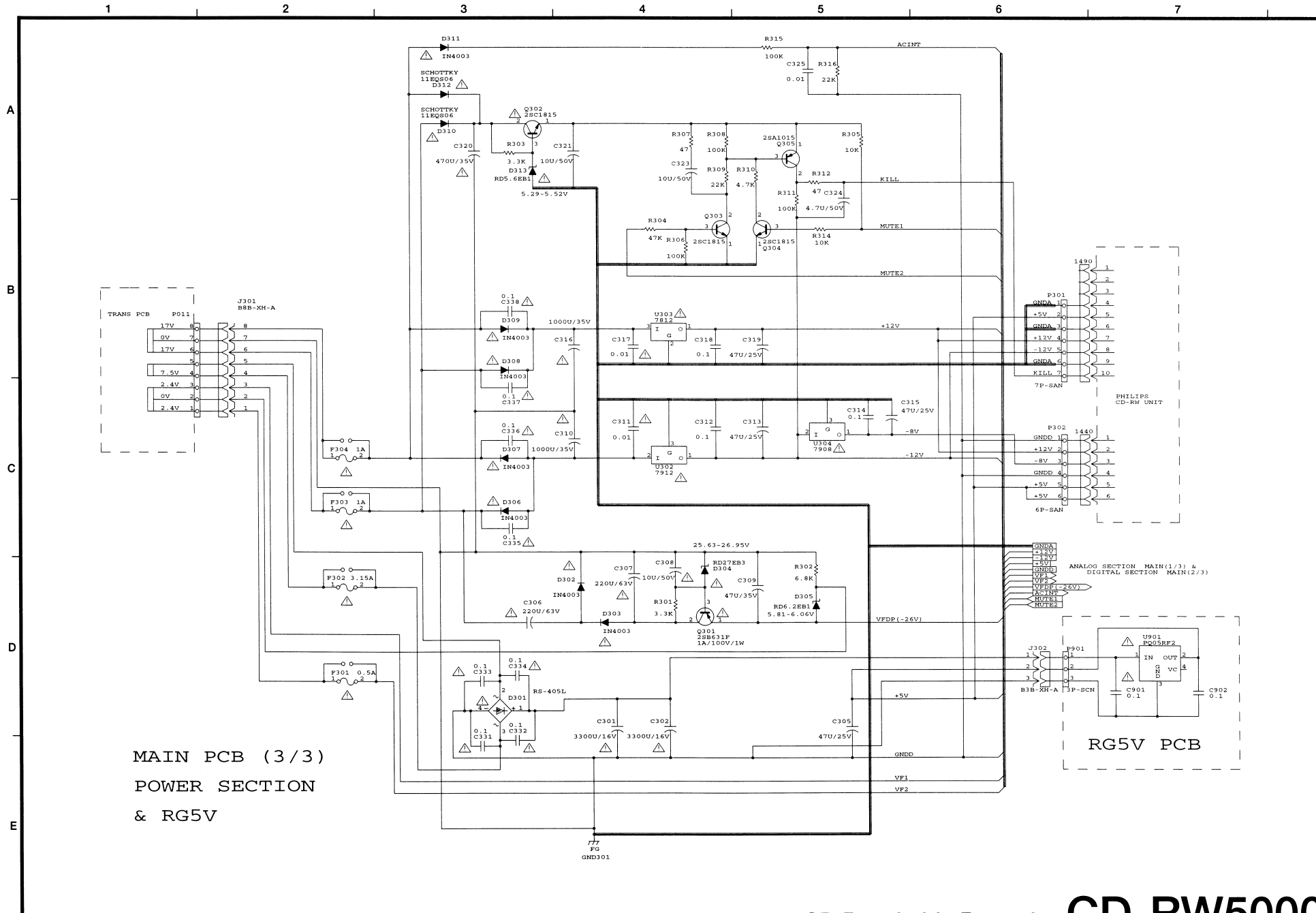

MAIN PCB (3/3)
POWER SECTION
& RG5V

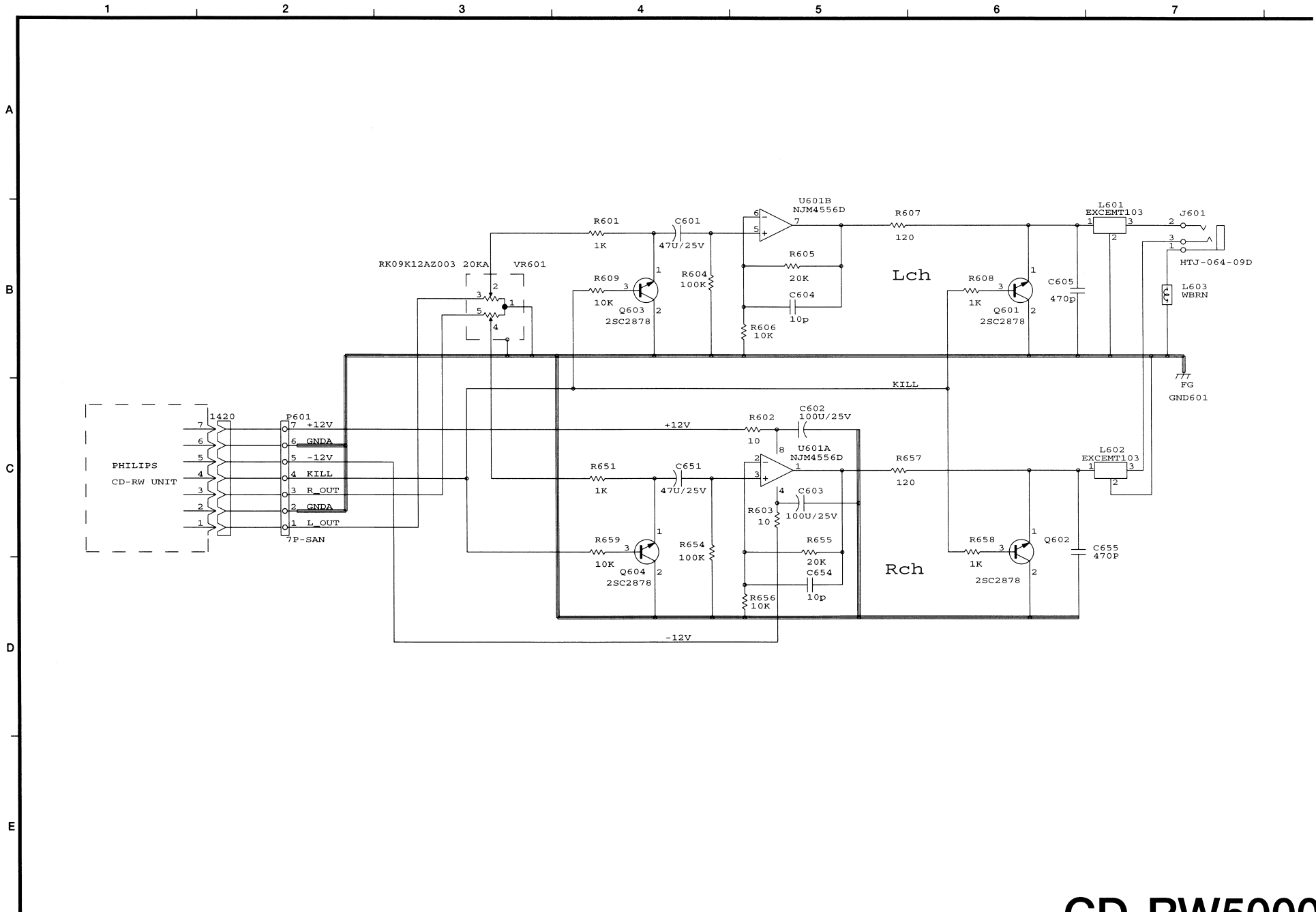

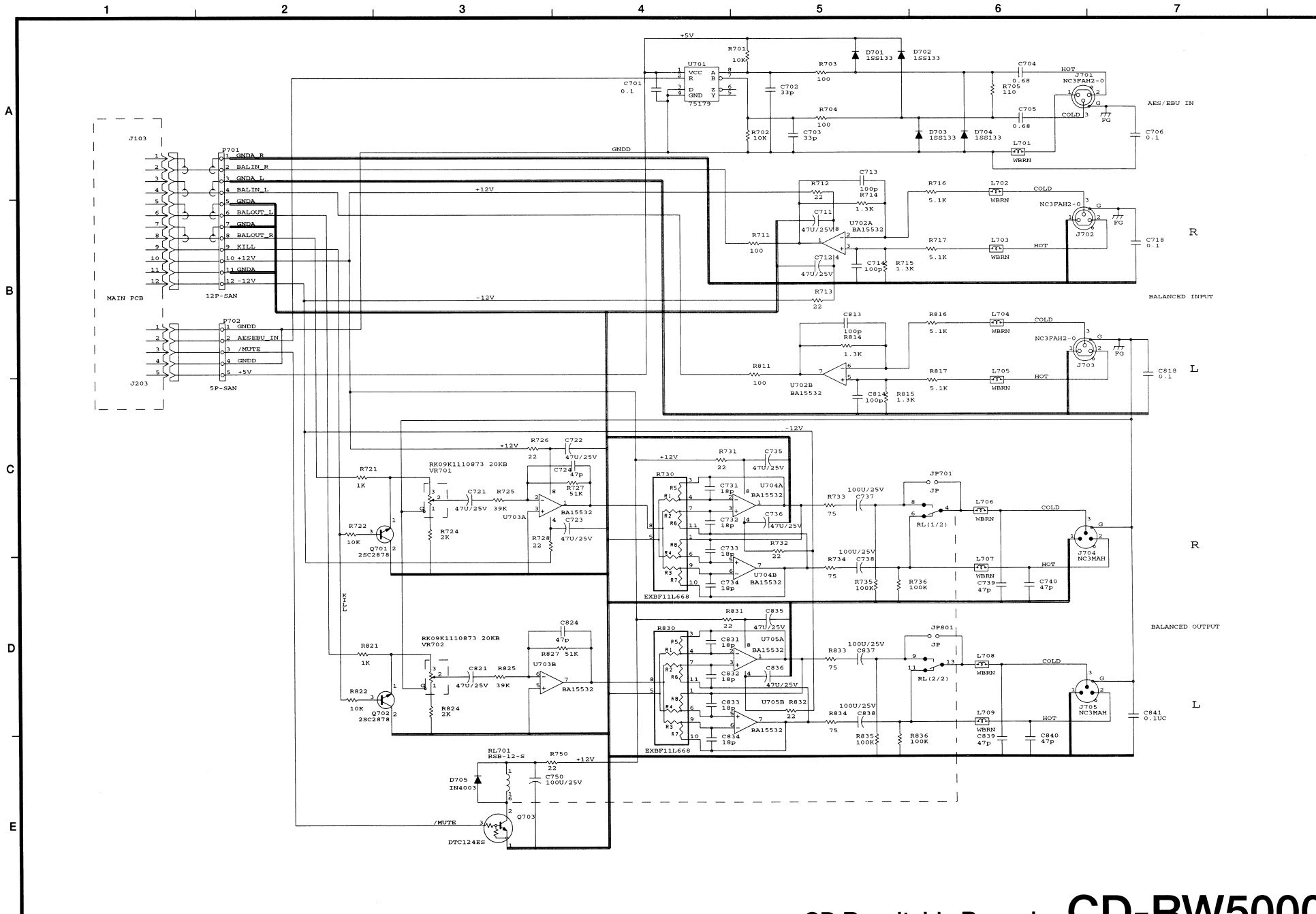

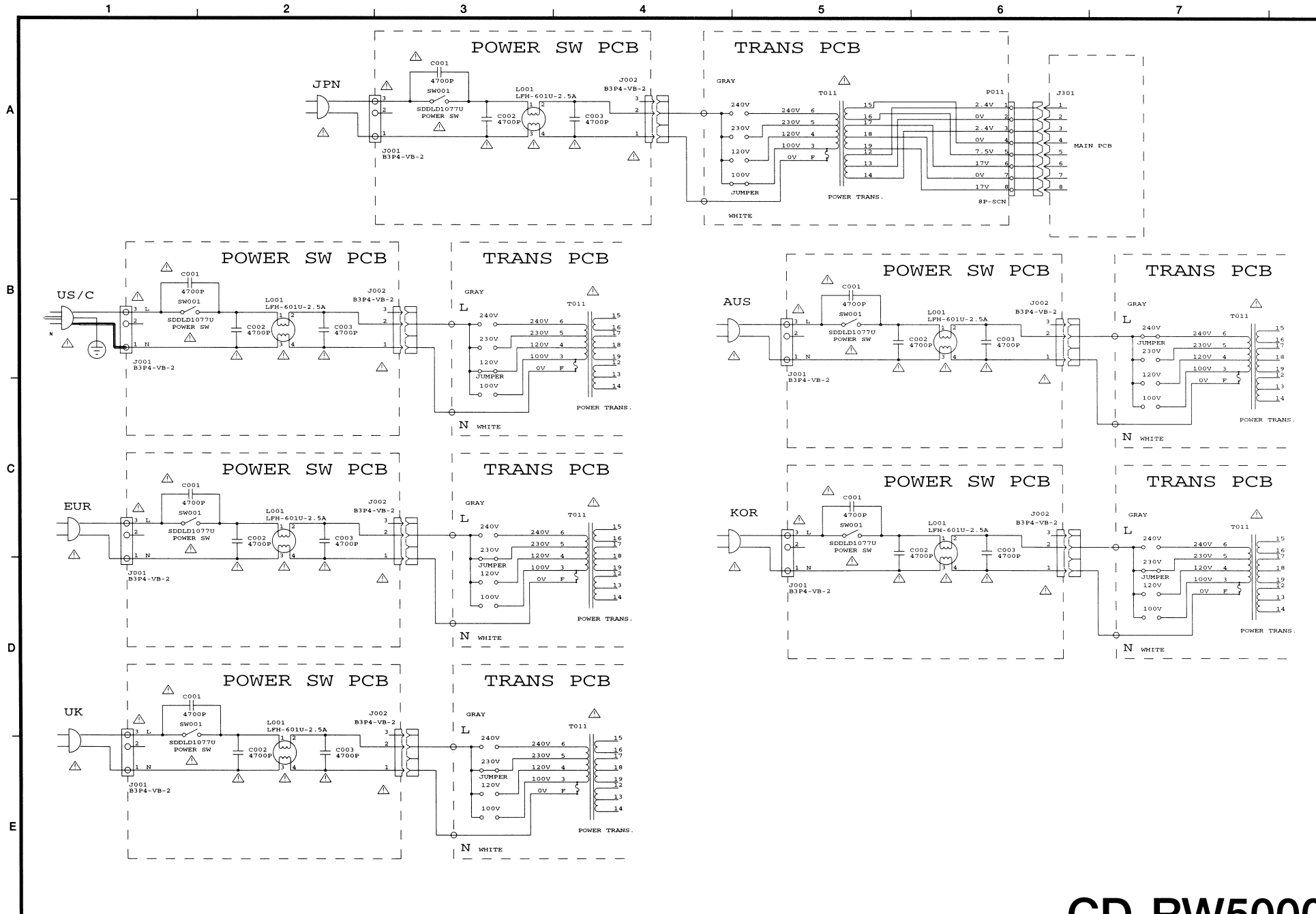

CD-RW5000 Remote Control Code

MODEL: RC-RW5000

KEY No.	Function	DATA	KEY No.	Function	DATA
K1	STOP	0	K33		40
K2	PLAY	1	K34		41
K3	PAUSE	2	K35		42
K4		3	K36	0	43
K5	RECORD	4	K37		44
K6		5	K38		45
K7		6	K39		46
K8		7	K40	DISPLAY	47
K9		8	K41	1	48
K10		9	K42	2	49
K11		A	K43	3	4A
K12	SEARCH REW <<	B	K44		4B
K13	SEARCH FAST	C	K45		4C
K14	SEARCH FWD >>	D	K46	4	4D
K15		E	K47	5	4E
K16		F	K48	6	4F
K17	SKIP REW <<	10	K49		50
K18		11	K50	PGM	51
K19	SKIP FWD >>	12	K51	7	52
K20		13	K52	8	53
K21		14	K53	9	54
K22		15	K54		55
K23		16	K55	REPEAT	56
K24		17	K56		57
K25		18	K57		58
K26	FINALIZE	19	K58		59
K27	ERASE	1A	K59		5A
K28	SYNC START	1B	K60		5B
K29	AUTO/MANUAL	1C	K61		5C
K30	TRACK INCR	1D	K62		5D
K31		1E	K63		5E
K32		1F	K64	OPEN/CLOSE	5F

NEC format Custom code = 00FF h

JACK: 3.5 STEREO PHONE JACK

TIP :3V power supply for remote controller

RING :control signal

DATA SHEET

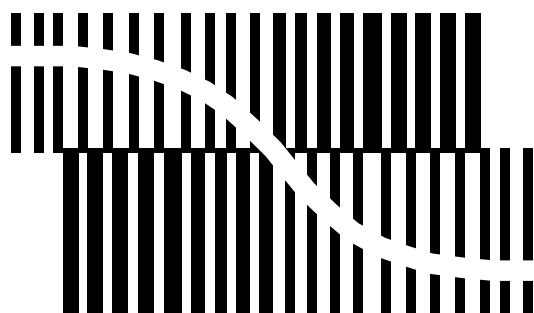

BITSTREAM CONVERSION

TDA1305T

Stereo 1fs data input up-sampling
filter with bitstream continuous dual
DAC (BCC-DAC2)

Preliminary specification
Supersedes data of September 1994
File under Integrated Circuits, IC01

1995 Dec 08

Stereo 1fs data input up-sampling filter with bitstream continuous dual DAC (BCC-DAC2)

TDA1305T

FEATURES

- Easy application
- 16f_s Finite-duration Impulse-Response (FIR) filter incorporated
- Selectable system clock (f_{sys}) 256f_s or 384f_s
- I²S-bus serial input format (at f_{sys} = 256f_s) or LSB fixed 16, 18 or 20 bits serial input mode (at f_{sys} = 384f_s)
- Slave-mode clock system
- Cascaded 4-stage digital filter incorporating 2-stage FIR filter, linear interpolator and sample-and-hold
- Smoothed transitions before and after muting (soft mute)
- Digital de-emphasis filter for three sampling rates of 32 kHz, 44.1 kHz and 48 kHz
- 12 dB attenuation via the attenuation input control
- Double speed mode
- 2nd order noise shaper
- 96 (f_{sys} = 384f_s) or 128 (f_{sys} = 256f_s) times oversampling in normal speed mode
- 48 (f_{sys} = 384f_s) or 64 (f_{sys} = 256f_s) times oversampling in double speed mode
- Bitstream continuous calibration concept
- Small outline SO28 package
- Voltage output 1.5 V (RMS) at line drive level
- Low total harmonic distortion
- No zero crossing distortion
- Inherently monotonic
- No analog post filtering required
- Superior signal-to-noise ratio
- Wide dynamic range (18-bit)
- Single rail supply (3.4 to 5.5 V).

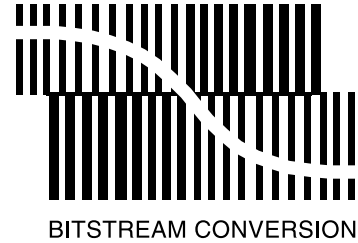

bitstream converter for low signals while large signals are generated using the dynamic continuous calibration technique, thus resulting in low power consumption, small chip size and easy application.

The TDA1305T is a dual CMOS DAC with up-sampling filter and noise shaper. The combination of high oversampling up to 16f_s, 2nd order noise shaping and continuous calibration conversion ensures that only simple 1st order analog post filtering is required.

The TDA1305T supports the I²S-bus data input mode with word lengths of up to 20 bits (at f_{sys} = 256f_s) and the LSB fixed serial data input format with word lengths of 16, 18 and 20 bits (at f_{sys} = 384f_s). Four cascaded FIR filters increase the oversampling rate to 16 times. A sample-and-hold function increases the oversampling rate to 96 times (f_{sys} = 384f_s) or 128 times (f_{sys} = 256f_s). A 2nd order noise shaper converts this oversampled data to a bitstream for the 5-bit DACs.

The DACs are of the continuous calibration type and incorporate a special data coding. This ensures an extremely high signal-to-noise ratio, superior dynamic range and immunity to process variation and component ageing.

Two on-board operational amplifiers convert the digital-to-analog current to an output voltage. Externally connected capacitors perform the required 1st order filtering so that no further post filtering is required.

The unique combination of bitstream and continuous calibration techniques, together with a high degree of analog and digital integration, results in a single filter-DAC with 18-bit dynamic range, high linearity and simple low cost application.

GENERAL DESCRIPTION

The TDA1305T is a new generation of filter-DAC which features a unique combination of bitstream and continuous calibration techniques. The converter functions as a

ORDERING INFORMATION

TYPE NUMBER	PACKAGE		
	NAME	DESCRIPTION	VERSION
TDA1305T	SO28	plastic small outline package; 28 leads; body width 7.5 mm	SOT136-1

Stereo 1fs data input up-sampling filter with
bitstream continuous dual DAC (BCC-DAC2)

TDA1305T

QUICK REFERENCE DATA

SYMBOL	PARAMETER	CONDITIONS	MIN.	TYP.	MAX.	UNIT
V _{DDD}	digital supply voltage	note 1	3.4	5.0	5.5	V
V _{DDA}	analog supply voltage	note 1	3.4	5.0	5.5	V
V _{DDO}	operational amplifier supply voltage	note 1	3.4	5.0	5.5	V
I _{DDD}	digital supply current	V _{DDD} = 5 V; at code 00000H	–	30	–	mA
I _{DDA}	analog supply current	V _{DDA} = 5 V; at code 00000H	–	5.5	8	mA
I _{DDO}	operating amplifier supply current	V _{DDO} = 5 V; at code 00000H	–	6.5	9	mA
V _{FS(rms)}	full-scale output voltage (RMS value)	V _{DDD} = V _{DDA} = V _{DDO} = 5 V	1.425	1.5	1.575	V
(THD + N)/S	total harmonic distortion plus noise-to-signal ratio	at 0 dB signal level	–	–90	–81	dB
			–	0.003	0.009	%
		at –60 dB signal level	–	–44	–40	dB
			–	0.63	0.1	%
at –60 dB signal level; A-weighted	–	–46	–	dB		
	–	0.5	–	%		
S/N	signal-to-noise ratio at bipolar zero	A-weighting; at code 00000H	100	108	–	dB
BR _{ns}	input bit rate at data input	f _s = 48 kHz; normal speed	–	–	3.072	Mbits
BR _{ds}	input bit rate at data input	f _s = 48 kHz; double speed	–	–	6.144	Mbits
f _{sys}	system clock frequency		6.4	–	18.432	MHz
TC _{FS}	full scale temperature coefficient at analog outputs (VOL and VOR)		–	±100 × 10 ^{–6}	–	
T _{amb}	operating ambient temperature		–30	–	+85	°C

Note

1. All V_{DD} and V_{SS} pins must be connected to the same supply.

Stereo 1fs data input up-sampling filter with bitstream continuous dual DAC (BCC-DAC2)

TDA1305T

BLOCK DIAGRAM

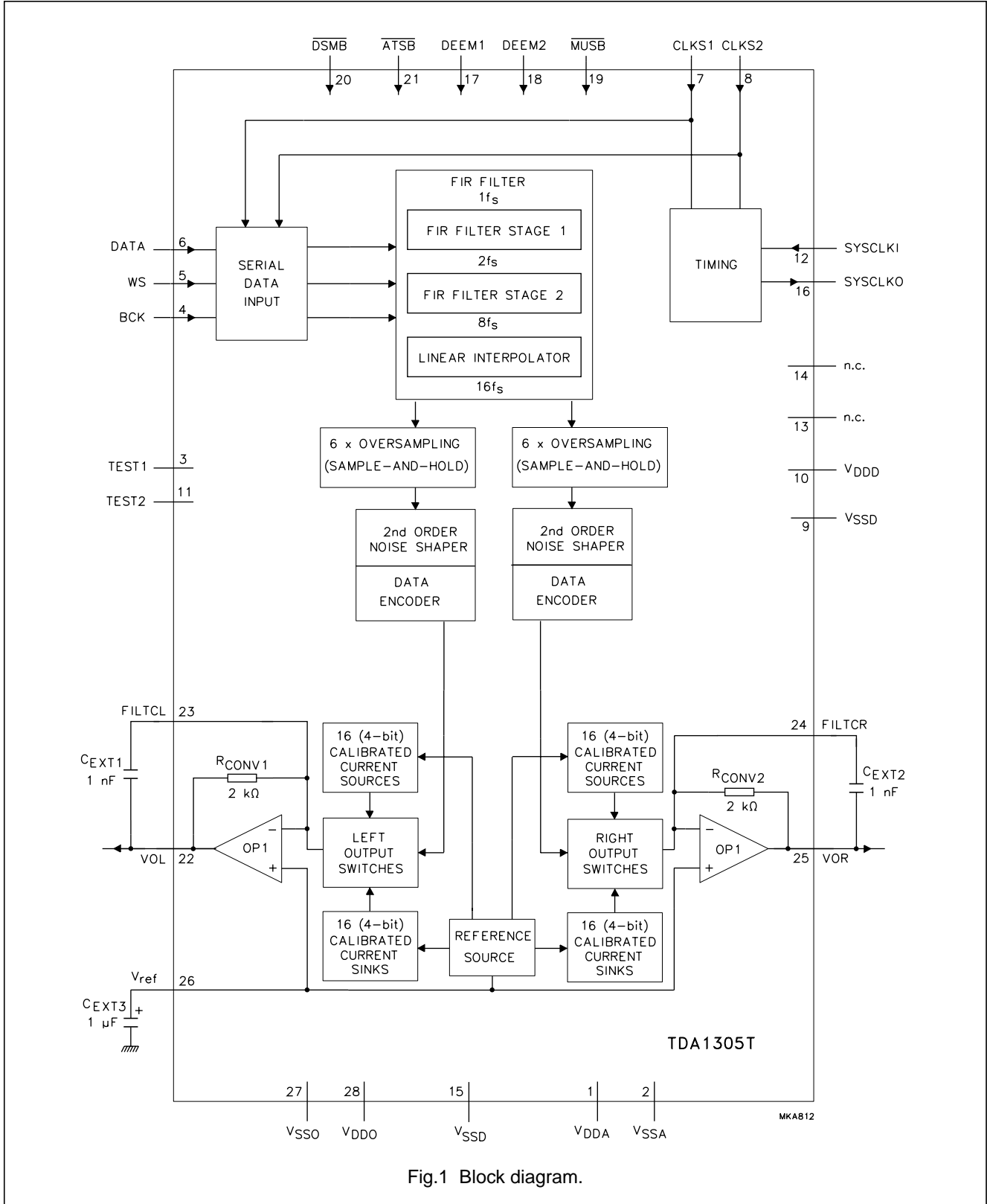

Fig.1 Block diagram.

Stereo 1fs data input up-sampling filter with bitstream continuous dual DAC (BCC-DAC2)

TDA1305T

PINNING

SYMBOL	PIN	DESCRIPTION
V _{DDA}	1	analog supply voltage
V _{SSA}	2	analog ground
TEST1	3	test input; pin should be connected to ground (internal pull-down resistor)
BCK	4	bit clock input
WS	5	word select input
DATA	6	data input
CLKS1	7	clock selection 1 input
CLKS2	8	clock selection 2 input
V _{SSD}	9	digital ground
V _{DDD}	10	digital supply voltage
TEST2	11	test input; pin should be connected to ground (internal pull-down resistor)
SYSCCLKI	12	system clock input
n.c.	13	not connected (this pin should be left open-circuit)
n.c.	14	not connected (this pin should be left open-circuit)
V _{SSD}	15	digital ground
SYSCCLKO	16	system clock output
DEEM1	17	de-emphasis on/off; f _{DEEM} 32 kHz, 44 kHz and 48 kHz
DEEM2	18	de-emphasis on/off; f _{DEEM} 32 kHz, 44 kHz and 48 kHz
MUSB	19	mute input (active LOW)
DSMB	20	double-speed mode input (active LOW)
ATSB	21	12 dB attenuation input (active LOW)
VOL	22	left channel output
FILTCL	23	capacitor for left channel 1st order filter function should be connected between pins 22 and 23
FILTCR	24	capacitor for right channel 1st order filter function should be connected between pins 25 and 24
VOR	25	right channel output
V _{ref}	26	internal reference voltage for output channels (0.5V _{DD})
V _{SSO}	27	operational amplifier ground
V _{DDO}	28	operational amplifier supply voltage

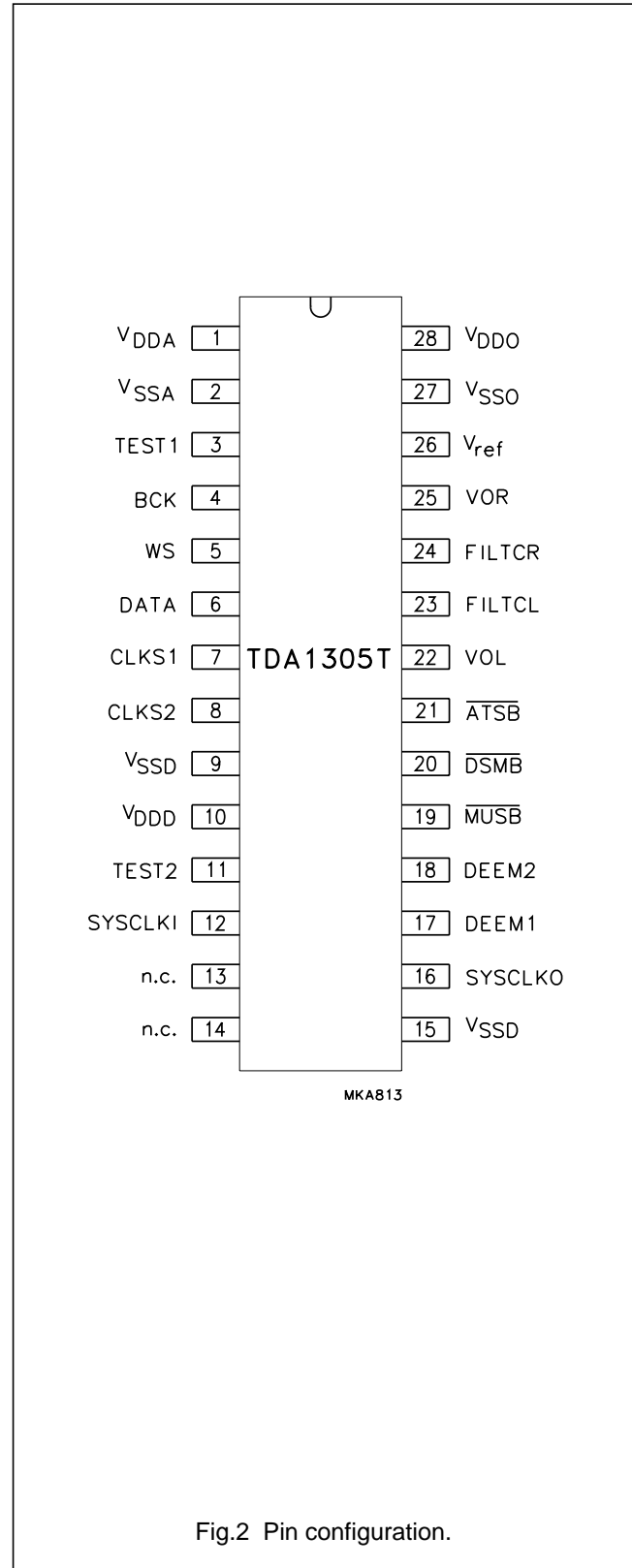

Fig.2 Pin configuration.

Stereo 1fs data input up-sampling filter with bitstream continuous dual DAC (BCC-DAC2)

TDA1305T

FUNCTIONAL DESCRIPTION

The TDA1305T CMOS digital-to-analog bitstream converter incorporates an up-sampling filter and noise shaper which increase the oversampling rate of $1f_s$ input data to $96f_s$ ($f_{sys} = 192f_s$) or $128f_s$ ($f_{sys} = 256f_s$) in the normal speed mode. In the double speed mode the oversample rate of $1f_s$ input data is increased to $48f_s$ ($f_{sys} = 384f_s$) or $64f_s$ ($f_{sys} = 256f_s$). This oversampling, together with the 5-bit DAC, enables the filtering required for waveform smoothing and out-of-band noise reduction to be achieved by simple 1st order analog post filtering.

System clock and data input format

The TDA1305T accommodates slave mode only, this means that in all applications the system devices must

provide a system clock of 256 or $384f_s$ ($f_s = 32, 44.1$ or 48 kHz). The system frequency is selectable by means of pin CLKS1 and pin CLKS2. The SYSCLKO output (pin 16) provides the system clock for external use.

The TDA1305T supports the following data input modes:

- I²S-bus with data word lengths of up to 20 bits (at $f_{sys} = 256f_s$).
- LSB fixed serial format with data word lengths of 16, 18 and 20 bits (at $f_{sys} = 384f_s$). As this format idles on the MSB it is necessary to know how many bits are being transmitted.

The input format is shown in Fig.3. Left and right data-channel words are time-multiplexed.

Table 1 Data input format and system clock.

TEST1	CLKS1	CLKS2	DATA INPUT FORMAT	SYSTEM CLOCK	DATA CLOCK ⁽¹⁾	SYSCLKO
0	0	0	I ² S up to 20 bits	$256f_s$	>20	$256f_s$
0	0	1	LSB fixed 16 bits	$384f_s$	24	$384f_s$
0	1	0	LSB fixed 18 bits	$384f_s$	24	$384f_s$
0	1	1	LSB fixed 20 bits	$384f_s$	24	$384f_s$
1	0	0	reserved	–	–	–
1	0	1	LSB fixed 16 bits	$384f_s$	32	$384f_s$
1	1	0	LSB fixed 18 bits	$384f_s$	32	$384f_s$
1	1	1	LSB fixed 20 bits	$384f_s$	32	$384f_s$

Note

1. Number of clock pulses within half an audio sample.

**Stereo 1fs data input up-sampling filter with
bitstream continuous dual DAC (BCC-DAC2)**

TDA1305T

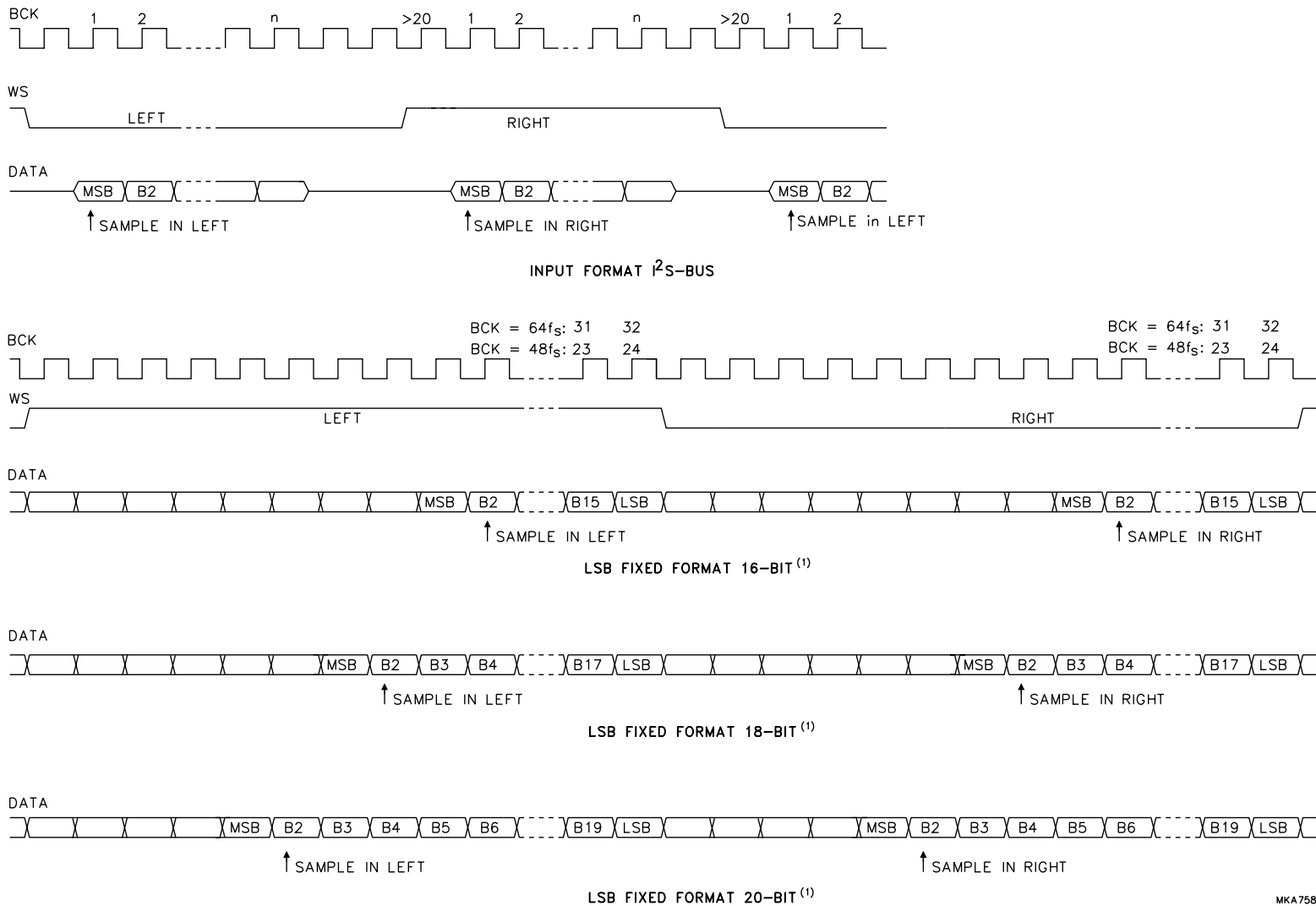

Fig.3 Input formats.

Stereo 1fs data input up-sampling filter with bitstream continuous dual DAC (BCC-DAC2)

TDA1305T

Mute

Soft mute is controlled by the $\overline{\text{MUSB}}$ at pin 9. When the input is active LOW the value of the samples is decreased smoothly to zero following a cosine curve. To step down the value of the data 32 coefficients are used, each one being used 31 times before stepping onto the next. When MUTE is released (pin 19 = HIGH), the samples are returned to the full level again following a cosine curve with the same coefficients being used in the reverse order. Mute is synchronized to prevent operation in the middle of a word.

De-emphasis

A digital de-emphasis is implemented for three sample rates (32, 44.1 and 48 kHz). By selecting DEEM1 and DEEM2 de-emphasis can be applied by means of a FIR filter. Time constants of the de-emphasis are 50 μs and 15 μs . De-emphasis is synchronized to prevent operation in the middle of a word. The de-emphasis deviation from ideal 50 μs and 15 μs de-emphasis is given in Table 4.

Table 2 De-emphasis.

DEEM1	DEEM2	CONDITION
0	0	de-emphasis disabled
0	1	de-emphasis for $f_s = 32$ kHz
1	0	de-emphasis for $f_s = 4.1$ kHz
1	1	de-emphasis for $f_s = 48$ kHz

Attenuation

Attenuation is controlled by the $\overline{\text{ATSB}}$ input (pin 21). When the input is active LOW the sample is multiplied by a coefficient that provides 12 dB attenuation. If the input is HIGH the multiplication factor is 1. Attenuation is synchronized to prevent operation in the middle of a word.

Double-speed mode

Double speed is controlled by the $\overline{\text{DSMB}}$ input (pin 20). When the input is active LOW the device operates in the double-speed mode.

Oversampling filter (normal-speed mode)

In the normal-speed mode the oversampling filter consists of:

- A 91st order half-band low-pass FIR filter which increases the oversampling rate from 1 time to 2 times.
- A 23rd order quarter band low-pass FIR filter which increases the oversampling rate from 2 times to 8 times.
- A linear interpolation section which increases the oversampling rate to 16 times. This removes the spectral components around $8f_s$.
- A sample-and-hold section which provides another 6 times oversampling to 96 times. The zero-order hold characteristic of this sample-and-hold section plus the 1st order analog filtering remove the spectral components around $16f_s$.

Pass-band ripple and stop-band attenuation for normal-speed are given in Table 3.

Oversampling filter (double-speed mode)

In the double-speed mode the oversampling filter consists of:

- A 51st order half-band low-pass FIR filter which increases the oversampling rate from 1 time to 2 times.
- A 7th order half-band low-pass FIR filter which increases the oversampling rate from 2 times to 4 times.
- A linear interpolation section which increases the oversampling rate to 8 times. This removes the spectral components around $4f_s$.
- A sample-and-hold section which provides another 6 times oversampling to 48 times. The zero-order hold characteristic of this sample-and-hold section plus the 1st order analog filtering remove the spectral components around $8f_s$.

Pass-band ripple and stop-band attenuation for double-speed are given in Table 3.

Stereo 1fs data input up-sampling filter with bitstream continuous dual DAC (BCC-DAC2)

TDA1305T

Noise shaper

In the normal speed mode the 2nd order digital noise shaper operates at $96f_s$ ($f_{sys} = 384f_s$) or $128f_s$ ($f_{sys} = 256f_s$). The digital noise shaper operates at $48f_s$ ($f_{sys} = 384f_s$) or $64f_s$ ($f_{sys} = 256f_s$) in double-speed mode. It shifts in-band quantization noise to frequencies well above the audio band. This noise shaping technique used in combination with a special data coding enables extremely high signal-to-noise ratios to be achieved. The noise shaper outputs a 5-bit pulse duration modulation (PDM) bitstream signal to the DAC.

Continuous calibration DAC

The dual 5-bit DAC uses the continuous calibration technique. This method, based on charge storage, involves exact duplication of a single reference current source. In the TDA1305T, 32 such current sources plus 1 spare source are continuously calibrated. The spare source is included to allow continuous converter operation.

The DAC receives a 5-bit data bitstream from the noise shaper. This data is then converted so that only small currents are switched to the output during digital silence

(input 00000H). Using this technique extremely high signal-to-noise performance is achieved.

Operational amplifiers

High precision, low-noise amplifiers together with the internal conversion resistors R_{CONV1} and R_{CONV2} convert the converter output current to a voltage capable of driving a line output. This voltage is available at VOL and VOR (1.5 V RMS typical).

Connecting external capacitors CEXT1 and CEXT2 between FILTCL and VOL and between FILTCR and VOR respectively provides the required 1st order post filtering for the left and right channels (see Fig.1). The combinations of R_{CONV1} with CEXT1 and R_{CONV2} with CEXT2 determine the 1st order fall-off frequencies.

Internal reference circuitry

Internal reference circuitry ensures that the output voltage signal is proportional to the supply voltage, thereby maintaining maximum dynamic range for supply voltages from 3.4 to 5.5 V and making the circuit also suitable for battery-powered applications.

LIMITING VALUES

In accordance with the Absolute Maximum Rating System (IEC 134).

SYMBOL	PARAMETER	CONDITIONS	MIN.	MAX.	UNIT
V_{DDD}	digital supply voltage		–	7.0	V
V_{DDA}	analog supply voltage		–	7.0	V
V_{DDO}	operational amplifier supply voltage		–	7.0	V
T_{xtal}	maximum crystal temperature		–	+150	°C
T_{stg}	storage temperature		–65	+150	°C
T_{amb}	ambient operating temperature		–30	+85	°C
V_{es}	electrostatic handling	note 1	–2000	+2000	V
		note 2	–200	+200	V

Notes

- Human body model; C = 100 pF, R = 1500 Ω , V = 2000 V, 3 pulses positive and 3 pulses negative.
- Machine model; C = 200 pF, R = 10 Ω , L = 0.5 μ H.

THERMAL CHARACTERISTICS

SYMBOL	PARAMETER	VALUE	UNIT
$R_{th j-a}$	thermal resistance from junction to ambient in free air	75	K/W

Stereo 1fs data input up-sampling filter with bitstream continuous dual DAC (BCC-DAC2)

TDA1305T

QUALITY SPECIFICATION

In accordance with "SNW-FQ-611E". The number of this quality specification can be found in the "Quality Reference Handbook". The handbook can be ordered using the code 9398 510 63011.

DIGITAL CHARACTERISTICS

$V_{DD} = 3.4$ to 5.5 V; $V_{SS} = 0$ V; $T_{amb} = -40$ to $+85$ °C; unless otherwise specified.

SYMBOL	PARAMETER	CONDITIONS	MIN.	TYP.	MAX.	UNIT
Supply						
V_{DDD}	digital supply voltage	note 1	3.4	5.0	5.5	V
I_{DDD}	digital supply current	$V_{DDD} = 5$ V; at code 00000H	–	30	40	mA
V_{DDA}	analog supply voltage	note 1	3.4	5.0	5.5	V
I_{DDA}	analog supply current	$V_{DDA} = 5$ V; at code 00000H	–	5.5	8	mA
V_{DDO}	operational amplifier supply voltage	note 1	3.4	5.0	5.5	V
I_{DDO}	operational amplifier supply current	$V_{DDO} = 5$ V; at code 00000H	–	6.5	9	mA
RR	ripple rejection to V_{DDA}	note 2	–	25	–	dB
System clock input						
f_{sys}	system frequency	$f_{sys} = 384f_s$	9.6	16.93	18.4	MHz
		$f_{sys} = 256f_s$	6.4	11.29	12.28	MHz
V_{IL}	LOW level input voltage	note 3	–0.5	–	$0.2V_{DD}$	V
V_{IH}	HIGH level input voltage	note 3	$0.8V_{DD}$	–	$V_{DD} + 0.5$	V
$ I_{LI} $	input leakage current	note 4	–	–	10	μ A
C_i	input capacitance		–	–	10	pF
T_{cy}	clock cycle time	$f_{sys} = 384f_s$	104	59.1	54.2	ns
		$f_{sys} = 256f_s$	156	88.6	81.3	ns
Digital inputs; \overline{WS}, \overline{BCK}, \overline{DATA}, \overline{DSMB}, \overline{MUSB}, $\overline{DEEM1}$, $\overline{DEEM2}$, \overline{ATSB}, $\overline{CLKS1}$, $\overline{CLKS2}$, $\overline{TEST1}$ and $\overline{TEST2}$						
V_{IL}	LOW level input voltage	note 3	–0.5	–	$0.3V_{DD}$	V
V_{IH}	HIGH level input voltage	note 3	$0.7V_{DD}$	–	$V_{DD} + 0.5$	V
$ I_{LI} $	input leakage current	note 4	–	–	10	μ A
C_i	input capacitance		–	–	10	pF
Digital output; CDEC						
V_{OL}	LOW level output voltage	$I_{OL} = 0.4$ mA	0	–	0.5	V
V_{OH}	HIGH level output voltage	$I_{OH} = -0.2$ mA	$V_{DD} - 0.5$	–	V_{DD}	V
t_r	output rise time	note 5	–	–	20	ns
t_f	output fall time	note 5	–	–	20	ns
C_L	load capacitance		–	–	30	pF

Stereo 1fs data input up-sampling filter with
bitstream continuous dual DAC (BCC-DAC2)

TDA1305T

SYMBOL	PARAMETER	CONDITIONS	MIN.	TYP.	MAX.	UNIT
Serial input data timing (see Fig.4)						
f _{BCK}	bit-clock input (data input rate) frequency	f _{sys} = 384f _s	–	48f _s	–	MHz
		f _{sys} = 256f _s	–	64f _s	–	MHz
f _{WS}	word select input frequency	normal speed	25	44.1	48	kHz
		double speed	50	88.2	96	kHz
t _r	rise time		–	–	20	ns
t _f	fall time		–	–	20	ns
t _H	bit clock time HIGH		55	–	–	ns
t _L	bit clock time LOW		55	–	–	ns
t _{su}	data set-up time		40	–	–	ns
t _h	data hold time		10	–	–	ns
t _{suWS}	word select set-up time		40	–	–	ns
t _{hWS}	word select hold time		10	–	–	ns

Notes

- All V_{DD} and V_{SS} pins must be connected externally to the same supply.
- V_{ripple} = 1% of supply voltage; f_{ripple} = 100 Hz. Ripple rejection RR to V_{DDA} is dependent on the value of the external capacitor (C_{EXT3} in Fig.1) connected to V_{ref}. The value here assumes that C_{EXT3} = 1 μF.
- Minimum V_{IL} and maximum V_{IH} are peak values to allow for transients.
- I_{LImni} measured at V_I = 0 V; I_{LImax} measured at V_I = 5.5 V.
- Reference levels = 10% and 90%.

ANALOG CHARACTERISTICSV_{DD} = V_{DDA} = V_{DDO} = 5 V; V_{SS} = 0 V; T_{amb} = 25 °C; unless otherwise specified.

SYMBOL	PARAMETER	CONDITIONS	MIN.	TYP.	MAX.	UNIT
Reference values						
V _{ref}	reference voltage level		2.45	2.5	2.55	V
R _{CONV}	current-to-voltage conversion resistor		1.6	2.2	2.8	kΩ
Analog outputs						
RES	resolution		–	–	18	bit
V _{FS(rms)}	full-scale output voltage (pins 23 and 25) (RMS value)		1.425	1.5	1.575	V
V _{OFF}	output voltage DC offset with respect to reference voltage level V _{ref}		–80	–65	–50	mV
TC _{FS}	full scale temperature coefficient		–	±100 × 10 ^{–6}	–	

Stereo 1fs data input up-sampling filter with
bitstream continuous dual DAC (BCC-DAC2)

TDA1305T

SYMBOL	PARAMETER	CONDITIONS	MIN.	TYP.	MAX.	UNIT
(THD + N)/S	total harmonic distortion plus noise-to-signal ratio	at 0 dB input level; note 1	–	–90	–81	dB
			–	0.003	0.009	%
		at –60 dB input level; note 2	–	–44	–40	dB
			–	0.63	1.0	%
		at –60 dB input level; A-weighted; note 3	–	–46	–	dB
			–	0.5	–	%
		at 0 dB input level; (20 Hz to 20 kHz); note 4	–	–90	–81	dB
			–	0.003	0.003	%
S/N	signal-to-noise ratio at bipolar zero	A weighted; at code (00000H)	100	108	–	dB
α_{cs}	channel separation		85	100	–	dB
$ \delta V_O $	unbalance between outputs		–	0.2	0.3	dB
$ Z_O $	dynamic output impedance		–	10	–	Ω
R_L	output load resistance		3	–	–	k Ω
C_L	output load capacitance		–	–	200	pF

Notes

1. Measured with a 1 kHz, 0 dB, 18-bit sine wave generated at a sampling rate of 48 kHz. The (THD + N)/S measured over a bandwidth of 20 Hz to 20 kHz.
2. Measured with a 1 kHz, –60 dB, 18-bit sine wave generated at a sampling rate of 48 kHz. The (THD + N)/S measured over a bandwidth of 20 Hz to 20 kHz. For 16-bit input signals, the performance is limited to the theoretical maximum.
3. Measured with a 1 kHz, –60 dB, 18-bit sine wave generated at a sampling rate of 48 kHz. The (THD + N)/S measured over a bandwidth of 20 Hz to 20 kHz and filtered with a A-weighted characteristic. For 16-bit input signals, the performance is limited to the theoretical maximum.
4. Measured with a sine wave from 20 Hz to 20 kHz generated at a sampling rate of 48 kHz. The (THD + N)/S measured over a bandwidth of 20 Hz to 20 kHz.

TEST AND APPLICATION INFORMATION**Filter characteristics (theoretical values)****Table 3** Normal speed filter characteristics.

ITEM	SAMPLE FREQUENCY	RANGE	CONDITIONS	CHARACTERISTICS
Pass band	44.1 kHz	0 to 20 kHz		0 ±0.025 dB
	32 kHz	14.5 to 15 kHz		–0.15 dB (min.)
Stop band	44.1 kHz	24.1 to 150 kHz	typical	–60 dB (max.)
			worst case	–57 dB (max.)
	32 kHz	150 kHz to infinity	typical	–57 dB (max.)
			worst case	–47 dB (max.)
	32 kHz	17 to 17.5 kHz		–40 dB (max.)

Stereo 1fs data input up-sampling filter with bitstream continuous dual DAC (BCC-DAC2)

TDA1305T

De-emphasis filter characteristics (theoretical values)

Table 4 De-emphasis deviation from ideal 50 μ s to 15 μ s de-emphasis network.

ITEM	SAMPLE FREQUENCY	RANGE	CHARACTERISTICS
Gain deviation	44.1 and 48 kHz	0 to 18 kHz	0 \pm 0.05 dB
		18 to 20 kHz	0.12 dB (max.)
	32 kHz	0 to 13 kHz	0 \pm 0.06 dB
		13 to 15 kHz	0.22 dB (max.)
Phase deviation	44.1 and 48 kHz	0 to 15 kHz	10 deg (max.)
		15 to 20 kHz	15 deg (max.)
	32 kHz	0 to 9 kHz	10 deg (max.)
		9 to 15 kHz	16 deg (max.)

Double-speed characteristics

Table 5 Double-speed filter characteristics.

ITEM	RANGE	CONDITIONS	CHARACTERISTICS
Pass band	0 to 17 kHz		0 \pm 0.075 dB
	17 to 20 kHz		-0.3 dB (min.)
Stop band	24.1 to 150 kHz	typical	-47 dB (max.)
		worst case	-45 dB (max.)
	150 kHz to infinite	typical	-33 dB (max.)
		worst case	-25 dB (max.)

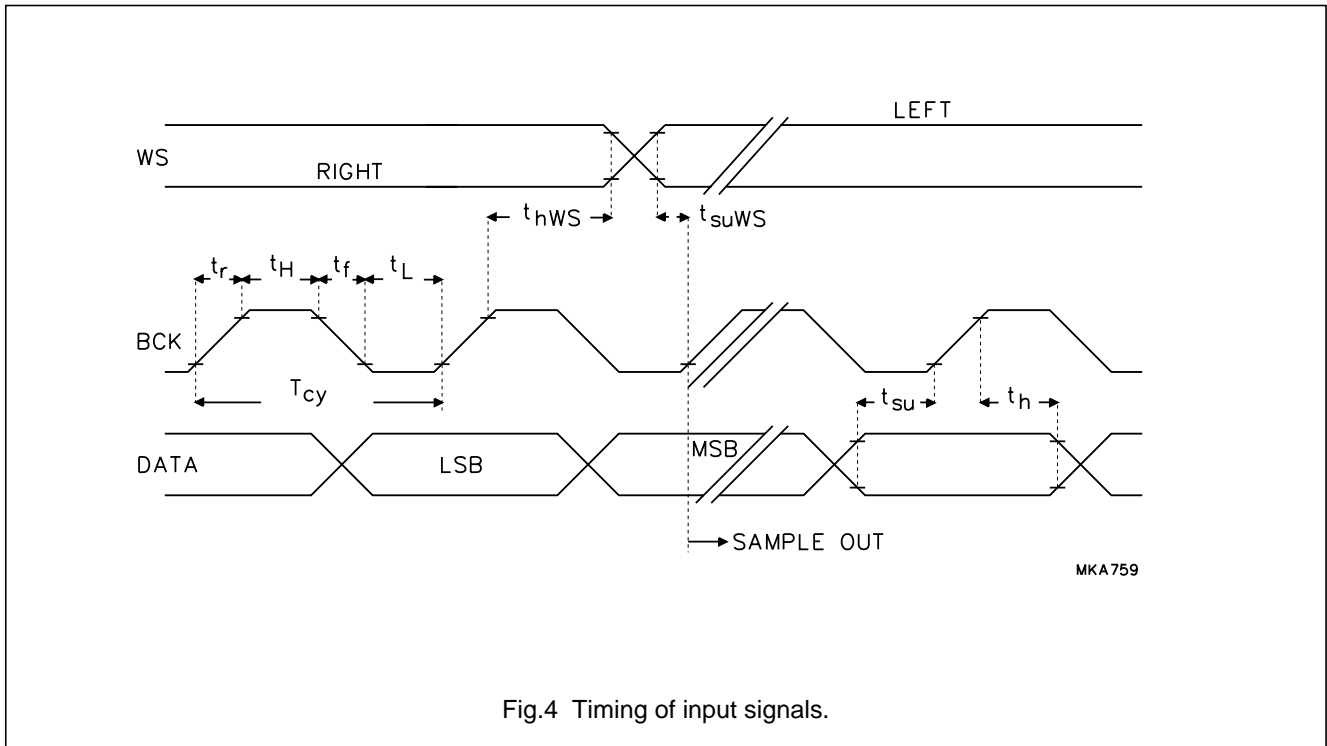

Fig.4 Timing of input signals.

Stereo 1fs data input up-sampling filter with bitstream continuous dual DAC (BCC-DAC2)

TDA1305T

APPLICATION INFORMATION

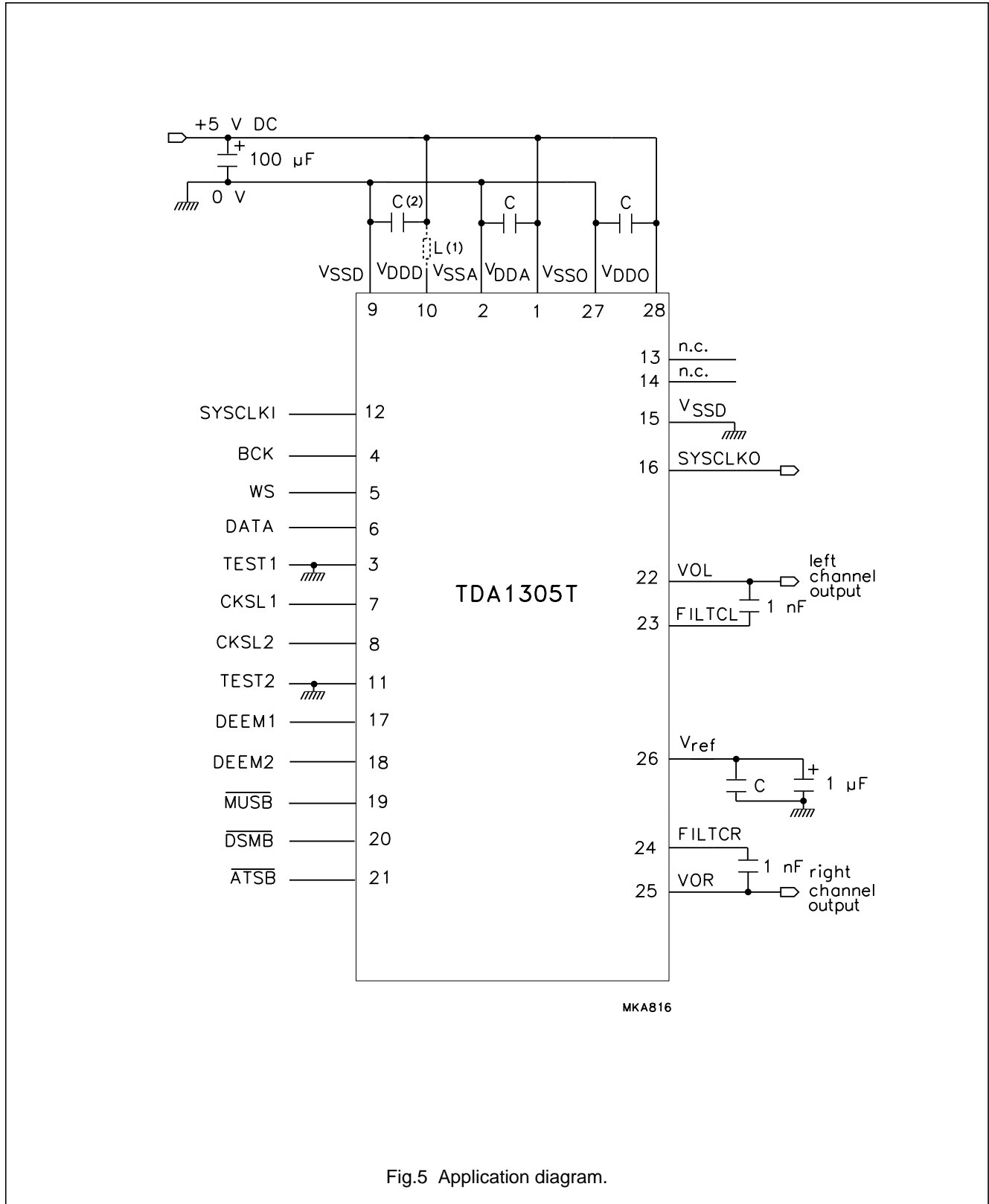

Fig.5 Application diagram.

Stereo 1fs data input up-sampling filter with bitstream continuous dual DAC (BCC-DAC2)

TDA1305T

A typical application diagram is illustrated in Fig.5. The left and right channel outputs can drive a line output directly. The series inductor (L) in the digital supply line, though not strictly necessary, helps to reduce crosstalk between the digital and analog circuits.

In Fig.6 measurements were taken with an 18-bit sine wave generated at a sampling rate of 48 kHz. The (THD + N)/S was measured over a bandwidth of 20 Hz to 20 kHz. The graph was constructed from average

measurement values of a small amount of engineering samples. No guarantee for typical values is implied.

In Fig.6 measurements were taken with an 18-bit sine wave generated at a sampling rate of 48 kHz. The (THD + N)/S was measured over a bandwidth of 20 Hz to 20 kHz and filtered with A-weighted characteristics. The graph was constructed from average measurement values of a small amount of engineering samples. No guarantee for typical values is implied.

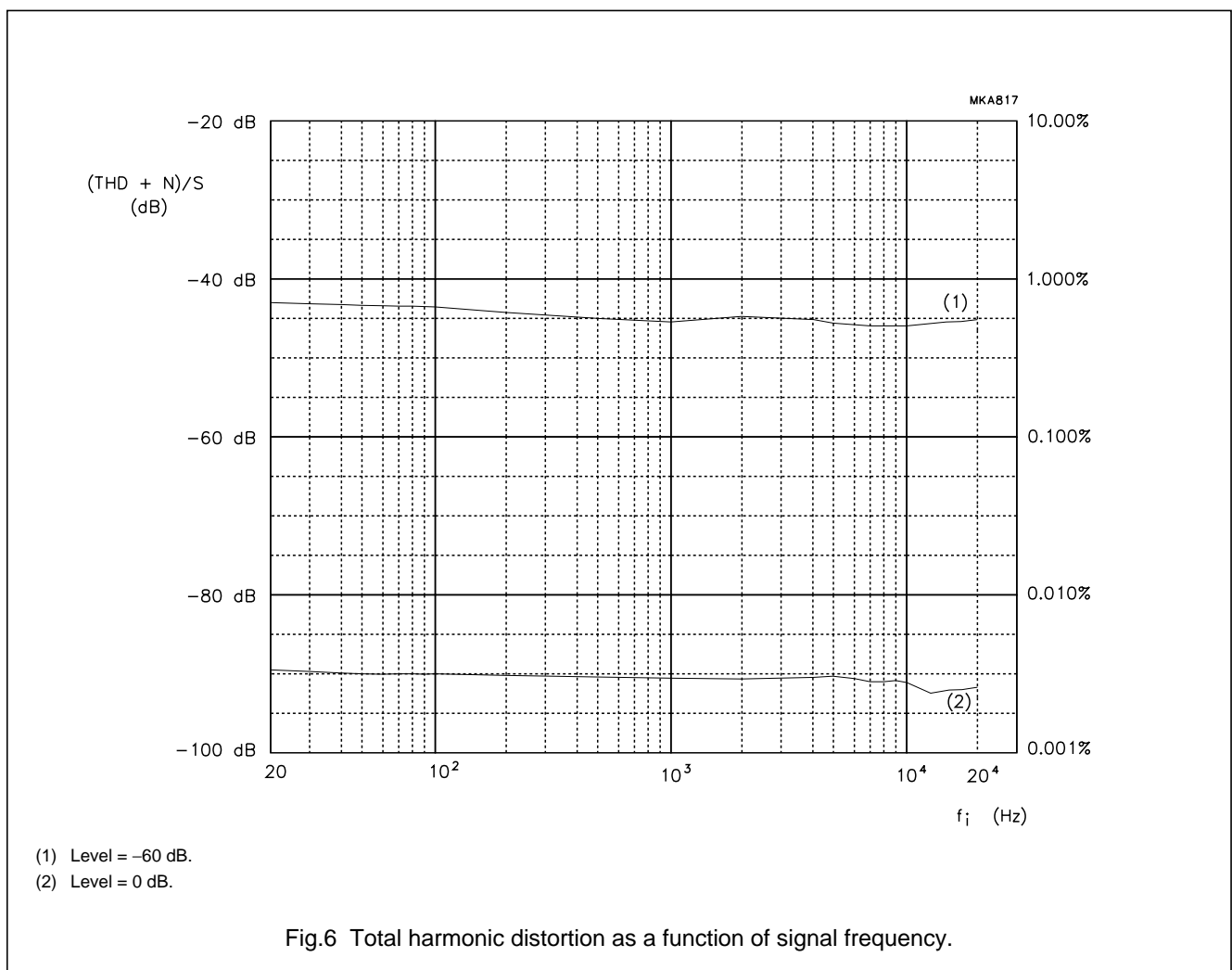

Stereo 1fs data input up-sampling filter with
bitstream continuous dual DAC (BCC-DAC2)

TDA1305T

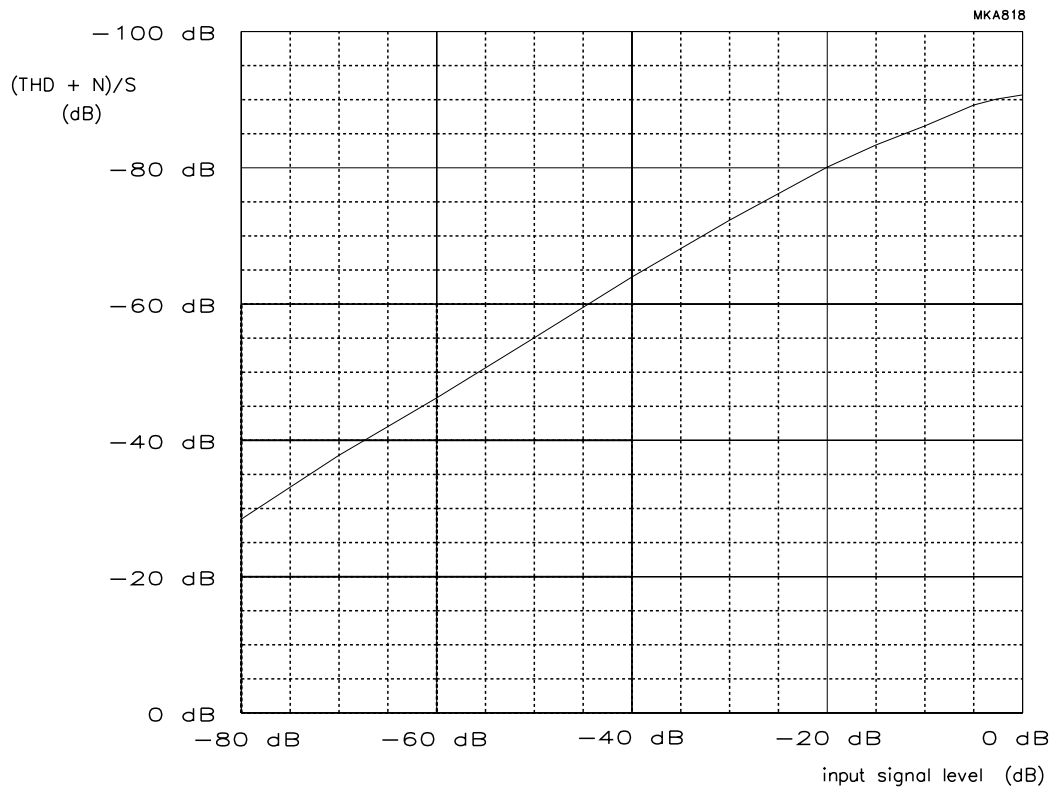

Fig.7 Total harmonic distortion as a function of signal level; (A-weighted).

Stereo 1fs data input up-sampling filter with bitstream continuous dual DAC (BCC-DAC2)

TDA1305T

PACKAGE OUTLINE

SO28: plastic small outline package; 28 leads; body width 7.5 mm

SOT136-1

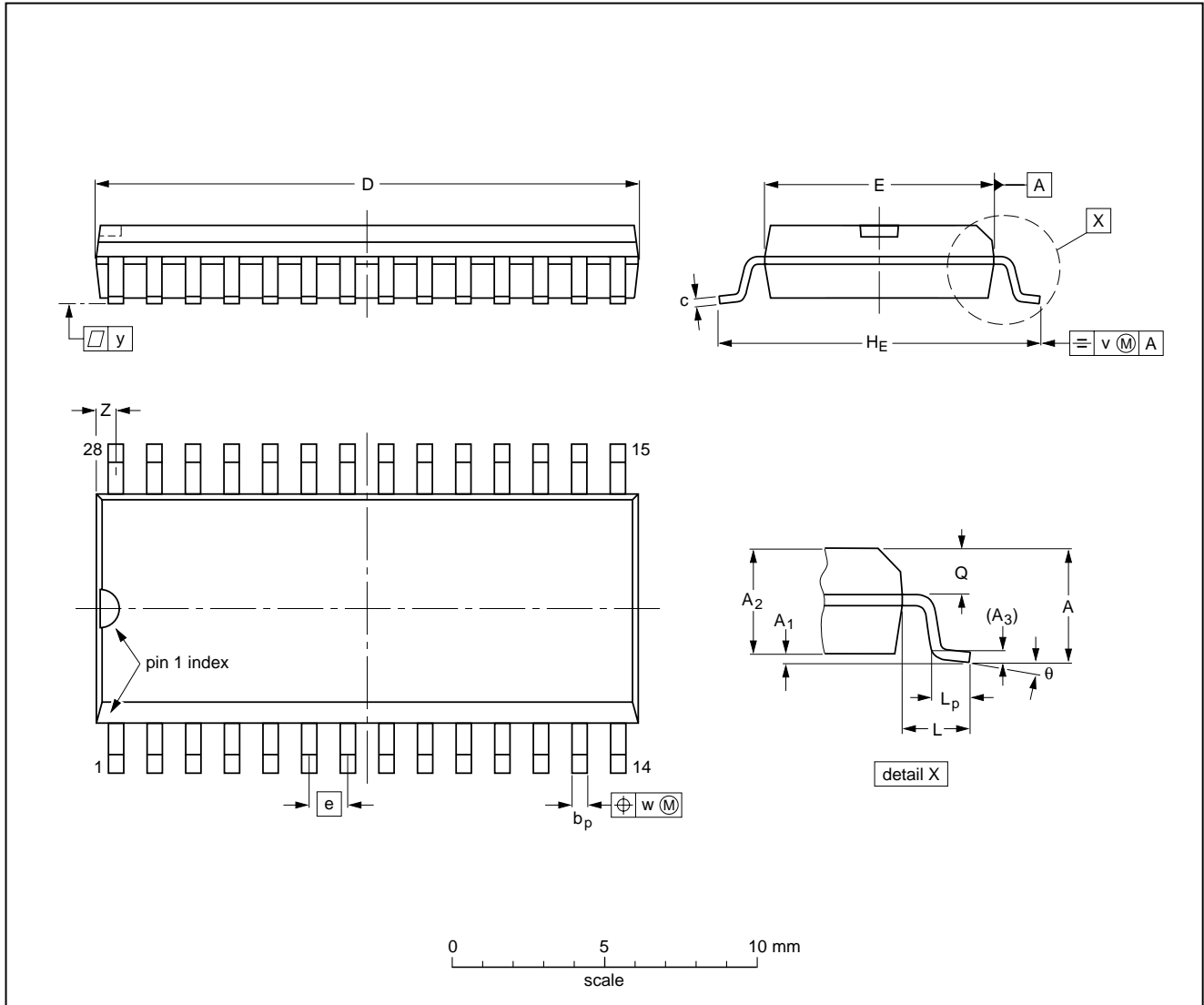

DIMENSIONS (inch dimensions are derived from the original mm dimensions)

UNIT	A max.	A ₁	A ₂	A ₃	b _p	c	D ⁽¹⁾	E ⁽¹⁾	e	H _E	L	L _p	Q	v	w	y	Z ⁽¹⁾	θ
mm	2.65	0.30 0.10	2.45 2.25	0.25	0.49 0.36	0.32 0.23	18.1 17.7	7.6 7.4	1.27	10.65 10.00	1.4	1.1 0.4	1.1 1.0	0.25	0.25	0.1	0.9 0.4	8° 0°
inches	0.10	0.012 0.004	0.096 0.089	0.01	0.019 0.014	0.013 0.009	0.71 0.69	0.30 0.29	0.050	0.419 0.394	0.055	0.043 0.016	0.043 0.039	0.01	0.01	0.004	0.035 0.016	

Note

1. Plastic or metal protrusions of 0.15 mm maximum per side are not included.

OUTLINE VERSION	REFERENCES			EUROPEAN PROJECTION	ISSUE DATE
	IEC	JEDEC	EIAJ		
SOT136-1	075E06	MS-013AE			95-01-24 97-05-22

Stereo 1fs data input up-sampling filter with bitstream continuous dual DAC (BCC-DAC2)

TDA1305T

SOLDERING

Introduction

There is no soldering method that is ideal for all IC packages. Wave soldering is often preferred when through-hole and surface mounted components are mixed on one printed-circuit board. However, wave soldering is not always suitable for surface mounted ICs, or for printed-circuits with high population densities. In these situations reflow soldering is often used.

This text gives a very brief insight to a complex technology. A more in-depth account of soldering ICs can be found in our "*IC Package Databook*" (order code 9398 652 90011).

Reflow soldering

Reflow soldering techniques are suitable for all SO packages.

Reflow soldering requires solder paste (a suspension of fine solder particles, flux and binding agent) to be applied to the printed-circuit board by screen printing, stencilling or pressure-syringe dispensing before package placement.

Several techniques exist for reflowing; for example, thermal conduction by heated belt. Dwell times vary between 50 and 300 seconds depending on heating method. Typical reflow temperatures range from 215 to 250 °C.

Preheating is necessary to dry the paste and evaporate the binding agent. Preheating duration: 45 minutes at 45 °C.

Wave soldering

Wave soldering techniques can be used for all SO packages if the following conditions are observed:

- A double-wave (a turbulent wave with high upward pressure followed by a smooth laminar wave) soldering technique should be used.
- The longitudinal axis of the package footprint must be parallel to the solder flow.
- The package footprint must incorporate solder thieves at the downstream end.

During placement and before soldering, the package must be fixed with a droplet of adhesive. The adhesive can be applied by screen printing, pin transfer or syringe dispensing. The package can be soldered after the adhesive is cured.

Maximum permissible solder temperature is 260 °C, and maximum duration of package immersion in solder is 10 seconds, if cooled to less than 150 °C within 6 seconds. Typical dwell time is 4 seconds at 250 °C.

A mildly-activated flux will eliminate the need for removal of corrosive residues in most applications.

Repairing soldered joints

Fix the component by first soldering two diagonally-opposite end leads. Use only a low voltage soldering iron (less than 24 V) applied to the flat part of the lead. Contact time must be limited to 10 seconds at up to 300 °C. When using a dedicated tool, all other leads can be soldered in one operation within 2 to 5 seconds between 270 and 320 °C.

Stereo 1fs data input up-sampling filter with bitstream continuous dual DAC (BCC-DAC2)

TDA1305T

DEFINITIONS

Data sheet status	
Objective specification	This data sheet contains target or goal specifications for product development.
Preliminary specification	This data sheet contains preliminary data; supplementary data may be published later.
Product specification	This data sheet contains final product specifications.
Limiting values	
Limiting values given are in accordance with the Absolute Maximum Rating System (IEC 134). Stress above one or more of the limiting values may cause permanent damage to the device. These are stress ratings only and operation of the device at these or at any other conditions above those given in the Characteristics sections of the specification is not implied. Exposure to limiting values for extended periods may affect device reliability.	
Application information	
Where application information is given, it is advisory and does not form part of the specification.	

LIFE SUPPORT APPLICATIONS

These products are not designed for use in life support appliances, devices, or systems where malfunction of these products can reasonably be expected to result in personal injury. Philips customers using or selling these products for use in such applications do so at their own risk and agree to fully indemnify Philips for any damages resulting from such improper use or sale.

Philips Semiconductors – a worldwide company

Argentina: IEROD, Av. Juramento 1992 - 14.b, (1428)
BUENOS AIRES, Tel. (541)786 7633, Fax. (541)786 9367

Australia: 34 Waterloo Road, NORTH RYDE, NSW 2113,
Tel. (02)805 4455, Fax. (02)805 4466

Austria: Triester Str. 64, A-1101 WIEN, P.O. Box 213,
Tel. (01)60 101-1236, Fax. (01)60 101-1211

Belgium: Postbus 90050, 5600 PB EINDHOVEN, The Netherlands,
Tel. (31)40-2783749, Fax. (31)40-2788399

Brazil: Rua do Rocio 220 - 5th floor, Suite 51,
CEP: 04552-903-SÃO PAULO-SP, Brazil,
P.O. Box 7383 (01064-970),
Tel. (011)821-2333, Fax. (011)829-1849

Canada: PHILIPS SEMICONDUCTORS/COMPONENTS:
Tel. (800) 234-7381, Fax. (708) 296-8556

Chile: Av. Santa Maria 0760, SANTIAGO,
Tel. (02)773 816, Fax. (02)777 6730

China/Hong Kong: 501 Hong Kong Industrial Technology Centre,
72 Tat Chee Avenue, Kowloon Tong, HONG KONG,
Tel. (852)2319 7888, Fax. (852)2319 7700

Colombia: IPRELENZO LTDA, Carrera 21 No. 56-17,
77621 BOGOTA, Tel. (571)249 7624/(571)217 4609,
Fax. (571)217 4549

Denmark: Prags Boulevard 80, PB 1919, DK-2300
COPENHAGEN S, Tel. (45)32 88 26 36, Fax. (45)31 57 19 49

Finland: Sinikalliontie 3, FIN-02630 ESPOO,
Tel. (358)0-615 800, Fax. (358)0-61580 920

France: 4 Rue du Port-aux-Vins, BP317,
92156 SURESNES Cedex,
Tel. (01)4099 6161, Fax. (01)4099 6427

Germany: P.O. Box 10 51 40, 20035 HAMBURG,
Tel. (040)23 53 60, Fax. (040)23 53 63 00

Greece: No. 15, 25th March Street, GR 17778 TAVROS,
Tel. (01)4894 339/4894 911, Fax. (01)4814 240

India: Philips INDIA Ltd, Shivsagar Estate, A Block,
Dr. Annie Besant Rd. Worli, Bombay 400 018
Tel. (022)4938 541, Fax. (022)4938 722

Indonesia: Philips House, Jalan H.R. Rasuna Said Kav. 3-4,
P.O. Box 4252, JAKARTA 12950,
Tel. (021)5201 122, Fax. (021)5205 189

Ireland: Newstead, Clonskeagh, DUBLIN 14,
Tel. (01)7640 000, Fax. (01)7640 200

Italy: PHILIPS SEMICONDUCTORS S.r.l.,
Piazza IV Novembre 3, 20124 MILANO,
Tel. (0039)2 6752 2531, Fax. (0039)2 6752 2557

Japan: Philips Bldg 13-37, Kohnan2-chome, Minato-ku, TOKYO 108,
Tel. (03)3740 5130, Fax. (03)3740 5077

Korea: Philips House, 260-199 Itaewon-dong,
Yongsan-ku, SEOUL, Tel. (02)709-1412, Fax. (02)709-1415

Malaysia: No. 76 Jalan Universiti, 46200 PETALING JAYA,
SELANGOR, Tel. (03)750 5214, Fax. (03)757 4880

Mexico: 5900 Gateway East, Suite 200, EL PASO, TX 79905,
Tel. 9-5(800)234-7381, Fax. (708)296-8556

Netherlands: Postbus 90050, 5600 PB EINDHOVEN, Bldg. VB,
Tel. (040)2783749, Fax. (040)2788399

New Zealand: 2 Wagener Place, C.P.O. Box 1041, AUCKLAND,
Tel. (09)849-4160, Fax. (09)849-7811

Norway: Box 1, Manglerud 0612, OSLO,
Tel. (022)74 8000, Fax. (022)74 8341

Pakistan: Philips Electrical Industries of Pakistan Ltd.,
Exchange Bldg. ST-2/A, Block 9, KDA Scheme 5, Clifton,
KARACHI 75600, Tel. (021)587 4641-49,
Fax. (021)577035/5874546

Philippines: PHILIPS SEMICONDUCTORS PHILIPPINES Inc.,
106 Valero St. Salcedo Village, P.O. Box 2108 MCC, MAKATI,
Metro MANILA, Tel. (63) 2 816 6380, Fax. (63) 2 817 3474

Portugal: PHILIPS PORTUGUESA, S.A.,
Rua dr. António Loureiro Borges 5, Arquiparque - Miraflores,
Apartado 300, 2795 LINDA-A-VELHA,
Tel. (01)4163160/4163333, Fax. (01)4163174/4163366

Singapore: Lorong 1, Toa Payoh, SINGAPORE 1231,
Tel. (65)350 2000, Fax. (65)251 6500

South Africa: S.A. PHILIPS Pty Ltd.,
195-215 Main Road Martindale, 2092 JOHANNESBURG,
P.O. Box 7430, Johannesburg 2000,
Tel. (011)470-5911, Fax. (011)470-5494

Spain: Balmes 22, 08007 BARCELONA,
Tel. (03)301 6312, Fax. (03)301 42 43

Sweden: Kottbygatan 7, Akalla. S-164 85 STOCKHOLM,
Tel. (0)8-632 2000, Fax. (0)8-632 2745

Switzerland: Allmendstrasse 140, CH-8027 ZÜRICH,
Tel. (01)488 2211, Fax. (01)481 77 30

Taiwan: PHILIPS TAIWAN Ltd., 23-30F, 66, Chung Hsiao West
Road, Sec. 1. Taipeh, Taiwan ROC, P.O. Box 22978,
TAIPEI 100, Tel. (886) 2 382 4443, Fax. (886) 2 382 4444

Thailand: PHILIPS ELECTRONICS (THAILAND) Ltd.,
209/2 Sanpavuth-Bangna Road Prakanong,
Bangkok 10260, THAILAND,
Tel. (66) 2 745-4090, Fax. (66) 2 398-0793

Turkey: Talatpasa Cad. No. 5, 80640 GÜLTEPE/ISTANBUL,
Tel. (0212)279 27 70, Fax. (0212)282 67 07

Ukraine: Philips UKRAINE, 2A Akademika Koroleva str., Office 165,
252148 KIEV, Tel. 380-44-4760297, Fax. 380-44-4766991

United Kingdom: Philips Semiconductors LTD.,
276 Bath Road, Hayes, MIDDLESEX UB3 5BX,
Tel. (0181)730-5000, Fax. (0181)754-8421

United States: 811 East Arques Avenue, SUNNYVALE,
CA 94088-3409, Tel. (800)234-7381, Fax. (708)296-8556

Uruguay: Coronel Mora 433, MONTEVIDEO,
Tel. (02)70-4044, Fax. (02)92 0601

Internet: <http://www.semiconductors.philips.com/ps/>

For all other countries apply to: Philips Semiconductors,
International Marketing and Sales, Building BE-p,
P.O. Box 218, 5600 MD EINDHOVEN, The Netherlands,
Telex 35000 phtcnl, Fax. +31-40-2724825

SCD47

© Philips Electronics N.V. 1995

All rights are reserved. Reproduction in whole or in part is prohibited without the prior written consent of the copyright owner.

The information presented in this document does not form part of any quotation or contract, is believed to be accurate and reliable and may be changed without notice. No liability will be accepted by the publisher for any consequence of its use. Publication thereof does not convey nor imply any license under patent- or other industrial or intellectual property rights.

Printed in The Netherlands

513061/50/02/pp20

Document order number:

Date of release: 1995 Dec 08

9397 750 00517

This datasheet has been download from:

www.datasheetcatalog.com

Datasheets for electronics components.



TECHNICAL INFORMATION

TASCAM CD-RW5000, Tray Clamp

No.	9921
DATE	3rd September 1999

If a huge shock is applied to the unit during transportation, there is a possibility that the mechanism comes out of bosses causing that the tray cannot be opened.

In order to hold the mechanism, a tray clamp has been added on the disc tray.
It is recommended to fit the tray clamp after the servicing with inserting a sheet attached in the following page.

Tray Clamp, P/No. V000882-00A

Before you use the unit:

Important! In order to protect the unit during transportation and shipping, a red clamp is fitted in the disc tray. Before you use the CD-RW5000, make sure that this is removed, as shown below.

Keep the clamp so that you can re-fit it if you need to move or transport the CD-RW5000 in the future.

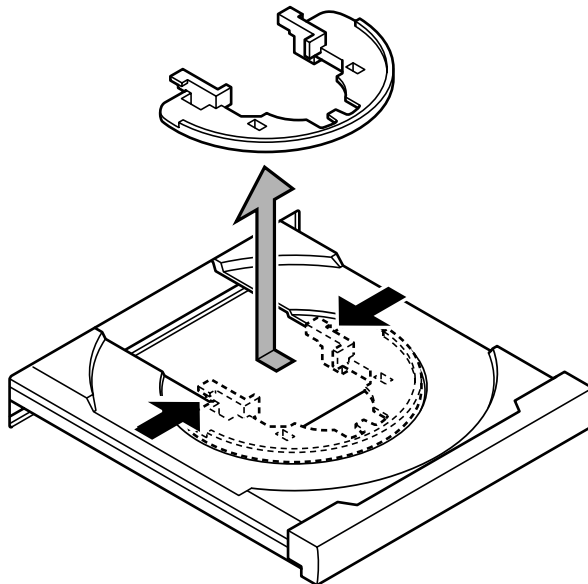

TEAC**TECHNICAL INFORMATION****TASCAM CD-RW5000, Slit Washer**No. **9933**
DATE 17th December 1999

This is an addition to Tech-Info No. 9921.

With No. 9921, a tray clamp has been applied to protect the mechanism from external huge shock causing that the mechanism comes out of bosses.

In order to increase a safety margin furthermore, slit washer, **P/No. V000886-00A** has become newly available for service purpose. Note that there is no products that have the slit washers mounted since the production of the mechanism has been discontinued.

It is recommended to fit the tray clamp and the slit washers after the servicing.

Insert the slit washer between boss and rubber damper.
4 pcs of the slit washer are required for one unit.

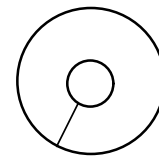
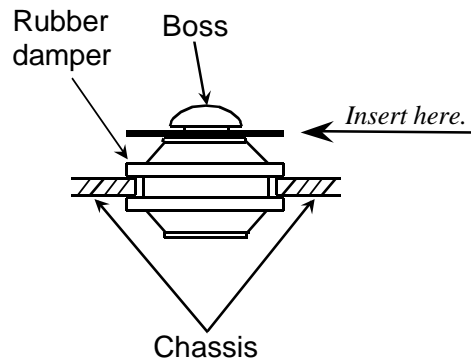
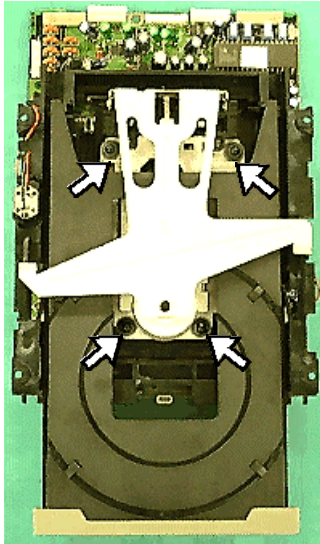

slit washer (3.3×10×0.25t)
P/No. V000886-00A

TEAC**TECHNICAL INFORMATION****TASCAM CD-RW5000, ROM Upgrade (Main V1.4)**No. **9932**

DATE 1st December 1999

Main ROM (Ref 1-25) has been upgraded from V1.3 to V1.4 on the products with S/No. 9X00001 and higher.

	P/No. (PGMed ROM)	P/No. (Blank ROM)
V1.4	91670557-01	91670522-00 (STM27C2001-12F1)

Problem corrected by V1.4

Copy from the CD-RW5000 SPDIF output to SCMS recorders is impossible under following conditions.

1. Make a recording on the CD-RW5000.
2. Connect CD-RW5000 SPDIF output to SCMS recorder.
3. Start recording on the SCMS recorder.
4. Start playback of track one on the CD-RW5000 with the disc made at paragraph 1.
5. SCMS recorder stops to record.

Cause of problem is that the CD-RW5000 records copy prohibit flag at the most beginning of Track one. If track one is reproduced from behind the most beginning, no problem occurs.

If this disc is reproduced by other standard CD players, no problem occurs as they do not output the copy prohibit flag.