

**回路図**

**CONTENTS 目次**

FRONT .....	2
SYS (1/3) .....	3
SYS (2/3) .....	4
SYS (3/3) .....	5
GATHER .....	6
REG .....	7
GATHER REAR (1/3) .....	8
GATHER REAR (2/3) .....	9
GATHER REAR (3/3) .....	10
Wiring .....	11

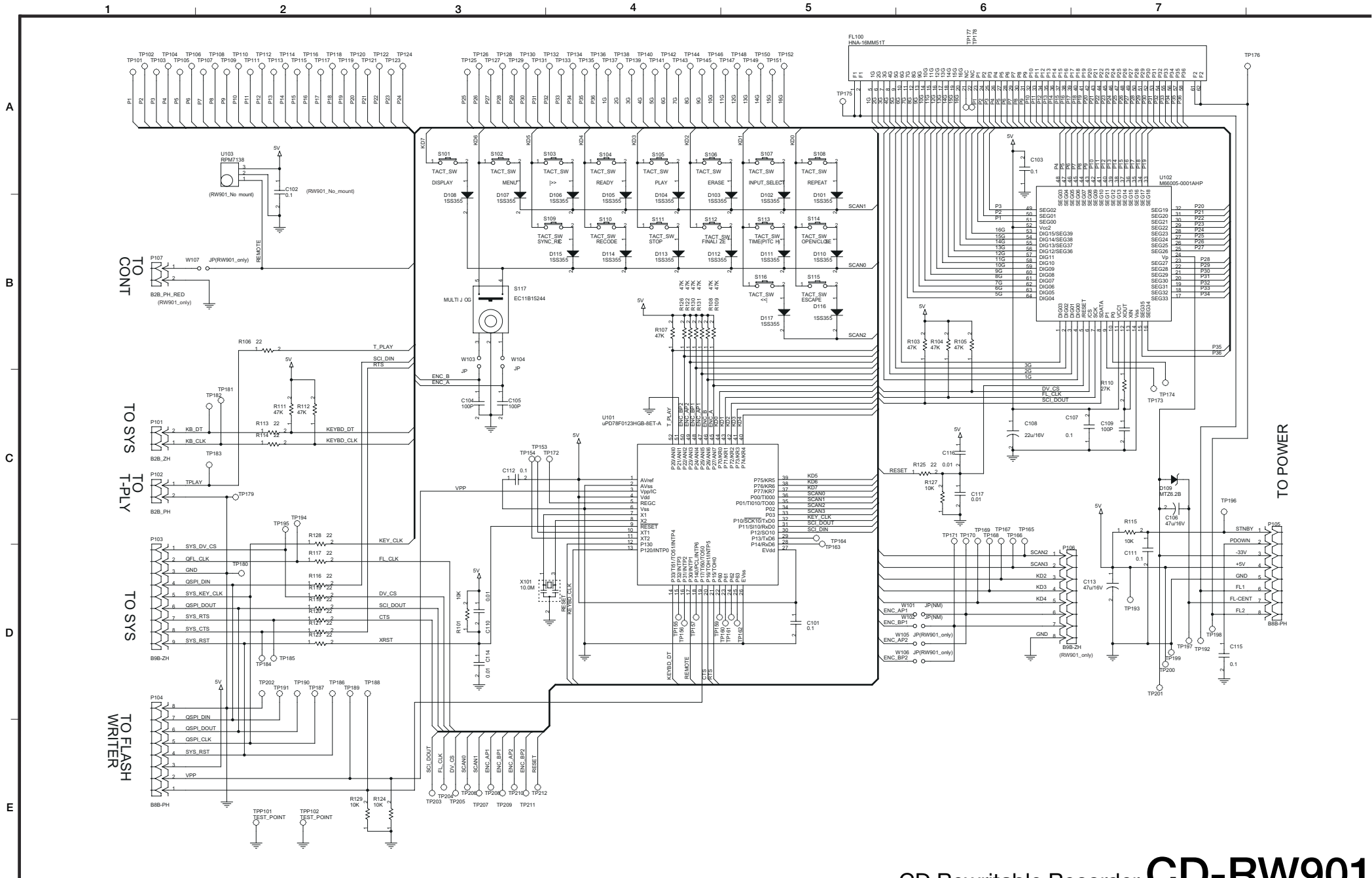

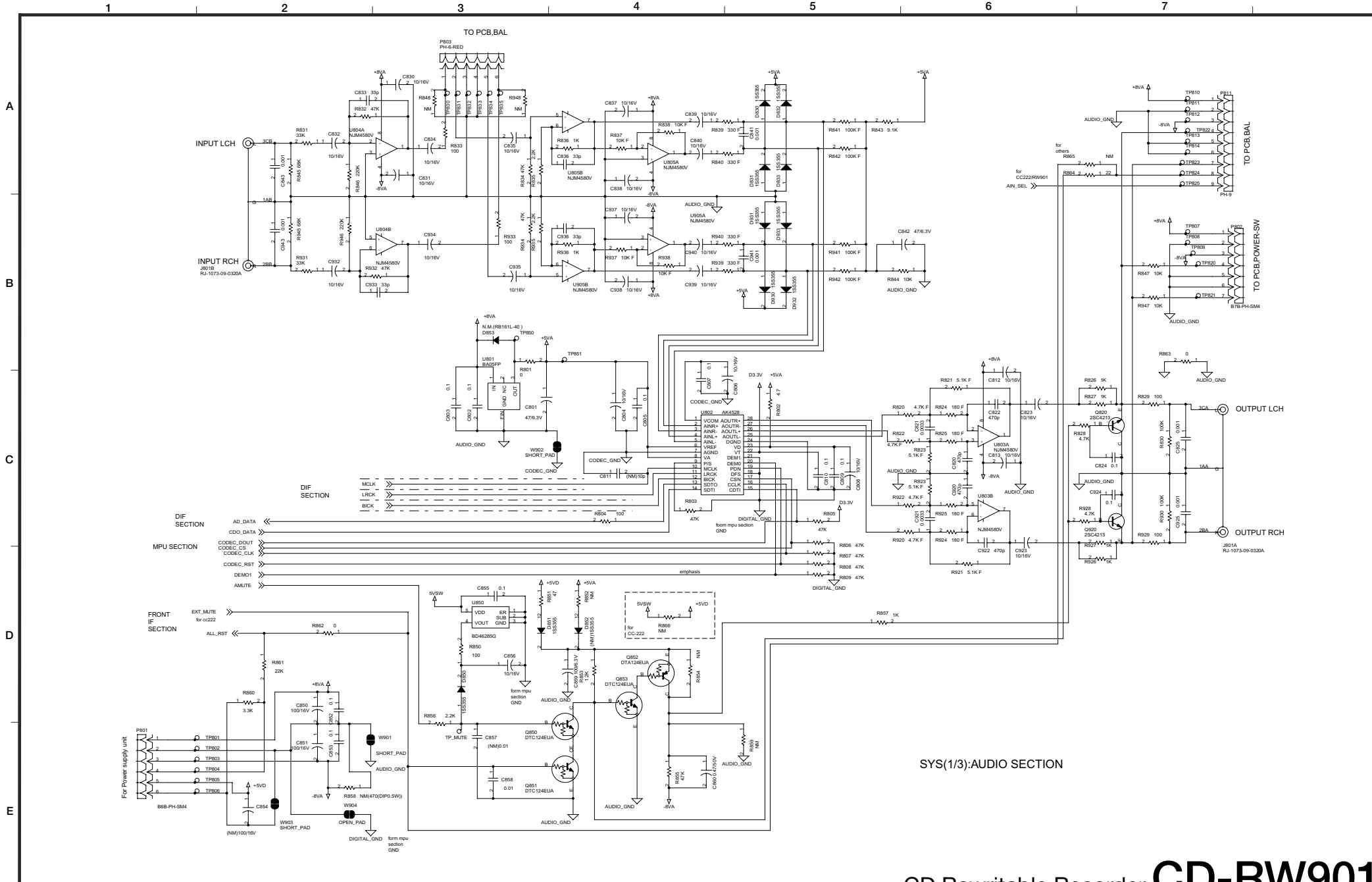

SYS(1/3):AUDIO SECTION

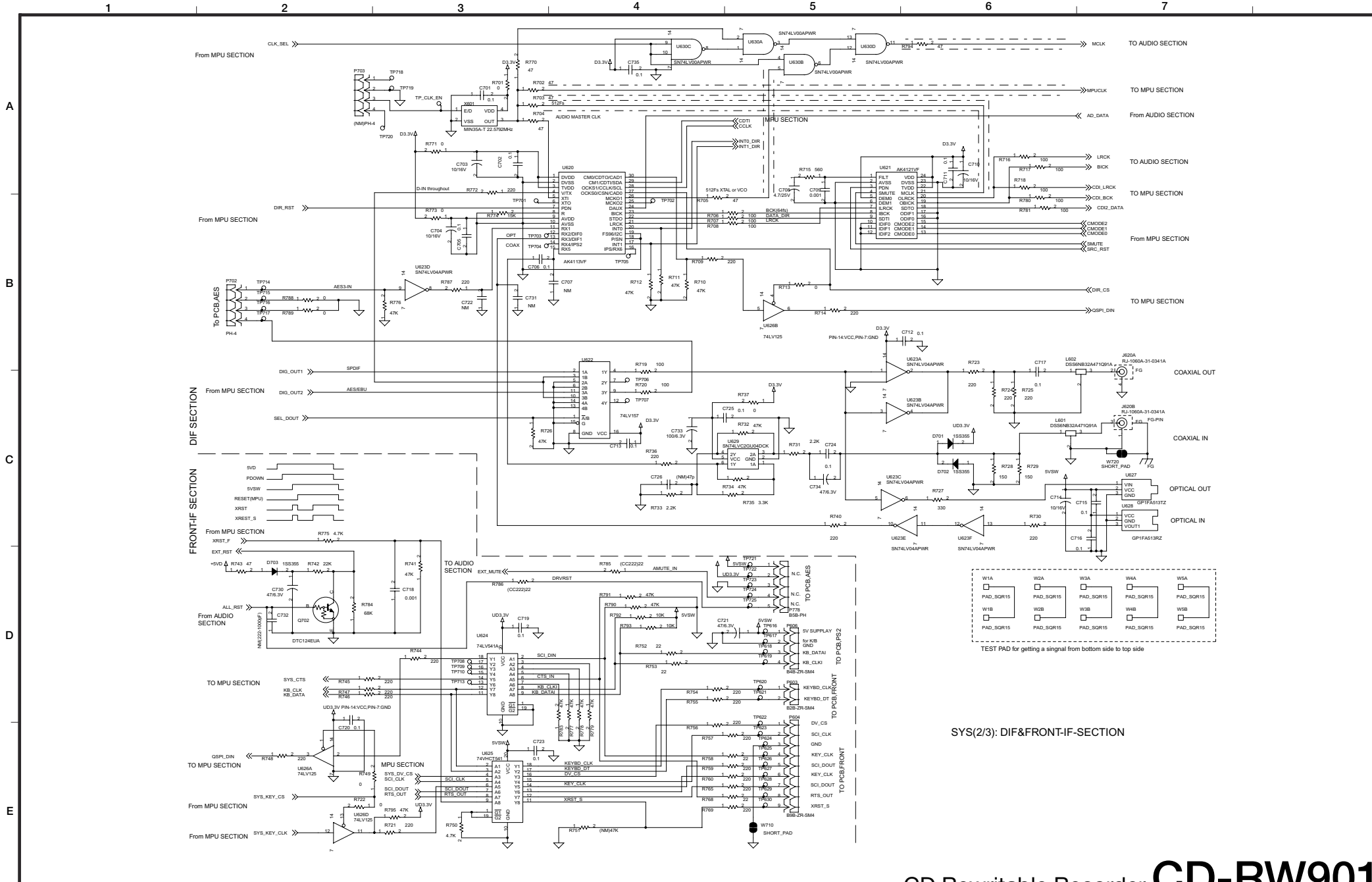

SYS(2/3): DIF&FRONT-IF-SECTION

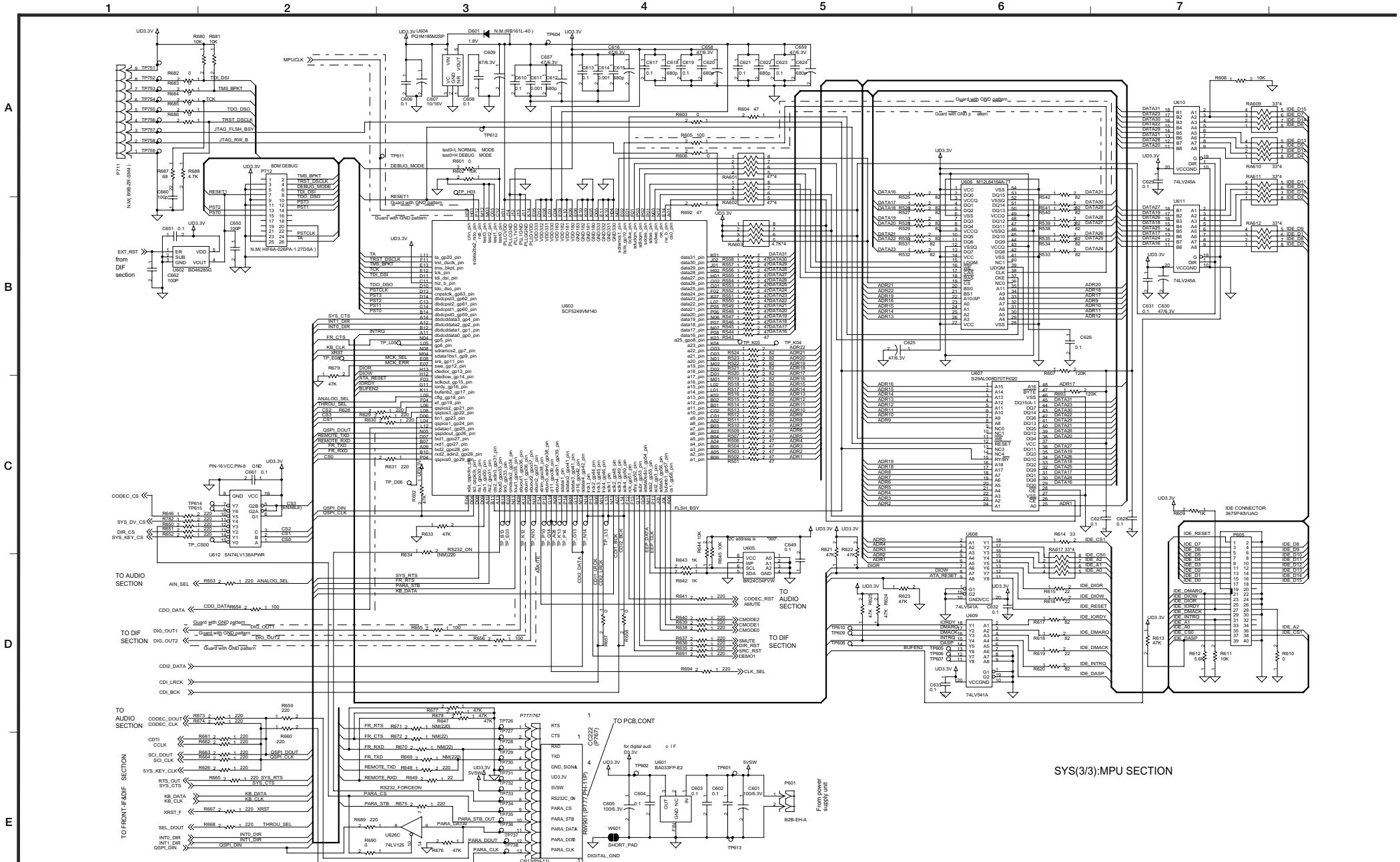

SYS(3/3):MPU SECTION

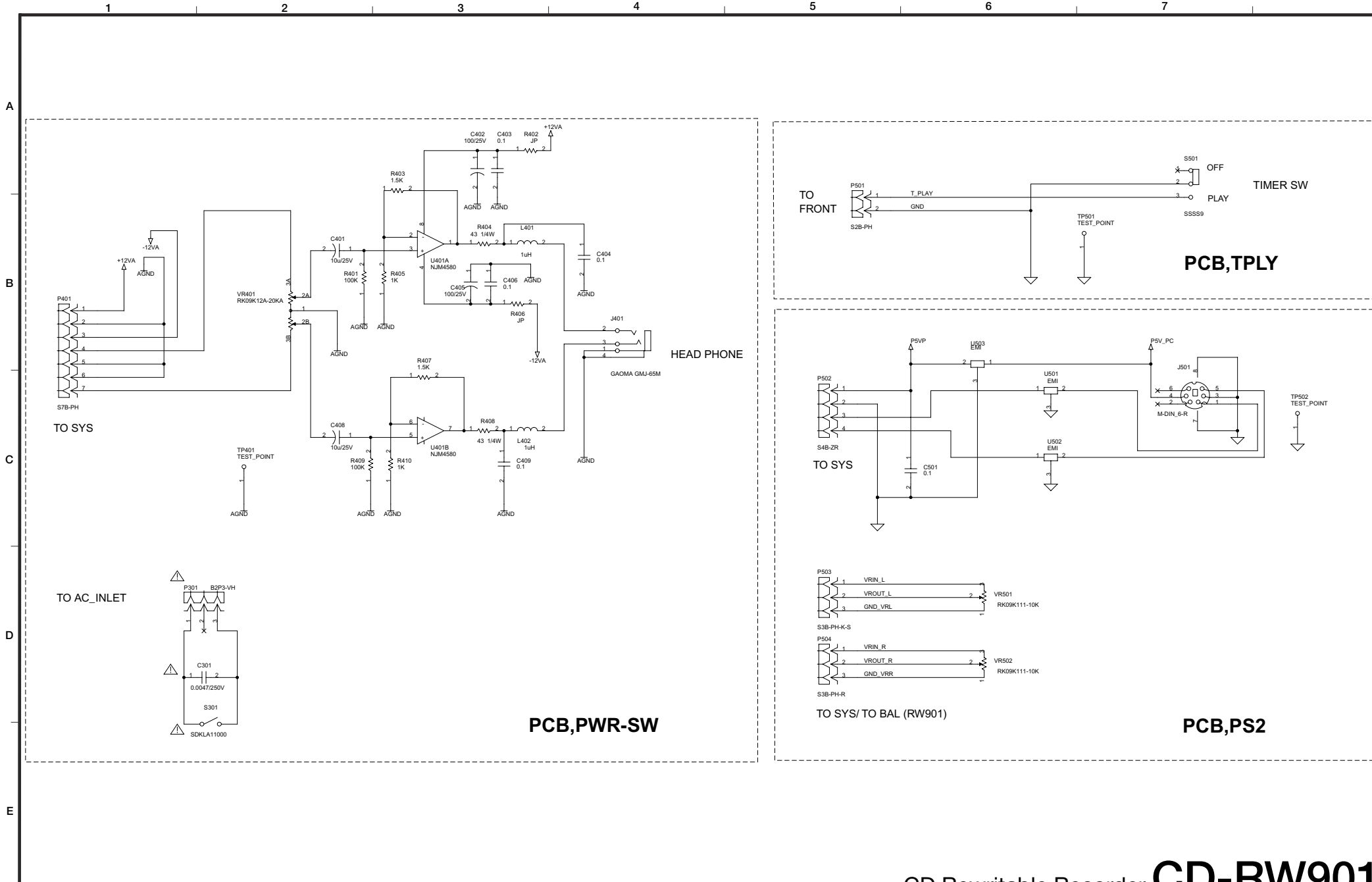

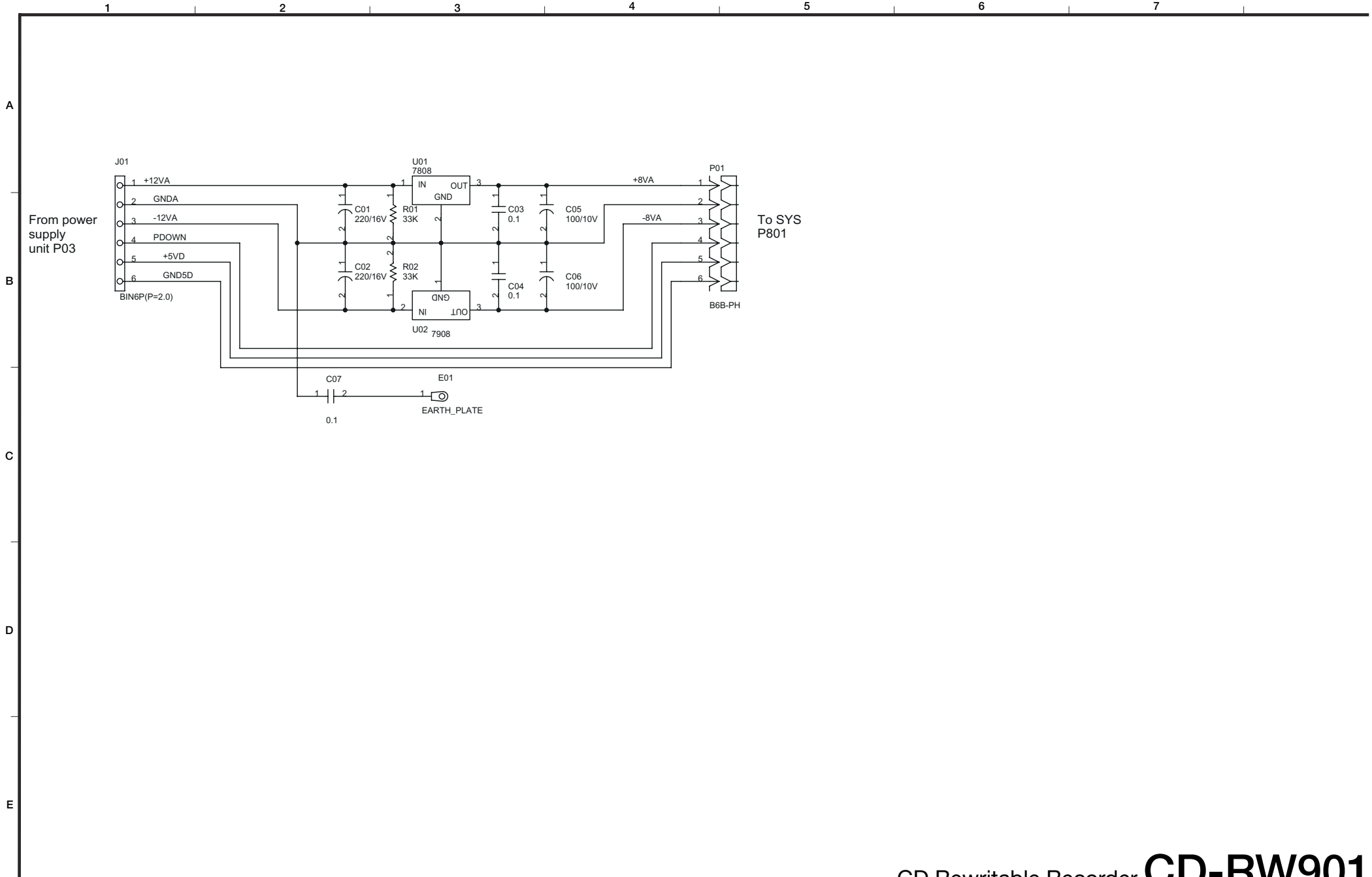

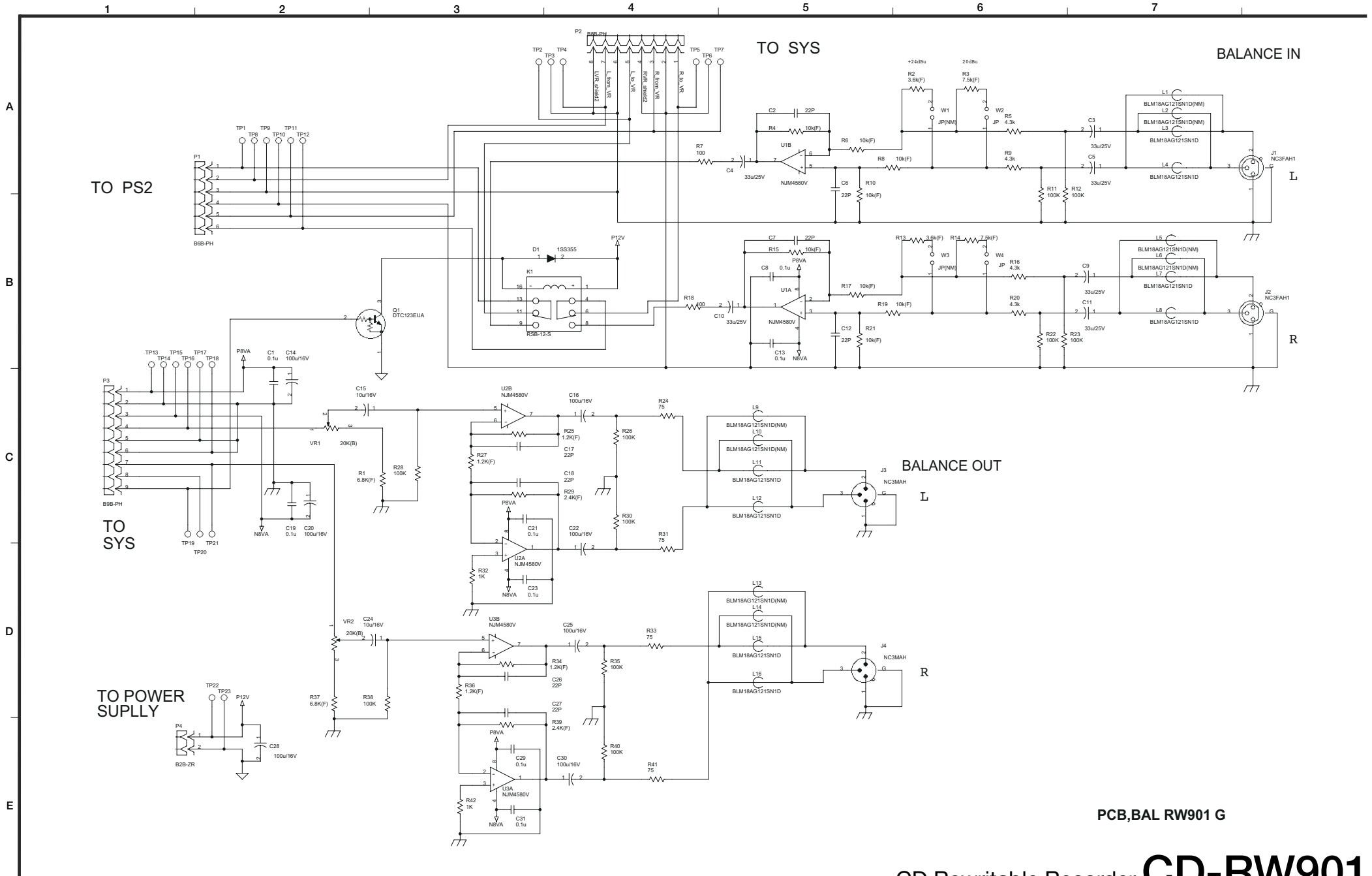

PCB,BAL RW901 G

CD Rewritable Recorder **CD-RW901**

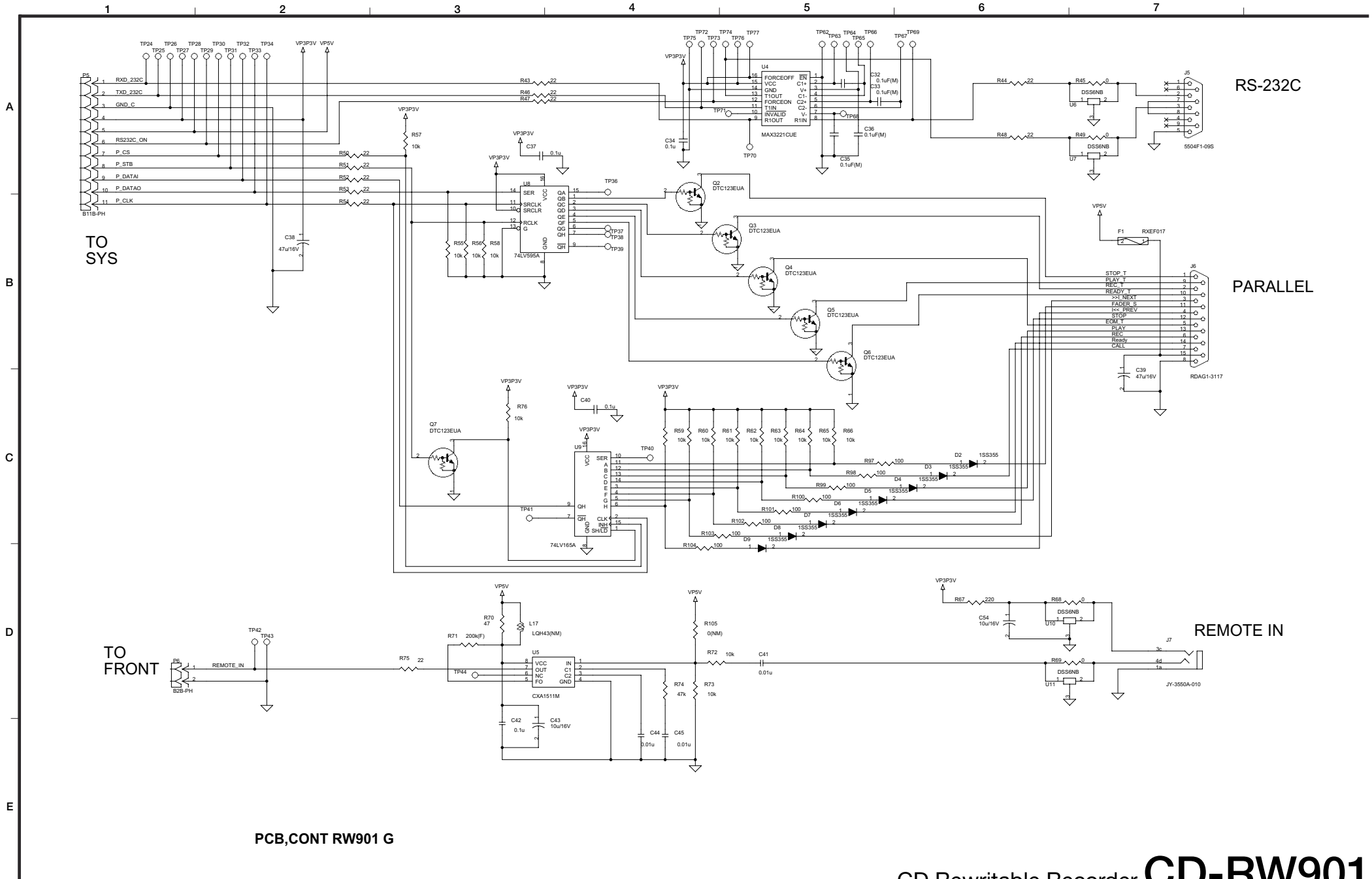

PCB,CONT RW901 G

CD Rewritable Recorder **CD-RW901**

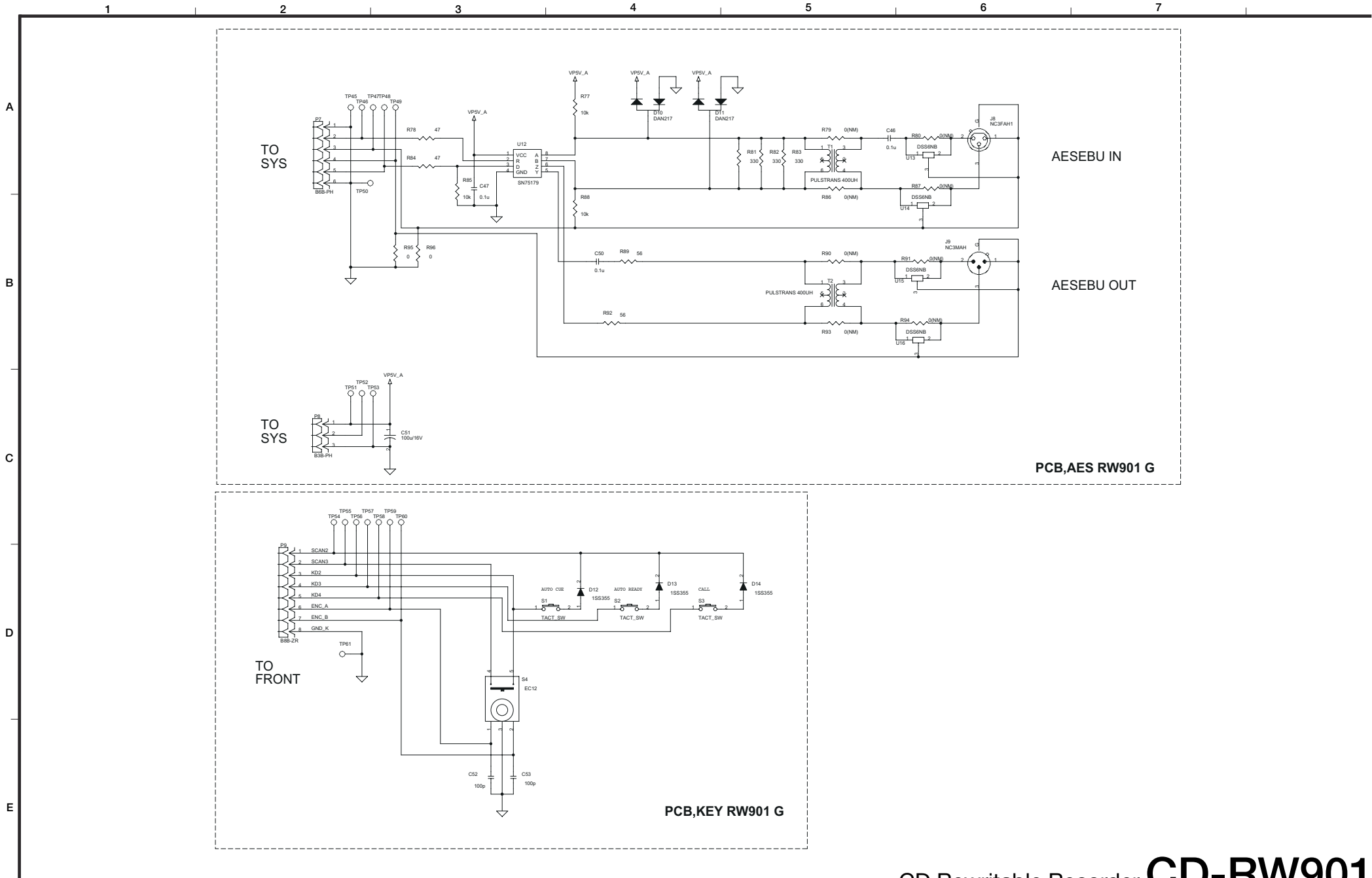

# CD-RW901 Wiring Diagram

