

CD-X1700

# TASCAM

TEAC Professional Division

## SERVICE MANUAL

# CD-X1500 & CD-X1700

## DUAL CD PLAYER



### CONTENTS

1. SAFETY INFORMATION	2
2. SPECIFICATIONS	3
3. TEST MODE	5
4. EXPLODED VIEWS AND PARTS LIST	11
5. PCB BOARDS AND PARTS LIST	18
6. INCLUDED ACCESSORIES	36

### 目次

1. SAFETY INFORMATION	2
2. 仕様	3
3. テスト・モード	5
4. 分解図とパーツリスト	11
5. 基板図とパーツリスト	18
6. 付属品	36

### INSTRUCTIONS FOR SERVICE PERSONNEL

BEFORE RETURNING APPLIANCE TO THE CUSTOMER, MAKE LEAKAGE-CURRENT OR RESISTANCE MEASUREMENTS TO DETERMINE THAT EXPOSED PARTS ARE ACCEPTABLY INSULATED FROM THE SUPPLY CIRCUIT.

# 1. SEFTY INFOMATION

This product has been designed and manufactured according to FDA regulations "title 21, CFR, chapter 1, subchapter J, based on the Radiation Control for Health and Safety Act of 1968", and is classified as a class 1 laser product. There is no hazardous invisible laser radiation during operation because invisible laser radiation emitted inside of this product is completely confined in the protective housings.

The label required in this regulation is shown ①.

## ● CAUTION

USE OF CONTROLS OR ADJUSTMENT OR PERFORMANCE OF PROCEDURES OTHER THAN THOSE SPECIFIED HEREIN MAY RESULT IN HAZARDOUS RADIATION EXPOSURE.

① For U.S.A.

CERTIFICATION  
THIS PRODUCT COMPLIES WITH DHHS  
RULES 21 CFR SUBCHAPTER J APPLI  
CABLE AT DATE OF MANUFACTURE  
TEAC CORPORATION  
3072 NAKAGCHO, MUSASHINO-SHI, TOKYO, JAPAN  
MANUFACTURED

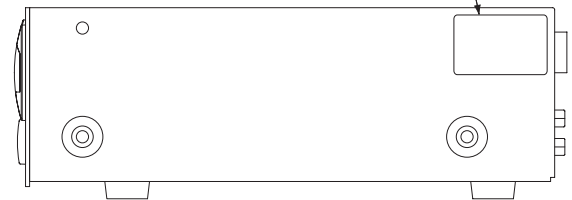

### Optical pickup:

Type :	KSS-213C
Manufacturer	: SONY Corporation
Laser output	: Less than 0.4 mW on the objective lens
Wavelength	: 760 - 800nm

## 2. SPECIFICATION

### 仕様

#### CD-X1500

Disc type:	8cm / 12cm CD
Number of channels:	2-channel
Resolution:	16-bit
Sampling frequency:	44.1kHz
Analog output:	RCA pin jack
Output impedance:	<1kohm
Maximum output level:	+6dBV
Digital output:	Coaxial
Format:	IEC60958 Type II
Voltage requirements	
USA/Canada:	120V AC, 60Hz
UK/Europe:	230V AC, 50Hz
Australia:	240V AV, 50Hz
Power consumption:	27W
Dimensions (W x H x D mm)	
Main unit:	482 x 94 x 272
Remote control unit:	482 x 88 x 83
Weight	
Main unit:	5.7kg
Remote control unit:	1.8kg

#### CD-X1500

使用ディスク	8cm / 12cm CD
チャンネル数	2チャンネル
量子化ビット数	16ビット
サンプリング周波数	44.1kHz
アナログ出力	RCAピン
出力インピーダンス	1kΩ以下
最大出力レベル	+6dBV
デジタル出力	Coaxial
フォーマット	IEC60958 Type II
電源	100V AC, 50-60Hz
消費電力	27 W
外形寸法 (W x H x D mm)	
本体	482 x 94 x 272
リモートコントローラー	482 x 88 x 83
質量	
本体	5.7 kg
リモートコントローラー	1.8 kg

The following values are applicable when key and tempo values are set to 0.

以下の性能はキーおよびテンポが0%のときのものです。

Frequency response:	20 – 20kHz, +0.5/-1.0dB
Dynamic range:	>95dB
S/N ratio:	>95dB
Total harmonic distortion:	<0.01%

周波数特性	20 – 20kHz, +0.5/-1.0dB
ダイナミックレンジ	95dB以上
S/N比	95dB以上
歪み率	0.01%以下

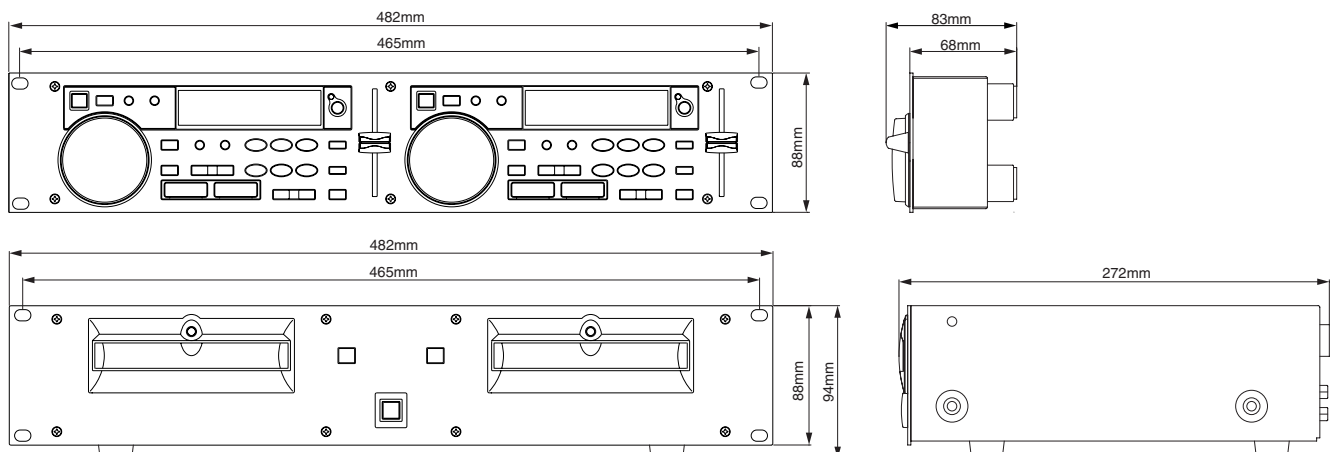

**CD-X1700**

Disc type:	8cm / 12cm CD
Number of channels:	2-channel
Resolution:	16-bit
Sampling frequency:	44.1kHz
Analog output:	RCA pin jack
Output impedance:	<1kohm
Maximum output level:	+6dBV
Digital output:	Coaxial
Format:	IEC60958 Type II
Voltage requirements	
USA/Canada:	120V AC, 60Hz
UK/Europe:	230V AC, 50Hz
Australia:	240V AV, 50Hz
Power consumption:	30W
Dimensions (W x H x D mm)	
Main unit:	482 x 94 x 272
Remote control unit:	482 x 132 x 83
Weight	
Main unit:	5.7kg
Remote control unit:	2.5kg

**CD-X1700**

使用ディスク	8cm / 12cm CD
チャンネル数	2チャンネル
量子化ビット数	16ビット
サンプリング周波数	44.1kHz
アナログ出力	RCAピン
出力インピーダンス	1kΩ以下
最大出力レベル	+6dBV
デジタル出力	Coaxial
フォーマット	IEC60958 Type II
電源	100V AC, 50-60Hz
消費電力	30W
外形寸法 (W x H x D mm)	
本体	482 x 94 x 272
リモートコントローラー	482 x 132 x 83
質量	
本体	5.7kg
リモートコントローラー	2.5kg

The following values are applicable when key and tempo values are set to 0.

以下の性能はキーおよびテンポが0%のときのものです。

Frequency response:	20 – 20kHz, +0.5/-1.0dB
Dynamic range:	>95dB
S/N ratio:	>95dB
Total harmonic distortion:	<0.01%

周波数特性	20 – 20kHz, +0.5/-1.0dB
ダイナミックレンジ	95dB以上
S/N比	95dB以上
歪み率	0.01%以下

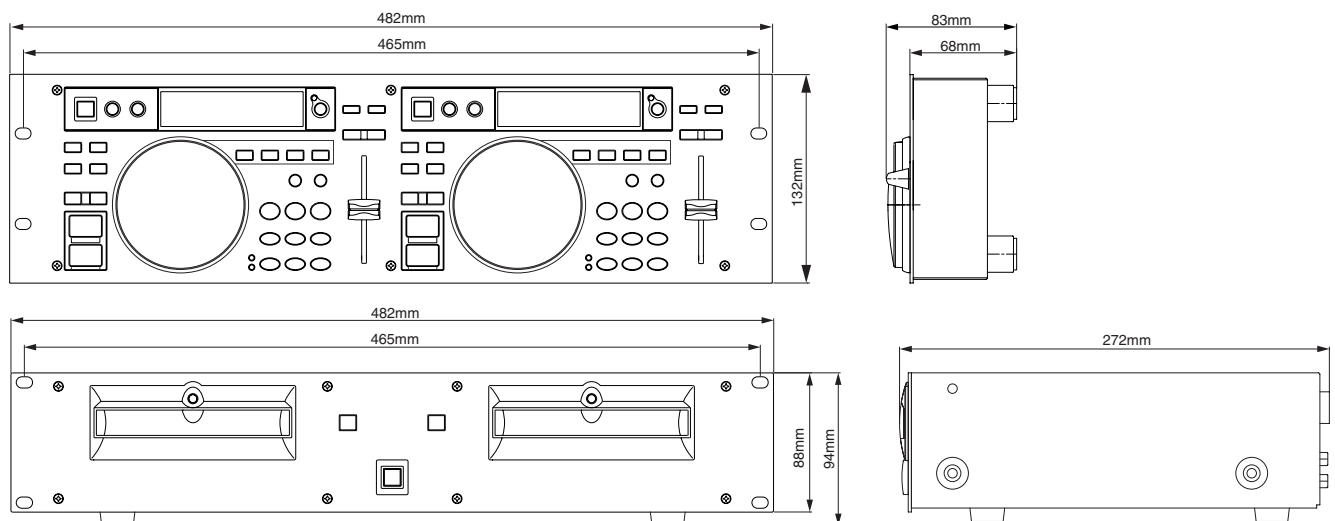

## 3. TEST MODE

### テストモード

#### 3-1. Test Mode

The 2488 has a test mode feature, allowing you to check for the correctness of the LED, volume control, MIDI, and TG operations.

##### 1) Shifting to Test Mode

With the tray opened, pressing LOOP A+B+TIME/ENTER gets the unit shifted in the test mode, as confirmed by "CD TEST" shown in the LCD display. This display goes out when the tray closes.

Once having run in test mode, the unit exits this mode only when you turn it off.

#### 3-1. テストモード

テストモードは、CDの制御の状態を設計時、サービス時等に確認することを目的としています。

##### 1) テストモードの入り方

トレーオープン状態で、LOOPのA + B + TIME/ENTERを押すとテストモードに入り、LCDに "CD TEST" 表示をします。トレーが閉まると表示は消えます。

一旦テストモードに入った後は、本体の電源をOFFしないとテストモードは解除できません。

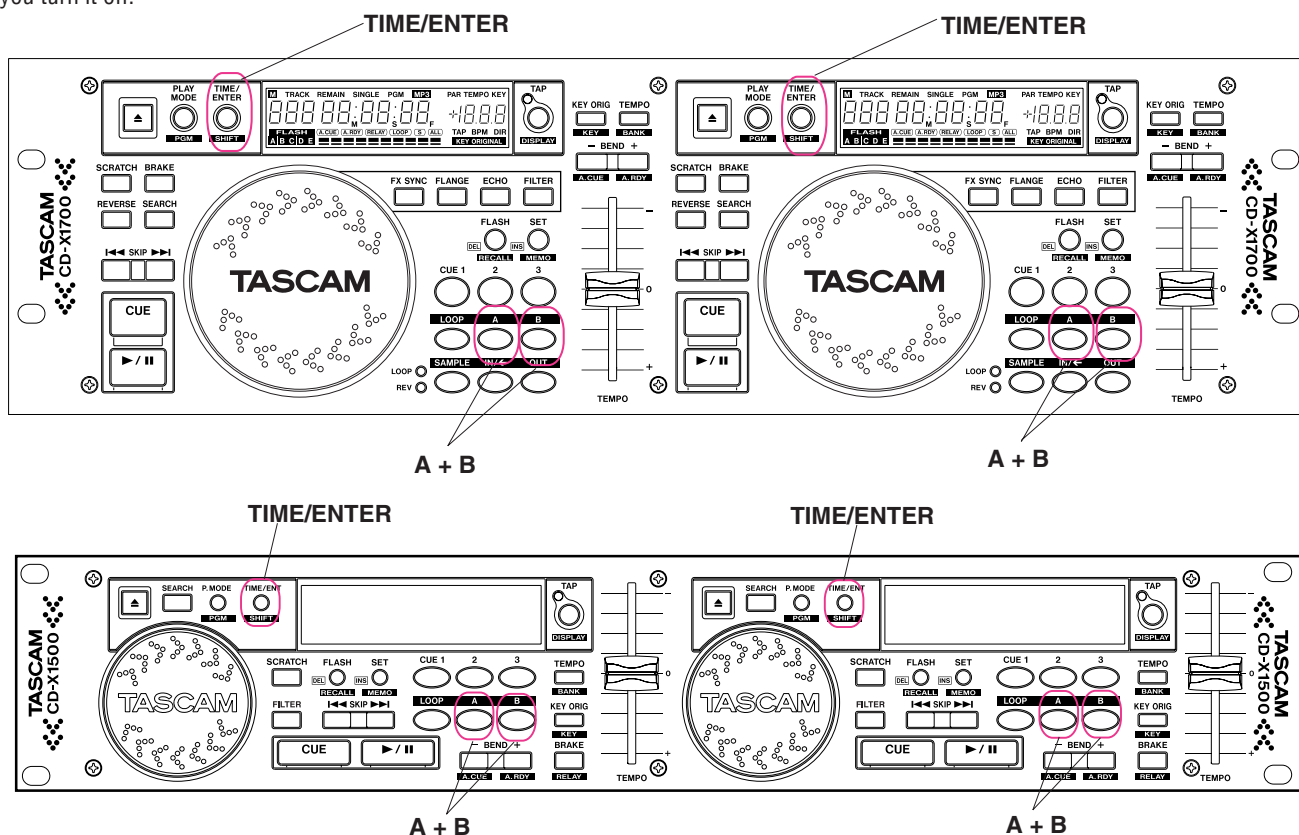

##### 2) Operation keys and their functions

「TIMER/ENTER」 : selects the play time display mode.

Banks A to E are assigned as follows:

- A: total play time
- B: Auto gain of tracking, thread, and focus
- C: C1 and C2 error rates
- D: Jitters, RF signal
- E: Offset

「PLAY MODE」 : switches CLV-N play speed between 1x and 2x.

- SINGLE OFF: 2x
- SINGLE ON: 1x

When in the Test mode, OPEN, CLOSE, PLAY/READY, FF, REW, and SKIP are available and all other keys are not available.

##### 2) 操作KEYとその機能

「TIME/ENTER」 : 演奏時間の表示モード切り替え

表示モードは、BANK A,B,C,D,Eで示す

- BANK A トータル演奏時間
- B トラッキング、スレッド、フォーカスのオートゲイン値
- C C1,C2エラーレート値
- D ジッター値、RF信号
- E オフセット調整値

「PLAY MODE」 : 1, 2倍速のCLV-N再生の切り替え

- SINGLE OFF 2倍速
- SINGLE ON 1倍速

テストモードに入るとOPEN, CLOSE, PLAY/READY, FF, REW, SKIPの各KEYは有効、その他KEYは無効になります。

### 3-2. Controller's exclusive test mode

The controller provides test functions focused on the microcomputer, which are accessible by pressing a combination of keys. The test functions include version number display, lighting up of all LCD segments, key-in check, TEMPO slider check.

\* Some of the test functions are not available on FRONT ucon Version 1.00. Fixed on Version 1.10 and above.

### 3-2. コントローラ単体テストモード

コントローラでは、KEYの多重押しによりマイコン単独のTEST機能が動作します。

TEST機能には、バージョン表示、LCD全表示、KEY入力CHECK、TEMPO VR CHECKの機能があります。

\* FRONT ucon Ver1.00で非対応の部分有り。Ver.1.10以降は対応済み。

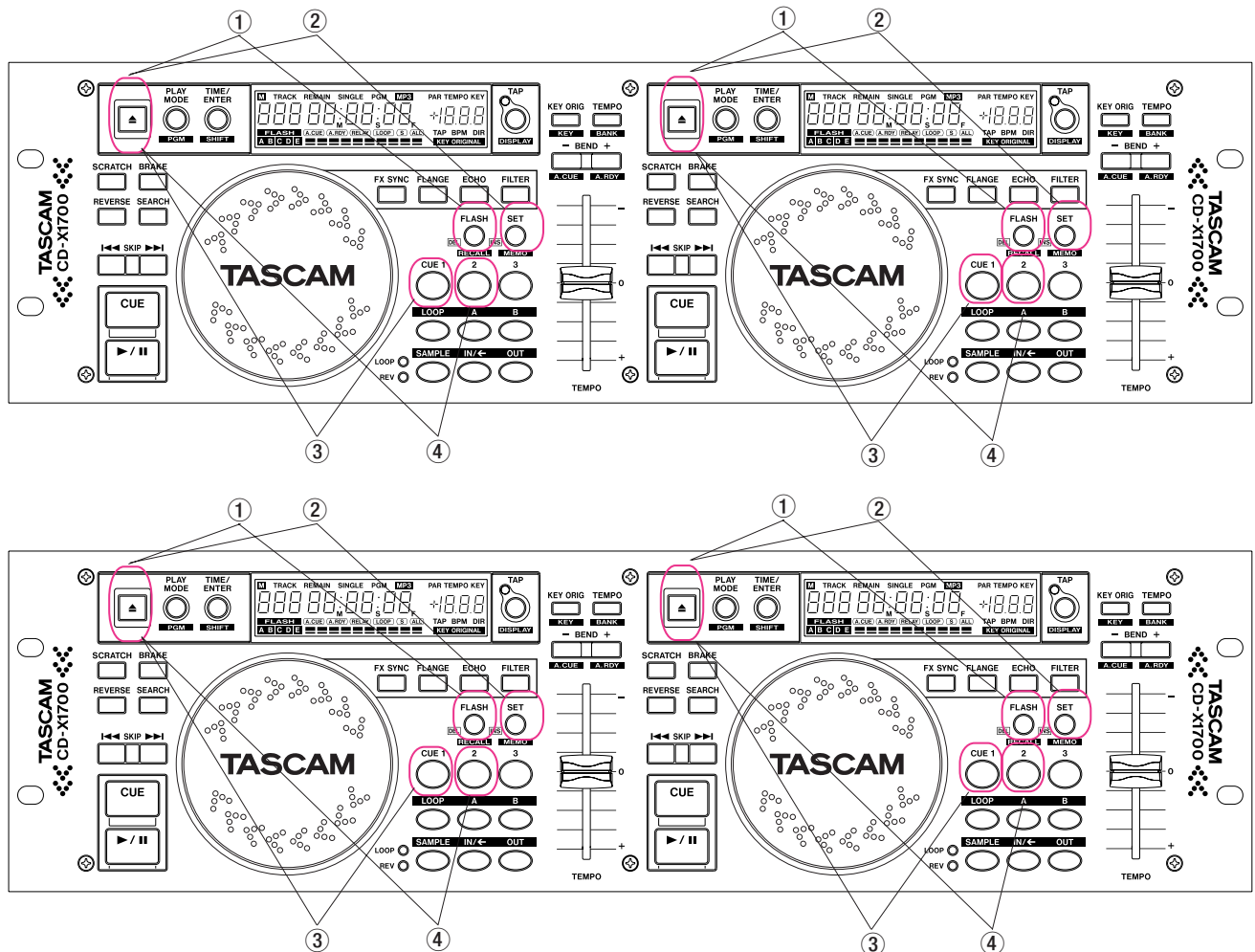

#### 1) Getting a test function started

Holding down a combination of keys (specified below) and switching on power to the unit activates a corresponding test function.

Once after a test function has started up, you can switch between test functions by pressing combinations of keys.

- |  |                  |
|--|------------------|
| (1) Microcomputer program version number : | OPEN/CLOSE+FLASH |
| (2) Lighting up all LCD segments:          | OPEN/CLOSE+SET   |
| (3) Key-in check:                          | OPEN/CLOSE+CUE1  |
| (4) TEMPO slider check:                    | OPEN/CLOSE+CUE2  |

#### 1) TEST機能の起動

下記のKEY を押しながら、電源を入れます。

いずれかのTEST機能が起動した後は、下記組み合わせのKEYで機能を切り替える事が出来ます。

- |                      |                    |
|----------------------|--------------------|
| (1)マイコンプログラムのバージョン表示 | OPEN/CLOSE + FLASH |
| (2)LCD全表示            | OPEN/CLOSE + SET   |
| (3)KEY入力 CHECK       | OPEN/CLOSE + CUE1  |
| (4)TEMPO VR CHECK    | OPEN/CLOSE + CUE2  |

## 2) Test functions explained

### (1) Microcomputer program version number

When pressing OPEN/CLOSE+FLASH, data from the main MPU to the LCD are ignored and the display shows the microcomputer version number.

### (2) Lighting up all LCD segments and LEDs

When pressing OPEN/CLOSE+SET, data from the main MPU to the LCD are ignored and all LEDs and all LCD segments light up. Then, pressing PLAY MODE gets COMs (1-4) in the LCD lit in sequence (on both the decks), and thereafter the LCD segments light up alternating between the odd- and even-numbered segments.

### (3) Key-in check

When pressing OPEN/CLOSE+CUE1, a number assigned to the key pressed is displayed in the LCD on the corresponding deck. (The associated LED also lights up.)

In process of key-in check, pressing a key does not get key data sent to the main MPU.

### (4) Checking TEMPO slider

When pressing OPEN/CLOSE+CUE2, data from the main MPU to the LCD are ignored and analog data coming from the A/D converter are displayed in the LCD as they are.

DECK1XXXX (0-1023)

DECK2XXXX (0-1023)

## 2) 各TEST機能

### (1)マイコンプログラムのバージョン表示

OPEN/CLOSE + FLASHが押されると、メインMPUからの表示データを無視し、LCDにマイコンプログラムのバージョンNOを表示します。

セグメントの文字を追加します

### (2)LCD/LED 全点灯

OPEN/CLOSE + SETが押されると、メインMPUからの表示データを無視し、LCD/LEDを全表示します。

PLAY MODE KEYが押されるまで全表示を続けKEYが押されると、LCDのCOM (1-4) が1個ずつ順番に点灯します (両デッキ)。その後LCDのセグメント端子の奇数番号と偶数番号のセグメントが交互に点灯します。

### (3)KEY入力 CHECK

OPEN/CLOSE + CUE1が押されると、押されたKEYに割り振られた番号をDECK1側ならDECK1のLCDへ、DECK2側ならDECK2のLCDへ表示します。(KEYに合わせて、LEDも表示する) KEY入力CHECK動作中は、KEYが押されてもKEYデータをメインMPUへ送信しません。

### (4)TEMPO VRのCHECK

OPEN/CLOSE+CUE2が押されると、メインMPUから送られてくる表示データを無視してLCDへA/Dから入力したアナログデータをそのまま表示します。

DECK1 XXXX( 0~1023)

DECK2 XXXX( 0~1023)

### 3-3. Display of Mechanical System's Total Operating Time

1. With the tray opened, holding down PLAY MODE+FLASH and pressing TIME/ENTER gets the total operating time of the mechanical system displayed in the LCD display, expressed in hours, as "\*\*\*\*:\*\*\*\*". You can get it displayed while you hold down PLAY MODE+FLASH.

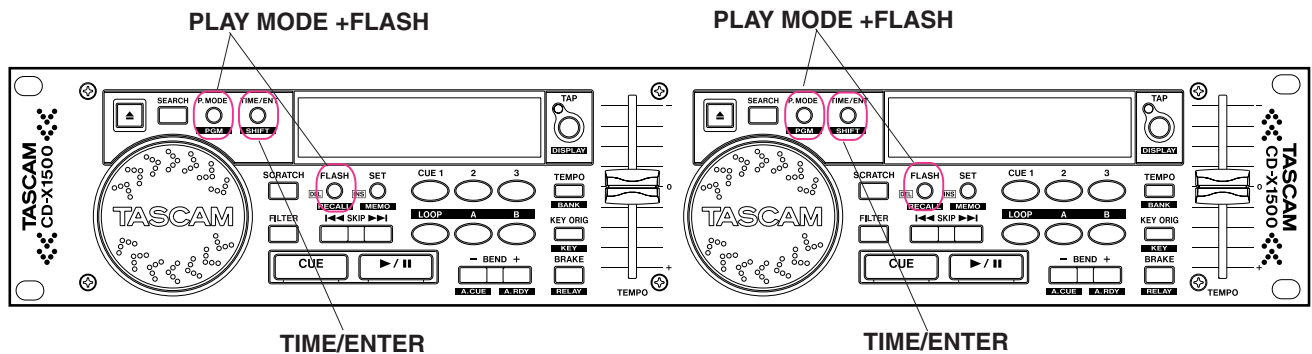
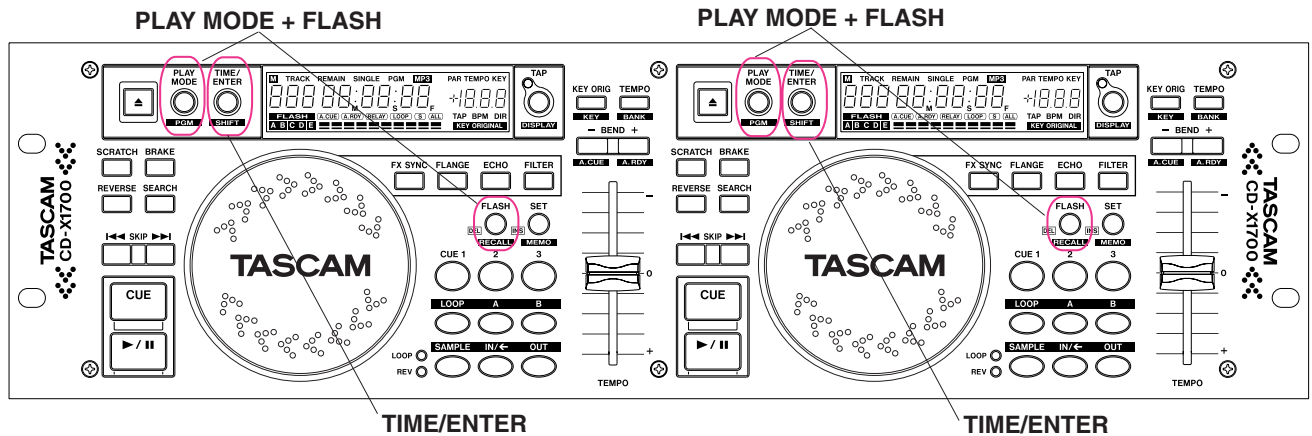

2. How to reset the time counts  
While the total operating time is displayed, press TIME/ENTER again and the display reads "SURE". Pressing TIME/ENTER once more gets "SURE" gone out and the total time counts are reset.

### 3-3. メカ積算時間の表示機能

1. トレーオープン状態で、PLAY MODE+FLASHを押しながらTIME/ENTERを押すとLCDにメカ積算時間が "\*\*\*\*:\*\*\*\*" で表示されます。PLAY MODE+FLASHを押し続けている間は表示されます。(単位は時間です)

- 2 積算時間のリセット方法  
上記のメカ積算時間の表示中に再度TIME/ENTERを押すと "SURE" が表示されます。そのままの状態から、再度TIME/ENTERを押すと "SURE" が消え、メカ積算時間がリセットされます。

## 3-4. Restoring to Factory Default Settings

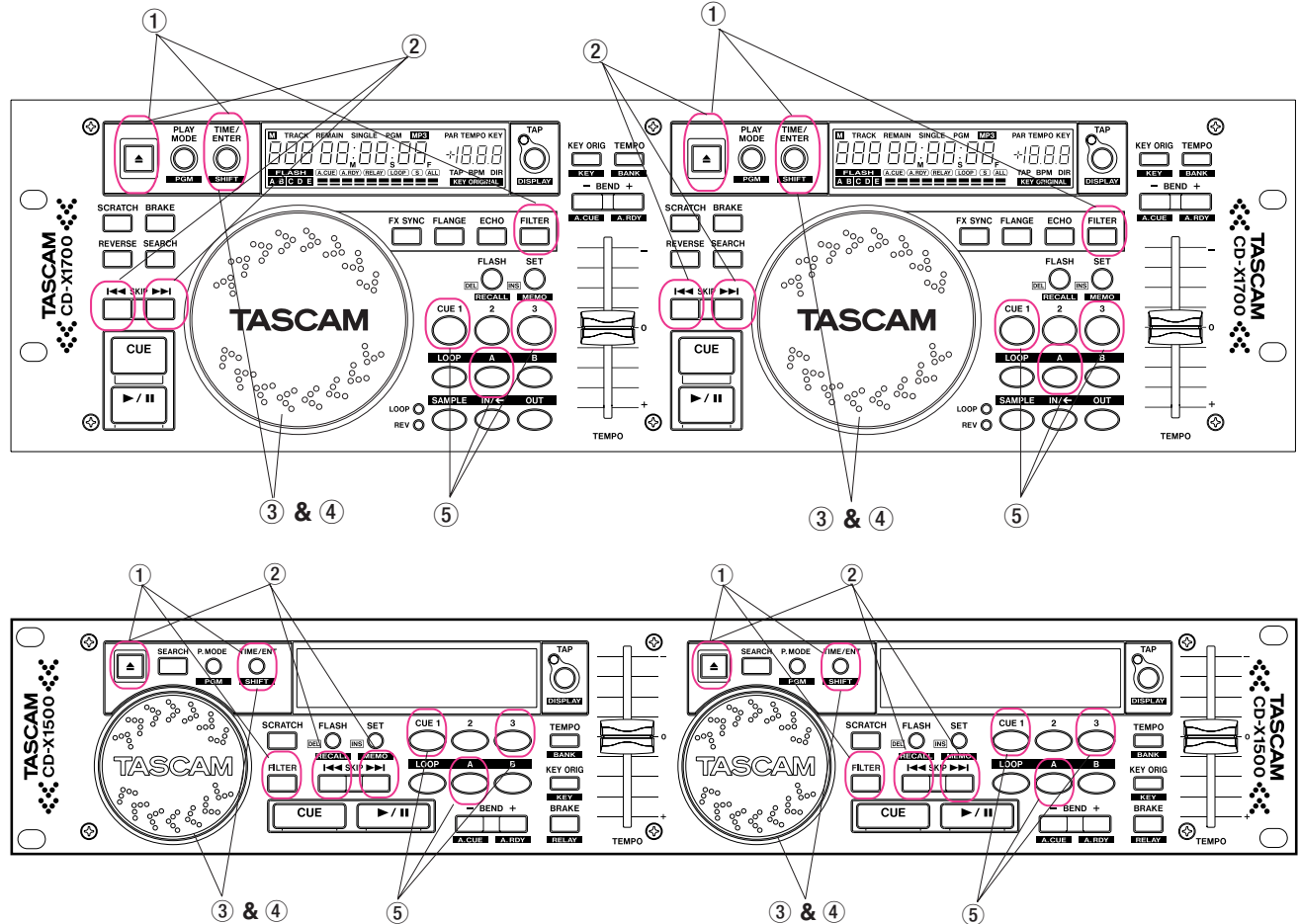

## 3-4. 工場出荷状態の設定

## 1) TEMPO slider

- (1) Set the TEMPO slider to the center "click" position (i.e., to 0%).
- (2) With the tray closed, hold down OPEN/CLOSE and TIME/ENTER and press FILTER and the TEMP display in the LCD reads "0. 0" and the procedure is complete.

## 2) Servo constant

- (1) Set MCD-111 to the tray.
- (2) Hold down FWD SKIP+REV SKIP and press OPEN/CLOSE and the LCD display reads "ADJUST 1".
- (3) The servo constant is automatically adjusted to match the CD drive in use and stored in EP ROM.

## 3) Presets

- (1) Hold down SHIFT and rotate the JOG dial to select No6 (for X1500) or No7 (for X1700) and the LCD display reads "F PrE", the presets being reset.
- (2) Press ENTER and "SURE" is displayed.
- (3) Press ENTER to complete the procedure.

## 4) Clearing all memories

- (1) Hold down SHIFT and rotate the JOG dial to select No7 (for X1500) or No8 (for X1700) and the LCD display reads "ALL CLR".
- (2) Press ENTER and the "SURE" is displayed.
- (3) Press ENTER to complete the procedure.

## 1) TEMPO VR 設定

- (1) TEMPO VRをセンタークリック位置にセットします (0%)。
- (2) TRAY CLOSE状態で、OPEN/CLOSEとTIME/ENTERを押しながらFILTERを押すとLCDのTEMPに "0. 0" を表示し設定が終了します。

## 2) サーボ定数の設定

- (1) MCD-111をトレーにセットします。
- (2) FWD SKIP + REV SKIP を押しながら、OPEN/CLOSEを押すとLCDに "ADJUST1" を表示します。
- (3) サーボ定数の自動調整が行われ、調整した値がEP ROMに記憶されます。

## 3) プリセットの初期化

- (1) SHIFT を押しながら JOGを回しNo6(X1500) 又は No7(X1700)を選択すると、LCDに "F PrE" を表示し初期化します。
- (2) ENTER を押すと、"SURE" を表示します。
- (3) ENTERを押して終了します。

## 4) メモリーオールクリアー

- (1) SHIFT を押しながら JOGを回しNo7(X1500) 又は No8(X1700)を選択すると、LCDに "ALL CLR" を表示します。
- (2) ENTER を押すと、"SURE" を表示します。
- (3) ENTERを押して終了します。

## PARTS LIST SECTION

### NOTES

- PC boards shown are viewed from parts side.
- Parts marked with \* require longer delivery time.
- The parts with no reference number or no parts number in the exploded views are not supplied.
- As regards the resistors and capacitors, refer to the circuit diagrams contained in this manual.
- △ Parts marked with this sign are safety critical components. They must be replaced with identical components - refer to the appropriate parts list and ensure exact replacement.
- Parts of [ ] mark can be used only with the version designated.  
[J]: JAPAN [US/C]: U.S.A./CANADA [K]: KOREA [E]: EUROPE  
[UK]: U.K. [A]: AUSTRALIA

### 注 意

- プリント基板図は部品面を示しています。
- \*印の部品は納期が若干かかります。  
あらかじめご了承ください。
- 分解図に部番のない部品および品番のない部品は供給できません。
- 標準の抵抗、コンデンサーは省略してあります。  
回路図を参照してください。
- △印は安全重要部品です。  
交換する時は必ず指定の部品を使用してください。
- 仕向先  
[J]: JAPAN [US/C]: U.S.A./CANADA [K]: KOREA [E]: EUROPE  
[UK]: U.K. [A]: AUSTRALIA

# 4. EXPLODED VIEWS AND PARTS LIST

分解図とパーツリスト

## EXPLODED VIEW-1

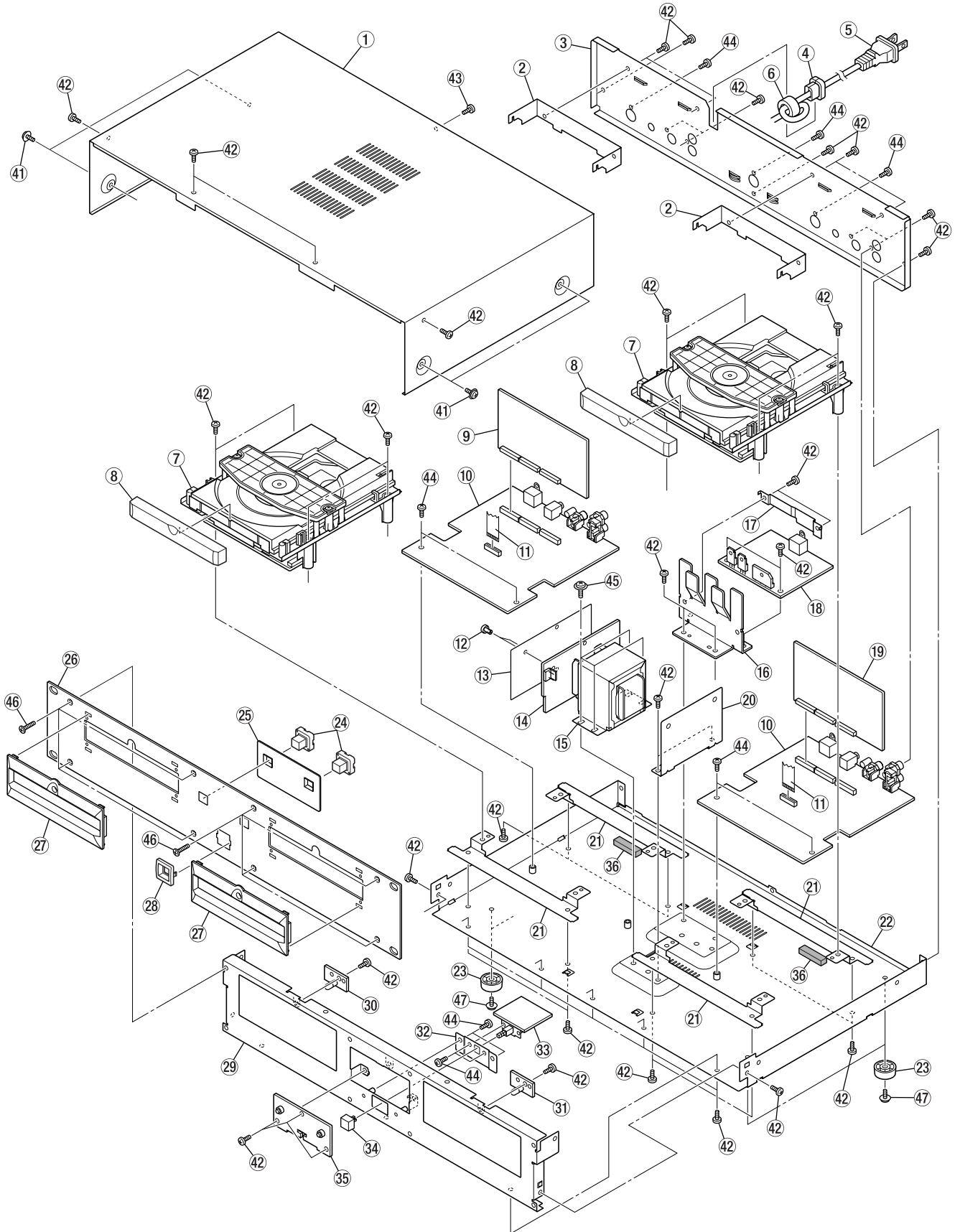

**EXPLODED VIEW-1**

REF.NO.	PARTS NO.	DESCRIPTION	REMARKS
1-01	M016624-00A	BONNET,P	
1-02	M016631-00A	ANGLE,PCB	
1-03	M016623-00A	REAR PANEL,1500P	
1-04	3M000880	BUSHING, #2271(CSA)	
1-05	3E002120	POWER CORD,JPN	
1-05	3E006330	POWER CORD KOREA	
1-05	3E009230	POWER CORD,UL/CSA SPEI	
1-05	3E000360	POWER CORD,AUS	
1-05	3E015210	POWER CORD,EUR	
1-05	3E000350	POWER CORD,UK	
1-06	3E002720	FER.CORE K5AT 18.3X10X10	
1-07	3M01296-00A	CD MECH ASSY WSL-2130CCM	
1-08	M016633-00A	PANEL,TRAY	
1-09	3E95743-00A	PCBA,DSP-L CD-X1500	
1-09	3E95743-20A	PCBA,DSP-L CD-X1700	
1-10	3E95735-00A	PCBA,MAIN CD-X1500	
1-11	3E03513-00A	FLAT CABLE 16P	
1-12	M013057-00A	RIVET,NYLON SR3-5.5	
1-13	M017432-00A	VINYL SHEET,INSULATED	
1-14		PCBA,TRANS CD-X1500	PCB ASSY,GATHER(D) (Refer to page 19)
1-15	E008451-00A	TRANS,DM CD-X1500	
1-15	E008452-00A	TRANS,UL/GSA CD-X1500	
1-15	E008454-00A	TRANS,AUS CD-X1500	
1-15	E008453-00A	TRANS,EUR CD-X1500	
1-16	M016639-00A	HEATSINK,P	
1-17	M017423-00A	PLATE,NUT	
1-18		PCBA,POWER CD-X1500	PCB ASSY,GATHER(D) (Refer to page 19)
1-19	3E95743-10A	PCBA,DSP-R CD-X1500	
1-19	3E95743-30A	PCBA,DSP-R,CD-X1700	
1-20	M016630-00A	ANGLE,MECHA B	
1-21	M016629-00A	ANGLE,MECHA A	
1-22	M016625-00B	CHASSIS,MAIN P	
1-23	3M001950	FOOT,21MM	
1-24	M016638-00A	BUTTON,OPEN P	
1-25	M016636-00A	ESCUTCHEON,OPEN	
1-26	M016622-00A	FRONT PANEL,1500P	
1-27	M016634-00A	ESCUTCHEON,CD	
1-28	M016635-00A	ESCUTCHEON,POWER	
1-29	M016626-00A	CHASSIS,FRONT P	
1-30		PCBA,LED A CD-X1500	PCB ASSY,GATHER(D) (Refer to page 19)
1-31		PCBA,LED B CE-X1500	
1-32	M017408-00A	PLATE,POWER	
1-33		PCBA,SW CD-X1500	PCB ASSY,GATHER(D) (Refer to page 19)
1-34	M016637-00A	BUTTON,POWER	
1-35		PCBA,OPEN CD-X1500	PCB ASSY,GATHER(D) (Refer to page 19)
1-36	3M01619-00A	BONNET CUSHION	
1-41	3B00018-06A	SCREW,J, S M3X6 BLK	
1-42	3B00057-08B	SCREW,BPB M3X8 (BLK)	
1-42	3B00057-08B	SCREW,BPB M3X8 (BLK)	
1-42	3B00057-08B	SCREW,BPB M3X8 (BLK)	

**EXPLODED VIEW-1**

REF.NO.	PARTS NO.	DESCRIPTION	REMARKS
1-42	3B00057-08B	SCREW,BPB M3X8 (BLK)	
1-42	3B00057-08B	SCREW,BPB M3X8 (BLK)	
1-42	3B00057-08B	SCREW,BPB M3X8 (BLK)	
1-42	3B00057-08B	SCREW,BPB M3X8 (BLK)	
1-42	3B00057-08B	SCREW,BPB M3X8 (BLK)	
1-43	3B00038-08A	SCREW,VPCR M3X8 BLK	
1-44	3B00085-06A	SCREW,BPA M3X6(BLK)	
1-44	3B00085-06A	SCREW,BPA M3X6(BLK)	
1-44	3B00085-06A	SCREW,BPA M3X6(BLK)	
1-44	3B00085-06A	SCREW,BPA M3X6(BLK)	
1-44	3B00085-06A	SCREW,BPA M3X6(BLK)	
1-44	3B00057-08B	SCREW,BPB M3X8 (BLK)	
1-45	3B00054-08A	SCREW,BPB M4X8	
1-46	B001454-00A	SCREW D M3*10 BLACK	
1-47	3B00013-06A	SCREW,J, S M3X6	

EXPLODED VIEW-2

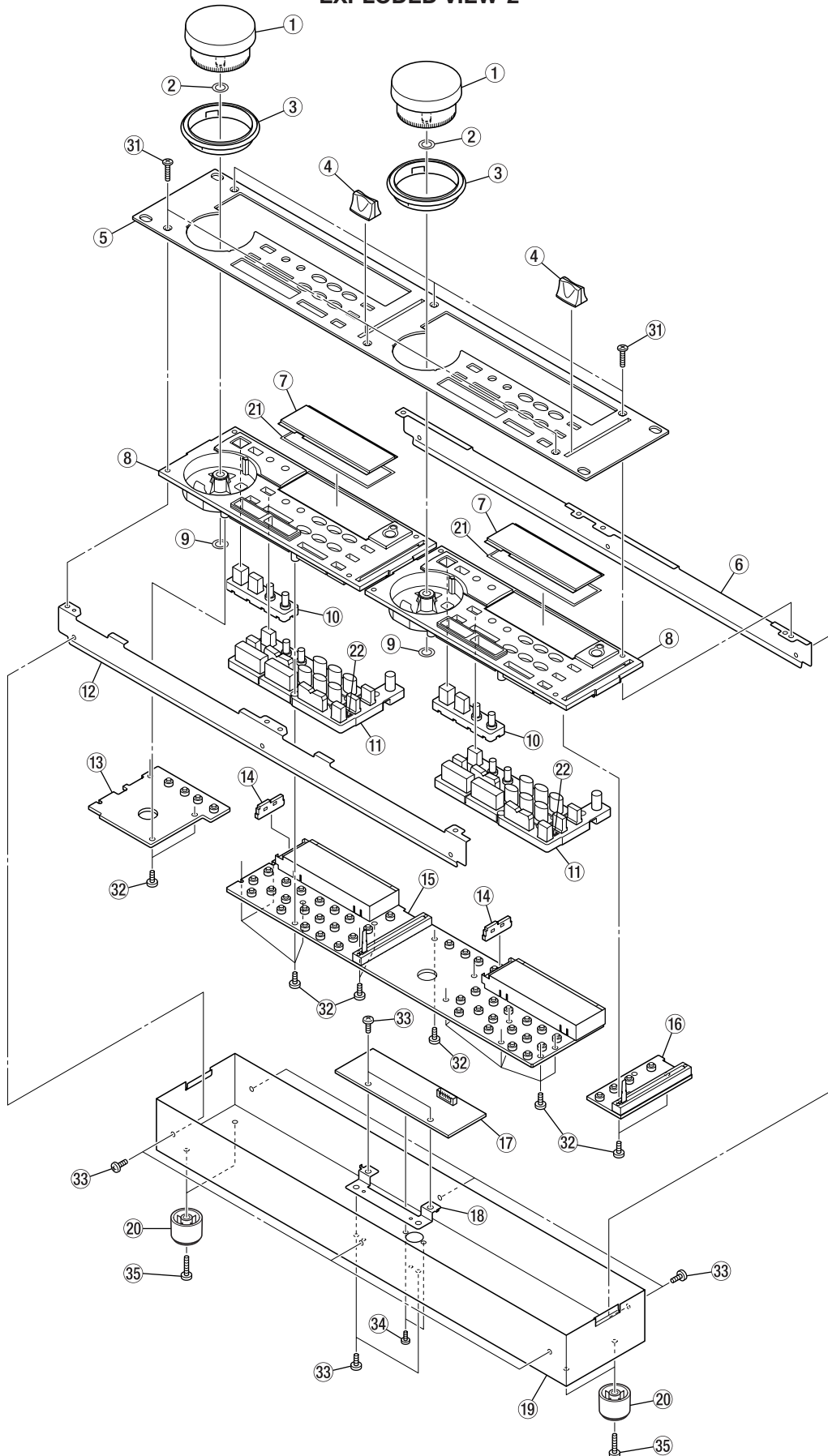

**EXPLODED VIEW-2**

REF.NO.	PARTS NO.	DESCRIPTION	REMARKS
2-01	M016615-00B	JOG ASSY,1500C	
2-02	57853060-00	@PLYLIDER,6*9*0.25T	
2-03	M016611-00A	RING,JOG 1500C	
2-04	3M02343-00A	KNOB VR	
2-05	M016605-00A	FRONT PANEL,1500C	
2-06	M016607-00A	ANGLE,A 1500C	
2-07	M018778-00A	WINDOW	
2-08	M016610-00B	ESCUTCHEON,1500C	
2-09	M018779-00A	WASHER,PLY 4*8*0.5CUT	
2-10	M016614-00A	BUTTON,B 1500C	
2-11	M016613-00A	BUTTON,A 1500C	
2-12	M016608-00A	ANGLE,B 1500C	
2-13		PCBA,L CD-X1500	PCB ASSY,GATHER(B) (Refer to page 24)
2-14		PCBA,LCD CD-X1500	PCB ASSY,GATHER(E) (Refer to page 25)
2-15		PCBA,PANEL CD-X1500	PCB ASSY,GATHER(A) (Refer to page 22)
2-16		PCBA,R CD-X1500	PCB ASSY,GATHER(B) (Refer to page 24)
2-17		PCBA,REAR CD-X1500	PCB ASSY,GATHER(B) (Refer to page 24)
2-18	M016609-00A	ANGLE,C 1500C	
2-19	M016606-00A	BONNET,1500C	
2-20	55046760-00	FOOT LEG 19L F500	
2-21	M018572-00A	CUSHION,WINDOW	
2-22	M018387-00A	VINYL SHEET,BUTTON	
2-31	B001454-00A	SCREW D M3*10 BLACK	
2-32	3B00008-08A	SCREW,BPP M3X8	
2-32	3B00008-08A	SCREW,BPP M3X8	
2-32	3B00008-08A	SCREW,BPP M3X8	
2-33	3B00057-08B	SCREW,BPB M3X8 (BLK)	
2-34	3B00047-08A	SCREW,BPP M2.6X8 (BLK)	
2-35	3B00013-20A	SCREW,J,S M3X20	

EXPLODED VIEW-3

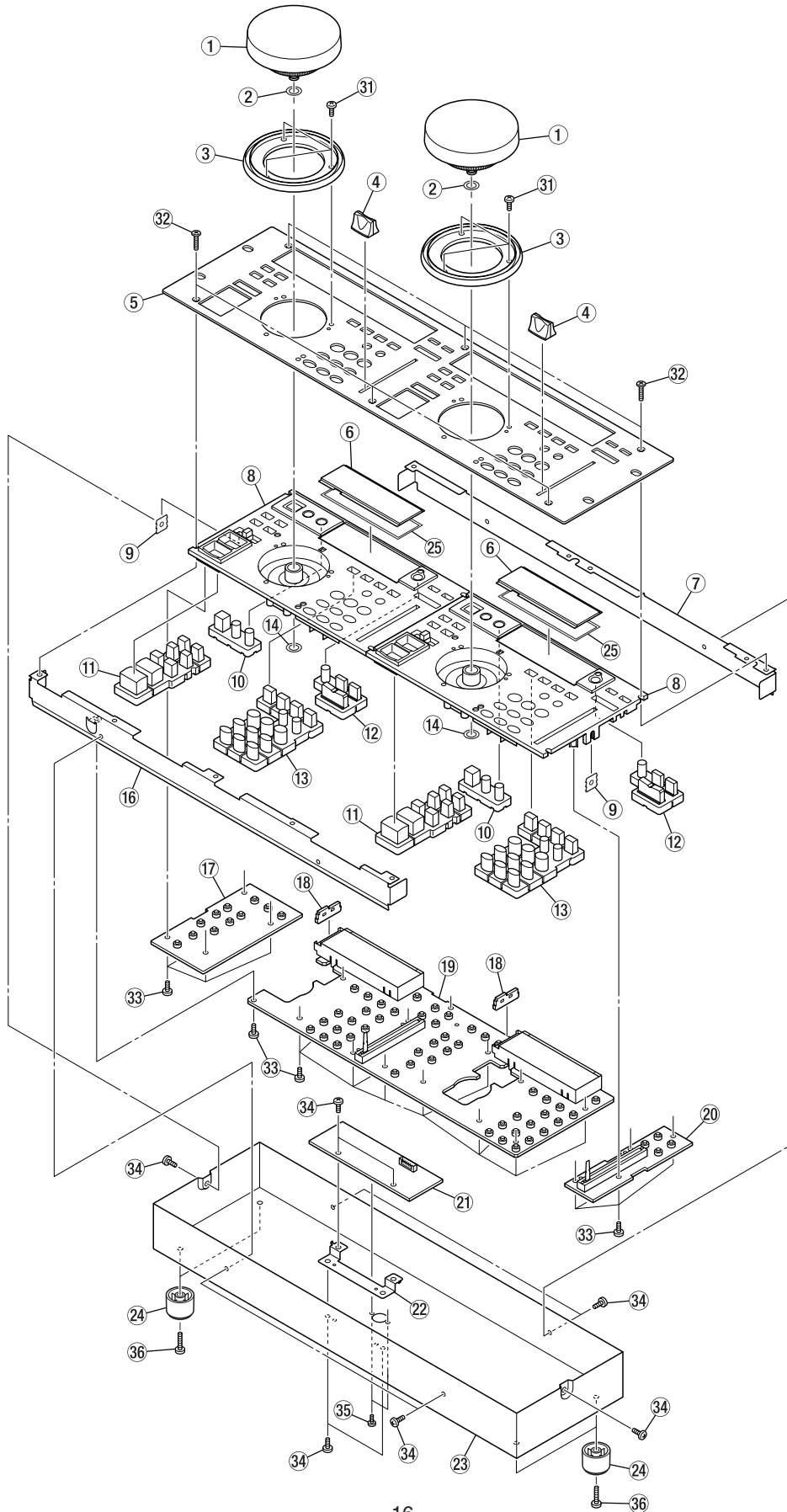

**EXPLODED VIEW-3**

REF.NO.	PARTS NO.	DESCRIPTION	REMARKS
3-01	M017790-00B	JOG ASSY,1700G	
3-02	3M02406-00A	PLYSLIDER,8*12*0.5	
3-03	M016646-00A	RING,JOG 1700C	
3-04	3M02343-00A	KNOB VR	
3-05	M016640-00A	FRONT PANEL,1700C	
3-06	M018778-00A	WINDOW	
3-07	M016642-00A	ANGLE,A 1700C	
3-08	M016645-00B	ESCUTCHEON,1700C	
3-09	M018008-00A	PLATE,NUT 1700C	
3-10	M017060-00A	BUTTON,D CD-X1700	
3-11	M016648-00A	BUTTON,B 1700C	
3-12	M017059-00A	BUTTON,C CD-X1700	
3-13	M016647-00A	BUTTON,A 1700C	
3-14	M018780-00A	WASHER,PLY 6*10*0.5CUT	
3-15			
3-16	M016643-00A	ANGLE,B 1700C	
3-17		PCB,L(G) CD-X1700	PCB ASSY,GATHER(G) (Refer to page 28)
3-18		PCBA,LCD,CD-X1700	PCB ASSY,GATHER(E) (Refer to page 25)
3-19	3E95827-00A	PCBA PANEL,CD-X1700	
3-20		PCB,R(G) CD-X1700	PCB ASSY,GATHER(G) (Refer to page 28)
3-21		PCB,REAR(G) CD-X1700	PCB ASSY,GATHER(G) (Refer to page 28)
3-22	M016644-00A	ANGLE,C 1700C	
3-23	M016641-00A	BONNET,1700C	
3-24	55046760-00	FOOT LEG 19L F500	
3-25	M018572-00A	CUSHION,WINDOW	
3-31	3B00008-12A	SCREW,BPP M3X12	
3-32	B001454-00A	SCREW D M3*10 BLACK	
3-33	3B00008-08A	SCREW,BPP M3X8	
3-33	3B00008-08A	SCREW,BPP M3X8	
3-33	3B00008-08A	SCREW,BPP M3X8	
3-34	3B00057-08B	SCREW,BPB M3X8 (BLK)	
3-35	3B00047-08A	SCREW,BPP M2.6X8 (BLK)	
3-36	3B00013-20A	SCREW,J,S M3X20	

# 5. PCB BOARDS AND PARTS LIST

基板図とパーツリスト

## MAIN PCB

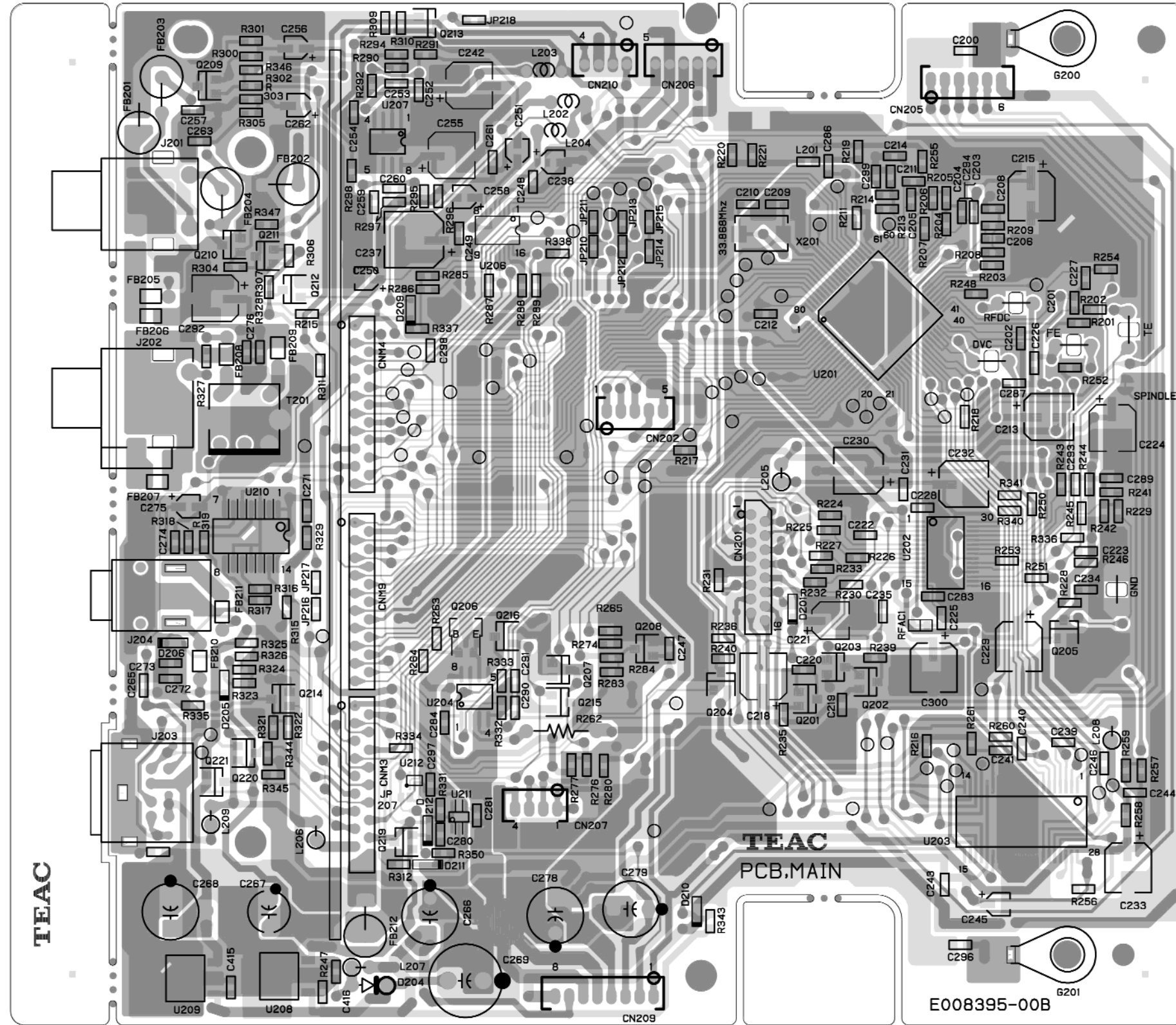

**GATHER PCB(D)** (PCB.POWER PCB.TRANS PCB.SW PCB.OPEN PCB.LED A PCB.LED B )

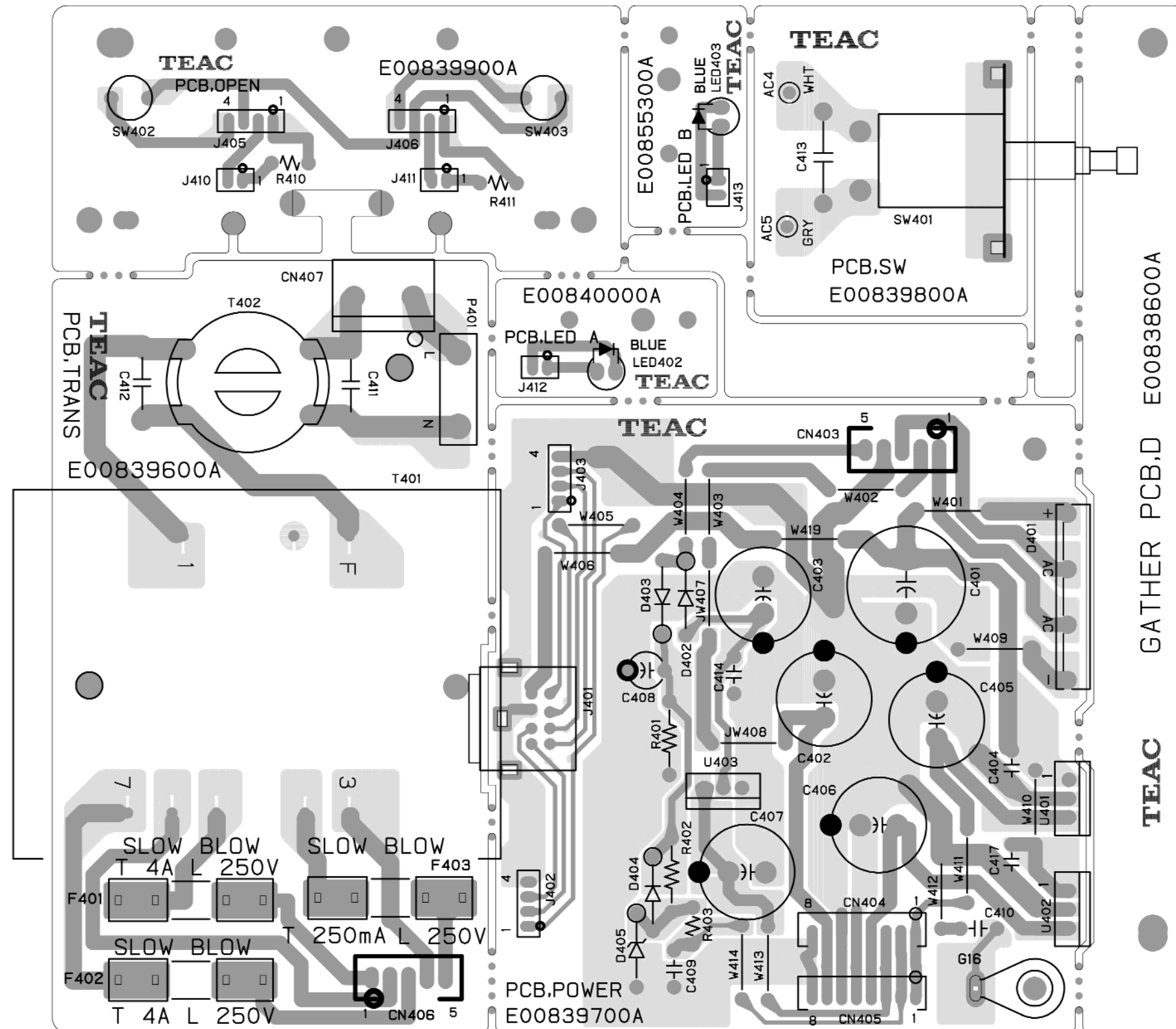



DSP PCB (DSP-L DSP-R) SIDE B

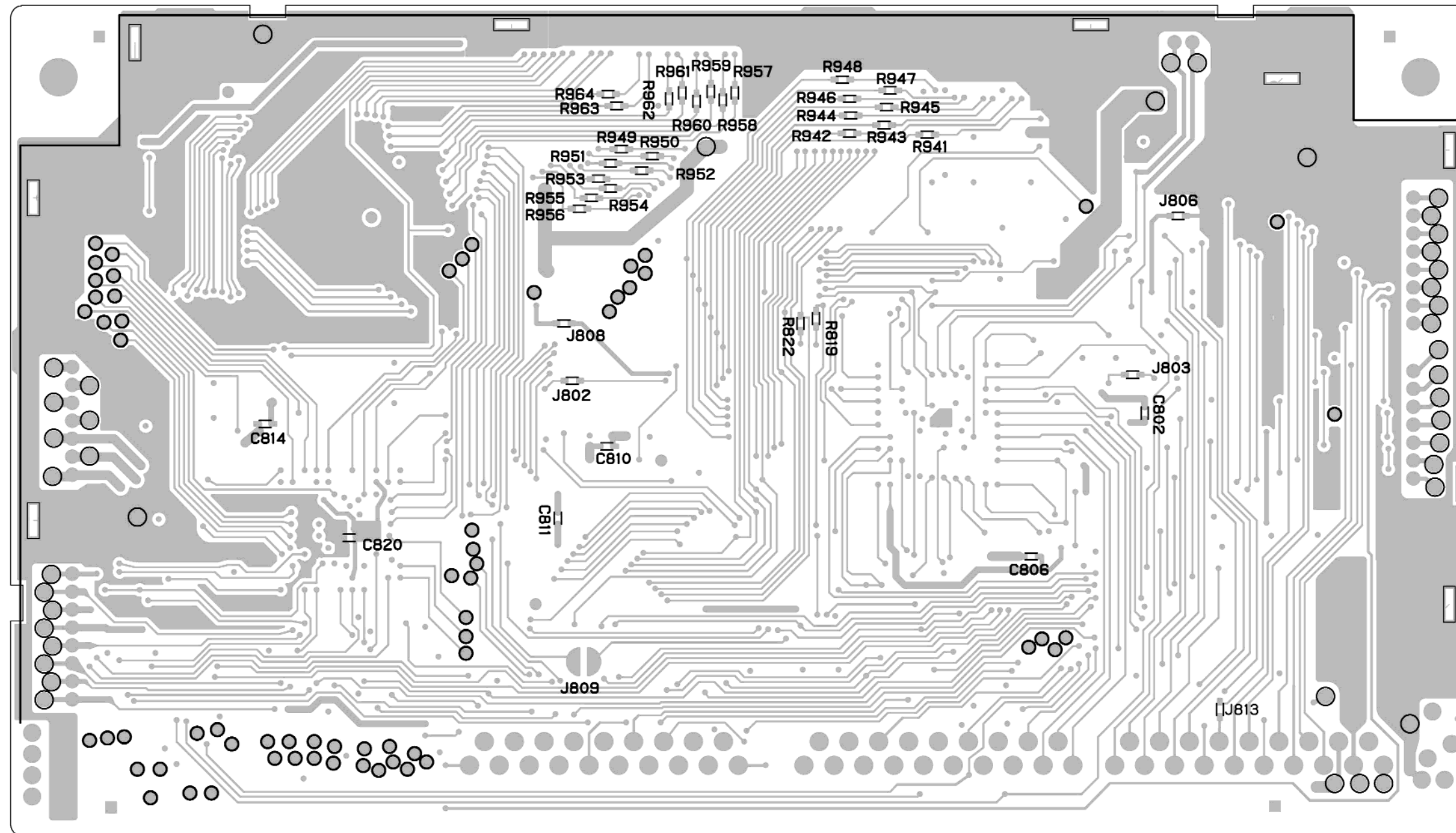

GATHER PCB(A) (PCB.PANEL CD-X1500) SIDE A

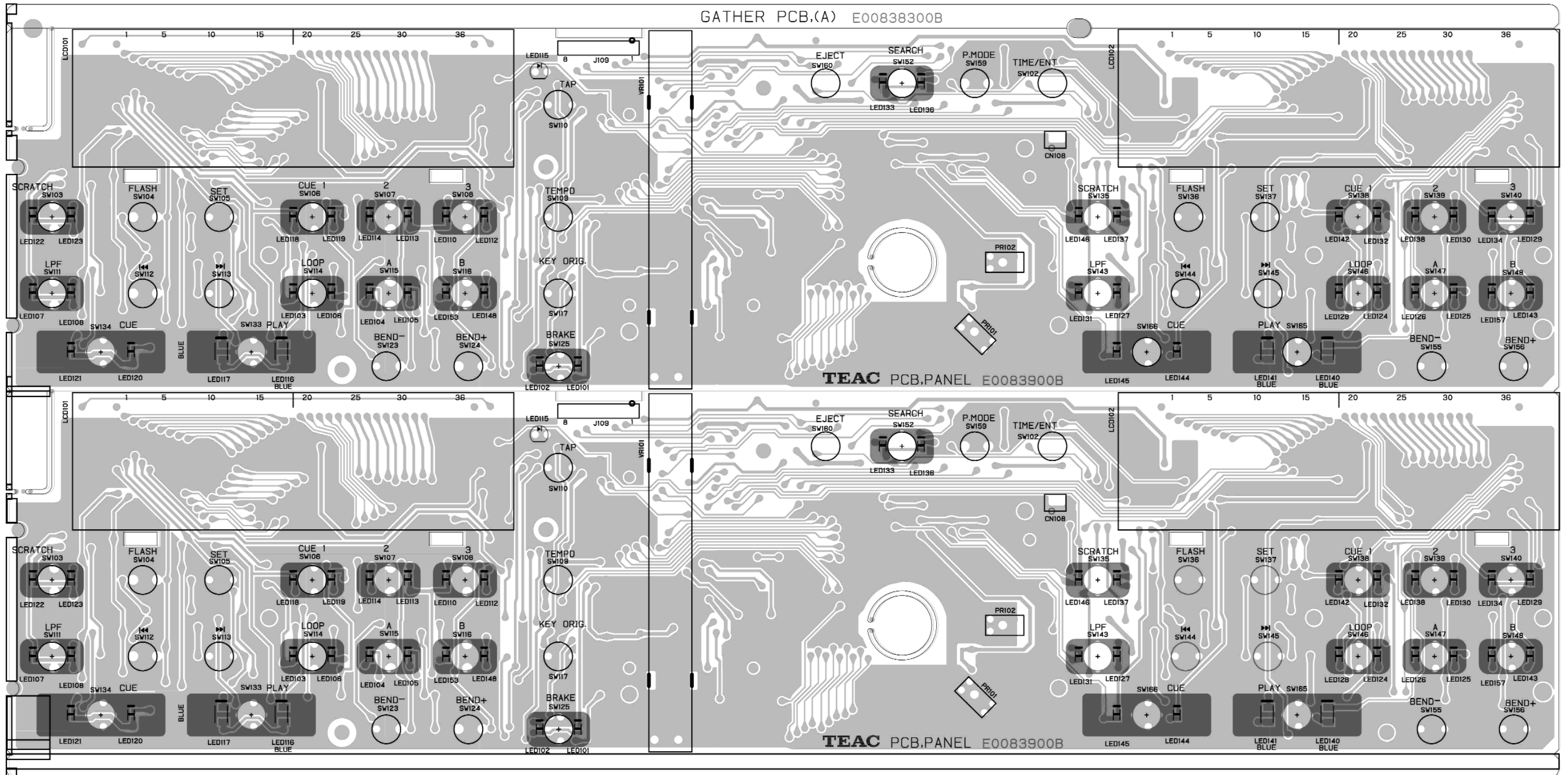



**GATHER PCB (B) ( PCB.REAR PCB.L PCB.R )**

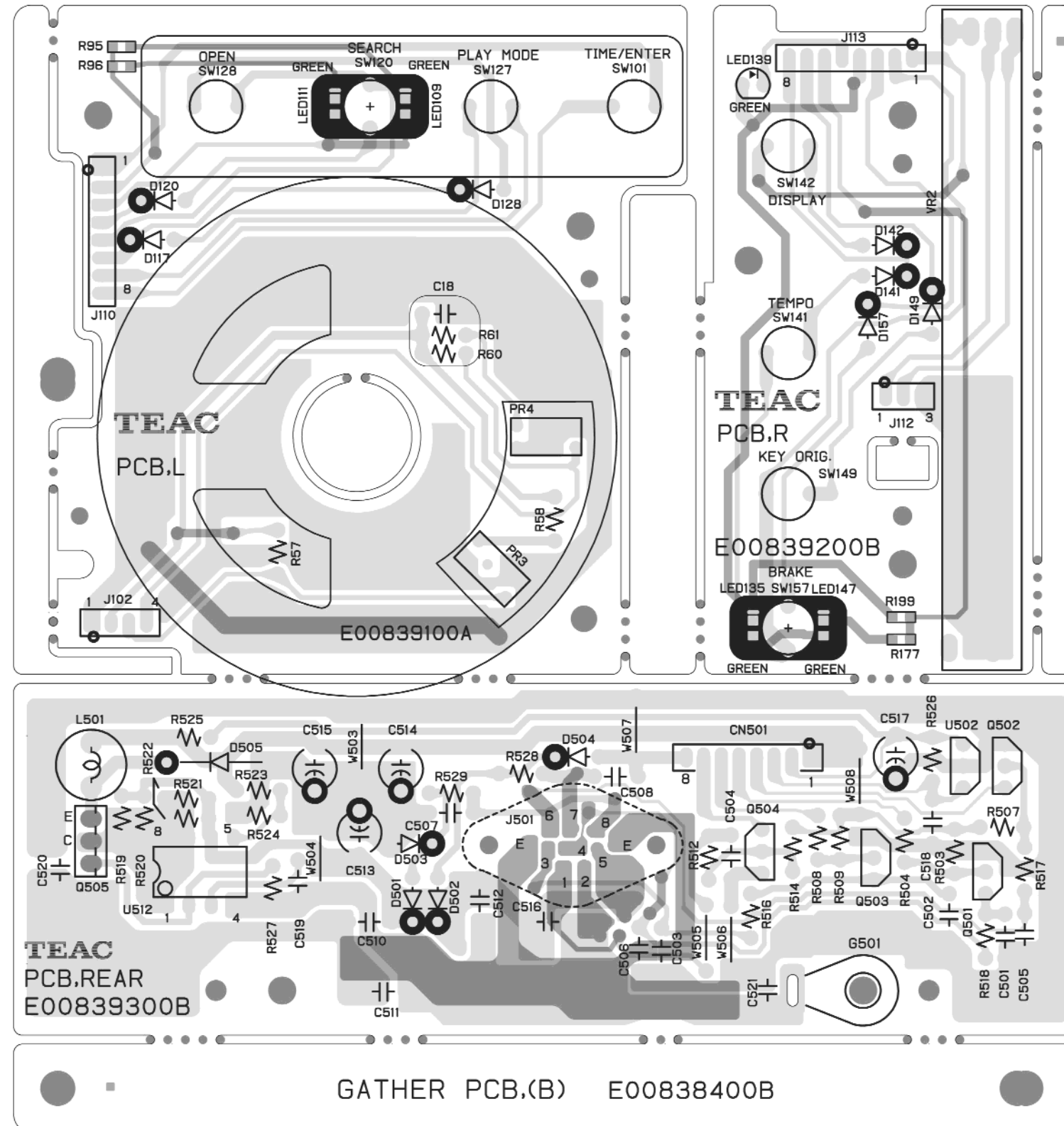

### GATHER PCB(E) ( PCB.LED )

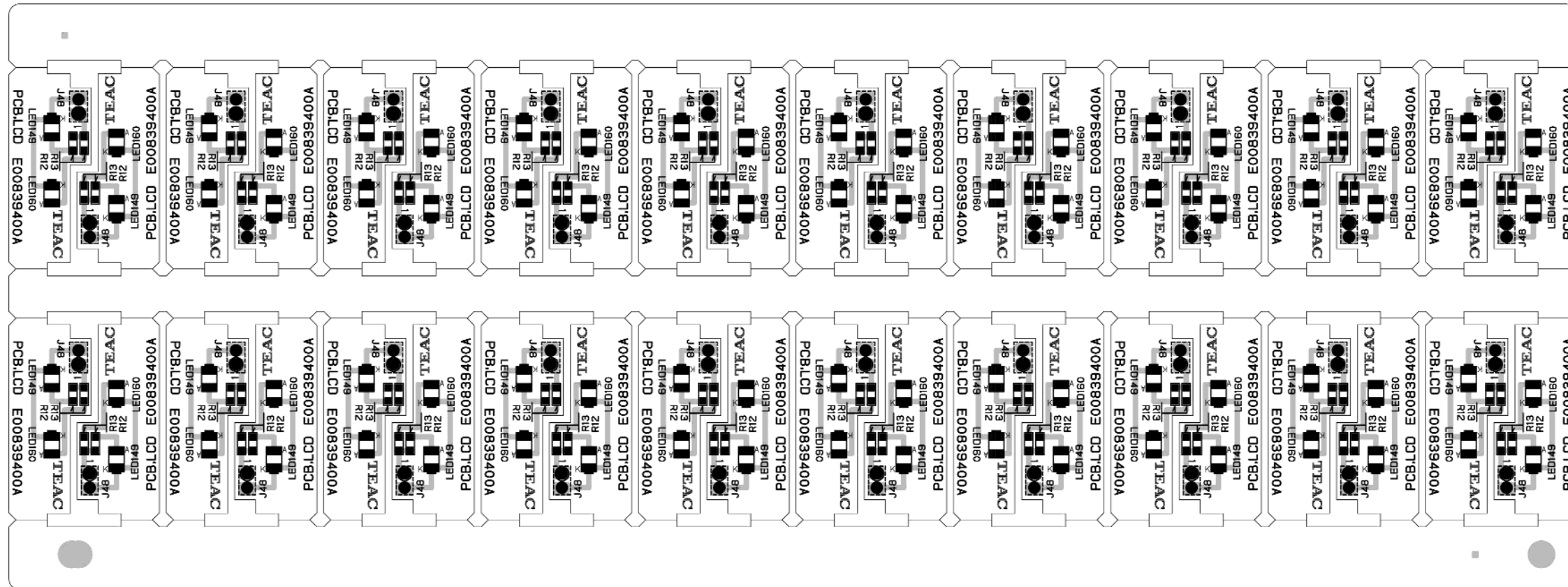

PCB PANEL.CD-X1700 SIDE A

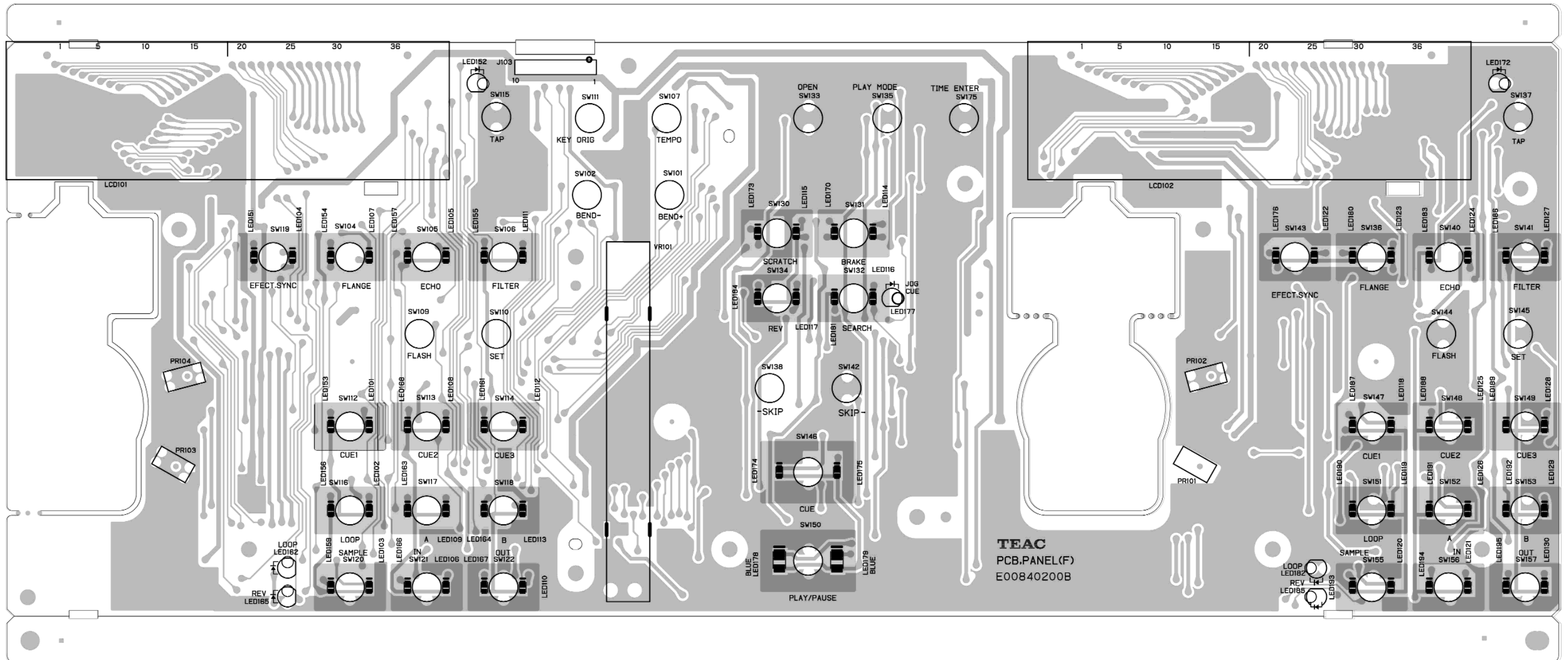

PCB PANEL.CD-X1700 SIDE B

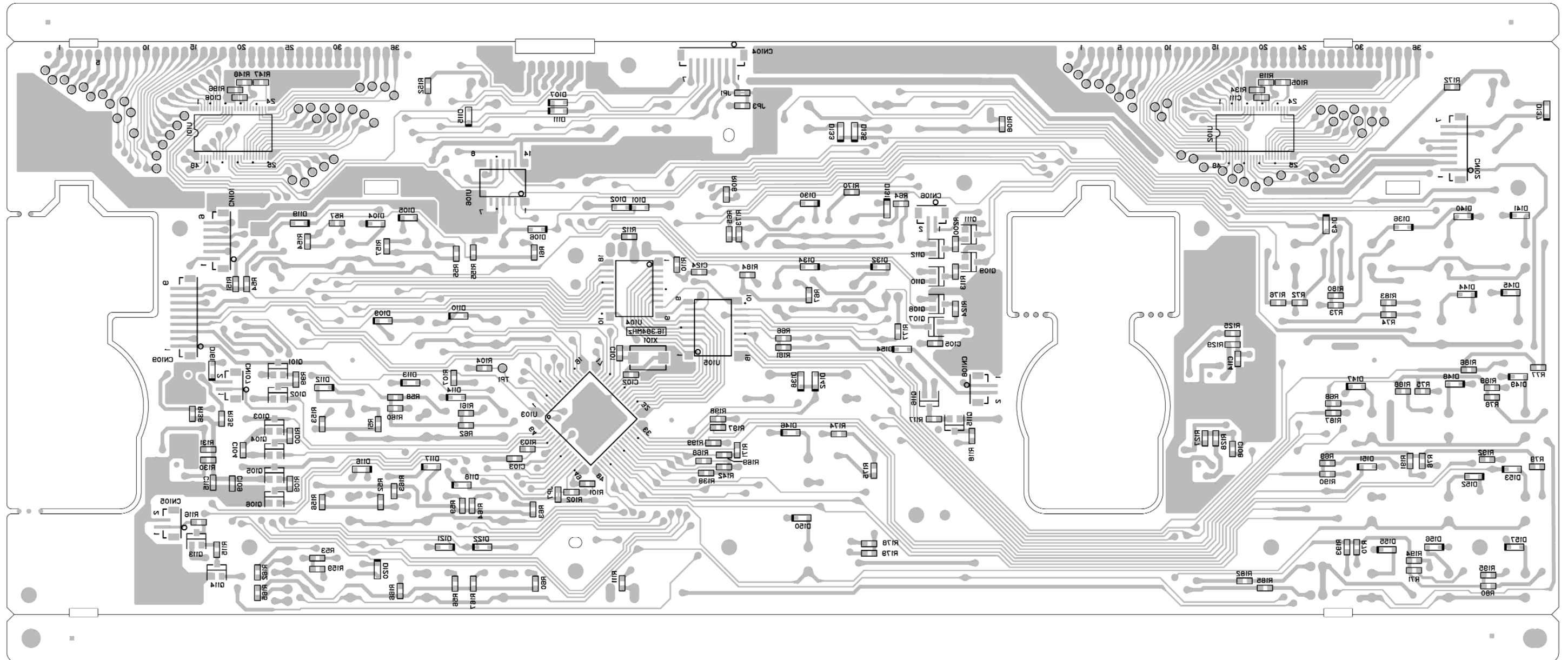

**GATHER PCB(G) ( PCB.REAR(G) PCB.L(G) PCB.R(G) PCB.SW L(G) PCB.SW R(G) )**

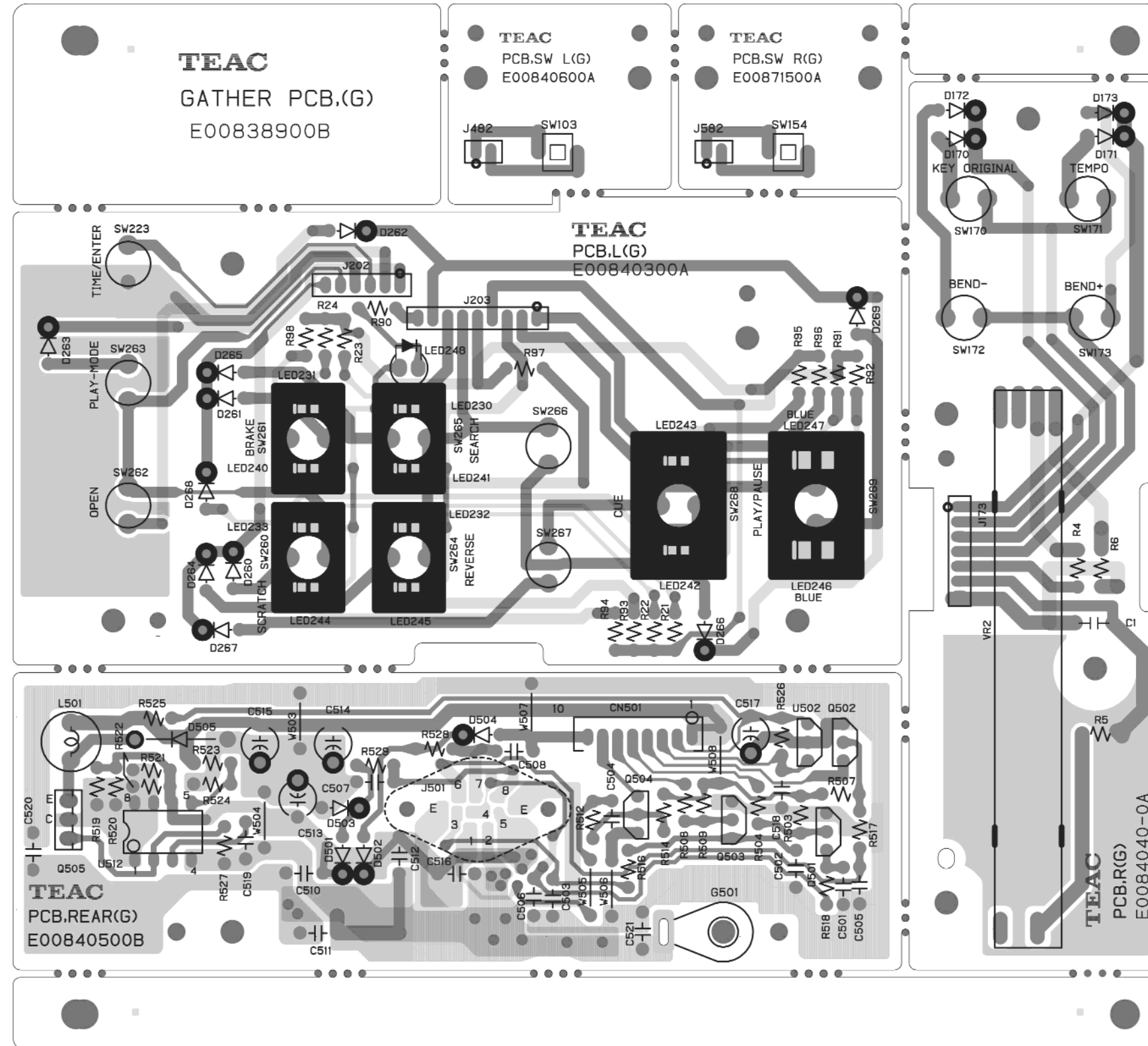

## MAIN PCB ASSY

REF.NO.	PARTS NO.	DESCRIPTION
	3E95735-00A	PCBA,MAIN CD-X1500
CN201	3E008400	CONNECTOR,FFC 6232 016 006
CN205	3E010380	CONNECT PLUG B 6B-PH-K-S
CN206	3E010370	CONNECT PLUG B 5B-PH-K-S
CN207	3E003830	CONNECTOR,PLUG B4B-PH RED
CN209	3E010400	CONNECT PLUG B 8B-PH-K-S
CN210	3E010360	CONNCT PLUG B 4B-PH-K-S
CNM3	3E030350	CONNECTOR,19R-JE
CNM4	3E030350	CONNECTOR,19R-JE
CNM9	3E030350	CONNECTOR,19R-JE
D201	3S009844	DI,ISS380
D204	3S000031	DI, 1N4003 TAPING W= 52MM
D205,D206	3S009844	DI,ISS380
D209	3S009844	DI,ISS380
D210	3S010254	ZD1,UDZS 3.9B
D211	3S009844	DI,ISS380
D212	3S009844	DI,ISS380
FB201	3E035850	BEAD CORE,ZBF116T-01A
FB202	3E035850	BEAD CORE,ZBF116T-01A
FB203FB20	3E035850	BEAD CORE,ZBF116T-01A
FB205,206	3E033140	GEAD CORE,ZBF503AR-00TA
FB207	3E033140	GEAD CORE,ZBF503AR-00TA
FB208,209	3E033140	GEAD CORE,ZBF503AR-00TA
FB210,211	3E033140	GEAD CORE,ZBF503AR-00TA
FB212	3E035850	BEAD CORE,ZBF116T-01A
G200	3E02152-00A	EARTH PLATE B GND-8
G201	3E02152-00A	EARTH PLATE B GND-8
J201	3E030280	JACK,YKC 21-3487
J202	3E030270	JACK,YKC 21-3486
J203	3E030310	CONNECTOR,TCS 7927-26-401
J204	3E030290	JACK,PHONE JY-3550*01-020
L202	3E011810	COIL,47 UH K
L203,L204	3E011810	COIL,47 UH K
L205,L206	3E008992	COIL,3.3UH EC24-3R3K TP
L207,L208	3E008992	COIL,3.3UH EC24-3R3K TP
L209	3E008992	COIL,3.3UH EC24-3R3K TP
Q201	3S008144	TR,2SA1036KQ
Q202	3S006984	DTR,DTA124EKAT-146
Q203,Q204	3S007804	TR,DTC144EKA T146
Q205	3S007804	TR,DTC144EKA T146
Q206	3S007944	TR,2SD2150R
Q207,Q208	3S010264	TR,DTC114EKA T146 TP
Q209,Q210	3S005114	TR,2SD1757K T146 TP
Q211	3S003004	TR,2SA1037AK T146 TP
Q212	3S010264	TR,DTC114EKA T146 TP
Q214	3S002432	TR,DTC143EK T146 TP
Q215,Q216	3S002432	TR,DTC143EK T146 TP
Q219	3S003004	TR,2SA1037AK T146 TP
Q220	3S034504	TR,DTA144EKA T146
Q221	3S034504	TR,DTA144EKA T146

## MAIN PCB ASSY

REF.NO.	PARTS NO.	DESCRIPTION
T201	3E01323-00A	PULS TRANS S-701-001
U201	3S006404	IC,CXD3068Q
U202	3S003304	IC,CXA2581N-T4
U203	3S009914	IC,BA5974EP
U204	3S009814	IC,BA6287F
U206	3S009894	IC,PCM 1742KE
U207	3S005354	IC,NJM4558M-TE3(8P)
U208,U209	3S002974	IC,BA033FP-E2(SMT,TAPING)
U210	3S001350	IC,74HCT04AF
U211	3S005234	IC,BD4730G-TR
U212	3S034044	IC,SN74LVC2G14DCKR

## GATHER(D) PCB ASSY

REF.NO.	PARTS NO.	DESCRIPTION
	3E95736-00A	PCBA,GAT(D) CD-X1500
		PCB,POWER
C401	△ 3C001352	CE, 16V 10000UF M TP
C403	△ 3C001082	CE, 25V 1000UF M TP
C408	△ 3C000342	CE, 25V 10 UF M TP
CN403	3E001170	CONNECT PLUG 5P B5B-EH-A
CN404CN40	3E010400	CONNECT PLUG B 8B-PH-K-S
D401	△ 3S009900	DI,D10XB20
D402,D403	△ 3S000031	DI, 1N4003 TAPING W= 52MM
D405	3S006101	ZDI,RD3.3ES AB2 T72 26MM
G16	3E02152-00A	EARTH PLATE B GND-8
J401	3E030300	CONNECTOR,TCS7927-28-401
J402	E008439-00A	HARNESS ASSY,J
J403	E008440-00A	HARNESS ASSY,K
U401	△ 3S004730	IC,BA17807T
U402	△ 3S008160	IC,BA05T
U403	△ 3S008170	IC,NJM7905FA(3P)
		PCB,TRANS
C411,C412	△ 3E004300	S.KILLER,CS12-F2GA472MYAS
CN406	3E001170	CONNECT PLUG 5P B5B-EH-A
CN407	3E025820	CONNECT,B2P3-VH 2P
F401,F402	△ 3E033020	FUSE,4A 250V T
F403	△ 3E033010	FUSE,250MA 250V T
P401	3E002170	PIN,TERMINAL LAPPING 2P
T402	△ 3E017230	FILTER,AC LINE LFH-601U
	3E006220	FUSE HOLDER 5.0 FUSE
		PCB,OPEN
J405	E008446-00A	HARNESS ASSY,Q
J406	E008447-00A	HARNESS ASSY,R
J410,J411	E008448-00A	HARNESS ASSY,S
R410,R411	3R000581	RD, 1/8W 270 OHM J 26MM
SW402SW40	3E018680	SW,TACT SKQNAE D010

**GATHER(D) PCB ASSY**

REF.NO.	PARTS NO.	DESCRIPTION
LED402	3S010210	PCB,LED A
	3M02154-00A	LED,SLA560BBT3F(BLU) SPACER,LH-5-6 D5
LED403	3S010210	PCB,LED B
	3M02154-00A	LED,SLA560BBT3F(BLU) SPACER,LH-5-6 D5
C413 SW401	△ 3E004300	PCB,SW
	△ 3E033112	S.KILLER,CS12-F2GA472MYAS
	E008444-00A	SW,SDKLA10300 HARNESS ASSY,O

**DSP PCB -L ASSY**

REF.NO.	PARTS NO.	DESCRIPTION
	3E95743-00A	PCBA,DSP-L CD-X1500
CN802	3E007950	CONNECTOR ,B 2B-ZR
CN803CN80	3E030340	CONNECTOR,19PS-JE
CN809	3E030340	CONNECTOR,19PS-JE
D801	3S005074	DIODE,RB161L-40 TE25
D803	3S005074	DIODE,RB161L-40 TE25
U801	S0052333	IC,SCF5249VF140
U802	3S009444	M12L64164A-7T
U803	S005341-00A	IC,ROM MAIN X1500 V0100
U811	3S033474	IC,BA18BCOFP
U812	3S033744	IC,SN74LVLC2GU04DCKR
U813	3S009884	IC,M24512-WMW
U814	3S006384	IC,SN74LVLCIG125DCKR
X801	3E021414	LIMAZA 33.8688MHZ

**DSP PCB -R ASSY**

REF.NO.	PARTS NO.	DESCRIPTION
	3E95743-10A	PCBA,DSP-R CD-X1500
CN802	3E007950	CONNECTOR ,B 2B-ZR
CN803CN80	3E030340	CONNECTOR,19PS-JE
CN809	3E030340	CONNECTOR,19PS-JE
D801	3S005074	DIODE,RB161L-40 TE25
D803	3S005074	DIODE,RB161L-40 TE25
U801	S0052333	IC,SCF5249VF140
U802	3S009444	M12L64164A-7T
U803	S005341-00A	IC,ROM MAIN X1500 V0100
U811	3S033474	IC,BA18BCOFP
U812	3S033744	IC,SN74LVLC2GU04DCKR
U814	3S006384	IC,SN74LVLCIG125DCKR
X801	3E021414	LIMAZA 33.8688MHZ

**WIRE SECT, DECK CD-X1500**

REF.NO.	PARTS NO.	DESCRIPTION
	E008436-00A	HARNESS ASSY,G
	E008437-00A	HARNESS ASSY,H
	E008438-00A	HARNESS ASSY,I
	E008441-00A	HARNESS ASSY,L
	E008442-00A	HARNESS ASSY,M
	E008443-00A	HARNESS ASSY,N

## PANEL PCB ASSY CD-X1500

REF.NO.	PARTS NO.	DESCRIPTION
	3E95746-00A	PCBA,GAT(A) CD-X1500
		PCB,PANEL CD-X1500
CN101	3E008080	CONNECTOR ,B 4B-ZR-SM3-TF
CN103	53363868-00	CONN PL 8P B8BZRSM3TF
CN105	53363863-00	CONNECTOR,B3B-ZR-SM3-TF
CN106	53363868-00	CONN PL 8P B8BZRSM3TF
CN107	53363862-00	CONNECTOR,B2B-ZR-SM3-TF
CN108	3E007950	CONNECTOR ,B 2B-ZR
D103,D104	3S009844	DI,ISS380
D105,D106	3S009844	DI,ISS380
D107,D108	3S009844	DI,ISS380
D109,D110	3S009844	DI,ISS380
D111,D112	3S009844	DI,ISS380
D113,D114	3S009844	DI,ISS380
D115,D116	3S009844	DI,ISS380
D118	3S009844	DI,ISS380
D123,D124	3S009844	DI,ISS380
D125	3S009844	DI,ISS380
D133,D134	3S009844	DI,ISS380
D135,D136	3S009844	DI,ISS380
D137,D138	3S009844	DI,ISS380
D139,D140	3S009844	DI,ISS380
D143,D144	3S009844	DI,ISS380
D145,D146	3S009844	DI,ISS380
D147,D148	3S009844	DI,ISS380
D152	3S009844	DI,ISS380
D155,D156	3S009844	DI,ISS380
D159,D160	3S009844	DI,ISS380
D165,D166	3S009844	DI,ISS380
J109	E008430-00B	HARNES ASSY,A
LCD1,LCD2	E008407-00A	LCD,TSB2130-DBTDPN-SP
LED101-10	3S033524	LED,SML-512MW(GRN)
LED110	3S033524	LED,SML-512MW(GRN)
LED112-11	3S033524	LED,SML-512MW(GRN)
LED115	3S033500	LED,SLR342MG(GRN)
LED116,11	3S033514	LED,SML011BBT(BLUE)
LED118-13	3S033524	LED,SML-512MW(GRN)
LED136-13	3S033524	LED,SML-512MW(GRN)
LED140,14	3S033514	LED,SML011BBT(BLUE)
LED142-14	3S033524	LED,SML-512MW(GRN)
LED148	3S033524	LED,SML-512MW(GRN)
LED153	3S033524	LED,SML-512MW(GRN)
LED157	3S033524	LED,SML-512MW(GRN)
PR101,102	3S009820	PHOTO INTRPT,RPI-441C1
Q101	3S008144	TR,2SA1036KQ
Q102	3S002432	TR,DTC143EK T146 TP
Q103	3S008144	TR,2SA1036KQ
Q104	3S002432	TR,DTC143EK T146 TP
Q105	3S008144	TR,2SA1036KQ
Q106	3S002432	TR,DTC143EK T146 TP
Q107	3S008144	TR,2SA1036KQ

## PANEL PCB ASSY CD-X1500

REF.NO.	PARTS NO.	DESCRIPTION
Q108	3S002432	TR,DTC143EK T146 TP
Q109	3S008144	TR,2SA1036KQ
Q110	3S002432	TR,DTC143EK T146 TP
Q111	3S008144	TR,2SA1036KQ
Q112	3S002432	TR,DTC143EK T146 TP
Q113	3S003004	TR,2SA1037AK T146 TP
Q114	3S002432	TR,DTC143EK T146 TP
Q115	3S003004	TR,2SA1037AK T146 TP
Q116	3S002432	TR,DTC143EK T146 TP
SW102SW10	3E018680	SW,TACT SKQNAE D010
SW104SW10	3E018680	SW,TACT SKQNAE D010
SW106SW10	3E018680	SW,TACT SKQNAE D010
SW108SW10	3E018680	SW,TACT SKQNAE D010
SW110SW11	3E018680	SW,TACT SKQNAE D010
SW112SW11	3E018680	SW,TACT SKQNAE D010
SW114SW11	3E018680	SW,TACT SKQNAE D010
SW116SW11	3E018680	SW,TACT SKQNAE D010
SW123SW12	3E018680	SW,TACT SKQNAE D010
SW125	3E018680	SW,TACT SKQNAE D010
SW133SW13	3E018680	SW,TACT SKQNAE D010
SW135SW13	3E018680	SW,TACT SKQNAE D010
SW137SW13	3E018680	SW,TACT SKQNAE D010
SW139SW14	3E018680	SW,TACT SKQNAE D010
SW143SW14	3E018680	SW,TACT SKQNAE D010
SW145SW14	3E018680	SW,TACT SKQNAE D010
SW147SW14	3E018680	SW,TACT SKQNAE D010
SW152	3E018680	SW,TACT SKQNAE D010
SW155SW15	3E018680	SW,TACT SKQNAE D010
SW159SW16	3E018680	SW,TACT SKQNAE D010
SW165SW16	3E018680	SW,TACT SKQNAE D010
U101,U102	3S009654	IC,HT1621B-48
U103	S005231-00A	IC,M38034M4-475FP
U104,U105	3S009664	IC,TD62084AF
U106	3S008344	IC,HD74HC14FP-TR(14P)
VR101	R012884-00A	VAR RES,ES6011Y34 10KB
X101	3E034120	RESONATOR,LIM55A-T16.384M
	M018406-00A	SHEET,MIRROR CD-X1500
	3M01259-00A	HOLDER,LED H=13
	M016618-00A	HOLDER,LCD
	M016619-00A	LENS,
	M017588-00A	TAPE,REFLECT
	M016620-00A	SHEET,DIFFUSION
	M016621-00A	SHEET,REFLECT

**GATHER(B) PCB ASSY**

REF.NO.	PARTS NO.	DESCRIPTION
	3E95748-00A	PCBA,GAT(B) CD-X1500
		PCB,REAR CD-X1500
CN501	3E010400	CONNECT PLUG B 8B-PH-K-S
D505	3S008000	DI,21DQ04
G501	3E02152-00A	EARTH PLATE B GND-8
J501	3E033100	CONNECTOR,TCS7689
L501	3E030320	COIL,RCH-895 220UH
Q501,Q502	3S002450	TR,DTC114ESTP
Q503,Q504	3S002450	TR,DTC114ESTP
Q505	3S009832	TR,2SD2264(R)
U502	3S009804	IC,PST600D
U512	3S033570	IC,MC34063AP1
		PCB,L CD-X1500
D117	3S000241	DI, 1SS133 T-77
D120	3S000241	DI, 1SS133 T-77
D128	3S000241	DI, 1SS133 T-77
J102	E008432-00A	HARNESS ASSY,C
J110	E008431-00A	HARNESS ASSY,B
LED109,11	3S033524	LED,SML-512MW(GRN)
PR3,PR4	3S009820	PHOTO INTRPT,RPI-441C1
R95,R96	3R005964	RM,1/10W 39 OHM J 0603
SW101	3E018680	SW,TACT SKQNAE D010
SW120	3E018680	SW,TACT SKQNAE D010
SW127,128	3E018680	SW,TACT SKQNAE D010
		PCB,R CD-X1500
D141,D142	3S000241	DI, 1SS133 T-77
D149	3S000241	DI, 1SS133 T-77
D157	3S000241	DI, 1SS133 T-77
J112	E008434-00A	HARNESS ASSY,E
J113	E008433-00A	HARNESS ASSY,D
LED135	3S033524	LED,SML-512MW(GRN)
LED139	3S033500	LED,SLR342MG(GRN)
LED147	3S033524	LED,SML-512MW(GRN)
R177,R199	3R005964	RM,1/10W 39 OHM J 0603
SW141,142	3E018680	SW,TACT SKQNAE D010
SW149	3E018680	SW,TACT SKQNAE D010
SW157	3E018680	SW,TACT SKQNAE D010
VR2	R012884-00A	VAR RES,ES6011Y34 10KB
	3M01259-00A	HOLDER,LED H=13

**GATHER(E) PCB ASSY**

REF.NO.	PARTS NO.	DESCRIPTION
	3E95752-00A	PCBA,GAT(E) CD-X1500
		PCB,LCD
J48	E008435-00A	HARNESS ASSY,F
LED149,16	3S009874	LED,NSC W 100S(WHITE)

**DSP PCB -L ASSY**

REF.NO.	PARTS NO.	DESCRIPTION
	3E95743-20A	PCBA,DSP-L CD-X1700
CN802	3E007950	CONNECTOR ,B 2B-ZR
CN803CN80	3E030340	CONNECTOR,19PS-JE
CN809	3E030340	CONNECTOR,19PS-JE
D801	3S005074	DIODE,RB161L-40 TE25
D803	3S005074	DIODE,RB161L-40 TE25
D820	3C022994	CC,25V F 0.10UF Z 0402
U801	S0052333	IC,SCF5249VF140
U802	3S009444	M12L64164A-7T
U803	S005348-00A	IC,ROM MAIN X1700 V0100
U809	S0052333	IC,SCF5249VF140
U810	3S033483	IC,M12L16161A-7T
U811	3S033474	IC,BA18BCOFP
U812	3S033744	IC,SN74LVC2GU04DCKR
U813	3S009884	IC,M24512-WMW
U814	3S006384	IC,SN74LVCIG125DCKR
U815	S005349-00A	IC,ROM DSP X1700 V0100
X801	3E021414	LIMAZA 33.8688MHZ

**DSP PCB -R ASSY**

REF.NO.	PARTS NO.	DESCRIPTION
	3E95743-30A	PCBA,DSP-R,CD-X1700
CN802	3E007950	CONNECTOR ,B 2B-ZR
CN803CN80	3E030340	CONNECTOR,19PS-JE
CN809	3E030340	CONNECTOR,19PS-JE
D801	3S005074	DIODE,RB161L-40 TE25
D803	3S005074	DIODE,RB161L-40 TE25
D820	3C022994	CC,25V F 0.10UF Z 0402
U801	S0052333	IC,SCF5249VF140
U802	3S009444	M12L64164A-7T
U803	S005348-00A	IC,ROM MAIN X1700 V0100
U809	S0052333	IC,SCF5249VF140
U810	3S033483	IC,M12L16161A-7T
U811	3S033474	IC,BA18BCOFP
U812	3S033744	IC,SN74LVC2GU04DCKR
U814	3S006384	IC,SN74LVCIG125DCKR
U815	S005349-00A	IC,ROM DSP X1700 V0100
X801	3E021414	LIMAZA 33.8688MHZ
	M016638-00A	BUTTON,OPEN P

**PANEL(F) PCB ASSY CD-X1700**

REF.NO.	PARTS NO.	DESCRIPTION
	3E95827-00A	PCBA PANEL,CD-X1700
CN101	53363866-00	CONN PL 6P B6BZRSM3TF
CN102	3E008110	CONNECTOR ,B 7B-ZR-SM3-TF
CN105	53363862-00	CONNECTOR,B2B-ZR-SM3-TF
CN106	53363862-00	CONNECTOR,B2B-ZR-SM3-TF
CN109	3E008130	CONNECTOR ,B 9B-ZR-SM3-TF
D101,D102	3S009844	DI,ISS380
D104	3S009844	DI,ISS380
D105,D106	3S009844	DI,ISS380
D107	3S009844	DI,ISS380
D109,D110	3S009844	DI,ISS380
D111,D112	3S009844	DI,ISS380
D113,D114	3S009844	DI,ISS380
D115,D116	3S009844	DI,ISS380
D117,D118	3S009844	DI,ISS380
D119,D120	3S009844	DI,ISS380
D121,D122	3S009844	DI,ISS380
D130	3S009844	DI,ISS380
D131,D132	3S009844	DI,ISS380
D133,D134	3S009844	DI,ISS380
D135,D136	3S009844	DI,ISS380
D137,D138	3S009844	DI,ISS380
D140,D141	3S009844	DI,ISS380
D142	3S009844	DI,ISS380
D143,D144	3S009844	DI,ISS380
D145,D146	3S009844	DI,ISS380
D147,D148	3S009844	DI,ISS380
D149,D150	3S009844	DI,ISS380
D151,D152	3S009844	DI,ISS380
D153	3S009844	DI,ISS380
D155,D156	3S009844	DI,ISS380
D157	3S009844	DI,ISS380
J103	E008625-00A	HARNESS ASSY,A7
LCD1,LCD2	E008407-00A	LCD,TSB2130-DBTDPN-SP
LED101-11	3S033524	LED,SML-512MW(GRN)
LED111-12	3S033524	LED,SML-512MW(GRN)
LED121-13	3S033524	LED,SML-512MW(GRN)
LED151	3S033524	LED,SML-512MW(GRN)
LED152	3S033500	LED,SLR342MG(GRN)
LED153-15	3S033524	LED,SML-512MW(GRN)
LED159,16	3S033524	LED,SML-512MW(GRN)
LED162	3S033500	LED,SLR342MG(GRN)
LED163,16	3S033524	LED,SML-512MW(GRN)
LED165	3S033500	LED,SLR342MG(GRN)
LED166-16	3S033524	LED,SML-512MW(GRN)
LED170	3S033524	LED,SML-512MW(GRN)
LED172	3S033500	LED,SLR342MG(GRN)
LED173	3S033524	LED,SML-512MW(GRN)
LED174-17	3S033524	LED,SML-512MW(GRN)
LED178,17	3S033514	LED,SML011BBT(BLUE)
LED180,18	3S033524	LED,SML-512MW(GRN)

**PANEL(F) PCB ASSY CD-X1700**

REF.NO.	PARTS NO.	DESCRIPTION
LED182	3S033500	LED,SLR342MG(GRN)
LED183,18	3S033524	LED,SML-512MW(GRN)
LED185	3S033500	LED,SLR342MG(GRN)
LED186-19	3S033524	LED,SML-512MW(GRN)
PR101,102	3S009820	PHOTO INTRPT,RPI-441C1
PR103,104	3S009820	PHOTO INTRPT,RPI-441C1
Q101	3S008144	TR,2SA1036KQ
Q102	3S002432	TR,DTC143EK T146 TP
Q103	3S008144	TR,2SA1036KQ
Q104	3S002432	TR,DTC143EK T146 TP
Q105	3S008144	TR,2SA1036KQ
Q106	3S002432	TR,DTC143EK T146 TP
Q107	3S008144	TR,2SA1036KQ
Q108	3S002432	TR,DTC143EK T146 TP
Q109	3S008144	TR,2SA1036KQ
Q110	3S002432	TR,DTC143EK T146 TP
Q111	3S008144	TR,2SA1036KQ
Q112	3S002432	TR,DTC143EK T146 TP
Q113	3S003004	TR,2SA1037AK T146 TP
Q114	3S002432	TR,DTC143EK T146 TP
Q115	3S003004	TR,2SA1037AK T146 TP
Q116	3S002432	TR,DTC143EK T146 TP
SW101,102	3E018680	SW,TACT SKQNAE D010
SW104,105	3E018680	SW,TACT SKQNAE D010
SW106,107	3E018680	SW,TACT SKQNAE D010
SW109,110	3E018680	SW,TACT SKQNAE D010
SW111,112	3E018680	SW,TACT SKQNAE D010
SW113,114	3E018680	SW,TACT SKQNAE D010
SW115,116	3E018680	SW,TACT SKQNAE D010
SW117,118	3E018680	SW,TACT SKQNAE D010
SW119,120	3E018680	SW,TACT SKQNAE D010
SW121,122	3E018680	SW,TACT SKQNAE D010
SW130,131	3E018680	SW,TACT SKQNAE D010
SW132,133	3E018680	SW,TACT SKQNAE D010
SW134,135	3E018680	SW,TACT SKQNAE D010
SW136,137	3E018680	SW,TACT SKQNAE D010
SW138	3E018680	SW,TACT SKQNAE D010
SW140,141	3E018680	SW,TACT SKQNAE D010
SW142,143	3E018680	SW,TACT SKQNAE D010
SW144,145	3E018680	SW,TACT SKQNAE D010
SW146,147	3E018680	SW,TACT SKQNAE D010
SW148,149	3E018680	SW,TACT SKQNAE D010
SW150,151	3E018680	SW,TACT SKQNAE D010
SW152,153	3E018680	SW,TACT SKQNAE D010
SW155,156	3E018680	SW,TACT SKQNAE D010
SW157	3E018680	SW,TACT SKQNAE D010
SW175	3E018680	SW,TACT SKQNAE D010
U101,U102	3S009654	IC,HT1621B-48
U103	S005231-00A	IC,M38034M4-475FP

**PANEL(F) PCB ASSY CD-X1700**

REF.NO.	PARTS NO.	DESCRIPTION
U104,U105	3S009664	IC,TD62084AF
U106	3S008344	IC,HD74HC14FP-TR(14P)
VR101	R012884-00A	VAR RES,ES6011Y34 10KB
X101	3E034120	RESONATOR,LIM55A-T16.384M
	3M01259-00A	HOLDER,LED H=13
	M016618-00A	HOLDER,LCD
	M016619-00A	LENS,
	M017588-00A	TAPE,REFLECT
	M016620-00A	SHEET,DIFFUSION
	M018406-00A	SHEET,MIRROR CD-X1500
	M016621-00A	SHEET,REFLECT

**GATHER (G) PCB ASSY CD-X1700**

REF.NO.	PARTS NO.	DESCRIPTION
	3E95828-00A	PCBA,GAT(G),CD-X1700
		PCB,R(G) CD-X1700
		PCB,SW L(G)
		PCB,SW R(G)
		PCB,L(G) CD-X1700
LED230-23	3S033524	LED,SML-512MW(GRN)
LED240-24	3S033524	LED,SML-512MW(GRN)
LED246,24	3S033514	LED,SML011BBT(BLUE)
		PCB,REAR(G) CD-X1700
CN501	3E010400	CONNECT PLUG B 8B-PH-K-S
D170,D171	3S000241	DI, 1SS133 T-77
D172,D173	3S000241	DI, 1SS133 T-77
D260,D261	3S000241	DI, 1SS133 T-77
D262	3S000241	DI, 1SS133 T-77
D263,D264	3S000241	DI, 1SS133 T-77
D265,D266	3S000241	DI, 1SS133 T-77
D267,D268	3S000241	DI, 1SS133 T-77
D269	3S000241	DI, 1SS133 T-77
D505	3S008000	DI,21DQ04
G501	3E02152-00A	EARTH PLATE B GND-8
J173	E008628-00A	HARNESS ASSY,D7
J202	E008627-00A	HARNESS ASSY,C7
J203	E008626-00A	HARNESS ASSY,B7
J501	3E033100	CONNECTOR,TCS7689
L501	3E030320	COIL,RCH-895 220UH
Q501,Q502	3S002450	TR,DTC114ESTP
Q503,Q504	3S002450	TR,DTC114ESTP
Q505	3S009832	TR,2SD2264(R)
SW170SW17	3E018680	SW,TACT SKQNAE D010
SW172SW17	3E018680	SW,TACT SKQNAE D010
SW223	3E018680	SW,TACT SKQNAE D010
SW260SW26	3E018680	SW,TACT SKQNAE D010
SW262SW26	3E018680	SW,TACT SKQNAE D010
SW264SW26	3E018680	SW,TACT SKQNAE D010

**PANEL(F) PCB ASSY CD-X1700**

REF.NO.	PARTS NO.	DESCRIPTION
SW266SW26	3E018680	SW,TACT SKQNAE D010
SW268SW26	3E018680	SW,TACT SKQNAE D010
U502	3S009804	IC,PST600D
U512	3S033570	IC,MC34063AP1
VR2	R012884-00A	VAR RES,ES6011Y34 10KB

**GATHER (E) PCB ASSY**

REF.NO.	PARTS NO.	DESCRIPTION
	3E95752-10A	PCBA,GAT(E),CD-X1700
		PCB,LCD
J48	E008631-00B	HARNESS ASSY,P7
LED149,16	3S009874	LED,NSC W 100S(WHITE)
	D007852-00A	OWNERS MNL,JPN CD-X1700
	D007853-00A	OWNERS MNL,E CD-X1700

## 6. INCLUDED ACCESSORIES

付属品

### INCLUDED ACCESSORIES (CD-X1500)

REF.NO.	PARTS NO.	DESCRIPTION	REMARKS
	D007831-00A	OWNERS MNL,JPN X1500	
	D007832-00A	OWNERS MNL,E X1500	
	D007833-00A	OWNERS MNL,E/S X1500	
	D007834-00A	OWNERS MNL,EFGIS X1500	
	E008410-00A	CABLE ASSY 8P L2	
	E008412-00A	CABLE,ASSY,FADER L2	
	3M00283-00A	ASSY,RACK MOUNT SCREW KIT	
	3B00058-12A	SCREW,BPA M5X12 (NI)	

**INCLUDED ACCESSORIES (CD-X1700)**

REF.NO.	PARTS NO.	DESCRIPTION	REMARKS
	D007852-00A	OWNERS MNL,JPN CD-X1700	
	D007853-00A	OWNERS MNL,E CD-X1700	
	D007854-00A	OWNERS MNL,E/S CD-X1700	
	D007855-00A	OWNERS MNL,EFGIS X1700	
	D008116-00A	KEY CONTROL PAGE	
	E008410-00A	CABLE ASSY 8P L2	
	E008412-00A	CABLE,ASSY,FADER L2	
	3M00283-00A	ASSY,RACK MOUNT SCREW KIT	
	3B00058-12A	SCREW,BPA M5X12 (NI)	

**CONTENTS 目次**

MAIN .....	2
DSP .....	3
PANEL (CD-X1500) .....	4
PANEL (CD-X1700) .....	5

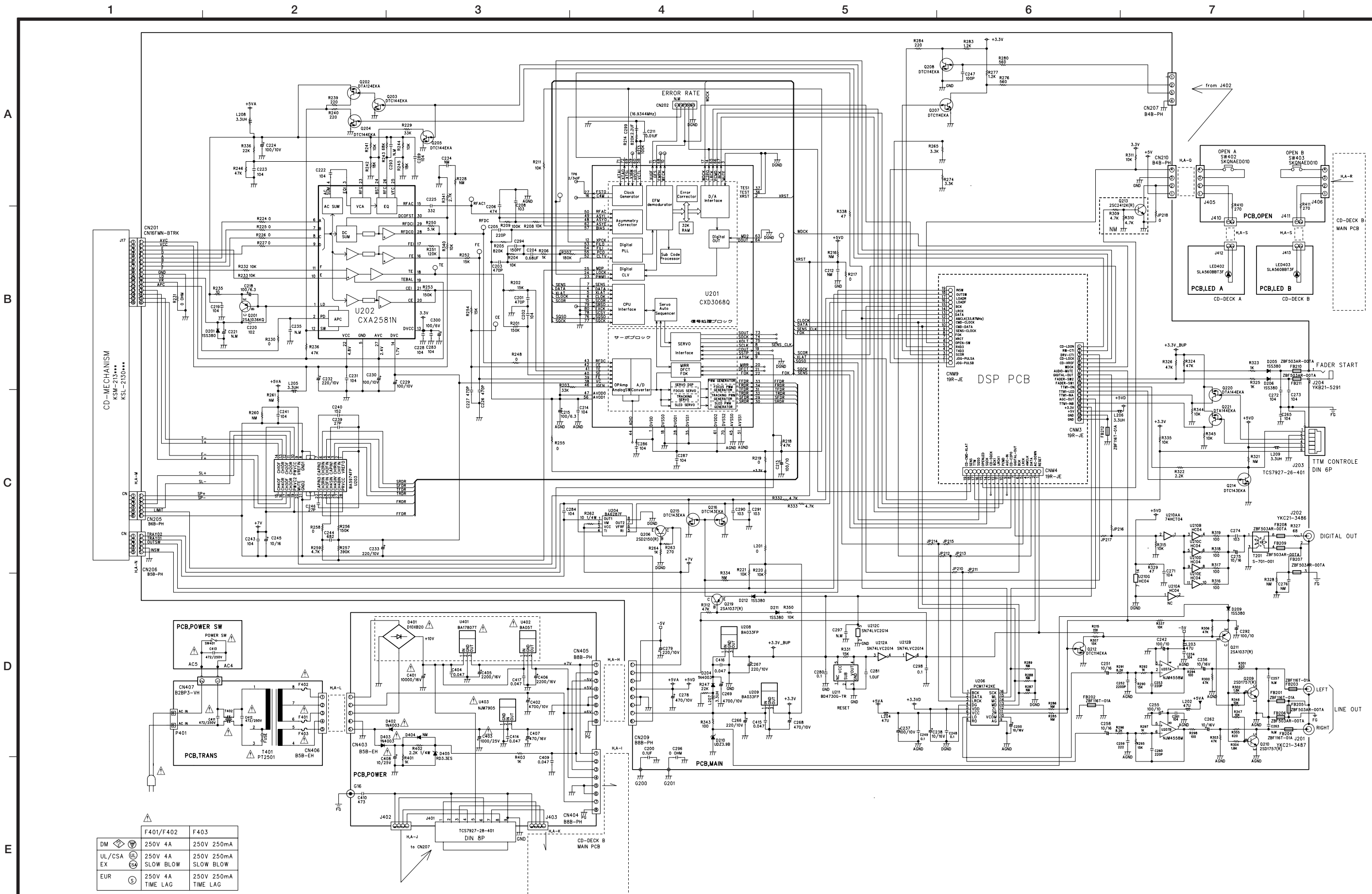

	F401/F402	F403
DM	250V 4A	250V 250mA
UL/CSA	250V 4A	250V 250mA
EX	SLOW BLOW	SLOW BLOW
EUR	250V 4A	250V 250mA
	TIME LAG	TIME LAG

Dual CD Player **CD-X1500 & CD-X1700**

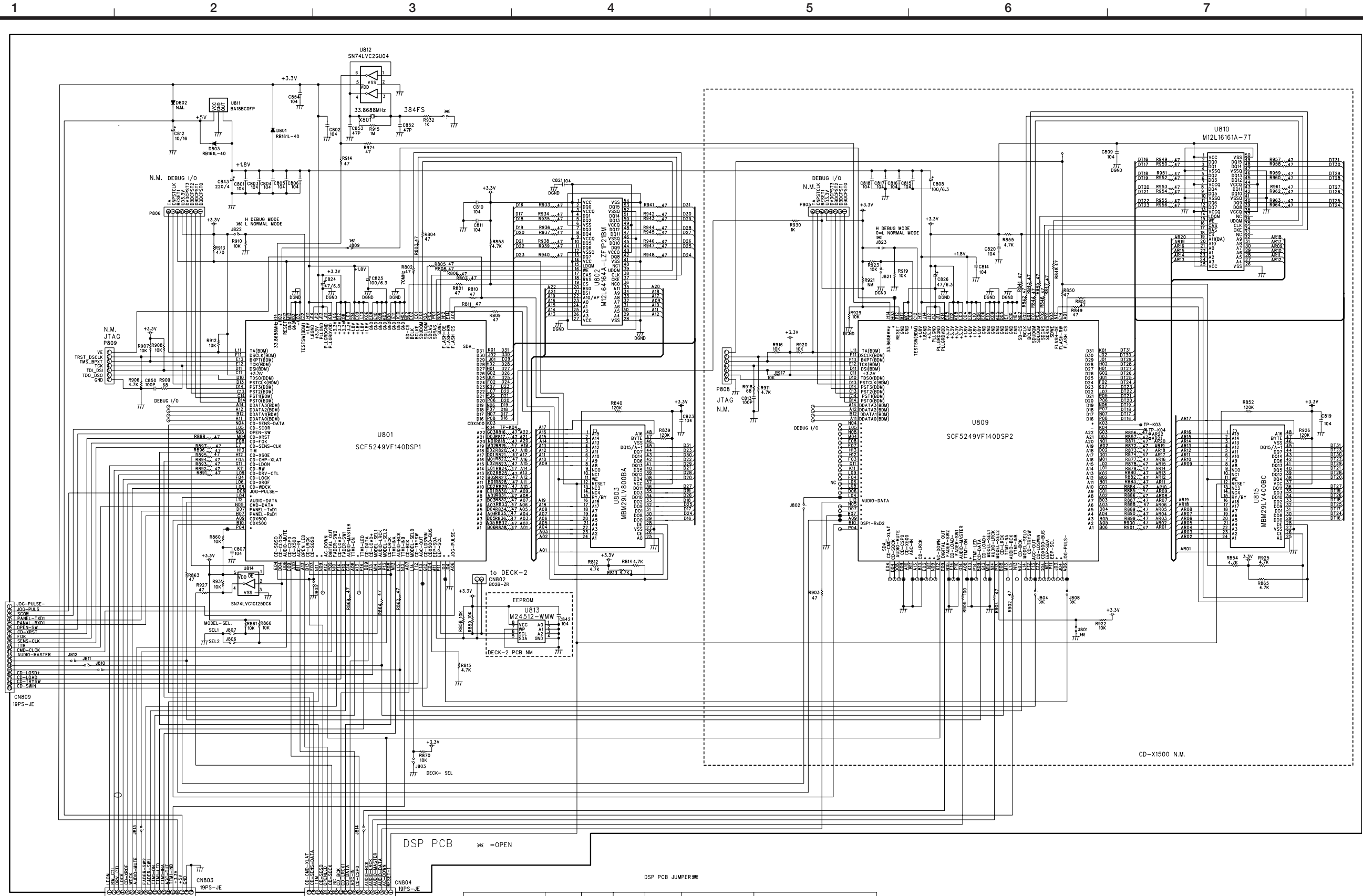

DSP PCB JUMPER表

	J801	J803	J806	J807	J810 J811 J812 J813	J814 J821 J802 J804 J808
PCBA, DSP-L CD-X1500		SHORT	SHORT	SHORT	SHORT	
PCBA, DSP-R CD-X1500			SHORT	SHORT	SHORT	
PCBA, DSP-L CD-X1700	SHORT	SHORT	SHORT			SHORT
PCBA, DSP-R CD-X1700			SHORT			SHORT
PCBA, DSP CD-900S	SHORT	SHORT				SHORT

# Dual CD Player CD-X1500 & CD-X1700

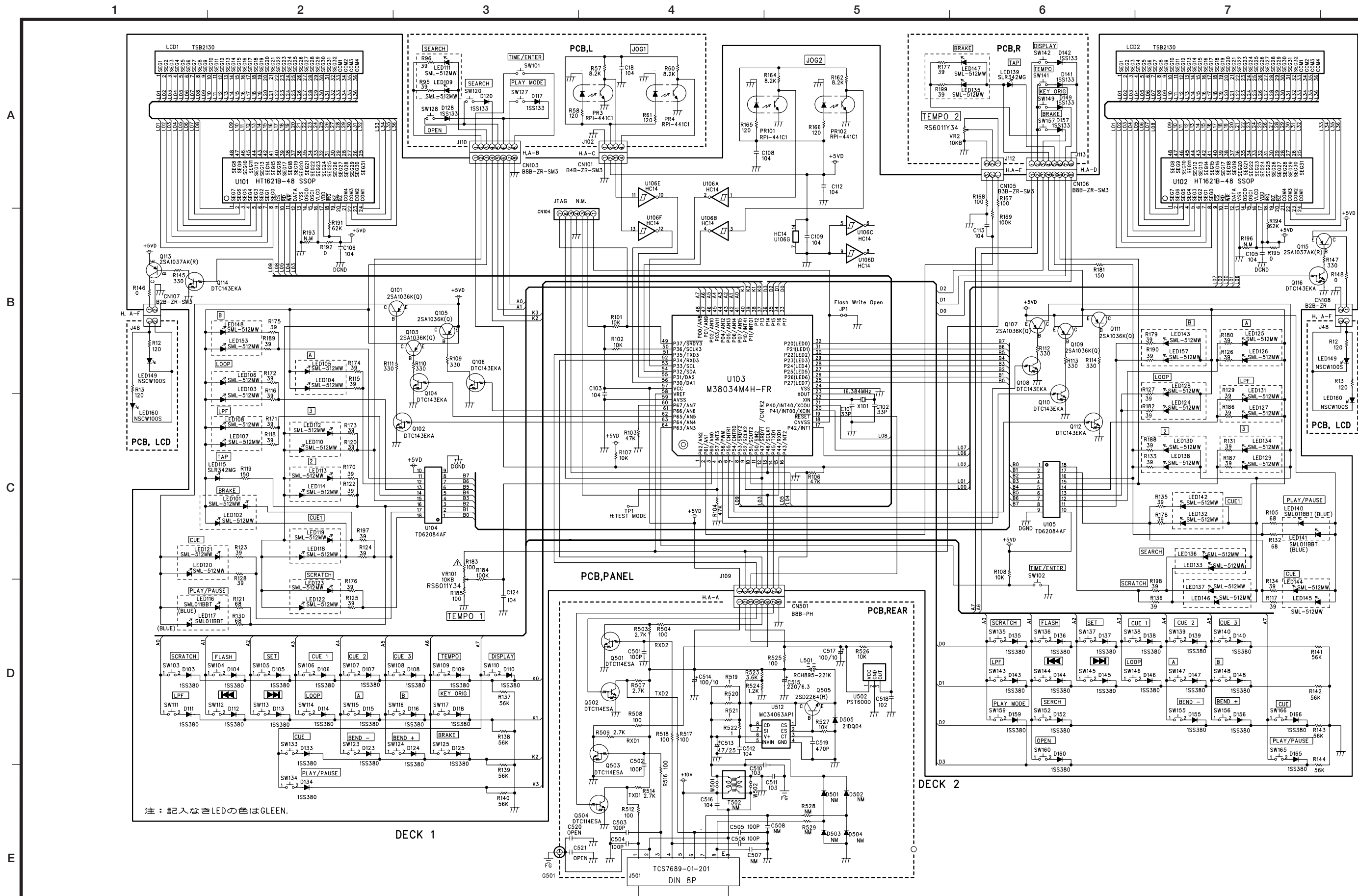

注：記入なきLEDの色はGLEEN.

DECK 1

DECK 2

1 2 3 4 5 6 7

A  
B  
C  
D  
E

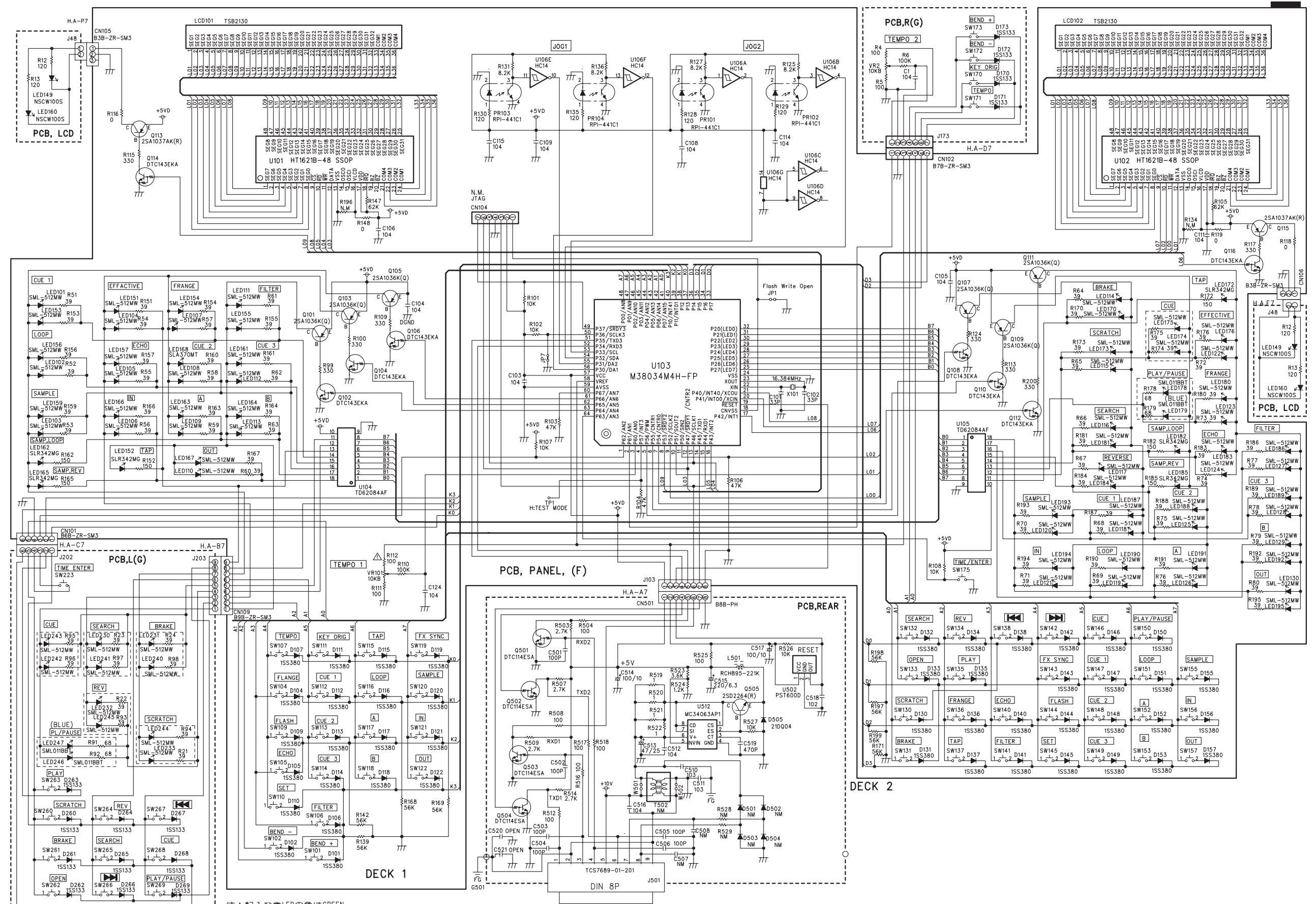

注：記入なきLEDの色はGREEN.

# TEAC TECHNICAL INFORMATION

TASCAM CD-X1500/CD-X1700, Service Hint for Buzz Noise  
 No. 0513  
 DATE 27th October 2005

To fulfill following work will suppress the buzz noise toned with PAUSE LED blinking.  
 This may become audible through GND loop built upon mounting the unit in a rack with Amplifier.

## 1. Main PCB Assy on the MAIN UNIT

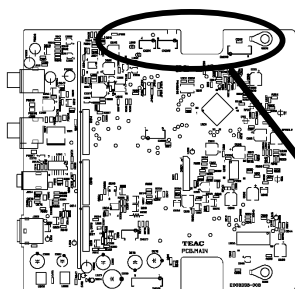

- Add a jumper wire between C242 (+) and G200 (GND).
- One unit has two pcs of Main PCB Assy so that the same work should be applied to both PCB Assy.

Jumper wire L=100 mm

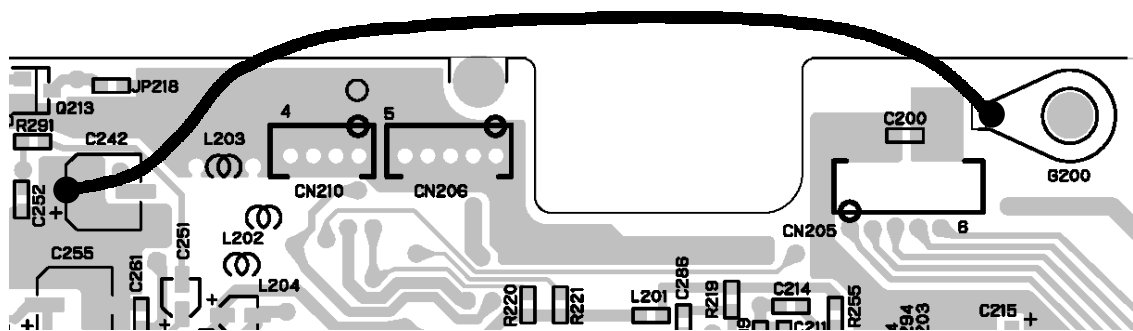

## 2. Rear PCB Assy on the CONTROL UNIT

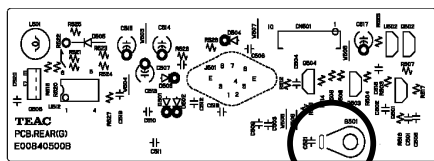

Parts side

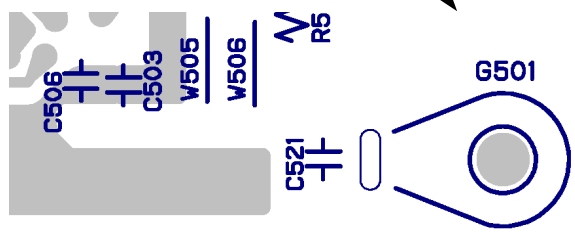

- Mount 0.1  $\mu$ F (ceramic capacitor ) onto C521 (vacant).

Soldering side

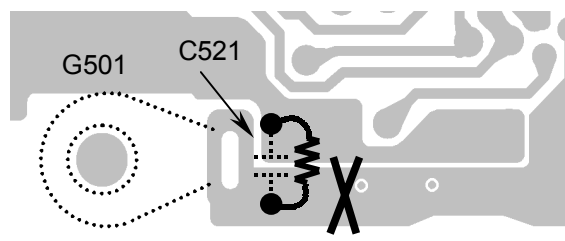

- Cut the foil pattern as shown above.
- Mount 10  $\Omega$  parallel to C521.



## 24-Bit, 192kHz Sampling Enhanced Multilevel, Delta-Sigma, Audio DIGITAL-TO-ANALOG CONVERTER

### FEATURES

- 24-BIT RESOLUTION
- ANALOG PERFORMANCE ( $V_{CC} = +5V$ ):  
Dynamic Range: 106dB typ (PCM1742KE)  
100dB typ (PCM1742E)  
SNR: 106dB typ (PCM1742KE)  
100dB typ (PCM1742E)  
THD+N: 0.002% typ (PCM1742KE)  
0.003% typ (PCM1742E)  
Full-Scale Output: 3.1Vp-p typ
- 4x/8x OVERSAMPLING DIGITAL FILTER:  
Stopband Attenuation: -55dB  
Passband Ripple:  $\pm 0.03$ dB
- SAMPLING FREQUENCY: 5kHz to 200kHz
- SYSTEM CLOCK: 128, 192, 256, 384, 512, 768f<sub>s</sub> with Auto Detect
- ACCEPTS 16-, 18-, 20-, AND 24-BIT AUDIO DATA
- DATA FORMATS: Standard, I<sup>2</sup>S, and Left-Justified
- USER-PROGRAMMABLE MODE CONTROLS:  
Digital Attenuation: 0dB to -63dB, 0.5dB/Step  
Digital De-Emphasis  
Digital Filter Roll-Off: Sharp or Slow  
Soft Mute  
Zero Flags for Each Output
- DUAL-SUPPLY OPERATION:  
+5V Analog, +3.3V Digital

- 5V TOLERANT DIGITAL INPUTS
- SMALL SSOP-16 PACKAGE
- SAME PACKAGE SIZE AS SOP-8

### APPLICATIONS

- AV RECEIVERS
- DVD MOVIE PLAYERS
- DVD ADD-ON CARDS FOR HIGH-END PCs
- DVD AUDIO PLAYERS
- HDTV RECEIVERS
- CAR AUDIO SYSTEMS
- OTHER APPLICATIONS REQUIRING 24-BIT AUDIO

### DESCRIPTION

The PCM1742 is a CMOS, monolithic, integrated circuit which includes stereo Digital-to-Analog Converters (DACs) and support circuitry in a small SSOP-16 package. The data converters utilize Texas Instrument's enhanced multilevel delta-sigma architecture that employs fourth-order noise shaping and 8-level amplitude quantization to achieve excellent dynamic performance and improved tolerance to clock jitter. The PCM1742 accepts industry standard audio data formats with 16- to 24-bit data, providing easy interfacing to audio DSP and decoder chips. Sampling rates up to 200kHz are supported. A full set of user-programmable functions are accessible through a 3-wire serial control port that supports register write functions.



# SPECIFICATIONS (Cont.)

All specifications at  $T_A = +25^\circ\text{C}$ ,  $V_{CC} = 5.0\text{V}$ ,  $V_{DD} = 3.3\text{V}$ , system clock =  $384f_S$  ( $f_S = 44.1\text{kHz}$ ), and 24-bit data, unless otherwise noted.

PARAMETER	CONDITIONS	PCM1742E PCM1742KE			UNITS
		MIN	TYP	MAX	
<b>DIGITAL FILTER PERFORMANCE (Cont.)</b> <b>Filter Characteristics 2, Slow Roll-Off</b>					
Passband	$\pm 0.5\text{dB}$			$0.198f_S$	
Passband	$-3\text{dB}$			$0.390f_S$	
Stopband		$0.884f_S$			
Passband Ripple				$\pm 0.5$	dB
Stopband Attenuation	Stopband = $0.884f_S$	$-40$			dB
Delay Time			$20/f_S$		sec
De-Emphasis Error			$\pm 0.1$		dB
<b>ANALOG FILTER PERFORMANCE</b>					
Frequency Response	$f = 20\text{kHz}$		$-0.03$		dB
	$f = 44\text{kHz}$		$-0.20$		dB
<b>POWER SUPPLY REQUIREMENTS<sup>(4)</sup></b>					
Voltage Range, $V_{DD}$		$+3.0$	$+3.3$	$+3.6$	VDC
$V_{CC}$		$+4.5$	$+5.0$	$+5.5$	VDC
Supply Current, $I_{DD}$	$f_S = 44.1\text{kHz}$		$6.0$	$10$	mA
	$f_S = 96\text{kHz}$		$13$		mA
	$f_S = 192\text{kHz}$		$16$		mA
$I_{CC}$	$f_S = 44.1\text{kHz}$		$8.5$	$13$	mA
	$f_S = 96\text{kHz}$		$9.0$		mA
	$f_S = 192\text{kHz}$		$9.0$		mA
Power Dissipation	$f_S = 44.1\text{kHz}$		$62$	$98$	mW
	$f_S = 96\text{kHz}$		$88$		mW
	$f_S = 192\text{kHz}$		$98$		mW
<b>TEMPERATURE RANGE</b>					
Operation Temperature		$-25$		$+85$	$^\circ\text{C}$
Thermal Resistance $\theta_{JA}$	SSOP-16		$115$		$^\circ\text{C/W}$

NOTES: (1) Pins 1, 2, 3, 16 (SCK, BCK, LRCK, DATA). (2) Pins 13-15 (MD, MC, ML). (3) Pins 11, 12 (ZEROR, ZEROL). (4) Analog performance specifications are tested with a Shibasoku #725 THD Meter with 400Hz HPF on, 30kHz LPF on, and an average mode with 20kHz bandwidth limiting. The load connected to the analog output is 5k $\Omega$  or larger, via capacitive coupling. (5) Conditions in 192kHz operation are: system clock =  $128f_S$  and oversampling rate =  $64f_S$  of Register 18.

## ABSOLUTE MAXIMUM RATINGS

Power Supply Voltage, $V_{DD}$	+4.0V
$V_{CC}$	+6.5V
Ground Voltage Differences	$\pm 0.1\text{V}$
Digital Input Voltage	$-0.3\text{V}$ to $(6.5\text{V} + 0.3\text{V})$
Input Current (except power supply)	$\pm 10\text{mA}$
Ambient Temperature Under Bias	$-40^\circ\text{C}$ to $+125^\circ\text{C}$
Storage Temperature	$-55^\circ\text{C}$ to $+150^\circ\text{C}$
Junction Temperature	$+150^\circ\text{C}$
Lead Temperature (soldering, 5s)	$+260^\circ\text{C}$
Package Temperature (IR reflow, 10s)	$+235^\circ\text{C}$



## ELECTROSTATIC DISCHARGE SENSITIVITY

This integrated circuit can be damaged by ESD. Burr-Brown recommends that all integrated circuits be handled with appropriate precautions. Failure to observe proper handling and installation procedures can cause damage.

ESD damage can range from subtle performance degradation to complete device failure. Precision integrated circuits may be more susceptible to damage because very small parametric changes could cause the device not to meet its published specifications.

## PACKAGE/ORDERING INFORMATION

PRODUCT	PACKAGE	PACKAGE DRAWING NUMBER	SPECIFIED TEMPERATURE RANGE	PACKAGE MARKING	ORDERING NUMBER <sup>(1)</sup>	TRANSPORT MEDIA
PCM1742E	SSOP-16	322	$-25^\circ\text{C}$ to $+85^\circ\text{C}$	PCM1742E	PCM1742E	Rails
"	"	"	"	"	PCM1742E/2K	Tape and Reel
PCM1742KE	SSOP-16	322	$-25^\circ\text{C}$ to $+85^\circ\text{C}$	PCM1742KE	PCM1742KE	Rails
"	"	"	"	"	PCM1742KE/2K	Tape and Reel

NOTE: (1) Models with a slash (/) are available only in Tape and Reel in the quantities indicated (e.g., /2K indicates 2000 devices per reel). Ordering 2000 pieces of "PCM1742E/2K" will yield a single 2000-piece Tape and Reel.

## BLOCK DIAGRAM

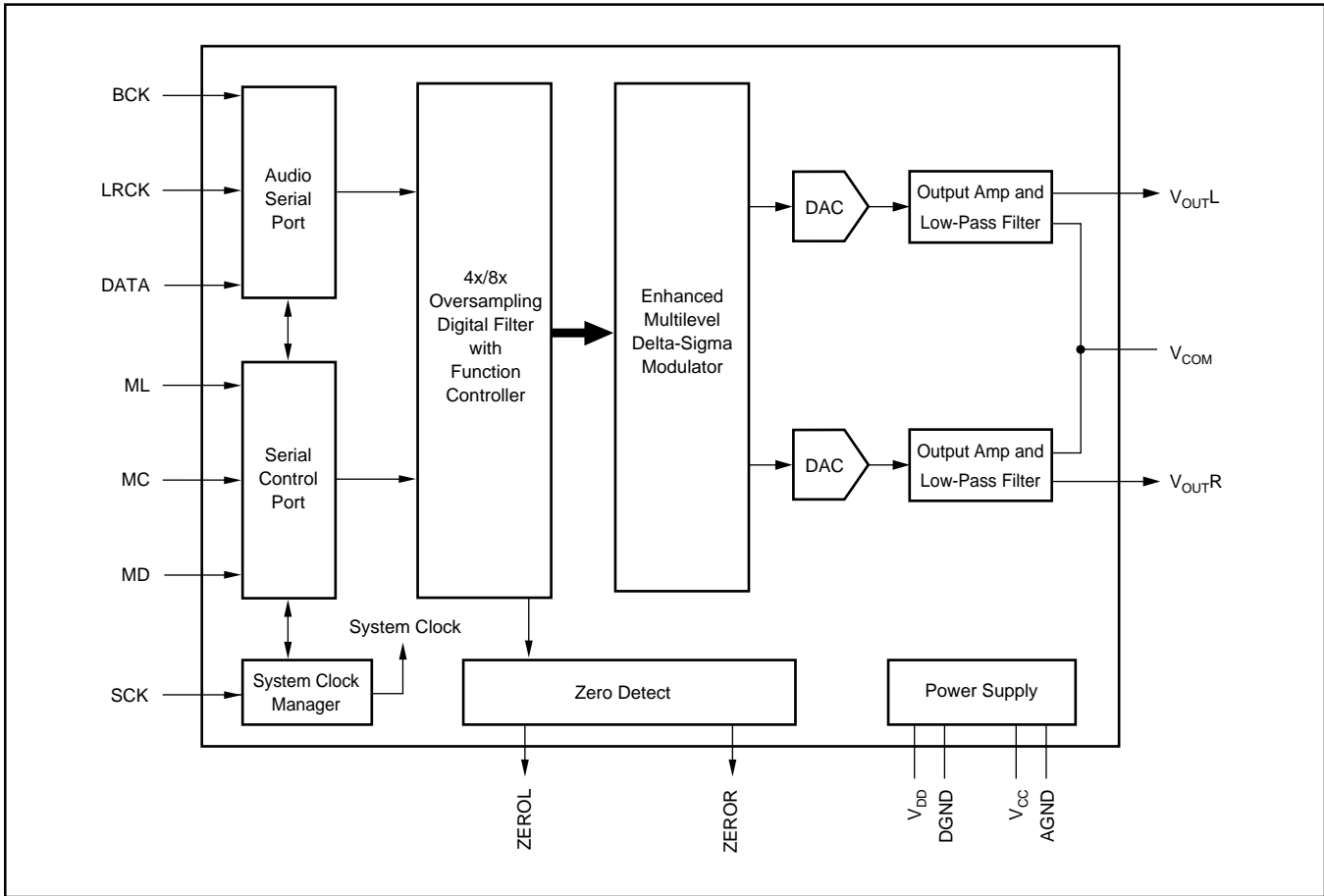

## PIN CONFIGURATION

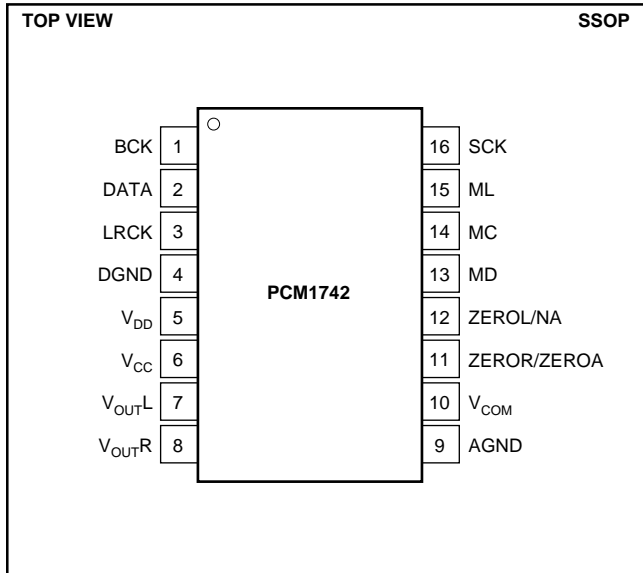

## PIN ASSIGNMENTS

PIN	NAME	TYPE	FUNCTION
1	BCK	IN	Audio Data Bit Clock Input. <sup>(1)</sup>
2	DATA	IN	Audio Data Digital Input. <sup>(1)</sup>
3	LRCK	IN	L-Channel and R-Channel Audio Data Latch Enable Input. <sup>(1)</sup>
4	DGND	–	Digital Ground
5	V <sub>DD</sub>	–	Digital Power Supply, +3.3V
6	V <sub>CC</sub>	–	Analog Power Supply, +5V
7	V <sub>OUTL</sub>	OUT	Analog Output for L-Channel.
8	V <sub>OUTR</sub>	OUT	Analog Output for R-Channel.
9	AGND	–	Analog Ground
10	V <sub>COM</sub>	–	Common Voltage Decoupling.
11	ZEROR/ ZEROA	OUT	Zero Flag Output for R-Channel/Zero Flag Output for L/R-Channel.
12	ZEROL/NA	OUT	Zero Flag Output for L-Channel/No Assign.
13	MD	IN	Mode Control Data Input. <sup>(2)</sup>
14	MC	IN	Mode Control Clock Input. <sup>(2)</sup>
15	ML	IN	Mode Control Latch Input. <sup>(2)</sup>
16	SCK	IN	System Clock Input.

NOTES: (1) Schmitt-trigger input, 5V tolerant. (2) Schmitt-trigger with internal pull-down, 5V tolerant.

# TYPICAL PERFORMANCE CURVES

All specifications at  $T_A = +25^\circ\text{C}$ ,  $V_{CC} = 5.0\text{V}$ ,  $V_{DD} = 3.3\text{V}$ , system clock =  $384f_S$  ( $f_S = 44.1\text{kHz}$ ), and 24-bit input data, unless otherwise noted.

## DIGITAL FILTER

### Digital Filter (De-Emphasis Off)

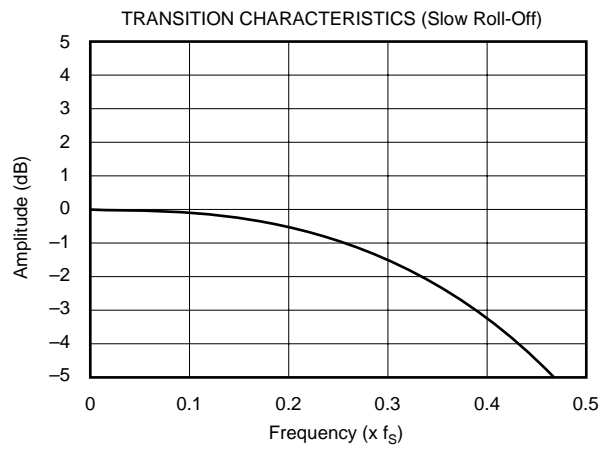
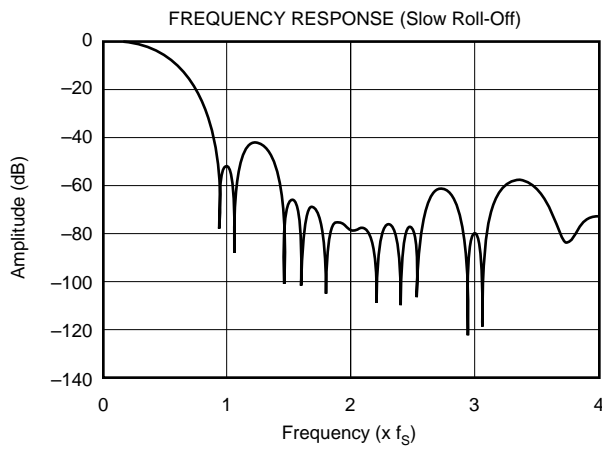
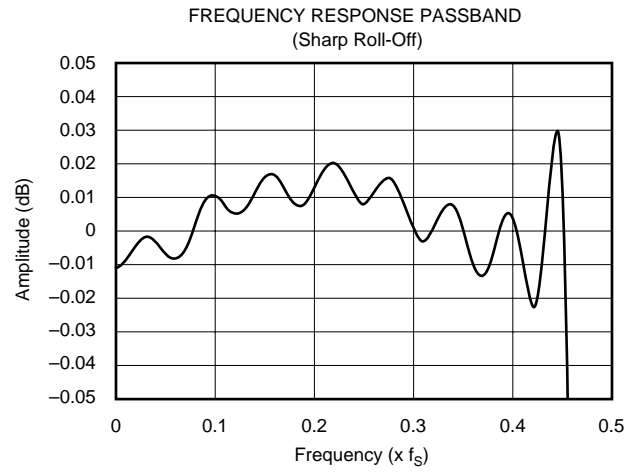
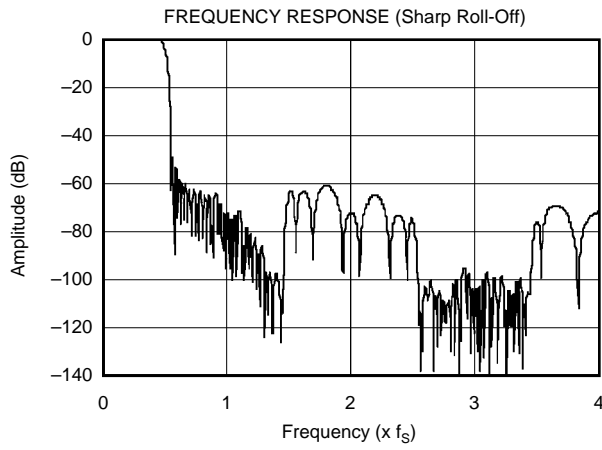

### De-Emphasis

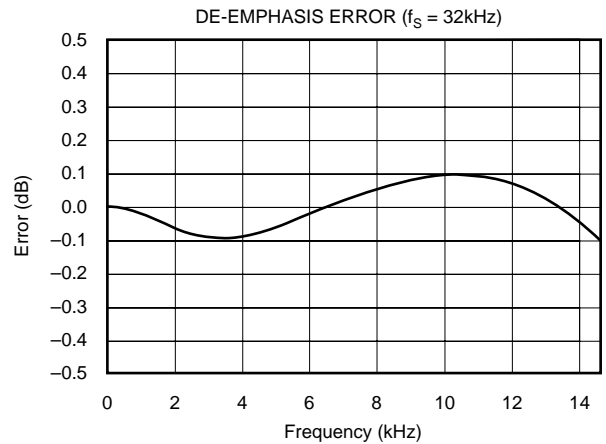
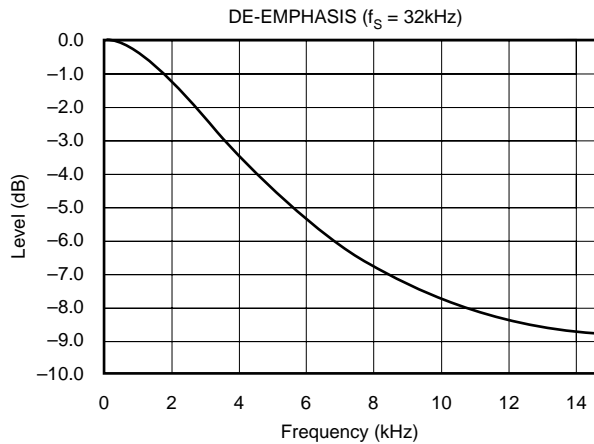

# TYPICAL PERFORMANCE CURVES (Cont.)

All specifications at  $T_A = +25^\circ\text{C}$ ,  $V_{CC} = 5.0\text{V}$ ,  $V_{DD} = 3.3\text{V}$ , system clock =  $384f_S$  ( $f_S = 44.1\text{kHz}$ ), and 24-bit input data, unless otherwise noted.

## De-Emphasis (Cont.)

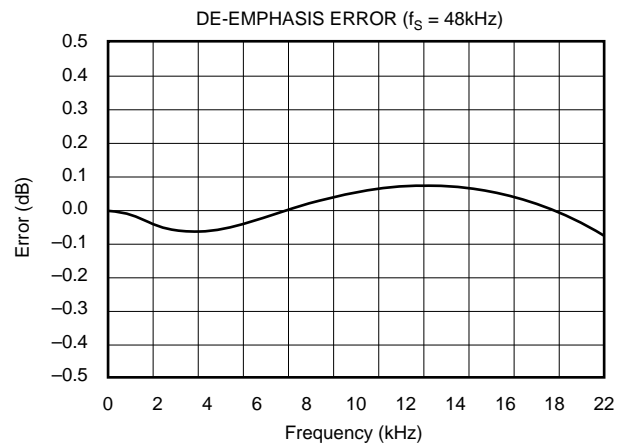
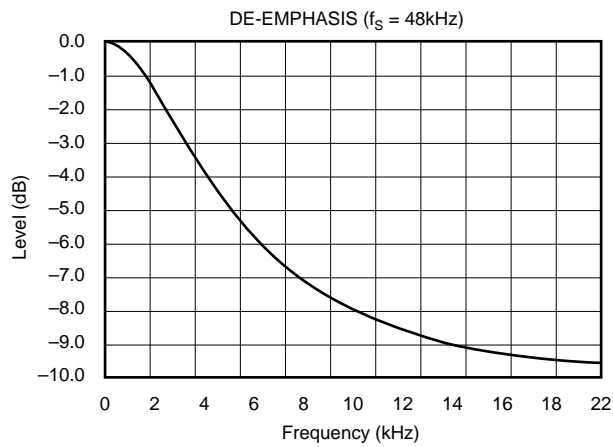
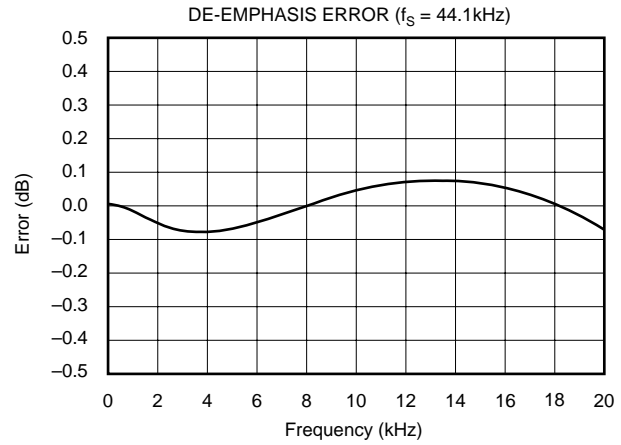
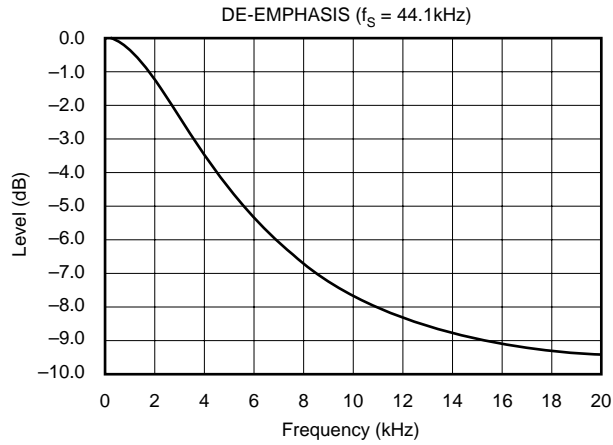

## ANALOG DYNAMIC PERFORMANCE

All specifications at  $T_A = +25^\circ\text{C}$ ,  $V_{CC} = 5.0\text{V}$ ,  $V_{DD} = 3.3\text{V}$ , and 24-bit input data, unless otherwise noted. Conditions in 192kHz operation are: system clock =  $128f_S$  and oversampling rate =  $64f_S$  of Register 18.

### Supply-Voltage Characteristics

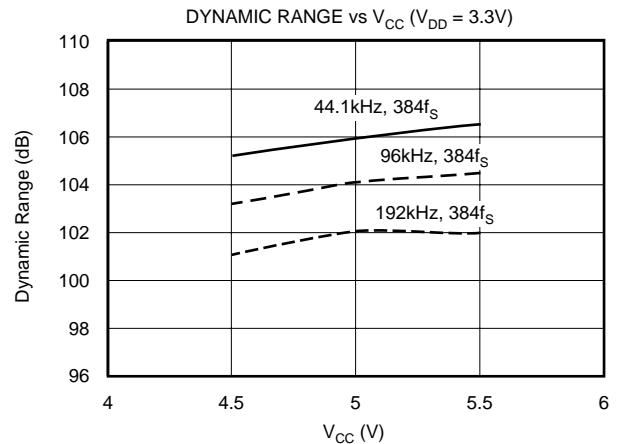
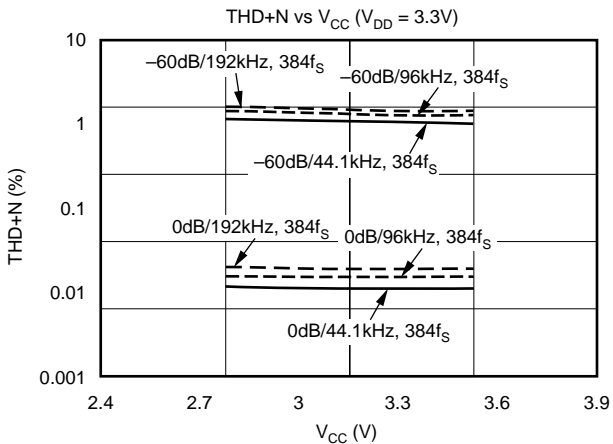

# TYPICAL PERFORMANCE CURVES (Cont.)

All specifications at  $T_A = +25^\circ\text{C}$ ,  $V_{CC} = 5.0\text{V}$ ,  $V_{DD} = 3.3\text{V}$ , and 24-bit input data, unless otherwise noted. Conditions in 192kHz operation are: system clock =  $128f_S$  and oversampling rate =  $64f_S$  of Register 18.

## Supply-Voltage Characteristics (Cont.)

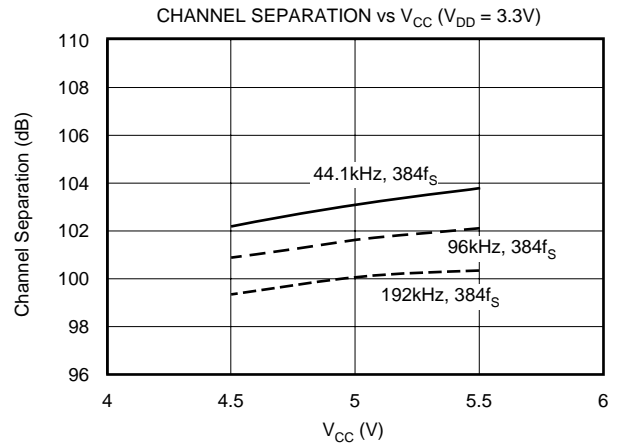
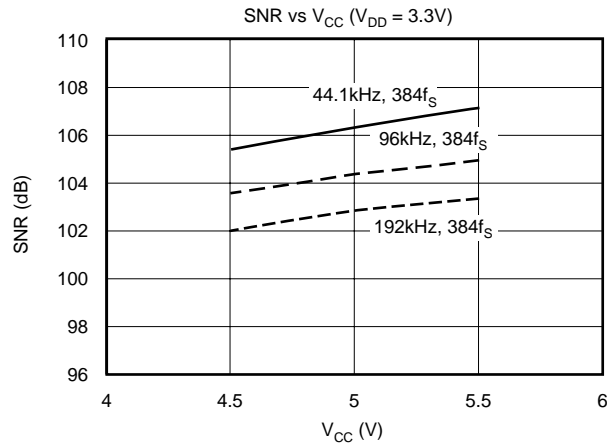

## Temperature Characteristics

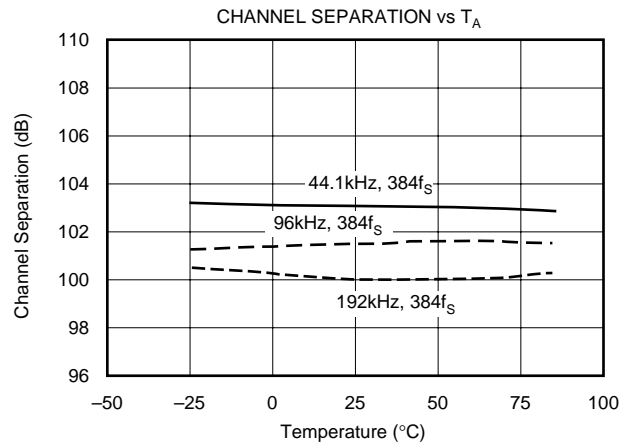
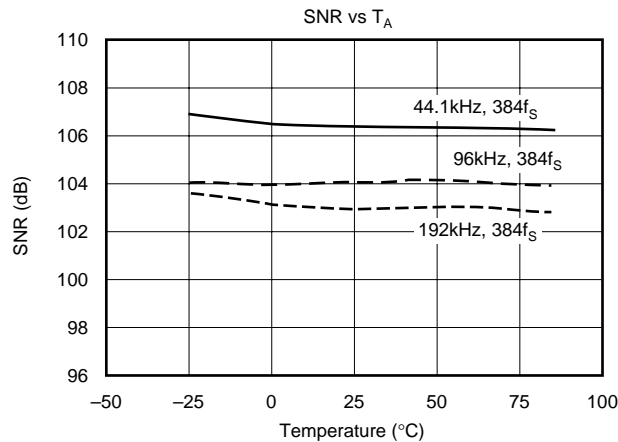
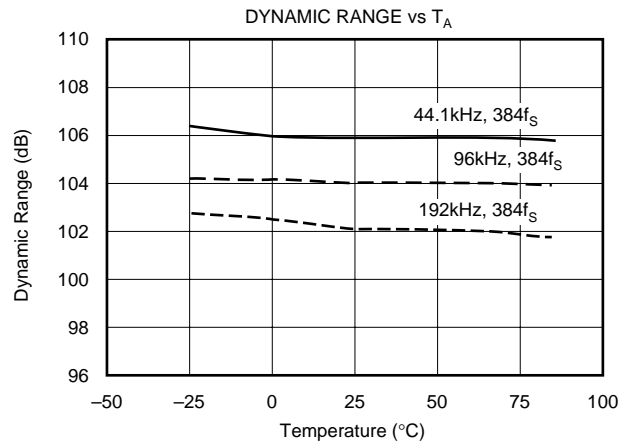
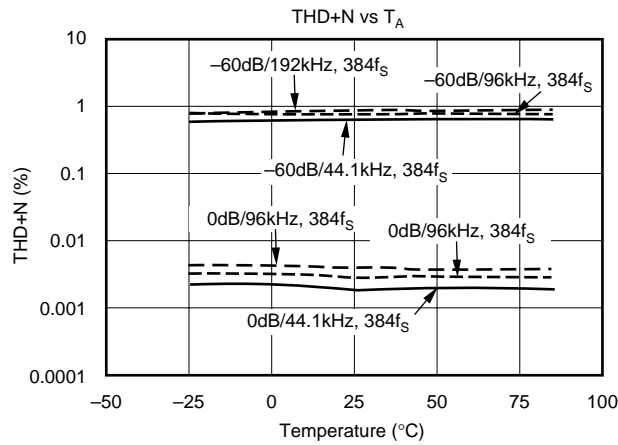

# SYSTEM CLOCK AND RESET FUNCTIONS

## SYSTEM CLOCK INPUT

The PCM1742 requires a system clock for operating the digital interpolation filters and multilevel delta-sigma modulators. The system clock is applied at the SCK input (pin 16). Table I shows examples of system clock frequencies for common audio sampling rates.

Figure 1 shows the timing requirements for the system clock input. For optimal performance, it is important to use a clock source with low phase jitter and noise. The PLL1700 multi-clock generator from Texas Instruments is an excellent choice for providing the PCM1742 system clock.

## POWER-ON RESET FUNCTIONS

The PCM1742 includes a power-on reset function, as shown in Figure 2. With the system clock active, and  $V_{DD} > 2.0V$  (typical 1.6V to 2.4V), the power-on reset function will be enabled. The initialization sequence requires 1024 system clocks from the time  $V_{DD} > 2.0V$ . After the initialization period, the PCM1742 will be set to its reset default state, as described in the Mode Control Register section of this data sheet.

During the reset period (1024 system clocks), the analog outputs are forced to the bipolar zero level, or  $V_{CC}/2$ . After the reset period, the internal register is initialized in the next  $1/f_s$  period and, if SCK, BCK, and LRCK are provided continuously, the PCM1742 provides proper analog output with unit group delay against the input data.

SAMPLING FREQUENCY	SYSTEM CLOCK FREQUENCY ( $f_{SCLK}$ ) (MHz)					
	$128f_s$	$192f_s$	$256f_s$	$384f_s$	$512f_s$	$768f_s$
8kHz	—	—	2.0480	3.0720	4.0960	6.1440
16kHz	—	—	4.0960	6.1440	8.1920	12.2880
32kHz	—	—	8.1920	12.2880	16.3840	24.5760
44.1kHz	—	—	11.2896	16.9344	22.5792	33.8688
48kHz	—	—	12.2880	18.4320	24.5760	36.8640
88.2kHz	—	—	22.5792	33.8688	45.1584	See Note (1)
96kHz	—	—	24.5760	36.8640	49.1520	See Note (1)
192kHz	24.5760	36.8640	See Note (1)	See Note (1)	See Note (1)	See Note (1)

NOTE: (1) This system clock is not supported for the given sampling frequency.

TABLE I. System Clock Rates for Common Audio Sampling Frequencies.

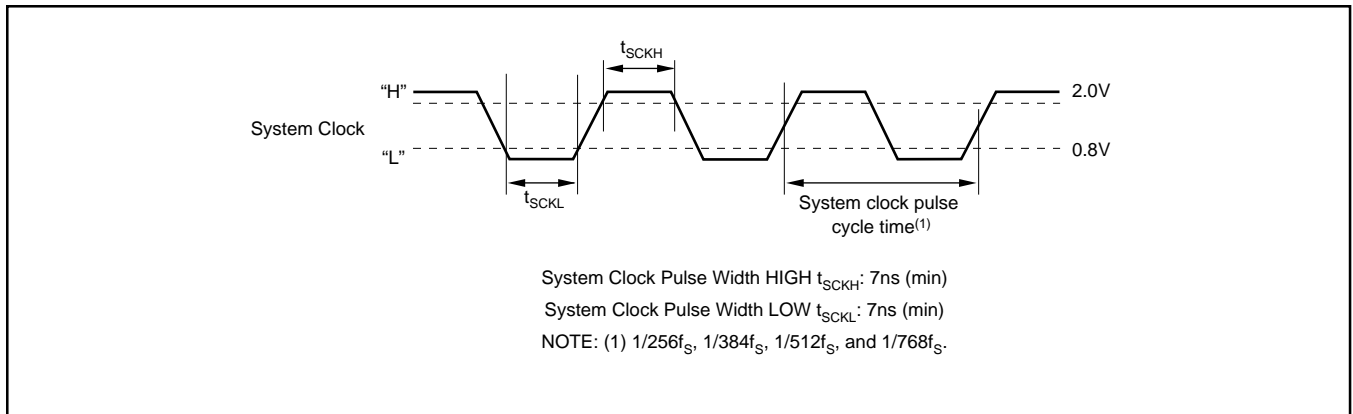

FIGURE 1. System Clock Input Timing.

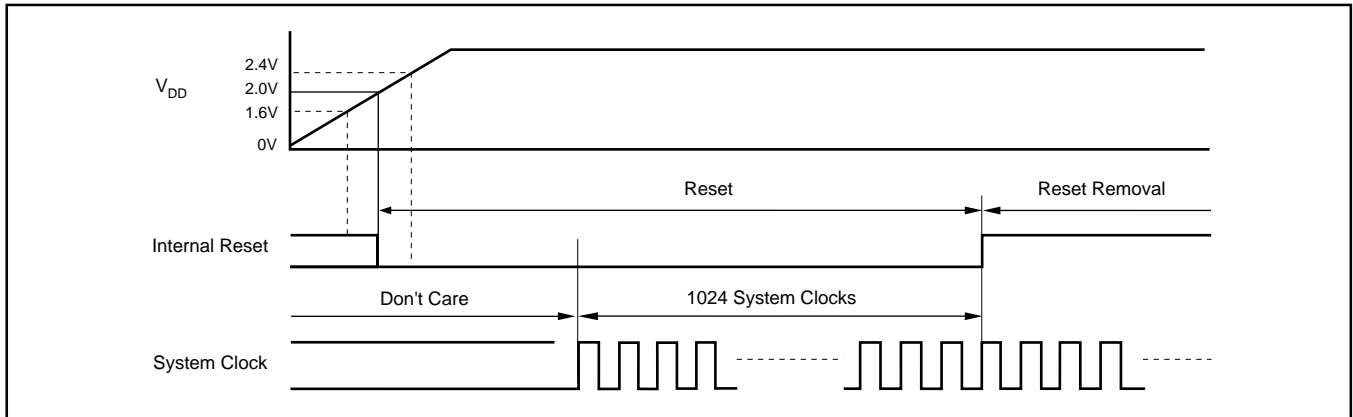

FIGURE 2. Power-On Reset Timing.

## AUDIO SERIAL INTERFACE

The audio serial interface for the PCM1742 is comprised of a 3-wire synchronous serial port. It includes LRCK (pin 3), BCK (pin 1), and DATA (pin 2). BCK is the serial audio bit clock, and is used to clock the serial data present on DATA into the audio interface's serial shift register. Serial data is clocked into the PCM1742 on the rising edge of BCK. LRCK is the serial audio left/right word clock used to latch serial data into the serial audio interface's internal registers.

Both LRCK and BCK should be synchronous to the system clock. Ideally, it is recommended that LRCK and BCK be derived from the system clock input, SCK. LRCK is operated at the sampling frequency,  $f_s$ . BCK may be operated at 32, 48, or 64 times the sampling frequency ( $I^2S$  format except  $BCK = 32f_s$ ). Internal operation of the PCM1742 is synchronized with LRCK. Accordingly, it is

held when the sampling rate clock of LRCK is changed or SCK and/or BCK is broken at least for one clock cycle. If SCK, BCK, and LRCK are provided continuously after this hold condition, the internal operation will be resynchronized automatically, less than  $3/f_s$  period. In this resynchronize period, and following  $3/f_s$ , analog output is forced to the bipolar zero level, or  $V_{CC}/2$ . External resetting is not required.

## AUDIO DATA FORMATS AND TIMING

The PCM1742 supports industry-standard audio data formats, including Standard,  $I^2S$ , and Left-Justified, as shown in Figure 3. Data formats are selected using the format bits, FMT[2:0], in Control Register 20. The default data format is 24-bit left justified. All formats require Binary Two's Complement, MSB-first audio data. See Figure 4 for a detailed timing diagram of the serial audio interface.

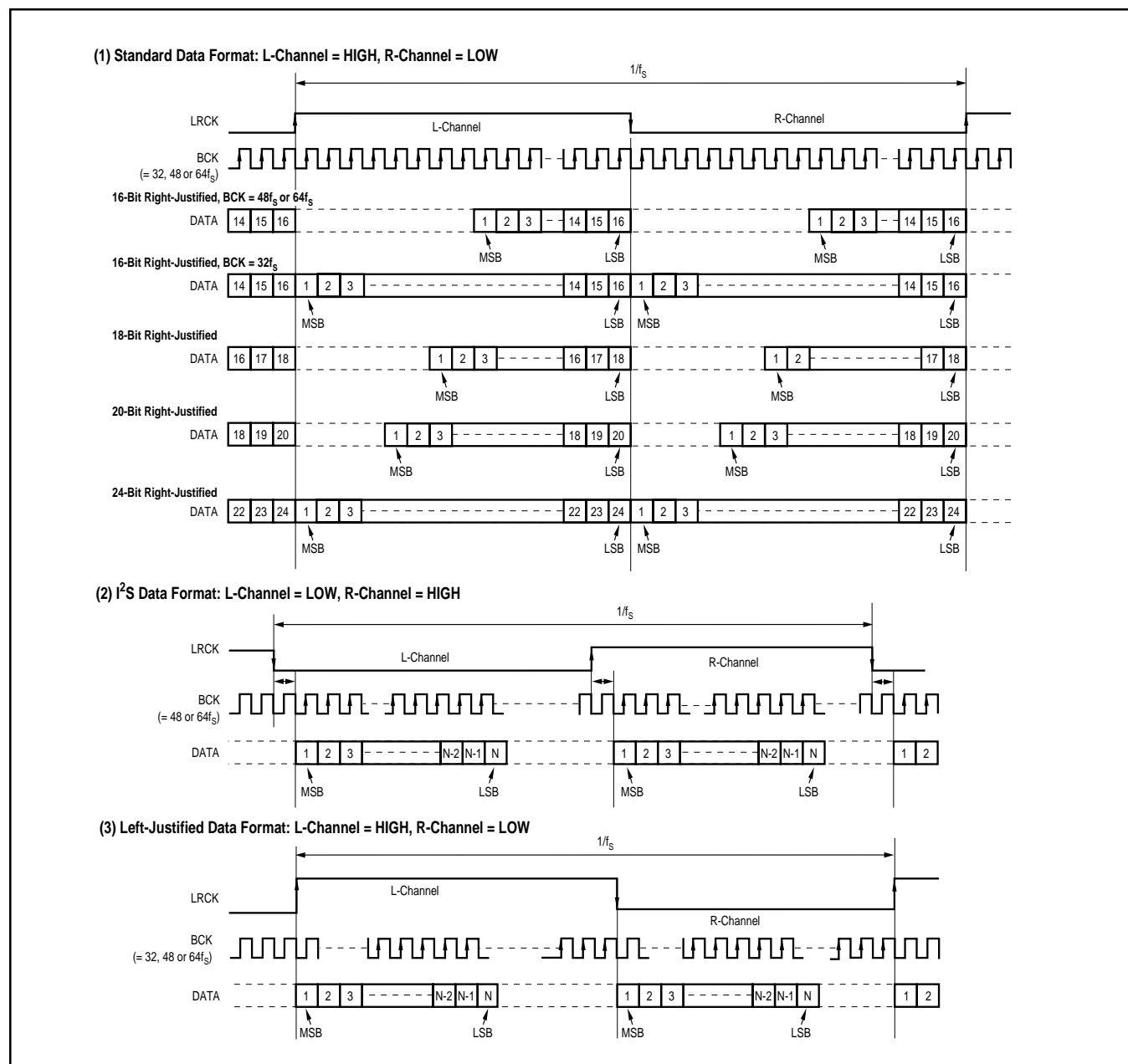

FIGURE 3. Audio Data Input Formats.

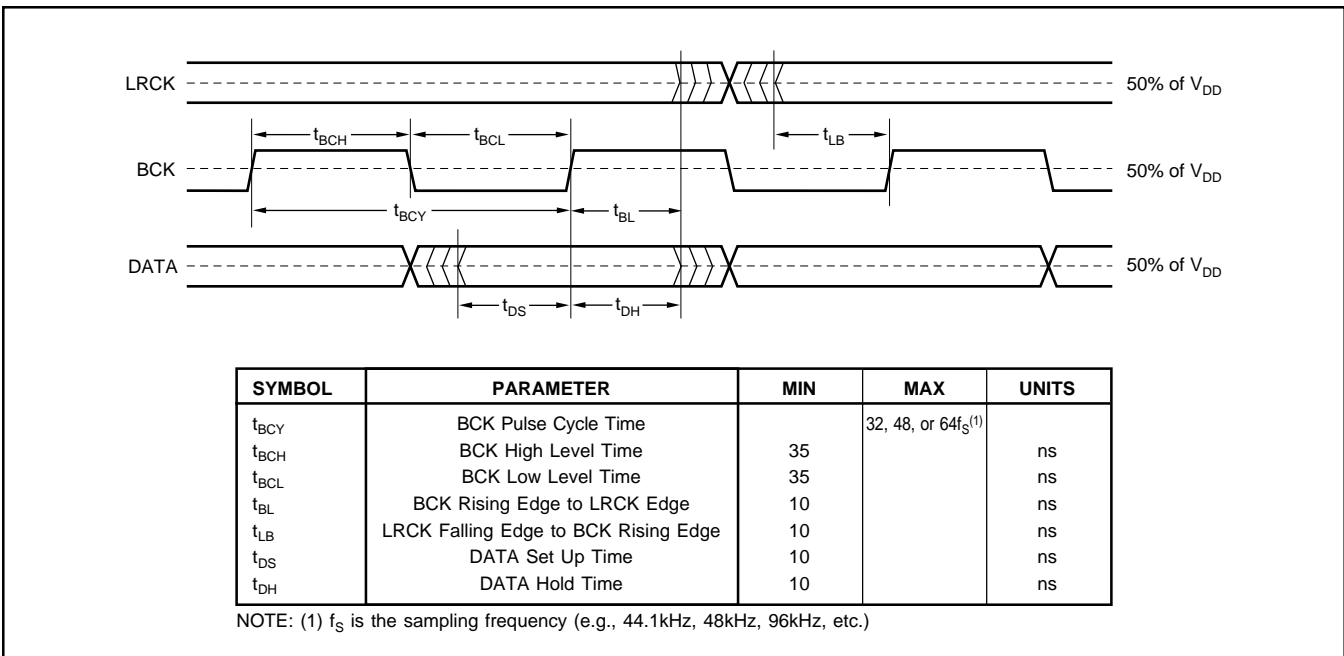

FIGURE 4. Audio Interface Timing.

### SERIAL CONTROL INTERFACE

The serial control interface is a 3-wire serial port that operates asynchronously to the serial audio interface. The serial control interface is utilized to program the on-chip mode registers. The control interface includes MD (pin 13), MC (pin 14), and ML (pin 15). MD is the serial data input, used to program the mode registers, MC is the serial bit clock, used to shift data into the control port, and ML is the control port latch clock.

### REGISTER WRITE OPERATION

All write operations for the serial control port use 16-bit data words. Figure 5 shows the control data word format. The most significant bit must be a "0". There are seven bits, labeled  $IDX[6:0]$ , that set the register index (or address) for

the write operation. The least significant eight bits,  $D[7:0]$ , contain the data to be written to the register specified by  $IDX[6:0]$ .

Figure 6 shows the functional timing diagram for writing the serial control port. ML is held at a logic "1" state until a register needs to be written. To start the register write cycle, ML is set to logic "0". Sixteen clocks are then provided on MC, corresponding to the 16 bits of the control data word on MD. After the sixteenth clock cycle has completed, ML is set to logic "1" to latch the data into the indexed mode control register.

### CONTROL INTERFACE TIMING REQUIREMENTS

See Figure 7 for a detailed timing diagram of the serial control interface. These timing parameters are critical for proper control port operation.

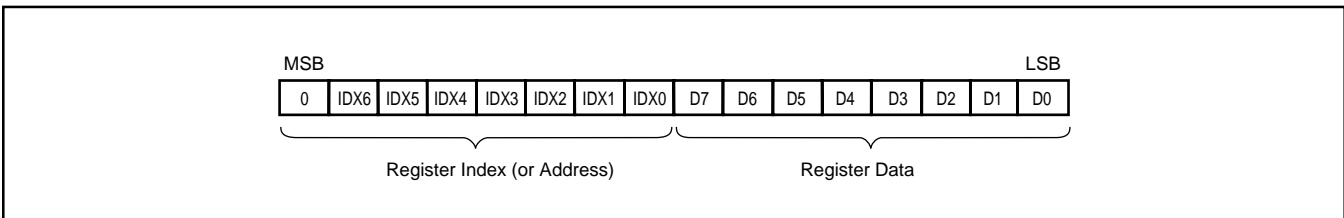

FIGURE 5. Control Data Word Format for MDI.

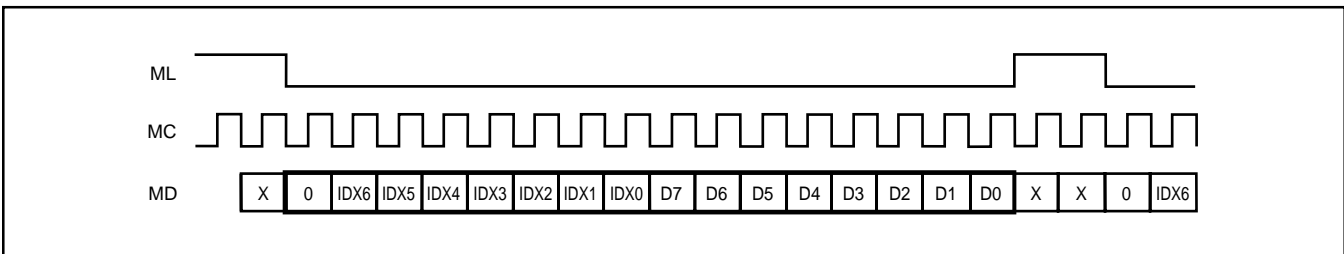

FIGURE 6. Register Write Operation.

## MODE CONTROL REGISTERS

### User-Programmable Mode Controls

The PCM1742 includes a number of user-programmable functions that are accessed via control registers. The registers are programmed using the Serial Control Interface that was previously discussed in this data sheet. Table II lists the

available mode control functions, along with their reset default conditions and associated register index.

### Register Map

The mode control register map is shown in Table III. Each register includes an index (or address) indicated by the IDX[6:0] bits.

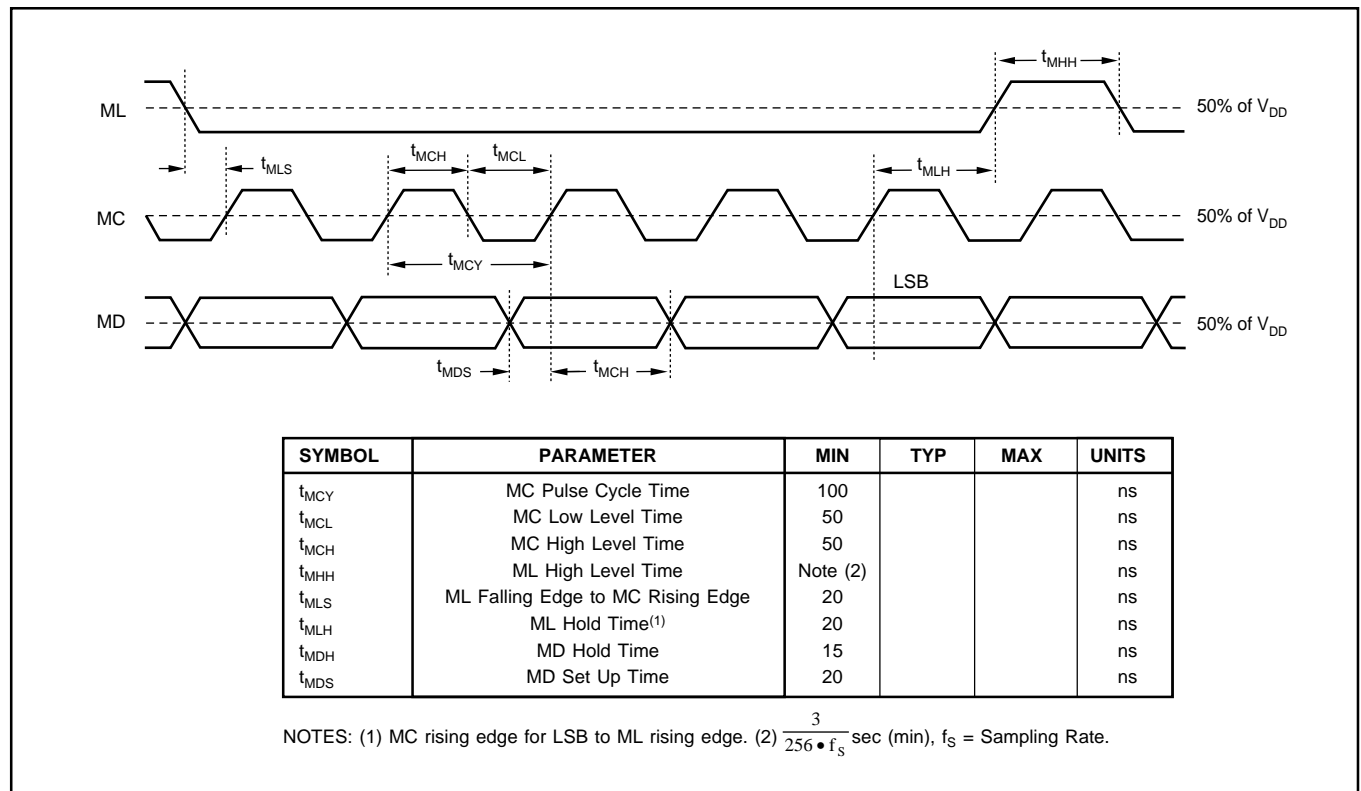

FIGURE 7. Control Interface Timing.

FUNCTION	RESET DEFAULT	CONTROL REGISTER	INDEX, IDX[6:0]
Digital Attenuation Control, 0dB to -63dB in 0.5dB Steps	0dB, No Attenuation	16 and 17	AT1[7:0], AT2[7:0]
Soft Mute Control	Mute Disabled	18	MUT[2:0]
Oversampling Rate Control (64 or 128 $f_s$ )	64 $f_s$ Oversampling	18	OVER
DAC Operation Control	DAC1 and DAC2 Enabled	19	DAC[2:1]
De-Emphasis Function Control	De-Emphasis Disabled	19	DM12
De-Emphasis Sample Rate Selection	44.1kHz	19	DMF[1:0]
Audio Data Format Control	24-Bit Left Justified	20	FMT[2:0]
Digital Filter Roll-Off Control	Sharp Roll-Off	20	FLT
Zero Flag Function Select	L-/R-Channel Independent	22	AZRO
Output Phase Select	Normal Phase	22	DREV
Zero Flag Polarity Select	High	22	ZREV

TABLE II. User-Programmable Mode Controls.

IDX (B8-B14)	REGISTER	B15	B14	B13	B12	B11	B10	B9	B8	B7	B6	B5	B4	B3	B2	B1	B0
10 <sub>H</sub>	16	0	IDX6	IDX5	IDX4	IDX3	IDX2	IDX1	IDX0	AT17	AT16	AT15	AT14	AT13	AT12	AT11	AT10
11 <sub>H</sub>	17	0	IDX6	IDX5	IDX4	IDX3	IDX2	IDX1	IDX0	AT27	AT26	AT25	AT24	AT23	AT22	AT21	AT20
12 <sub>H</sub>	18	0	IDX6	IDX5	IDX4	IDX3	IDX2	IDX1	IDX0	RSV	OVER	RSV	RSV	RSV	RSV	MUT2	MUT1
13 <sub>H</sub>	19	0	IDX6	IDX5	IDX4	IDX3	IDX2	IDX1	IDX0	RSV	DMF1	DMF0	DM12	RSV	RSV	DAC2	DAC1
14 <sub>H</sub>	20	0	IDX6	IDX5	IDX4	IDX3	IDX2	IDX1	IDX0	RSV	RSV	FLT	RSV	RSV	FMT2	FMT1	FMT0
15 <sub>H</sub>	21	0	IDX6	IDX5	IDX4	IDX3	IDX2	IDX1	IDX0	RSV	RSV	RSV	RSV	RSV	RSV	RSV	RSV
16 <sub>H</sub>	22	0	IDX6	IDX5	IDX4	IDX3	IDX2	IDX1	IDX0	RSV	RSV	RSV	RSV	RSV	AZRO	ZREV	DREV

TABLE III. Mode Control Register Map.

## REGISTER DEFINITIONS

	B15	B14	B13	B12	B11	B10	B9	B8	B7	B6	B5	B4	B3	B2	B1	B0
Register 16	0	IDX6	IDX5	IDX4	IDX3	IDX2	IDX1	IDX0	AT17	AT16	AT15	AT14	AT13	AT12	AT11	AT10
Register 17	0	IDX6	IDX5	IDX4	IDX3	IDX2	IDX1	IDX0	AT27	AT26	AT25	AT24	AT23	AT22	AT21	AT20

### ATx[7:0] Digital Attenuation Level Setting

where  $x = 1$  or  $2$ , corresponding to the DAC output  $V_{OUTL}$  ( $x = 1$ ) and  $V_{OUTR}$  ( $x = 2$ ).

Default Value: 1111 1111<sub>B</sub>

Each DAC channel ( $V_{OUTL}$  and  $V_{OUTR}$ ) includes a digital attenuator function. The attenuation level may be set from 0dB to -63dB, in 0.5dB steps. Changes in attenuation levels are made by incrementing or decrementing, by one step (0.5dB), for every  $8/f_s$  time interval until the programmed attenuator setting is reached. Alternatively, the attenuation level may be set to infinite attenuation, or mute. The attenuation data for each channel can be set individually.

The attenuation level may be set using the formula below.

$$\text{Attenuation Level (dB)} = 0.5 (\text{ATx}[7:0]_{\text{DEC}} - 255)$$

where:  $\text{ATx}[7:0]_{\text{DEC}} = 0$  through 255

for:  $\text{ATx}[7:0]_{\text{DEC}} = 0$  through 128, the attenuator is set to infinite attenuation.

The following table shows attenuator levels for various settings.

ATx[7:0]	Decimal Value	Attenuator Level Setting
1111 1111 <sub>B</sub>	255	0dB, No Attenuation (default)
1111 1110 <sub>B</sub>	254	-0.5dB
1111 1101 <sub>B</sub>	253	-1.0dB
1000 0011 <sub>B</sub>	131	-62.0dB
1000 0010 <sub>B</sub>	130	-62.5dB
1000 0001 <sub>B</sub>	129	-63.0dB
1000 0000 <sub>B</sub>	128	Mute
.	.	.
.	.	.
.	.	.
0000 0000 <sub>B</sub>	0	Mute

	B15	B14	B13	B12	B11	B10	B9	B8	B7	B6	B5	B4	B3	B2	B1	B0
Register 18	0	IDX6	IDX5	IDX4	IDX3	IDX2	IDX1	IDX0	RSV	OVER	RSV	RSV	RSV	RSV	MUT2	MUT1

### MUTx Soft Mute Control

Where  $x = 1$  or  $2$ , corresponding to the DAC output  $V_{OUTL}$  ( $x = 1$ ) and  $V_{OUTR}$  ( $x = 2$ ).

Default Value: 0

MUTx = 0	Mute Disabled (default)
MUTx = 1	Mute Enabled

The Mute bits, MUT1 and MUT2, are used to enable or disable the Soft Mute function for the corresponding DAC outputs,  $V_{OUTL}$  and  $V_{OUTR}$ . The Soft Mute function is incorporated into the digital attenuators. When Mute is disabled ( $\text{MUTx} = 0$ ), the attenuator and DAC operate normally. When Mute is enabled by setting  $\text{MUTx} = 1$ , the digital attenuator for the corresponding output will be decreased from the current setting to the infinite attenuation setting one attenuator step (0.5dB) at a time. This provides a “pop”-free muting of the DAC output.

### OVER Oversampling Rate Control

Default Value: 0

OVER = 0	64x Oversampling (default)
OVER = 1	128x Oversampling

The OVER bit is used to control the oversampling rate of the delta-sigma DACs. The  $\text{OVER} = 1$  setting is recommended when the oversampling rate is 192kHz (system clock is 128 or  $192f_s$ ).

	B15	B14	B13	B12	B11	B10	B9	B8	B7	B6	B5	B4	B3	B2	B1	B0
REGISTER 19	0	IDX6	IDX5	IDX4	IDX3	IDX2	IDX1	IDX0	RSV	DMF1	DMF0	DM12	RSV	RSV	DAC2	DAC1

### DACx DAC Operation Control

where  $x = 1$  or  $2$ , corresponding to the DAC output  $V_{OUTL}$  ( $x = 1$ ) or  $V_{OUTR}$  ( $x = 2$ ).

Default Value: 0

DACx = 0	DAC Operation Enabled (default)
DACx = 1	DAC Operation Disabled

The DAC operation controls are used to enable and disable the DAC outputs,  $V_{OUTL}$  and  $V_{OUTR}$ . When  $DACx = 0$ , the corresponding output will generate the audio waveform dictated by the data present on the DATA pin. When  $DACx = 1$ , the corresponding output will be set to the bipolar zero level, or  $V_{CC}/2$ .

### DM12 Digital De-Emphasis Function Control

Default Value: 0

DM12 = 0	De-Emphasis Disabled (default)
DM12 = 1	De-Emphasis Enabled

The DM12 bit is used to enable or disable the Digital De-Emphasis function. Refer to the Typical Performance Curves of this data sheet for more information.

### DMF[1:0] Sampling Frequency Selection for the De-Emphasis Function

Default Value: 00

DMF[1:0]	De-Emphasis Same Rate Selection
00	44.1kHz (default)
01	48kHz
10	32kHz
11	Reserved

The DMF[1:0] bits are used to select the sampling frequency used for the Digital De-Emphasis function when it is enabled.

	B15	B14	B13	B12	B11	B10	B9	B8	B7	B6	B5	B4	B3	B2	B1	B0
REGISTER 20	0	IDX6	IDX5	IDX4	IDX3	IDX2	IDX1	IDX0	RSV	RSV	FLT	RSV	RSV	FMT2	FMT1	FMT0

### FMT[2:0] Audio Interface Data Format

Default Value: 101

The FMT[2:0] bits are used to select the data format for the serial audio interface. The following table shows the available format options.

FMT[2:0]	Audio Data Format Selection
000	24-Bit Standard Format, Right-Justified Data
001	20-Bit Standard Format, Right-Justified Data
010	18-Bit Standard Format, Right-Justified Data
011	16-Bit Standard Format, Right-Justified Data
100	I <sup>2</sup> S Format, 16- to 24-bits
101	Left-Justified Format, 16- to 24-Bits (default)
110	Reserved
111	Reserved

## Register 20 (Cont.)

### FLT Digital Filter Roll-Off Control

Default Value: 0

FLT = 0	Sharp Roll-Off (default)
FLT = 1	Slow Roll-Off

The FLT bit allows the user to select the digital filter roll-off that is best suited to their application. Two filter roll-off selections are available: Sharp or Slow. The filter responses for these selections are shown in the Typical Performance Curves section of this data sheet.

	B15	B14	B13	B12	B11	B10	B9	B8	B7	B6	B5	B4	B3	B2	B1	B0
REGISTER 22	0	IDX6	IDX5	IDX4	IDX3	IDX2	IDX1	IDX0	RSV	RSV	RSV	RSV	RSV	AZRO	ZREV	DREV

### DREV Output Phase Select

Default Value: 0

DREV = 0	Normal Output (default)
DREV = 1	Inverted Output

The DREV bit is used to set the output phase of  $V_{OUTL}$  and  $V_{OUTR}$ .

### ZREV Zero Flag Polarity Select

Default Value: 0

ZREV = 0	Zero Flag Pins HIGH at a Zero Detect (default)
ZREV = 1	Zero Flag Pins LOW at a Zero Detect

The ZREV bit allows the user to select the active polarity of Zero Flag pins.

### AZRO Zero Flag Function Select

Default Value: 0<sub>H</sub>

AZRO = 0	L-/R-Channel Independent Zero Flag (default)
AZRO = 1	L-/R-Channel Common Zero Flag

The AZRO bit allows the user to select the function of Zero Flag pins.

AZRO = 0:

Pin11: ZEROR; Zero Flag Output for R-Channel
Pin12: ZEROL; Zero Flag Output for L-Channel

AZRO = 1:

Pin11: ZEROA; Zero Flag Output for L-/R-Channel
Pin12: NA; No Assign

# ANALOG OUTPUTS

The PCM1742 includes two independent output channels:  $V_{OUTL}$  and  $V_{OUTR}$ . These are unbalanced outputs, each capable of driving 3.1Vp-p typical into a 5k $\Omega$  AC-coupled load. The internal output amplifiers for  $V_{OUTL}$  and  $V_{OUTR}$  are biased to the DC common-mode (or bipolar zero) voltage, equal to  $V_{CC}/2$ .

The output amplifiers include an RC continuous-time filter that helps to reduce the out-of-band noise energy present at the DAC outputs, due to the noise shaping characteristics of the PCM1742's delta-sigma DACs. The frequency response of this filter is shown in Figure 8. By itself, this filter is not

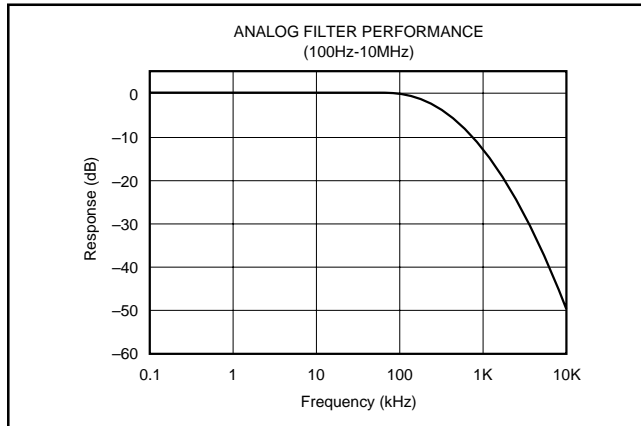

FIGURE 8. Output Filter Frequency Response.

enough to attenuate the out-of-band noise to an acceptable level for many applications, therefore, an external low-pass filter is required to provide sufficient out-of-band noise rejection. Further discussion of DAC post-filter circuits is provided in the Applications Information section of this data sheet.

## $V_{COM}$ OUTPUT

One unbuffered common-mode voltage output pin,  $V_{COM}$  (pin 10), is brought out for decoupling purposes. This pin is nominally biased to a DC voltage level equal to  $V_{CC}/2$ . This pin may be used to bias external circuits. An example of using the  $V_{COM}$  pin for external biasing applications is shown in Figure 9.

## ZERO FLAGS

### Zero Detect Condition

Zero Detection for each output channel is independent from the other. If the data for a given channel remains at a "0" level for 1024 sample periods (or LRCK clock periods), a Zero Detect condition exists for that channel.

### Zero Output Flags

Given that a Zero Detect condition exists for one or more channels, the Zero Flag pins for those channels will be set to a logic "1" state. There are Zero Flag pins for each channel: ZEROL (pin 12) and ZEROR (pin 11). These pins can be used

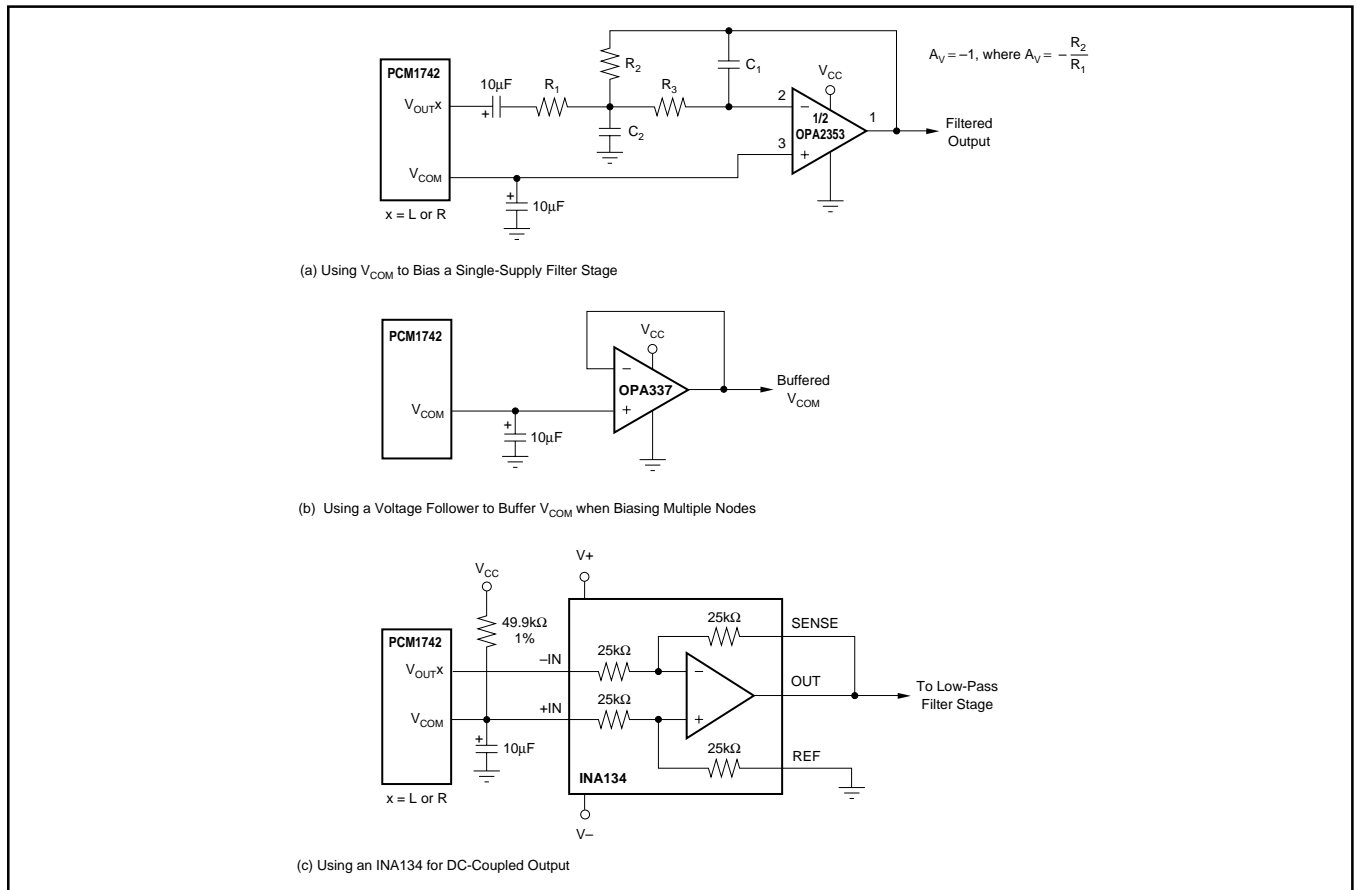

FIGURE 9. Biasing External Circuits Using the  $V_{COM}$  Pin.

to operate external mute circuits, or used as status indicators for a microcontroller, audio signal processor, or other digitally controlled functions.

The active polarity of Zero Flag output can be inverted by setting the ZREV bit of Control Register 22 to “1”. The reset default is active high output, or ZREV = 0.

The L-channel and R-channel common Zero Flag can be selected by setting the AZRO bit of Control Register 22 to “1”. The reset default is L-channel and R-channel independent Zero Flag, or AZRO = 0.

## APPLICATIONS INFORMATION

### CONNECTION DIAGRAMS

A basic connection diagram is shown in Figure 11, with the necessary power-supply bypassing and decoupling components. Texas Instruments recommends using the component values shown in Figure 11 for all designs.

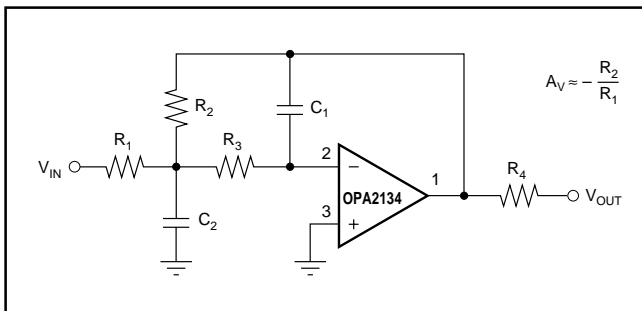

FIGURE 10. Dual-Supply Filter Circuit.

The use of series resistors (22Ω to 100Ω) are recommended for the SCK, LRCK, BCK, and DATA inputs. The series resistor combines with stray PCB and device input capacitance to form a low-pass filter that reduces high-frequency noise emissions and helps to dampen glitches and ringing present on clock and data lines.

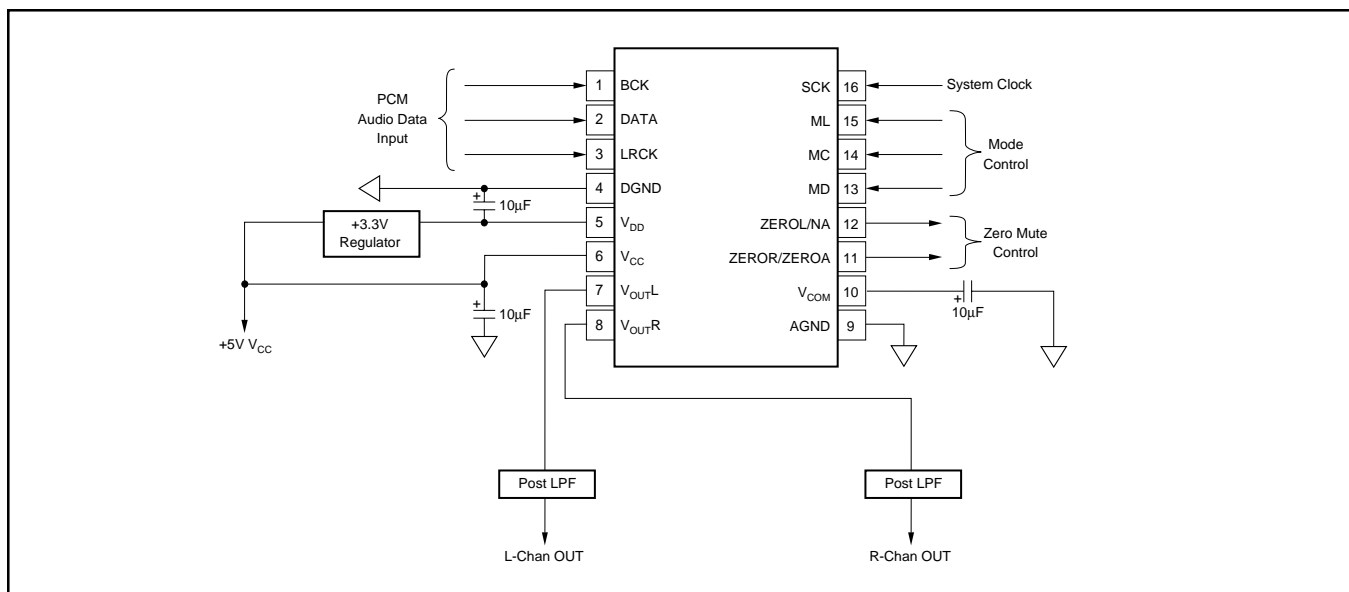

FIGURE 11. Basic Connection Diagram.

## POWER SUPPLIES AND GROUNDING

The PCM1742 requires a +5V analog supply ( $V_{CC}$ ) and a +3.3V digital supply ( $V_{DD}$ ). The +5V supply ( $V_{CC}$ ) is used to power the DAC analog and output filter circuitry, while the +3.3V ( $V_{DD}$ ) supply is used to power the digital filter and serial interface circuitry. For best performance, the +3.3V ( $V_{DD}$ ) supply should be derived from the +5V ( $V_{CC}$ ) supply using a linear regulator, as shown in Figure 11. The REG1117-3.3 from Texas Instruments is an ideal choice for this application.

Proper power-supply bypassing is shown in Figure 11. The 10µF capacitors should be tantalum or aluminum electrolytic.

### DAC OUTPUT FILTER CIRCUITS

Delta-sigma DACs utilize noise-shaping techniques to improve in-band Signal-to-Noise Ratio (SNR) performance at the expense of generating increased out-of-band noise above the Nyquist Frequency, or  $f_s/2$ . The out-of-band noise must be low-pass filtered in order to provide the optimal converter performance. This is accomplished by a combination of on-chip and external low-pass filtering.

Figures 9(a) and 10 show the recommended external low-pass active filter circuits for single- and dual-supply applications. These circuits are second-order Butterworth filters using a Multiple FeedBack (MFB) circuit arrangement that reduces sensitivity to passive component variations over frequency and temperature. For more information regarding MFB active filter design, please refer to Burr-Brown Applications Bulletin #34 AB-034 (SBFA001), available from our web site at <http://www.ti.com>.

Since the overall system performance is defined by the quality of the DACs and their associated analog output circuitry, high-quality audio op amps are recommended for the active filters. The OPA2353 and OPA2134 dual op amps from Texas Instruments are recommended for use with the PCM1742, see Figures 9(a) and 10.

# PCB LAYOUT GUIDELINES

A typical PCB floor plan for the PCM1742 is shown in Figure 12. A ground plane is recommended, with the analog and digital sections being isolated from one another using a split or cut in the circuit board. The PCM1742 should be oriented with the digital I/O pins facing the ground plane split/cut to allow for short, direct connections to the digital audio interface and control signals originating from the digital section of the board.

Separate power supplies are recommended for the digital and analog sections of the board. This prevents the switching noise present on the digital supply from contaminating the analog power supply and degrading the dynamic performance of the PCM1742. In cases where a common +5V supply must be used for the analog and digital sections, an inductance (RF choke, ferrite bead) should be placed between the analog and digital +5V supply connections to avoid coupling of the digital switching noise into the analog circuitry. Figure 13 shows the recommended approach for single-supply applications.

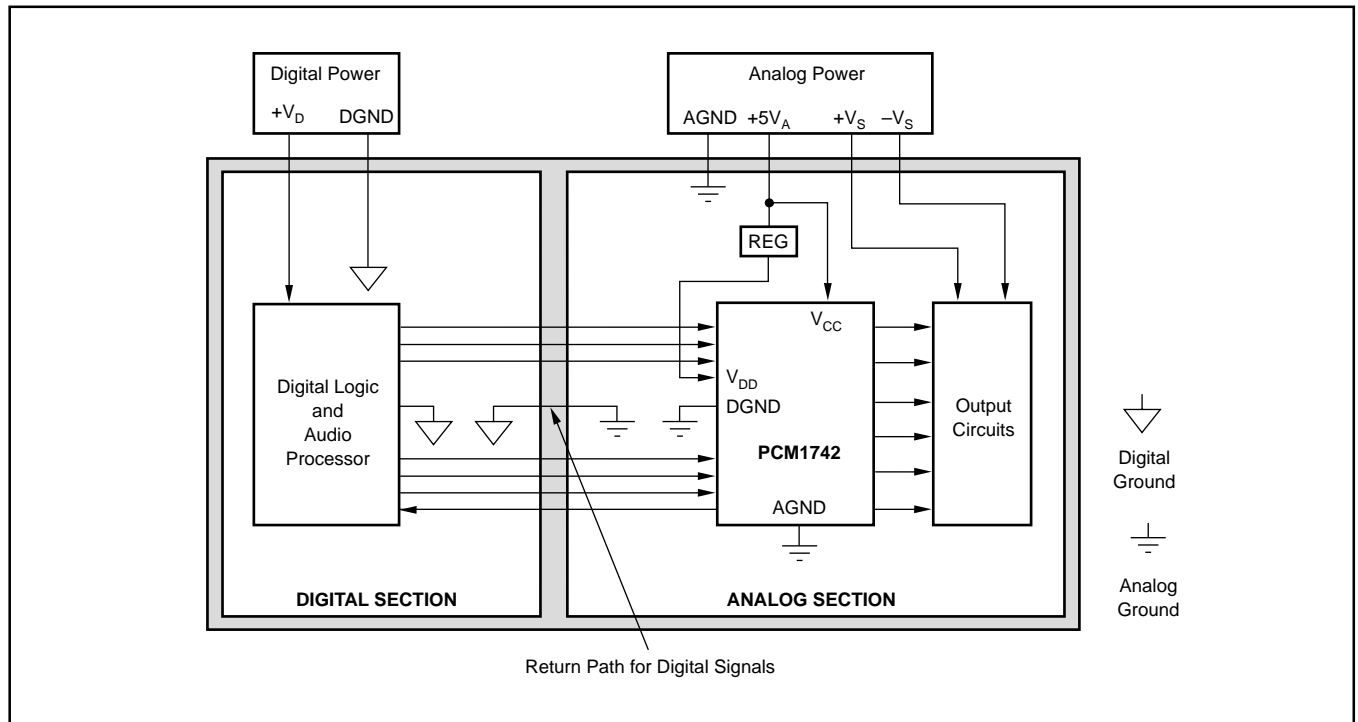

FIGURE 12. Recommended PCB Layout.

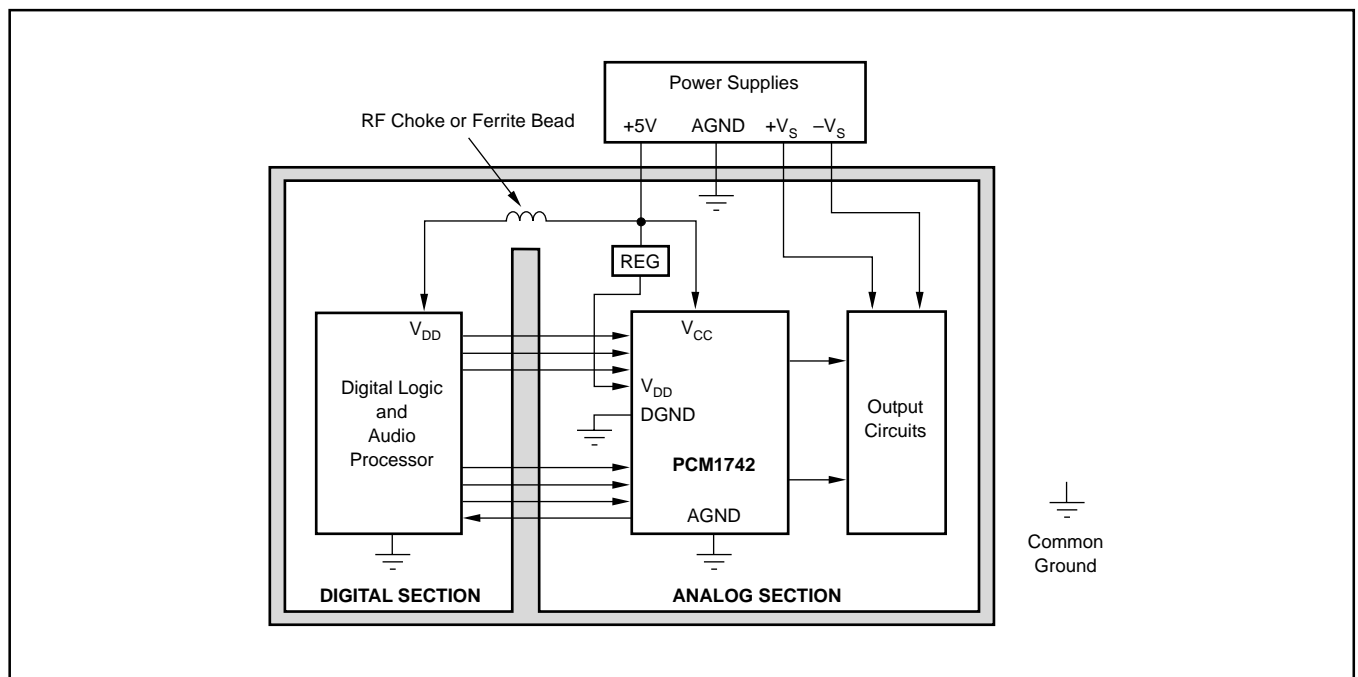

FIGURE 13. Single-Supply PCB Layout.

# THEORY OF OPERATION

The delta-sigma section of the PCM1742 is based on an 8-level amplitude quantizer and a fourth-order noise shaper. This section converts the oversampled input data to 8-level delta-sigma format. A block diagram of the 8-level delta-sigma modulator is shown in Figure 14. This 8-level delta-sigma modulator has the advantage of stability and clock jitter sensitivity over the typical

one-bit (2-level) delta-sigma modulator. The combined oversampling rate of the delta-sigma modulator and the interpolation filter is  $64f_s$ .

The theoretical quantization noise performance of the 8-level delta-sigma modulator is shown in Figure 15. The enhanced multilevel delta-sigma architecture also has advantages for input clock jitter sensitivity due to the multilevel quantizer, with the simulated jitter sensitivity, as shown in Figure 16.

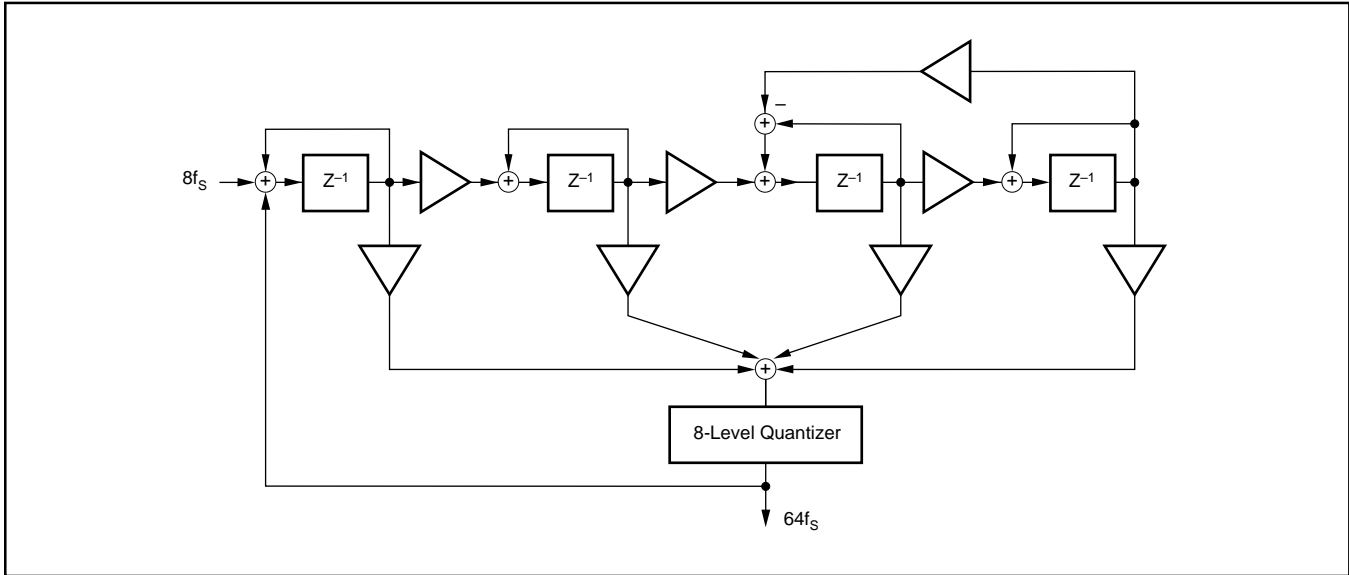

FIGURE 14. 8-Level Delta-Sigma Modulator.

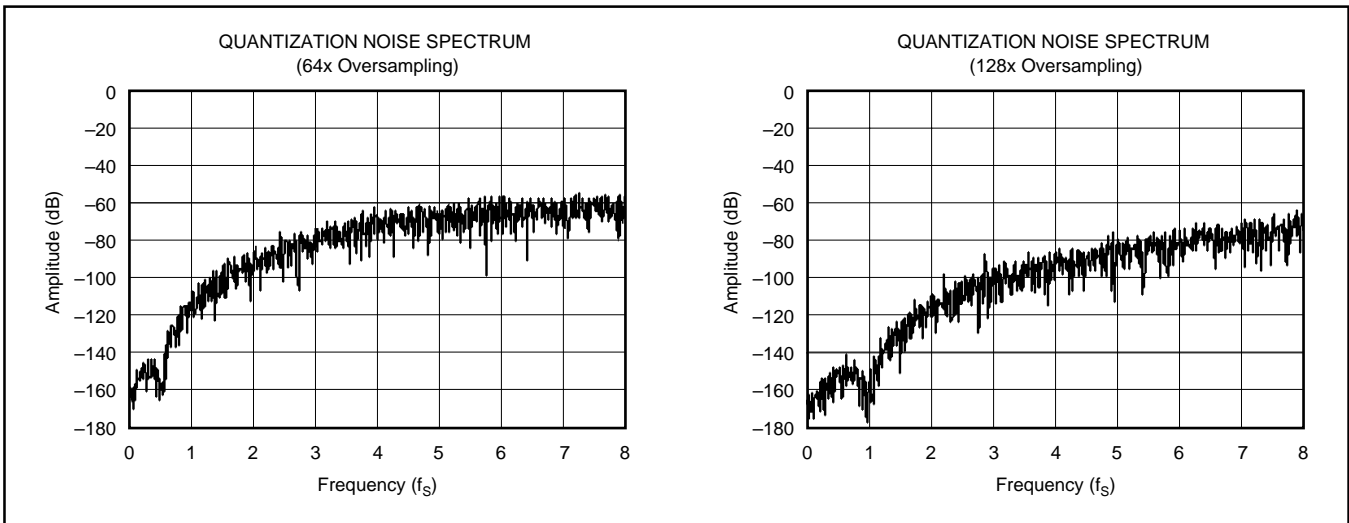

FIGURE 15. Quantization Noise Spectrum.

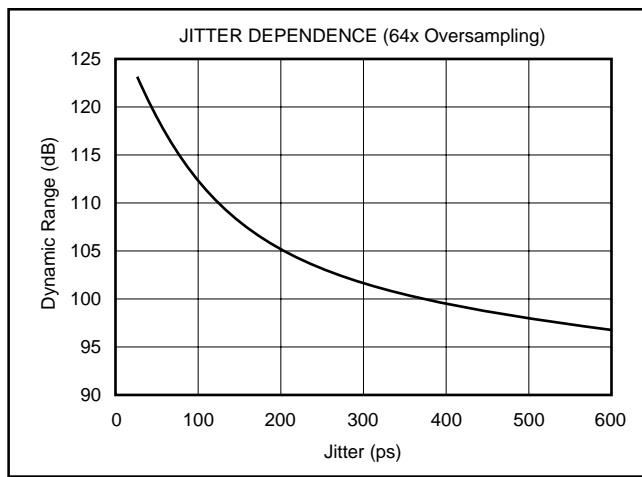

FIGURE 16. Jitter Sensitivity.

## KEY PERFORMANCE PARAMETERS AND MEASUREMENT

This section provides information on how to measure key dynamic performance parameters for the PCM1742. In all cases, an Audio Precision System Two Cascade or equivalent audio measurement system is utilized to perform the testing.

## TOTAL HARMONIC DISTORTION + NOISE

Total Harmonic Distortion + Noise (THD+N) is a significant figure of merit for audio DACs, since it takes into account both harmonic distortion and all noise sources within a specified measurement bandwidth. The true rms value of the distortion and noise is referred to as THD+N. Figure 17 shows the test setup for THD+N measurements.

For the PCM1742, THD+N is measured with a full-scale, 1kHz digital sine wave as the test stimulus at the input of the DAC. The digital generator is set to a 24-bit audio word length and a sampling frequency of 44.1kHz or 96kHz. The digital generator output is taken from the unbalanced S/PDIF connector of the measurement system. The S/PDIF data is transmitted via a coaxial cable to the digital audio receiver on the DEM-DAI1742 demo board. The receiver is then configured to output 24-bit data in either I<sup>2</sup>S or left-justified data format. The DAC audio interface format is programmed to match the receiver output format. The analog output is then taken from the DAC post filter and connected to the analog analyzer input of the measurement system. The analog input is band limited using filters resident in the analyzer. The resulting THD+N is measured by the analyzer and displayed by the measurement system.

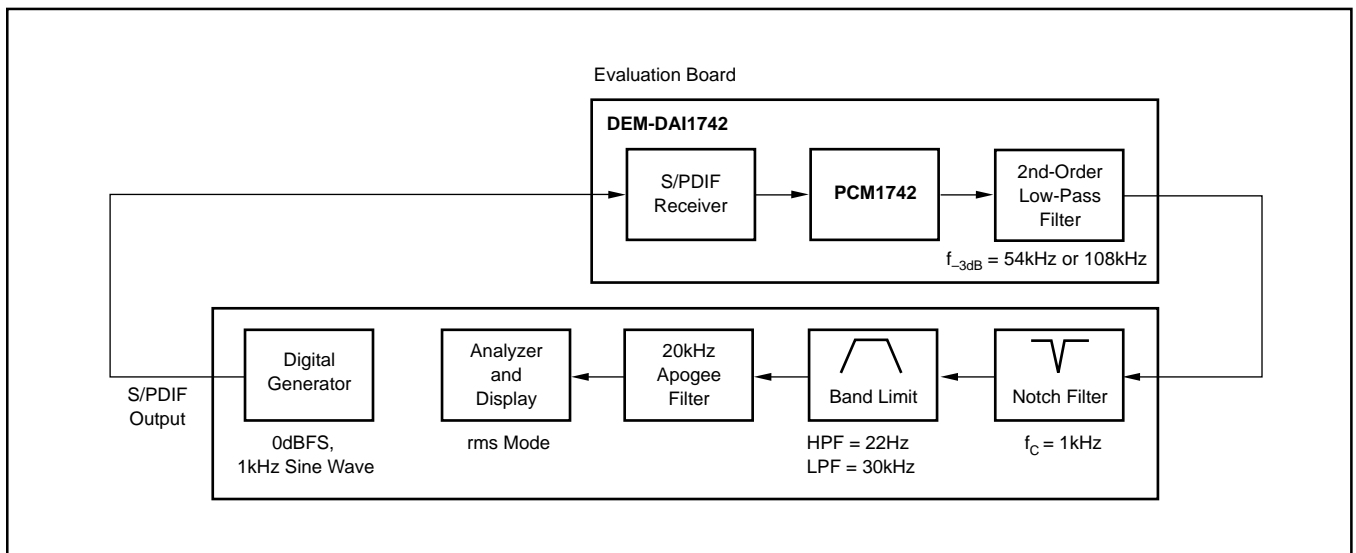

FIGURE 17. Test Setup for THD+N Measurements.

## DYNAMIC RANGE

Dynamic range is specified as A-Weighted, THD+N measured with a -60dBFS, 1kHz digital sine wave stimulus at the input of the DAC. This measurement is designed to give a good indicator of how the DAC will perform given a low-level input signal.

The measurement setup for the dynamic range measurement is shown in Figure 18, and is similar to the THD+N test setup discussed previously. The differences include the band limit filter selection, the additional A-Weighting filter, and the -60dBFS input level.

## IDLE CHANNEL SIGNAL-TO-NOISE RATIO

The SNR test provides a measure of the noise floor of the DAC. The input to the DAC is all “0”s data, and the DAC’s Infinite Zero Detect Mute function must be disabled (default condition at power up for the PCM1742). This ensures that the delta-sigma modulator output is connected to the output amplifier circuit so that idle tones (if present) can be observed and effect the SNR measurement. The dither function of the digital generator must also be disabled to ensure an all “0”s data stream at the input of the DAC. The measurement setup for SNR is identical to that used for dynamic range, with the exception of the input signal level (see the notes provided in Figure 18).

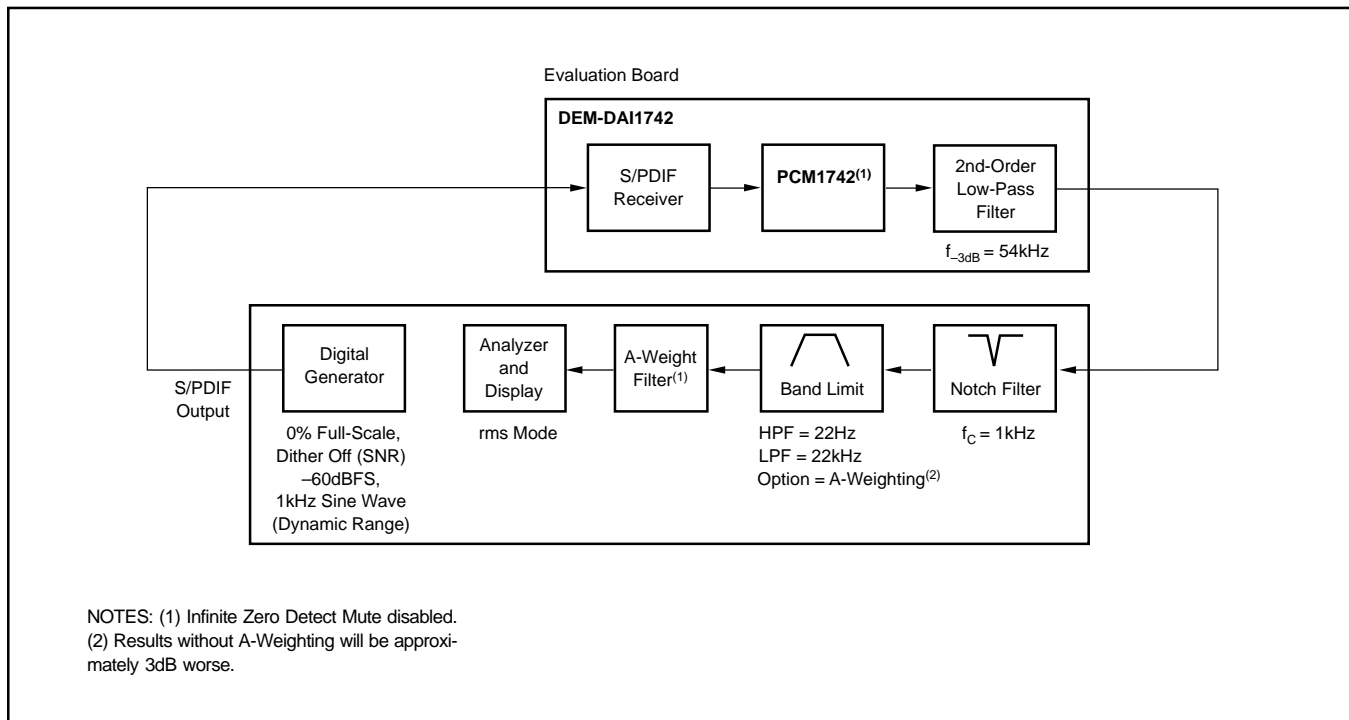

FIGURE 18. Test Setup for Dynamic Range and SNR Measurements.

**PACKAGING INFORMATION**

ORDERABLE DEVICE	STATUS(1)	PACKAGE TYPE	PACKAGE DRAWING	PINS	PACKAGE QTY
PCM1742E	ACTIVE	SSOP	DBQ	16	98
PCM1742E/2K	ACTIVE	SSOP	DBQ	16	2000
PCM1742KE	ACTIVE	SSOP	DBQ	16	98
PCM1742KE/2K	ACTIVE	SSOP	DBQ	16	2000

(1) The marketing status values are defined as follows:

**ACTIVE:** Product device recommended for new designs.

**LIFEBUY:** TI has announced that the device will be discontinued, and a lifetime-buy period is in effect.

**NRND:** Not recommended for new designs. Device is in production to support existing customers, but TI does not recommend using this part in a new design.

**PREVIEW:** Device has been announced but is not in production. Samples may or may not be available.

**OBSOLETE:** TI has discontinued the production of the device.

---

## IMPORTANT NOTICE

Texas Instruments Incorporated and its subsidiaries (TI) reserve the right to make corrections, modifications, enhancements, improvements, and other changes to its products and services at any time and to discontinue any product or service without notice. Customers should obtain the latest relevant information before placing orders and should verify that such information is current and complete. All products are sold subject to TI's terms and conditions of sale supplied at the time of order acknowledgment.

TI warrants performance of its hardware products to the specifications applicable at the time of sale in accordance with TI's standard warranty. Testing and other quality control techniques are used to the extent TI deems necessary to support this warranty. Except where mandated by government requirements, testing of all parameters of each product is not necessarily performed.

TI assumes no liability for applications assistance or customer product design. Customers are responsible for their products and applications using TI components. To minimize the risks associated with customer products and applications, customers should provide adequate design and operating safeguards.

TI does not warrant or represent that any license, either express or implied, is granted under any TI patent right, copyright, mask work right, or other TI intellectual property right relating to any combination, machine, or process in which TI products or services are used. Information published by TI regarding third-party products or services does not constitute a license from TI to use such products or services or a warranty or endorsement thereof. Use of such information may require a license from a third party under the patents or other intellectual property of the third party, or a license from TI under the patents or other intellectual property of TI.

Reproduction of information in TI data books or data sheets is permissible only if reproduction is without alteration and is accompanied by all associated warranties, conditions, limitations, and notices. Reproduction of this information with alteration is an unfair and deceptive business practice. TI is not responsible or liable for such altered documentation.

Resale of TI products or services with statements different from or beyond the parameters stated by TI for that product or service voids all express and any implied warranties for the associated TI product or service and is an unfair and deceptive business practice. TI is not responsible or liable for any such statements.

Following are URLs where you can obtain information on other Texas Instruments products and application solutions:

<b>Products</b>		<b>Applications</b>	
Amplifiers	<a href="http://amplifier.ti.com">amplifier.ti.com</a>	Audio	<a href="http://www.ti.com/audio">www.ti.com/audio</a>
Data Converters	<a href="http://dataconverter.ti.com">dataconverter.ti.com</a>	Automotive	<a href="http://www.ti.com/automotive">www.ti.com/automotive</a>
DSP	<a href="http://dsp.ti.com">dsp.ti.com</a>	Broadband	<a href="http://www.ti.com/broadband">www.ti.com/broadband</a>
Interface	<a href="http://interface.ti.com">interface.ti.com</a>	Digital Control	<a href="http://www.ti.com/digitalcontrol">www.ti.com/digitalcontrol</a>
Logic	<a href="http://logic.ti.com">logic.ti.com</a>	Military	<a href="http://www.ti.com/military">www.ti.com/military</a>
Power Mgmt	<a href="http://power.ti.com">power.ti.com</a>	Optical Networking	<a href="http://www.ti.com/opticalnetwork">www.ti.com/opticalnetwork</a>
Microcontrollers	<a href="http://microcontroller.ti.com">microcontroller.ti.com</a>	Security	<a href="http://www.ti.com/security">www.ti.com/security</a>
		Telephony	<a href="http://www.ti.com/telephony">www.ti.com/telephony</a>
		Video & Imaging	<a href="http://www.ti.com/video">www.ti.com/video</a>
		Wireless	<a href="http://www.ti.com/wireless">www.ti.com/wireless</a>

Mailing Address: Texas Instruments  
Post Office Box 655303 Dallas, Texas 75265

Copyright © 2003, Texas Instruments Incorporated